

AD-A031 183

ARMY AVIATION TEST BOARD FORT RUCKER ALA
MILITARY POTENTIAL TEST OF THE MODEL 135M BLADE TRACKER. (U)
OCT 66

F/G 1/3

UNCLASSIFIED

NL

[OF]

AD
A031183

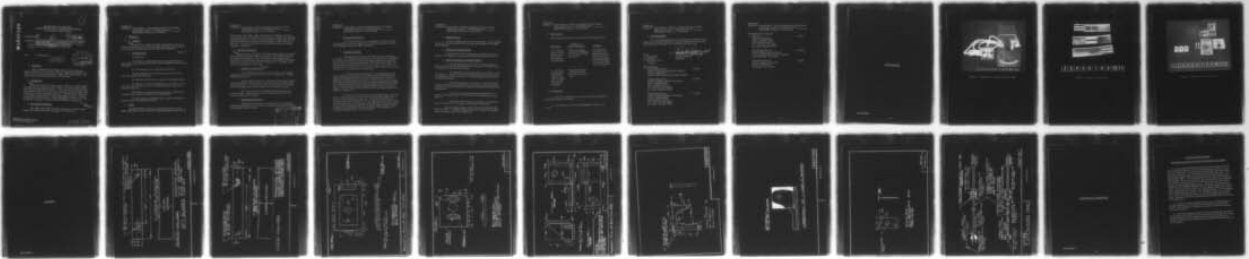

END

DATE
FILMED
H - 76

AD A 031183

DEPARTMENT OF THE ARMY
UNITED STATES ARMY AVIATION TEST BOARD
Fort Rucker, Alabama 36360

1
3-5

STEBG-TD

11
19 OCT 1966

9 6
SUBJECT: Letter Report, "Military Potential Test of the Model
135M Blade Tracker," RDT&E Project No. _____,
16 USATECOM Project No. 4-6-5014-01

TO: See Distribution

12 26p.

D D C
RECEIVED
OCT 26 1976
A

1. Reference.

Letter, SMOSM-EGG, Headquarters, US Army Aviation Materiel Command, 6 June 1966, subject: "Request for Military Potential Test," with 1st Indorsement, AMSTE-BG, Headquarters, US Army Test and Evaluation Command, 12 July 1966.

2. Background.

There has existed for some years a need for a reliable system for tracking Army helicopter rotor blades on the ground and in flight under day and night VFR conditions. The electronic rotor-blade tracking equipment in use today requires an extensive amount of depot maintenance and is limited to ground tracking. In addition, the equipment is unreliable during inclement weather and night operation. In an attempt to solve this problem, a Model 135M Blade Tracker was sent to the US Army Aviation Test Board (USAAVNTBD) for testing

3. Description of Materiel.

The Model 135M Blade Tracker consists of a portable power supply and a hand-held strobe light (figure 1, inclosure 1).

PG. 2

STEBG-TD

SUBJECT: Letter Report, "Military Potential Test of the Model 135M Blade Tracker," RDT&E Project No. _____, USATECOM Project No. 4-6-5014-01

4. Objectives.

a. Purpose.

To determine whether the Model 135M Blade Tracker has military potential for use in tracking Army helicopter rotor blades on the ground and in flight under day and night VFR conditions.

b. Test Objectives.

To determine:

- (1) Whether a significant reduction in weight and dimensions exists when compared with those of the AN/USM-188 Blade Tracking System.
- (2) The adequacy of the operational procedures.
- (3) The length and type wiring required to use the test item with the CH-47A Helicopter.
- (4) Optimum size and color scheme for tracking tip tabs.
- (5) Whether a special sighting device is necessary to provide read-out from tabs and, if so, to determine power, size, and bracketry required.
- (6) Whether maintenance of the test item is reduced significantly when compared with that of the AN/USM-188.
- (7) Any changes or additional items required to adapt the blade tracker to the CH-47A Helicopter.

5. Scope.

The USAAVNTBD conducted a military potential test of the Model 135M Blade Tracker using the CH-47A during the period 25 July

STEBG-TD

SUBJECT: Letter Report, "Military Potential Test of the Model 135M Blade Tracker," RDT&E Project No. _____, USATECOM Project No. 4-6-5014-01

1966 through 9 September 1966 at Fort Rucker, Alabama, and Fort Benning, Georgia. The military potential of the test item for tracking Army helicopter rotor blades on the ground and in flight under day and night VFR conditions was determined through use of the test item for 26 hours. Use of the test item was restricted to temperate climate, fixed-base conditions.

6. Summary of Results.

The test item, as adapted, operated satisfactorily for tracking CH-47A Helicopter rotor blades on the ground and in flight under day and night VFR conditions. The system had a concentrated parallel light beam of such intensity that tracking was accomplished during daylight at any position other than directly into the sun. At night, there was an over-abundance of light.

a. Weights and Dimensions.

The weight and dimensions of the test item were reduced significantly when compared with those of the AN/USM-188. Weights and dimensions were:

(1) The Model 135M power supply and strobe light weighed 16 pounds and the connecting cables required weighed 12 pounds, for a total of 28 pounds. The dimensions of the power supply and carrying case for the flash tube were 6.5 inches x 6.5 inches x 15 inches.

(2) The weight of the AN/USM-188 with the transit case was 150 pounds. Physical dimensions of this transit case were 21 inches x 24 inches x 26 inches.

b. Operational Procedures.

Operational procedures were not furnished. Procedures established during the test are shown in inclosure 3, and were suitable for operation of the test item.

| | |
|---------------------------------|---------------|
| RECEIVED | DATE |
| BY | DATE |
| DISTRIBUTION/AVAILABILITY CODES | UNCLASSIFIED |
| JUSTIFICATION | WHILE SERVICE |
| INITIALS | DATE |

STEBG-TD

SUBJECT: Letter Report, "Military Potential Test of the Model 135M Blade Tracker," RDT&E Project No. _____, USATECOM Project No. 4-6-5014-01

c. Wiring Requirements.

The wiring requirements to adapt the test item to the CH-47A Helicopter were determined to be two 100-foot extension cables, Type SJAWG18 (drawing No. 5, inclosure 2).

d. Tracking Tip Tabs.

The optimum tracking tip-tab target size was 7 inches x 1.5 inches. (See tracking tab drawing No. 1, inclosure 2.) The blade-tip targets were similar in construction and consisted of six targets per set, three for the forward and three for the aft rotor blades. The most suitable color scheme for the tabs was yellow, red, and green, using strips of reflective tape on one set for night operation and jeweled reflectors on the other set for day operation.

(1) The tape color scheme was so arranged that the red target, which was mounted on the red blade, had one horizontal 1/4-inch stripe through the center; the green target had three 1/4-inch stripes with 1/4-inch spaces located on one end; and the yellow target had three 1/4-inch stripes with 1/4-inch spaces located on the opposite end. When the operator was viewing the target tip tabs with the strobe light, an ideal intrack condition was indicated by a three-one-three pattern, with the red bar in line with the center green and yellow bars (figure 5, inclosure 1).

(2) The jeweled reflectors were arranged yellow, red, and green. The jeweled color scheme was arranged on the target tabs in strips 0.5 inch wide and 2 inches long. The yellow reflector was mounted on the left end of the tab, the red reflector in the center, and the green reflector on the right end of the tab, so that when the operator was viewing the target tip tabs with the strobe light, an ideal intrack condition was indicated by a pattern of yellow, red, and green in a straight-line pattern (figure 5, inclosure 1).

STEBG-TD

SUBJECT: Letter Report, "Military Potential Test of the Model
135M Blade Tracker," RDT&E Project No. _____,
USATECOM Project No. 4-6-5014-01

e. Sighting Device.

A special sighting device was not required. Visual sighting across the top of the hand-held strobe light was adequate for reading the tip targets.

f. Maintenance Requirements.

During the 26 hours of operation, no maintenance was required. No maintenance manuals were furnished with the test item.

g. Required Changes and Additional Items.

(1) The following items which were needed to adapt the blade tracker to the CH-47A Helicopter, but were not provided, had to be designed and manufactured locally:

(a) Tracking tip-tab targets (figure 2, inclosure 1 and drawing No. 1, inclosure 2) for the forward and aft rotor blades (each set containing six tabs; one set for use during daylight and one set for use during darkness).

(b) Bracketry (figure 3, inclosure 1 and drawing Nos. 2 and 3, inclosure 2) to mount the magnetic pick-up (one type for aircraft prior to S/N 64-13132 and one type for aircraft S/N 64-13132 and subsequent).

(c) Necessary wiring and connectors (figure 4, inclosure 1 and drawing No. 5, inclosure 2) for providing power to the test item.

(d) Striker plates (figure 3, inclosure 1 and drawing No. 4, inclosure 2) for mounting on swashplate rotating star.

(2) The magnetic phase detector (P/N 1332-300-02, FSN 1615-789-4975), a standard supply item, was required for signalling electrical inputs to the power supply unit.

STEBG-TD

SUBJECT: Letter Report, "Military Potential Test of the Model 135M Blade Tracker," RDT&E Project No. _____, USATECOM Project No. 4-6-5014-01

7. Deficiencies.

The following deficiencies were discovered during this test:

| <u>Deficiency</u> | <u>Suggested Corrective Action</u> | <u>Remarks</u> |
|--|--|---|
| a. No operational or maintenance procedures were furnished with the test item. | Proper procedures should be established for use with all Army helicopters. | The operational procedures established during the test were suitable for tracking CH-47A Helicopter rotor blades under the test conditions. |
| b. An installation kit was not provided with the test item for adapting it to helicopter blade tracking. | Provide suitable installation kits for each type Army helicopter. | |

8. Conclusions.

a. The Model 135M Blade Tracker has military potential for tracking helicopter rotor blades.

b. The deficiencies outlined in paragraph 7 should be corrected.

STEBG-TD

SUBJECT: Letter Report, "Military Potential Test of the Model
135M Blade Tracker," RDT&E Project No. _____,
USATECOM Project No. 4-6-5014-01

9. Recommendation.

It is recommended that when the deficiencies outlined in paragraph 7 are corrected, additional testing be conducted to determine maintainability, durability, and suitability of the test item.

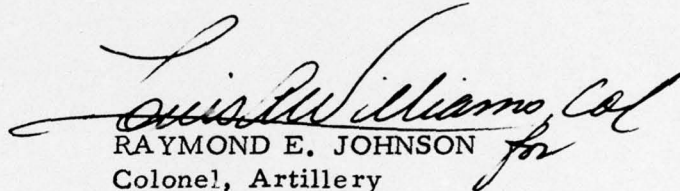
RAYMOND E. JOHNSON
Colonel, Artillery
President

3 Incl

1. Photographs
2. Drawings
3. Operational Procedures

DISTRIBUTION:

Commanding General 2 copies
US Army Test and Evaluation Command
ATTN: AMSTE-BG
Aberdeen Proving Ground, Maryland 21005

Commanding General 5 copies
US Army Aviation Materiel Command
ATTN: SMOSM-EAC
12th and Spruce Streets
P. O. Box 209, Main Office
St. Louis, Missouri 63166

Commanding General 3 copies
US Army Aviation Materiel Command
ATTN: AMSAV-EGGG
12th and Spruce Streets
P. O. Box 209, Main Office
St. Louis, Missouri 63166

STEBG-TD

SUBJECT: Letter Report, "Military Potential Test of the Model
135M Blade Tracker," RDT&E Project No. _____,
USATECOM Project No. 4-6-5014-01

DISTRIBUTION (continued):

Director 3 copies
Chinook Field Office
ATTN: AMCPM-CHFO
12th and Spruce Streets
P.O. Box 209, Main Office
St. Louis, Missouri 63166

Commanding General 2 copies
US Army Electronics Command
ATTN: AMSEL-RD-GTI (Mr. Crawley)
Fort Monmouth, New Jersey

Commanding General 5 copies
US Army Materiel Command
ATTN: AMCPM-CH
Washington, D.C. 20315

PHOTOGRAPHS

INCLOSURE 1

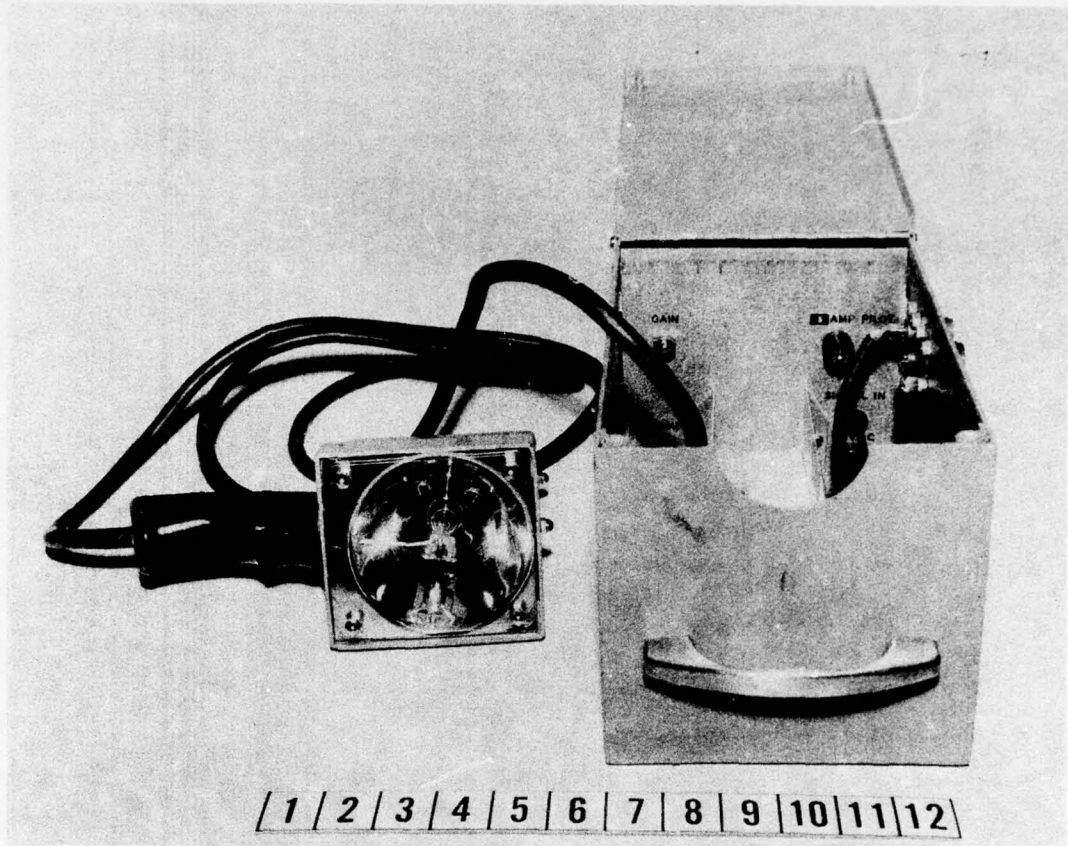

Figure 1. Portable power supply and strobe light.

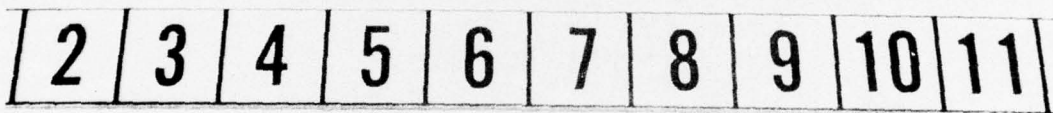
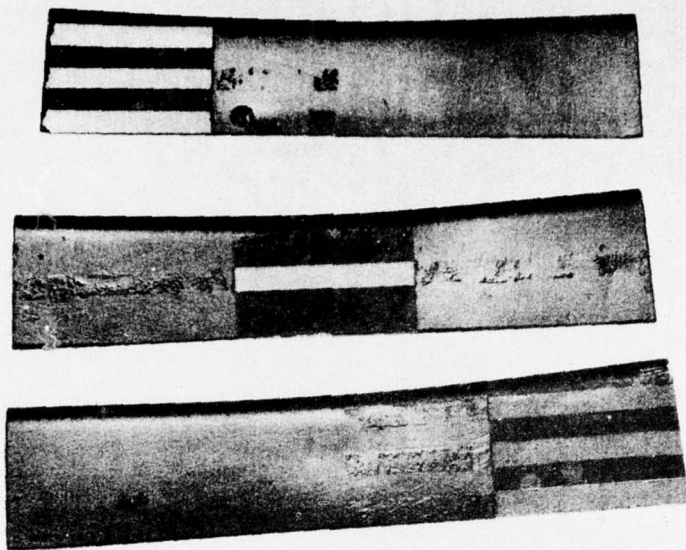

Figure 2. Tracking tip-tab targets.

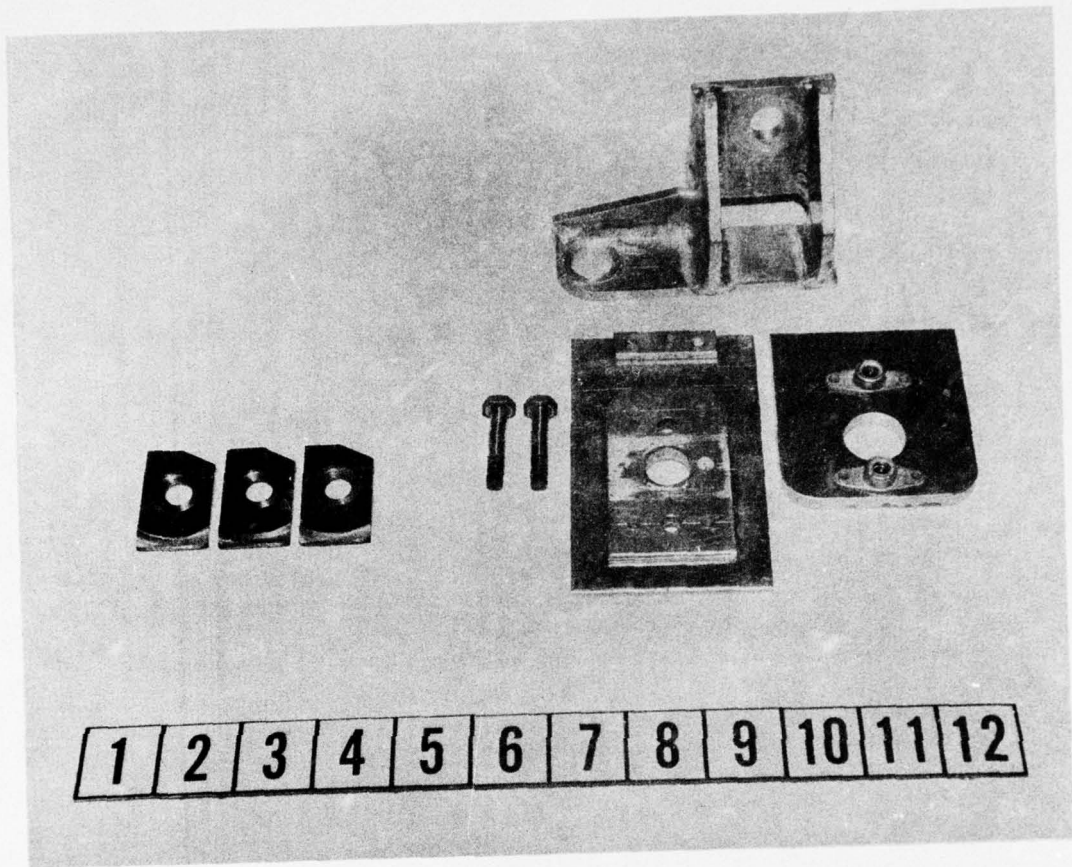
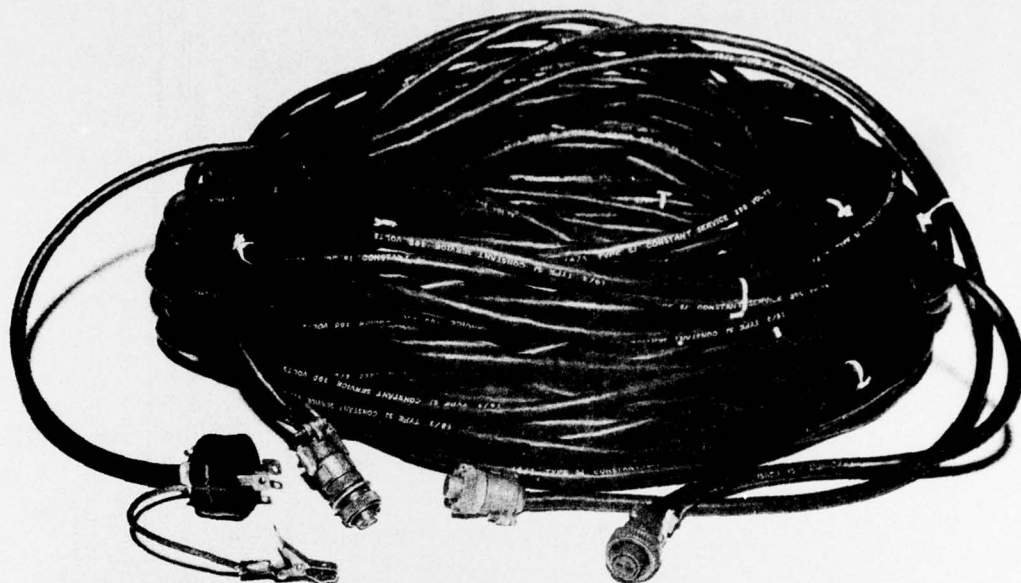

Figure 3. Striker plates and bracketry.



1 | 2 | 3 | 4 | 5 | 6 | 7 | 8 | 9 | 10 | 11 | 12

Figure 4. Wiring and connector plugs.

IDEAL TIP TAB TARGET PATTERN

Tape pattern

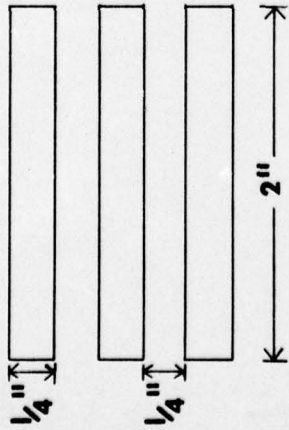

yellow



green

Jewel pattern

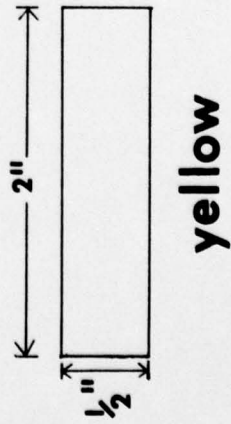

yellow

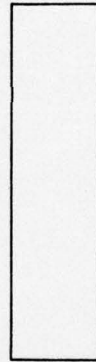

red

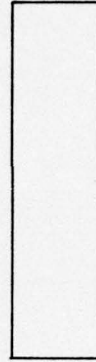

green

Figure 5.

DRAWINGS

INCLOSURE 2

3/16" (.187) ELONGATED HOLE V/4 (25) DRILL THIS END ONLY. C" SINK TO MATCH BLADE TIP SCREW

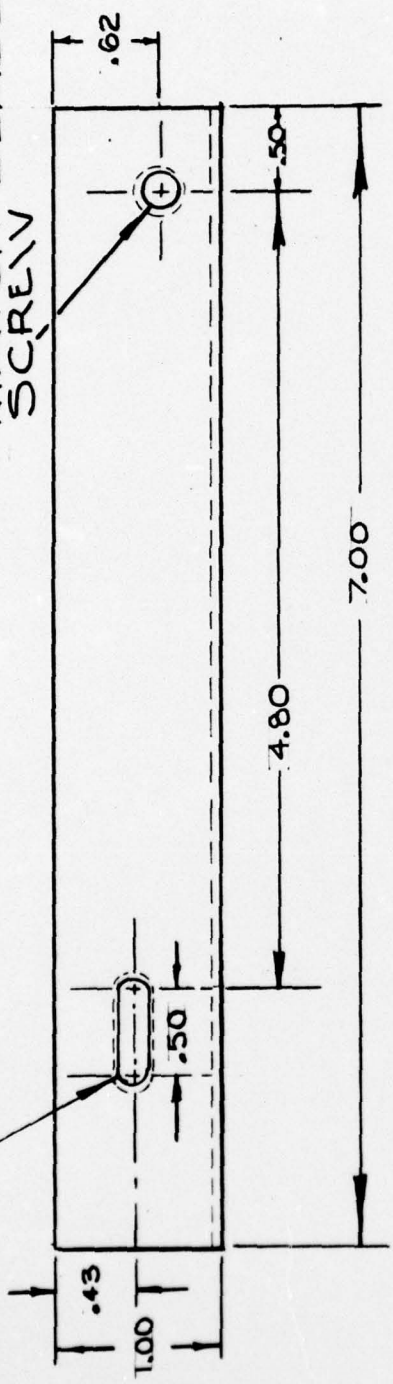

CONTOUR TO MATCH LOWER SIDE OF BLADE

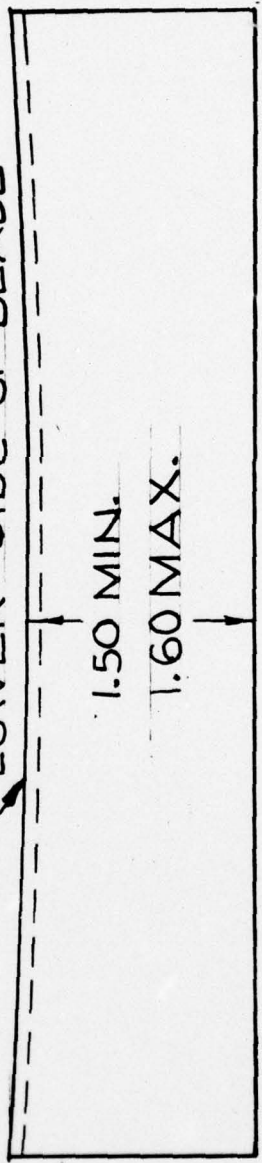

TRACKING ANGLES
CH-47 MAT'L: 2024-T3
ALUM: .063 THK
3 PER SET

SCALE: FULL SIZE

AFT BLADES

SHEET 1 OF 2

DRAWING NO. 1

3/16 INCH (.187)
FLONGATED HOLE
"C" SINK AROUND

1/4 INCH (.25) DRILL
THIS END ONLY.
"C" SINK TO MATCH
BLADE TIP SCREW

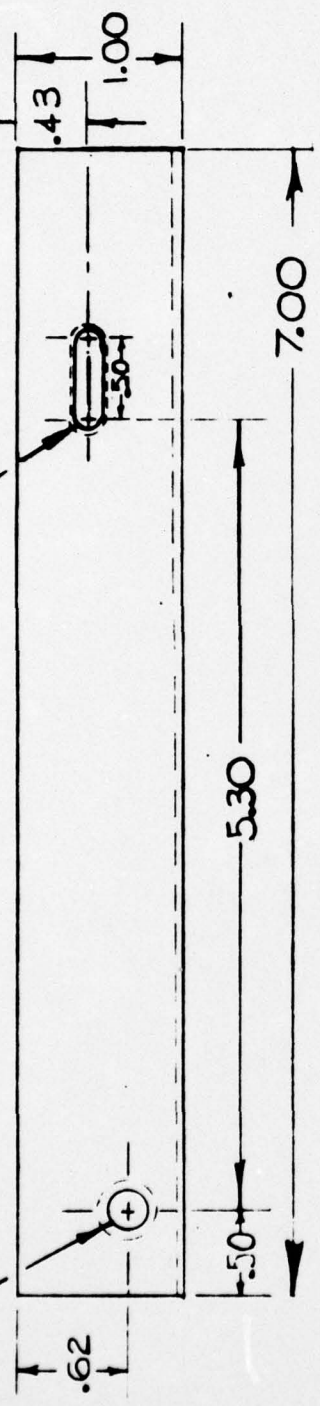

CONTOUR TO MATCH
SIDE OF BLADE

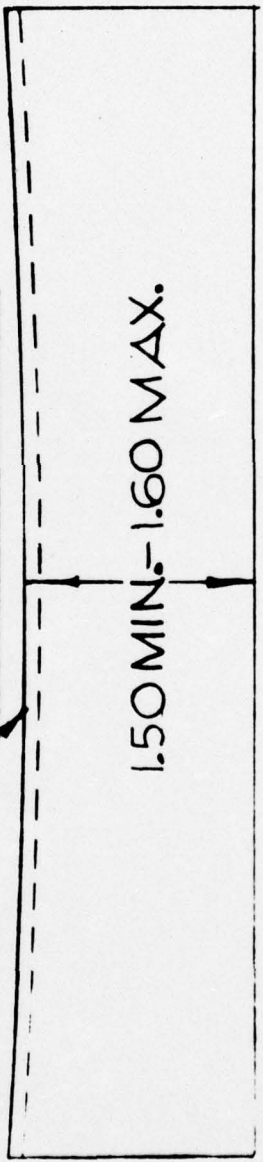

TRACKING ANGLES
CH-47 FIVD BLADES
MATL: 2024 T3 ALUM.
.063 THK. 3 PER SET

SCALE: FULL SIZE

SHEET 2 OF 2

DRAWING NO. 1

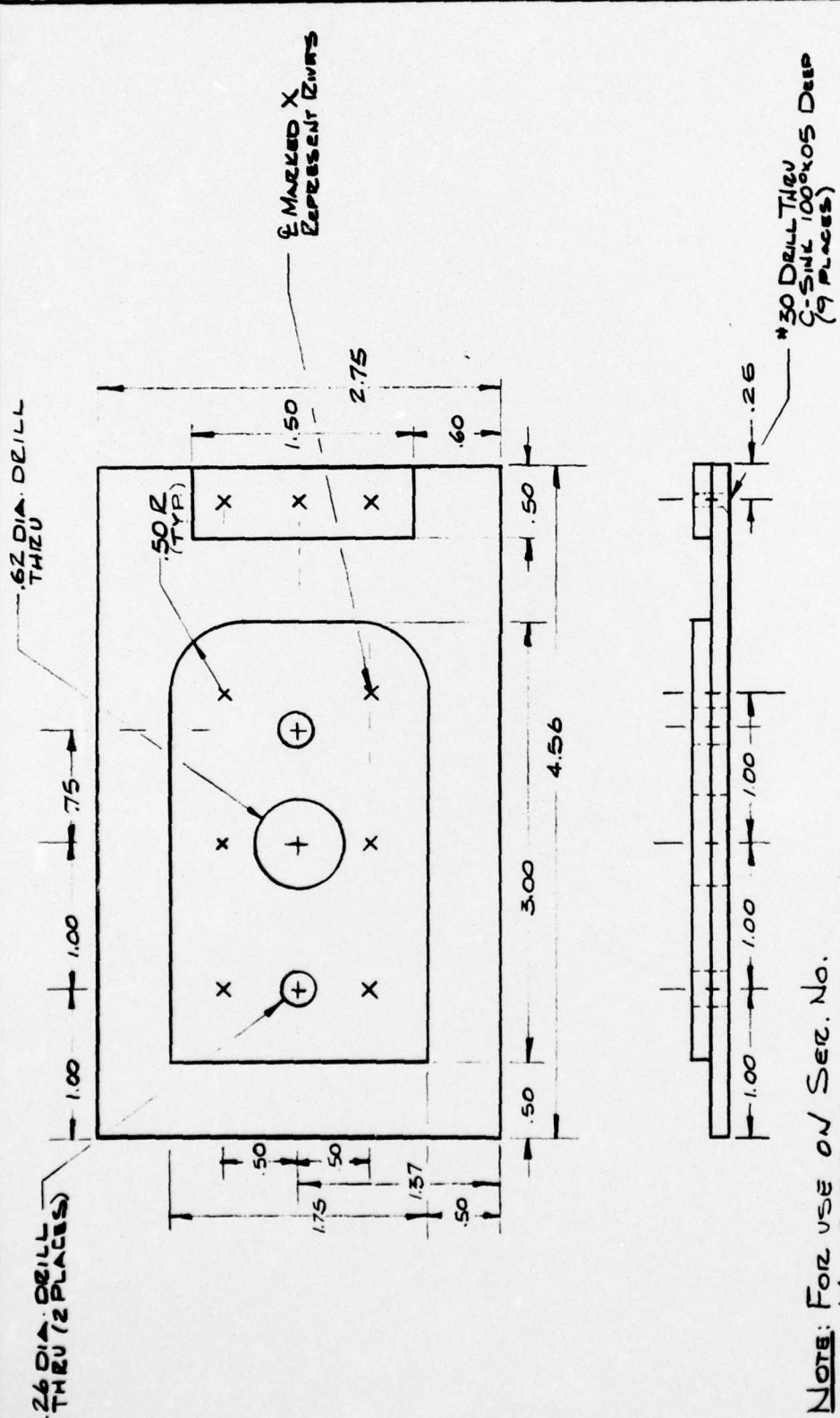

NOTE: FOR USE ON SER. NO. 64-13132 AND SUBSEQUENT

FOR BRACKET ASSEMBLY
 MAT'L - 2024-T3 ALUM .25 STK
 RIVETS - MS 20426AD4 9EA. 1260'S
 SCALB - FULL SIZE

SHT 1 OF 2

MAGNETIC PICK-UP BKT. (CH-47A)

DRAWING NO. 2

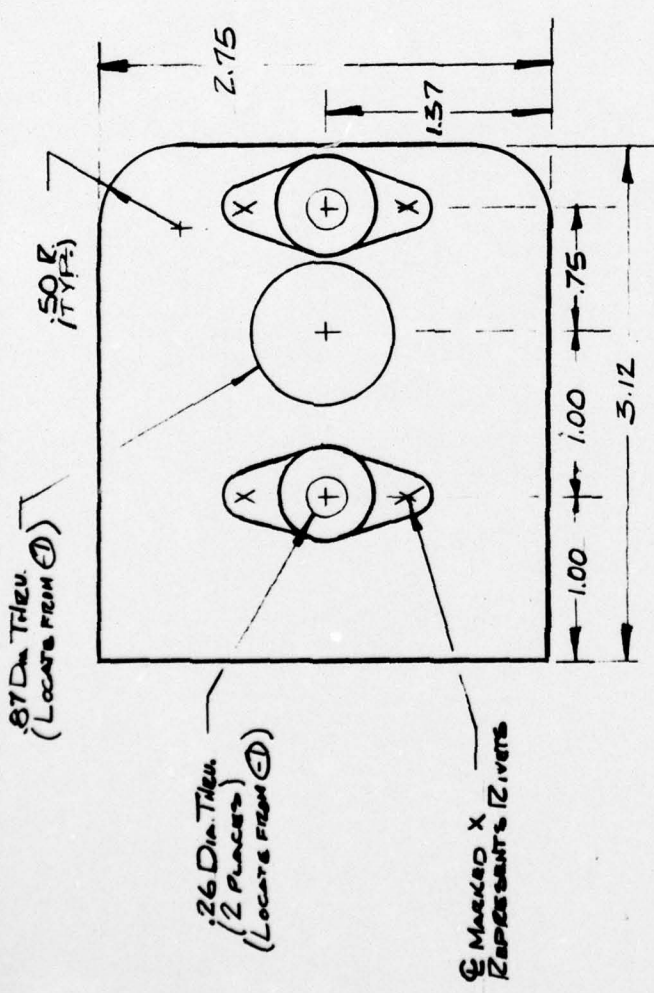

NOTE: ATTACH -1 TO-2
WITH AN 174 BOLTS 2 EA.



② FOR BRACKET ASSY
MATERIAL - 2024-T3 ALUM .25 THK
NUT PLATE P/N NAS 686A4
RIVET P/N - MS20470AD TO MATCH PLATE
SCALE - FULL SIZE

SMT 20F2

DRAWING NO. 2

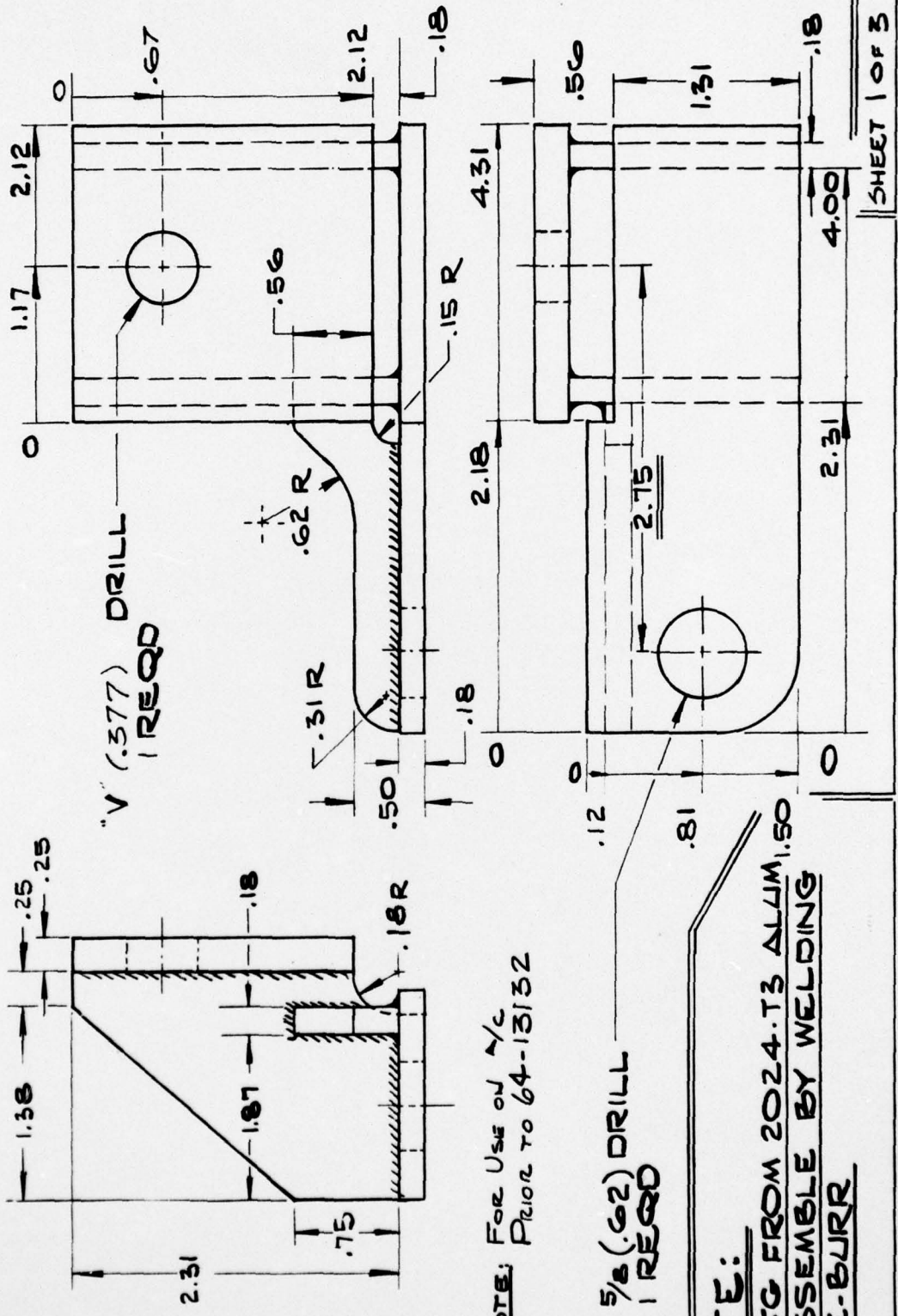

NOTE: For Use on 1/2
Prior to 64-13132

5/8 (.62) DRILL
1 REQD

NOTE:

- 1- MEG FROM 2024-T3 ALUM 1.50
- 2- ASSEMBLE BY WELDING
- 3- DE-BURR

SHEET 1 OF 3

MAGNETIC PICK-UP BKT (CH-47A) - 1

DRAWING NO. 3

ATTACHING LINES TO -1,
OUTSIDE OF THESE MAY BE
CUT OFF AFTER ATTACHING.

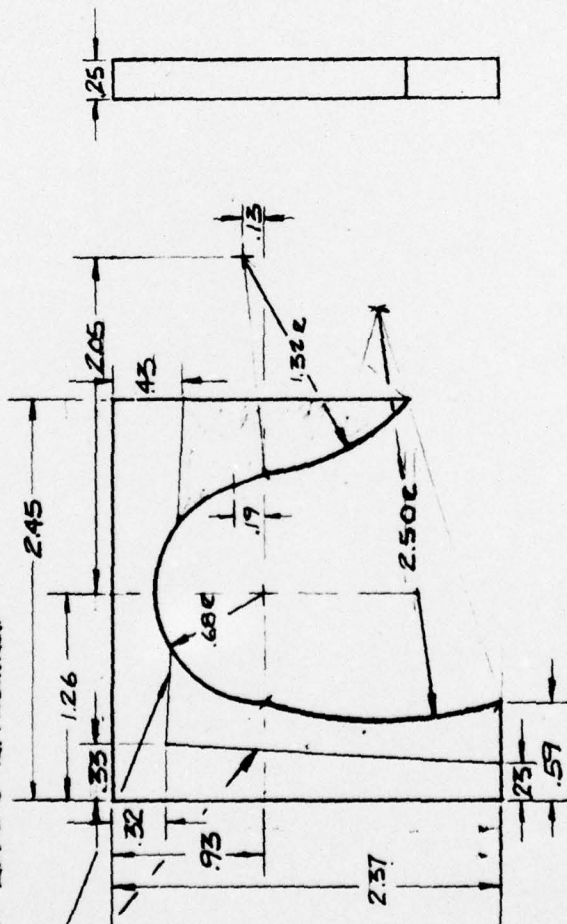

LOCK PLATE -2

MATL - 1/4" STL. ALUM.

SCALE: FULL SIZE

SHEET 2 OF 3

DRAWING NO. 3

ATTACH -1
TO -2 BY WELDING

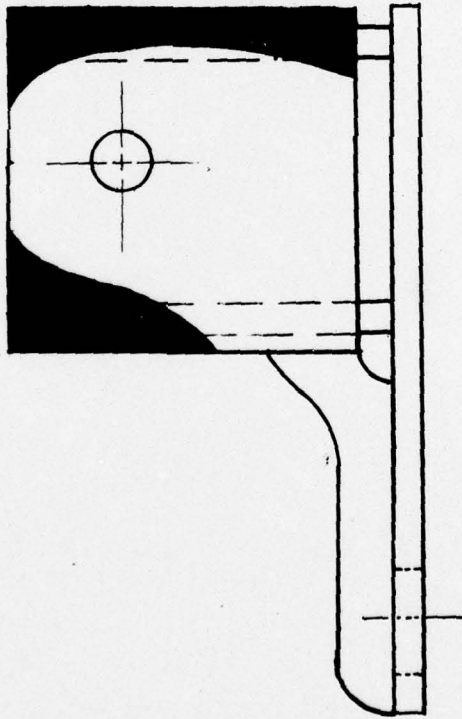

ASSEMBLY OF -1 AND -2 SHOWN

SHEET 3 OF 3

DRAWING NO. 3

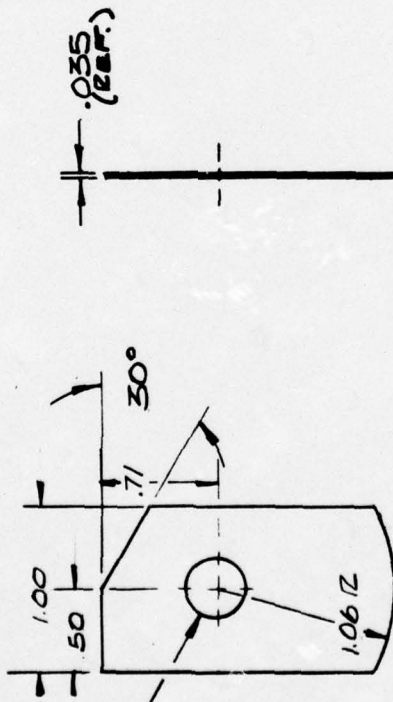

V(577) Drill Thru
1 REQ'D

STRIKER RATE
MATERIAL 4130 COMM'L STEEL .055 THK
SCANS - FULL SIZE
3 REQ'D PER SET.

SHT 1 OF 1

DRAWING NO. 4

CAUTION: POLARITY MUST BE OBSERVED

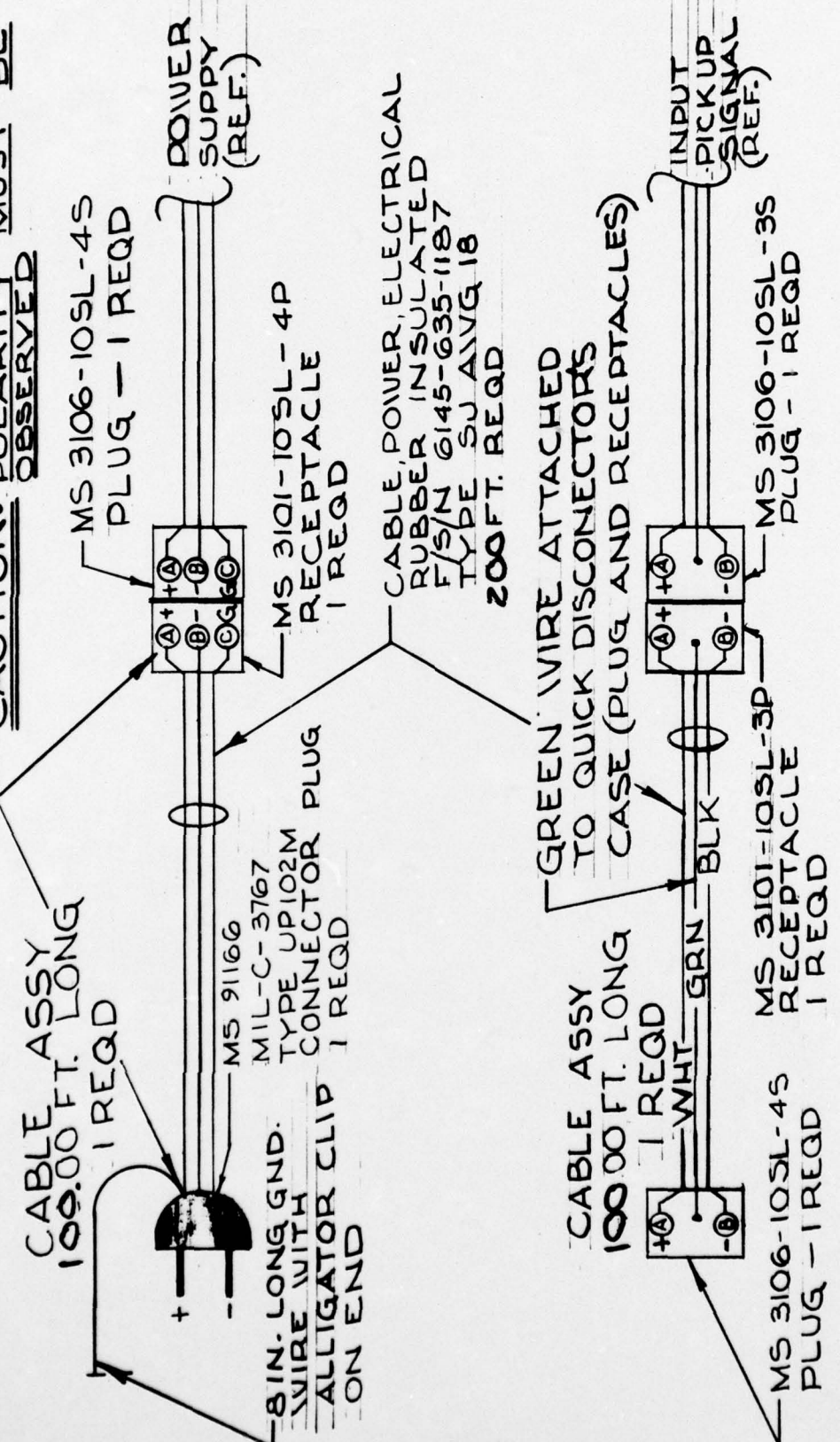

SHEET 1 OF 1

DRAWING NO. 5

WIRE EXTENSION SYC.

OPERATIONAL PROCEDURES

INCLOSURE 3

Model 135M Blade Tracker

Operational Procedures for CH-47A Helicopter Rotor Blades

1. A concentrated parallel light beam from the hand-held strobe light is directed manually toward a predetermined periphery area of the rotor-blade disc so as to strike the rotor-blade tracking tip tabs, which are mounted on the rotor-blade tips by means of screws. The strobe light trigger switch is then depressed to allow strobing of the blade-tip tab plates. The pulse signal for strobe effect is provided by the magnetic pick-up unit mounted on the forward stationary swashplate which sends a pulse each time one of the three pick-up striker plates passes over the magnetic pick-up unit. The three pick-up plates are mounted on the rotating swashplate and are equally spaced 120 degrees apart. The forward rotor blades can be tracked in flight from: (a) the cabin through the open top half of the right-hand door, or (b) through the forward left-hand cabin window. The aft rotor blades can be tracked from: (a) the aft left-hand window, or (b) the aft right-hand window. Blade tracking can also be accomplished from outside when the aircraft is on the ground.

2. Any out-of-track condition will show up as a displacement of the ideal pattern of 1/4-inch stripes and 1/4-inch spaces between stripes. It is possible to estimate accurately the amount of displacement up to 3/4 inch.

3. The blade-tracking tip tabs should be removed after the tracking operation is completed to prevent decreased blade efficiency during normal operations. The magnetic pick-up and striker plates may remain installed without interfering with operational characteristics of the helicopter.