

AD-A031 254

ARMY ENGINEER WATERWAYS EXPERIMENT STATION VICKSBURG MISS F/G 9/2
CORPS-WIDE CONFERENCE ON COMPUTER-AIDED DESIGN IN STRUCTURAL EN--ETC(U)
AUG 76 R L HALL, B DAINS, D BRYANT

UNCLASSIFIED

NL

1 OF 1
AD
A031254



END
DATE
FILMED
11-76

AD A 031 254

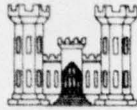

CORPS-WIDE CONFERENCE ON

COMPUTER
AIDED
DESIGN IN
STRUCTURAL
ENGINEERING

01

22-26 September 1975

VOLUME XII INTERACTIVE GRAPHICS, SEARCH and CORPS SYSTEMS

Edited by N. RADHAKRISHNAN

Approved for public release; distribution unlimited.

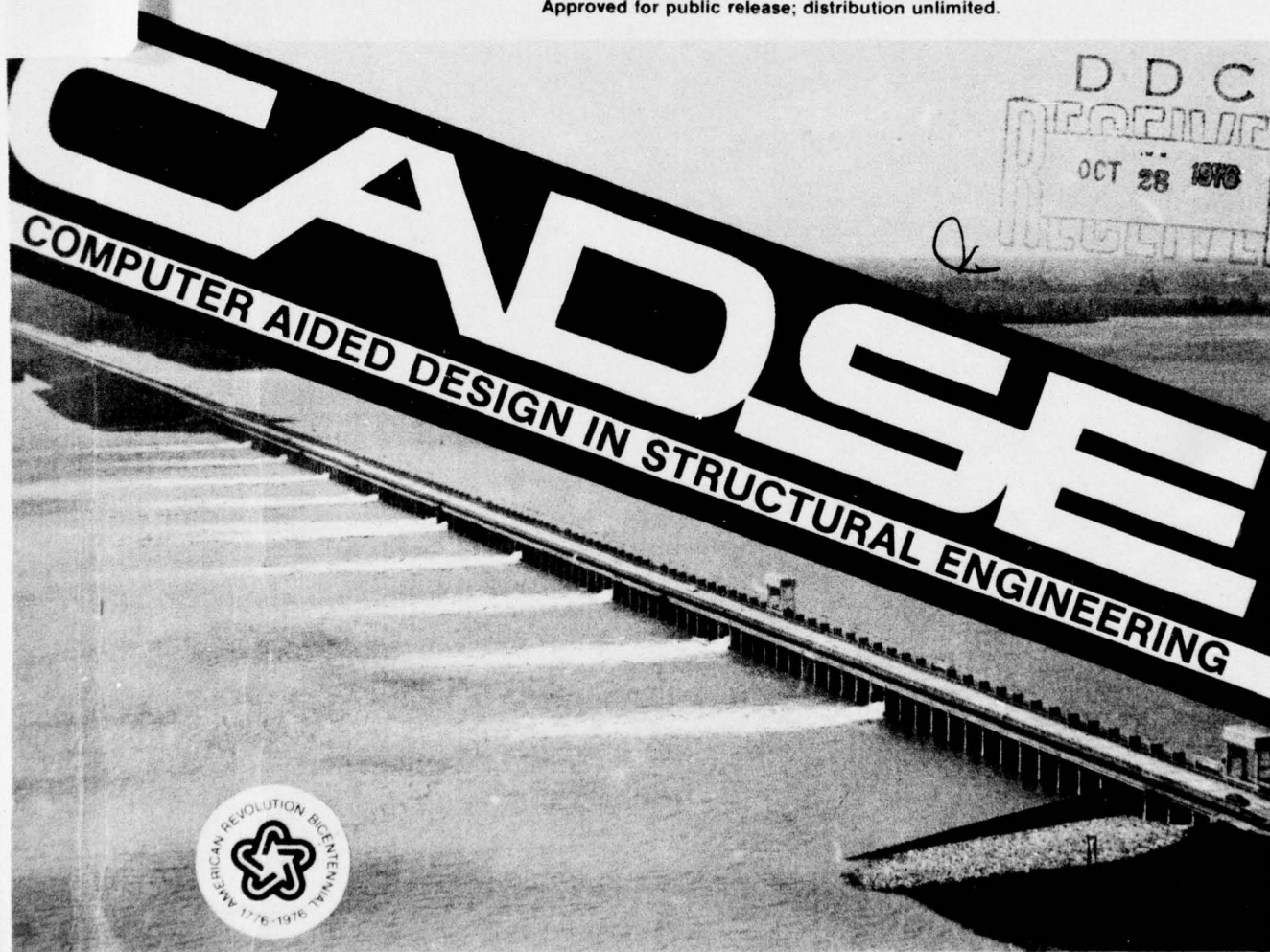

August 1976

Prepared for Office, Chief of Engineers, U. S. Army
Washington, D. C. 20314

by Automatic Data Processing Center
U. S. Army Engineer Waterways Experiment Station
P. O. Box 631, Vicksburg, Mississippi 39180

Unclassified

SECURITY CLASSIFICATION OF THIS PAGE (When Data Entered)

REPORT DOCUMENTATION PAGE		READ INSTRUCTIONS BEFORE COMPLETING FORM
1. REPORT NUMBER Unnumbered	2. GOVT ACCESSION NO.	3. RECIPIENT'S CATALOG NUMBER
6. TITLE (and Subtitle) CORPS-WIDE CONFERENCE ON COMPUTER-AIDED DESIGN IN STRUCTURAL ENGINEERING. VOLUME XII. INTER- ACTIVE GRAPHICS, SEARCH AND CORPS SYSTEMS.	5. TYPE OF REPORT & PERIOD COVERED Volume 12 of 12 volumes	
	6. PERFORMING ORG. REPORT NUMBER	
7. AUTHOR(s) Robert L. Hall, Bruce Dains, Dale Bryant, Janet H. Spoonamore H. Wayne Jones, edited by N. Radhakrishnan	8. CONTRACT OR GRANT NUMBER(s)	
9. PERFORMING ORGANIZATION NAME AND ADDRESS U. S. Army Engineer Waterways Experiment Station Automatic Data Processing Center P. O. Box 631, Vicksburg, MS. 39180	10. PROGRAM ELEMENT, PROJECT, TASK AREA & WORK UNIT NUMBERS 12/80 p.	
11. CONTROLLING OFFICE NAME AND ADDRESS Office, Chief of Engineers, U. S. Army Washington, DC 20314	12. REPORT DATE Aug 76	
14. MONITORING AGENCY NAME & ADDRESS (if different from Controlling Office)	13. NUMBER OF PAGES 76	
	15. SECURITY CLASS. (of this report) Unclassified	
15a. DECLASSIFICATION/DOWNGRADING SCHEDULE		
16. DISTRIBUTION STATEMENT (of this Report) Approved for public release; distribution unlimited.		
17. DISTRIBUTION STATEMENT (of the abstract entered in Block 20, if different from Report)		
18. SUPPLEMENTARY NOTES <i>see abstract card</i> Presented at Corps-wide Conference on Computer-Aided Design in Structural Engineering, 22-26 September 1975, New Orleans, LA.		
19. KEY WORDS (Continue on reverse side if necessary and identify by block number) Computer-aided design--Congresses Computer graphics Design--Congresses CORPS (computer program collection) Structural engineering--Congresses SEARCH (computer program)		
20. ABSTRACT (Continue on reverse side if necessary and identify by block number) INTERACTIVE COMPUTER GRAPHICS can reduce the time and cost of any design process by at least one-third. To realize this great reduction, interactive computer graphics programs will have to be developed at every design level. This development was not even feasible 10 yr ago, since at that time a single computer graphics device would have cost \$200,000. Today, low-cost (\$5,000- \$15,000) graphics terminals are available, making interactive computer (Continued)		

038 100 ✓

mt

Unclassified

SECURITY CLASSIFICATION OF THIS PAGE(When Data Entered)

20. ABSTRACT (Continued).

graphics practical in the Corps of Engineers. SEARCH is an automated architectural criteria maintenance and design evaluation system. SEARCH is used in two phases of Corps design work. First, performance type architectural design criteria are checked for consistency, documented as to information location, and stored for later use. Second, design layouts produced by Architect/Engineers are put into SEARCH. The result is a full, unbiased evaluation based on the previously checked and stored criteria. The system is currently being used by the Office of the Chief of Engineers for evaluating and developing the new Corps Design Guides. CORPS, the Conversationally Oriented Real-Time Program Generating System, provides computational support for engineering planners, designers, and managers who require a responsive computer resource, but do not choose to be computer programmers. The user and the computer can interact conversationally to allow any engineer to use all of the programs in the Corps library with a minimum of effort. This paper gives (a) guidelines for programs incorporated in CORPS, (b) the run sequence for using CORPS, (c) an example problem showing the use of one program, (d) a list of the programs presently in CORPS at WES, (e) a list of the programs being added to the CORPS library, and (f) excerpts from an article by Robert L. Renner outlining an early conception of CORPS.

Unclassified

SECURITY CLASSIFICATION OF THIS PAGE(When Data Entered)

THE CONTENTS OF THIS REPORT ARE NOT TO BE
USED FOR ADVERTISING, PUBLICATION, OR
PROMOTIONAL PURPOSES. CITATION OF TRADE
NAMES DOES NOT CONSTITUTE AN OFFICIAL EN-
DORSEMENT OR APPROVAL OF THE USE OF SUCH
COMMERCIAL PRODUCTS.

ACCESSION TO	
REIS	White Section <input checked="" type="checkbox"/>
DDC	Env Section <input type="checkbox"/>
GRANNOUNCES	<input type="checkbox"/>
JUSTIFICATION.....	
BY.....	
DISTRIBUTION/AVAILABILITY CODES	
Dist.	AVAIL. END. OR SPECIAL
A	

PREFACE

In December 1974, the Automatic Data Processing (ADP) Center, U. S. Army Engineer Waterways Experiment Station (WES), submitted a proposal to conduct a Corps-wide Conference on Computer-Aided Design in Structural Engineering (CADSE) to the Office, Chief of Engineers (OCE). OCE approved the proposal and efforts were started in February 1975 to conduct this Conference. The Conference was conducted in New Orleans, Louisiana, 22-26 September 1975 and was attended by 175 engineers from 48 Corps field offices, OCE, Construction Engineering Research Laboratory (CERL), and WES.

This volume contains papers from Specialty Session H, Learning and Demonstrations: Interactive Graphics, SEARCH and CORPS Systems. Mr. Robert L. Hall, Civil Engineer, Computer Analysis Branch, WESKA, was session chairman and presented a paper. Other papers were presented by Mr. Bruce Dains and Mr. Dale Bryant (Mrs. Janet H. Spoonamore was a co-author), Research Architects, Architecture Branch, CERL-FHA, USA Construction Engineering Research Laboratory; and Mr. H. Wayne Jones, Civil Engineer, Computer Analysis Branch, WESKA.

The Conference was successful due to the efforts of a multitude of people. The roles they played were different but they were all directed toward making a concept on "instant dissemination" work. The Organizing Committee for the Conference consisted of:

COL G. H. Hilt, WES
Mr. F. R. Brown, WES
Mr. D. L. Neumann, WES
Mr. J. B. Cheek, Jr., WES
Dr. N. Radhakrishnan, WES--Conference Coordinator
Mr. W. A. Price, WES
Mr. G. S. Hyde, WES
Mr. D. R. Dressler, LMVD
Mr. W. B. Dodd, LMNDE
Ms. E. Smith, LMNDE
Mr. L. H. Manson, LMNDE

An OCE Coordinating Committee also worked enthusiastically to ensure the success of the Conference. This Committee consisted of:

Mr. C. F. Corns
Mr. R. L. Delyea
Mr. R. F. Malm, OCE Coordinator
Mr. L. G. Guthrie
Mr. D. B. Baldwin
Mr. R. A. McMurrer

The New Orleans District did a remarkable job in playing host to the Conference.

There were 13 division speakers, 25 moderators, two invited speakers, four technical speakers, and ten session chairmen, who shared the technical load of the Conference. Also, eight computer vendors showed their ware to the participants.

The editor would like to thank all the individuals who served on the committees and the speakers and the moderators for sharing their time and thoughts. Without them the Conference would not have been the success it was. Mr. Donald Dressler, LMVD, and Mr. William Price, WES, are especially thanked for their technical guidance and assistance.

This report was edited by Dr. N. Radhakrishnan, Research Civil Engineer, Computer Analysis Branch (CAB) and Special Technical Assistant, ADP Center, under the direct supervision of Mr. J. B. Cheek, Jr., Chief, CAB, ADP Center, and the general supervision of Mr. D. L. Neumann, Chief, ADP Center.

The Director of WES during the Conference and the preparation of this report was COL G. H. Hilt, CE. Mr. F. R. Brown was Technical Director.

CONTENTS

	<u>Page</u>
PREFACE	2
CONVERSATIONALLY ORIENTED REAL-TIME PROGRAM-GENERATING SYSTEM, CORPS by H. Wayne Jones	5
Introduction	5
Appendix A: Guidelines for CORPS Programs	7
Appendix B: Run Sequence Illustrating the Procedure for Using CORPS at WES	12
Appendix C: Example Program Construction and Usage on Facts	20
Appendix D: List of Programs Currently on WES G-635 CORPS	27
Appendix E: List of Programs Presently Being Adapted to WES G-635 CORPS	30
Appendix F: An Early Conception of the CORPS (Excerpts from a Conversationally Oriented Engineering Computer System by Robert L. Renner)	33
SYSTEMATIC EVALUATION AND REVIEW OF CRITERIA FOR HABITABILITY, SEARCH by Dale A. Bryant, R. Bruce Dains, and Janet H. Spoonamore	44
Acknowledgments	44
Introduction	44
Background	45
Example: Criminal Investigations Division Building	48
Future	53
INTERACTIVE COMPUTER GRAPHICS COMES OF AGE by Robert L. Hall	55
Slow Development	55
Results Thus Far	56
The Future and Its Problems	57
Recommendations	57
Appendix A: Pre- and Postprocessors for FEM Analysis	58
Appendix B: Rigid Frame Analysis	66
Appendix C: Display of Three-Dimensional Data	71
APPENDIX A: BIOGRAPHICAL SKETCHES OF AUTHORS	77

CONVERSATIONALLY ORIENTED REAL-TIME
PROGRAM-GENERATING SYSTEM

(CORPS)

by

H. Wayne Jones*

Introduction

The purpose of CORPS is to provide computational support for engineering planners, designers, and managers who require a responsive computer resource, but do not choose to be computer programmers. The user and the computer will conversationally interact to obtain the desired results.

The system was originally co-developed by Mr. Bob Renner, Office, Chief of Engineers (OCE), and Mr. Bob Brown, Waterways Experiment Station (WES), for programs in the field of hydraulics. OCE has given the Computer Analysis Branch (CAB) of WES the responsibility of locating outstanding engineering-computer programs in other engineering disciplines and incorporating them into CORPS. CAB is now in the process of locating these programs which are or can be of Corps-wide use. The authors of selected programs are asked to adapt them to CORPS with necessary funds being provided.

OCE has also given CAB the task of modifying the CORPS executive system to model the Federal Agencies Computer Time-Sharing System (FACTS). FACTS is available to the Corps on the Government Service Administration (GSA) Atlanta Data Processing Center G-400 time-sharing computer. This modified CORPS was available in late September 1975. Both the "old" and "new" CORPS will be maintained for a "transition" time period until users become familiar with the new version. Except for the log-on procedure and the execution (RUN) command the FACTS and the new CORPS will be identical.

During FY 76 another task of CAB is to establish the guidelines

* Civil Engineer, Computer Analysis Branch, ADPC, WES.

(standards) for the programs to be incorporated into CORPS. These guidelines are included in Appendix A.

The run sequence for using CORPS is given in Appendix B. Also included are a list of the soils and structures programs available, several briefs, and examples of the use of each command.

Appendix C shows the use of one FACTS program, X0003, on an example problem. The run sequence to construct the program, the brief, the interactive input, and the output are given.

Appendix D contains a list of the programs presently in the CORPS at WES.

Appendix E presents a list of the programs which are presently being added to the CORPS Library.

Appendix F contains excerpts from an article written by Robert L. Renner that outlines an early conception of CORPS.

Appendix A: Guidelines for CORPS Programs

The CORPS philosophy is to make the computer responsive to the user. The user should not be at the mercy of the computer, but should be in complete control at all times. The command language should allow the user to dictate the direction the program will take. If the response to any request is not apparent, the user should be able to issue a HELP command and be given enough information to make the correct response.

For any computer program library, such as CORPS, to function effectively, a set of minimum standards must be established for the programs contained in the library. These standards must be such that the library can distribute enough information to a user to allow satisfactory use of the program under normal conditions. These standards should make it apparent when duplicate programs exist. When similar programs are available, the advantage of each should be properly identified. Based on these ideas, the following guidelines for CORPS were defined.

Program Features

Programs should be able to run from a previously prepared data file or in a completely conversational mode with cues for the required input and additional help available, if needed.

Programs should have real-time data editing capabilities. This will include an option for display of part or all of the input data during execution of the program, but before the program uses the data. Correction of any part of the data will be possible at this time.

The units for input and output variables should be shown. If programs are based on a consistent set of units, the program should request the information needed to label output values.

The program should be capable of giving output on-line to the terminal or store it in a file to be listed later by the user.

The user should have the option of terminating the printing of voluminous information and control being returned to the previous level. The procedure for doing this is not available in standard G-600 FORTRAN. The CAB is presently investigating methods of doing this.

Hard Copy Documentation

A document should be supplied which will give the user a complete understanding of the program. This document will be kept on hand at the computer site. It will be mailed to the user on request. This should be the most comprehensive document available on the program. The document should strive to meet the OCE category A standards. The following information should be included, as a minimum.

- a. General introduction and an abstract
Computer used
Basic procedures used in program
Limitations
- b. Theory
Enough background to acquaint user with method used
- c. Program listing
- d. Flow chart - conceptual
- e. Input guide
Definition of variable
Sample input sequence
- f. Examples should demonstrate versatility of program and verify results when possible hand calculations should be given.
The following sections are desired:
 - (1) Physical problem definition
Description and figures
Should be preferably a Corps-type problem
 - (2) Input parameters
 - (3) Output listing
 - (4) Output interpretations

On-Line Documentation

A 50 character or less title of program to be included in the list of programs available through CORPS.

Through CORPS a BRIEF should be obtainable for all available programs. This BRIEF should include:

- a. Short but informative description of the program
- b. The limitations of the program
- c. A description of the input values required

d. A description of the output which is produced

A sample BRIEF that can be used as a guide is given on the following page.

Sample Brief for CORPS Program

I. DESCRIPTION

X0003 WILL ANALYZE BEAMS OF VARIABLE CROSS SECTION SUBJECTED TO ARBITRARY LOADING. THE BEAM IS DIVIDED INTO SEGMENTS CONNECTED AT NODAL POINTS. THE RELATIONSHIP BETWEEN APPLIED LOADS AND MOMENTS WITH DISPLACEMENTS AND ROTATIONS IS DETERMINED USING MOMENT-AREA PRINCIPLES.

II. LIMITATIONS

X0003 WILL HANDLE A BEAM THAT HAS BEEN DIVIDED INTO AS MANY AS 51 SEGMENTS. DATA FOR EACH BEAM IS ENTERED EITHER FROM A DATA FILE OR IN RESPONSE TO CUEING AT RUN TIME.

III. DATA

EACH BEAM IS DIVIDED INTO SEGMENTS. THE NODAL POINTS OF THE SEGMENTS ARE NUMBERED FROM LEFT TO RIGHT OF THE STRUCTURE WITH THE FIRST NODAL POINT BEING NUMBER 1. BEAM SEGMENTS ARE ALSO NUMBERED IN LIKE MANNER WITH THE FIRST SEGMENT BEING NUMBER 1. INPUT DATA FOR EACH STRUCTURE CONSISTS OF THE FOLLOWING:

A. JOB IDENTIFICATION (3 LINES MAX 60 CHAR/LINE)

B. NUMBER OF BEAM SEGMENTS.

C. DATA FOR EACH NODAL POINT.

1. NODAL POINT NUMBER.

2. RESTRAINT TYPE.

TYPE	X-DISP.	Y-DISP.
1	FREE	FREE
2	FREE	SPECIFIED
3	SPECIFIED	FREE
4	SPECIFIED	SPECIFIED

XXX REPEAT TYPE N ELEMENT XX TIMES

3. X-COORDINATE OF POINT (INCHES).

4. DISPLACEMENT OR LOAD (INCHES OR POUNDS).

5. ROTATION OR MOMENT (RADIAN OR INCH-POUNDS).

D. BEAM SEGMENT DATA.

1. BEAM SEGMENT NUMBER.

2. MOMENT OF INERTIA END I (INCHES**4).

3. MOMENT OF INERTIA END J (INCHES**4).

4. YOUNG'S MODULUS (POUNDS/IN.**2).

5. NUMBER OF TIMES BEAM SEGMENT IS REPEATED.

EXAMPLE INPUT FOR A BEAM 24 INCHES LONG, FIXED AT THE ENDS AND SUBJECTED TO A 1000 POUND LOAD AT THE CENTER. I=10 INCHES**4 & YOUNG'S MODULUS=30,000,000 POUNDS/IN.**2. THE BEAM IS DIVIDED INTO 2 SEGMENTS.

```
20 THIS IS A TEST SET OF DATA
25 THE JOB IDENTIFICATION CAN CONTAIN
30 ANY CHARACTER.
40 2
50 1,4,0,0,0
60 2,1,12,1000,0
70 3,4,24,0,0
80 1,300,300,30000000,2
```

Appendix B

This is a run sequence illustrating the procedure for using CORPS on the WES G-635 time-sharing computer. Each of the commands (HELP, MESSAGE, LIST, DIRECTORY, DELETE, BRIEF, CONSTRUCT, and STOP) are illustrated.

*** WES-TSS NOTIFIED ***

HIS SERIES 600 ON 09/17/75 AT 11.583 CHANNEL 7660

user id -R0KA0K149
password--
0909090909090909

SYSTEM ?FORTRAN
OLD OR NEW-NEW
READY

*RUN R0KA0K149/CORP,R
ENTER COMMAND(HELP,LIST,BRIEF,CONSTRUCT,DIRECTORY,DELETE,MESSAGE OR STOP
)

*** ? HELP
TYPE OF EXPLANATION?

ENTER:	TO GET:
SHORT	SHORT EXPL. OF SYSTEM
DETAIL	DETAILED EXPL. OF SYSTEM
DSYS	EXPL. OF DIRECTORY SYSTEM
NAME OF COMMAND	EXPL. OF COMMAND
END	RETURN TO COMMAND LEVEL
???	? DETAIL

THE CORPS SYSTEM IS DESIGNED TO ALLOW YOU TO USE THE ENGINEERING AND SCIENTIFIC PROGRAMS OF THE ENGINEERING LIBRARY WITHOUT ANY KNOWLEDGE OF PROGRAMMING. THE SYSTEM COMMUNICATES WITH YOU IN ENGLISH AND PREPARES THE PROGRAM TO RUN. FOR EACH PROGRAM YOU WANT TO RUN, THE SYSTEM CREATES A SMALL COMMANDS PROGRAM TO HANDLE THE DETAILS OF CALLING UP YOUR PROGRAM AND SUPPLYING IT WITH DATA. THE NAME OF THE SMALL, SYSTEM GENERATED, COMMANDS PROGRAM IS STORED FOR YOU IN A DIRECTORY FILE UNIQUE TO YOU. IN ORDER TO USE YOUR ENGINEERING PROGRAM YOU SIMPLY RUN THE COMMANDS PROGRAM AND IT TAKES CARE OF ALL DETAILS, ASKING YOU QUESTIONS IN ENGLISH ON THE TERMINAL IF IT NEEDS INFORMATION OR INSTRUCTIONS. TO RUN THE COMMANDS PROGRAM, TYPE RUN COMMANDS PROGRAM NAME AS: RUN HWJ01 . THIS CAN BE DONE ANYTIME THE CORPS RUNS.

YOUR DIRECTORY IS A FILE CREATED DURING YOUR FIRST CORPS RUN WHICH HOLDS THE NAMES OF COMMANDS PROGRAMS YOU HAVE CREATED, THE NAMES THE ENGINEERING PROGRAMS THEY RUN, THEIR RUN OPTIONS, AND THE DATES ON WHICH THEY WERE CREATED BY CORPS. A COMMANDS PROGRAM CREATED WITH CORPS IS AUTOMATICALLY PLACED IN YOUR DIRECTORY FILE. THUS, WHEN YOU USE CORPS, YOU MUST GIVE IT THE CORRECT FILE NAME WHEN ASKED. CORPS WILL ALSO ALLOW YOU TO LIST YOUR DIRECTORY AND REMOVE PROGRAMS FROM IT.

IN ORDER TO AID YOU IN SELECTING PROGRAMS AND DIRECTING CORPS, THE FOLLOWING COMMANDS ARE PROVIDED. THEY ARE ENTERED UPON REQUEST OF THE PROGRAM, SIGNIFIED BY A ****? CUE.

1. HELP

THIS COMMAND SHIFTS TO A SUBSYSTEM WHICH PRINTS EXPLANATION OF VARIOUS PARTS OF THE CORPS SYSTEM. TO GET A SHORT DESCRIPTION OF THE SYSTEM, TYPE SHORT, FOR A DETAILED EXPLANATION, TYPE DETAIL. TO GET AN EXPLANATION OF A COMMAND, TYPE THE NAME OF THE COMMAND. FOR AN EXPLANATION OF THE DIRECTORY SYSTEM TYPE DSYS. TO RETURN TO THE MAIN SYSTEM, TYPE END.

2. LIST

THIS COMMAND PROVIDES A LIST OF THE ENGINEERING PROGRAMS CURRENTLY AVAILABLE THROUGH CORPS. THIS LIST, WHICH IS CONSTANTLY EXPANDING, IS DIVIDED INTO SUB-AREAS, WHICH ARE IDENTIFIED BY A SINGLE ALPHABET LETTER, OR A LETTER AND A NUMBER. YOU CAN GET A LIST OF THE SUB-AREA CODES BY TYPING AN * WHEN THE PROGRAM ASKS FOR AN AREA CODE.

3. BRIEF

THIS COMMAND WILL PROVIDE A SHORT DESCRIPTION OF THE CAPABILITIES AND DATA REQUIREMENTS OF A PROGRAM IN THE CORPS SYSTEM. SOME PROGRAMS ARE "RUN ONLY" AND HAVE THE EXPLANATION BUILT IN WHEN THEY RUN. THESE MAY NOT ALLOW DESCRIPTION VIA BRIEF.

4. CONSTRUCT

THIS COMMAND WILL TAKE ENGINEERING PROGRAMS AND CREATE COMMANDS PROGRAMS TO HANDLE THE DETAILS OF RUNNING THEM. THE COMMANDS PROGRAM NAMES WILL THEN BE PLACED IN YOUR DIRECTORY FILE.

5. DELETE

THIS COMMAND SHIFTS TO A SUBSYSTEM WHICH ALLOWS YOU TO LIST ALL THE COMMANDS PROGRAMS AND THE ENGINEERING PROGRAMS THEY RUN WHICH ARE IN YOUR DIRECTORY. YOU CAN THEN DELETE EITHER THE ENTIRE DIRECTORY OR SELECTED PROGRAMS WITHIN IT. IF YOU DELETE THE ENTIRE DIRECTORY, THE DIRECTORY NAME WILL BE WIPE OUT AND YOU WILL NEED A NEW ONE AT YOUR NEXT CORPS RUN. IF YOU HAVE MORE THAN ONE DIRECTORY, YOU CAN SWITCH BETWEEN THEM.

6. DIRECTORY

THIS COMMAND ALLOWS YOU TO LIST ALL THE PROGRAMS IN YOUR DIRECTORY AS FOLLOWS:

COMMANDS	PROGRAM NAME	ENG. PROGRAM NAME	DATE CREATED
----------	--------------	-------------------	--------------

7. MESSAGE

THIS COMMAND ALLOWS YOU TO LEAVE A MESSAGE CONCERNING SYSTEM OPERATIONS OR PROGRAM DETAILS. IT ALSO GIVES YOU A CURRENT LIST OF THE NAMES OF PERSONNEL TO CONTACT FOR ASSISTANCE.

TO END LISTS OR EXIT SUBSYSTEMS ENTER END AT INPUT REQUEST, UNLESS OTHERWISE INSTRUCTED DURING RUN TIME. IF YOUR TERMINAL PERMITS UPPER AND LOWER CASE, ALWAYS ENTER ALPHA LETTERS IN UPPER CASE.

??? ? END

*** ? MESSAGE

YOU MAY LEAVE A MESSAGE CONCERNING SYSTEM PROBLEMS OR PROGRAMMING COMMENTS BY TYPING THE WORD 'CONTINUE' IN RESPONSE TO THE NEXT ? CUE. THIS MESSAGE WILL BE ANSWERED WITHIN THE NEXT FEW DAYS. FOR IMMEDIATE ASSISTANCE, TYPE THE WORD 'END' IN RESPONSE TO THE NEXT ? CUE AND THE WORD 'BYE' IN RESPONSE TO THE NEXT READY CUE. THEN CALL MR. WAYNE JONES AT FTS 601 636-3111 EXT-3758

? CONTINUE

ENTER YOUR NAME AND PHONE NUMBER ON ONE LINE

? WAYNE JONES FTS 601 636-3111 EXT-3758

ENTER YOUR MESSAGE A LINE AT A TIME IN RESPONSE TO A ? CUE.

TERMINATE YOUR MESSAGE WITH THE WORD 'END' AT THE BEGINNING OF THE LAST LINE.

? I WOULD LIKE TO SEE MORE STRUCTURES PROGRAMS IN CORPS

? END

*** ? LIST

###ENTER AREA CODE. ENTER AN * FOR LIST OF CODES. ? *

A0-COASTAL
C0-CONCRETE
D0-DREDGING
W0-EARTHWORK
E0-ELECTRICAL
J0-ECONOMICS
U0-GEODESORY & SURVEYING
G0-GEOLOGY
P0-GEOPHYSICS
B0-HYDROLOGIC
F0-HYDROELECTRIC
Y0-HYDROLOGY
H0-HYDRAULICS
H1- SPILLWAYS
H2- CONDUITS
H3- OUTLET WORKS
H5- LOCKS
H6- OPEN CHANNELS
H7- SPECIAL PROBLEMS
M0-MATHEMATICS
L0-MECHANICAL
N0-NUCLEAR
O0-OC FANOGRAPHY
Z0-OTHERS
R0-RESRVOIR REGULATION
T0-SANITARY
I0-SOILS
X0-STRUCTURAL

NUMBER OF PROGRAMS IN EACH AREA

AREA NUMBER

H0	2
H1	8
H2	8
H3	2
H5	1
H6	23
H7	2
H8	1
X0	7
I0	4
I9	1
X9	1

WOULD YOU LIKE ANOTHER LISTING? IF NOT, PLEASE TYPE END
 ### ? I0
 X0001 -BEAM1--PLANE BEAM ANALYSIS BY DIRECT STIFFNESS
 X0002 -TRUSS--PLANE TRUSS ANALYSIS BY DIRECT STIFFNESS
 X0003 -FRAME--PLANE FRAME ANALYSIS BY DIRECT STIFFNESS
 X0004 -GRID---GRID ANALYSIS BY DIRECT STIFFNESS
 X0005 -STRUSS-SPACE TRUSS ANALYSIS BY DIRECT STIFFNESS
 X0006 -GFRAME--ANALYSIS OF PLANAR RIGID FRAMES
 X0007 -PTRUSS--PLANE TRUSS ANALYSIS BY STIFFNESS MATRIX
 WOULD YOU LIKE ANOTHER LISTING? IF NOT, PLEASE TYPE END
 ### ? I0
 I0001 -COM62--LATERALLY LOADED PILE ANALYSIS
 I0002 -BFNT1--GROUP PILE ANALYSIS
 I0003 -PX4C3--AXIALLY LOADED PILE ANALYSIS
 I0004 -MAKE--GENERATE P-Y CURVES
 WOULD YOU LIKE ANOTHER LISTING? IF NOT, PLEASE TYPE END
 ### ? END

*** ? DIRECTORY
 ENTER YOUR DIRECTORY FILE NAME.
 ? HWJ100
 CURRENT DIRECTORY HWJ100

PROGRAM NAMES	FILE NAME	DATE
HWJ02	I0001	09/16/75
HWJ04	I0004	09/16/75

 *** ? DELETE
 CURRENT DIRECTORY HWJ100
 WOULD YOU LIKE TO
 LOOK - LIST THE PROGRAMS IN YOUR DIRECTORY
 ERASE - DELETE SOME PROGRAM
 ANOTHER - GO TO ANOTHER DIRECTORY
 END - GO TO MAIN PROGRAM
 LOOK, ERASE, ANOTHER, OR END
 ? LOOK

PROGRAM NAMES	FILE NAME	DATE
HWJ02	I0001	09/16/75
HWJ04	I0004	09/16/75

 LOOK, ERASE, ANOTHER, OR END
 ? ERASE
 DELETE ALL? (Y OR N)
 ? N
 ENTER PROGRAM NAMES TO BE DELETED. TYPE END TO
 TERMINATE ENTRY.
 ? HWJ04
 ? END
 LOOK, ERASE, ANOTHER, OR END
 ? LOOK

PROGRAM NAMES	FILE NAME	DATE
HWJ02	I0001	09/16/75

 LOOK, ERASE, ANOTHER, OR END
 ? END

*** ? BRIFF

\$\$\$ENTER PROGRAM. TYPE 'END' AS LAST NAME. ? X0001
THIS PROGRAM ANALYZES BEAMS BY DIRECT STIFFNESS METHOD.
EQUATIONS DERIVED FROM BEAM STIFFNESS MATRICES ARE
MODIFIED FOR KNOWN BOUNDARY CONDITIONS & SOLVED FOR UNKNOWN
DISPLACEMENTS & ROTATIONS--THUS, SHEARS & MOMENTS ARE
DETERMINED. INPUT REQUIREMENTS ARE BEAM SEGMENTS, NODAL
POINT NO., CODE FOR RESTRAINT TYPE, X COORDINATE,
DISPLACEMENT OR LOAD, ROTATION OR MOMENT, ELEMENT NO.
NODAL POINT NO. ASSIGNED TO END I, NODAL POINT NO.
ASSIGNED TO OPPOSITE END, MOMENT OF INERTIA, YOUNGS MODULUS.
OUTPUT PRODUCES A LIST OF DISPLACEMENTS & ROTATIONS
FOR EACH NODAL POINT AND THE SHEARS & MOMENTS AT THE
ENDS OF EACH BEAM ELEMENT.

FINISH

\$\$\$? X0006

THIS PROGRAM SOLVES FOR JOINT TRANSLATIONS & ROTATIONS
AND MEMBER END MOMENTS, SHEARS, & AXIAL LOADS FOR PLANAR
RIGID FRAMES HAVING A MAXIMUM OF 60 MEMBERS & 40 JOINTS.
EACH MEMBER MAY BE LOADED WITH UP TO 4 POINT LOADS
AND A LINEARLY VARYING DISTRIBUTION LOAD. ALL LOADS
MAY BE SKEWED. THE PROGRAM UTILIZES THE STIFFNESS
MATRIX METHOD FOR SOLUTION FOR JOINT DISPLACEMENTS.
THE STIFFNESS MATRIX FOR THE STRUCTURE IS CREATED &
USED FOR ANALYSIS OF DIFFERENT LOADING CONDITIONS.
INPUT CONSISTS OF THE GEOMETRY & ELASTIC PROPERTIES
OF THE STRUCTURE & THE LOADING OF THE STRUCTURE. OUTPUT
CONSISTS OF JOINT DISPLACEMENTS & ROTATIONS & MEMBER
END SHEARS, MOMENTS, & AXIAL LOADS.

FINISH

\$\$\$? I0004

PROGRAM GENERATES SOIL PRESSURE VS. PILE MOVEMENT RELATION-
SHIPS FOR CLAYS & SANDS BASED ON NONLINEAR TRIAXIAL
TEST DATA. INPUT CONSISTS ESSENTIALLY OF SOIL TYPE
AND ITS GEOMETRY. DATA MUST BE IN FREE-FIELD FORMAT
AND ENTERED AND SAVED IN A DATA FILE PRIOR TO RUNNING.
THE DATA MUST HAVE LINE NOS. A FILE FOR PROGRAM OUTPUT
MUST BE CREATED & SAVED PRIOR TO RUNNING PROGRAM. OUTPUT
CONSISTS OF A SERIES OF CURVES, VARYING WITH DEPTH,
OF SOIL RESISTANCE VS. DEFLECTION (P-Y CURVES) FOR
EACH MATERIAL.

FINISH

\$\$\$? END

*** ? CONSTRUCT

DIRECTORY FILE NAME? IF YOU DO NOT HAVE ONE, TYPE A CARRIAGE RETURN
? HWJ100

ENTER PROGRAM NAME ON ? CUE. TYPE 'END'
AS LAST NAME TO TERMINATE ENTRY.
? X0001

? X0002

? END

YOUR DIRECTORY (09/16/75)

PROGRAM NAME	FILE NAME	DATE CREATED
HWJ00	X0001	09/16/75
HWJ01	X0002	09/16/75

++ THE ABOVE SAVED PROGRAMS ARE ADDED TO YOUR DIRECTORY FILE HWJ100.

*** ? STOP

FOR ASSISTANCE AT ANY TIME, RECALL CORPS AND ASK FOR MESSAGE

*BYE

**resources used \$ 3.01, used to date \$ 5524.98= 46%

**time sharing off at 11.898 on 09/17/75

Appendix C: Example Program Construction and Usage on Facts

EXAMPLE BEAM SOLUTION USING PROGRAM X0003

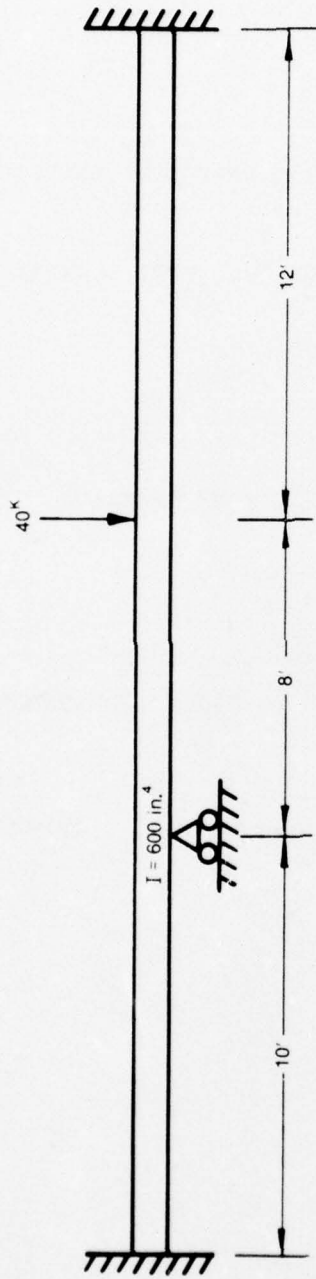

BEAM DIAGRAM

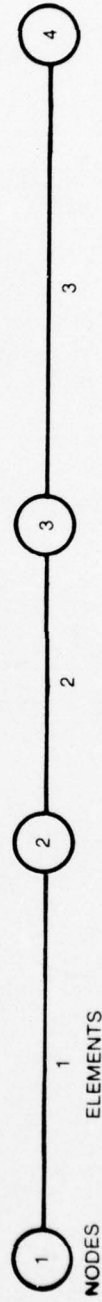

BEAM NODAL DIAGRAM

GSA 440 TIME-SHARING SYSTEM 1 ON AT - 09:24 PM:11 TTY:54

09/17/75. PRIVACY ACT AND THE RAMUS SYSTEM PLEASE LIST INFORM***

USER ID-- R100

PASSWORD

#####?

TYPE OLD OR NEW:OLD:FACTS***

READY

RUNNH

ENTER COMMAND(HELP,LIST,BRIEF,CONSTRUCT,DIRECTORY,DELETE,MESSAGE OR
*** ? CONSTRUCT

DIRECTORY FILE NAME? IF YOU DON'T HAVE ONE,TYPE A CARRIAGE RETURN.
?

ENTER PROGRAM NAME ON ? CUE. TYPE 'END'
AS LAST NAME TO TERMINATE ENTRY.
? X0003

? END

ENTER NEW DIRECTORY PREFIX(3 CHAR). EX. YOUR INITIALS

? HWJ

YOUR DIRECTORY(WED 09/17/75)

PROGRAM NAME	FILE NAME	RUN OPTION
HWJ00	X0003	RUNNH

++THE ABOVE SAVED PROGRAMS ARE ADDED TO YOUR DIRECTORY FILE HWJ100.

\$\$\$? END

*** ? BRIEF

\$\$\$ENTER PROGRAM NAME. TYPE 'END' AS LAST NAME. ? X0003

I. DESCRIPTION

X0003 WILL ANALYZE BEAMS OF VARIABLE CROSS SECTION SUBJECTED TO ARBRITARY LOADING. THE BEAM IS DIVIDED INTO SEGMENTS CONNECTED AT NODAL POINTS. THE RELATIONSHIP BETWEEN APPLIED LOADS AND MOMENTS WITH DISPLACEMENTS AND ROTATIONS IS DETERMINED USING MOMENT-AREA PRINCIPLES.

II. LIMITATIONS

X0003 WILL HANDLE A BEAM THAT HAS BEEN DIVIDED INTO AS MANY AS 51 SEGMENTS. DATA FOR EACH BEAM IS ENTERED EITHER FROM A DATA FILE OR IN RESPONSE TO CUFING AT RUN TIME.

III. DATA

EACH BEAM IS DIVIDED INTO SEGMENTS. THE NODAL POINTS OF THE SEGMENTS ARE NUMBERED FROM LEFT TO RIGHT OF THE STRUCTURE WITH THE FIRST NODAL POINT BEING NUMBER 1. BEAM SEGMENTS ARE ALSO NUMBERED IN LIKE MANNER WITH THE FIRST SEGMENT BEING NUMBER 1. INPUT DATA FOR EACH STRUCTURE CONSISTS OF THE FOLLOWING:

A. JOB IDENTIFICATION(3 LINES MAX 60 CHAR/LINE)

B. NUMBER OF BEAM SEGMENTS.

C. DATA FOR EACH NODAL POINT.

1. NODAL POINT NUMBER.

2. RESTRAINT TYPE.

TYPE X-DISP. Y-DISP.

1 FREE FREE

2 FREE SPECIFIED

3 SPECIFIED FREE

4 SPECIFIED SPECIFIED

NXX REPEAT TYPE N ELEMENT XX TIMES

3. X-COORDINATE OF POINT(INCHES).

4. DISPLACEMENT OR LOAD(INCHES OR POUNDS).

5. ROTATION OR MOMENT(RADIANS OR INCH-POUNDS).

D. BEAM SEGMENT DATA.

1. BEAM SEGMENT NUMBER.

2. MOMENT OF INTERIA END I(INCHES**4).

3. MOMENT OF INTERIA END J (INCHES**4).

4. YOUNG'S MODULUS (POUNDS/IN.**2).

5. NUMBER OF TIMES BEAM SEGMENT IS REPEATED.

EXAMPLE INPUT FOR A BEAM 24 INCHES LONG, FIXED AT THE ENDS AND SUBJECTED TO A 1000 POUND LOAD AT THE CENTER. I=10 INCHES**4 & YOUNG'S MODULUS=30,000,000 POUNDS/IN.**2. THE BEAM IS DIVIDED INTO 2 SEGMENTS.

20 THIS IS A TEST SFT OF DATA
25 THE JOB IDENTIFICATION CAN CONTAIN
30 ANY CHARACTER.
40 2
50 1,4,0,0,0
60 2,1,12,1000,0
70 3,4,24,0,0
80 1,300,300,30000000,2
\$\$\$? FND

*** ? STOP

FOR ASSISTANCE AT ANY TIME, RECALL FACTS AND ASK FOR MESSAGE
STOP

RUNNING TIME: 12.7 SECS I/O TIME : 11.0 SECS

OLD:HWJ00

READY
RUNNE

ENTER DATA FILE NAME. IF NONE TYPE CARRIAGE RETURN.

?

WANT SHORT CUES(YES OR NO).

? NO

ENTER DATA FOR ONE STRUCTURE AT A TIME IN RESPONSE TO CUES

ENTER JOB IDENTIFICATION (3 LINES WITH 60 CHAR. PER LINE.

ENTER CARRIAGE RETURN ONLY TO BLANK OUT A LINE.

* 1 ? EXAMPLE PROBLEM NO.1

* 2 ? SOLUTION OF FIXED END BEAM USING DIRECT STIFFNESS METHOD

* 3 ? NEGLECT WEIGHT OF BEAM

ENTER NUMBER OF BEAM SEGMENTS(MAX 51).

4 ? 3

ENTER NODAL POINT DATA (SEPARATE BY COMMAS).

NUMBER LEFT TO RIGHT BEGINNING WITH NUMBER 1.

1.NODAL POINT NUMBER.

2.RESTRAINT TYPE.

TYPE X-DISP. Y-DISP.

1 FREE FREE.

2 FREE SPECIFIED.

3 SPECIFIED FREE.

4 SPECIFIED SPECIFIED.

NXX REPEAT TYPE N ELEMENT XX TIMES.

3.X-COORDINATE OF POINT (INCHES).

4.DISPLACEMENT OR LOAD (INCHES OR POUNDS).

5.ROTATION OR MOMENT (RADIAN OR INCH-POUNDS).

@ 5 ? 1,4,0,0,0

@ 6 ? 2,2,120,0,0

@ 7 ? 3,1,216,40000,0

@ 8 ? 4,4,360,0,0

ENTER BEAM SEGMENT DATA (SEPARATE BY COMMAS).
 NUMBER LEFT TO RIGHT BEGINNING WITH NUMBER 1.

1. BEAM SEGMENT NUMBER.
 2. MOMENT OF INERTIA END I (INCHES**4).
 3. MOMENT OF INERTIA END J (INCHES**4).
 4. YOUNG'S MODULUS (POUNDS/IN**2).
 5. NUMBER OF TIMES BEAM SEGMENT IS REPEATED.

\$ 9 ? 1,600,600,30000000,1
 \$ 10 ? 2,600,600,30000000,1
 \$ 11 ? 3,600,600,30000000,1

WANT TO CORRECT ANY DATA BEFORE SOLVING PROBLEM (YES OR NO).
 1 ? NO

EXAMPLE PROBLEM NO.1
 SOLUTION OF FIXED END BEAM USING DIRECT STIFFNESS METHOD
 NEGLECT WEIGHT OF BEAM

NUMBER OF NODES= 4 NUMBER OF BEAM SEGMENTS= 3

NODE	RESTRAINT	X	U	V
1	4	0.00	0.00	0.00
2	2	120.00	0.00	0.00
3	1	216.00	40000.00	0.00
4	4	360.00	0.00	0.00

SEGMENT	I	J	MOMENT OF INERTIA	YOUNG'S MODULUS
1	1	2	600.00	30000000.00
2	2	3	600.00	30000000.00
3	3	4	600.00	30000000.00

VERTICAL DISPL OF(INCHES)	1 =	0.00000
ROTATION OF (RAD)	1 =	0.00000
VERTICAL DISPL OF(INCHES)	2 =	0.00000
ROTATION OF (RAD)	2 =	0.00154
VERTICAL DISPL OF(INCHES)	3 =	0.19464
ROTATION OF (RAD)	3 =	0.00055
VERTICAL DISPL OF(INCHES)	4 =	0.00000
ROTATION OF (RAD)	4 =	0.00000

SEGMENT	V AT I (POUNDS)	M AT I (INCH-POUNDS)	V AT J (POUNDS)	M AT J (INCH-POUNDS)
1	11520.	460800.	-11520.	921600.
2	-23040.	-921600.	23040.	-1290240.
3	16960.	1290240.	-16960.	1152000.

MODIFY INPUT (YES OR NO).
? NO

RERUN, STOP, NEXT, DELETE OR OTHER
? STOP

RUNNING TIME: 11.6 SECS I/O TIME : 13.5 SECS

READY
BYE

OFF AT 11:38

Appendix D: List of Programs Currently on WES G-635 CORPS

Hydraulic Programs Presently on CORPS

H0011 R0HP1	F52-KINEMATIC VISCOSITY OF WATER-EFFECTS OF TEMPERATURE
H0114 R0HP1	F52-BRIDGE PIER LOSSES-RECT OR TRAP SECT-ANY FLOW CLASS
H1102 WESLIB	F41*STANDARD HIGH SPILLWAY CREST COORDINATES
H1103 WESLIB	F52*STAGE-DISCH RELATION FOR STANDARD SPILLWAY(UNGATED)
H1105 WESLIB	F52*STAGE-DISCH RELATION-SPILLWAY CREST-UNCONTROLLED FLOW
H1111 WESLIB	F52*STANDARD SPILLWAY CREST WATER SURFACE ELEV-HIGH DAM
H1116 WESLIB	F49*STANDARD SHAPE SPILLWAY CREST PRESSURE-HIGH DAM
H1170 WESLIB	F51*HIGH SPILLWAY CREST COORDINATES- 3-1 UPSTREAM FACE
H1180 WESLIB	F51*HIGH SPILLWAY CREST COORDINATES- 3-2 UPSTREAM FACE
H1190 WESLIB	F51*HIGH SPILLWAY CREST COORDINATES- 3-3 UPSTREAM FACE
H2030 WESLIB	F47*DISCH-PRESSURE CONDUITS-DARCY-WEISBACH FORMULA
H2035 WESLIB	F40*DISCH-PRESSURE CONDUITS-MANNING FORMULA
H2040 WESLIB	F42*GEOMETRIC ELEMENTS OF A HORSESHOE CONDUIT
H2041 WESLIB	F44*GEOMETRIC ELEMENTS OF A RECTANGULAR CONDUIT
H2042 WESLIB	F40*GEOMETRIC ELEMENTS OF AN OBLONG CONDUIT
H2043 WESLIB	F45*DISCHARGE IN HORSESHOE COND(MAN OR DAR FORM)
H2044 WESLIB	F40*DISCHARGE FOR RECT. CONDUIT(DAR OR MAN)
H2045 WESLIB	F52*DISCH IN AN OBLONG OR CIRC CONDUIT-MANN OR DAR FORM
H3106 WESLIB	F52*STANDARD DISCH RELATION-TAINTER GATE ON CURVE CREST
H3201 WESLIB	F50*DISCH FOR PARTLY OPEN VERTICAL LIFT CONDUIT GATES
H5320 R0HP1	F41-LOCK FILL AND EMPTY--SYMMETRICAL SYSTEMS
H6001 WESLIB	F44*GEOMETRIC ELEMENTS-TRAP,RECT,TRIA-CHANNEL
H6002 WESLIB	F39*GEOMETRIC ELEMENTS OF CIRCULAR CONDUIT
H6005 R0HP1	F51-GEOMETRIC ELEMENTS OF A GENERAL CHANNEL CROSS-SECT
H6110 WESLIB	F49*NORMAL DEPTH-TRAP,RECT,TRIA SECT-MANNING FORMULA
H6111 WESLIB	F52*NORMAL DEPTH AND VELOCITY-CIRC CONDUIT-MANN FORMULA
H6112 WESLIB	F35*NORMAL DISCHARGE- MANNING FORMULA
H6113 WESLIB	F47*NORMAL DEPTH-TRAP,RECT,TRIA SECT-CHEZY FORMULA
H6114 WESLIB	F32*NORMAL DISCHARGE- CHEZY FORMULA
H6115 WESLIB	F45*NORMAL DEPTH AND VELOCITY-CIRC CONDUIT-CHEZY
H6116 WESLIB	F41*NORMAL DISCHARGE-COLEBROOK WHITE FORMULA
H6117 WESLIB	F49*NORMAL DEPTH-TRAP,RECT,TRIA SECT-COLEBROOK WHITE
H6118 WESLIB	F50*NORMAL DEPTH AND VEL-CIRC CONDUIT-COLEBROOK WHITE
H6122 R0HP1	F33-CONJUGATE DEPTH-CIRCULAR SECTION
H6123 R0HP1	F39-CONJUGATE DEPTH-TRAP,RECT,TRIA-SECTION
H6124 R0HP1	F49-SPECIFIC FORCE AND ENERGY-TRAP,RECT,TRIA-SECTION
H6125 R0HP1	F43-SPECIFIC FORCE AND ENERGY-CIRCULAR SECTION
H6140 WESLIB	F48*CRITICAL DEPTH AND VELOCITY-TRAP,RECT,TRIA SECT
H6141 WESLIB	F49*CRITICAL DEPTH AND VELOCITY FOR CIRCULAR CONDUIT
H6201 WESLIB	F47*FRICTION SLOPE-ANY FLOW SECT-MANNING, CHEZY, OR
& 623 COLEBROOK	WHITE FORMULA
H6208 WESLIB	F44*FLOW PROFILE-CIRC CONDUIT-MANNING,CHEZY, OR
& 623 COLEBROOK	WHITE FORMULA
H6209 WESLIB	F49*FLOW PROFILE-PRISMATIC CHANNEL-MANNING,CHEZY, OR
& 623 COLEBROOK	WHITE FORMULA
H6210 R0HP1	F25-LDR-I BACKWATER PROFILES
H6602 R0HP1	F52-SPIRAL BANKED CURVE-SUPERCritical FLOW-RECT.X SECT
H7133 R0HP1	F47-SELECTIVE WITHDRAWAL-SINGLE OR MULTIPLE OUTLET
& 740 OPERATIONS	WITH ORIFICE AND/OR WIER FLOW
H7220 WESLIB	F51*PROSION AT CULVERT OUTLETS AND RIPRAP REQUIREMENTS
H8000 R0HP1	F30 DEVELOPMENT PROGRAM FOR R0HP1

Structures Programs Presently on CORPS

I0001 WESLIB	F50-BEAM1--PLANE BEAM ANALYSIS BY DIRECT STIFFNESS
X0002 WESLIB	F51-TRUSS--PLANE TRUSS ANALYSIS BY DIRECT STIFFNESS
X0003 WESLIB	F50-FRAME--PLANE FRAME ANALYSIS BY DIRECT STIFFNESS
X0004 WESLIB	F44-GRID---GRID ANALYSIS BY DIRECT STIFFNESS
X0005 WESLIB	F52-STRUSS-SPACE TRUSS ANALYSIS BY DIRECT STIFFNESS
X0006 WESLIB	F43-GFRAME--ANALYSIS OF PLANAR RIGID FRAMES
X0007 WESLIB	F52-PTRUSS--PLANE TRUSS ANALYSIS BY STIFFNESS MATRIX

Soils Programs Presently on CORPS

I0001 WESLIB	F41-COM62--LATERALLY LOADED PILE ANALYSIS
I0002 WESLIB	F30-BENT1--GROUP PILE ANALYSIS
I0003 WESLIB	F39-PX4G3--AXIALLY LOADED PILE ANALYSIS
I0004 WESLIB	F29-MAKE--GENERATE P-Y CURVES
I9999 R0KA0K149	F31-DEVELOPMENT PROGRAM FOR CAB
I9999 R0KA0K149	F31-DEVELOPMENT PROGRAM FOR CAB

Appendix E: List of Programs Presently Being
Adapted to WES G-635 CORPS

The following programs, written by William Ashton, Rock Island District, have been modified for inclusion in CORPS. As soon as documentation is received in WES they will be made available through CORPS.

- a. Moments, Shears and Reactions for Moving Loads on Simple Spans.
- b. Simple Span Highway Bridge Analysis.
- c. Influence Ordinates and Areas and Design Moments on Continuous Beams.
- d. Analysis of Non-Composite Steel Girder.
- e. Analysis of Composite Steel Girder.

The New Orleans District has been given funds to modify the following programs to be included in CORPS during FY 76.

- a. Cantilever Retain Wall Stability.
- b. Vertical Stress Induction.
- c. Centerline Analysis.
- d. Slope Stability Analysis by the Method of Wedges.
- e. Stability Analysis Considering Uplift by the Wedge Method.
- f. Beams (Shear, Moment, Deflection).

The Albuquerque District has been given funds for adapting the following program, "Concrete Box Culvert Frame Analysis and Design," to CORPS in FY 76.

The Soils Laboratory at WES has been funded to adapt two soils programs to CORPS during FY 76.

The Computer Analysis Branch at WES has proposed the following programs for addition to CORPS during FY 76.

- a. Concrete General Flexural Analysis (CGFA).
- b. Pre-processor for CGFA.
- c. Skin Plate Analysis and Design.
- d. A pre- and post-processor for GFRAME (GFRAME is already in CORPS).

Selected programs written by Dr. H. B. Wilson, Expert, WES ADP Center:

- e. Beam analysis - analysis of a continuous beam with variable restraints; point loads, trapezoidal loads of variable length

and position, support movements and springs.

- f. Cross-section geometry - calculates area and location of the center of gravity of an area defined by straight lines and arcs.

Besides the fundings mentioned above, CAB has funds remaining to find and modify other programs which are or can be of Corps-wide use. A major source for these programs is the Corps-wide Conference on Computer-Aided Design in Structural Engineering, 22-26 September 1975, held in New Orleans, Louisiana.

Appendix F: An Early Conception of the CORPS

EXCERPTS FROM A CONVERSATIONALLY ORIENTED
ENGINEERING COMPUTER SYSTEM

by

Robert L. Renner*

Introduction

The Corps of Engineers installed its first electronic digital computer in the late 1950's. Today it owns or leases many electronic computers. The computer is used in some manner in a great number of Corps functions. It is considered to be an essential engineering tool by many Corps engineers.

In adapting the computer to engineering problem solving, the Corps has made mistakes; it has had false starts and followed paths that have led to frustration; but it has learned. First, it has learned that although the computer is a powerful tool, it is not the answer to every problem. Second it has learned when to apply the computer and when to seek more efficient manual or semiautomatic methods. Third, it has learned that it is better to make the computer speak the language of the user rather than to make the user speak the language of the computer.

A Growing Corps Computer Potential

The Corps has been moderately successful in applying the computer to engineering problem solving. However, it now appears that the Corps is standing on the threshold of great promise for making the computer the indispensable engineering tool it is capable of becoming. This optimism is attributed to four significant factors:

- a. A new generation of computer-oriented engineers are now assuming positions of responsibility within the Corps of Engineers. Many of them have been associated with the Corps' early experience in adapting the computer to engineering applications and they appreciate its power as a design aid; others are

* Retired Chief, Computation and Analysis Branch, Civil Works Directorate, OCE.

college trained in computer science and bring with them a depth of understanding in computer technology.

- b. New and sophisticated computer equipment is becoming available; equipment which is faster, easier to use, and less expensive to operate than ever before. A particularly significant equipment development has been the time-sharing computer system.
- c. A library of meaningful engineering computer programs is being developed within the Corps of Engineers. Programs in this library will have been documented, thoroughly tested, and approved by competent authority for use in planning, design, or construction.
- d. A conversationally oriented engineering computer system has been developed which will allow any engineer to use all of the programs in the Corps library with an absolute minimum of effort. This system provides linking and chaining of computer programs and it communicates with the user in his own discipline-oriented language.

The development of a meaningful computer potential within the Corps of Engineers began in 1965. It started with an in-depth study of our engineering processes and the identification of problems associated with computerizing these processes. The engineer normally receives assignments in the form of mission requirements. These are used by the engineer to develop project concepts. Project concepts form the basis for design criteria; design criteria are used in making design decisions and in developing a specific design. This design is evaluated to determine how well it satisfies mission requirements. If inadequacies exist, the project concepts are altered and the design process is repeated until a satisfactory design is achieved.

Most aspects of this process can be computerized provided the engineer can effectively communicate with the computer. This communications problem has been difficult because of these factors.

- a. The engineer understands the language and processes of his profession. His principal concern is solving engineering problems. If we give him a computer as a design aid, but force him to become a computer programmer in order to use it, we have more than likely complicated the design process.
- b. Since engineering is an iterative process--the computer must be accessible and capable of responding to the engineers' requirements in a relatively short period of time. Otherwise, it can become a liability rather than an asset for the next

iteration in the design process is always dependent upon the results of the previous one.

- c. Engineering is not only an iterative process, but one which requires ingredients of experience and creative ability in order for the design to satisfy the mission need. The computer can easily provide computational speed, analyses, and comparisons in problem solving (some experience can be programmed into the computer but that is often limited because of the great number of variables involved) and man can provide the experience and creative ability. A proper man/machine balance is often difficult to achieve, but once it has been done, it provides an unbeatable problem solving combination.
- d. There are no universally acceptable standards for developing engineering computer programs. The data input requirements, data element sizes, variable name assignments, solution techniques, and data output formats are usually unique to each program. This nonuniformity between programs makes it difficult for the normal user to acquire and use programs developed by others. Although this problem is not restricted to engineering, it is especially critical in problem solving where the solution technique is the predominant factor. The engineer user must be satisfied that the computer solution is valid for his set of conditions; this requires that he know what parameters and assumptions were used in the program's development.

Exploiting the Computer as an Engineering Tool

Once we had evaluated our processes and identified those computer problems which were inhibiting us from fully exploiting the computer as an engineering tool, we could explore techniques for solving them. In reviewing the problems it was found that they could be grouped into three principal areas: (a) providing better and more easily accessible hardware, (b) developing a library of computer programs that would be pertinent to our work and which could be relied upon to produce satisfactory solutions, and (c) making it easier for the engineer to communicate with and use the computer. Corps goals have been established and are being implemented to address these problem areas.

Computer Hardware

The first major goal established has been to make the computer more

easily accessible to the engineer professional. A program to upgrade Corps of Engineers computer facilities was developed in 1965. Its implementation began in 1969 and now every Corps office has an installed computer or access to one. In addition, a large scientific computer was installed in the Corps' Waterways Experiment Station in Vicksburg, Mississippi, in 1973. This machine is available, via time-sharing, to all other Corps facilities. The acquisition of satisfactory terminal devices, at design level, which will communicate with installed or leased equipment, will provide every engineer the power of the computer for problem solving.

Computer Library

The second major goal has been the development of a Corps-wide engineering computer programs library. In developing the system to achieve this goal, maximum use of previous in-house work, as well as that of others, is being made in the applications area. The program now being implemented consists of three efforts:

- a. An Engineering Computer Programs Library has been established at the WES. It serves as a repository and distribution center for all agency-approved computer programs.
- b. Approval procedures have been established by which all engineering computer programs must pass in order for them to become a part of the library. Those programs which attain approved status may be used in design without the designer being required to document his solution technique in a design memorandum; he need only refer to the program by number and provide the input used for the problem solution.
- c. Engineering computer program documenting standards have been established and published.

Communicating with the Computer

The last major goal has been to make it easier for the engineer to communicate with and use the computer. The design and implementation of a program to achieve this goal has been particularly difficult. Our first efforts have been two-fold:

- a. An Engineer Computer Training Program has been developed. It defines a minimum level of computer competence for every engineer. The type of training and level of difficulty is commensurate with the engineers' duties and responsibilities. The implementation of this program will assure the Corps of a high degree of computer competence among its engineering staff.
- b. A conversationally oriented engineering computer system has been developed which will allow an engineer to use any program or group of programs in the library with an absolute minimum of effort. This system communicates with the user in his own language and produces results that he can understand. The development of the system represents a breakthrough in our search to make the computer a tool for every engineer. The system operates in real-time and has been titled as "CORPS" (an acronym for Conversationally Oriented Real-Time Program-Generating System).

"CORPS" Concepts

The development of the "CORPS" is perhaps our most promising effort for creating a properly balanced engineer/computer design team. The statement that the system was developed is misleading since the original systems work was directed along other lines. It is perhaps more explanatory to say that the system was discovered.

It all began when it was decided that a survey would be made of the Corps of Engineers to determine what computer programs were in use for hydraulic design. This program envisioned that all the hydraulic design programs would be collected, an engineering evaluation made of them to determine which of them could be used Corps-wide, and those considered as appropriate would be documented and placed in the WES Library for distribution.

In order for the hydraulic design engineer to use the programs in the library, either as individual programs or in some group order, it was usually necessary for him to write a small computer program. The writing of these small programs was not too difficult, provided the user was a computer programmer, since all the basic programs were written in a common language, FORTRAN, and they were well documented. However, as every programmer knows it is easy to make mistakes in coding no matter how simple the task, so every new program required some debugging and

testing prior to its being used in production.

The development of these hydraulic design subroutines, to be used as a system, was clearly a step in the right direction, for each program furnished was well defined, tested, and could be relied upon to provide a satisfactory answer if used within the limits imposed. However, the requirement that the hydraulic designer be a computer programmer in order to use the system was exactly opposite to what we had been preaching; we were, in fact, compounding the design effort. Realizing this, an Executive System was developed to provide the communications link between the set of system subroutines and the engineer user. The Executive System required that every subroutine in the system contain a preamble in FORTRAN language. This preamble contained a list of parameters required to run the program, any input, output, or computation options available, variable definitions, a brief summary of the program and any other data pertinent to making the system operate. The Executive System was capable of reading the preamble, converting it into English, and presenting system requirements to the user in hydraulic terms. The engineers' responses were used by the Executive System to write a new program containing all the basic subroutines requested, as overlays, in the new program. The Executive System was performing the same programming function that the engineer user had previously performed but it could do it flawlessly. It would automatically generate a program, including all applicable subprograms, in response to engineering language input. We had succeeded in relieving the hydraulic engineer of the programming task when using subroutines in our system.

The mechanics for using the system were quite elementary. The engineer would access the computer via a time-sharing computer terminal. He would converse with the computer in English; telling it which programs he wanted to run and in what order, supplying the inputs demanded by the computer and reviewing results as necessary. The entire process could be easily learned by any hydraulic engineer in just a few minutes. The basic subroutines in the system were all developed by other hydraulics engineers so they were written in the language of the user. New hydraulic design programs were added to the system as time permitted. The only

requirement for adding new programs was that each of them contain a preamble conforming to system specifications. As time passed, programs other than hydraulic design were demanded by the users. Thus, the system we now call "CORPS" was born.

System Details

The present "CORPS" was developed for the General Electric 600 series computer. A similar system, FACTS (Federal Agencies Computer Time-Sharing System) is available on the GE-400 series computer. It is operational on time-sharing only. Later adaptations will be made to apply the system to other computers.

A system schematic of "CORPS" is shown in Figure 1.

Operational details of the system are as follows (circled number refers to activities shown in Figure 1):

- a. Sequence I. If the user wishes to develop a new FORTRAN computer program which utilizes any subroutine or group of subroutines in the program library, he starts with Sequence I. Thus, ① he addresses the computer via a remote terminal device and tells it to run the Executive Program. The computer asks the user if he would like system details or subroutine content. If he does, the computer accesses the disc library ② to retrieve the data and displays it at the terminal ③. The computer then asks the user to enter the subroutines desired and in the order he wishes to run them. He can specify the same subroutine more than once if he so desires. Using these input data, the computer accesses the disc FORTRAN Library ② to retrieve the programs in run order. It interprets the preamble for each program and asks the user to supply any data required to assemble the new program. The Executive System utilizes user supplied data and the preamble content to develop a new FORTRAN IV program. This is stored on disc storage ④. The program developed by the Executive System is a valid FORTRAN IV computer program and can be used on any system which will accept GE FORTRAN. As previously mentioned, the conversation between the user and the computer is in English language and specifically oriented to the discipline involved.
- b. Sequence II. If the user wishes to compile an object program from the source program he has just created, or from a source program he had previously created, he would follow Sequence II. Thus, ⑤ the user asks the computer to run his program. ⑥ The computer inputs a copy of the program from disc storage, it inputs a copy of the basic subroutines from the disc library

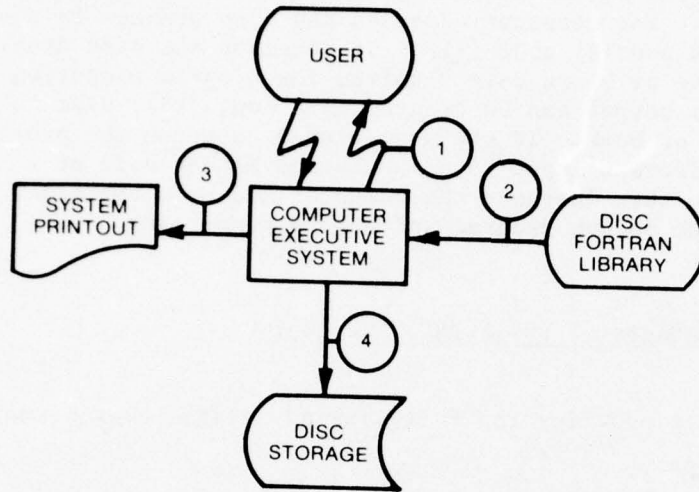

SEQUENCE I

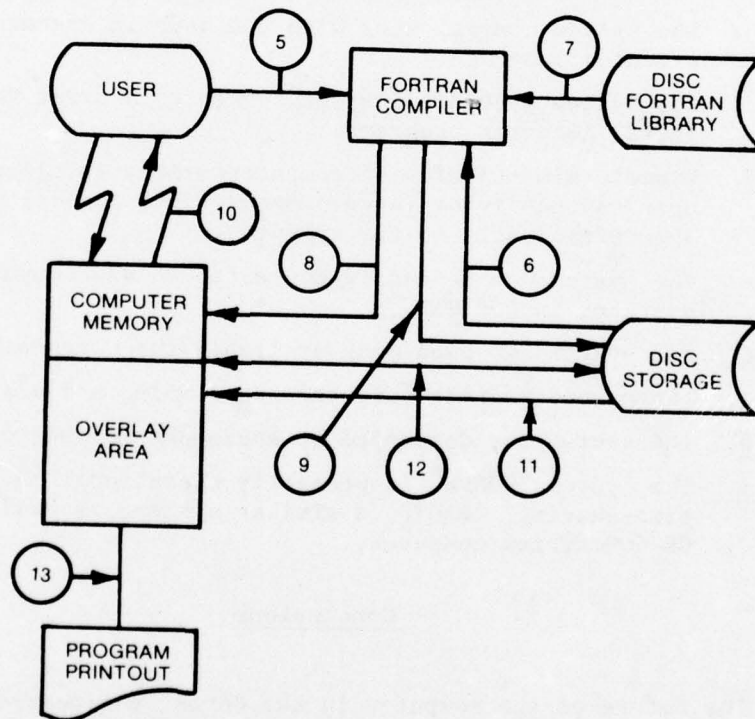

SEQUENCE II

Figure 1. System schematic

⑦. It compiles the program and stores the object program back on disc storage ⑨ and in computer memory ⑧. ⑩ The computer runs the object program either with or without input from the user. The computer accesses the disc storage to run subroutines in overlay mode ⑪. It accesses the disc storage to retrieve or store data required for program execution ⑫. Program output can be printed hard copy ⑬, disc storage ⑫, or both. If the user wishes to rerun the program using different input data, he begins Sequence II at Step ⑩. In this instance the computer accesses the disc storage for the object program and begins processing.

Advantages of the "CORPS" Concept

The "CORPS" concept provides the following advantages over normal computer library concepts:

- a. Any user can communicate with the computer in an effective manner without becoming a computer programmer.
- b. The system communicates with the user in his own discipline-oriented language.
- c. The system provides instant access to a great variety of meaningful computer programs.
- d. Dynamic dimensioning of computer memory is allowed. Thus, the user can subdivide large programs into logical units and run them efficiently on the computer.
- e. The system can be easily converted to any computer since it operates in FORTRAN.
- f. The system has been made available for Corps-wide use.
- g. The system reduces computer programming and debugging time.
- h. The system was developed by engineers for engineers.
- i. The system "CORPS" is presently operational on GE-600 series time-sharing. FACTS, a similar system, is available on the GE-400 series computer.

Conclusions

The future of the computer in the Corps' engineering design business can be assured if it becomes a truly useful device for every problem solver. In an effort to make the computer an indispensable engineering tool, the Corps is acquiring responsive computer equipment, building a

library of meaningful and useful computer programs, training engineers in computer technology, and providing them with a machine which speaks his own language.

SYSTEMATIC EVALUATION AND REVIEW
OF CRITERIA FOR HABITABILITY
(SEARCH)

by

Dale A. Bryant*

R. Bruce Dains**

Janet H. Spoonamore†

Acknowledgments

The work leading to the development of SEARCH was performed at the Construction Engineering Research Laboratory under Colonel Melvyn D. Remus, Commander/Director of CERL, Dr. L. R. Shaffer, Deputy Director, Dr. Robert Dinnat, Chief of the Facilities Habitability and Planning Division, and Mr. Robert Porter, Chief of the Architecture Branch.

The authors wish to express appreciation to the technical monitor (at the Office of the Chief of Engineers, Washington, D. C.) Mr. Robert Shibley without whose enthusiastic assistance and support the progress reported to date would not have been possible. Credit is also due Mr. Guy Weinzapfel of Massachusetts Institute of Technology whose original contribution provided the basis for SEARCH.

Introduction

SEARCH is an interactive design and evaluation tool which is currently finding useful application in the Corps of Engineers. SEARCH incorporates a degree of realism and sophistication which assures early benefits from its use. In this application of computer-aided architectural design, the computer performs a rigorous, unbiased evaluation of building layouts based on objective design criteria. The architect is

* Research Architect, Architecture Branch, CERL.

** Operations Research Analyst, Architecture Branch, CERL.

† Operations Research Analyst, CERL.

supplemented, not supplanted. Both man and machine perform in their optimum roles.

Background

The U. S. Army Corps of Engineers oversees one of the largest sustained building programs in the world, providing all permanent facilities for the Army as well as many buildings for the Air Force. For 80% of this work the Corps acts as a client, contracting for design services with Architect/Engineer firms; the remaining 20% is designed in-house. Each year new barracks, mess halls, recreation centers, and other military facilities are designed and then the next year they are designed again for other installations.

While the architectural program for each building type remains relatively stable, it is desirable to vary individual building to account for differences between specific site situations, climates, and technological solutions. A series of documents called Design Guides DG 1110-345-lxx, specifying detailed functional criteria for each of several building types is currently under development at OCE. Standard design criteria from DOD 4270 and Design Guides, together with project-specific criteria from program development brochures are given to the architect in the form of engineering instructions.

The resulting plans must undergo a variety of approvals. In the interest of consistency, efficiency, and thoroughness, the Corps is investigating the use of a computer system to store the building design criteria (checking them for consistency) and then to evaluate design submittals, both in-house and out-of-house, for conformance with the published standard.

Criteria input to SEARCH from the several criteria documents mentioned above describes a list of spaces required for a particular building type (e.g., entry, office, parking lot, etc.) and specifies relationships between these spaces (e.g., adjacency, distance, visual access, enclosure, etc.). As each space or relationship is added, it is matched with all previously entered criteria, any potential conflict or duplication is

noted, and an opportunity is afforded for immediate resolution.

Evaluation of designs begins by describing drawings to SEARCH using a digital pointer. Once a proposed configuration of spaces is known, the sizes and relationships of the spaces are checked and reported. Actual area is calculated and compared with maximum and minimum requirements. A complete list of the spaces is then printed, starting with the space exhibiting the greatest error. Space-to-space relationships, such as maximum and minimum distance, adjacency, and visual access, are checked against the criteria and resulting errors are displayed.

The present implementation of the system makes use of low cost peripheral equipment, which includes two storage display units (Tektronics 4012/613) and a keyboard (Figure 1), a digital pointer (GRAFPEN)

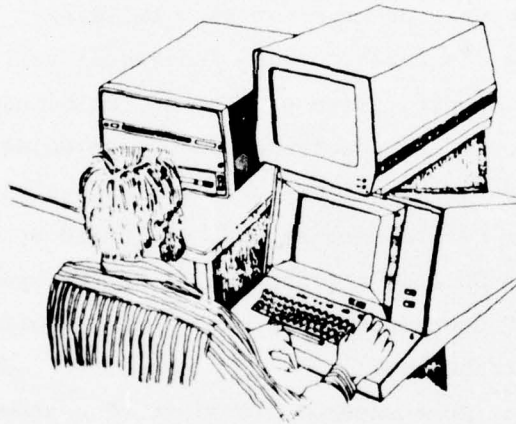

Figure 1. Storage display screens and keyboard

(Figure 2), and a hard copy unit (Tektronics 4610)(Figure 3). The software is written in the PL/1 language. SEARCH operates on the MULTICS computer at Massachusetts Institute of Technology (MIT). MULTICS, a Honeywell 6180, can be accessed interactively nationwide through the Advanced Research Projects Agency (ARPA) network (Figure 4).

Since October 1974, SEARCH has been field tested at the Office of the Chief of Engineers in Washington, D. C. OCE personnel are using the system to test the validity of several Design Guides currently under development, as well as a tool in evaluating actual building designs.

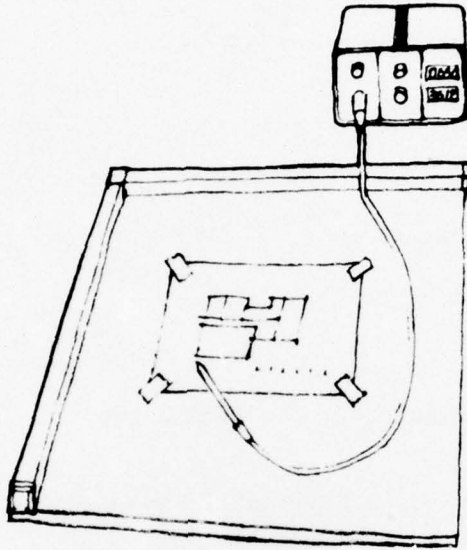

Figure 2. Digital pointer

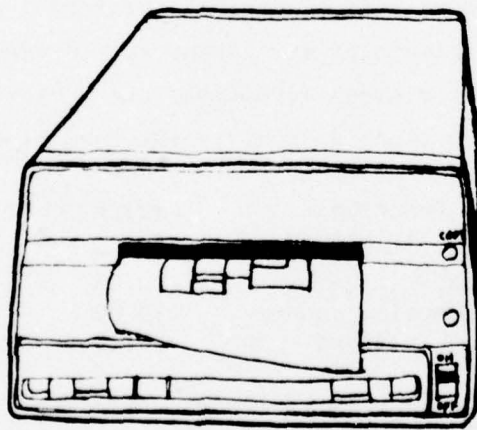

Figure 3. Hard copy (screen copier)

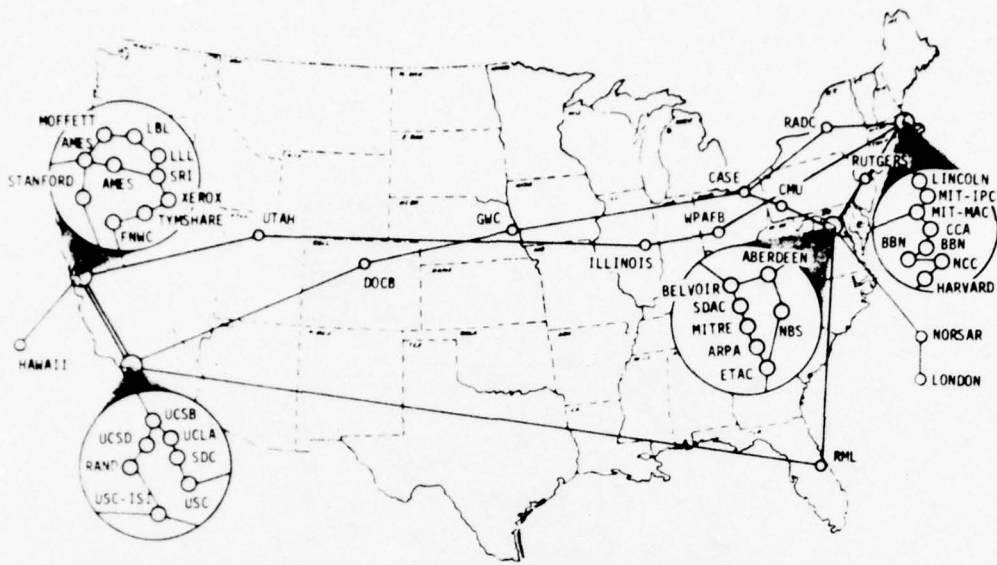

Figure 4. The ARPA network

Example: A Criminal Investigations
Division Building

This example describes a translation of design criteria into a generalized computer model, and using that model as a base, an evaluation of an architect's proposed concept design. Criteria, space requirements, and space-to-space relationships are taken from an early draft of a Design Guide for a CID (Criminal Investigations Division). Space (room) names and their area are usually found in the form of a list - for example:

<u>Functional Descriptions</u>	<u>Square Feet</u>
Lobby entrance	100.00
Reception counter	120.00
Open waiting	80.00

The commands to enter each of these spaces into the model are:

COMMAND: space

SPACE: lobby entrance 100 pg. 36

SPACE: reception counter 120 pg. 36

By typing these three "links," the first three relationships of the matrix are entered into the SEARCH model: "the lobby entrance should be adjacent to the reception counter," "the lobby entrance should be adjacent to the open waiting area," and "the reception counter should be adjacent to the open waiting area." (All three requirements are found on page 9 of the criteria document.)

Certain types of building code requirements can also be specified and checked by SEARCH. For example, we can specify that all spaces be within a certain number of feet from any fire exit.

LINK: *FrEx via near 150 pg. 10

With this single entry, all spaces (*) are required to be within 150 feet from at least one fire exit (FrEx).

Again, as with spaces, at any time a full or partial list of relationships can be printed out.

COMMAND: list relationships

```
*****
**** LIST OF RELATIONSHIPS ****
*****
```

```
SPACE ***** RELATIONSHIP ***** RELATED SPACE *** PAGE
Lobby Entrance
  adjacent to      4.00 feet of           Reception Counter    9
  adjacent to      4.00 feet of           Open Waiting         9
  nearer than     150.00 feet to         1 of Fire Exit      10
Reception Counter
  adjacent to      4.00 feet of           Open Waiting         9
  nearer than     150.00 feet to         1 of Fire Exit      10
```

Note: SEARCH deals with the following relationships between pairs of spaces:

- adjacency
- nearer than
- farther than
- visual access (must see)
- enclose

Evaluation of a proposed concept design, based on the above criteria, begins by describing the drawing to SEARCH using a digital pointer. By typing a command and pointing to two scaled horizontal points and a point that you want centered on your display screen, the drawing is set

up to be drafted (Figure 5). SEARCH then expects the name of a space (or its abbreviation) to be typed in and two points (opposite corners of the rectangular space) to be entered by the digital pointer.

COMMAND: setup 80

COMMAND: draft

DRAFT: lobby entrance

DRAFT: reception counter

DRAFT: opwt (abbreviation for open waiting)

Following this quick entering process, SEARCH compares space names, areas, and relationships against the criteria and lists out a complete evaluation (Figure 6) in response to the command "list evaluation."

The evaluation contains three sections:

- a. AREA, a listing of actual, required, and errors in floor area. Spaces are listed in order of their error, from worst to best.
- b. RANK, a ranking of spaces based on aggregate total error calculated according to the formula: Error (points) = k_1 (lineal feet) + k_2 (percent visual access) + k_3 (square feet). Where k_1 , k_2 , and k_3 are alterable program constants.
- c. LINK, a list of all space relationship errors by individual space. Spaces are listed in order of their error, from worst to best.

COMMAND: list evaluate

*** AREA OF SPACES ***

--- SPACE	----- AREA	---	REQUIRED	AREA	---	ERROR	---	PAGE
	SQ. FT.		MAX	MIN		SQ. FT.		
Open Waiting	135		80	72		55		36
Reception Counter	90		120	108		18		36
Lobby Entrance	108		100	90		8		36
.								
.								
TOTAL AREA (MAX)	7492		7245			959		

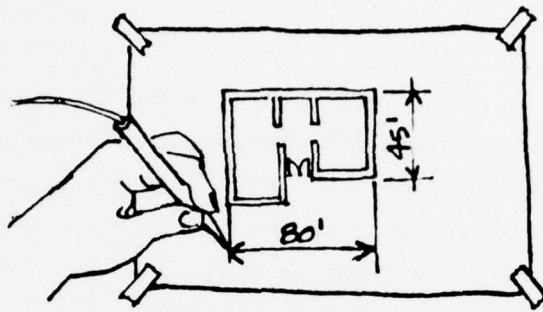

Figure 5. Doing a SETUP

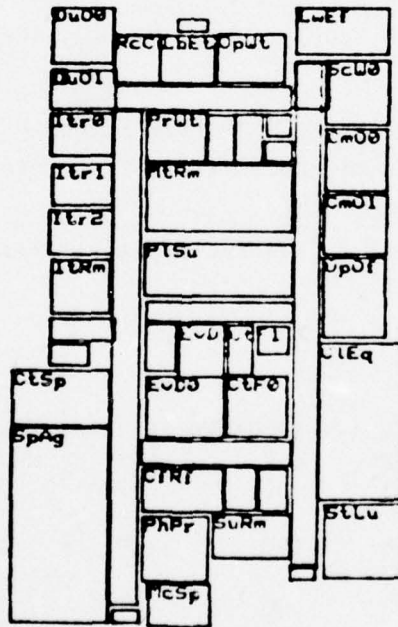

Figure 6. Computer display

*** RANKING OF WORST SPACES ***

--- SPACE ----- ERROR POINTS ---

Secretary Waiting	116
Commanders Office	18
Reception Counter	11
.	
.	
.	

---- TOTAL POINTS ---- 178

*** RELATIONSHIP ERRORS ***

Secretary Waiting connected	ERROR POINTS	116
-----------------------------	--------------	-----

--- RELATIONSHIP ----- GROUP:SPACE ----- ERROR -- PAGE --

views	100% of	Lobby Entrance	80	11
nearer than	20' to	1 of Clerical Space	26	9
nearer than	20' to	1 of Operations Office	10	9

Commanders Office connected	ERROR POINTS	18
-----------------------------	--------------	----

--- RELATIONSHIP ----- GROUP:SPACE ----- ERROR -- PAGE --

nearer than	20' to	1 of Reception Counter	10	9
nearer than	20' to	1 of Lobby Entrance	4	9
nearer than	20' to	1 of Private Waiting	4	9

Reception Counter connected	ERROR POINTS	11
-----------------------------	--------------	----

--- RELATIONSHIP ----- GROUP:SPACE ----- ERROR -- PAGE --

adjacency by	4' to	1 of Open Waiting	11	9
--------------	-------	-------------------	----	---

Future

It is planned that SEARCH will eventually be absorbed into a comprehensive computer-aided architectural design system. However, in the immediate future (next 12 months), a new expanded version of SEARCH will include the following capabilities: (a) the ability to evaluate

buildings of more than one story; (b) the ability to consider the effect of the location of doors and windows in the evaluation; (c) the ability to consider non-rectilinear spaces; (d) the ability to differentiate between "walking distance" and "mechanical distance"; (e) the ability to evaluate the use of acoustic and visual barriers; (f) the ability to evaluate "centrality" and "peripherality" of a space; and (g) the ability to measure the potential traffic through a space.

INTERACTIVE COMPUTER GRAPHICS COMES OF AGE

by

Robert L. Hall*

Interactive computer graphics can reduce the time and cost of any design process by at least one-third. In order to realize this great reduction, interactive computer graphics programs will have to be developed at every level of design. This development was not even feasible 10 yr ago; since at that time a single computer graphics device would have cost \$200,000. But today, low-cost (\$5,000 to \$15,000) graphic terminals are available, making interactive computer graphics practical for the Corps of Engineers.

Slow Development

Such low-cost terminals have been available for more than 5 yr; yet they are not being widely used in every district office. Why? Because only a few interactive graphics programs are available to the design engineer. Development has been slow because of the time spent:

- a. Learning how to use interactive computer graphics capabilities effectively.
- b. Developing subprograms that will support many application programs, such as subprograms to window and center characters and interpret commands.
- c. Developing and testing new techniques to reduce the time and cost of adding graphics to each new application.

For the past 2 yr, the Corps has been attacking those problems with the objective of making interactive computer graphics work for design engineers.

A number of advances have been made in the Computer Analysis Branch (CAB) of the ADP Center at WES and elsewhere. The projects being pursued by CAB have resulted in:

- a. A state-of-the-art study of interactive computer graphics.

* Civil Engineer, ADPC, WES.

- b. Location and evaluation of Graphics Support Software (GSS) that enables FORTRAN language programs to use the graphics features of the terminal in making plots, axes, curves, etc.
- c. Evaluation, selection, and enhancement of the Graphics Compatibility System (GCS) developed at West Point. This system provides device independent graphics capability and is easy to learn and use.
- d. Development of computer-aided grid generators to help prepare data for analysis by Finite Element Method (FEM) programs. If successful, this effort will greatly increase the usefulness of the FEM in design (see Appendix A).
- e. Development of postprocessor programs to graphically display (contours, vectors, plots, etc.) the huge amount of data produced by a FE analysis (see Appendix A).
- f. Training of engineer-programmers in interactive graphics techniques.
- g. Development of engineer-oriented, interactive graphics capability and application of it to:
 - (1) A plane frame analysis program (see Appendix B).
 - (2) A slope stability analysis program.
 - (3) A lock culvert analysis program (see Appendix B).
- h. Implementation and improvement of programs (FORTRAN subroutines) that display three-dimensional data (see Appendix C).
- i. Assistance to Corps' offices in getting approval for graphics equipment.

Results Thus Far

The results are quite encouraging. Early tests of the grid generating system show a three to one cost reduction and a seven to one time reduction. Since that time, program improvements and new features indicate cost savings will approach ten to one and time savings can be even greater.

Another test done on the plane frame program STRUPUT involved the analysis of a single loading case on a frame having twelve redundancies. Conservative estimates indicate 40 man-hours would be needed to do a moment distribution analysis by manual methods. That time was compared to the savings produced by a computer-assisted solution and an interactive graphics computer-assisted solution. They indicate:

- a. A six to one saving (time) for the computer-assisted solution.
- b. A 120 to 1 saving (time) for the graphics computer-assisted solution.

Using interactive graphics produces tangible benefits such as savings in time and money and greater ease in analyzing an engineer's problems. It also produces many intangible benefits, such as the job satisfaction of a designer working with a highly user-oriented, interactive program on a responsive computer system. We are just beginning to explore the importance of the benefits gained from a close, engineer-oriented link between the problem, the designer, and the computer.

The Future and Its Problems

Although the cost of developing good interactive graphics programs has been greatly reduced, development costs are still high. Thus the available funding must be used to produce the greatest benefits for the Corps of Engineers.

In order to accomplish these benefits the following items are essential:

- a. We must be sure we add graphics to the Corps' best programs.
- b. We must avoid duplicating efforts, especially in developing basic graphics support programs.
- c. We must maintain a Corps capability in graphics. Just as we do not want all the Corps design and analysis work farmed out to architectural engineers, so must we avoid becoming totally dependent on the high cost system of the private computer service vendors.
- d. We must identify future needs and begin working on them immediately. Otherwise, these future needs will become "Today's Project" without the best solution, thus resulting in using an old-fashioned, expensive solution to a foreseeable problem.

Recommendations

If there is a key element in the success of interactive graphics, it is close cooperation between our engineering-engineers and our engineering-computer people. Through the identification of common needs and working closely to meet local and Corps-wide needs, we will develop the computer-aided design capability that the future demands.

Appendix A: Pre- and Postprocessors for FEM Analysis

Some of the most innovative graphics work at WES has been done in support of the Finite Element Method of Analysis. This powerful method of analysis could not be used as a design tool until good pre- and post-processors were developed to prepare data and present output in graphical form. The capabilities of the pre- and postprocessor are shown in Figures 1-6 and outlined below:

I. Preprocessor:

a. Divides structure into subregions which may be aids in preparing grid networks.

- (1) Four-sided subregions for generating quadrilateral elements.
- (2) Many-sided subregions for generating either all triangular elements or quadrilateral elements with some triangles.

b. Subregion data will provide:

- (1) Sides of subregions; curved or straight.
- (2) Nodes along boundaries of subregions; equally or unequally distributed.
- (3) Subregion data will be placed in a data file to be interactively edited.

c. The four modules divisions of the program are:

- (1) Read, display, edit, and change the subregion data. When the definition is complete, the modules generate the grid.
- (2) Apply boundary condition information to the grid, such as which nodes are fixed and what are the applied forces.
- (3) Apply grid improvement features such as:
 - (a) Automatically replace adjacent triangles with quadrilaterals wherever possible.
 - (b) Smooth the grid.
 - (c) Renumber the nodes so as to minimize the grid's band width.
- (4) Display and edit the resulting grid. This includes interactively adding elements, deleting elements, moving nodes, etc.

II. Postprocessor:

a. Use the data generated from an analysis (FEM) program as input.

b. Plot any out variable calculated for nodes or elements by:

- (1) Plotting the value at its location (element centroid on node).
- (2) Drawing a vector proportional to the value at its location.
- (3) Contours of a variable at stated intervals.
- (4) Plotting the displaced grid (structures problems).
- (5) Isometric plot of the grid.
- (6) Perspective plot of the grid.

c. Draws outline of grid for each plot.

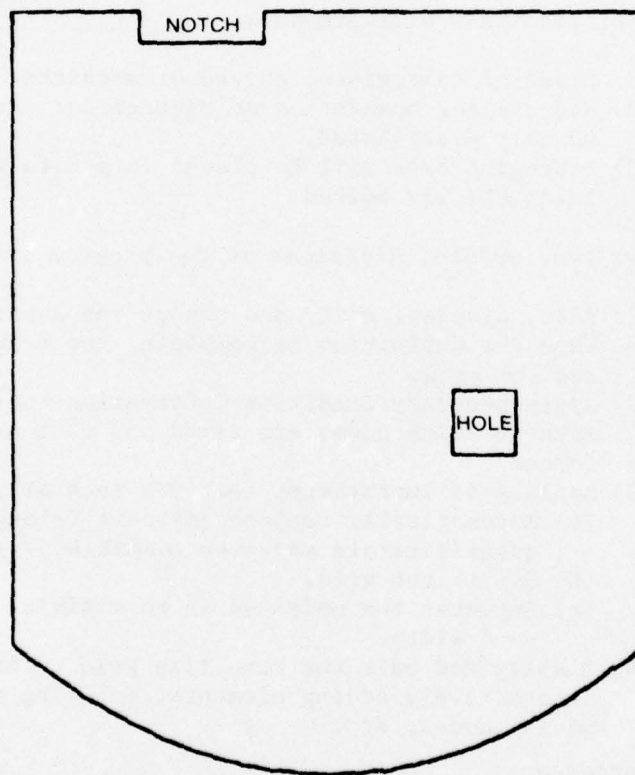

Figure 1. Geometry of problem to be gridded

XL = -12.000000
YL = -124.800000
XR = 112.000000
YU = 4.300000

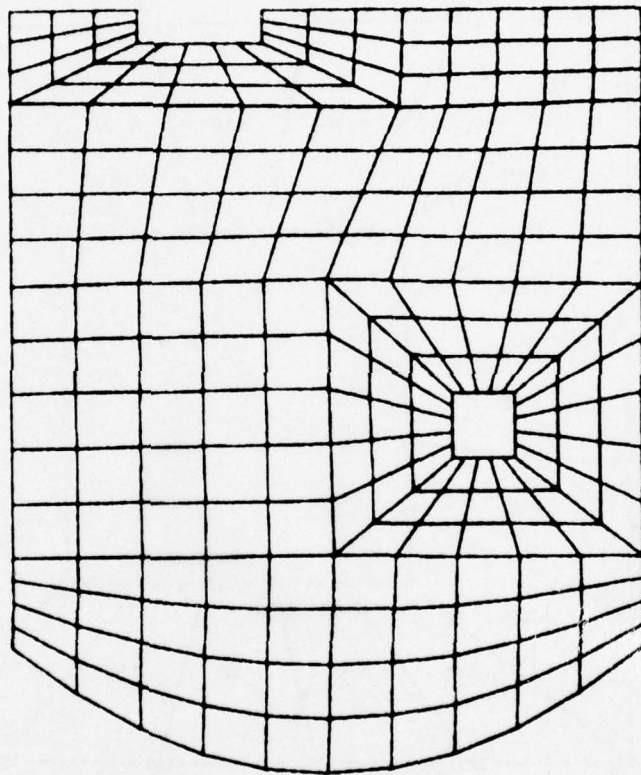

Figure 2. FEM grid of problem

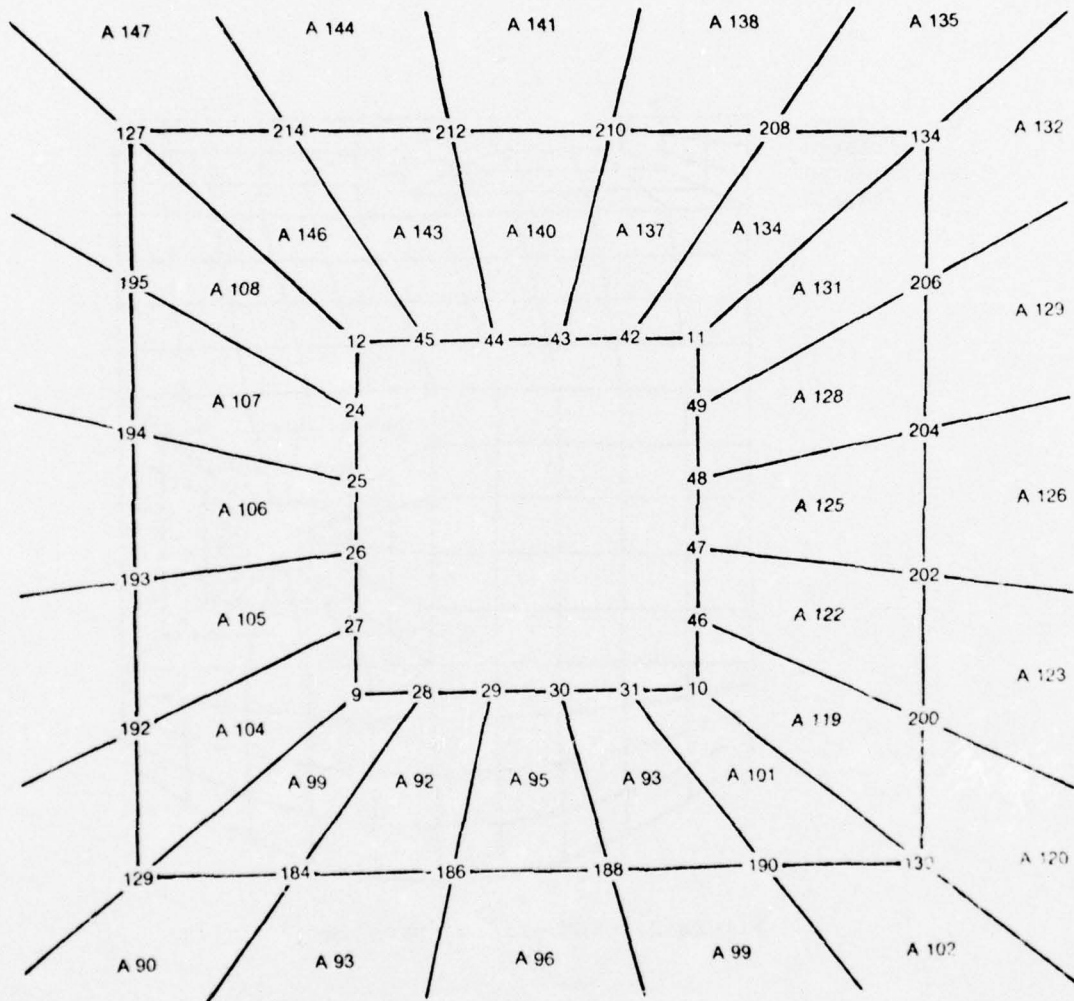
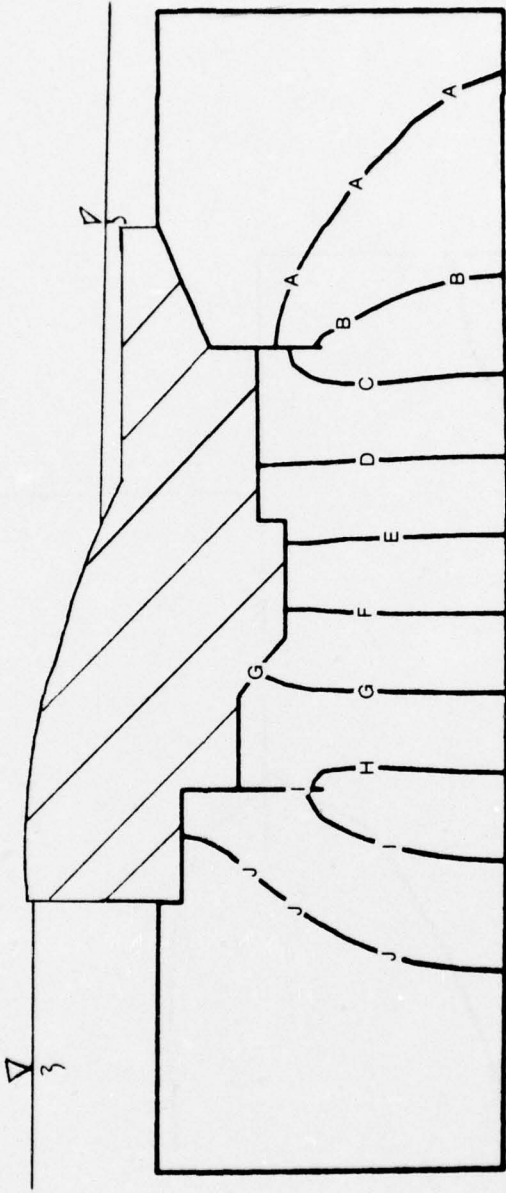

Figure 3. Window of FEM grid



XMIN = 0.
 YMIN = 0.
 XMAX = 0.2585E 03
 YMAX = 0.7500E 02

A = 0.7667E 02
 B = 0.7796E 02
 C = 0.7926E 02
 D = 0.8056E 02
 E = 0.8185E 02

F = 0.8315E 02
 G = 0.8444E 02
 H = 0.8574E 02
 I = 0.8704E 02
 J = 0.8833E 02

Figure 4. Contour of equipotentials from FEM seepage analysis

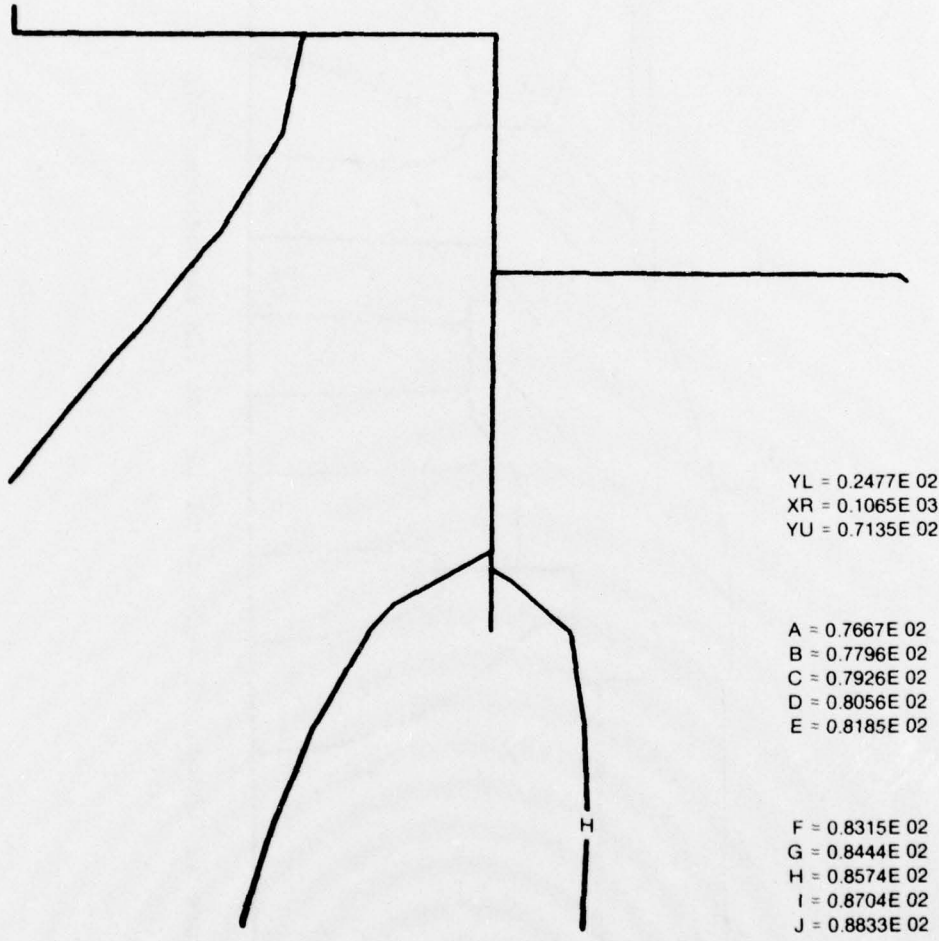

Figure 5. Window of contours

YL = 0.2477E 02
XR = 0.1065E 03
YU = 0.7135E 02

ONE ARROW INCH = 0.6368E 03 UNITS

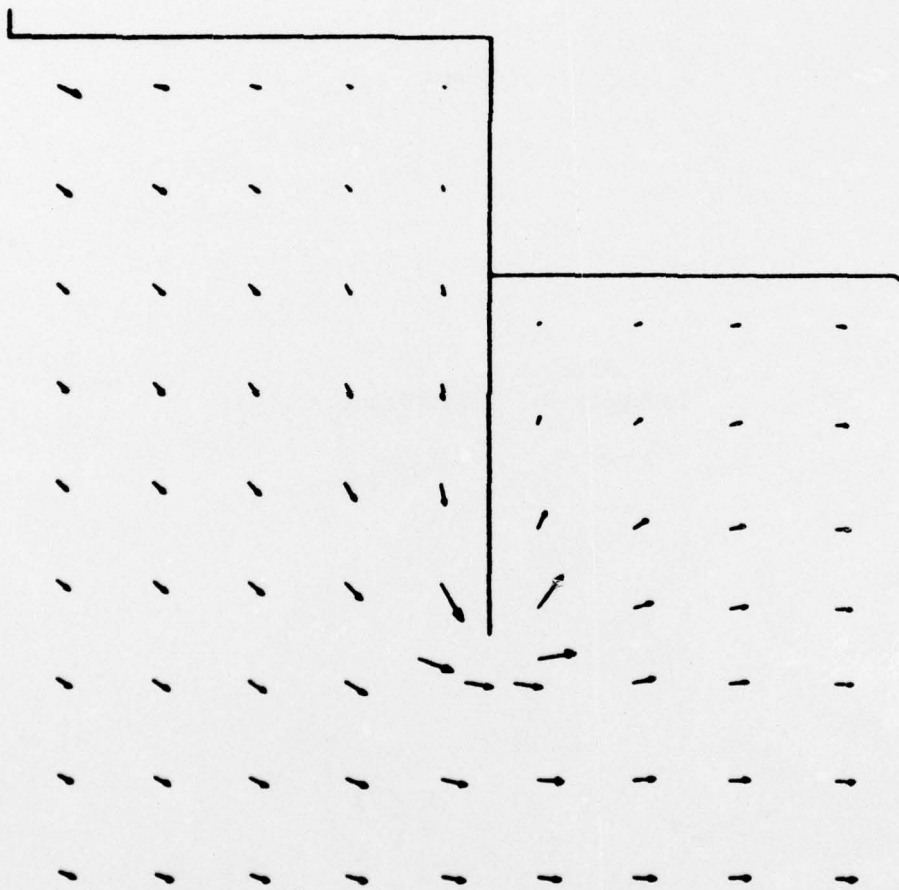

Figure 6. Vector plot of flows from FEM analysis

Appendix B: Rigid Frame Analysis

The other graphical programs developed at WES have been in support of existing analysis programs. The first such graphical program is STRUPUT which supports the plane frame analysis program GFRAME (written by Bob Brittain of the Memphis District). STRUPUT allows the user to interactively enter (via the display tube) the joints and members or prepare a data file that defines them. If mistakes have been made in the frame data, several commands are available to edit the data before the analysis. The loads are entered by way of interactive commands shown in Figure 1. Each load is displayed as soon as it is entered. STRUPUT will handle frames with 60 members and 40 joints with as many as 20 loading cases. Each joint may be loaded with a point force as well as a joint moment. Each member may be loaded with a distributed load as well as four point loads. After the frame and the loads are defined, the analyses program analyzes each load case (by the moment stiffness method) and displays the moment shear and displacement diagrams (see Figures 2-4). The programs also allow the user to re-define the member properties and add new load cases after each analysis. This allows the engineer to quickly determine the critical loading condition and make adjustments to the frame so that the critical loading case will be satisfactorily supported.

Lock Culvert Analysis

Figure 5 shows the display of the input for a lock culvert analysis. This program provides detailed instructions on how to enter the data but only when improper commands are given. This frees the frequent user from unnecessary prompting, while allowing the infrequent user to run the program without reviewing written documentation. The lock culvert data are analyzed by using the moment distribution method. The output of moment and shears may be displayed as a diagram and/or listed in tables.

MOMENT DIAGRAM

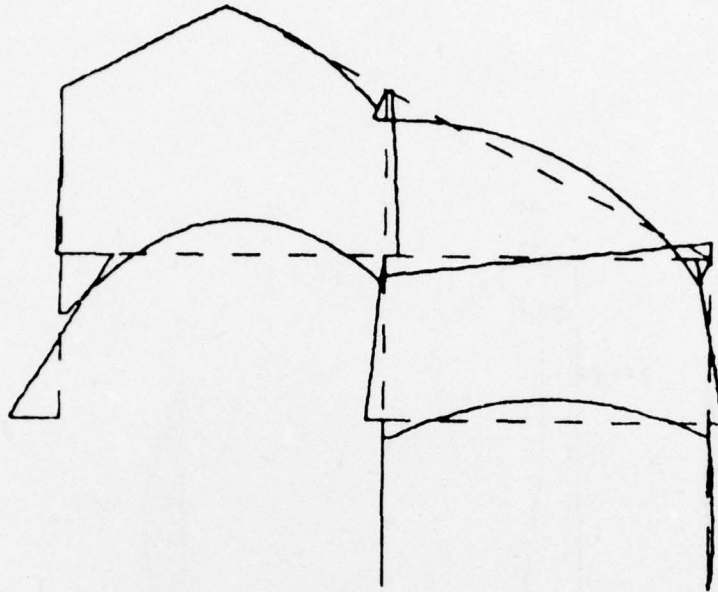

SCALE FACTOR = (1 IN. = 205 KIPS-FT)

Figure 3. Moment diagram

DEFORMED SHAPE

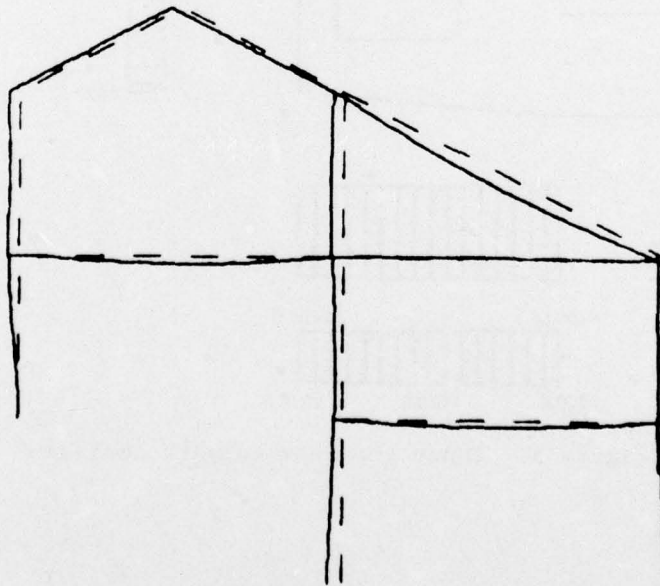

SCALE FACTOR = (1 IN. = 205 FT DISPLACED)

Figure 4. Displacement diagram

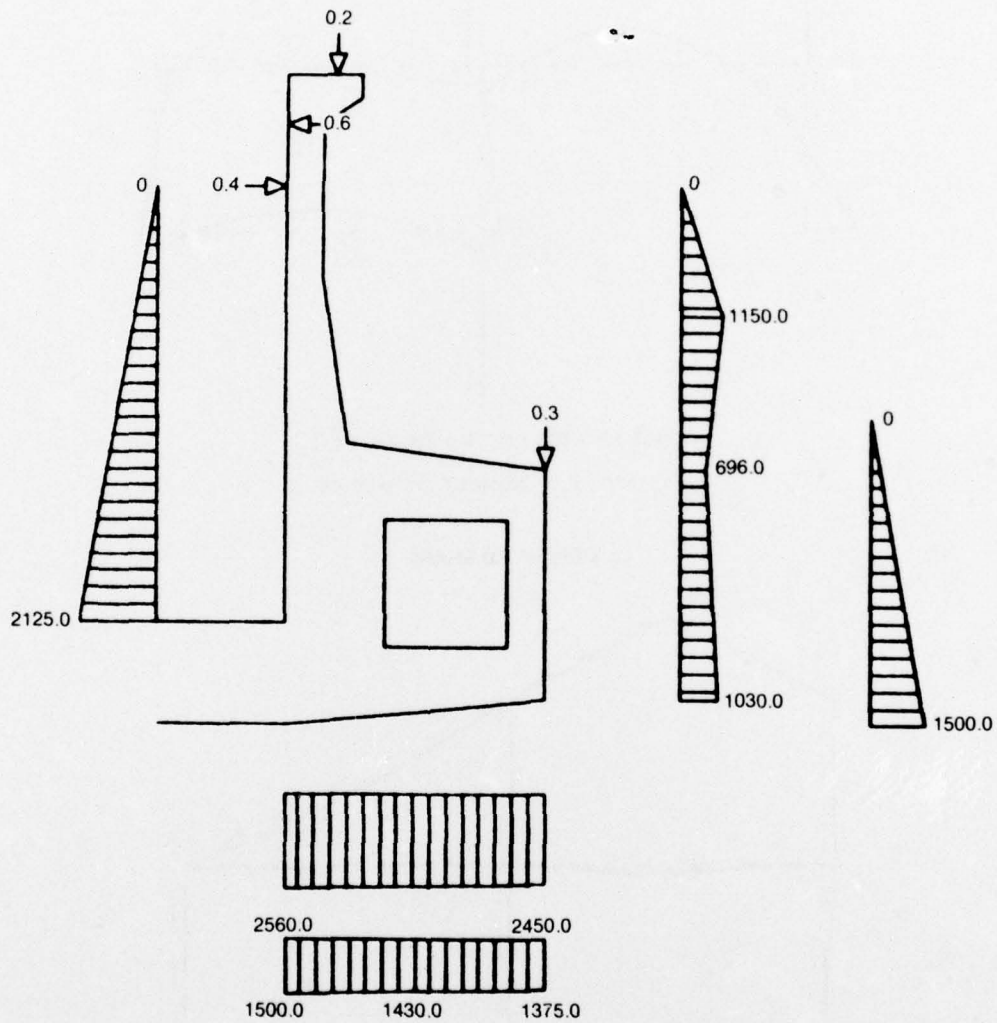

Figure 5. Input for lock culvert analysis

Appendix C: Display of Three-Dimensional Data

Several Corps applications need the display of three-dimensional data. A prerequisite to display such data is the development of a number of subprograms that can remove hidden lines, rotate a geometry in space, and be able to window specific portions of the data. These capabilities are demonstrated in Figures 1 and 2. The subroutines to display these figures come from the Lawrence Livermore Laboratories. Based on these capabilities, programs that require the display of three-dimensional data, such as in FEM, will be developed in the future.

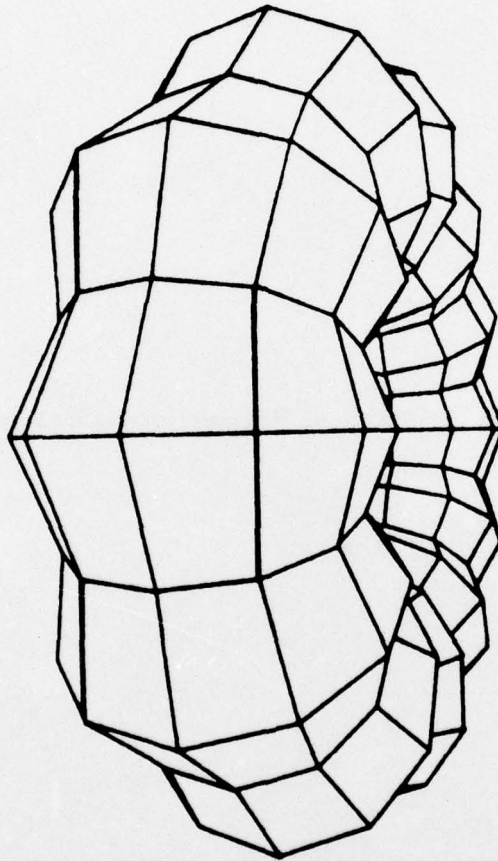

Figure 1. Display of Torus
with hidden lines removed

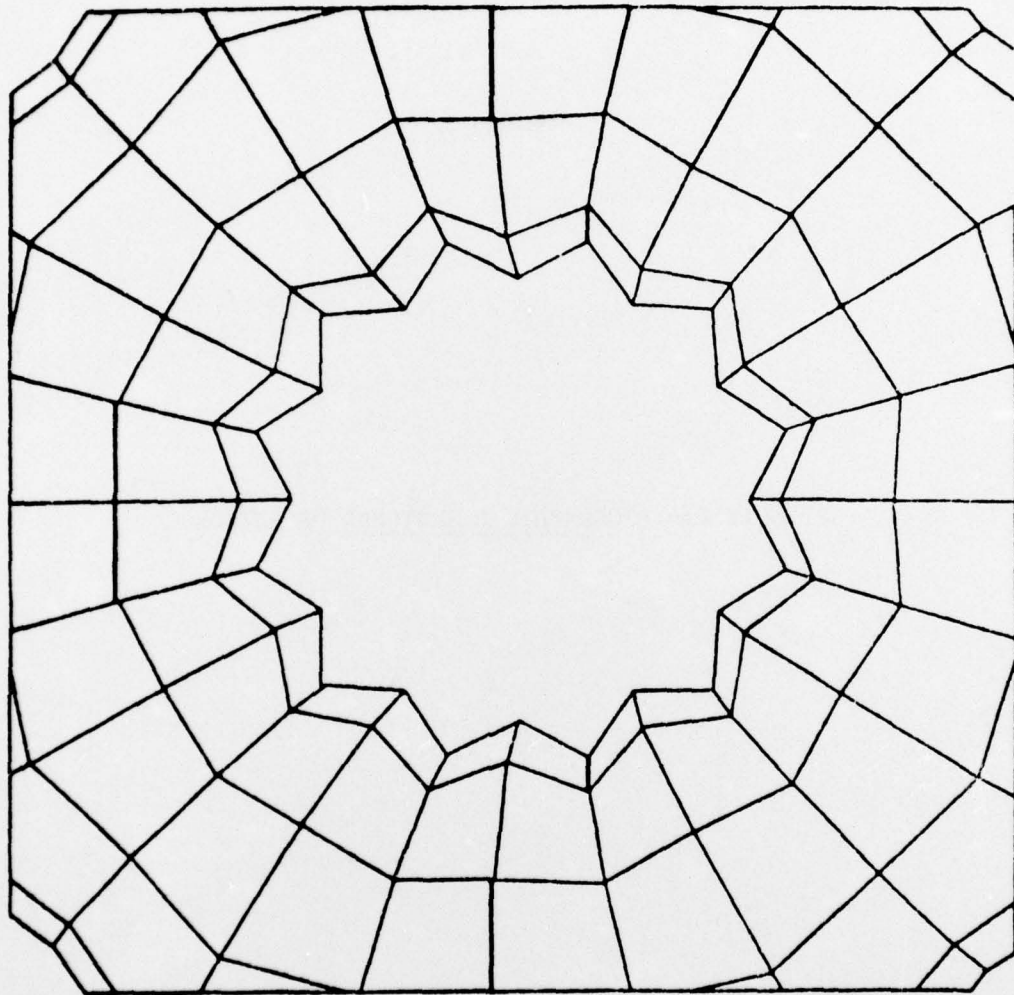

Figure 2. Window of Torus

APPENDIX A: BIOGRAPHICAL SKETCHES OF AUTHORS

Mr. Wayne Jones has a B.S. degree in Aeronautical Engineering and his M.S. degree in Engineering Mechanics from the University of Alabama. He has been working with the Computer Analysis Branch, Automatic Data Processing Center, WES, since 1972. Mr. Jones has varied experience in the use of the finite element method in soils, structures, soil-structure interaction, and 3-D problems. He has participated in short computer courses taught at WES.

Mr. Dale A. Bryant earned a B.A. in Architecture from the University of Washington in 1968, an M.A. in the same field in 1969, and is a Doctor of Architecture Candidate. He has Professional Registration in Wisconsin as an architect, has worked as a designer/draftsman, an instructor and research assistant at the University of Michigan, a consultant for the Building Research Advisory Board, an instructor and ADP analyst for the Engineer School at Ft. Belvoir, and as a research architect and Acting Chief, Master Planning & Systems Building Branch for CERL. He is presently serving as Asst. Manager, Automated Architectural and Architectural Design System Project at CERL. His recent publications are "GRAPHIC: The Student Experience," Proceedings of the Kentucky Workshop on Computer Application to Environmental Design; "SEARCH: Systematic Evaluation and Review of Criteria for Habitability," CERL Report D-43; "The Structure of SEARCH II, CERL Letter Report D-55.

Mr. Robert Bruce Dains earned a B.A. in Music Education from the University of Tulsa in 1966 and an M.A. in the same field in 1967. After a year teaching public school music and a supervisory position in a Tulsa company he returned to school, earning a B.S. in Environmental Design from the University of Oklahoma in 1971 and a Masters in Architecture in 1973. He has Professional Registration as an Architect in Wisconsin, and is presently employed by CERL as an Associate Investigator, Computer-Aided Architect Design Work Unit. He coauthored two SEARCH reports mentioned in Mr. Bryant's biography, as well as coauthoring with Mr. Bryant the Users Manual for SEARCH. He has also written An Evaluation of Computer-Aided Architectural Systems, CERL, ARC*ARC, An Architectural Design Simulation - ERDA IV, Development of the Housing Model - NSA, and Computer Application in Design Language of Environmental Space for Perspective Plotting.

Mrs. Janet H. Spoonamore, a coauthor on the SEARCH publications, graduated from the University of Illinois in 1967 with a B.S. in Mathematics Education and earned her M.S. in Mathematics there in 1968. She has worked as a systems analyst, a research programmer, and an operations research analyst, her present job with CERL. In addition to the SEARCH publications, she wrote, while working as a research programmer at the Center for Advanced Computation, University of Illinois, The CAC Economic and Manpower Model: Documentation and Users Guide, An Illiac IV Code for Solving Systems of Linear Equations, and Econometric Simulations for Using a Stochastic Model.

Mr. Robert L. Hall has a B.S. degree in Civil Engineering from Auburn University and has completed his course work for an M.S. degree in Civil Engineering from the Mississippi State University. He has been working with the Computer Analysis Branch, Automatic Data Processing Center, WES, since 1972. Mr. Hall has varied experience in the use of Interactive Graphics, structures analysis, and slope stability. He has participated in short computer courses taught at WES.

In accordance with ER 70-2-3, paragraph 6c(1)(b), dated 15 February 1973, a facsimile catalog card in Library of Congress format is reproduced below.

Corps-Wide Conference on Computer-Aided Design in Structural Engineering, New Orleans, La., 1975.

[Proceedings ... held in New Orleans, Louisiana, 22-26 September 1975; Vicksburg, Miss., Automatic Data Processing Center, U. S. Army Engineer Waterways Experiment Station, 1976-

12 v. illus. 27 cm.

Contents.-v.1. Management report.-v.2. List of computer programs for CADSE.-v.3. Invited speeches and technical presentations.-v.4. Division presentations.-v.5. State-of-the-Corps-Art (SOCA) reports on gravity monoliths, U-frame locks, and channels.-v.6. SOCA reports on gates, stoplogs, and trashracks.-v.7. SOCA reports on single- and multiple-cell conduits and tunnels.-v.8. SOCA reports on pile foundations and sheet pile cells.-v.9. SOCA reports on sheet pile walls and T-walls.-v.10. SOCA reports on stiffness methods, frames, and military construction.-v.11. SOCA reports on earthquake and dynamic analyses.-v.12. Interactive graphics, SEARCH and CORPS systems.

(Continued on next card)

Corps-Wide Conference on Computer-Aided Design in Structural Engineering, New Orleans, La., 1975.

[Proceedings ...] 1976-

(Card 2)

1. Computer-aided design -- Congresses. 2. Design -- Congresses. 3. Structural engineering -- Congresses.
I. U. S. Army. Corps of Engineers. II. U. S. Waterways Experiment Station, Vicksburg, Miss.
TA641.C67 1975