

AD-A031 310

COAST GUARD RESEARCH AND DEVELOPMENT CENTER GROTON CONN F/G 13/10
DEVELOPMENT, TEST AND EVALUATION OF AN EXPLOSIVE EMBEDMENT ANCH--ETC(U)
JUN 76 D L MOTHERWAY

UNCLASSIFIED

CGR/DC-13/76

USCG-D-98-76

NL

1 of 1
ADA031310

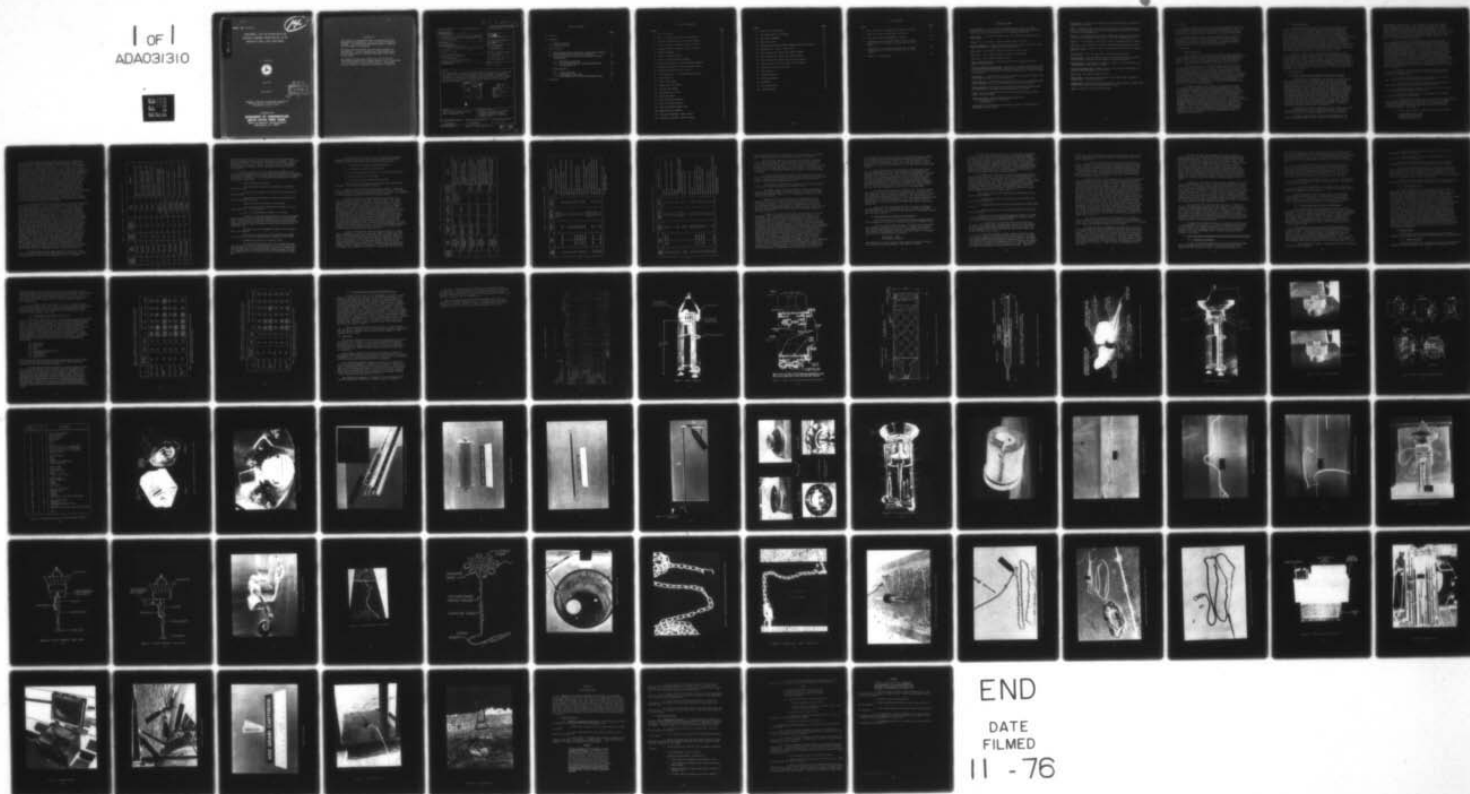

END
DATE
FILMED
11 -76

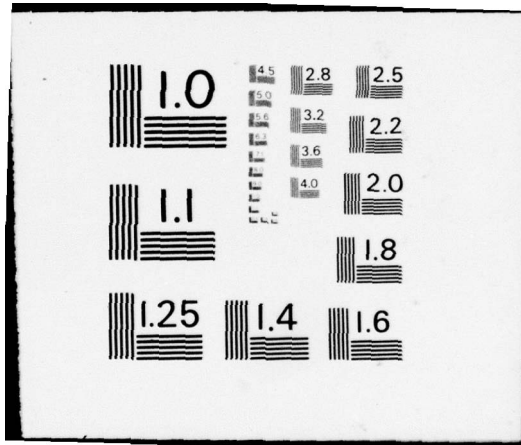

AD A031310

Report No. CG-D-98-76

14

DEVELOPMENT, TEST AND EVALUATION OF AN
EXPLOSIVE EMBEDMENT ANCHOR FOR USE IN THE
MOORING OF SMALL COAST GUARD BUOYS

D. L. Motherway



June 1976

Final Report

DDC
RECEIVED
OCT 28 1976
RECEIVED

AV

D

Document is available to the public through the
National Technical Information Service,
Springfield, Virginia 22161

Prepared for
DEPARTMENT OF TRANSPORTATION
UNITED STATES COAST GUARD
Office of Research and Development
Washington, D.C. 20590

NOTICE

This document is disseminated under the sponsorship of the Department of Transportation in the interest of information exchange. The United States Government assumes no liability for its contents or use thereof.

The United States Government does not endorse products or manufacturers. Trade or manufacturers' names appear herein solely because they are considered essential to the object of this report.

The contents of this report reflect the views of the U.S. Coast Guard Research and Development Center, which is responsible for the facts and accuracy of data presented. This report does not constitute a standard, specification or regulation.

9 Final rept. Jun 70 - Jun 76,

Technical Report Documentation Page

1. Report No. 18 19 16 CG-D-98-76	2. Government Accession No.	3. Recipient's Catalog No.	
4. Title and Subtitle 6 DEVELOPMENT, TEST AND EVALUATION OF AN EXPLOSIVE EMBEDMENT ANCHOR FOR USE IN THE MOORING OF SMALL COAST GUARD BUOYS		5. Report Date 11 June 76	6. Performing Organization Code
7. Author(s) 10 D. L. MOTHERWAY	8. Performing Organization Report No. 14 CGRADC-13/76		10. Work Unit No. (TRAIS) 762512C.01
9. Performing Organization Name and Address U. S. Coast Guard Research and Development Center Avery Point Groton, CT 06340		11. Contract or Grant No.	
12. Sponsoring Agency Name and Address Department of Transportation U. S. Coast Guard Office of Research and Development Washington, DC 20590		13. Type of Report and Period Covered FINAL REPORT June 1970 - June 1976	
15. Supplementary Notes		14. Sponsoring Agency Code	
16. Abstract This report examines an explosive embedment anchor with regard to its application as a mooring device for small Coast Guard buoys in sheltered or semi-exposed environments. It traces the development of this EEA (explosive embedment anchor) system from its inception to its ultimate disposition with regard to Coast Guard usage and provides the basis for documenting in summary form all Coast Guard efforts on the system.			
17. Key Words Anchors, marine anchors, moorings, buoys, navigational buoys		18. Distribution Statement Document is available to the public through the National Technical Information Service, Springfield, Virginia 22161	
19. Security Classif. (of this report) UNCLASSIFIED	20. Security Classif. (of this page) UNCLASSIFIED	21. No. of Pages 76	22. Price

12 76p.

ACCESSION for

HTIS White Section

DDC Buif Section

UNANNOUNCED

JUSTIFICATION.....

BY.....

INSTRUMENTATION/AVAILABILITY CODES

DATE, AVAL. NUM/OF SPECIAL

A

DDC
RECEIVED
OCT 28 1976
D

408 730

- A -

7B

TABLE OF CONTENTS

	<u>Page</u>
1.0 PURPOSE	1
2.0 BACKGROUND	1
2.1 <u>Project Evolution</u>	1
2.2 <u>Project Initiation</u>	2
3.0 APPROACH/RESULTS	2
3.1 <u>Anchor System Design, Development, Testing and Evaluation</u>	2
3.2 <u>Mooring Material Investigation and Evaluation</u>	12
3.3 <u>Shore and Shipboard Transportation Handling and Safety Considerations</u>	15
3.3.1 <u>Equipment and Handling</u>	15
3.3.2 <u>The Cartridge and Other Safety Considerations</u>	16
3.3.3 <u>In-Air Safety Test</u>	17
3.4 <u>Related Studies</u>	17
3.4.1 <u>Anchor Load Study</u>	17
3.4.2 <u>Lightweight Anchor Study</u>	18
3.4.3 <u>Risk Analysis of the Explosive Embedment Anchor</u>	21
4.0 CONCLUSIONS	21

LIST OF ILLUSTRATIONS

<u>Figure</u>	<u>Page</u>
1. Phase I gunstand.	24
2. Phase I firing mechanism design improvements.	25
3. Explosive embedment anchor cartridge schematic.	26
4. Phase I explosive embedment anchor projectile.	27
5. Improved explosive embedment anchor projectile.	28
6. Phase II gunstand.	29
7. Phase II firing mechanism.	30
8. Phase II firing mechanism schematic.	31
8a. Nomenclature; Phase II firing mechanism schematic.	32
9. Redundant hydrostatic lock (for trigger plate).	33
9a. Redundant hydrostatic lock in place.	34
10. Anchor projectile - wire rope fastening detail.	35
11. Swift load cell.	36
12. Prewitt strain gage.	37
13. Trigger plate distortion.	38
14. Reaction cone damage.	39
15. New rigid reaction cone.	40
16. Failed gun barrel.	41
17. Cable 1x19 kinked figure-8.	42
18. Cable 7x7 kinked figure-8.	43
19. Cable 3x19 kinked faking board.	44
19a. Faking board arrangement.	45
20. Can pack on gunstand - barrel inside.	46
21. Can pack on gunstand - barrel outside.	47

<u>Figure</u>	<u>Page</u>
22. Cable, 1/2" jacketed nylon.	48
23. Pre-twisted cable, 7x7 Spacelay.	49
24. Ring buoy arrangement.	50
25. Chain pack in can.	51
26. Stainless steel chain showing elongated links after firing.	52
27. Galvanized No. 4 chain - failed links	53
28. Chain mooring with "shock cord" (before firing).	54
29. Chain mooring with "shock cord" (after firing).	55
30. Chain mooring with "elastic band" (before firing).	56
31. Chain mooring with "elastic band" (after firing).	57
32. Shipping and storage containers.	58
33. Servicing rack.	59
34. Shipboard magazine.	60
35. Handling equipment.	61
36. Cartridge.	62
37. Plate penetration.	63
38. Fallen gunstand.	64

LIST OF TABLES

<u>Table</u>	<u>Page</u>
1. Table of Results - Chesapeake Bay Testing - July 1971.	5
2. Proof test of Phase II gunstand - April 1972.	8
3. Long Island buoy testing summary (2 pages).	9 & 10
4. Comparison of cyclic holding capacity (lbs) to anchor loads (lbs) due to 10-foot, 7.5-second wave and 3-knot current.	19
5. Comparison of cyclic holding capacity (lbs) to anchor loads (lbs) due to 2-foot, 3.5-second wave and 3-knot current.	20
6. Summary of risk analysis.	23

GLOSSARY OF TERMS

Anchor projectile - In the explosive embedment anchor system, the anchor projectile is a cylindrical object with four hinged flukes which extend when a strain is taken on the shank end. It is fired into the bottom.

Anchor shank - The slotted cylindrical end of the projectile which holds the serve cable.

Arming - The act of making a firing mechanism ready for firing.

Bellows diaphragm - A cup-shaped rubber device which prevents the entry of sea water into the piston chamber of the hydrostatic lock.

Cable, 3x19 - Three strands containing 19 wires in each strand.

Cable, 7x7 - Seven strands containing 7 wires in each strand.

Cable, 1x19 - One strand containing 19 wires.

Cable, jacketed 1/2" nylon - Braided nylon line with polyurethane jacket adhered to its surface.

Explosive Embedment Anchor System - Consisting of a gunstand (loaded with a 600 grain cartridge and an anchor projectile with a serve cable) which fires upon contact with ocean bottom thereby embedding the projectile to provide a mooring for small buoys.

Faking board - A board upon which a line is laid out in successive bights, each succeeding one adjacent to the preceding one.

Figure eight pack - Pack in which the turns form a series of overlapping figure eights advancing about one or two diameters of the line at each turn.

Firing mechanism - Contains the sear pin and sear which when activated drive the firing pin into the primer thereby detonating the cartridge.

Fluke - Flat end of anchor which bites into the bottom material providing surface area for holding.

Hydrostatic locks - Pressure actuated plungers which lock:

1. Firing mechanism sear lockup arm.
2. Trigger plate.

Lock-up arm - Arm connected to sear and held in place by firing mechanism hydrostatic lock until armed.

Penetrometer - A device used to penetrate the bottom material to determine its composition and density.

Phase I - This identifies the period of testing from the letting of the contract to Magnavox in April of 1971 to the conclusion in July of 1971 of buoy deployments in Chesapeake Bay.

Phase II - This identifies the period of Coast Guard testing after the conclusion of the Chesapeake Bay test in July of 1971 and continuing into 1973.

Pigtail - A short length of cable used to attach a mooring cable to an anchor.

Proof test - Test performed to evaluate performance against design criteria.

Propellant charge - Explosive used to provide the force used to fire a projectile.

Quad ring seal - Four "o" rings used to seal piston from leakage.

Reaction cone - Truncated conical shape on top of gunstand used to reduce the recoil distance resulting from the firing of an anchor projectile.

Retaining ring - Ring designed to engage the inside of the anchor flukes when the projectile is inserted in gun barrel.

Scratch type strain gage - Mechanical device which records loads placed on a system by scratching lines on a brass disc.

Serve cable - The cable attached to anchor.

Shear screws - Small set screws designed to shear when loaded providing a braking effect on the anchor cable.

Trigger plate - Horizontal flat piece attached to firing sensors or legs of gunstand which actuates the sear when gunstand is armed.

Unlay - To unravel a line, strand by strand.

1.0 PURPOSE

The scope of this report includes all pertinent development and testing of the explosive embedment anchor over the period 1968-1976 as related to the objective of developing a suitable method of anchoring small Coast Guard aids-to-navigation buoys in a sheltered or semi-exposed environment.

It includes initial testing, contract development and revisions of the system configuration, long-term testing with the identification of and attempts at solutions to the problem areas. It documents ordnance testing and classification efforts and provides conclusions with regard to the acceptability of the system for its intended use.

2.0 BACKGROUND

2.1 Project Evolution

The concept of utilizing smaller Coast Guard aids-to-navigation craft to deploy and service small aids in sheltered and semi-exposed environments dictated a need to evaluate various types of lightweight anchoring systems. This concept was one recommended as a result of a contracted study of Coast Guard aids-to-navigation operations conducted in 1970.

Prior to this concept, a limited test had been carried out on the Tombigbee-Black Warrior River in March of 1968. This test compared the performance characteristics of ten different anchoring systems and provided recommendations for further efforts. Among the more promising anchors tested was a Magnavox explosive embedment anchor system. It appeared as a result of these tests that this system would fill most of the criteria determined by the U.S. Coast Guard to be pertinent to a lightweight mooring system for small buoys. Subsequently, in 1970, a development project was initiated to study the applicability of the explosive embedment anchor system to the Coast Guard requirements.

The Magnavox Company had conducted an independent, in-house development program starting in 1962 which demonstrated the feasibility of the explosive embedment anchor for particular applications. During 1963 and 1964, a feasibility study and demonstration program was conducted for development of the self-embedment anchor; and in 1966, subsequent to the development of the system, ocean field tests were conducted. In 1967-68, the system was further refined, and it was with this system that the Tombigbee-Black Warrior River test was carried out. In 1970, an explosive embedment penetrometer system was developed for the U.S. Army Mobility Equipment Research and Development Center (hereinafter referred to as USAMERDC). This system was designed to evaluate bottom composition/soil strength by firing a small penetrometer into the bottom and recording extraction loads. This data was then used to approximate the holding power which could be obtained from a much larger explosive anchor embedded in the same bottom.

2.2 Project Initiation

A proposal to design and develop an explosive embedment anchor system was solicited from the Magnavox Corporation by the Coast Guard in 1971. A contract was awarded to Magnavox (hereinafter referred to as the Contractor) in May of 1971, and Phase I of the program was begun. The Phase I part of the program called for delivery of a USAMERDC style gunstand modified for the Coast Guard application and Phase I anchor projectiles which were longer with more fluke area than those used in the USAMERDC system. The tests were conducted with the Phase I gunstand in Chesapeake Bay off Little Creek, Virginia, in July of 1971 to determine additional modifications to the gunstand and anchor designs which were to be incorporated into the final, or Phase II, explosive embedment anchor system. Another significant aspect of the Phase I testing was to evolve a system for handling the gunstand and anchors during the actual deployment of buoys.

By April of 1972, the prototype Phase II gunstand was ready for testing with all modifications complete. Proof testing was conducted at the Contractor's Urbana, Illinois, test facility. Several minor modifications were made as a result of this testing. The completion and delivery to the Coast Guard of this modified hardware represents the point of departure beyond which the Coast Guard conducted its independent test and evaluation of the system. The details of this phase of the program as well as pertinent information on the development of the system are covered in the remaining sections of this report.

3.0 APPROACH/RESULTS

3.1 Anchor System Design, Development, Testing and Evaluation

As mentioned in the background, the Contractor had been involved since 1962 with the explosive embedment anchor concept and technique. Their work had evolved to a point where they had a prototype gunstand and early design four- and two-fluked anchors which were used for the Tombigbee-Black Warrior River test. They had been successful in embedding anchors into ocean bottoms at water depths up to 13,680 feet in deep ocean testing during 1964. These expendable "Scarab" anchors had been designed for a minimum holding power of 200 pounds in sand. Additional refinement and testing in 1966 was successful with six buoys deployed off Bermuda in depths ranging from 3,150 feet to 10,500 feet. Two buoys were found off station and retrieved. Examination showed that the cartridges had not fired in the anchor system due to failure of the primers. This was later traced to human error in assembling the cartridge. The mooring tensions in the buoys deployed ranged from approximately 100 pounds to 240 pounds depending on ocean current conditions.

During 1968, 15 buoys were deployed in depths ranging from 5,520 feet to 13,680 feet off St. Croix, Virgin Islands. All 15 buoys were successfully anchored for periods ranging up to 120 days on station.

The Coast Guard made the first practical application of the explosive embedment anchor in March of 1968 in a test program on the

Tombigbee-Black Warrior Rivers. This test was a comparison of "Scarab" self-embedment anchors (two- and four-fluked) with eight other types of anchors. Despite some problems with the firing apparatus, the "Scarab" anchor exhibited the highest holding-power-to-weight ratio of all the other types of anchors in all types of material encountered. It was concluded at that time that the concept of an explosive embedment anchor for small buoys was practical, but a great amount of development would have to be done to provide a reliable mooring system.

In June of 1970, the USAMERDC awarded a short-term contract to the Magnavox Corporation for an explosive embedment penetrometer system. The penetrometer was a small explosive embedment anchor which was fired into the sub-bottom and extracted. Bottom penetration was measured using a footage counter on the anchor line from the winch. The force required to extract the penetrometer registers on a dial gage of the tensiometer. This information was used to predict the expected holding power of a series of large explosive embedment anchors. This system was delivered to the Army in the fall of 1970, and further development work was conducted on it in the spring of 1971. A modified version of this gunstand with anchor projectiles which were designed for the Coast Guard application were ordered and delivered under contract in July 1971. This system is referred to as the Phase I Explosive Embedment Anchor. The general design modifications made to improve performance, reliability and equipment life were as follows. (Refer to Figure 1.)

- a. Length of gunstand legs was increased 6 inches to provide sufficient acceleration room for anchor projectile prior to making contact with the bottom material.
- b. A second stiffening support ring was added to the tripod legs to help prevent the muzzle blast from bending them.
- c. The lifting yoke was made stronger to prevent bending when high loads were applied to the mooring line through the gun.
- d. Tapped holes were provided in the top plate of the gunstand to allow mounting an experimental reaction cone.
- e. The entire head assembly of the gunstand was strengthened to better withstand the firing forces.
- f. The diameter of the hydrostatic lock within the firing mechanism was increased to reduce static friction. This was done to allow arming to take place in shallower water. The stroke of the hydrostatic lock piston was lengthened and an indicator added to allow visual evidence of the safe position. (See Figure 2.)
- g. The cartridge (Figure 3) propellant charge was as follows:
 - 30 grains Hercules No. 2400
 - 500 grains Hercules HPC 87
 - 70 grains Dupont IMR 3031

In July of 1971, the Coast Guard joined with the USAMERDC and the Contractor in conducting penetration and holding power tests of the Coast Guard Phase I explosive embedment anchor projectile. (See Figure 4.) These tests were conducted in Chesapeake Bay off Little Creek, Virginia. Ten firings were conducted with this Phase I system using a 25-foot motor surf boat as the test platform. Because of the test craft hull configuration, relatively calm water was required to take accurate tensiometer readings of the loads required to extract anchors from the bottom as well as accurate measurement of the penetration into the bottom. When the first three anchors were fired, the anchor flukes were bent in against the shank and would not open when the anchor was extracted. Spacers to hold the flukes out from the projectile body and also to stiffen the fluke itself were welded to the inside of each fluke. Upon additional firings, the tips of the flukes then bent in. To solve this problem during the test the flukes were reduced in length from 8 inches to 6 1/4 inches. However, the fluke material proved to be too soft and continued fluke failures occurred. The results of this testing are summarized in Table 1. Additionally, the shear pin securing the cable to the gunstand failed in four cases. At that time the gunstand was retrieved by a second cable attached to it, and the shear pin on the anchor cable was a safety feature to prevent loss of the gunstand. Subsequent improvements in deployment and retrieval techniques eliminated the need for this method.

As a result of this test, numerous changes in the anchor projectile were made. (See Figure 5.) This modified anchor projectile was tested at the Contractor's test facility in October 1971. In these tests an anchor was hand driven into a test pit (sandy clay bottom) to depths of six, eight and thirteen feet respectively. The anchor was then pulled back in the respective tests to 22, 25 and 27 inches before a 500-pound load was achieved to indicate the flukes were fully open. The peak loads were 1,050, 1,330 and 1,540 pounds respectively. The anchor was inspected after each test, and no damage was detected. When the flukes were removed to inspect the hinge pins, one pin was found broken near the center of the hinge, having failed in tension. This pin was replaced and the anchor was fired into the test pit with about 18 feet of water above the bottom. The propellant load was reduced to 390 grains from the normal 600 grain load to reduce penetration and allow recovery of the anchor. The purpose of this firing was to determine if the new hinges would prevent fluke damage during penetration. The anchor penetrated to a depth of four feet. It was then pulled back 22 inches to a load of 750 pounds to insure the opening of the flukes fully. The anchor was then loaded to 1,800 pounds and allowed to sit for 16 hours, after which time the load reading was 1,720 pounds. A 3x4-foot piece of plywood buried in the pit had been pierced by the anchor when fired. This was partially dug out, and the anchor loaded to 1,500 pounds. This load was concentrated on the tip of one fluke against the plywood during the extraction process. The hinge pin sheared, causing that fluke to fall off. The remaining hinge pins and the other flukes were undamaged, showing no signs of deformation.

Two anchors with the new fluke design were tested by the Coast Guard in November of 1971 in the Potomac River near Fort Belvoir, Virginia, in conjunction with similar testing being conducted by the USAMERDC.

Table 1. Table of Results - Chesapeake Bay Testing - July 1971.

TEST FIRING NUMBER	TYPE BOTTOM	BORING SITE NUMBER	ANCHOR PENETRATION (FEET)	LOAD (LBS)	COMMENTS
1	Clay/Silt	3	19	300-420	Flukes bent against shank, did not open
2	Clay/Silt	3	20	250-375	Tip of flukes trimmed; flukes bent against shank, did not open
3	Clay/Silt	3	18	225-350	Tip of flukes trimmed; flukes bent against shank, did not open
4	Soft Silt	10	27	No Load	Equipped with spacers; bent flukes did not open
5	Soft Silt	10	28	1200 MAX Dropped to 730	Flukes bent downward at hinge; trimmed to 6 1/4" with spacers
6	Soft Silt	10	27	1100 MAX Dropped to 475-600	Flukes bent downward; trimmed
7	Silt/Sand	6	9	1330-1410 3 FT extraction	Shear pin broke at 1510 LBS
8	Silt/Sand	6	12	1450-1580 3 FT extraction	Shear pin broke at 1580 LBS
9	Hard Silt/Sand	4	12	860-1000 1 FT extraction	Shear pin broke at 1300-1450 LBS
10	Hard Silt/Sand	4	13	600-740 1 FT extraction	Shear pin broke at 1300-1450 LBS; 3 FT extraction

The first anchor was fired in an area believed to have a stony bottom. The serve cable was severed, and the anchor was not recovered. The second anchor was fired into a soft bottom. The flukes were keyed by pulling back two feet on the cable. The load increased to about 1,500 pounds, and the shear pin connection failed, preventing recovery and inspection of the anchor.

A further result of the joint testing with USAMERDC in July of 1971 was the incorporation of several more modifications to the gunstand and associated equipment. The resultant gunstand and equipment are identified as the Phase II EEA system. The more significant changes and the reasons for them are listed below:

a. Phase II gunstand (Figure 6).

The lifting frame or yoke was lengthened to accommodate the reaction cone.

An elastic cord assembly for tie down of the second cable pack was added.

The reaction cone was added to reduce the gunstand recoil when the cartridge was fired.

Brackets to hold the reaction cone were added.

The frame structure was modified and extended to hold the second cable pack in proper position.

b. Phase II firing mechanism (Figures 7, 8 and 8a).

The Phase I firing mechanism hydrostatic lock was redesigned using a flexible long stroke bellows diaphragm to replace the quad ring seal. This reduced even further the static friction to increase reliability of safe arming and re-safing in shallow water as well as preventing contaminants and sea water from being in contact with the base of the hydrostatic lock.

The lock-up arm was redesigned to adapt to the new hydrostatic lock assembly.

The flat nut on top of the firing mechanism was changed to a 1 1/2-inch hex nut for tightening with a standard socket wrench.

c. Redundant hydrostatic lock (Figures 9, 9a)

The redundant hydrostatic lock for the trigger plate was also redesigned to use a bellows diaphragm in lieu of the O-ring seal. This lock has a detent which, when in place, restricts the upward motion of the trigger plate. At arming depth the detent depresses, allowing the trigger plate to come in contact with the firing mechanism trigger arm.

In April of 1972, the final version of the Coast Guard Phase II gunstand (as described above) was proof tested at Magnavox's Danville, Illinois, facility. The purpose of this testing was as follows:

- a. To check out the gunstand design modifications.
- b. To evaluate the reaction cone function.
- c. To review the new anchor design - new flukes, hinge and pins.
- d. To test various serve cable types.
- e. To test the revised firing mechanism design.

A total of five test firings were completed using the 600-grain cartridge. The results are tabulated in Table 2.

Starting in May of 1972, the Coast Guard conducted a long-range testing program in Long Island Sound using the Phase II system. The purpose of this testing was to gain information on mooring loads and on the acceptability of various mooring materials for use with the anchor system.

During the first day of buoy deployments the moorings of two out of three anchors fired parted when a load was applied. The second anchor functioned properly. There were three set screws in the anchor shank which protrude into the cable slot. When the anchor is fired, the end of the cable is free to move about ten inches in the slot stopping when the button swaged on the cable end reaches the set screws. (See Figure 10.) The slot is filled with a white butyl caulking material which is intended to reduce the impact loading of the swaged end button on the set screw material. This is accomplished through energy absorption in the displacement of the caulking by the button during its travel through the slot. The stainless steel set screws were sheared off by the force of the end button impacting against them. Cadmium-plated, mild steel set screws were procured and used thereafter; however, occasional set screw failures continued to occur. Provision for two additional set screws was made in the anchor shank in order to retain the cable/swaged termination. Thereafter the set screws held in all cases, but several instances then occurred where the swaged fitting parted the cable.

A total of 32 buoys were deployed during the Phase II testing. Table 3 summarizes the locations, buoy type, cable, cartridge load, water depth, bottom penetration, cable above bottom and total cable length as well as some of the problems encountered during the testing. During the course of deployment of these buoys, one buoy was equipped with in-line load measuring devices for four different periods. The first period, between 18 October and 11 December 1972, 1,500-pound capacity Swift self-recording load cell (Figure 11) was placed in the mooring configuration. The maximum load recorded was 120 pounds. A second load cell of the same

Table 2. Proof test of Phase II gunstand - April 1972.

TEST FIRING NUMBER	CABLE TYPE	DEPLOYMENT METHOD	WATER DEPTH	ANCHOR PENETRATION	EXTRACTION DISTANCE	MAXIMUM VERTICAL DISTANCE	COMMENTS
1	.200" dia. armored (steel & alum.) ACCO	Lowered by hand slowly	18 FT	10 FT 2 IN	21" (No added extraction after 400 LB reached)	1,900 LB No creep	Nicks on one leg; scratches on rear leg; reaction cone cover bent in due to hydrodynamic pressure
2	1/4" polypropylene coated spacelay MACWHYTE	Lowered by hand slowly	30 FT	Unknown	-	-	Serve cable pulled out of cylindrical swage fitting; reaction cone cover dished in further
3	1/4" polypropylene coated spacelay MACWHYTE	Lowered by hand slowly	34 FT	8 FT 0 IN	0	2,000 LB No creep	Reaction cone cover dished in further; spun base also dished in 2 places; no cracks only appearance is affected
4	.200" dia. armored (steel & alum.) ACCO	Free Fall	41 FT 6 IN	5 FT 9 IN	0	1,900 LB No creep	Cable scratches on gun barrel and legs (.005 to .010" dp.); bottom of spun cone dished in further but top cover in concave shape which will support hydrodynamic forces
5	.200" dia. armored (steel & alum.) ACCO	Free Fall	27 FT	9 FT 0 IN	24"	1,900 LB	No further dishing of reaction cone; no other visible damage

Table 3. Long Island buoy testing summary (2 pages).

BUOY NUMBER	CABLE TYPE	CARTRIDGE LOAD	PENETRATION DEPTH (FT)	DAYS ON STATION	PROBABLE FAILURE MODE*
-			Unknown		Stainless Steel Set Screws Connect
-			Unknown		Cable to Anchor Sheared
A1	1x19 Armored	600	14.3	208	Cable Parted 59'3" From Buoy During Storm
A2			14.5	287	Cable Parted 19'4" From Buoy
A3			16	380	Cable Parted 33'2" From Buoy During Storm
A4		600	15.8	241	Missing
A5		500	12.5	187	Cable Parted 15'1" From Buoy During Storm
A6	1x19 Armored	600	15	<321	Missing
A7	7x7 Jacketed	600	18	173	Counterweight Unthreaded From Buoy
A8	7x7 Jacketed	500	15.5	39	Counterweight Unthreaded From Buoy
A9	1x19 Armored	600	18	<380	Missing
A10	1x19 Armored	600	17	208	Cable Parted 28'8" From Buoy During Storm
-			Unknown		Cable Pulled Out of Gunstand When
-			Unknown		Boat Drifted in Too Strong Current
A12	1x19 Armored	600	15.5	50	Cable Parted 20'3" From Buoy During Service
A16			Unknown	39	Cable Parted 13'5" From Buoy During Storm
A17			16.3	50	Cable Parted 18'1" From Buoy During Service
A18	1x19 Armored	600	10.5	47	Missing

*All Deployments Had 70' of Cable From Buoy to Anchor

Table 3 (continued). Long Island buoy testing summary.

BUOY NUMBER	CABLE TYPE	CARTRIDGE LOAD	PENETRATION DEPTH (FT)	DAYS ON STATION	PROBABLE FAILURE MODE*
A8	7x7 Jacketed	500	14.4	27	Missing
A11	1x19 Armored	600	<22.2	37	Cable Parted 60'6" From Buoy in Kinked Arc
A12			<27.7	27	Missing
A13			20.9	<22	Cable Parted 49'4" From Buoy in Kinked Arc
A14			<27.2	41	Missing
A17		600	18.0	<75	Missing
-			Unknown	-	Cable Pulled Out of Gunstand, Too Strong
A19		500	18.9	40	Current In Deep Water & Deep Penetration
A20		600	18.1	41	Cable Parted 67'8" From Buoy
B1		600	10.2	35	Cable Parted 59'5" From Buoy
B5		500	12.0	<63	Missing
B6	1x19 Armored	600	12.2	34	Cable Parted 43'6" From Buoy
B7	7x7 Jacketed	600	8.9	63	Counterweight Unthreaded From Buoy
B8	7x7 Jacketed	500	11.0	<28	Counterweight Unthreaded From Buoy
B9	1x19 Armored	600	3.4	14	Anchor Damaged During Embedment
B10			10.7	35	Missing
B14			16.7	23	Cable Parted 33'5" From Buoy
B15			8.7	23	Cable Parted 60'8" From Buoy
B16	1x19 Armored	600	11.2	20	Unknown, Buoy Recovered Without Cable or Shackle

*All Deployments Had 70' of Cable From Buoy to Anchor

type was placed on the buoy on 11 December 1972 and recovered on 26 January 1973. During this period the maximum load recorded was 90 pounds.

From 26 January 1973 to 13 February 1973, a Prewitt mechanical scratch type strain gauge of 1,500-pound capacity (Figure 12) was placed on the same buoy with a peak load of 460 pounds being recorded and an average of 85 pounds over the period. On 13 February this gauge was replaced with another of the same type; and, when it was removed on 21 March 1973, it had recorded a 375-pound peak load with an average of 140 pounds through the period.

No further readings were attempted at this time due to the high rate of cable failure and resultant risk associated with the loss of recording devices. Insufficient data was collected to draw any conclusions with respect to average expected mooring line loads.

Some additional equipment and functional problems were encountered during the buoy deployments which are described below:

The primary problem during this period of testing was wholesale failure of the mooring cables. This necessitated a program of cable and other mooring material evaluation, which is addressed in detail in a later section of this report.

During one firing the hydrostatic lock jammed and would not return to the fully safe position. The bellows seal was replaced and performance was improved. The mechanism was returned to the Contractor for evaluation, and the internal groove of the hydrostatic lock base in which the bellows diaphragm was seated was found to allow too much clearance. This was corrected, and the mechanism functioned as designed, arming at approximately ten feet.

A number of situations occurred where the gun did not fire after deployment. These malfunctions can be described in two separate cases. In the first case, after following the prescribed safety features, the unit was brought back to the surface and held there to inspect it for the probable cause of malfunction. It was noted that the firing mechanism hydrostatic lock had functioned in that the trigger arm had been displaced partially by the normal upward movement of the trigger plate. This represented a condition where the constraint provided by the firing mechanism hydrostatic lock had been removed by normal functioning of that lock but where the trigger had been displaced only partially and was in a balanced position where slight additional movement would cause the cocked spring to release and actuate the firing pin. Inspection also showed that the redundant hydrostatic lock (mounted on gunstand) was in place. (See Figure 9a.) A boat pole was used to carefully push the trigger arm down to the pre-displaced position prior to bringing the gunstand on board. Further inspection on board revealed that distortion had occurred between the trigger plate and the firing leg (Figure 13) which moves the trigger plate against the trigger arm of the firing mechanism. The trigger plate itself was found to be distorted when a straightedge was laid across its flat surface.

It was obvious from the inspection that the repeated acceleration loadings of the trigger plate during firings had weakened the base material to the point where distortion had taken place. This distortion in turn was the cause for the malfunction and was later corrected; however, it was found that the condition would continue to recur after one or two additional firings.

In the second case it was observed that the hydrostatic locks had functioned properly and the firing mechanism had actuated with no cartridge detonation resulting. Upon retrieval of the gunstand and careful removal of the cartridge, it was placed in the storage magazine. Later inspection of the cartridge showed that the firing pin had contacted it but that the firing pin impression on the primer was reduced compared to the same impression on the primers of cartridges previously detonated. Subsequent measurement of a new firing pin against the used one revealed that the used pin was worn down .013 inches from the free length of the new one. This was determined to be the cause of the malfunction.

One other problem involved the reaction cone. The thin aluminum cover began to tear at the corner of an opening for the lifting handle. The polyurethane foam in the chamber adjacent to this tear began to crumble. The firings were completed using the torn cone. The cone was replaced with 1/16-inch sheet aluminum stock and a less rigid foam than that previously used (Figure 14). Buckling continued to occur, and a rigid, non-foam-filled reaction cone was successfully developed and used as a replacement (Figure 15).

One gun barrel failed toward the end of the Long Island Sound testing (Figure 16). It is estimated that the total number of firings with this barrel was approximately 100 (the Contractor's recommended replacement life of the barrel).

3.2 Mooring Material Investigation and Evaluation

This section deals with the mooring system and related problems which developed in the course of evaluating the explosive embedment anchor.

Of the 32 firings where buoys were attached to the mooring cable none remained on station more than 13 months. Of those buoys accounted for, 16 sustained mooring cable failure, 1 anchor shank failed, and 4 buoys failed. The remainder of the buoys were never found. Two different cable types were employed during this period:

1x19 armored - ACCO
7x7 jacketed - MacWhyte

The examination of those cables recovered showed two groups of failures, each of which showed cable kinking. (See Figures 17 and 18.)

The first five failures occurred 39 to 50 days after deployment of buoys. Three of these buoys were recovered, and examination showed the failure in two cases to be in the area where the cable was attached to a cleat while the buoy was being attached to the cable prior to launching. The combination of small cleat radius and stress placed on the cable by the boat mooring load put permanent kinks in the cable. Four additional cable failures appeared to result from the same cause, although much less severe, as indicated by longer time to failure. To preclude further cable damage in future deployments, the cleat was replaced by a bollard with an 8 1/2-inch diameter (39 times the cable diameter).

The second group of failures occurred on buoys deployed after the bollard was installed. This type of failure occurred primarily within 15 feet of the anchor. Sample failed cables sent to the manufacturer revealed failure of up to 12 strands of the 19 total strands to have occurred in the torsional fatigue mode. Thus, it was concluded that the natural torsional unlaying of the cable from hockling during the firing process, succeeded by repeated buoy loadings, was causing the cable to fail in an area where it previously had kinked. This area primarily is in that portion embedded in the bottom or just above it.

Three possible causes were identified for consideration as the reason for the kinking.

- a. Kinking as the cable is accelerated out of the cable pack due to the muzzle velocity.
- b. Kinking might occur by the cable striking the gunstand during firing.
- c. Kinking might occur under deceleration when the cable piles up on the bottom.

During 1973 and 1974 various approaches were pursued to attempt to solve the problems of cable kinking and subsequent torsional failure. The principal ones explored are discussed below.

- a. A "plywood pack" faking board (Figures 19 and 19a) used in place of the figure-eight pack gave better results with less kinking. By using a more flexible 3x19 jacketed cable, even better results were shown, although contact with the gunstand and hard ground removed some of the jacketing from the cable.
- b. A test was conducted in which a 29-foot section of cable was fixed to a crane at its upper end with a weight equal to 10 percent of its rated breaking strength suspended from its lower end. The weight was rotated several times, building up a torsional stress in the cable, the weight was restricted from unwinding and the cable/weight was lowered to the ground, relaxing the cable and causing it to coil. Upon lifting the weight from the ground, permanent kinds were formed. This test

showed that a 3x19 torque balanced construction offered the best resistance to unlaying and a greater resistance to kinking than a 1x19 or 7x7 strand construction.

c. A total of 30 additional test firings were made in this period. Failures of the various mooring materials prevented the accumulation of long-term holding power data. Testing was conducted on three coated cable types: MacWhyte 3x19 Nilspin, MacWhyte 7x7 Spacelay, and 1/2-inch jacketed nylon. Test emphasis was directed toward obtaining a mooring material and/or mooring material packing process which would greatly alleviate, if not eliminate, the severe cable kinking problems which had hampered progress to date.

During this period of the evaluation, two of the three gunstand legs were removed so that an aluminum "can" with the mooring material wound inside could be tested. Figure 20 shows the gunstand with "can" in place with the gun barrel through its center. Nine firings were made with this setup using the 3x19 Nilspin and the 1/2-inch jacketed nylon attached to anchor projectiles with the flukes removed for easy retrieval. The cable jackets of both types were damaged in several areas and kinks were formed in the steel cable. The jacket damage was believed to be caused by the cable protruding through the gap in the can so a piece of aluminum was fitted across the opening. Subsequent firings showed jacket damage as well as kinking in the steel cable. An examination of the gun barrel revealed markings as though the cables were being drawn around the barrel, possibly forming kinks. The can was placed on the outside of the barrel (Figure 21). Several test firings were conducted with this arrangement using 3x19 Nilspin and 7x7 Spacelay cables. Jacket damage and kinking still occurred. The cables were spirally wound in the cans in a counter-clockwise direction starting at the top edge and bringing the end out through the slit in the side at the bottom. The cable was held in the can by the use of 3M Industrial Adhesive #847 applied to the inside wall of the can.

The 1/2-inch jacketed nylon line (Figure 22) was affixed to an anchor without flukes by means of a short "pigtail" of 1x19 armored cable. This system worked well without kinking, but the mass of the jacketed nylon reduced the penetration capability of the anchor.

In order to reduce the kinking of the steel cable, a test was run in which 1x19 ACCO cable and MacWhyte 7x7 Spacelay cables were wound on a mandrel putting a reverse twist in the cable for each turn on the mandrel. The cables were slid off the mandrel and into the aluminum can. The kinks were greatly reduced but were still considered unsatisfactory. (See Figure 23.) A third cable was wound on a ring buoy with a 20-foot lead between the gunstand and the ring buoy. This cable showed no kinks, but the cable parted due to the high inertial load imposed by the cable and ring buoy on the anchor. Figure 24 shows the arrangement used for this test.

Two types of chain were evaluated at this time. These were 1/8-inch proof coil #316 stainless steel and #4 straight link proof coil galvanized machine chain. The chain was coiled in the aluminum cans and held in place by #20 soft copper wire at six equi-distant points. (See Figure 25.) Several test firings were made of each type. A short "pigtail" of cable was attached to an anchor without flukes for easy recovery. These tests were successful with only a slight elongation of links on the stainless steel chain and one bent thimble on the galvanized steel chain. Several attempts to set buoys with the stainless steel chain met with failure due to parted links or the "pigtail" from the anchor parting (Figure 26). The galvanized #4 straight link proof coil machine chain (Figure 27) was used with partial success. One buoy was set, and in other attempts the "pigtail" failed as in the case with the stainless steel chain.

Attempts were then made to reduce the impact loading on the chain links which was causing them to fail. Two different concepts were used to achieve this. In one case, a small diameter nylon cord (3/16 to 1/4 inch) was rove through the individual chain links and secured at each end of the chain (Figure 28). The length of cord used (10 ft.) was less than the length of chain it was used on (12 ft.). The effect of this cord was to provide a "spring" in the chain as well as provide a cushion between the individual links, thus reducing the link-to-link impact loads by absorbing energy in elongation of the nylon cord. This method was generally found to be successful in that the cords elongated and parted in some cases (Figure 29) resulting in reduced incidence of chain elongation and failure.

One other method was used where the free length of chain was reduced by "compressing" each individual link relative to one another and potting this reduced chain length in a liquid rubber (G.E. RTV 100) which later cured to an elastic state (Figure 30). An example of the result would be a 12-foot free length of chain which can be "compressed" to 9 feet. Once potted in the rubber it becomes effectively an elastic band which can elongate three feet before the individual chain links come into contact with each other. Tests with this method proved successful in practically eliminating any effects on the chain material.

Although these methods would indicate a potentially effective way to achieve success with a mooring for use with the explosive anchor system, it is misleading. The addition of the mass to the chain (particularly in the case of the rubber compound) tended to greatly increase the inertial loading on the serve cable/swaged button connection causing persistent failures at that point.

3.3 Shore and Shipboard Transportation Handling and Safety Considerations

3.3.1 Equipment and Handling

In order to facilitate handling of the explosive embedment anchor system, carrying cases were provided to transport the elements of the system from shore storage to a vessel. These consisted (Figure 32) of

a propellant cartridge box, anchor projectile and cable pack box, reaction cone box and a gunstand box (with a removable servicing rack)(Figure 33) for use on deployment vessel. A shipboard magazine which holds one propellant cartridge box with 15 cartridges was utilized during deployment (Figure 34). The actual deployment procedure developed as a result of the testing follows:

a. The boat was headed into the wind and current ahead of the buoy site, and the boat's anchor was dropped. The boat was allowed to drift back to the site and a strain taken on the boat's anchor line. (In earlier testing the gunstand was lowered and the boat secured to the anchor cable after the anchor projectile had been fired. This led to pre-loading of the anchor prior to securing the buoy. It also caused some cable kinking when a small cleat was used to secure the cable.)

b. The gunstand was lowered by hand to one-half to three-quarters of the depth, held until it was properly oriented vertically, then allowed to free fall to the bottom.

c. Upon firing, the gunstand is recovered by hand, requiring a minimum of three men to haul it up. The retrieval of the gunstand required three men to manhandle it aboard safely.

Handling equipment installed aboard the test boat consisted of an electro-hydraulic crane with a lifting capacity of 1,000 pounds, a winch capable of a 3,000-pound pull at a rate of 30 feet per minute, a stern roller mounted on the transom and a bollard with 8-inch diameter posts located just forward of the stern roller. (See Figure 35.)

3.3.2 The Cartridge and Other Safety Considerations

The cartridge (Figure 36) was assigned a Class "B" classification (Appendix B) by the Bureau of Explosives of the Association of American Railroads. A Class "B" powder-actuated device must be stowed and transported according to the Code of Federal Regulations, Title 29, Section 1919.109. This section requires storage in a Class II magazine. Transporting of the cartridge over the road would have to be only on designated roads and could not be through populated areas. The vehicle would have to be marked with the words "Explosive B" on both sides and the driver must be 21 years of age or older.

Six cartridges were vibration tested at Inland Laboratories in Chicago, Illinois, according to Aberdeen Proving Grounds Material Test Procedure 4-2-804. Two were vibrated at room temperature, two at 145°F and two at -50°F. One of those vibrated at room temperature failed to fire on the first try although the firing pin indented the primer. A second firing attempt of the same cartridge failed also. All of the others fired properly when tested on the Contractor's test range. The results were compared with the firing pressure of non-vibrated cartridges as follows:

a. Room temperature vibration - Same peak pressure as non-vibrated. One misfire with no results.

b. +145°F temperature vibration - Reduced by 1,000 psi from non-vibrated pressure of 47,000 psi.

c. -50°F temperature vibration - Reduced by 2,000 psi from non-vibrated pressure of 47,000 psi.

The conclusion drawn from this testing was that the vibration and temperature variation did affect the performance of the cartridge.

The loss in pressure in the 145°F test could be attributed to reduced friction between the propellant particles allowing increased impact forces. The 50°F test showed a larger effect on performance. It could be speculated that the cold temperature caused condensation of water vapor inside of the cartridge wetting the propellant and primer plus some degradation due to the vibration caused a lowered peak pressure.

Appendix A contains detailed safety instructions and precautions which must be observed in the handling and operation of the EEA system.

3.3.3 In-Air Safety Test

In order to evaluate what could happen in the event that the gunstand was fired accidentally on board a deploying vessel, a test was conducted at Naval Underwater Systems Center, Newport, Rhode Island, in August of 1975. The gunstand was positioned above a 1/4-inch 6061 T6 aluminum plate (representing an extremely conservative aluminum hull thickness) in a stand which supported but did not restrain it. The safety locks were removed, and a mechanical triggering device installed in order to fire the gun from a remote position 50 feet away. Two tests were performed in order to observe the safety hazards inherent in an accidental firing. In the first test, the anchor projectile cleanly pierced the 1/4-inch plate (Figures 37 and 38) then travelled a distance of 40 inches to the ground and penetrated the hard packed clay-gravel earth a distance of 21 inches. The gunstand rose 9 feet in the air, turned 180° and landed on the reaction cone about ten feet from the test stand. In the second test the projectile passed cleanly through the plate and penetrated the earth a distance of 18 inches. The gunstand rose approximately 11 feet, did a 360° turn and landed on the firing leg about ten feet from the test stand. In both cases the mooring cable payed out freely and remained attached to the projectile. Still pictures were taken of each test (Figure 38) to aid in evaluating quantitatively the effects of an accidental in-air firing of the gunstand.

3.4 Related Studies

This section reviews three studies pertinent to the explosive embedment anchor program and the effect generated in light of their conclusions.

3.4.1 Anchor Load Study

An analytical anchor load study performed by the Civil Engineering Laboratory, NCBC, Port Hueneme, CA, to determine the capability of the

explosive embedment anchor to withstand various loadings imposed by Coast Guard buoys subjected to prescribed wave and current conditions. Specifically, the study examined loading under maximum design current with 10- and 2-foot waves. Performance in that maximum (10-foot) wave with 3-knot current and a normal wave (2 feet) with a 3-knot current are shown in Tables 4 and 5 respectively.

The results of this study showed the explosive embedment anchor to appear to be a useful device for mooring some Coast Guard aid-to-navigation buoys, especially the sixth class standard and lightweight plastic types. Other buoys may be moored in the conditions noted providing the bottoms consist of coarse sands or stiff clays.

3.4.2 Lightweight Anchor Study (Reference a)

This study, conducted by the U.S. Coast Guard Research and Development Center in 1975, was of great significance to the explosive embedment anchor project. It examined the replacement of concrete sinkers with other anchor types to reduce the cost of operating the system of small navigational buoys. Sets of requirements were defined that identify the anchors suitable for use in several operating systems. A ranking system was devised to give each anchor a series of scores relating to its desirability in the various situations. The highest scoring anchors were discussed in terms of their potential for improving the buoy mooring operation. The ranking system evaluation criteria used as a basis for determining suitability for an anchor for mooring the smaller classes of Coast Guard buoys are listed below:

- (1) Reliability
- (2) Performance
- (3) Safety
- (4) Cost
- (5) Installation characteristics
- (6) Transportability
- (7) Availability
- (8) Compatibility

These factors were further divided into sub-elements which further defined anchor characteristics and each was assigned a percentage value which contributed to the total value for each factor.

The conclusions reached regarding the explosive embedment anchor were that its applicability to the mooring situations described (which were determined to be those which a Coast Guard aids-to-navigation boat would encounter most frequently) was in the lowest ranked group in every case along with other high rate of energy embedment types. From these rankings it was readily apparent that other anchoring systems showed much more promise of achieving the criteria for a lightweight anchor system for small buoys. These results led to a risk analysis type study which evaluated the associated risk of continuing with the EEA program against the Coast Guard operational requirements originally set down for the anchor system.

Table 4. Comparison of cyclic holding capacity (lbs) to anchor loads (lbs) due to 10-foot, 7.5-second wave and 3-knot current.

Soil	Max. Cyclic Holding Cap. (lbs)	Depth, d (ft)	Scope Ratio	Cyclic Anchor Loads (lbs)					
				4CR	5CR	6CR	5CPR	6CPR	ROLYAN
Dense Sand	1320	15	1.5	1345	1305	505	770	205	340
		60	1.1	1190	1090	430	655	325	310
Sandy Silt	720	15	1.5	1345	1305	505	770	205	340
		60	1.1	1190	1090	430	655	325	310
Sensitive Sand	300	15	1.5	1345	1305	505	770	205	340
		60	1.1	1190	1090	430	655	325	310
Stiff Clay	2040	15	1.5	1345	1305	505	770	205	340
		60	1.1	1190	1090	430	655	325	310
Soft Clay	660	15	1.5	1345	1305	505	770	205	340
		60	1.1	1190	1090	430	655	325	310
Very Soft Clay	420	15	1.5	1345	1305	505	770	205	340
		60	1.1	1190	1090	430	655	325	310

NOTE: Circled figures represent condition where buoy mooring load exceeds the soil holding capacity.

Table 5. Comparison of cyclic holding capacity (lbs) to anchor loads (lbs) due to 2-foot, 3.5-second wave and 3-knot current.

Soil	Max. Cyclic Holding Cap. (lbs)	Depth, d (ft)	Scope Ratio	Cyclic Anchor Loads (lbs)					
				4CR	5CR	6CR	5CPR	6CPR	ROLYAN
Dense Sand	1320	6	1.5	580	585	175	310	170	110
		60	1.1	820	740	270	430	225	200
Sandy Silt	720	6	1.5	580	585	175	310	170	110
		60	1.1	820	740	270	430	225	200
Sensitive Sand	300	6	1.5	580	585	175	310	170	110
		60	1.1	820	740	270	430	225	200
Stiff Clay	2040	6	1.5	580	585	175	310	170	110
		60	1.1	820	740	270	430	225	200
Soft Clay	660	6	1.5	580	585	175	310	170	110
		60	1.1	820	740	270	430	225	200
Very Soft Clay	420	6	1.5	580	585	175	310	170	110
		60	1.1	820	740	270	430	225	200

NOTE: Circled figures represent condition where buoy mooring load exceeds the soil holding capacity.

3.4.3 Risk Analysis of the Explosive Embedment Anchor

In light of the results of the lightweight anchor study, a risk analysis of the successful completion of the explosive embedment anchor project was undertaken in the summer of 1975. The approach taken was to evaluate the anchor against other candidates for fulfilling the same requirements and assigning numerical values to whether or not a candidate has met a requirement partially, fully or not at all, as well as whether a risk was not applicable. Weighting factors were assigned to each of the evaluating criteria indicating the relative importance. This ranking is consistent with the order of importance assigned the eight anchor system rating features used in the lightweight anchor study. To develop a weighted score simply multiply the weight factors by each of the unweighted element scores and total. Dividing by the number of rating features gives a weighted average score. Comparison then of the explosive embedment anchor score and the "other candidates'" score can be made as to the relative risk associated with achieving success in satisfying the stated requirements. The results are shown in Table 6.

Upon reviewing the summary results, Table 6, it was concluded that the risk of achieving success in satisfying the operational requirements with the explosive embedment anchor system was high compared to other candidate anchor systems.

4.0 CONCLUSIONS

The explosive embedment anchor system could be developed into a useful buoy mooring tool. However, in view of the many problems encountered throughout the entire project to this point, it must be concluded that the concept was not compatible with Coast Guard operational requirements in that conducting a further extensive effort to perfect the system was not acceptable.

The principal area which has not been satisfactorily evaluated is the mooring material selection for durability, reliability and operational deployment. All materials and configurations chosen failed to be compatible with the anchor system and extended service requirements.

Other problems encountered included the failure of the hydrostatic lock in the firing mechanism to properly arm the gunstand. Coupled with this on occasion was the distortion of the trigger plate in later testing when two of the firing sensor legs were removed, and the worn firing pin which would not detonate the primer. These problems created a definite safety hazard in the retrieval of the gunstand and subsequent disarming of the firing mechanism and clearing of the bore.

The stringent requirements for transport of the cartridges created less than satisfactory conditions for everyday usage of the system.

The cost of the system was high compared to other methods as seen in reference a. The acquisition cost of gunstands, anchors and cartridges escalated rapidly during the course of the project and further testing and evaluation would be costly in terms of the risk associated with successful operation of the unit for the intended use.

There is no question that the explosive embedment anchor has the capability of holding certain buoys (e.g., 5th class and 6th class river type buoys) on station. However, it must be concluded that the financial expenditure is not worth the risk to attain that goal at this time.

Table 6. Summary of risk analysis.

LEGEND:

Assessment Risk Score
 + = Requirement met Low=L 8
 - = Requirement not met Med=M 5
 P = Requirement partially met High=H 1
 N/A = Requirement met; Risk N/A 9

OPERATIONAL REQUIREMENT	WEIGHT (1-3)	REQUIREMENT	EXPLOSIVE EMBEDMENT ANCHOR			OTHER CANDIDATES Ref: "Lightweight Anchor Study"		
			RISK IN MEETING	SCORE (UNWEIGHTED)	SCORE (WEIGHTED)	RISK IN MEETING	SCORE (UNWEIGHTED)	SCORE (WEIGHTED)
Feasibility	1	+	N/A	9	9	L	8	8
Overall Effectiveness	2	P	H	1	2	L	8	16
Capability (3 year min.) Stable Rivers Sheltered Water, Hard and Soft Bottom Mooring	3	-	H	1	3	L	8	24
Anchor Soft Bottom	3	P	M	5	15	L	8	24
Anchor Hard Bottom	3	-	H	1	3	M	5	15
Safety (Crew and Boat)	2	-	H	1	2	L	8	16
Experience Level/Training	1	+	N/A	9	9	L	8	8
Reliability	3	-	H	1	3	L	8	24
Maintainability	2	-	H	1	2	L	8	16
Transportability Degree of Regulation	1	-	H	1	1	L	8	8
Shore Based Handling	1	P	H	1	1	M	5	5
Deployment	2	+	N/A	9	18	M	5	10
Cost	2	-	H	1	2	L	8	16
		UNWEIGHTED	TOTAL	41	70		95	190
		UNWEIGHTED	AVG	3.2			7.3	
		WEIGHTED	AVG		5.4			14.6

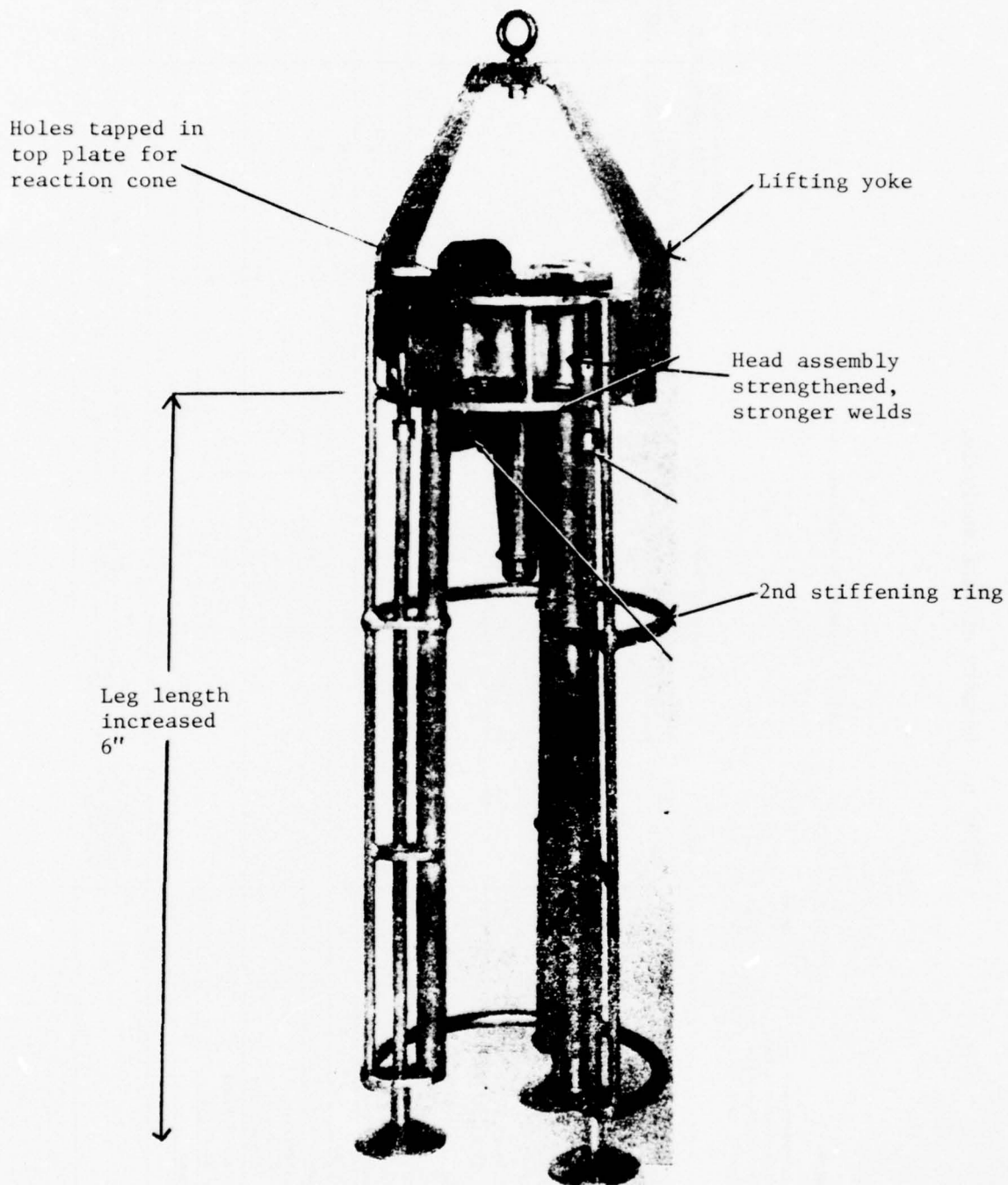
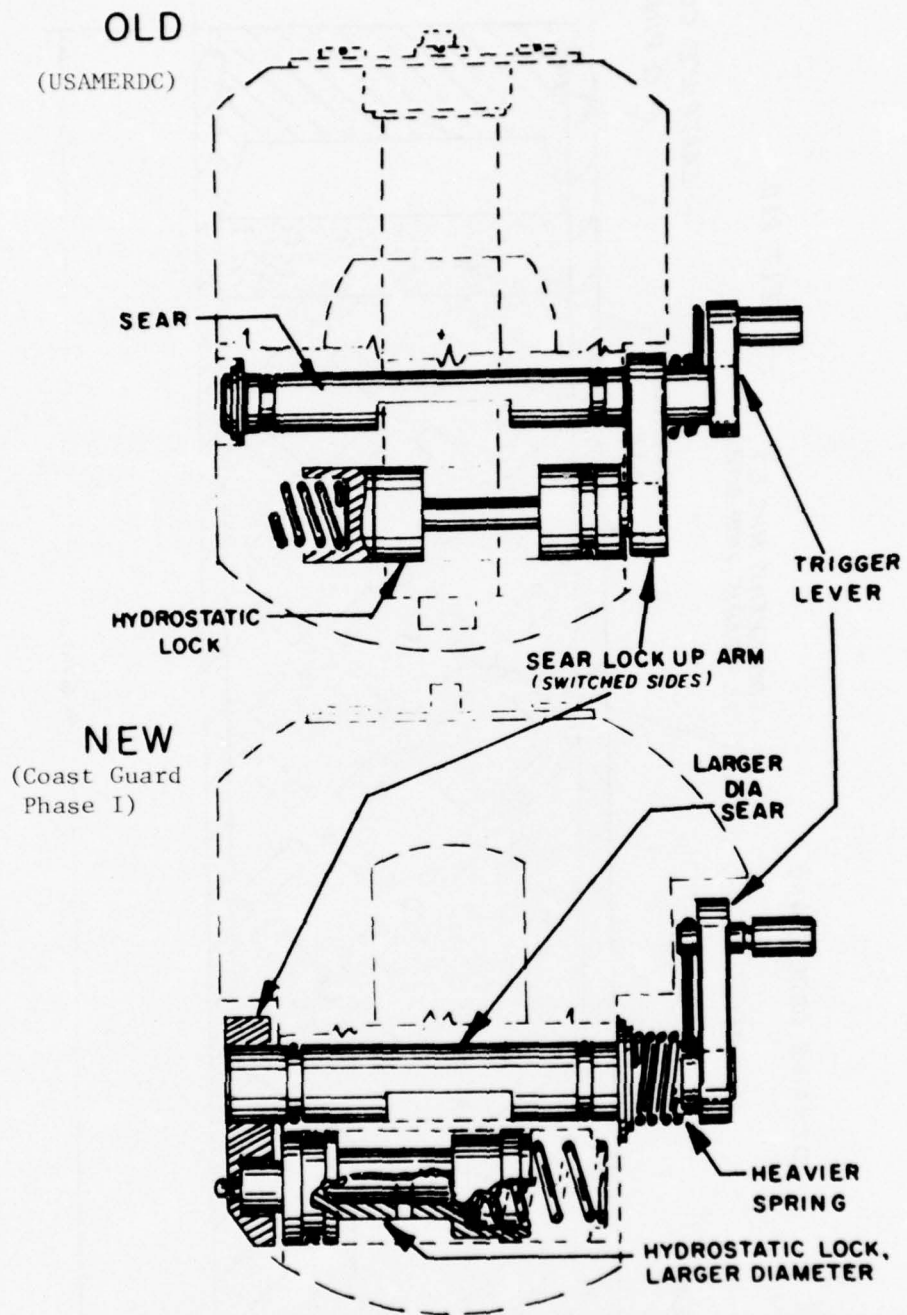

Figure 1. Phase I gunstand.



CROSS SECTION VIEW OF THE SEAR AND HYDROSTATIC LOCK FOR THE OLD AND NEW FIRING MECHANISM DESIGNS

Figure 2. Phase I firing mechanism design improvements.

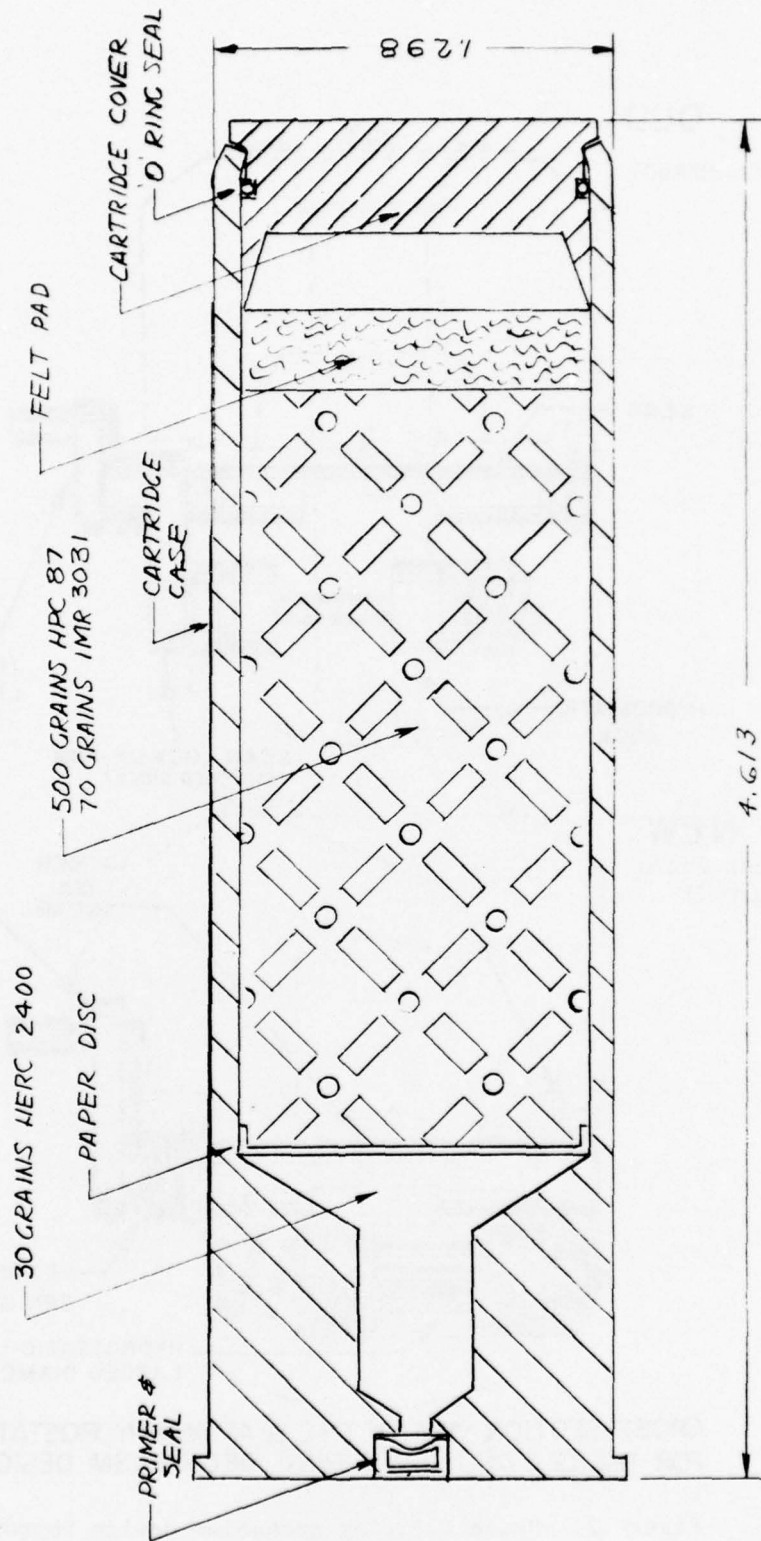
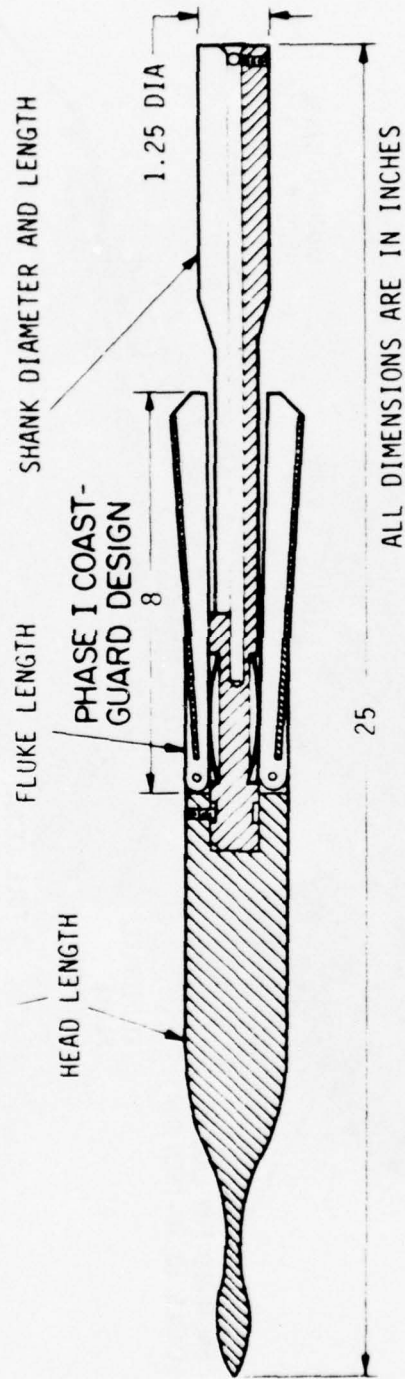

Figure 3. Explosive embedment anchor cartridge schematic.



CROSS SECTION VIEW OF PHASE I ANCHOR DESIGN SHOWING MAJOR CHANGES MADE WITH REFERENCE TO OLD MERDC DESIGN

Figure 4. Phase I explosive embedment anchor projectile.

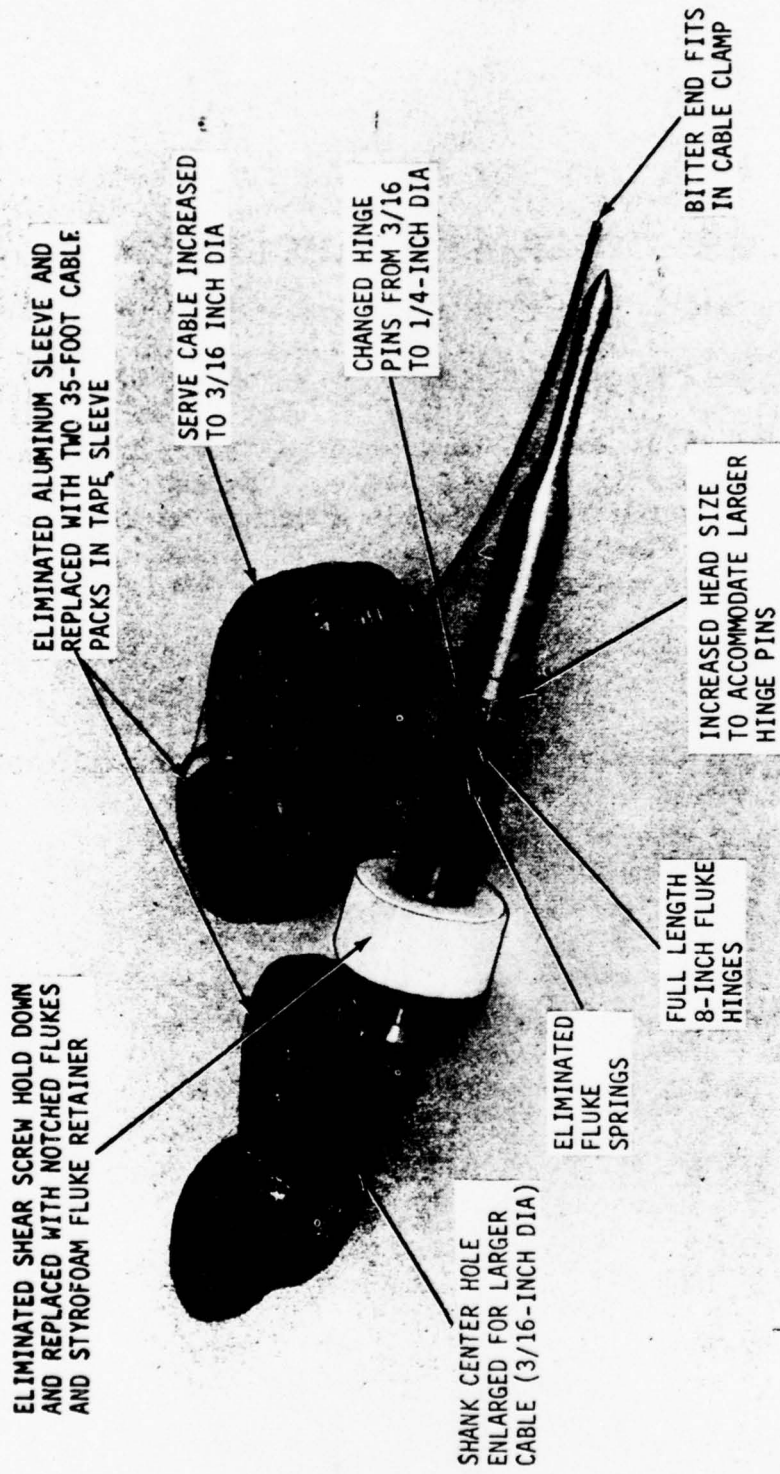

Figure 5. Improved explosive embedment anchor projectile.

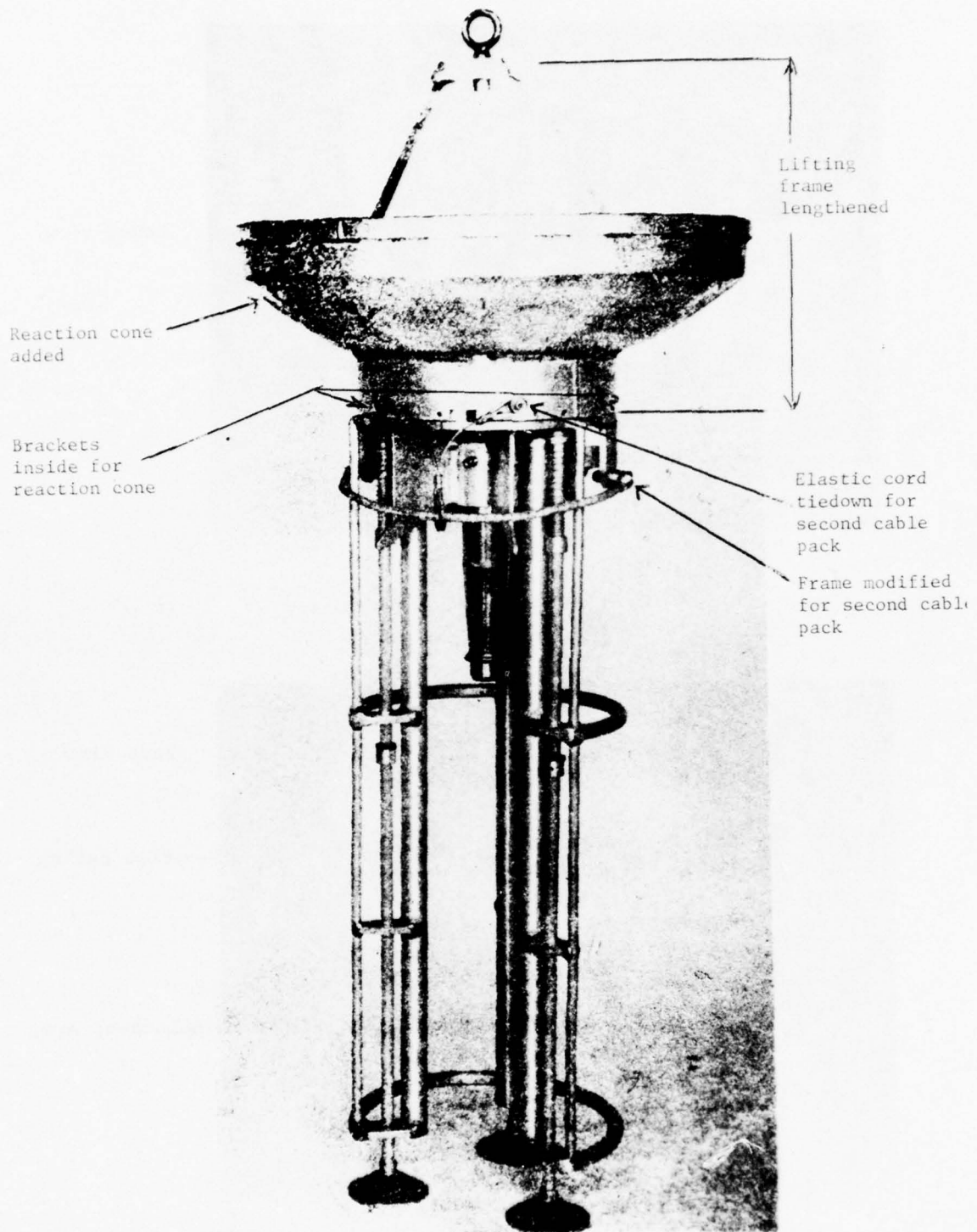
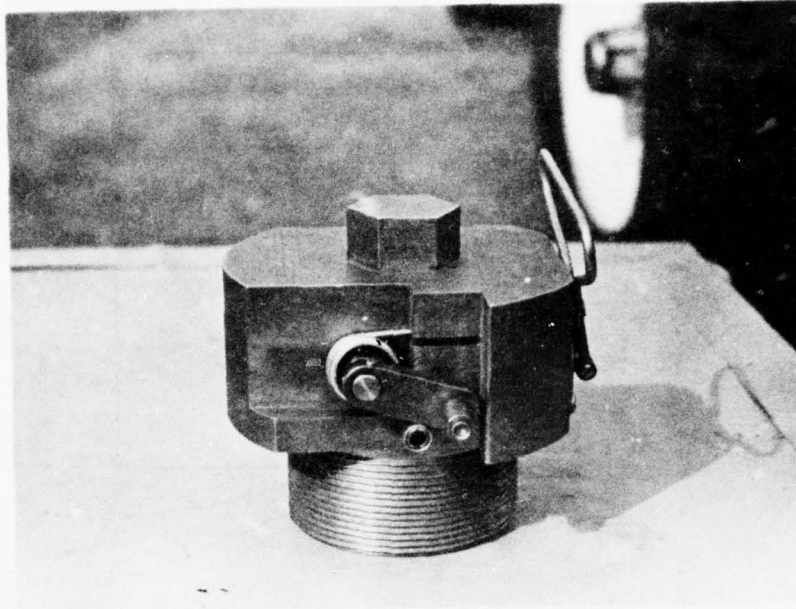
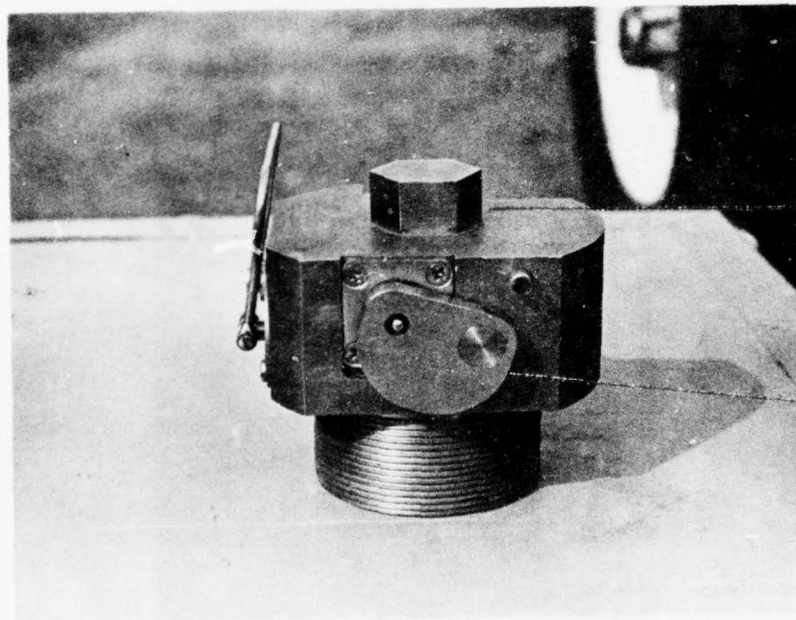

Figure 6. Phase II gunstand.



Front view



Back view

— Flat nut on top

— Lock-up arm

Figure 7. Phase II firing mechanism.

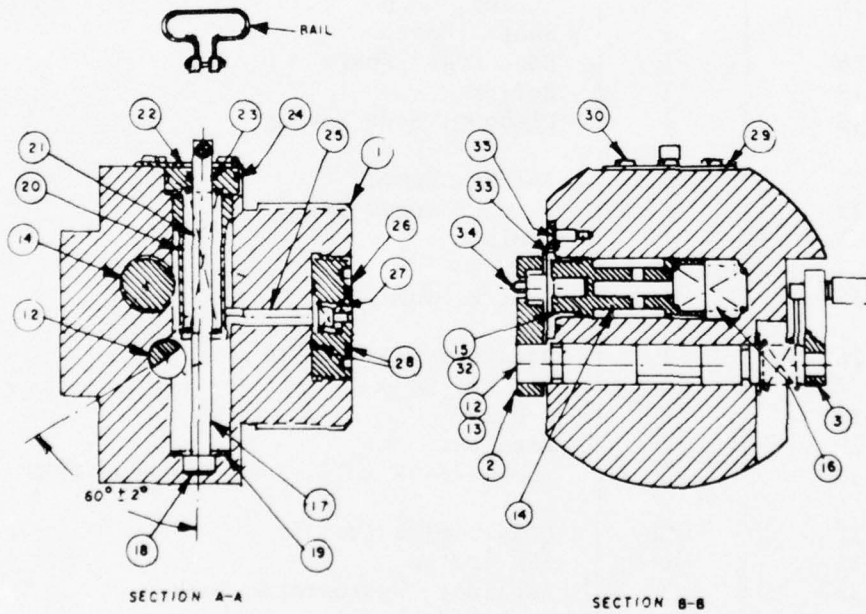
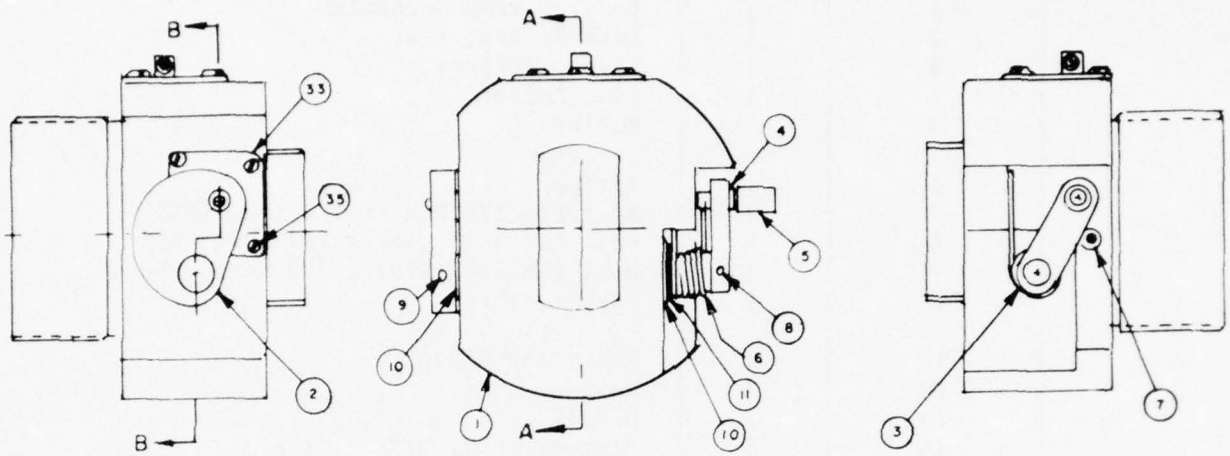
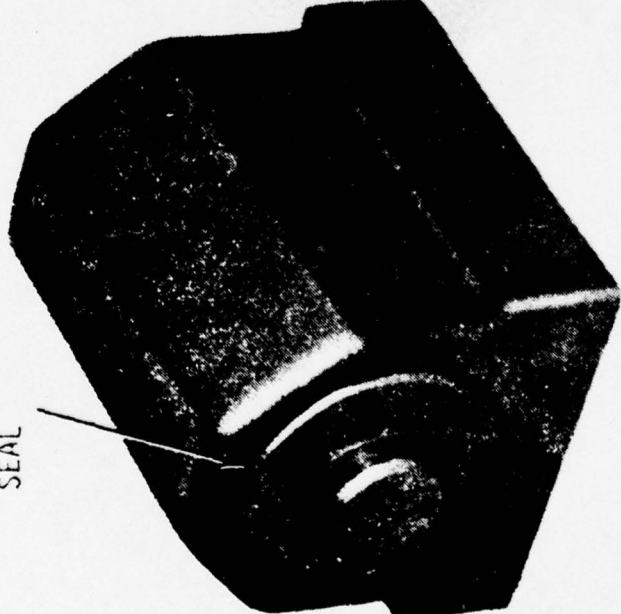

Figure 8. Phase II firing mechanism schematic.

ITEM (FIGURE 8)	QTY	DESCRIPTION
1	1	Body, Firing Mechanism
2	1	Lock-Up Arm, Sear
3	1	Lever, Trigger
4	1	Pin, Roller
5	1	Roller
6	1	Spring
7	1	Roll Pin 1/4 Dia. x 1/2 Long CRES
8	1	Roll Pin 3/32 Dia. x 1/2 Long CRES
9	1	Roll Pin 5/32 Dia. x 7/8 Long CRES
10	2	Washer, Thrust
11	1	Retaining Ringe
12	1	Sear
13	2	O-Ring
14	1	Piston, Lock, Hydrostatic
15	1	Rolling Diaphragm
16	1	Spring, Comp.
17	1	Shaft, Reset
18	1	Cap, Reset Shaft
19	1	Buffer
20	1	Plunger, Side Moving
21	1	Spring, Comp.
22	1	Plug, Plunger End.
23	1	O-Ring
24	1	O-Ring
25	1	Pin, Firing
26	1	Retainer, Firing Pin
27	1	Spring, Comp.
28	2	O-Ring
29	1	Retainer
30	3	Screw #6-32 x 1/4 Long Pan Head CRES
31	AR	Molysulfide (MoS ₂)
32	AR	55M Grease
33	1	Retainer, Hydrostatic Lock
34	1	Lock Pin
35	4	Screw #6-32 x 1/4 Lg. 100° Flat Head CRES
36	1	Bail

Figure 8a. Nomenclature; Phase II firing mechanism schematic.

O-RING TYPE
SEAL



PHASE I

FLEXIBLE
DIAPHRAGM
TYPE SEAL

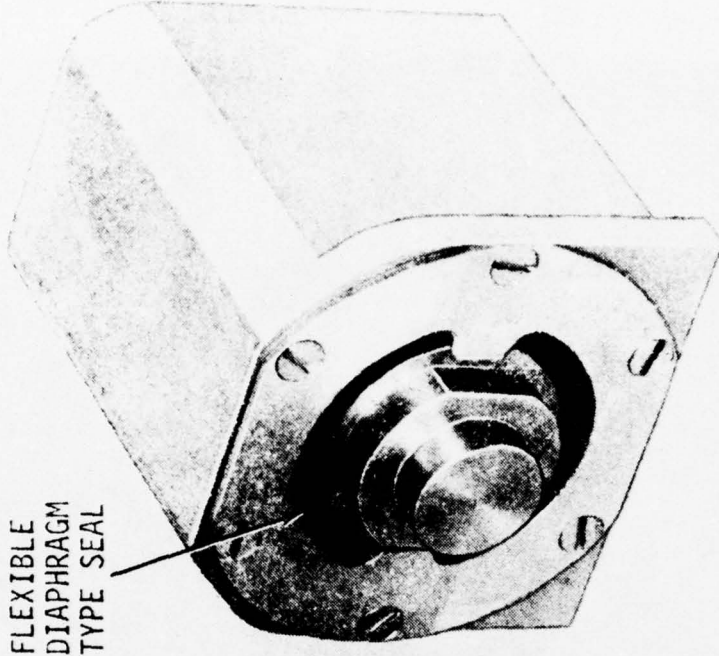

PHASE II

Figure 9. Redundant hydrostatic lock (for trigger plate).

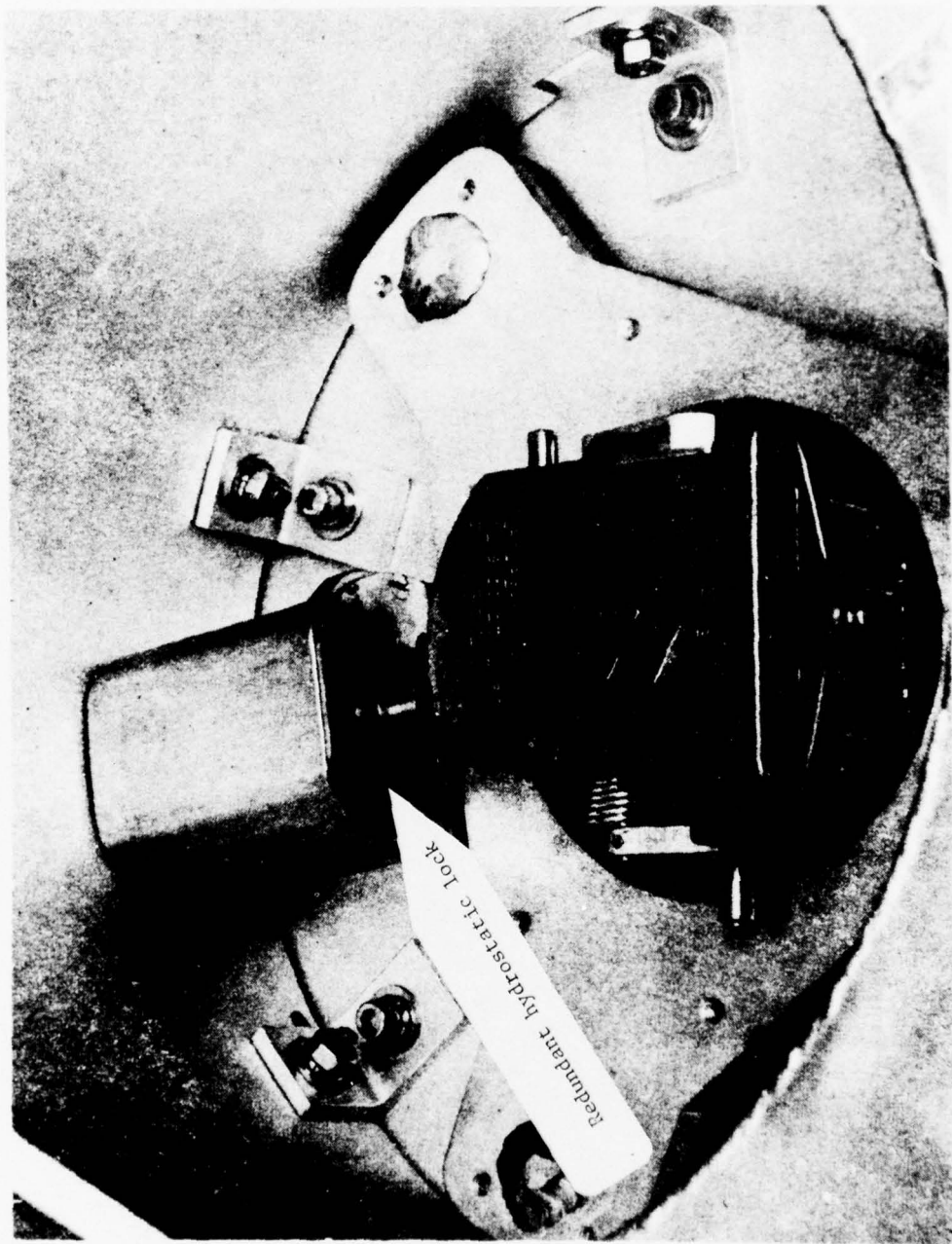

Figure 9a. Redundant hydrostatic lock in place.

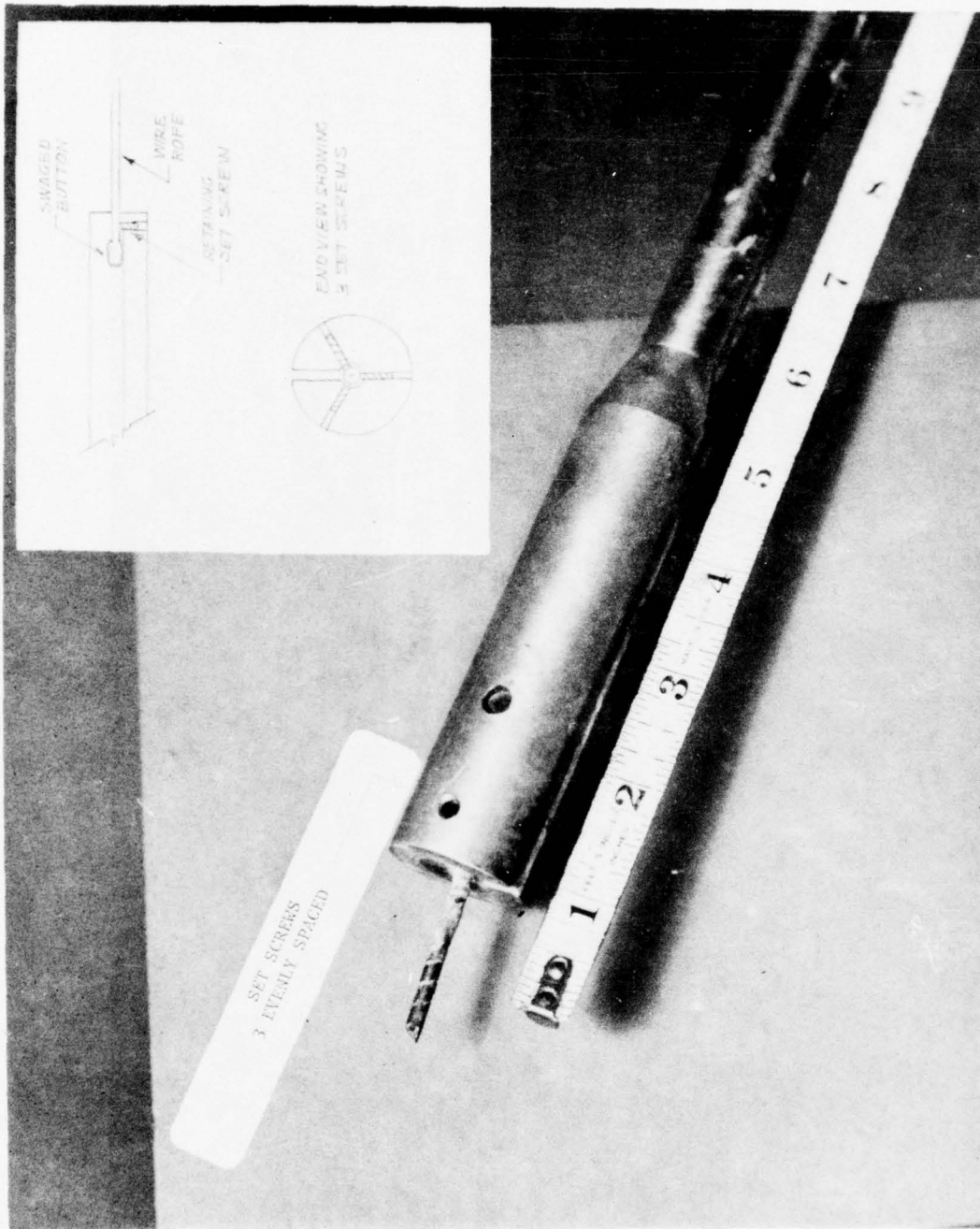

Figure 10. Anchor projectile - wire rope fastening detail.

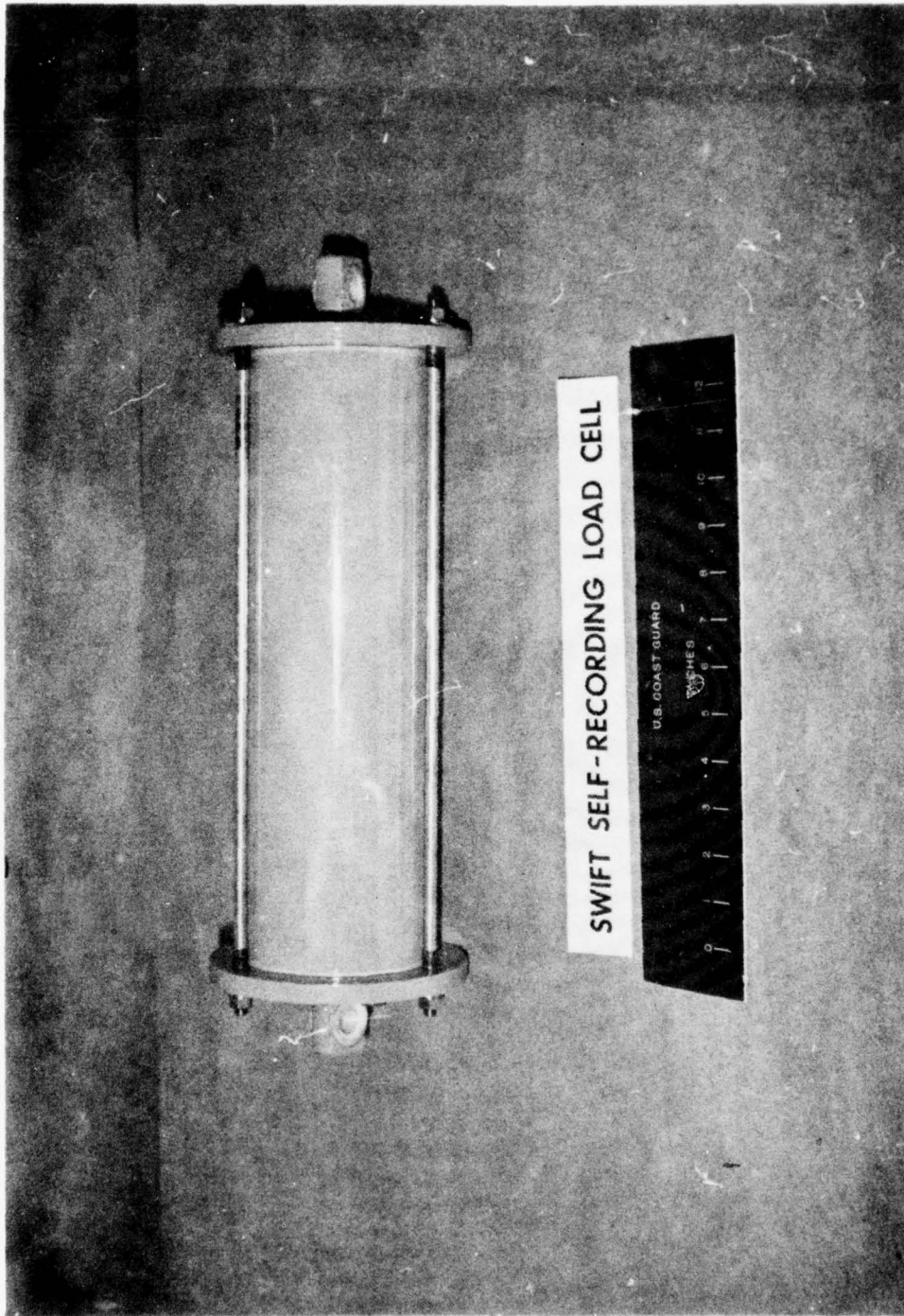

Figure 11. Swift load cell.

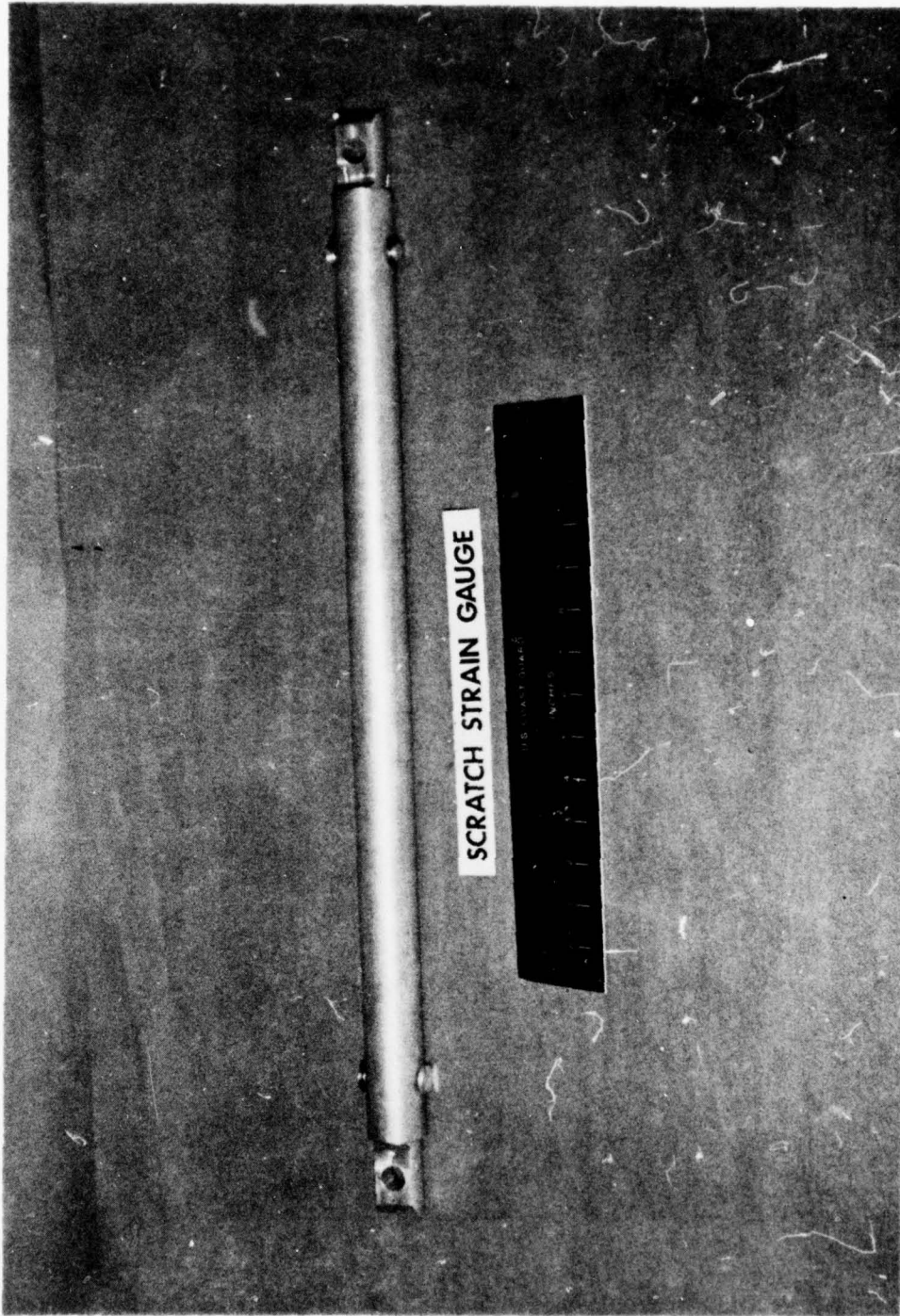

Figure 12. Prewitt strain gage.

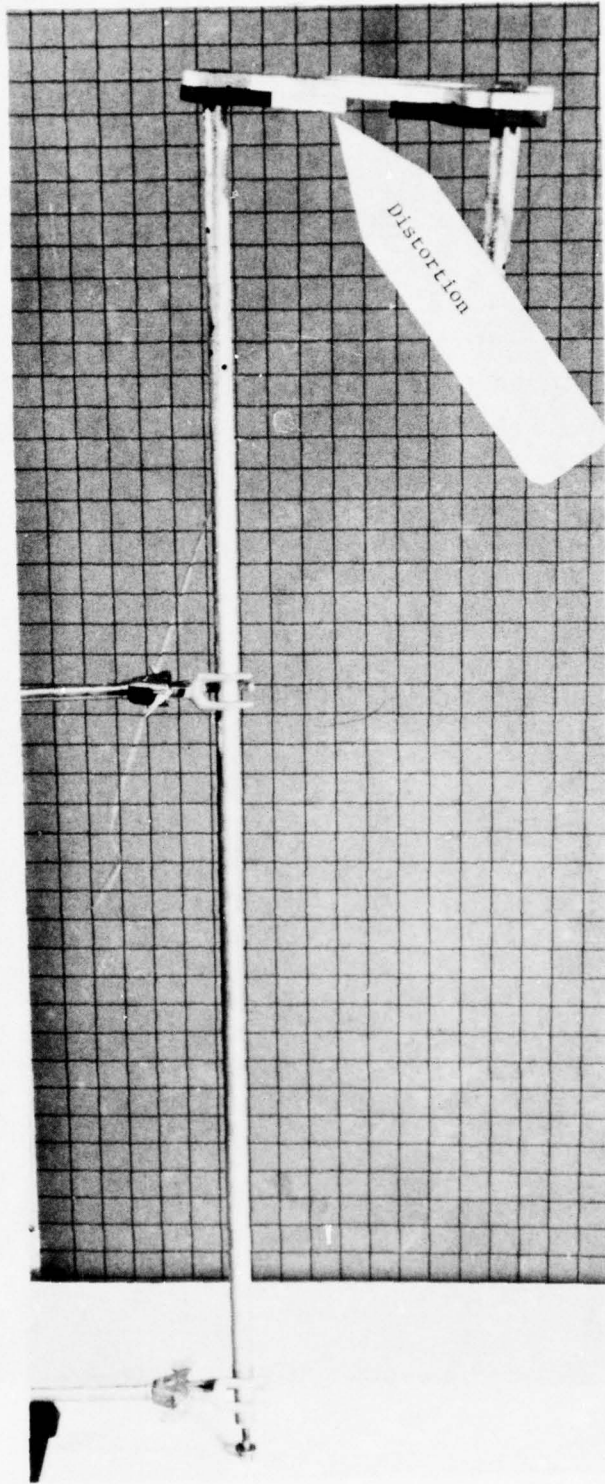
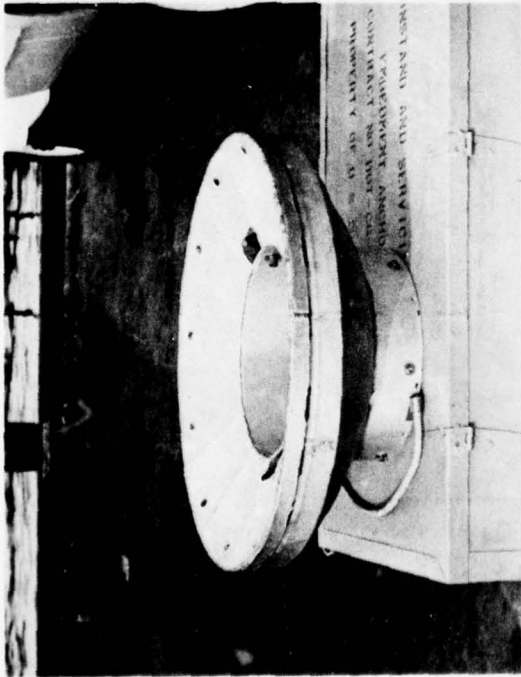
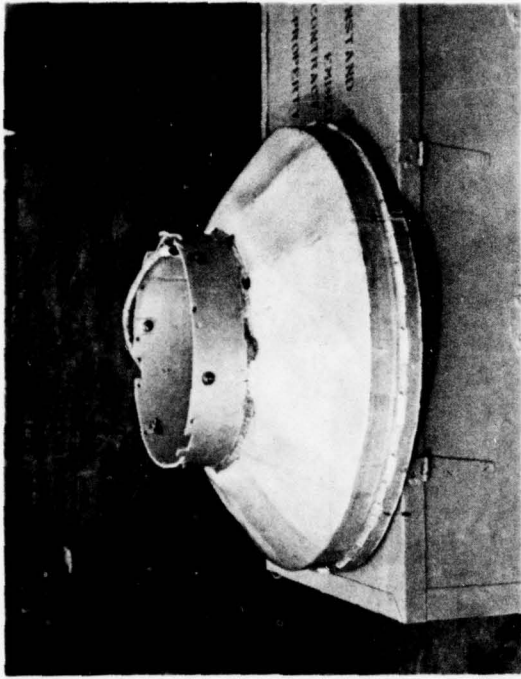
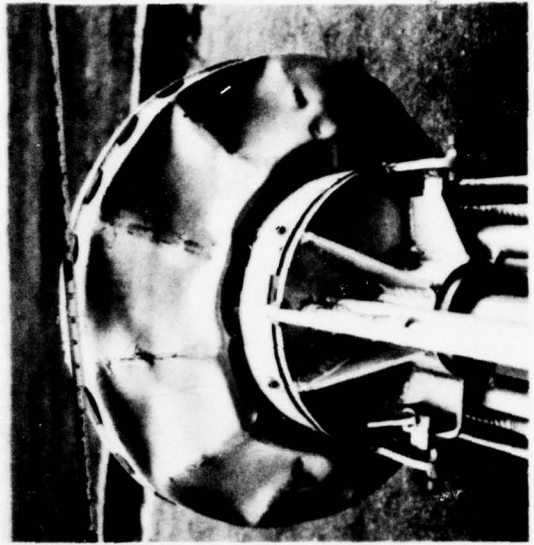

Figure 13. Trigger plate distortion.



Bottom view ↕



↙ 10 firings ↘

← 35 firings →

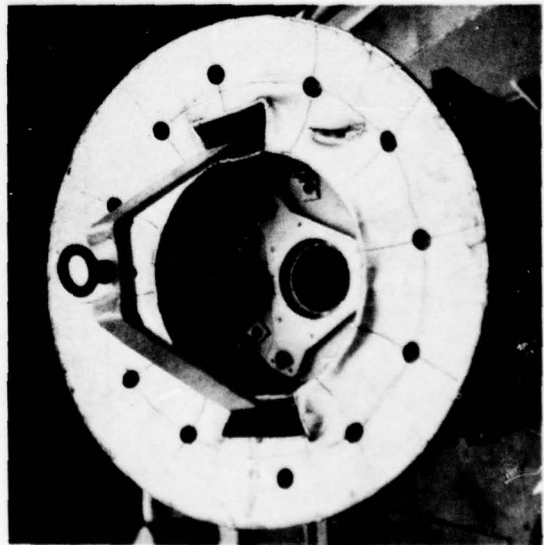

Top view ↕

Figure 14. Reaction cone damage.

Rigid
reaction
cone

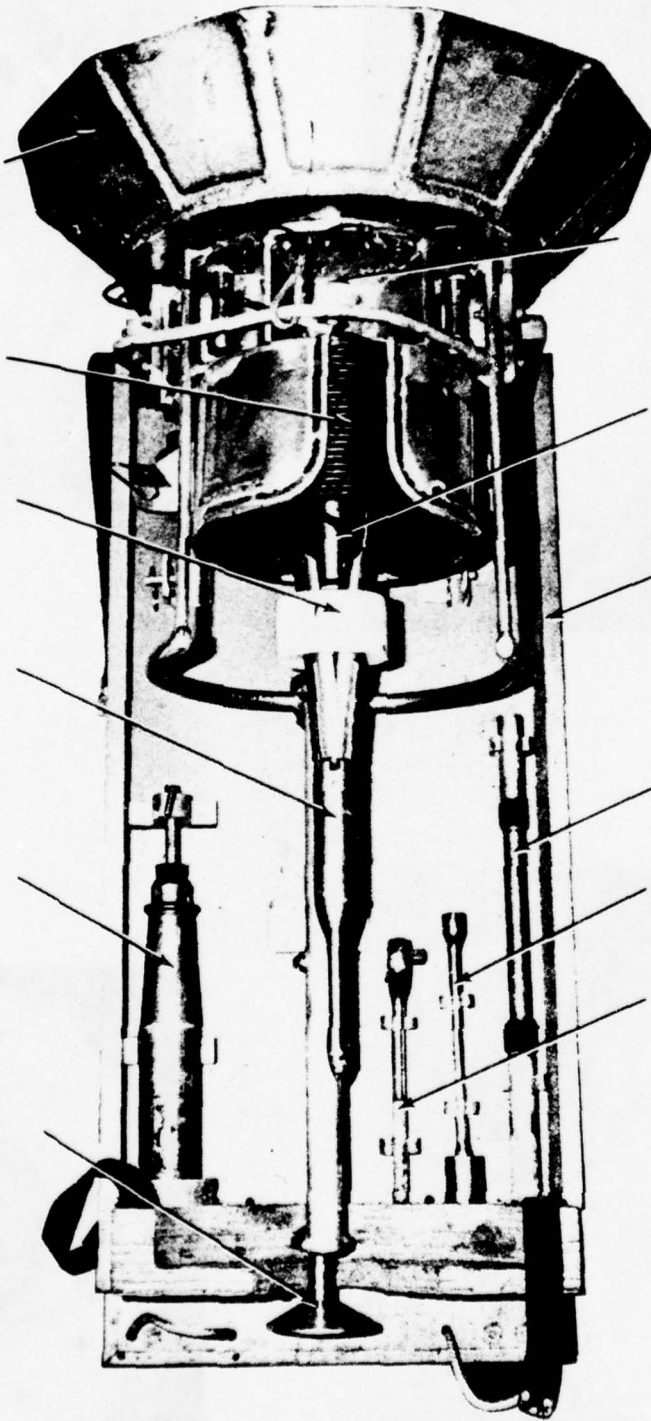

Figure 15. New rigid reaction cone.

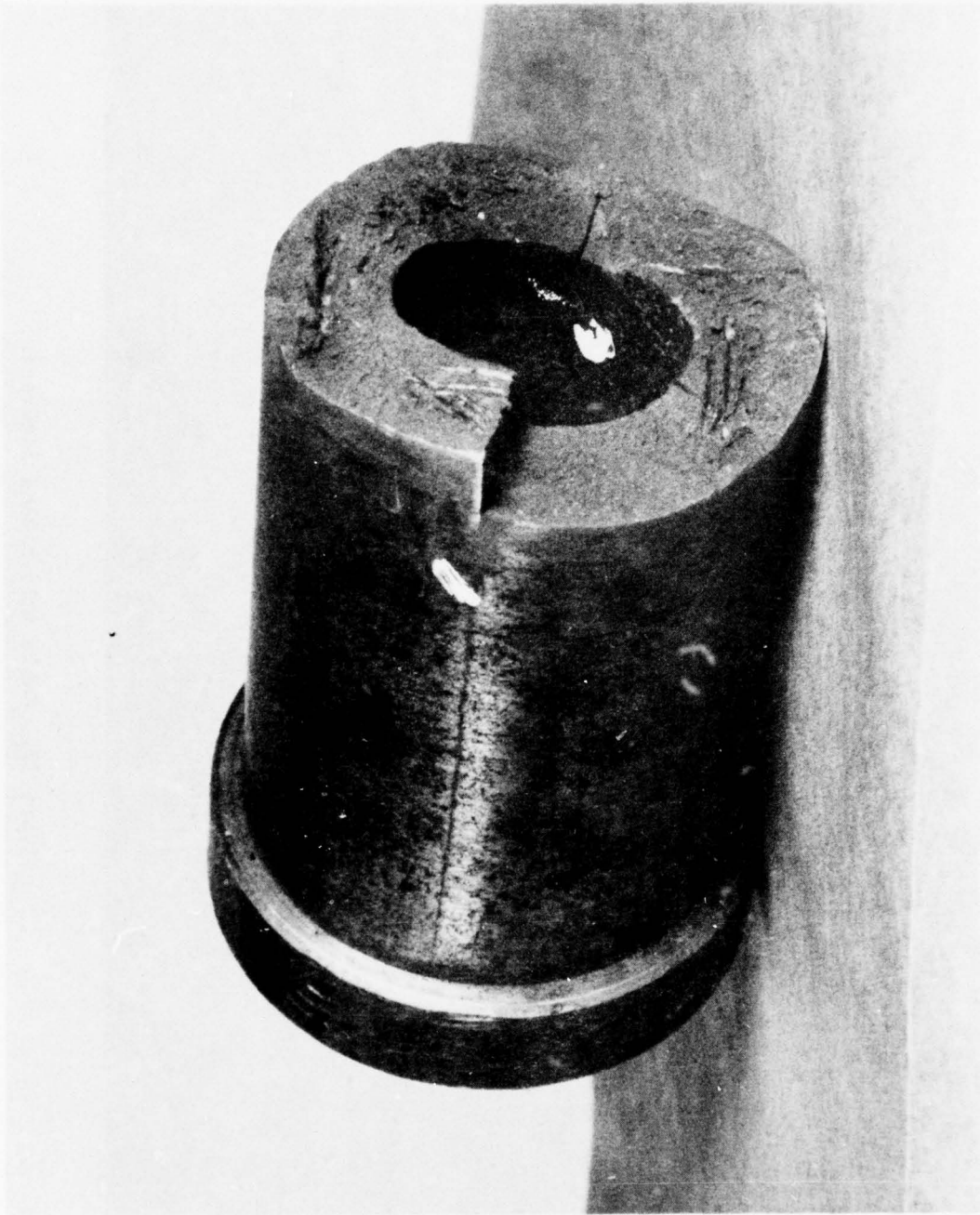

Figure 16. Failed gun barrel.

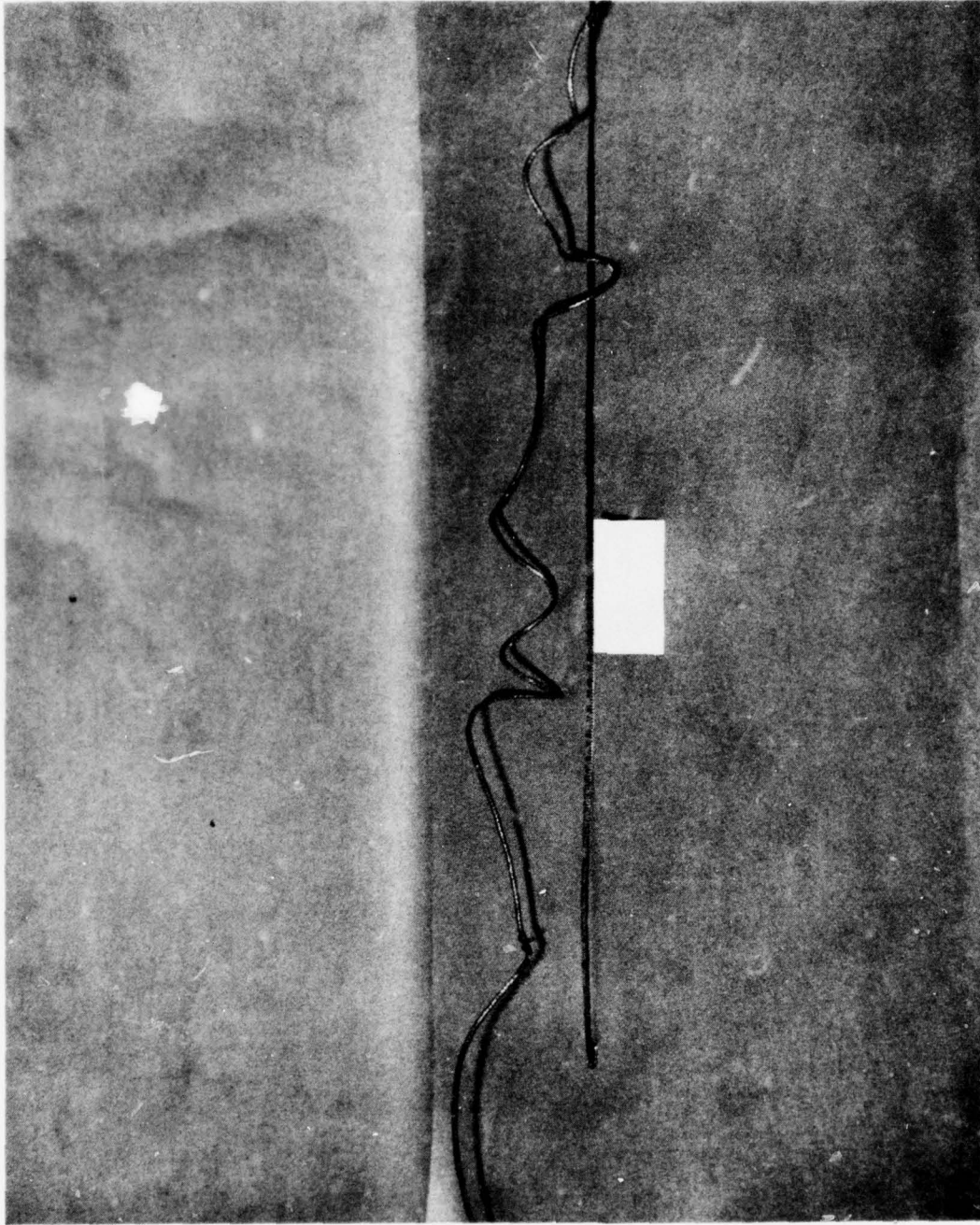

Figure 17. Cable lx19 kinked figure-8.

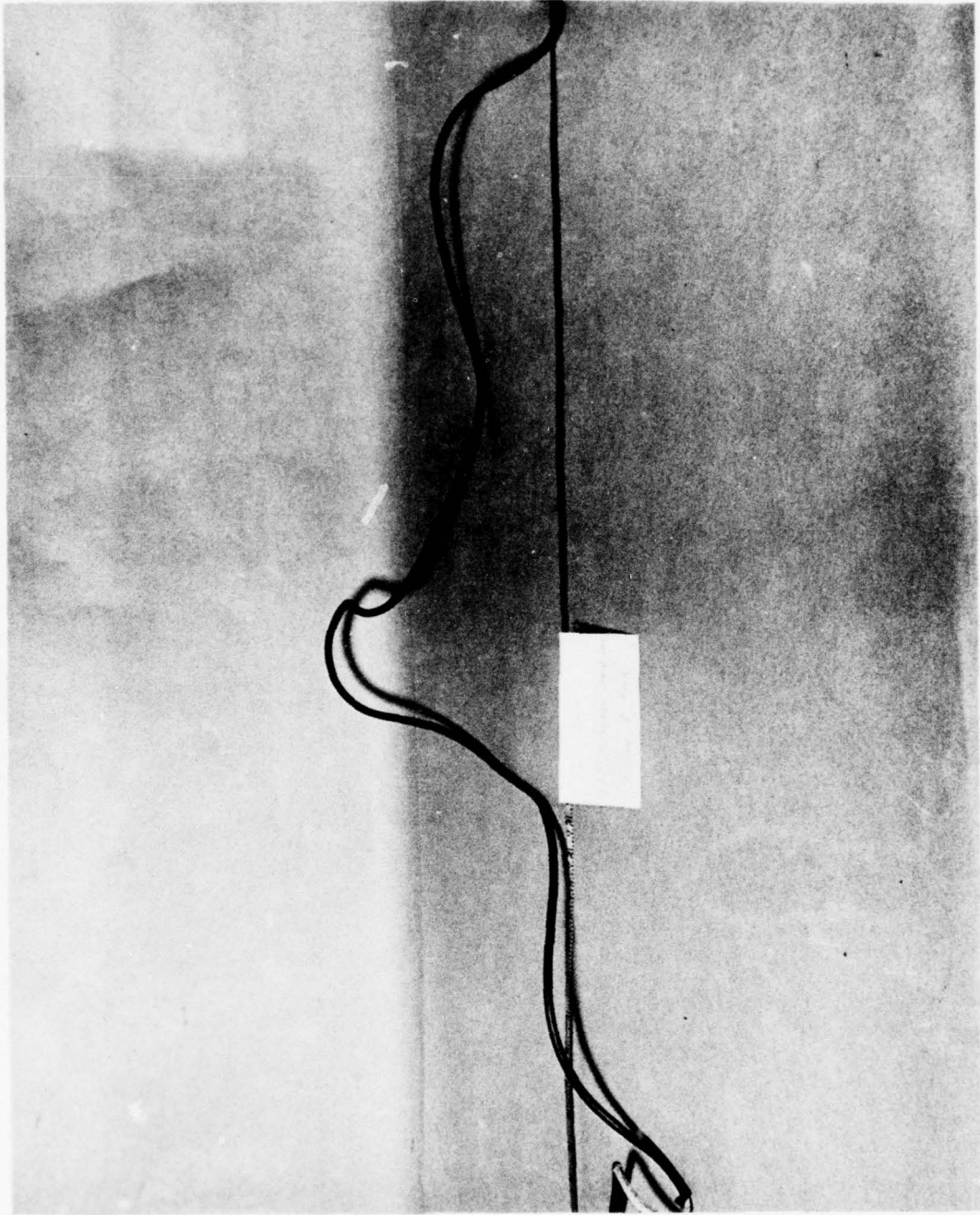

Figure 18. Cable 7x7 kinked figure-8.

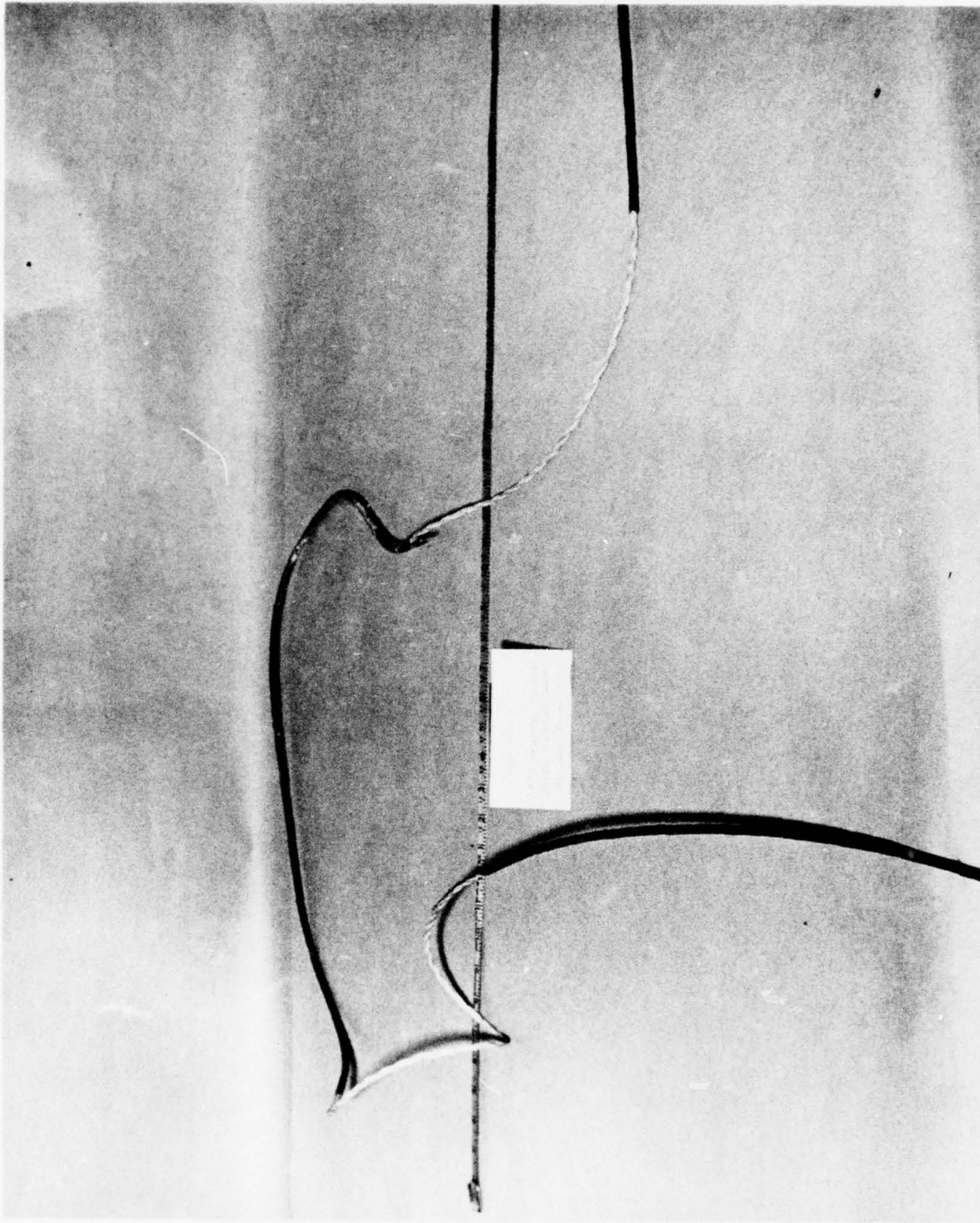

Figure 19. Cable 3x19 kinked faking board.

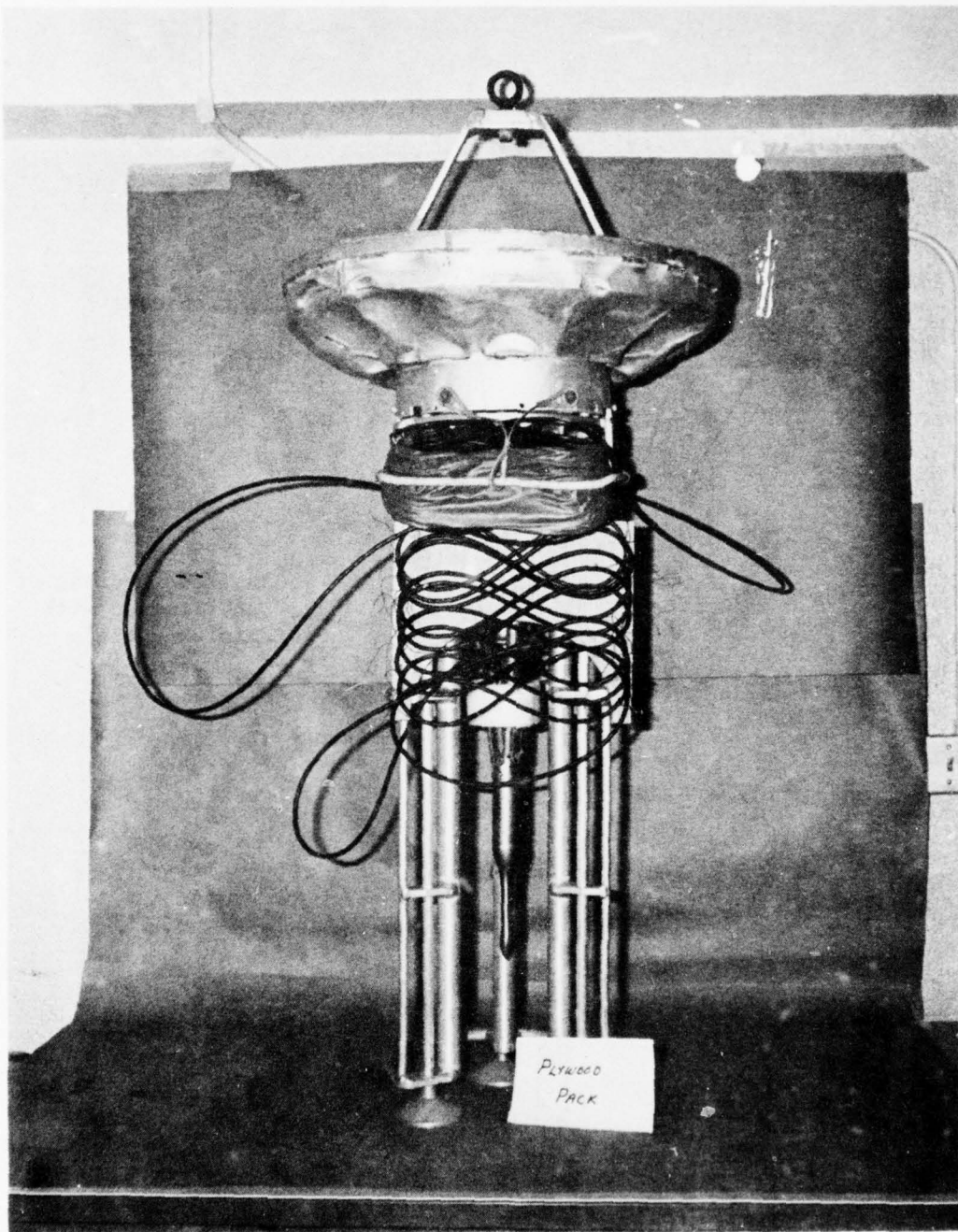

Figure 19a. Faking board arrangement.

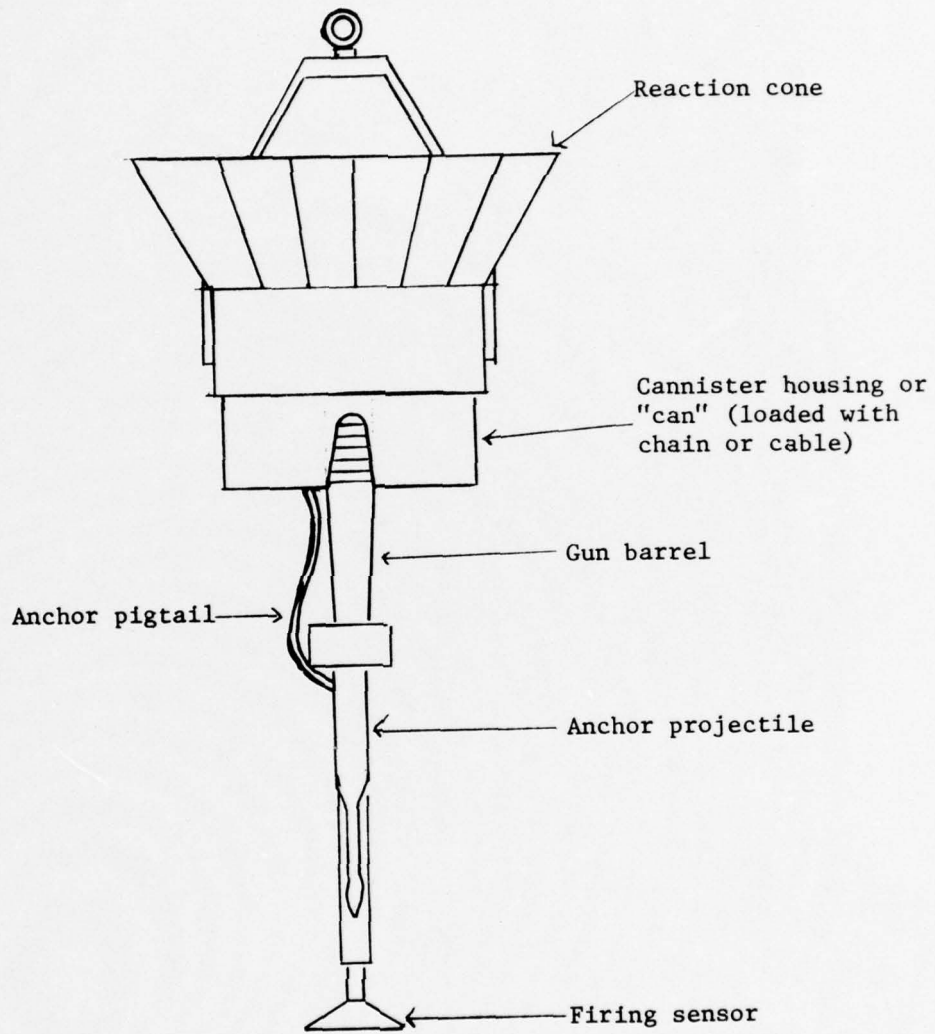

Figure 20. Can pack on gunstand - barrel inside.

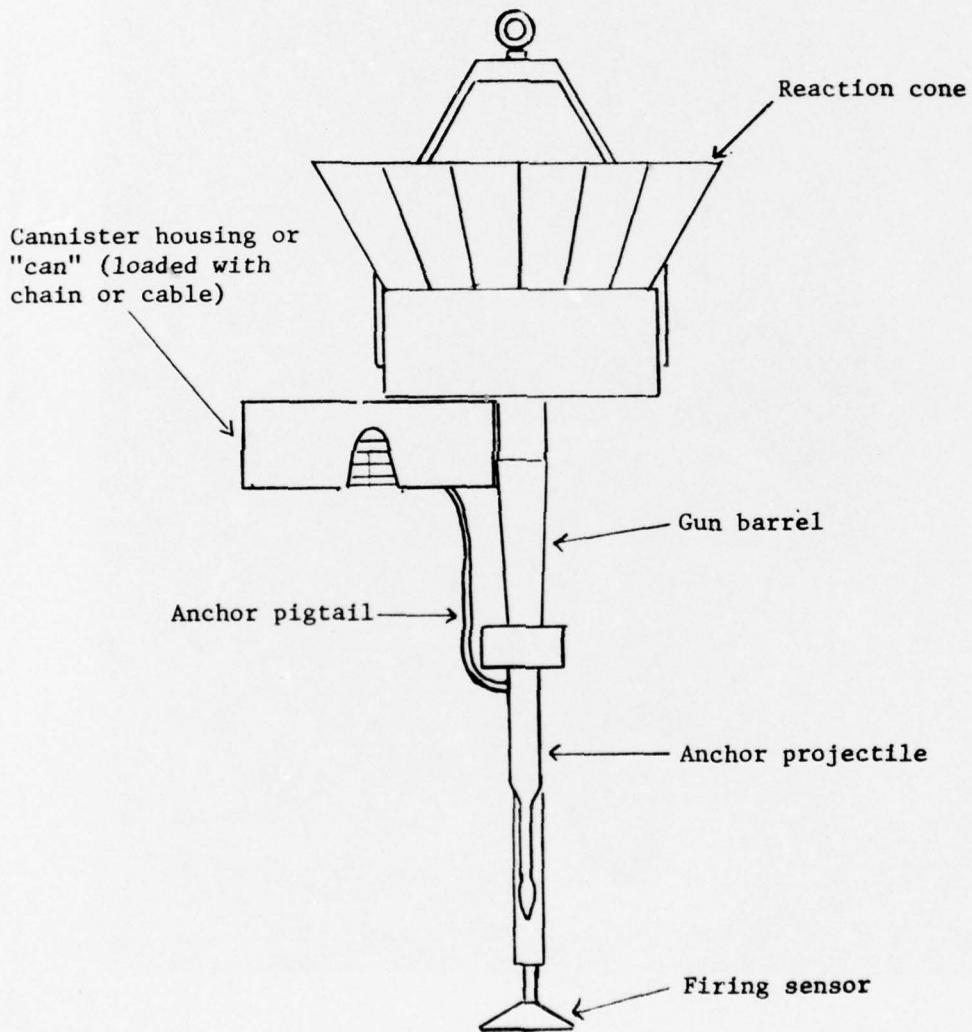

Figure 21. Can pack on gunstand - barrel outside.

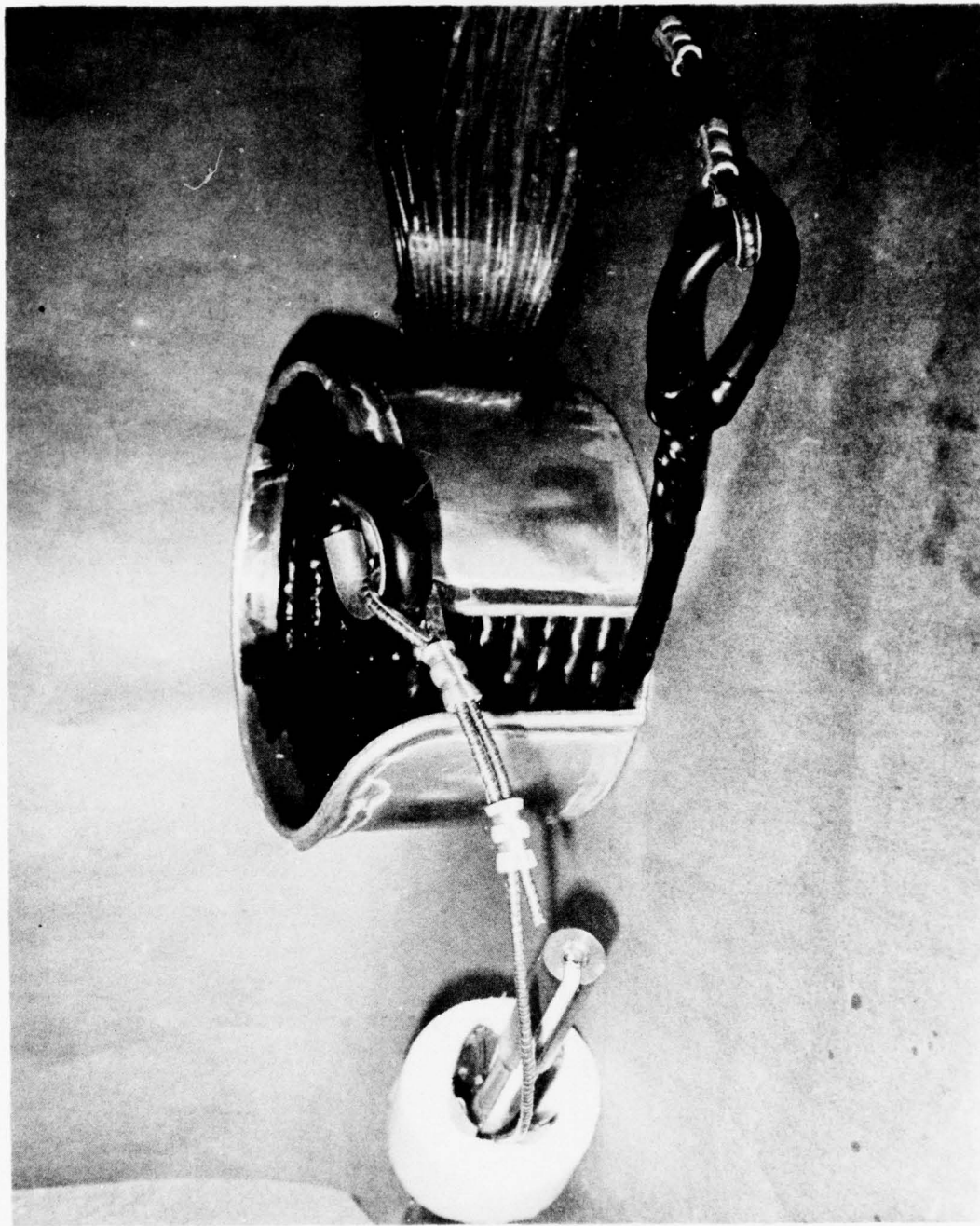

Figure 22. Cable, 1/2" jacketed nylon.

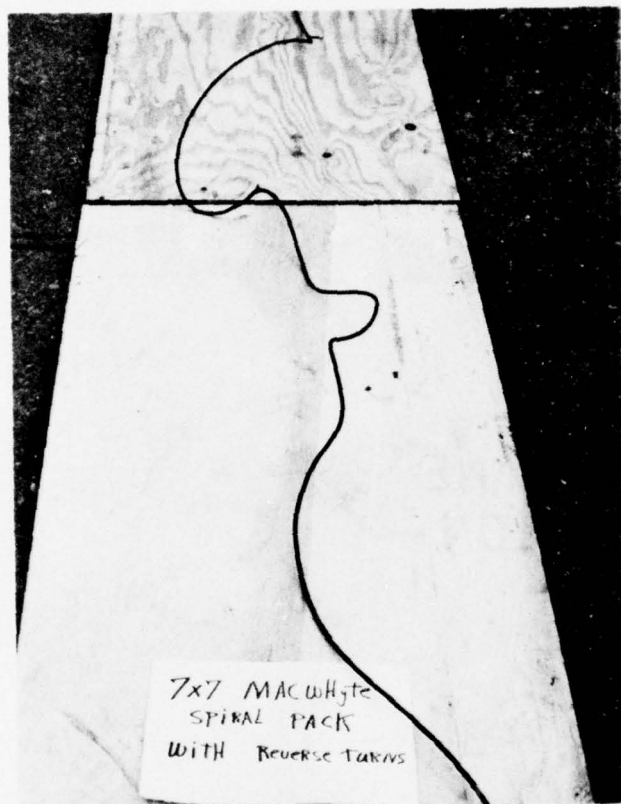
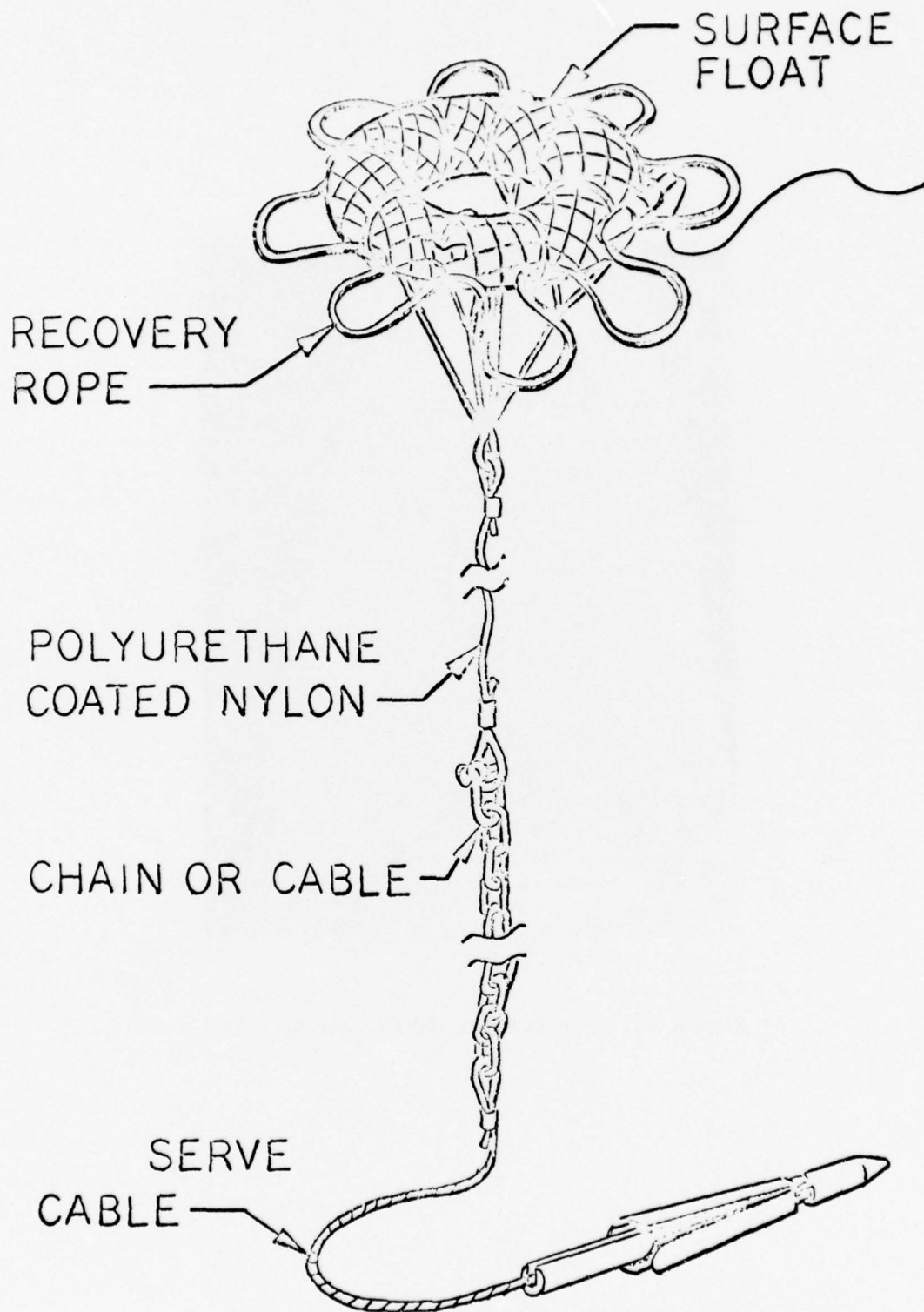

Figure 23. Pre-twisted cable, 7x7 Spacelay.



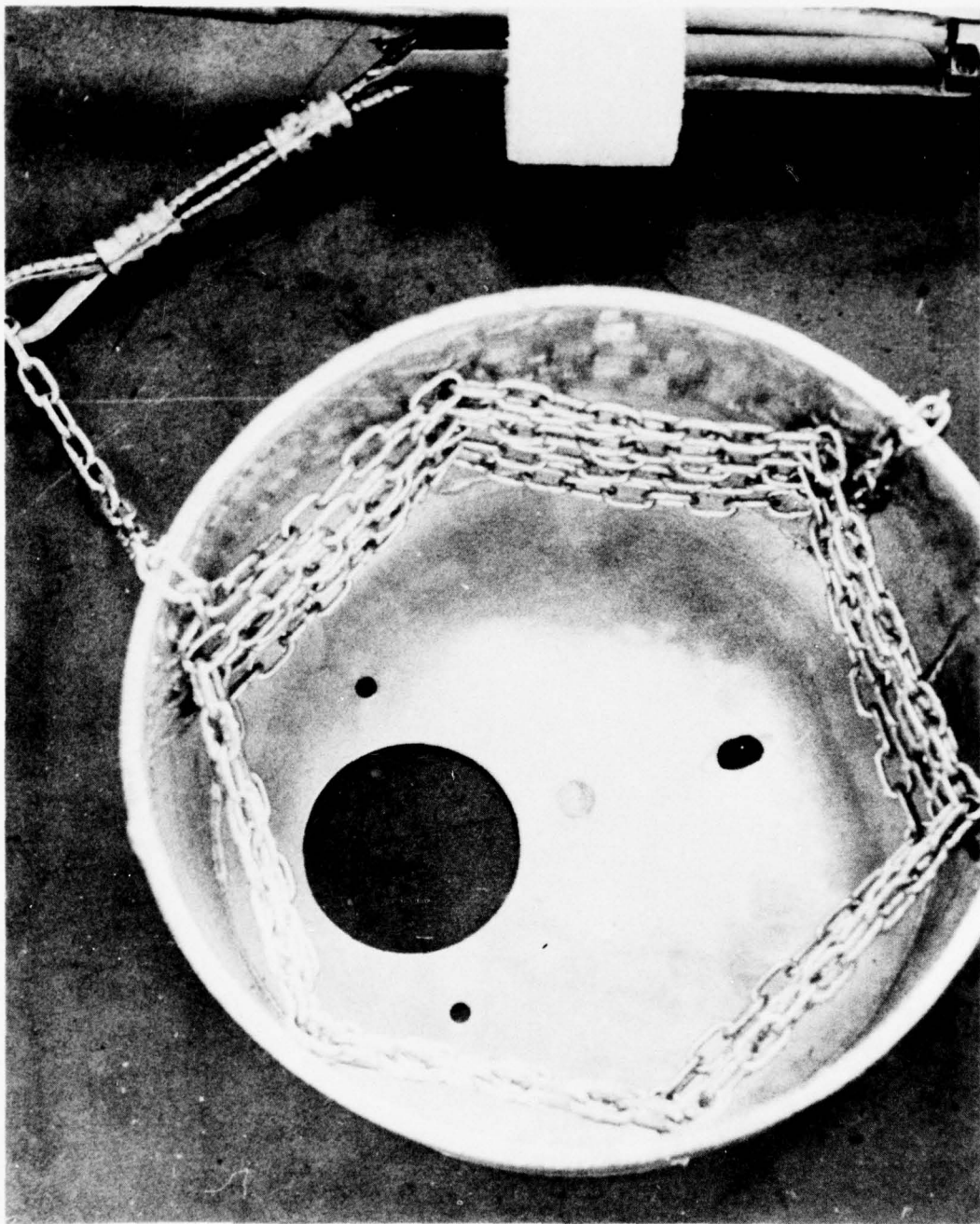

Figure 25. Chain pack in can.

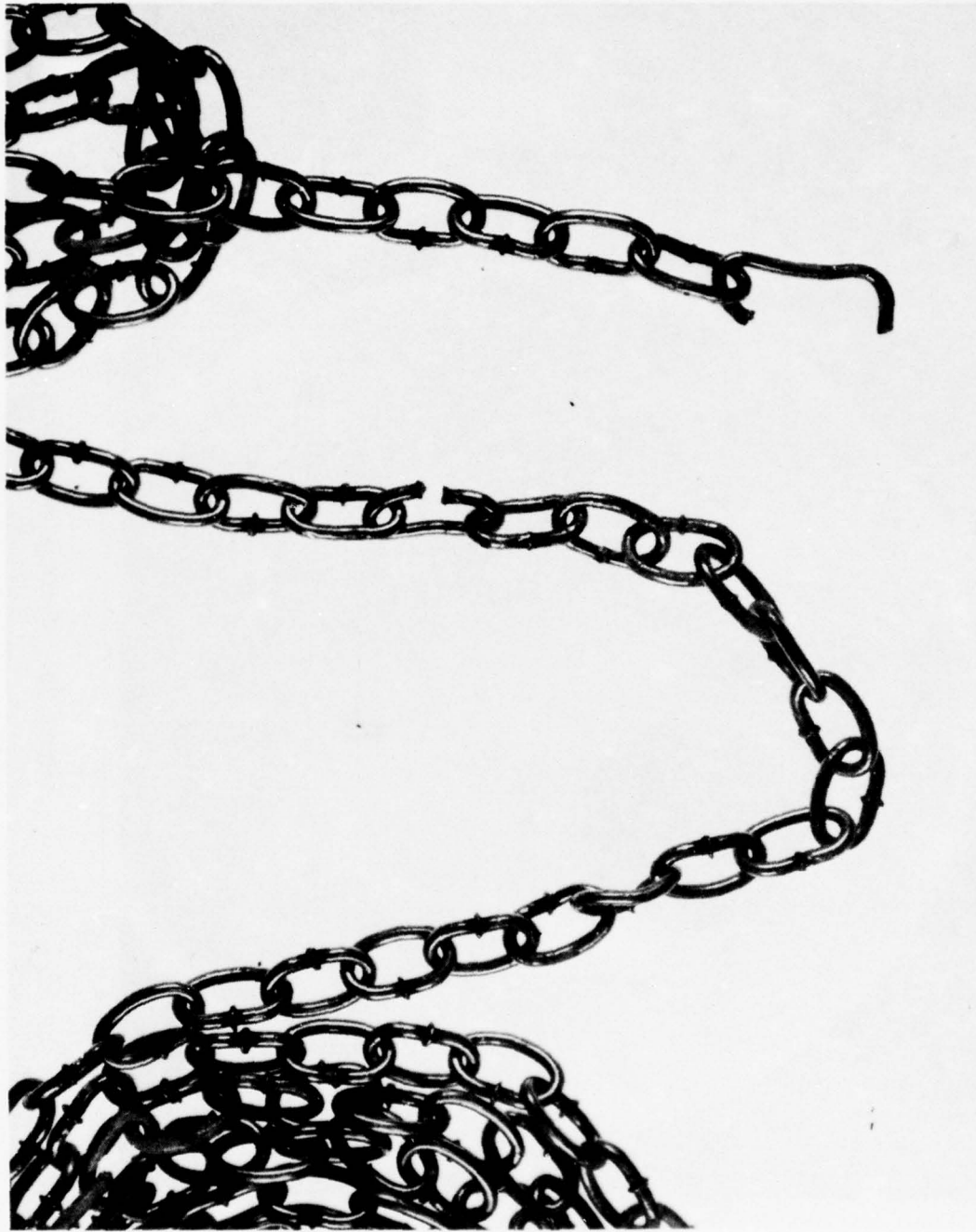
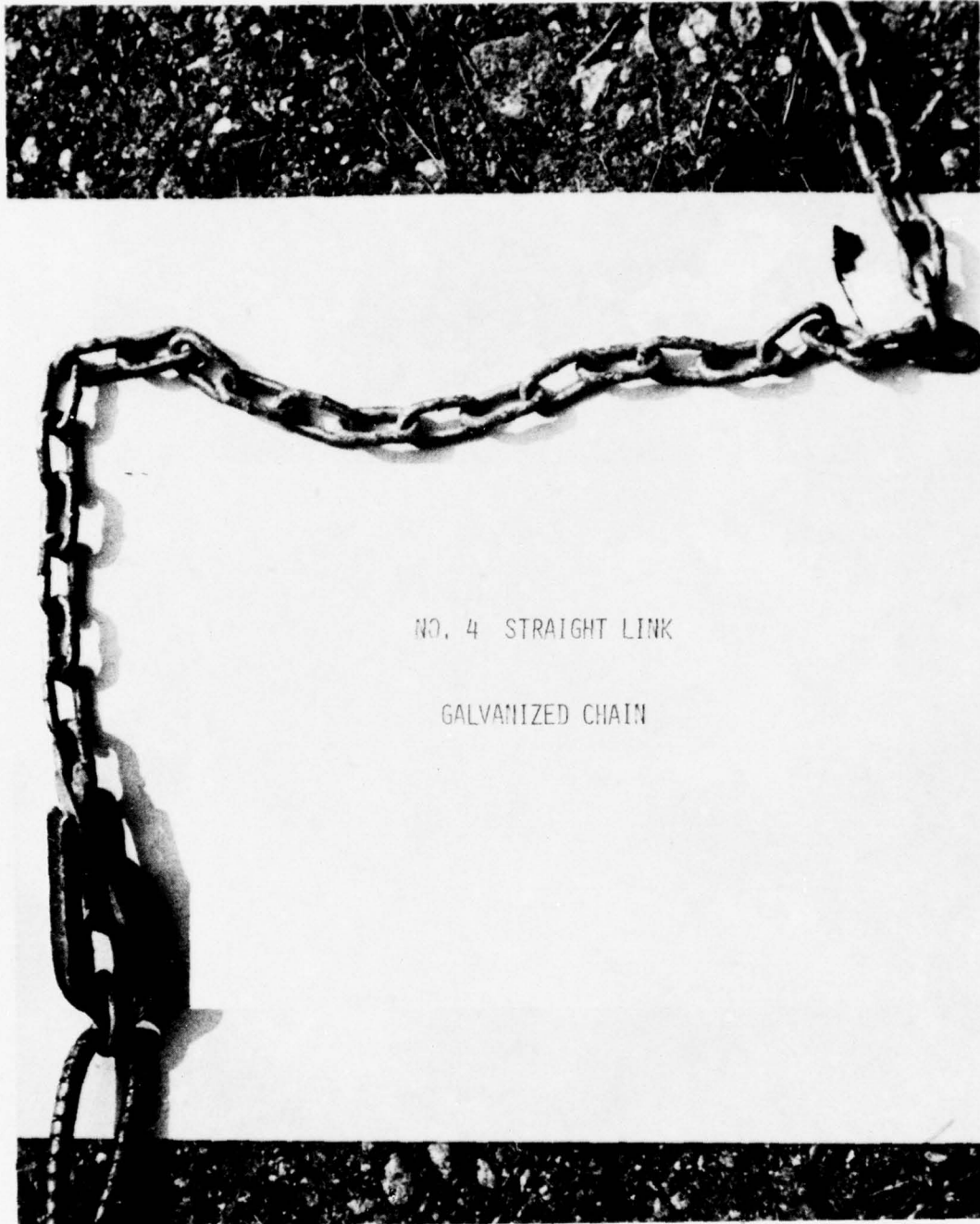

Figure 26. Stainless steel chain showing elongated links after firing.



NO. 4 STRAIGHT LINK

GALVANIZED CHAIN

Figure 27. Galvanized No. 4 chain - failed links.

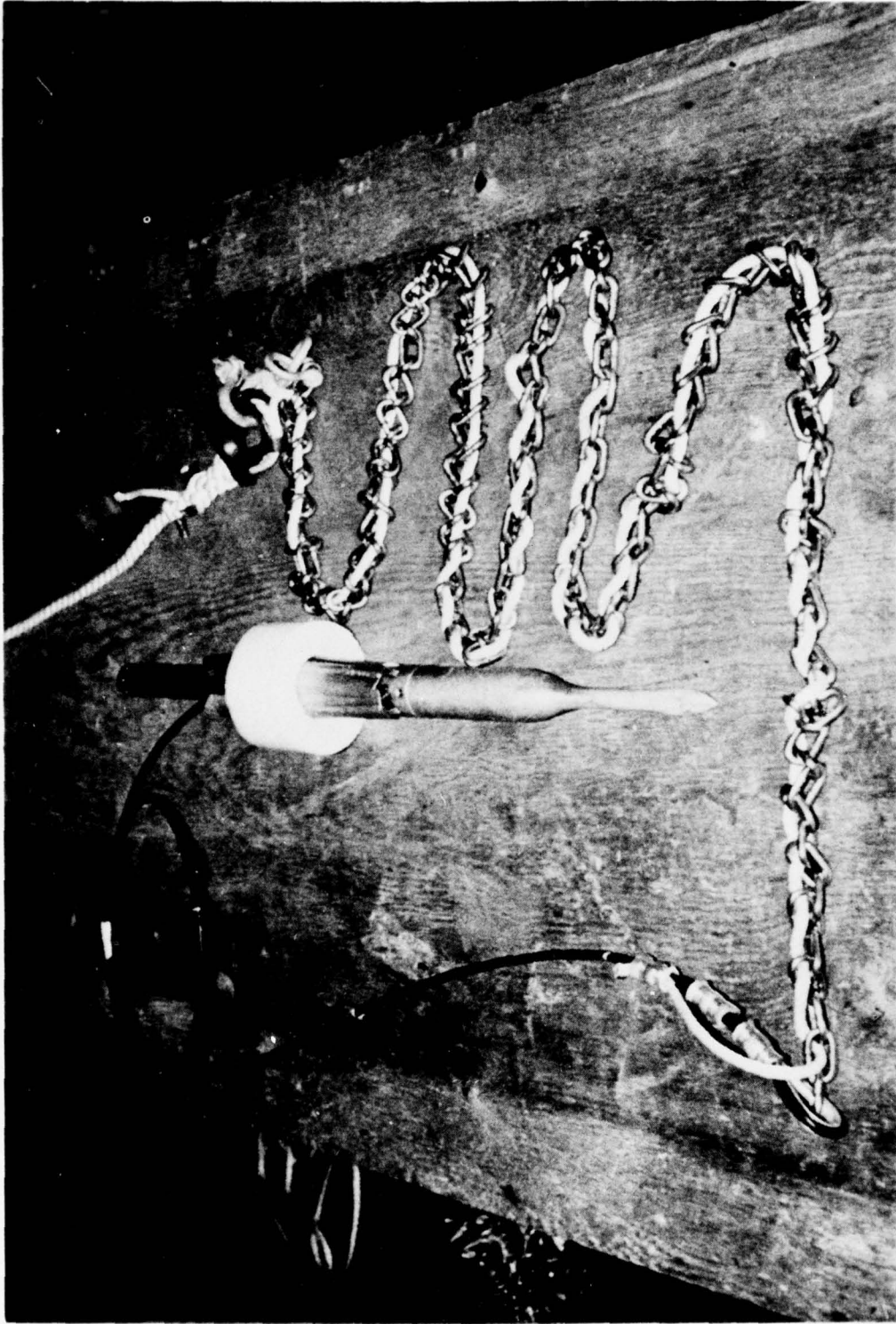

Figure 28. Chain mooring with "shock cord" (before firing).

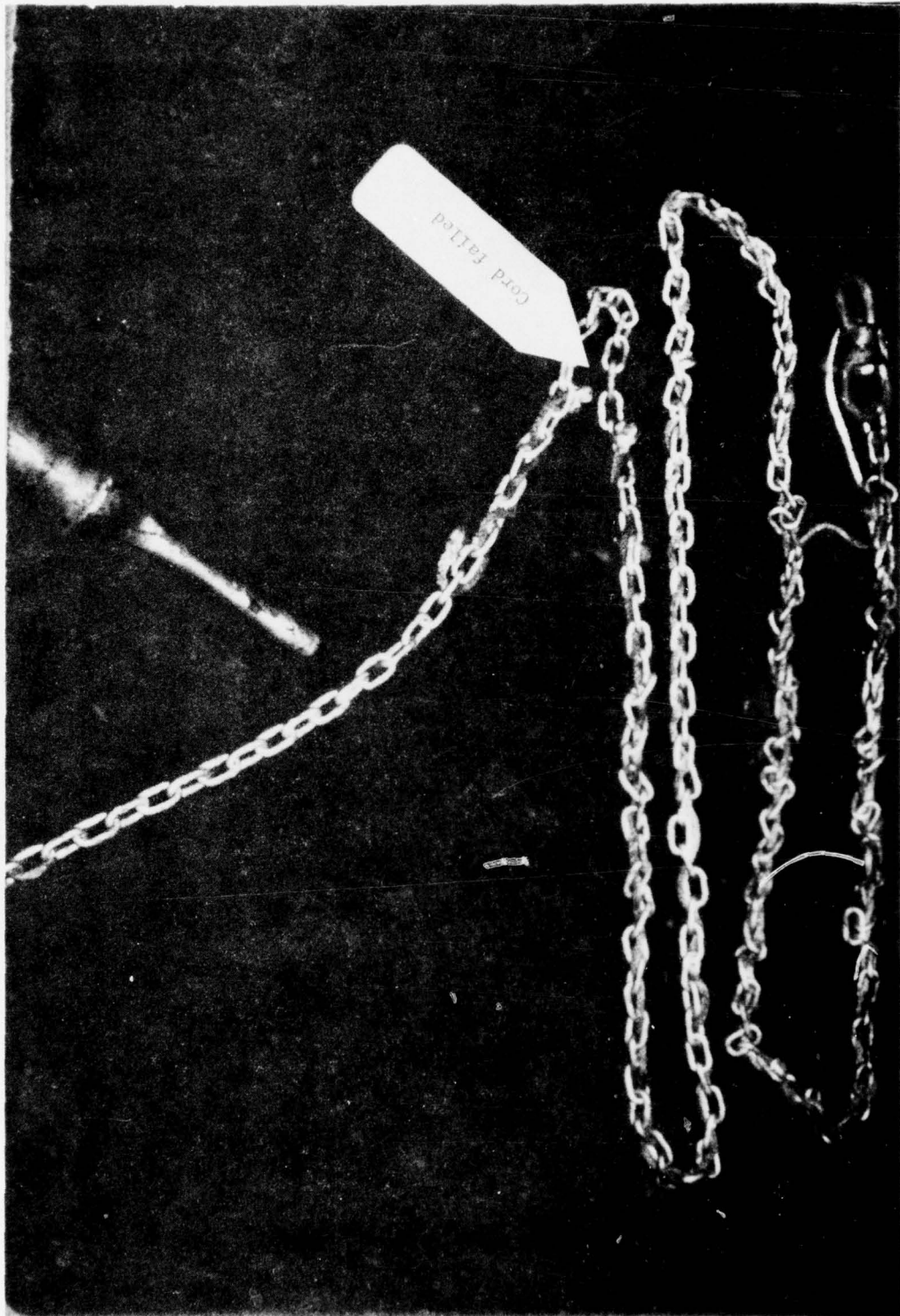

Figure 29. Chain mooring with "shock cord" (after firing).



Figure 30. Chain mooring with "elastic band" (before firing).

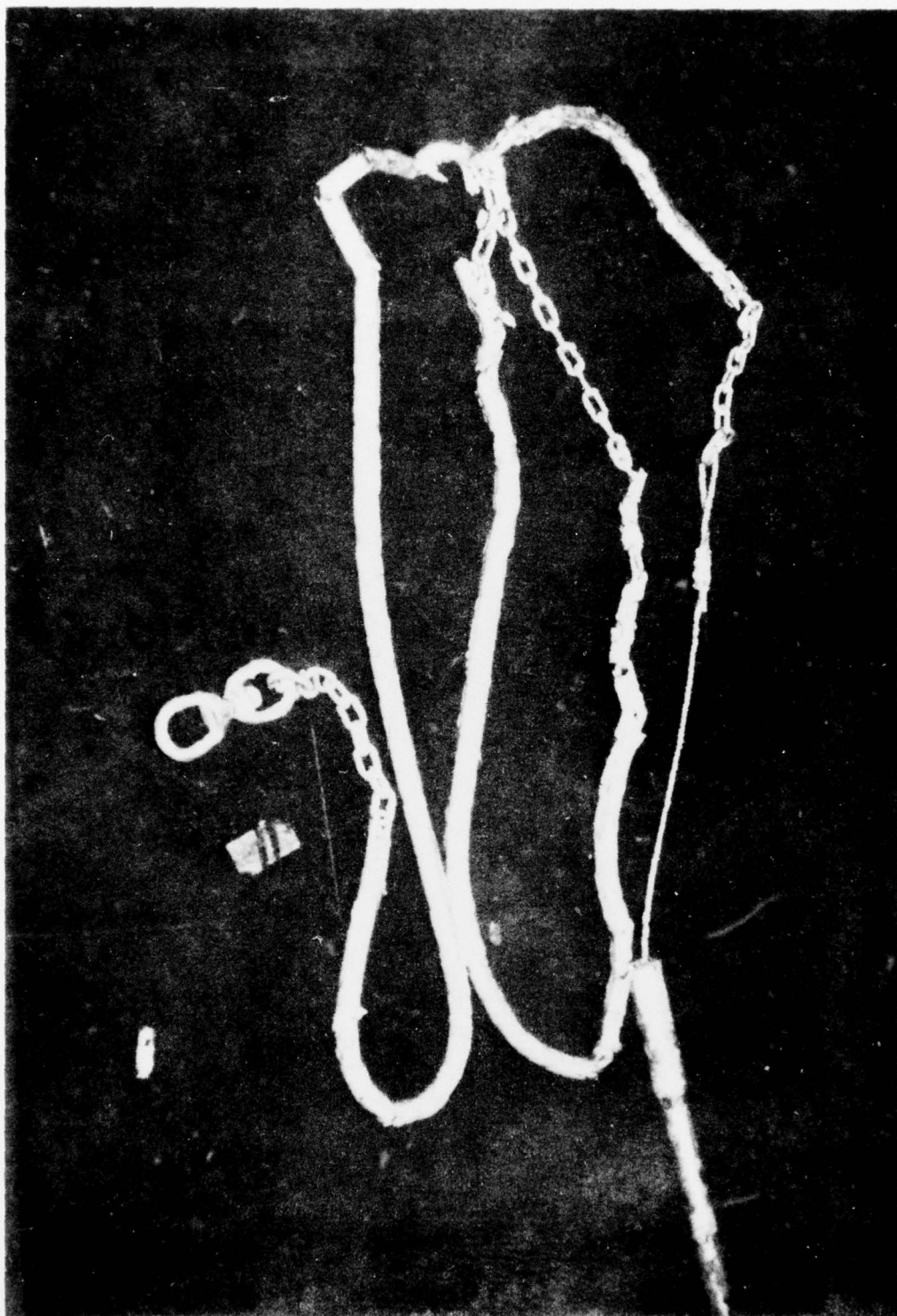

Figure 31. Chain mooring with "elastic band" (after firing).

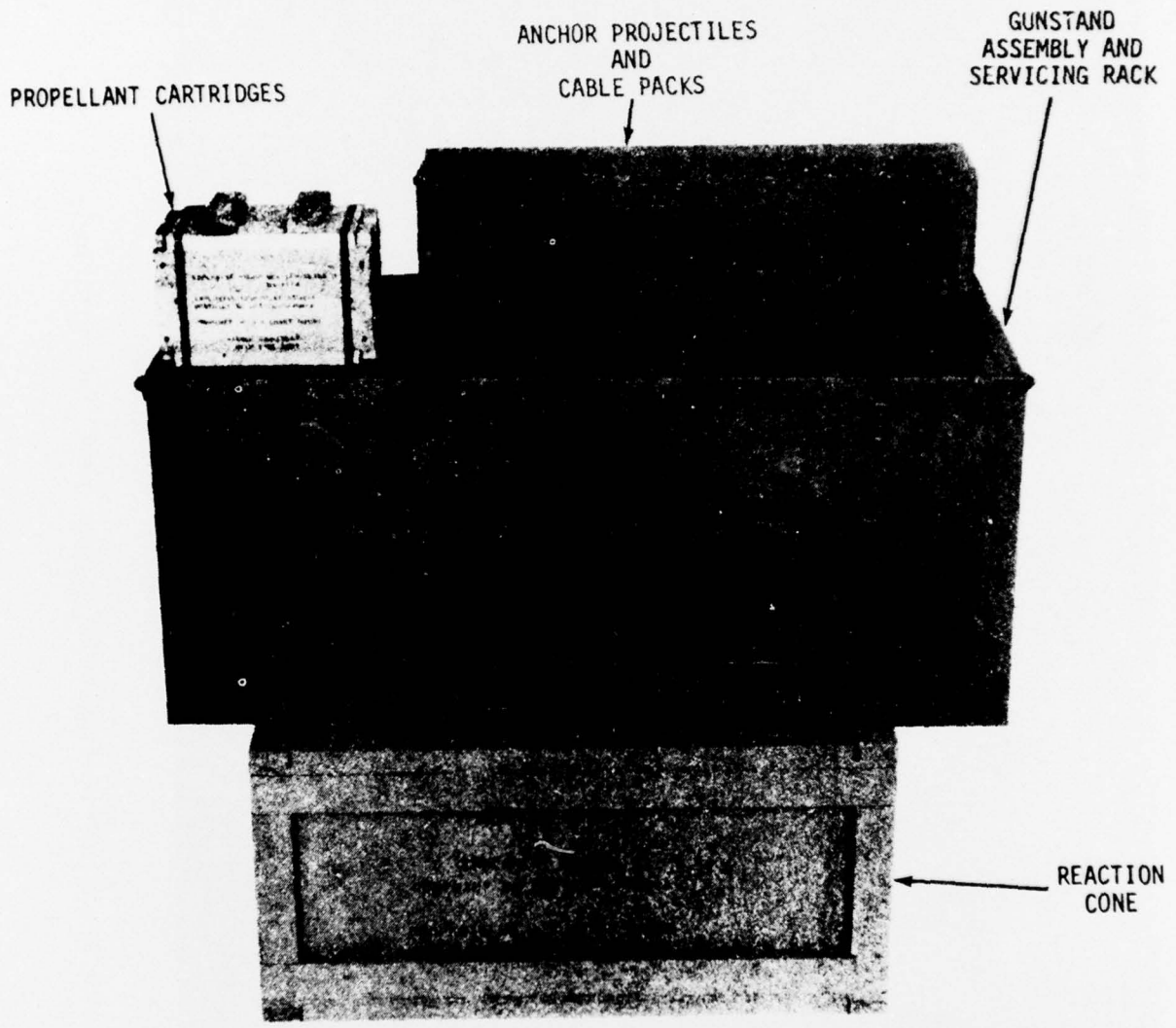

Figure 32. Shipping and storage containers.

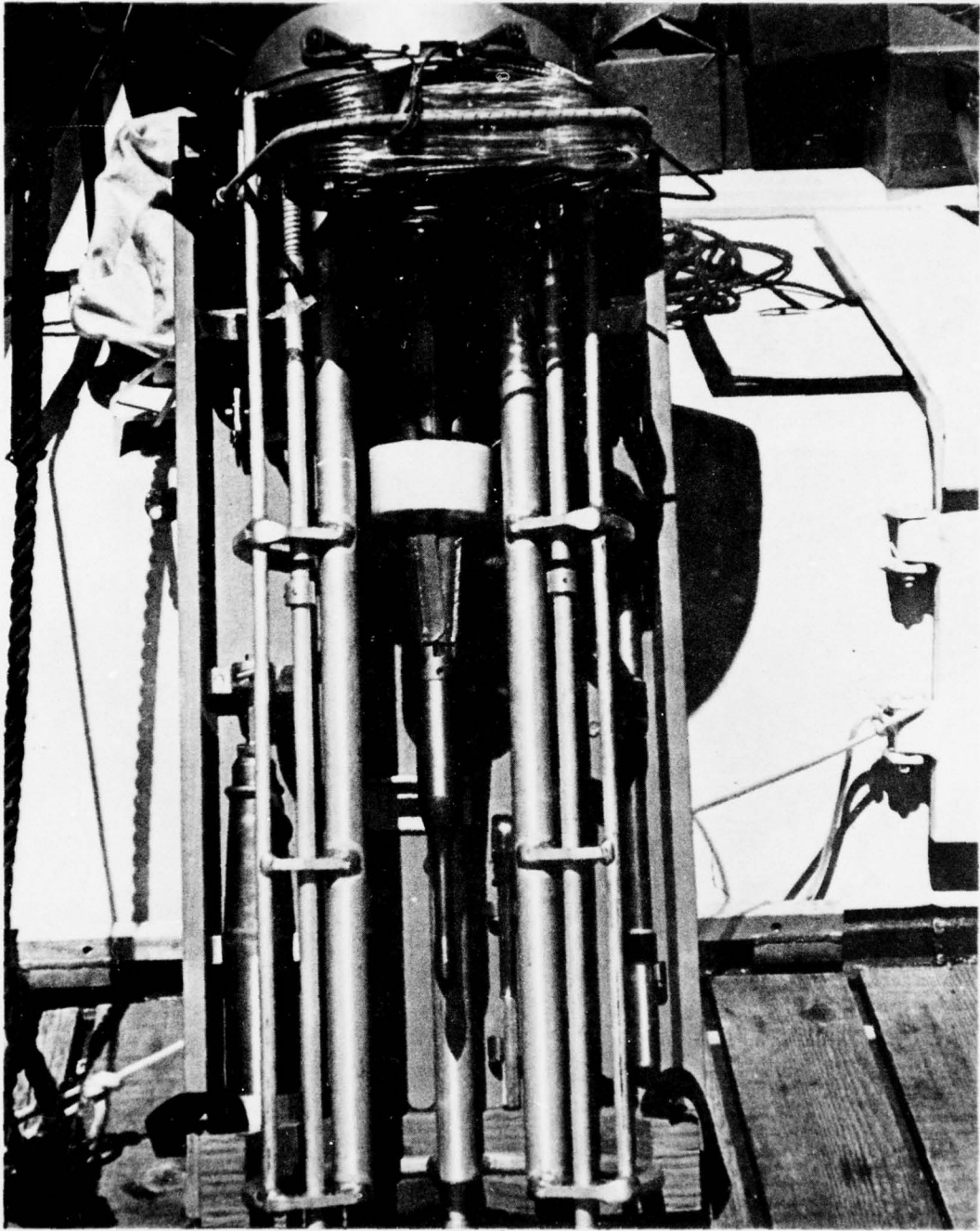

Figure 33. Servicing rack.

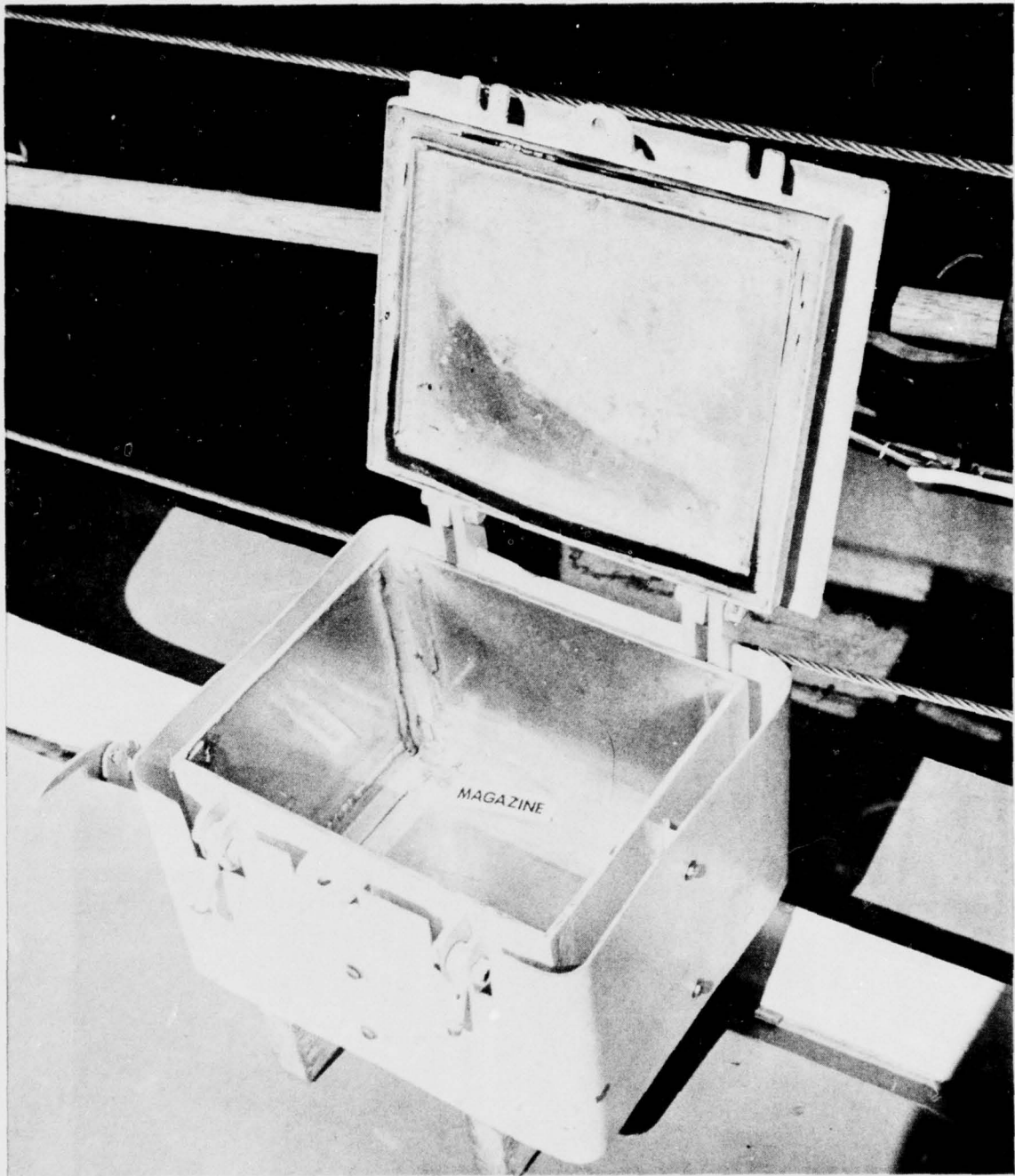

Figure 34. Shipboard magazine.

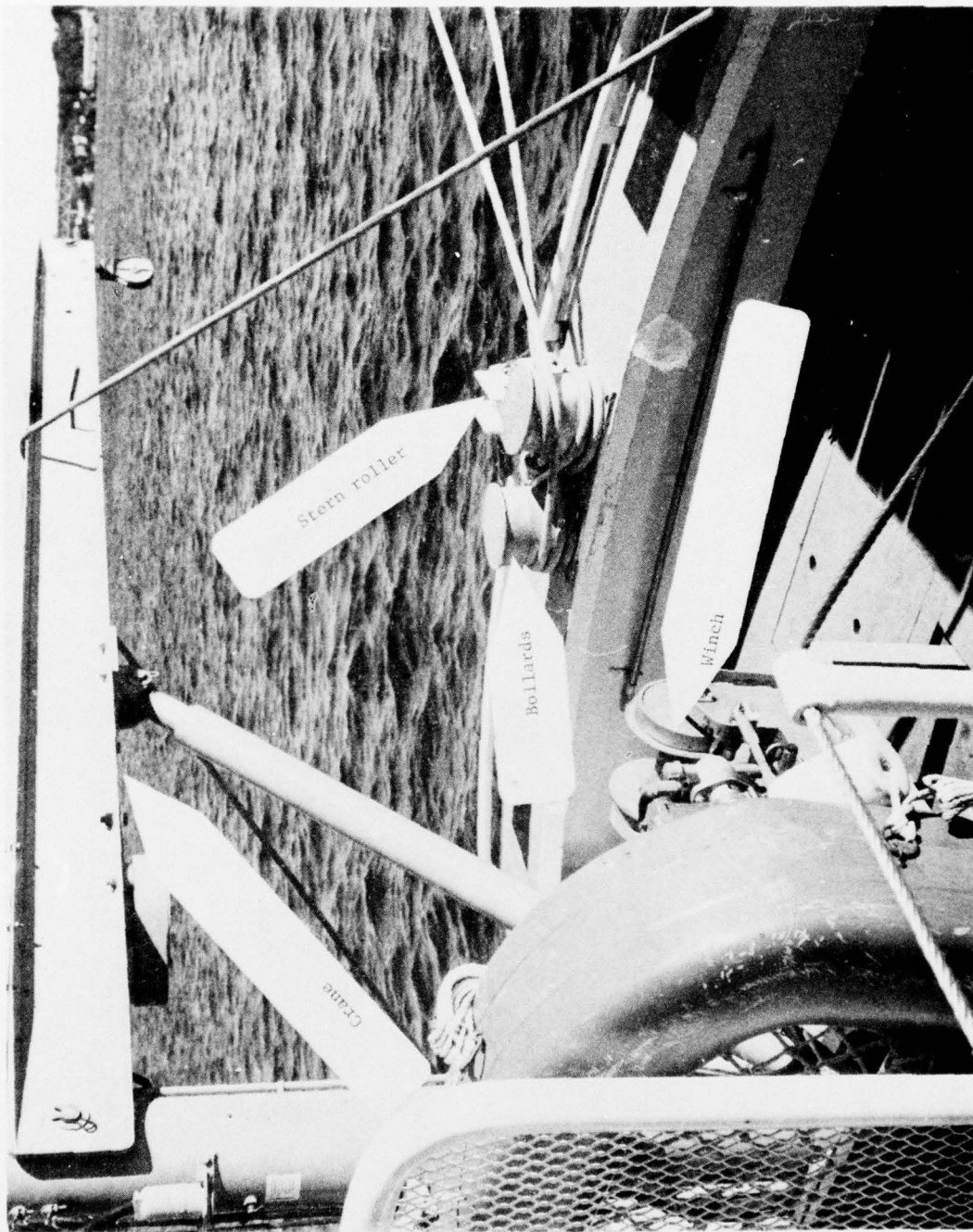

Figure 35. Handling equipment.



Figure 36. Cartridge.



Figure 37. Plate penetration.

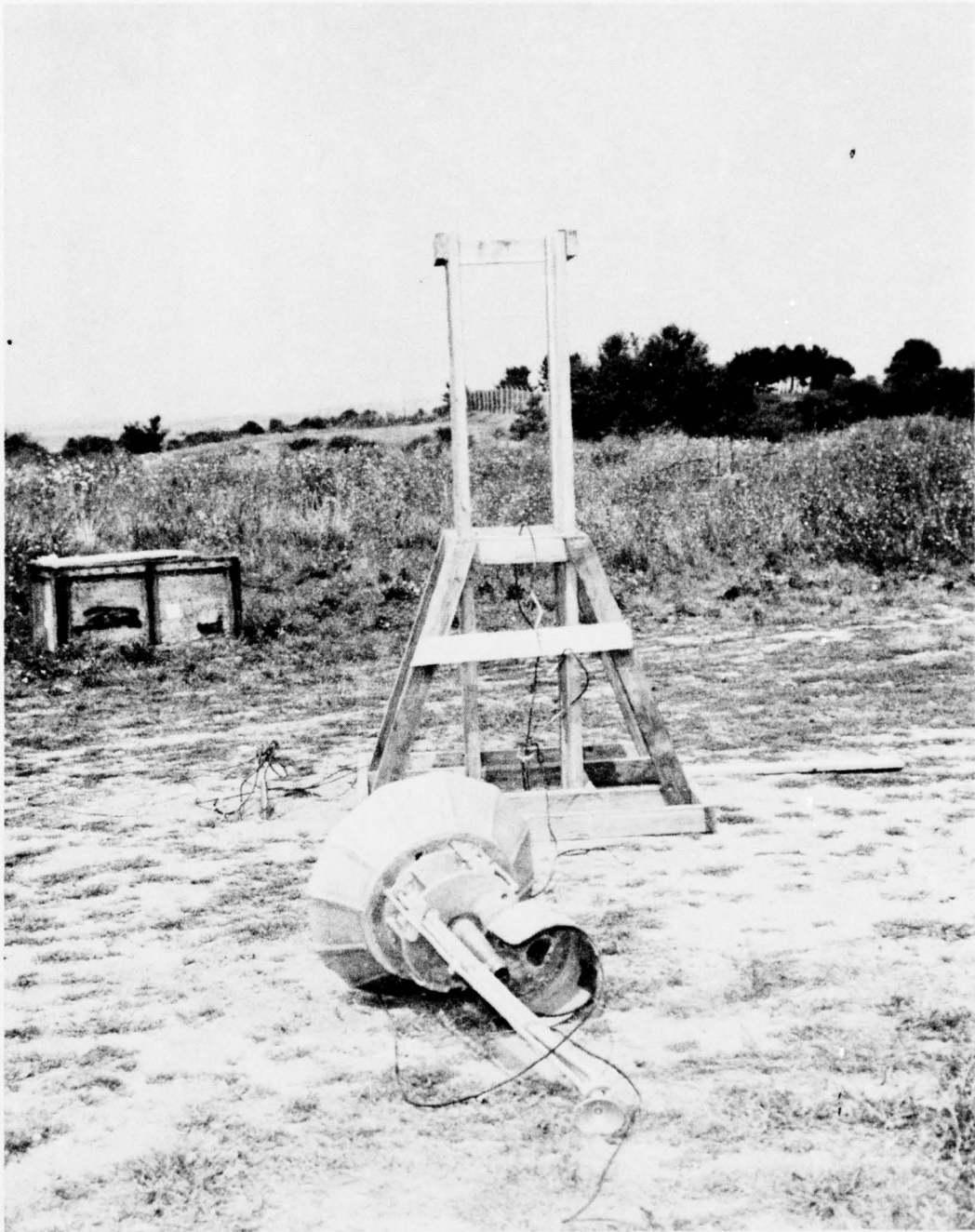

Figure 38. Fallen gunstand.

APPENDIX A

SAFETY PRECAUTIONS

A.1 General - The Explosive Embedment Anchor System, if not handled properly and with proper precautions, can be an extremely dangerous device to all personnel within range of it. This range can be quite far. For instance, if the projectile for some reason were fired in a straight-up direction with a muzzle velocity of 500 feet per second and with a drag coefficient (C_d) of 1, the projectile would attain a height of over 3000 feet. Fired in a horizontal direction it would be extremely dangerous to personnel within one-half to one mile away. Therefore, it is imperative that the gunstand loaded with a projectile always be pointed downward and that personnel adopt a policy of standing off to one side of the potential bounce path of the projectile while working on the boat.

A.2 Safety Procedures

A.1.1 Summary of Important Safety Rules - The following rules should be observed by all personnel involved in operating the EEA.

- a. Never stand in front of the gun barrel muzzle even though not loaded.
- b. Never stand directly in line with the potential bounce path of the projectile.
- c. Never install a cartridge unless actually loading the gunstand, in which case, the procedure is ALWAYS install -- first the projectile, second the cartridge, and third the firing mechanism.

WARNING

If this procedure is not followed, a serious accident could happen. For instance, if a cartridge is inserted first, the firing mechanism screwed into the breech block part way (but not yet reset), and someone snaps the projectile in place and it overshoots slightly, the projectile may ram the cartridge up into the protruding pin of the firing mechanism causing the pin to detonate the cartridge. The resultant muzzle blast of the projectile and gunstand displacement could blind, blow off both hands, or may be lethal to personnel involved.

d. Never install the firing mechanism in the breech block unless actually loading the gunstand. For example, don't screw the firing mechanism into the breech block just to store it until ready to use it. Always store it in the mounting provided on the servicing rack.

e. Never, under any circumstances, install the firing mechanism unless the firing mechanism has been reset and the firing pin is not protruding out the bottom of the firing mechanism.

f. Never reset the firing mechanism while it is still in the gunstand. Always reset the firing mechanism while it is secured to the servicing rack.

g. Never load the gunstand unless it has been secured into the servicing rack. This assures a safer, stable unit to work on in the presence of boat oscillations.

A.3 Hang-Fire Situations

A.2.1 Definitions and Causes - If the gunstand has been deployed to the bottom and has failed to fire, it must be immediately handled as a hang-fire situation. (THE LOADED GUNSTAND MUST BE HANDLED AS IF IT WERE GOING TO FIRE AT ANY MOMENT.) Possible causes for a hang-fire situation are given as follows:

a. In sufficient water depth to arm hydrostatic lock-up on firing mechanism or gunstand.

b. Pin is sheared which connects the firing mechanism trigger to sear shaft.

c. Firing mechanism reset shaft not properly seated in firing mechanism and extending over gunstand triggering ring restricting the trigger ring from pushing up on the trigger.

d. Firing mechanism not seated all the way against propellant cartridge.

e. Firing mechanism not reset (cocked).

f. Damaged firing mechanism. Identified by:

1. Sear lock-up arm dragging on the hydrostatic lock.

2. Force required to arm hydrostatic lock too high (dragging problem).

3. Damaged internally by high pressure gas, corrosion, or abnormal wear.

4. Pin which connects trigger arm to sear is sheared.

g. Water in firing mechanism due to damaged seals or from entry through the firing pin hole prior to installation on the gunstand.

NOTE

An appreciable amount of water from a leak may keep the hydrostatic lock from arming the firing mechanism no matter how deep the unit may be lowered.

h. Gunstand hydrostatic lock not arming due to:

1. Damaged diaphragm letting in water.

2. Internal damage or corrosion in plunger causing it to lock in the extended position.

i. Gunstand did not contact bottom.

j. Bottom sensing mechanism on gunstand not free to move in gunstand due to foreign material or damage.

k. Propellant cartridge not installed.

A.3 Handling and Safety Procedures - For hang-fire situations, observe the following:

A.3.1 Keep the gunstand suspended overboard with gunstand near a vertical position and the anchor pointed toward the water. Personnel must stay at least six feet away from the gunstand.

A.3.2 Prevent excessive swinging as much as possible by securing the gunstand with lines or other means. Personnel must continue to remain at least six feet away from the gunstand.

A.3.3 Keep the gunstand suspended overboard for the period of time required by U. S. Coast Guard procedures for misfire handling before attempting to inspect the gunstand to determine the cause of failure to fire. After the required time (cock-off time) has elapsed, proceed with the following procedures in the order listed:

a. Keep gunstand in vertical attitude (over water).

b. Rotate gunstand (with boat hook) until open side is toward you, handle gently, do not jar or bolt.

c. Reach in through open side of gunstand with boat hook or other long tool and pull form collar down and off of anchor. The anchor should fall out of gun barrel, if not, remove it carefully by slightly opening flukes to release them from anchor retainer. Disconnect and remove the cable packs.

CAUTION

Continue to handle with care, gunstand is still dangerous. If the unit should fire, the bore seal will exit the gun barrel like a bullet. (See WARNING note, Section A.2.)

d. Visually inspect gunstand, gunstand hydrostatic lock, and firing mechanism for cause of failure to fire. Govern your procedures according to your findings.

e. Carefully remove firing mechanism.

f. Remove propellant cartridge, use bore cleaner knock out
rod if necessary.

g. Do not reuse propellant cartridge if primer has been dented
by firing pin.

h. If misfire has not been determined yet, continue checkout
of gunstand and firing mechanism for cause of failure to fire. Refer to list
of possible causes in paragraph A.1.1 as an aid.

i. The gunstand should not be reloaded until cause of failure
is determined and corrected.