

AD-A031522

Dup  
A031522

SARKI-RLP-L

RIA-76-U607

USADACS Technical Library  
5 0712 01010315 7

AD

BRL MR 2674

# BRL

## TECHNICAL LIBRARY

MEMORANDUM REPORT NO. 2674

BLAST LOADING ON MODEL DUMMIES IN  
TWO-ROOM SHELTERS

George A. Coulter

September 1976

Approved for public release; distribution unlimited.

19971009102

DTIC QUALITY INSPECTED 3

USA BALLISTIC RESEARCH LABORATORIES  
ABERDEEN PROVING GROUND, MARYLAND

Destroy this report when it is no longer needed.  
Do not return it to the originator.

Secondary distribution of this report by originating  
or sponsoring activity is prohibited.

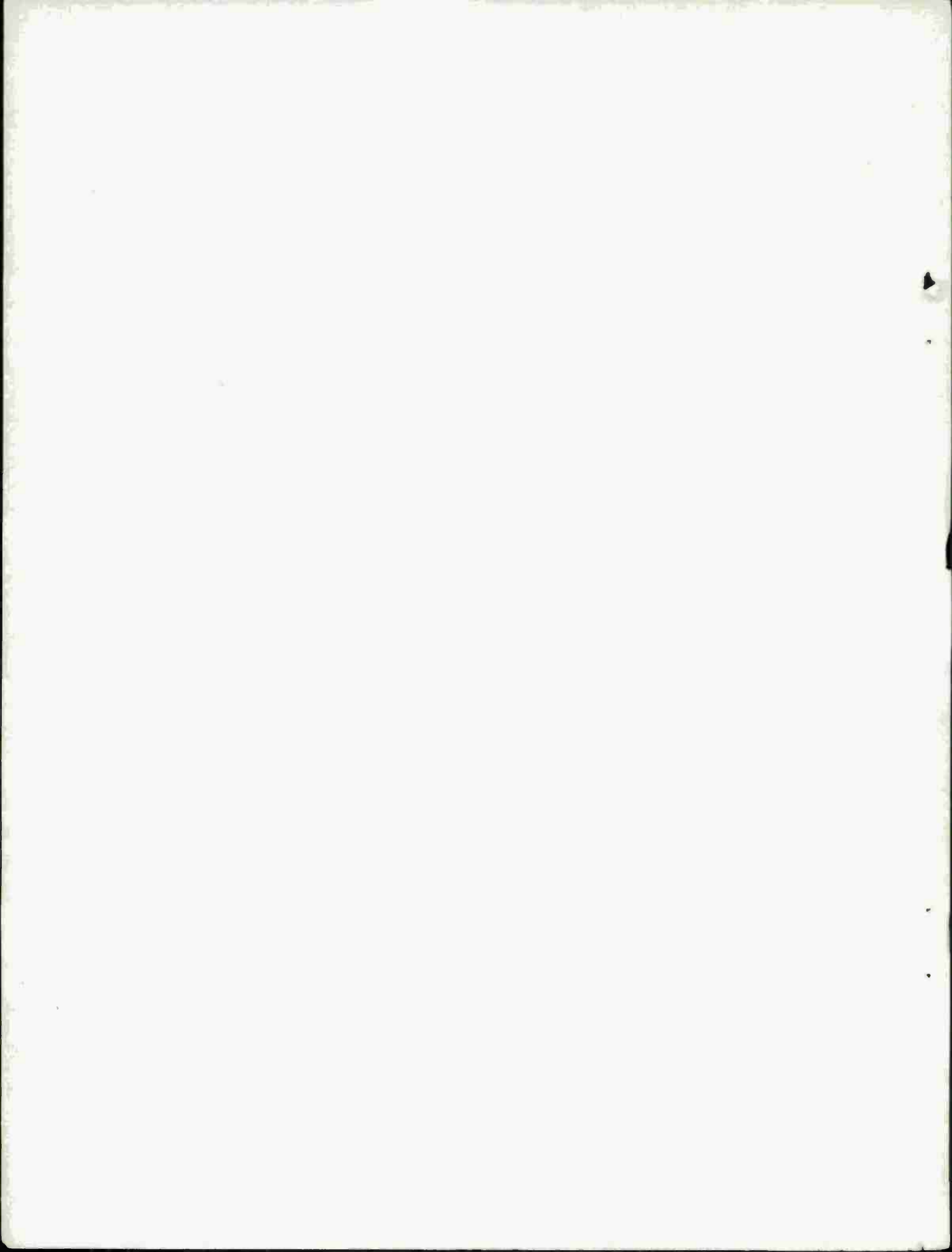
Additional copies of this report may be obtained  
from the National Technical Information Service,  
U.S. Department of Commerce, Springfield, Virginia  
22151.

The findings in this report are not to be construed as  
an official Department of the Army position, unless  
so designated by other authorized documents.

UNCLASSIFIED

SECURITY CLASSIFICATION OF THIS PAGE (When Data Entered)

REPORT DOCUMENTATION PAGE		READ INSTRUCTIONS BEFORE COMPLETING FORM
1. REPORT NUMBER BRL Memorandum Report No. 2674	2. GOVT ACCESSION NO.	3. RECIPIENT'S CATALOG NUMBER
4. TITLE (and Subtitle)  BLAST LOADING ON MODEL DUMMIES IN TWO-ROOM SHELTERS		5. TYPE OF REPORT & PERIOD COVERED  Final
		6. PERFORMING ORG. REPORT NUMBER
7. AUTHOR(s)  George A. Coulter		8. CONTRACT OR GRANT NUMBER(s)
9. PERFORMING ORGANIZATION NAME AND ADDRESS  USA Ballistic Research Laboratories Aberdeen Proving Ground, Maryland 21005		10. PROGRAM ELEMENT, PROJECT, TASK AREA & WORK UNIT NUMBERS Project Order No. DCPA 01-75-C-0285, Work Unit 1123C
11. CONTROLLING OFFICE NAME AND ADDRESS US Army Materiel Development and Readiness Command 5001 Eisenhower Avenue Alexandria, Virginia 22333		12. REPORT DATE September 1976
		13. NUMBER OF PAGES 151
14. MONITORING AGENCY NAME & ADDRESS (if different from Controlling Office) Defense Civil Preparedness Agency Washington, D.C. 20301		15. SECURITY CLASS. (of this report)  UNCLASSIFIED
		15a. DECLASSIFICATION/DOWNGRADING SCHEDULE
16. DISTRIBUTION STATEMENT (of this Report)  Approved for public release: distribution unlimited.		
17. DISTRIBUTION STATEMENT (of the abstract entered in Block 20, if different from Report)		
18. SUPPLEMENTARY NOTES		
19. KEY WORDS (Continue on reverse side if necessary and identify by block number)  Air Flow                      Model Dummies Blast Loading              Translation Velocities Blast Shelter Fill Pressure		
20. ABSTRACT (Continue on reverse side if necessary and identify by block number) (mba) Experimental results obtained from the blast loading of model dummies inside scaled two-room shelters are given for 20 and 49% open front walls. The translational velocities of the model dummies are given as a function of shelter configuration and the experimental overpressure levels of 3 - 10 psi. The results obtained are scaled up to give predictions for full size shelters.		



## SUMMARY

### I. INTRODUCTION

The work reported here is a portion of a study requested by the Defense Civil Preparedness Agency under Project Order No. DCPA 01-75-C-0285, Work Unit 1123C entitled, "Blast Loading in Existing Structures."

An experiment is described in which shock waves enter a two-room shelter model. The resulting motion upon model dummies during the shock-filling process is shown by means of high speed photographs.

### II. EXPERIMENT

A 1/12th scale two-room shelter model was exposed at the end of the Ballistic Research Laboratories' 24-Inch Shock Tube. Pressure transducers before the model and in the two rooms were used to record pressure-time histories of the input and fill pressures during exposure to the shock wave.

Motion of two model dummies in the front room was observed by means of high speed photography. Measurements of average translational velocities were made as a function of the front entrance area and input pressure. Entrances of 49 and 20% open were exposed in the 3 - 10 psi pressure range.

### III. RESULTS AND CONCLUSIONS

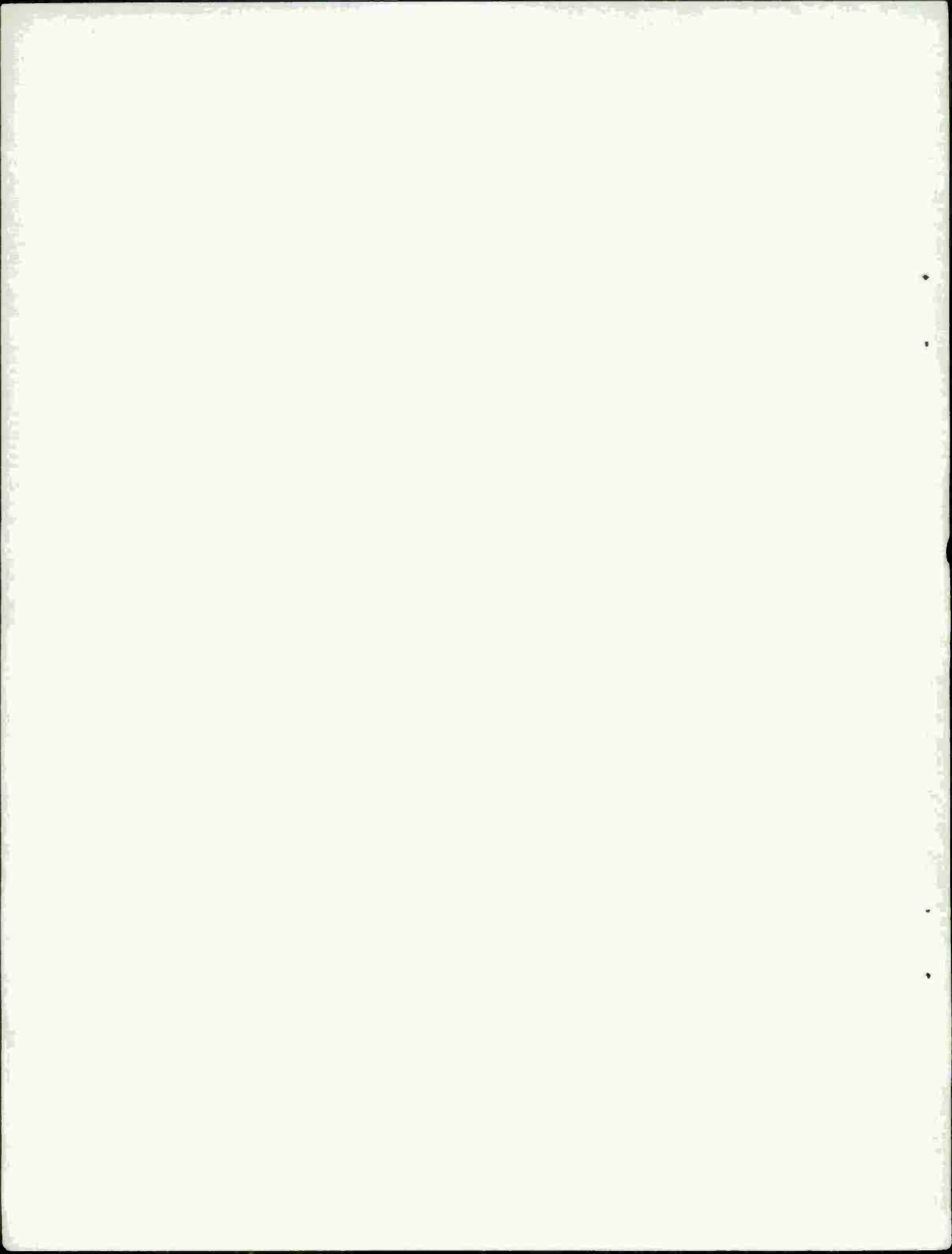
Fill pressures of about equal to the reflected outside model pressure were measured inside the rooms. The shock tube had a length such that for the model volume to entrance area ratio chosen, the rooms would fill during the shock wave's flat portion of duration.

Translational velocities of the dummies were found to vary as a function of input pressure level, location within the room, and entrance area. Predicted pressure filling and translation parameters are given for full size shelters by scaling up the experiment to full size.



## TABLE OF CONTENTS

	Page
LIST OF ILLUSTRATIONS . . . . .	5
LIST OF TABLES . . . . .	9
I. INTRODUCTION . . . . .	13
II. EXPERIMENT . . . . .	13
III. RESULTS . . . . .	17
A. Pressure-Time Traces . . . . .	17
B. Motion of the Model Dummies . . . . .	17
C. Tables of Data . . . . .	29
IV. COMPUTER CODE PREDICTIONS . . . . .	29
A. Fill-Time Predictions . . . . .	36
B. Translation Parameters . . . . .	36
V. SUMMARY AND CONCLUSIONS . . . . .	48
A. Summary of Experiment . . . . .	48
B. Predictions for Full Size Shelters . . . . .	48
REFERENCES . . . . .	62
APPENDICES . . . . .	63
A. High Speed Photographs . . . . .	63
B. Tables of Predicted Fill Parameters for Model . . . . .	85
C. Tables of Predicted Fill Parameters for Full Size Shelters . . . . .	97
D. Predicted Translation Parameters for Experimental Model . . . . .	111
E. Predicted Translation Parameters for Full Size Shelter . . . . .	131
DISTRIBUTION LIST . . . . .	147



## LIST OF ILLUSTRATIONS

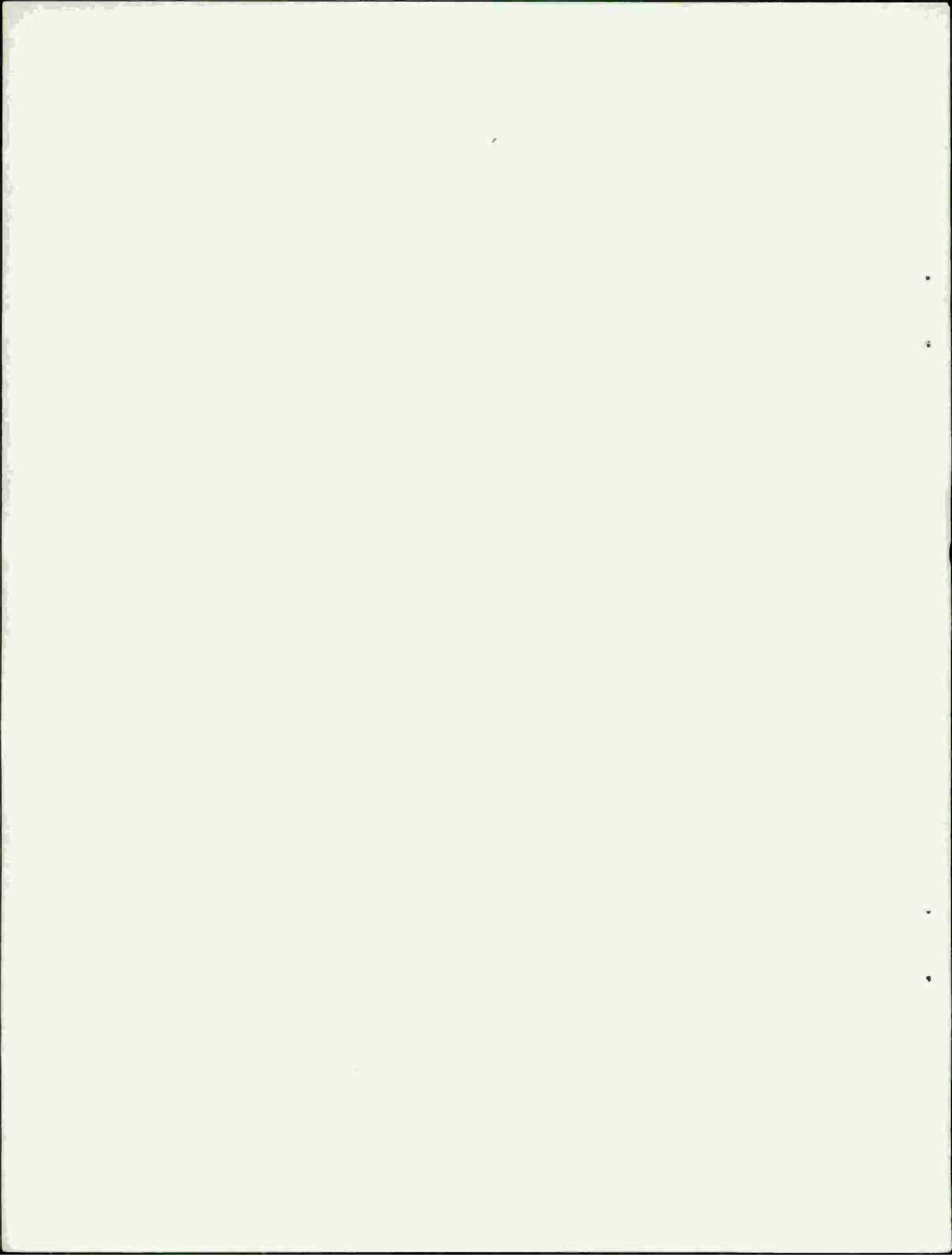
Figure	Page
1. Two-Room Model Shelter . . . . .	14
2. Grid Lines Used for High Speed Photography . . . . .	16
3. Pressure-Time Traces - Case I, 3.7 psi . . . . .	18
4. Pressure-Time Traces - Case I, 7.4 psi . . . . .	19
5. Pressure-Time Traces - Case I, 11.4 psi . . . . .	20
6. Pressure-Time Traces - Case II, 3.7 psi . . . . .	21
7. Pressure-Time Traces - Case II, 10.9 psi . . . . .	22
8. Pressure-Time Traces - Case III, 3.3 psi . . . . .	23
9. Pressure-Time Traces - Case III, 7.3 psi . . . . .	24
10. Pressure-Time Traces - Case III, 10.6 psi . . . . .	25
11. 49% Open Front-Prone on 6-inch Line, 7.5 psi . . . . .	26
12. 49% Open Front-Standing on 6-inch Line, 7.4 psi . . . . .	27
13. Pressure-Fill Predictions - 49% Opening, 3.6 psi . . . . .	39
14. Pressure-Fill Predictions - 49% Opening, 7.5 psi . . . . .	40
15. Pressure-Fill Predictions - 49% Opening, 10.9 psi . . . . .	41
16. Pressure-Fill Predictions - 20% Opening, 3.5 psi . . . . .	42
17. Pressure-Fill Predictions - 20% Opening, 7.5 psi . . . . .	43
18. Pressure-Fill Predictions - 20% Opening, 10.9 psi . . . . .	44
19. Translational Velocity of Model Dummy as a Function of Location on Floor . . . . .	49
20. Fill Predictions for Full Size Shelter - 49% Opening, 3 psi . . . . .	51
21. Fill Predictions for Full Size Shelter - 49% Opening, 7 psi . . . . .	52

## LIST OF ILLUSTRATIONS

Figure	Page
22. Fill Predictions for Full Size Shelter - 49% Opening, 10 psi . . . . .	53
23. Fill Predictions for Full Size Shelter - 20% Opening, 3 psi . . . . .	54
24. Fill Predictions for Full Size Shelter - 20% Opening, 7 psi . . . . .	55
25. Fill Predictions for Full Size Shelter - 20% Opening, 10 psi . . . . .	56
26. Predicted Translational Velocity for a 168-lb Man Prone at Entrance . . . . .	60
27. Predicted Translational Velocity for a 168-lb Man Standing at Entrance . . . . .	61
A-1. 49% Open Front-Prone on 6-inch Line, 10.4 psi . . . . .	65
A-2. 49% Open Front-Prone on 12-inch Line, 7.5 psi . . . . .	66
A-3. 49% Open Front-Prone on 12-inch Line, 11.1 psi . . . . .	67
A-4. 49% Open Front-Standing on 6-inch Line, 3.6 psi . . . . .	68
A-5. 49% Open Front-Standing on 12-inch Line, 3.5 psi . . . . .	69
A-6. 49% Open Front-Standing on 12-inch Line, 7.7 psi . . . . .	70
A-7. 49% Open Front-Standing on 12-inch Line, 11.6 psi . . . . .	71
A-8. 20% Open Front-Prone on 6-inch Line, 3.5 psi . . . . .	73
A-9. 20% Open Front-Prone on 6-inch Line, 11.4 psi . . . . .	74
A-10. 20% Open Front-Prone on 12-inch Line, 11.1 psi . . . . .	75
A-11. 20% Open Front-Standing on 6-inch Line, 3.4 psi . . . . .	76
A-12. 20% Open Front-Standing on 6-inch Line, 10.6 psi . . . . .	77
A-13. 20% Open Front-Standing on 12-inch Line, 11.1 psi . . . . .	78
A-14. 20% Open Front-Standing on 18-inch Line, 3.7 psi . . . . .	79

LIST OF ILLUSTRATIONS

Figure	Page
A-15. 20% Open Front-Standing on 18-inch Line, 10.6 psi . . . . .	80 2
A-16. 20% Open Front - 47% Open Back-Prone on 12-inch Line, 7.3 psi . . . . .	81 1
A-17. 20% Open Front - 47% Open Back-Prone on 12-inch Line, 10.6 psi . . . . .	82 1
A-18. 20% Open Front - 47% Open Back-Standing on 12-inch Line, 3.5 psi . . . . .	83 1
A-19. 20% Open Front - 47% Open Back-Standing on 12-inch Line, 7.6 psi . . . . .	84 1



LIST OF TABLES

Table	Page
I. Data from Case I - 49% Open Front . . . . .	30
II. Data from Case II - 20% Open Front . . . . .	32
III. Data from Case III - 20% Open Front with 47% Open Back . . . . .	34
IV. Comparison of Data from Cases I, II, and III . . . . .	35
V. Fill-Time Prediction - 49% Open, 7.5 psi - Front Room . . . . .	37
VI. Fill-Time Prediction - 49% Open, 7.5 psi - Rear Room . . . . .	38
VII. Predicted Translation Parameters - Prone Position at Entrance - 49% Open, 7.5 psi . . . . .	45
VIII. Predicted Translation Parameters - Standing Position at Entrance - 49% Open, 7.5 psi . . . . .	46
IX. Summary of Model and Shelter Parameters . . . . .	50
X. Predicted Translation Parameters - Prone at Entrance - 49% Open, 1-MT, 7 psi . . . . .	57
XI. Predicted Translation Parameters - Standing at Entrance - 49% Open, 1-MT, 7 psi . . . . .	58
B-I. Fill-Time Prediction - 49% Open, 3.6 psi - Front Room . . . . .	87
B-II. Fill-Time Prediction - 49% Open, 3.6 psi - Rear Room . . . . .	88
B-III. Fill-Time Prediction - 49% Open, 10.9 psi - Front Room . . . . .	89
B-IV. Fill-Time Prediction - 49% Open, 10.9 psi - Rear Room . . . . .	90
B-V. Fill-Time Prediction - 20% Open, 3.6 psi - Front Room . . . . .	91
B-VI. Fill Time Prediction - 20% Open, 3.6 psi - Rear Room . . . . .	92

LIST OF TABLES

Table		Page
B-VII.	Fill-Time Prediction - 20% Open, 7.5 psi - Front Room . . . . .	93
B-VIII.	Fill-Time Prediction - 20% Open, 7.5 psi - Rear Room . . . . .	94
B-IX.	Fill-Time Prediction - 20% Open, 10.9 psi - Front Room . . . . .	95
B-X.	Fill-Time Prediction - 20% Open, 10.9 psi - Rear Room . . . . .	96
C-I.	Fill-Time Prediction - 49% Open, 3 psi - Front Room . . . . .	99
C-II.	Fill-Time Prediction - 49% Open, 3 psi - Both Rooms . . . . .	100
C-III.	Fill-Time Prediction - 49% Open, 7 psi - Front Room . . . . .	101
C-IV.	Fill-Time Prediction - 49% Open, 7 psi - Both Rooms . . . . .	102
C-V.	Fill-Time Prediction - 49% Open, 10 psi - Front Room . . . . .	103
C-VI.	Fill-Time Prediction - 49% Open, 10 psi - Both Rooms . . . . .	104
C-VII.	Fill-Time Prediction - 20% Open, 3 psi - Front Room . . . . .	105
C-VIII.	Fill-Time Prediction - 20% Open, 3 psi - Both Rooms . . . . .	106
C-IX.	Fill-Time Prediction - 20% Open, 7 psi - Front Room . . . . .	107
C-X.	Fill-Time Prediction - 20% Open, 7 psi - Both Rooms . . . . .	108
C-XI.	Fill-Time Prediction - 20% Open, 10 psi - Front Room . . . . .	109
C-XII.	Fill-Time Prediction - 20% Open, 10 psi - Both Rooms . . . . .	110

LIST OF TABLES

Table		Page
D-I.	Predicted Translation Parameters - Prone at Entrance - 49% Open, 3.6 psi . . . . .	113
D-II.	Predicted Translation Parameters - Prone at Entrance - 49% Open, 10.9 psi . . . . .	114
D-III.	Predicted Translation Parameters - Prone at Entrance - 20% Open, 3.6 psi . . . . .	115
D-IV.	Predicted Translation Parameters - Prone at Entrance - 20% Open, 7.5 psi . . . . .	117
D-V.	Predicted Translation Parameters - Prone at Entrance - 20% Open, 10.9 psi . . . . .	119
D-VI.	Predicted Translation Parameters - Standing at Entrance - 49% Open, 3.6 psi . . . . .	121
D-VII.	Predicted Translation Parameters - Standing at Entrance - 49% Open, 10.9 psi . . . . .	122
D-VIII.	Predicted Translation Parameters - Standing at Entrance - 20% Open, 3.6 psi . . . . .	124
D-IX.	Predicted Translation Parameters - Standing at Entrance - 20% Open, 7.5 psi . . . . .	126
D-X.	Predicted Translation Parameters - Standing at Entrance - 20% Open, 10.9 psi . . . . .	128
E-I.	Predicted Translation Parameters - Prone at Entrance - 49% Open, 1-MT, 3 psi . . . . .	133
E-II.	Predicted Translation Parameters - Prone at Entrance - 49% Open, 1-MT, 10 psi . . . . .	134
E-III.	Predicted Translation Parameters - Prone at Entrance - 20% Open, 1-MT, 3 psi . . . . .	135
E-IV.	Predicted Translation Parameters - Prone at Entrance - 20% Open, 1-MT, 7 psi . . . . .	136
E-V.	Predicted Translation Parameters - Prone at Entrance - 20% Open, 1-MT, 10 psi . . . . .	137

LIST OF TABLES

Table	Page
E-VI. Predicted Translation Parameters - Standing at Entrance - 49% Open, 1-MT, 3 psi . . . . .	139
E-VII. Predicted Translation Parameters - Standing at Entrance - 49% Open, 1-MT, 10 psi . . . . .	140
E-VIII. Predicted Translation Parameters - Standing at Entrance - 20% Open, 1-MT, 3 psi . . . . .	141
E-IX. Predicted Translation Parameters - Standing at Entrance - 20% Open, 1-MT, 7 psi . . . . .	142
E-X. Predicted Translation Parameters - Standing at Entrance - 20% Open, 1-MT, 10 psi . . . . .	144

## I. INTRODUCTION

The work reported here is a portion of a study requested by the Defense Civil Preparedness Agency under Project Order No. DCPA 01-75-C-0285, Work Unit 1123C entitled "Blast Loading in Existing Structures."

Results of an experiment are described in which shock waves enter a two-room shelter model. The shock-filling process and related interior air flow effect upon model dummies was observed. The translation velocities of the model dummies are measured as a function of room entrance area and the shock pressure level used. See Reference 1 for a similar study for models of basement and mine shelters.

## II. EXPERIMENT

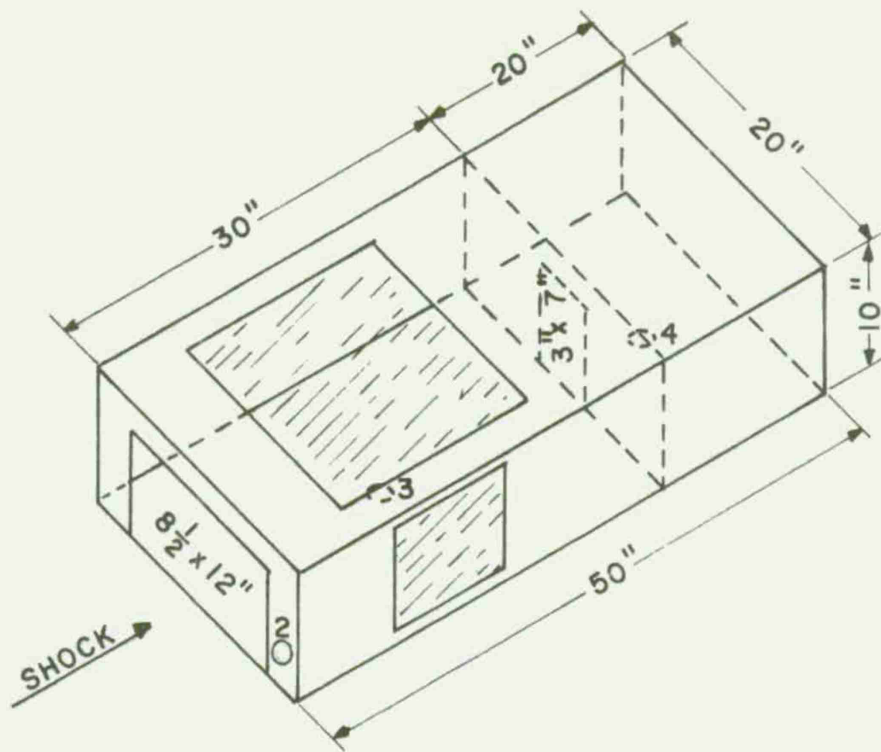
The experiment was designed to model the case in which an incoming blast wave hits a multistory apartment house or office complex. It is assumed that the rooms being studied will receive full reflected blast wave pressure. Rarefactions from nearby rooms are not considered. Windows are assumed to break upon blast arrival. All walls are assumed intact. A 1/12th scale two-room shelter model was built and installed at the end of the BRL 24-inch shock tube. Figure 1 shows the three configurations chosen for the experiment. Entrance areas of 49% and 20% open front were used with the back closed. A third case was considered with a 20% open front and with the back 47% open. All walls were 1/2 inch thick except the front wall which was made 2-1/8 inch thick in order to mate to the shock tube end sections.

Pressure transducers of the ceramic crystal type (Susquehanna Instruments Model ST-2) coupled by BRL impedance converters to transient recorders (Biomation Model 802) were used to record on oscilloscopes (Tektronix Model 565 - with Polaroid cameras) the pressures at the locations shown in Figure 1-D. A high speed HYCAM camera on the left side recorded on film the motion of the model dummies inside the first room.

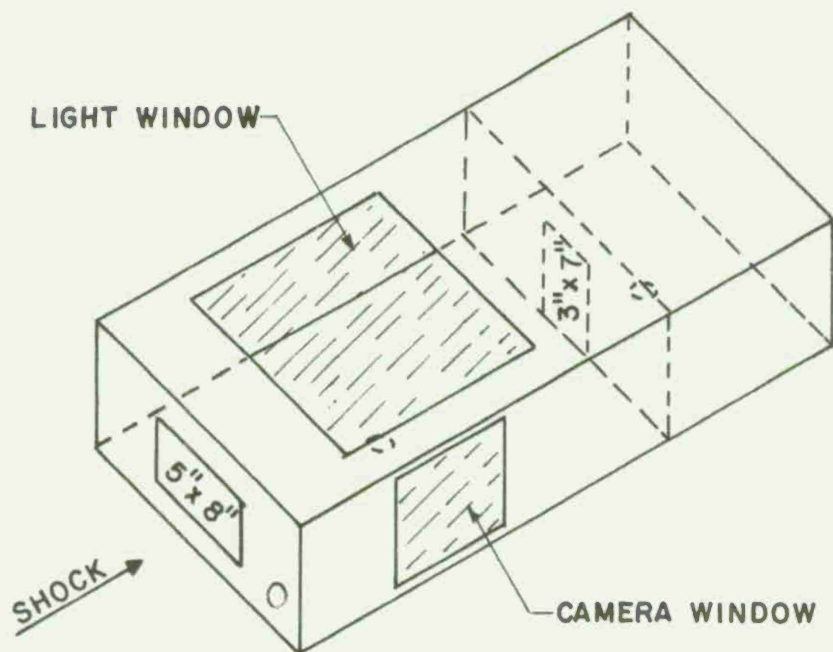
Figure 2 shows the grid floor plan for locating the model dummies before exposure to the shock waves. Shots were taken with the dummies positioned on grids (4, 6); (4, 12); (4, 18); (10, 6); (10, 12); and (10, 18). These are referred to as 6, 12, and 18 inch lines for the two dummies.

The model dummies were made of nylon material pinned together at the joints. All joints were tight enough to allow the model dummies to stand alone. The arms were loose enough to be free to rotate about

<sup>1</sup>George A. Coulter, "Blast Loading in Shelter Models - Basement and Mine Shelters," *Ballistic Research Laboratories Memorandum Report No. 2476, April 1975, AD A070322.*

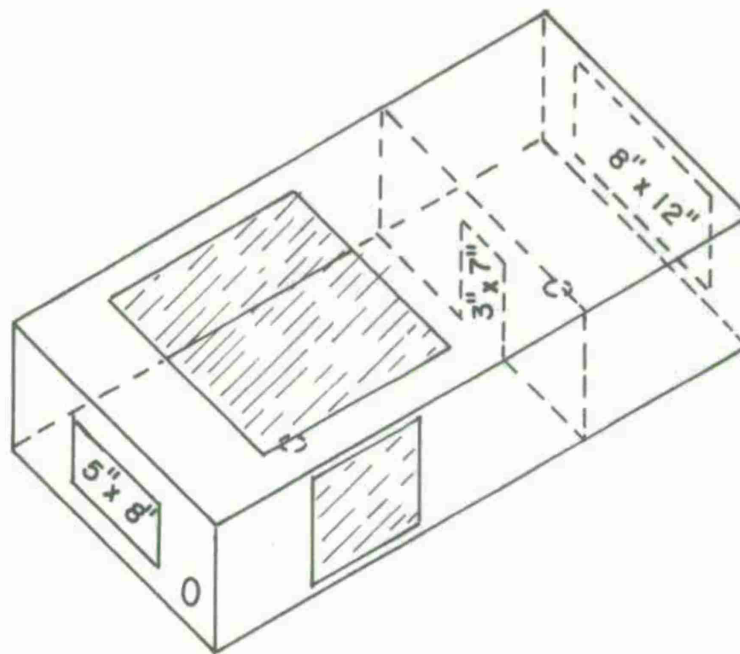


(A) 49% OPEN FRONT-CASE I

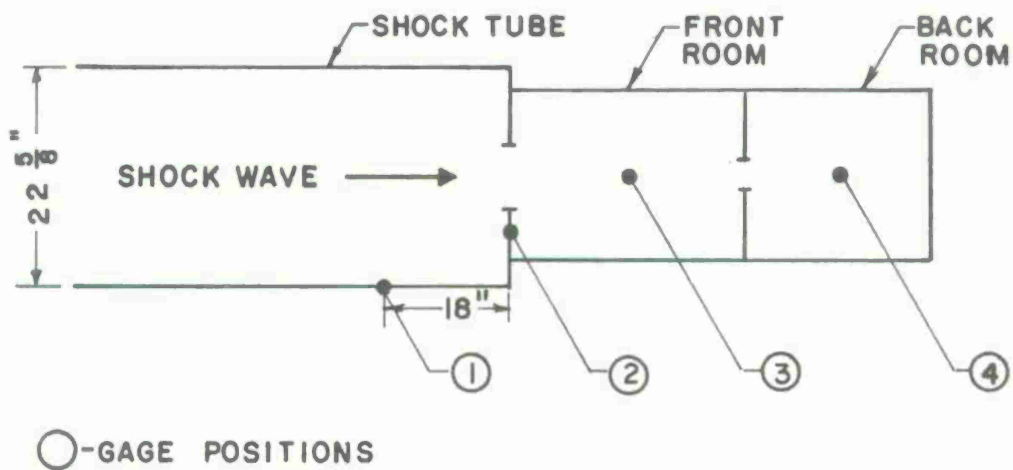


(B) 20% OPEN FRONT-CASE II

Figure 1. Two-Room Model Shelter



(C) 20% OPEN FRONT WITH 47% OPEN BACK-CASE III



(D) MODEL POSITION ON THE SHOCK TUBE

Figure 1. (Cont'd) Two-Room Model Shelter

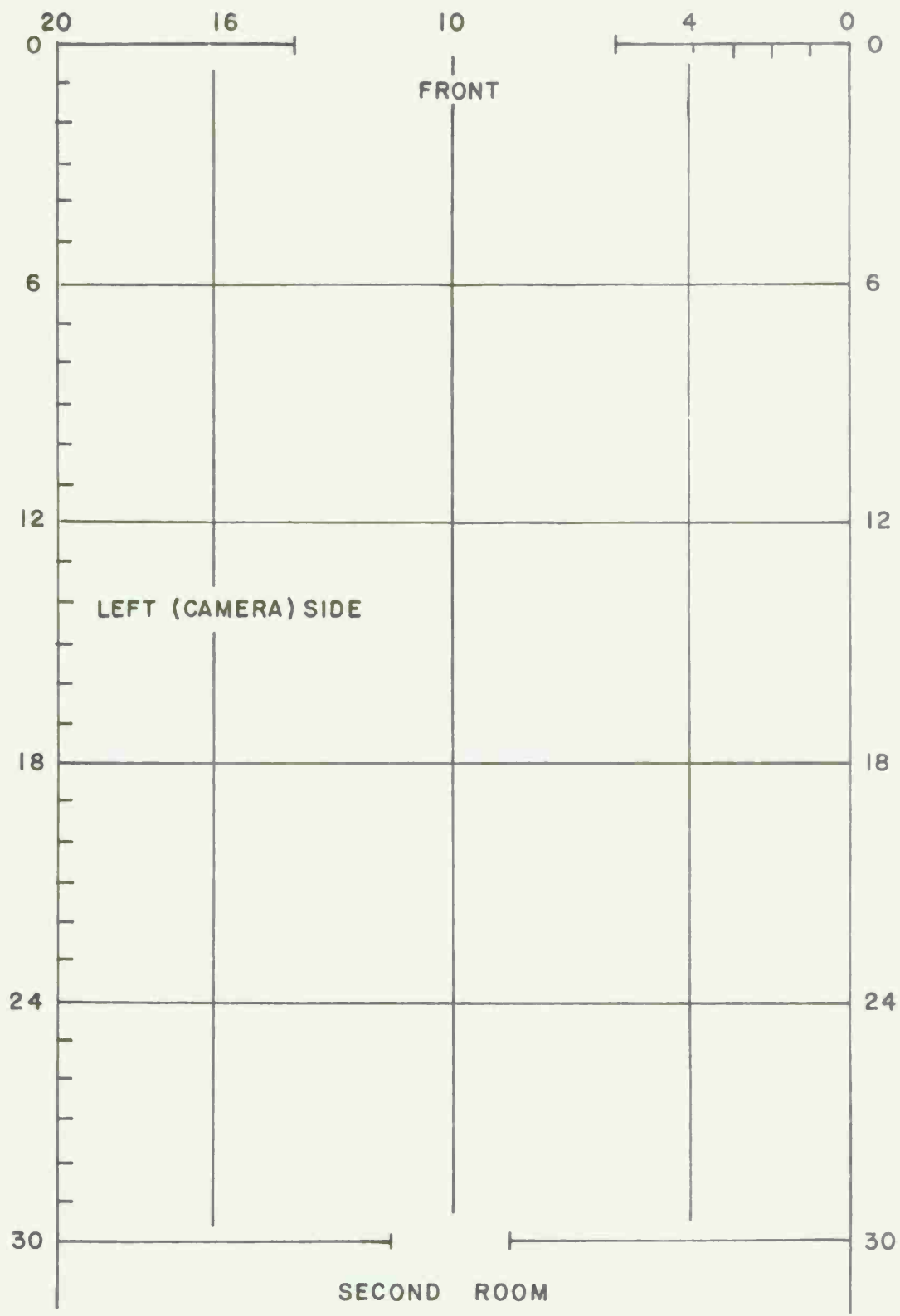


Figure 2. Grid Lines Used for High Speed Photography

the shoulder joints. The weight of each model dummy was about 0.28 lbs (No. 1, 127.9 gm and No. 2, 129.8 gm). Both were about 7.5 inches tall.

Pressure-time traces, high speed pictures, and motion parameters for the model dummies are presented in the Result Section.

### III. RESULTS

The results are presented in three parts. Part A shows the pressure-time traces from the four transducer locations, Part B describes the motion of the model dummies, and Part C lists the results in tabular form.

#### A. Pressure-Time Traces

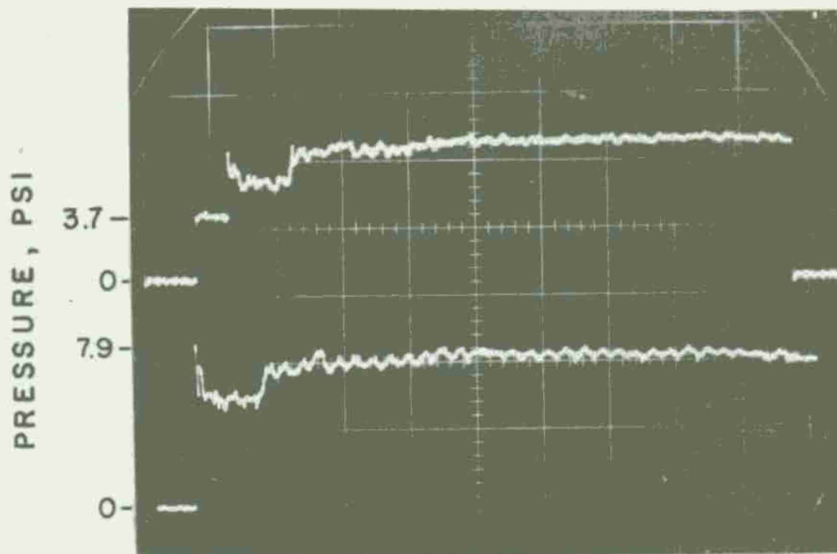
The pressure-time traces are shown in Figures 3 - 10. Case I refers to a front opening of 49%, Case II refers to a front opening of 20%, and Case III refers to a front opening of 20% with a back wall opening of 47%. Positions 1 and 2, the upper picture, give the input and reflected traces respectively as the shock wave hit and reflected back from the outside front of the model. A decay near the front of the reflected trace, Position 2, shows the rarefaction effect as the model was filled with pressure. The discontinuous drop at the rear of the records is trace rewrite, not a pressure drop. Traces from Positions 3 and 4 are shown in the lower picture of each figure. A steady rise of pressure mixed with internal reflected peaks is typical for the fill traces. The greater the front opening, the faster is the fill process.

Figures 9 and 10, Position 4, illustrate the effect of the opening in the back wall. The first room, Position 3, tries to fill but the record from the second room shows a large rarefaction which decayed the pressure below the ambient value. Computer code predictions for the pressure filling are shown in Section IV-A.

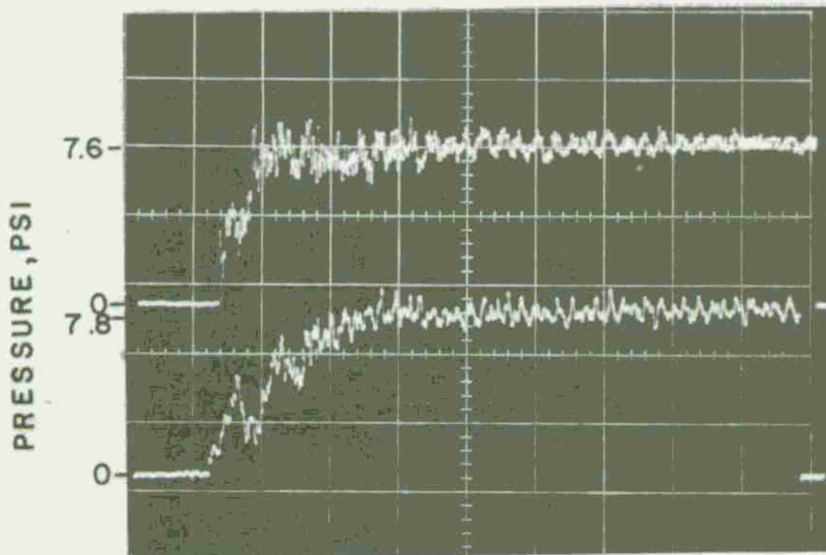
#### B. Motion of the Model Dummies

Figures 11 and 12 are typical of the motion recorded by the high speed camera. Other examples are shown in Appendix A. The pictures were taken from the left side of the first room of the model, with the entrance to the front of the model dummies.

The prone position was recorded with the front of the heads at one of the cross lines. In Figure 11, for example, this is the line 6-inches from the entrance. Dummy No. 2 was located 4-inches from the right side wall and No. 1 was on the entrance center line. Distances from the wall were kept constant for each case but the distances from the front wall were varied; 6, 12, and 18 inches during the experiment. The same locations were also used for the shots when the dummies were standing. The dummies' body axes in this case were aligned over the

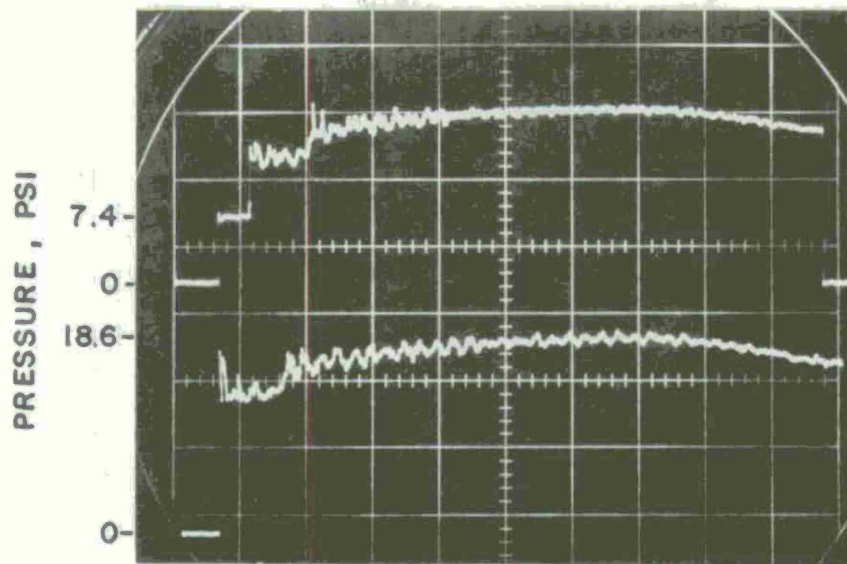


UPPER - INPUT TIME, 5MS/CM  
 LOWER - REFLECTED  
 (A) SHOT 24-75-158  
 POS. 1 & 2

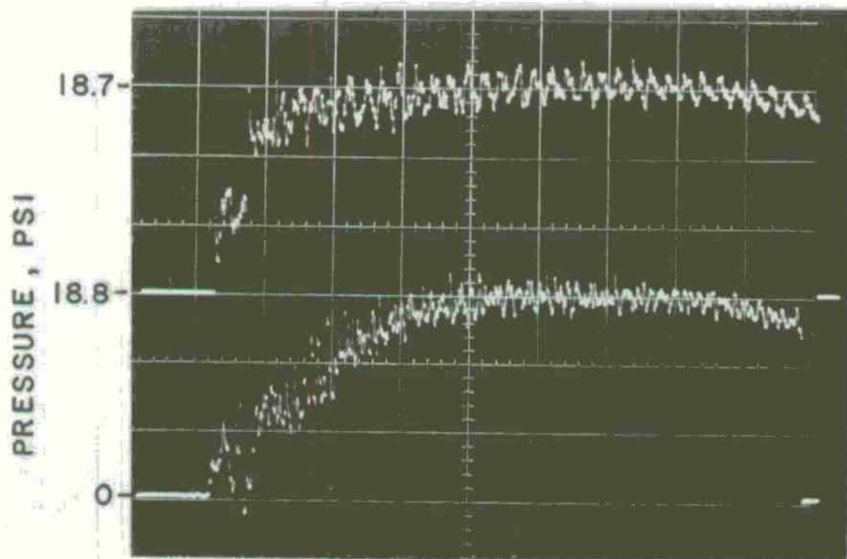


TIME, 5 MS/CM  
 UPPER - FILL, FRONT  
 LOWER - FILL, BACK  
 (B) SHOT 24-75-158  
 POS. 3 & 4

Figure 3. Pressure-Time Traces - Case I, 3.7 psi

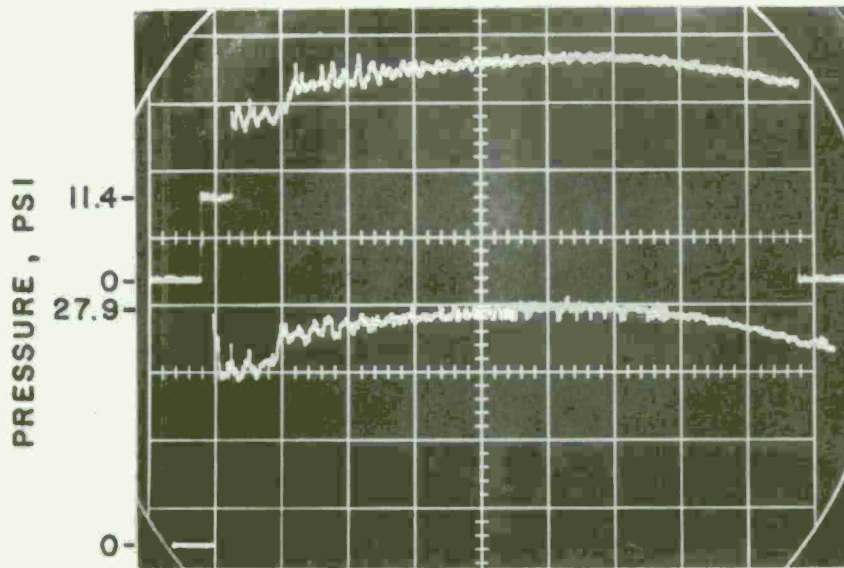


UPPER - INPUT  
 LOWER - REFLECTED  
 (A) SHOT 24-75-150  
 POS. 1 & 2



UPPER - FILL, FRONT  
 LOWER - FILL, REAR  
 (B) SHOT 24-75-150  
 POS. 3 & 4

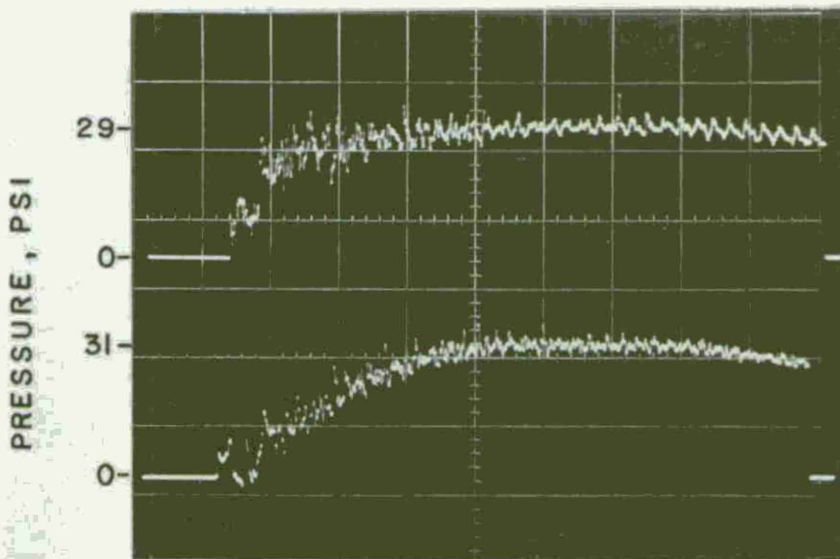
Figure 4. Pressure-Time Traces - Case I, 7.4 psi



TIME, 5 MS/CM

UPPER-INPUT  
LOWER-REFLECTED

(A) SHOT 24-75-159  
POS. 1 & 2

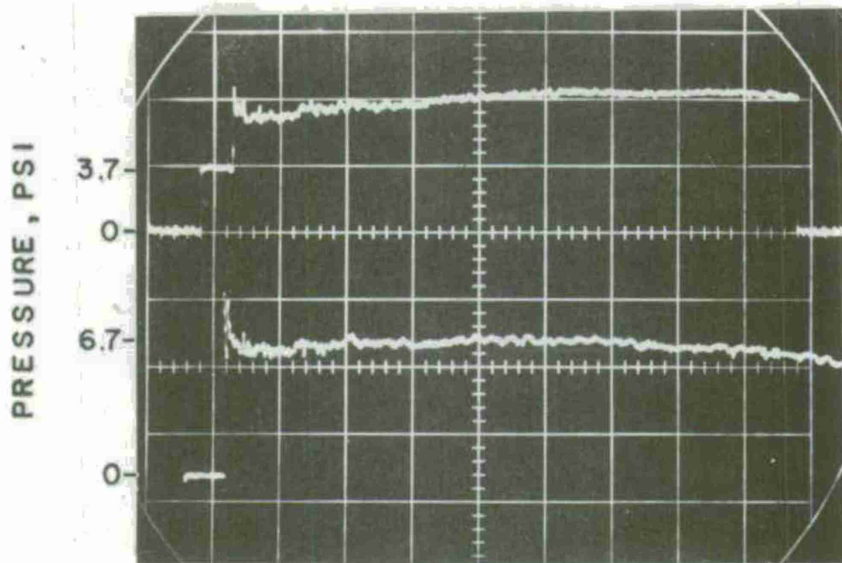


TIME, 5 MS/CM

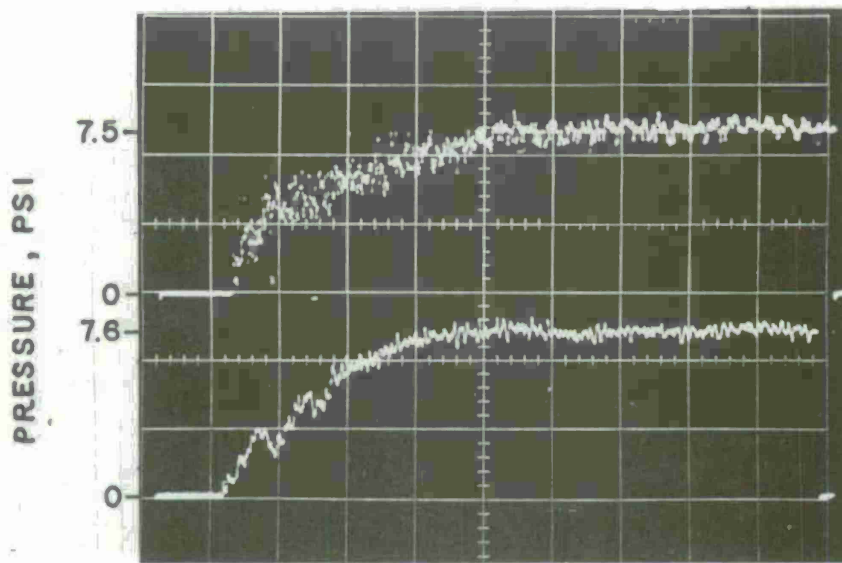
UPPER-FILL FRONT  
LOWER-FILL REAR

(B) SHOT 24-75-159  
POS. 3 & 4

Figure 5. Pressure-Time Traces - Case I, 11.4 psi

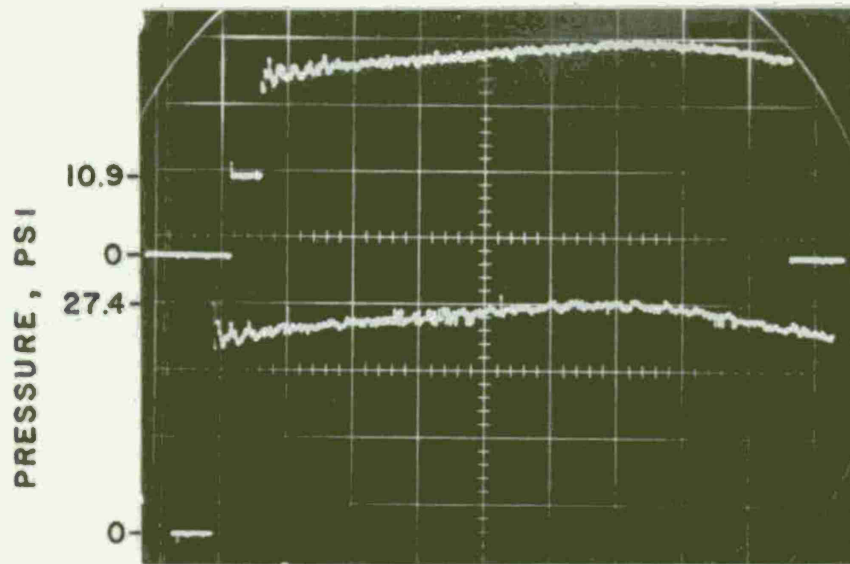


TIME, 5 MS/CM  
 UPPER- INPUT  
 LOWER- REFLECTED  
 (A) SHOT 24-75-162  
 POS. 1 & 2

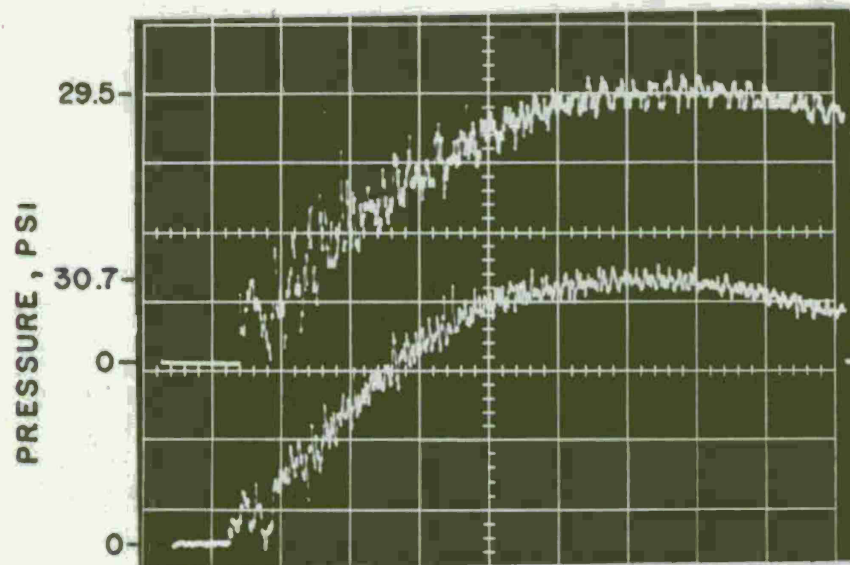


TIME, 5 MS/CM  
 UPPER- FILL FRONT  
 LOWER- FILL REAR  
 (B) SHOT 24-75-162  
 POS. 3 & 4

Figure 6. Pressure-Time Traces - Case II, 3.7 psi

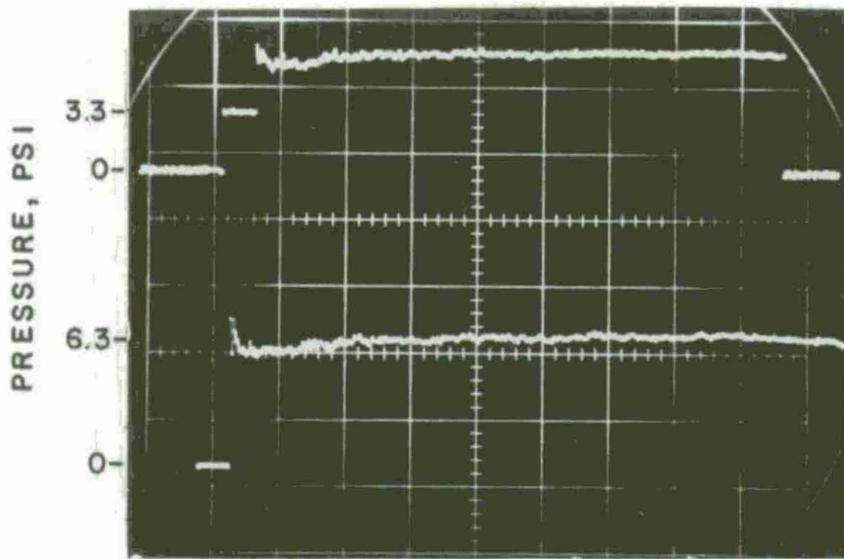


TIME, 5 MS/CM  
 UPPER - INPUT  
 LOWER - REFLECTED  
 (A) SHOT 24-75-172  
 POS. 1 & 2

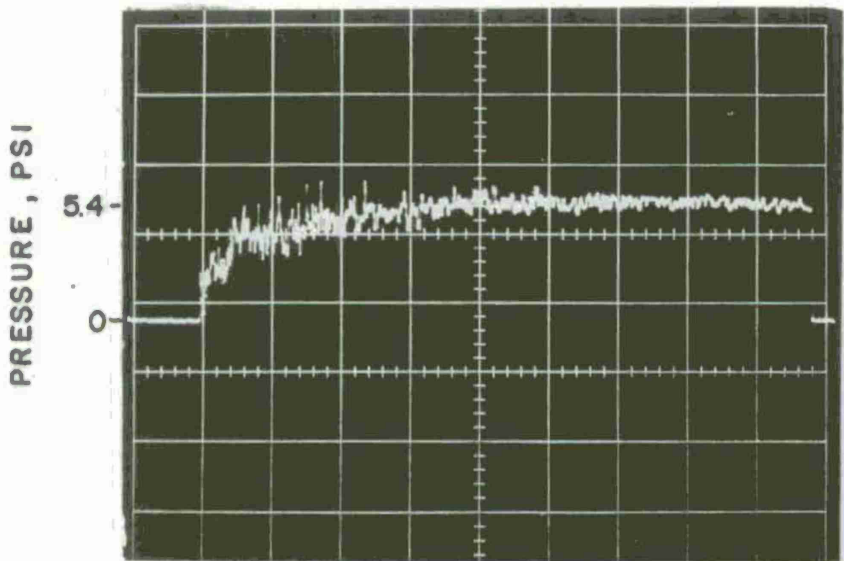


TIME, 5 MS/CM  
 UPPER - FILL FRONT  
 LOWER - FILL REAR  
 (B) SHOT 24-75-172  
 POS. 3 & 4

Figure 7. Pressure-Time Traces - Case II, 10.9 psi

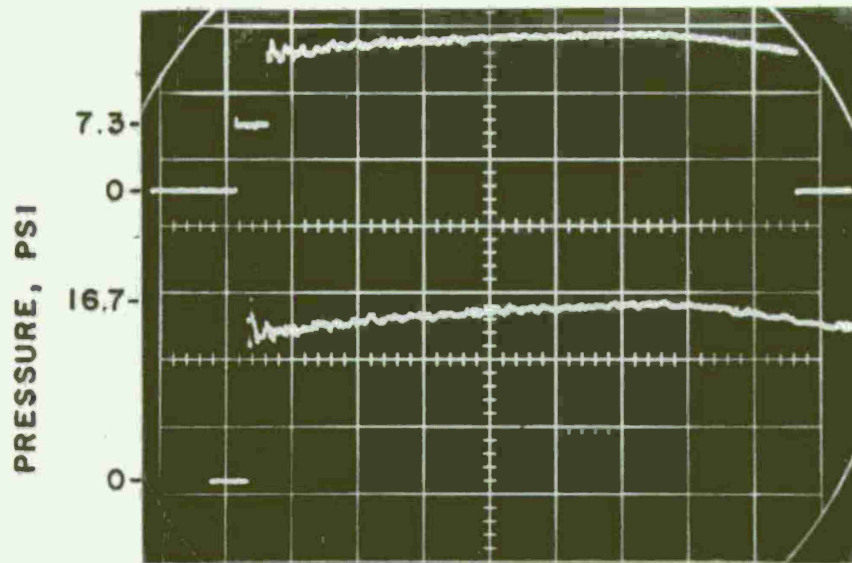


TIME, 5 MS/CM  
 UPPER - INPUT  
 LOWER - REFLECTED  
 (A) SHOT 24-75-179  
 POS. 1 & 2

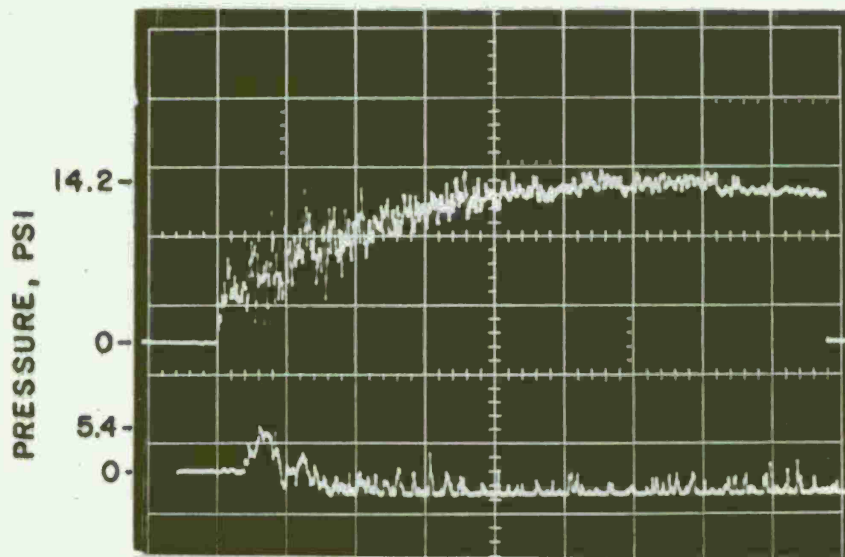


TIME, 5 MS/CM  
 UPPER - FILL FRONT  
 LOWER - TRACE LOST  
 (B) SHOT 24-74-179  
 POS. 3 & 4

Figure 8. Pressure-Time Traces - Case III, 3.3 psi

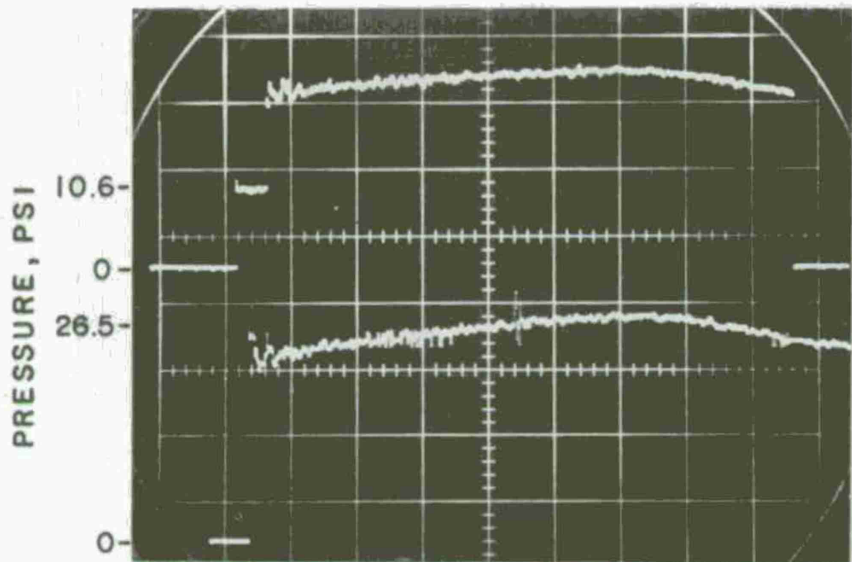


TIME, 5 MS/CM  
 UPPER - INPUT  
 LOWER - REFLECTED  
 (A) SHOT 24-75-180  
 POS. 1 & 2

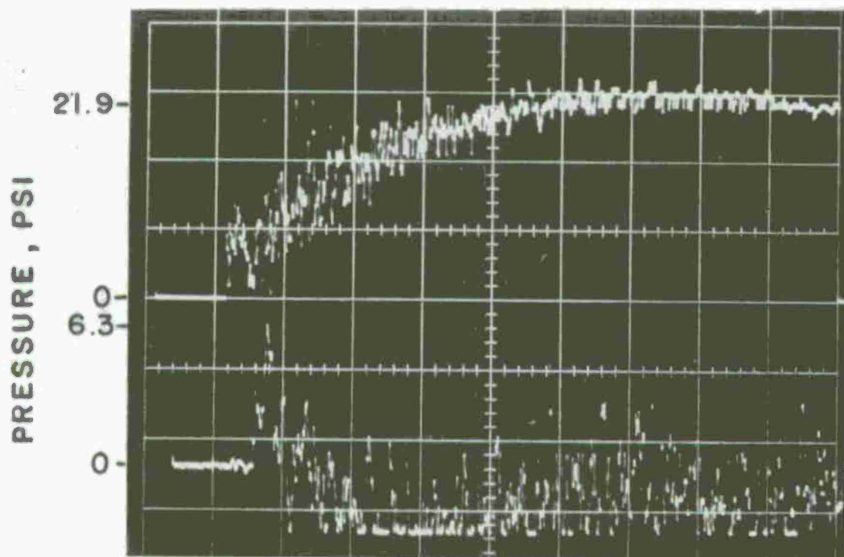


TIME, 5 MS/CM  
 UPPER - FILL, FRONT  
 LOWER - FILL REAR  
 (B) SHOT 24-75-180  
 POS. 3 & 4

Figure 9. Pressure-Time Traces - Case III, 7.3 psi



TIME, 5 MS/CM  
 UPPER- INPUT  
 LOWER- REFLECTED  
 (A) SHOT 24-75-181  
 POS. 1 & 2



TIME, 5 MS/CM  
 UPPER- FILL FRONT  
 LOWER- FILL REAR  
 (B) SHOT 24-75-181  
 POS. 3 & 4

Figure 10. Pressure-Time Traces - Case III, 10.6 psi

SHOT 24-75-147



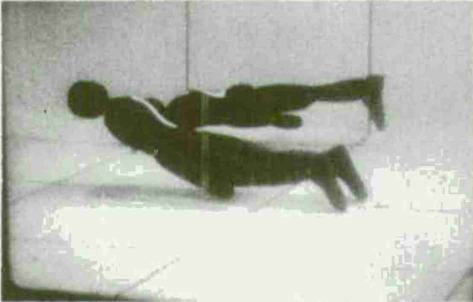
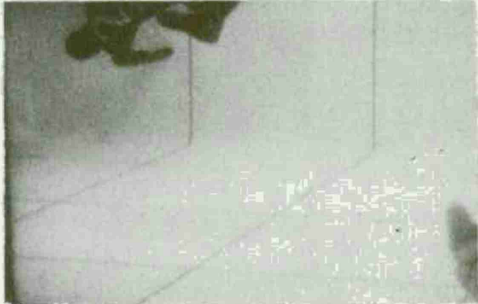



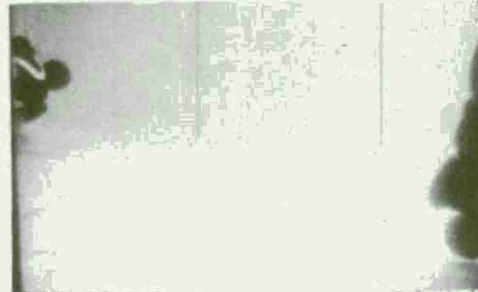
FRAME NUMBER	TIME, MSEC.	FRAME NUMBER	TIME, MSEC.
	0.2		112.0
	18.4		153.6
	39.2		216.0
	80.8		278.4

Figure 11. 49% Open Front-Prone on 6-inch Line, 7.5 psi

SHOT 24-75-150

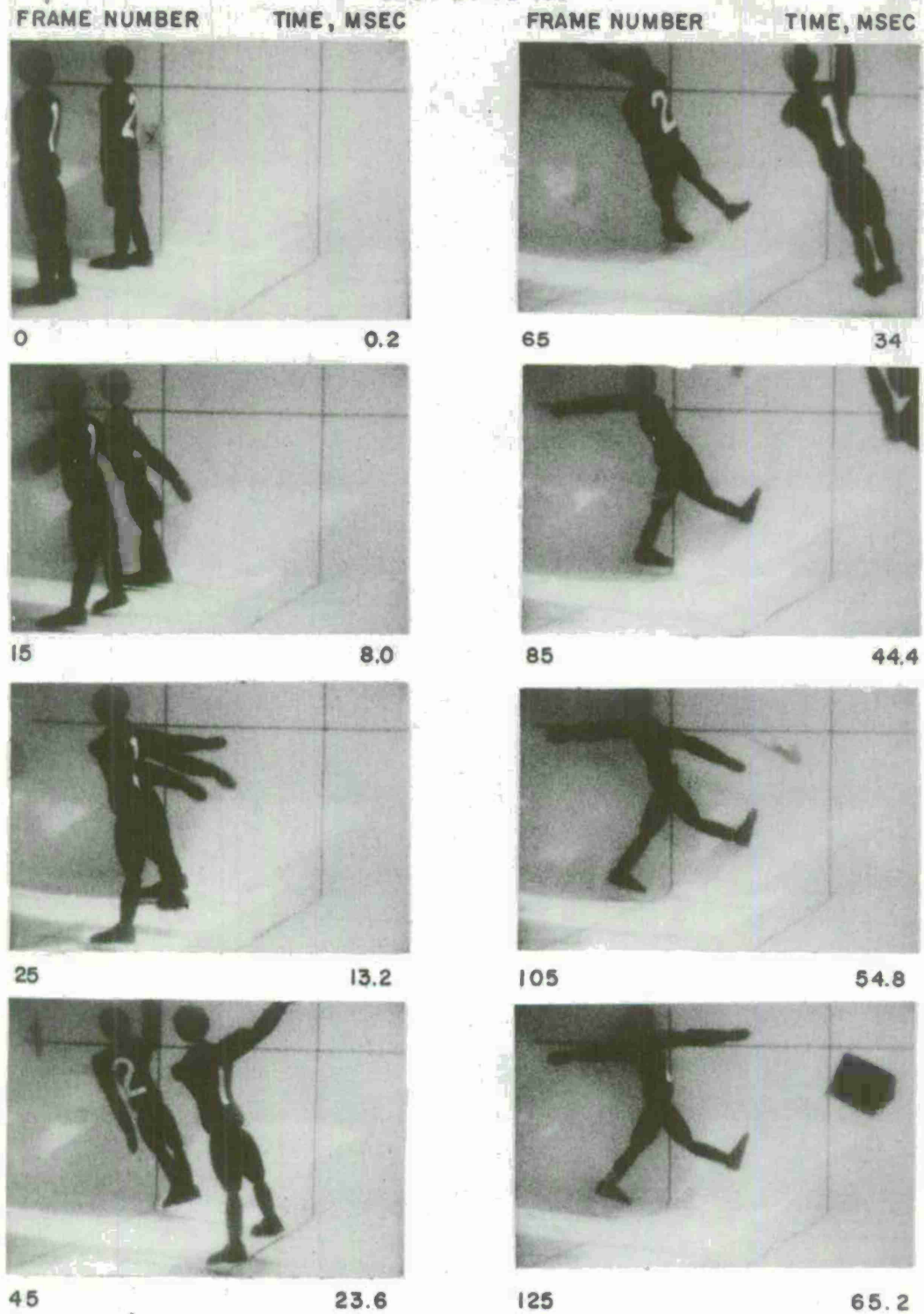


Figure 12. 49% Open Front-Standing on 6-inch Line, 7.4 psi

SHOT 24-75-150








SHOT NUMBER	TIME, MSEC	SHOT NUMBER	TIME, MSEC
	75.6		148.4
	86.0		179.6
	106.8		262.8
	127.6		

Figure 12. (Cont'd) 49% Open Front-Standing on 6-inch Line, 7.4 psi

floor grid intersections for the shots.

The frame time in milliseconds is calculated from the shock wave arrival inside of the front wall of the model. Distance moved across the floor grid lines divided by the frame time was calculated to give an average translational velocity along the model room. Arm rotation and whole body rotational velocity were calculated for several shots, as well.

Generally, the motion of the model dummies can be described as follows. In the prone position (Figure 11), No. 1 rotated up and backwards to rear of room. How fast and how far depends both on the pressure level and line location. No. 2 tended to move forward toward the front of the room with a rotation about the body length as well as a forward tumble.

In the standing position (Figure 12), No. 1 model dummy moved to rear of room in an almost upright position. Body bowed forward and the arms rotated backward. No. 2 rotated about the length of its body, moved somewhat to front of room, and fell into the right wall of the room. Again, pressure level and room location determined the magnitude of the velocities observed. The results are tabulated below.

#### C. Tables of Data

Tables I, II, and III list the results according to shot number, input pressure level, position, and location of the model dummies.

Table I lists the results for Case I - 49% open front, Table II for Case II - 20% open front, and Table III for Case III - 20% open front with 47% open back. The tables show values of translation from "little motion," < 1 ft/sec to about 50 ft/sec. Rotational velocities of the arms vary between a few rad/sec to about 200 rad/sec. Table IV summarizes the three separate model configurations for quick comparison.

#### IV. COMPUTER CODE PREDICTIONS

This section shows the results of room filling predictions made by a BRL computer program taken from Reference 2. The predicted flows are then utilized to calculate the motion parameters. The coefficients of drag used for the translation calculations are taken from Reference 3 for full size persons, and are assumed valid for the model dummies used as well.

---

<sup>2</sup>George A. Coulter, "Blast Loading in Existing Structures - Basement Models," *Ballistic Research Laboratories Memorandum Report No. 2208*, August 1972, AD 751769.

<sup>3</sup>S. F. Hoerner, "Fluid-Dynamic Drag," 148 Busted Drive, Midland Park, New Jersey 07432, published by author, 1965.

Table I. Data from Case I - 49% Open Front

Shot Number	Input Pressure psi	Ambient Pressure psi	Ambient Temperature °C	Grid Line Position	Motion
24-75-129	3.8	14.9	20.2	Prone-6"	①moved forward at 3 ft/sec
24-75-158	3.6	15.0	21.5	Prone-12"	Little motion
24-75-142	3.8	14.8	31.5	Prone-18"	Little motion
24-75-147	7.5	14.8	29.0	Prone-6"	①rotated up and back at 12-18 rad/sec ②moved to right wall at 9 ft/sec
25-75-146	7.5	14.8	28.9	Prone-12"	①moved forward at 4 ft/sec
24-75-143	7.5	14.8	31.6	Prone-18"	Little motion
24-75-148	10.4	14.8	22.7	Prone-6"	①moved to rear at 4 ft/sec. Rotated up and back at 16-19 rad/sec ②moved forward at 5 ft/sec. Arms forward at 14 rad/sec
24-75-145	11.1	14.8	29.0	Prone-12"	①moved to rear at 5 ft/sec. Body rotated up and back at 17-22 rad/sec ②moved forward at 7 ft/sec. Body rotated toward left at 22 rad/sec
24-75-159	10.9	15.0	21.6	Prone-12"	①moved forward at 6 ft/sec
24-75-144	11.3	14.8	25.7	Prone-18"	Little motion
24-75-149	3.6	14.8	24.6	Standing-6"	①moved back, standing, at 6 ft/sec ②rotated left at 20 rad/sec

Table I. (Cont'd) Data from Case I - 49% Open Front

Shot Number	Input Pressure psi	Ambient Pressure psi	Ambient Temperature °C	Grid Line Position	Motion
24-75-151	3.5	14.8	22.4	Standing-12"	①moved back standing at 3 ft/sec. Rotated to left at 8 rad/sec ②rotated to left at 8 rad/sec
24-75-156	3.6	14.9	20.0	Standing-18"	①fell over ②remained standing
24-75-150	7.5	14.8	20.8	Standing-6"	①moved back at 21ft/sec. Arms rotated backwards at 60-250 rad/sec ②had arms rotated backwards at 75-210 rad/sec. Body rotated left at 85 rad/sec
24-75-153	7.7	14.8	24.7	Standing-12"	①moved back at 15 ft/sec. Arms rotated back at 34-84 rad/sec. ②had body rotation to left of 36 rad/sec
24-75-157	7.7	14.9	23.0	Standing-18"	①moved back at 8 ft/sec. Arms rotated at 14-60 rad/sec ②had a body rotation of 25 rad/sec
24-75-154	11.6	14.8	27.4	Standing-12"	①moved to rear at 25 ft/sec. Arms rotated backwards at 125-187 rad/sec
24-75-155	11.1	14.8	25.6	Standing-18"	①moved to rear at 13 ft/sec. Arms rotated at 52-151 rad/sec ②rotated to left at 46 rad/sec.

NOTES: (1) Model dummy ① was placed face down or standing on centerline of floor for all shots.

(2) Model dummy ② was placed on floor face down or standing 4 inches from right wall for all shots.

Table II. Data from Case II - 20% Open Front

Shot Number	Input Pressure psi	Ambient Pressure psi	Ambient Temperature °C	Grid Line Position	Motion
24-75-167	3.5	14.9	17.4	Prone-6"	①moved to rear at 2-3 ft/sec. ②rotated left at 8 rad/sec.
24-75-162	3.6	14.9	20.6	Prone-12"	Little motion
24-75-174	3.7	15.0	21.6	Prone-18"	Little motion
24-75-169	11.4	14.9	16.8	Prone-6"	①moved to rear at 12 ft/sec. ②rotated about body, face to left, at 17 rad/sec.
24-75-165	11.1	14.9	16.0	Prone-12"	①moved to rear at 9 ft/sec. ②rotated upward at 19 rad/sec to hit ceiling.
24-75-172	10.9	15.0	22.5	Prone-18"	①moved to rear at 12 ft/sec. Rotated up at 37 rad/sec. ②moved slowly forward and to right.
24-75-168	3.4	14.8	17.5	Standing-6"	①moved to rear at 15 ft/sec. Arm rotated at 60-90 rad/sec. ②moved arm forward at 19-23 rad/sec.
24-75-163	3.6	14.9	16.0	Standing-12"	①moved to rear at 12 ft/sec. Arm moved backward at 43-49 rad/sec/ ②had a body rotation to left of 14 rad/sec.
24-75-173	3.7	15.0	21.6	Standing-18"	①moved to rear at 11 ft/sec. ②moved slowly forward and fell down.

Table II. (Cont'd) Data From Case II - 20% Open Front

Shot Number	Input Pressure psi	Ambient Pressure psi	Ambient Temperature °C	Grid Line Position	Motion
24-75-170	10.6	14.9	13.5	Standing-6"	①moved to rear at 47 ft/sec. Arm rotated back at 100-500 rad/sec. ②had arm rotated forward at 109-154 rad/sec. The body rotated to left and moved forward at 35-88 rad/sec.
24-75-164	11.1	14.9	16.0	Standing-12"	①moved to rear at 40 ft/sec. Arm rotated to rear at 127-314 rad/sec. ②had a body rotation to left of 34-48 rad/sec.
24-75-171	10.6	14.9	15.2	Standing-18"	①had body rotation to left of 30-43 rad/sec. Arm rotated to rear at 50-127 rad/sec. Dummies interchanged for this shot.

Table III. Data from Case III - 20% Open Front with 47% Open Back

Shot Number	Input Pressure psi	Ambient Pressure psi	Ambient Temperature °C	Grid Line Position	Motion
24-75-179	3.3	14.9	13.0	Prone-12"	①moved backward at 3 ft/sec. Rotated face to left at 25-50 rad/sec. ②moved forward at 2 ft/sec.
24-75-180	7.3	14.9	13.5	Prone-12"	①moved to rear at 11 ft/sec. Rotated upward at 23-49 rad/sec. ②moved slowly to front.
24-75-181	10.6	14.9	15.7	Prone-12"	①moved to rear at 37 ft/sec. ②not used. ③rotated arm back at 151-218 rad/sec.
24-75-182	3.5	14.9	19.4	Standing-12"	②moved to rear at 16 ft/sec. Arm rotated to rear at 42 rad/sec. Dummy ② replaced ①.
24-75-183	7.6	14.9	19.5	Standing-12"	①moved backwards at 28 ft/sec. Arm rotated to rear at 84-192 rad/sec.
24-75-184	10.8	14.9	19.2	Standing-12"	①moved to rear at 37 ft/sec. Arm rotated to rear 151-218 rad/sec.

Table IV. Comparison of Data from Cases I, II, and III

Case	Average Input Pressure psi	Position	Grid Line Position in.	Motion
I 49% open front	3.6	Prone	6	3 ft/sec
			12	< 1 ft/sec
			18	< 1 ft/sec
	7.5	Prone	6	9 ft/sec, 12-18 rad/sec
			12	4 ft/sec
			18	< 1 ft/sec
	10.9	Prone	6	5 ft/sec, 16-19 rad/sec
			12	7 ft/sec, 17-22 rad/sec
			18	< 1 ft/sec
	3.6	Standing	6	6 ft/sec, 20 rad/sec
			12	3 ft/sec, 8 rad/sec
			18	< 1 ft/sec
	7.5	Standing	6	21 ft/sec, 60-250 rad/sec
			12	15 ft/sec, 34-84 rad/sec
			18	8 ft/sec, 41-60 rad/sec
10.9	Standing	12	25 ft/sec, 125-187 rad/sec	
		18	13 ft/sec, 52-151 rad/sec	
II 20% open front	3.6	Prone	6	3 ft/sec, 8 rad/sec
			12	< 1 ft/sec
			18	< 1 ft/sec
	10.9	Prone	6	12 ft/sec, 17 rad/sec
			12	9 ft/sec, 19 rad/sec
			18	12 ft/sec, 37 rad/sec
	3.6	Standing	6	15 ft/sec, 60-90 rad/sec
			12	12 ft/sec, 43-49 rad/sec
			18	11 ft/sec
	10.9	Standing	6	47 ft/sec, 100-500 rad/sec
			12	40 ft/sec, 127-314 rad/sec
			18	33 ft/sec, 111-314 rad/sec
III 20% open front and 47% open back	3.6	Prone	12	3 ft/sec, 25-50 rad/sec
	7.5	Prone	12	11 ft/sec, 23-49 rad/sec
	10.9	Prone	12	37 ft/sec, 151-218 rad/sec
	3.6	Standing	12	16 ft/sec, 42 rad/sec
	7.5	Standing	12	28 ft/sec, 84-192 rad/sec
	10.9	Standing	12	37 ft/sec, 151-218 rad/sec

## A. Fill-Time Predictions

Fill-time predictions were made by means of a computer code as noted above. Predictions were made in two ways. First, the shelter model was treated as if it consisted of the front room only. Then, it was treated as one large room equal to the volume of the two rooms. The fill predictions were then made for the cases of 49% open front for a small room and a large room, and 20% open front for a small room and large room. All cases for the model shelter were predicted for 3.6, 7.5, and 10.9 psi input pressure measured before reflection at the front of the model.

Table V shows a sample set of predictions. The first heading gives the input parameters of entrance area ( $\text{ft}^2$ ), the room volume ( $\text{ft}^3$ ), a time increment of calculation (sec), ambient pressure (psi), and density of the initial input shock wave level after reflection ( $\text{slugs}/\text{ft}^3$ ).

The second heading gives the predicted fill parameters: time (sec), average room pressure (psi), average room density ( $\text{slugs}/\text{ft}^3$ ), flow velocity at entrance ( $\text{ft}/\text{sec}$ ), and the entrance dynamic pressure,  $Q$  (psi).

The complete predictions are presented in Appendix B. Plots of pressure-time for the rooms filling are shown in Figures 13 - 18. On each plot the dotted line represents the reflected shock wave as a step input; the solid line represents the predicted fill curve, and the x-symbols are the data points taken from the oscilloscope records. Most of the scatter is caused by the reflections of the internal diffracted shock waves as the room fills. The computer code predicts the average room pressure and does not allow for diffracted waves. A more elaborate three-dimensional hydrocode might be used if greater accuracy is required.

Fill parameters for full size room shelters are also tabulated in Appendix B and will be discussed later.

## B. Translation Parameters

A simple stepwise calculation with a computer code (Ref. 1) was used to predict translation parameters for the model dummy when placed on the flow centerline of the front room.

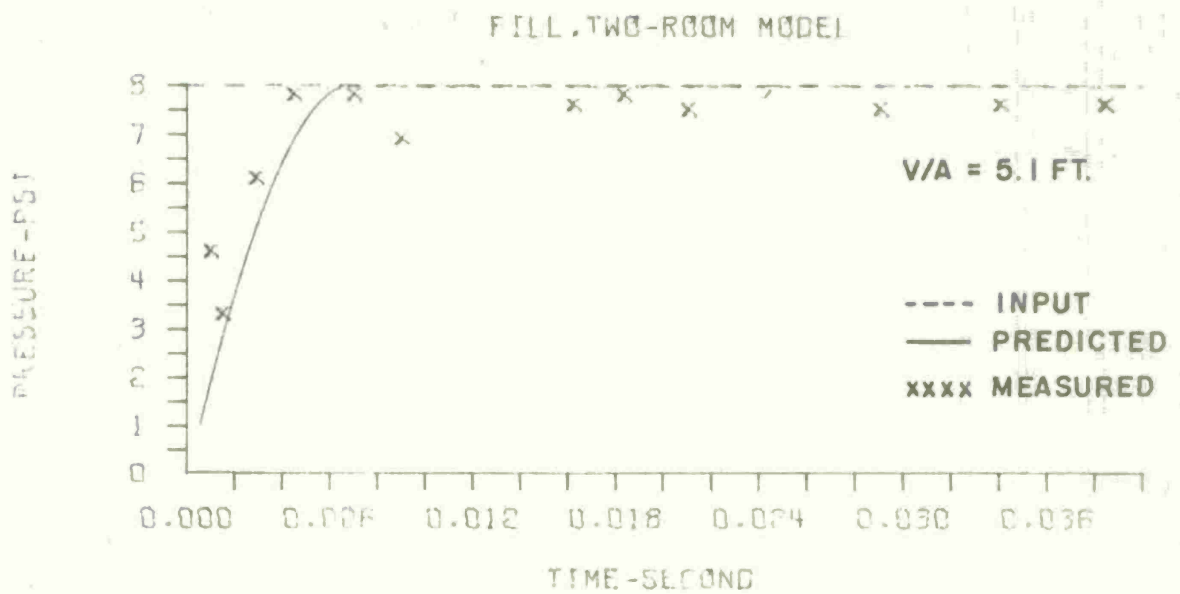
The method used was to calculate the drag from the predicted room filling parameters - entrance flow velocity and density. Coefficients of drag times area ( $C_D A$ ,  $\text{ft}^2$ ) for a 168-lb man in the prone and standing positions were taken from Reference 3. They were also assumed to apply to a model dummy when scaled to its area. The dummy's translational acceleration, velocity, and distance were then calculated as a function of time by using the predicted dynamic pressure as a load for the  $C_D A$  of the dummy. Tables VII and VIII show some sample parameters. The remainder are given in Appendix D.

Table V. Fill-Time Prediction - 49% Open, 7.5 psi - Front Room

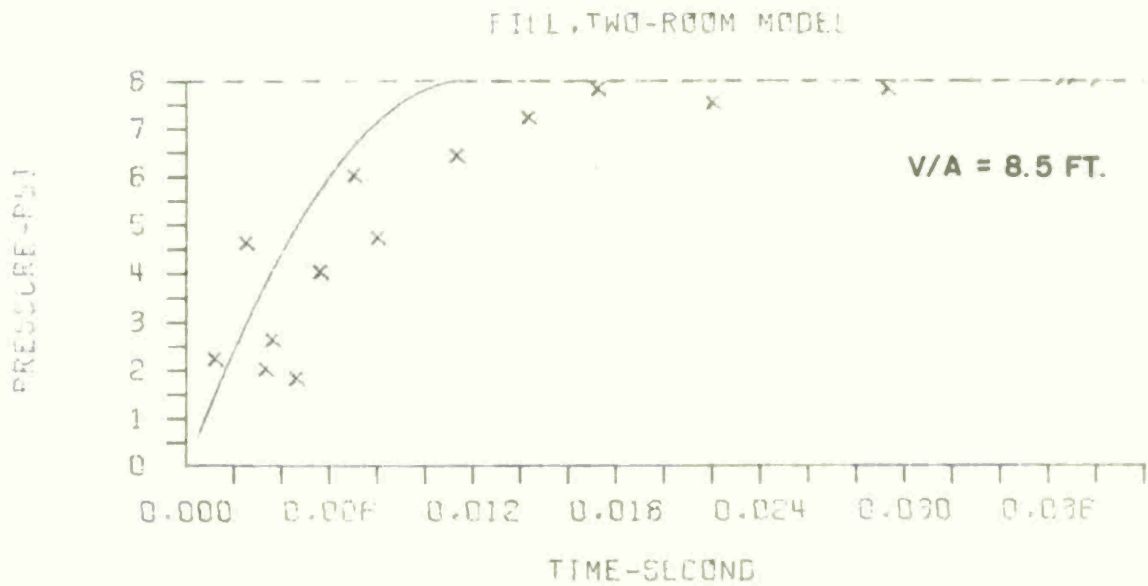
AREA1	VOLUME	TIME	PRESSURE	DENSITY
0.677E 00	0.347209E 01	0.500000E-03	0.148000E 02	0.407000E-02
TIME	PRESSURE	DENS	U2	DPT
SECONDS	PSI	WE-S2/F4	FPS	PSI
0.500E-03	0.153015E 01	0.250851E-02	0.877436E 03	0.620322E 01
0.100E-02	0.317435E 01	0.271689E-02	0.858604E 03	0.637225E 01
0.150E-02	0.485642E 01	0.292754E-02	0.810434E 03	0.607997E 01
0.200E-02	0.647780E 01	0.313059E-02	0.732836E 03	0.529944E 01
0.250E-02	0.802269E 01	0.332405E-02	0.659832E 03	0.454644E 01
0.300E-02	0.947821E 01	0.350633E-02	0.591304E 03	0.383857E 01
0.350E-02	0.108341E 02	0.367613E-02	0.527043E 03	0.318726E 01
0.400E-02	0.120825E 02	0.383247E-02	0.466770E 03	0.259890E 01
0.450E-02	0.132174E 02	0.397459E-02	0.410153E 03	0.207600E 01
0.500E-02	0.142342E 02	0.410193E-02	0.356818E 03	0.161828E 01
0.550E-02	0.151298E 02	0.421409E-02	0.306352E 03	0.122366E 01
0.600E-02	0.159015E 02	0.431072E-02	0.258301E 03	0.888991E 00
0.650E-02	0.165469E 02	0.439155E-02	0.212152E 03	0.610713E 00
0.700E-02	0.170634E 02	0.445623E-02	0.167276E 03	0.385357E 00
0.750E-02	0.174469E 02	0.450426E-02	0.122757E 03	0.209970E 00
0.800E-02	0.176886E 02	0.453452E-02	0.766873E 02	0.826465E-01
0.850E-02	0.177399E 02	0.454095E-02	0.161927E 02	0.370453E-02
0.900E-02	0.176490E 02	0.452826E-02	0.286740E 02	0.129524E-01
0.950E-02	0.177574E 02	0.454184E-02	0.342625E 02	0.165712E-01
0.100E-01	0.176483E 02	0.452662E-02	0.344220E 02	0.186622E-01
0.105E-01	0.177575E 02	0.454029E-02	0.344914E 02	0.167931E-01
0.110E-01	0.176483E 02	0.452506E-02	0.344401E 02	0.186755E-01
0.115E-01	0.177575E 02	0.453874E-02	0.344970E 02	0.167985E-01
0.120E-01	0.176483E 02	0.452351E-02	0.344463E 02	0.186758E-01
0.125E-01	0.177575E 02	0.453719E-02	0.345032E 02	0.168046E-01
0.130E-01	0.176483E 02	0.452197E-02	0.344525E 02	0.186761E-01
0.135E-01	0.177575E 02	0.453565E-02	0.345094E 02	0.168106E-01
0.140E-01	0.176482E 02	0.452043E-02	0.344586E 02	0.186765E-01
0.145E-01	0.177575E 02	0.453411E-02	0.345156E 02	0.168166E-01
0.150E-01	0.176482E 02	0.451889E-02	0.344648E 02	0.186768E-01
0.155E-01	0.177575E 02	0.453257E-02	0.345218E 02	0.168227E-01
0.160E-01	0.176482E 02	0.451736E-02	0.344709E 02	0.186771E-01
0.165E-01	0.177575E 02	0.453105E-02	0.345280E 02	0.168287E-01
0.170E-01	0.176482E 02	0.451584E-02	0.344770E 02	0.186775E-01
0.175E-01	0.177575E 02	0.452952E-02	0.345341E 02	0.168346E-01
0.180E-01	0.176482E 02	0.451431E-02	0.344832E 02	0.186778E-01
0.185E-01	0.177575E 02	0.452800E-02	0.345402E 02	0.168406E-01
0.190E-01	0.176481E 02	0.451280E-02	0.344892E 02	0.186781E-01
0.195E-01	0.177575E 02	0.452649E-02	0.345463E 02	0.168465E-01
0.200E-01	0.176481E 02	0.451129E-02	0.344953E 02	0.186785E-01
0.205E-01	0.177575E 02	0.452498E-02	0.345524E 02	0.168525E-01

Table VI. Fill-Time Prediction - 49% Open, 7.5 psi - Rear Room

AREA1	VOLUME	TIME	PRESSURE	DENSITY
TIME SECONDS	PRESSURE PSI	DENS UE-S2/F4	U2 FPS	DPT PSI
0.677E-00	0.578700E-01	0.500000E-03	0.148000E-02	0.407000E-02
0.500E-03	0.918034E-00	0.242910E-02	0.877436E-03	0.620322E-01
0.100E-02	0.187763E-01	0.255182E-02	0.866137E-03	0.630999E-01
0.150E-02	0.287905E-01	0.267811E-02	0.854328E-03	0.640453E-01
0.200E-02	0.389343E-01	0.280514E-02	0.824303E-03	0.621586E-01
0.250E-02	0.488845E-01	0.292975E-02	0.776486E-03	0.574726E-01
0.300E-02	0.586043E-01	0.305147E-02	0.731378E-03	0.528453E-01
0.350E-02	0.680602E-01	0.316989E-02	0.687463E-03	0.483247E-01
0.400E-02	0.772233E-01	0.328464E-02	0.645210E-03	0.439497E-01
0.450E-02	0.860679E-01	0.339540E-02	0.604579E-03	0.397507E-01
0.500E-02	0.945718E-01	0.350190E-02	0.565520E-03	0.357505E-01
0.550E-02	0.102715E-02	0.360389E-02	0.527973E-03	0.319654E-01
0.600E-02	0.110485E-02	0.370117E-02	0.491873E-03	0.284058E-01
0.650E-02	0.117864E-02	0.379358E-02	0.457151E-03	0.250776E-01
0.700E-02	0.124843E-02	0.388098E-02	0.423731E-03	0.219826E-01
0.750E-02	0.131412E-02	0.396324E-02	0.391534E-03	0.191195E-01
0.800E-02	0.137563E-02	0.404028E-02	0.360480E-03	0.164846E-01
0.850E-02	0.143291E-02	0.411201E-02	0.330482E-03	0.140724E-01
0.900E-02	0.148591E-02	0.417838E-02	0.301455E-03	0.118762E-01
0.950E-02	0.153458E-02	0.423933E-02	0.273309E-03	0.988856E-02
0.100E-01	0.157889E-02	0.429822E-02	0.245949E-03	0.810152E-02
0.105E-01	0.161881E-02	0.434481E-02	0.219279E-03	0.650722E-02
0.110E-01	0.165431E-02	0.438927E-02	0.193192E-03	0.509802E-02
0.115E-01	0.168535E-02	0.442814E-02	0.167571E-03	0.386682E-02
0.120E-01	0.171189E-02	0.446138E-02	0.142277E-03	0.280726E-02
0.125E-01	0.173387E-02	0.448891E-02	0.117131E-03	0.191404E-02
0.130E-01	0.175120E-02	0.451060E-02	0.918699E-04	0.118326E-02
0.135E-01	0.176369E-02	0.452625E-02	0.659996E-04	0.613033E-03
0.140E-01	0.177093E-02	0.453531E-02	0.381107E-04	0.204971E-03
0.145E-01	0.176839E-02	0.453164E-02	0.138285E-04	0.301077E-04
0.150E-01	0.177206E-02	0.453635E-02	0.197714E-04	0.552224E-04
0.155E-01	0.176814E-02	0.453089E-02	0.205887E-04	0.667384E-04
0.160E-01	0.177207E-02	0.453581E-02	0.206670E-04	0.603365E-04
0.165E-01	0.176814E-02	0.453033E-02	0.206529E-04	0.671468E-04
0.170E-01	0.177207E-02	0.453525E-02	0.206650E-04	0.603245E-04
0.175E-01	0.176814E-02	0.452977E-02	0.206540E-04	0.671462E-04
0.180E-01	0.177207E-02	0.453469E-02	0.206663E-04	0.603324E-04
0.185E-01	0.176814E-02	0.452921E-02	0.206554E-04	0.671466E-04
0.190E-01	0.177207E-02	0.453413E-02	0.206677E-04	0.603402E-04
0.195E-01	0.176814E-02	0.452865E-02	0.206567E-04	0.671470E-04
0.200E-01	0.177207E-02	0.453357E-02	0.206690E-04	0.603480E-04
0.205E-01	0.176814E-02	0.452810E-02	0.206581E-04	0.671475E-04
0.210E-01	0.177207E-02	0.453302E-02	0.206703E-04	0.603559E-04
0.215E-01	0.176814E-02	0.452754E-02	0.206594E-04	0.671479E-04
0.220E-01	0.177207E-02	0.453246E-02	0.206717E-04	0.603637E-04
0.225E-01	0.176814E-02	0.452698E-02	0.206607E-04	0.671484E-04
0.230E-01	0.177207E-02	0.453190E-02	0.206730E-04	0.603715E-04
0.235E-01	0.176814E-02	0.452643E-02	0.206621E-04	0.671488E-04
0.240E-01	0.177207E-02	0.453135E-02	0.206743E-04	0.603793E-04
0.245E-01	0.176814E-02	0.452588E-02	0.206634E-04	0.671492E-04

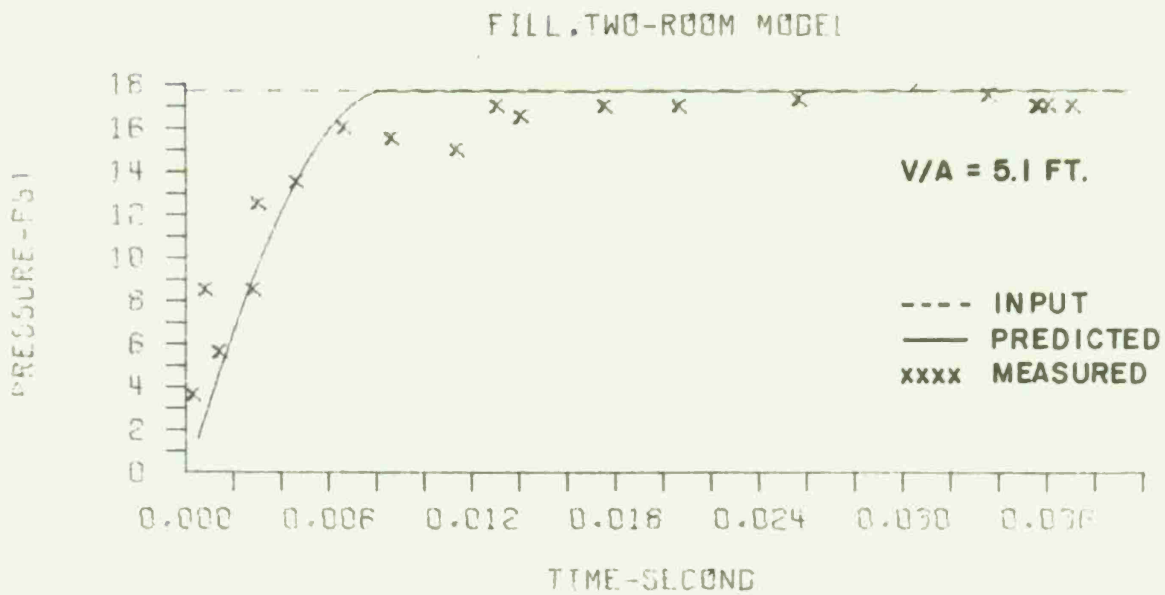


**(A) SHOT 24-75-158  
FRONT ROOM**

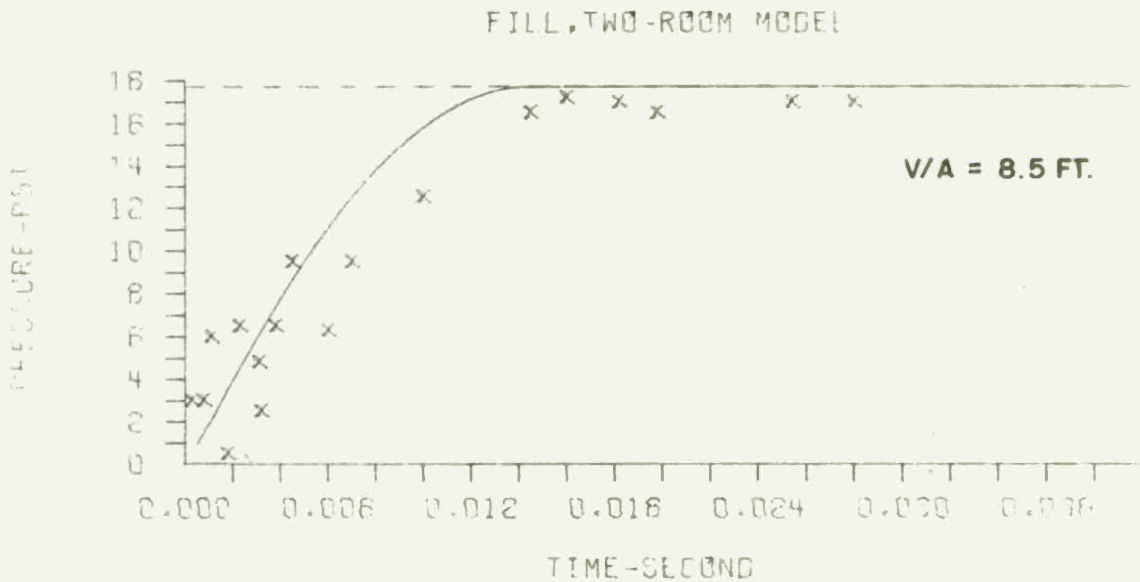


**(B) SHOT 24-75-158  
REAR ROOM**

Figure 13. Pressure-Fill Predictions - 49% Opening, 3.6 psi

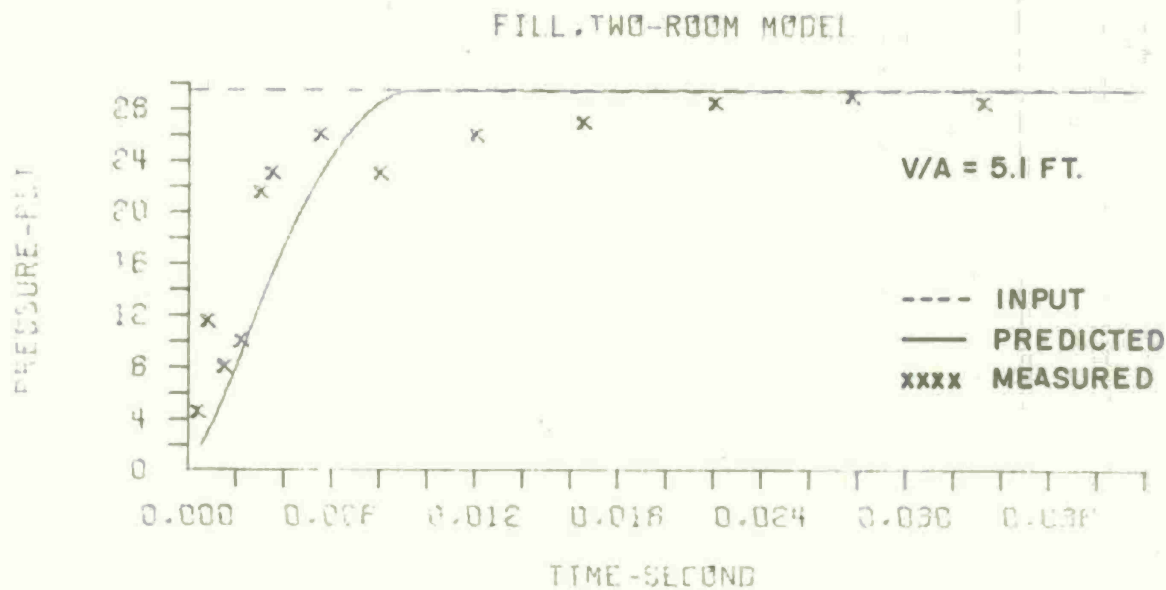


**(A) SHOT 24-75-150  
FRONT ROOM**

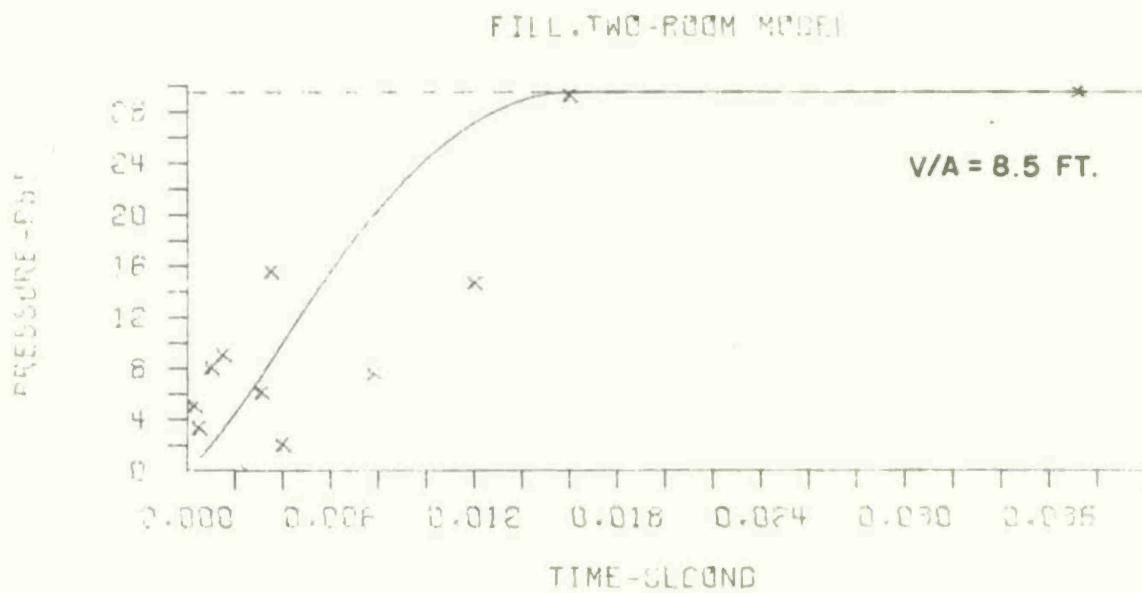


**(B) SHOT 24-75-150  
REAR ROOM**

Figure 14. Pressure-Fill Predictions - 49% Opening, 7.5 psi

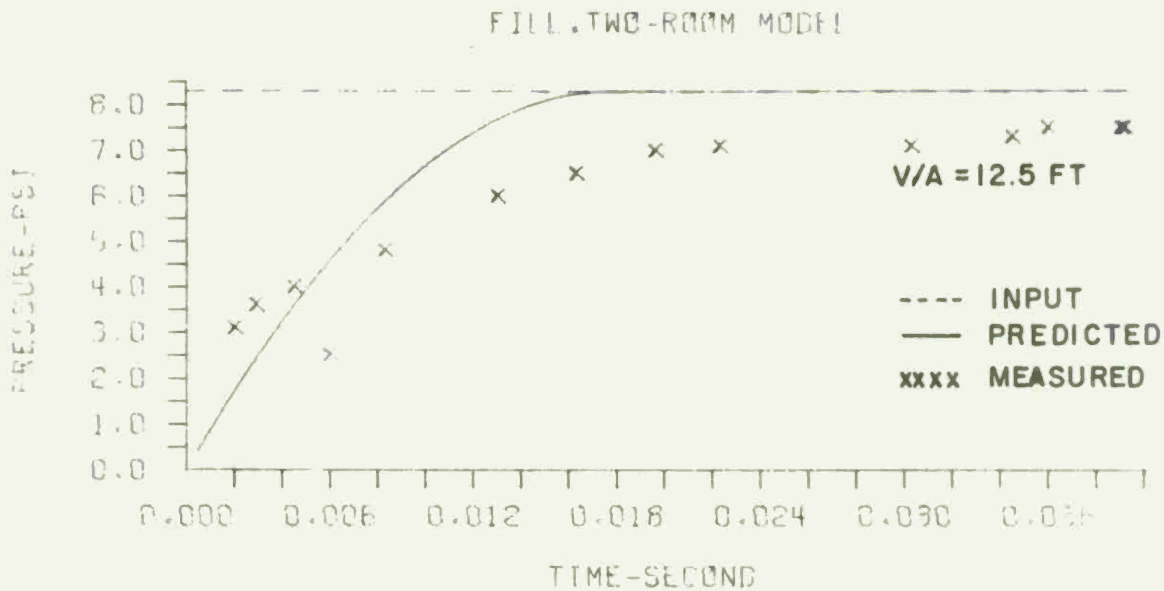


**(A) SHOT 24-75-159  
FRONT ROOM**

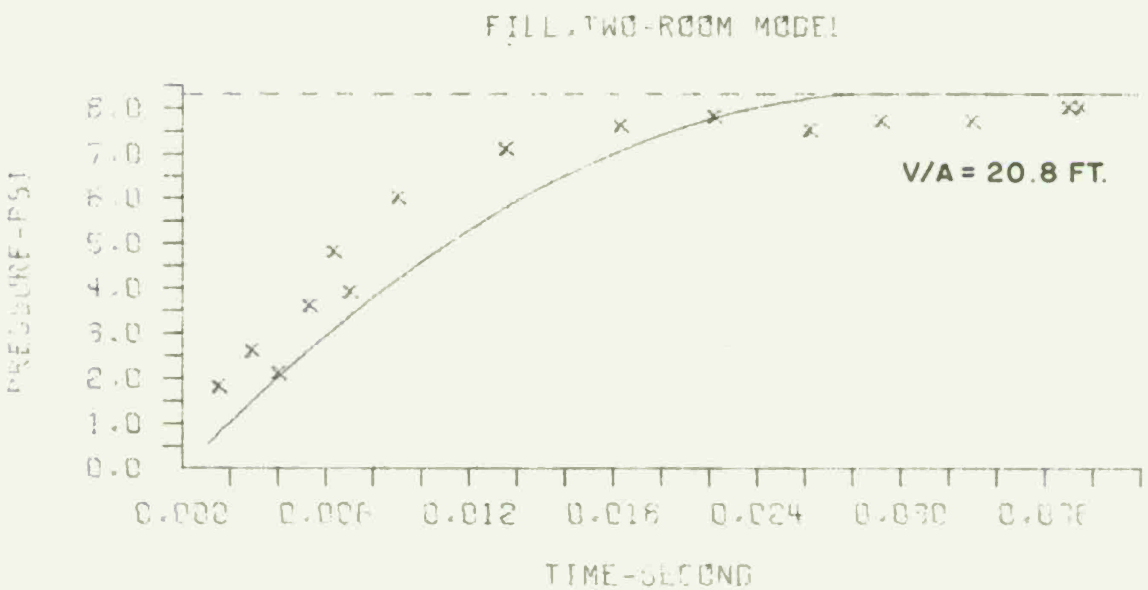


**(B) SHOT 24-75-159  
REAR ROOM**

Figure 15. Pressure-Fill Predictions - 49% Opening, 10.9 psi



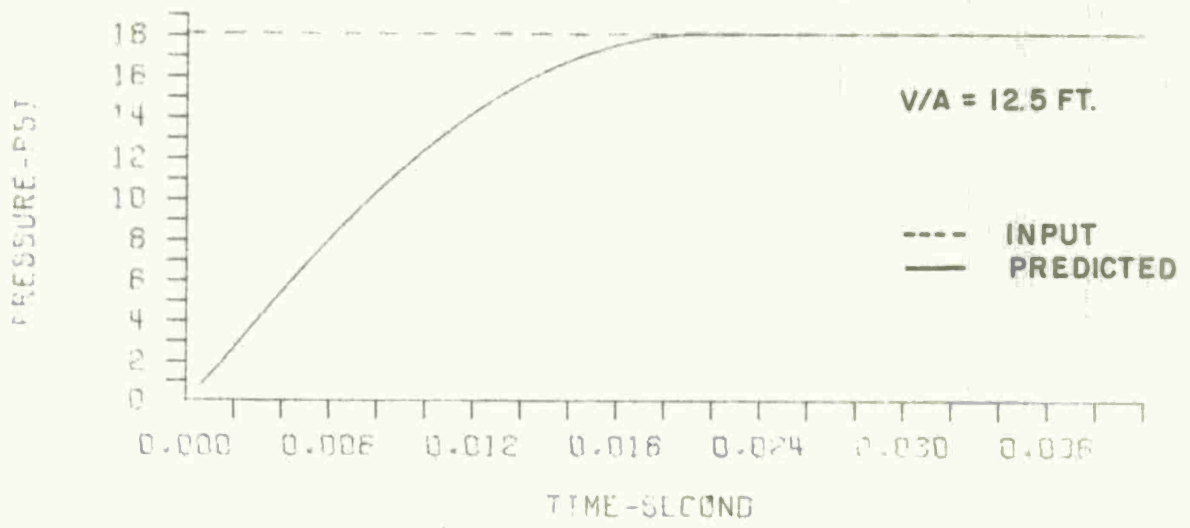
**(A) SHOT 24-75-162  
FRONT ROOM**



**(B) SHOT 24-75-162  
REAR ROOM**

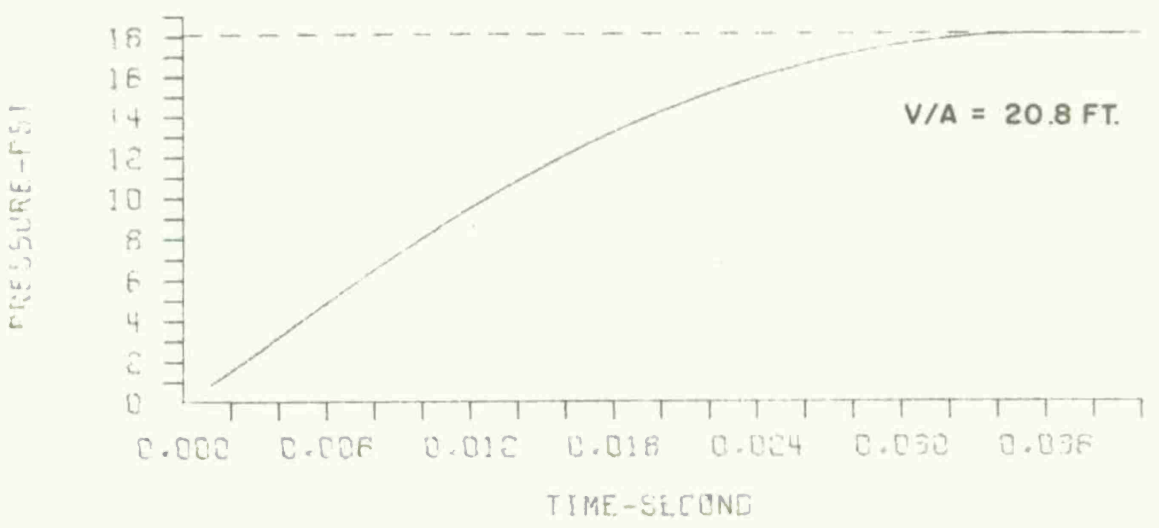
Figure 16. Pressure-Fill Predictions - 20% Opening, 3.5 psi

FILL-TWO-ROOM MODEL



(A) PREDICTED FRONT ROOM

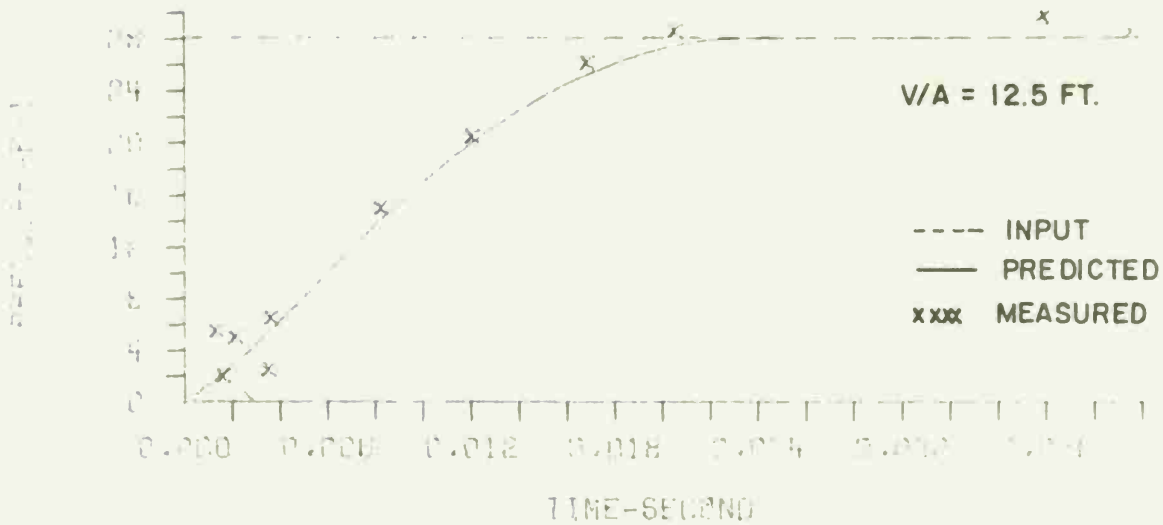
FILL-TWO-ROOM MODEL



(B) PREDICTED REAR ROOM

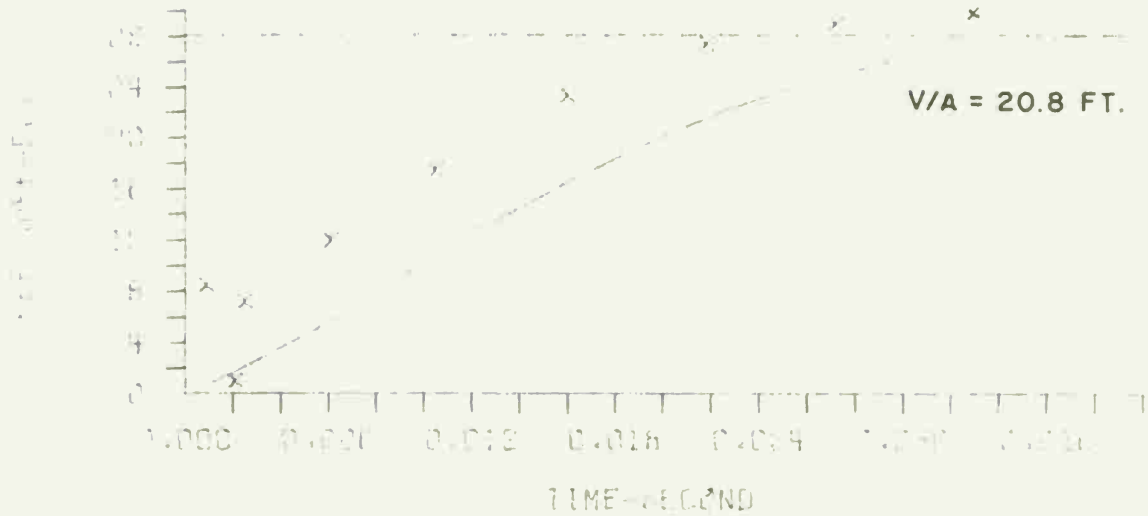
Figure 17. Pressure-Fill Predictions - 20% Opening, 7.5 psi

FILL-TWO-ROOM MODEL



(A) SHOT 24-75-172  
FRONT ROOM

FILL-TWO-ROOM MODEL



(B) SHOT 24-75-172  
REAR ROOM

Figure 18. Pressure-Fill Predictions - 20% Opening, 10.9 psi

Table VII. Predicted Translation Parameters - Prone Position  
at Entrance - 49% Open, 7.5 psi

TWO-ROOM MODEL - V/A = 5.1 FT

SHOT 24-75-150, 7.5 PSI

TIME-SEC	DISTANCE-FT	VELOCITY-FT/SEC	ACCEL.-FT/SEC/SEC
0.0005	0.0002	0.6625	1325.0051
0.0010	0.0007	1.3420	1358.9100
0.0015	0.0015	1.9891	1294.2264
0.0020	0.0026	2.5518	1125.4648
0.0025	0.0040	3.0334	963.1823
0.0030	0.0056	3.4390	811.1976
0.0035	0.0075	3.7747	671.4227
0.0040	0.0094	4.0476	545.7249
0.0045	0.0115	4.2647	434.2465
0.0050	0.0137	4.4332	336.9275
0.0055	0.0159	4.5599	253.5054
0.0060	0.0182	4.6513	182.8577
0.0065	0.0206	4.7136	124.5201
0.0070	0.0229	4.7523	77.3953
0.0075	0.0253	4.7729	41.2552

TWO-ROOM MODEL - V/A = 6.54 FT

SHOT 24-75-150, 7.5 PSI

TIME-SEC	DISTANCE-FT	VELOCITY-FT/SEC	ACCEL.-FT/SEC/SEC
0.0005	0.0002	0.6625	1325.0051
0.0010	0.0007	1.3354	1345.7464
0.0015	0.0015	2.0171	1363.5397
0.0020	0.0027	2.6777	1321.0794
0.0025	0.0042	3.2871	1218.8688
0.0030	0.0060	3.8462	1118.2196
0.0035	0.0080	4.3563	1020.2012
0.0040	0.0103	4.8192	925.6826
0.0045	0.0128	5.2367	835.0434
0.0050	0.0155	5.6112	748.9706
0.0055	0.0184	5.9451	667.8322
0.0060	0.0215	6.2409	591.6107
0.0065	0.0246	6.5011	520.4769
0.0070	0.0280	6.7284	454.5165
0.0075	0.0314	6.9252	393.6016
0.0080	0.0349	7.0942	337.9433
0.0085	0.0385	7.2377	287.1181
0.0090	0.0421	7.3583	241.0882
0.0095	0.0458	7.4580	199.4326
0.0100	0.0496	7.5391	162.1315
0.0105	0.0533	7.6036	129.1533
0.0110	0.0572	7.6537	100.0708
0.0115	0.0610	7.6911	74.8808
0.0120	0.0648	7.7178	53.3650
0.0125	0.0687	7.7354	35.3077
0.0130	0.0726	7.7459	20.9135

Table VIII. Predicted Translation Parameters - Standing  
 Position at Entrance - 49% Open, 7.5 psi

TWO-ROOM MODEL - V/A = 5.1 FT

SHOT 24-75-150, 7.5 PSI

TIME-SEC	DISTANCE-FT	VELOCITY-FT/SEC	ACCEL.-FT/SEC/SEC
0.0005	0.0013	5.0962	10192.3473
0.0010	0.0051	10.2664	10340.5206
0.0015	0.0115	15.1298	9726.6587
0.0020	0.0201	19.2966	8333.7259
0.0025	0.0306	22.8055	7017.6688
0.0030	0.0427	25.7083	5805.7643
0.0035	0.0562	28.0640	4711.4057
0.0040	0.0707	29.9368	3745.5104
0.0045	0.0860	31.3894	2905.1568
0.0050	0.1020	32.4827	2186.5613
0.0055	0.1184	33.2752	1585.0039
0.0060	0.1352	33.8197	1089.1154
0.0065	0.1522	34.1664	693.4219
0.0070	0.1693	34.3605	388.1500
0.0075	0.1865	34.4459	170.8279

Table VIII. (Cont'd) Predicted Translation Parameters - Standing Position at Entrance - 49% Open, 7.5 psi

TWO-ROOM MODEL - V/A = 8.54 FT

SHOT 24-75-150, 7.5 PSI

TIME-SEC	DISTANCE-FT	VELOCITY-FT/SEC	ACCEL.-FT/SEC/SEC
0.0005	0.0013	5.0962	10192.3473
0.0010	0.0051	10.2179	10243.3602
0.0015	0.0115	15.3504	10264.9989
0.0020	0.0204	20.2627	9824.6298
0.0025	0.0316	24.7331	8940.7791
0.0030	0.0450	28.7755	8084.9374
0.0035	0.0603	32.4080	7264.9489
0.0040	0.0773	35.6519	6487.7338
0.0045	0.0959	38.5286	5753.5103
0.0050	0.1158	41.0633	5069.2711
0.0055	0.1369	43.2806	4434.6606
0.0060	0.1590	45.2048	3848.3984
0.0065	0.1820	46.8605	3311.4246
0.0070	0.2058	48.2716	2822.2163
0.0075	0.2302	49.4614	2379.5105
0.0080	0.2552	50.4527	1982.7477
0.0085	0.2806	51.2671	1628.6264
0.0090	0.3064	51.9246	1315.1357
0.0095	0.3325	52.4442	1039.1599
0.0100	0.3588	52.8440	799.6025
0.0105	0.3853	53.1415	594.9012
0.0110	0.4120	53.3524	421.8093
0.0115	0.4387	53.4924	280.0587
0.0120	0.4654	53.5763	167.8248
0.0125	0.4922	53.6181	83.5477
0.0130	0.5190	53.6322	28.3408
0.0135	0.5459	53.6332	1.9305
0.0140	0.5727	53.6374	8.3504

Figure 19 compares the maximum predicted translational velocity at the entrance with the average dummy velocities measured. The important thing to notice is that higher translational velocities are predicted and measured for the longer fill time as seen from the case for the 20% open front compared to the 49% open front.

## V. SUMMARY AND CONCLUSIONS

This section will summarize the experiment and show some predictions for full size room shelters.

### A. Summary of Experiment

A 1/12th scale two-room shelter model was exposed to shock waves for a reflected position at the end of the BRL 24-Inch Shock Tube. Dummy models were placed in the first room of the model shelter and the motion caused by the shock wave filling process was observed with a high speed camera.

Pressure-time fill records were recorded by transducers in both rooms of the shelter model. Computer code predictions of the filling process were made and compared to the experimental filling. Some translational parameters were predicted for the position near the entrance and compared to the observed motion of the model dummy which had been positioned on the centerline of the room.

Table IX summarizes the experimental cases tested and lists the cases of corresponding full size predictions. The latter are described in the next section.

### B. Predictions for Full Size Shelters

Again, as for the shelter model, pressure-time filling predictions were made for a full size two-room shelter exposed to reflected blast pressure from an assumed 1-MT source. Reference 4 was used as a guide for an assumed wave form and duration at each of the input pressure levels of 3, 7, and 10 psi before reflection.

Figures 20 - 25 are plots of these input waves and the predicted pressure-time filling as given in the tables of Appendix C for other full size room shelters.

Again, as for the model dummy, maximum translation parameters for a 168-lb man were calculated for a position near the entrance. Tables X and XI list sample cases; the remaining tables are given in Appendix E.

<sup>4</sup>H. L. Brode, "A Review of Nuclear Explosion Phenomena Pertinent to Protective Construction," Rand Document No. R-425-PR ECD-AD 601139, Rand Corp., Los Angeles, California, May 1964.

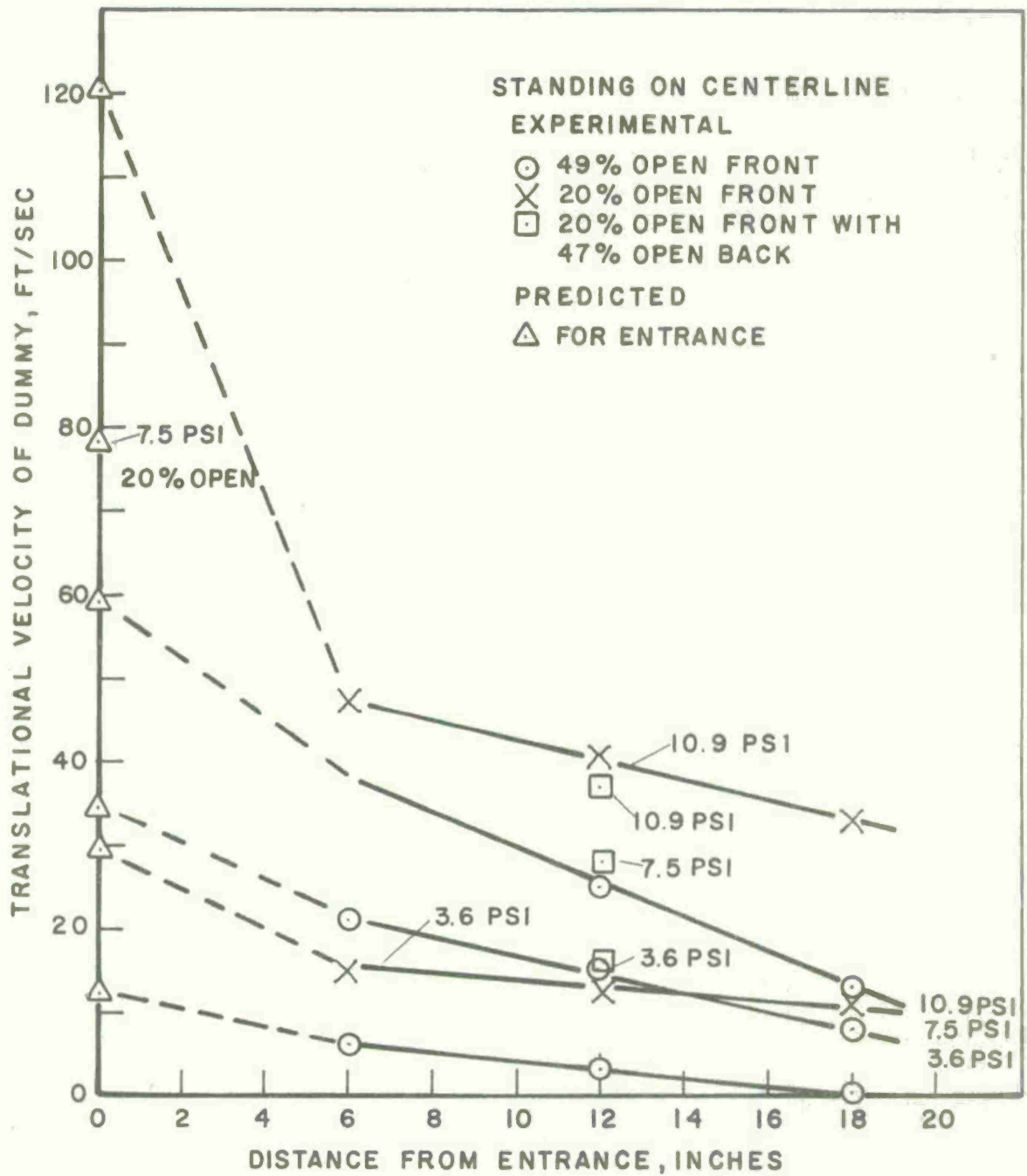
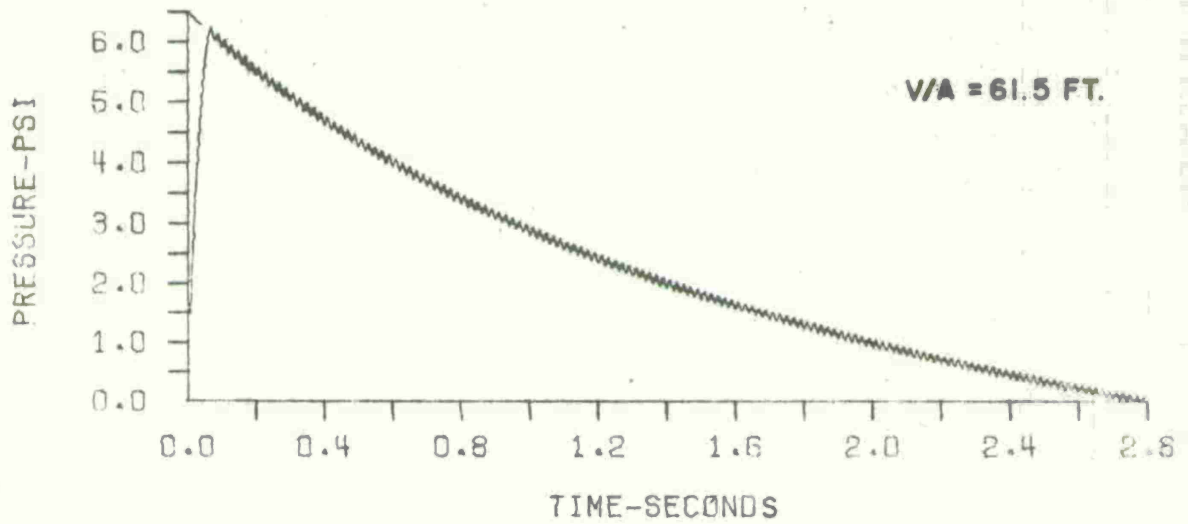


Figure 19. Translational Velocity of Model Dummy as a Function of Location on Floor

Table IX. Summary of Model and Shelter Parameters

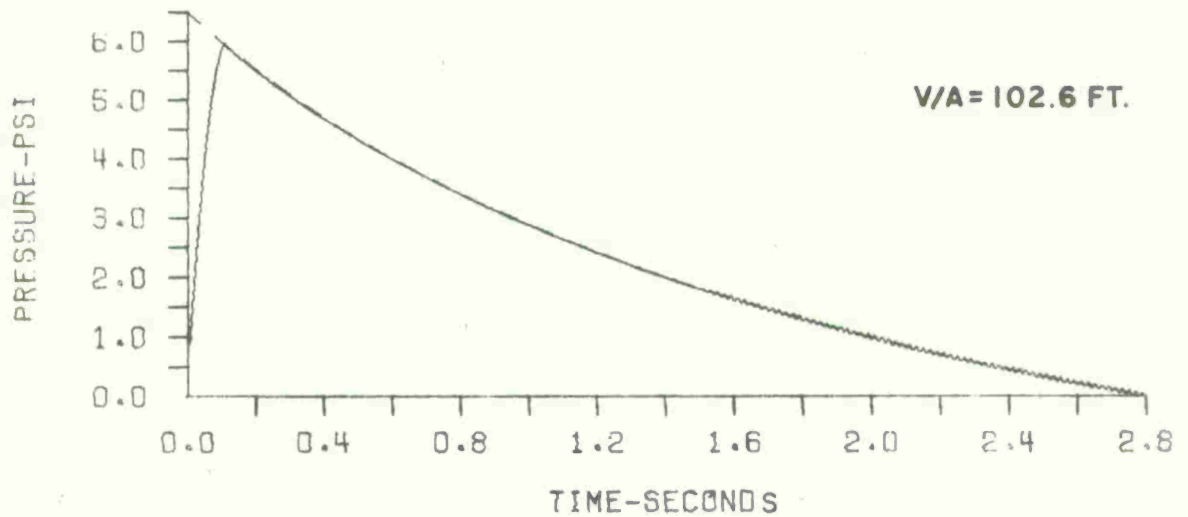
Model or Shelter	Input Pressure, psi	Size	Entrance Area	Volume Area, ft	Fill Time, sec	Remarks
Model-Front Room 49% Open Front	3.6 7.5 10.9	30 x 10 x 10 in.	97.5 in <sup>2</sup>	5.12	.0065 .0085 .0095	0.28 lb dummy
Model-Both Rooms 49% Open Front	3.6 7.5 10.9	50 x 20 x 10 in.	97.5 in <sup>2</sup>	8.54	.0115 .014 .0155	C <sub>D</sub> A = 0.013 ft <sup>2</sup> for prone. C <sub>D</sub> A = 0.10 ft <sup>2</sup> for standing
Model-Front Room 20% Open Front	3.6 7.5 10.9	30 x 10 x 10 in.	40.0 in <sup>2</sup>	12.5	.0175 .021 .023	
Model-Both Rooms 20% Open Front	3.6 7.5 10.9	50 x 20 x 10 in.	40.0 in <sup>2</sup>	20.83	.029 .035 .038	
Full Size Shelter Front Room-49% Open Front	3.0 7.0 10.0	30 x 20 x 10 ft	97.5 ft <sup>2</sup>	61.4	.075 .095 .100	168 lb man
Full Size Shelter Both Rooms-49% Open Front	3.0 7.0 10.0	50 x 20 x 10 ft	97.5 ft <sup>2</sup>	102.5	.115 .145 .155	C <sub>D</sub> A = 1.2 ft <sup>2</sup> for prone C <sub>D</sub> A = 9 ft <sup>2</sup> for standing
Full Size Shelter Front Room - 20% Open Front	3.0 7.0 10.0	30 x 20 x 10 ft	40 ft <sup>2</sup>	150	.165 .195 .215	1-MT blast wave
Full Size Shelter Both Rooms - 20% Open Front	3.0 7.0 10.0	50 x 20 x 10 ft	40 ft <sup>2</sup>	250	.255 .295 .315	

# CHAMBER FILL-BRL



(A) FRONT ROOM

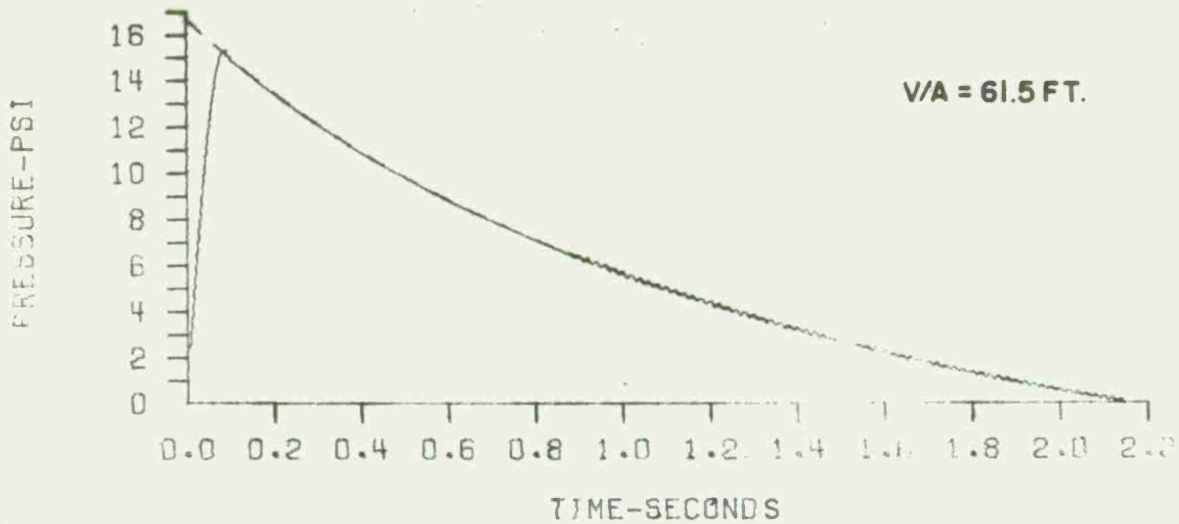
# CHAMBER FILL-BRL



(B) BOTH ROOMS

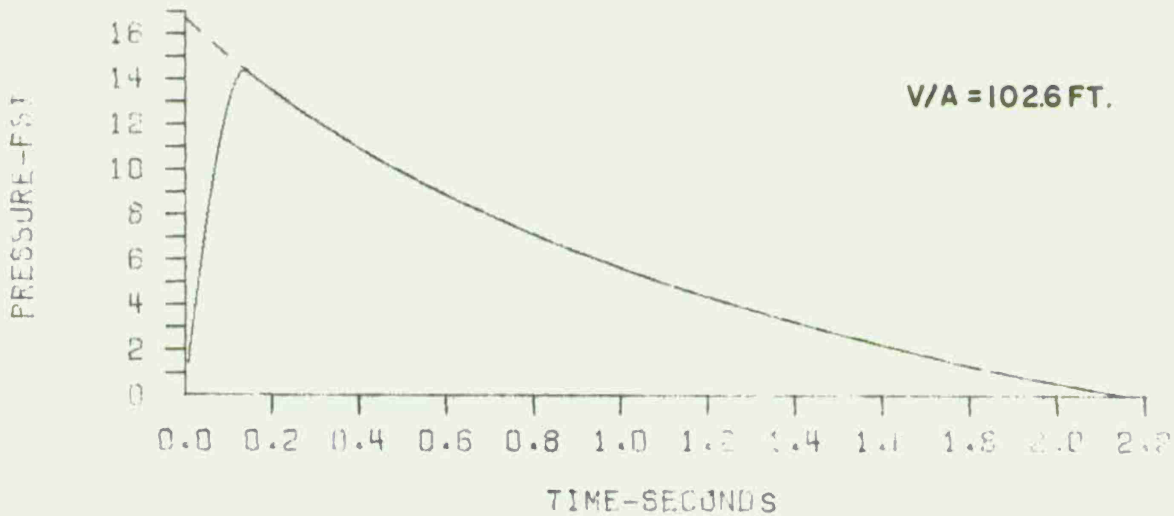
Figure 20. Fill Predictions for Full Size Shelter - 49% Opening, 3 psi

# CHAMBER FILL-BRL



(A) FRONT ROOM

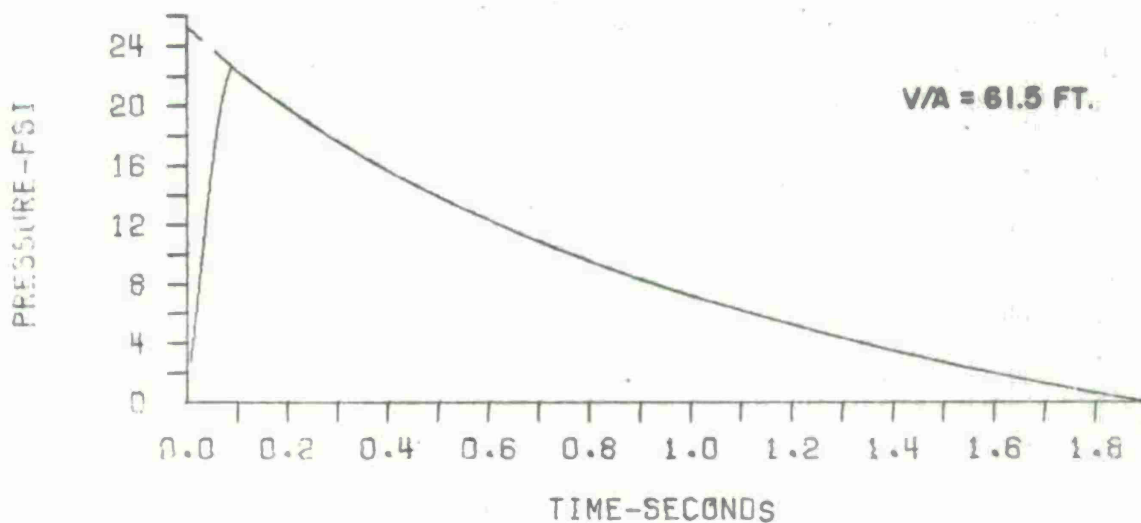
# CHAMBER FILL-BRL



(B) BOTH ROOMS

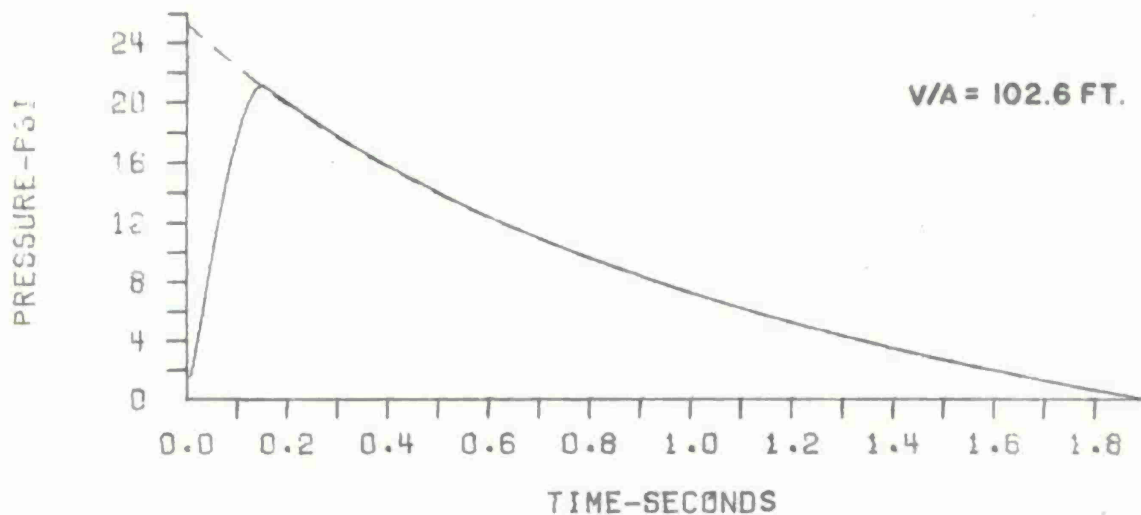
Figure 21. Fill Predictions for Full Size Shelter - 49% Opening, 7 psi

# CHAMBER FILL-BRL



(A) FRONT ROOM

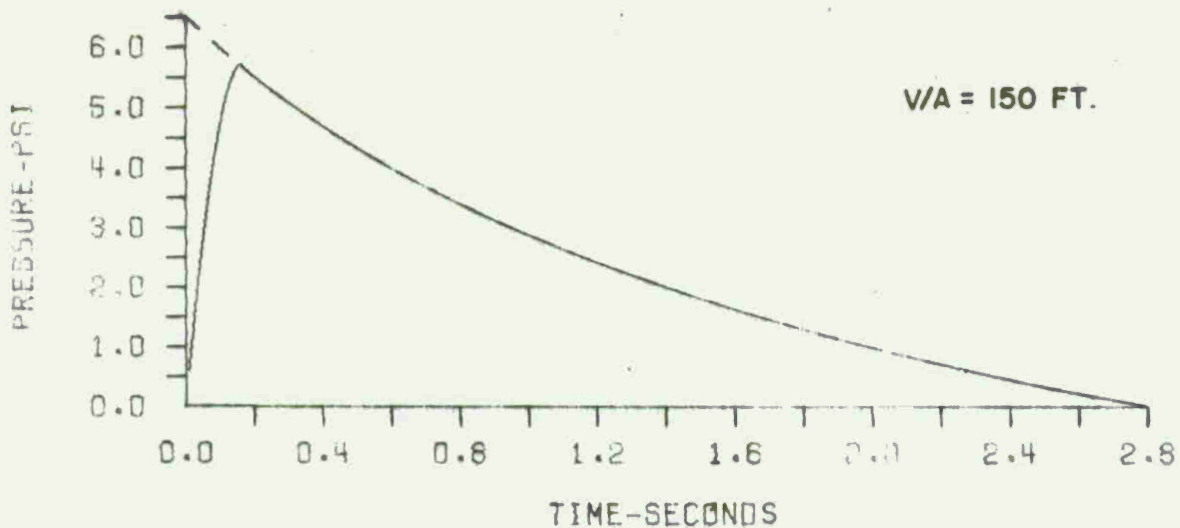
# CHAMBER FILL-BRL



(B) BOTH ROOMS

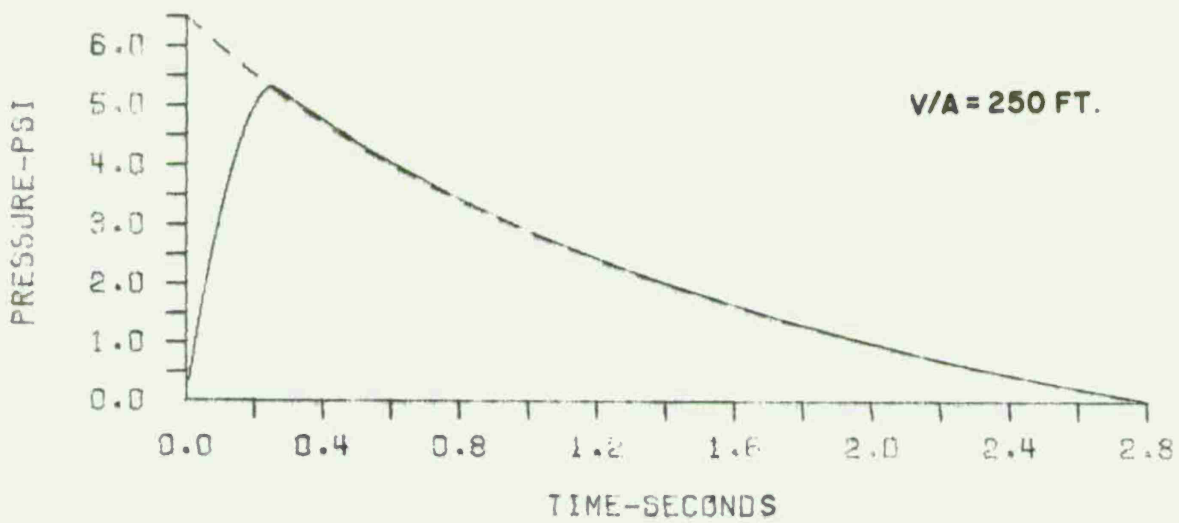
Figure 22. Fill Predictions for Full Size Shelter - 49% Opening, 10 psi

# CHAMBER FILL-BRL



(A) FRONT ROOM

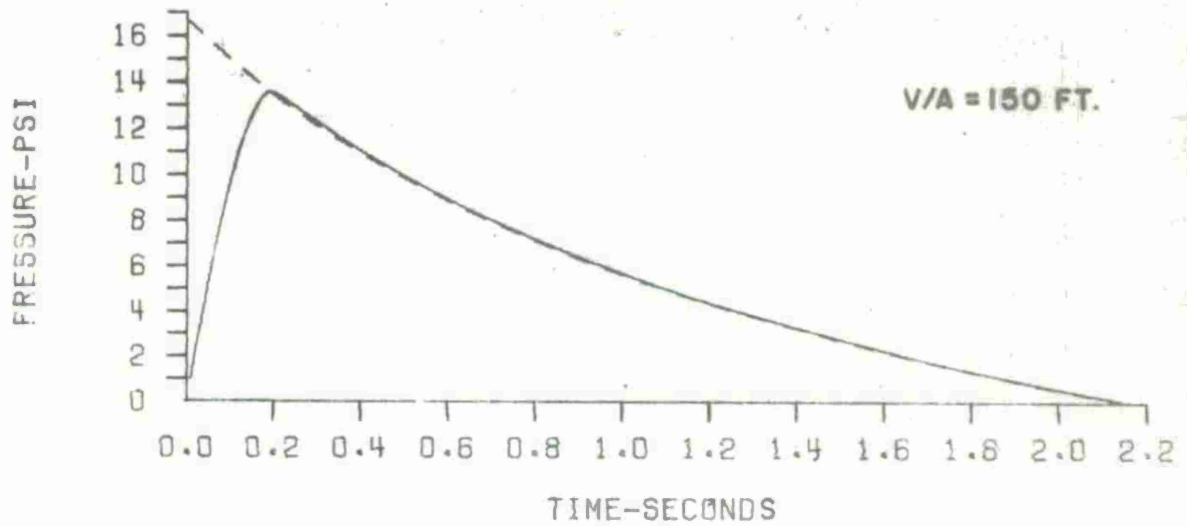
# CHAMBER FILL-BRL



(B) BOTH ROOMS

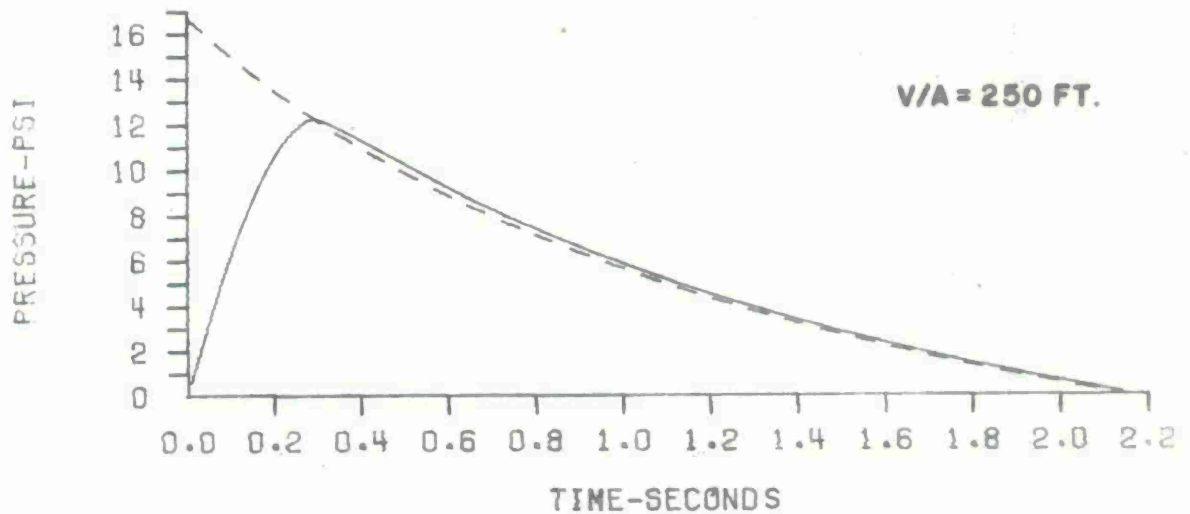
Figure 23. Fill Predictions for Full Size Shelter - 20% Opening, 3 psi

# CHAMBER FILL-BRL



(A) FRONT ROOM

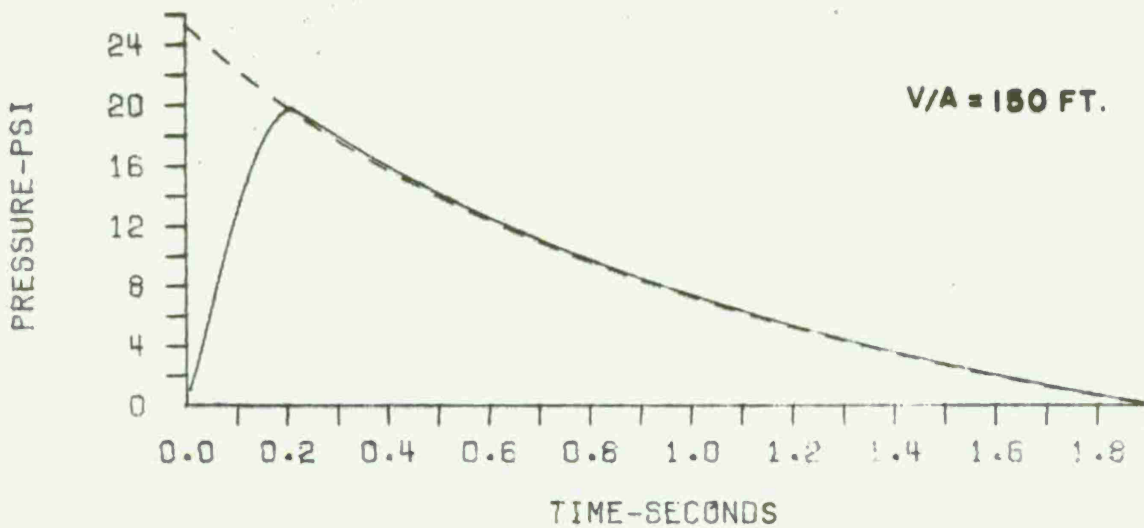
# CHAMBER FILL-BRL



(B) BOTH ROOMS

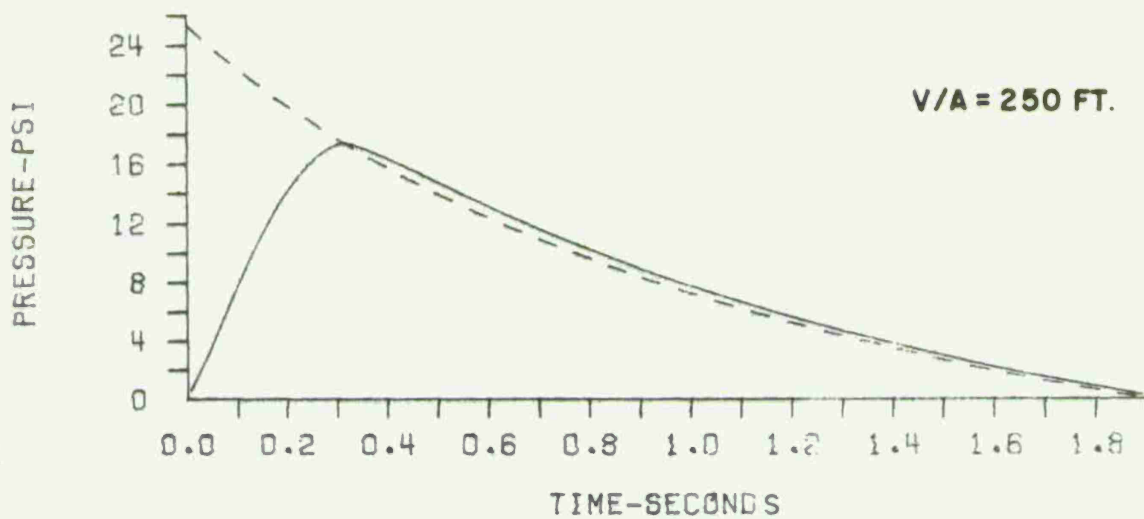
Figure 24. Fill Predictions for Full Size Shelter - 20% Opening, 7 psi

# CHAMBER FILL-BRL



**(A) FRONT ROOM**

# CHAMBER FILL-BRL



**(B) BOTH ROOMS**

Figure 25. Fill Predictions for Full Size Shelter - 20% Opening, 10 psi

Table X. Predicted Translation Parameters - Prone at Entrance -  
49% Open, 1-MT, 7 psi

TWO-ROOM SHELTER-V/A=61.5FT

1-MT, 7PSI

TIME-SEC	DISTANCE-FT	VELOCITY-FT/SEC	ACCEL.-FT/SEC/SEC
0.0100	0.0100	1.9954	199.5441
0.0200	0.0395	3.9151	191.9644
0.0300	0.0861	5.3905	147.5407
0.0400	0.1453	6.4632	107.2723
0.0500	0.2136	7.1945	73.1246
0.0600	0.2878	7.6512	45.6758
0.0700	0.3656	7.8981	24.6862

TWO-ROOM SHELTER-V/A=102.6FT

1-MT, 7PSI

TIME-SEC	DISTANCE-FT	VELOCITY-FT/SEC	ACCEL.-FT/SEC/SEC
0.0100	0.0100	1.9954	199.5441
0.0200	0.0401	4.0222	202.6736
0.0300	0.0892	5.8138	179.1606
0.0400	0.1550	7.3276	151.3803
0.0500	0.2345	8.5868	125.9230
0.0600	0.3255	9.6097	102.2864
0.0700	0.4257	10.4207	81.0994
0.0800	0.5330	11.0456	62.4959
0.0900	0.6458	11.5098	46.4177
0.1000	0.7625	11.8382	32.8342
0.1100	0.8820	12.0534	21.5273
0.1200	1.0031	12.1782	12.4758
0.1300	1.1252	12.2332	5.4969

Table XI. Predicted Translation Parameters - Standing at Entrance - 49% Open, 1-MT, 7 psi

TWO-ROOM SHELTER-V/A=61.5FT

1-MT, 7PSI

TIME-SEC	DISTANCE-FT	VELOCITY-FT/SEC	ACCEL.-FT/SEC/SEC
0.0100	0.0748	14.9658	1406.5804
0.0200	0.2981	28.8678	1300.1090
0.0300	0.6337	39.0644	1019.6611
0.0400	1.0594	46.0823	701.7892
0.0500	1.5426	50.5523	446.9988
0.0600	2.0608	53.0973	254.5065
0.0700	2.5977	54.2816	118.4241

TWO-ROOM SHELTER-V/A=102.6FT

1-MT, 7PSI

TIME-SEC	DISTANCE-FT	VELOCITY-FT/SEC	ACCEL.-FT/SEC/SEC
0.0100	0.0748	14.9658	1406.5804
0.0200	0.2981	29.6797	1471.3884
0.0300	0.6574	42.1881	1250.8392
0.0400	1.1209	52.3060	1011.7947
0.0500	1.6931	60.3334	802.7399
0.0600	2.3273	66.5194	618.5953
0.0700	3.0156	71.1368	461.7414
0.0800	3.7435	74.4485	331.1705
0.0900	4.4993	76.6975	224.8953
0.1000	5.2733	78.1086	141.1186
0.1100	6.0582	78.8815	77.2829
0.1200	6.8487	79.2053	32.3845
0.1300	7.6410	79.2630	5.7717

Figures 26 and 27 show the translational velocity for the prone and standing positions for the man. They have been calculated for the full entrance flow conditions as a function of the percentage of open front.

Again, the predicted velocities are higher for the longer fill times as seen from the case for the 20% open front.

#### ACKNOWLEDGMENTS

The author wishes to thank Messrs. W. Matthews, K. Holbrook and L. Blair for the experimental work performed at the BRL 24-Inch Shock Tube.

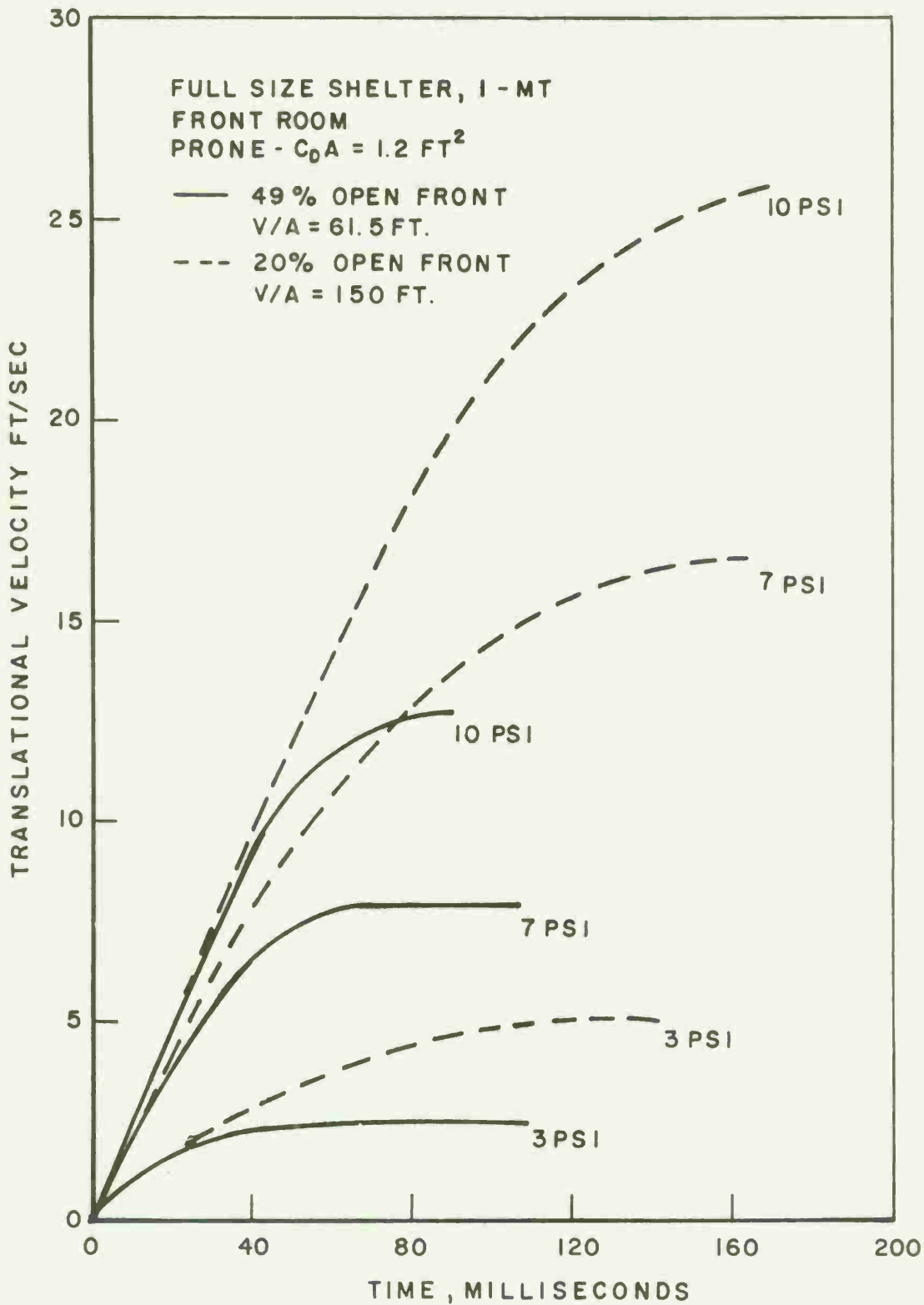


Figure 26. Predicted Translational Velocity for a 168-lb Man Prone at Entrance

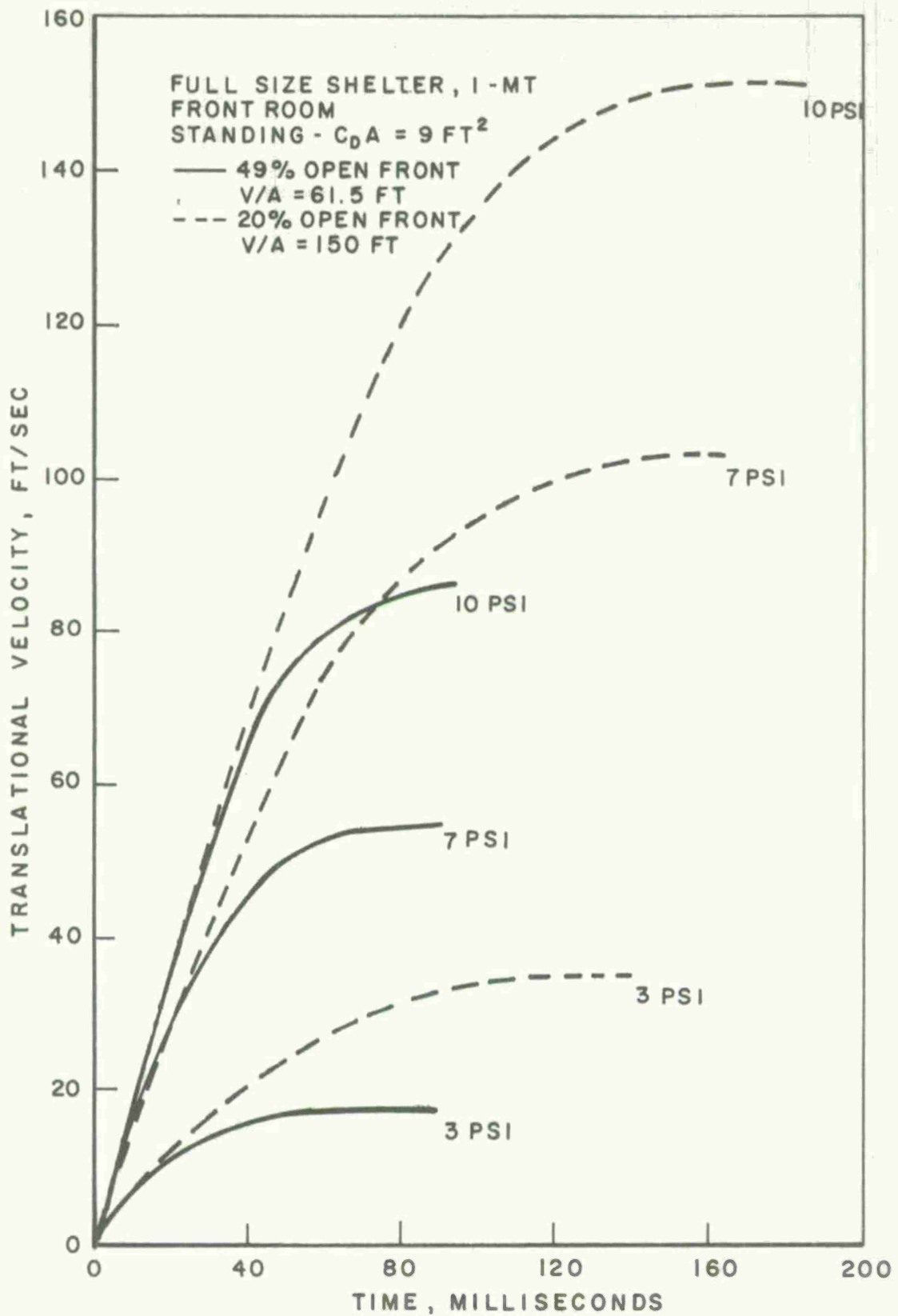
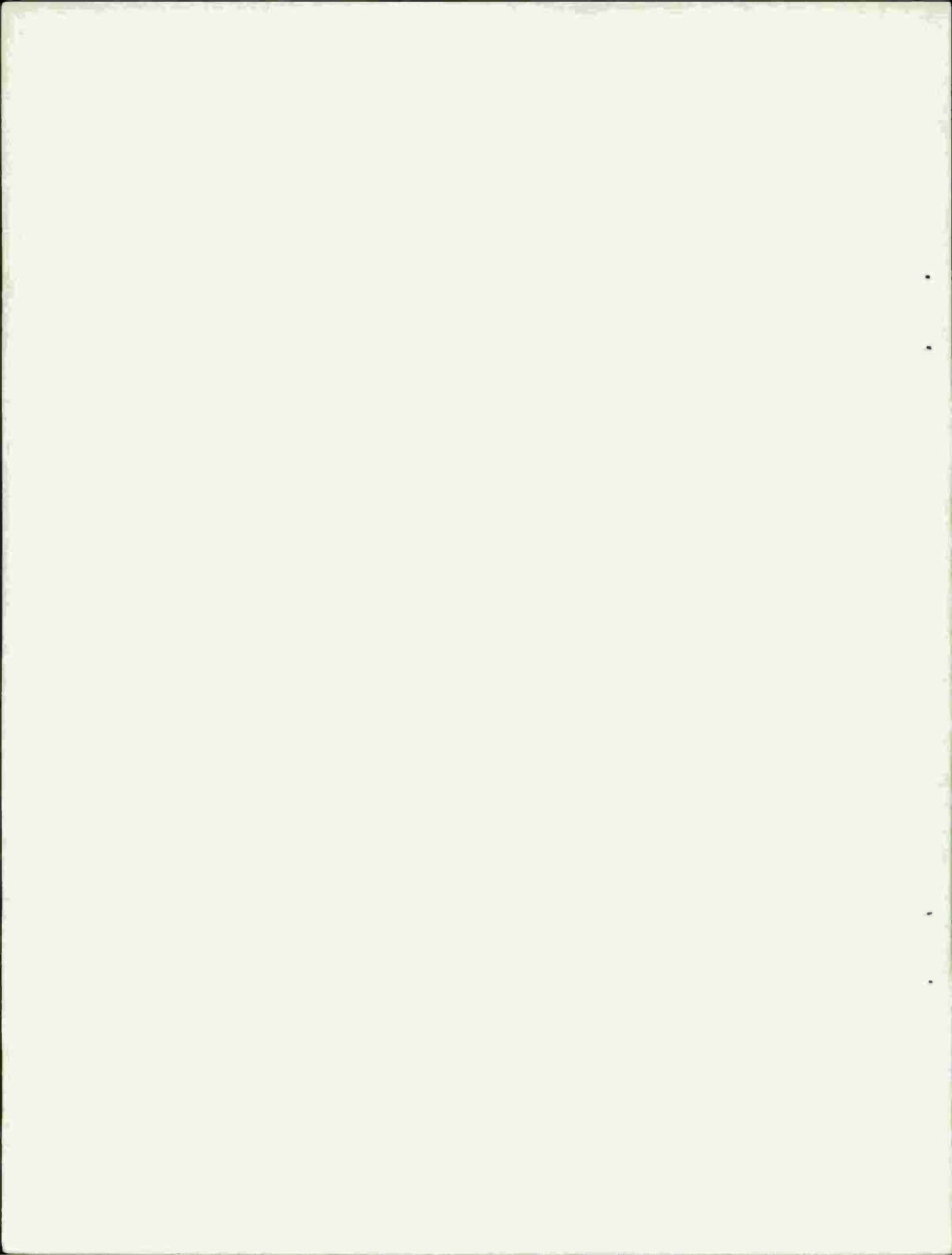


Figure 27. Predicted Translational Velocity for a 168-lb Man Standing at Entrance

## REFERENCES

1. George A. Coulter, "Blast Loading in Shelter Models - Basement and Mine Shelters," Ballistic Research Laboratories Memorandum Report No. 2476, April 1975, AD A010322.
2. George A. Coulter, "Blast Loading in Existing Structures - Basement Models," Ballistic Research Laboratories Memorandum Report No. 2208, August 1972, AD 751769.
3. E. F. Hoerner, "Fluid-Dynamic Drag," 148 Busted Drive, Midland Park, New Jersey 07432, published by author, 1965.
4. H. L. Brode, "A Review of Nuclear Explosion Phenomena Pertinent to Protective Construction," Rand Document No. R-425-PR ECD-AD 601139, Rand Corp., Los Angeles, California, May 1964.

APPENDIX A  
HIGH SPEED PHOTOGRAPHS



SHOT 24-75-148



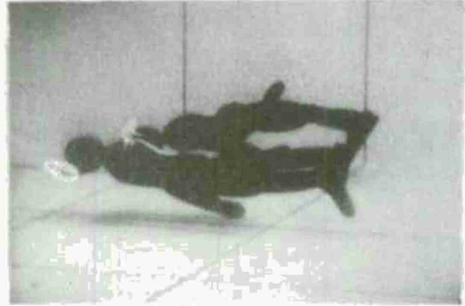





FRAME NUMBER	TIME, MSEC	FRAME NUMBER	TIME, MSEC
	0.2		44.4
	13.2		54.8
	23.6		75.6
	34.0		96.4

Figure A-1. 49% Open Front-Prone on 6-inch Line, 10.4 psi

SHOT 24-75-146

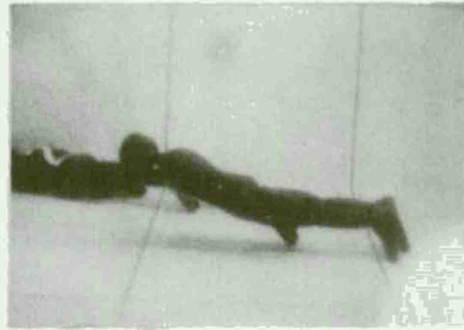
FRAME NUMBER      TIME, MSEC.

FRAME NUMBER      TIME, MSEC.



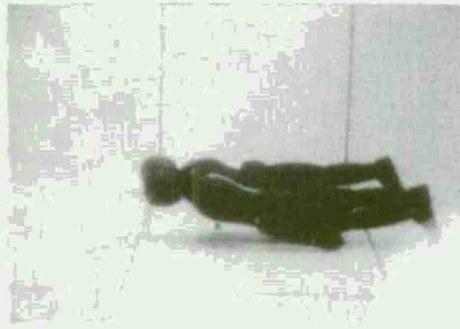
0

0.4



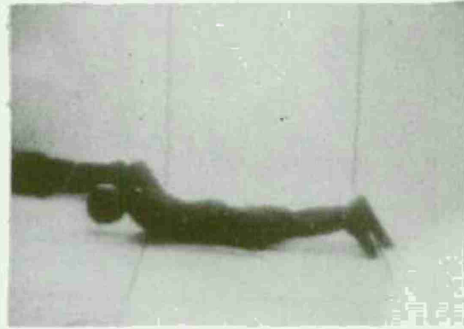
256

133.5



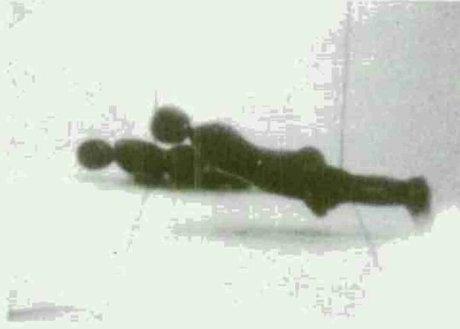
36

19.1



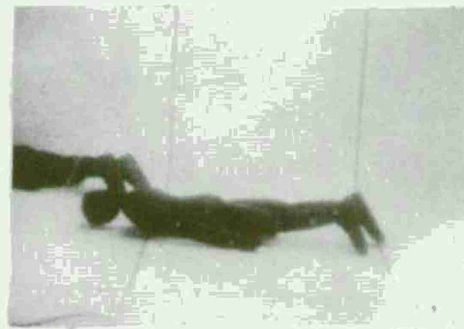
316

164.7



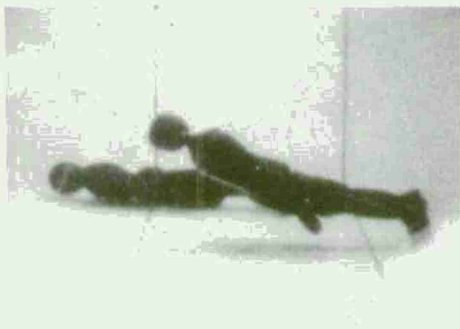
116

60.7



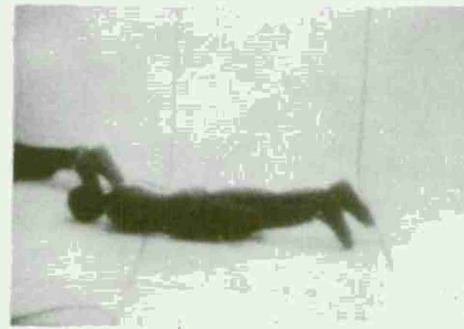
336

175.1



156

81.5



376

195.9

Figure A-2. 49% Open Front-Prone on 12-inch Line, 7.5 psi

SHOT 24-75-145

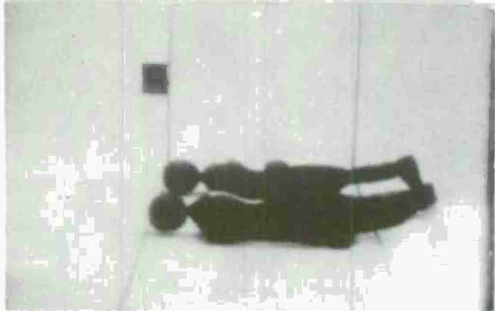
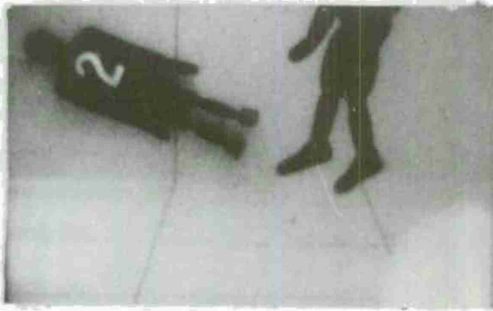
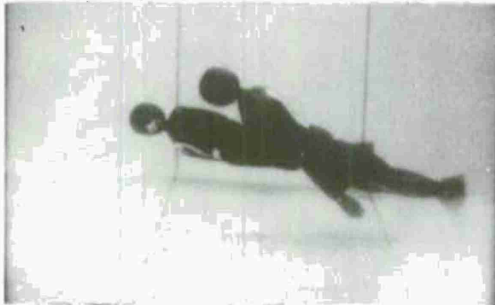
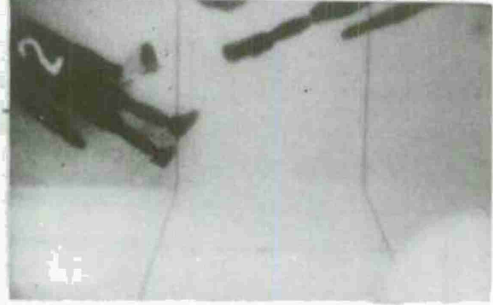

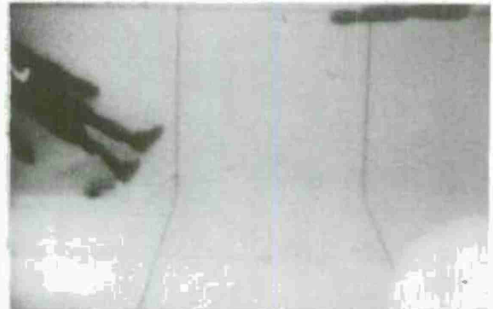

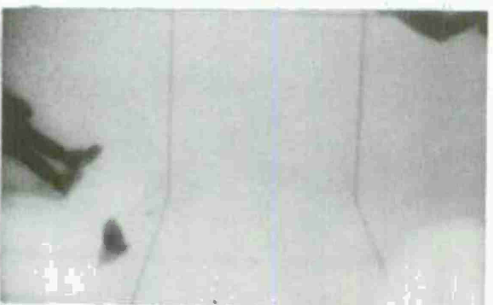
FRAME NUMBER	TIME, MSEC	FRAME NUMBER	TIME, MSEC		
	0	0.4		180	94.0
	60	31.6		260	135.6
	100	52.6		300	156.4
	140	73.2		360	187.6

Figure A-3. 49% Open Front-Prone on 12-inch Line, 11.1 psi



SHOT 24-75-151

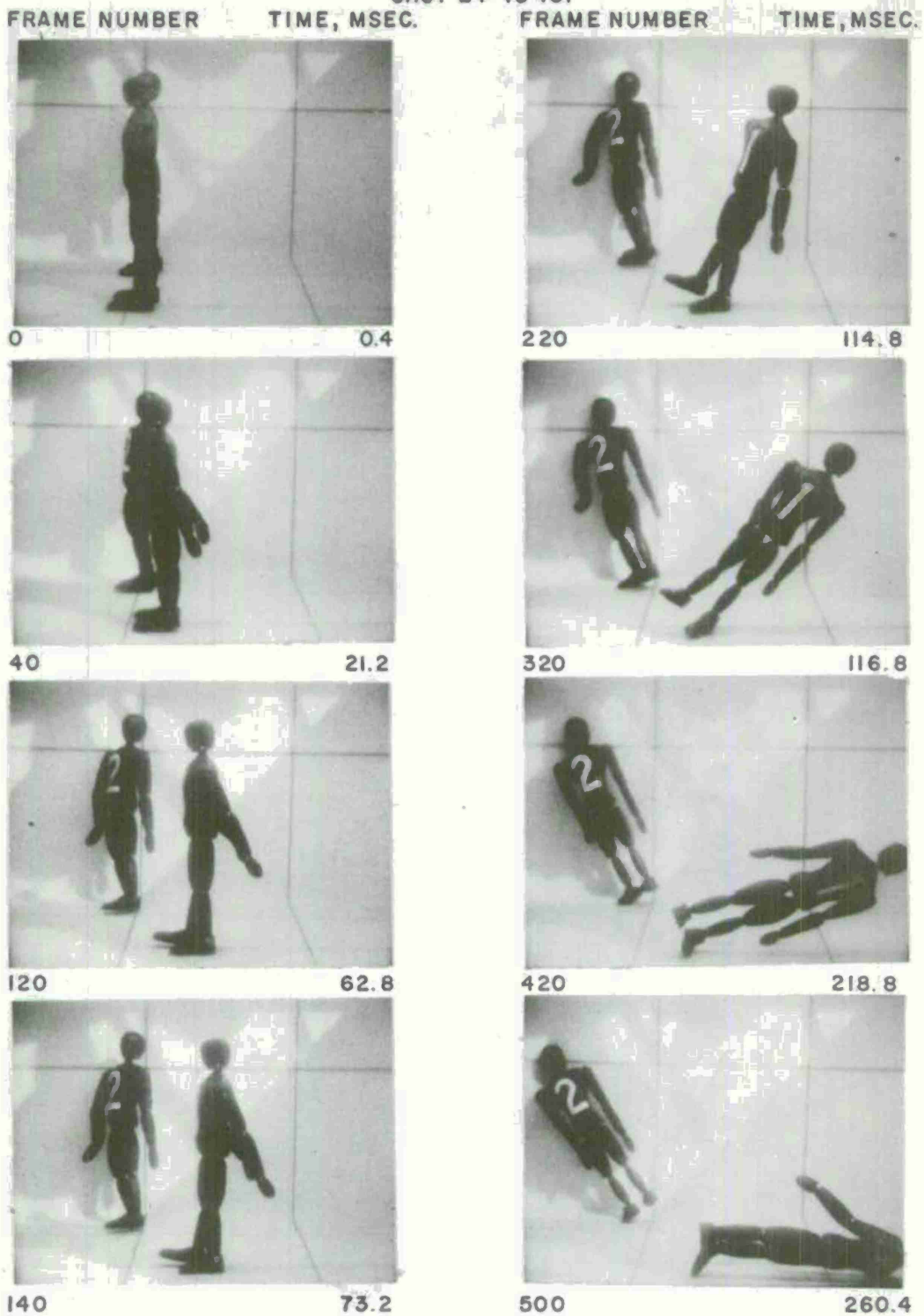


Figure A-5. 49% Open Front-Standing on 12-inch Line, 3.5 psi

SHOT 24-75-153

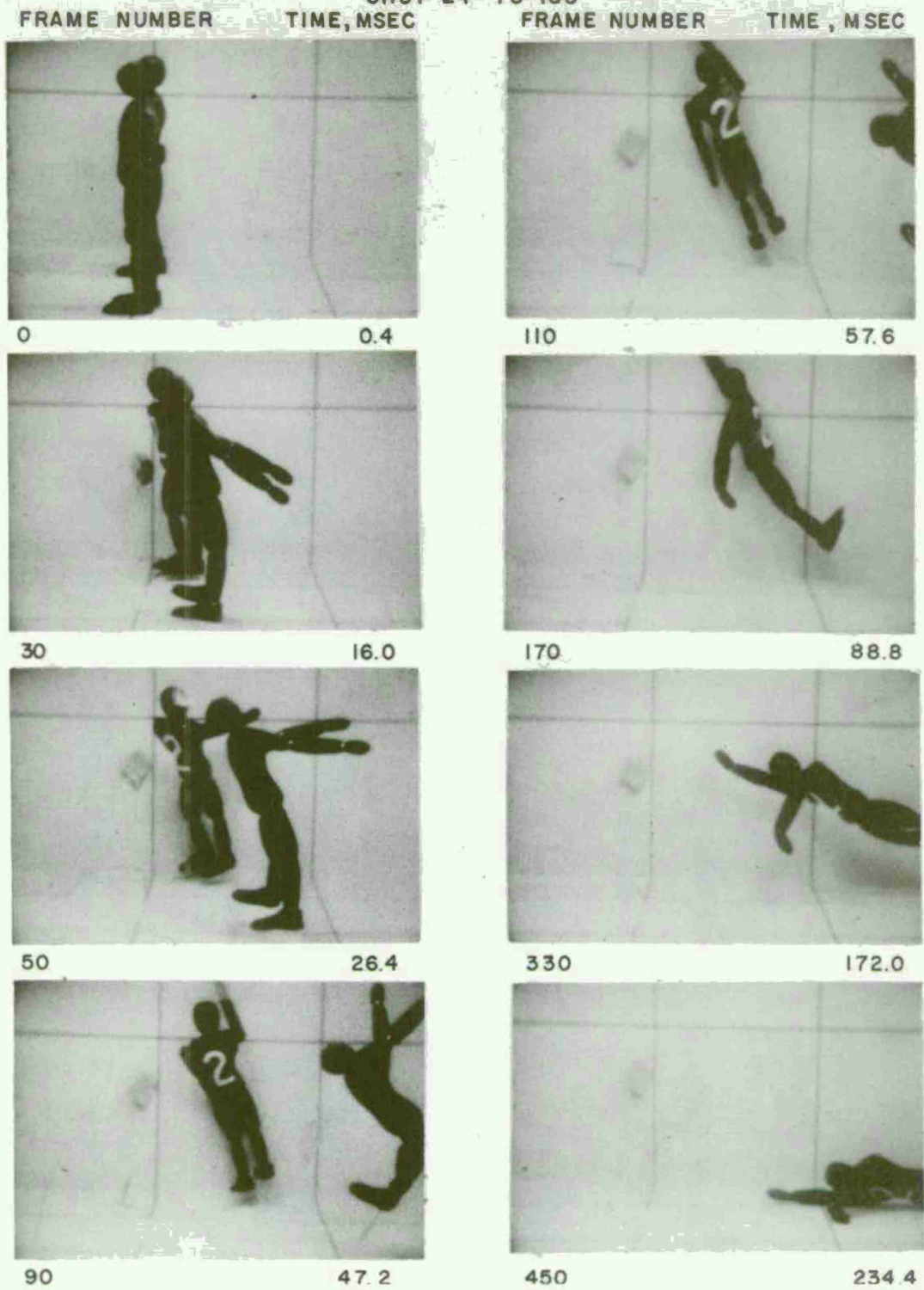


Figure A-6. 49% Open Front-Standing on 12-inch Line, 7.7 psi

SHOT 24-75-154

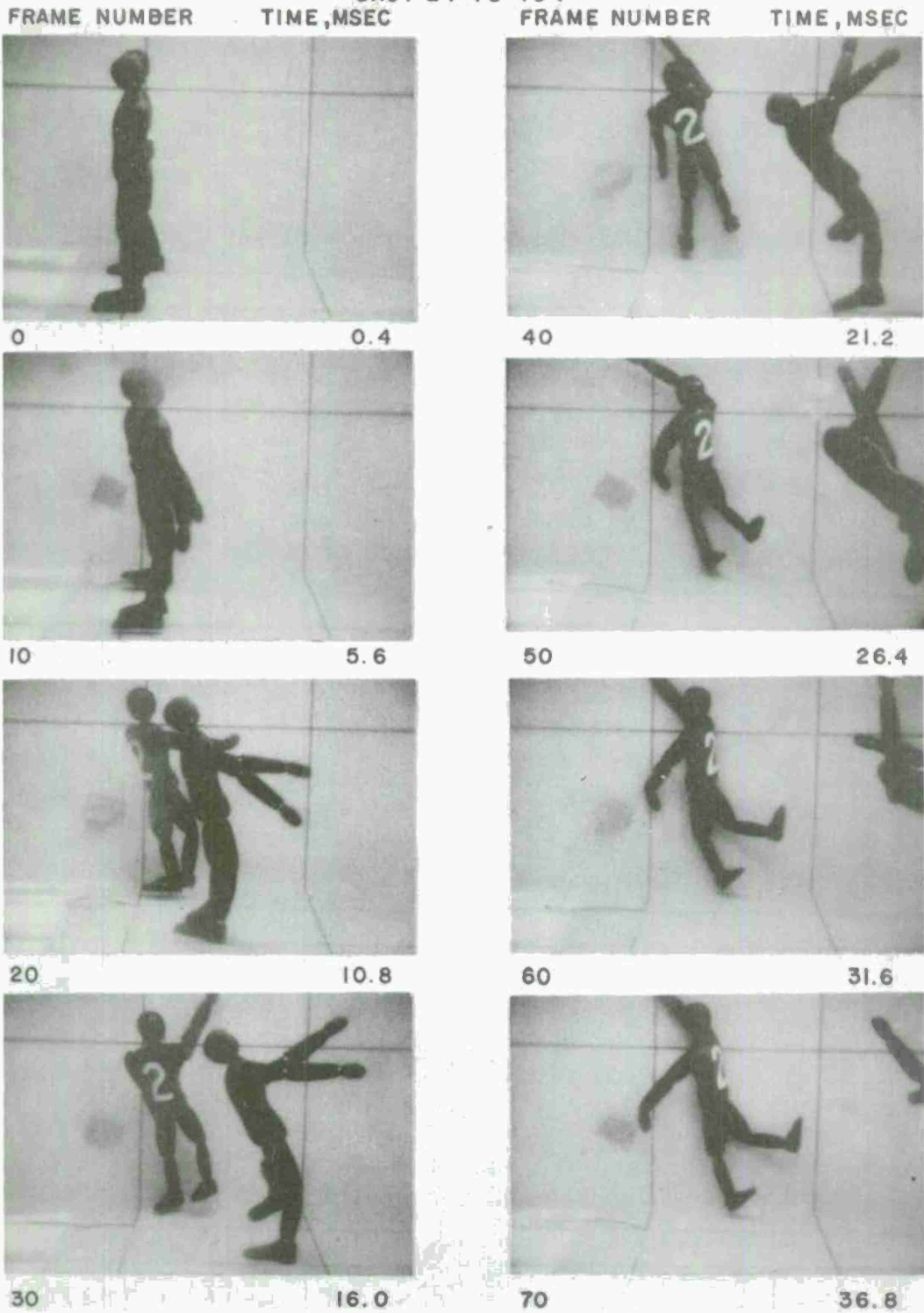
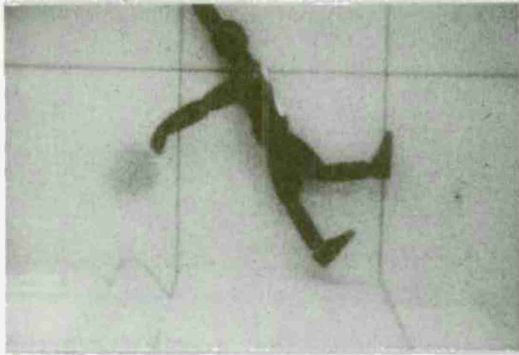


Figure A-7. 49% Open Front-Standing on 12-inch Line, 11.6 psi

SHOT 24-75-154

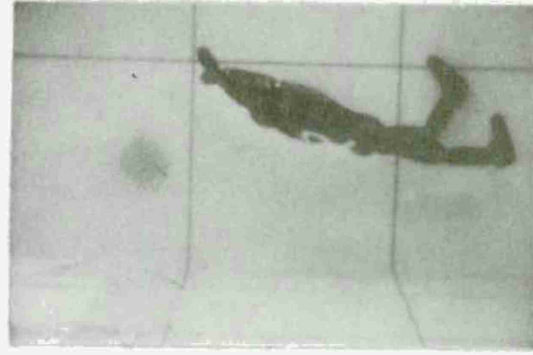
FRAME NUMBER      TIME, MSEC

FRAME NUMBER      TIME, MSEC



90

47.2



190

99.2



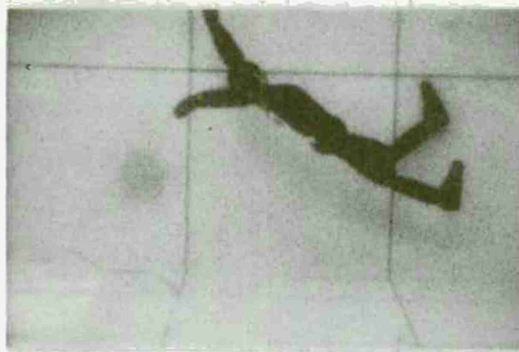
110

57.2



310

161.6



150

78.4



350

182.4

Figure A-7. (Cont'd) 49% Open Front-Standing on 12-inch Line, 11.6 psi

SHOT 24-75-167

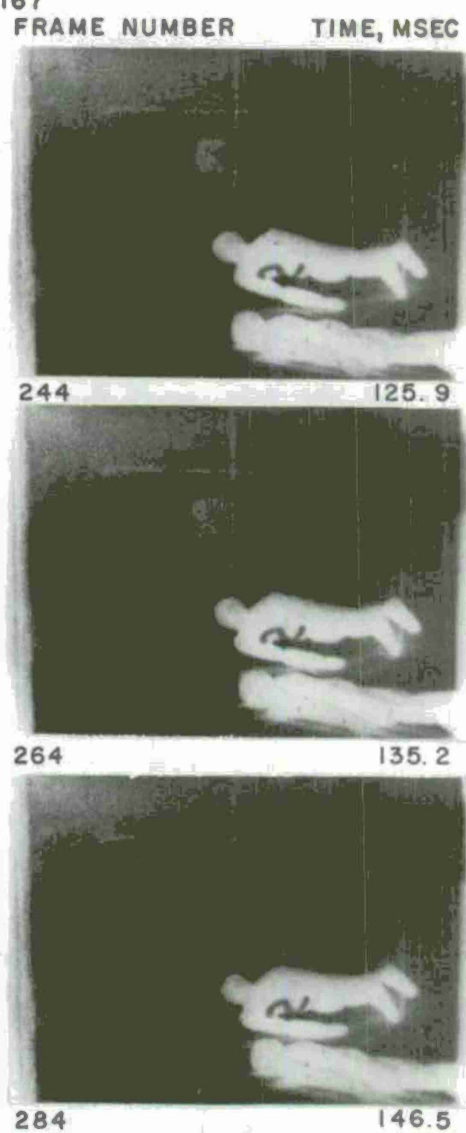
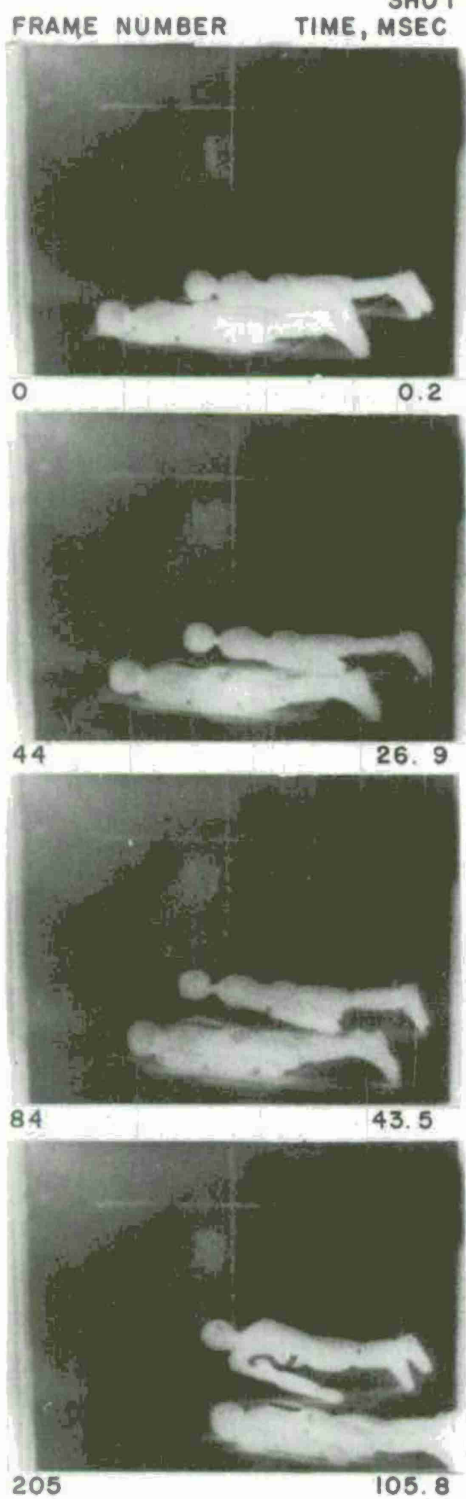


Figure A-8. 20% Open Front-Prone on 6-inch Line, 3.5 psi

SHOT 24-75-169

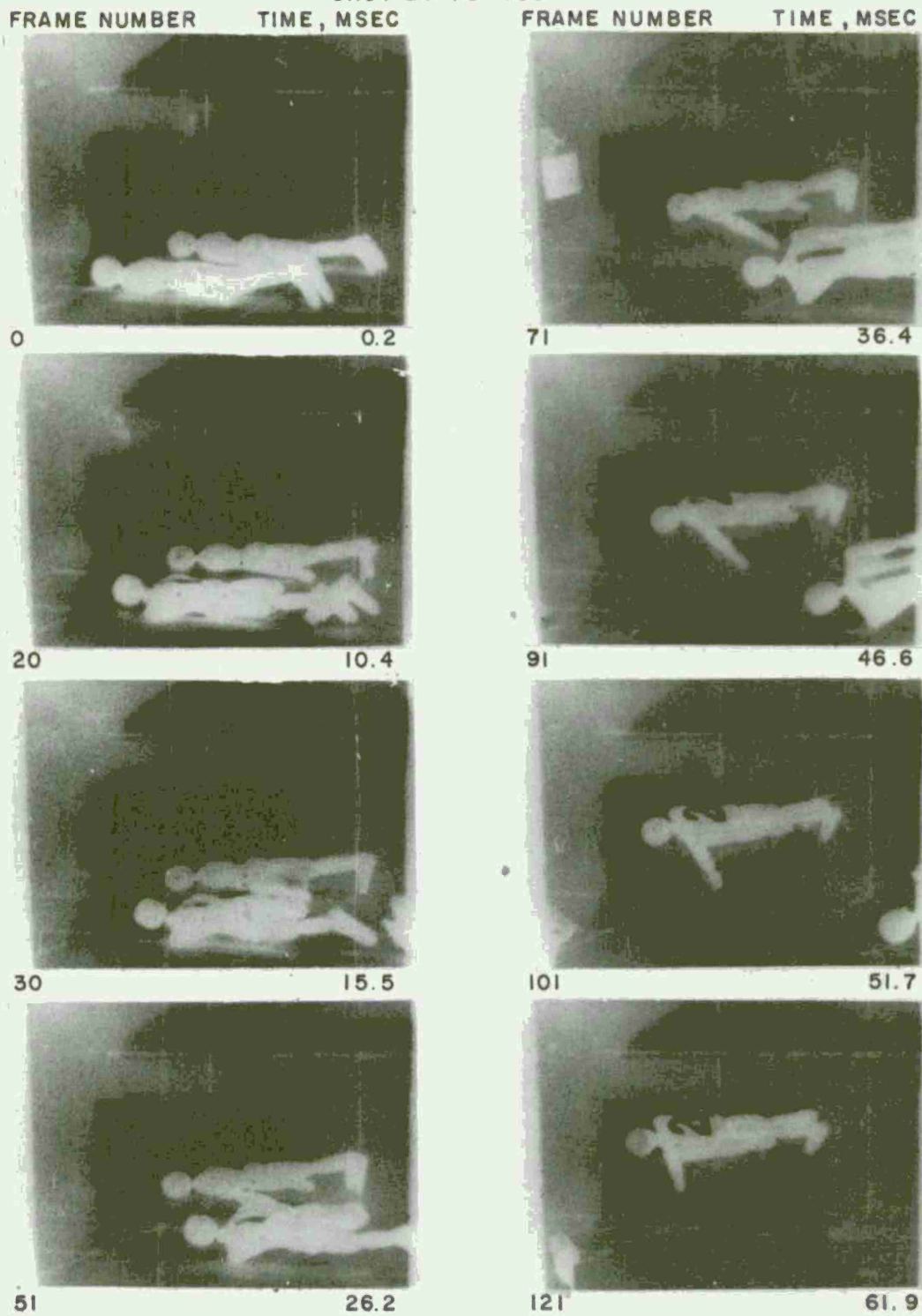
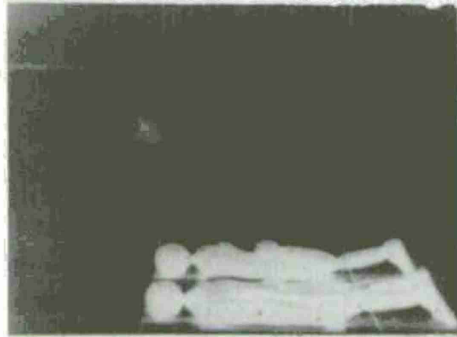


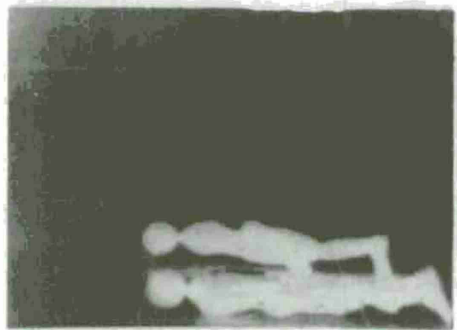
Figure A-9. 20% Open Front-Prone on 6-inch Line, 11.4 psi

SHOT 24-75-165

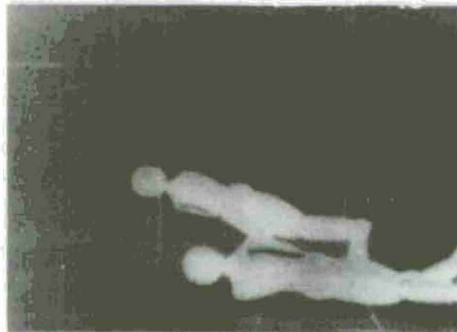
FRAME NUMBER      TIME, MSEC



0                      0.4



23                     12.4



43                     22.8



103                    54.0

FRAME NUMBER      TIME, MSEC



123                    64.4



163                    85.2



203                    106.2



243                    126.8

Figure A-10. 20% Open Front-Prone on 12-inch Line, 11.1 psi

SHOT 24-75-168

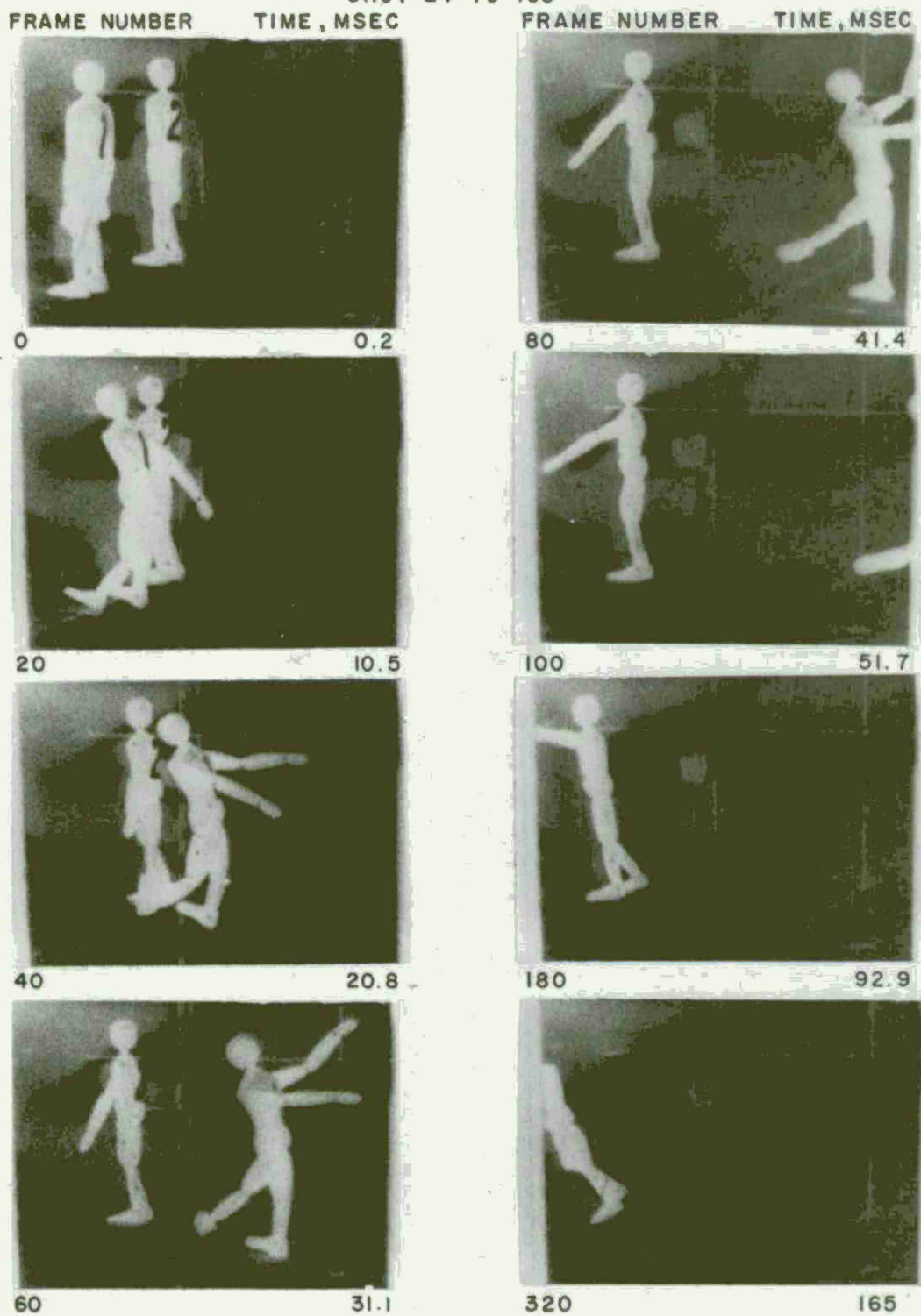


Figure A-11. 20% Open Front-Standing on 6-inch Line, 3.4 psi

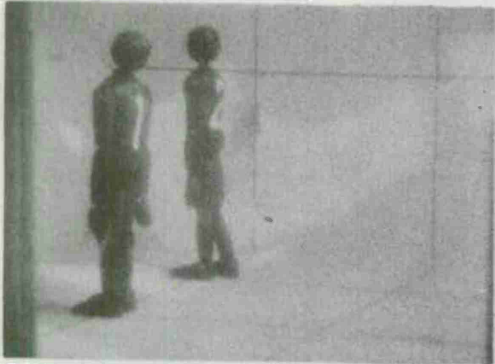
SHOT 24-75-170

FRAME NUMBER

TIME, MSEC

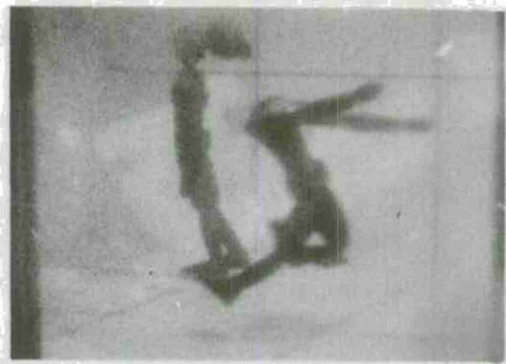
FRAME NUMBER

TIME, MSEC



0

0.2



15

7.9



10

5.3



25

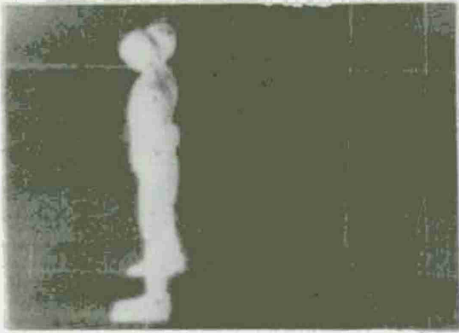
13.0

Figure A-12. 20% Open Front-Standing on 6-inch Line, 10.6 psi

SHOT 24-75-164

FRAME NUMBER TIME, MSEC

FRAME NUMBER TIME, MSEC



0

0.4



28

14.8



8

4.5



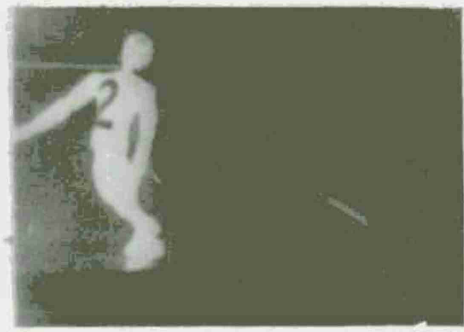
34

17.9



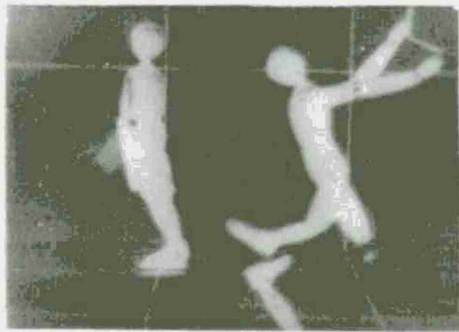
13

7.1



54

28.3



18

9.7



94

48.9

Figure A-13. 20% Open Front-Standing on 12-inch Line, 11.1 psi

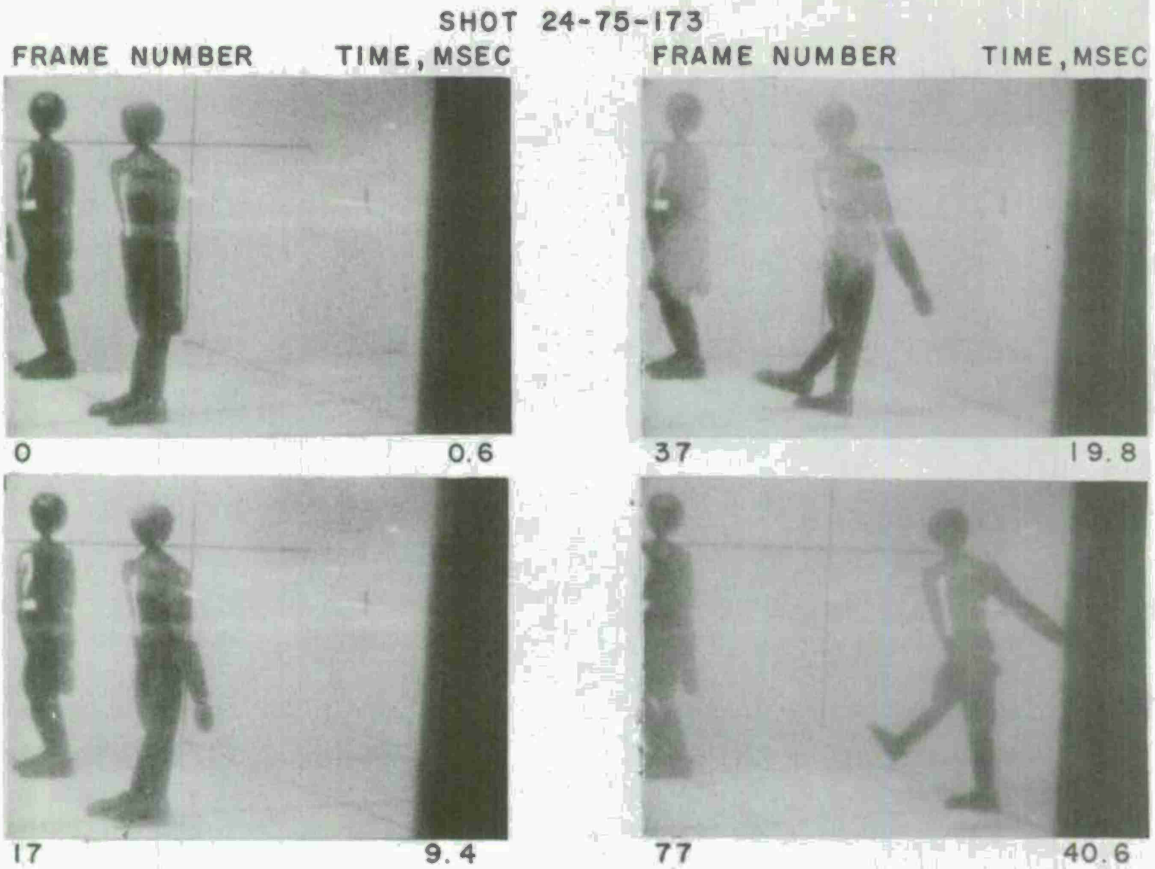
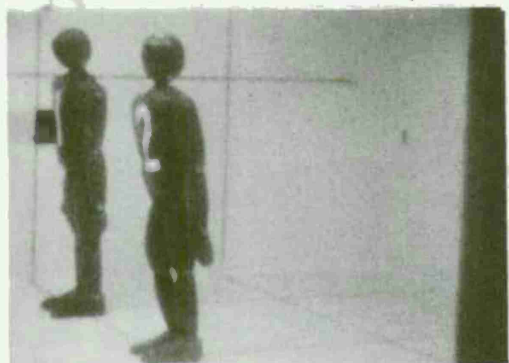


Figure A-14. 20% Open Front-Standing on 18-inch Line, 3.7 psi

SHOT 24-75-171

FRAME NUMBER      TIME, MSEC



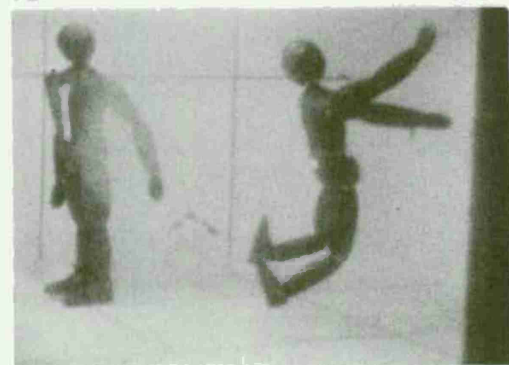
2

1.6



13

7.3



23

12.4

FRAME NUMBER      TIME, MSEC



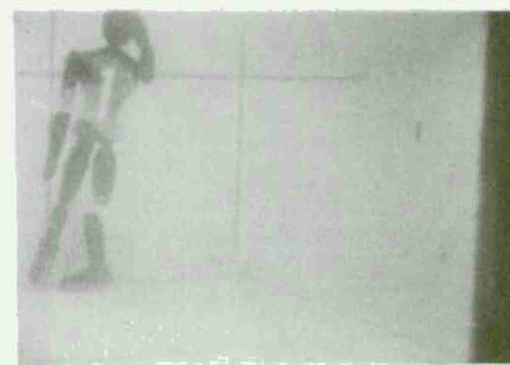
33

17.5



44

23.1



64

33.4

Figure A-15. 20% Open Front-Standing on 18-inch Line, 10.6 psi

SHOT 24-75-180

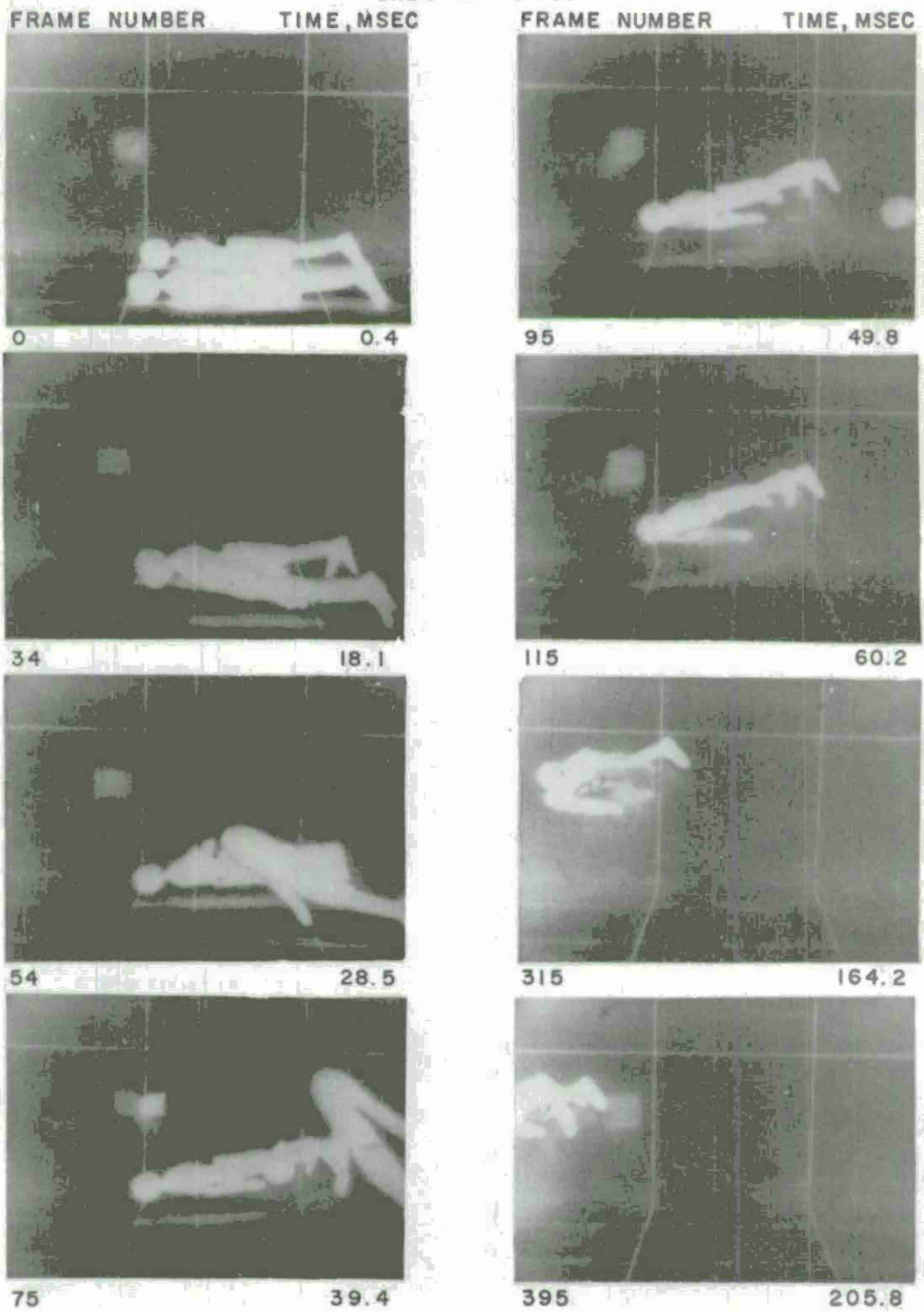


Figure A-16. 20% Open Front - 47% Open Back-Prone on 12-inch Line, 7.3 psi



SHOT 24-75-182

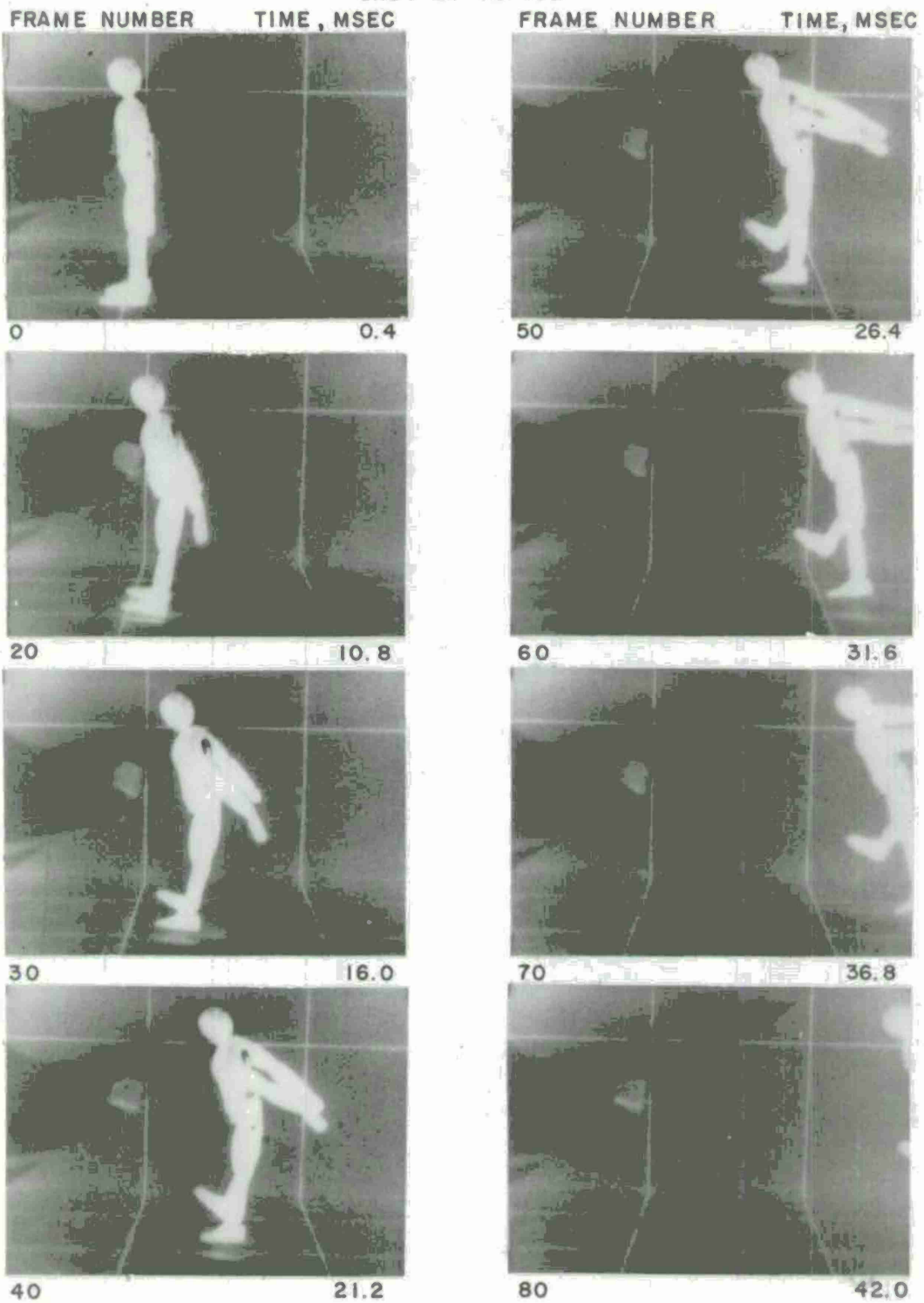


Figure A-18. 20% Open Front - 47% Open Back-Standing on 12-inch Line, 3.5 psi

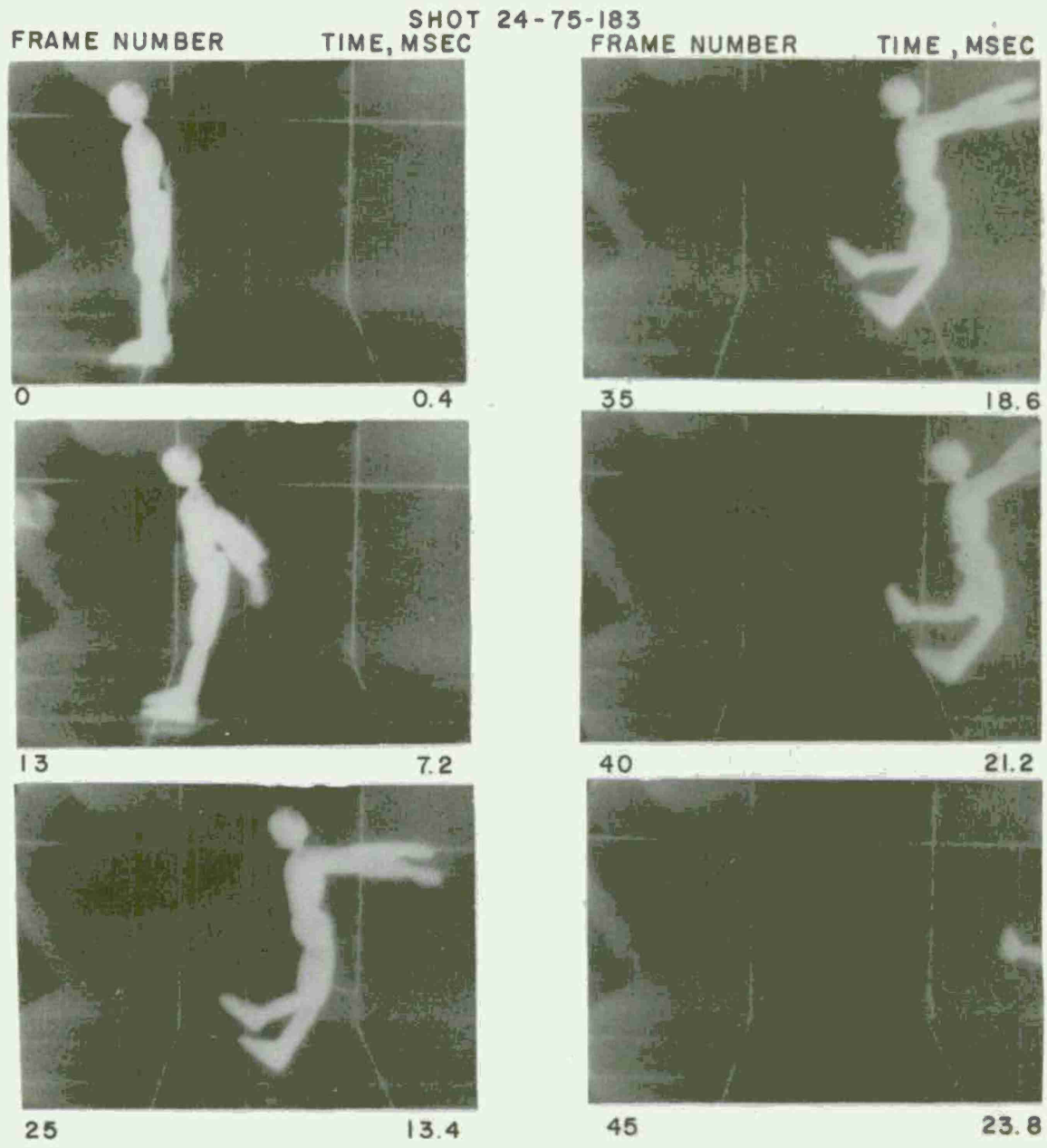


Figure A-19. 20% Open Front - 47% Open Back-Standing on 12-inch Line, 7.6 psi

APPENDIX B  
TABLES OF PREDICTED FILL PARAMETERS FOR MODEL

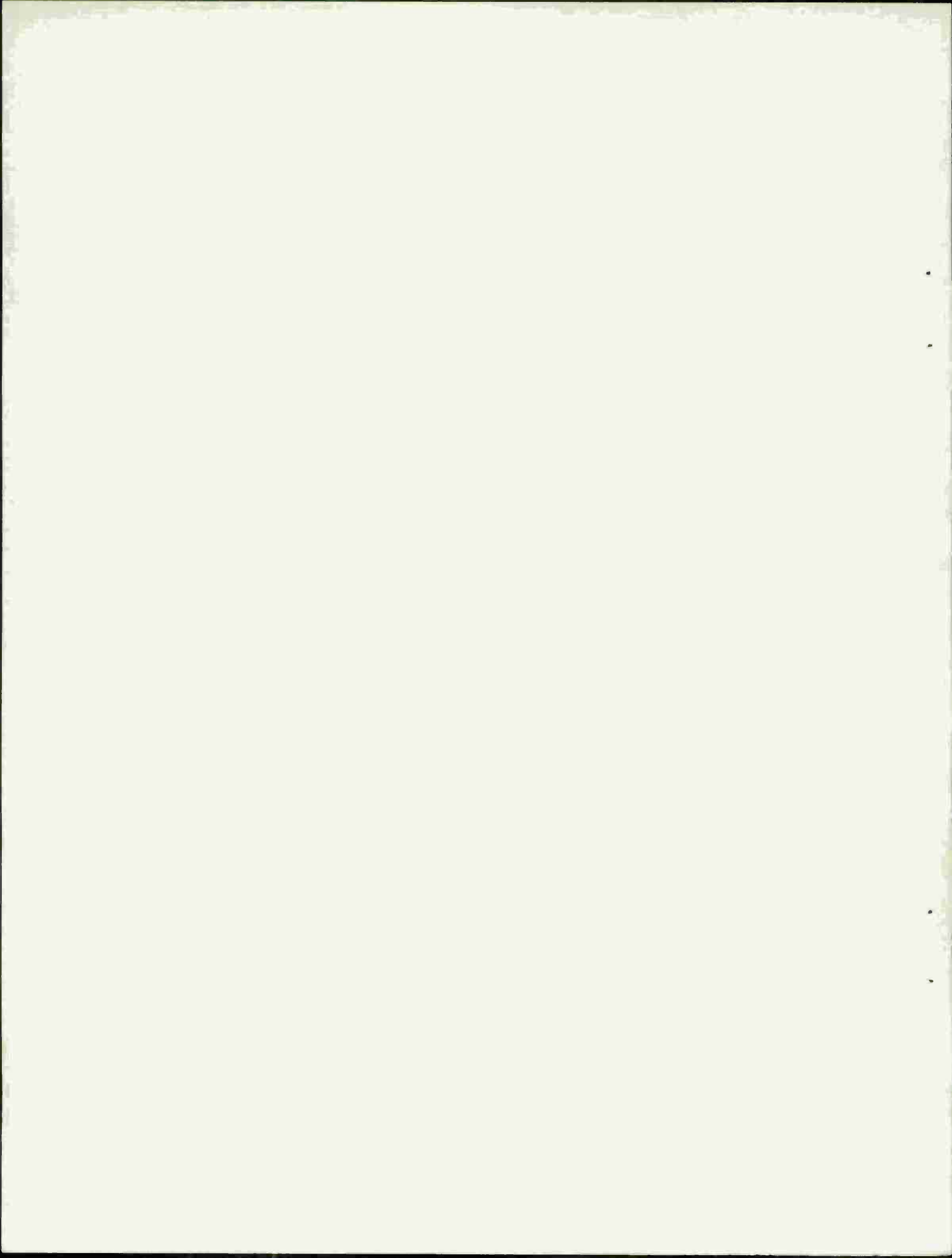


Table B-I. Fill-Time Prediction - 49% Open, 3.6 psi - Front Room

AREA1 0.677E 00	VOLUME 0.347200E 01	TIME 0.500000E-03	PRESSURE 0.150000E U2	DENSITY 0.318000E-02
TIME SECONDS	PRESSURE PSI	DENS UF-S2/F4	U2 FPS	DPT PSI
0.500E-03	0.104341E 01	0.245426E-02	0.631460E U3	0.324436E 01
0.100E-02	0.203017E 01	0.259069E-02	0.569171E U3	0.276556E 01
0.150E-02	0.295393E 01	0.271841E-02	0.510587E U3	0.232249E 01
0.200E-02	0.380967E 01	0.283673E-02	0.455484E U3	0.191932E 01
0.250E-02	0.459358E 01	0.294511E-02	0.403597E U3	0.155790E 01
0.300E-02	0.530275E 01	0.304316E-02	0.354625E U3	0.123837E 01
0.350E-02	0.593503E 01	0.313058E-02	0.308242E U3	0.959675E 00
0.400E-02	0.648873E 01	0.320714E-02	0.264092E U3	0.720049E 00
0.450E-02	0.696248E 01	0.327264E-02	0.221781E U3	0.517367E 00
0.500E-02	0.735487E 01	0.332689E-02	0.180856E U3	0.349447E 00
0.550E-02	0.766410E 01	0.336965E-02	0.140734E U3	0.214293E 00
0.600E-02	0.788708E 01	0.340047E-02	0.100490E U3	0.110337E 00
0.650E-02	0.801629E 01	0.341834E-02	0.578236E U2	0.367890E-01
0.700E-02	0.796894E 01	0.341131E-02	0.211131E U2	0.528821E-02
0.750E-02	0.803669E 01	0.342067E-02	0.302439E U2	0.100900E-01
0.800E-02	0.796558E 01	0.341012E-02	0.316972E U2	0.119197E-01
0.850E-02	0.803690E 01	0.341998E-02	0.318397E U2	0.111817E-01
0.900E-02	0.796558E 01	0.340939E-02	0.317916E U2	0.119883E-01
0.950E-02	0.803690E 01	0.341925E-02	0.318402E U2	0.111821E-01
0.100E-01	0.796557E 01	0.340866E-02	0.317950E U2	0.119883E-01
0.105E-01	0.803690E 01	0.341852E-02	0.318437E U2	0.111845E-01
0.110E-01	0.796556E 01	0.340794E-02	0.317985E U2	0.119884E-01
0.115E-01	0.803690E 01	0.341780E-02	0.318473E U2	0.111870E-01
0.120E-01	0.796556E 01	0.340722E-02	0.318020E U2	0.119885E-01
0.125E-01	0.803690E 01	0.341708E-02	0.318507E U2	0.111895E-01
0.130E-01	0.796555E 01	0.340650E-02	0.318054E U2	0.119886E-01
0.135E-01	0.803690E 01	0.341636E-02	0.318542E U2	0.111919E-01
0.140E-01	0.796554E 01	0.340578E-02	0.318089E U2	0.119887E-01
0.145E-01	0.803690E 01	0.341565E-02	0.318577E U2	0.111943E-01
0.150E-01	0.796553E 01	0.340506E-02	0.318124E U2	0.119888E-01
0.155E-01	0.803690E 01	0.341493E-02	0.318612E U2	0.111968E-01
0.160E-01	0.796553E 01	0.340435E-02	0.318158E U2	0.119889E-01
0.165E-01	0.803690E 01	0.341422E-02	0.318646E U2	0.111992E-01
0.170E-01	0.796552E 01	0.340364E-02	0.318192E U2	0.119889E-01
0.175E-01	0.803690E 01	0.341351E-02	0.318681E U2	0.112016E-01
0.180E-01	0.796551E 01	0.340293E-02	0.318227E U2	0.119890E-01
0.185E-01	0.803690E 01	0.341280E-02	0.318715E U2	0.112040E-01
0.190E-01	0.796550E 01	0.340222E-02	0.318261E U2	0.119891E-01
0.195E-01	0.803690E 01	0.341210E-02	0.318749E U2	0.112064E-01
0.200E-01	0.796550E 01	0.340152E-02	0.318295E U2	0.119892E-01
0.205E-01	0.803690E 01	0.341139E-02	0.318783E U2	0.112088E-01
0.210E-01	0.796549E 01	0.340082E-02	0.318329E U2	0.119893E-01
0.215E-01	0.803690E 01	0.341069E-02	0.318817E U2	0.112112E-01
0.220E-01	0.796548E 01	0.340012E-02	0.318362E U2	0.119894E-01
0.225E-01	0.803690E 01	0.340999E-02	0.318851E U2	0.112136E-01

Table B-II. Fill-Time Prediction - 49% Open, 3.6 psi - Rear Room

AREA1	VOLUME	TIME	PRESSURE	DENSITY
0.677E 00	0.578700E 01	0.500000E-03	0.150000E 02	0.318000E-02
TIME SECONDS	PRESSURE PSI	DENS HE-S2/F4	U2 FPS	DPT PSI
0.500E-03	0.626010E 00	0.239655E-02	0.631460E 03	0.324436E 01
0.100E-02	0.123235E 01	0.248039E-02	0.594015E 03	0.295607E 01
0.150E-02	0.181757E 01	0.256130E-02	0.557946E 03	0.267988E 01
0.200E-02	0.238042E 01	0.263912E-02	0.523211E 03	0.241697E 01
0.250E-02	0.291982E 01	0.271370E-02	0.489757E 03	0.216816E 01
0.300E-02	0.343484E 01	0.278490E-02	0.457531E 03	0.193397E 01
0.350E-02	0.392472E 01	0.285264E-02	0.426471E 03	0.171467E 01
0.400E-02	0.438881E 01	0.291680E-02	0.396417E 03	0.151028E 01
0.450E-02	0.482656E 01	0.297732E-02	0.367602E 03	0.132071E 01
0.500E-02	0.523754E 01	0.303415E-02	0.339660E 03	0.114569E 01
0.550E-02	0.562139E 01	0.308722E-02	0.312622E 03	0.984874E 00
0.600E-02	0.597781E 01	0.313650E-02	0.286416E 03	0.837846E 00
0.650E-02	0.630656E 01	0.318195E-02	0.260969E 03	0.704147E 00
0.700E-02	0.660745E 01	0.322355E-02	0.236205E 03	0.583295E 00
0.750E-02	0.688027E 01	0.326127E-02	0.212045E 03	0.474807E 00
0.800E-02	0.712487E 01	0.329509E-02	0.188406E 03	0.378216E 00
0.850E-02	0.734103E 01	0.332498E-02	0.165193E 03	0.293079E 00
0.900E-02	0.752855E 01	0.335090E-02	0.142302E 03	0.218998E 00
0.950E-02	0.768709E 01	0.337282E-02	0.119602E 03	0.155629E 00
0.100E-01	0.781620E 01	0.339068E-02	0.969151E 02	0.102700E 00
0.105E-01	0.791512E 01	0.340435E-02	0.739506E 02	0.600384E-01
0.110E-01	0.798233E 01	0.341364E-02	0.500343E 02	0.276243E-01
0.115E-01	0.801299E 01	0.341788E-02	0.228018E 02	0.573763E-02
0.120E-01	0.798762E 01	0.341412E-02	0.188506E 02	0.421541E-02
0.125E-01	0.801328E 01	0.341766E-02	0.190794E 02	0.401787E-02
0.130E-01	0.798763E 01	0.341385E-02	0.190634E 02	0.431083E-02
0.135E-01	0.801328E 01	0.341740E-02	0.190737E 02	0.401549E-02
0.140E-01	0.798763E 01	0.341359E-02	0.190640E 02	0.431074E-02
0.145E-01	0.801328E 01	0.341714E-02	0.190745E 02	0.401581E-02
0.150E-01	0.798763E 01	0.341333E-02	0.190647E 02	0.431075E-02
0.155E-01	0.801328E 01	0.341688E-02	0.190752E 02	0.401613E-02
0.160E-01	0.798763E 01	0.341307E-02	0.190655E 02	0.431076E-02
0.165E-01	0.801328E 01	0.341661E-02	0.190760E 02	0.401645E-02
0.170E-01	0.798763E 01	0.341280E-02	0.190663E 02	0.431078E-02
0.175E-01	0.801328E 01	0.341635E-02	0.190768E 02	0.401677E-02
0.180E-01	0.798762E 01	0.341254E-02	0.190670E 02	0.431079E-02
0.185E-01	0.801328E 01	0.341609E-02	0.190775E 02	0.401709E-02
0.190E-01	0.798762E 01	0.341228E-02	0.190678E 02	0.431080E-02
0.195E-01	0.801328E 01	0.341583E-02	0.190783E 02	0.401741E-02
0.200E-01	0.798762E 01	0.341202E-02	0.190685E 02	0.431081E-02
0.205E-01	0.801328E 01	0.341557E-02	0.190790E 02	0.401773E-02
0.210E-01	0.798762E 01	0.341176E-02	0.190693E 02	0.431082E-02
0.215E-01	0.801328E 01	0.341531E-02	0.190798E 02	0.401805E-02
0.220E-01	0.798762E 01	0.341150E-02	0.190700E 02	0.431083E-02
0.225E-01	0.801328E 01	0.341505E-02	0.190805E 02	0.401836E-02
0.230E-01	0.798762E 01	0.341124E-02	0.190708E 02	0.431085E-02
0.235E-01	0.801328E 01	0.341479E-02	0.190813E 02	0.401868E-02
0.240E-01	0.798762E 01	0.341098E-02	0.190715E 02	0.431086E-02
0.245E-01	0.801328E 01	0.341453E-02	0.190820E 02	0.401900E-02

Table B-III, Fill-Time Prediction - 49% Open, 10.9 psi - Front Room

AREA1 0.677E 00	VOLUME 0.347200E 01	TIME 0.500000E-03	PRESSURE 0.150000E 02	DENSITY 0.504000E-02
TIME SECONDS	PRESSURE PSI	DENS UE-S2/F4	U2 FPS	DPT PSI
0.500E-03	0.174530E 01	0.252975E-02	0.972405E 03	0.761022E 01
0.100E-02	0.364963E 01	0.276343E-02	0.955909E 03	0.795574E 01
0.150E-02	0.571922E 01	0.301106E-02	0.937911E 03	0.827147E 01
0.200E-02	0.795879E 01	0.327244E-02	0.918350E 03	0.854912E 01
0.250E-02	0.103712E 02	0.354723E-02	0.897183E 03	0.878025E 01
0.300E-02	0.127672E 02	0.381860E-02	0.874998E 03	0.797341E 01
0.350E-02	0.150623E 02	0.407854E-02	0.740917E 03	0.685917E 01
0.400E-02	0.172331E 02	0.432440E-02	0.662124E 03	0.579759E 01
0.450E-02	0.192607E 02	0.455405E-02	0.588431E 03	0.481268E 01
0.500E-02	0.211307E 02	0.476584E-02	0.519543E 03	0.391890E 01
0.550E-02	0.228321E 02	0.495854E-02	0.455087E 03	0.312317E 01
0.600E-02	0.243568E 02	0.513122E-02	0.394625E 03	0.242689E 01
0.650E-02	0.256997E 02	0.528320E-02	0.337666E 03	0.182773E 01
0.700E-02	0.268533E 02	0.541397E-02	0.283667E 03	0.132117E 01
0.750E-02	0.278168E 02	0.552309E-02	0.232013E 03	0.901656E 00
0.800E-02	0.285847E 02	0.561007E-02	0.181948E 03	0.563603E 00
0.850E-02	0.291506E 02	0.567416E-02	0.132379E 03	0.302156E 00
0.900E-02	0.295008E 02	0.571372E-02	0.809839E 02	0.114127E 00
0.950E-02	0.295039E 02	0.571417E-02	0.913885E 00	0.146157E-04
0.100E-01	0.294692E 02	0.570971E-02	0.800669E 01	0.127186E-02
0.105E-01	0.295729E 02	0.572146E-02	0.239160E 02	0.100046E-01
0.110E-01	0.294229E 02	0.570221E-02	0.345465E 02	0.236819E-01
0.115E-01	0.295869E 02	0.572079E-02	0.378490E 02	0.250386E-01
0.120E-01	0.294231E 02	0.569977E-02	0.377420E 02	0.282558E-01
0.125E-01	0.295869E 02	0.571832E-02	0.378072E 02	0.249833E-01
0.130E-01	0.294231E 02	0.569730E-02	0.377477E 02	0.282522E-01
0.135E-01	0.295869E 02	0.571586E-02	0.378160E 02	0.249950E-01
0.140E-01	0.294230E 02	0.569485E-02	0.377563E 02	0.282529E-01
0.145E-01	0.295869E 02	0.571342E-02	0.378247E 02	0.250064E-01
0.150E-01	0.294230E 02	0.569241E-02	0.377649E 02	0.282537E-01
0.155E-01	0.295869E 02	0.571098E-02	0.378333E 02	0.250178E-01
0.160E-01	0.294230E 02	0.568997E-02	0.377735E 02	0.282544E-01
0.165E-01	0.295869E 02	0.570855E-02	0.378419E 02	0.250291E-01
0.170E-01	0.294229E 02	0.568755E-02	0.377820E 02	0.282552E-01
0.175E-01	0.295869E 02	0.570612E-02	0.378504E 02	0.250405E-01
0.180E-01	0.294229E 02	0.568513E-02	0.377905E 02	0.282559E-01
0.185E-01	0.295869E 02	0.570371E-02	0.378590E 02	0.250517E-01
0.190E-01	0.294229E 02	0.568272E-02	0.377990E 02	0.282566E-01
0.195E-01	0.295869E 02	0.570130E-02	0.378675E 02	0.250630E-01
0.200E-01	0.294228E 02	0.568032E-02	0.378075E 02	0.282573E-01
0.205E-01	0.295870E 02	0.569890E-02	0.378760E 02	0.250742E-01
0.210E-01	0.294228E 02	0.567792E-02	0.378159E 02	0.282580E-01
0.215E-01	0.295870E 02	0.569651E-02	0.378845E 02	0.250854E-01
0.220E-01	0.294228E 02	0.567554E-02	0.378243E 02	0.282588E-01
0.225E-01	0.295870E 02	0.569413E-02	0.378929E 02	0.250966E-01

Table B-IV. Fill-Time Prediction - 49% Open, 10.9 psi - Rear Room

AREA1	VOLUME	TIME	PRESSURE	DENSITY
0.677E 00	0.578700E 01	0.500000E-03	0.150000E 02	0.504000E-02
TIME SECONDS	PRESSURE PSI	DEN3 UE-S2/F4	U2 FPS	DPT PSI
0.500E-03	0.104712E 01	0.244184E-02	0.972405E 03	0.761022E 01
0.100E-02	0.215201E 01	0.257878E-02	0.962508E 03	0.782428E 01
0.150E-02	0.331615E 01	0.272084E-02	0.952065E 03	0.802833E 01
0.200E-02	0.454084E 01	0.286799E-02	0.941063E 03	0.822052E 01
0.250E-02	0.582717E 01	0.302022E-02	0.929488E 03	0.839900E 01
0.300E-02	0.717599E 01	0.317745E-02	0.917330E 03	0.856186E 01
0.350E-02	0.858788E 01	0.333960E-02	0.904582E 03	0.870720E 01
0.400E-02	0.100588E 02	0.350620E-02	0.889266E 03	0.879415E 01
0.450E-02	0.115029E 02	0.366976E-02	0.836140E 03	0.811808E 01
0.500E-02	0.129141E 02	0.382958E-02	0.785000E 03	0.744759E 01
0.550E-02	0.142868E 02	0.398505E-02	0.735833E 03	0.679090E 01
0.600E-02	0.156162E 02	0.413562E-02	0.688607E 03	0.615465E 01
0.650E-02	0.168981E 02	0.428080E-02	0.643277E 03	0.554406E 01
0.700E-02	0.181289E 02	0.442020E-02	0.599783E 03	0.496300E 01
0.750E-02	0.193054E 02	0.455345E-02	0.558057E 03	0.441424E 01
0.800E-02	0.204251E 02	0.468027E-02	0.518018E 03	0.389956E 01
0.850E-02	0.214857E 02	0.480039E-02	0.479582E 03	0.341991E 01
0.900E-02	0.224856E 02	0.491364E-02	0.442657E 03	0.297560E 01
0.950E-02	0.234232E 02	0.501982E-02	0.407146E 03	0.256541E 01
0.100E-01	0.242973E 02	0.511882E-02	0.372948E 03	0.219173E 01
0.105E-01	0.251078E 02	0.521053E-02	0.339960E 03	0.185065E 01
0.110E-01	0.258515E 02	0.529485E-02	0.308073E 03	0.154206E 01
0.115E-01	0.265302E 02	0.537172E-02	0.277175E 03	0.126476E 01
0.120E-01	0.271426E 02	0.544108E-02	0.247150E 03	0.101750E 01
0.125E-01	0.276880E 02	0.550286E-02	0.217872E 03	0.799014E 00
0.130E-01	0.281661E 02	0.555700E-02	0.189203E 03	0.608134E 00
0.135E-01	0.285761E 02	0.560344E-02	0.160985E 03	0.443782E 00
0.140E-01	0.289172E 02	0.564207E-02	0.133018E 03	0.305037E 00
0.145E-01	0.291880E 02	0.567274E-02	0.105016E 03	0.191189E 00
0.150E-01	0.293861E 02	0.569517E-02	0.764724E 02	0.101828E 00
0.155E-01	0.295057E 02	0.570872E-02	0.460511E 02	0.370444E-01
0.160E-01	0.294805E 02	0.570549E-02	0.967740E 01	0.185620E-02
0.165E-01	0.295300E 02	0.571109E-02	0.190057E 02	0.631933E-02
0.170E-01	0.294723E 02	0.570369E-02	0.221510E 02	0.973414E-02
0.175E-01	0.295313E 02	0.571038E-02	0.226767E 02	0.899506E-02

Table V, Fill-Time Prediction - 20% Open, 3,6 psi - Front Room

AREA1	VOLUME	TIME	PRESSURE	DENSITY
TIME	PRESSURE	DEN3	U2	DPT
SECONDS	PSI	WE-S2/F4	FPS	PSI
0.277E 00	0.347200E 01	0.500000E-03	0.149000E 02	0.318000E-02
0.500E-03	0.437093E 00	0.236991E-02	0.647999E 03	0.337929E 01
0.100E-02	0.865309E 00	0.242861E-02	0.621861E 03	0.317711E 01
0.150E-02	0.128414E 01	0.248602E-02	0.596389E 03	0.298021E 01
0.200E-02	0.169313E 01	0.254208E-02	0.571568E 03	0.278906E 01
0.250E-02	0.209186E 01	0.259673E-02	0.547385E 03	0.260405E 01
0.300E-02	0.247996E 01	0.264993E-02	0.523823E 03	0.242549E 01
0.350E-02	0.285708E 01	0.270162E-02	0.500865E 03	0.225360E 01
0.400E-02	0.322292E 01	0.275176E-02	0.478494E 03	0.208856E 01
0.450E-02	0.357722E 01	0.280033E-02	0.456691E 03	0.193048E 01
0.500E-02	0.391973E 01	0.284727E-02	0.435436E 03	0.177940E 01
0.550E-02	0.425024E 01	0.289258E-02	0.414709E 03	0.163535E 01
0.600E-02	0.456857E 01	0.293621E-02	0.394489E 03	0.149829E 01
0.650E-02	0.487457E 01	0.297815E-02	0.374757E 03	0.136817E 01
0.700E-02	0.516808E 01	0.301838E-02	0.355490E 03	0.124489E 01
0.750E-02	0.544899E 01	0.305689E-02	0.336667E 03	0.112836E 01
0.800E-02	0.571720E 01	0.309365E-02	0.318267E 03	0.101846E 01
0.850E-02	0.597262E 01	0.312866E-02	0.300266E 03	0.915027E 00
0.900E-02	0.621517E 01	0.316191E-02	0.282643E 03	0.817932E 00
0.950E-02	0.644479E 01	0.319338E-02	0.265375E 03	0.727017E 00
0.100E-01	0.666142E 01	0.322307E-02	0.248439E 03	0.642124E 00
0.105E-01	0.686502E 01	0.325098E-02	0.231811E 03	0.563095E 00
0.110E-01	0.705554E 01	0.327710E-02	0.215469E 03	0.489775E 00
0.115E-01	0.723294E 01	0.330141E-02	0.199386E 03	0.422009E 00
0.120E-01	0.739718E 01	0.332392E-02	0.183539E 03	0.359653E 00
0.125E-01	0.754822E 01	0.334463E-02	0.167899E 03	0.302565E 00
0.130E-01	0.768860E 01	0.336351E-02	0.152439E 03	0.250615E 00
0.135E-01	0.781051E 01	0.338058E-02	0.137126E 03	0.203683E 00
0.140E-01	0.792164E 01	0.339581E-02	0.121926E 03	0.161663E 00
0.145E-01	0.801932E 01	0.340920E-02	0.106795E 03	0.124462E 00
0.150E-01	0.810343E 01	0.342073E-02	0.916798E 02	0.920039E-01
0.155E-01	0.817381E 01	0.343038E-02	0.765054E 02	0.642361E-01
0.160E-01	0.823018E 01	0.343810E-02	0.611536E 02	0.411327E-01
0.165E-01	0.827211E 01	0.344385E-02	0.454004E 02	0.227101E-01
0.170E-01	0.829860E 01	0.344748E-02	0.286548E 02	0.905852E-02
0.175E-01	0.830453E 01	0.344829E-02	0.640337E 01	0.452723E-03
0.180E-01	0.829427E 01	0.344677E-02	0.110816E 02	0.147014E-02
0.185E-01	0.830628E 01	0.344841E-02	0.129733E 02	0.185806E-02
0.190E-01	0.829420E 01	0.344662E-02	0.130459E 02	0.203748E-02
0.195E-01	0.830628E 01	0.344828E-02	0.130527E 02	0.188087E-02
0.200E-01	0.829420E 01	0.344648E-02	0.130495E 02	0.203851E-02
0.205E-01	0.830628E 01	0.344814E-02	0.130528E 02	0.188091E-02
0.210E-01	0.829420E 01	0.344634E-02	0.130498E 02	0.203851E-02
0.215E-01	0.830628E 01	0.344800E-02	0.130531E 02	0.188099E-02
0.220E-01	0.829420E 01	0.344620E-02	0.130500E 02	0.203852E-02
0.225E-01	0.830628E 01	0.344786E-02	0.130534E 02	0.188107E-02

Table B-VI. Fill Time Prediction - 20% Open, 3.6 psi - Rear Room

AREA1	VOLUME	TIME	PRESSURE	DENSITY
TIME	PRESSURE	DENS	U2	DPT
SECONDS	PSI	UE-S2/F4	FPS	PSI
0.277E 00	0.578700E 01	0.100000E-02	0.149000E 02	0.318000E-02
0.100E-02	0.524482E 00	0.238189E-02	0.647999E 03	0.337929E 01
0.200E-02	0.103608E 01	0.245201E-02	0.616653E 03	0.313682E 01
0.300E-02	0.153393E 01	0.252025E-02	0.586259E 03	0.290208E 01
0.400E-02	0.201725E 01	0.258650E-02	0.556794E 03	0.267585E 01
0.500E-02	0.248540E 01	0.265067E-02	0.528232E 03	0.245875E 01
0.600E-02	0.293772E 01	0.271267E-02	0.500543E 03	0.225121E 01
0.700E-02	0.337372E 01	0.277243E-02	0.473698E 03	0.205354E 01
0.800E-02	0.379292E 01	0.282989E-02	0.447663E 03	0.186593E 01
0.900E-02	0.419493E 01	0.288499E-02	0.422406E 03	0.168845E 01
0.100E-01	0.457941E 01	0.293769E-02	0.397890E 03	0.152109E 01
0.110E-01	0.494605E 01	0.298795E-02	0.374080E 03	0.136377E 01
0.120E-01	0.529465E 01	0.303573E-02	0.350939E 03	0.121635E 01
0.130E-01	0.562495E 01	0.308101E-02	0.328429E 03	0.107865E 01
0.140E-01	0.593681E 01	0.312375E-02	0.306511E 03	0.950433E 00
0.150E-01	0.623007E 01	0.316395E-02	0.285146E 03	0.831462E 00
0.160E-01	0.650461E 01	0.320158E-02	0.264295E 03	0.721474E 00
0.170E-01	0.676034E 01	0.323663E-02	0.243916E 03	0.620196E 00
0.180E-01	0.699715E 01	0.326909E-02	0.223968E 03	0.527358E 00
0.190E-01	0.721496E 01	0.329895E-02	0.204408E 03	0.442691E 00
0.200E-01	0.741369E 01	0.332619E-02	0.185190E 03	0.365939E 00
0.210E-01	0.759326E 01	0.335080E-02	0.166264E 03	0.296858E 00
0.220E-01	0.775356E 01	0.337277E-02	0.147578E 03	0.235225E 00
0.230E-01	0.789447E 01	0.339209E-02	0.129070E 03	0.180838E 00
0.240E-01	0.801583E 01	0.340872E-02	0.110664E 03	0.133529E 00
0.250E-01	0.811738E 01	0.342264E-02	0.922597E 02	0.931612E-01
0.260E-01	0.819877E 01	0.343380E-02	0.737061E 02	0.596472E-01
0.270E-01	0.825935E 01	0.344210E-02	0.547254E 02	0.329653E-01
0.280E-01	0.829774E 01	0.344736E-02	0.346064E 02	0.132069E-01
0.290E-01	0.830679E 01	0.344860E-02	0.815623E 01	0.734486E-03
0.300E-01	0.829172E 01	0.344636E-02	0.135700E 02	0.220454E-02
0.310E-01	0.830904E 01	0.344874E-02	0.155999E 02	0.268638E-02
0.320E-01	0.829165E 01	0.344615E-02	0.156564E 02	0.293449E-02
0.330E-01	0.830904E 01	0.344854E-02	0.156650E 02	0.270883E-02
0.340E-01	0.829165E 01	0.344595E-02	0.156595E 02	0.293548E-02
0.350E-01	0.830904E 01	0.344834E-02	0.156653E 02	0.270895E-02
0.360E-01	0.829165E 01	0.344575E-02	0.156600E 02	0.293549E-02
0.370E-01	0.830904E 01	0.344814E-02	0.156658E 02	0.270912E-02
0.380E-01	0.829165E 01	0.344555E-02	0.156605E 02	0.293549E-02
0.390E-01	0.830904E 01	0.344794E-02	0.156663E 02	0.270928E-02
0.400E-01	0.829165E 01	0.344535E-02	0.156609E 02	0.293550E-02

Table B-VII, Fill-Time Prediction - 20% Open, 7.5 psi - Front Room

AREA 1	VOLUME	TIME	PRESSURE	DENSITY
0.277E 00	0.347200E 01	0.500000E-03	0.149000E 02	0.410000E-02
TIME SECONDS	PRESSURE PSI	DENS UE-S2/F4	U2 FPS	DPT PSI
0.500E-03	0.634187E 00	0.239179E-02	0.882473E 03	0.628248E 01
0.100E-02	0.128824E 01	0.247531E-02	0.874755E 03	0.635963E 01
0.150E-02	0.196229E 01	0.256055E-02	0.866796E 03	0.643112E 01
0.200E-02	0.265637E 01	0.264748E-02	0.858594E 03	0.649656E 01
0.250E-02	0.336595E 01	0.273564E-02	0.846030E 03	0.649220E 01
0.300E-02	0.406734E 01	0.282278E-02	0.812954E 03	0.616656E 01
0.350E-02	0.475931E 01	0.290875E-02	0.780695E 03	0.584202E 01
0.400E-02	0.544060E 01	0.299340E-02	0.749251E 03	0.552039E 01
0.450E-02	0.611014E 01	0.307658E-02	0.718614E 03	0.520327E 01
0.500E-02	0.676689E 01	0.315818E-02	0.688778E 03	0.489203E 01
0.550E-02	0.740993E 01	0.323807E-02	0.659729E 03	0.458786E 01
0.600E-02	0.803840E 01	0.331615E-02	0.631454E 03	0.429176E 01
0.650E-02	0.865153E 01	0.339233E-02	0.603938E 03	0.400455E 01
0.700E-02	0.924863E 01	0.346651E-02	0.577162E 03	0.372690E 01
0.750E-02	0.982905E 01	0.353863E-02	0.551107E 03	0.345932E 01
0.800E-02	0.103923E 02	0.360860E-02	0.525754E 03	0.320222E 01
0.850E-02	0.109377E 02	0.367637E-02	0.501080E 03	0.295587E 01
0.900E-02	0.114650E 02	0.374189E-02	0.477061E 03	0.272045E 01
0.950E-02	0.119739E 02	0.380509E-02	0.453676E 03	0.249603E 01
0.100E-01	0.124636E 02	0.386595E-02	0.430898E 03	0.228264E 01
0.105E-01	0.129343E 02	0.392443E-02	0.408704E 03	0.208022E 01
0.110E-01	0.133854E 02	0.398048E-02	0.387067E 03	0.188866E 01
0.115E-01	0.138170E 02	0.403410E-02	0.365961E 03	0.170781E 01
0.120E-01	0.142286E 02	0.408524E-02	0.345361E 03	0.153749E 01
0.125E-01	0.146202E 02	0.413390E-02	0.325238E 03	0.137748E 01
0.130E-01	0.149917E 02	0.418005E-02	0.305566E 03	0.122754E 01
0.135E-01	0.153429E 02	0.422368E-02	0.286318E 03	0.108743E 01
0.140E-01	0.156737E 02	0.426478E-02	0.267465E 03	0.956886E 00
0.145E-01	0.159841E 02	0.430334E-02	0.248979E 03	0.835654E 00
0.150E-01	0.162739E 02	0.433935E-02	0.230831E 03	0.723472E 00
0.155E-01	0.165431E 02	0.437280E-02	0.212990E 03	0.620086E 00
0.160E-01	0.167916E 02	0.440367E-02	0.195427E 03	0.525253E 00
0.165E-01	0.170194E 02	0.443197E-02	0.178108E 03	0.438740E 00
0.170E-01	0.172264E 02	0.445769E-02	0.160997E 03	0.360330E 00
0.175E-01	0.174124E 02	0.448080E-02	0.144057E 03	0.289824E 00
0.180E-01	0.175774E 02	0.450130E-02	0.127241E 03	0.227047E 00
0.185E-01	0.177212E 02	0.451917E-02	0.110497E 03	0.171847E 00
0.190E-01	0.178436E 02	0.453437E-02	0.937538E 02	0.124104E 00
0.195E-01	0.179443E 02	0.454688E-02	0.769096E 02	0.837401E-01
0.200E-01	0.180227E 02	0.455663E-02	0.597938E 02	0.507267E-01
0.205E-01	0.180789E 02	0.456349E-02	0.420429E 02	0.251217E-01
0.210E-01	0.181075E 02	0.456716E-02	0.224152E 02	0.714937E-02
0.215E-01	0.180912E 02	0.456491E-02	0.123544E 02	0.242399E-02
0.220E-01	0.181099E 02	0.456722E-02	0.141708E 02	0.285824E-02
0.225E-01	0.180912E 02	0.456464E-02	0.141941E 02	0.319435E-02
0.230E-01	0.181098E 02	0.456696E-02	0.141996E 02	0.286985E-02

Table B-VIII, Fill-Time Prediction - 20% Open, 7.5 psi - Rear Room

AREA1	VOLUME	TIME	PRESSURE	DENSITY
0.277E 00	0.578700E 01	0.100000E-02	0.149000E 02	0.410000E-02
TIME	PRESSURE	DENS	U2	DPT
SECONDS	PSI	UE-S2/F4	FPS	PSI
0.100E-02	0.760980E 00	0.240814E-02	0.882473E 03	0.628248E 01
0.200E-02	0.155050E 01	0.250877E-02	0.873212E 03	0.637412E 01
0.300E-02	0.236874E 01	0.261185E-02	0.863605E 03	0.645756E 01
0.400E-02	0.321580E 01	0.271733E-02	0.853648E 03	0.653212E 01
0.500E-02	0.405966E 01	0.282218E-02	0.819914E 03	0.623574E 01
0.600E-02	0.489008E 01	0.292535E-02	0.781047E 03	0.584560E 01
0.700E-02	0.570500E 01	0.302660E-02	0.743346E 03	0.545953E 01
0.800E-02	0.650251E 01	0.312568E-02	0.706803E 03	0.508027E 01
0.900E-02	0.728090E 01	0.322239E-02	0.671400E 03	0.471013E 01
0.100E-01	0.803864E 01	0.331654E-02	0.637116E 03	0.435101E 01
0.110E-01	0.877435E 01	0.340794E-02	0.603927E 03	0.400444E 01
0.120E-01	0.948681E 01	0.349646E-02	0.571802E 03	0.367162E 01
0.130E-01	0.101750E 02	0.358196E-02	0.540709E 03	0.335344E 01
0.140E-01	0.108378E 02	0.366431E-02	0.510612E 03	0.305054E 01
0.150E-01	0.114746E 02	0.374343E-02	0.481471E 03	0.276332E 01
0.160E-01	0.120847E 02	0.381922E-02	0.453247E 03	0.249197E 01
0.170E-01	0.126673E 02	0.389162E-02	0.425898E 03	0.223654E 01
0.180E-01	0.132221E 02	0.396054E-02	0.399380E 03	0.199693E 01
0.190E-01	0.137486E 02	0.402596E-02	0.373647E 03	0.177295E 01
0.200E-01	0.142464E 02	0.408781E-02	0.348654E 03	0.156429E 01
0.210E-01	0.147153E 02	0.414606E-02	0.324355E 03	0.137060E 01
0.220E-01	0.151549E 02	0.420068E-02	0.300701E 03	0.119149E 01
0.230E-01	0.155652E 02	0.425165E-02	0.277643E 03	0.102652E 01
0.240E-01	0.159458E 02	0.429894E-02	0.255133E 03	0.875246E 00
0.250E-01	0.162967E 02	0.434254E-02	0.233117E 03	0.737221E 00
0.260E-01	0.166177E 02	0.438242E-02	0.211543E 03	0.612005E 00
0.270E-01	0.169087E 02	0.441857E-02	0.190353E 03	0.499178E 00
0.280E-01	0.171694E 02	0.445097E-02	0.169487E 03	0.398343E 00
0.290E-01	0.173998E 02	0.447959E-02	0.148875E 03	0.309143E 00
0.300E-01	0.175996E 02	0.450442E-02	0.128435E 03	0.231262E 00
0.310E-01	0.177685E 02	0.452539E-02	0.108063E 03	0.164439E 00
0.320E-01	0.179059E 02	0.454246E-02	0.876098E 02	0.108484E 00
0.330E-01	0.180110E 02	0.455552E-02	0.668235E 02	0.633023E-01
0.340E-01	0.180821E 02	0.456436E-02	0.451389E 02	0.289504E-01
0.350E-01	0.181140E 02	0.456832E-02	0.201852E 02	0.579816E-02
0.360E-01	0.180873E 02	0.456462E-02	0.169330E 02	0.454676E-02
0.370E-01	0.181142E 02	0.456797E-02	0.170456E 02	0.413520E-02
0.380E-01	0.180873E 02	0.456424E-02	0.170345E 02	0.460104E-02
0.390E-01	0.181142E 02	0.456759E-02	0.170410E 02	0.413298E-02
0.400E-01	0.180873E 02	0.456386E-02	0.170350E 02	0.460091E-02

Table B-IX. Fill-Time Prediction - 20% Open, 10.9 psi - Front Room

AREA1	VOLUME	TIME	PRESSURE	DENSITY
TIME SECONDS	PRESSURE PSI	DEN3 UE-S2/F4	U2 FPS	DPT PSI
0.277E 00	0.347200E 01	0.500000E-03	0.150000E 02	0.493000E-02
0.500E-03	0.706021E 00	0.239911E-02	0.963021E 03	0.746977E 01
0.100E-02	0.143825E 01	0.249054E-02	0.956166E 03	0.760974E 01
0.150E-02	0.219713E 01	0.258430E-02	0.949056E 03	0.774501E 01
0.200E-02	0.298306E 01	0.268037E-02	0.941687E 03	0.787503E 01
0.250E-02	0.379640E 01	0.277876E-02	0.934055E 03	0.799920E 01
0.300E-02	0.462748E 01	0.287945E-02	0.926157E 03	0.811696E 01
0.350E-02	0.550656E 01	0.298241E-02	0.917990E 03	0.822772E 01
0.400E-02	0.640385E 01	0.308764E-02	0.909552E 03	0.833089E 01
0.450E-02	0.732951E 01	0.319510E-02	0.900839E 03	0.842589E 01
0.500E-02	0.828362E 01	0.330475E-02	0.891850E 03	0.851216E 01
0.550E-02	0.924545E 01	0.341477E-02	0.882508E 03	0.8591730E 01
0.600E-02	0.101950E 02	0.352338E-02	0.872929E 03	0.787424E 01
0.650E-02	0.111303E 02	0.363036E-02	0.798274E 03	0.743383E 01
0.700E-02	0.120497E 02	0.373553E-02	0.764537E 03	0.699863E 01
0.750E-02	0.129516E 02	0.383870E-02	0.731710E 03	0.657084E 01
0.800E-02	0.138346E 02	0.393970E-02	0.699780E 03	0.615235E 01
0.850E-02	0.146974E 02	0.403839E-02	0.668732E 03	0.574474E 01
0.900E-02	0.155388E 02	0.413464E-02	0.638549E 03	0.534935E 01
0.950E-02	0.163577E 02	0.422831E-02	0.609211E 03	0.496723E 01
0.100E-01	0.171532E 02	0.431930E-02	0.580695E 03	0.459922E 01
0.105E-01	0.179244E 02	0.440751E-02	0.552978E 03	0.424596E 01
0.110E-01	0.186705E 02	0.449286E-02	0.526035E 03	0.390788E 01
0.115E-01	0.193910E 02	0.457526E-02	0.499838E 03	0.358528E 01
0.120E-01	0.200851E 02	0.465466E-02	0.474361E 03	0.327830E 01
0.125E-01	0.207524E 02	0.473099E-02	0.449573E 03	0.298696E 01
0.130E-01	0.213924E 02	0.480420E-02	0.425446E 03	0.271121E 01
0.135E-01	0.220048E 02	0.487425E-02	0.401949E 03	0.245087E 01
0.140E-01	0.225893E 02	0.494110E-02	0.379052E 03	0.220573E 01
0.145E-01	0.231455E 02	0.500473E-02	0.356723E 03	0.197550E 01
0.150E-01	0.236732E 02	0.506509E-02	0.334930E 03	0.175987E 01
0.155E-01	0.241723E 02	0.512218E-02	0.313641E 03	0.155848E 01
0.160E-01	0.246425E 02	0.517597E-02	0.292823E 03	0.137096E 01
0.165E-01	0.250838E 02	0.522644E-02	0.272443E 03	0.119693E 01
0.170E-01	0.254959E 02	0.527358E-02	0.252468E 03	0.103600E 01
0.175E-01	0.258789E 02	0.531738E-02	0.232861E 03	0.887800E 00
0.180E-01	0.262325E 02	0.535783E-02	0.213587E 03	0.751955E 00
0.185E-01	0.265566E 02	0.539491E-02	0.194608E 03	0.628110E 00
0.190E-01	0.268512E 02	0.542861E-02	0.175884E 03	0.515934E 00
0.195E-01	0.271162E 02	0.545891E-02	0.157369E 03	0.415120E 00
0.200E-01	0.273513E 02	0.548580E-02	0.139014E 03	0.325392E 00
0.205E-01	0.275563E 02	0.550926E-02	0.120757E 03	0.246515E 00
0.210E-01	0.277310E 02	0.552924E-02	0.102521E 03	0.178297E 00
0.215E-01	0.278748E 02	0.554569E-02	0.841950E 02	0.120603E 00
0.220E-01	0.279872E 02	0.555855E-02	0.655941E 02	0.733769E-01
0.225E-01	0.280667E 02	0.556764E-02	0.463335E 02	0.366803E-01
0.230E-01	0.281099E 02	0.557258E-02	0.251348E 02	0.106085E-01
0.235E-01	0.280877E 02	0.556972E-02	-0.128852E 02	0.321199E-02
0.240E-01	0.281139E 02	0.557271E-02	0.152450E 02	0.397758E-02

Table B-X. Fill-Time Prediction - 20% Open, 10.9 psi - Rear Room

AREA1	VOLUME	TIME	PRESSURE	DENSITY
0.277E 00	0.578700E 01	0.100000E-02	0.150000E 02	0.493000E-02
TIME	PRESSURE	DEN3	U2	DPT
SECONDS	PSI	UE-S2/F4	FPS	PSI
0.100E-02	0.647177E 00	0.241693E-02	0.963021E 03	0.746977E 01
0.200E-02	0.173201E 01	0.252719E-02	0.954795E 03	0.763659E 01
0.300E-02	0.265526E 01	0.264077E-02	0.946203E 03	0.779655E 01
0.400E-02	0.361759E 01	0.275769E-02	0.937238E 03	0.794868E 01
0.500E-02	0.461958E 01	0.287791E-02	0.927894E 03	0.809199E 01
0.600E-02	0.566171E 01	0.300141E-02	0.918164E 03	0.822548E 01
0.700E-02	0.674435E 01	0.312814E-02	0.908045E 03	0.834814E 01
0.800E-02	0.786774E 01	0.325806E-02	0.897532E 03	0.845898E 01
0.900E-02	0.902751E 01	0.339073E-02	0.884053E 03	0.850747E 01
0.100E-01	0.101704E 02	0.352146E-02	0.840947E 03	0.797496E 01
0.110E-01	0.112932E 02	0.364988E-02	0.799164E 03	0.744524E 01
0.120E-01	0.123929E 02	0.377567E-02	0.758697E 03	0.692279E 01
0.130E-01	0.134667E 02	0.389851E-02	0.719531E 03	0.641141E 01
0.140E-01	0.145124E 02	0.401611E-02	0.681645E 03	0.591425E 01
0.150E-01	0.155277E 02	0.413425E-02	0.645012E 03	0.543387E 01
0.160E-01	0.165107E 02	0.424669E-02	0.609599E 03	0.497226E 01
0.170E-01	0.174597E 02	0.435525E-02	0.575369E 03	0.453096E 01
0.180E-01	0.183734E 02	0.445976E-02	0.542281E 03	0.411103E 01
0.190E-01	0.192504E 02	0.456007E-02	0.510290E 03	0.371320E 01
0.200E-01	0.200895E 02	0.465606E-02	0.479351E 03	0.333785E 01
0.210E-01	0.208900E 02	0.474762E-02	0.449413E 03	0.298510E 01
0.220E-01	0.216511E 02	0.483467E-02	0.420424E 03	0.265486E 01
0.230E-01	0.223720E 02	0.491714E-02	0.392334E 03	0.234686E 01
0.240E-01	0.230522E 02	0.499495E-02	0.365086E 03	0.206067E 01
0.250E-01	0.236914E 02	0.506805E-02	0.338626E 03	0.179579E 01
0.260E-01	0.242890E 02	0.513641E-02	0.312898E 03	0.155162E 01
0.270E-01	0.248448E 02	0.519999E-02	0.287843E 03	0.132753E 01
0.280E-01	0.253586E 02	0.525876E-02	0.263401E 03	0.112287E 01
0.290E-01	0.258300E 02	0.531268E-02	0.239512E 03	0.936965E 00
0.300E-01	0.262590E 02	0.536175E-02	0.216111E 03	0.769176E 00
0.310E-01	0.266452E 02	0.540592E-02	0.193129E 03	0.618884E 00
0.320E-01	0.269884E 02	0.544518E-02	0.170491E 03	0.485519E 00
0.330E-01	0.272883E 02	0.547949E-02	0.148109E 03	0.368565E 00
0.340E-01	0.275445E 02	0.550879E-02	0.125878E 03	0.267582E 00
0.350E-01	0.277563E 02	0.553302E-02	0.103654E 03	0.182222E 00
0.360E-01	0.279229E 02	0.555208E-02	0.812136E 02	0.112261E 00
0.370E-01	0.280425E 02	0.556575E-02	0.581203E 02	0.576545E-01
0.380E-01	0.281106E 02	0.557355E-02	0.330554E 02	0.186863E-01
0.390E-01	0.280831E 02	0.556999E-02	-0.133330E 02	0.343969E-02
0.400E-01	0.281200E 02	0.557422E-02	0.179073E 02	0.548774E-02

APPENDIX C

TABLES OF PREDICTED FILL PARAMETERS FOR FULL SIZE SHELTERS

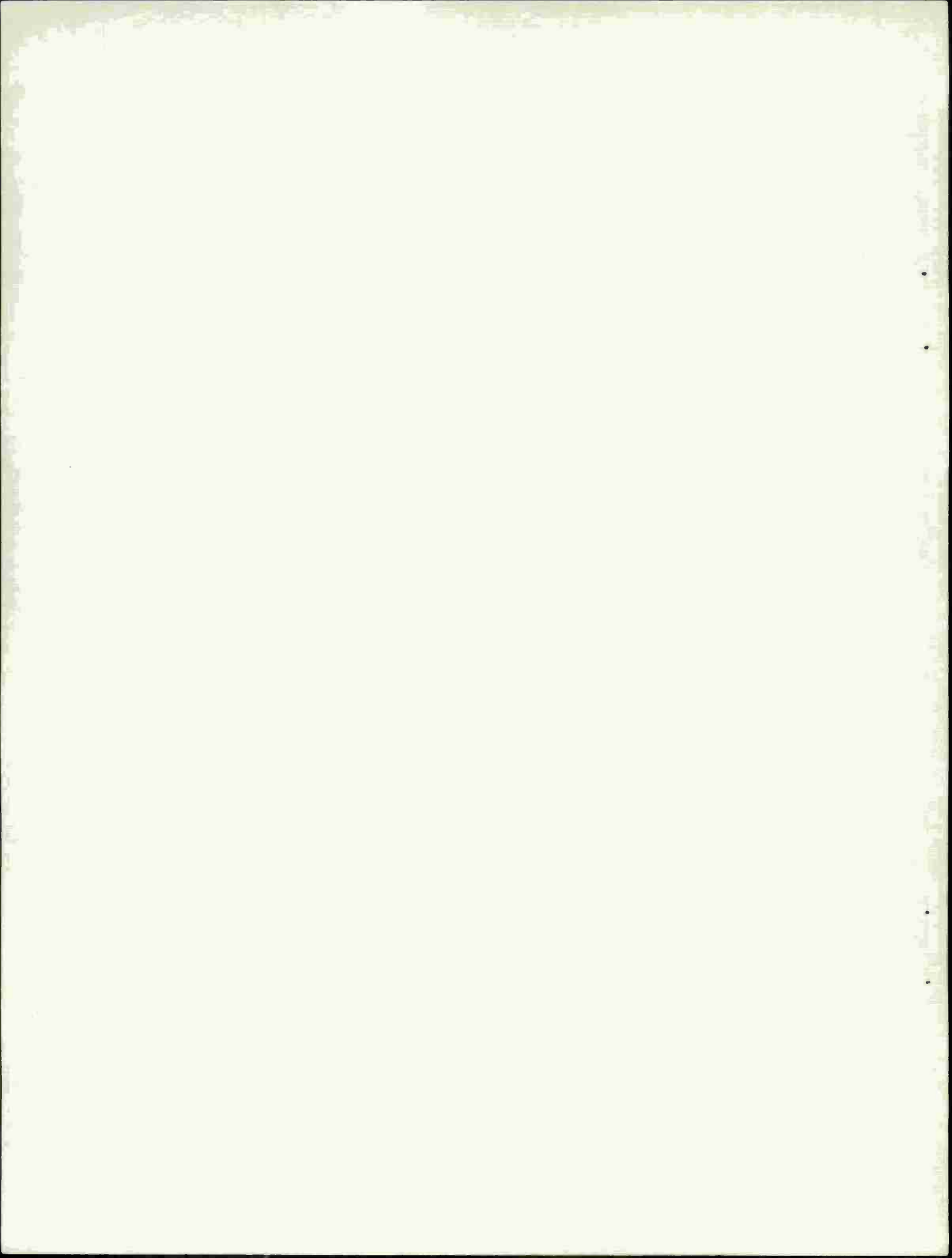


Table C-I. Fill-Time Prediction - 49% Open, 3 psi - Front Room

AREA1 0.975E 02	VOLUME 0.600000E 04	TIME 0.100000E+01	PRESSURE 0.147000E 02	DENSITY 0.302000E-02
TIME SECONDS	PRESSURE PSI	DEN3 UE-52/F4	U2 FPS	DPT PSI
0.100E-01	0.149795E 01	0.254347E+02	0.565007E 03	0.257714E 01
0.200E-01	0.282373E 01	0.273254E+02	0.466921E 03	0.189633E 01
0.300E-01	0.395685E 01	0.289425E+02	0.377537E 03	0.130453E 01
0.400E-01	0.488304E 01	0.302652E+02	0.295297E 03	0.834626E 00
0.500E-01	0.559041E 01	0.312762E+02	0.218017E 03	0.470960E 00
0.600E-01	0.606269E 01	0.319516E+02	0.142015E 03	0.204965E 00
0.700E-01	0.624510E 01	0.322127E+02	0.539978E 02	0.301231E-01
0.800E-01	0.602737E 01	0.318779E+02	-0.642795E 02	0.459923E-01
0.900E-01	0.612427E 01	0.320167E+02	0.287579E 02	0.853362E-02
0.100E 00	0.592342E 01	0.317079E+02	-0.596022E 02	0.393285E-01
0.110E 00	0.602790E 01	0.318579E+02	0.311646E 02	0.998583E-02
0.120E 00	0.582572E 01	0.315471E+02	-0.602817E 02	0.400270E-01
0.130E 00	0.593019E 01	0.316973E+02	0.313096E 02	0.100448E-01
0.140E 00	0.572940E 01	0.313888E+02	-0.501478E 02	0.396493E-01
0.150E 00	0.583475E 01	0.315404E+02	0.317198E 02	0.102752E-01
0.160E 00	0.563503E 01	0.312336E+02	-0.601056E 02	0.393979E-01
0.170E 00	0.574109E 01	0.313864E+02	0.320831E 02	0.104772E-01
0.180E 00	0.554246E 01	0.310815E+02	-0.600498E 02	0.391332E-01
0.190E 00	0.564921E 01	0.312355E+02	0.324369E 02	0.106747E-01
0.200E 00	0.545166E 01	0.309322E+02	-0.599930E 02	0.388718E-01
0.210E 00	0.555905E 01	0.310874E+02	0.327777E 02	0.109653E-01
0.220E 00	0.536256E 01	0.307859E+02	-0.599340E 02	0.366118E-01
0.230E 00	0.547055E 01	0.309421E+02	0.331070E 02	0.110496E-01
0.240E 00	0.527512E 01	0.306423E+02	-0.598734E 02	0.383540E-01
0.250E 00	0.538367E 01	0.307995E+02	0.334248E 02	0.112277E-01
0.260E 00	0.518928E 01	0.305014E+02	-0.598111E 02	0.380982E-01
0.270E 00	0.529836E 01	0.306595E+02	0.337310E 02	0.113992E-01
0.280E 00	0.510500E 01	0.303631E+02	-0.597473E 02	0.378446E-01
0.290E 00	0.521456E 01	0.305222E+02	0.340267E 02	0.115648E-01
0.300E 00	0.502222E 01	0.302274E+02	-0.596822E 02	0.375933E-01
0.310E 00	0.513225E 01	0.303873E+02	0.343124E 02	0.117247E-01
0.320E 00	0.494092E 01	0.300941E+02	-0.596158E 02	0.373444E-01
0.330E 00	0.505137E 01	0.302549E+02	0.345884E 02	0.118790E-01
0.340E 00	0.486103E 01	0.299633E+02	-0.595490E 02	0.370987E-01
0.350E 00	0.497188E 01	0.301248E+02	0.348551E 02	0.120278E-01
0.360E 00	0.478252E 01	0.298348E+02	-0.594814E 02	0.368558E-01
0.370E 00	0.489374E 01	0.299970E+02	0.351129E 02	0.121714E-01
0.380E 00	0.470535E 01	0.297086E+02	-0.594133E 02	0.366159E-01
0.390E 00	0.481692E 01	0.298715E+02	0.353628E 02	0.123103E-01
0.400E 00	0.462948E 01	0.295846E+02	-0.593449E 02	0.363791E-01
0.410E 00	0.474137E 01	0.297482E+02	0.356038E 02	0.124438E-01
0.420E 00	0.455487E 01	0.294628E+02	-0.592759E 02	0.361451E-01
0.430E 00	0.466707E 01	0.296270E+02	0.358369E 02	0.125725E-01
0.440E 00	0.448149E 01	0.293431E+02	-0.592066E 02	0.359142E-01

Table C-II. Fill-Time Prediction - 49% Open, 3 psi - Both Rooms

AREA1	VOLUME	TIME	PRESSURE	DENSITY
0.975E 02	0.100000E 05	0.100000E+01	0.147000E 02	0.302000E-02
TIME	PRESSURE	DENS3	U2	DPT
SECONDS	PSI	UE-S2/F4	FPS	PSI
0.100E+01	0.898773E 00	0.245808E+02	0.565007E 03	0.257714E 01
0.200E+01	0.173655E 01	0.257755E+02	0.505173E 03	0.214941E 01
0.300E+01	0.250852E 01	0.268773E+02	0.448749E 03	0.176066E 01
0.400E+01	0.321096E 01	0.278805E+02	0.395446E 03	0.141280E 01
0.500E+01	0.384096E 01	0.287809E+02	0.344920E 03	0.110599E 01
0.600E+01	0.439618E 01	0.295749E+02	0.296774E 03	0.839250E 00
0.700E+01	0.487454E 01	0.302596E+02	0.250536E 03	0.610851E 00
0.800E+01	0.527385E 01	0.308315E+02	0.205616E 03	0.418777E 00
0.900E+01	0.559118E 01	0.312863E+02	0.161174E 03	0.261050E 00
0.100E 00	0.582144E 01	0.316165E+02	0.115719E 03	0.135091E 00
0.110E 00	0.595175E 01	0.318035E+02	0.650062E 02	0.432945E-01
0.120E 00	0.587724E 01	0.316888E+02	-0.370656E 02	0.151469E-01
0.130E 00	0.582779E 01	0.316126E+02	-0.246646E 02	0.668885E-02
0.140E 00	0.578012E 01	0.315392E+02	-0.238331E 02	0.623073E-02
0.150E 00	0.573263E 01	0.314661E+02	-0.237974E 02	0.619768E-02
0.160E 00	0.568568E 01	0.313938E+02	-0.235843E 02	0.607312E-02
0.170E 00	0.563916E 01	0.313221E+02	-0.234180E 02	0.597406E-02
0.180E 00	0.559310E 01	0.312512E+02	-0.232417E 02	0.587110E-02
0.190E 00	0.554748E 01	0.311810E+02	-0.230725E 02	0.577288E-02
0.200E 00	0.550229E 01	0.311114E+02	-0.229027E 02	0.567549E-02
0.210E 00	0.545753E 01	0.310424E+02	-0.227374E 02	0.558143E-02
0.220E 00	0.541320E 01	0.309742E+02	-0.225722E 02	0.548846E-02
0.230E 00	0.536928E 01	0.309065E+02	-0.224105E 02	0.539826E-02
0.240E 00	0.532576E 01	0.308395E+02	-0.222504E 02	0.530983E-02
0.250E 00	0.528265E 01	0.307731E+02	-0.220916E 02	0.522312E-02
0.260E 00	0.523994E 01	0.307073E+02	-0.219370E 02	0.513912E-02
0.270E 00	0.519761E 01	0.306422E+02	-0.217822E 02	0.505603E-02
0.280E 00	0.515567E 01	0.305776E+02	-0.216315E 02	0.497577E-02
0.290E 00	0.511411E 01	0.305136E+02	-0.214805E 02	0.489627E-02
0.300E 00	0.507292E 01	0.304501E+02	-0.213334E 02	0.481933E-02
0.310E 00	0.503209E 01	0.303873E+02	-0.211868E 02	0.474348E-02
0.320E 00	0.499163E 01	0.303250E+02	-0.210422E 02	0.466932E-02
0.330E 00	0.495152E 01	0.302632E+02	-0.209003E 02	0.459738E-02
0.340E 00	0.491177E 01	0.302020E+02	-0.207553E 02	0.452612E-02
0.350E 00	0.487236E 01	0.301413E+02	-0.206217E 02	0.445734E-02
0.360E 00	0.483329E 01	0.300811E+02	-0.204836E 02	0.439004E-02
0.370E 00	0.479455E 01	0.300215E+02	-0.203495E 02	0.432313E-02
0.380E 00	0.475615E 01	0.299623E+02	-0.202150E 02	0.425774E-02
0.390E 00	0.471807E 01	0.299037E+02	-0.200830E 02	0.419406E-02
0.400E 00	0.468031E 01	0.298455E+02	-0.199537E 02	0.413213E-02
0.410E 00	0.464287E 01	0.297879E+02	-0.198241E 02	0.407074E-02
0.420E 00	0.460573E 01	0.297307E+02	-0.196984E 02	0.401153E-02

Table C-III. Fill-Time Prediction - 49% Open, 7 psi - Front Room

AREA1 0.975E 02	VOLUME 0.600000E 04	TIME 0.100000E+01	PRESSURE 0.147000E 02	DENSITY 0.398000E-02
TIME SECONDS	PRESSURE PSI	DEN3 UE-S2/F4	U2 FPS	DPT PSI
0.100E+01	0.249691E 01	0.265577E+02	0.866177E 03	0.602930E 01
0.200E+01	0.516358E 01	0.299461E+02	0.805451E 03	0.583174E 01
0.300E+01	0.762962E 01	0.330848E+02	0.573076E 03	0.451406E 01
0.400E+01	0.982794E 01	0.358873E+02	0.552790E 03	0.331026E 01
0.500E+01	0.117116E 02	0.382926E+02	0.443648E 03	0.228007E 01
0.600E+01	0.132481E 02	0.402577E+02	0.343816E 03	0.144369E 01
0.700E+01	0.144113E 02	0.417478E+02	0.250388E 03	0.797241E 00
0.800E+01	0.151655E 02	0.427155E+02	0.157929E 03	0.326540E 00
0.900E+01	0.153517E 02	0.429547E+02	0.383404E 02	0.195002E-01
0.100E 00	0.149645E 02	0.424013E+02	-0.798401E 02	0.944206E-01
0.110E 00	0.147861E 02	0.421463E+02	-0.370677E 02	0.201988E-01
0.120E 00	0.146392E 02	0.419363E+02	-0.306893E 02	0.137687E-01
0.130E 00	0.144766E 02	0.417040E+02	-0.341315E 02	0.169416E-01
0.140E 00	0.143272E 02	0.414904E+02	-0.315467E 02	0.143953E-01
0.150E 00	0.141727E 02	0.412695E+02	-0.328083E 02	0.154686E-01
0.160E 00	0.140246E 02	0.410578E+02	-0.315929E 02	0.142871E-01
0.170E 00	0.138753E 02	0.408444E+02	-0.320243E 02	0.146042E-01
0.180E 00	0.137299E 02	0.406366E+02	-0.313523E 02	0.139256E-01
0.190E 00	0.135848E 02	0.404292E+02	-0.314411E 02	0.139332E-01
0.200E 00	0.134424E 02	0.402256E+02	-0.310109E 02	0.134858E-01
0.210E 00	0.133010E 02	0.400235E+02	-0.309496E 02	0.133649E-01
0.220E 00	0.131618E 02	0.398245E+02	-0.306298E 02	0.130246E-01
0.230E 00	0.130238E 02	0.396273E+02	-0.305070E 02	0.128563E-01
0.240E 00	0.128877E 02	0.394328E+02	-0.302402E 02	0.125701E-01
0.250E 00	0.127529E 02	0.392402E+02	-0.300897E 02	0.123843E-01
0.260E 00	0.126199E 02	0.390500E+02	-0.298561E 02	0.121333E-01
0.270E 00	0.124882E 02	0.388617E+02	-0.296903E 02	0.119410E-01
0.280E 00	0.123581E 02	0.386758E+02	-0.294790E 02	0.117151E-01
0.290E 00	0.122298E 02	0.384917E+02	-0.293085E 02	0.115246E-01
0.300E 00	0.121020E 02	0.383098E+02	-0.291087E 02	0.113141E-01
0.310E 00	0.119761E 02	0.381298E+02	-0.289417E 02	0.111319E-01
0.320E 00	0.118516E 02	0.379518E+02	-0.287497E 02	0.109332E-01
0.330E 00	0.117284E 02	0.377757E+02	-0.285835E 02	0.107568E-01
0.340E 00	0.116065E 02	0.376015E+02	-0.284041E 02	0.105731E-01
0.350E 00	0.114859E 02	0.374291E+02	-0.282374E 02	0.104012E-01
0.360E 00	0.113666E 02	0.372586E+02	-0.280647E 02	0.102274E-01
0.370E 00	0.112485E 02	0.370898E+02	-0.279056E 02	0.100658E-01
0.380E 00	0.111316E 02	0.369227E+02	-0.277355E 02	0.989846E-02
0.390E 00	0.110159E 02	0.367574E+02	-0.275813E 02	0.974473E-02
0.400E 00	0.109015E 02	0.365938E+02	-0.274188E 02	0.958719E-02

Table C-IV. Fill-Time Prediction - 49% Open, 7 psi - Both Rooms

AREA1	VOLUME	TIME	PRESSURE	DENSITY
TIME	PRESSURE	DEN3	U2	DPT
SECONDS	PSI	UE-S2/F4	FPS	PSI
0.975E 02	0.10000E 05	0.10000E+01	0.14700E 02	0.39800E-02
0.100E+01	0.149814E 01	0.252546E+02	0.856177E 03	0.602930E 01
0.200E+01	0.310112E 01	0.272989E+02	0.845264E 03	0.615380E 01
0.300E+01	0.466779E 01	0.292929E+02	0.770724E 03	0.547305E 01
0.400E+01	0.615616E 01	0.311904E+02	0.690515E 03	0.465600E 01
0.500E+01	0.755140E 01	0.329720E+02	0.614958E 03	0.390172E 01
0.600E+01	0.884164E 01	0.346221E+02	0.543853E 03	0.319607E 01
0.700E+01	0.100176E 02	0.361286E+02	0.476888E 03	0.255842E 01
0.800E+01	0.110721E 02	0.374815E+02	0.413643E 03	0.199302E 01
0.900E+01	0.119994E 02	0.386731E+02	0.353590E 03	0.150044E 01
0.100E 00	0.127944E 02	0.396963E+02	0.296054E 03	0.107877E 01
0.110E 00	0.134518E 02	0.405438E+02	0.240129E 03	0.724731E 00
0.120E 00	0.139645E 02	0.412057E+02	0.184408E 03	0.434687E 00
0.130E 00	0.143189E 02	0.416638E+02	0.126019E 03	0.205631E 00
0.140E 00	0.144695E 02	0.418589E+02	0.531784E 02	0.369400E-01
0.150E 00	0.142842E 02	0.415931E+02	-0.654441E 02	0.619599E-01
0.160E 00	0.141171E 02	0.413533E+02	-0.593609E 02	0.506944E-01
0.170E 00	0.139605E 02	0.411285E+02	-0.559423E 02	0.447831E-01
0.180E 00	0.138097E 02	0.409121E+02	-0.541271E 02	0.417051E-01
0.190E 00	0.136625E 02	0.407008E+02	-0.531243E 02	0.399675E-01
0.200E 00	0.135178E 02	0.404932E+02	-0.524942E 02	0.389263E-01
0.210E 00	0.133751E 02	0.402884E+02	-0.520231E 02	0.379400E-01

Table C-V. Fill-Time Prediction - 49% Open, 10 psi - Front Room

AREA1 0.975E 02	VOLUME 0.600000E 04	TIME 0.100000E+01	PRESSURE 0.147000E 02	DENSITY 0.471000E-02
TIME SECONDS	PRESSURE PSI	DEN3 UE-S2/F4	U2 FPS	DPT PSI
0.100E-01	0.274285E 01	0.268195E+02	0.940010E 03	0.705908E 01
0.200E-01	0.586236E 01	0.306660E+02	0.909200E 03	0.747286E 01
0.300E-01	0.936816E 01	0.348252E+02	0.874071E 03	0.775786E 01
0.400E-01	0.126546E 02	0.387252E+02	0.732442E 03	0.610367E 01
0.500E-01	0.155892E 02	0.422151E+02	0.598162E 03	0.445055E 01
0.600E-01	0.180983E 02	0.452055E+02	0.476574E 03	0.304525E 01
0.700E-01	0.201315E 02	0.476340E+02	0.355627E 03	0.189726E 01
0.800E-01	0.216480E 02	0.494492E+02	0.261749E 03	0.101542E 01
0.900E-01	0.225885E 02	0.505774E+02	0.157838E 03	0.380495E 00
0.100E 00	0.223672E 02	0.502772E+02	-0.365610E 02	0.234679E-01
0.110E 00	0.220806E 02	0.498884E+02	-0.476426E 02	0.395149E-01
0.120E 00	0.218190E 02	0.495337E+02	-0.438491E 02	0.332388E-01
0.130E 00	0.215562E 02	0.491772E+02	-0.443750E 02	0.337980E-01
0.140E 00	0.212985E 02	0.488276E+02	-0.438388E 02	0.327512E-01
0.150E 00	0.210439E 02	0.484823E+02	-0.436056E 02	0.321738E-01
0.160E 00	0.207929E 02	0.481418E+02	-0.432926E 02	0.314902E-01
0.170E 00	0.205453E 02	0.478060E+02	-0.430078E 02	0.308599E-01
0.180E 00	0.203011E 02	0.474748E+02	-0.427233E 02	0.302413E-01
0.190E 00	0.200601E 02	0.471479E+02	-0.424474E 02	0.296458E-01
0.200E 00	0.198223E 02	0.468254E+02	-0.421733E 02	0.290634E-01
0.210E 00	0.195877E 02	0.465071E+02	-0.419039E 02	0.284977E-01
0.220E 00	0.193561E 02	0.461930E+02	-0.416418E 02	0.279516E-01
0.230E 00	0.191275E 02	0.458829E+02	-0.413850E 02	0.274220E-01

Table C-VI. Fill-Time Prediction - 49% Open, 10 psi - Both Rooms

AREA 1	VOLUME	TIME	PRESSURE	DENSITY
0.975E 02	0.100000E 05	0.100000E+01	0.147000E 02	0.471000E-02
TIME	PRESSURE	DEN 3	U2	DPT
SECONDS	PSI	UE-52/F4	FPS	PSI
0.100E+01	0.164571E 01	0.254117E+02	0.940010E 03	0.705908E 01
0.200E+01	0.342752E 01	0.276427E+02	0.920626E 03	0.731451E 01
0.300E+01	0.534377E 01	0.299899E+02	0.899602E 03	0.751493E 01
0.400E+01	0.740693E 01	0.324485E+02	0.876880E 03	0.767762E 01
0.500E+01	0.943408E 01	0.348593E+02	0.850184E 03	0.688426E 01
0.600E+01	0.113518E 02	0.371449E+02	0.714025E 03	0.561192E 01
0.700E+01	0.131389E 02	0.392795E+02	0.631397E 03	0.479974E 01
0.800E+01	0.147788E 02	0.412423E+02	0.553717E 03	0.387052E 01
0.900E+01	0.162583E 02	0.430170E+02	0.480587E 03	0.303734E 01
0.100E 00	0.175673E 02	0.445905E+02	0.411460E 03	0.230566E 01
0.110E 00	0.186975E 02	0.459518E+02	0.345610E 03	0.167556E 01
0.120E 00	0.196409E 02	0.470905E+02	0.282052E 03	0.114374E 01
0.130E 00	0.203875E 02	0.479936E+02	0.219288E 03	0.705240E 00
0.140E 00	0.209204E 02	0.486394E+02	0.154434E 03	0.355197E 00
0.150E 00	0.211913E 02	0.489684E+02	0.778196E 02	0.911663E-01
0.160E 00	0.209523E 02	0.486423E+02	-0.586293E 02	0.796938E-01
0.170E 00	0.207092E 02	0.483107E+02	-0.702788E 02	0.829947E-01
0.180E 00	0.204657E 02	0.479785E+02	-0.708900E 02	0.838613E-01
0.190E 00	0.202236E 02	0.476482E+02	-0.709879E 02	0.835138E-01
0.200E 00	0.199837E 02	0.473209E+02	-0.708214E 02	0.825522E-01
0.210E 00	0.197465E 02	0.469972E+02	-0.705180E 02	0.812877E-01
0.220E 00	0.195121E 02	0.466774E+02	-0.701468E 02	0.798883E-01
0.230E 00	0.192806E 02	0.463616E+02	-0.697441E 02	0.784408E-01
0.240E 00	0.190521E 02	0.460497E+02	-0.593270E 02	0.769856E-01
0.250E 00	0.188264E 02	0.457419E+02	-0.589056E 02	0.755456E-01
0.260E 00	0.186036E 02	0.454379E+02	-0.584872E 02	0.741363E-01
0.270E 00	0.183836E 02	0.451378E+02	-0.580746E 02	0.727631E-01
0.280E 00	0.181664E 02	0.448414E+02	-0.576670E 02	0.714236E-01
0.290E 00	0.179519E 02	0.445487E+02	-0.572654E 02	0.701188E-01
0.300E 00	0.177399E 02	0.442596E+02	-0.568721E 02	0.688527E-01
0.310E 00	0.175306E 02	0.439740E+02	-0.564889E 02	0.675236E-01
0.320E 00	0.173238E 02	0.436918E+02	-0.561075E 02	0.664261E-01
0.330E 00	0.171195E 02	0.434130E+02	-0.557344E 02	0.652603E-01
0.340E 00	0.169176E 02	0.431376E+02	-0.553697E 02	0.641296E-01
0.350E 00	0.167180E 02	0.428653E+02	-0.550125E 02	0.630310E-01
0.360E 00	0.165208E 02	0.425962E+02	-0.546605E 02	0.619599E-01
0.370E 00	0.163259E 02	0.423303E+02	-0.543147E 02	0.609169E-01
0.380E 00	0.161332E 02	0.420674E+02	-0.539767E 02	0.599045E-01
0.390E 00	0.159426E 02	0.418074E+02	-0.536452E 02	0.589197E-01
0.400E 00	0.157543E 02	0.415504E+02	-0.533186E 02	0.579588E-01

Table C-VII, Fill-Time Prediction - 20% Open, 3 psi - Front Room

AREA1 0.400E 02	VOLUME 0.600000E 04	TIME 0.100000E+01	PRESSURE 0.147000F 02	DENSITY 0.302000E-02
TIME SECONDS	PRESSURE PSI	DFN3 UF-52/F4	U2 FPS	UPT PSI
0.100E+01	0.614545E 00	0.241758E+02	0.565007F 03	0.257714F 01
0.200E+01	0.120016F 01	0.250109E+02	0.523266F 03	0.227604E 01
0.300E+01	0.175521E 01	0.258030E+02	0.483193E 03	0.199351E 01
0.400E+01	0.227833F 01	0.265501E+02	0.444696E 03	0.173040E 01
0.500E+01	0.276839F 01	0.272505E+02	0.407672F 03	0.149713E 01
0.600E+01	0.322443F 01	0.279028E+02	0.372005E 03	0.125373E 01
0.700E+01	0.364565E 01	0.285056E+02	0.337571F 03	0.105994E 01
0.800E+01	0.403135E 01	0.290580F+02	0.304228E 03	0.875295E 00
0.900E+01	0.438088E 01	0.295590E+02	0.271820E 03	0.709206E 00
0.100E 00	0.469359E 01	0.300075E+02	0.240163E 03	0.560995E 00
0.110E 00	0.496876E 01	0.304024E+02	0.209038E 03	0.429969F 00
0.120E 00	0.520549E 01	0.307424E+02	0.178156E 03	0.315471F 00
0.130E 00	0.540251E 01	0.310255E+02	0.147106E 03	0.216936E 00
0.140E 00	0.555778E 01	0.312488E+02	0.115198E 03	0.133972E 00
0.150E 00	0.566740E 01	0.314066E+02	0.809306E 02	0.665019F-01
0.160E 00	0.571975E 01	0.314819E+02	0.385238F 02	0.151232E-01
0.170E 00	0.566602E 01	0.313991E+02	-0.395424F 02	0.170607F-01
0.180E 00	0.561636E 01	0.313225F+02	-0.366321E 02	0.146071F-01
0.190E 00	0.556896E 01	0.312495E+02	-0.350441E 02	0.133372E-01
0.200E 00	0.552283F 01	0.311783F+02	-0.341845E 02	0.125623E-01
0.210E 00	0.547749E 01	0.311084E+02	-0.336760F 02	0.122609E-01
0.220E 00	0.543273E 01	0.310394E+02	-0.333227E 02	0.119784F-01
0.230E 00	0.538844E 01	0.309711E+02	-0.330371E 02	0.117481E-01
0.240E 00	0.534460E 01	0.309035E+02	-0.327809E 02	0.115414F-01

Table C-VIII. Fill-Time Prediction - 20% Open, 3 psi - Both Rooms

AREA1 0.400E 02	VOLUME 0.100000E 05	TIME 0.100000E+01	PRESSURE 0.147000E 02	DENSITY 0.302000E-02
TIME SECONDS	PRESSURE PSI	DEN3 UE-S2/F4	U2 FPS	DPT PSI
0.100E+01	0.368727E 00	0.238255E+02	0.565007E 03	0.257714E 01
0.200E+01	0.726440E 00	0.243356E+02	0.538911E 03	0.238643E 01
0.300E+01	0.107276E 01	0.248298E+02	0.513452E 03	0.220289E 01
0.400E+01	0.140735E 01	0.253077E+02	0.488612E 03	0.202679E 01
0.500E+01	0.172992E 01	0.257687E+02	0.464366E 03	0.185828E 01
0.600E+01	0.204018E 01	0.262124E+02	0.440690E 03	0.169750E 01
0.700E+01	0.233790E 01	0.266385E+02	0.417558E 03	0.154447E 01
0.800E+01	0.262286E 01	0.270467E+02	0.394942E 03	0.139921E 01
0.900E+01	0.289488E 01	0.274365E+02	0.372812E 03	0.126165E 01
0.100E 00	0.315377E 01	0.278078E+02	0.351136E 03	0.113173E 01
0.110E 00	0.339936E 01	0.281603E+02	0.329879E 03	0.100933E 01
0.120E 00	0.363152E 01	0.284937E+02	0.309005E 03	0.894322E 00
0.130E 00	0.385008E 01	0.288078E+02	0.288472E 03	0.786547E 00
0.140E 00	0.405490E 01	0.291024E+02	0.268236E 03	0.685847E 00
0.150E 00	0.424583E 01	0.293771E+02	0.248246E 03	0.592058E 00
0.160E 00	0.442268E 01	0.296318E+02	0.228444E 03	0.505012E 00
0.170E 00	0.458527E 01	0.298661E+02	0.208762E 03	0.424546E 00
0.180E 00	0.473335E 01	0.300796E+02	0.189115E 03	0.350510E 00
0.190E 00	0.486663E 01	0.302719E+02	0.169396E 03	0.282767E 00
0.200E 00	0.498473E 01	0.304424E+02	0.149462E 03	0.221209E 00
0.210E 00	0.508712E 01	0.305903E+02	0.129104E 03	0.165763E 00
0.220E 00	0.517302E 01	0.307145E+02	0.107990E 03	0.116409E 00
0.230E 00	0.524122E 01	0.308131E+02	0.855113E 02	0.732167E-01
0.240E 00	0.528934E 01	0.308828E+02	0.602316E 02	0.364145E-01
0.250E 00	0.530984E 01	0.309124E+02	0.256288E 02	0.660436E-02
0.260E 00	0.528097E 01	0.308678E+02	-0.361179E 02	0.139803E-01
0.270E 00	0.524788E 01	0.308167E+02	-0.414872E 02	0.184103E-01
0.280E 00	0.521229E 01	0.307617E+02	-0.447118E 02	0.213411E-01
0.290E 00	0.517511E 01	0.307043E+02	-0.467996E 02	0.233337E-01
0.300E 00	0.513690E 01	0.306453E+02	-0.481867E 02	0.246874E-01
0.310E 00	0.509805E 01	0.305853E+02	-0.491065E 02	0.255869E-01
0.320E 00	0.505881E 01	0.305246E+02	-0.496998E 02	0.261557E-01
0.330E 00	0.501936E 01	0.304637E+02	-0.500588E 02	0.264813E-01
0.340E 00	0.497984E 01	0.304026E+02	-0.502455E 02	0.266254E-01
0.350E 00	0.494036E 01	0.303417E+02	-0.503051E 02	0.266349E-01
0.360E 00	0.490099E 01	0.302808E+02	-0.502690E 02	0.265434E-01
0.370E 00	0.486177E 01	0.302202E+02	-0.501617E 02	0.263776E-01
0.380E 00	0.482276E 01	0.301600E+02	-0.500006E 02	0.261565E-01
0.390E 00	0.478399E 01	0.301001E+02	-0.497993E 02	0.258951E-01
0.400E 00	0.474547E 01	0.300406E+02	-0.495685E 02	0.256054E-01
0.410E 00	0.470722E 01	0.299815E+02	-0.493156E 02	0.252954E-01

Table C-IX. Fill-Time Prediction - 20% Open, 7 psi - Front Room

AREA1	VOLUME	TIME	PRESSURE	DENSITY
0.400E 02	0.600000E 04	0.100000E-01	0.147000E 02	0.399000E-02
TIME SECONDS	PRESSURE PSI	DEN3 UE-S2/F4	U2 FPS	DPT PSI
0.100E-01	0.102437E 01	0.246365E-02	0.866177E 03	0.602930E 01
0.200E-01	0.209750E 01	0.260148E-02	0.851307E 03	0.611115E 01
0.300E-01	0.319028E 01	0.274056E-02	0.819508E 03	0.593657E 01
0.400E-01	0.424990E 01	0.287565E-02	0.760893E 03	0.535339E 01
0.500E-01	0.527063E 01	0.300598E-02	0.704591E 03	0.479306E 01
0.600E-01	0.624751E 01	0.313092E-02	0.650566E 03	0.423340E 01
0.700E-01	0.717630E 01	0.324990E-02	0.598756E 03	0.371040E 01
0.800E-01	0.805344E 01	0.336244E-02	0.549069E 03	0.321835E 01
0.900E-01	0.887593E 01	0.346814E-02	0.501387E 03	0.276008E 01
0.100E 00	0.964126E 01	0.356664E-02	0.455569E 03	0.233722E 01
0.110E 00	0.103473E 02	0.365765E-02	0.411446E 03	0.195041E 01
0.120E 00	0.109923E 02	0.374092E-02	0.368820E 03	0.159956E 01
0.130E 00	0.115746E 02	0.381621E-02	0.327456E 03	0.128399E 01
0.140E 00	0.120925E 02	0.388327E-02	0.287063E 03	0.100268E 01
0.150E 00	0.125441E 02	0.394185E-02	0.247270E 03	0.754406E 00
0.160E 00	0.129272E 02	0.399161E-02	0.207552E 03	0.537903E 00
0.170E 00	0.132383E 02	0.403207E-02	0.167077E 03	0.352060E 00
0.180E 00	0.134710E 02	0.406239E-02	0.124223E 03	0.196183E 00
0.190E 00	0.136108E 02	0.408062E-02	0.742534E 02	0.705117E-01
0.200E 00	0.135366E 02	0.406992E-02	-0.394029E 02	0.219609E-01
0.210E 00	0.134316E 02	0.405479E-02	-0.559486E 02	0.440641E-01
0.220E 00	0.133139E 02	0.403783E-02	-0.630190E 02	0.555713E-01
0.230E 00	0.131895E 02	0.401989E-02	-0.669697E 02	0.625724E-01
0.240E 00	0.130612E 02	0.400141E-02	-0.693225E 02	0.667249E-01
0.250E 00	0.129311E 02	0.398265E-02	-0.707309E 02	0.691297E-01
0.260E 00	0.128000E 02	0.396376E-02	-0.715398E 02	0.703795E-01
0.270E 00	0.126688E 02	0.394485E-02	-0.719515E 02	0.709496E-01
0.280E 00	0.125380E 02	0.392600E-02	-0.720957E 02	0.707930E-01
0.290E 00	0.124079E 02	0.390725E-02	-0.720562E 02	0.703781E-01
0.300E 00	0.122787E 02	0.388863E-02	-0.718900E 02	0.697209E-01
0.310E 00	0.121506E 02	0.387016E-02	-0.716380E 02	0.689058E-01
0.320E 00	0.120237E 02	0.385186E-02	-0.713265E 02	0.679867E-01
0.330E 00	0.118979E 02	0.383373E-02	-0.709748E 02	0.670032E-01
0.340E 00	0.117734E 02	0.381579E-02	-0.705983E 02	0.659861E-01
0.350E 00	0.116502E 02	0.379802E-02	-0.702048E 02	0.649510E-01
0.360E 00	0.115282E 02	0.378044E-02	-0.698014E 02	0.639117E-01
0.370E 00	0.114075E 02	0.376305E-02	-0.693944E 02	0.628600E-01
0.380E 00	0.112880E 02	0.374583E-02	-0.689854E 02	0.618586E-01

Table C-X. Fill-Time Prediction - 20% Open, 7 psi - Both Rooms

AREA1	VOLUME	TIME	PRESSURE	DENSITY
0.400E 02	0.100000E 05	0.100000E+01	0.147000E 02	0.398000E-02
TIME SECONDS	PRESSURE PSI	DEN3 UE-S2/F4	U2 FPS	DPT PSI
0.100E+01	0.614623E 00	0.241019E+02	0.856177E 03	0.602930E 01
0.200E+01	0.124638E 01	0.249184E+02	0.856534E 03	0.607084E 01
0.300E+01	0.189512E 01	0.257491E+02	0.846604E 03	0.610464E 01
0.400E+01	0.254772E 01	0.265810E+02	0.824111E 03	0.595169E 01
0.500E+01	0.318702E 01	0.273974E+02	0.786639E 03	0.557424E 01
0.600E+01	0.381164E 01	0.281962E+02	0.750066E 03	0.520144E 01
0.700E+01	0.442035E 01	0.289760E+02	0.714386E 03	0.483547E 01
0.800E+01	0.501200E 01	0.297351E+02	0.679589E 03	0.447818E 01
0.900E+01	0.558559E 01	0.304722E+02	0.645658E 03	0.413113E 01
0.100E 00	0.614018E 01	0.311860E+02	0.612575E 03	0.379559E 01
0.110E 00	0.667496E 01	0.318753E+02	0.580315E 03	0.347261E 01
0.120E 00	0.718919E 01	0.325392E+02	0.548850E 03	0.315296E 01
0.130E 00	0.768222E 01	0.331767E+02	0.518146E 03	0.285725E 01
0.140E 00	0.815345E 01	0.337869E+02	0.488166E 03	0.258587E 01
0.150E 00	0.860237E 01	0.343691E+02	0.458870E 03	0.231907E 01
0.160E 00	0.902851E 01	0.349226E+02	0.430210E 03	0.206695E 01
0.170E 00	0.943143E 01	0.354467E+02	0.402133E 03	0.182949E 01
0.180E 00	0.981072E 01	0.359408E+02	0.374580E 03	0.160656E 01
0.190E 00	0.101660E 02	0.364043E+02	0.347483E 03	0.139804E 01
0.200E 00	0.104969E 02	0.368366E+02	0.320782E 03	0.120360E 01
0.210E 00	0.108029E 02	0.372370E+02	0.294325E 03	0.102299E 01
0.220E 00	0.110836E 02	0.376048E+02	0.268057E 03	0.855889E 00
0.230E 00	0.113385E 02	0.379392E+02	0.241814E 03	0.701974E 00
0.240E 00	0.115668E 02	0.382392E+02	0.215405E 03	0.560947E 00
0.250E 00	0.117677E 02	0.385035E+02	0.189562E 03	0.432538E 00
0.260E 00	0.119397E 02	0.387301E+02	0.160873E 03	0.316555E 00
0.270E 00	0.120809E 02	0.389165E+02	0.131636E 03	0.212932E 00
0.280E 00	0.121878E 02	0.390577E+02	0.993832E 02	0.121831E 00
0.290E 00	0.122520E 02	0.391426E+02	0.595800E 02	0.439103E-01
0.300E 00	0.122120E 02	0.390846E+02	-0.371121E 02	0.186908E-01
0.310E 00	0.121488E 02	0.389928E+02	-0.589735E 02	0.470176E-01
0.320E 00	0.120732E 02	0.388830E+02	-0.707430E 02	0.673852E-01
0.330E 00	0.119894E 02	0.387613E+02	-0.788291E 02	0.833248E-01
0.340E 00	0.118995E 02	0.386307E+02	-0.848516E 02	0.961378E-01
0.350E 00	0.118051E 02	0.384936E+02	-0.895209E 02	0.106555E 00
0.360E 00	0.117072E 02	0.383514E+02	-0.932257E 02	0.115063E 00
0.370E 00	0.116066E 02	0.382053E+02	-0.962069E 02	0.122013E 00
0.380E 00	0.115039E 02	0.380562E+02	-0.986234E 02	0.127666E 00
0.390E 00	0.113996E 02	0.379048E+02	-0.100589E 03	0.132231E 00
0.400E 00	0.112942E 02	0.377516E+02	-0.102187E 03	0.135875E 00
0.410E 00	0.111878E 02	0.375971E+02	-0.103480E 03	0.138734E 00

Table C-XI. Fill-Time Prediction - 20% Open, 10 psi - Front Room

AREA1	VOLUME	TIME	PRESSURE	DENSITY
0.400E 02	0.600000E 04	0.100000E+01	0.147000E 02	0.471000E-02
TIME SECONDS	PRESSURE PSI	DEN 3 UE-S2/F4	U2 FPS	DPT PSI
0.100E+01	0.112527E 01	0.247439E+02	0.940010E 03	0.705906E 01
0.200E+01	0.231370E 01	0.262433E+02	0.926049E 03	0.723181E 01
0.300E+01	0.356594E 01	0.277971E+02	0.911281E 03	0.737474E 01
0.400E+01	0.488221E 01	0.294038E+02	0.895687E 03	0.749523E 01
0.500E+01	0.626226E 01	0.310613E+02	0.879250E 03	0.759072E 01
0.600E+01	0.765818E 01	0.327250E+02	0.840609E 03	0.728404E 01
0.700E+01	0.900574E 01	0.343346E+02	0.776637E 03	0.651057E 01
0.800E+01	0.102970E 02	0.358802E+02	0.715247E 03	0.575771E 01
0.900E+01	0.115252E 02	0.373534E+02	0.656391E 03	0.503636E 01
0.100E 00	0.126845E 02	0.387469E+02	0.599983E 03	0.435460E 01
0.110E 00	0.137701E 02	0.400545E+02	0.545899E 03	0.371603E 01
0.120E 00	0.147781E 02	0.412712E+02	0.493976E 03	0.313013E 01
0.130E 00	0.157050E 02	0.423923E+02	0.444019E 03	0.259265E 01
0.140E 00	0.165479E 02	0.434139E+02	0.395792E 03	0.210600E 01
0.150E 00	0.173043E 02	0.443325E+02	0.349966E 03	0.166954E 01
0.160E 00	0.179714E 02	0.451443E+02	0.303190E 03	0.128197E 01
0.170E 00	0.185462E 02	0.458452E+02	0.257936E 03	0.941611E 00
0.180E 00	0.190246E 02	0.464297E+02	0.212429E 03	0.646673E 00
0.190E 00	0.194000E 02	0.468892E+02	0.165310E 03	0.395632E 00
0.200E 00	0.196591E 02	0.472070E+02	0.113437E 03	0.187775E 00
0.210E 00	0.197529E 02	0.473223E+02	0.409276E 02	0.245757E-01
0.220E 00	0.195911E 02	0.471001E+02	-0.708278E 02	0.819996E-01
0.230E 00	0.194090E 02	0.468500E+02	-0.801745E 02	0.104424E 00
0.240E 00	0.192150E 02	0.465836E+02	-0.859544E 02	0.119268E 00
0.250E 00	0.190138E 02	0.463071E+02	-0.897675E 02	0.129255E 00
0.260E 00	0.188080E 02	0.460245E+02	-0.923446E 02	0.135907E 00
0.270E 00	0.185998E 02	0.457385E+02	-0.940882E 02	0.140180E 00
0.280E 00	0.183903E 02	0.454508E+02	-0.952442E 02	0.142721E 00
0.290E 00	0.181806E 02	0.451627E+02	-0.959751E 02	0.143987E 00
0.300E 00	0.179713E 02	0.448753E+02	-0.963947E 02	0.144317E 00
0.310E 00	0.177630E 02	0.445891E+02	-0.965830E 02	0.143954E 00
0.320E 00	0.175559E 02	0.443047E+02	-0.965970E 02	0.143077E 00
0.330E 00	0.173504E 02	0.440225E+02	-0.964805E 02	0.141825E 00
0.340E 00	0.171467E 02	0.437427E+02	-0.962674E 02	0.140305E 00
0.350E 00	0.169449E 02	0.434654E+02	-0.959872E 02	0.138596E 00
0.360E 00	0.167450E 02	0.431909E+02	-0.956427E 02	0.136754E 00
0.370E 00	0.165472E 02	0.429191E+02	-0.952636E 02	0.134826E 00
0.380E 00	0.163514E 02	0.426502E+02	-0.948573E 02	0.132847E 00
0.390E 00	0.161577E 02	0.423842E+02	-0.944319E 02	0.130845E 00
0.400E 00	0.159661E 02	0.421210E+02	-0.939930E 02	0.128833E 00

Table C-XII. Fill-Time Prediction - 20% Open, 10 psi - Both Rooms

AREA1	VOLUME	TIME	PRESSURE	DENSITY
0.400E 02	0.100000E 05	0.100000E+01	0.147000E 02	0.471000E-02
TIME SECONDS	PRESSURE PSI	DEN 3 UE-S2/F4	U2 FPS	DPT PSI
0.100E+01	0.675162E 00	0.241663E+02	0.940010F 03	0.706906F 01
0.200E-01	0.137247E 01	0.250521E+02	0.930738F 03	0.715620F 01
0.300E-01	0.209199E 01	0.259569E+02	0.921151F 03	0.723517E 01
0.400E-01	0.283372E 01	0.268805E+02	0.911245E 03	0.730536F 01
0.500E-01	0.359758E 01	0.278223F+02	0.901014E 03	0.736622F 01
0.600E-01	0.438343E 01	0.287818E+02	0.890456E 03	0.741710F 01
0.700E-01	0.519108E 01	0.297586E+02	0.879566E 03	0.745747E 01
0.800E-01	0.602022E 01	0.307518E+02	0.868343E 03	0.748679F 01
0.900E+01	0.683384E 01	0.317278E+02	0.828686F 03	0.702040E 01
0.100E 00	0.762725E 01	0.326815E+02	0.787819E 03	0.652202F 01
0.110E 00	0.839862E 01	0.336106E+02	0.747956E 03	0.603261E 01
0.120E 00	0.914632E 01	0.345131E+02	0.709085E 03	0.555502E 01
0.130E 00	0.986885E 01	0.353870E+02	0.571189E 03	0.509166F 01
0.140E 00	0.105649E 02	0.362306E+02	0.634243E 03	0.464455E 01
0.150E 00	0.112338E 02	0.370423E+02	0.598218F 03	0.421519E 01
0.160E 00	0.118730E 02	0.378208E+02	0.563076E 03	0.380480F 01
0.170E 00	0.124830E 02	0.385646E+02	0.528775E 03	0.341427E 01
0.180E 00	0.130626E 02	0.392727E+02	0.495263E 03	0.304417F 01
0.190E 00	0.136109E 02	0.399439E+02	0.462482E 03	0.269483F 01
0.200E 00	0.141273E 02	0.405774E+02	0.430365E 03	0.235636E 01
0.210E 00	0.146111E 02	0.411720E+02	0.398835E 03	0.205874E 01
0.220E 00	0.150618E 02	0.417270F+02	0.357747E 03	0.177173F 01
0.230E 00	0.154786E 02	0.422412E+02	0.337142E 03	0.150501F 01
0.240E 00	0.158609E 02	0.427138E+02	0.306734E 03	0.125821F 01
0.250E 00	0.162078E 02	0.431434E+02	0.276399E 03	0.103087F 01
0.260E 00	0.165184E 02	0.435288E+02	0.245904E 03	0.822555F 00
0.270E 00	0.167912E 02	0.438680E+02	0.214920F 03	0.632834E 00
0.280E 00	0.170245E 02	0.441585F+02	0.182940E 03	0.461373E 00
0.290E 00	0.172152E 02	0.443965F+02	0.149078E 03	0.308000F 00
0.300E 00	0.173582E 02	0.445752E+02	0.111446E 03	0.172867E 00
0.310E 00	0.174401E 02	0.446778E+02	0.638177E 02	0.568660E-01
0.320E 00	0.173776E 02	0.445909E+02	-0.467845E 02	0.368273F-01
0.330E 00	0.172840E 02	0.444607E+02	-0.733882E 02	0.829166F-01
0.340E 00	0.171724E 02	0.443057E+02	-0.878877E 02	0.118282E 00
0.350E 00	0.170484E 02	0.441332E+02	-0.982904E 02	0.147129F 00
0.360E 00	0.169149E 02	0.439478F+02	-0.106315E 03	0.171173F 00
0.370E 00	0.167742E 02	0.437522E+02	-0.112747E 03	0.191426E 00
0.380E 00	0.166278E 02	0.435486F+02	-0.118025E 03	0.209574E 00
0.390E 00	0.164768E 02	0.433386E+02	-0.122421E 03	0.223114F 00
0.400E 00	0.163220E 02	0.431236F+02	-0.126121E 03	0.235446F 00

APPENDIX D

PREDICTED TRANSLATION PARAMETERS FOR EXPERIMENTAL MODEL

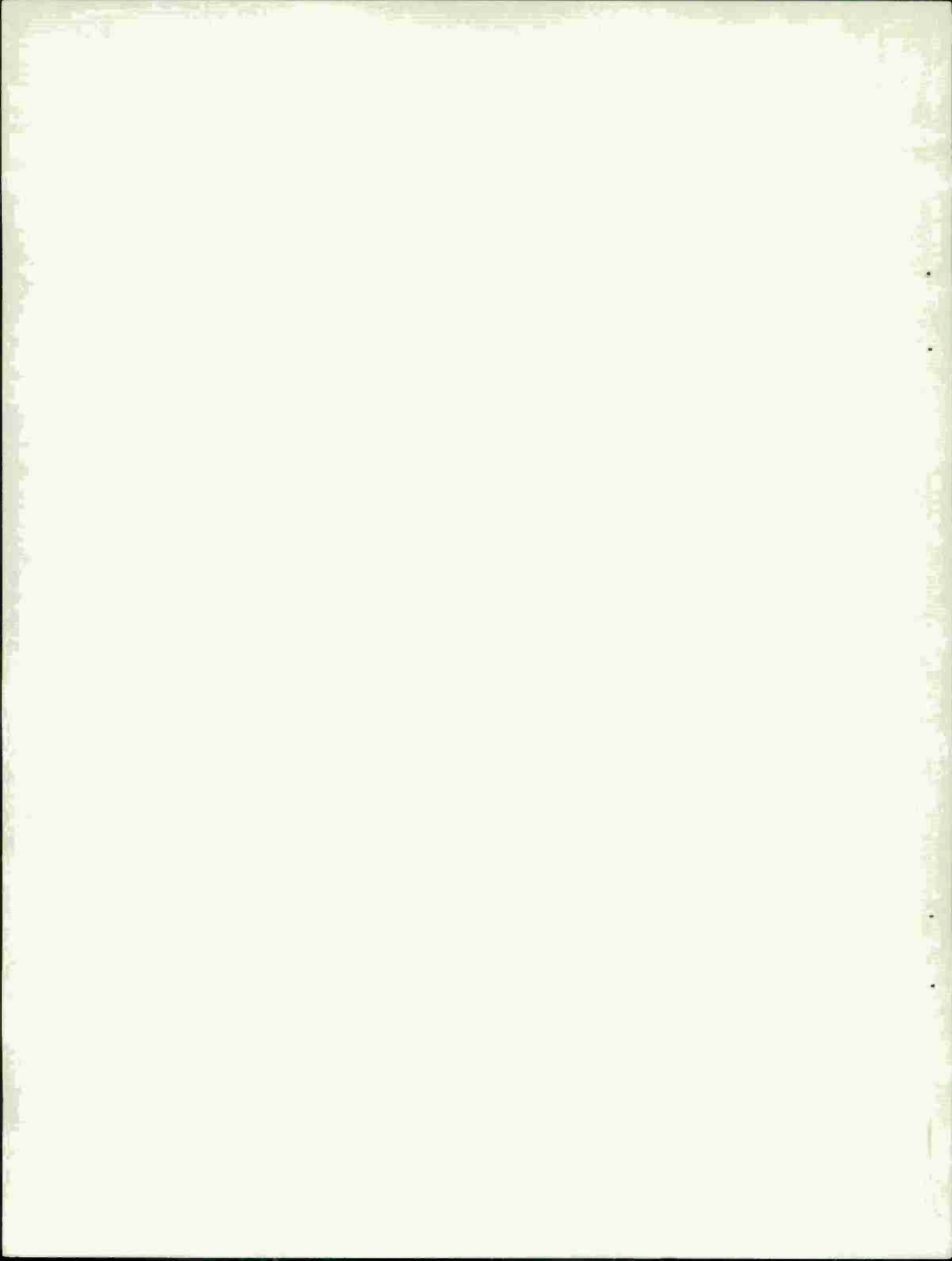


Table D-I. Predicted Translation Parameters - Prone at Entrance - 49% Open, 3.6 psi

TWO-ROOM MODEL - V/A=5.1FT

SHOT 24-75-158, 3.6PSI

TIME-SEC	DISTANCE-FT	VELOCITY-FT/SEC	ACCEL.-FT/SEC/SEC
0.0005	0.0001	0.3465	692.9416
0.0010	0.0003	0.6415	590.0994
0.0015	0.0007	0.8889	494.7132
0.0020	0.0012	1.0930	408.2619
0.0025	0.0018	1.2584	330.7273
0.0030	0.0025	1.3896	262.5059
0.0035	0.0032	1.4912	203.1498
0.0040	0.0039	1.5672	151.9977
0.0045	0.0047	1.6216	108.8187
0.0050	0.0056	1.6582	73.1846
0.0055	0.0064	1.6805	44.5978
0.0060	0.0072	1.6918	22.6858
0.0065	0.0081	1.6956	7.4316

TWO-ROOM MODEL - V/A=8.54FT

SHOT 24-75-158, 3.6PSI

TIME-SEC	DISTANCE-FT	VELOCITY-FT/SEC	ACCEL.-FT/SEC/SEC
0.0005	0.0001	0.3465	692.9416
0.0010	0.0003	0.6618	630.6762
0.0015	0.0007	0.9474	571.0880
0.0020	0.0013	1.2045	514.3852
0.0025	0.0019	1.4349	460.7789
0.0030	0.0027	1.6402	410.4718
0.0035	0.0036	1.8219	363.4553
0.0040	0.0045	1.9817	319.5085
0.0045	0.0055	2.1212	279.0434
0.0050	0.0066	2.2420	241.6573
0.0055	0.0078	2.3457	207.3008
0.0060	0.0090	2.4336	175.9866
0.0065	0.0102	2.5074	147.4947
0.0070	0.0115	2.5683	121.8131
0.0075	0.0128	2.6178	98.9351
0.0080	0.0141	2.6570	78.4328
0.0085	0.0154	2.6872	60.5181
0.0090	0.0168	2.7097	44.9656
0.0095	0.0181	2.7256	31.7770
0.0100	0.0195	2.7360	20.7381
0.0105	0.0209	2.7419	11.8516
0.0110	0.0223	2.7446	5.3256

Table D-II. Predicted Translation Parameters - Prone at  
Entrance - 49% Open, 10.9 psi

TWO-ROOM MODEL-V/A=5.1FT

SHOT 24-75-159, 10.9PSI

TIME-SEC	DISTANCE-FT	VELOCITY-FT/SEC	ACCEL.-FT/SEC/SEC
0.0005	0.0002	0.8128	1625.5504
0.0010	0.0008	1.6610	1696.4279
0.0015	0.0019	2.5411	1760.1534
0.0020	0.0034	3.4488	1815.4478
0.0025	0.0053	4.3789	1860.1744
0.0030	0.0077	5.2208	1683.9064
0.0035	0.0105	5.9424	1443.2277
0.0040	0.0136	6.5490	1214.9321
0.0045	0.0170	7.0518	1003.8355
0.0050	0.0207	7.4583	813.0308
0.0055	0.0245	7.7803	643.9319
0.0060	0.0284	8.0287	496.8004
0.0065	0.0325	8.2141	370.8699
0.0070	0.0366	8.3466	264.9650
0.0075	0.0408	8.4357	178.1326
0.0080	0.0451	8.4901	108.8254

TWO-ROOM MODEL-V/A=8.54FT

SHOT 24-75-159, 10.9PSI

TIME-SEC	DISTANCE-FT	VELOCITY-FT/SEC	ACCEL.-FT/SEC/SEC
0.0005	0.0002	0.8128	1625.5504
0.0010	0.0008	1.6470	1668.3566
0.0015	0.0019	2.5013	1708.7171
0.0020	0.0033	3.3745	1746.4056
0.0025	0.0052	4.2648	1780.5826
0.0030	0.0076	5.1704	1811.2319
0.0035	0.0104	6.0893	1837.7472
0.0040	0.0137	7.0151	1851.6261
0.0045	0.0174	7.8670	1703.7149
0.0050	0.0215	8.6458	1557.6734
0.0055	0.0260	9.3533	1415.0005
0.0060	0.0309	9.9920	1277.4344
0.0065	0.0360	10.5649	1145.8081
0.0070	0.0414	11.0755	1021.1070
0.0075	0.0471	11.5274	903.7635
0.0080	0.0529	11.9245	794.3247
0.0085	0.0590	12.2708	692.5814
0.0090	0.0652	12.5703	598.9027
0.0095	0.0715	12.8267	512.7894
0.0100	0.0780	13.0440	434.6444
0.0105	0.0846	13.2259	363.7979
0.0110	0.0912	13.3759	299.9978
0.0115	0.0979	13.4975	243.1730
0.0120	0.1047	13.5939	192.9014
0.0125	0.1115	13.6683	148.7404
0.0130	0.1184	13.7236	110.6379
0.0135	0.1253	13.7628	78.3971
0.0140	0.1321	13.7886	51.5729

Table D-III. Predicted Translation Parameters - Prone at Entrance - 20% Open, 3.6 psi

TWO-ROOM MODEL - V/A = 12.5 FT

SHOT 24-75-162, 3.6 PSI

TIME-SEC	DISTANCE-FT	VELOCITY-FT/SEC	ACCEL.-FT/SEC/SEC
0.0005	0.0001	0.3609	721.7786
0.0010	0.0004	0.6998	677.8319
0.0015	0.0008	1.0173	635.0327
0.0020	0.0014	1.3141	593.5968
0.0025	0.0021	1.5909	553.5143
0.0030	0.0030	1.8483	514.7919
0.0035	0.0039	2.0872	477.8476
0.0040	0.0050	2.3083	442.2518
0.0045	0.0062	2.5123	408.0011
0.0050	0.0075	2.7001	375.5171
0.0055	0.0089	2.8724	344.5910
0.0060	0.0104	3.0300	315.2028
0.0065	0.0120	3.1737	287.3647
0.0070	0.0136	3.3042	261.0646
0.0075	0.0153	3.4222	236.0868
0.0080	0.0170	3.5286	212.6471
0.0085	0.0188	3.6239	190.7258
0.0090	0.0206	3.7090	170.1232
0.0095	0.0225	3.7844	150.8285
0.0100	0.0244	3.8508	132.8385
0.0105	0.0263	3.9089	116.1499
0.0110	0.0283	3.9593	100.7598
0.0115	0.0303	4.0025	86.4611
0.0120	0.0323	4.0392	73.4546
0.0130	0.0364	4.1007	61.5004

Table D-III. (Cont'd) Predicted Translation Parameters -  
 Prone at Entrance - 20% Open, 3.6 psi

TWO-ROOM MODEL - V/A = 20.83 FT

SHOT 24-75-162, 3.6 PSI

TIME-SEC	DISTANCE-FT	VELOCITY-FT/SEC	ACCEL.-FT/SEC/SEC
0.0010	0.0004	0.7218	721.7786
0.0020	0.0014	1.3901	668.2803
0.0030	0.0031	2.0070	616.8991
0.0040	0.0054	2.5744	567.4144
0.0050	0.0082	3.0944	520.0415
0.0060	0.0116	3.5692	474.7648
0.0070	0.0154	4.0010	431.7860
0.0080	0.0196	4.3923	391.3053
0.0090	0.0241	4.7452	352.9007
0.0100	0.0290	5.0621	316.9575
0.0110	0.0342	5.3452	283.0682
0.0120	0.0397	5.5968	251.6295
0.0130	0.0454	5.8190	222.2216
0.0140	0.0513	6.0141	195.0300
0.0150	0.0574	6.1839	169.8341
0.0160	0.0637	6.3305	146.6240
0.0170	0.0701	6.4559	125.3901
0.0180	0.0766	6.5619	105.9254
0.0190	0.0832	6.6501	88.2110
0.0200	0.0899	6.7225	72.4451
0.0210	0.0966	6.7807	58.2156
0.0220	0.1034	6.8262	45.5089
0.0230	0.1103	6.8608	34.5234
0.0240	0.1171	6.8858	25.0505
0.0250	0.1240	6.9027	16.8943

Table D-IV. Predicted Translation Parameters - Prone at Entrance - 20% Open, 7.5 psi

TWO-ROOM MODEL - V/A = 12.5 FT

PREDICTED, 7.5 PSI

TIME-SEC	DISTANCE-FT	VELOCITY-FT/SEC	ACCEL.-FT/SEC/SEC
0.0005	0.0002	0.6709	1341.8801
0.0015	0.0015	2.0274	1356.4211
0.0025	0.0042	3.4085	1381.1170
0.0035	0.0083	4.7145	1306.0241
0.0045	0.0136	5.8784	1163.9135
0.0055	0.0200	6.9051	1026.6481
0.0065	0.0273	7.8012	896.1694
0.0075	0.0355	8.5752	773.9370
0.0085	0.0444	9.2361	660.9580
0.0095	0.0539	9.7939	557.7972
0.0105	0.0640	10.2587	464.7657
0.0115	0.0744	10.6401	381.4223
0.0125	0.0852	10.9475	307.4206
0.0135	0.0963	11.1905	242.9363
0.0145	0.1076	11.3773	186.8307
0.0155	0.1190	11.5161	138.8110
0.0175	0.1422	11.7134	98.6430
0.0195	0.1658	11.7924	39.5224
0.0200	0.1716	11.7959	6.8372

Table D-IV. (Cont'd) Predicted Translation Parameters -  
 Prone at Entrance - 20% Open, 7.5 psi

TWO-ROOM MODEL  $\bar{V}/A=20.83\text{FT}$

PREDICTED, 7.5PSI

TIME-SEC	DISTANCE-FT	VELOCITY-FT/SEC	ACCEL. -FT/SEC/SEC
0.0030	0.0060	4.0256	1341.8801
0.0040	0.0108	5.4074	1381.8066
0.0050	0.0168	6.7215	1314.0636
0.0060	0.0242	7.9482	1226.7004
0.0070	0.0327	9.0889	1140.7013
0.0080	0.0423	10.1454	1056.4648
0.0090	0.0529	11.1203	974.8829
0.0100	0.0645	12.0163	896.0636
0.0110	0.0769	12.8366	820.3018
0.0120	0.0901	13.5848	748.1591
0.0130	0.1041	14.2640	679.2468
0.0140	0.1186	14.8784	614.3228
0.0160	0.1495	15.9838	552.7364
0.0180	0.1823	16.8655	440.8359
0.0200	0.2168	17.5529	343.6872
0.0210	0.2344	17.8133	260.4733
0.0220	0.2524	18.0370	223.6788
0.0230	0.2705	18.2272	190.2029
0.0240	0.2888	18.3870	159.8204
0.0250	0.3073	18.5194	132.3385
0.0270	0.3445	18.7348	107.7044
0.0290	0.3821	18.8674	66.3260
0.0310	0.4199	18.9379	35.2179
0.0320	0.4389	18.9516	13.7207
0.0330	0.4578	18.9582	6.5857

Table D-V. Predicted Translation Parameters - Prone at Entrance - 20% Open, 10.9 psi

TWO-ROOM MODEL - V/A = 12.5 FT

SHOT 24-75-172, 10.9 PSI

TIME-SEC	DISTANCE-FT	VELOCITY-FT/SEC	ACCEL.-FT/SEC/SEC
0.0010	0.0008	1.5956	1595.6454
0.0020	0.0032	3.2433	1647.6479
0.0035	0.0100	5.7883	1696.7029
0.0045	0.0167	7.5444	1756.0464
0.0050	0.0207	8.4374	1786.1092
0.0055	0.0251	9.3083	1741.6149
0.0060	0.0299	10.1294	1642.3134
0.0070	0.0409	11.6749	1545.4998
0.0080	0.0532	13.0320	1357.1050
0.0090	0.0668	14.2087	1176.6556
0.0095	0.0741	14.7139	1010.3987
0.0105	0.0892	15.6449	931.0713
0.0115	0.1053	16.4288	783.8353
0.0125	0.1220	17.0793	650.4862
0.0135	0.1394	17.6101	530.8769
0.0145	0.1572	18.0370	426.8877
0.0155	0.1754	18.3713	334.2801
0.0165	0.1939	18.6263	254.9788
0.0175	0.2126	18.8151	188.7941
0.0185	0.2315	18.9471	131.9690
0.0195	0.2505	19.0335	86.4197
0.0205	0.2695	19.0841	50.6739

Table D-V. (Cont'd) Predicted Translation Parameters -  
 Prone at Entrance - 20% Open, 10.9 psi

TWO-ROOM MODEL - V/A = 20.83 FT

SHOT 24-75-172, 10.9 PSI

TIME-SEC	DISTANCE-FT	VELOCITY-FT/SEC	ACCEL.-FT/SEC/SEC
0.0020	0.0032	3.1913	1595.6454
0.0040	0.0129	6.5005	1654.6274
0.0060	0.0293	9.9069	1703.1934
0.0080	0.0526	13.3940	1743.5291
0.0090	0.0669	15.1550	1760.9783
0.0100	0.0828	16.7941	1639.1480
0.0110	0.1004	18.3144	1520.3317
0.0120	0.1194	19.7191	1404.6318
0.0130	0.1398	21.0109	1291.8596
0.0140	0.1614	22.1931	1182.2074
0.0150	0.1841	23.2709	1077.7306
0.0170	0.2326	25.2273	978.1943
0.0190	0.2847	26.8154	794.0485
0.0210	0.3395	28.0788	631.7162
0.0230	0.3967	29.0566	488.9138
0.0250	0.4555	29.7946	368.9940
0.0290	0.5769	30.8647	267.5278
0.0310	0.6388	31.1011	118.1675
0.0330	0.7012	31.2359	67.4289
0.0350	0.7637	31.2980	31.0174
0.0360	0.7950	31.3063	8.3127
0.0370	0.8263	31.3085	2.2730

Table D-VI. Predicted Translation Parameters - Standing  
at Entrance - 49% Open, 3.6 psi

TWO-ROOM MODEL - V/A = 5.1 FT

SHOT 24-75-158, 3.6 PSI

TIME-SEC	DISTANCE-FT	VELOCITY-FT/SEC	ACCEL.-FT/SEC/SEC
0.0005	0.0007	2.6652	5330.3199
0.0010	0.0026	4.9158	4501.3255
0.0015	0.0055	6.7850	3740.0757
0.0020	0.0093	8.3143	3056.9082
0.0025	0.0137	9.5396	2450.5851
0.0030	0.0187	10.5008	1922.4486
0.0035	0.0242	11.2348	1467.9110
0.0040	0.0299	11.7752	1080.7767
0.0045	0.0359	12.1543	758.3314
0.0050	0.0420	12.4020	497.1527
0.0055	0.0483	12.5480	290.0891
0.0060	0.0546	12.5164	136.8077
0.0065	0.0609	12.6346	36.4193

TWO-ROOM MODEL - V/A = 8.54 FT

SHOT 24-75-158, 3.6 PSI

TIME-SEC	DISTANCE-FT	VELOCITY-FT/SEC	ACCEL.-FT/SEC/SEC
0.0005	0.0007	2.6652	5330.3199
0.0010	0.0026	5.0717	4813.0101
0.0015	0.0057	7.2330	4322.6217
0.0020	0.0098	9.1632	3860.3550
0.0025	0.0148	10.8770	3427.5999
0.0030	0.0206	12.3896	3025.2521
0.0035	0.0271	13.7159	2652.7347
0.0040	0.0343	14.8699	2307.8985
0.0045	0.0420	15.8664	1993.0917
0.0050	0.0501	16.7196	1706.3308
0.0055	0.0586	17.4420	1444.7934
0.0060	0.0675	18.0466	1209.1382
0.0065	0.0767	18.5452	997.3249
0.0070	0.0860	18.9496	808.6674
0.0075	0.0956	19.2710	642.7684
0.0080	0.1053	19.5191	496.2968
0.0085	0.1151	19.7045	370.7665
0.0090	0.1250	19.8364	263.9155
0.0095	0.1349	19.9244	175.8202
0.0100	0.1449	19.9768	104.8250
0.0105	0.1549	20.0023	51.0773
0.0110	0.1649	20.0103	15.9436

Table D-VII, Predicted Translation Parameters - Standing  
at Entrance - 49% Open, 10.9 psi

TWO-ROOM MODEL-V/A=5.1FT

SHOT 24-75-159, 10.9PSI

TIME-SEC	DISTANCE-FT	VELOCITY-FT/SEC	ACCEL.-FT/SEC/SEC
0.0005	0.0016	6.2521	12504.2339
0.0010	0.0063	12.6991	12893.9678
0.0015	0.0143	19.3017	13205.1049
0.0020	0.0256	26.0162	13429.1540
0.0025	0.0403	32.7917	13550.9765
0.0030	0.0582	38.7997	12015.9394
0.0035	0.0789	43.8239	10048.4013
0.0040	0.1018	47.9395	8231.1460
0.0045	0.1266	51.2366	6594.2865
0.0050	0.1529	53.8138	5154.3345
0.0055	0.1803	55.7720	3916.4913
0.0060	0.2085	57.2089	2873.8400
0.0065	0.2374	58.2159	2013.8707
0.0070	0.2667	58.8770	1322.1737
0.0075	0.2962	59.2704	786.7797
0.0080	0.3259	59.4671	393.5639

Table D-VII. (Cont'd) Predicted Translation Parameters - Standing  
at Entrance - 49% Open, 10.9 psi

TWO-ROOM MODEL-V/A=8.54FT

SHOT 24-75-159, 10.9PSI

TIME-SEC	DISTANCE-FT	VELOCITY-FT/SEC	ACCEL.-FT/SEC/SEC
0.0005	0.0016	6.2521	12504.2339
0.0010	0.0063	12.5943	12684.4280
0.0015	0.0142	19.0109	12833.1373
0.0020	0.0253	25.4852	12948.6320
0.0025	0.0397	31.9982	13025.8753
0.0030	0.0573	38.5305	13064.6448
0.0035	0.0782	45.0618	13062.6561
0.0040	0.1024	51.5405	12957.2971
0.0045	0.1296	57.3764	11671.8572
0.0050	0.1596	62.5931	10433.4391
0.0055	0.1920	67.2193	9252.4989
0.0060	0.2267	71.2905	8142.3502
0.0065	0.2632	74.8441	7107.0979
0.0070	0.3014	77.9188	6149.5440
0.0075	0.3410	80.5549	5272.0821
0.0080	0.3818	82.7919	4474.0482
0.0085	0.4237	84.6685	3753.0961
0.0090	0.4664	86.2229	3108.8644
0.0095	0.5098	87.4900	2534.2037
0.0100	0.5538	88.5053	2030.5270
0.0105	0.5983	89.3009	1591.2250
0.0110	0.6431	89.9072	1212.5700
0.0115	0.6882	90.3528	891.2774
0.0120	0.7334	90.6648	624.0519
0.0125	0.7788	90.8683	406.9461
0.0130	0.8243	90.9872	237.8751
0.0135	0.8698	91.0450	115.4911
0.0140	0.9153	91.0633	36.6587

Table D-VIII. Predicted Translation Parameters - Standing  
at Entrance - 20% Open, 3.6 psi

TWO-ROOM MODEL-V/A=12.5FT

SHOT 24-75-162, 3.6PSI

TIME-SEC	DISTANCE-FT	VELOCITY-FT/SEC	ACCEL.-FT/SEC/SEC
0.0005	0.0007	2.7761	5552.1427
0.0010	0.0027	5.3626	5173.1036
0.0015	0.0060	7.7664	4807.4894
0.0020	0.0105	9.9949	4456.9889
0.0025	0.0160	12.0553	4120.9434
0.0030	0.0225	13.9552	3799.6532
0.0035	0.0299	15.7031	3495.8051
0.0040	0.0381	17.3060	3205.8952
0.0045	0.0472	18.7708	2929.6744
0.0050	0.0569	20.1059	2670.0393
0.0055	0.0672	21.3186	2425.5548
0.0060	0.0782	22.4162	2195.0698
0.0065	0.0896	23.4058	1979.1950
0.0070	0.1015	24.2944	1777.2199
0.0075	0.1139	25.0881	1587.3637
0.0080	0.1266	25.7937	1411.3295
0.0085	0.1397	26.4178	1248.0441
0.0090	0.1530	26.9660	1096.5750
0.0095	0.1666	27.4442	956.3215
0.0100	0.1804	27.8578	827.0967
0.0105	0.1945	28.2121	708.7197
0.0110	0.2086	28.5126	601.0126
0.0115	0.2230	28.7640	502.6655
0.0120	0.2374	28.9713	414.6352
0.0130	0.2665	29.3054	334.0833

Table D-VIII. (Cont'd) Predicted Translation Parameters - Standing  
at Entrance - 20% Open, 3.6 psi

TWO-ROOM MODEL-V/A=20.83FT

SHOT 24-75-162, 3.6PSI

TIME-SEC	DISTANCE-FT	VELOCITY-FT/SEC	ACCEL.-FT/SEC/SEC
0.0010	0.0028	5.5521	5552.1427
0.0020	0.0109	10.6112	5059.0520
0.0030	0.0238	15.2055	4594.2684
0.0040	0.0410	19.3608	4155.3062
0.0050	0.0623	23.1043	3743.4854
0.0060	0.0871	26.4618	3357.5050
0.0070	0.1150	29.4598	2997.9963
0.0080	0.1458	32.1253	2665.5398
0.0090	0.1791	34.4821	2356.8181
0.0100	0.2146	36.5547	2072.6304
0.0110	0.2521	38.3652	1810.4930
0.0120	0.2913	39.9371	1571.8797
0.0130	0.3319	41.2908	1353.7007
0.0140	0.3737	42.4468	1156.0140
0.0150	0.4167	43.4236	976.7188
0.0160	0.4605	44.2388	815.2234
0.0170	0.5051	44.9097	670.9661
0.0180	0.5503	45.4523	542.5428
0.0190	0.5959	45.8813	429.0128
0.0200	0.6420	46.2125	331.2070
0.0210	0.6883	46.4591	246.5564
0.0220	0.7349	46.6335	174.4585
0.0230	0.7815	46.7493	115.7791
0.0240	0.8283	46.8185	69.1855
0.0250	0.8752	46.8524	33.8933

Table D-IX. Predicted Translation Parameters - Standing  
at Entrance - 20% Open, 7.5 psi

TWO-ROOM MODEL - V/A = 12.5 FT

PREDICTED, 7.5 PSI

TIME-SEC	DISTANCE-FT	VELOCITY-FT/SEC	ACCEL.-FT/SEC/SEC
0.0005	0.0013	5.1611	10322.1547
0.0015	0.0116	15.4863	10325.1793
0.0025	0.0322	25.7718	10285.5655
0.0035	0.0628	35.2576	9485.7489
0.0045	0.1021	43.4717	8214.1646
0.0055	0.1491	50.4974	7025.6258
0.0065	0.2026	56.4307	5933.3465
0.0075	0.2615	61.3750	4944.2967
0.0085	0.3249	65.4361	4061.0947
0.0095	0.3920	68.7187	3282.6470
0.0105	0.4620	71.3235	2604.7301
0.0115	0.5343	73.3453	2021.8314
0.0125	0.6084	74.8702	1524.9235
0.0135	0.6838	75.9829	1112.7185
0.0145	0.7602	76.7563	773.3276
0.0155	0.8372	77.2575	501.2694
0.0175	0.9923	77.8444	293.4396
0.0195	1.1481	77.9380	46.7841
0.0200	1.1871	77.9438	11.6747

Table D-IX. (Cont'd) Predicted Translation Parameters - Standing  
at Entrance - 20% Open, 7.5 psi

TWO-ROOM MODEL-V/A=20.83FT

PREDICTED, 7.5PSI

TIME-SEC	DISTANCE-FT	VELOCITY-FT/SEC	ACCEL.-FT/SEC/SEC
0.0030	0.0464	30.9665	10322.1547
0.0040	0.0824	40.9150	9948.5269
0.0050	0.1279	50.1378	9222.8344
0.0060	0.1822	58.5149	8377.0952
0.0070	0.2445	66.0882	7573.2521
0.0080	0.3140	72.8995	6811.3646
0.0090	0.3900	78.9978	6098.3032
0.0100	0.4717	84.4267	5428.8850
0.0110	0.5585	89.2342	4807.4353
0.0120	0.6499	93.4678	4233.6382
0.0130	0.7452	97.1726	3704.8419
0.0140	0.8440	100.3946	3221.9322
0.0160	1.0503	105.9521	2778.7861
0.0180	1.2663	109.9715	2009.6942
0.0200	1.4890	112.7540	1391.2510
0.0210	1.6022	113.6608	906.7993
0.0220	1.7162	114.3707	709.8609
0.0230	1.8308	114.9112	540.5508
0.0240	1.9460	115.3080	396.7678
0.0250	2.0614	115.5854	277.3818
0.0270	2.2929	115.9466	180.6175
0.0290	2.5249	116.0474	50.3821
0.0310	2.7570	116.0490	0.7886

Table D-X. Predicted Translation Parameters - Standing  
at Entrance - 20% Open, 10.9 psi

TWO-ROOM MODEL-V/A=12.5FT

SHOT 24-75-172, 10.9PSI

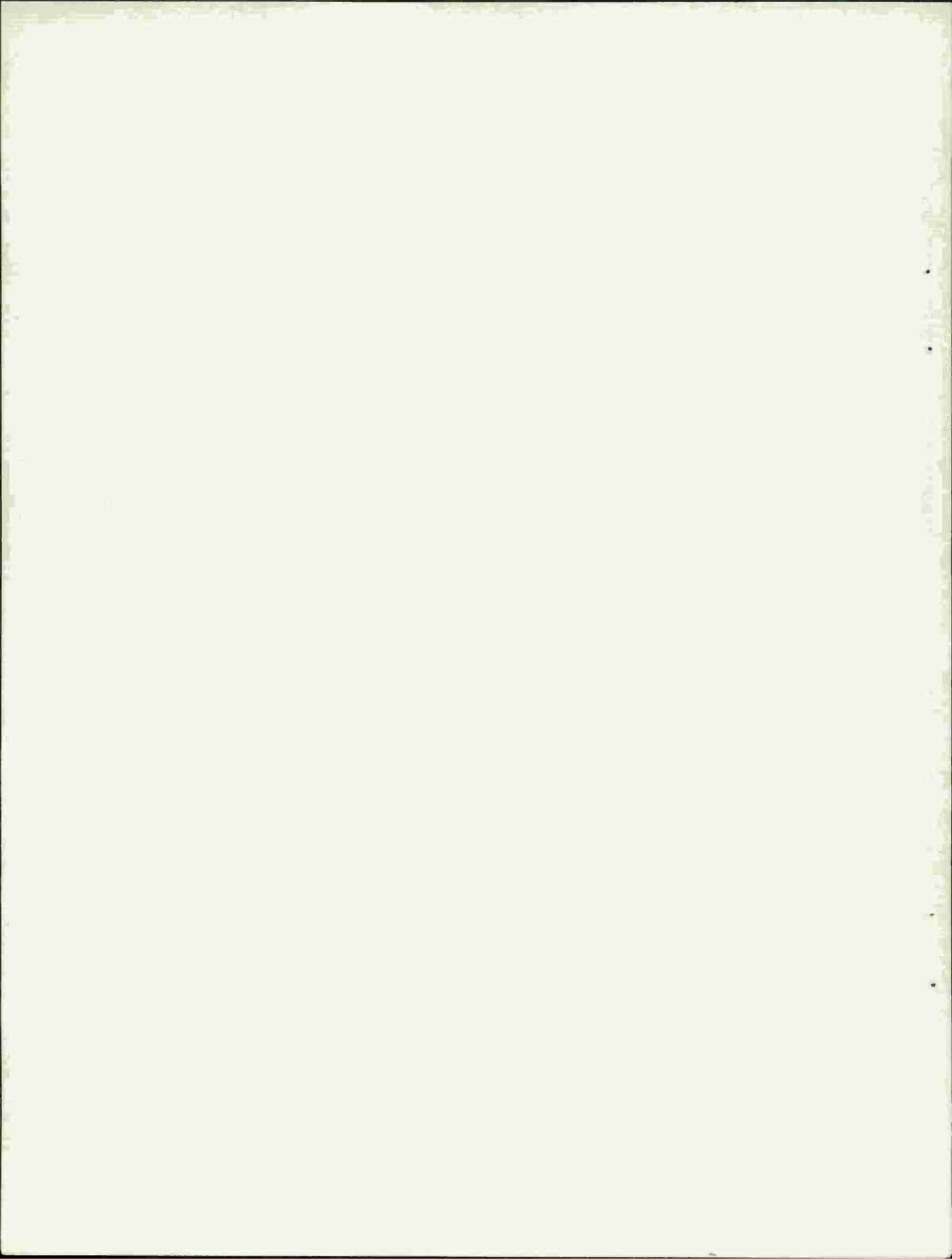
TIME-SEC	DISTANCE-FT	VELOCITY-FT/SEC	ACCEL.-FT/SEC/SEC
0.0010	0.0061	12.2742	12274.1954
0.0020	0.0246	24.6584	12384.1822
0.0035	0.0756	43.3223	12442.6040
0.0045	0.1251	55.6967	12374.4561
0.0050	0.1545	61.8138	12234.0438
0.0055	0.1868	67.6783	11729.0103
0.0060	0.2220	73.0993	10842.1405
0.0070	0.3001	83.0938	9994.4337
0.0080	0.3874	91.4846	8390.8681
0.0090	0.4824	98.4114	6926.7429
0.0095	0.5323	101.2299	5636.9728
0.0105	0.6360	106.2775	5047.6280
0.0115	0.7443	110.2646	3987.1499
0.0125	0.8561	113.3397	3075.0548
0.0135	0.9706	115.6412	2301.4907
0.0145	1.0871	117.3096	1668.4287
0.0155	1.2050	118.4537	1144.1245
0.0165	1.3238	119.1872	733.4403
0.0175	1.4432	119.6145	427.3088
0.0185	1.5629	119.8171	202.6146
0.0195	1.6827	119.8816	64.4622
0.0205	1.8026	119.8852	3.6535

Table D-X. (Cont'd) Predicted Translation Parameters - Standing  
at Entrance - 20% Open, 10.9 psi

TWO-ROOM MODEL-V/A=20.83FT

SHOT 24-75-172, 10.9PSI

TIME-SEC	DISTANCE-FT	VELOCITY-FT/SEC	ACCEL.-FT/SEC/SEC
0.0020	0.0245	24.5484	12274.1954
0.0040	0.0979	48.8351	12143.3579
0.0060	0.2194	72.6124	11888.6502
0.0080	0.3877	95.6947	11541.1344
0.0090	0.4889	106.7074	11012.7194
0.0100	0.6005	116.5708	9863.4359
0.0110	0.7215	125.3588	8787.9990
0.0120	0.8507	133.1464	7787.5925
0.0130	0.9873	139.9968	6850.3464
0.0140	1.1303	145.9786	5981.8208
0.0150	1.2789	151.1697	5191.1126
0.0170	1.5901	160.1018	4466.0270
0.0190	1.9168	166.5178	3208.0123
0.0210	2.2542	170.9226	2202.4215
0.0230	2.5989	173.7522	1414.7833
0.0250	2.9481	175.4183	833.0388
0.0290	3.6531	177.0873	417.2467
0.0310	4.0073	177.1292	20.9668
0.0330	4.3616	177.1469	8.8519



APPENDIX E

PREDICTED TRANSLATION PARAMETERS FOR FULL SIZE SHELTERS

1870  
1871  
1872  
1873  
1874  
1875  
1876  
1877  
1878  
1879  
1880  
1881  
1882  
1883  
1884  
1885  
1886  
1887  
1888  
1889  
1890  
1891  
1892  
1893  
1894  
1895  
1896  
1897  
1898  
1899  
1900

Table E-I. Predicted Translation Parameters - Prone at Entrance - 49% Open, 1-MT, 3 psi

TWO-ROOM SHELTER-V/A=61.5FT

1-MT, 3PSI

TIME-SEC	DISTANCE-FT	VELOCITY-FT/SEC	ACCEL.-FT/SEC/SEC
0.0100	0.0043	0.8529	85.2919
0.0200	0.0159	1.4748	62.1832
0.0300	0.0328	1.9028	42.8066
0.0400	0.0532	2.1755	27.2642
0.0500	0.0757	2.3281	15.2648
0.0600	0.0993	2.3937	6.5544
0.0700	0.1233	2.4027	0.9033

TWO-ROOM SHELTER-V/A=102.6FT

1-MT, 3PSI

TIME-SEC	DISTANCE-FT	VELOCITY-FT/SEC	ACCEL.-FT/SEC/SEC
0.0100	0.0043	0.8529	85.2919
0.0200	0.0163	1.5617	70.8787
0.0300	0.0348	2.1404	57.8660
0.0400	0.0586	2.6028	46.2439
0.0500	0.0864	2.9632	36.0350
0.0600	0.1174	3.2351	27.1957
0.0700	0.1507	3.4319	19.6832
0.0800	0.1857	3.5659	13.3911
0.0900	0.2218	3.6483	8.2454
0.1000	0.2585	3.6904	4.2111

Table E-II. Predicted Translation Parameters - Prone at Entrance - 49% Open, 1-MT, 10 psi

TWO-ROOM SHELTER-V/A=61.5FT

1-MT, 10PSI

TIME-SEC	DISTANCE-FT	VELOCITY-FT/SEC	ACCEL.-FT/SEC/SEC
0.0100	0.0117	2.3397	233.9653
0.0200	0.0474	4.7992	245.9563
0.0300	0.1081	7.3392	253.9989
0.0400	0.1914	9.3157	197.6504
0.0500	0.2917	10.7427	142.7039
0.0600	0.4039	11.7020	95.9255
0.0700	0.5238	12.2872	58.5233

TWO-ROOM SHELTER-V/A=102.6FT

1-MT, 10PSI

TIME-SEC	DISTANCE-FT	VELOCITY-FT/SEC	ACCEL.-FT/SEC/SEC
0.0100	0.0117	2.3397	233.9653
0.0200	0.0471	4.7474	240.7793
0.0300	0.1069	7.2086	246.1186
0.0400	0.1915	9.7057	249.7061
0.0500	0.2996	11.9258	222.0121
0.0600	0.4282	13.7817	185.5919
0.0700	0.5736	15.2974	151.5699
0.0800	0.7326	16.5044	120.6953
0.0900	0.9023	17.4373	93.2946
0.1000	1.0801	18.1331	69.5807
0.1100	1.2640	18.6275	49.4347
0.1200	1.4519	18.9547	32.7178
0.1300	1.6424	19.1470	19.2309

Table E-III. Predicted Translation Parameters - Prone at Entrance - 20% Open, 1-MT, 3 psi

TWO-ROOM SHELTER-V/A=150FT

1-MT, 3PSI

TIME-SEC	DISTANCE-FT	VELOCITY-FT/SEC	ACCEL.-FT/SEC/SEC
0.0100	0.0043	0.8529	85.2919
0.0200	0.0165	1.6037	75.0789
0.0300	0.0359	2.2592	65.5483
0.0400	0.0613	2.8258	56.6622
0.0500	0.0920	3.3110	48.5160
0.0600	0.1271	3.7217	41.0717
0.0700	0.1661	4.0646	34.2899
0.0800	0.2081	4.3462	28.1657
0.0900	0.2527	4.5732	22.6958
0.1000	0.2993	4.7516	17.8430
0.1100	0.3475	4.8873	13.5697
0.1200	0.3969	4.9857	9.8413
0.1300	0.4471	5.0526	6.6866

TWO-ROOM SHELTER-V/A=250FT

1-MT, 3PSI

TIME-SEC	DISTANCE-FT	VELOCITY-FT/SEC	ACCEL.-FT/SEC/SEC
0.0100	0.0043	0.8529	85.2919
0.0200	0.0167	1.6401	78.7172
0.0300	0.0368	2.3645	72.4414
0.0400	0.0637	3.0288	66.4295
0.0500	0.0970	3.6356	60.6797
0.0600	0.1362	4.1882	55.2575
0.0700	0.1805	4.6888	50.0608
0.0800	0.2297	5.1406	45.1860
0.0900	0.2831	5.5466	40.5981
0.1000	0.3404	5.9092	36.2624
0.1100	0.4011	6.2310	32.1771
0.1200	0.4648	6.5148	28.3750
0.1300	0.5312	6.7630	24.8196
0.1400	0.5999	6.9784	21.5415
0.1500	0.6706	7.1631	18.4745
0.1600	0.7431	7.3196	15.6514
0.1700	0.8169	7.4500	13.0351
0.1800	0.8919	7.5569	10.6918
0.1900	0.9679	7.6421	8.5233
0.2000	1.0447	7.7078	6.5623
0.2100	1.1220	7.7561	4.8375
0.2200	1.1997	7.7890	3.2896

Table E-IV. Predicted Translation Parameters - Prone at Entrance - 20% Open, 1-MT, 7 psi

TWO-ROOM SHELTER-V/A=150FT

1-MT, 7PSI

TIME-SEC	DISTANCE-FT	VELOCITY-FT/SEC	ACCEL.-FT/SEC/SEC
0.0100	0.0100	1.9954	199.5441
0.0200	0.0400	4.0082	201.2781
0.0300	0.0898	5.9530	194.4772
0.0400	0.1580	7.6960	174.2989
0.0500	0.2427	9.2432	154.7234
0.0600	0.3420	10.6030	135.9819
0.0700	0.4539	11.7860	118.2919
0.0800	0.5769	12.8038	101.7807
0.0900	0.7092	13.6690	86.5266
0.1000	0.8495	14.3946	72.5552
0.1100	0.9965	14.9934	59.8837
0.1200	1.1488	15.4787	48.5284
0.1300	1.3056	15.8624	38.3738
0.1400	1.4657	16.1569	29.4491
0.1500	1.6283	16.3734	21.6510
0.1600	1.7928	16.5231	14.9703

TWO-ROOM SHELTER-V/A=250FT

1-MT, 7PSI

TIME-SEC	DISTANCE-FT	VELOCITY-FT/SEC	ACCEL.-FT/SEC/SEC
0.0100	0.0100	1.9954	199.5441
0.0200	0.0399	3.9952	199.9783
0.0300	0.0899	5.9960	200.0792
0.0400	0.1595	7.9360	193.9980
0.0500	0.2479	9.7428	180.6791
0.0600	0.3537	11.4185	167.5679
0.0700	0.4757	12.9664	154.7953
0.0800	0.6125	14.3908	142.4347
0.0900	0.7629	15.6957	130.4971
0.1000	0.9258	16.8864	119.0633
0.1100	1.1001	17.9676	108.1189
0.1200	1.2846	18.9443	97.6699
0.1300	1.4785	19.8224	87.8179
0.1400	1.6806	20.6076	78.5138
0.1500	1.8902	21.3050	69.7414
0.1600	2.1063	21.9203	61.5362
0.1700	2.3282	22.4589	53.8507
0.1800	2.5551	22.9263	46.7418
0.1900	2.7864	23.3274	40.1108
0.2000	3.0214	23.6676	34.0227
0.2100	3.2595	23.9516	28.4031
0.2200	3.5001	24.1844	23.2790
0.2300	3.7429	24.3707	18.6233
0.2400	3.9873	24.5148	14.4177
0.2500	4.2330	24.6218	10.6929
0.2600	4.4796	24.6957	7.3977
0.2700	4.7268	24.7412	4.5496
0.2800	4.9743	24.7633	2.2052

Table E-V. Predicted Translation Parameters - Prone at Entrance - 20% Open, 1-MT, 10 psi

TWO-ROOM SHELTER-V/A=150FT

1-MT, 10PSI

TIME-SEC	DISTANCE-FT	VELOCITY-FT/SEC	ACCEL.-FT/SEC/SEC
0.0100	0.0117	2.3397	233.9653
0.0200	0.0470	4.7207	238.1056
0.0300	0.1063	7.1353	241.4637
0.0400	0.1898	9.5749	243.9506
0.0500	0.2979	12.0302	245.5365
0.0600	0.4299	14.3692	233.8936
0.0700	0.5839	16.4412	207.2025
0.0800	0.7574	18.2558	181.4659
0.0900	0.9478	19.8263	157.0491
0.1000	1.1528	21.1688	134.2423
0.1100	1.3701	22.3006	113.1805
0.1200	1.5978	23.2400	93.9410
0.1300	1.8341	24.0058	76.5798
0.1400	2.0772	24.6161	61.0386
0.1500	2.3257	25.0894	47.3225
0.1600	2.5784	25.4425	35.3158
0.1700	2.8340	25.6925	25.0000
0.1800	3.0918	25.8553	16.2751
0.1900	3.3508	25.9465	9.1207

Table E-V. (Cont'd) Predicted Translation Parameters -  
 Prone at Entrance - 20% Open, 1-MT, 10 psi

TWO-ROOM SHELTER-V/A=250FT

1-MT, 10PSI

TIME-SEC	DISTANCE-FT	VELOCITY-FT/SEC	ACCEL.-FT/SEC/SEC
0.0100	0.0117	2.3397	233.9653
0.0200	0.0469	4.6959	235.6233
0.0300	0.1057	7.0654	236.9539
0.0400	0.1882	9.4447	237.9285
0.0500	0.2946	11.8302	238.5520
0.0600	0.4248	14.2181	238.7853
0.0700	0.5790	16.6042	238.6091
0.0800	0.7569	18.9848	238.0626
0.0900	0.9578	21.1991	221.4282
0.1000	1.1800	23.2386	203.9543
0.1100	1.4217	25.1035	186.4915
0.1200	1.6813	26.8090	170.5503
0.1300	1.9571	28.3569	154.7846
0.1400	2.2477	29.7539	139.6975
0.1500	2.5515	31.0077	125.3885
0.1600	2.8671	32.1262	111.8481
0.1700	3.1934	33.1169	99.0672
0.1800	3.5289	33.9881	87.1152
0.1900	3.8726	34.7479	75.9797
0.2000	4.2233	35.4037	65.5878
0.2100	4.5802	35.9639	56.0220
0.2200	4.9422	36.4360	47.2098
0.2300	5.3085	36.8273	39.1292
0.2400	5.6783	37.1451	31.7739
0.2500	6.0511	37.3966	25.1486
0.2600	6.4260	37.5884	19.1827
0.2700	6.8026	37.7277	13.9346
0.2800	7.1803	37.8211	9.3381

Table E-VI. Predicted Translation Parameters - Standing  
at Entrance - 49% Open, 1-MT, 3 psi

TWO-ROOM SHELTER-V/A=61.5FT

1-MT, 3PSI

TIME-SEC	DISTANCE-FT	VELOCITY-FT/SEC	ACCEL.-FT/SEC/SEC
0.0100	0.0320	6.3969	639.6894
0.0200	0.1187	10.9452	454.8307
0.0300	0.2434	13.9885	304.3345
0.0400	0.3926	15.8605	187.1905
0.0500	0.5562	16.8583	99.7800
0.0600	0.7267	17.2487	39.0396
0.0700	0.8994	17.2819	3.3132

TWO-ROOM SHELTER-V/A=102.6FT

1-MT, 3PSI

TIME-SEC	DISTANCE-FT	VELOCITY-FT/SEC	ACCEL.-FT/SEC/SEC
0.0100	0.0320	6.3969	639.6894
0.0200	0.1219	11.5929	519.6036
0.0300	0.2586	15.7340	414.1032
0.0400	0.4320	18.9584	322.4446
0.0500	0.6338	21.3997	244.1335
0.0600	0.8567	23.1821	178.2358
0.0700	1.0947	24.4210	123.8923
0.0800	1.3430	25.2203	79.9271
0.0900	1.5974	25.6745	45.4163
0.1000	1.8552	25.8743	19.9842

Table E-VII. Predicted Translation Parameters - Standing  
at Entrance - 49% Open, 1-MT, 10 psi

TWO-ROOM SHELTER-V/A=61.5FT

1-MT, 10PSI

TIME-SEC	DISTANCE-FT	VELOCITY-FT/SEC	ACCEL.-FT/SEC/SEC
0.0100	0.0877	17.5474	1754.7399
0.0200	0.3521	35.3283	1778.0865
0.0300	0.7935	52.9466	1761.8350
0.0400	1.3873	65.8115	1286.4868
0.0500	2.0883	74.4010	858.9516
0.0600	2.8585	79.6218	522.0800
0.0700	3.6685	82.3774	275.5636

TWO-ROOM SHELTER-V/A=102.6FT

1-MT, 10PSI

TIME-SEC	DISTANCE-FT	VELOCITY-FT/SEC	ACCEL.-FT/SEC/SEC
0.0100	0.0877	17.5474	1754.7399
0.0200	0.3504	34.9809	1743.3542
0.0300	0.7860	52.1424	1716.1503
0.0400	1.3911	68.8716	1672.9153
0.0500	2.1503	82.9795	1410.7928
0.0600	3.0355	94.0623	1108.2737
0.0700	4.0183	102.4976	843.5371
0.0800	5.0743	108.6930	619.5347
0.0900	6.1829	113.0359	434.2933
0.1000	7.3276	115.8977	286.1830
0.1100	8.4952	117.6136	171.5897
0.1200	9.6757	118.4893	87.5688
0.1300	10.8621	118.8038	31.4442

Table E-VIII. Predicted Translation Parameters - Standing  
at Entrance - 20% Open, 1-MT, 3 psi

TWO-ROOM SHELTER-V/A=150FT

1-MT, 3PSI

TIME-SEC	DISTANCE-FT	VELOCITY-FT/SEC	ACCEL.-FT/SEC/SEC
0.0100	0.0320	6.3969	639.6894
0.0200	0.1235	11.9063	550.9442
0.0300	0.2661	16.6094	470.3037
0.0400	0.4520	20.5805	397.1095
0.0500	0.6744	23.8980	331.7549
0.0600	0.9271	26.6342	273.6195
0.0700	1.2045	28.8546	222.0410
0.0800	1.5019	30.6216	176.6952
0.0900	1.8150	31.9951	137.3496
0.1000	2.1401	33.0301	103.5057
0.1100	2.4742	33.7767	74.6619
0.1200	2.8144	34.2816	50.4836
0.1300	3.1588	34.5915	30.9949

TWO-ROOM SHELTER-V/A=250FT

1-MT, 3PSI

TIME-SEC	DISTANCE-FT	VELOCITY-FT/SEC	ACCEL.-FT/SEC/SEC
0.0100	0.0320	6.3969	639.6894
0.0200	0.1249	12.1780	578.1138
0.0300	0.2727	17.3864	520.8354
0.0400	0.4699	22.0604	467.3982
0.0500	0.7114	26.2365	417.6119
0.0600	0.9924	29.9550	371.8561
0.0700	1.3084	33.2467	329.1653
0.0800	1.6553	36.1474	290.0703
0.0900	2.0295	38.6891	254.1696
0.1000	2.4275	40.9000	221.0907
0.1100	2.8460	42.8071	190.7066
0.1200	3.2822	44.4392	163.2078
0.1300	3.7335	45.8207	138.1580
0.1400	4.1975	46.9773	115.6613
0.1500	4.6721	47.9295	95.2107
0.1600	5.1552	48.6995	77.0067
0.1700	5.6452	49.3059	60.6355
0.1800	6.1406	49.7714	46.5519
0.1900	6.6400	50.1122	34.0820
0.2000	7.1423	50.3466	23.4405
0.2100	7.6465	50.4936	14.6965
0.2200	8.1518	50.5702	7.6656

Table E-IX. Predicted Translation Parameters - Standing  
at Entrance - 20% Open, 1-MT, 7 psi

TWO-ROOM SHELTER-V/A=150FT

1-MT, 7PSI

TIME-SEC	DISTANCE-FT	VELOCITY-FT/SEC	ACCEL.-FT/SEC/SEC
0.0100	0.0748	14.9658	1496.5804
0.0200	0.2976	29.5883	1462.2509
0.0300	0.6617	43.2400	1365.1722
0.0400	1.1530	55.0036	1176.3565
0.0500	1.7531	65.0243	1002.0652
0.0600	2.4455	73.4563	843.2077
0.0700	3.2151	80.4572	700.0849
0.0800	4.0483	86.1852	572.8058
0.0900	4.9332	90.7911	460.5905
0.1000	5.8592	94.4190	362.8756
0.1100	6.8174	97.2081	278.8215
0.1200	7.7998	99.2846	207.6473
0.1300	8.8001	100.7623	147.7675
0.1400	9.8126	101.7527	99.0412
0.1500	10.8332	102.3541	60.1382
0.1600	11.8582	102.5625	30.8461

Table E-IX. (Cont'd) Predicted Translation Parameters - Standing  
at Entrance - 20% Open, 1-MT, 7 psi

TWO-ROOM SHELTER-V/A=250FT

1-MT, 7PSI

TIME-SEC	DISTANCE-FT	VELOCITY-FT/SEC	ACCEL.-FT/SEC/SEC
0.0100	0.0748	14.9658	1406.5804
0.0200	0.2972	29.5024	1453.6575
0.0300	0.6626	43.5927	1409.0272
0.0400	1.1646	56.8016	1320.8913
0.0500	1.7919	68.6606	1185.8991
0.0600	2.5315	79.2530	1059.2480
0.0700	3.3711	88.6666	941.3557
0.0800	4.2994	96.9922	832.5643
0.0900	5.3059	104.3090	731.6747
0.1000	6.3810	110.7035	639.4552
0.1100	7.5157	116.2528	554.9226
0.1200	8.7022	121.0328	478.0036
0.1300	9.9329	125.1143	408.1533
0.1400	11.2013	128.5677	345.3358
0.1500	12.5014	131.4549	288.7251
0.1600	13.8279	133.8394	238.4484
0.1700	15.1760	135.7756	193.6175
0.1800	16.5414	137.3182	154.2557
0.1900	17.9206	138.5144	119.6213
0.2000	19.3102	139.4144	90.0002
0.2100	20.7076	140.0610	64.6616
0.2200	22.1104	140.4970	43.6061
0.2300	23.5167	140.7644	26.7354
0.2400	24.9250	140.9015	13.7086
0.2500	26.3343	140.9521	5.0660
0.2600	27.7439	140.9575	0.5330
0.2700	29.1535	140.9654	0.7931
0.2800	30.5635	141.0372	7.1838

Table E-X. Predicted Translation Parameters - Standing  
at Entrance - 20% Open, 1-MT, 10 psi

TWO-ROOM SHELTER-V/A=150FT

1-MT, 10PSI

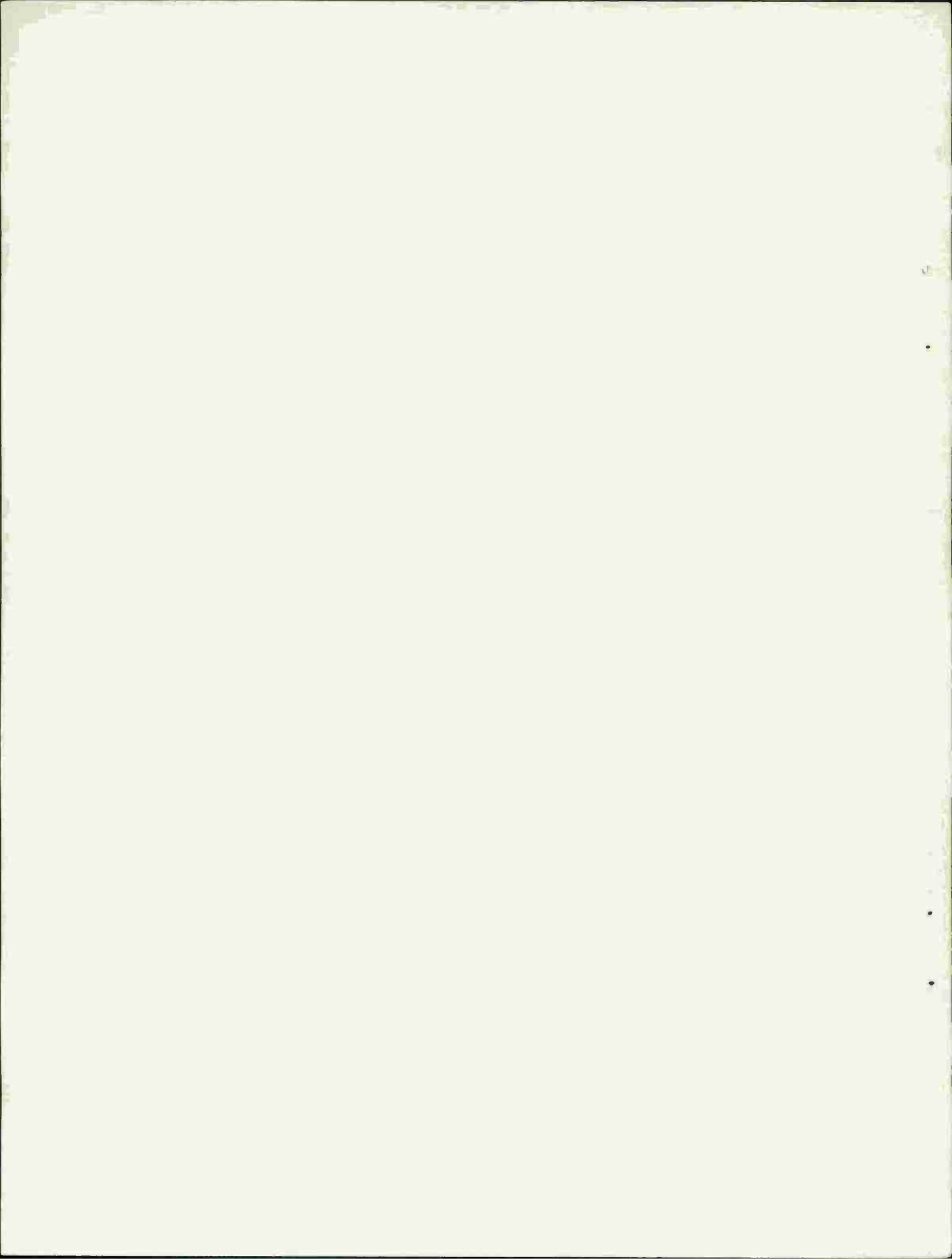
TIME-SEC	DISTANCE-FT	VELOCITY-FT/SEC	ACCEL.-FT/SEC/SEC
0.0100	0.0877	17.5474	1754.7399
0.0200	0.3495	34.7998	1725.2355
0.0300	0.7819	51.6781	1687.8301
0.0400	1.3808	68.1064	1642.8372
0.0500	2.1414	84.0126	1590.6195
0.0600	3.0539	98.4996	1448.6944
0.0700	4.0997	110.6425	1214.2909
0.0800	5.2562	120.6607	1001.8244
0.0900	6.5034	128.7866	812.5871
0.1000	7.8236	135.2572	647.0625
0.1100	9.2013	140.2873	503.0077
0.1200	10.6232	144.0914	380.4074
0.1300	12.0780	146.8669	277.5489
0.1400	13.5563	148.7939	192.7009
0.1500	15.0505	150.0407	124.6814
0.1600	16.5545	150.7605	71.9845
0.1700	18.0638	151.0992	33.8652
0.1800	19.5753	151.1964	9.7190
0.1900	21.0873	151.1973	0.0910

Table E-X. (Cont'd) Predicted Translation Parameters - Standing  
at Entrance - 20% Open, 1-MT, 10 psi

TWO-ROOM SHELTER-V/A=250FT

1-MT, 10PSI

TIME-SEC	DISTANCE-FT	VELOCITY-FT/SEC	ACCEL.-FT/SEC/SEC
0.0100	0.0877	17.5474	1754.7399
0.0200	0.3486	34.6294	1708.2045
0.0300	0.7779	51.2263	1659.6894
0.0400	1.3706	67.3197	1609.3344
0.0500	2.1217	82.8947	1557.5053
0.0600	3.0258	97.9323	1503.7550
0.0700	4.0776	112.4184	1448.6115
0.0800	5.2714	126.3448	1392.6421
0.0900	6.5966	138.6930	1234.8204
0.1000	8.0376	149.4995	1080.6469
0.1100	9.5786	158.7144	921.4918
0.1200	11.2063	166.8240	811.0535
0.1300	12.9003	173.7617	693.6719
0.1400	14.6763	179.6407	587.9003
0.1500	16.4973	184.5690	492.9188
0.1600	18.3634	188.6494	407.9553
0.1700	20.2665	191.9727	332.3274
0.1800	22.1996	194.5346	266.1953
0.1900	24.1564	196.7220	208.8217
0.2000	26.1315	198.3098	158.6926
0.2100	28.1204	199.4741	116.4285
0.2200	30.1192	200.2866	81.2556
0.2300	32.1247	200.8121	52.5503
0.2400	34.1344	201.1134	30.1270
0.2500	36.1462	201.2533	13.9870
0.2600	38.1589	201.2917	3.8470
0.2700	40.1718	201.2920	0.0235
0.2800	42.1849	201.3218	2.9819



DISTRIBUTION LIST

<u>No. of Copies</u>	<u>Organization</u>	<u>No. of Copies</u>	<u>Organization</u>
12	Commander Defense Documentation Center ATTN: DDC-TCA Cameron Station Alexandria, VA 22314	1	Commander US Army Missile Command ATTN: DRSMI-R Redstone Arsenal, AL 35809
1	Director Institute for Defense Analysis ATTN: Dr. A. Sachs 400 Army-Navy Drive Arlington, VA 22202	1	Commander US Army Tank Automotive Development Command ATTN: DRDTA-RWL Warren, MI 48090
2	Director Defense Nuclear Agency ATTN: STSP (SPLN) Mr. J. Kelso STAP (APTL), Lib Washington, DC 20305	2	Commander US Army Mobility Equipment Research & Development Command ATTN: Tech Docu Cen, Bldg 315 DRSME-RZT Fort Belvoir, VA 22060
1	Commander US Army Materiel Development and Readiness Command ATTN: DRCDMA-ST 5001 Eisenhower Avenue Alexandria, VA 22333	1	Commander US Army Armament Command Rock Island, IL 61202
1	Commander US Army Aviation Systems Command ATTN: DRSAV-E 12th and Spruce Streets St. Louis, MO 63166	1	Commander US Army Harry Diamond Labs ATTN: DRXDO-TI 2800 Powder Mill Road Adelphi, MD 20783
1	Director US Army Air Mobility Research and Development Laboratory Ames Research Center Moffett Field, CA 94035	1	Director US Army TRADOC Systems Analysis Activity ATTN: ATAA-SA White Sands Missile Range NM 88002
1	Commander US Army Electronics Command ATTN: DRSEL-RD Fort Monmouth, NJ 07703	1	Commander US Army Materials and Mechanics Research Center ATTN: DRXMR-ATL Watertown, MA 02172
		1	Commander US Army Natick Research and Development Command ATTN: Dr. D. Sieling, DRXRE Natick, MA 01762

DISTRIBUTION LIST

<u>No. of Copies</u>	<u>Organization</u>	<u>No. of Copies</u>	<u>Organization</u>
50	Defense Civil Preparedness Agency Research and Engineering ATTN: Admin Office Washington, DC 20301	1	Director Office of Administration Program Planning and Control ATTN: Mr. Bert Greenglass Dept of Housing & Urban Dvlp Washington, DC 20410
3	Defense Civil Preparedness Agency ATTN: Rsch Dir, Mr. Sisson Tech Svc, Dir Mr. J. Roembke Mr. H. Wakabayashi Washington, DC 20310	1	Office of the Chief of Engineers ATTN: Mr. Roy T. Spurlock Department of the Army Washington, DC 20314
1	Director DARCOM Field Safety Activity ATTN: DRXOS-ES Charlestown, IN 47111	1	Chief of Engineers ATTN: ENGME-RD Department of the Army Washington, DC 20314
1	Deputy Assistant Secretary of the Army (R&D) ATTN: Asst for Rsch Washington, DC 20310	3	Commander US Naval Air Systems Command ATTN: AIR-604 Washington, DC 20360
1	HQDA (DAEN, ENGME-RD) Washington, DC 20310	1	Commander US Naval Facilities Eng Command ATTN: R&D Code 0322C Washington, DC 20390
2	Commander US Army Engineer Waterways Experiment Station ATTN: Docu Lib Nucl Wpns Eff Br P.O. Box 631 Vicksburg, MS 39180	3	Commander US Naval Ordnance Systems Command ATTN: ORD-0632 ORD-035 ORD-5524 Washington, DC 20390
1	Advisory Committee on Civil Defense National Academy of Sciences 2101 Constitution Avenue, NW Washington, DC 20418	3	Commander US Naval Supply Systems Command ATTN: Code 0652 Washington, DC 20390
		1	Chief of Naval Personnel ATTN: Code Pers M12 Department of the Navy Washington, DC 20360

DISTRIBUTION LIST

<u>No. of Copies</u>	<u>Organization</u>	<u>No. of Copies</u>	<u>Organization</u>
1	Chief of Naval Research Department of the Navy Washington, DC 20360	1	Agbabian Associates ATTN: Mr. Curtil Lang 250 North Nash Street El Segundo, CA 90245
1	Commander US Naval Civil Engineering Lab ATTN: Library Port Hueneme, CA 93401	1	Agbabian-Jacobsen Associates 8943 South Sepulveda Boulevard Los Angeles, CA 90045
1	AFWL (SUL) Kirtland AFB, NM 87117	1	Chairman, Coordinating Committee on Civil Defense American Society of Civil Engineers ATTN: Mr. A. Caster 2864 McFarlan Park Drive Cincinnati, OH 45211
1	AFWL (Civil Eng Div) Kirtland AFB, NM 87117		
1	Civil Engineering Center AF/PRECE Wright-Patterson AFB, OH 45433	3	Bell Telephone Laboratories ATTN: Mr. E. Witt Mr. R. Mayo Mr. J. Foss Whippany Road Whippany, NJ 07981
2	Headquarters US Energy Research and Development Administration Dept of Military Applications Division of Biology and Medicine ATTN: Civil Eff Br Mr. L. J. Deal Dr. Rudolf J. Engelmann Washington, DC 20545	1	The Dikewood Corporation University Research Park 1009 Bradbury Drive, SE Albuquerque, NM 87106
1	Oak Ridge National Laboratory Civil Defense Research Project ATTN: Librarian P.O. Box X Oak Ridge, TN 37830	1	Eberle Smith Associates, Inc. ATTN: Mr. Lyndon Welch 950 West Fort Street Detroit, MI 48226
1	President National Academy of Sciences National Research Council Advisory Committee on Civil Defense ATTN: Mr. R. Park 2101 Constitution Avenue, NW Washington, DC 20418	1	Environmental Sciences Associates ATTN: Mr. Paul Zigman 770 Airport Road Burlingame, CA 94010
		1	General American Transportation Corporation General American Research Div 7449 North Natchez Avenue Niles, IL 60648

DISTRIBUTION LIST

<u>No. of Copies</u>	<u>Organization</u>	<u>No. of Copies</u>	<u>Organization</u>
1	President-Director Lovelace Foundation ATTN: Dr. S. White 5200 Gibson Boulevard, SE Albuquerque, NM 87108	1	Pennsylvania State University ATTN: Prof R. Kummer 101 Eng A University Park, PA 16802
2	The Rand Corporation ATTN: Dr. H. Brode Document Library 1700 Main Street Santa Monica, CA 90401	1	Purdue University Purdue Research Foundation School of Civil Engineering ATTN: Mr. M. Scott Civil Engineering Building Lafayette, IN 47907
2	Sandia Laboratories ATTN: Dir 5412, L. Vortman Dept 5230, Dr. Mehl P.O. Box 5800 Albuquerque, NM 87115	1	Purdue University Nuclear Engineering Department ATTN: Prof Robert Baily Duncan Annex Lafayette, IN 47907
1	Scientific Services, Inc. ATTN: Mr. Charles Wilton 830 Charter Street Redwood City, CA 94063	2	Research Triangle Institute ATTN: Edward L. Hill Milton D. Wright P.O. Box 12194 Research Triangle Park NC 27709
2	URS Research Company ATTN: Library William H. Van Horn 155 Bovet Road San Mateo, CA 94402	1	San Jose State College Department of Civil Engineering ATTN: Dr. R. Spicker San Jose, CA 95114
1	George Washington University School of Engineering and Applied Science Nuclear Defense Design Center ATTN: Prof R. Fox Washington, DC 20006	3	Stanford Research Institute ATTN: Dr. S. Martin Dr. H. Murphy Mr. C. Wiehle 333 Ravenswood Avenue Menlo Park, CA 94025
2	IIT Research Institute ATTN: Mr. A. Longinow Mr. T. Waterman 10 West 35th Street Chicago, IL 60616	1	University of Arizona OCD Professional Advisory Service ATTN: Miss N. Barberii Tucson, AZ 85721

DISTRIBUTION LIST

<u>No. of Copies</u>	<u>Organization</u>
1	University of Colorado School of Architecture ATTN: Prof G. Vetter Boulder, CO 80302
1	University of Florida Department of Mechanical Engineering ATTN: Prof J. Samuel Gainesville, FL 32601
1	University of Illinois ATTN: Dr. W. Hall 111 Talbot Laboratory Urbana, IL 61803
1	University of Massachusetts School of Engineering ATTN: Dr. M. P. White Amherst, MA 01002
1	University of Washington Department of Civil Engineering ATTN: Prof W. Miller 307 More Hall Seattle, WA 98105
1	Worcester Polytechnic Institute Department of Civil Engineering ATTN: Prof C. Koontz Worcester, MA 01609

Aberdeen Proving Ground

Marine Corps Ln Ofc  
Dir, USAMSAA

