

AD-A031 531

MARTIN CO BALTIMORE MD ELECTRONIC SYSTEMS AND PRODU--ETC F/G 17/7  
SUBMERGED SUBMARINE NAVIGATION AID STUDY.(U)  
MAR 62

UNCLASSIFIED

ER-12316

NOBSR-85577

NL

1 of 3  
AD  
A031531

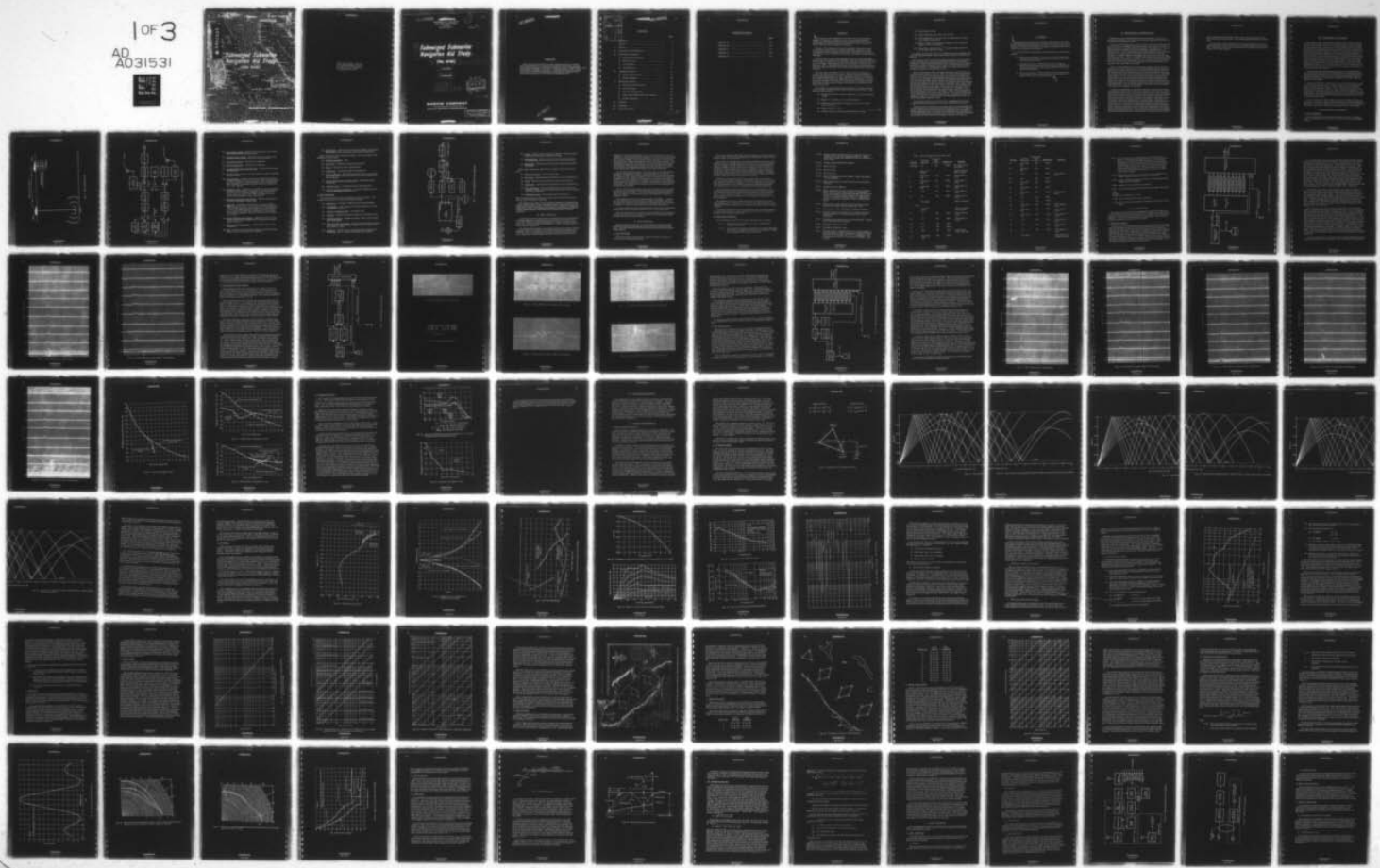

AD A 031531

This part is very shoal with dry sand bars

MOST Project a

UNCLASSIFIED

# Submerged Submarine Navigation Aid Study

## (FINAL REPORT)

TO ZONE OF THE OCEAN

NOV 2 1976

689A  
1 copy  
rec'd for 689A

NOBSR 85577  
new

Narrow ridges of sand with deep water between 3  
620413-0250

MARTIN COMPANY

UNCLASSIFIED



CONFIDENTIAL

NOTICE: This document contains information affecting the National Defense of the United States within the meaning of the Espionage Laws, Title 18, U.S.C., Sections 793 and 794. Its transmission or the revelation of its contents in any manner to an Unauthorized Person is prohibited by Law.

CONFIDENTIAL

~~UNCLASSIFIED~~

~~XXXXXXXXXX~~  
DOWNGRADED AT 3-YEAR INTER-  
VALS; DECLASSIFIED AFTER  
12 YEARS  
DOD DIR 5200.10

1

FC

Copy No. 18

6 Submerged Submarine  
Navigation Aid Study.

9 (FINAL REPORT) Jul 61 - 28 Feb 62

14 ER-12316

11 MARCH 1962

12 223 p.

15 NObsr - 85577

DDC  
RECEIVED  
NOV 2 1976  
REGISTERED  
A

620413-0250

**MARTIN COMPANY**  
Electronic Systems and Products Division  
**MARTIN MARIETTA CORPORATION**

DISTRIBUTION STATEMENT A  
Approved for public release;  
Distribution Unlimited

219120  
bpg

~~XXXXXXXXXX~~

UNCLASSIFIED

~~CONFIDENTIAL~~

UNCLASSIFIED

FOREWORD

This report is submitted to the Navy Department Bureau of Ships Electronics Division by the Electronic Systems and Products Division of the Martin Company in fulfillment of Contract Number NObsr 85577, Index Number SF099031, Task 1461. Contained herein are the methods and results of the Submerged Submarine Navigation Aid Study, which covered the period from 1 July 1961 to 28 February 1962.

NEW

UNCLASSIFIED

~~CONFIDENTIAL~~  
ER 12316

~~CONFIDENTIAL~~ UNCLASSIFIED

RECESSION LOG	
RTG	White Section <input checked="" type="checkbox"/>
DDC	Diff Section <input type="checkbox"/>
DRAG/DRONE	<input type="checkbox"/>
JUSTIFICATION	
BY	
DISTRIBUTION / AVAILABILITY CODE	
EXT	APPROV. NO. OF PAGES
A	

*Letter on file*

CONTENTS

	Page
Foreword . . . . .	ii
Abstract . . . . .	v
I. Purpose . . . . .	1
II. Preliminary Considerations . . . . .	3
III. Experimental Program . . . . .	5
A. Experimental Equipment . . . . .	5
B. Ship's Services . . . . .	11
C. Test Program . . . . .	12
D. Data Reduction . . . . .	17
IV. Configuration Study . . . . .	41
A. System Requirements . . . . .	41
B. Block Diagrams . . . . .	83
V. Operations Analysis . . . . .	95
A. Operational Requirements . . . . .	95
B. Area Coverage . . . . .	99
C. Accuracy Determination . . . . .	104
D. Power Supply Method and Cost Analysis . . . . .	123
E. Growth Capability . . . . .	129
VI. Schedule . . . . .	131
VII. Personnel . . . . .	133
VIII. Recommendations . . . . .	135

620413-0250

~~CONFIDENTIAL~~  
ER 12316

UNCLASSIFIED

CONTENTS (continued)

	Page
Appendix A . . . . .	A-1
Appendix B . . . . .	B-1
Appendix C . . . . .	C-1
Appendix D . . . . .	D-1
Appendix E . . . . .	E-1

ABSTRACT

The purpose of this program was to determine the specifications design of a submarine navigation aid for the operational range of AUTEK, by studying and optimizing all the factors involved. The desired system is based on accuracy of 50 yards or better at depths of 150 to 1500 feet, and at speeds up to 30 knots.

Initially, it was determined that the navigation method to be used was acoustic by nature, due to existing submarine equipment and the limitations of other techniques under water. From this, two acoustic-type systems can be considered: direct path coverage or bottom bounce coverage.

The first type can be readily designed to give the required system performance with presently available data. Because only about 5000 feet of water depth is available, the coverage of this type of system is limited to a 5-mi range. This required 120 to 150 stations to cover the complete area with the attendant installation, power supply, maintenance and location problems that arise as a result of the large number of stations involved.

The only other alternative is to use bottom bounce techniques to increase the individual station range. This decreases the number of stations required to about 15 to 20. Enough data was not available, as far as signal degradation with range and bottom bounces is concerned, to be able to comprehensively study this system and compare it with a direct-type system. To resolve this problem and to acquire the necessary data, an experimental program was planned and conducted in the Exuma Sound area.

The analysis of the data from this program has provided sufficient input to allow a complete determination of system parameters. These system parameters are:

- (1) Navigation method--acoustic ranges only, with synchronized clocks.
- (2) Range--6.5 mi direct, 15 mi with one bounce.
- (3) Frequency of operation--two bands; 1.8 kc to 2.0 kc and 2.2 kc to 2.4 kc.
- (4) Range resolution--25 ft.
- (5) Coding--FM pulse, 200 cps linear frequency sweep.

620418-0250

CONFIDENTIAL

- (6) Pulse length--50 ms.
- (7) Pulse repetition rate--once every 30 sec.
- (8) Processing filters--20 cps wide, 10 required per channel (two channels necessary).
- (9) Station coding--four types, ascending and descending FM pulses in each of two bands.
- (10) Transducer requirements--1-kw peak acoustic power at 2.1 kc, with a Q of 4 or less.

In addition to the above items, the configuration of a navigation computer was determined that would automatically compute the submarine position.

An accuracy model was derived using pessimistic accuracy values. Using this model, several beacon placement schemes were studied. From this, it was determined that the optimum placement of 15 beacons would give a usable coverage of 2809 sq mi, with an average accuracy of better than 40 yd. This amounts to 84% of the total area of Exuma Sound area between the 100-fathom curves.

The cost analysis has been completed and shows that there are two acceptable power supply systems. Both use diesel powered generators on shore with cable to the deep beacons. In one case, the beacon consists only of a projector and matching network which are driven from a shore driver through a cable capable of handling the high peak powers. The beacons in the other system consist of a projector and matching network, individual deep driver and storage batteries which are charged through an inexpensive cable from shore. The first case results in the most reliable system, with a total cost of about 2.7 million dollars for the complete Exuma Sound range (15 beacons, 84% coverage). The latter system, while perhaps not as reliable, has a total cost of about 1.9 million dollars for the same coverage. Neither of these figures include maintenance costs which may be higher in the second system and which could decrease the gap between the two. Development cost of the shipboard computer is also included in the above figures, but the cost of the operational computer is not.

The final end product of the study is the "Specification for a Submerged Submarine Navigation Aid" which is included as Appendix C.

Feasibility has been proven in the study, and it is recommended that the next logical step, implementation of a small portion of the range, be taken to determine and demonstrate the capabilities of the navigation system designed herein. This would be accomplished by installation of the northern three beacons and their associated shore station, along with location and accuracy tests and navigation computer development.

CONFIDENTIAL  
ER 12316

I. PURPOSE

The purpose of this study was to derive a specification for a Submerged Submarine Navigation Aid for the approximately 40 by 100 mi Exuma Sound Operational Range of AUTEK. The Navaid is to have an accuracy of 50 yd for a submarine traveling at a depth between 150 to 1500 ft and at a speed of up to 30 kn.

To meet the above requirements, the following items were accomplished.

- (1) Experimental program. Tests on site and attendant data reduction to determine parameters necessary to the study but with unknown values.
- (2) Configuration study. Determination of the navigation geometry, system parameters and computer configuration using available data as well as data derived from the experimental program.
- (3) Operations analysis. Determination of beacon placement, power supply method and growth potential for optimum system accuracy, cost and reliability.

## II. PRELIMINARY CONSIDERATIONS

Several factors were determined early in the study, such as the transmission method, choice between continuous and pulse transmission, and applicable propagation mode.

Since the operational range covered a fairly large area (approximately 40 by 100 mi), a reasonably long range system was required in order to keep the number of installations to a minimum. For instance, if a 15-mi range system is feasible, only about 20 different installations are required, but for a 5-mi range system about 160 installations are required, and for a 1-mi range system about 4000 installations are required. Therefore, it was extremely advantageous to use a system with as long a range as possible. Of all the possible underwater transmission methods (RF, magnetic, electrostatic, acoustic, etc.), only the acoustic method was known to reliably reach the ranges (5 to 15 mi) required for the Navigation Aid. Therefore, acoustic transmission was the only method considered in the remainder of the study.

Since the Navigation Aid will use acoustic signals, there is the possibility that mutual interference will exist between the Navaid and existing and future sonar systems used with ships, submarines and aircraft. To minimize this and, therefore, prevent continuous acoustic cluttering of the operational area, pulse transmission is preferred over continuous transmission. Pulse transmission lends itself easily to nonambiguous range indication, which is a necessity since ambiguous navigation systems have proven themselves unsatisfactory in many cases of use for above water systems. Continuous transmission can be coded to give unambiguous range, but the coding techniques required increase the equipment complexity. For the above reasons, only pulse-type transmission was used in the remainder of the study.

Acoustic transmission was selected, but there remained the choice of propagation mode. There were three possible modes: direct, surface channel and bottom bounce. The surface channel mode was eliminated immediately because it does not exist all the time and varies considerably with the time of the year, sea state and local weather conditions. The direct path could be used but is limited to a range of 5 mi, which is sufficient but results in a large number of installations. Enough data is available to show the feasibility of this method and to accurately predict its performance. The bottom bounce mode (using one bounce) gives a range of 15 mi, resulting in a considerably smaller number of installations. Sufficient information was not available regarding bottom losses and pulse degradation to determine system feasibility and to reasonably predict system performance. For this reason the experimental program described in Chapter III was embarked upon to acquire sufficient data to

CONFIDENTIAL

permit evaluation of the bottom bounce mode versus the direct mode and a selection between the two. The comparison and selection is made later.

At this point, it was determined that the Submerged Submarine Navigation Aid would utilize pulsed acoustic signals using either the direct path propagation mode (5-mi range system) or the single bottom bounce mode (15-mi range system).

### III. EXPERIMENTAL PROGRAM

The purpose of the experimental program was to obtain additional data for an intelligent study of a long range navigation system versus a short range system. Previous data was available to allow a design and study for the short range case. The necessary and desired information from an experimental setup is threefold. First, the timing accuracy of the received pulse as a function of range (and therefore number of bottom bounces), signal-to-noise ratio and pulse modulation characteristics must be determined, since the navigation system cannot be any more accurate than this timing. Second, if sufficient timing accuracy is achieved, it must be determined whether the average velocity of sound is constant or predictable enough to determine range with the desired accuracy. This includes whether or not the desired signal can be separated when more than one is received due to other propagation modes. Last, the bottom bounce loss as a function of frequency and incidence angle is required to determine the acoustical and electrical power requirements.

The only difficulty anticipated was acquisition of timing stability data because the tests were to be conducted once during the year and only short term variations could be measured. This problem was not considered serious, however, because bathythermographic data for the whole year were available and a computer study of the long term effects could be made.

The desired data was acquired by a two-ship operation in the area. The intended procedure was to transmit AM, FM, and pseudorandom signals, primarily in the range of 500 to 1500 cps and at different source levels from Ship 1 (Fig. 1). Ship 2 was then to make tape recordings of the signals received at various depths and distances. The tapes were to then be played back and analyzed at the Martin Company in Baltimore. Accurate navigational position was desirable in all cases for both ships but mandatory only during the acquisition of data of the second type listed above.

In order to meet the above objectives, several steps had to be implemented. These were the design and fabrication of the experimental equipment, procuring of ships' services, experimental tests, and finally reduction of the data. A detailed discussion of these items follows.

#### A. EXPERIMENTAL EQUIPMENT

##### 1. Ship 1 Equipment

A block diagram of the equipment required on Ship 1 is shown in Fig. 2. The function and source of each item are discussed on pages 8 and 9.

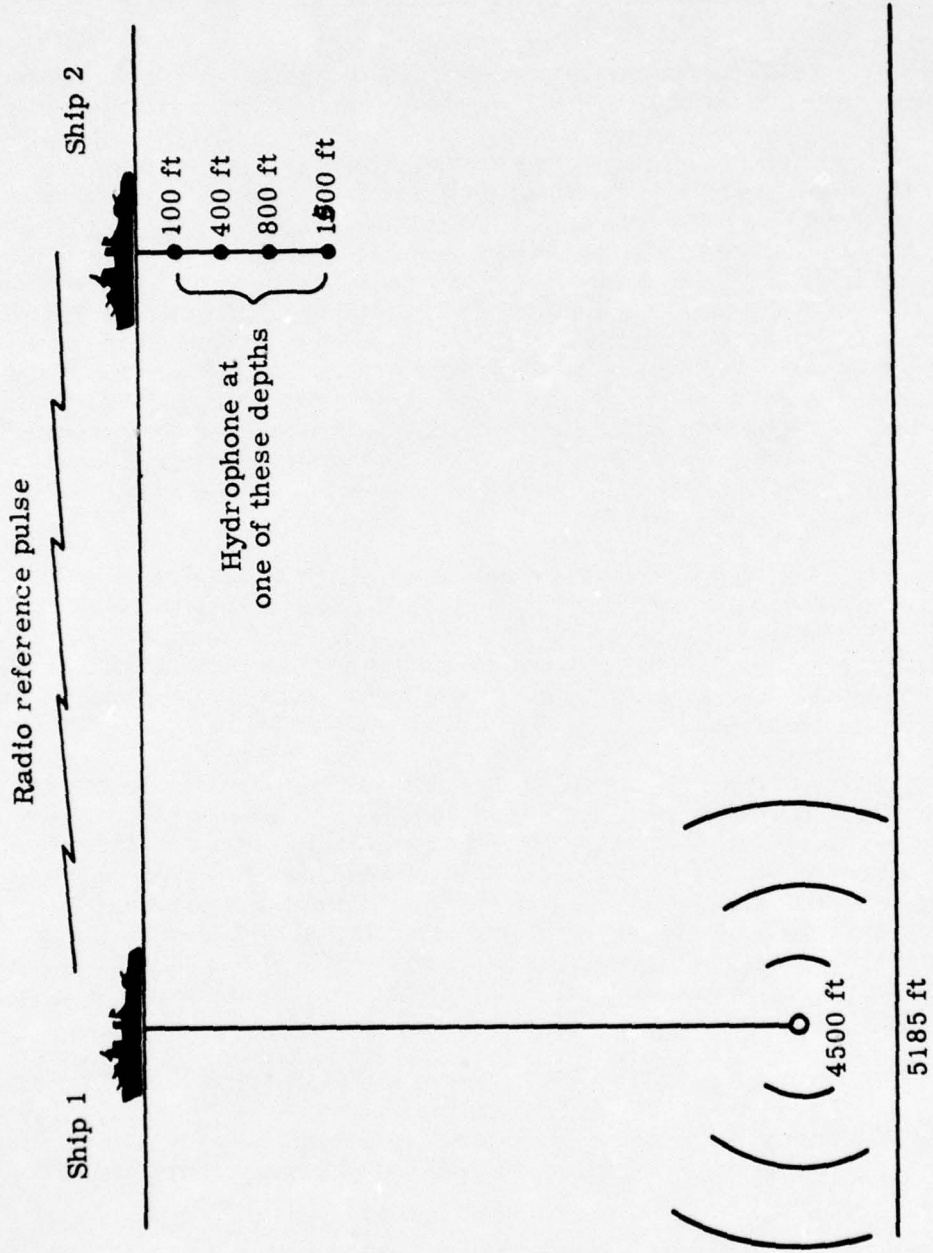

Fig. 1. Experimental Setup

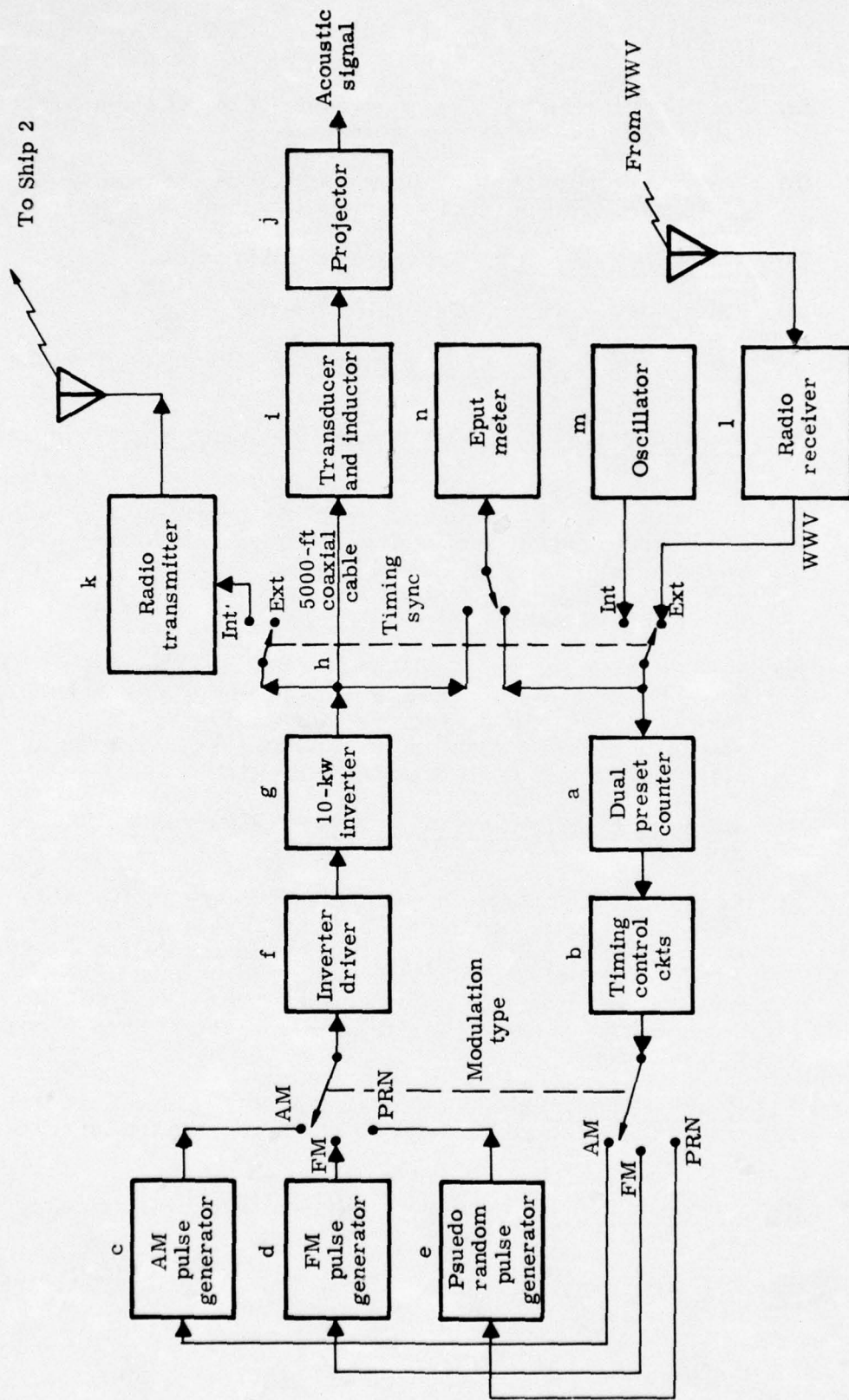

Fig. 2. Ship 1 Equipment, Block Diagram

CONFIDENTIAL

- (a) Dual preset counter. Standard item; generates synchronous pulse width and pulse repetition rate.
- (b) Timing control circuits. Starts and stops the various pulse generators from manual and preset counter signals.
- (c) AM pulse generator. Generates the AM pulse.
- (d) FM pulse generator. Generates the FM pulse.
- (e) Pseudorandom noise pulse generator. Generates the pseudo-random pulse.
- (f) Inverter driver. Makes the pulse generator signal compatible with the inverter.
- (g) 10-kw inverter. Supplies 10 kw to the projector and cable. It embodies small size, high efficiency, wide frequency range and load immunity. It was developed as part of the Martin ASW component development program and was supplied for use in this contract.
- (h) Projector cable. Originally to be GFE, but was not available because of its continued requirement on the Martin NUOS Taut Wire Array program. Because of this, 12,000 ft of double-armored coaxial cable (Martin property, used in Martin-NRL propagation tests) was utilized.
- (i) Matching transformer and inductor. Matches the projector to the low impedance coaxial cable.
- (j) Projector. Originally it was planned to use an available MBP-2 projector for the tests, but a scheduling conflict existed with the Taut Wire Array program. To alleviate this, a GFE model MBP-2 projector (built by Martin for NRL) was borrowed from NRL for this program. The unit had been slightly damaged by NRL and was repaired by Martin prior to use.
- (k) Radio transmitter and antenna. Supplied by ship's subcontractor; used to send a replica of the transmitted acoustic signals to Ship 2.
- (l) WWV receiver and antenna. External synchronized time reference.
- (m) OSC. Standard item furnished by Martin Laboratory Stockroom; used as an internal time reference.

CONFIDENTIAL  
ER 12316

- (n) EPUT meter. Standard item furnished by Martin Laboratory Stockroom; used to accurately check system frequencies.

Other items which were required on Ship 1 but are not shown in the diagram are listed below:

- (a) Bathythermographs. GFE.
- (b) B-T winch. Supplied by ship's subcontractor.
- (c) Radar. Supplied by ship's subcontractor.
- (d) Fathometer. Supplied by ship's subcontractor.
- (e) Decca navigation. GFE (permanent Decca was not available in time and Decca Hifix was extended to allow utilization on this program).
- (f) Ship-to-ship and ship-to-shore radio. Supplied by ship's contractor.
- (g) Projector winch. Furnished by ship's subcontractor.
- (h) Acoustic pressure levelmeter. Available at Martin; used to measure transmitted source level.

## 2. Ship 2 Equipment

The block diagram for Ship 2 equipment is shown in Fig. 3. The function and source of each item are discussed below:

- (a) Hydrophone. Available at Martin from another program.
- (b) Preamplifier. Same design as FAB but modified to include a calibration resistor.
- (c) 1500-ft, 4-conductor cable. Purchased item.
- (d) Amplifier. Boosts the acoustic signal to a reasonable level.
- (e) Amplifier-speaker. Standard purchased item; used to allow aural monitoring.
- (f) Radio receiver and antenna. Standard item furnished by ship's subcontractor; used to obtain timing reference signal from either WWV or Ship 1.
- (g) Oscillator. Standard item furnished by Martin Laboratory Stockroom; used to calibrate hydrophone preamplifier.

CONFIDENTIAL

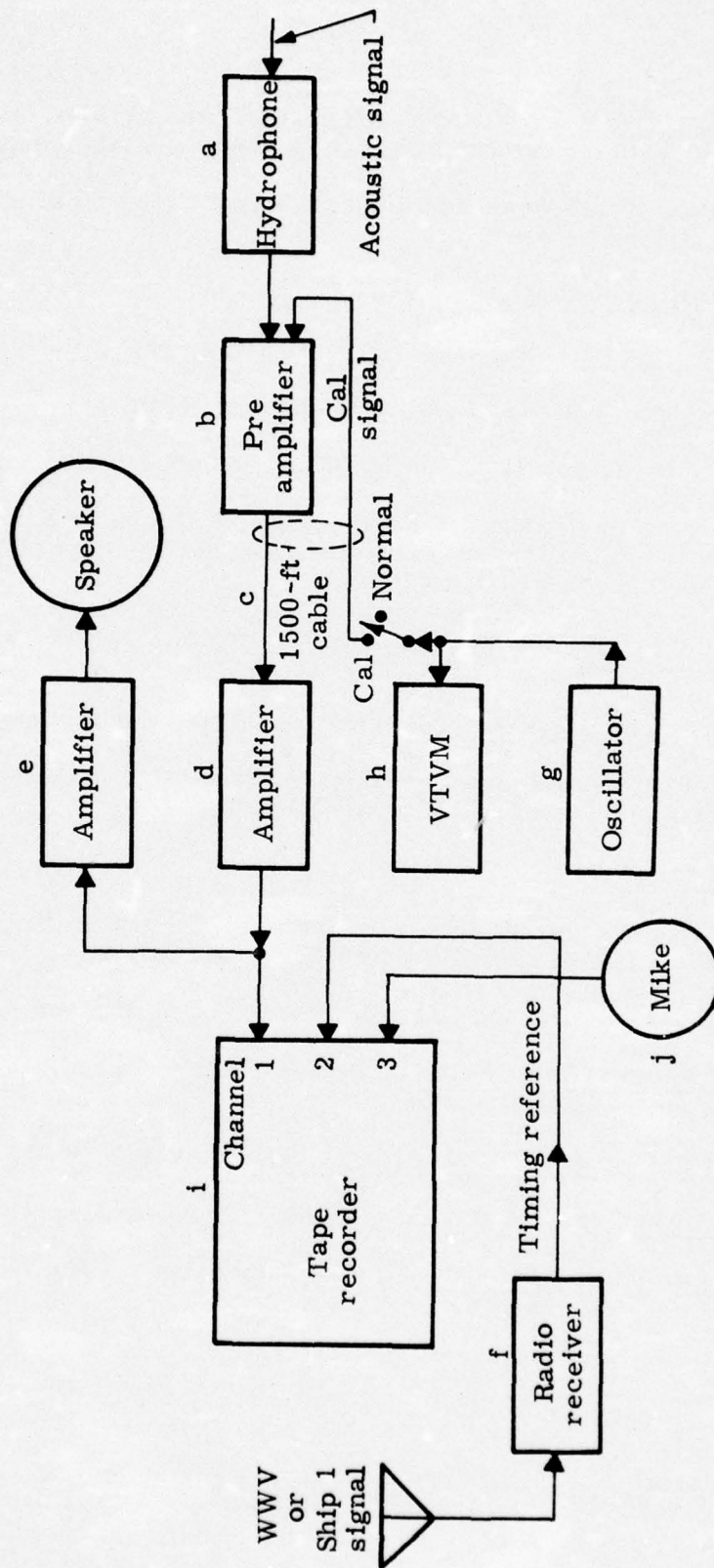

Fig. 3. Ship 2 Equipment, Block Diagram

- (h) VTVM. Standard item furnished by Martin Laboratory Stockroom; used to measure calibration voltage.
- (i) Tape recorder. Standard item furnished by Martin Laboratory Stockroom; used to record the radio and acoustic data.
- (j) Microphone. Standard item furnished by Martin Laboratory Stockroom.

Other items required on Ship 2 but not shown in Fig. 3 are as follows:

- (1) Bathythermograph. Standard GFE item.
- (2) B-T winch. Standard item furnished by ship's subcontractor.
- (3) Radar. Standard item furnished by ship's subcontractor.
- (4) Fathometer. Standard item furnished by ship's subcontractor.
- (5) Decca navigation. GFE (permanent Decca system was not available in time and Decca Hifix was extended to allow utilization on this program).
- (6) Hydrophone winch. Furnished by ship's contractor.

Ship subcontractor items referred to above are items that are subcontractor-owned shipboard equipment.

The construction of the circuitry largely consisted of transistorized plug-in printed circuit cards. The same printed cards used on the Taut Wire Array program were used in most cases to minimize drawing and construction costs. The differences between the two designs are reconciled by using different components and mounting them in different locations.

## B. SHIP'S SERVICES

A specification for the ship services required was sent to Geraldines Ltd, Byrd Undersea Technology Corporation, Marine Acoustical Services, U.S. Underseas Cable Corporation, Cleveland Pneumatic Industries, Inc., and R. W. Stusch and Company. A copy of this specification is included as Appendix A.

On the basis of the replies, the choice of ship's services was initially narrowed down to Geraldines Ltd and Byrd Undersea Technology Corporation. The first subcontractor was the most attractive price-wise, very cooperative, and had ships which were small (97 and 63 ft) but

CONFIDENTIAL

adequate. The second subcontractor was second low bidder, also very cooperative, but had much larger ships (130 and 100 ft) which were very stable and could operate easily in Sea State 3. The second subcontractor, located in Miami, had a steaming time to Nassau of only one day; while the first, located in Annapolis, required six days to Nassau. The advantage of the larger ships was that the percent utilization would be considerably higher as far as weather and sea state were concerned and, therefore, considering steaming time also, the total ship cost incurred using Byrd might be the same or less than Geraldines.

The decision was then made to use Byrd Undersea Technology Corporation's "Sea Search" for Ship 1 and Geraldines Ltd's "Earl of Desmond" for Ship 2 as the best combination from a cost and performance point of view. Shortly thereafter, the "Sea Search" was required to stand by for the Taut Wire Array program and could not be scheduled for use in this program. In addition, the change to the longer and larger projector cable put more stringent requirements on the winches and spools. The modifications required could not be accomplished in the short time available.

For the above reasons (and the fact that the cost per day was about the same), U.S. Underseas Cable Corporation's Cable Layer "Omega" was then selected for Ship 1. The cable machinery and equipment already in existence on this ship was more than adequate to handle the projector cable.

The Omega needed only a fathometer and a new UNQ-1. A fathometer was installed on the ship in early October in Norfolk, and since the projector cable was stored aboard the USS Hunting, which was also in Norfolk, a transfer of the cable was conveniently made there.

All ships under serious consideration were inspected by both Martin Engineering and Procurement personnel prior to the final choice.

The final ship's services contracts were submitted for the Contracting Officer's approval; on receipt of approval the Omega and the Earl of Desmond were put under contract.

### C. TEST PROGRAM

The data gathering portion of the experimental program was then completed using the equipment and ship's services discussed previously. The test procedure and the log of ship operation are discussed in this section.

#### 1. Test Procedure

The test procedure followed the original plan (Fig. 1) and is described in the following paragraphs.

CONFIDENTIAL  
ER 12316

Ship 1 (the Omega) transmitted acoustic signals at a depth of approximately 5000 ft of water and simultaneously transmitted a replica of this acoustic signal via an RF link.

Ship 2 (the Earl of Desmond) recorded on magnetic tape the acoustic signals received at depths from 100 to 1500 ft at 1-1/2-mi increments from the Omega. The RF replica was received and simultaneously recorded on another channel of the tape recorder in order to be able to determine acoustic signal travel times. Originally, Decca radio navigation was to be used for above water navigation to permit a comparison of these travel times with the range between the ships. The Decca navigation was not utilized, however, due to schedule conflicts and the untimely failure of the acoustic projector system.

FM pulse (swept pulse) signals were utilized most of the time in order to acquire AM and FM pulse performance data as well as bottom loss data as a function of frequency. At the end of every 1.5-mi increment, pseudorandom noise (PRN) pulses were transmitted to compare the performance of this type of modulation with AM and FM pulses.

The transmitting ship was supposed to take five positions (corresponding to initial beacon locations) and the receiver ship was to make one run from shore toward and beyond the transmitter ship, stopping every 1.5 mi to take recordings. Due to failure of the acoustic projector system matching transformer, only one-half of the Station 1 run was completed.

One additional test was originally planned to determine the travel time stability over a 24-hr period. This test was eliminated due to the problem of two ships staying on station within the 50-ft position accuracy required.

The test procedure and the ship locations for all the planned stations are described more fully in the operation plan which was included as Appendix A of Progress Report No. 3.

## 2. Log of Ship's Operation

The chronological events of the ship's operation are as follows:

- 15 Oct Loaded Ship 2 equipment on the Earl of Desmond at Annapolis, Maryland.
- 16 Oct Earl of Desmond departed Annapolis for Nassau, Bahamas. Loaded Ship 1 equipment on the Omega in Norfolk. Omega still undergoing Coast Guard inspection.

CONFIDENTIAL

- 17 Oct Omega loaded 12,000 ft of deep sea cable (for use with projector) from the USS Hunting in Norfolk. Omega Coast Guard inspection complete except for test of boiler safety valves.
- 18 Oct Omega departed Norfolk for Nassau.
- 19 Oct Ships en route.
- 20 Oct Ships en route.
- 21 Oct Ships en route.
- 22 Oct Earl of Desmond arrived at Nassau. Martin personnel arrived at Nassau.
- 23 Oct Ship 2 equipment set up and checked out on the Earl of Desmond.
- 24 Oct Omega arrived at Nassau.
- 25 Oct Ship 1 equipment set up and checked out on the Omega. Boiler safety valves being reworked. Hydrographic Office representative called and informed that the ships could not be in North Exuma Sound to use Decca Hifix before its scheduled removal on 26 Oct. Suggested immediate removal and transfer of Hifix to South Exuma Sound.
- 26 Oct Omega boiler safety valves installed but boiler failed pressure test due to defective hand hole cover.
- 27 Oct Ship ready at 12:00. Waiting for weather to improve.
- 28 Oct Departed Nassau for Exuma Sound. Weather still poor requiring long way to be taken around north side of Eleuthera.
- 29 Oct Extremely heavy seas on east side of Eleuthera. Turned around and returned to Nassau.
- 30 Oct Waiting for weather to clear.
- 31 Oct Waiting for weather to clear.
- 1 Nov Weather cleared. Departed Nassau for Exuma Sound via short way (south of New Providence). Omega at Position 1 (24° 43' 39" N latitude, 76° 36' 42" W longitude). Earl of Desmond on course 315° true from the Omega. Tests started.

CONFIDENTIAL  
ER 12316

2 Nov The following tests were then made.

<u>Run No.</u>	<u>Distance (naut mi)</u>	<u>Hydrophone Depth (ft)</u>	<u>Modulation</u>	<u>Remarks</u>
1 through 7	1.2	100	FM-2	No signal due to bad splice
	Splice repaired			Signal transmission resumed
8	Ship drifting	100	FM-2	Good signal to noise
9	Ship drifting	100	PRN	Good signal to noise
10	Ship drifting	100	FM-1	Good signal to noise
11	1.54	200	FM-1	Good signal to noise
12	2.4	200	FM-1	Good signal to noise
	No signal			Splice bad again
3 Nov				
	Repaired splice			Signal transmission resumed
13	1.7	400	FM-3	Good signal to noise
14	3.3	100	FM-3	Good signal to noise
15	4.9	100	FM-3	
16	4.9	100	FM-3	
17	4.9	100	FM-3	Added filter 700 to 1600 cps
18	Ship drifting	400	FM-3	

CONFIDENTIAL

<u>Run No.</u>	<u>Distance (naut mi)</u>	<u>Hydrophone Depth (ft)</u>	<u>Modulation</u>	<u>Remarks</u>
19	Ship drift- ing	800	FM-3	
20	Ship drift- ing	1500	FM-3	
21	5.27	1500	PRN	Fair signal to noise
22	6.5	100	FM-3	
23	Ship drift- ing	400	FM-3	
24	Ship drift- ing	800	FM-3	
25	Ship drift- ing	1500	FM-3	Good signal to noise
26	8.0	1500	PNG	
27	9.5	100	FM-3	
28	Ship drift- ing	400	FM-3	Poor signal to noise
29	Ship drift- ing	800	FM-3	Fair signal to noise
30	Ship drift- ing	1500	FM-3	Good signal to noise
31	12.5	1500	PRN	Good signal to noise
32	14.2	100	FM-3	Fair signal to noise
33	14.2	100	PRN	Fair signal to noise
	No signal			Matching trans- former shorted

CONFIDENTIAL  
ER 12316

- 4 Nov Earl of Desmond and Omega departed Exuma Sound for Nassau. No spare transformer available. Due to extended ship's service (about two weeks) required, overall good propagation received, repetitious nature of the remaining tests (except for being in different area) and unavailability of Decca Hifix after 10 Nov, it was decided that the operation should be terminated. Decca personnel in Georgetown, Great Exuma were informed by radio that the Hifix would not be utilized.
- 5 Nov Equipment dismantled and packed on Earl of Desmond and Omega. Martin personnel returned to Baltimore.
- 6 Nov Omega unloaded equipment onto Earl of Desmond and dock. Omega charter terminated.
- 7 Nov Loading of Earl of Desmond completed.
- 8 Nov Earl of Desmond departed Nassau for Annapolis, Maryland.
- 9 Nov  
through  
16 Nov Earl of Desmond en route.
- 17 Nov Earl of Desmond arrived at Annapolis.
- 17 Nov Earl of Desmond unloaded at Annapolis and charter terminated.

#### D. DATA REDUCTION

The data collected during the experimental program was analyzed in three different ways according to whether information on AM, pseudo-random or FM coded pulses was desired. In addition, all the data were analyzed to determine the propagation characteristics. Each of these analysis methods is described in this section.

##### 1. AM Pulse Analysis

Actually no pure AM pulses were used in the experimental program. This was because the swept FM pulse resembled a series of short AM pulses at different frequencies and, therefore, could be treated as a composite of AM pulses. The analysis consisted of playing the FM signals through a set of 10 comb filters, demodulating each filter output received and then recording these outputs on 10 channels of a paper recorder as shown in Fig. 4. The radio reference pulse was recorded on another channel of the paper recorder and used as a timing reference. The paper recorder has sufficient speed such that the minimum travel time increment that can be read is 1 ms (5 ft).

CONFIDENTIAL

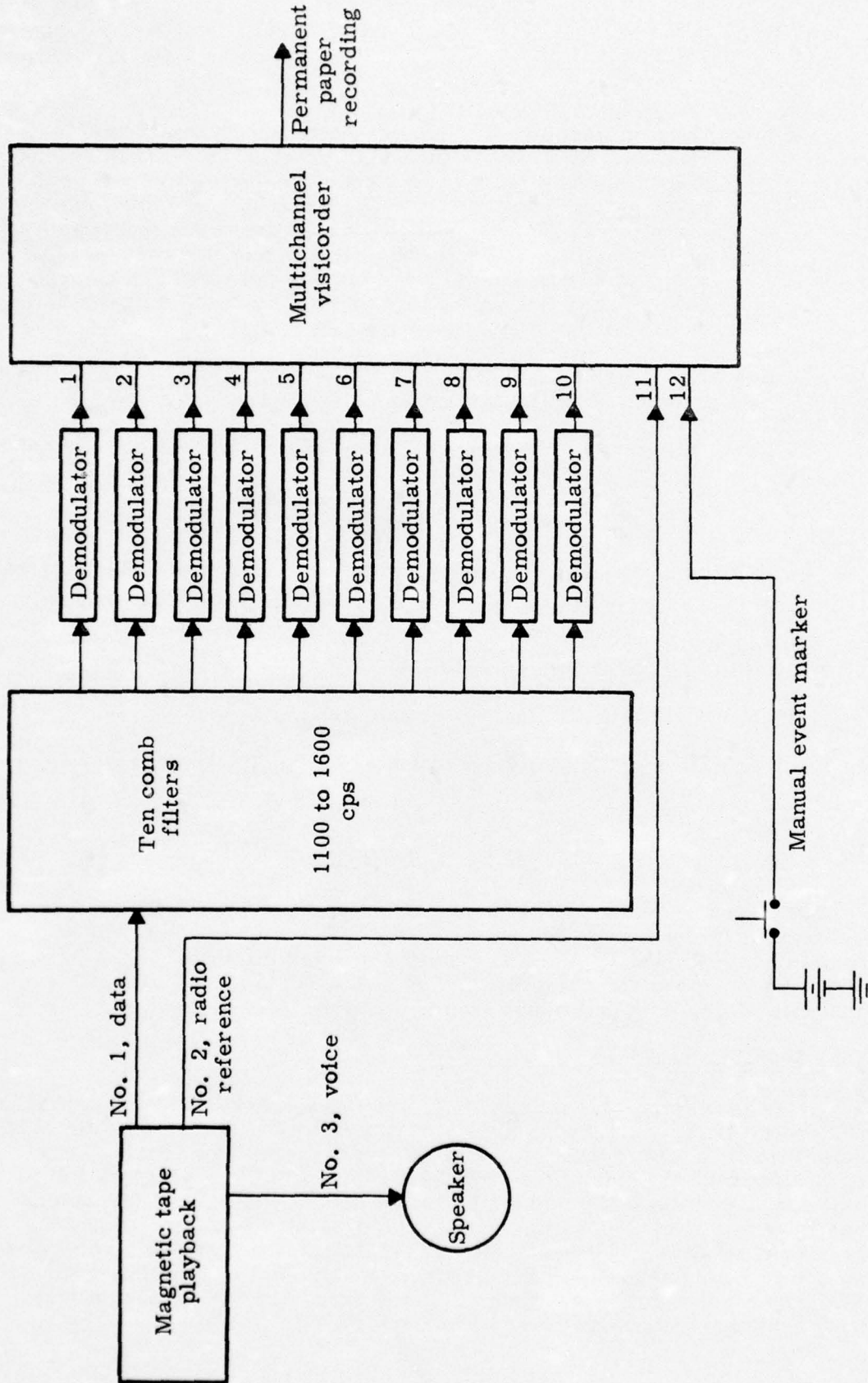

Fig. 4. AM Pulse Analysis Block Diagram

The 10 comb filters were each 50 cps wide and the FM pulse swept linearly from 1100 to 1600 cps in 300 ms. This meant that the output of each filter was the same as if a 30-ms pulse had been received in succession at each filter frequency. This can be seen in Fig. 5 where the radio pulse has been played through the analysis equipment, and the demodulated outputs of the 10 filters are shown. Each timing line corresponds to 100 ms and since the filter center frequencies are 50 cps apart, the separation of the maximum frequency of the first and last of the 10 filters is 450 cps. This means that at a sweep rate of 500 cps in 300 ms, the outputs of the filters from the top to the bottom should progress to the right of the page in 30-ms increments and the maximum output of the first and last filter should be separated by 270 ms. The lowest trace in Fig. 5 shows the input signal applied to the filter bank. The first 240 ms of the original signal covers the frequency range of 700 to 1100 cps and the signal shown has passed through a 1100-cps high pass filter to attenuate these lower frequencies.

Applying the recorded acoustic signals to the same setup gave the typical results shown in Fig. 6 for a range of 8.5 miles. The first pulse received came via the single-bounce path since there was no direct propagation path at this range. There was multipath interference due to the fact that a double-bounce signal (which was generated because the projector was 700 ft off the bottom) came in at about the same time. Almost complete phase cancellation occurred at some of the filter frequencies. This interfering signal would not be present with the projector at the bottom. Higher order multipath signals are also apparent after the main pulse.

AM timing accuracy was derived from this type of data by using higher oscillograph speeds and shorter integration time constants than those shown in Fig. 6, to obtain increased accuracy. One of the important items that was determined from this part of the analysis was that the pulse timing accuracy is not affected significantly (insofar as the intent of this study is concerned) by one or two bottom bounces. Analysis of signals received at 8.5 mi (undergoing one bounce) and 12.1 mi (undergoing two bounces) shows that the pulse timing accuracy and successive pulse-to-pulse travel time variations are on the order of  $\pm 3$  ms total or less for the combination of both effects. The stability of the timing was measured over four pulse periods (a total of 40 sec) and did not change measurably in that time. Actually, the  $\pm 3$  ms value is not really a measure of the maximum pulse timing accuracy and short term travel time stability, because this is the minimum time that can be measured with the signals that were sent and the analysis equipment being used.

The conclusions that can be drawn from the above analysis are that both short term (40 sec or less) travel time variations and degradation

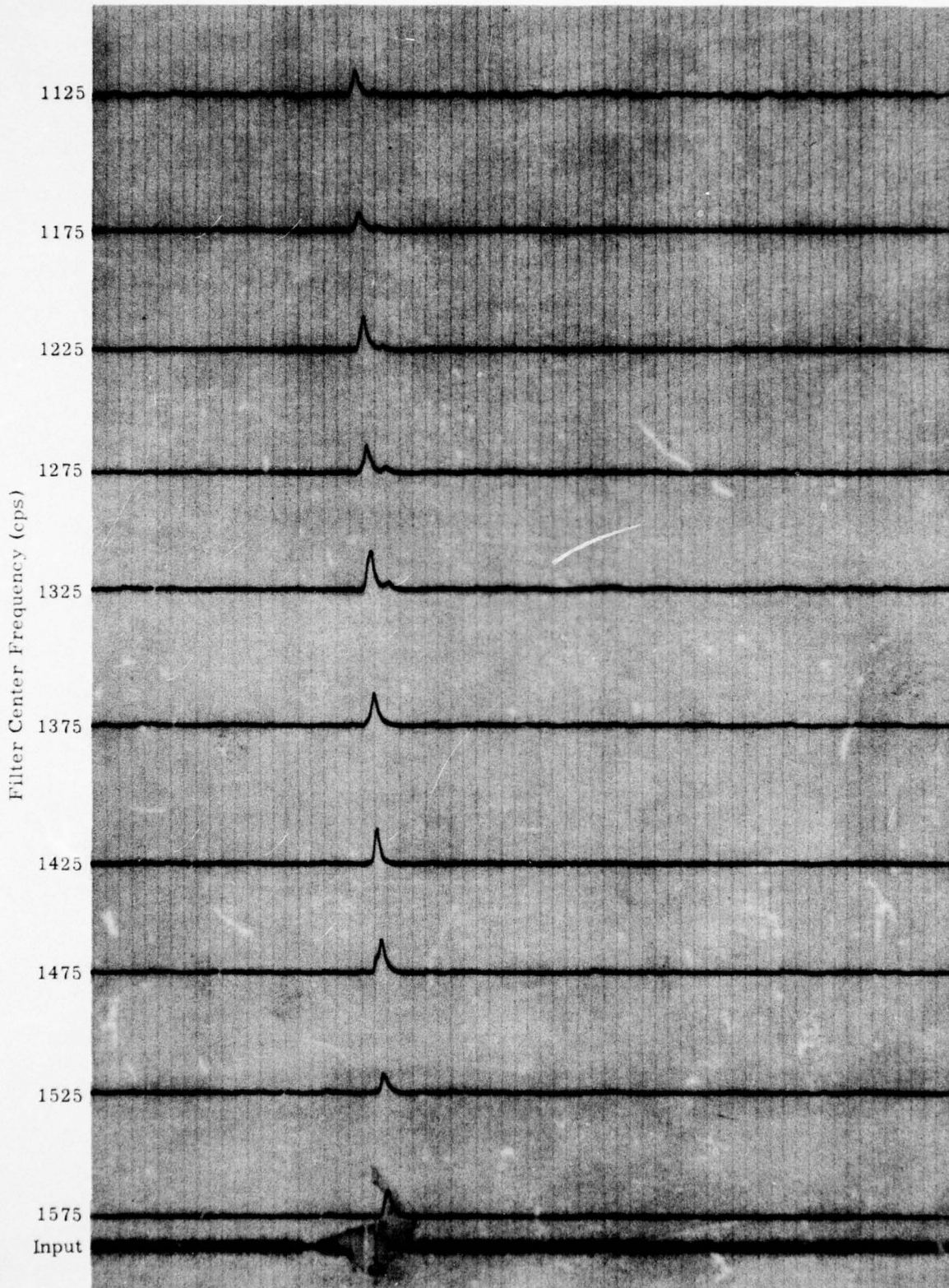

Fig. 5. FM-3 Radio Pulse--AM Analysis

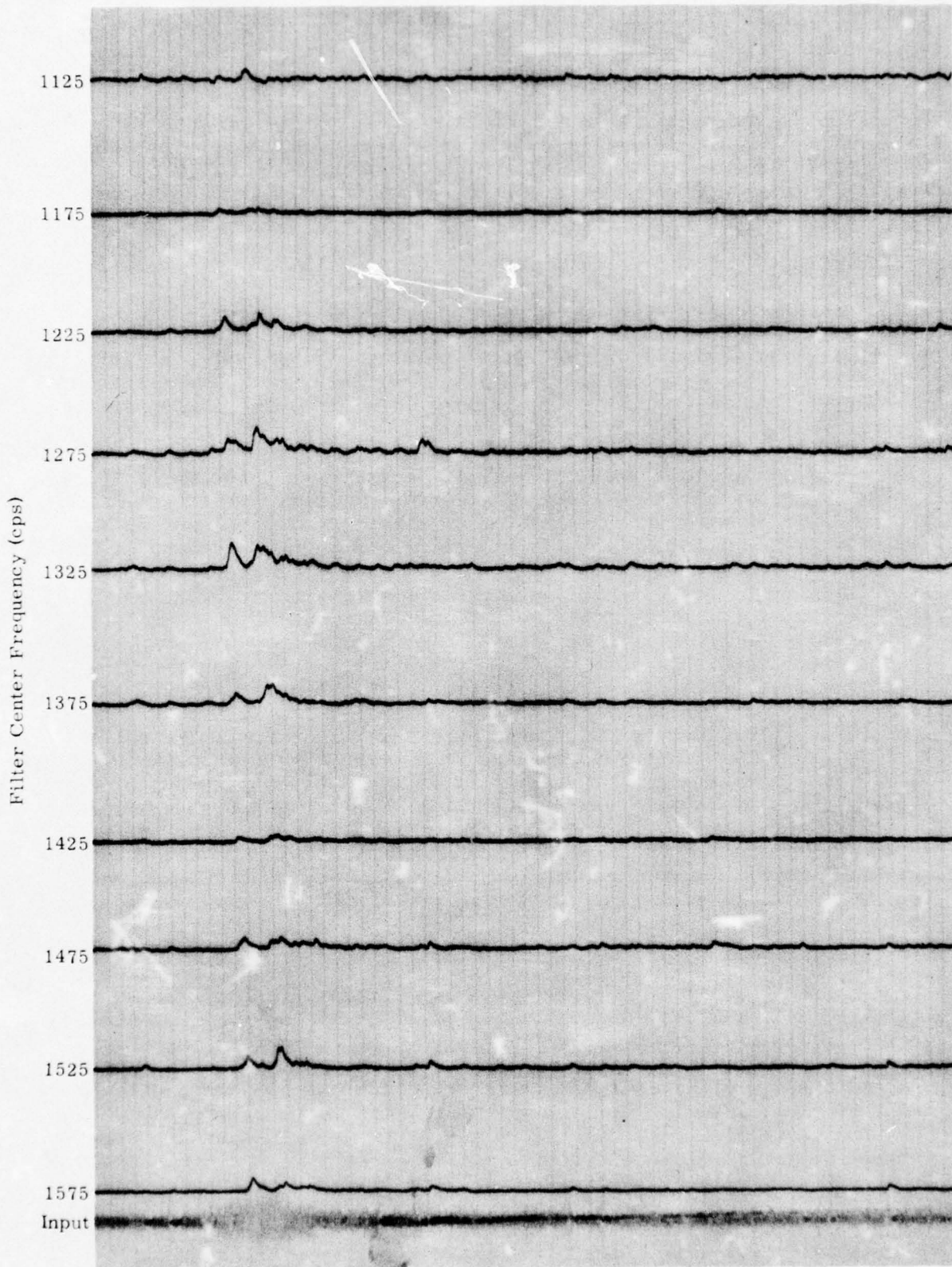

Fig. 6. 8.5-Mi,1500-Ft Acoustic Signal--AM Analysis

CONFIDENTIAL

of signals which have suffered a maximum of two bottom bounces are less than  $\pm 15$  ft. These two effects, therefore, contribute negligible error to the navigation system estimated accuracy of  $\pm 120$  ft. Of course, it is implied that sufficient signal-to-noise ratio (10 to 15 db) exists to permit measuring the pulse arrival time to the stated figure.

## 2. Pseudorandom Pulse Analysis

Pseudorandom pulses were transmitted at a depth of 1500 ft at horizontal ranges of 1.3, 5.4, 6.6, 8.5 and 12.1 mi. The pseudorandom coding was generated by shifting back and forth from a 1.1 to 1.6 kc carrier at a rate and period as determined by the pseudorandom sequence generator on the transmitting ship. The generated sequence was 31 bits long and lasted for 310 ms.

The received pulses were recorded and then played back and analyzed as shown in Fig. 7. The detector (or decision element) shown in Fig. 7 decides which of the two frequencies is stronger in successive bit periods and thus continuously creates a sequence as a function of time. The sequence is random when no signal is received and supposedly follows the original transmitted sequence when a signal is received. The sequence is then passed through a digital correlator which senses when the sequence is the same or at least almost the same as the original sequences. This output of the correlator and the radio reference signal were recorded on the same recorder used in the AM analysis.

The radio reference pulse was played through the analysis equipment to check the system operation under high signal-to-noise ratios and no multipath conditions. The resulting input to the correlator (the decision element output) is shown in Fig. 8. The input to the correlator is shown instead of the output because degradation effects are more easily understood when presented in this manner. The processed radio signal shown is a good replica of the transmitted signal (Fig. 9), and has a normalized correlation value of 1 (0 db) out of the correlator.

The recorded acoustic signals were also played through the analysis equipment with the results shown in Figs. 10 through 13 for ranges of 1.3, 5.4, 6.6 and 8.5 mi, respectively. The correlation values are 0, -5, -2 and -3 db for these ranges, respectively. The correlation for 12.1 mi is -5 db. In the runs shown, the signal-to-noise ratio after processing is sufficiently high so that only occasional noise bursts are let through and multipath interference is the main concern. As the range is increased, the interfering multipath signal comes closer in time to the direct signal (Fig. 11), and causes the decision element to be confused. As the range continues to increase, the multipath signal tends to merge with the direct signal, and the resulting signal is improved as shown in Fig. 12. With a further increase in range, the signal is degraded as a multipath signal of a higher order approaches the transmission time of the direct signal and the decision element is again

CONFIDENTIAL  
ER 12316

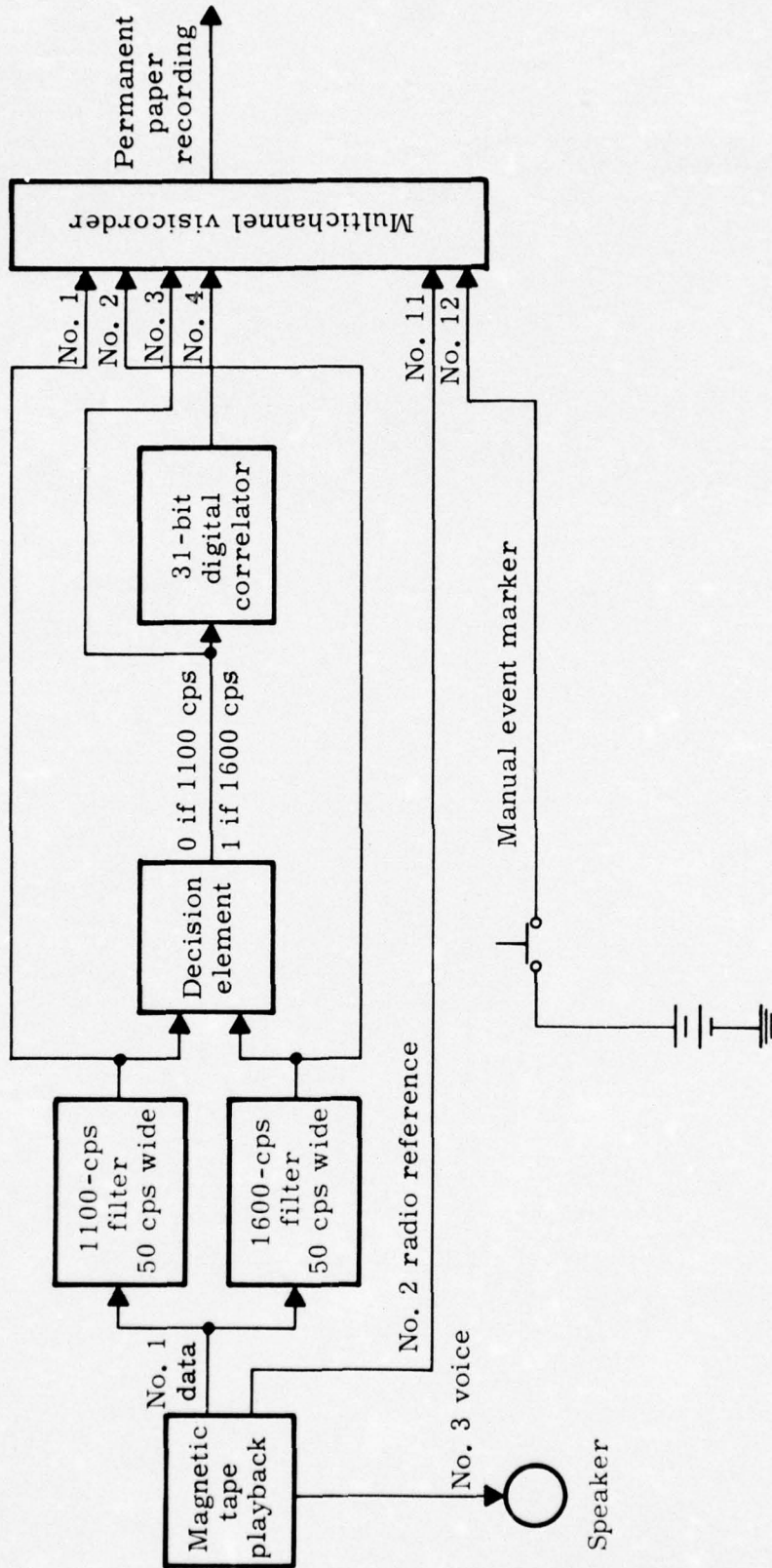

Fig. 7. Pseudorandom Pulse Analysis

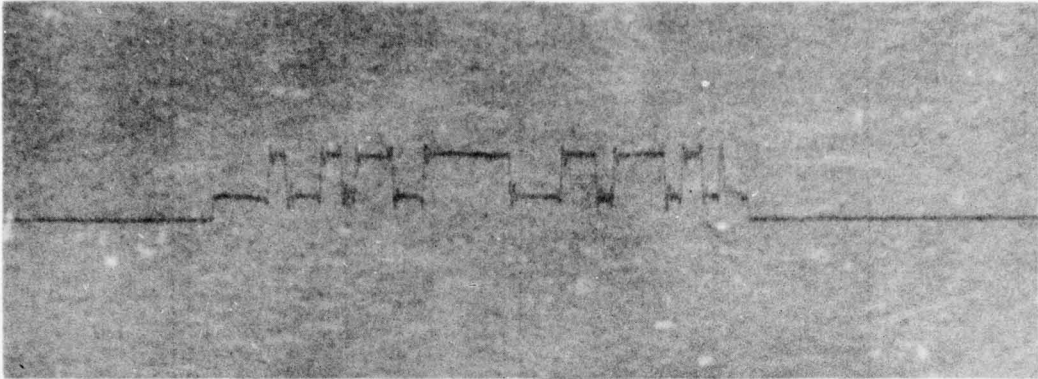

Fig. 8. PR Radio Pulse--PR Analysis

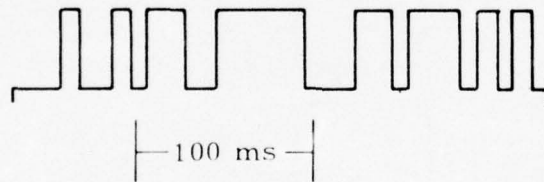

Fig. 9. Transmitted PR Pulse

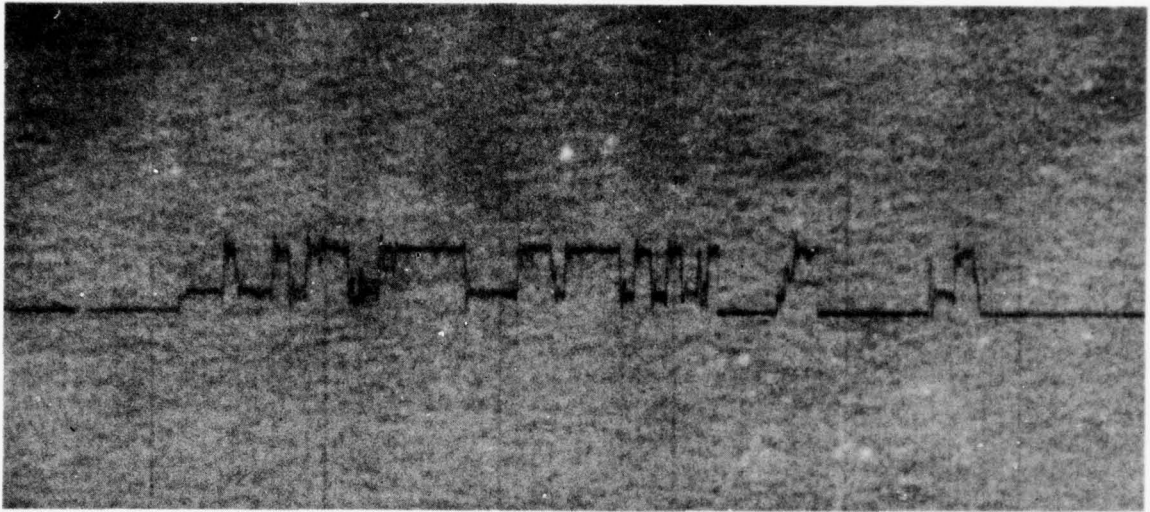

Fig. 10. 1.3-Mi, 100-Ft Acoustic Signal--PR Analysis

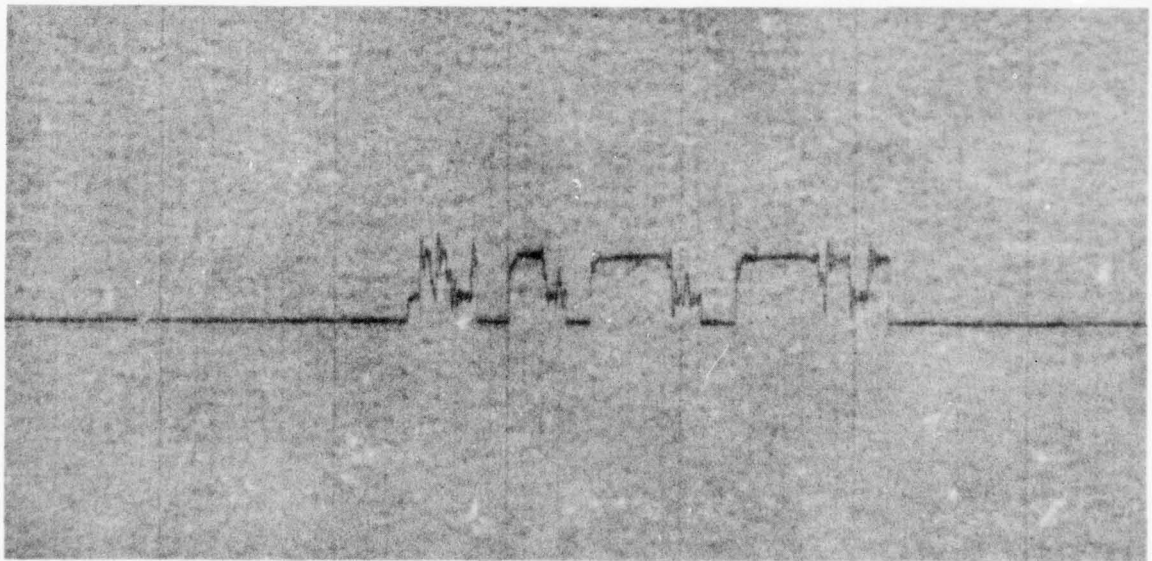

Fig. 11. 5.4-Mi, 1500-Ft Acoustic Signal--PR Analysis

CONFIDENTIAL

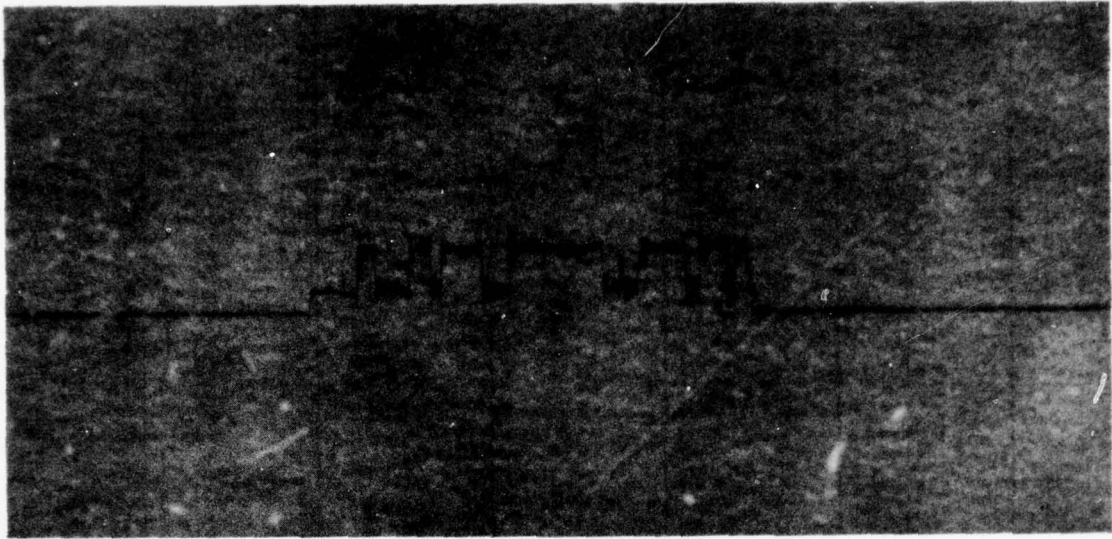

Fig. 12. 6.6-Mi, 1500-Ft Acoustic Signal--PR Analysis

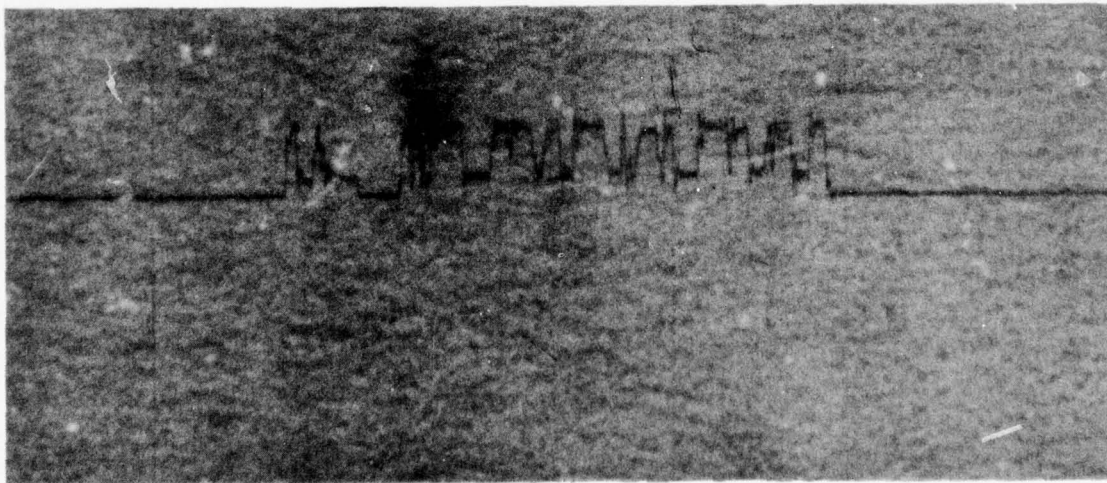

Fig. 13. 8.5 Mi, 1500-Ft Acoustic Signal--PR Analysis

CONFIDENTIAL  
ER 12316

confused (Fig. 13). The projector in the experimental program was 700 ft off the bottom, which gives rise to more multipath signals than would be encountered with the projector on the bottom. The results, however, show what can happen at positions where a multipath signal interferes with the direct signal, as happens frequently at longer ranges and shallower depths.

The correlation value for noise and differently coded sequences would be 12 db down from the correct signal value. Multipath signals can easily reduce this 12-db signal-to-noise improvement to 6 db, which is not considered significant. A further increase in bit length could improve the signal-to-noise ratio, but then the sequence would be adversely affected by doppler.

The purpose of using the pseudorandom pulse was twofold. First, it is a convenient method of station identification; second, extended pulse periods can be used while retaining high range resolution (allowing use of lower peak powers). In both cases, the pseudorandom coding loses its advantage and is unsatisfactory due to multipath effects. Pseudorandom correlators have been built that separate the different arrivals by true correlation (as opposed to postdetection integration as used here) but these require fairly complex equipment in the navigation receiver such as a Deltic correlator, and, therefore, will not be considered.

In conclusion, pseudorandom pulse coding in its conceived configuration is unsatisfactory for use in the Exuma Sound Submerged Navigation Aid.

### 3. FM Pulse Analysis

FM pulses were transmitted at all the depths and ranges involved in the experimental tests as discussed previously. The analysis of the received FM signals is accomplished as shown in Fig. 14. The recorded signal is played back and compared to an internal reference signal and the difference frequency between the two is generated. The frequency is then identified by the set of comb filters. The filter outputs are demodulated and displayed on the same multichannel paper recorder used in the AM and FM analysis. Again, the radio reference pulse is displayed on an adjacent channel and is used as a timing reference. The particular filter with the maximum output level identifies the fine range increment while the pulse arrival time gives coarse range. The FM processing thus utilizes the full pulse width to determine unambiguous fine range instead of relying only on the leading edge of the pulse as is done in the AM case.

The 10 FM filters used give a resolution of 150 ft (300-ms FM pulse divided by 10 filters = 30-ms resolution = 150-ft resolution). The FM

CONFIDENTIAL

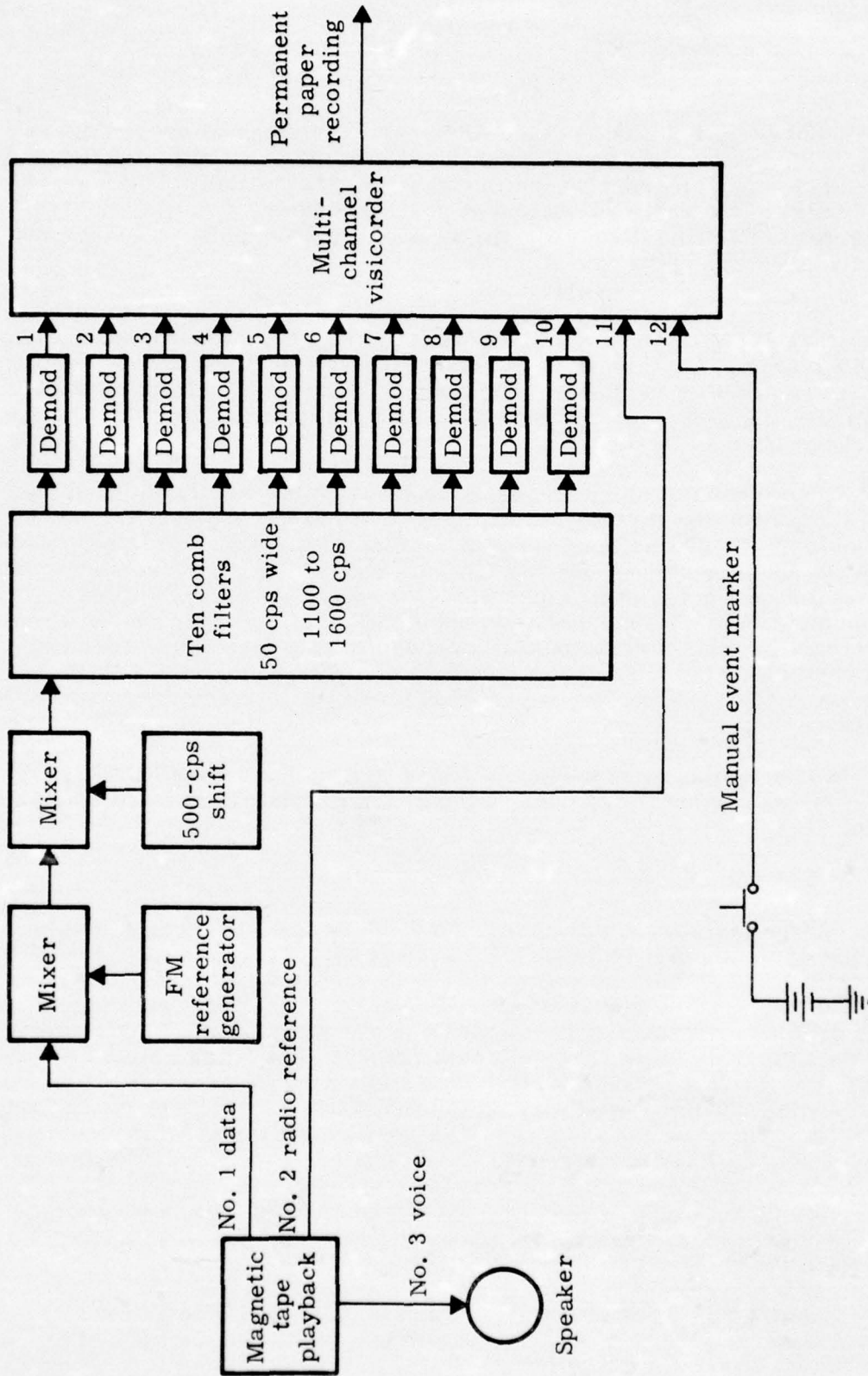

Fig. 14. FM Pulse Analysis Block Diagram

pulse length used was considerably longer than that originally contemplated for the navigation system (50 to 100 ms). This was done to allow the tape recorder level meters to respond to the pulses and thus prevent distorted data recording. The signal-to-noise ratio was sufficient (10 to 15 db) in most cases so the pulse arrival time could be determined to 3 ms by visual observation of the pulse amplitude as displayed on the paper recordings.

Initially, the full signal-to-noise improvement was not achieved due to two reasons. First, the FM reference oscillator suffered from frequency drifts and, therefore, the difference frequency did not lie within the correct filter for the full time period. Also, the filter skirts (-12 db per octave) were not sharp enough to reject adjacent frequencies and spurious frequencies which are generated during the FM processing (and which lie outside the frequency band of interest). These two items were corrected by addition of an Automatic Frequency Control circuit to the FM reference generator and the inclusion of new filters with rejection bands of -40 db which resulted in considerable improvement.

The result of playing the radio pulse through the FM analysis circuits is shown in Fig. 15, where each filter output corresponds to a 150-ft range increment. The timing lines are 100 ms apart and the input signal to the filter bank is illustrated by the last trace shown in the figure. There is some initial feedthrough of the 700- to 1100-cps portion of the pulse as can be seen, due to the fact that the high pass filter cutoff is not extremely sharp. This effect is not present with the acoustic data signals because the projector response is poor in this frequency band and the signals were received with reasonable energy only in the 1100- to 1600-cps band. The resolution capability of the processing is clearly shown and it is obvious that the 300-ft filter has the highest output. By observation of the relative filter outputs, it is also obvious that the signal was received almost equally well on the 150-ft filter. From this it can be interpolated that the signal fine range increment was about 235 ft.

The typical output for an acoustic signal is shown in Fig. 16 for a range of 2.0 mi and a depth of 400 ft. As can be seen, the direct pulse is received at a fine range increment of 150 ft and the first multipath signal is received at a range increment of 600 ft. This gives a range difference of 450 ft for the two signals which checks with the time delay between the two signals which is approximately 100 ms. This illustrates how the use of this type of processing allows the correct range increment to be determined even if time is not precisely known to better than a 1500-ft increment. Many other multipath signals are also obvious from Fig. 16. Data for other ranges are shown in Figs. 17, 18 and 19 for ranges of 6.6, 8.5 and 12.1 mi, respectively.

These figures graphically show the suitability of the FM pulse (and subsequent processing) for timing purposes.

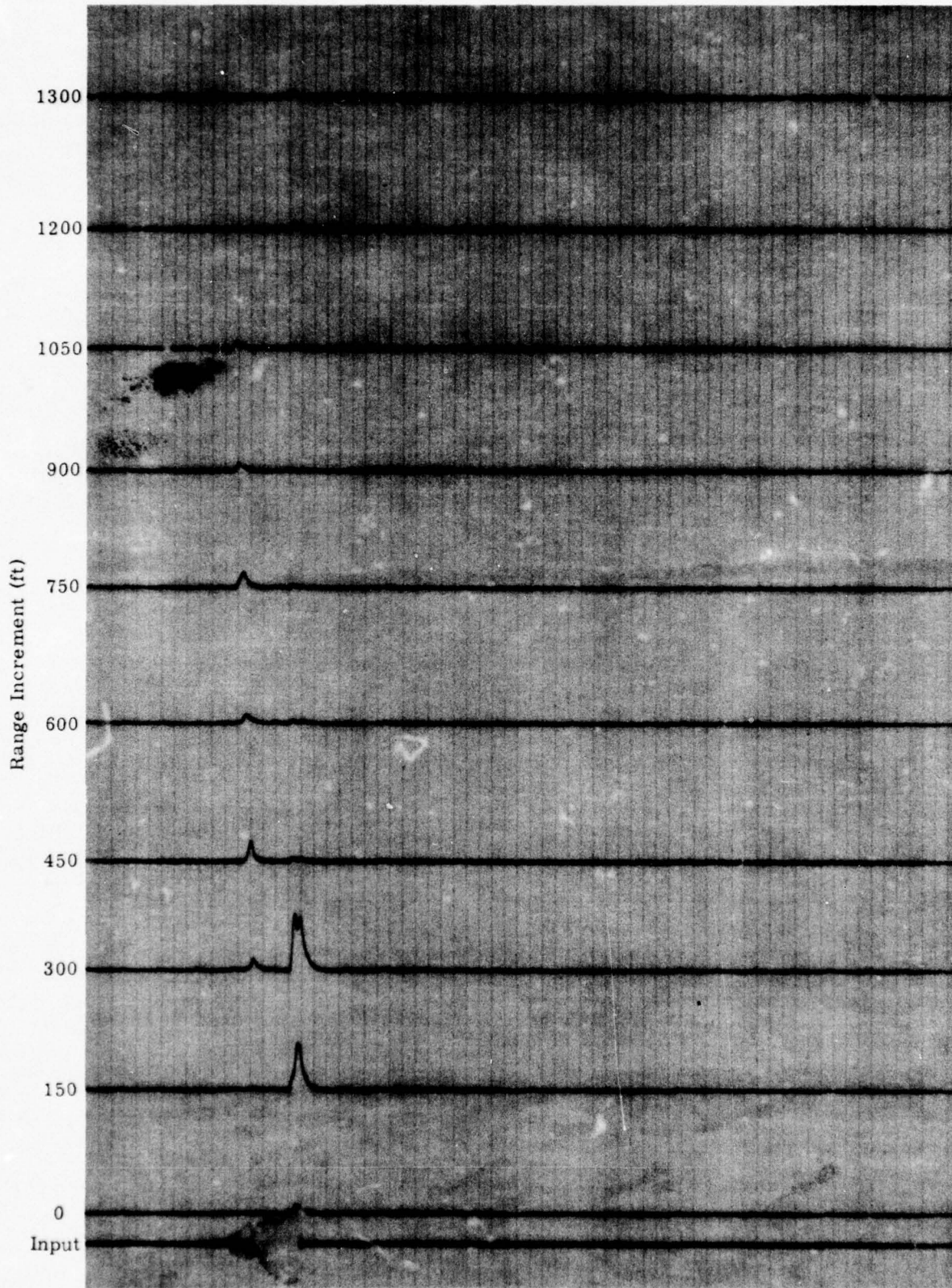

Fig. 15. FM-3 Radio Pulse--FM Analysis

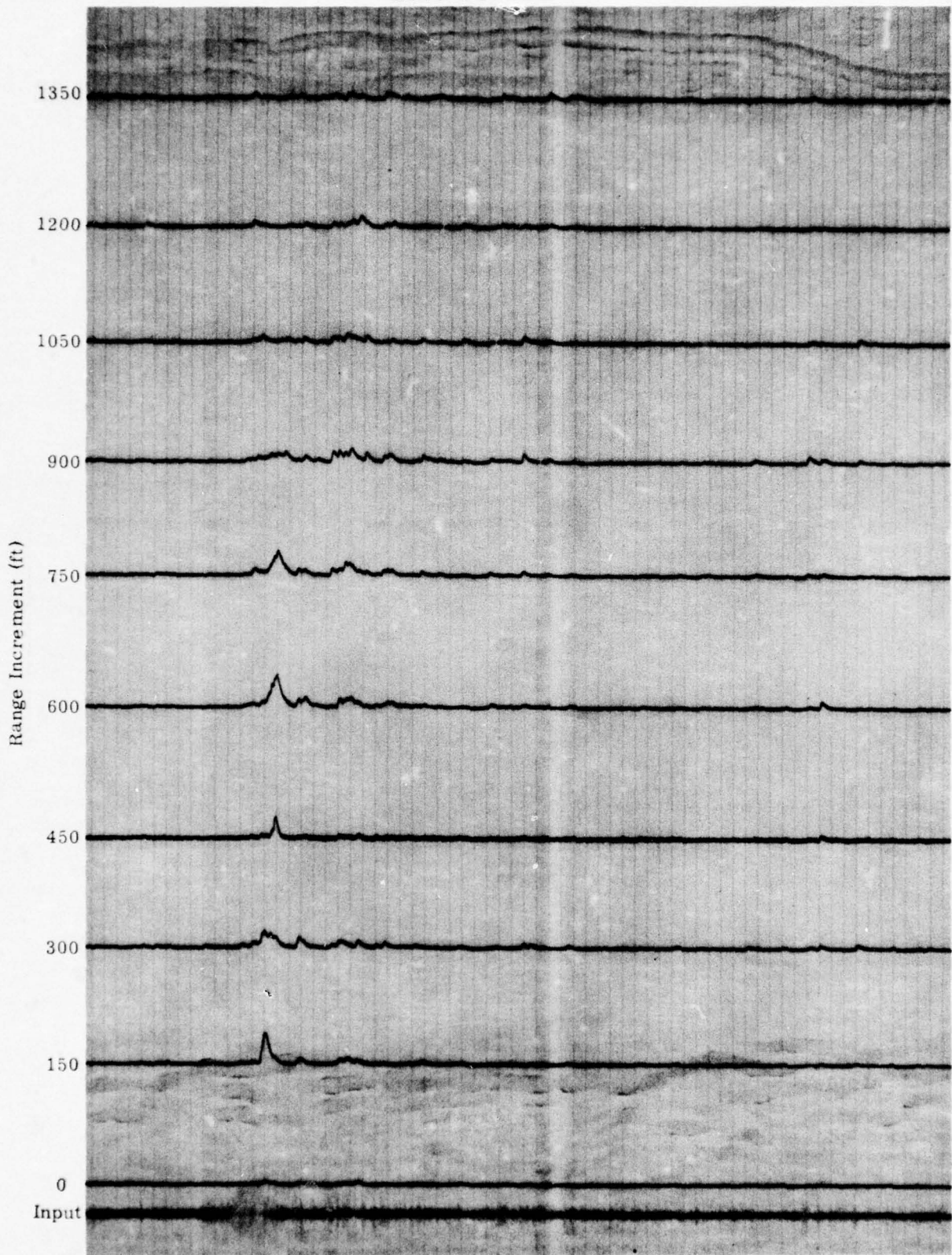

Fig. 16. 2-Mi,400-Ft Acoustic Signal--FM Analysis

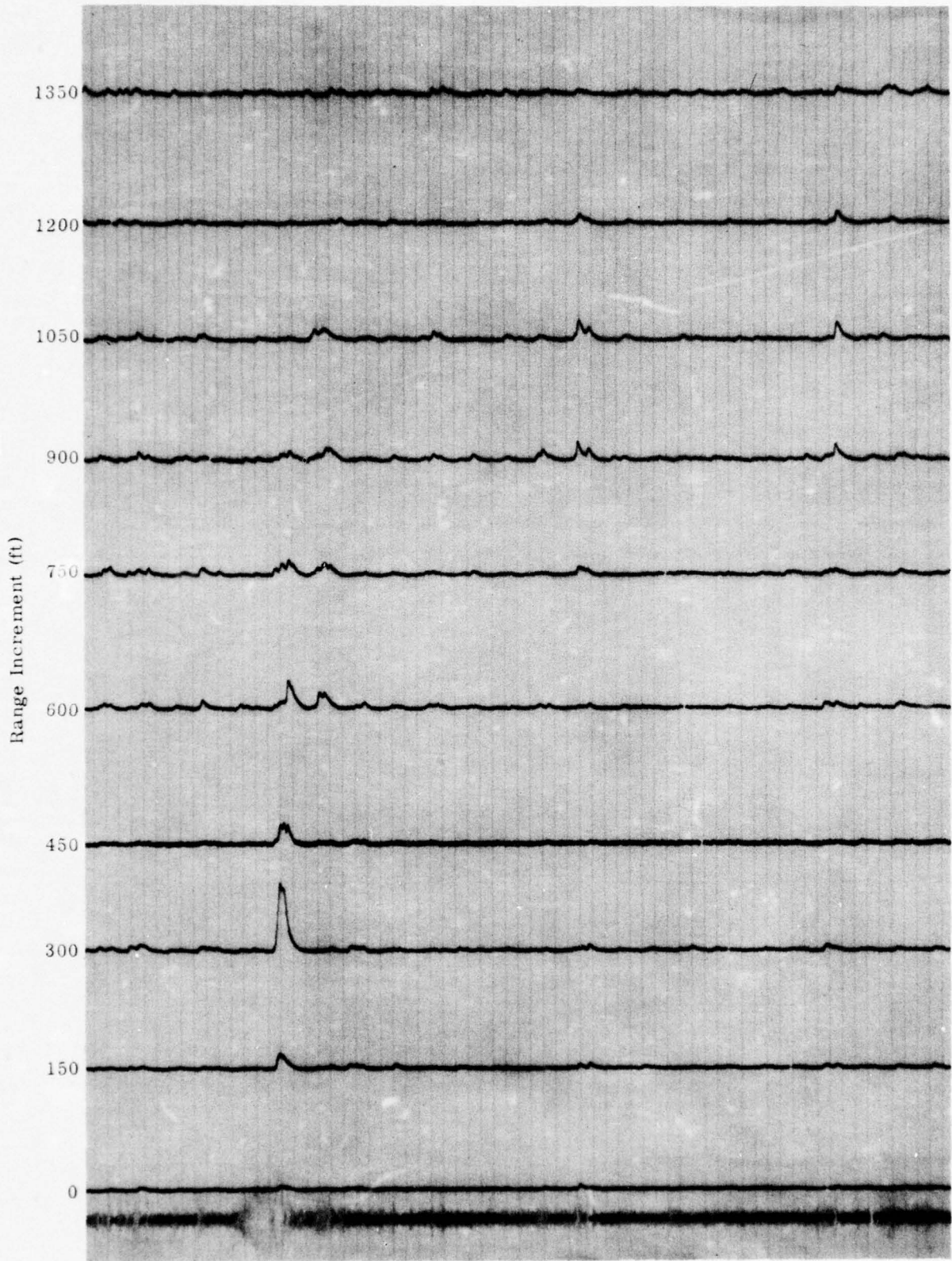

Fig. 17. 6.6-Mi, 1500-Ft Acoustic Signal--FM Analysis

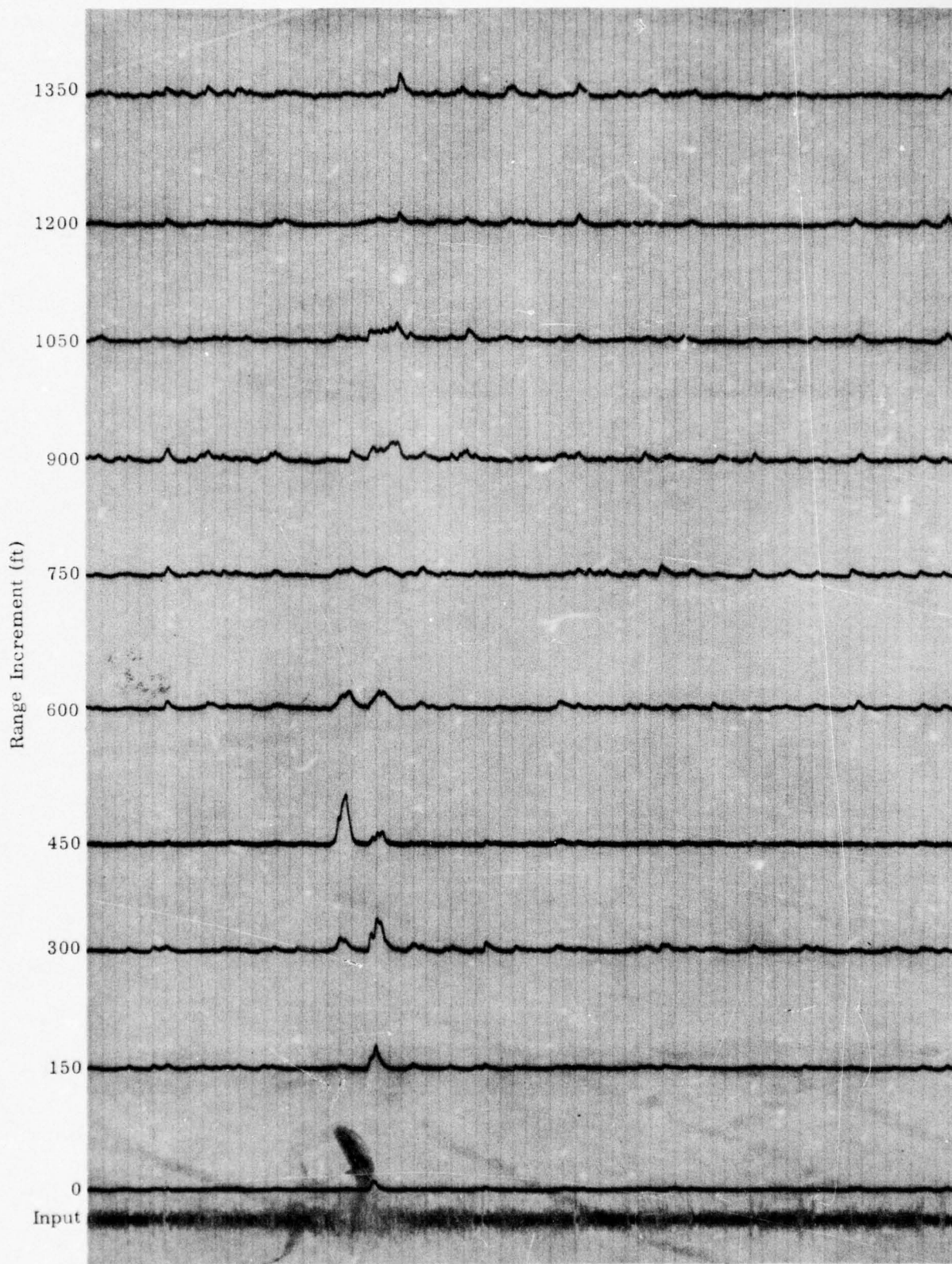

Fig. 18. 8.5-Mi,1500-Ft Acoustic Data--FM Analysis

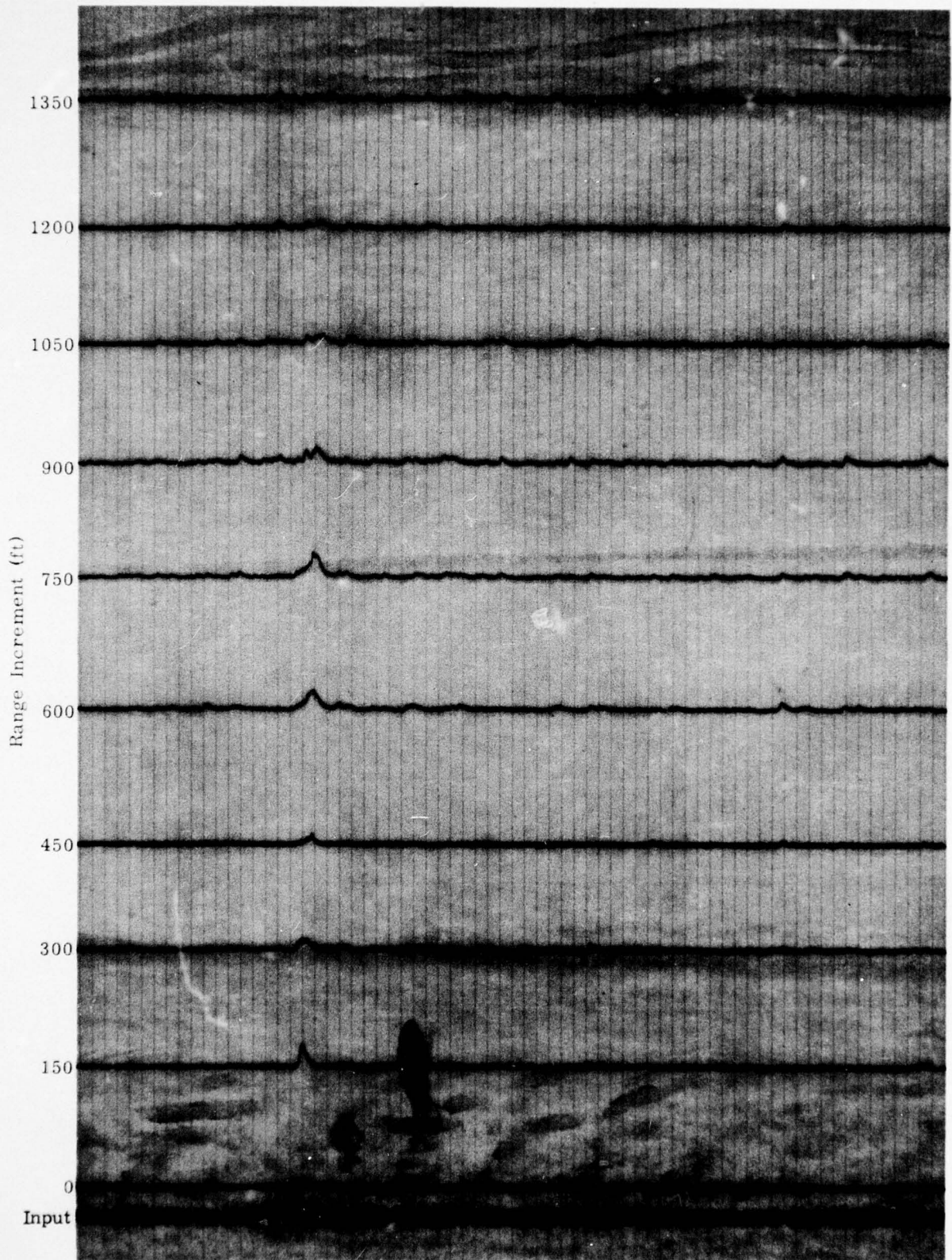

Fig. 19. 12.1-Mi,100-Ft Acoustic Data--FM Analysis

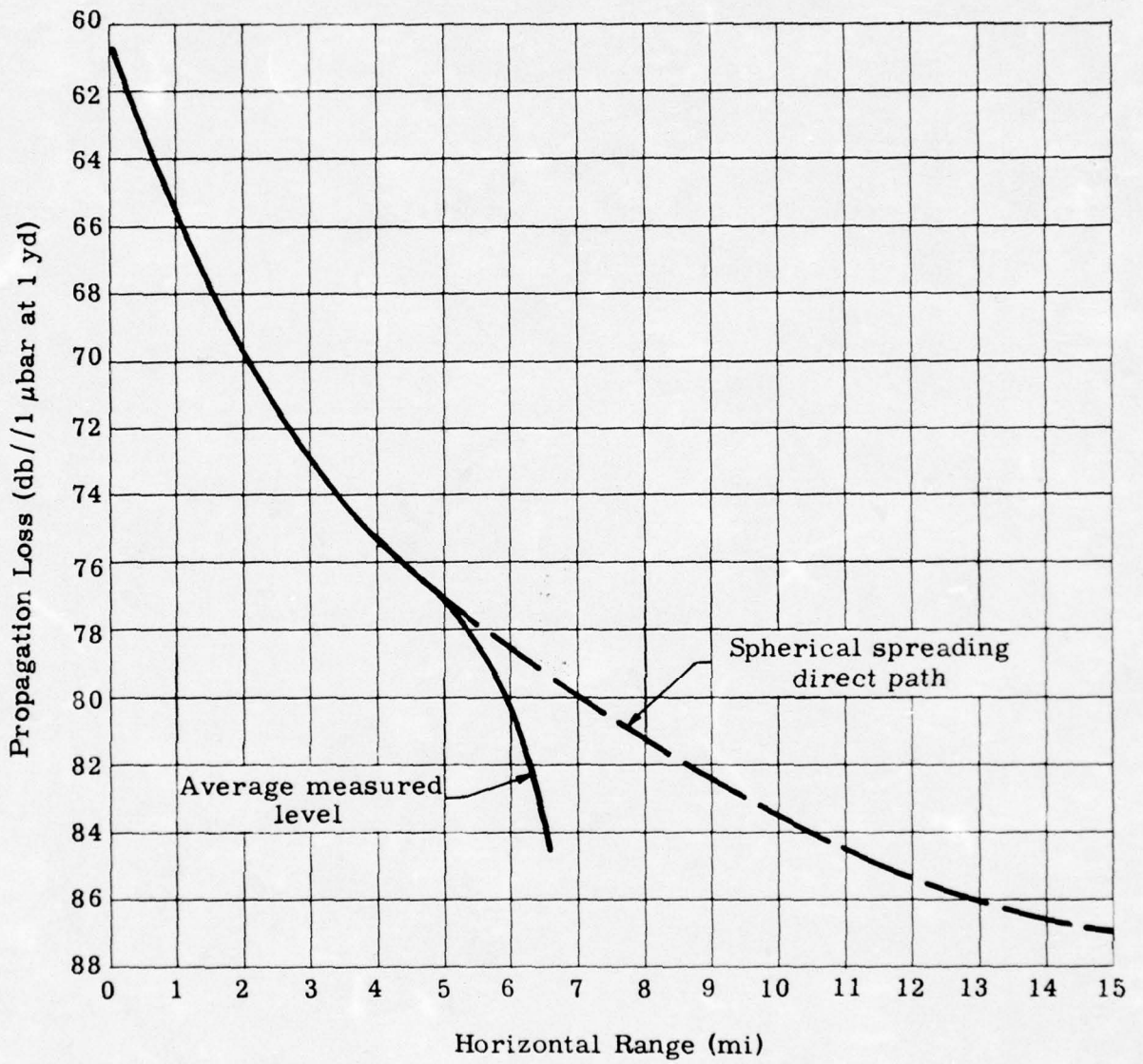

Fig. 20. Direct Propagation Loss

CONFIDENTIAL

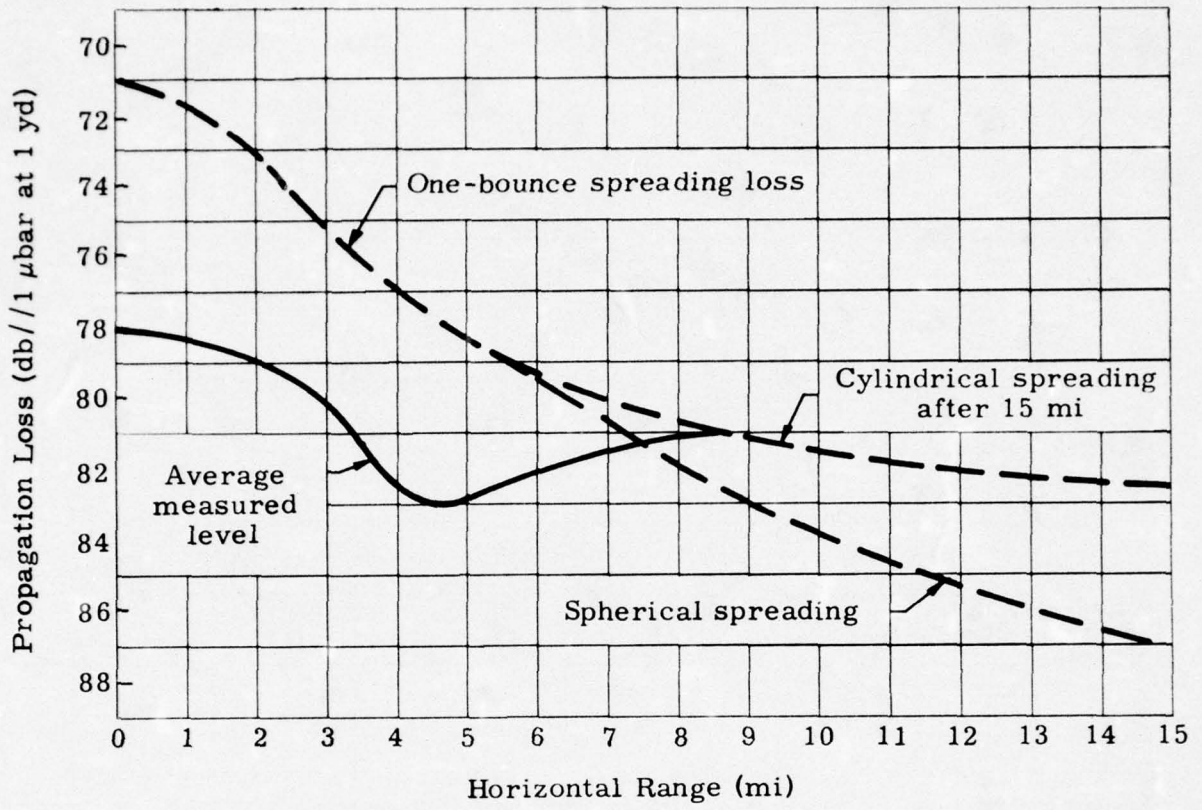

Fig. 21. Single-Bounce Propagation Loss

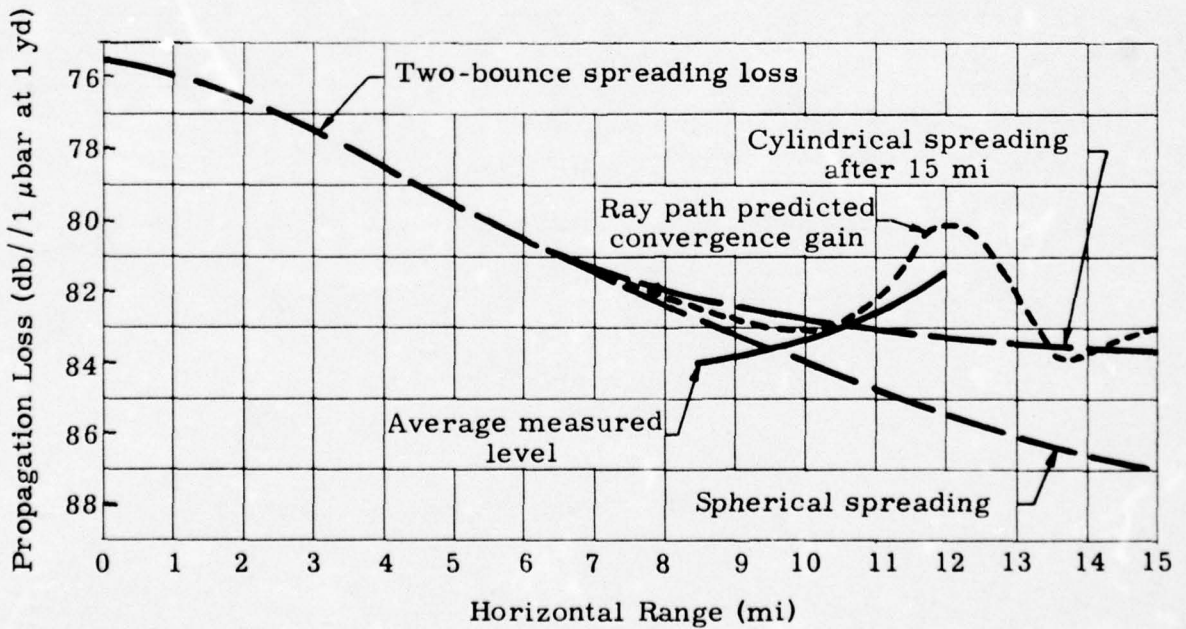

Fig. 22. Double-Bounce Propagation Loss

CONFIDENTIAL

ER 12316

#### 4. Propagation Losses

The results of the propagation losses in the direct path are shown in Fig. 20. Theoretical losses assuming spherical spreading and an attenuation of  $0.01F^2$  (kc) db/kiloyard are shown along with the measured level. The ray paths predict spherical spreading to 5 mi and then a sharp increase in loss. As can be seen, the agreement is good.

Figure 21 shows the single-bounce propagation loss data. Here, the theoretical losses start as spherical but the ray paths show that the losses become cylindrical at the 15-mi point. The predicted losses are higher than the direct case at the shorter ranges because the bounce signal has to travel to the surface, to the bottom and back to the receiver instead of directly to the receiver. Attenuation is included as before. The data points and average level are also shown.

Figure 22 shows propagation loss for the double-bounce data. Again the path length is longer due to two excursions between the surface and bottom. In this case, however, the receiving ship was proceeding toward shallow water and the ray paths predict a convergence gain over and above the cylindrical spreading.

Taking the differences between the ray path predicted losses and the measured losses as a function of range and angle gives the curve of Fig. 23. Figure 23 also has two curves of bottom bounce loss at 1.5 and 1.0 kc taken from "The Summary of Underwater Acoustic Data (SUAD)," Part VII, March 1956, by R. Urich and A. Pryce. As shown, the agreement between the Exuma Sound and SUAD data is very good.

The FM pulse was swept from 700 cps to 1.6 kc with the intent of getting bottom bounce loss as a function of frequency as well as angle. However, the source level of the projector used in the tests drops off rapidly below 1100 cps and the noise received at the hydrophone increases rapidly below 1100 cps. The combination of these two effects limits the usable signal frequency range to the band from 1100 to 1600 cps. Since this band is only one-half octave wide, the variation in bottom bounce signals as a function of frequency is somewhat lost in the normal pulse amplitude variations. The data, concerning bottom loss with frequency, shows that the losses at 1100 cps tend to be a few db lower than at 1600 cps. For future study, the previously referenced SUAD report will be utilized to obtain bottom losses as a function of frequency and angle since there is good agreement between it and the Exuma Sound data. The SUAD data and measured data agreed well within experimental accuracy. Plotting the propagation losses as a function of range and using either direct or single-bounce losses, depending on which is less, gives the curve shown in Fig. 24. As can be seen, the direct signal is usable to 6.5 mi even though it is rapidly departing from spherical spreading.

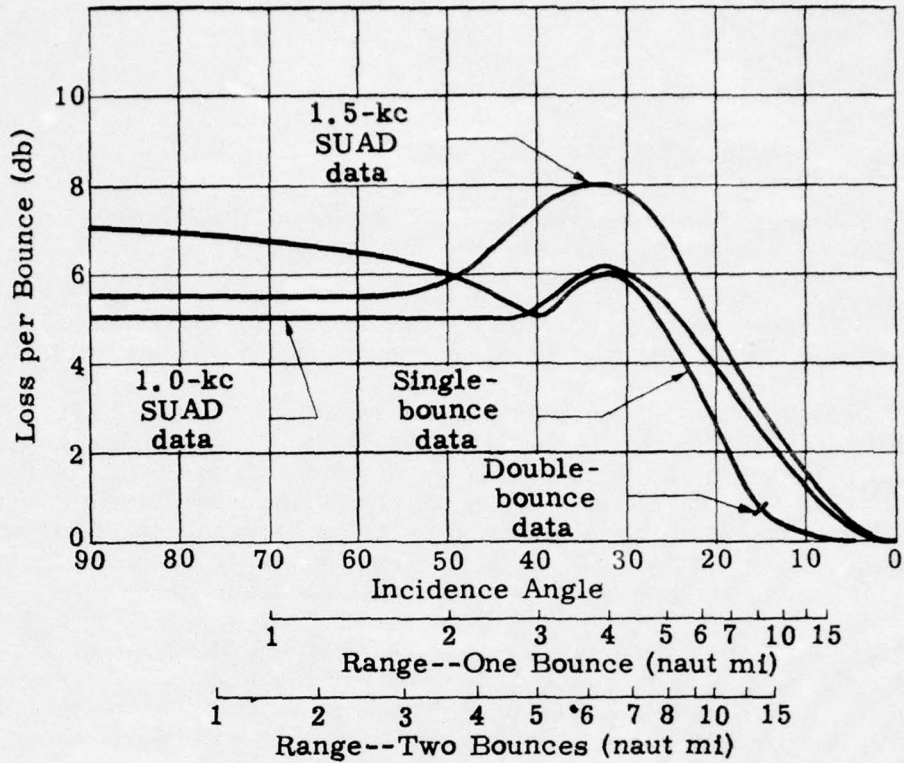

Fig. 23. Exuma Sound Bottom Loss Data (average of 1.1 to 1.6 kc, November 1961, North Exuma Sound)

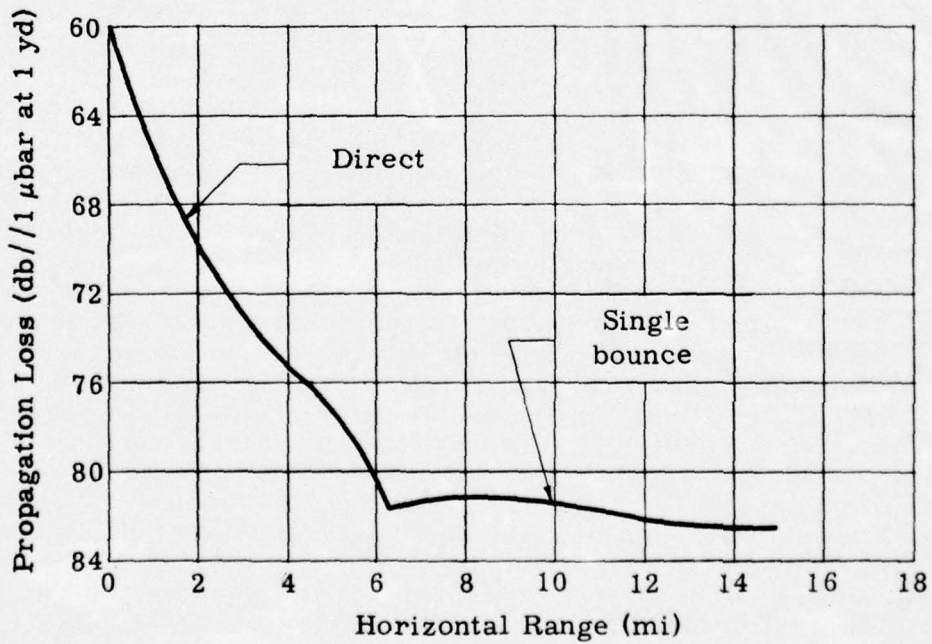

Fig. 24. Composite Propagation Loss

The conclusions drawn from the bottom bounce data are that bottom bounce propagation is good in Exuma Sound and the bottom bounce losses at the required ranges (5 to 15 mi) are not significant, since the bottom bounce propagation loss is approaching 0 db at the maximum range of 15 mi.

#### IV. CONFIGURATION STUDY

The configuration of the system can now be completely determined with the additional data inputs of the experimental program. The configuration includes many factors: basic computer geometry, propagation mode, optimum frequency, bandwidth, pulse coding, repetition rate, rate, station placement, station identification, transmitter characteristics, synchronization and navigation computer configuration. Some of these items can be determined independently while others are mutually dependent to a high degree. Each of these factors is discussed in detail in this chapter. Section A describes the system requirements and Section B discusses the block diagrams of the various system components. The system requirements are covered in detail in the system specification, included as Appendix C.

##### A. SYSTEM REQUIREMENTS

###### 1. Basic Computer Geometry

Several types of navigation geometry are possible, depending on two basic factors; first, whether the submarine transmits actively or listens only, and second, whether range differences between three beacons, ranges to two beacons, or range and bearing to a single beacon are utilized in the position computation. In any case, a dead reckoning computer would be used to continuously compute submarine position and the sonar navigation aid would only be required to periodically correct the dead reckoning computer.

A navigation system requiring an active system can be ruled out immediately on two counts. First, active signals give away the submarine position too readily and can be used to the submarine's disadvantage during an operational exercise. Secondly, the submarine and beacon equipment involved are more complex, since each has to transmit and receive instead of the beacon only transmitting and the submarine only receiving as in the passive case. Therefore, the passive system is best from operational, economical and reliability points of view, and is the general type of system to use for the Navigation Aid.

The choice between the specific geometry involved is easily made for the following reasons. First, any system involving a bearing to a station can be ruled out because the bearing accuracy required (about  $0.05^\circ$  at 5 mi and about  $0.02^\circ$  at 15 mi) is too high for any existing system and the existing submarine passive systems could not afford to be tied up in the navigation problem continuously. Of course, a separate passive system (probably using the same hydrophones) could be installed on each submarine. However, the system would not be accurate enough

CONFIDENTIAL

and the installation would be time consuming and costly. The range differences solution is attractive at first glance because it doesn't require a digital clock for synchronization between the beacon and the submarine, but it requires three beacons to be in range as opposed to two for the ranges only case. However, many digital clocks can be purchased for the cost of a 50% increase in the number of stations. Also, corrections for ray path errors are much more difficult in a range differences case since the distance the sound energy has traveled and the propagation mode are not immediately apparent when the range to each station is not implicitly known. The only acceptable system left is the ranges only type. Time synchronization between transmitter and receiver is required, but this can be easily realized by using digital clocks to control transmission and to determine travel time.

The ranges only computer geometry is shown in Fig. 25. The computer position can be solved by either analog or digital means, as indicated. A beacon range of 15 mi would require an overall accuracy of  $\pm 0.1\%$ , which can be achieved by analog means. However, it would require a lot of trimming, adjusting and calibration. It would, therefore, seem reasonable to use analog methods if short range beacons are used (5- to 7-mi range) and digital methods if long range beacons are used (7- to 15-mi range).

The passive, ranges only, type of underwater navigation system with digital clock synchronization is then the system that should be used in the Exuma Sound Operational Range.

## 2. Propagation Mode

The next item to be considered is the propagation mode to be used. This, of course, depends on acoustic conditions in the area. Ray path diagrams are shown in Figs. 26, 27 and 28 for the average, maximum and minimum depth velocity profiles in the Exuma Sound area. Only the rays emanating between  $\pm 10^\circ$  and  $+30^\circ$  to the horizontal are shown for clarity. As can be seen, direct coverage (without bottom bounce) extends to only about 5 mi in the 150- to 1500-ft depth region of interest. On the other hand, a single bottom bounce extends the range to approximately 15 mi. Thus, the choice of propagation mode is between a 5-mi range direct system or a 15-mi range bottom bounce system. Factors such as cost, variation with velocity depth profile, separation of arrivals, propagation loss, and pulse degradation with bottom bounce must be considered in this choice.

To cover the approximately 40- x 100-mi area of Exuma Sound would require about 140 of the 5-mi systems and about 20 of the 15-mi systems. It is obvious that the cost of installation, location, and maintenance of the short range systems would be extremely high as compared to the long range systems (see Chapter V). On the other hand, it is equally

CONFIDENTIAL  
ER 12316

Digital Solution

$$(x - x_1)^2 + (y - y_1)^2 = r_1^2$$

$$(x - x_2)^2 + (y - y_2)^2 = r_2^2$$

Analog Solution

$$x = x_1 + r_2 \sin(\alpha + \gamma)$$

$$y = y_1 + r_2 \cos(\alpha + \gamma)$$

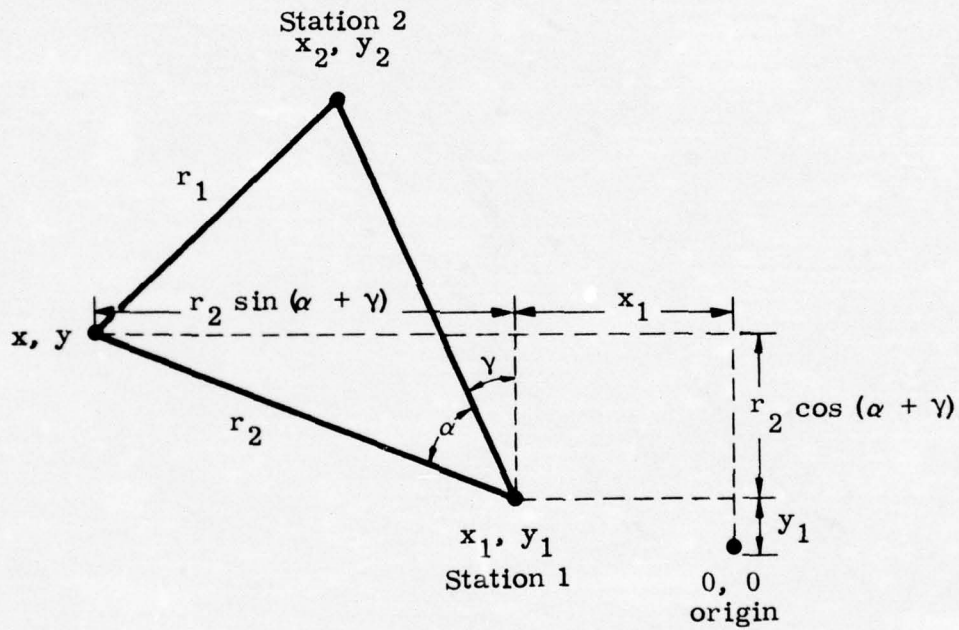

Fig. 25. Ranges Only Computer Geometry

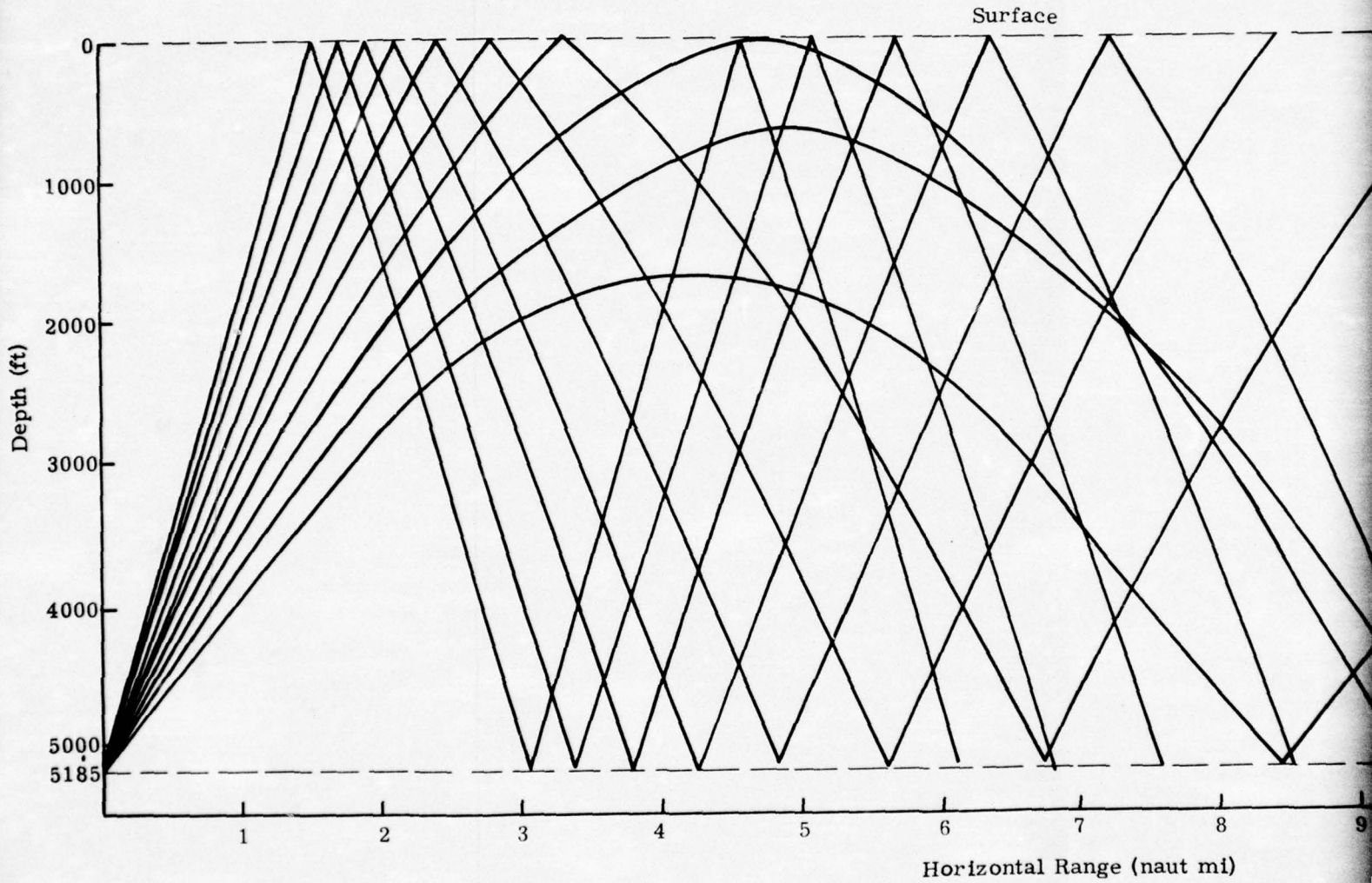

Fig. 26. Ray Path for

CONFIDENTIAL

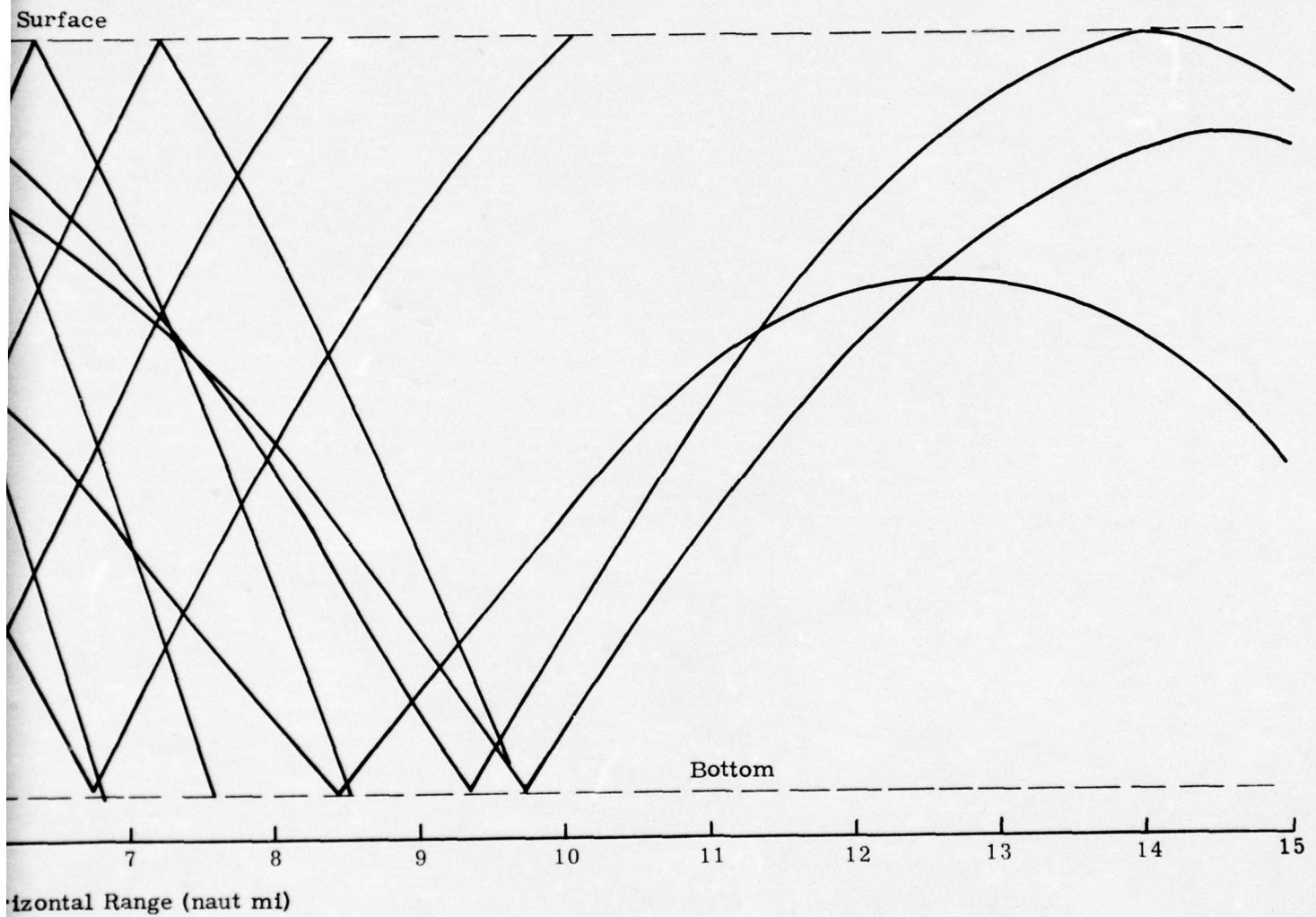

Fig. 26. Ray Path for Average Depth-Velocity Profile, Exuma Sound (source on bottom)

CONFIDENTIAL  
ER 12316

2

CONFIDENTIAL

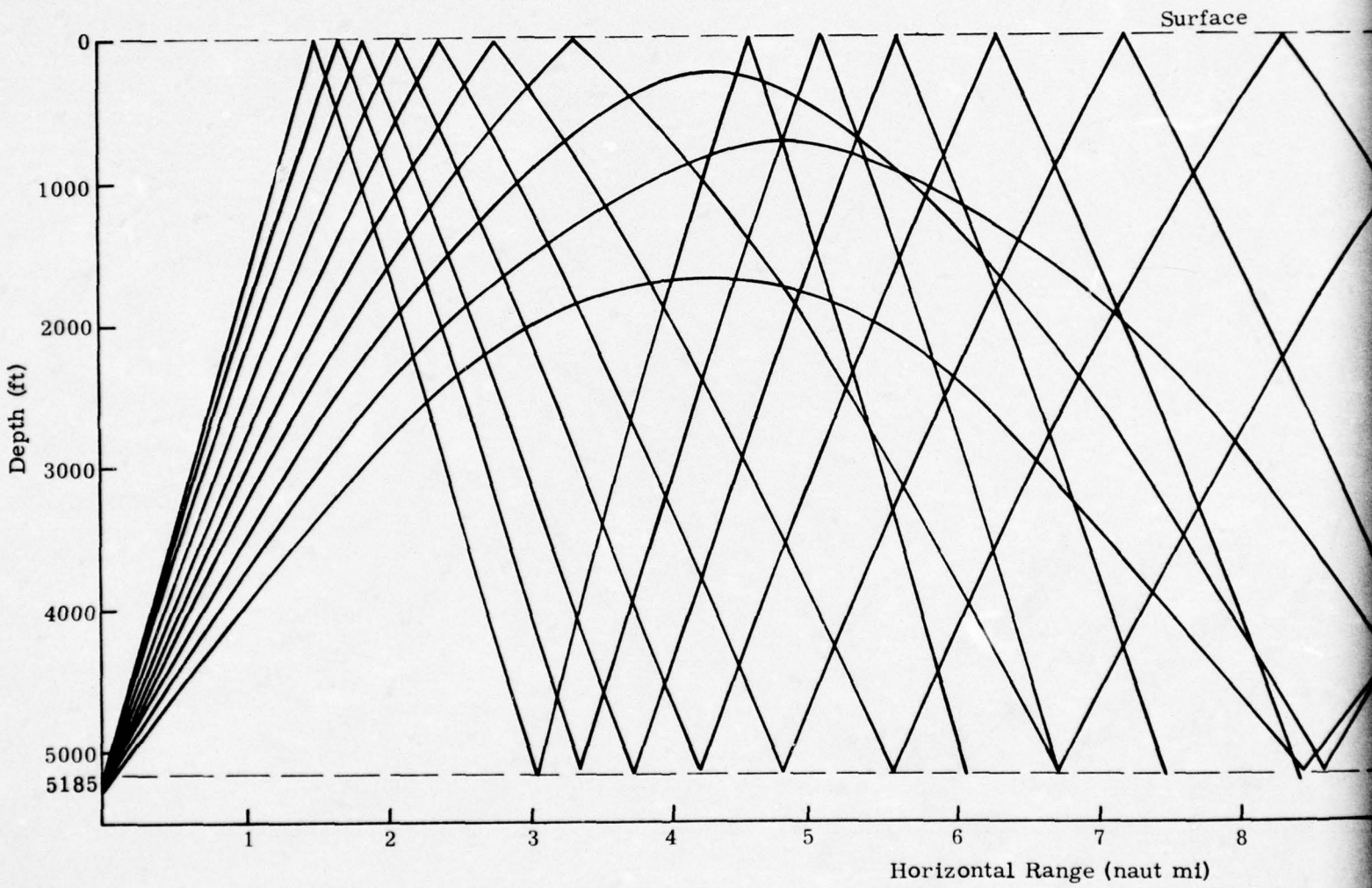

Fig. 27. Ray Path fo

CONFIDENTIAL

FR 12316

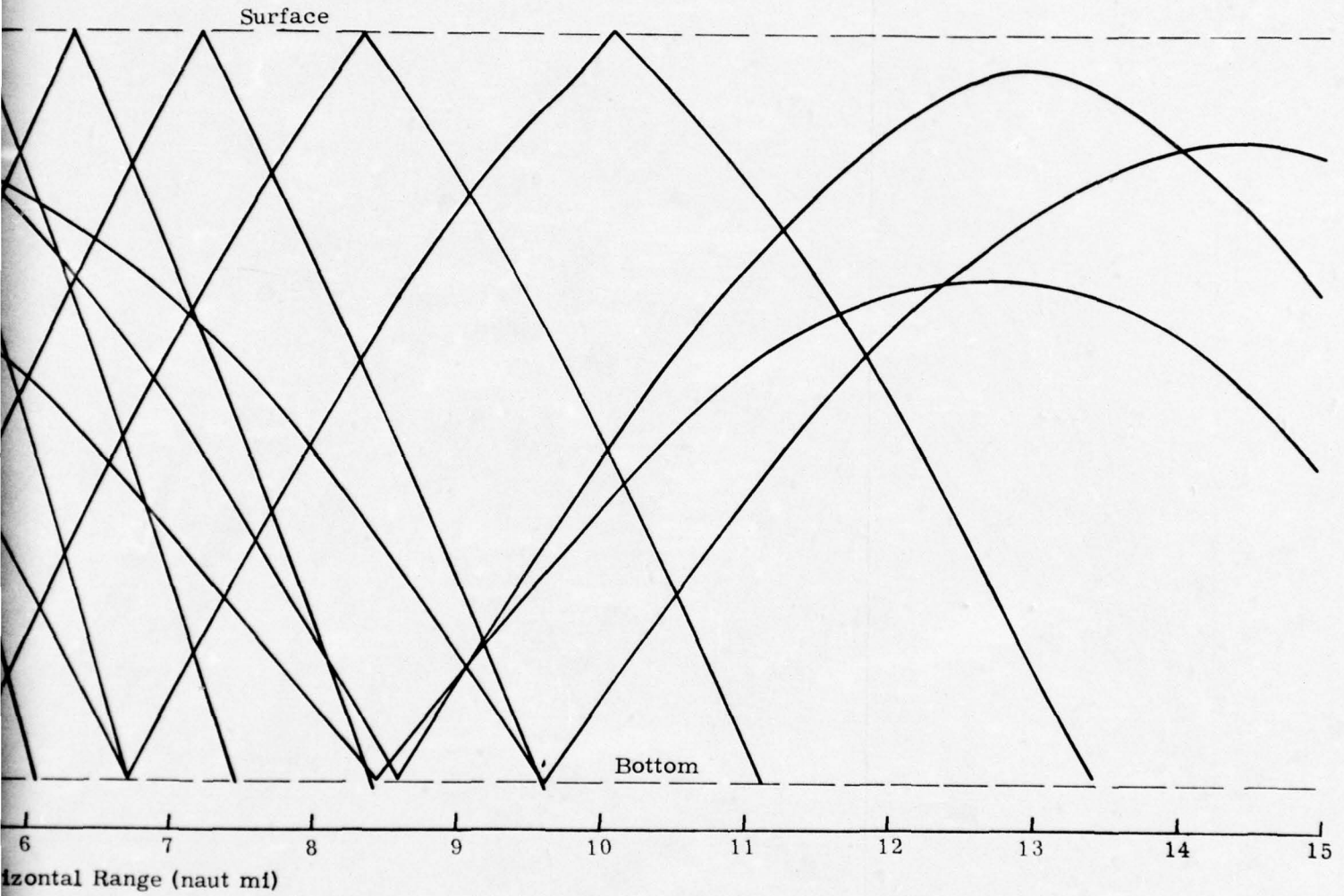
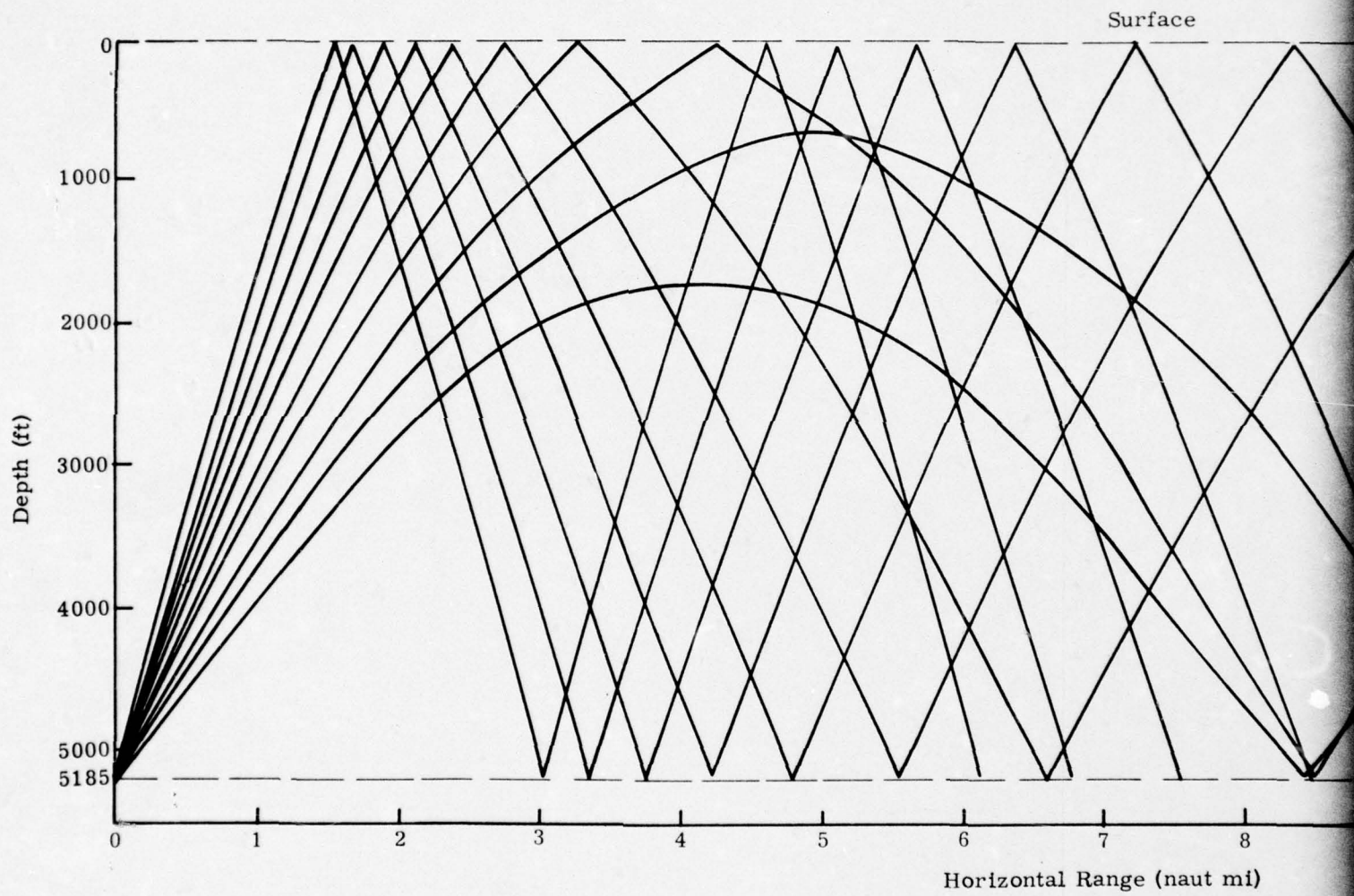

Fig. 27. Ray Path for Maximum Depth-Velocity Profile, Exuma Sound (source on bottom)

2



CONFIDENTIAL

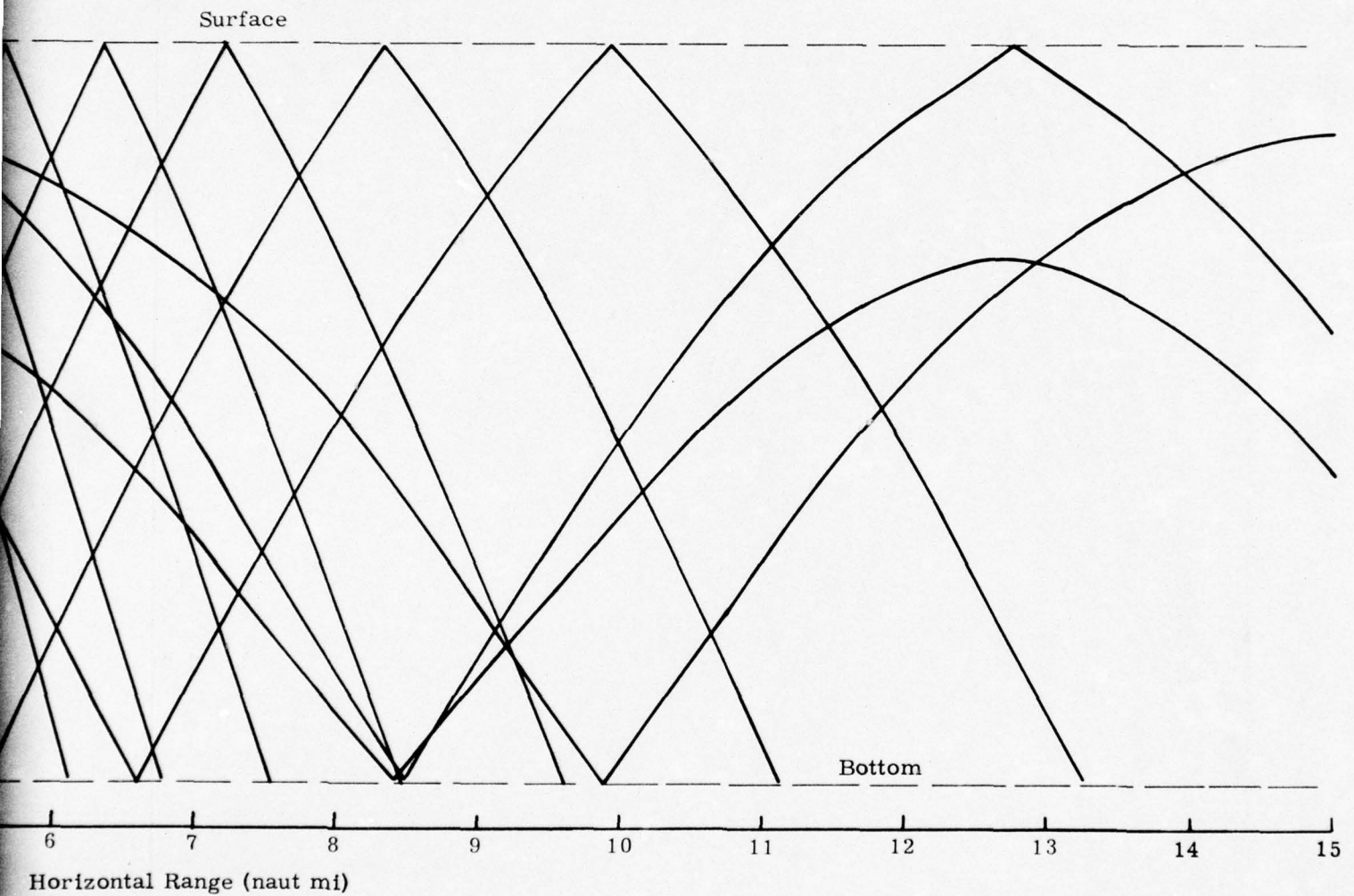

Fig. 28. Ray Path for Minimum Depth-Velocity Profile, Exuma Sound (source on bottom)

CONFIDENTIAL

ER 12316

2

obvious that there is sufficient information available to show that the direct system is feasible, whereas bottom bounce system suitability is considerably obscure.

One item to be considered is the effect that different depth-velocity profiles have on the average velocity of sound and the variation of path length. The average depth-velocity profile as well as the two extremes are shown in Fig. 29. The information shown is derived from data gathered by the University of Miami and the U. S. Hydrographic Office including the latest Hydrographic surveys in Exuma Sound, conducted late in 1961. The effect of these profiles is shown in Fig. 30. The variation over the 5-mi direct path is about  $\pm 15$  ft, while over a 15-mi bottom bounce path, the variation is about  $\pm 100$  ft or less, depending on the depth. This variation at 15 mi could possibly be neglected, but since a correction can be easily inserted into the computer on a seasonal, weekly, or even a daily basis (depending on the depth-velocity profile for that day), it is well worth the improved accuracy. Range errors due to depth-velocity profile variation are therefore no real problem.

The various arrival times of different propagation paths are shown in Fig. 31 for variations of up to 1400 ft after the desired signal. No undesired arrival occurs before the desired pulse, although many occur after it. The dead reckoning computer can be used to range gate the signal with as much leeway as  $\pm 2000$  ft about the estimated travel distance. The first pulse to arrive within this time is the correct pulse. The various arrival times are then no problem in either the direct or bottom bounce system.

The question of propagation loss and pulse degradation can be easily determined for the direct system. The propagation loss can be derived from the ray path diagrams and in any case is very close to spherical spreading. The pulse degradation is low over the direct path, and timing accuracies of better than 1 ms (5 ft) have been achieved many times in tests involving the Martin-BuShips Fixed Acoustic Buoy Array in Bermuda and the Martin-NUOS Taut Wire Array in the Tongue of the Ocean. On the other hand, since bottom loss and pulse degradation as a function of bottom bounce incidence angle and frequency were not known for the bottom bounce system, the experimental program described in earlier progress reports was embarked upon.

The results showed that AM and FM pulses were not degraded significantly (for the purposes of the navigational aid system) after two bottom bounces, and had sufficient short time stability. The Pseudo-random Pulse, however, had its pulse coding destroyed by multipath signals (in the simple postdetection integration employed) and, therefore, lost its main advantages, ease of station identification and elongation of

CONFIDENTIAL

the transmitted pulse. The use of true correlation can resolve the multipath signals and achieve the desired result with pseudorandom signals. However, the equipment (such as a DELTIC) is considered too expensive and too complex for the navigational aid system. The losses at the 15-mi range are not significantly greater than for the 5-mi direct path system. In fact, they are quite reasonable.

The results at this point are that the 15-mi range system, using up to one bottom bounce and with either AM or FM pulse coding, is feasible for the submarine navigation aid. The 15-mi bottom bounce system is preferred to the 5-mi range direct path system strictly because of cost, as will be shown later.

### 3. Frequency

There are basically four factors to consider when choosing the optimum frequency. These are propagation loss, submarine noise levels, mutual interference with other sonar systems and doppler effects. The effect of the latter depends on the coding and will be discussed under that subject.

The total propagation loss consists of spreading loss, bottom bounce loss and attenuation, the last two of which are frequency dependent. As discussed previously, the experimental program showed that the spreading losses were spherical to 5 mi and then cylindrical to 15 mi, which gives a maximum of 85 db spreading loss at 15 mi. Bottom bounce losses were found to agree closely with those of the SUAD report. Attenuation losses were neither significant nor measurable in the experimental program. Therefore, the attenuation losses are taken as a commonly used value of  $0.01 f^2$  db/kyd where  $f$  is in kc. The total propagation loss as a function of frequency is shown in Fig. 32 for the 15-mi range condition. Bottom losses as a function of frequency were taken from the SUAD data which is reproduced in Fig. 33.

The noise levels at the bow of the Shipjack at 25 kn were taken to be typical of high submarine self-noise (the Albacore has a self-noise that is 10 db lower in the range of interest for the same speed). The noise level as a function of frequency is shown in Fig. 34.

The combined effects of propagation loss and submarine noise as a function of frequency are shown in Fig. 35. The source level required for a 20-db signal-to-noise ratio and a 10-cps effective processing filter is plotted against frequency. What is important at this point is not the absolute values but at which frequency is the least power required. It is obvious from Fig. 35 that a frequency of 2 to 3 kc is optimum. Allowing a deviation of 6 db from optimum, to permit compromising with other factors, gives an acceptable frequency of between 1.4 and 7.5 kc.

CONFIDENTIAL  
ER 12316

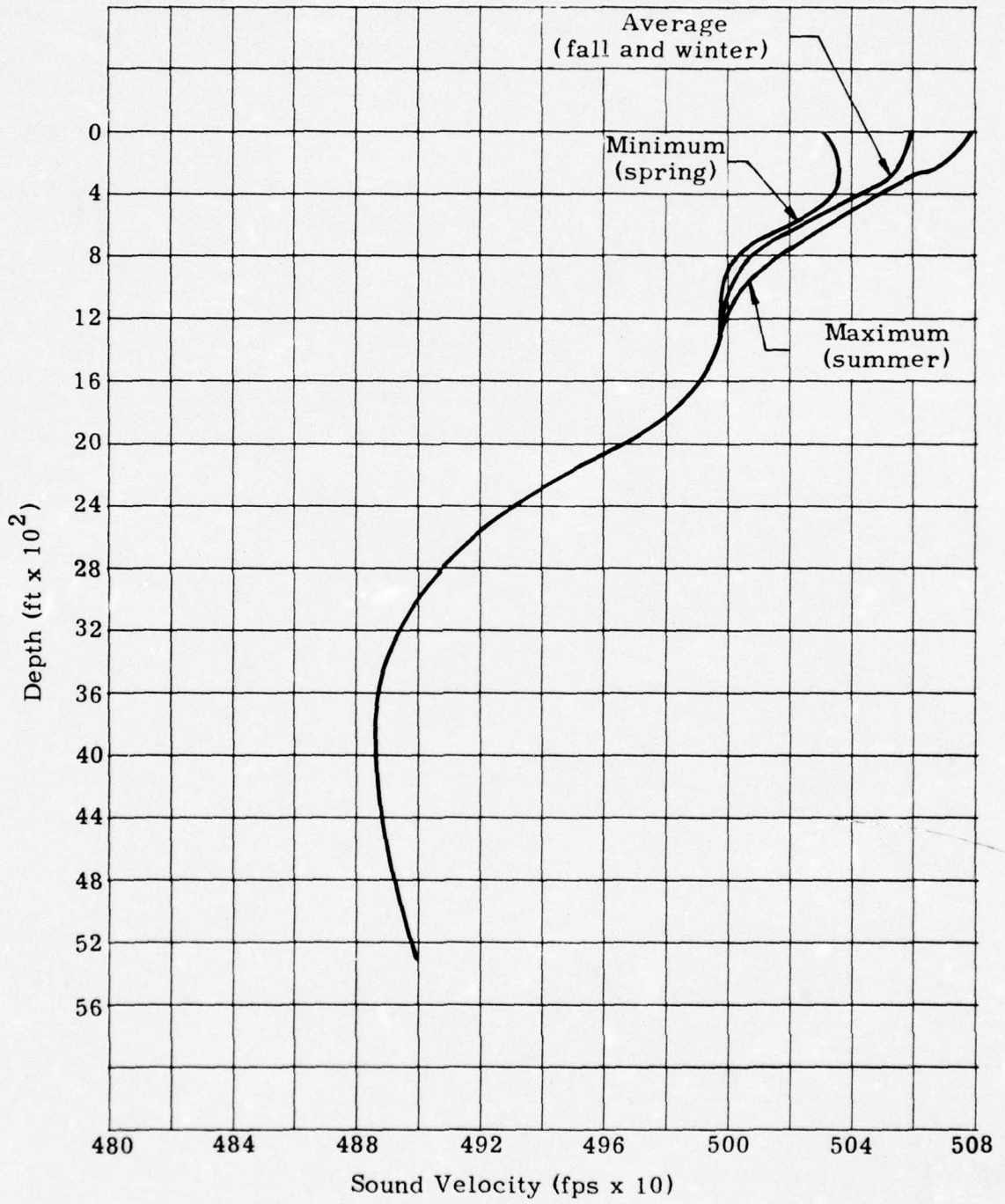

Fig. 29. Depth-Velocity Profile

CONFIDENTIAL

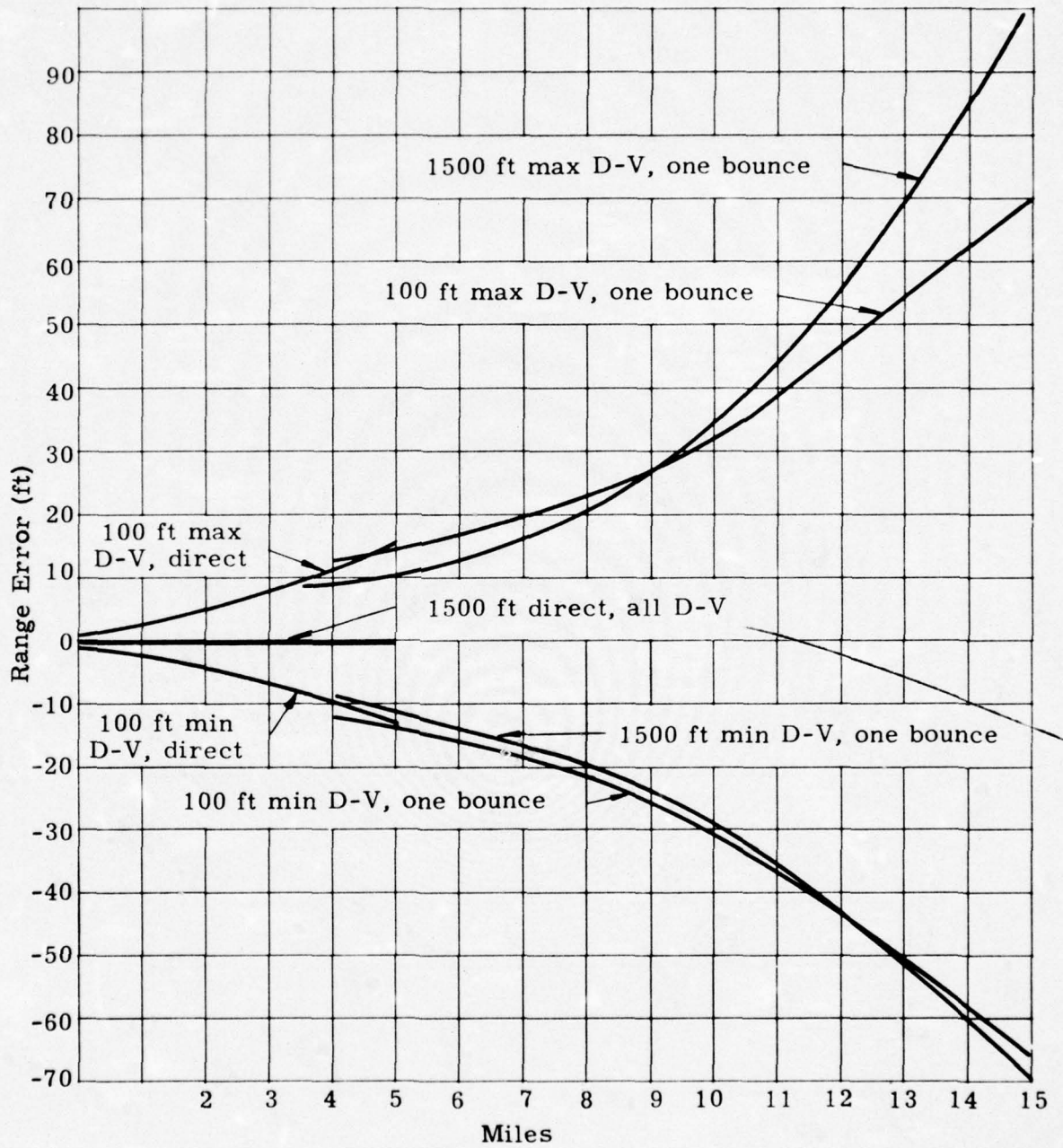

Fig. 30. Range Error as a Function of Depth-Velocity Profile

CONFIDENTIAL

ER 12316

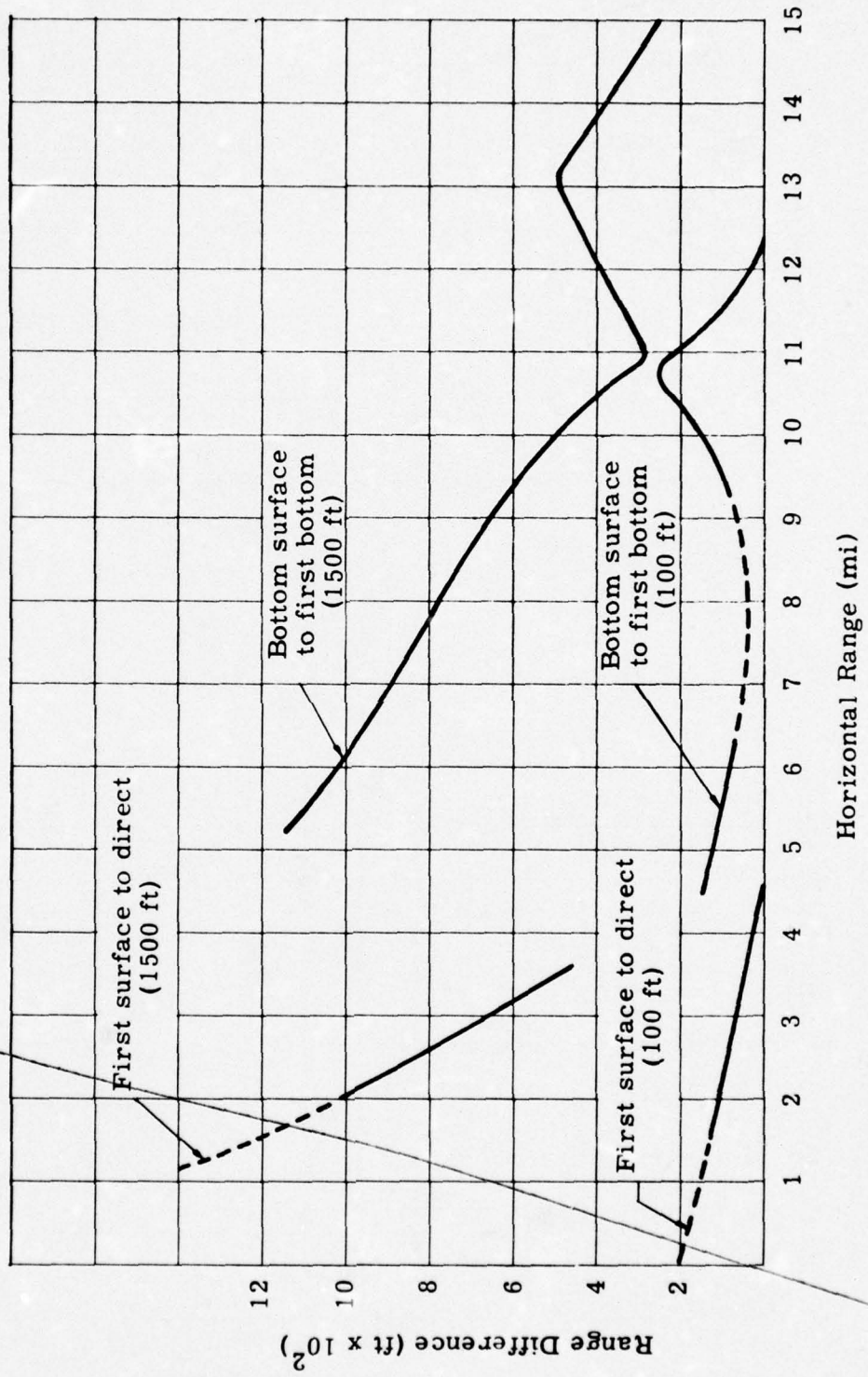

Fig. 31. Various Arrival Times Versus Range

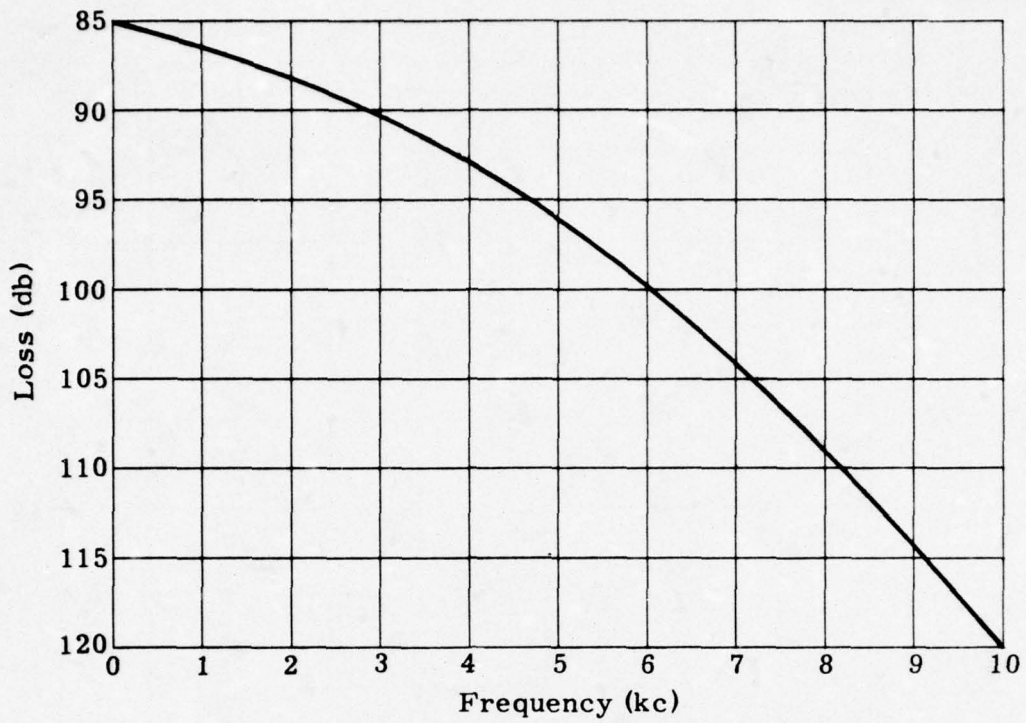

Fig. 32. Propagation Loss Versus Frequency, Exuma Sound (15-mile range)



Fig. 33. Bottom Loss as a Function of Grazing Angle

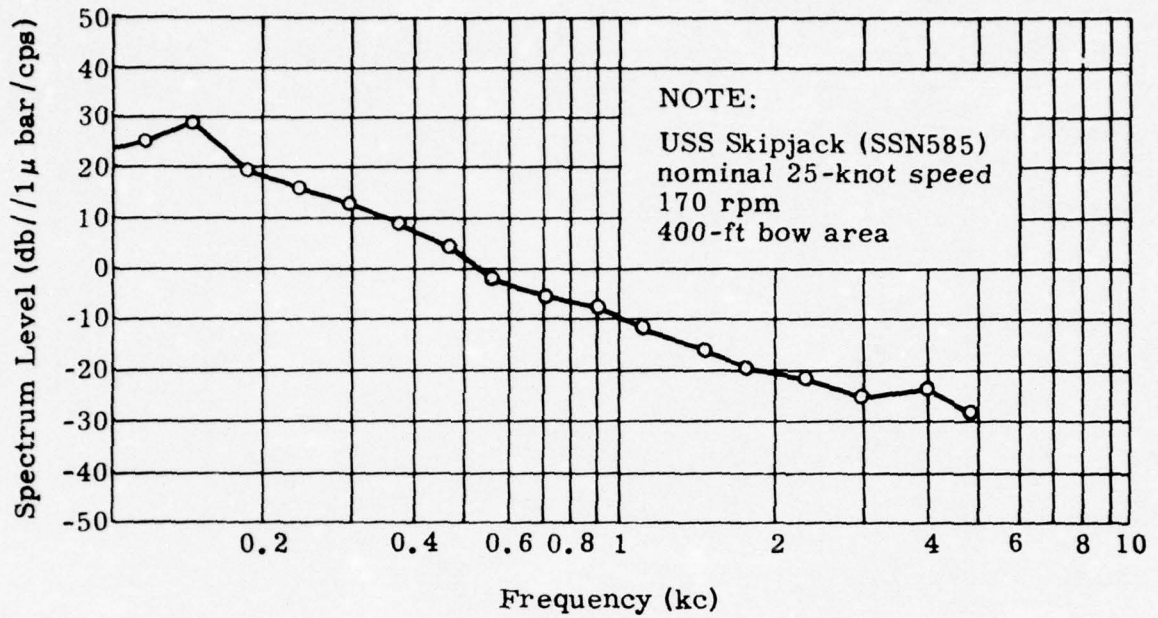

Fig. 34. Frequency Versus Spectrum Level

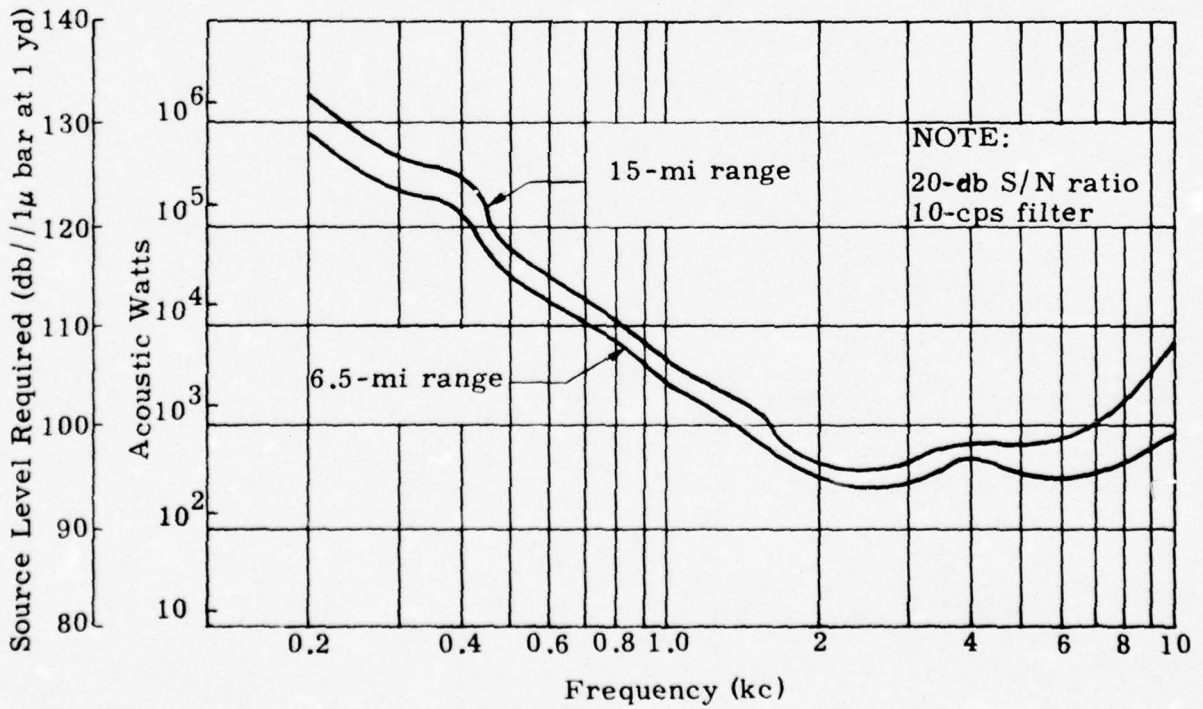

Fig. 35. Source Level Required Versus Frequency

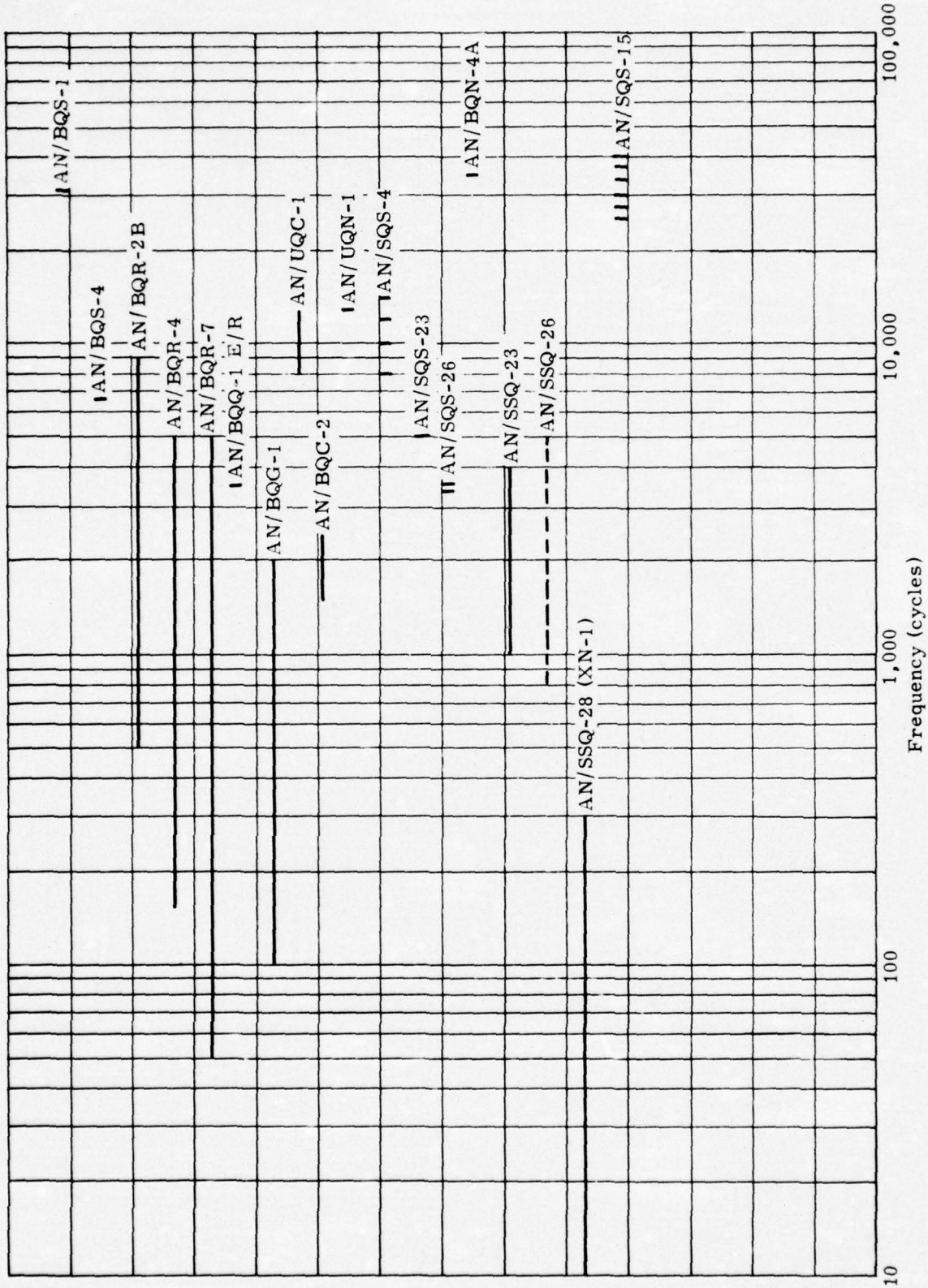

Fig. 36. Frequency Coverage -- Sonar Equipments

The frequency range of various sonar systems is shown in Fig. 36 from which it is apparent that active ship and submarine sonars occupy the region of 3.5 kc and above. It is also reasonably certain that future active sonars will not operate at any significantly lower frequency, due to size requirements of the sonar transducers arrays. To eliminate the mutual interference problems, the navigation aid system should operate below active sonar frequencies. This narrows the range of an acceptable frequency to between 1.4 and 3 kc. Many passive sonars operate in this range, and it is impossible to pick a frequency that will not be detected by passive sonars.

The interference effects on existing passive sonars can be separated into essentially four categories, depending on the type of passive signal processing used. These are:

- (1) Narrow band frequency analysis.
- (2) Wide band, long term averaging.
- (3) Wide band, short term averaging.
- (4) Specific system effects.

The effect of the system on each of these is described in more detail in the following discussions.

a. Narrow band frequency analysis

In this type of processing, a large number of comb filters is used directly on the signal, or a fast scanning filter is used on a replica of the signal. In either case, a line spectra of the received noise is made. The filters are narrow and, therefore, have a medium integrating time constant. This time constant is on the order of 1 to 0.1 sec, and is in a range that will allow some portion of the navigation signal to get through.

Postdetection integration is used by either the addition of long time constant integrators (on the order of 10 sec or more) and by visual observations on paper recorders. In the first case (electronic post-detection integration), none of the three pulse modulation systems considered would interfere with the operation of the passive system. In the second case (visual postdetection integration), the pulses would be discernible since the signal-to-noise ratio will be very high in many instances.

To minimize or eliminate the interference, the pulse amplitude should be kept as low as possible and the bandwidth as large as possible. This condition can be met to some extent with an AM pulse since narrowing the pulse period increases the bandwidth, but this in turn requires a

CONFIDENTIAL

higher peak power for a given pulse energy and, therefore, for a given signal-to-noise-ratio. The interference situation improves as this is done, but only at a slow rate because as the bandwidth is doubled (giving about one-half the energy in a given band) the power output has to be doubled, bringing the energy in the given band back to about the initial level. The reason that the AM pulse still offers improvement is that only the first 10 to 20 ms of the pulse are important to this application (because of timing accuracy considerations) and until the width is decreased significantly below those values, the situation can be improved.

On the other hand, FM and pseudorandom modulation can simultaneously be arranged to give a wider bandwidth and amplitude for the same pulse energy. For instance, doubling the bandwidth would decrease the energy in a given band by one-half. The pulsewidth could be simultaneously doubled and the amplitude cut in half (giving the same pulse energy) to decrease the energy in the given band by another one-half, or a total of one-fourth. The range resolution of the system would actually stay the same under the above manipulations. The price paid, of course, is double the complexity in the modulating and demodulating portions of the system. Thus, to minimize interference in a passive system using narrow band processing requires the navigation signal pulse to have a wide bandwidth and a low amplitude.

b. Wide band, long term averaging

This type of processing utilizes a long integration time (tens of seconds to a minute, or more) over the band of interest and a comparison is made with either previous noise averages or to noise averages from other directions. In this case, the energy in the navigation pulse is all that matters from an interference viewpoint (assuming the passive bandwidth encompasses the total pulse bandwidth) and should be minimized. This is directly opposed to the navigation system requirements. There is still a fair degree of compatibility, however, since the long averaging times will essentially decrease the effect of the navigation signal by the duty cycle of the signal, which gives a rejection of 20 to 40 db, or more. Passive equipment also has a much wider frequency band than that of interest to the navigation system (which is approximately 1/2 of an octave and helps to limit the interference). This is especially true when the passive equipment extends to the lower frequencies where the noise level is greater. Thus, the methods of minimizing interference in a passive system using wide band, long term averaging are to use minimum average energy (low duty cycle and minimum pulse energy), and higher frequencies.

c. Wide band, short term averaging

In systems using signal processing of this type, the information is either displayed visually or monitored aurally. In either case, the pulse energy should be minimized and spread out over as long a time as

CONFIDENTIAL  
ER 12316

possible to decrease the instantaneous signal-to-noise ratio. Again, wider and lower passive system bandwidth helps to hide the navigation signals.

Random or pseudorandom repetition rates can be used to disguise the signals, particularly on the visual display, so that no periodicity may be noticed and the signal appears as a random noise burst. This may help only slightly in the aural case, since all three types of modulation are easily picked by the most versatile signal processor: the human ear and brain combination. One possible method of hiding this signal from the ear is to use the same sample of thermal noise centered at two different frequencies as the transmitted signal. This was originally considered for use with the SPUME system and gives a signal which sounds and looks like a noise burst. However, this is not considered necessary.

d. Specific system effects

The Submarine Sonar Branch of USNUSL was contacted in order to gain a better insight into the interference problem and to learn the design details of these various passive systems. This group was the original design specification group for the equipment in question. The following information was determined:

- (1) The most susceptible circuitry of the passive systems is the ATF (Automatic Target Following) used to give fire control tracking information.
- (2) The time constants of these circuits varies from 70 ms at high signal-to-noise ratios to 250 ms at low signal-to-noise ratios.
- (3) Any signal that approximates in length or is longer than the above time constants, and falls somewhere near the ATF passband, will interfere with the ATF equipment action. Amount of interference will, of course, depend upon signal level relative to target noise level.
- (4) The ATF passbands (3-db down points) are:
  - (a) AN/BQR-2B            5 to 10 kc
  - (b) AN/BQR-7            0.5 to 1.4 kc low speed (own ship)  
                                 1.0 to 2.0 kc high speed (own ship)
  - (c) AN/BQS-6 (passive) 3 to 4 kc (estimated)

CONFIDENTIAL

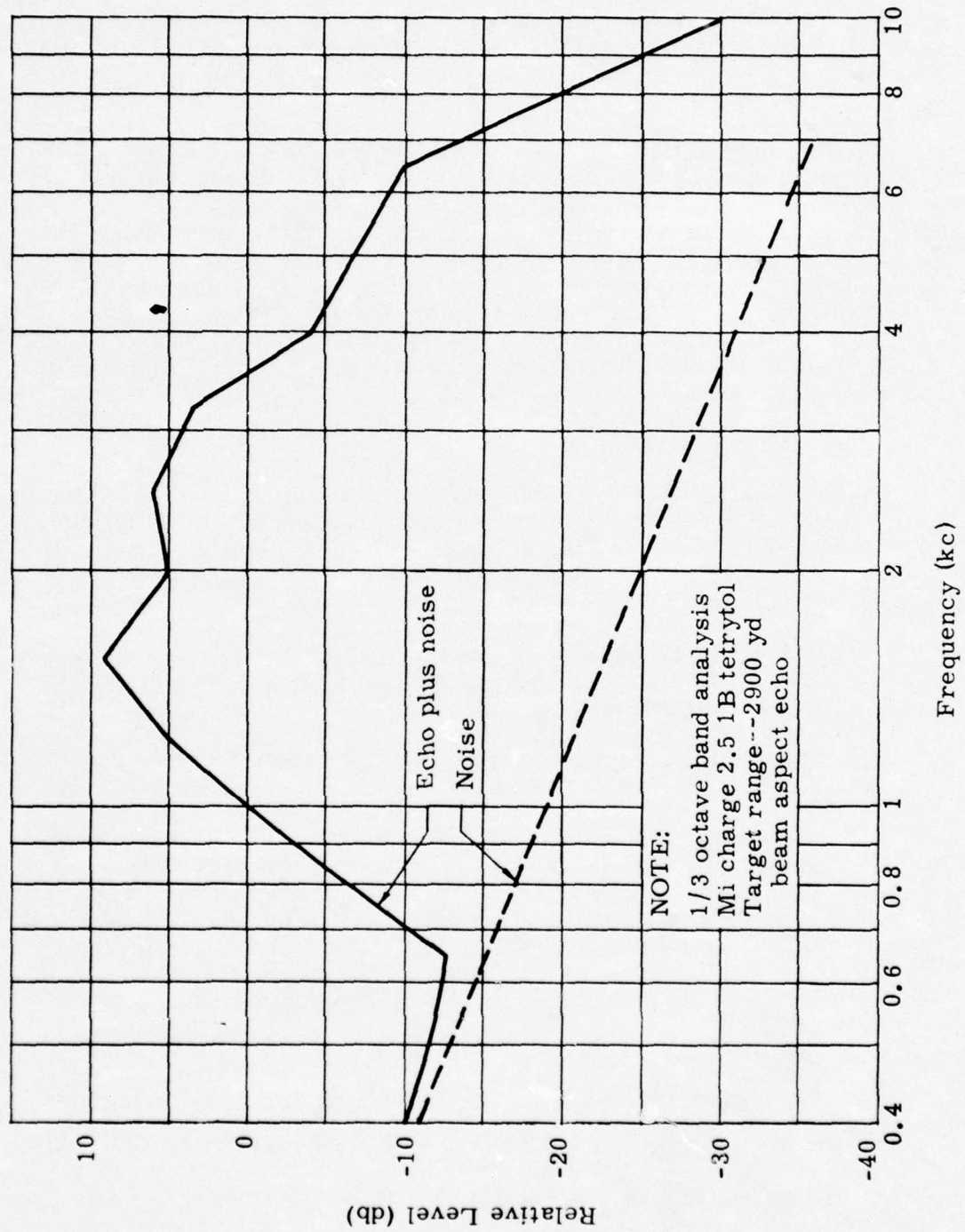

Fig. 37. Typical Echo and Noise Spectrum

CONFIDENTIAL  
ER 12316

- (5) The interference will be in the form of an error introduced in the overall fire control solution.
- (6) The recorder passbands are:
  - (a) AN/BQR-2                    1 to 4 kc  
    5 to 10 kc
  - (b) AN/BQR-7                    0.5 to 2 kc
  - (c) AN/BQR-4 A/RO-7    0.6 to 4.8 kc
- (7) The audio, or direct listening, circuitry of the different equipments can select different upper and lower cutoff frequencies. An operator listening in the correct band would be able to distinguish the signals that are on the order of 100 ms or longer.
- (8) Based on the above, it is apparent that the short AM pulses would give the least interference. The longer or PRN pulses are expected to be readily noticed.

The saving grace here is that passive sonars use correlators and/or postdetection integration with effectively long integration times. Therefore, the visual display will not be detrimentally affected by the relatively short pulses and low repetition rates that will be used in this system. The navigation signals will be heard aurally, but again will not affect the performance of the passive sonar.

There are two other systems that have possible mutual interference problems in this frequency range. One is SESCO and the other is E<sup>2</sup>R. The Navaid will not interfere with SESCO because its short pulse modulation and low repetition rate will not have any effect after passing through the wide band, long averaging time correlation used in the SESCO receiver. The SESCO transmission, on the other hand, will possibly blank out the receipt of the Navaid pulse, depending on the amount of feedthrough from the SESCO projector to the bow hydrophone or hydrophones being used for reception of the Navaid signal. At worst, all that can happen is that the navigation signal will be lost during SESCO transmission and the submarine position will have to be computed by dead reckoning during this period. This is not considered a serious interference problem.

E<sup>2</sup>R employs charges that result in an echo frequency spectrum as shown in Fig. 37. As shown in the figure, the spectrum of interest is 700 cps to 10 kc, which completely covers the 1.5 to 3 kc satisfactory region of operation for the Navaid system. Obviously, the Navaid signals will be heard on the E<sup>2</sup>R sonobuoys and the noise from the charges will

CONFIDENTIAL

be received by the Navaid system. In the former case, little interference will result since the Navaid signal is not similar at all to an explosive echo and will be easily recognized by a Julie operator. There will be a finite probability that a strong Navaid signal may be received simultaneously with a target return and prevent or at least confuse the recognition of the target echo. This probability is extremely low, however, as the pulse lengths of the Navaid and especially the explosive echo are short and the repetition rates of both signals are very low. The explosive signal will possibly (depending on the range to the submarine and the Navaid pulse coding) give a false range and position. The Navaid computer will reject this false range and position information in all cases except when the false information is close to being correct. This will also occur with a low probability and is not too serious when it does happen.

The conclusions that are reached after consideration of all the above factors are:

- (1) A frequency for the operation of the Navaid cannot be chosen to eliminate all mutual interference and still permit reasonable system design.
- (2) Operation of the Navaid in the optimum 2- to 3-kc frequency will result in mutual interference systems. However, this will not significantly affect the performance of other sonar systems and will only occasionally and temporarily affect the Navaid system.
- (3) The Navaid system should operate in its optimum range of 2 to 3 kc.

#### 4. Bandwidth

Two factors affect the determination system bandwidth. The first is the range resolution required and the second is the number of different operating bands necessary to permit station identification and to prevent interstation interference. The second factor is independent of the first and is a function of the method station identification. It will be discussed later under that subject.

The range resolution desired in a Navaid with a 150-ft accuracy would normally be one-tenth the accuracy value, or 15 ft. The reasons for this are to let the resolution contribute negligible error, to allow more consistent position determination and to permit more accurate station keeping. Since bandwidth increases as the resolution is improved, this may be too stringent a requirement and a resolution of one-third, or 50 ft, is about the acceptable limit. Improving the resolution to a value smaller than 15 ft would contribute little to the system accuracy. Therefore, the acceptable range resolution for this Navaid system is between 15 and 50 ft.

CONFIDENTIAL  
ER 12316

The bandwidth required for a given resolution is the same, regardless of the coding system used, and increases as the resolution is improved as shown in Fig. 38. The resulting bandwidth is between 100 and 340 cps corresponding to a resolution of 50 to 15 ft. Taking a geometric mean of the resolution limits gives a compromise of approximately a 25-ft resolution and a 200-cps bandwidth. Of course, these values can be varied up or down somewhat, but it is a good compromise in that doppler causes an increase in bandwidth of 100 cps in any case so that only 50% more total bandwidth is required to halve the range resolution from 50 to 25 ft.

### 5. Pulse Coding

Early in the study it was determined that the modulation should be of pulse form, since continuous transmission would clutter up the frequency band of interest continuously and fairly complicated coding would be required to get unambiguous range. Also, multipath signals would make selection of the correct arrival almost impossible.

Three pulse modulation types were considered: AM, PR (pseudo-random) and FM (linearly swept in frequency). AM is the simplest and, therefore, highly desirable from that point of view. The AM pulse coding performed in a satisfactory manner during the experimental tests. The only drawback (a serious one) is that the optimum AM pulse is narrow for the range resolution required and needs a correspondingly high peak power (Fig. 39). A resolution of 25 ft requires a 5-ms pulse, with a peak power of 5000 acoustic watts for a 20-db signal-to-noise ratio. A 10-bit length PR pulse, or an FM pulse (with 20-cps filters) requires only 500 acoustic watts peak, which considerably eases the requirements on the pulse driver and acoustic projector even though the pulse length is increased to 50 ms. The PR pulse has the additional attribute in that it can be used to identify the various stations conveniently within the same bandwidth. The choice then narrows to that of either PR or FM pulse. The two modulations have inherently the same characteristics as far as resolution, multipath rejection, peak power and pulse length are concerned. To achieve these characteristics, the PR signal requires use of digital correlation techniques, while the FM can use either digital or one of several analog techniques. The optimum PR processing requires a Deltic type correlator which was ruled out as being too complex and costly for the Navaid computer. A less sophisticated and considerably simpler technique of postdetection integration was contemplated since the input signal-to-noise ratio was sufficiently greater than one at the detector input. Tests with PR pulses during the experimental program showed that this technique would not work properly in the presence of multipath signals, which exist in abundance in the Navaid system. Thus, the PR pulse was ruled out.

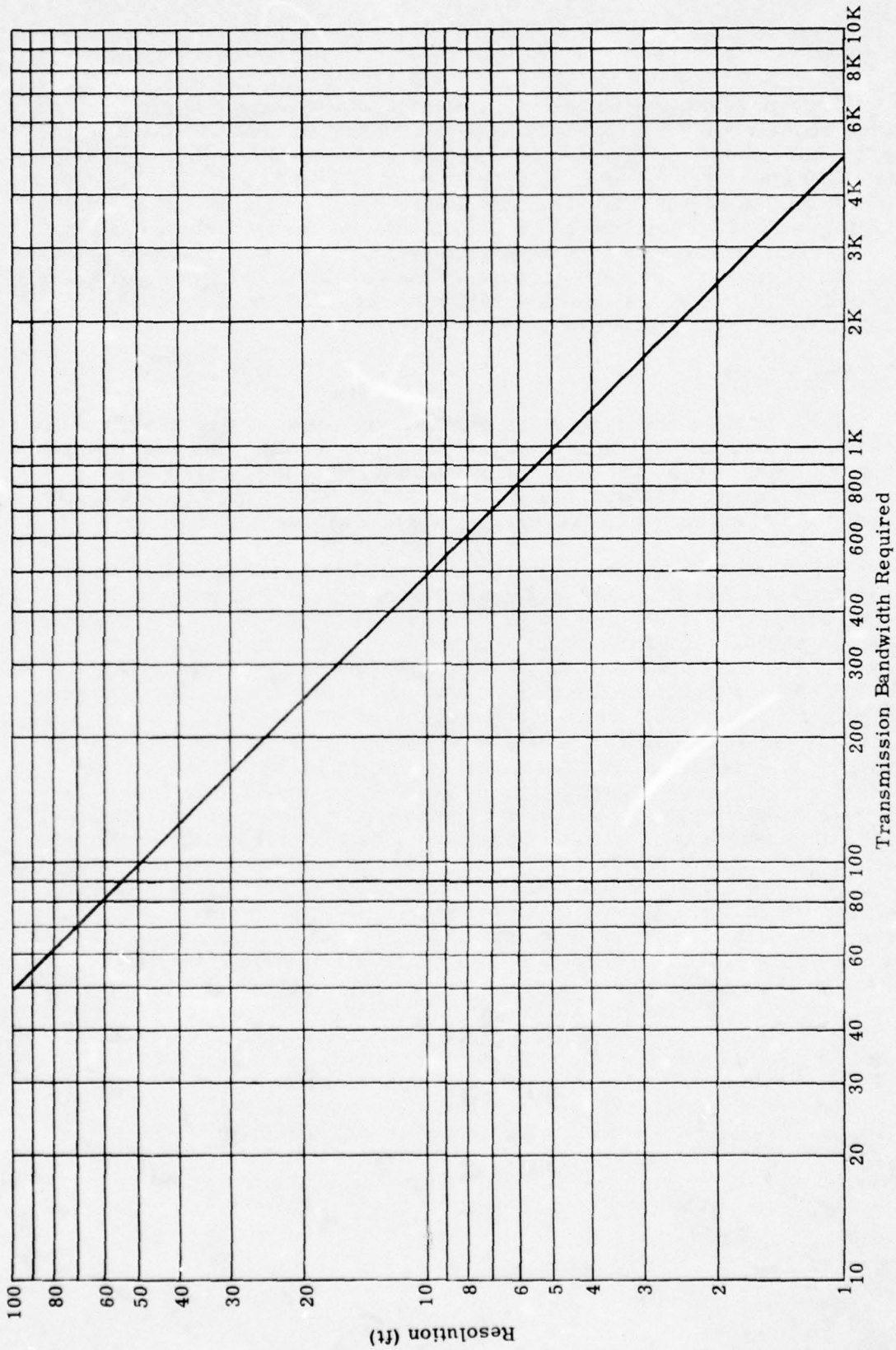

Fig. 38. Transmission BW Versus Range Resolution, AM, PR and FM Coding

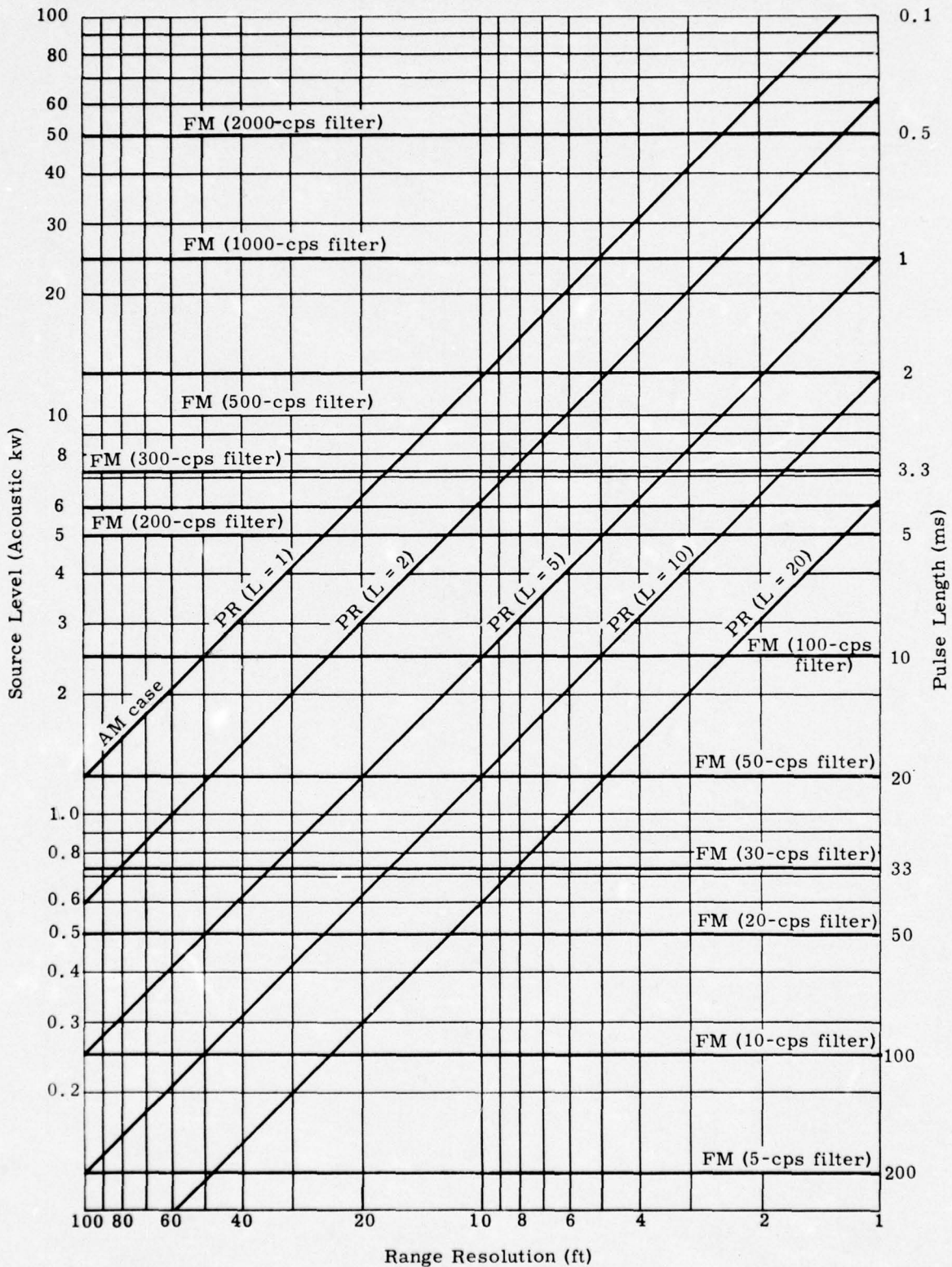

Fig. 39. Pulsewidth and 2.5-kc Source Level Required Versus Range Resolution for a 20-db S/N Ratio at the Output

CONFIDENTIAL

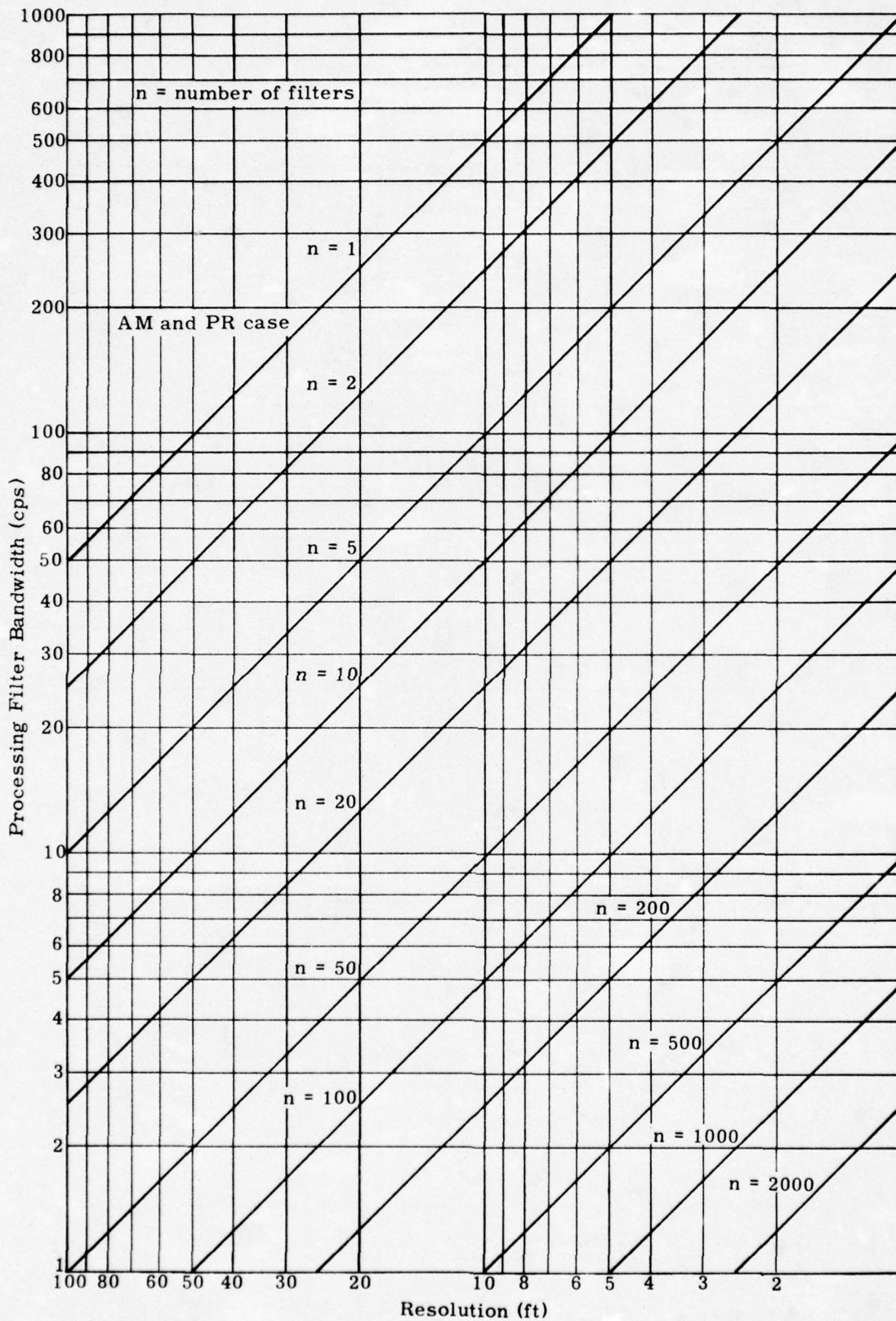

Fig. 40. Number of Filters Versus Resolution and Filter Bandwidth

CONFIDENTIAL

ER 12316

This leaves the FM pulse which can be processed by the relatively simple analog means of subtracting (in frequency) an FM pulse replica from the incoming signal and analyzing the difference frequency in a bank of comb filters. The acoustic power level required depends on the filter bandwidth as shown in Fig. 39. A 30-cps filter requires 730 acoustic watts at the transmitter, a 20-cps filter requires 500 watts and a 10-cps filter requires 250 watts. The corresponding pulse lengths are 33, 50 and 100 ms. The number of filters required in the FM system is a function of the resolution required and the processing filter bandwidth (Fig. 40). A 25-ft resolution system requires 20, 10 and 7 filters for processing filter bandwidths of 10, 20 and 30 cps, respectively.

Doppler effects have to be considered when choosing the filter bandwidths. Two effects are produced by doppler acting on an FM pulse. One effect is to shift the center frequency and the other is to change the apparent rate (or slope) of the frequency shift. The first effect amounts to 50 cps for a 30-kn submarine when a 2.5-kc frequency is used. This effect amounts to a shift of 5, 2.5 or 2 filters for a 20-, 10- or 7-cps wide processing bandwidth, respectively, for a 25-ft resolution system. Translated into range, this gives errors of 125, 63 and 50 ft, respectively, which are too large to neglect and should be compensated for in the navigation computer. The second effect is proportional to the FM sweep width, which is 200 cps for a 25-ft resolution system. This is less than one-tenth the first effect, and amounts to shifts in range during the pulse reception time of 5, 10 and 14 ft, respectively, for the three previously mentioned examples. This error is considered negligible since it is less than the 25-ft resolution.

What is desired (for a given resolution) is a narrow bandwidth to minimize transmitter power requirements, a wide bandwidth to decrease pulse length (and therefore minimize interference), a wide bandwidth to minimize the number of filters required and a wide bandwidth to decrease doppler effects. A reasonable compromise is to use a 20-cps filter which requires 10 filters, and a 50-ms transmitter pulse of 500 acoustic watts peak power.

#### 6. Repetition Rate

Submarine position will be continuously computed by a dead reckoning-type computer which is corrected by the sonar data, as stated previously. The repetition rate required is a function of dead reckoning error buildup with time.

Three basic sources of errors are involved in the dead reckoning computer. These are errors in the input parameters, errors due to water currents and integrator drift errors. The input errors are generally on the order of  $\pm 0.1^\circ$  in heading and  $\pm 0.1$  kn. At 30 kn (50 fps),

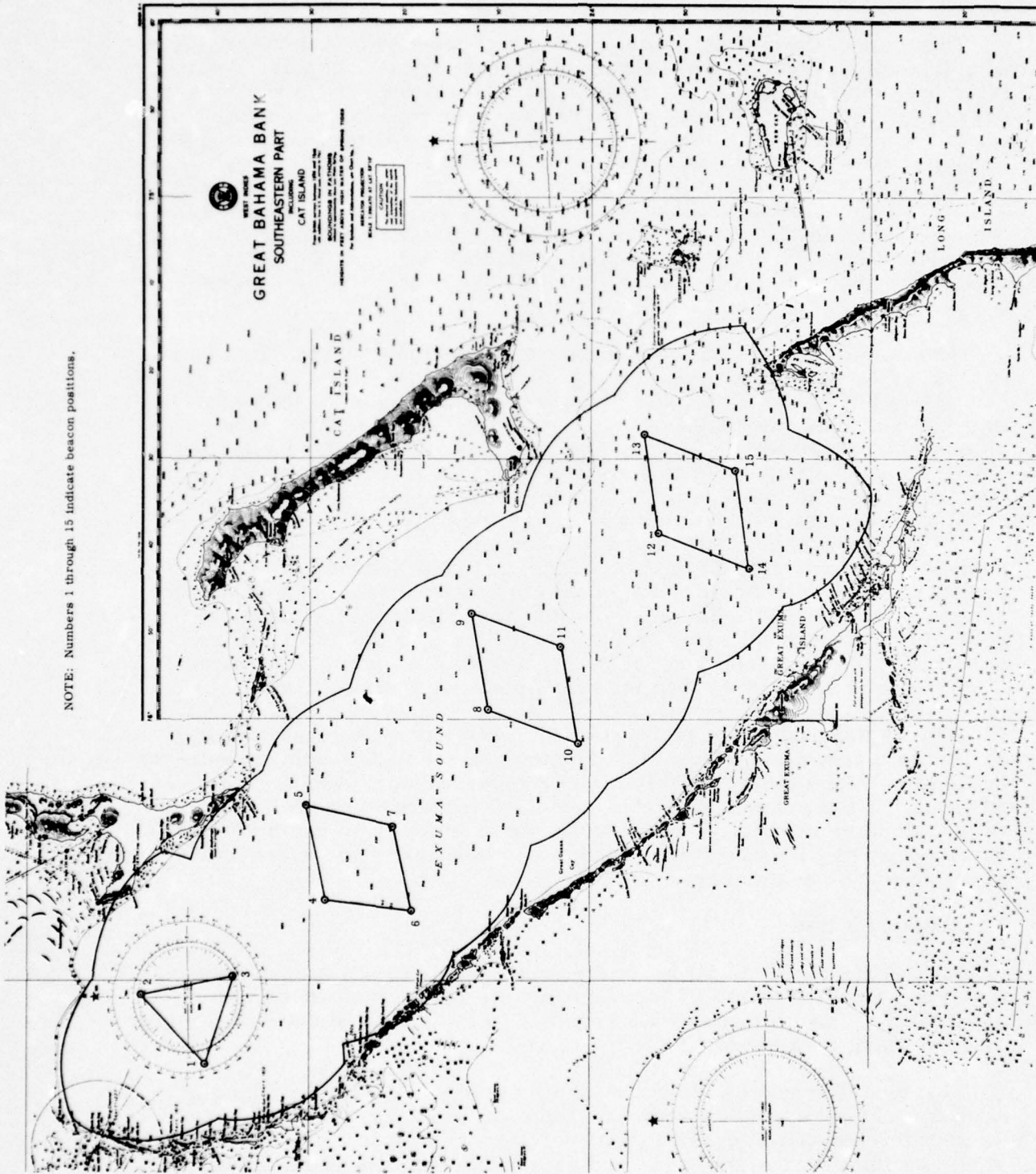

Fig. 41. Coverage of 2809 Square Miles Provided by 15 Beacons (84.4% of total area)

this amounts to position errors of approximately 0.1 fps and 0.2 fps, respectively. These are both negligible compared to the error introduced by a 1-kn current, which gives a 1.7-fps error. The 1-kn current is a typical value that can be expected near the surface. The integrator drift depends on the hardware components being used, but a value of  $\pm 0.1\%$  of full scale input is typical. Assuming a 30-kn full scale input value gives a 0.05-fps position error. Therefore, all the errors of the dead reckoning computer are small compared to the drift error of 1.7 fps.

The total drift error should be less than 1/3 of the accuracy desired or about 50 ft, so as to contribute negligible error. Since a repetition rate of one pulse every 30 sec would give a 50-ft error due to drift, no lower repetition rate should be considered. Another factor that influences repetition rate is the desirability of unambiguous range from each beacon. Since the range will be as much as 15 mi (91,000 ft), a travel time on the order of 19 sec will be encountered. This means that the repetition rate should not be less than once every 19 sec. Therefore, the repetition rate should be between once every 19 sec and once every 30 sec.

The repetition rate is derived from a standard clock and for convenience it should be an integral factor of 60 sec. Since the factors of 60 are 1, 2, 3 and 5, the choice of repetition rates are once every 1, 2, 3, 4, 5, 6, 10, 12, 15, 20, 30 or 60 sec. The choice, due to the previous factors, is then limited to once every 20 or 30 sec. A repetition rate of once every 20 sec would appear to be more favorable, due to the fact that the navigation position is computed more often. However, once every 30 sec is necessary to prevent interstation interference.

#### 7. Beacon Placement

Fifteen beacons are preferred over the 20-station configuration, since it is more easily expandable and covers most of the area (84%) with the minimum number of beacons (Fig. 41). Additional beacons can then be easily added at any time to increase coverage to 100%.

The beacon placement is basically a group of diamond patterns consisting of four beacons (except for the extreme northern end) giving a total of 15 beacons as shown. The positions for these beacons are:

<u>Station No.</u>	<u>North Latitude</u>	<u>West Longitude</u>
1	24° 47' 30"	76° 31' 30"
2	24° 41' 00"	76° 40' 00"
3	24° 38' 00"	76° 29' 00"

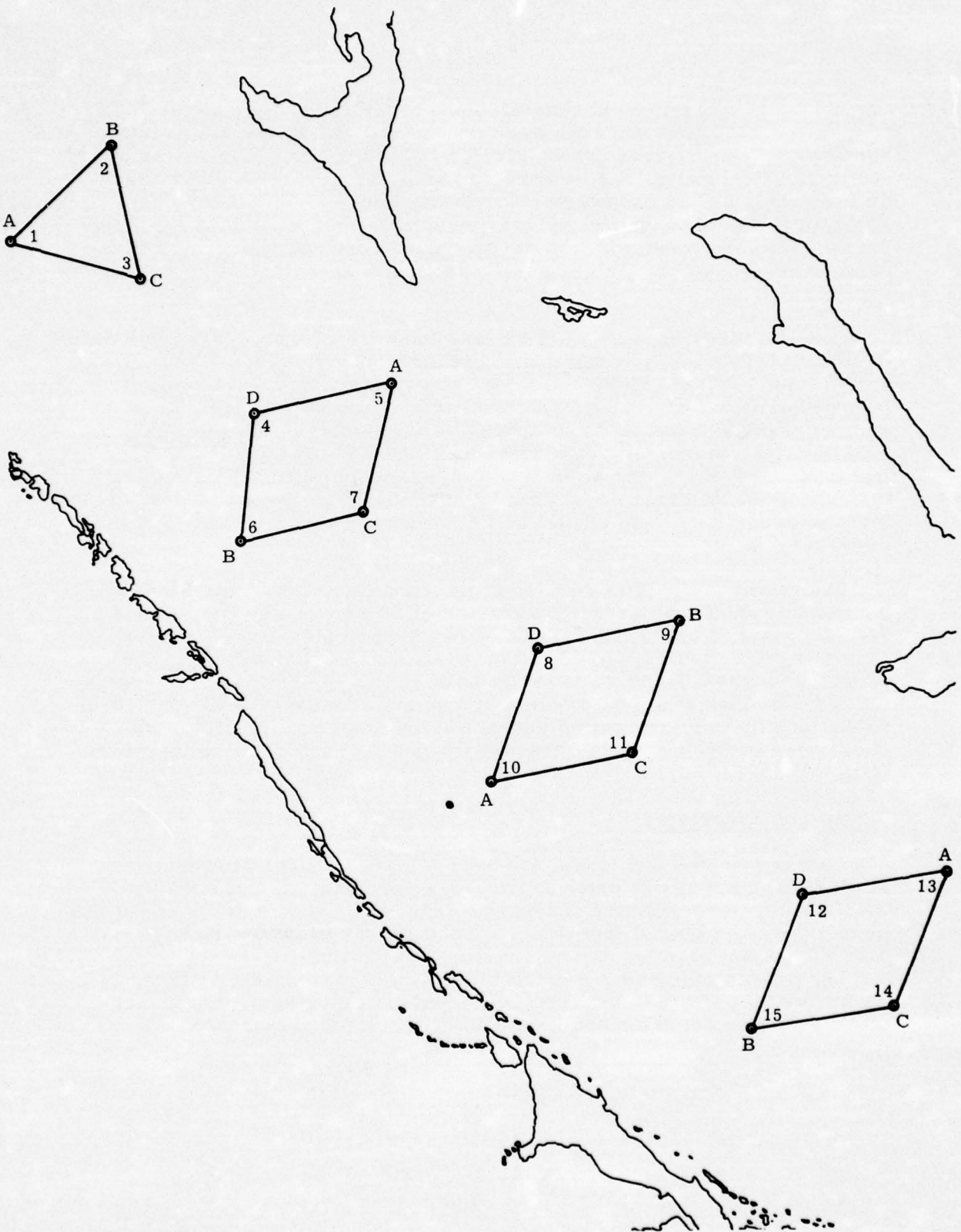

Fig. 42. Placement of Various Coded Beacons

<u>Station No.</u>	<u>North Latitude</u>	<u>West Longitude</u>
4	24° 30' 30"	76° 10' 00"
5	24° 28' 30"	76° 20' 00"
6	24° 20' 00"	76° 22' 00"
7	24° 21' 30"	76° 12' 00"
8	24° 12' 00"	75° 59' 00"
9	24° 15' 00"	75° 48' 30"
10	24° 02' 00"	76° 01' 45"
11	24° 05' 30"	75° 51' 30"
12	23° 52' 30"	75° 41' 30"
13	23° 54' 30"	75° 31' 30"
14	23° 43' 00"	75° 45' 30"
15	23° 45' 00"	75° 35' 00"

#### 8. Beacon Identification

Ideally, each beacon should be individually coded but since each beacon requires a 300-cps bandwidth, this would prove to be impossible. On the other hand, the dead reckoning computer calculates the submarine position continuously, and, therefore, can tell which beacons are being received when. Of course, when two beacons are received at approximately the same time, the dead reckoning computer doesn't have enough accuracy to determine the particular station that a given signal belongs to, if all signals are the same type. This means that at least two distinct identification codes are required. However, as a submarine proceeds through Exuma Sound, two stations of the same identification would be encountered frequently with only two different codes available. This could be alleviated by having three codes, but there are still cases (when the submarine is on a base line between two stations) when two stations of the same code would be required to give an accurate position. This happens less frequently than with the one or two code systems, but still would be a fairly common occurrence. Therefore, a minimum of four separate codes, A, B, C and D, are required (Fig. 42). The coding is such that the two beacons of the same coding are a minimum of 25 mi apart, and there is never a need to use two beacons of the same coding in determining position.

Since a 200-cps bandwidth is required, plus 100 cps (due to doppler effects) for each different coding (if they are coded differently by a frequency separation only), an excess of 1.2 kc total bandwidth is required for the Navaid system. This is a fair amount of bandwidth, and,

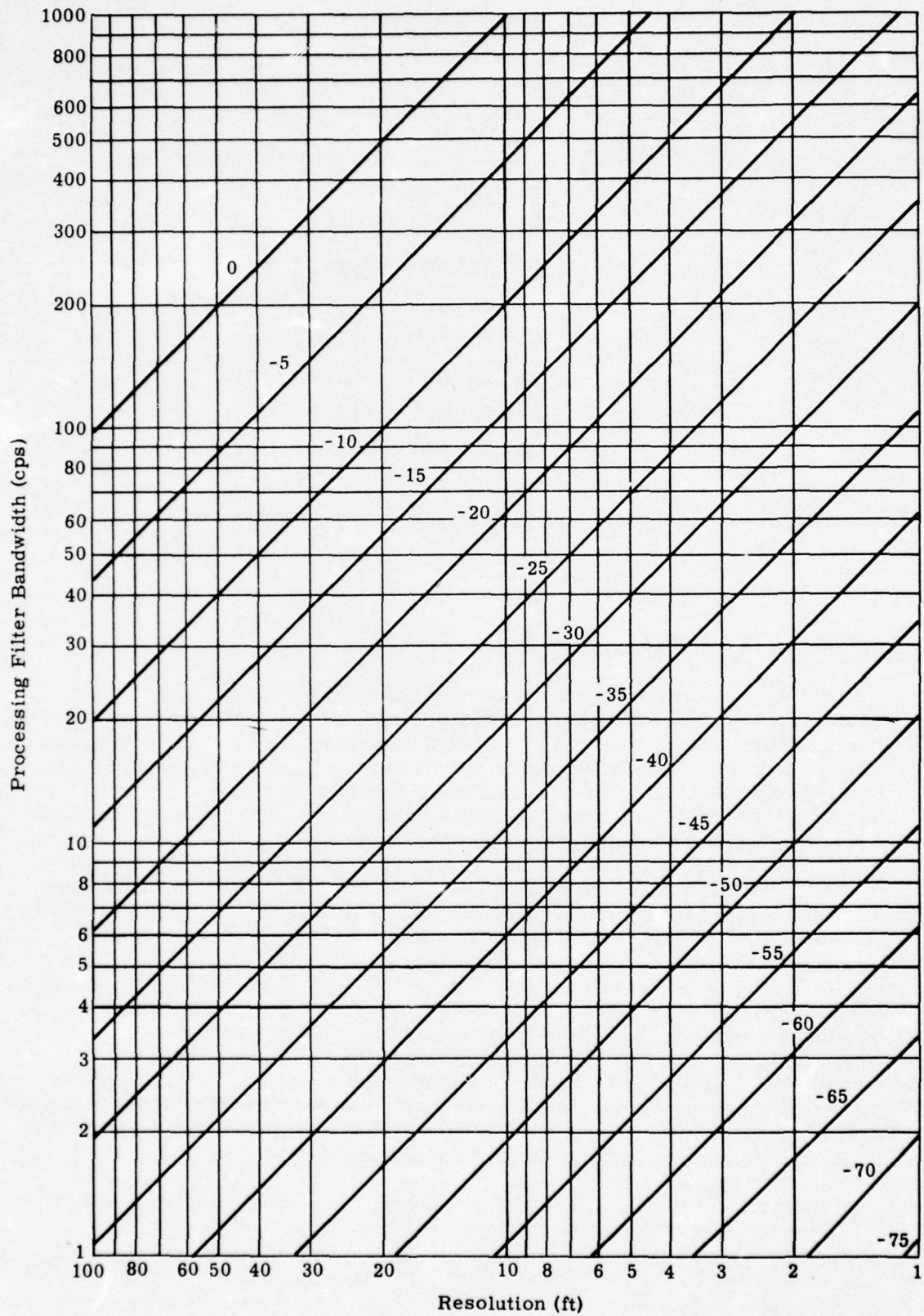

Fig. 43. FM Pulse Rejection

while it is possible to use this much, the requirement can be cut in half. This can be accomplished by sweeping the frequency of one station with an ascending frequency and sweeping the frequency of opposite stations with a descending frequency. This means that only two frequency bands are required for four different codings. Only 700 cps of receiving bandwidth and 600 cps of transmitting bandwidth are required if a 100-cps guard band is inserted between the two received bands. The bands chosen for transmission are 1.9 to 2.1 kc and 2.3 to 2.5 kc, since these are in the optimum frequency range and allow approximately 1-kc separation from the high powered active sonars. The corresponding receiving bands are 1.85 to 2.15 kc and 2.25 to 2.55 kc.

The reverse sweep signal will be received by the receiver that is set to accept the normally swept signal and vice-versa. The amount of rejection of the unwanted signal depends on the range resolution and processing filter bandwidth used in the system (Fig. 43). For a system with a 25-ft resolution and 20-cps filters, the rejection is 22 db. Since the propagation losses between 0- and 15-mi ranges are on this order of magnitude, the undesired signal can be as strong as the desired. However, it will be rejected since the approximate arrival times are known from the internal dead reckoning computer and the unwanted signal will be blanked out. When the desired and undesired signals arrive at approximately the same time, the propagation losses are obviously about the same and the unwanted signal will suffer a 22-db rejection loss as compared to the desired. This is sufficient so that no mutual beacon interference occurs.

Several beacons with the same type of coding will be heard on the Navaid receiver, because the stations are as close as 24 mi. When the unwanted station occurs at a different time no problem exists, since it will be blanked out. When it occurs at approximately the same time, it has traveled 20 sec (if a repetition rate of once every 20 sec is used) or about 16 mi further. If the submarine is close to the desired station, the incoming signal is more than 20 db down. However, if the submarine is 15 mi from the desired station, the unwanted signal suffers only a 3-db spreading loss (due to cylindrical spreading at this point) plus an additional two bounces at about 2 db per bounce. This gives only a 7-db advantage to the desired signal which is not considered sufficient. An increase of repetition rate to 30 sec increases this rejection to 10 db, which again is barely sufficient. However, the increase of range difference to 24 mi makes receipt of the two signals occur far enough out (15 mi from one station and 39 mi from the other) so that the best pair of beacons would have codings different than those being discussed.

All that is required to ensure that signals from the opposite swept stations and signals from the same type of station are rejected in the previously discussed manner is to have all stations transmit simultaneously. Since the pulse width is only 50 ms, the 15 stations could

transmit sequentially in time according to position down range and still accomplish the same objectives. Of course, a repetition rate of once every 30 sec is required for this operation.

### 9. Transmitter Characteristics

Enough of the system parameters have been ascertained to allow the transmitter characteristics to be determined. The frequency of operation consists of two bands of 1.9 to 2.1 kc and 2.3 to 2.5 kc. Since it is desirable to have a single projector design, the projector should cover the complete range from 1.9 to 2.5 kc at the 3-db points. Taking a center frequency of 2.2 kc gives a projector Q of 2.2/0.6 or approximately 3.5. Allowing a little more leeway allows a Q of 4 or less to be acceptable for this application.

Figure 39 shows that 500 acoustic watts are required for the 25-ft resolution and a 20-cps filter width FM system is required for a 20-db signal-to-noise ratio. This 20-db signal-to-noise ratio is considered necessary for proper automatic threshold detection. The 500 watts have to be doubled, since the projector will be working 3 db down and at times within its band, there will be some electrical mismatch due to the wide band that the projector has to cover. This means that the projector must be capable of delivering 1000 acoustic watts at its resonant frequency in order to meet the 20-db signal-to-noise ratio for a typical 30-kn submarine. The fact that the projector has a low Q requirement generally means short, thin walled ceramic cylinders (if a ceramic-type design is used). The requirement of 1000 acoustic watts will probably require more than one projector section, which can be used to an advantage since the longer ranges (6.5 to 15 mi) use energy that is radiated in the sector of approximately 10° to 20° from the horizontal. Spacing the elements about 1/2 wavelength will give an increase of about 3 db at 0°, and locating the unit on the bottom will give another approximate 3-db gain. The actual beam pattern for the FM signal has to be calculated from the autocorrelation function in the following manner:

$$R(\theta) = 10 \log = \frac{\sum_{i=1}^n e_i^2 + 2 \sum_{i=1}^{j-1} \sum_{j=i+1}^n e_i e_j \rho_{ij}}{N^2 e^2}$$

where

$R(\theta)$  = the beam pattern relative response to a projector with the N elements closely spaced.

e = the level at the observer of a single projector element.

- $e_i, e_j$  = the level at the observer of the  $i^{\text{th}}$  or  $j^{\text{th}}$  projector element or bottom bounced signal from that element.
- $N$  = the number of projector elements.
- $n$  =  $2N$  ( $N$  direct signals plus  $N$  bottom bounce signals).
- $\rho_{ij}$  = the correlation of the  $i^{\text{th}}$  and  $j^{\text{th}}$  signals as seen by the observer.

The correlation is obtained by determining the relative time delay between two signals (a function of  $\theta$ ) and reading the correlation value from the autocorrelation function shown in Fig. 44. The FM signal in Fig. 44 is for a 250-cps wide FM pulse instead of 200 cps, and, therefore, the autocorrelation function is slightly narrower, but not significantly so.

The resulting beam pattern is shown in Fig. 45 for a two-element projector array where the elements are spaced 1.6 ft apart, and where the lower element is located at various distances from the bottom. Bottom losses as a function of incidence angle have been taken into account in the calculation of the beam pattern. A 0-db level of the beam pattern corresponds to the level received from two elements spaced close together without bottom effects. Increased heights from the bottom have the effect of narrowing the beam since there is a virtual source below the bottom and the effect is to make a longer array. There is no point in increasing the height above the bottom more than 1.6 ft, since the beam pattern becomes too narrow and the level at  $20^\circ$  starts to decrease too much.

At first glance it might seem that some improvement might be gained by steering the beam up to about  $10^\circ$ . This can't be done to any advantage because the effect of the bottom is to give a virtual source with the beam steered down and the net result is no steering, as shown in Fig. 46, where the beam has been phased between the two elements for a  $20^\circ$  steer up. Four or more elements are required in order to steer up properly, and the improvement would be only 1 to 1.5 db at  $10^\circ$ . Since only about two elements are contemplated, the  $0^\circ$  steer position will be used and the bottom will be used to advantage.

One important point here is that spacing, phasing and position above the bottom are not critical due to the wide frequency bandwidth used (Figs. 45 and 46).

The effect of the improvement by spacing and placing the projector close to the bottom is to give an excess signal-to-noise ratio (Fig. 47).

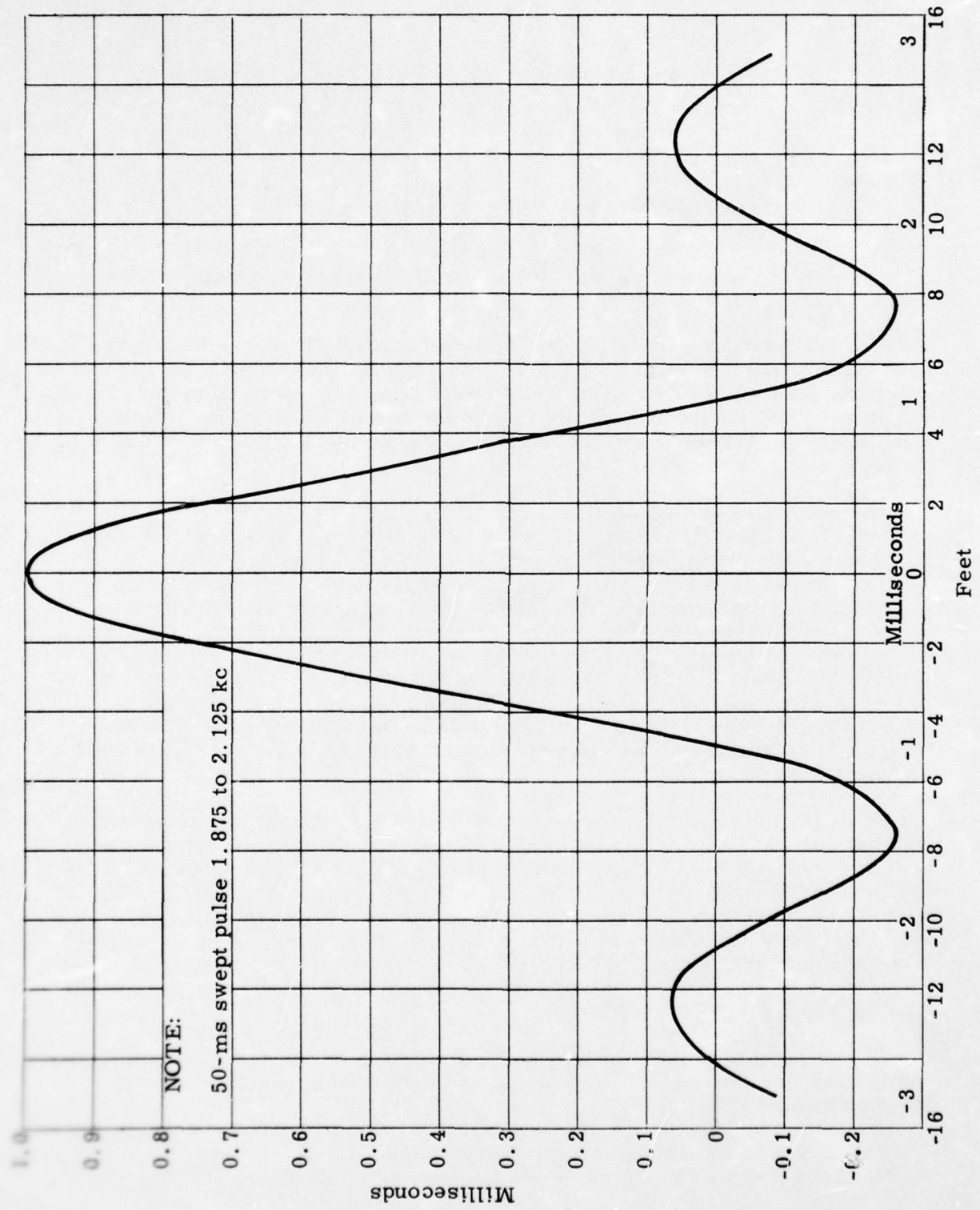

NOTE:

50-ms swept pulse 1.875 to 2.125 kc

Fig. 44. FM Pulse Correlation Function

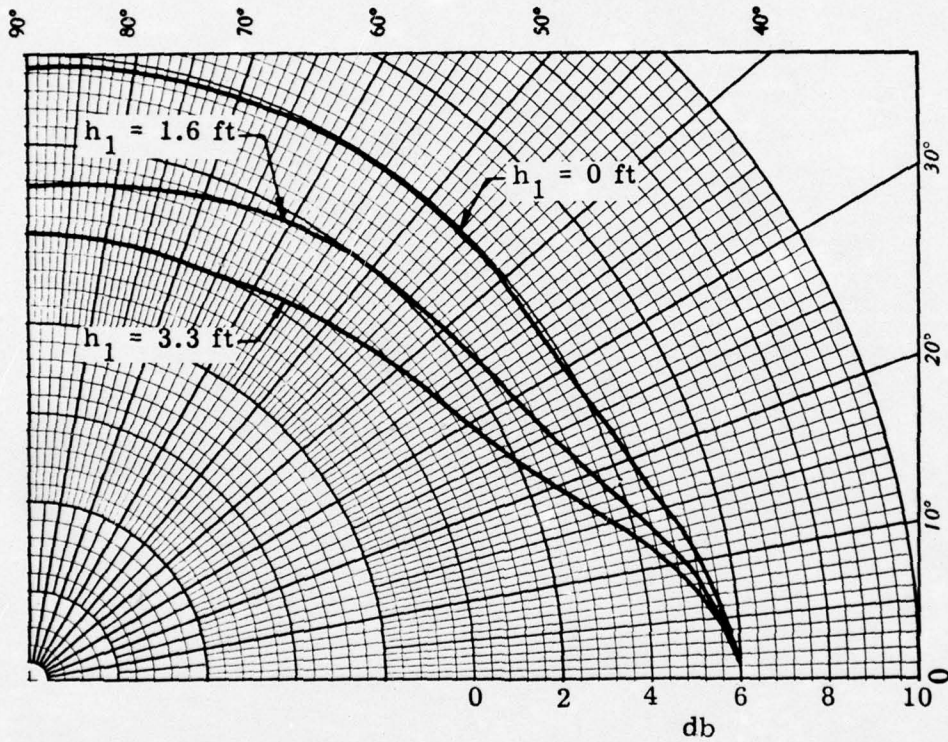

Fig. 45. FM Pulse Transmitting Beam Pattern, Two Element Vertical Array Spaced 1.6 ft ( $h_1$  = distance of lower element to bottom)

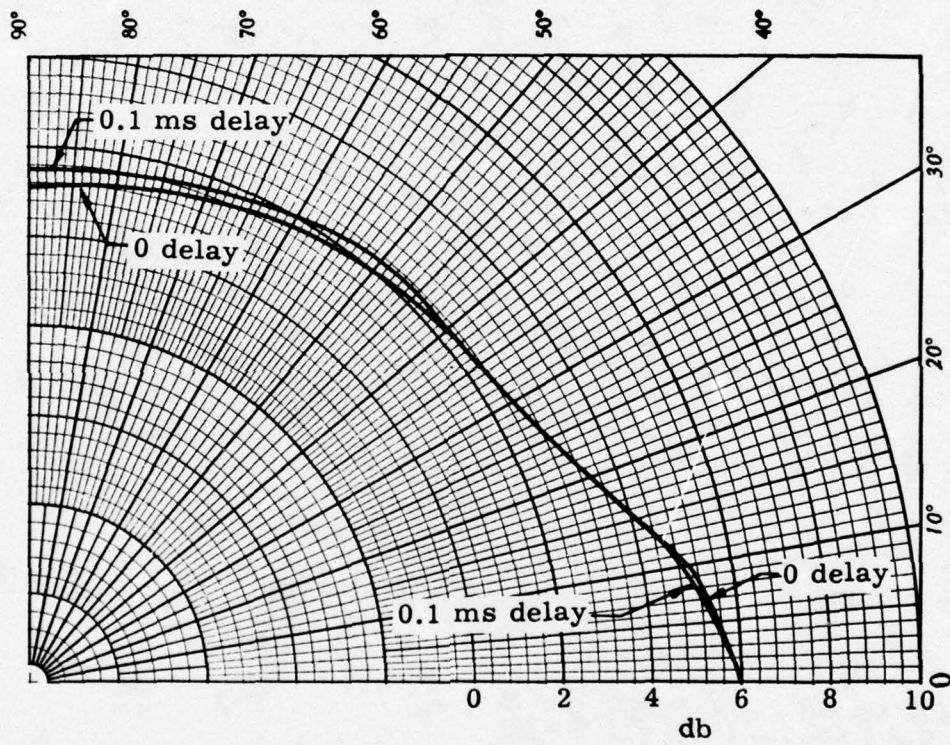

Fig. 46. FM Pulse Transmitting Beam Pattern, Two Element Vertical Array Spaced 1.6 ft ( $h_1 = 1.6$  ft)

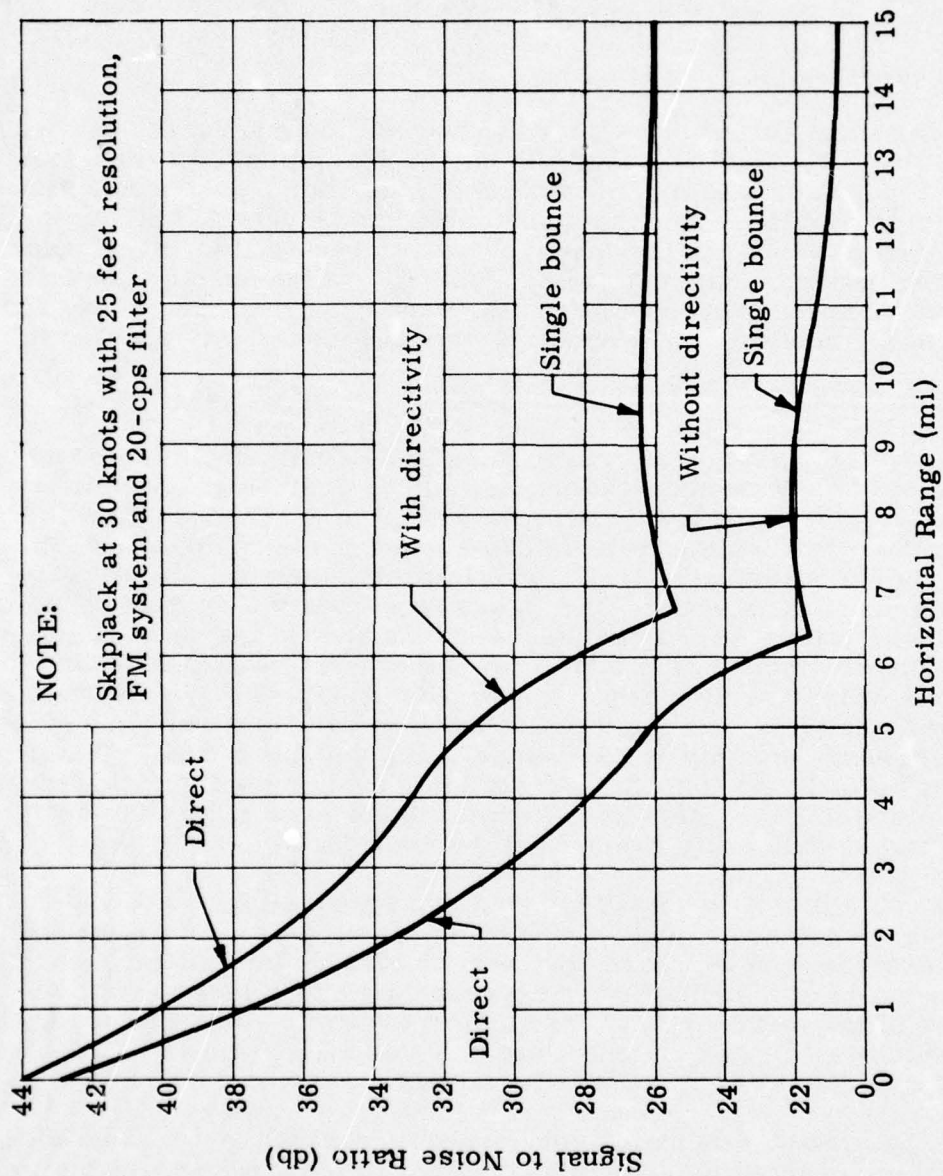

Fig. 47. Signal-to-Noise Ratio Versus Range

CONFIDENTIAL

This excess is required in any case to allow for normal variations in the propagation losses and for possible partial shielding of the bow hydrophone by the submarine at stern aspect.

#### 10. Synchronization

Synchronization of the beacons is required to an accuracy of about 3 ms (15 ft). The only way that this can be accomplished reliably is by cable. If power is supplied by cable from the shore, synchronization presents no problem since the same cable can be used. If power is not supplied from shore, an inexpensive cable is required for synchronization. The only methods that are economical involve sending power of one form or another over cables to the deep beacons. Therefore, accurate synchronization, while required, imposes no serious problems.

#### 11. Cable Link

Two systems have been proven to be satisfactory from a performance point of view as indicated earlier and as discussed in detail in Chapter V. One has a low-loss cable with simple beacons and a shore driver; the other has inexpensive cable and a more complex beacon (including driver and a battery supply) with only control and battery charging circuits on shore. The first system has the highest reliability but is more expensive than the second. The second may have a sufficiently high reliability, but this cannot be ascertained without some on-site tests which are included in the recommendations. Without the results of these tests, the only system that can be recommended with a high degree of certainty is the system using the shore driver, low-loss cable and simple beacon. In the remaining system configuration discussion, and in the system specification (Appendix C), only the design of this higher reliability system will be considered.

The cable link is required for both synchronization and power supply purposes. Since cable costs are the largest single cost item, several things were done to decrease cost with no loss in performance and to reach a reasonable compromise between cost and performance. An example of the last item is the tradeoff between driver size and cable loss, which resulted in the choice of a 20-kw driver and an allowable loss of 8 db for the cable over a 30-mi run.

Two factors lead to an improvement of the first type. First, about one-half the beacons are closer than 30 mi to their respective stations, and second, it is less expensive per circuit (both from an initial and installation cost points of view) to lay a cable with two complete circuits than to lay two cables with a single circuit each (Fig. 48).

CONFIDENTIAL  
ER 12316

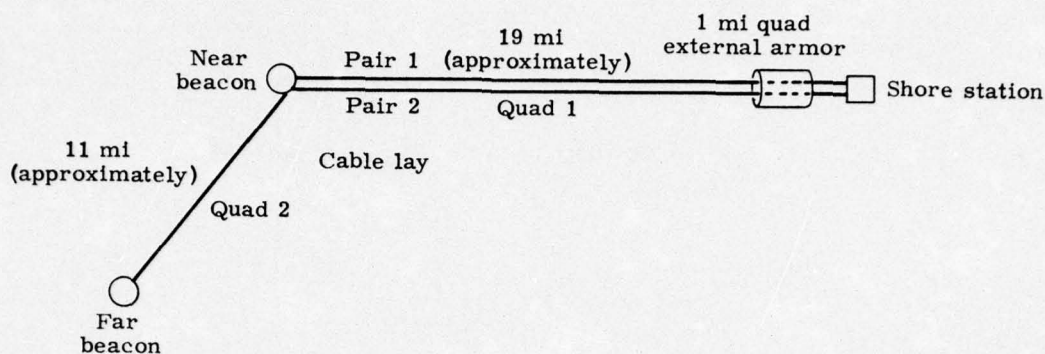

Fig. 48. Beacon Cable Layout

As shown in Fig. 48, a high- and low-loss pair make up a cable called Quad 1. The high-loss pair is used for the closest beacon and has a loss of 8 db for a 19-mi run. (This is a typical value for most of the close beacons.) The low-loss pair is joined at the closest beacon with a second cable type called Quad 2. The Quad 2 cable and the low-loss pair of Quad 1 combine to give a total of 8-db loss for a 30-mi run. (This is a typical value for most of the far beacons.) Thus, both close and far stations have the same loss incurred and the cable size is a minimum in every case. In addition, the fact that two cable pairs are laid together on the 19-mi run to shore saves both cable and installation costs.

A further reduction in cost is made by using internal armor and this particularly lends itself to a Quad cable construction. Internal armor as opposed to external armor is satisfactory in a location such as Exuma Sound due to the prevalent smooth mud bottom and depth of water. Within one mile of shore, however, external armor is required for protection from abrasion and other types of damage. The external armor is fairly expensive and again considerable cost saving is made due to the double pair construction. The interconnecting cable only requires one pair, but one pair is not a stable construction for internal armor. Therefore, two smaller pairs in parallel are used to form the Quad 2 cable.

Since Beacon 3 has no related pair beacon, it is powered over 16 mi of Quad 2 cable by itself. All other beacons are in pairs and are powered as shown in Fig. 48. Of course, the last mile for Station 1 (1.5 mi for Station 2) near the shore station is externally armored.

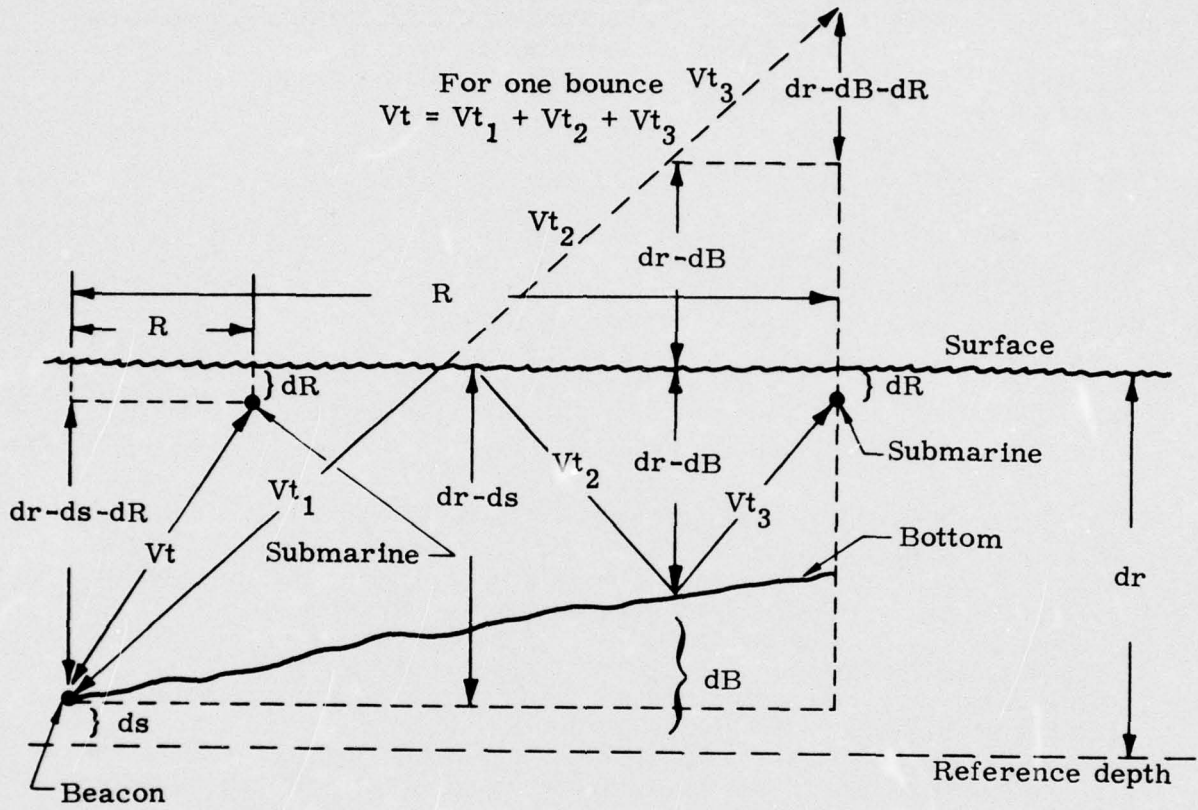

Fig. 49. Range Computation Geometry

Normally, cables are installed with 5% slack (excess of cable length as compared to distance covered) and an additional 10% to allow for a safety margin in case of navigational errors and extra slack for future retrieval. This additional 15% is included in the cable runs shown in Appendix C.

## 12. Navigation Equation

The navigation computer can easily derive travel time from the two beacons being used for navigation by timing the difference between the clock output and corresponding received acoustic pulse from each beacon. Once these two times are derived, the computer has to convert them to horizontal ranges before it can compute the actual submarine position. This conversion of time to horizontal range is not easily accomplished as can be appreciated by looking at the ray paths of Figs. 26, 27 and 28 and considering the effects of submarine depth, source depth, deviation from a flat bottom, and depth-velocity profile changes. A study of the ray paths has provided a means of accomplishing this. Straight line ray paths are assumed initially and this gives two right triangle solutions, one for the direct path and one for the single bounce path (Fig. 49). In the single bounce case, the triangle is formed by successive mirror images of the actual sound path. In the case of the direct path, the triangle has sides  $R$  and  $(dr-ds-dR)$  and a hypotenuse,  $vt$  ( $v$  = average velocity of sound and  $t$  = travel time). Solving for horizontal range gives

$$R = \sqrt{(vt)^2 - (dr-ds-dR)^2}.$$

In the case of the single bounce path, the sides are  $R$  and  $(dr-ds-dR + dr-dB+dr-dB-dR)$  and the hypotenuse is again  $vt$ . In this case, solving for  $R$  gives

$$R = \sqrt{(vt)^2 - (3dr - 2dB - ds - dR)^2},$$

which is really similar to the equation for the direct case, but is more general. It will be the only one considered since it gives the direct case by making  $dB = 0$  and  $dr = 1/3 dr$ . This equation takes into account travel time, submarine depth, source depth and bottom bounce depth, but doesn't account for changes in the average velocity of sound and departure of the actual ray path from straight lines. These effects can be approximated to any desired degree of accuracy by incorporating range, source depth, submarine depth, bottom bounce depth and depth-velocity profile changes into the average velocity ( $v$ ) term. The accuracy of the corrections can be improved by increasing the order of the equations involving each term. A study of the ray path diagrams indicates that second order equations are sufficient, but this should be compromised and modified by onsite accuracy tests as described in paragraph 4.3.7 of

Appendix C. Incorporating these second order corrections gives the following equation:

$$R = \sqrt{\left[ t(K_1 + K_2 t + K_3 t^2 + K_4 d_s + K_5 d_s^2 + K_6 d_B + K_7 d_B^2 + K_8 d_R + K_9 d_R^2) \right]^2 - \left[ -d_R - 2d_B - d_s + 3d_r \right]^2}$$

where

$K_1$ ,  $K_2$  and  $K_3$  are front panel adjustments (to compensate for changes in the depth-velocity profile) and provide compensation for ray bending with range.

$K_4$  and  $K_5$  provide correction for average velocity changes due to different beacon depths.

$K_6$  and  $K_7$  provide corrections for bottom bounce depth variations.

$K_8$  and  $K_9$  provide for average velocity changes with submarine depth and correction for increased ray curvature with depth.

All the constants (and any additional ones) can be determined by the previously referenced accuracy test described in Appendix C.

$t$  = travel time and is easily determined from the timing and acoustic inputs.

$d_r$  = a reference depth (5000 ft, for instance)

$d_s$  = a beacon constant ( $d_r - d_s$  is the beacon depth)

$d_R$  = the submarine depth

$d_B$  = the difference between the bottom bounce depth and the reference depth.

The last item is a function of not only the particular beacon but the range and bearing from that beacon. It is the only item that is not explicitly known. It can easily be derived, since the computer has to determine range and bearing to the close beacons in order to decide which two beacons to utilize. The bottom bounce depth can be derived by a cam on the bearing servo which contains the average bottom slope

as a function of bearing over the range of 4 to 11 mi (since the only bottom bounce signals of any interest hit the bottom at these ranges). This slope can be multiplied times the estimated range and used as the bottom bounce depth. A discussion and development of the above equation is contained in Appendix E.

Another function of the computer is to select the two beacons to be used for position determination. The computer does this by determining the closest A, B, C and D beacons from its estimated position and known beacon positions. Once this is done, the computer can easily compute range, bearing and range rate from its estimated position, submarine velocity input, submarine heading input and known beacon coordinates. The two closest beacons (each of a different coding) are to be selected in all cases, except when their relative bearings are within  $\pm 15^\circ$  of either  $180^\circ$  or  $0^\circ$ . The reason for this is that the base line errors can become excessive in these cases and the best two beacons are then the closest and third closest beacons. The range rate signals can be used to correct for doppler and the estimated range signals can be used to range gate the incoming acoustic signals.

One other item that the computer has to take care of is the fact that usually one beacon signal will be received and its corresponding range determined at a different time from the second beacon. The actual position computation cannot be made until both ranges are available, and if the submarine is traveling at 50 fps (30 kn), it can possibly increase the first range as much as 800 ft by the time the second signal is received (for an 18-sec difference in travel time). This can be easily compensated for by applying range rate correction, which has already been derived for doppler correction, to the first range received and thus update it until the second signal is received.

## B. BLOCK DIAGRAMS

The block diagrams of shore equipment, beacons, shipboard equipment, the navigation computer and a computer analyzer are discussed in the following paragraphs.

### 1. Shore Equipment

The block diagram of the northern shore station is shown in Fig. 50, and the basic parts of the shore equipment are discussed in detail in the following paragraphs.

#### a. Timing

The basic timing reference for the whole system is a digital clock located at Station 1, which has an overall accuracy of  $\pm 3$  ms for an

CONFIDENTIAL

unattended 24-hr period. This amounts to a  $\pm 15$ -ft navigation error and, therefore, has negligible effect on the system accuracy. The clock timing is continuously checked against WWV transmissions in the WWV comparator. Periodically (at least once every 24 hr), the digital clock is manually brought into synchronism with WWV. The clock is also provided with a visual display of time, for synchronization and informational purposes. Station 2 receives its timing from radio transmissions derived from Station 1.

b. Control

The control circuitry takes the clock or radio signals (for Stations 1 and 2, respectively) and generates the four station coding sequences required. In addition, it provides gating signals such that the output of the driver is automatically switched to the appropriate beacon cable pair just prior to pulse transmission. Manual switches are provided on this unit so that any one of up to twelve beacons can receive any one of four codes, or be inactivated in any sequence desired. Capability of handling up to twelve beacons is provided, since this covers the requirements of future range expansion, allows more versatile testing and requires only the addition of a few more switches.

The control circuitry is really the heart of the system since it is the unit that determines all but the power level of the transmitted signals. Changes of pulse characteristics can be made at any time (although a corresponding change is required in the navigation computer) within the frequency limitations of the projector system.

c. Power driver

The signals generated by the control circuitry are amplified up to a power level of up to 20 kw by the power driver. The power output of this driver is controllable from 1 to 20 kw. Protection is provided by internal circuitry for open circuit load conditions and by buses and breakers for short circuit load conditions.

d. Synchronization

The radio transmitter is used initially to transmit timing reference signals to the test ship during the location tests and initial accuracy tests, thus eliminating the need for digital clock synchronization with WWV. As the program proceeds the digital clocks will be, of necessity, locked in the WWV. The radio transmitter will serve two purposes after the range is operational. One is to supply timing reference signals to surface ships desiring to use the underwater navigation aid and the other is to provide the source of timing signal for the South Exuma Sound station (Station 2) at Stevenson, Great Exuma Island, and thus eliminate the need for an additional digital clock.

CONFIDENTIAL  
ER 12316

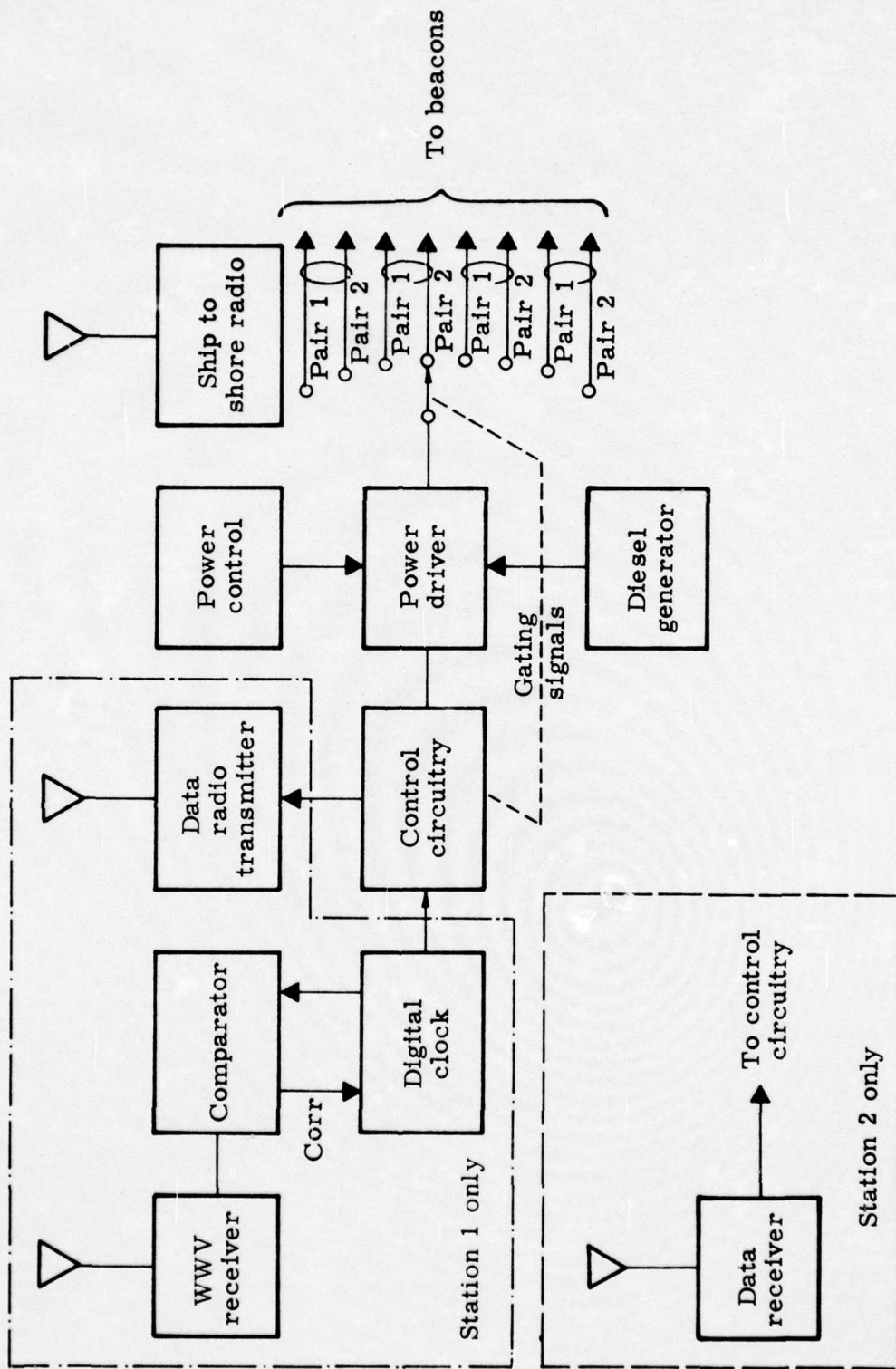

Fig. 50. Station Equipment, Block Diagram

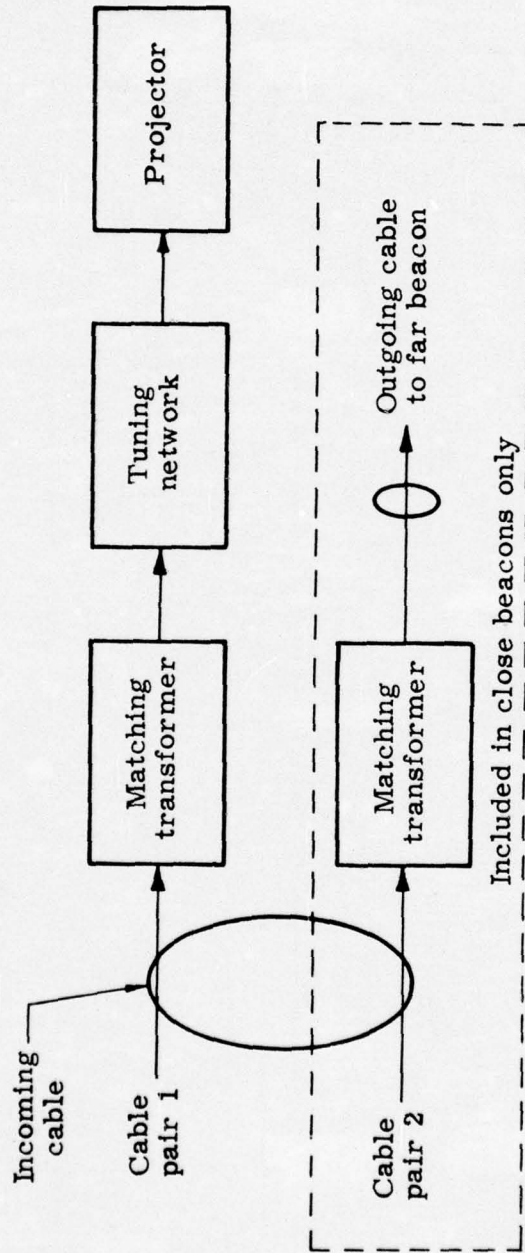

Fig. 51. Beacon Block Diagram

### e. Communications

A ship-to-shore radio will be included at the shore station for communication with surface ships and submarines during installation, location, accuracy and operational tests. It will also be used for emergencies and as the main source of communication to Georgetown, Nassau and Miami.

### 2. Beacon Block Diagram

The block diagram for the deep beacons is shown in Fig. 51. The matching transformer matches the characteristic impedance of the cable to the projector in the frequency range of interest. A double tuned network is used so that the projector will be matched at both the frequency bands of interest (1.8 to 2.0 kc and 2.2 to 2.4 kc). A matching transformer is also included in the close beacons to match the two different characteristic impedances between the low-loss Quad 1 pair and the two parallel pairs of the Quad 2 cable that go to the far beacons.

### 3. Shipboard Equipment

The shipboard equipment that will be required to perform the location and accuracy tests of Appendix C is shown in Fig. 52. The hydrophone-preamplifier assembly will be lowered on a cable to duplicate the conditions of a submarine at various depths between 150 and 1500 ft.

#### a. Hydrophone-preamplifier assembly

The hydrophone-preamplifier assembly should consist of a pressure equalized hydrophone and a low noise transistorized preamplifier designed to operate at 3000-psi ambient pressure, or more. The hydrophone-preamplifier combination should have a sensitivity of -70 db/volt/bar, or better, flat within  $\pm 2$  db from 0- to 3000-psi ambient pressure, an output impedance of 100 ohms or less, and a response flat ( $\pm 1$  db) from 1.5 to 3 kc.

#### b. Hydrophone test rig

The hydrophone-preamplifier should be mounted in a small protective housing with acoustic isolation to prevent cable and water noise from being coupled directly to the hydrophone. This rig should be attached to at least a 250-lb concrete anchor to provide the necessary sinking force.

AD-A031 531

MARTIN CO BALTIMORE MD ELECTRONIC SYSTEMS AND PRODU--ETC F/G 17/7  
SUBMERGED SUBMARINE NAVIGATION AID STUDY.(U)  
MAR 62

NOBSR-85577

UNCLASSIFIED

ER-12316

NL

2 of 3

AD  
A031531



CONFIDENTIAL

## c. Test cable

An electrical-mechanical cable 1600 ft long will be required to lower the test hydrophone to any depth between 0 and 1500 ft. This cable should have two dry double-shielded twisted pairs to provide the necessary connections to the hydrophone preamplifier. The cable should have two layers of opposite wound steel external armor for protection, antitorquing and to minimize acoustic noise.

## d. Experimental computer

The experimental computer will compute position continuously, and periodically correct the computed position with sonar position. The computer will contain all the functions for the navigation computer, except that it will have manual switching of beacon constants, no doppler correction, manual depth corrections and a visual rectangular coordinate output instead of the more elaborate functions of the operational-type computers. The reason for the above is that the intent of this part of the program is to determine the computer configurations and constants and system accuracies, and not to prove out portions of the system that can readily be designed. The latter is the function of a prototype operational-type computer.

A surface ship will be used for the tests and the ship will essentially stay on station since the hydrophone position and depth will not be known accurately if the ship's speed is above a few knots. This means that no doppler corrections are required and there is plenty of time to insert the numerous beacon constants and corrections manually. This also provides the most flexibility which is highly desirable in this portion of the tests.

Initially, the timing reference will be derived directly from the radio timing signals since this doesn't require any effort to keep two digital clocks locked in the WWV. This is especially desirable in the initial portion of the tests where the equipment will probably be turned on and off frequently and the station site will be manned only during test intervals. The digital clocks require about 4 to 8 hr continuous operation to stabilize out to the point where only 24-hr corrections are required. As the problems and navigation computer constants are worked out, the digital clocks will be locked in with WWV, and overall system accuracy and performance using the synchronized clocks will be demonstrated and determined.

After the range is operational, the digital clocks can be left operating all the time so that the warmup time is eliminated. Even in the case of cold startup, the operator will have no other primary function than to monitor system operation and it will be no problem to synchronize

CONFIDENTIAL  
ER 12316

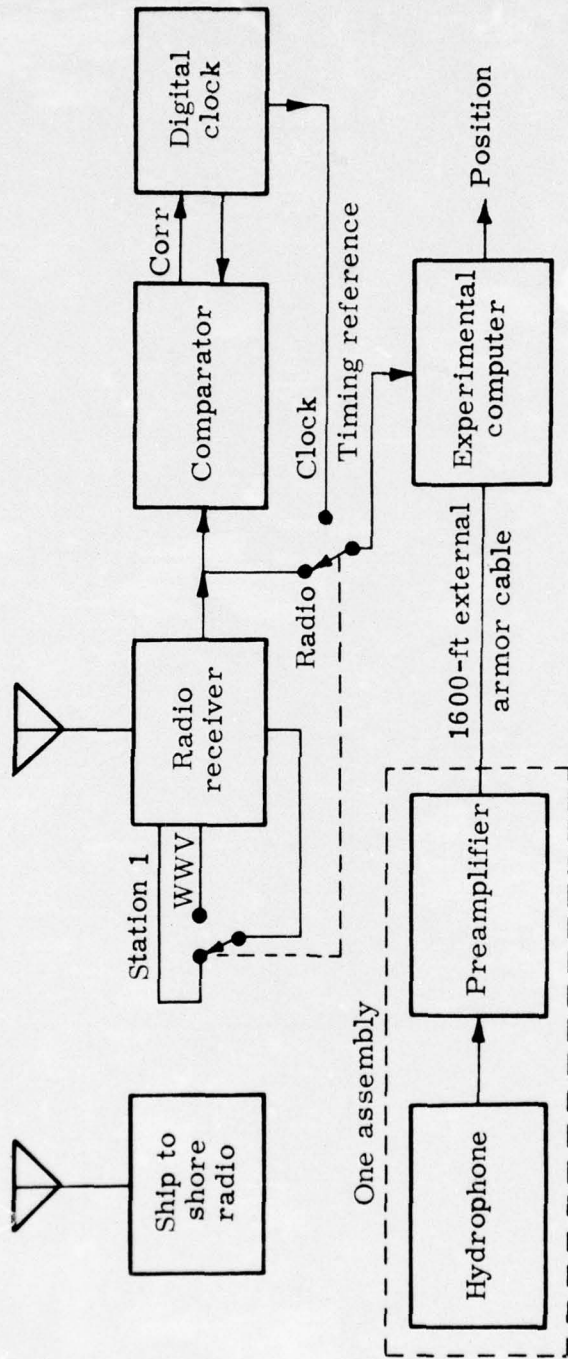

Fig. 52. Shipboard Equipment Block Diagram

CONFIDENTIAL

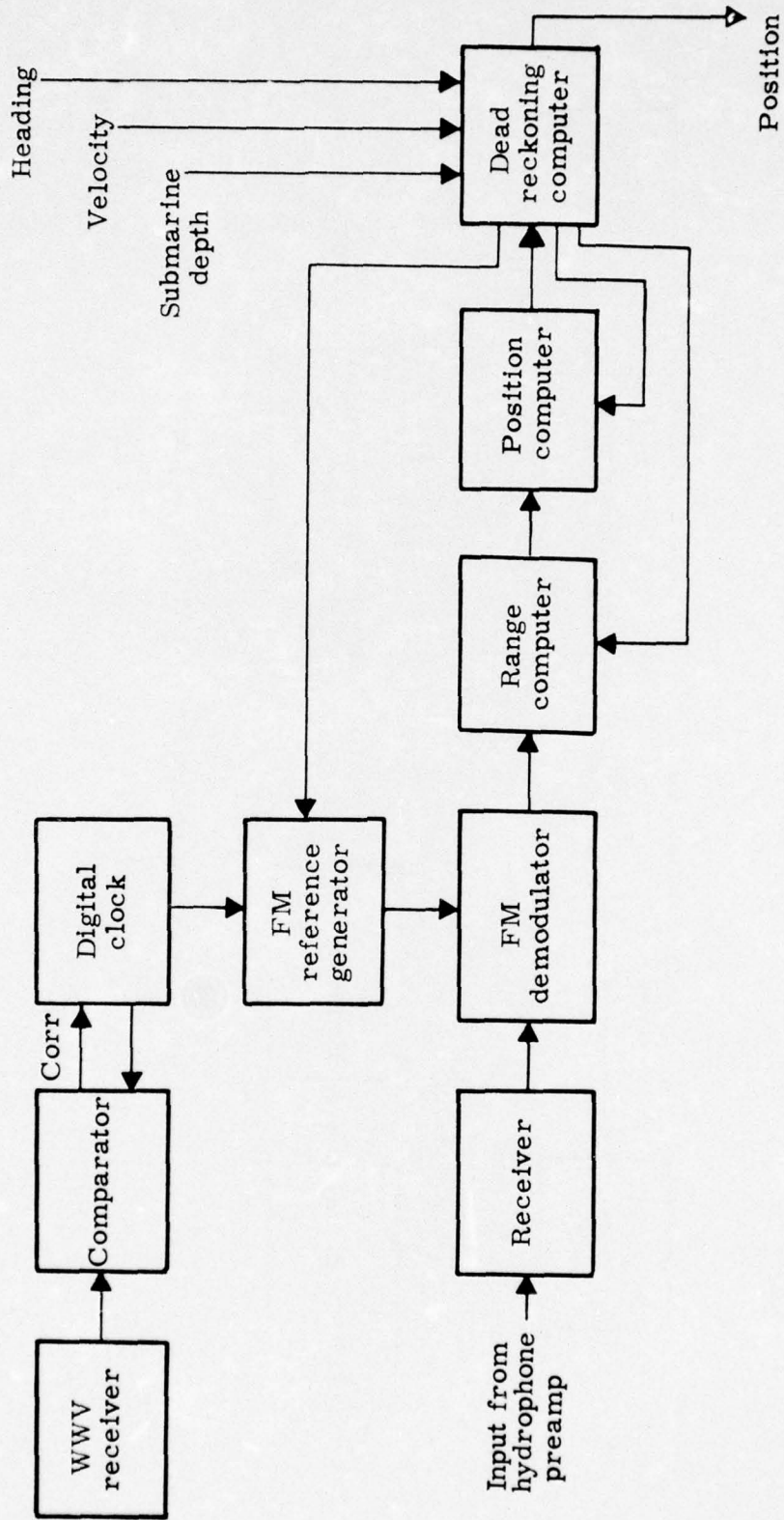

Fig. 53. Navigation Computer Block Diagram

CONFIDENTIAL

the clock periodically. Of course, the digital clock used with the experimental computer will be used with the prototype computer to give a complete system, capable of operation with one submarine.

#### 4. Navigation Computer (Fig. 53)

The purpose of the navigation computer is to continuously compute the submarine position. The computer should be constructed of solid-state components only, to minimize size and weight. The individual blocks are discussed in the following paragraphs.

##### a. Time reference

The time reference is derived from a digital clock of the identical design described earlier, except that a BCD digital output will be provided for recording. The complete clock will be a purchased item.

##### b. Receiver

The function of the receiver is to limit the wide band hydrophone input to the desired frequency bands, to provide sufficient amplification of the signals up to a convenient level and to provide AGC action to compensate for varying noise levels. A total of 70 db of AGC dynamic range will be provided to allow compensation for noise levels from 0 speed at sea state 0 to 30 kn or more at sea state 6. The receiver will have a maximum voltage gain (with 0 AGC voltage) of 100,000.

##### c. FM Reference Oscillator

The FM Reference Oscillator provides a synchronous reference signal for the four different station codes on the basis of the timing signals received from the digital clock. This portion of the system is roughly equivalent to the control circuitry of the shore station and is easily modified to new or different station codings; doppler correction is provided by data supplied from the DRC.

##### d. FM Demodulator

The FM Demodulator performs the function of analog correlative demodulation of the input signals and the FM reference signals. This is accomplished for the two signals from the two best beacons as determined by the dead-reckoning computer (DRC). The FM Demodulator also determines the fine range increment of the received signals by passing the demodulated signal through a bank of 10 comb filters.

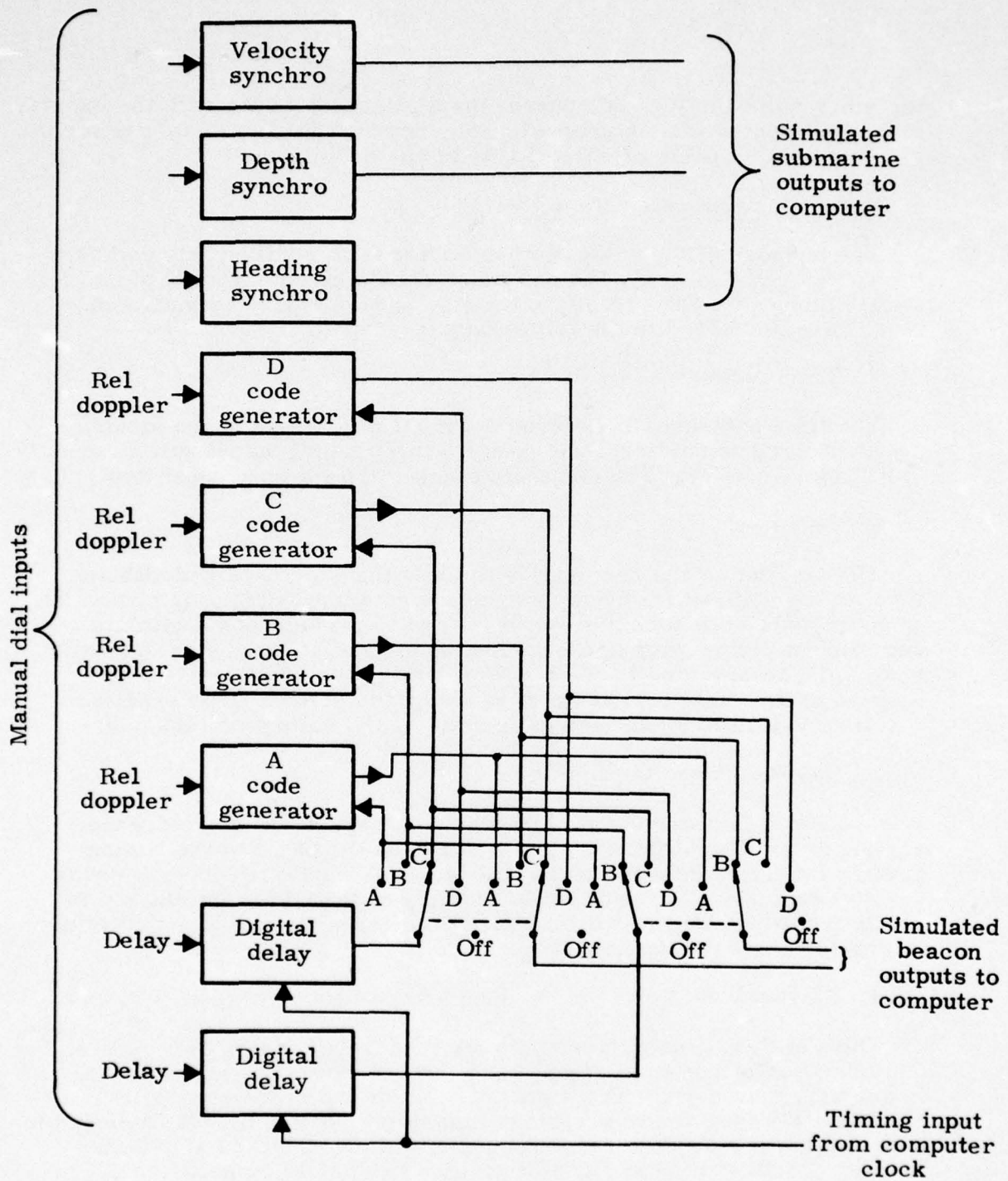

Fig. 54. Computer Analyzer Block Diagram

e. Range computer

The range computer determines the fine and coarse horizontal range, by digital means, to each of the two stations from data and timing inputs from the FM Demodulator and digital clock, and path corrections from the DRC. It also provides updating (from DRC data) of the first range signal received until the second range signal is received.

f. Position computer

The position computer computes the submarine position by digital means from the two range inputs of the range computer and the beacon coordinates supplied by the DRC. Two solutions are computed and the ambiguity is removed by present position information from the DRC.

g. Dead-Reckoning Computer

The Dead-Reckoning Computer continuously computes present position from the last known position in a hybrid analog-digital manner from submarine velocity, heading and depth inputs. It accepts corrected position data from the position computer if the acoustic position agrees with the computed position within 1/3 of a mile or less. If three successive acoustic positions disagree with the corresponding computed positions, a warning light is activated.

The DRC also supplies doppler correction and code selection to the FM reference oscillator; range gating, depth correction and bottom corrections to the range computer; and beacon coordinates and present position to the position computer.

The output of the DRC is in rectangular and latitude-longitude coordinates on visual indicators. Either of these two outputs are selectable for recording in digital form and for X-Y plotter display in analog form.

5. Computer Analyzer

The purpose of the computer analyzer is to provide a means of calibration and testing of the navigation computer without requiring on-site tests. The block diagram of this unit is shown in Fig. 54.

Submarine velocity, depth and heading outputs are simulated by manual vernier dials which control synchro transmitters. The simulated beacon signals are derived by generating two selectable codes with accurate adjustable time delays from the navigation computer digital clock output. In addition, these codes have manual relative doppler variation adjustments.

CONFIDENTIAL

The normal calibration procedure (once the analyzer is attached to the computer) is to put given values into the analyzer and given values of present position into the navigation computer's DRC. It is then determined if the desired functions occur in the prescribed manner and if the corrected positions are computed to within the specified limits of the known position solutions.

CONFIDENTIAL  
ER 12316

## V. OPERATIONS ANALYSIS

Initially, the operations analysis was used as a guide to determine the qualitative and quantitative objectives of the experimental program and therefore help set up the experiment. After that, the purpose of this part of the study was to obtain the optimum compromise between the operational requirements, area coverage, accuracy, power supply method, cost of the system and growth capabilities. The objectives of the experimental program were discussed previously; the remaining items are discussed in detail below.

### A. OPERATIONAL REQUIREMENTS

A study of the operational requirements of a submerged Submarine Navigation Aid System in Exuma Sound concluded that the installation should:

- (1) Provide an area where the submerged submarine is able to determine its position with a high degree of accuracy for weapon and equipment development evaluation. Accuracy is the principal requirement of this function. The size of the insonified area depends primarily on the range of the weapon or equipment being evaluated and usually does not require an extremely large area.
- (2) Provide an area where fleet ASW operations can be effectively evaluated. The size of the area is the principal requirement for this function. It should be of sufficient size to permit large complex ASW formations and exercises. The accuracy required will be dependent upon the deviation of errors of the ASW search, localization and kill system.

#### 1. Evaluation of Operational Exercises

There is a need for an area where the ASW fleet forces can conduct exercises with one or more submerged targets and have accurate positioning information of all forces participating in the postexercise evaluation. Installation of the conventional above-water navigational methods on the surrounding isles at Exuma Sound would provide the sufficient accuracy for the air and surface forces and installation of a 50-yd accuracy underwater system would provide a method of accurately determining the submarine's position.

The size and scope of the exercises conducted in Exuma Sound would be determined by the area insonified by beacons. The area be-

CONFIDENTIAL

tween the 100-fathom curves is about 3300 sq mi and coverage of a large portion of this area would permit fleet ASW units to exercise all phases of ASW operations. Shore-based or carrier-based aircraft could conduct fixed area searches, and track charts of the exercise would confirm or deny their reported detections. In the localization phase of the exercise, the degree of error of their sonar patterns could be accurately determined. Knowing the position of the submarine and the attacking forces at the time of a simulated weapon drop, a realistic kill assessment could be made. In all phases of the exercise, a true evaluation can be made of procedures, equipment and operator performance.

## 2. Search

The positioning error of the submarine with a 50-yd navigation accuracy will be insignificant when compared to the system errors of Jezebel, aircraft radar, or long range active and passive sonars of surface ships or submarines.

## 3. Localization

In all cases, except that of active sonar search at short ranges (1000 yd) by surface ships or submarines, the navigation errors of a 50-yd system will be insignificant compared to the localization errors. For the short range active sonars, the contribution of the submarine positioned error will be approximately equal to the localization errors. The localization errors and attack errors for airborne equipment are shown in Table 1. This includes all pertinent errors, including aircraft navigational errors, etc. Surface sonar errors are also given in Table 1.

Elimination of significant submarine position error permits a better evaluation to be made of equipment parameters, tactics, training, etc. The significant errors are those associated with equipment, operators and vehicles of the ASW forces. It also permits a better evaluation of parameters such as false contact rate, minimum and maximum detection ranges, reliability, etc.

TABLE 1  
Localization Errors

<u>System</u>	<u>Error</u> <u>(yd)</u>	<u>Range</u> <u>(yd)</u>
Localization Equipment (airborne)		
Range only sonobuoy	200 to 400	2200
Directional listening sonobuoy	200 to 400	
Julie sonobuoy	100 to 200	4000

CONFIDENTIAL  
ER 12316

TABLE 1 (continued)

<u>System</u>	<u>Error (yd)</u>	<u>Range (yd)</u>
MAD	100 to 250	345 to 980
Surface Sonar	10 to 25	250
Surface Sonar	15 to 30	500
Surface Sonar	20 to 40	1000
Surface Sonar	50 to 70	2000
Surface Sonar	125 to 150	5000
Surface Sonar	200 to 250	8000
Attack (airborne)		
Ro-Ro sonobuoy contact with weapon	200 to 400	
DLDL sonobuoy contact	200 to 200	
MAD-weapon	100 to 250	

4. Weapon Evaluation

The inability to accurately position the submarine in relation to the weapon delivery vehicle has previously precluded a reliable evaluation of the weapon performance in the case of a dummy weapon drop or the reliable assessment of a kill in the case of a simulated weapon drop. Conducting kill exercises in the Exuma Sound area utilizing the navigation system described will permit an undistorted evaluation of the weapon effectiveness since the accuracy of the navigation system is very high (50 yd). The resulting errors, due to the navigation system, are negligible when compared to the range of the weapons.

Table 2 shows the effective ranges of current ASW weapons. In all cases, the navigational positioning errors of a 50-yd submerged navigation aid permit an accurate evaluation of the weapon's performance, or assessment of a kill (in the case of a simulated drop). If postexercise evaluation finds that the delivery unit actually dropped the attack exercise weapon within the weapon's effective range but failed to register a hit, the cause for the miss can be limited to weapon performance. If a simulated drop is made and, from the comparison of the tracks of the submarine and attacking units, it is determined that the drop was made when the submarine was within effective range, a kill can be realistically assessed.

CONFIDENTIAL

TABLE 2

Table of Effective Ranges of ASW Weapons

<u>Airborne Weapon</u>	<u>Detection or Kill Range (yd)</u>	<u>Submarine Depth (ft)</u>
MK43	800	--
MK44	1000	--
MK46	1000	--
MK90	1400	400
	1525	1000
MK101	980	50
	1160	100
	1360	250
	1660	500
Hedgehog	285	300

#### 5. Navigational Safety

In all submarine operations, the safety of the submarine is paramount. Operating in an area covered by submerged navigational beacons will provide a safety factor in navigation and collision prevention that the submarine has not previously enjoyed. As long as the submarine is within the acoustic range of two beacons, he will be able to determine his position with an average error of approximately 50 yd. This positioning accuracy is particularly desirable in an area like Exuma Sound where the water shoals rapidly near the surrounding islands.

The conclusion at this point is that a 50-yd accurate navigation underwater navigation system covering a large portion of the area between the 100-fathom curves in Exuma Sound will provide a sufficient accuracy and operating area to permit accurate weapons, systems evaluations and exercises in all cases. In cases where the ships and submarine's sonar ranges are less than 1000 yd, the navigation system will contribute more error than the sonar's; but sufficient accuracy to evaluate the outcome of the exercise still exists.

CONFIDENTIAL  
ER 12316

## B. AREA COVERAGE

Considerable emphasis was placed on obtaining comparisons of the area sonified and the accuracy to be expected. The beacons were initially positioned by considering the area to be a 40- x 100-naut mi rectangle. The separation of the beacons was obtained by solving the following set of equations:

$$N = (m + 1) \left( \frac{100}{x} + 1 \right),$$

$$2a + mb = 40,$$

$$2(R-b) + 2R^2 - x^2 = b$$

$$\text{and } a = R^2 - x^2$$

where:

$N$  = the total number of beacons and  $\frac{100}{x}$  is rounded off to the next largest integer

$R$  = the maximum range of a beacon

$m + 1$  = the number of rows

$b$  = the separation distance between beacons in a column

$a$  = the distance between the nearest row and the side of the rectangle

$x$  = distance between rows.

Solution of the above equations for beacon ranges of 5, 10 and 15 naut mi are tabulated in Table 3. The results are based on solving the equations for values of  $m$ ,  $b$  and  $x$  that give the minimum  $N$ .

TABLE 3

Number of Beacons Required for a 100- x 40-naut mi Rectangle

Beacon Range (naut mi)	No. of Beacons Required	No. of Rows	Distance Between Columns	Edge Distance	Distance Between Rows
15	18	2	12.5	8.5	23.3
10	39	3	8.65	5	15
5	140	5	3.73	3.33	8.33

CONFIDENTIAL

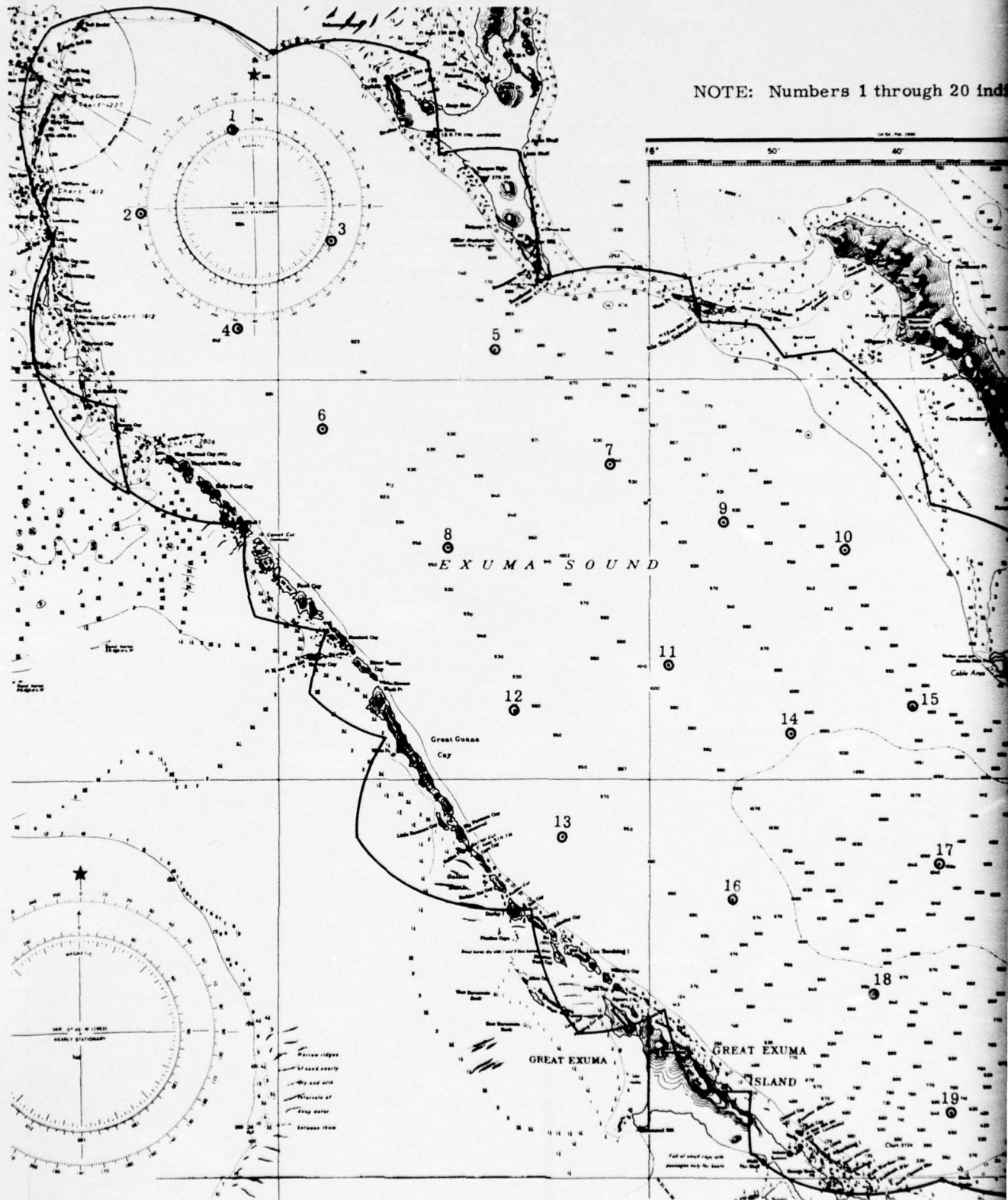

NOTE: Numbers 1 through 20 indicate

Fig. 55. Coverage Provided

CONFIDENTIAL

ER 12316

CONFIDENTIAL

NOTE: Numbers 1 through 20 indicate beacon positions.

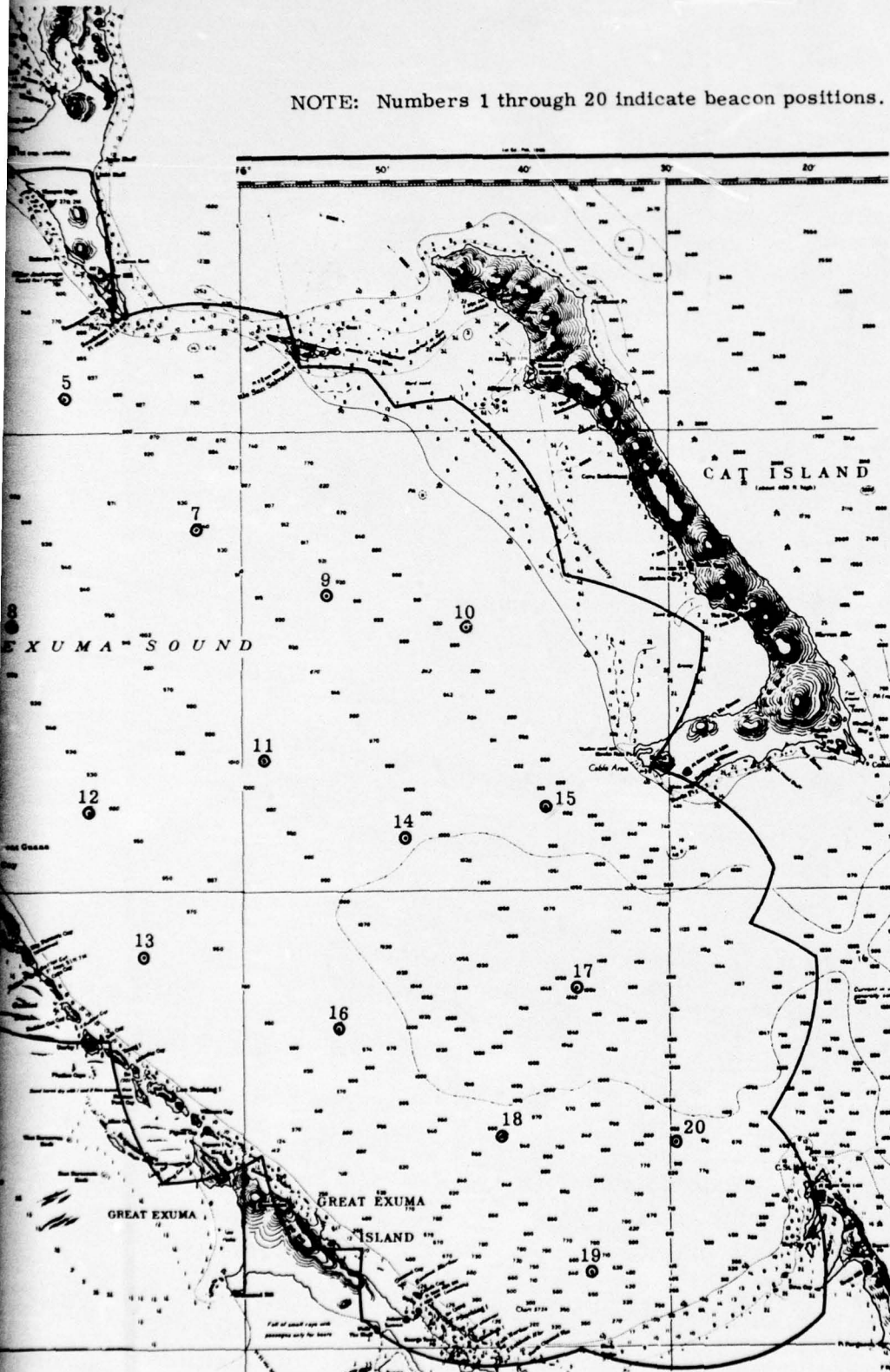

Fig. 55. Coverage Provided by 20 Beacons (complete coverage 3326 sq mi)

CONFIDENTIAL

FR 12316

2

It is indicated from the above table that the requirement to use direct ray paths with a range of 5 naut mi would require 140 projectors. Experiments in Exuma Sound demonstrated the feasibility of using the bottom bounce technique and obtaining a range of approximately 15 naut mi. Using this projector range, the number of beacons is greatly reduced.

The next step was to lay out positions of beacons on a map of Exuma Sound such that all portions of the Sound beyond the 100-fathom curve were within 15 naut mi of at least two beacons. A minimum of two beacons is required to provide a submerged submarine navigational range. A number of configurations were tried, ranging from a single pair of projectors up through 20 beacons. The 20-beacon installation would insonify approximately all the area within 100-fathom curves (Fig. 55). The difference between this figure and the 18 beacons indicated in Table 3 is due to the irregular contour of the Sound, and the requirement to ensure that the base line (the line extended between two projectors) is covered by a third beacon from the adjacent pair.

Several different concepts of beacon groupings were investigated. These ranged from a string concept where the projectors were equispaced from one another, to a pair concept with pairs of beacons equispaced and a triangular concept where groups of 3 beacons were used. A comparison of the accuracy versus area curves for each of these concepts is given in Fig. 56. As can be expected, the plotted curves indicate that as the number of beacons is increased the accuracy and the area sonified increases. However, the cost of the range also increases and is roughly proportional to the number of beacons installed.

The string of eight beacons installed down the center of Exuma Sound, with an optimum distance of 13.4 mi between beacons, covers a comparatively large area (over 2000 sq mi, see Fig. 57). However, an extremely poor accuracy (positioning error over 100 yd) is present in the vicinity of the base line between projectors. This would result in a poor accuracy area strip through the center of the operating area.

Positioning three beacons in the form of an equilateral triangle with 10-mi sides gives an area coverage of 625 sq mi. The poor accuracy in the vicinity of the base lines is eliminated, since each base line is covered by the third beacon. Using this configuration, and installing the projectors in one group of three and three groups of four, the 15 projectors would cover 2809 sq mi (approximately 84% of the total possible area) and provide the maximum accuracy coverage as shown in Fig. 41. This large an area would permit unlimited fleet ASW exercises and, at the same time, provide areas of high accuracy (25 yd or less) where new development operations could be conducted.

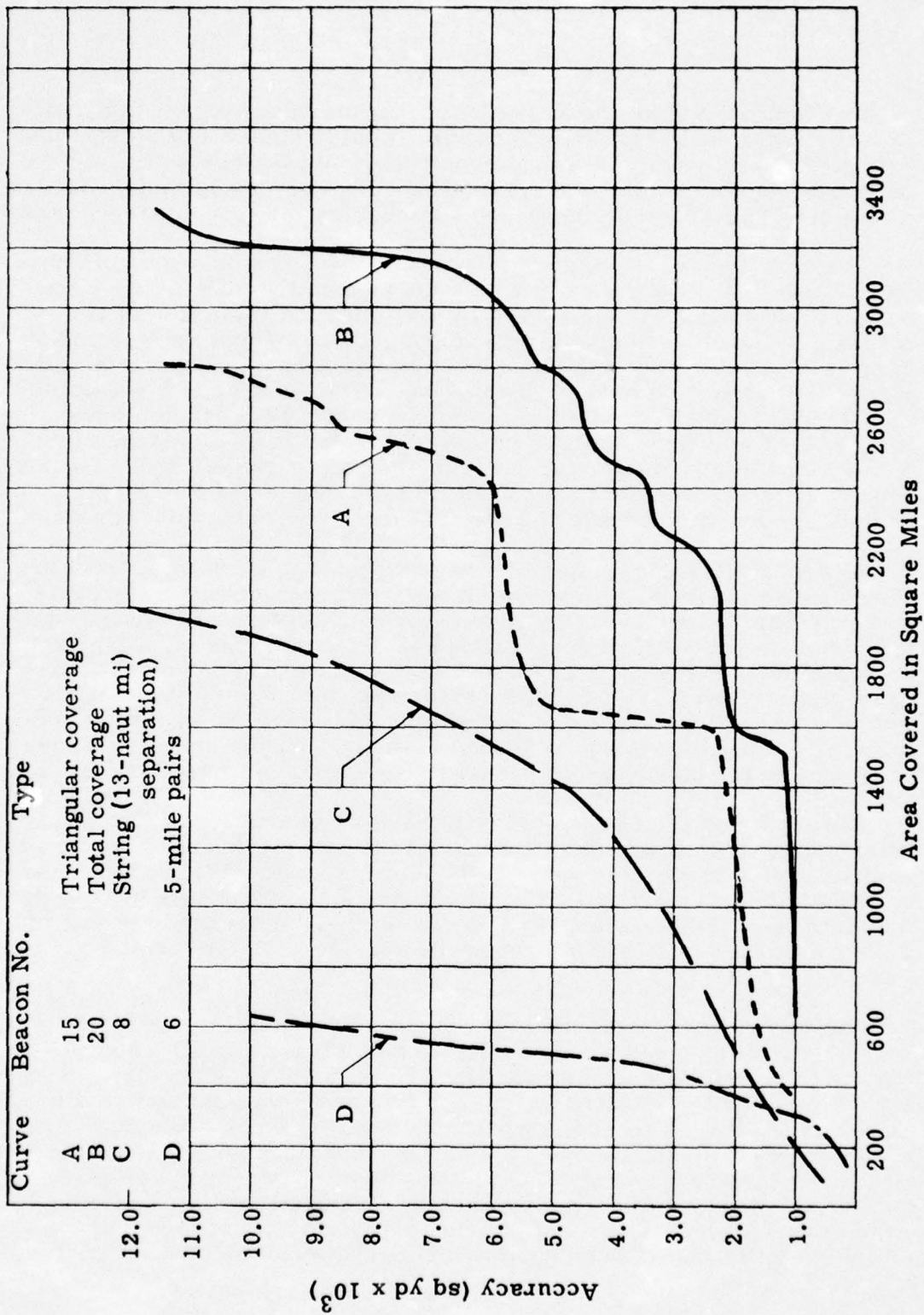

Fig. 56. Area Versus Accuracy

CONFIDENTIAL

NOTE: Numbers 1 to 6

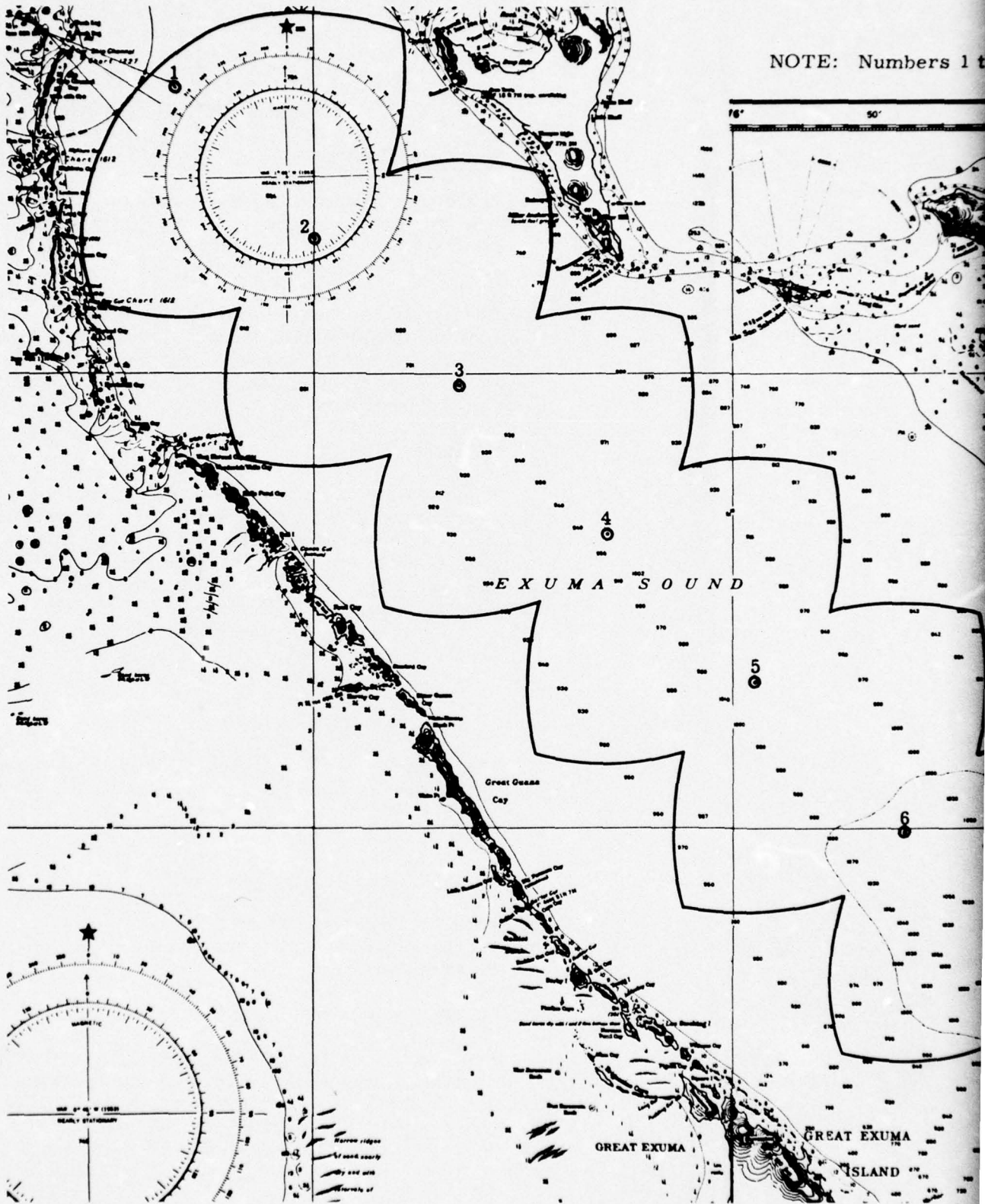

Fig. 57. Coverage Pro

CONFIDENTIAL

ER 12316

NOTE: Numbers 1 through 8 indicate beacon positions.

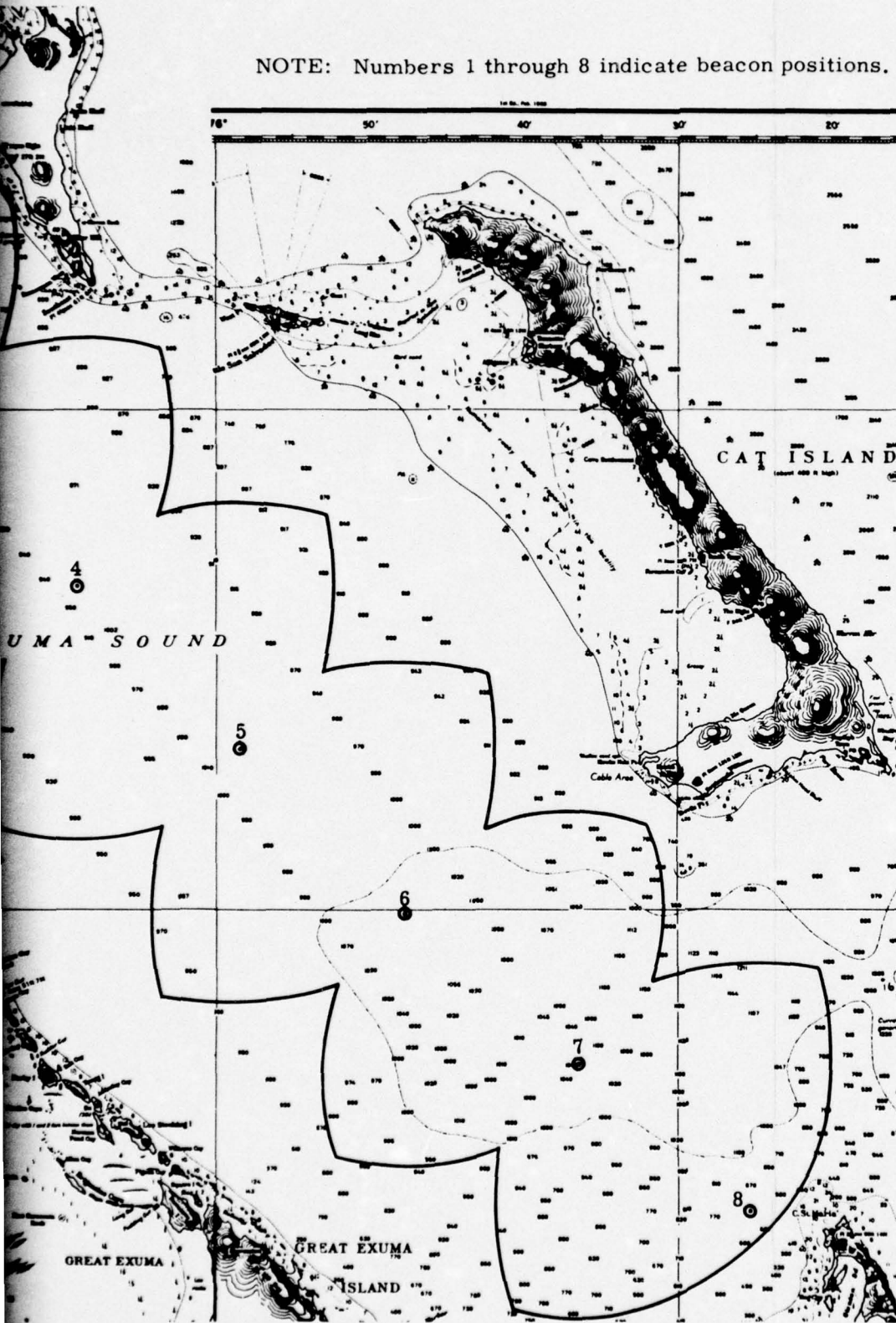

Fig. 57. Coverage Provided by 8 Beacons with a Separation of 13.4 Nautical Miles

2

CONFIDENTIAL

## C. ACCURACY DETERMINATION

1. Source of Errors

The errors associated with the navigational aid range were divided into the following groups.

## a. Sonar errors

These have been considered a function of range and bottom bounce. This is the major error when either or both beacons are greater than 5 mi from the submarine and, consequently, significant reduction in the error of computing the submarine position can only be achieved by reducing this error.

## b. Submarine movement errors

These errors arise because the submarine will not usually be equidistant from any two projectors and, consequently, the signals from two beacons will not arrive at the same time. The submarine motion between the time of arrival of the two signals must be computed. Errors arise in estimating the submarine's speed and course as well as estimating drift due to any water currents present. This is a significant source of error when one of the beacon's signals is received by the direct propagation path and the other is received a significant time later by a bounce path.

## c. Computational errors

This source of error arises from computational inaccuracies. It can be made as small as required and will not be a major error source.

## d. Display errors

This error is present from the charting inaccuracies and the reading and displaying of information on the charts. The display error can be made as small as desired by increasing the chart scale or by use of an automatic navigation computer. The display error will not be a major error source.

## e. Beacon positioning error

The exact location of a beacon will not be known, but can only be determined to the accuracy of the above-water navigational equipment (such as Decca) used during location tests. This introduces errors in determining the submarine position which are significant only if the above-water navigation system errors are not less than the sonar errors.

CONFIDENTIAL  
ER 12316

## 2. Accuracy Model

A total error analysis was made for two beacon separation distances, one of 10 naut mi and the other for 15 naut mi. The position uncertainty area in which the submarine will be (with a probability of 47%) varies from slightly less than 1000 sq yd to 12,000 sq yd. The average is slightly less than 5000 sq yd, which is equivalent to an error circle of less than 40 yd radius. A second method of averaging is to compute the radius of a circle containing the submarine position, with a 39.5% probability (circular normal value of  $\sigma$ ), by the method contained in the following accuracy model. This gives an equivalent average,  $\sigma$ , value slightly greater than 40 yd. Any desired probability can be computed by multiplying the 40 yd by the appropriate square root of the chi-squared value obtained from the accuracy model.

The variation over the Exuma Sound area for the 15-beacon system of equivalent  $\sigma$  value is from less than 15 yd to approximately 75 yd. It appears that the submarine could use the average value for its purposes, whereas greater precision could be obtained in postevaluation done ashore by using the value associated with the submarine's location.

The derivation of the analytical accuracy model to determine the accuracy of the system as a function of the range and station separation of two beacons is described below.

### a. Accuracy model (using two projectors)

Let A and B denote sonar beacons in the navigation aid system as shown in Fig. 58. Let  $R_A$  and  $R_B$  denote the true position of the submarine from beacons A and B, respectively. Let  $\sigma_A$  and  $\sigma_B$  denote the standard deviation of the range measurements about the means  $R_A$  and  $R_B$ , respectively, distributed normally. The area formed by the arcs of the circles  $R_A \pm \sigma_A$  and  $R_B \pm \sigma_B$  is approximately that of a parallelogram with  $A = 4 \sigma_A \sigma_B / \sin \theta$ , where  $\theta$  is the angle between the radii to A and B from the true position. The approximation is an excellent one, provided that  $R_A \gg \sigma_A$  and  $R_B \gg \sigma_B$  and  $\theta$  is not too small.

The error about the true position will now be defined analytically in terms of  $\sigma_A$  and  $\sigma_B$ , provided that the errors are independent. The joint distribution of  $R_A$  and  $R_B$  about the true position is

$$f(R_a, R_b) dR_a dR_b = \frac{1}{2\pi \sigma_A \sigma_B} e^{-\frac{1}{2} \left[ \left( \frac{R_a - R_A}{\sigma_A} \right)^2 + \left( \frac{R_b - R_B}{\sigma_B} \right)^2 \right]} dR_a dR_b$$

where  $R_a - R_A$  denotes the error in  $R_A$  along  $R_A$ , and  $R_b - R_B$  denotes the error in  $R_B$  along  $R_B$ . Let  $r_A = R_a - R_A$  and  $r_B = R_b - R_B$ .

$$f(r_A, r_B) dr_A dr_B = \frac{1}{2\pi \sigma_A \sigma_B} e^{-\frac{1}{2} \left[ \left( \frac{r_A}{\sigma_A} \right)^2 + \left( \frac{r_B}{\sigma_B} \right)^2 \right]} dr_A dr_B$$

Let us now transform the error in position into errors along the  $R_A$  axis now called the  $x$  axis and an axis perpendicular to the  $R_A$  axis, say  $R_\perp$ , now called the  $y$  axis.

Then,

$$\begin{aligned} x &= r_A \\ y &= \frac{r_A \cos \theta - r_B}{-\sin \theta} \end{aligned}$$

This gives

$$g(x, y) dx dy = \frac{|J|}{2\pi \sigma_x \sigma_y \sqrt{1-p^2}} e^{-\frac{1}{2(1-p^2)} \left[ \left( \frac{x}{\sigma_x} \right)^2 - \frac{2pxy}{\sigma_x \sigma_y} + \left( \frac{y}{\sigma_y} \right)^2 \right]} dx dy$$

where:

$$J = \begin{vmatrix} \frac{\partial r_B}{\partial x} & \frac{\partial r_B}{\partial y} \\ \frac{\partial r_A}{\partial x} & \frac{\partial r_A}{\partial y} \end{vmatrix} \text{ or } |J| = |\sin \theta| ;$$

$$\sigma_x^2 = \sigma_A^2 ;$$

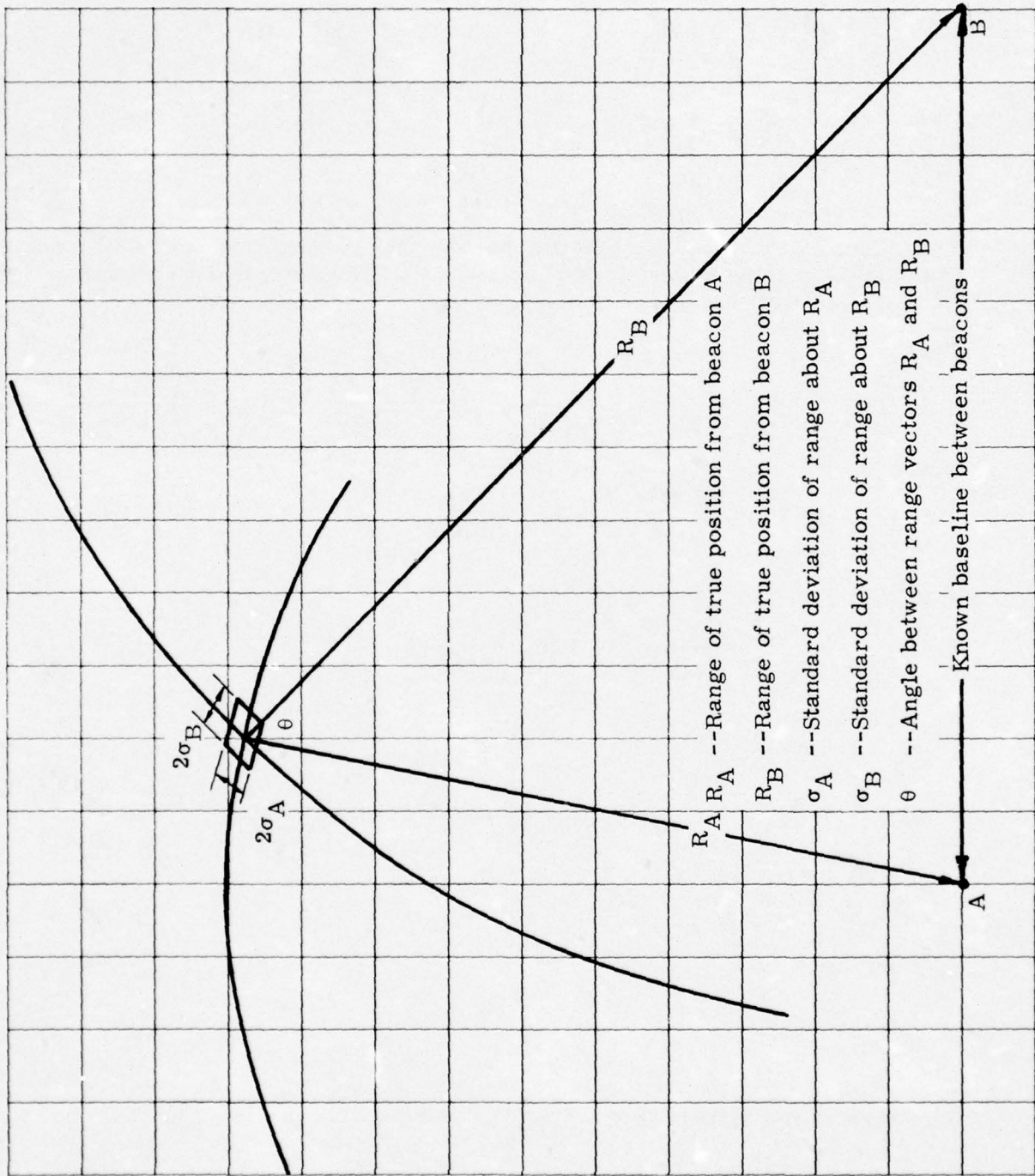

Fig. 58. Beacon Geometry

$$\sigma_y^2 = \frac{\sigma_A^2 \cos^2 \theta + \sigma_B^2}{\sin^2 \theta};$$

$$\rho^2 = \frac{\sigma_A^2 \cos^2 \theta}{\sigma_A^2 \cos^2 \theta + \sigma_B^2}.$$

This bivariate normal distribution can be transformed into one with the variables independent ( $\rho = 0$ ) by rotating the axes  $x$  and  $y$  through an angle  $\theta$ . Call these new axes  $y_1$  and  $y_2$ .

Then,

$$h(y_1, y_2) dy_1 dy_2 = \frac{1}{2\pi \sigma_{y_1} \sigma_{y_2}} e^{-\frac{1}{2} \left[ \left( \frac{y_1}{\sigma_{y_1}} \right)^2 + \left( \frac{y_2}{\sigma_{y_2}} \right)^2 \right]} dy_1 dy_2$$

where

$$(\sigma_{y_1} + \sigma_{y_2})^2 = \frac{\sigma_A^2 \cos^2 \theta}{\sin^2 \theta} + \left( \sigma_A + \frac{\sigma_B}{\sin \theta} \right)^2;$$

and

$$(\sigma_{y_1} - \sigma_{y_2})^2 = \frac{\sigma_A^2 \cos^2 \theta}{\sin^2 \theta} + \left( \sigma_A - \frac{\sigma_B}{\sin \theta} \right)^2;$$

$$\sigma_{y_1} \sigma_{y_2} = \frac{\sigma_A \sigma_B}{\sin \theta}$$

The probability that  $r_A, R_B$  lies inside the ellipse

$$\left( \frac{y_1}{\sigma_{y_1}} \right)^2 + \left( \frac{y_2}{\sigma_{y_2}} \right)^2 = 2\psi^2$$

is given by

$$P = 1 - e^{-\frac{\psi^2}{2}}$$

The area of the ellipse is  $\pi \sigma_{y_1} \sigma_{y_2} \psi^2 = \pi \frac{\sigma_A \sigma_B}{\sin \theta} \psi^2$

The radius of the circle about the true position, having approximately the same portion of the distribution in it is given by

$$R = \psi (0.477 \sigma_{y_1} + 0.523 \sigma_{y_2})$$

for

$$\psi (0.477 \sigma_{y_1} + 0.523 \sigma_{y_2}) \geq Z \sigma_{y_1}$$

where Z is the abscissa of the normal function defined by

$$P \approx \frac{1}{\sqrt{2\pi}} \int_{-Z}^Z e^{-\frac{\mu^2}{2}} d\mu ;$$

otherwise,  $R \approx Z \sigma_{y_1}$  where  $\sigma_{y_1}$  is the semimajor axis of the ellipse.

The values of navigation errors computed using the above approximations are estimated to be less than 3% off from the correct value of the navigation error. This inaccuracy is, of course, considered negligible.

The equations can now be used to estimate the positional accuracy as a function of  $R_A$ ,  $R_B$  and the angle of  $\theta$  between them. This was completed for separation distance between the beacons A and B of 10, 15, 20 and 25 naut mi, and ranges out to 15 naut mi. The results are discussed in Section VC2d. The standard deviation is taken to be a linear function of range and the number of bottom bounces and is given by

$$\sigma_i = R_i + \frac{50}{3} b_i$$

where  $\sigma$  is in yd,  $R$  is in naut mi, and  $b$  is the number of bottom bounces that the propagation undergoes. At present, the propagation paths are taken in 5-mi increments. Thus,  $b = 0$  for direct paths out to 5 mi,  $b = 1$  for a single bottom bounce path from 5 to 10 mi, etc.

The positional accuracy can be defined in a number of ways, one of which is to specify the area about the true position that the computed position will lie within, with a specified probability. This area is elliptical. A second method would be to specify the circle about the true position which the computed position would lie within, with a specified probability. For this case, let  $P$  be the probability of the contour ellipse defined by

$$\left(\frac{y_1}{\sigma_{y_1}}\right)^2 + \left(\frac{y_2}{\sigma_{y_2}}\right)^2 = 2\psi_p^2 ; \text{ where } \sigma_{y_1} \text{ is the semimajor}$$

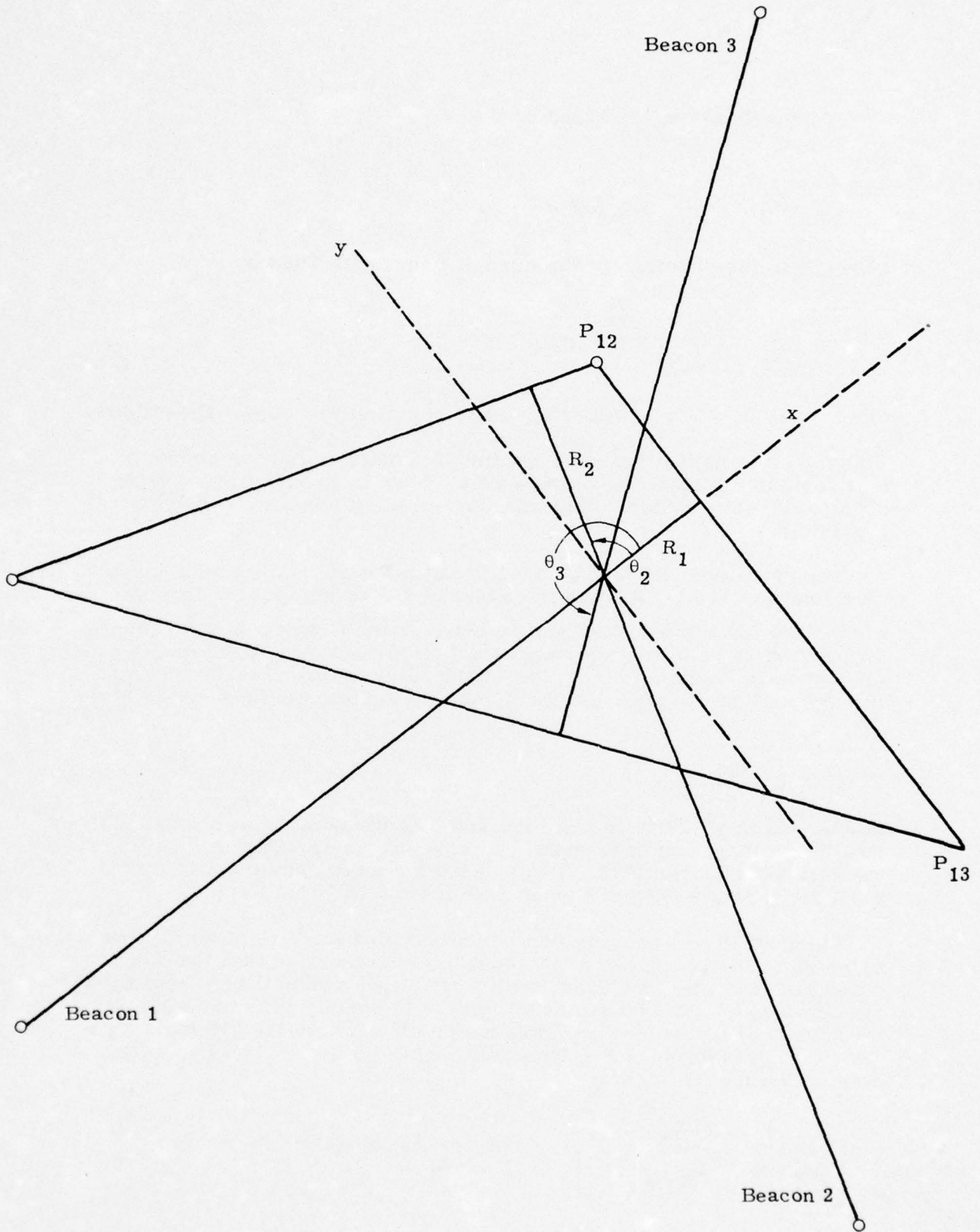

Fig. 59. Three Beacon Geometry

axis of the ellipse. The equivalent circle is given by

$R \approx \psi (0.477 \sigma_{y_1} + 0.523 \sigma_{y_2})$ , when  $\psi (0.477 \sigma_{y_1} + 0.523 \sigma_{y_2}) \geq Z \sigma_{y_1}$ , otherwise  $R \approx Z \sigma_{y_2}$ . A third method would be to specify the average area, or circle, averaging over the entire operational exercise area.

The area within which the position is defined, with a specified probability, is greatest when  $\sigma_A$  and  $\sigma_B$  are large, or when  $\sin \theta$  approaches zero. Consequently, the error can be reduced by decreasing the range and by ensuring that the beacons are positioned such that it is not necessary to compute the position of the submarine from those beacons along whose baseline the submarine lies.

b. Analytical accuracy model (three-beacon)

An analytical accuracy model was also derived to determine the accuracy when the position is estimated by range data from three beacons. Figure 59 is a typical representation of the situation which results when the position of a submarine is estimated by range data from three beacons. Point O is the assumed true position of the submarine, as well as the origin of a system of rectangular coordinates. The latter is defined by taking the X-axis coincident with a line from one of the beacons through the submarine position and then constructing the Y-axis perpendicular at O. For each beacon, the range measurement errors ( $R_i$ ) are taken to be independently and normally distributed about O according to

$$N(O, \sigma_i^2), i = 1, 2, 3, \text{ etc.}$$

(Errors are considered to be positive when the range is overestimated.)  
Angles are measured counterclockwise from the positive X-axis to the line segment representing the positive portion of each distribution.

Normally, the submarine position is estimated as the intersection of two circles having centers at the beacons and radii equal to the range estimates. By way of simplification, the circular areas are replaced by straight lines perpendicular to the endpoints of the estimated range lines and passing through the origin. In general, the result will be a very good approximation, since the distance from a beacon to the submarine is many times larger than the range estimation errors. With three beacons, three separate estimates ( $P_{ij}$ ) of the submarine position will result, each of which is defined by two rectangular coordinates. It is desired to find the joint distribution of the average X and Y coordinates.

The slope of the range lines through the origin is

$$\tan \theta_i, \quad i = 2, 3$$

and zero for  $i = 1$ . (The X axis is coincident with this line and, hence, the angle is zero.) Consequently, the corresponding slopes of the perpendiculars are

$$-\cot \theta_i, \quad i = 2, 3.$$

The coordinates of the end points of the line segments representing the errors are

$$(R_i \cos \theta_i, R_i \sin \theta_i), \quad i = 2, 3$$

and

$$(R_1, 0), \quad i = 1.$$

Since the respective perpendiculars pass through these points, their equations are

$$X = R_1 \tag{1}$$

$$Y = (-\cot \theta_i) X + \frac{R_i}{\sin \theta_i}, \quad i = 2, 3. \tag{2}$$

The three possible estimates of the submarine position are obtained by determining the point of intersection of each pair of these lines.

Case 1. Beacon 1 is a member of the pair. Solving (1) and (2) simultaneously, it is found that

$$X = R_1$$

$$Y = \frac{R_i - R_1 \cos \theta_i}{\sin \theta_i} \quad i = 2, 3.$$

Case 2. Beacons 2 and 3

The simultaneous solution of Eq (2) yields

$$X = \frac{R_3 \sin \theta_2 - R_2 \sin \theta_3}{\sin (\theta_2 - \theta_3)}$$

$$Y = \left( \frac{\sin \theta_3 \operatorname{ctn} \theta_2}{\sin (\theta_2 - \theta_3)} + \frac{1}{\sin \theta_2} \right) R_2 - \frac{\cos \theta_2}{\sin (\theta_2 - \theta_3)} R_3$$

The average coordinates can now be written as

$$\bar{X} = \frac{1}{3} \left[ 2R_1 - \frac{\sin \theta_3}{\sin (\theta_2 - \theta_3)} R_2 + \frac{\sin \theta_2}{\sin (\theta_2 - \theta_3)} R_3 \right]$$

$$\begin{aligned} \bar{Y} = \frac{1}{3} \left[ -(\operatorname{ctn} \theta_2 + \operatorname{ctn} \theta_3) R_1 + \left( \frac{\sin \theta_3 \operatorname{ctn} \theta_2}{\sin (\theta_2 - \theta_3)} + \frac{2}{\sin \theta_2} \right) R_2 \right. \\ \left. + \left( -\frac{\cos \theta_2}{\sin (\theta_2 - \theta_3)} + \frac{1}{\sin \theta_3} \right) R_3 \right] \end{aligned}$$

In order to simplify the notation, the foregoing expressions are written as

$$\bar{X} = \frac{1}{3} (2R_1 + AR_2 + BR_3) \quad (3)$$

$$\bar{Y} = \frac{1}{3} (CR_1 + DR_2 + ER_3). \quad (4)$$

Since the range measurements from the three beacons are independent, the joint density function of the associated three errors is

$$\frac{1}{(2\pi)^{3/2} \sigma_1 \sigma_2 \sigma_3} e^{-\frac{1}{2} \left[ \frac{R_1^2}{\sigma_1^2} + \frac{R_2^2}{\sigma_2^2} + \frac{R_3^2}{\sigma_3^2} \right]}$$

The joint moment generating function of  $\bar{X}$  and  $\bar{Y}$  is, therefore,

$$\begin{aligned} \phi(t_1, t_2) = \int_{-\infty}^{\infty} \int_{-\infty}^{\infty} \int_{-\infty}^{\infty} e^{t_1 \bar{X} + t_2 \bar{Y}} \frac{1}{(2\pi)^{3/2} \sigma_1 \sigma_2 \sigma_3} \\ e^{\frac{1}{2} \left[ \frac{R_1^2}{\sigma_1^2} + \frac{R_2^2}{\sigma_2^2} + \frac{R_3^2}{\sigma_3^2} \right]} dR_1 dR_2 dR_3 \end{aligned}$$

Substituting (3) and (4) and collecting terms in the exponent results in

$$\phi = \int_{-\infty}^{\infty} \int_{-\infty}^{\infty} \int_{-\infty}^{\infty} \frac{1}{(2\pi)^{3/2} \sigma_1 \sigma_2 \sigma_3} \exp \frac{1}{2} \left[ \left( \frac{R_1}{\sigma_1} \right)^2 - \frac{2}{3} (2t_1 + ct_2) R_1 - \frac{2}{3} (At_1 + Dt_2) R_2 + \left( \frac{R_3}{\sigma_3} \right)^2 - \frac{2}{3} (Bt_1 + Et_2) R_3 \right] dR_1 dR_2 dR_3 .$$

Now letting

$$r_1 = \frac{R_1}{\sigma_1} ,$$

or

$$R_1 = \sigma_1 r_1$$

the Jacobian becomes

$$\sigma_1 \sigma_2 \sigma_3 .$$

Hence

$$\phi = \int_{-\infty}^{\infty} \int_{-\infty}^{\infty} \int_{-\infty}^{\infty} \frac{1}{(2\pi)^{3/2}} \exp - \frac{1}{2} \left[ r_1^2 - \frac{2}{3} (2t_1 + ct_2) \sigma_1 r_1 + r_2^2 - \frac{2}{3} (At_1 + Dt_2) \sigma_2 r_2 + r_3^2 - \frac{2}{3} (Bt_1 + Et_2) \sigma_3 r_3 \right] dR_1 dR_2 dR_3$$

Simplifying the notation by setting

$$R = \frac{1}{3} (2t_1 + Ct_2) \sigma_1$$

$$G = \frac{1}{3} (At_1 + Dt_2) \sigma_2$$

$$H = \frac{1}{3} (Bt_1 + Et_2) \sigma_3$$

and

$$\phi = \int_{-\infty}^{\infty} \int_{-\infty}^{\infty} \int_{-\infty}^{\infty} \frac{1}{(2\pi)^{3/2}} \exp - \frac{1}{2} \left[ (r_1^2 - 2Fr_1) + (r_2^2 - 2Gr_2) + (r_3^2 - 2Hr_3) \right] dR_1 dR_2 dR_3$$

Completing the square for each of the three terms in the exponent

$$\begin{aligned} \phi &= \int_{-\infty}^{\infty} \int_{-\infty}^{\infty} \int_{-\infty}^{\infty} \frac{1}{(2\pi)^{3/2}} \exp - \frac{1}{2} \left[ (r_1 - F)^2 + (r_2 - G)^2 + (r_3 - H)^2 - F^2 - G^2 - H^2 \right] dR_1 dR_2 dR_3 \\ &= e^{\frac{1}{2} (F^2 + G^2 + H^2)} \int_{-\infty}^{\infty} \int_{-\infty}^{\infty} \int_{-\infty}^{\infty} \frac{1}{(2\pi)^{3/2}} \exp - \frac{1}{2} \left[ (r_1 - F)^2 + (r_2 - G)^2 + (r_3 - H)^2 \right] dR_1 dR_2 dR_3. \end{aligned}$$

The value of the integral is unity, since the integration is performed over a trivariate normal distribution. Consequently,

$$\phi(t_1, t_2) = e^{\frac{1}{2} (F^2 + G^2 + H^2)}$$

Substitute for F, G, H and factor  $t_1^2$ ,  $t_2^2$  and  $t_1 t_2$  to obtain

$$\begin{aligned} \phi(t_1, t_2) &= \exp \frac{1}{2} \left[ \frac{1}{9} (4_1^2 + A_2^2 + B_3^2) t_1^2 \right. \\ &\quad \left. + \frac{2}{9} (2G_1^2 + AD\sigma_2^2 + BE\sigma_3^2) t_1 t_2 + \frac{1}{9} (C^2\sigma_1^2 + D^2\sigma_2^2 + E^2\sigma_3^2) t_2^2 \right] \end{aligned}$$

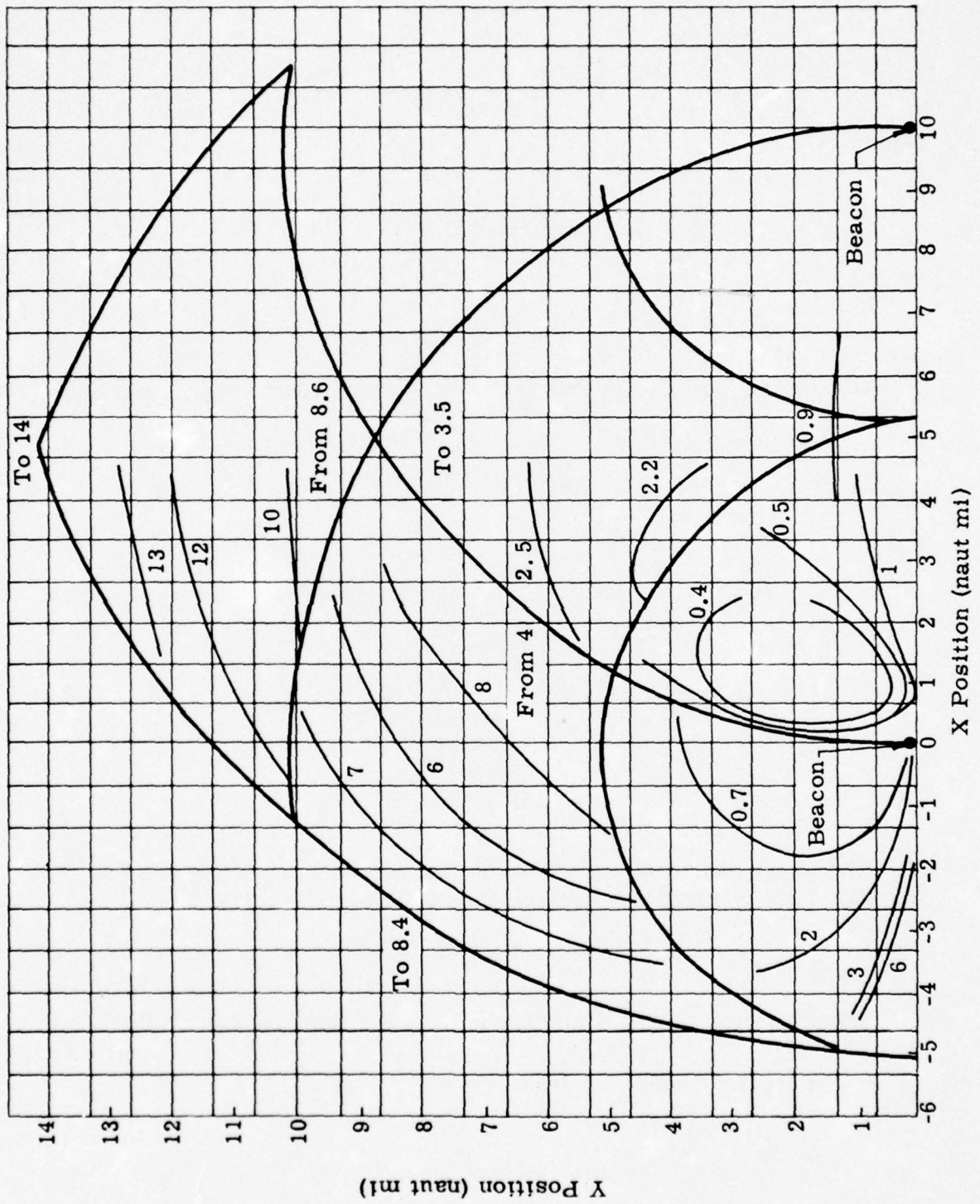

Fig. 60. Accuracy Contours for Beacon Separation of 10 Nautical Miles (sq yd x 10<sup>3</sup>)

But this expression is the moment generating function of a bivariate normal distribution with center at the origin and parameters

$$\bar{X}^2 = \frac{1}{9} (4\sigma_1^2 + A^2\sigma_2^2 + B^2\sigma_2^2)$$

$$\bar{Y}^2 = \frac{1}{9} (C^2\sigma_1^2 + D^2\sigma_2^2 + E^2\sigma_3^2)$$

$$P\sigma_{\bar{X}}\sigma_{\bar{Y}} = \frac{1}{9} (2C\sigma_1^2 + AD\sigma_2^2 + BE\sigma_3^2)$$

from which

$$P = \frac{2C\sigma_1^2 + AD\sigma_2^2 + BE\sigma_3^2}{\sqrt{(4\sigma_1^2 + A^2\sigma_2^2 + B^2\sigma_2^2)(C^2\sigma_1^2 + D^2\sigma_1^2 + E^2\sigma_3^2)}}$$

A numerical evaluation of the above equation showed that little was gained, in terms of accuracy, by using three stations to determine position. For that reason, it will not be treated any further.

c. Monte Carlo accuracy model

A third accuracy model, Monte Carlo simulation for use with a computer, was prepared. This model is treated in detail in Appendix D.

d. Accuracy contours

The accuracy models were evaluated and resulted in accuracy contour curves. These accuracy contour curves in 1000 sq yd of error are shown in Figs. 60 through 63 for beacon separations of 10, 15, 20 and 25 mi, respectively. As stated previously, the base line errors build up too rapidly in all but the 10-mi separation case, and that is the nominal separation used. From this, the 3- and 4-beacon grouping was found to be optimum. Applying the results of Fig. 60 to the placement shown in Fig. 41 gives the accuracy contours shown in Fig. 64. In this case, the navigation error is given in equivalent circular error (CEP). As can be seen, the errors are less than 25 yd over a large percentage of the area. The error exceeds 50 yd only in a very small percentage of the area. The total average error over the entire insonified area is less than 40 yd. In the 15-beacon installations illustrated, the projector groups are positioned to provide the greatest

CONFIDENTIAL

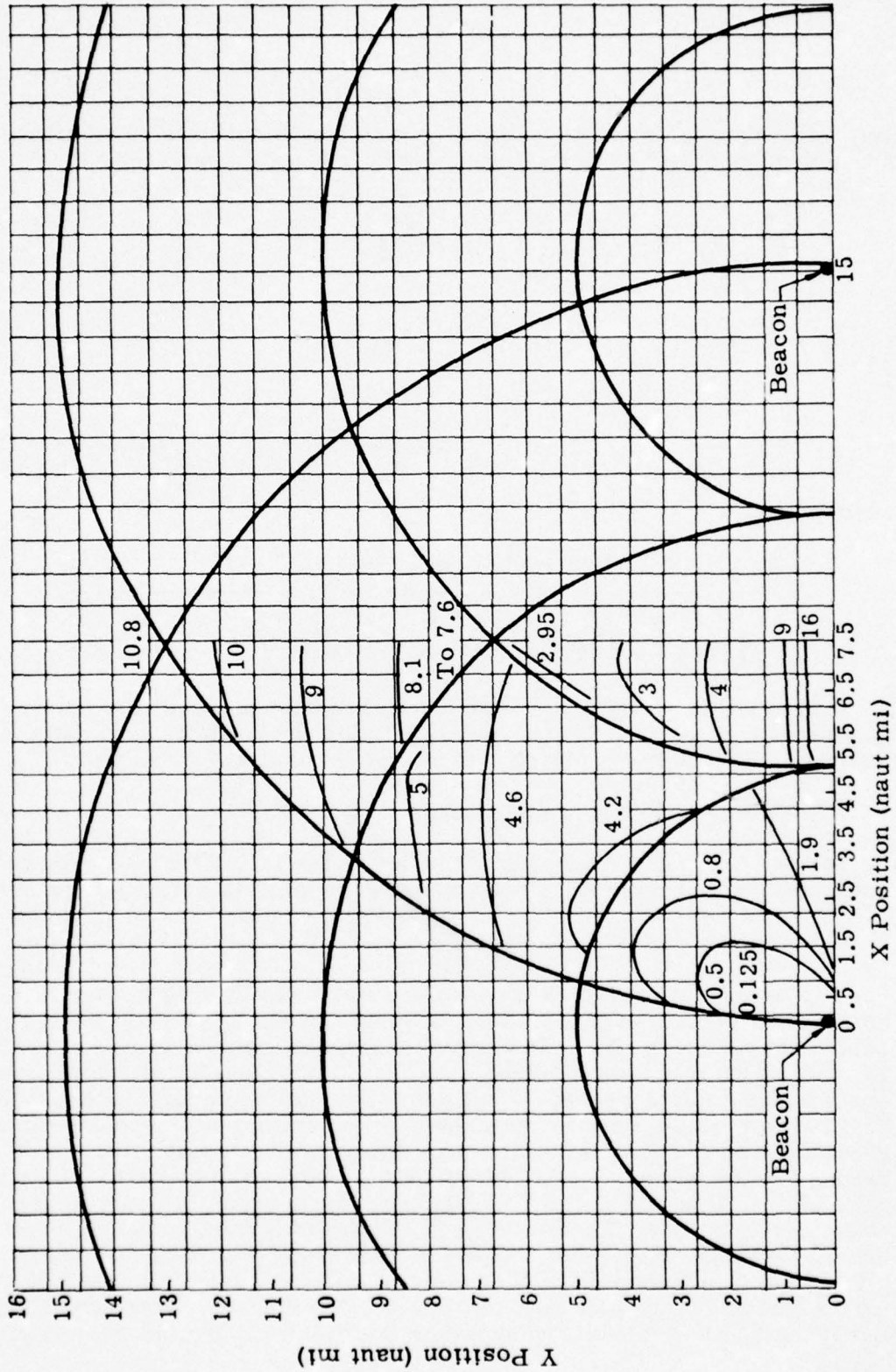

Fig. 61. Accuracy Contours for Beacon Separation of 15 Nautical Miles (sq yd x 10<sup>3</sup>)

CONFIDENTIAL  
ER 12316

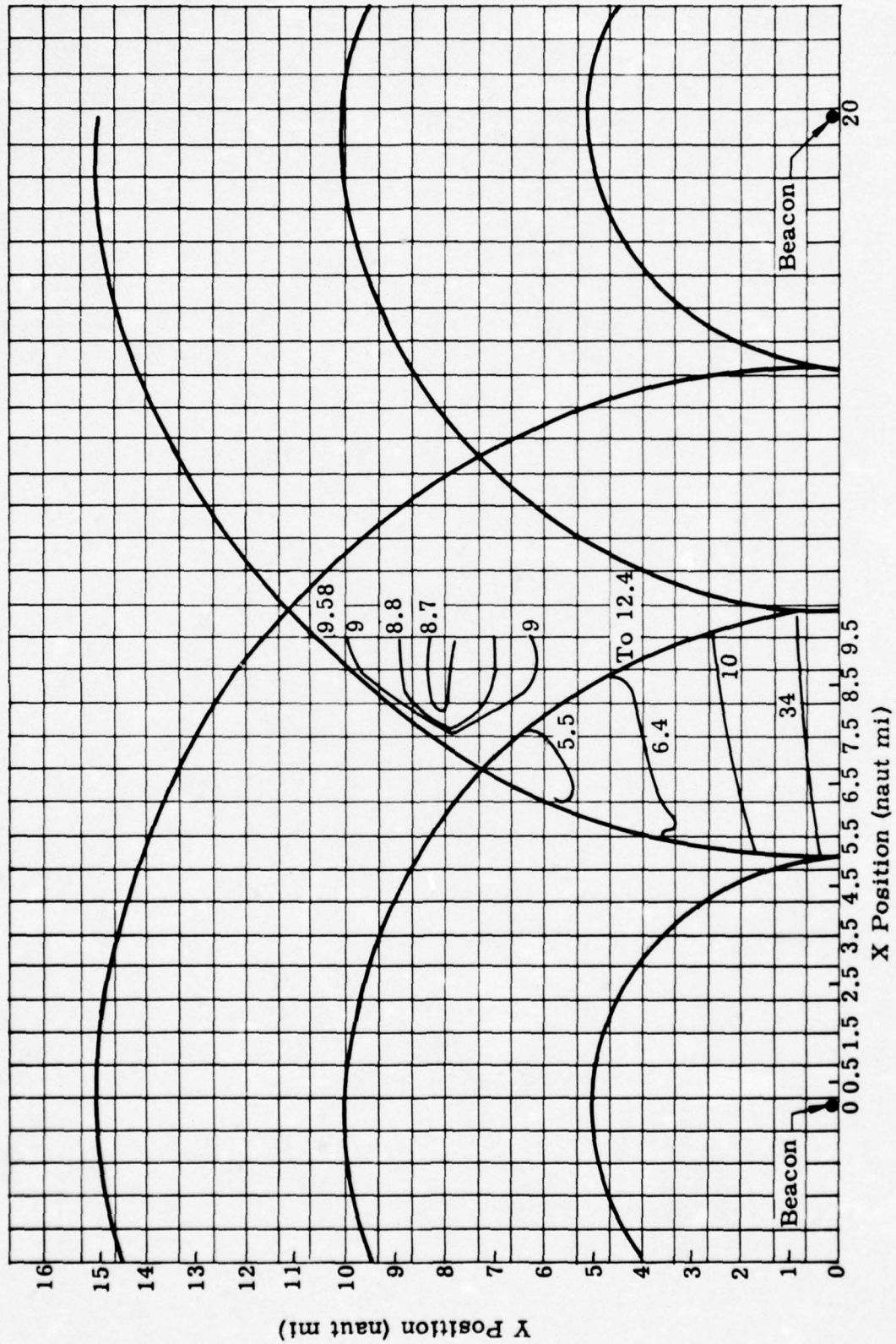

Fig. 62. Accuracy Contours for Beacon Separation of 20 Nautical Miles (sq yd x 10<sup>3</sup>)

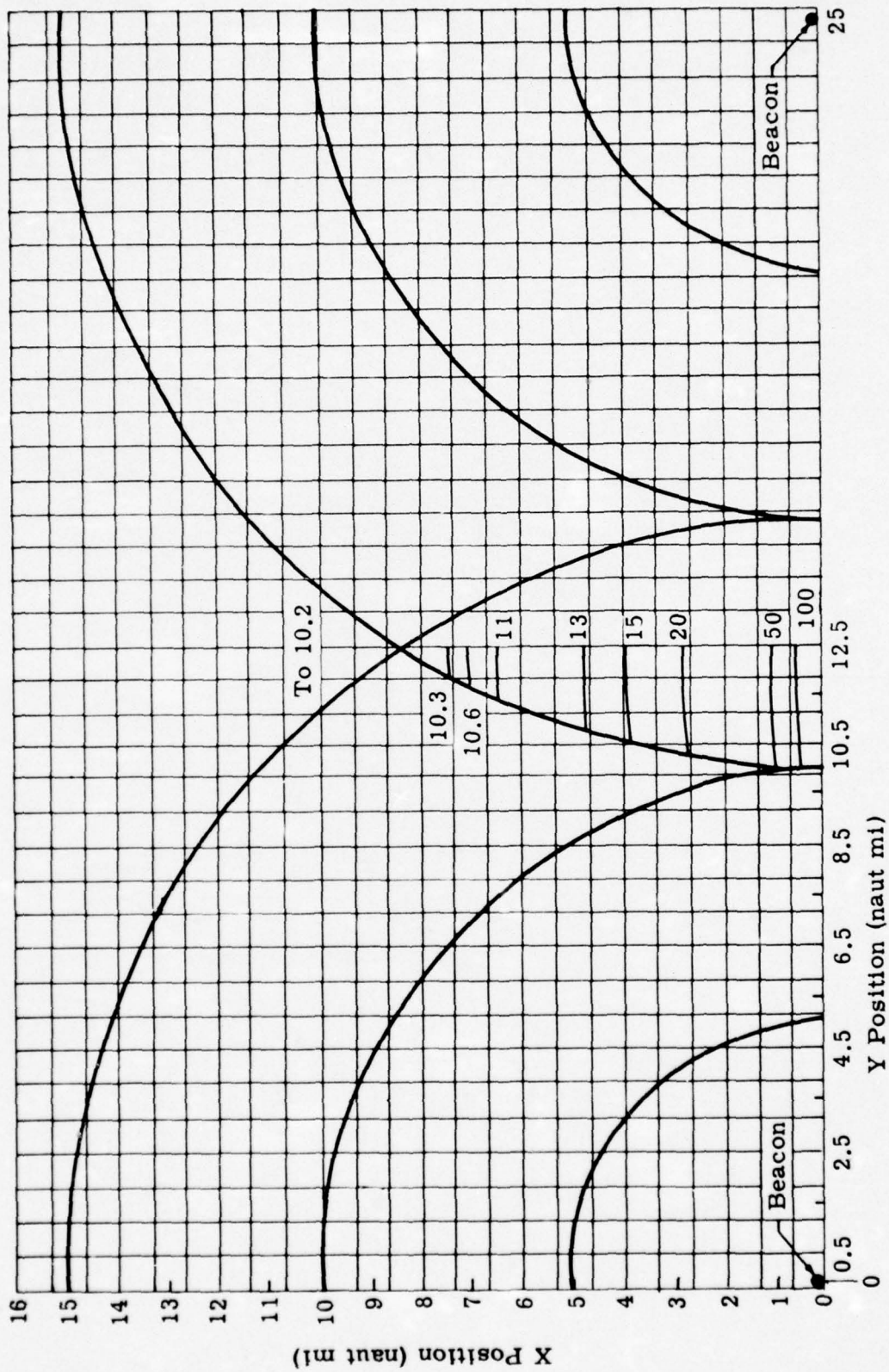
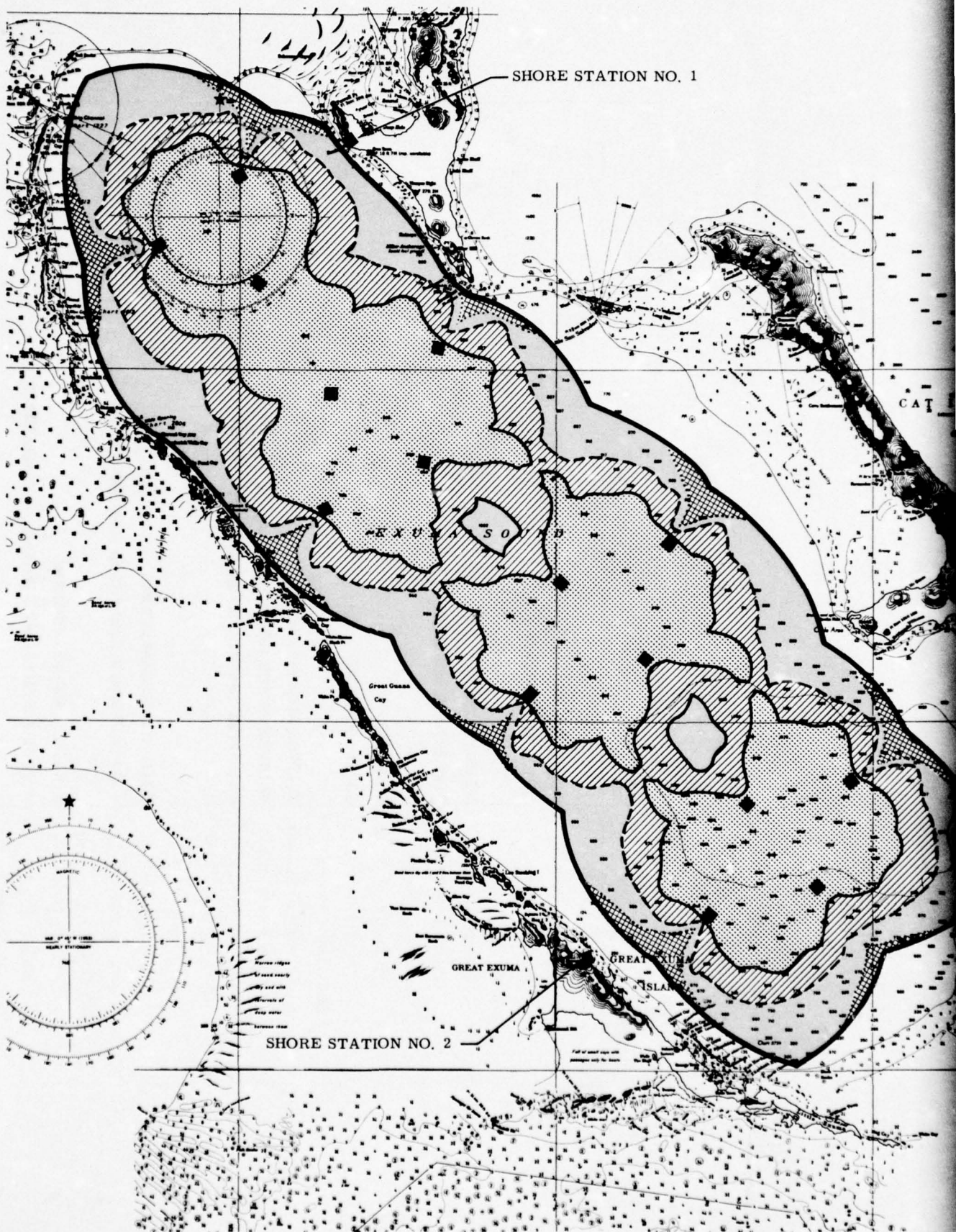

Fig. 63. Accuracy Contours for Beacon Separation of 25 Nautical Miles (sq yd x 10<sup>3</sup>)

CONFIDENTIAL







CONFIDENTIAL

ER 12316

STATION NO. 1

KEY

-  Less than 25 yd error
-  25 to 40 yd error
-  40 to 50 yd error
-  50 to 75 yd error

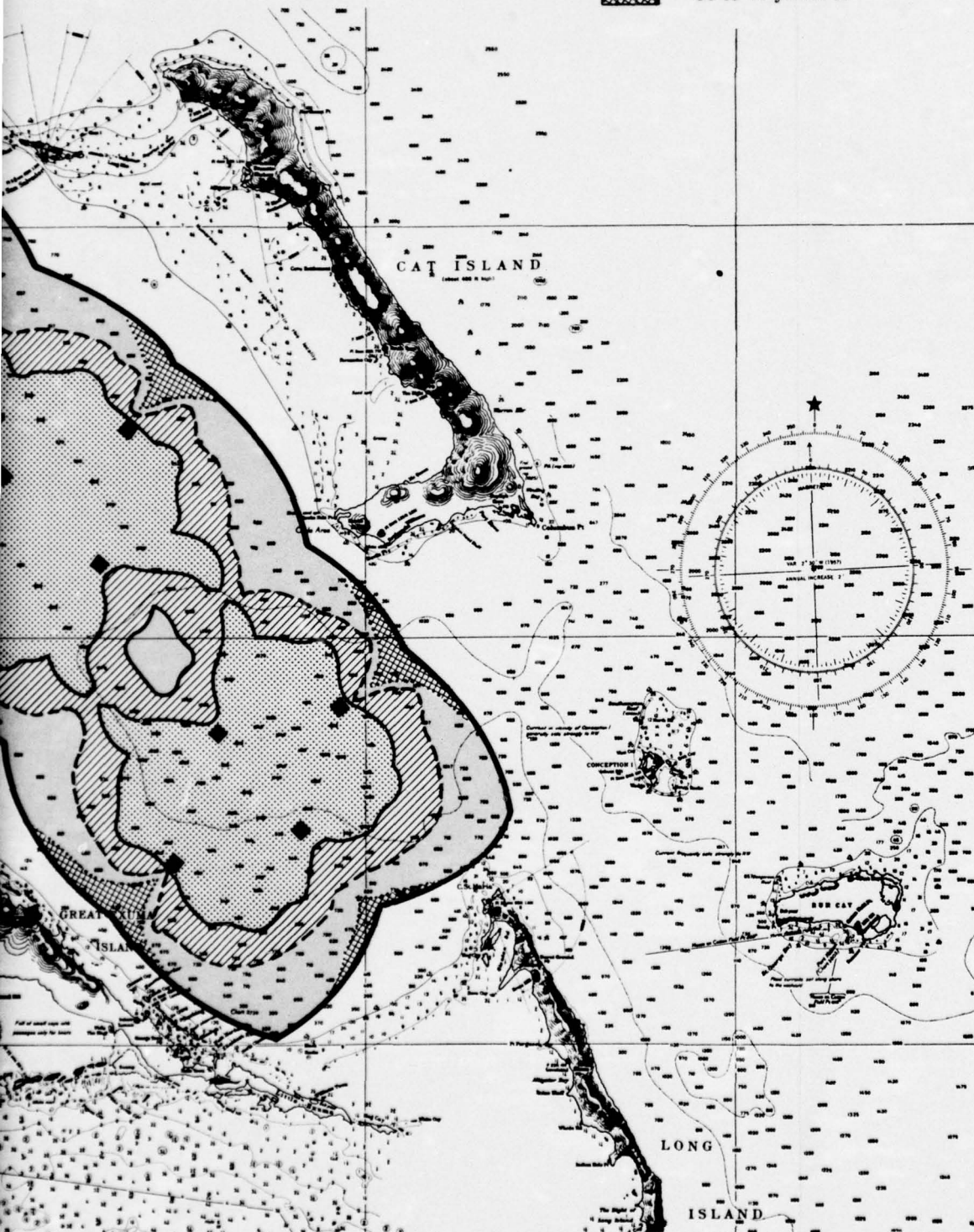

Fig. 64. Fifteen Beacon Accuracy Contour

2

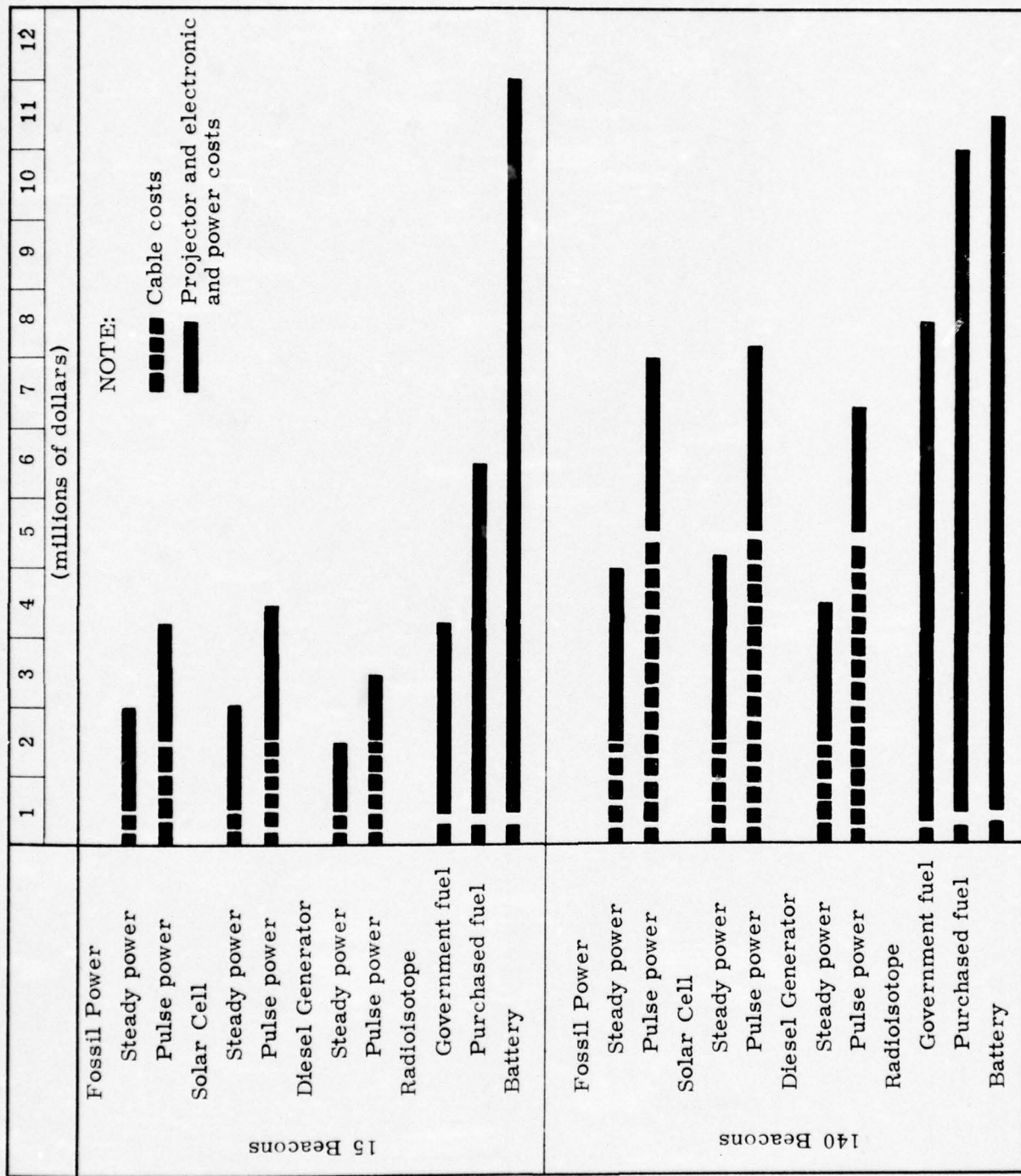

Fig. 65. Costs

possible sonified operating area and the maximum positioning accuracy. Any increase in either the sonified operational area or accuracy would have to be at the expense of the other.

#### D. POWER SUPPLY METHOD AND COST ANALYSIS

The power supply method and system cost have to be considered together since they are completely interrelated. A broad overall cost analysis has been made for three central-type power systems and two individual-type power systems. The resultant costs are shown in Fig. 65. A detailed cost study has been made for a central power system using a diesel generator as a power source. In determining the cable costs, two methods of power (steady power and pulse power) were considered for all power cable installations. The steady power method (dc) has the advantage of using the cheapest cable. However, this method requires the installation of an underwater electronic power driver and power storage pack as a component of the beacon. The pulsating power method (ac) uses more expensive cable and has the decided advantage of eliminating the underwater power driver and power storage pack. The cable cost of the pulsating power system is approximately twice the cable cost of the steady power system. However, it is considered that the reliability of the pulsating power system gives it great advantages over the steady power method. Also, in the steady power system, the cost of the beacons is increased as are the maintenance costs.

It can be seen that the cost of the 5-mi beacons is much higher than the 15-mi beacons and since the 15-mi beacons are feasible, they are obviously the method to use. The advantage of the 15-mi beacon system is not only less initial cost, but it also requires less location tests and maintenance, and results in a simpler computer. Once the 15-mi beacons were selected for the Navaid, a more detailed cost analysis was made for this system. The details of this part of the study follow.

##### 1. Power Supply

A cost analysis was made of the power system using the optimum installation of 15 projectors to determine the most economical method of supplying power to the beacons. Two basic systems, individual and central power systems, were considered.

##### a. Central power system

For a central power system, the following methods of providing power were considered.

Fossil-fueled thermoelectric generator. A centrally located fossil-fueled thermoelectric system will consist of a thermoelectric generator which receives its energy from the combustion of a fuel such as butane and a converter for boosting the voltage. For 15 projectors, the cost of the power supply would be approximately \$416,000. This includes the cost of fuel for one year.

Solar cell system. A centrally located solar cell will include solar cells to convert solar energy to electrical power, a converter to boost the voltage to the required level, and a battery storage system to maintain a constant source of power. Solar cells are considered as a power source, due to the high percentage of sunlight per day in the Exuma Sound area. It is possible to expect about 4,000 hr of sunshine per year. For the 15-projector installations, the cost of a solar cell power supply would be approximately \$614,000.

Diesel generator. This system will consist of a diesel engine and generator unit. At each of the two shore locations, two units would be installed in order to have one on a standby status. A diesel engine is selected for this application because of availability, long life between overhauls and reliability. In addition, the fuel cost is low, about \$350 per year. The cost of four diesel generator units would be \$8,260 plus the above fuel cost.

The individual power system consists of a separate power supply for each underwater beacon. Such a system requires no power cables and can be maintenance free from periods of two to five and possibly ten years, depending on the nature of the power supply.

Radioisotope thermoelectric generator. This system consists of a thermoelectric generator that produces power at a relatively low voltage (10 to 12 volts) and a converter for boosting the voltage to a voltage high enough to charge a small 200-volt battery pack that will store the energy and make it available to the sonar units during peak and surge power demands. This thermoelectric generator will receive its energy from the decay of the radioisotope Strontium-90. The cost of a 100-watt generator is estimated to be about \$62,500. Fifteen generators would be required. The main cost of the power unit will be that of the fuel, which can be as high as \$3 per curie for small amounts and as low as \$0.50 per curie for very large amounts. The processing cost is about \$16,000 to produce 50,000 curies at \$0.32 per curie. However, since this is a government project, it may be feasible to receive the raw fuel at government expense. The total cost of the fuel is based on \$0.32 per curie for processing and \$0.50 per curie for raw fuel. For material and processing, the cost amounts to \$270,000. The total cost of the generator will be \$332,000. To this is added the cost of the converter, \$300, and the cost of the

battery pack, \$1,200. The total cost for the 15-projector system will be \$5,010,000. If the raw fuel is provided by the government, the only cost will be processing the fuel. The total cost for the 15-projector installation with government furnished fuel will be \$2,502,500. The main advantage of this type of power supply is the fact that a thermoelectric generator can be operated for periods in excess of ten years without servicing.

Storage battery system. The storage battery system will consist of a sonar unit with a battery pack having sufficient capacity to deliver the required power to the sonar unit for a maximum period of two years. The cost of a battery to produce the 50 watts required to activate the beacons will be in the neighborhood of \$700,000 per battery. In the 15-projector system, the total cost would be \$11,900,000. The battery for a 15-projector unit is not considered to be very practical, because of the tremendous size and weight that would be required (approximately 13 tons and 220 cu ft).

Reliability and design simplicity are the main advantages of this system. The chief disadvantages besides the weight and size are the need for replacing or servicing batteries every two years and the high initial costs. Table 4 summarizes the power supply costs for the 15-projector installation.

b. Power distribution

In connection with the cable requirements and cable costs required for the central power supply system, two methods of power distribution were considered. In the steady power method (dc), the power is distributed to the installed underwater projector at a constant rate, stored at the beacon and periodically discharged to activate the acoustic projector. This is accomplished by battery storage packs and power drivers at each projector. The second method and the one recommended is a pulse power distribution. This method requires a high central power rating which can be provided by comparatively inexpensive diesel generators, and the required peak power is distributed direct from the central power source by power drivers installed at the power source. Both the power storage pack and the power drivers at the underwater projector are eliminated, thereby improving the overall system reliability.

The pulse power cable is required to transfer power at a higher rating than the steady power method and therefore has a higher cost per mile. However, the pulse power method requires less cable than the steady power method. In the first method, two underwater projectors can be supplied with power using one cable run. In the steady power method a separate cable is run to each projector. In the 15-projector installation, the cable cost of the pulsating power method is approximately three times that of the steady power method.

CONFIDENTIAL

TABLE 4  
Power Supply Costs

<u>Power</u>	<u>\$</u>	<u>Advantages</u>	<u>Disadvantages</u>
Central			
Fossil fueled thermoelectric	\$416,000	Silent operation, reliability	High initial cost Fuel transportation
Solar cell	614,000	Silent operation, reliability No fuel transportation	High initial cost Large storage battery required
Diesel engine-generator	8,260	Very small initial costs Reliability	Fuel transportation Noise level
Individual			
Radioisotope thermoelectric		Operated for period in excess of 10 yr. No fuel transportation. No power cables required.	High initial cost
Government-provided fuel	2,502,500		
Contractor-provided fuel	5,010,000		
Storage battery	11,900,000	Reliability, simple design	Battery replacement every 2 yr. Extremely high initial cost

All central power systems have the disadvantage of requiring power cables to provide power. The individual power systems will also require a cable for synchronization purposes, but the cost of this cable is much less than the cost of a power cable.

Table 5 tabulates the cable costs for both methods of power distribution. The cable cost is the largest single item in installing a submarine navigation aid range.

c. Projector calibration

It is estimated that the calibrating, testing and locating of the beacons after installation would require 90 days and would cost approximately \$342,000 for installing 15 projectors. This cost would be required regardless of which power system was installed.

d. Submarine computer

To accurately and quickly convert the sonic ranges from the installed underwater projectors to an accurate position for navigational purposes, the submarine would require a navigation computer. The computer should be accurate and still be comparatively simple and portable so it can be readily installed in a submarine by submarine personnel. The results obtained from the mathematical accuracy models derived indicate that there is no significant difference in the positioning accuracy obtained using two of the ranges from two or three underwater projectors. Based on this analysis, it is recommended that the submarine computer be designed to compute the submarine position from the best two beacons. It is estimated that the cost to construct two computer models (development and prototype) and a computer analyzer would be \$150,000. Production models would cost approximately \$33,000 each when built in lots of three.

e. Shore installations

Two shore sites would be required to locate the power source for the 15-beacon installation. The two sites selected are Bamboo Point on Eleuthera Island and a site in the vicinity of Stevenson Village on Great Exuma Island. This latter site was selected instead of a site on Stocking Island because it is more accessible and therefore logistic support is more easily supplied. In addition, it reduces the cable requirements for the 8 projectors installed in the southern portion of the sound.

The cost of the shore installation will include the construction cost of a suitable structure, cost of electronic equipment such as ship-to-shore communication equipment and time reference. It is estimated that the shore installation costs for the two sites will be about \$150,000. This does not include living costs beyond the time of installation, location and accuracy tests.

CONFIDENTIAL

TABLE 5  
Power Distribution Cable Costs

<u>Power Supply Project No.</u>	<u>Power Distribution</u>	<u>Distance (mi)</u>	<u>Cost</u>	<u>Protected Cable* (mi)</u>	<u>Cost</u>	<u>Total Cable Costs**</u>
Bamboo Point to beacons 1, 2 and 3	Pulse	41	\$ 234,000	2	\$ 43,500	\$ 277,500
Beacons 1, 2 and 3	Steady	49	73,000	3	20,700	93,000
Beacons 4 to 6 and 5 to 7	Pulse	71	444,400	2	45,000	489,400
Beacons 4, 5, 6, 7	Steady	113	169,500	4	27,600	197,100
Stevenson (Great Exuma Island) to beacons 10 to 8, 11 to 9, 14 to 12 and 15 to 13	Pulse	132	820,800	6	135,000	955,800
Beacons 8, 9, 10, 11, 12, 13, 14 and 15	Steady	217	325,500	12	82,800	408,300
<u>Summary</u>						
15 projectors	Pulse	244	1,499,200	10	223,500	1,722,700
15 projectors	Steady	379	568,000	19	131,100	698,400

\*Protected cable is used from shore site to 100-fathom curve.

\*\*Not including installation.

#### f. Maintenance

The maintenance costs are divided into two categories, the above-water maintenance and the underwater maintenance. The above-water maintenance includes shore installation, power supply system, and electronic equipment installation. The latter includes communication equipment, electronic timers to determine the sequence of the sonic signal from the underwater projectors, electronic power drivers and power storage equipment which is installed ashore. In this case, the maintenance cost over a 10-yr period is estimated to be approximately 25% of the above-water costs.

The underwater maintenance includes the projectors, cable and, if installed, storage power packs and power drivers. For a 10-yr period, the maintenance cost is estimated to be 10% of the underwater costs.

#### g. Cost comparison

Using the most economical installation (diesel generator and direct current cable), the cost to install 15 beacons to insonify 84.5% of the operating area would be approximately 1.9 million dollars (Table 6). Using the recommended, higher reliability system (diesel generators and pulse power cable), the cost is about 2.7 million. To insonify the remaining 15% of the Sound, the cost would be increased about one-third.

The 15-beacon installation has the additional advantage of being flexible, and could be installed in sections. The initial installation would be the 3 beacon group in the northern portion of the Sound, the cost of which would be about \$900,000. Adding another group of four more beacons would increase the cost approximately \$300,000 per group for the steady power system of \$600,000 per group for the pulse power system. To expand the coverage to include the southern portion of the Sound, two additional groups of four beacons would be required, plus an additional shore site at Stevenson (Great Exuma Island). The additional shore site would cost another \$75,000.

### E. GROWTH CAPABILITY

Further effectiveness and operational benefits could be realized from the Submerged Submarine Navigational Aid Range by expanding the existing installation to include monitored electronic consoles installed at the shore locations. The positions of the participating units in an ASW exercise could be transmitted to the console where they could be displayed. The existing power cables to the underwater projectors could be used to transmit the submarine's position to the console. This would require that the submarine periodically transmit

CONFIDENTIAL

acoustically to the beacon and requires additional instrumentation aboard the submarine and at each beacon. Each phase of the exercise being conducted could then be effectively evaluated and unproductive operations eliminated.

The navigation system has a limited capability as a communication system from shore to submarine. The data rate, while limited, would allow the sending of simple messages. The only additional equipment required would be a coder and driver in the shore station and a decoder in the submarine.

TABLE 6  
Navigation Aid Cost for the 15-Beacon Range

	<u>Steady Power</u>	<u>Pulse Power</u>
Shore Installation (2)	\$ 150,000	\$ 156,000
Includes shelters, electronic timers, communication equipment, diesel generators.		
Underwater Installation(15)	245,000	194,000
Includes projectors and electronic drivers and power storage packs for steady power method		
Cable	1,008,000*	1,891,000
Installation-Test Calibration	342,000	342,000
Submarine Navigation Computer	150,000	150,000
Two models (development and prototype), plus a computer analyzer		
Total	\$1,895,000	\$2,733,000

\*Cost includes first three projectors with pulsating power cable and 12 projectors with steady power cable.

CONFIDENTIAL  
ER 12316

VI. SCHEDULE

The original, revised and actual schedules for the various items of the contract are shown below.

	<u>Original</u>	<u>Revised</u>	<u>Actual</u>
Hardware design complete (ship's system)	9/1/61	9/20/61	10/6/61
Hardware construction complete	9/15/61	10/2/61	10/13/61
Bathythermographs available	10/4/61	10/13/61	10/9/61
System test complete	9/29/61	10/13/61	10/14/61
System available for data acquisition	10/2/61	10/14/61	10/15/61
Ship's services available	10/2/61	10/15/61	10/16/61
Analysis hardware design complete	10/2/61	10/20/61	11/10/61
Decca navigation system available	10/4/61	10/15/61	10/15/61
Experimental program start	10/4/61	10/22/61	10/22/61
Analysis hardware available	10/16/61	11/24/61	11/22/61
Experimental program complete	10/23/61	11/6/61	11/4/61
Preliminary power study complete	10/30/61	11/30/61	10/15/61
Preliminary analysis complete	11/10/61	12/15/61	12/15/61
Preliminary operations analysis complete	11/15/61	12/15/61	12/15/61
Analysis hardware modified	12/28/61	1/30/62	2/28/62
Analysis complete	12/28/61	2/15/62	2/28/62
Operations analysis complete	12/28/61	2/15/62	2/28/62
Navigation computer design complete	12/28/61	2/28/62	2/28/62
System specification complete	12/28/61	2/28/62	2/28/62
Final report available	2/28/62	3/30/62	3/30/62

VII. PERSONNEL

The following engineering personnel were utilized on the study program, either part time or full time.

<u>Name</u>	<u>Function</u>
R. Bonner	Program Manager
R. Oberlin	Project Engineer and System and Configuration Design
J. VonSas	Project Engineer (acting, during vacation)
D. Webb	Propagation Analysis and System Design
J. Frech	Circuit Design and Data Analysis
G. Gerlach	Circuit Design
C. Moose	Circuit Design
G. Nussear	Circuit Design
P. Queeney	Operations Analysis
H. Mecklenburg	Operations Analysis
A. Black	Senior Engineer, Ship 2
J. Triemer	Test Engineer and System Configuration
J. Sudey	Data Analysis
S. Lefkov	Interference Study
V. Truscello	Power Supply Study
H. Storrs	Power Supply Study
E. Dunkleberger	Electronic Packaging
F. McNicholas	Electronic Packaging
P. Esposito	Electronic Packaging
L. Miklaszewicz	Electronic Packaging
L. Evans	Mechanical Design
K. Pakulski	Engineering Technician
W. Bialek	Engineering Technician
R. Malone	Engineering Technician

### VIII. RECOMMENDATIONS

As the next step in the implementation of the underwater navigation aid, it is recommended that a program be initiated that will accomplish the following objectives:

- (1) Demonstrate the actual navigation capabilities of the system under a wide range of acoustic conditions.
- (2) Determine and demonstrate the effects of any changes required to the system design.
- (3) Determine the final computer configuration and constants.
- (4) Measure actual attainable navigation accuracies as a function of position about the beacons.
- (5) Determine the suitability of the more complex beacon for future installations.
- (6) Provide a 620-sq mi operational area in the northernmost quarter of Exuma Sound with an underwater navigation estimated average accuracy of 40 yd at depths of 150 to 1500 ft.

These objectives can be accomplished by the following steps and effort:

- (1) Installation of the northern shore station at Bamboo Point, Eleuthera.
- (2) Installation of the three northernmost beacons in Exuma Sound, with one beacon being the more complex type (but switchable to the simpler type upon shore command).
- (3) Location tests to determine beacon location accurately.
- (4) Accuracy tests (conducted with a surface ship using an experimental computer) to demonstrate the navigational accuracies under different conditions, as well as to develop the final computer configuration.
- (5) Development of a prototype computer using the final configuration. This computer will be usable to provide underwater navigation for one submarine.

When these items have been accomplished, the 620 sq mi of the northern end of Exuma Sound will be usable for operational exercises and the specific underwater component configurations for future range expansion will have been determined, as well as the complete navigation computer configuration.

APPENDIX A

SPECIFICATION  
FOR  
SHIP(S) AND SERVICES FOR THE EXUMA SOUND TEST PROGRAM  
MARTIN SPECIFICATION MB-800

1.0 SCOPE. This specification covers the requirements for two (2) ships and the services and labor to be provided to support the Exuma Sound Test Program which is to be conducted in deep water for the collection of oceanographic and acoustic data.

2.0 APPLICABLE DOCUMENTS. There are no other specifications, standards or publications applicable for this document, since this specification is for use only with this procurement.

### 3.0 REQUIREMENTS.

3.1 General. The requirements for two (2) ships and the services and labor described herein are for the acquisition of data as a result of the joint efforts of the Contractor (the Martin Company), and the Subcontractor. The tasks and responsibilities are outlined below:

NOTE: The described procedures are to be considered as a plan to accomplish the objectives herein. Conditions during this program may require deviations from the procedures and are permitted after mutual agreement has been reached by the personnel assigned to the site location representing the Contractor and Subcontractor, where the deviations do not affect cost or delivery. Deviations affecting cost and/or delivery must be mutually agreed upon by the Governmental Contracting Officer and Martin Procurement.

3.2 Charter Operational Time. The Subcontractor shall provide services, labor and facilities required for a period of 21 days to enable Martin Company personnel to acquire oceanographic and acoustic data within the scope of this specification. This time allotted shall include a period of three (3) days for loading, installing, checkout of equipment, off-loading and those necessary functions other than the actual time for the collection of oceanographic and acoustic data.

Eighteen (18) days shall be allotted for the operational time required for data collection including time required for transportation. The ships shall be available in an operational manner for twenty-four (24) hours in every respect to accomplish the objectives herein. It is contemplated that the ships shall be posted for a period of eight (8) hours at each of several stations to enable the collection of the prescribed data.

3.3 Location of Test Sites. The location of sites for various stations for the data collection shall be in the vicinity of Exuma Sound.

CONFIDENTIAL

3.4 Accommodations of Contractor Personnel. The Subcontractor shall furnish all necessary accommodations to personnel (total of 4) of the Martin Company during the period of the contract, to enable them to direct and coordinate the program specified herein. This requirement shall include the provision for arrangements to pick up and drop off personnel at Nassau in September.

3.5 Sea Operation. The ships shall be capable of properly operating in Sea State 3.

3.6 Subcontractor Furnished Items. The Subcontractor shall furnish the following equipment and fulfill the items below for use in attaining the objectives for the collection of oceanographic and acoustic data.

- (a) Ship navigation radar.
- (b) A Fathometer capable of measurement to a depth of 7500 feet in conjunction with a Precision Depth Recorder.
- (c) A communication receiver for WWV signal reception.
- (d) Operator for Decca equipment for Ships 1 and 2.
- (e) For Ship 1, a winch capable of handling\* a 1/4-inch diameter, 5000 ft long armored cable, with an approximate weight of 2500 pounds, and a projector with an approximate weight of 500 pounds.

For Ship 2, a winch capable of handling\* a 1/4-inch diameter, 1500 ft long armored cable, with an approximate weight of 800 pounds, and a Hydrophone Assembly with an approximate weight of 500 pounds.

For Ship 1, the winch shall provide two (2) slip rings for electrical connections.

For Ship 2, the winch shall provide a minimum of two (2) slip rings (four (4) slip rings are preferred) for electrical power connections.

NOTE: The winch shall have the slip rings on the shaft, accessibly placed to make the required electrical power connections.

---

\*"Handling" shall be construed to mean the winch and its associated equipment shall be capable of adequately raising the indicated equipment, moving it across the ship's deck and lowering it in a controlled manner into the water without any damage thereto.

CONFIDENTIAL  
ER 12316

- (f) A communication radio for ship-to-ship and ship-to-shore communications.
- (g) Winch and cable for Bathythermograph, including 60 slides and an operator.
- (h) For Ships 1 and 2, installation provisions shall be made for one (1) relay rack of dimensions 6 ft x 2 ft x 2 ft for each ship and installed by the Subcontractor.

3.7 Martin Furnished Equipment. The Contractor shall supply the Subcontractor with the following equipment.

- (a) Bathythermograph (GFE).
- (b) Projectors.
- (c) All equipment within the relay rack.
- (d) Accessory electronic equipment to operate the equipment within the relay rack.
- (e) Decca Navigational Equipment (GFE).

3.8 Ships' Power Supplies for Electrical Gear. The following power shall be supplied by the ships for utilization by the electronic equipment (see Sections 3.6 and 3.7).

- (a) Ship 1--3 phase, 60 cps, 440 volts ac, 15 kva  $\pm$  10% (when the main winch is in operation, this power supply shall not be utilized).

Single phase, 60 cps, 115-v ac  $\pm$  10%, 20 amp  $\pm$  10%.

- (b) Ship 2--Single phase, 60 cps, 115-v ac  $\pm$  10%, 20 amp,

3.9 Subcontractor Personnel. Other than the Martin personnel (total 2) for each ship to operate the equipment provided by the Martin Company, the Subcontractor shall provide the personnel required to accomplish all activities within the scope of this specification.

3.10 Return of Equipment. Upon completion of the program, all equipment (including GFE and that furnished by Martin) shall be returned to the source of title ownership.

3.11 Date of Program Performance. The program shall be executed and performed in October and November 1961.

CONFIDENTIAL

3.12 Area of Program Performance. The performance of the applicable requirements within this specification shall be in the vicinity of the Exuma Sound, Bahama Islands. The pickup and dropoff of personnel shall be performed at Nassau.

3.13 The Responsibilities of the Subcontractor. The responsibilities of the Subcontractor are defined by the requirements within this specification to include the required arrangements or services thereto, but not limited to:

- (a) The receipt and installation of experimental apparatus.
- (b) Participation in the selection of the suitable water for testing.
- (c) The examination of experimental schedules for the areas in question to be certain that there will be no conflict with other groups.
- (d) The obtainment of necessary permission to conduct experiments from appropriate authorities to include U.S. and foreign civil and military authorities.
- (e) The making of all applicable arrangements with Customs, Immigration, Consular, and Harbor authorities, both U.S. and foreign.
- (f) The movement of personnel and equipment to and from the test sites.
- (g) The provision of complete logistic support for experiments at sea, including arrangements for fueling and reprovisioning at sea or at foreign ports when required.
- (h) The provision of well ventilated (preferably air-conditioned) areas for electronic equipment and living quarters.
- (i) The obtainment of suitable quarters on shore for scientific personnel when required.
- (j) The removal from vessels, packing, and shipping of experimental apparatus and other equipment upon completion of experiments.
- (k) The Subcontractor shall provide any materials or services required to fulfill the specification requirements herein.

CONFIDENTIAL  
ER 12316

**APPENDIX B**

OPERATIONAL PLAN

Part 1. Summary Operational Plan

Part 2. Detailed Operational Plan

PART 1. SUMMARY OPERATIONAL PLAN

Omega			Earl of Desmond		
Reference: Martin Spec MB-800, Ship 1			Reference: Martin Spec MB-800, Ship 2		
Activity	Dates	Total Days	Activity	Dates	Total Days
Loading (Norfolk)	16,17 Oct	1	Loading (Annapolis)	14,15 Oct	2
En route (to Nassau)	17, 18, 19, 20,21 Oct	5	En route (to Nassau)	16,17,18, 19,20,21 Oct	6
Loading (Nassau)	22 Oct	1	Loading (Nassau)	22 Oct	1
En route (to Exuma)	23 Oct	3/4	En route (to Exuma)	23 Oct	3/4
At Exuma	23,24,25, 26,27,28 Oct	5-1/4	At Exuma	23,24,25, 26,27,28 Oct	5-1/4
En route (to Nassau)	29 Oct	3/4	En route (to Nassau)	29 Oct	3/4
Loading (Nassau)	29,30 Oct	1/2	Loading (Nassau)	29,30 Oct	1/2
En route (to Exuma)	30 Oct	3/4	En route (to Exuma)	30 Oct	3/4
At Exuma	30,31 Oct 1,2,3,4 Nov	5-1/4	At Exuma	30,31 Oct 1,2,3,4 Nov	5-1/4
En route (to Nassau)	5 Nov	3/4	En route (to Nassau)	5 Nov	3/4
Off loading (Nassau)	6 Nov	1	Loading (Nassau)	6 Nov	1
			En route (to Annapolis)	7,8,9,10, 11,12 Nov	6
			Off loading (Annapolis)	13 Nov	1
TOTALS		22	TOTALS		31

CONFIDENTIAL

## PART 2. DETAILED OPERATIONAL PLAN

<u>Event No.</u>	<u>Date</u>	<u>Location</u>	<u>Ship</u>	<u>Event</u>
1	14, 15 Oct	Annapolis	Earl of Desmond	Load all required equipment.
2	16, 17, 18, 19, 20, 21 Oct	En route to Nassau	Earl of Desmond	Depart Annapolis for Nassau at 0500 on 16 Oct.
3	16, 17 Oct	Norfolk	Omega	Load 12,000 ft of cable from U.S.S. Hunting. Terminate lowering end of cable in termination fitting and test cable by applying a 500-lb static load on the fitting. Thread the other end of the cable into the equipment room. Load all required equipment and prepare ship for departure on 17 Oct.
4	17, 18, 19, 20, 21 Oct	En route to Nassau	Omega	Depart Norfolk for Nassau at 1700 on 17 Oct. Splice cable to projector en route.
5	21, 22 Oct	Nassau	Omega	Arrive in Nassau and pick up Martin personnel, R. Oberlin and E. Pakulski. Mr. Oberlin will coordinate all test activities as senior scientist. While at dockside, replenish supplies, install Decca equipment, and lower projector over the side, securing it firmly under the bow.
6	21, 22 Oct	Nassau	Earl of Desmond	Arrive in Nassau and pick up Martin personnel, A. Black and J. Triemer. Mr. Black will coordinate activities aboard ship 2 as senior scientist. While at dockside, replenish supplies and install Decca equipment.
7	23 Oct	En route to Exuma Sound	Omega and Earl of Desmond	Depart for Exuma Sound at 0600 on 23 Oct.
8	23, 24, 25 Oct	Exuma Sound (Sta No. 1)	Omega	Arrive at Exuma Sound at 2000. Take and hold position on Latitude 24°43'39", Longitude 76°36'42".
9	23, 24, 25 Oct	Exuma Sound (Sta No. 1)	Earl of Desmond	Arrive at Exuma Sound at 2000. Take position Latitude 24°52'51", Longitude 76°46'36" in 200 ft of water.
10	23 Oct	Exuma Sound	Omega	Lower projector to a distance of 100 ft from the bottom. Start tests by transmitting 1-sec FM pulses (1.1 to 1.6 kc) at a 10-sec repetition rate at maximum power. Type of modulation, frequency, repetition rate and pulse width are to be recorded along with ship's position, projector depth, bottom depth and projector level. A replica of the acoustic pulse is to be transmitted, via radio, to the Earl of Desmond. Bathythermographs are to be taken every 12 hr.

CONFIDENTIAL  
ER 12316

## PART 2. (continued)

Event No.	Date	Location	Ship	Event
11	23,24,25 Oct	Exuma Sound (Sta No. 1)	Earl of Desmond	Lower hydrophone to a depth of 100 ft. A recording of 20 pulses of energy received both by radio and acoustically, together with records of time, water depth, hydrophone depth and ship's position, is to be made. Repeat this procedure at 1-mi intervals from the Omega along a course of 180° True. Recordings are to be made with the hydrophone at depths of 100, 200, 400, 800 and 1500 ft, as the bottom permits. Continuous visual monitoring of the received pulses is to be made using the visicorder. Wherever the start of the pulse can no longer be determined within an accuracy of 10 ms, the Omega is to be so notified.
12	23, 24,25 Oct	Exuma Sound (Sta No. 1)	Omega	At every 5-mi interval from the Earl of Desmond, repeat Event 9, except use a pseudorandom pulse 0.310 sec long (1.1 and 1.6 kc signals).
13	23,24,25 Oct	Exuma Sound (Sta No. 1)	Earl of Desmond	Repeat Event 10 except change the test interval to every 5 mi from the Omega. This procedure is to be continued until a range of 30 mi is reached, or until the pulses can no longer be distinguished aurally.
14	23,24,25 Oct	Exuma Sound (Sta No. 1)	Omega	At every 3rd and 5th mi interval, i.e., 3rd, 5th, 8th, 10th, etc., from the Earl of Desmond, repeat Event 9, except use a 2.5-sec FM pulse (700 cps to 2 kc) and a depth of 100 ft only.
15	23, 24,25 Oct	Exuma Sound (Sta No. 1)	Earl of Desmond	Repeat Event 10 except change interval to every 3rd and 5th mi as in Event 14. These tests are to be conducted at only one hydrophone depth of 1500 ft. Bathythermographs are to be taken at every 3rd and 5th mi interval. This procedure is to be repeated until a range of 30 mi is reached or until the pulse can no longer be distinguished aurally.
16	25,26 Oct	Exuma Sound (Sta No. 1A)	Omega	Hold position Latitude 24°42'39" Longitude 76°36'42", lower the projector to the bottom and transmit and record signals as outlined in Event 9. Signals are to be transmitted for a 10-min interval every hour over a 24-hr period, and bathythermographs taken every 4 hr.
17	25,26 Oct	Exuma Sound (Sta No. 1A)	Earl of Desmond	Take and hold position Latitude 24°22'31" Longitude 76°13'3". During each 10-min test interval, record signals in same manner described in Event 10 for a hydrophone depth of 100 ft only. Continue tests for a 24-hr period, maintaining original ship's position as closely as possible. During each 10-min interval, record ship's position readings every 30 sec. Bathythermographs are to be taken every 4 hr. At the end of the test, the Decca representative is to be notified to move the Decca Hifix to south Exuma Sound.

CONFIDENTIAL

## PART 2. (continued)

<u>Event No.</u>	<u>Date</u>	<u>Location</u>	<u>Ship</u>	<u>Event</u>
18	23,24,25 Oct	Exuma Sound (Sta No. 2)	Omega	Omega to take and hold position Latitude 24°47'09", Longitude 76°32'49" and repeat Events 10, 12 and 14.
19	23,24,25 Oct	Exuma Sound (Sta No. 2)	Earl of Desmond	Earl of Desmond to take position in 200 ft of water at approximate Latitude 24°55'05", Longitude 76°32'49" and repeat Events 11, 13 and 15.
20	29 Oct	En route to Nassau	Omega and Earl of Desmond	Return to Nassau for replenishing of supplies.
21	29,30 Oct	Nassau	Omega and Earl of Desmond	Replenish supplies and depart for Exuma Sound at 0600 on 30 Oct.
22	30,31 Oct	Exuma Sound (Sta No. 7)	Omega	Arrive at Exuma Sound at 2000. Take and hold position Latitude 24°11'06", Longitude 76°15'54" and repeat Events 10, 12 and 14. Use Decca equipment as soon as it is operable.
23	30,31 Oct	Exuma Sound (Sta No. 7)	Earl of Desmond	Arrive at Exuma Sound at 2000. Take position Latitude 24°07'56" Longitude 76°21'09" and repeat Events 11, 13 and 15. During these tests, proceed along a course of 060° True from the Omega.
24.	1,2 Nov	Exuma Sound	Omega	Take and hold position Latitude 23°45'33" Longitude 75°15'18" and repeat Events 10, 12 and 14.
25	1,2 Nov	Exuma Sound (Sta No. 13)	Earl of Desmond	Take position Latitude 23°41'45" Longitude 75°57'12" and repeat Events 11, 13 and 15. During these tests, proceed along a course of 60° True from the Omega.
26	3,4 Nov	Exuma Sound	Omega	Take and hold position Latitude 23°40'48" Longitude 75°36'21" and repeat Events 10, 12 and 14.
27	3,4 Nov	Exuma Sound (Sta No. 15)	Earl of Desmond	Take position Latitude 23°32'12", Longitude 75°27'00" and repeat Events 11, 13 and 15. During these tests, proceed along a course of 315° True from the Omega.
28	5 Nov	En route to Nassau	Omega and Earl of Desmond	At the completion of the above tests, the two ships are to return to Nassau.
29	6 Nov	Nassau	Omega and Earl of Desmond	Off-load all test equipment and special cables from the Omega onto the Earl of Desmond. This terminates the charter of the Omega. Martin personnel are to return to Baltimore.
30	7,8,9,10, 11,12 Nov	En route to Annapolis	Earl of Desmond	Proceed to Annapolis with all experimental equipment.
31	13 Nov	Annapolis	Earl of Desmond	Off-load all special equipment and cables onto Martin trucks. This terminates the charter of the Earl of Desmond. Martin trucks are to return to Baltimore.

CONFIDENTIAL  
ER 12316

CONFIDENTIAL

C-1

APPENDIX C

SUBMERGED SUBMARINE NAVIGATION AID  
SPECIFICATION

CONFIDENTIAL  
ER 12316

## 1.0 OBJECTIVE

The purpose of this document is to cover the requirements for the design and installation of an underwater navigation aid for submarines in the Exuma Sound area with an accuracy of 50 yd (CEP) at depths of 150 to 1500 ft and at speeds of 30 kn or less.

## 2.0 SCOPE

This document covers the following parts and phases of the system:

- 2.1 Shore stations (2)
- 2.2 Deep stations (15) including installation, interconnecting cable and location tests
- 2.3 Navigation computer including accuracy tests
- 2.4 Computer analyzer
- 2.5 Navigation recorders
- 2.6 Handbooks
- 2.7 Spares

## 3.0 GENERAL REQUIREMENTS

All equipment must be built to best commercial practice and to operate from 110 volts  $\pm$  10%, 60  $\pm$  5 cps unless specified otherwise. Solid-state design is required for the navigation computer and preferred for the shore equipment. The navigation computer, each computer analyzer, and navigation recorders must be built in sections weighing less than 50 lb and must pass through a 24-in. circular opening.

## 4.0 SPECIFIC REQUIREMENTS

### 4.1 Shore Station

Two shore stations are required. Station No. 1 is to be located at Bamboo Point, Eleuthera (24° -44' -30" N, 76° -19' -30" W). Station No. 2 is to be located at Stevenson, Great Exuma Island (23° 39' 30" N 75° 56' 45" W). Each station is to consist of the following:

CONFIDENTIAL

#### 4.1.1 Concrete Block Building

One concrete block building consisting of two rooms, each 12 x 12 x 8 ft high, will be required. One room will serve as the equipment room and is to be air conditioned. The other room, a diesel generator room, must be provided with adequate ventilation. Each room is to have at least two windows and one door plus one interconnecting door. The door in the diesel generator room is to be sufficiently large to permit installation and removal of the diesel generators. Fresh water and toilet facilities shall be provided. The building is to have a concrete slab floor covered with asphalt tile or similar material. A wooden roof with builtup tar covering or similar material is required.

#### 4.1.2 Power Supply

The power supply will consist of one 15-kw 110/220/416 volt 3-phase 60-cps diesel generator with a frequency regulation of  $\pm 5$  cps or less and a voltage regulation of  $\pm 10\%$  or less (no load to full load). Motor starting and running controls are to be included as well as protective circuit breakers. Battery start and a battery charging generator and regulator are to be provided. Sufficient oil capacity for one month's operation is also to be provided.

#### 4.1.3 Coding Generator

One coding generator capable of generating four types of swept frequency pulse waveforms, hereafter known as A, B, C and D coding, will be provided. These codings have the following characteristics:

- A 50-ms pulse swept linearly in frequency from 1.8 to 2.0 kc
- B 50-ms pulse swept linearly in frequency from 2.0 to 1.8 kc
- C 50-ms pulse swept linearly in frequency from 2.2 to 2.4 kc
- D 50-ms pulse swept linearly in frequency from 2.4 to 2.2 kc

Pulse width is to be  $50 \pm 2\frac{1}{2}$  ms and the instantaneous frequency is to be within  $\pm 5$  cps of the correct value.

The coding generator is to take timing pulses (source to be specified in a later section) at rates of 2 pulses per minute and 20 pulses per second and generate a code at the beginning of each 1/2-min interval and every 0.1 sec for a total of 12 codes. The timing accuracy

of the start of each code pulse is to be within 1 ms of the timing pulses. One switch is to be provided for selection of off, manual or automatic timing. A pushbutton shall be provided to initiate manual timing when it is selected. Twelve switches are to be provided, each of which has 5 positions: A, B, C, D and OFF. The first switch selects the code used for the first pulse; the second switch selects the code for the second pulse, etc.

The timing generator is also to provide 12 gating outputs in synchronism with the above 12 codes. Each gating output is to start within 10 to 25 ms of the end of the preceding pulse and last a similar amount past the end of its own code pulse. In the case of the first code, the 12th pulse of the previous sequence shall be considered the preceding pulse. A 13-position selector switch shall be provided that turns on only one of the gating outputs, 1 through 12, as the switch is turned to the corresponding number. The 13th position of the switch is to be labeled "auto" and provides the automatic gating sequence in synchronism with the 12 codes.

#### 4.1.4 Digital Time Reference

A digital time reference is required (at Station No. 1 only) and shall have the following characteristics:

- Time accuracy: Less than 3-ms total drift and setting error in 24 hr.
- Calibration: Must provide for calibration by WWV every 24 hr.
- Output: Pulses every 50 ms starting on the half minute and pulses every 1/2 min on the half minute. Timing error is to be  $\pm 1$  ms or less, not including clock drift for a 24-hr period or more.
- Standby power: Standby battery power is to be provided to the oscillator and counting circuits automatically in case of failure of the main power.
- Indication: Digital indication of hours, minutes and seconds based on the 24-hr clock is to be provided in visual form.

#### 4.1.5 Power Driver

One power driver capable of supplying the various codes, as supplied by the timing chassis, at a level of 20 kw into the deep cable (to be described later) is required. The driver is to use the 440-volt 3-phase 60-cycle voltage for its power input. The output level shall be variable from 1 to 20 kw, either continuously or in 2-db steps. In addition, the output shall switch to the appropriate beacons (1 through 7 for Station

No. 1, and 8 through 15 for Station No. 2) as dictated by the gating signal from the timing chassis. The driver efficiency must be 60% or greater and protection must be provided to prevent damage in case of a shorted or open output.

#### 4.1.6 Ship-to-Shore Radio

One ship-to-shore radio with a minimum power input to the last stage of 200 watts will be supplied. At least five crystal-controlled frequencies are to be available by front panel switch. These are to be 2182 kc, 2638 kc and 2738 kc, Nassau Marine, and Miami Marine. Accessory equipment such as a microphone, antenna (whip type), antenna lead-in, and antenna matching network is to be included.

#### 4.1.7 Transmitter (required at Station No. 1 only)

One data transmitter with a minimum power input to the last stage of 200 watts will be provided. Crystal control of the single transmitted frequency is required. Transmitted frequency will be between 2000 and 5000 kc and will be specified later. No microphone is required.

An input plug containing connections for modulation and keying of the transmitter is to be provided. The input level is to be 1-volt RMS for 100% modulation. A locking panel control is to be provided for the modulator input voltage adjust. Accessory equipment such as the antenna (whip type, separate from previous antennas), antenna lead-in, and antenna matching network is to be included.

#### 4.1.8 Receiver

A superheterodyne receiver with crystal control and automatic volume control (AVC) is to be provided. The receiver at Station No. 1 will be set to receive WWV (2500 kc) and the receiver at Station No. 2 will be set to receive the data transmitter signal. The receiver is to have a speaker with a separate level control. An output jack with its own independent level control is to be provided for use with external equipment. The output level at this jack is to be at least 1-volt RMS at 100% modulation and full gain. Accessory equipment such as the antenna (whip type, separate from previous antennas) and antenna lead-in is to be included.

#### 4.1.9 Test Equipment

A list of test equipment to be provided is described on the following page.

4.1.9.1 One oscilloscope with a response of at least dc to 10 mc with wide band d-c dual trace and high sensitivity differential d-c plug-in units.

4.1.9.2 One multimeter of at least 20,000 ohms per volt on dc and 1000 ohms per volt on ac.

4.1.9.3 One oscillator capable of being tuned from at least 20 cps to 5 mc with a minimum of 1-volt RMS output into a 600-ohm load.

4.1.9.4 One universal counter with at least five decade counters capable of counting at a 5-mc rate (minimum) and capable of measuring either events per unit time or time between events. An oven-stabilized crystal control oscillator is to be provided as the internal standard.

4.1.9.5 One vacuum tube voltmeter (VTVM) capable of measuring to at least 3 mv full scale from 20 cps to 5 mc, with a 5% or better accuracy and an input impedance of 10 megohms or more at 10 kc.

4.1.9.6 One SWR meter capable of operation in the 2- to 5-mc region.

#### 4.1.10 Miscellaneous Equipment and Facilities

4.1.10.1 Ceiling fluorescent lights with a minimum wattage of 320 watts per room, a spotlight over each door and a bathroom light.

4.1.10.2 A minimum of 24 duplex 110-volt outlets distributed in the equipment room, 8 duplex 110-volt outlets distributed in the diesel generator room and one duplex outlet in the bathroom.

4.1.10.3 A circuit breaker panel is to be provided with a 15-amp breaker for each group of four duplex outlets. Two separate circuits are to be provided for the lights. The division of the load will be approximately equal among all three phases.

4.1.10.4 A standby 120-amp-hr, 24-volt battery with trickle charge and a 110-volt a-c dynamotor are to be provided for ship-to-shore radio operation.

4.1.10.5 Emergency lights (one 25-watt light in the equipment room and one 25-watt light in the diesel generator room) operating from the 24-volt battery are to come on automatically if the 110-volt power fails.

4.1.10.6 One desk.

4.1.10.7 Two chairs.

CONFIDENTIAL

4.1.10.8 Two cots.

4.1.10.9 One dual 1000-watt hot plate.

4.1.10.10 One 8-cu ft refrigerator.

#### 4.2 Deep Stations

##### 4.2.1 Projector

The projector is to consist of two elements separated by 1.6 ft (center to center). The projector is to have an efficiency of at least 30% at its maximum efficiency point, which is to be between 1800 and 2400 cps. The efficiency is to be at least 15% at 1800 and 2400 cps. The two sections must be capable of delivering 1000 acoustic watts to the water at the maximum efficiency frequency for a period of 15 sec or more. Operation is required in an ambient pressure of 3000 psi and the projector must be equalized for this pressure. Gas pressure equalization is not acceptable. The output of the projector must be within 1 db of the sea level values in the frequency range of 1.8 to 2.4 kc.

##### 4.2.2 Matching Network

A matching network consisting of a matching transformer and necessary inductive and capacitive components is required. The matching network is to be double tuned at frequencies of approximately 1.9 and 2.3 kc, such that the acoustic output of the projector is capable of delivering at least 500 watts and is within 3 db of flat response in the frequency bands of 1.8 to 2.0 kc and 2.2 to 2.4 kc when driven through the characteristic cable impedance with 3 kw available at the transformer.

The matching elements must be capable of handling 3 kw of pulsed electrical power in the frequency band of 1.8 to 2.4 kc without damage when the duty cycle is 10% and the maximum on time is one minute. The matching elements must operate at a pressure of 3000 psi and the double tuned frequencies at 3000 psi must not change more than  $\pm 50$  cps from the sea level values.

##### 4.2.3 Protective Cage

A protective cage which houses the projector and matching elements is to be included. The matching elements are to be stored in a pressure-equalized, oil-filled container called the matching can. Connections to the projector, matching elements and cable are to be made with molded polyethylene harnesses and plugs. The cage is to be made such that it provides for convenient connection to the anchor and cable termination. The center of the lower section of the projector is to be 1.6 ft from the bottom of the cage.

CONFIDENTIAL  
ER 12316

#### 4.2.4 Anchor and Base

A base shall be provided that is approximately 8 ft in diameter and 500 lb in weight. The base is to serve as an anchor as well as a platform to minimize sinking and tilting of the projector.

#### 4.2.5 Implantment Location

The 15 beacons are to be implanted in the following positions within 1000 yd (30" of latitude, 33" of longitude).

<u>Beacon No.</u>	<u>North Latitude</u>	<u>West Longitude</u>
1	24° 47' 30"	76° 31' 30"
2	24° 41' 00"	76° 40' 00"
3	24° 38' 00"	76° 29' 00"
4	24° 30' 30"	76° 10' 00"
5	24° 28' 30"	76° 20' 00"
6	24° 20' 00"	76° 22' 00"
7	24° 21' 30"	76° 12' 00"
8	24° 12' 00"	75° 59' 00"
9	24° 15' 00"	75° 48' 30"
10	24° 02' 00"	76° 01' 45"
11	24° 05' 30"	75° 51' 30"
12	23° 52' 30"	75° 41' 30"
13	23° 54' 30"	75° 31' 30"
14	23° 43' 00"	75° 45' 30"
15	23° 45' 00"	75° 35' 00"

#### 4.2.6 Interconnecting Cable

The beacons are to be connected to shore via deep sea cable. Beacons 1 through 7 are to terminate at Station No. 1 and Beacons 8 through 15 are to terminate at Station No. 2. The cable run is to be made to one beacon and then continue on to a second beacon. In order to accomplish this, two different cable types are required.

The first type consists of a quad cable (called Quad 1) with a low loss and a high loss pair. The high loss pair is to have an attenuation of not more than 8 db at 2.1 kc for an 18-mi run. The low loss pair will be described with the second cable.

CONFIDENTIAL

The second cable type consists of a quad cable (called Quad 2) with two equal pairs. These pairs are connected in parallel and the parallel combination is driven through the low loss pair of Quad 1. The total loss is not to exceed 8 db at 2.1 kc after traversing through 19 mi of Quad 1 and 11 mi of Quad 2.

Each cable is to consist of polyethylene-covered wires capable of receiving 20 kw of 2.1 kc at shore. The deep cable is to have an internal strength member which is capable of supporting the cable weight plus 1000 lb during installation in 6000 ft of water. The outer portion of the cable is to be covered with polyethylene for protection and the cable is to be designed for wet operation. The last one mile of shore cable is to be armored for protection from abrasion. Cable life desired is 10<sup>1</sup>yr and the cable must be capable of being retrieved and relaid at least once during that time. No magnetic shielding is required.

The following eight cable lays are required.

Cable Lay	Far Beacon	Interconnecting Cable Type	*Length (naut mi)	Close Beacon	Interconnecting Cable Type	*Length (naut mi)	Shore End Cable Type	*Length (naut mi)	Station No.
A	1	Quad 2	11.5	2	Quad 2	12.5	Quad 1	1	1
B	3	Quad 2	16	--	--		Quad 2	1	1
C	6	Quad 2	11.5	4	Quad 1	23.5	Quad 1	1	1
D	7	Quad 2	<u>11.5</u>	5	Quad 1	<u>23.5</u>	Quad 1	<u>1</u>	1
Northern end subtotal			50.5			59.5		4	
E	8	Quad 2	11.5	10	Quad 1	25.5	Quad 1	1.5	2
F	9	Quad 2	11.5	11	Quad 1	29	Quad 1	1.5	2
G	12	Quad 2	11.5	14	Quad 1	11	Quad 1	1.5	2
H	13	Quad 2	<u>11.5</u>	15	Quad 1	<u>23.5</u>	Quad 1	<u>1.5</u>	2
Southern end subtotal			46			89		6	
Total			96.5			148.5		10	

\*A total of 15% extra for slack and navigational errors is included in these values.

A cable termination is to be provided that will allow mechanical connection between the strain member and the beacon. All electrical leads of the cable are to terminate in molded polyethylene plugs which mate with connectors on the matching can.

#### 4.2.7 Location Tests

Each beacon is to be located to an absolute accuracy of  $\pm 25$  ft. This is to be accomplished using a hydrophone between 50 to 100 ft of depth on a surface ship. Only the direct path propagation (5 mi or less horizontal range) is to be utilized. The sonar ranges are to be compared with the Decca above water navigation system with a corrected accuracy of at least  $\pm 15$  ft. Runs are to be made at 1-1/2-mi intervals N-S and E-W from the center of the beacon to a maximum of 4-1/2-mi range. The average position is then to be computed by statistical methods.

#### 4.3 Navigation Computer

The navigation computer must be separated into parts small enough to pass through a submarine hatch (24-in. diameter opening) and be easily carried by one man (less than 50 lb weight). The overall power dissipation is to be less than 750 watts. A list of parts of the submarine navigation computer is described below.

##### 4.3.1 Receiver

The receiver is to consist of a band-pass amplifier with band limits of 1.75 to 2.45 kc. The response is to be uniform within limits of 3 db. The attenuation at frequencies 10% below and 10% above the lower and upper band limits, respectively, is to be at least 40 db. From these points, the response is to fall off at a minimum rate of 36 db per octave. The receiver input impedance is to be at least 10,000 ohms and the input level will be a minimum of 10 mv within the band limits. The receiver inputs will come from a low self-noise hydrophone preamplifier. Automatic gain control (AGC) is required with a minimum dynamic range of 70 db and a maximum output change of 3 db over that range.

The maximum voltage gain with zero AGC voltage is to be at least  $10^5$ . The AGC time constant is to be  $15 \pm 5$  sec on charge, and  $10 \pm 5$  sec on discharge. The amplifier is to be protected against signal overloads and is to have a signal dynamic range of 30 db above the noise.

##### 4.3.2 FM Demodulator

The output of the receiver is to be separated into two channels, 1.75 to 2.05 kc and 2.15 to 2.45 kc. The attenuation of the undesired channel must be at least 40 db. Two outputs, which are automatically switched to either of the two channels, are mixed with a reference signal in such

a manner that the frequency difference is taken. The frequency difference that corresponds to a negative frequency difference is to be filtered out by a 200-cps band-pass filter, and is to be further mixed with a  $200 \pm 5$  cps signal, such that 200 cps is added to the frequency of this signal. Both the original and 200-cps shifted signals are to be added together equally in amplitude and then passed through another 200-cps band-pass filter to reject the unwanted frequencies. The 200-cps band-pass filters are to have a response within 3 db inside the band-pass limits, and a rejection of at least 40 db at frequencies greater than 10% outside the band-pass limits.

The output of each channel is then fed to separate banks of comb filters. Each filter bank is to contain 10 filters spaced  $20 \pm 5$  cps apart at their center frequencies and  $20 \pm 5$  cps wide at the 3-db points within the 200-cps band of interest. The skirt slope of each filter is to be sufficient so that the center frequency of the adjacent filters is down at least 18 db. The filter outputs levels are to be adjusted so that their maximum outputs are within  $\pm 1$  db over the frequency range of interest. The outputs of each comb filter bank are then to be sampled in recurring sequence every 50 ms (5 ms per filter). This signal is to be demodulated with a filter time constant of 2.5 to 5 ms and passed through a threshold detector with a threshold 15 db above the maximum noise output of the AGC amplifier.

#### 4.3.3 FM Reference

Four independent FM reference signals are to be generated. Each of these will be automatically switched to one of four types corresponding to station codes A, B, C or D. Each type will continuously repeat itself every 50 ms upon command from the digital dock.

- A Swept linearly 200 cps in 50 ms in ascending frequency from the reference frequency.
- B Swept linearly 200 cps in 50 ms in descending frequency from the reference frequency plus 200 cps.
- C Swept linearly 200 cps in 50 ms in ascending frequency from the reference frequency plus 400 cps.
- D Swept linearly 200 cps in 50 ms in descending frequency from the reference frequency plus 600 cps. The frequency shall be within  $\pm 5$  cps of the exact values.

Provision shall be made to correct for doppler shift as determined by the dead reckoning computer.

#### 4.3.4 Range Computer

The range computer is to determine the horizontal range of each of the two signals from their respective beacons. The equation to be solved is as follows:

$$R = \sqrt{[t(K_1 + K_2t + K_3t^2 + K_4d_s + K_5d_s^2 + K_6d_B + K_7d_B^2 + K_8d_R + K_9d_R^2)]^2 - [d_R - 2d_B - d_S + 3d_r]^2}$$

where

- R = horizontal range
- t = travel time (time between reference and threshold excession)
- $d_s$  = difference between source depth and reference depth
- $d_B$  = difference between bottom bounce depth and reference depth
- $d_R$  = submarine depth
- $d_r$  = reference depth.

$K_1$ ,  $K_2$  and  $K_3$  are constants depending on velocity depth profile and must be front panel adjustments.  $K_4$  and  $K_5$  are beacon constants.  $K_6$  and  $K_7$  are bottom depth variations which are derived from the dead reckoning computer as a function of angle range to the beacon.  $K_8$  and  $K_9$  are depth correction constants which vary in steps as a function of arrival time.

The values of the above constants will be determined in the accuracy portion of the program.

The travel time is determined by counting the time between a reference time generated by the digital clock and receipt of the first threshold excession in the range gated interval (determined by the dead reckoning computer). The timing and computation is not to add more than  $\pm 5$  ft of equivalent range error.

The position computer is to store the first of the two ranges,  $R_1$  or  $R_2$ , and correct it for ship's motion, as determined by the dead reckoning computer. Upon receipt of the second range, the position is to be computed by solving the following two simultaneous equations.

CONFIDENTIAL

$$(X - X_m)^2 + (Y - Y_m)^2 = R_m^2$$

$$(X - X_n)^2 + (Y - Y_n)^2 = R_n^2$$

where X and Y are the submarine position coordinates

$X_m$  and  $Y_m$  are the mth beacon coordinates

$X_n$  and  $Y_n$  are the nth beacon coordinates

$R_m$  = range to the mth beacon

$R_n$  = range to the nth beacon.

The ambiguity of position is to be removed by comparing with the position determined by the dead reckoning computer.

#### 4.3.5 Dead Reckoning Computer

The purpose of the dead reckoning computer (DRC) is to continuously compute the submarine position and then be periodically corrected by the position computer. In addition, the DRC supplies correction data to the range and position computers.

##### 4.3.5.1 Inputs

The inputs to the dead reckoning computer consist of three wire (60-cycle, 90-volt line to line) synchro data for submarine heading, speed and depth.

##### 4.3.5.2 Computations

The DRC is to take the input information and compute the continuous submarine position with an error of 1 fps or less. Provision must be made to insert initial position and large corrections manually. From this initial position, the DRC is to determine the closest A, B, C and D beacons. In addition, bearing to an accuracy of  $\pm 1^\circ$ , range to an accuracy of  $\pm 2000$  ft, and range rate to an accuracy of  $\pm 5$  fps are to be computed for each of the four types of beacons.

The two closest beacons of the four types are to be selected by the DRC, except when the difference of their relative bearings is within  $\pm 15^\circ$  of either  $180^\circ$  or  $0^\circ$ . In this case, the closest beacon and the third closest beacon are to be chosen. When the choice of the two best beacons is made, the DRC is to automatically switch the FM demodulator, FM

reference, range computer corrections and position computer constants to the corresponding beacon values.

The bottom bounce depth is to be derived by selection of the correct cam on the two beacon bearing servos corresponding to the two beacons chosen for position computation. Range gating information ( $\pm 2000$  ft on each side of the computed range) is to be supplied to the range computer. Range change to each of the two beacons is to be computed for a time of 20 sec after receipt of a threshold excession; the accuracy of this computation is to be  $\pm 10$  ft. This information is to be supplied to the position computer for updating the first range signal. Range rate is also to be supplied to the FM reference to provide doppler correction.

The DRC is to accept position correction signals from the position computer if the correction is less than  $\pm 1000$  ft in each axis. A warning light is to be activated if the sonar position and DRC position differ by more than  $\pm 1000$  ft on either axis for three or more position computations in a row.

#### 4.3.5.3 Outputs

The submarine position, according to the DRC, is to be indicated on rectangular coordinate dials, indicating in digital fashion tens, units, tenths and hundredths of a nautical mile. The hundredths indicator can be part of the tenths column. Another indicator is to be supplied showing degrees, minutes, seconds and tenths of seconds of latitude and longitude. The tenths of seconds can be part of the seconds indicator. A selector switch is to be provided which selects either rectangular or latitude and longitude analog output voltages. These output voltages are to have an accuracy of  $\pm 0.02\%$  of full scale.

Digital latitude and longitude codes are to be available for recording in sequential BCD form.

#### 4.3.6 Digital Clock

A digital clock must be available for the range and position computations. The clock in some cases can be part of existing submarine equipment. If none complying with the following specifications is available, a separate clock with the same specifications is to be supplied with the navigation computer. The required specifications are as follows.

4.3.6.1 Time accuracy: Less than 3-ms drift and setting error in 24 hr.

4.3.6.2 Calibration: Must provide for calibration by WWV every 24 hr.

CONFIDENTIAL

4.3.6.3 Output: Pulses every 50 ms starting on the half minute and pulses every 1/2 minute on the half minute. Timing error is to be  $\pm 1$  ms or less plus clock drift.

4.3.6.4 Standby power: Standby battery power is to be provided to the oscillator and counting circuits automatically in case of failure of the main power.

4.3.6.5 Indication: Digital indication of hours, minutes and seconds based on the 24-hr clock is to be provided in visual form plus a digital code for recording in BCD form.

#### 4.3.7 Accuracy Tests

Upon completion of the location tests, the navigation computer constants are to be determined. These are to be derived from tests with a hydrophone lowered at various depths of 150 to 1500 ft from a surface ship and using an accurate ( $\pm 15$  ft or better corrected accuracy) above-water navigation system. The surface ship is to make runs at 2-mi intervals up and down the range and record position error as a function of range from each beacon and hydrophone depth. The various computer constants are to be computed such that the overall one-sigma accuracy is 50 yd or less.

Initially, an experimental computer (eliminating all automatic functions except range and position computation) is to be used. After this, a prototype computer is to be built and tested to show overall system performance.

#### 4.4 Computer Analyzer

A computer analyzer is to be built to permit testing and calibration of the finalized navigation computers without requiring on-site tests. The analyzer shall provide the following:

- 4.4.1 Simulated Submarine Heading 0 to 360°
- 4.4.2 Simulated Submarine Velocity 0 to 50 kn
- 4.4.3 Simulated Submarine Depth 0 to 2000 ft
- 4.4.4 Simulated Sonar Signals

Four simulated sonar signals of A, B, C and D coding, and each with a selectable time delay in 1-ms steps from 0 to 20 sec accurate to  $\pm 1$  ms, will be provided. The simulated sonar pulses are to be  $50 \pm 2.5$  ms long and have an instantaneous frequency within  $\pm 5$  cps of the exact value

during the pulse period. The output level of each signal is to be variable from 0.1 to 0.001 volt by a stepped attenuator with 2-db steps. The last position of the attenuator is to provide 0 volt ( $-\infty$  db) of the signal.

#### 4.4.5 White Noise Signal

A white noise signal in the band of 1 to 3 kc is to be added to the output signals and is to be variable in 2-db steps from 0.1 to 0.001 volt RMS. The last step on the attenuator is to provide 0 volt RMS.

#### 4.4.6 Simulated Doppler

This is to be accomplished by four separate controls (one for each coding) that can be set from 50 to -50 kn. These controls are to shift the center frequency of the coded pulse by an amount proportional to the doppler setting (0.64 cps/kc/kn) within  $\pm 5$  cps.

#### 4.4.7 Analyzer Time Reference

The analyzer time reference is to come from the 50-ms and the 1/2-sec repetition rate pulses generated by the navigation computer digital clock.

### 4.5 Navigation Recorders

Two types of recorders can be used with the system. One is an analog type X-Y plotter and the other is a tape recorder. Both recorders must be built in sections that can pass through a 24-in. diameter opening and weigh less than 50 lb each.

#### 4.5.1 Analog Recorder

The analog recorder is to take d-c signals for the X and Y coordinates and is to plot position as a function of time. The characteristics of this recorder are to be as follows:

- Power input: 115 volts  $\pm 10\%$ , 60  $\pm 5$  cps, 250 watts maximum.
- Sensitivity: 1 volt full scale both axes.
- Zero adjust: Must be capable of moving the zero point  $\pm 0.1$  volt of the center of the chart. The potentiometer or switches to accomplish this shall be capable of being easily reset to within  $\pm 0.2$  mv by means of a dial or other form of indicator.

CONFIDENTIAL

- Paper size: The paper size shall be at least 16 x 16 in.
- Accuracy: At least  $\pm 0.1\%$  of full scale including hysteresis.
- Writing speed: The recorder must be capable of writing at the rate of 0.2 in./min with the stated accuracy.

#### 4.5.2 Tape Recorder

A tape recorder is to be used for the permanent recording of submarine position versus time. The characteristics of this recorder are as follows:

- Power input: 115 volts  $\pm 10\%$ , 60  $\pm 5$  cps. 500 watts maximum.
- Speed: 1-7/8 in./sec.
- Input: Twelve digits of BCD coded position data, five digits of BCD coded time data and a voice channel.
- No. of channels: Two, one for data and one for voice.
- Format: A word start code, consisting of three ones, is to be recorded in serial form followed by 20 time bits (5 digits of BCD) in serial form in descending order followed by 48 bits (12 digits of BCD) of position data in serial descending order, followed by a longitudinal parity bit and ending with a word end code (two ones).
- Rate of recording: The tape recorder is to run continuously and is to record position and time information every 5 sec with at least a 2-sec gap between records.
- Voice input: The voice input is to be by means of a self-contained press-to-talk microphone.

#### 4.6 Handbooks

Complete operational handbooks including schematics and simplified block diagrams are to be furnished with one copy located in each of the two stations.

#### 4.7 Spares

Two complete spares are to be furnished for equipment included at each station. One set of spares is to be located at each of the two stations.

#### 5.0 GOVERNMENT FURNISHED EQUIPMENT

The following items are to be GFE:

5.1 One site on Eleuthera Island suitable for Station No. 1, at or near Bamboo Point, with cable access rights from the site to Exuma Sound and access rights from the site to the nearest main road.

5.2 One site on Great Exuma Island suitable for Station No. 2, at or near Stevenson, with cable access rights from the site to Exuma Sound and access rights from the site to the nearest main road.

5.3 One set of shipboard Decca navigation equipment including two copies of navigation charts, plus spares and one operator.

5.4 One radio frequency assignment between 2 and 5 mc for transmission of timing signals.

5.5 One analyzed bottom core sample, at least 3 ft deep, from the approximate center of each of the four beacon groupings. Core samples are to be analyzed for composition and load bearing characteristics.

APPENDIX D

SUBMARINE POSITION LOCATION  
THROUGH RANGE MEASUREMENTS FROM TWO OR THREE  
BEACONS; MAXIMUM ERROR ESTIMATION

ABSTRACT

The location of a submarine's position by means of range measurements from two or three beacons is an important part of the Exuma Sound project. The study of the effect of errors on various measurements is necessary in order to establish a basis for equipment design choice and to establish a priority for areas of design improvement. A mathematical model, using the Monte Carlo technique for the submarine location problem, is developed in this report, and its simulation on a digital computer (IBM 7090 or IBM 1620) is described. Application of the model to other problems is discussed.

CONTENTS

	Page
Summary . . . . .	D-4
I. Exact Solution of the Three-Beacon Problem . . . . .	D-7
II. Insertion of a Set of Errors in the Three-Beacon Problem . . . . .	D-17
III. Statement of the Three Two-Beacon Problems . . . . .	D-19
IV. Solution of the Basic Trigonometric Problem . . . . .	D-25
V. Solution of Each Two-Beacon Problem with Errors Introduced from the Three-Beacon Problem. . . . .	D-27
VI. Solution of the Problem on a Digital Computer . . . . .	D-35
VII. Statistical Calculations and Computer Program Output . . . . .	D-37
VIII. Use of the Results . . . . .	D-39
IX. Other Applications and Related Problems . . . . .	D-41
X. Random Selection of a Value from a Standard Normal Distribution . . . . .	D-43

CONFIDENTIAL

SUMMARY

This appendix is a detailed geometric and trigonometric analysis of the problem of locating a submarine's position by use of range measurements from two or three known beacon positions. Ping emission times and ping arrival times are used as well as the speed of sound in water and the submarine's speed. The problem admits error increments in the measurements and studies the effects of these errors on the accuracy of the resulting estimation of the submarine's position at the time the third ping arrives. This study is necessary in order to determine the best design for equipment used in locating a submarine's position.

When three beacons are used, the submarine is assumed to move in the direction away from the beacon whose ping is the last one to reach the initial position of the submarine. This direction is considered the one in which maximum errors will occur. The exact solution is obtained on the assumption of exact data and is used as a reference for approximate solutions in which errors of measurement are introduced.

The three-beacon problem is then separated into three two-beacon problems. From each of these, an estimate of the final position of the submarine is made after errors are introduced. One of these problems is the basic two-beacon problem.

A discussion of the requirements for solving this problem on a digital computer is included herein, as well as a statement of the statistical analysis to be made on computer results. This analysis can be made partially by a computer program.

The problem is analyzed to the degree necessary to simulate it on a digital computer of the IBM 7090 class with little explanation to the programmer. This simulation must be done if the full benefits of the analysis are to be obtained. Statistical analysis of the data generated by random sampling is included.

The problem so simulated can be used for purposes such as:

- (1) To obtain an estimate of the error in estimating the position of a submarine under a given set of conditions.
- (2) To determine the effect on the error estimate of a change in a given error term when the others are held constant.

CONFIDENTIAL

ER 12316

- (3) To determine what reduction of error in one variable produces a reduction in the error estimate comparable to a given reduction in the error of another variable. This will enable one to determine what variables are of major importance in the problem and to rate the corresponding system components according to sensitivity in producing the changes in error estimation.
- (4) To compare the results with a statistical analytical model based on certain simplifying assumptions, in order to determine the area of usefulness of that model, since the analytical model is easier to use.
- (5) To study problems which are related in nature but not in appearance, such as location of an enemy radiator by means of bearing calculations based on electromagnetic radiations.

Other applications of the basic ideas underlying this problem are discussed, and consideration is given to the necessity of changing the assumption that an error is normally distributed when experimental data become available for a particular variable.

## I. EXACT SOLUTION OF THE THREE-BEACON PROBLEM

### A. DESCRIPTION OF THE PROBLEM

In the exact problem, the positions,  $B_1$ ,  $B_2$  and  $B_3$ , of the three beacons and the initial position,  $S$ , of the submarine are given. Also given are the ping emission times,  $t_1$ ,  $t_2$  and  $t_3$ , at each beacon and the speed,  $V$ , of sound propagation in water. These data enable one to determine the order of ping arrival times at the submarine. The first arrival time is labeled  $T_1$ . The beacons and their emission times are relabeled  $B_1$ ,  $B_j$ ,  $B_k$  and  $t_1$ ,  $t_j$ ,  $t_k$  according to this order and these labels are used thereafter. With the speed,  $v$ , of the submarine given, and the direction of motion along the line through  $B_k$  and  $S$  away from  $B_k$ , the time  $T_3$ , when the ping from  $B_k$  overtakes the submarine, is easily calculated. This result is used to calculate  $T_2$ . The positions  $S_k$  and  $S_j$  corresponding to these times are also calculated. Details of the exact solution are discussed in the following sections.

### B. INITIAL INFORMATION

At the start of the problem, the following information and conditions are assumed.

- (1) A rectangular coordinate system  $(x, y)$ .
- (2) The beacons  $B_1$ ,  $B_2$  and  $B_3$ , with coordinates  $(x_1, y_1)$ ,  $(x_2, y_2)$  and  $(x_3, y_3)$ , respectively.
- (3) The beacon ping emission times  $t_1$ ,  $t_2$  and  $t_3$ , where  $0 \leq t_1 \leq t_2 \leq t_3$ .
- (4) The submarine position,  $S$ , with coordinates  $(x_S, y_S)$ .
- (5) The beacons and the ping times are paired, but the ping arrival times at  $S$  determine the use of the subscripts  $i$ ,  $j$ ,  $k$ . It may happen that two or more pings reach  $S$  at the same time, and these cases will be treated separately. For the present, however, the arrival times are assumed to be different.

- (6) The pings from  $B_i$ ,  $B_j$  and  $B_k$  reach S in that order.
- (7) The first ping reaches S at time  $T_1$ , which is to be calculated.
- (8) The submarine is moving from S, along the line through  $B_k$  and S, away from  $B_k$ , with a speed  $v$ ; the submarine is at S at time  $T_1$ .  $T_1$  is the time at which the problem is considered to start.
- (9) Sound is propagated through sea water according to a speed function,  $V$ , which may be a constant, a curve in two sections or a function given by a formula in two parts. If not a constant,  $V$  is expressed by curve or function as a value versus distance.
- (10) The pings from  $B_j$  and  $B_k$  reach the submarine at positions  $S_j$  and  $S_k$ , respectively, at the corresponding times  $T_2$ ,  $T_3$ .
- (11) The following symbols represent the distance each ping travels from its beacon to the submarine:

$$\begin{aligned} R_i &= \overline{B_i S} \\ R_j &= \overline{B_j S_j} \\ R_k &= \overline{B_k S_k} \end{aligned}$$

### C. ASSIGNMENT OF SUBSCRIPTS TO BEACONS

The ping arrival times at S are calculated by the formula  $T = t_m + \frac{\overline{B_m S}}{V}$ . The subscripts  $i$ ,  $j$  and  $k$  are assigned so that

$$T_1 = t_1 + \frac{\overline{B_i S}}{V} \leq t_j + \frac{\overline{B_j S}}{V} \leq t_k + \frac{\overline{B_k S}}{V}. \quad (D-1)$$

The possibility of two or more arrival times being equal is not ruled out, but it is implicitly assumed that they are all unequal.

D. PING ARRIVAL TIMES  $T_2$  AND  $T_3$  AT POINTS  $S_j$ ,  $S_k$

Referring to Item 10 in Section A, the submarine reaches position  $S_j$  at time  $T_2$ , which is the time the ping from  $B_j$  overtakes the submarine; the symbols  $S_k$ ,  $T_3$  and  $B_k$  are used similarly.

$$T_2 = t_j + \frac{\overline{B_j S_j}}{V} \quad (D-2)$$

$$T_3 = t_k + \frac{\overline{B_k S_k}}{V} \quad (D-3)$$

The main part of the problem is to find  $S_j$ ,  $S_k$ ,  $T_2$  and  $T_3$ .

E. FORMULAS FOR  $T_3$  AND THE  $S_k$  COORDINATES

The ping from  $B_k$  starts at time  $t_k$  and overtakes the moving submarine at the point  $S_k$  at time  $T_3$ . The submarine started to move from position  $S$  at time  $T_1$ . In the distance relation,

$$\overline{B_k S_k} = \overline{B_k S} + \overline{S S_k} \quad (D-4)$$

the distance  $\overline{B_k S}$  is known, and

$$\overline{B_k S_k} = (T_3 - t_k) V \quad (D-5)$$

$$\overline{S S_k} = (T_3 - T_1) v \quad (D-6)$$

$$\text{Therefore, } T_3 = \frac{\overline{B_k S} + t_k V - T_1 v}{V - v} \quad (D-7)$$

Let  $\alpha_k$  be defined as in Fig. D-1; then the coordinates of  $S_k$  are

$$\begin{aligned} x_{S_k} &= x_k - (T_3 - t_k) V \cos \alpha_k \\ y_{S_k} &= y_k - (T_3 - t_k) V \sin \alpha_k \end{aligned} \quad (D-8)$$

The value of  $T_3$  will be used to determine the proper value of  $T_2$ . In determining  $T_2$ , the relative positions of  $B_i$  and  $B_k$  do not enter the calculations.

The condition  $T_1 \leq T_3$  must be satisfied. If  $T_3 < T_1$ , there is an error either in the calculations or in the input. If  $T_1 = T_3$ , then points  $S$  and  $S_k$  are the same point, and this implies that  $T_1 = T_2 = T_3$  and  $S$ ,  $S_j$  and  $S_k$  are the same point (see the following section).

#### F. FORMULAS FOR $T_2$ AND THE $S_j$ COORDINATES

Figure D-1 illustrates one possible configuration of  $B_i$ ,  $B_j$ ,  $B_k$  and  $S$ , and is used for the definition of the angles  $\alpha_i$ ,  $\alpha_j$ ,  $\alpha_k$ , and  $\alpha$ . The line marked (x) passing through  $S$  is parallel to the x-axis of the given (x,y) coordinate system. A different coordinate system would require adding the same constant value to each angle and would not change the resulting formulas.

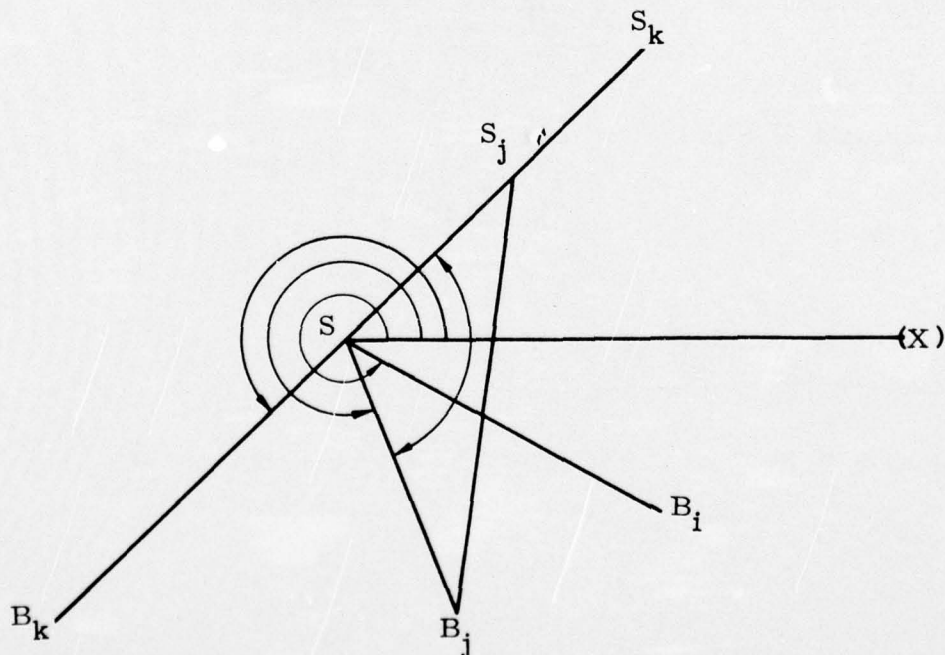

Fig. D-1. Illustration of the Three-Beacon Problem

There are at least 24 different combinations of ranges of values of  $\alpha_i$  and  $\alpha_j$ , corresponding to a fixed value of  $\alpha_k$ ,  $\pi < \alpha_k < \frac{3\pi}{2}$ , that could conceivably result in different formulas for  $\alpha$  and  $\overline{SS}_j$ . These were all examined in detail with the following results.

The possible values of  $\alpha$  in terms of  $\alpha_j$ ,  $\alpha_k$ ,  $\pi$  are

$$\alpha = \begin{cases} (\alpha_k - \alpha_j) + \pi \\ (\alpha_k - \alpha_j) - \pi \\ -(\alpha_k - \alpha_j) + \pi \end{cases} \quad (D-9)$$

In each case,

$$\cos \alpha = -\cos(\alpha_k - \alpha_j) \quad (D-10)$$

It is assumed in this report that  $B_k$  is in the third quadrant, relative to S as the origin of a coordinate system parallel to the (x,y) system. Under this assumption,  $\alpha_k$  is determined by the formula

$$\alpha_k = \pi + \arctan \left( \frac{y_k - y_S}{x_k - x_S} \right) \quad (D-11)$$

where the arctangent function is limited in value between 0 and  $\pi/2$ .

The angle  $\alpha_j$  is determined by use of the following definition of  $\alpha_{jS}$  and Table D-1. The table also gives the formulas for  $\cos \alpha$  in terms of  $\alpha_k$  and  $\alpha_{jS}$ ,

$$\alpha_{jS} = \arctan \left( \frac{y_j - y_S}{x_j - x_S} \right) \quad (D-12)$$

where the arctangent function here is restricted to values between  $-\pi/2$  and  $+\pi/2$ , inclusive.

TABLE D-1

The Angle  $\alpha_j$  as a Function of  $\alpha_{jS}$  and the  
Quadrant of  $\alpha_j$ , and the Formula for  $\cos \alpha$

$y_j - y_S$	$x_j - x_S$	Quadrant	$\alpha_j$	$\cos \alpha$
+	+	I	$\alpha_{jS}$	$-\cos(\alpha_k - \alpha_{jS})$
+	-	II	$\pi + \alpha_{jS}$	$+\cos(\alpha_k - \alpha_{jS})$
-	-	III	$\pi + \alpha_{jS}$	$+\cos(\alpha_k - \alpha_{jS})$
-	+	IV	$\alpha_{jS}$	$-\cos(\alpha_k - \alpha_{jS})$

$\cos \alpha$  may be written in the general form

$$\cos \alpha = -k \cos(\alpha_k - \alpha_{jS}) \quad (D-10a)$$

where

$$k = \begin{cases} +1 & \text{if } x_j - x_S > 0 \\ -1 & \text{if } x_j - x_S < 0 \end{cases} \quad (D-10b)$$

The law of cosines in all cases can be expressed in the form

$$(\overline{B_j S_j})^2 = (\overline{B_j S})^2 + (\overline{SS_j})^2 - 2(\overline{B_j S}) \cdot (\overline{SS_j}) \cos \alpha \quad (D-13)$$

where  $\cos \alpha$  is given by Eq (D-10) or Table D-1.

Previous expressions give

$$\overline{B_j S_j} = (T_2 - t_j) V \quad (D-2a)$$

$$\overline{SS_j} = (T_2 - T_1) v \quad (D-6a)$$

and

$$\overline{B_j S} = \sqrt{(x_S - x_j)^2 + (y_S - y_j)^2} \quad (D-14)$$

Thus, the law of cosines becomes

$$(T_2 - t_j)^2 V^2 = (\overline{B_j S})^2 + (T_2 - T_1)^2 v^2 - 2(\overline{B_j S})(T_2 - T_1)v \cos \alpha \quad (D-15)$$

Equation (D-15) can be written as a quadratic equation in  $T_2$ :

$$\begin{aligned} & \left[ V^2 - v^2 \right] T_2^2 + 2 \left[ T_1 v^2 - t_j V^2 + (\overline{B_j S}) v \cos \alpha \right] T_2 \\ & + \left[ t_j^2 V^2 - (\overline{B_j S})^2 - T_1^2 v^2 - (\overline{B_j S}) T_1 v \cos \alpha \right] = 0 \end{aligned} \quad (D-16)$$

The roots of this equation are:

$$T_2 = \frac{-B \pm \sqrt{B^2 - 4AC}}{2A} \quad (D-17)$$

where

$$\left. \begin{aligned} A &= V^2 - v^2 \\ B &= 2 \left[ T_1 v^2 - t_j V^2 + (\overline{B_j S}) v \cos \alpha \right] \\ C &= t_j^2 V^2 - (\overline{B_j S})^2 - T_1^2 v^2 - 2(\overline{B_j S}) T_1 v \cos \alpha \end{aligned} \right\} \quad (D-18)$$

The discriminant  $B^2 - 4AC$  can be reduced to the form

$$\begin{aligned} B^2 - 4AC &= 4 \left\{ \left[ V^2 - v^2 \sin^2 \alpha \right] (\overline{B_j S})^2 \right. \\ & \quad + 2V^2 v \cos \alpha (T_1 - t_j) (\overline{B_j S}) \\ & \quad \left. + V^2 v^2 (T_1 - t_j)^2 \right\} \end{aligned} \quad (D-19)$$

This is a quadratic expression in  $\overline{B_j S}$  and also in  $T_1 - t_j$ . All terms are positive or zero except the middle term, in which  $T_1 - t_j$  or  $\cos \alpha$  may be negative. Considered as a quadratic expression in  $T_1 - t_j$ , it can be factored as

$$4V^2v^2 \left[ (T_1 - t_j) - r^+ \right] \left[ (T_1 - t_j) - r^- \right] \quad (D-20)$$

where  $r^+$  and  $r^-$  are obtained by use of the quadratic formula and simplified to the following form:

$$r^\pm = - \frac{(\overline{B_j S})}{Vv} \left[ V \cos \alpha \pm i (\sin \alpha) \cdot \sqrt{V^2 - v^2} \right] \quad (D-21)$$

where  $i = \sqrt{-1}$ . Using Eq (D-21) in Eq (D-20) enables one to write

$$B^2 - 4AC = 4V^2v^2 \left\{ \left[ (T_1 - t_j) + \frac{(\overline{B_j S})}{v} \cos \alpha \right]^2 + \frac{(\overline{B_j S})^2}{V^2v^2} (\sin^2 \alpha) \cdot (V^2 - v^2) \right\} \quad (D-22)$$

This indicates that  $B^2 - 4AC \geq 0$  always holds. Therefore, the occurrence of  $B^2 - 4AC < 0$  indicates an error in either the calculations or the input.

There are two values of  $T_2$  to consider. The conditions of the problem indicate that only one of them can be used. It must certainly satisfy the condition  $T_1 \leq T_2 \leq T_3$ . There is an error if neither value of  $T_2$  satisfies this condition. If only one of the values satisfies the condition, it is clearly the  $T_2$  desired. If both satisfy the condition, a choice must be made.

Since  $A > 0$  and  $B^2 - 4AC \geq 0$  always, Table D-2 lists the possible combinations of roots of Eq (D-16) depending on B and C.

TABLE D-2

Relation of Roots of Eq (D-16) to Coefficients  
B and C

<u>Combina- tion</u>	<u>B</u>	<u>C</u>	<u>No. of Positive Roots</u>	<u>No. of Negative Roots</u>	<u>No. of Zero Roots</u>
1	+	+	0	2	0
2	+	-	1	1	0
3	-	+	2	0	0
4	-	-	1	1	0
5	0	-	1	1	0
6	+	0	1	0	1
7	-	0	0	1	1
8	0	0	0	0	2

By Item 3, Section B, all times are positive except possibly  $t_1$ . By this condition, the above table allows a unique choice of  $T_2$  in combinations 2, 4, 5 and 6 (both values of  $T_2$  are possible in combination 3) and an error has occurred in calculations leading to 1, 7 and 8.

Combination 3, where  $B < 0$  and  $C > 0$ , is the only permissible combination that does not give a unique choice for  $T_2$ .

$$\frac{B}{2} = T_1 v^2 - t_j V^2 + (\overline{B_j S}) v \cos \alpha < 0$$

$$T_1 v^2 + (\overline{B_j S}) (\cos \alpha) v - t_j V^2 < 0$$

Consider the quadratic function

$$y = T_1 v^2 + (\overline{B_j S}) (\cos \alpha) v - t_j V^2$$

The values of  $v$  for which  $y < 0$  are of interest here. They are in the interval between the roots of  $y = 0$ , which are

$$\frac{-(\overline{B_j S}) \cos \alpha \pm \sqrt{(\overline{B_j S})^2 \cos^2 \alpha + 4T_1 t_j V^2}}{2T_1}$$

Regardless of the value of  $\cos \alpha$ , one root is negative and the interval for  $v$  is

$$0 \text{ to } \frac{-(\overline{B_j S}) \cos \alpha + \sqrt{(\overline{B_j S})^2 \cos^2 \alpha + 4T_1 t_j V^2}}{2T_1}$$

II. INSERTION OF A SET OF ERRORS IN THE  
THREE-BEACON PROBLEM

The following table includes the error terms used and the quantities to which they are added. The standard deviation is explained later.

TABLE D-3  
Error Terms

<u>Error term</u>	<u>Quantity</u>	<u>Standard Deviation</u>
<u>1. Beacons</u>		
$\Delta x_i$	$\left. \begin{matrix} x_i \\ y_i \end{matrix} \right\} B_i$	$\sigma_{x_i}$
$\Delta y_i$		$\sigma_{y_i}$
$\Delta x_j$	$\left. \begin{matrix} x_j \\ y_j \end{matrix} \right\} B_j$	$\sigma_{x_j}$
$\Delta y_j$		$\sigma_{y_j}$
$\Delta x_k$	$\left. \begin{matrix} x_k \\ y_k \end{matrix} \right\} B_k$	$\sigma_{x_k}$
$\Delta y_k$		$\sigma_{y_k}$
<u>2. Ranges</u>		
$\Delta R_i$	$R_i$	$\sigma_{R_i} = f_i(R_i)$
$\Delta R_j$	$R_j$	$\sigma_{R_j} = f_j(R_j)$
$\Delta R_k$	$R_k$	$\sigma_{R_k} = f_k(R_k)$
<u>3. Submarine movement</u>		
$\Delta x_{SS_j}$	$\left. \begin{matrix} x_{S_j} - x_S \\ y_{S_j} - y_S \end{matrix} \right\} \vec{SS}_j$	$c_j(\overline{SS_j})$
$\Delta y_{SS_j}$		
$\Delta x_{S_j S_k}$	$\left. \begin{matrix} x_{S_k} - x_{S_j} \\ y_{S_k} - y_{S_j} \end{matrix} \right\} \vec{S_j S_k}$	$c_{jk}(\overline{S_j S_k})$
$\Delta y_{S_j S_k}$		

TABLE D-3 (continued)

<u>Error term</u>	<u>Quantity</u>	<u>Standard Deviation</u>
$\Delta x_{SS_k} = \Delta x_{SS_j} + \Delta x_{S_j S_k}$	$x_{Sk} - x_S$	$\left. \begin{array}{l} \\ \\ \end{array} \right\} \vec{SS}_k \quad c_k(\overline{SS}_k)$
$\Delta y_{SS_k} = \Delta y_{SS_j} + \Delta y_{S_j S_k}$	$y_{Sk} - y_S$	

The errors in the vector lengths are equivalent to errors in the direction and speed of the submarine. They are given in the above form for simplicity, since the assumption to be used, probably throughout the study, is that most of the above errors are normally distributed with mean zero and standard deviation as given. The standard deviations for the errors in  $R_i$ ,  $R_j$  and  $R_k$  will be some function of that variable, probably a constant multiple, as in the cases of the vectors  $\vec{SS}_j$  and  $\vec{S_j S_k}$ .

A quantity with an error term added is denoted by the exact symbol with a prime affixed to it. For example,  $B'_i = (x'_i, y'_i) = (x_i + \Delta x_i, y_i + \Delta y_i)$ . This type symbol also applies to points determined by use of approximate points or values (for example,  $S'_j$ ).

In this part of the problem, the point of view is from the submarine, and the values used are the data obtained at the submarine by its equipment. These data are simulated by use of the error terms just listed in accordance with the types of distributions assumed. One value is chosen at random for each term and applied to the exact problem to give a displaced or approximate problem. The resulting coordinates and lengths are used in the two-beacon problems as if they were exact values.

For a detailed discussion of the random selection of errors, see Chapters VI and VII of this appendix.

### III. STATEMENT OF THE THREE TWO-BEACON PROBLEMS

#### A. ILLUSTRATIVE FIGURES

The two-beacon problems are denoted by the symbols  $(B_1, B_j)$ ,  $(B_j, B_k)$  and  $(B_1, B_k)$ . In all problems, the direction of motion is along the line through  $B_k$ , S and away from  $B_k$ . The resulting estimates of  $S_k$  are denoted by  $S_k^{i,j}$ ,  $S_k^{j,k}$  and  $S_k^{i,k}$ , respectively. These problems are illustrated in Figs. D-2, D-3 and D-4.

#### B. THE $(B_1, B_j)$ PROBLEM

In the  $(B_1, B_j)$  problem, the submarine hears the ping from  $B_1$

at time  $T_1 = t_1 + \frac{\overline{B_1 S}}{V}$  and calculates  $\overline{B_1 S}$ . Due to errors in estimating  $B_1$  as if it were at  $B'_1$ , and  $\overline{B_1 S}$  as if it were at  $R'_1 = R_1 + \Delta R_1$ , the submarine is estimated to be at a point  $S'$  somewhere on a circle with radius  $R'_1$  and center  $B'_1$ .

At a later time,  $t_j + \frac{\overline{B_j S_j}}{V}$ , the submarine hears the ping from  $B_j$  and calculates  $\overline{B_j S_j}$ . Again due to errors,  $B_j$  is apparently at  $B'_j$ , the range  $R_j$  is apparently  $R'_j = R_j + \Delta R_j$ , and the submarine is apparently at some point  $S'_j$  on a circle with center at  $B'_j$  and radius  $R'_j$ .

In order to solve for  $S'_j$ , under the assumption that  $B'_1$ ,  $R'_1$ ,  $B'_j$  and  $R'_j$  are correct and known, it is convenient to translate  $B'_1$  to the point  $B''_1$  by use of the vector  $\overrightarrow{SS'_j}$ . This is shown in Fig. D-2. Errors in movement estimation give the point  $B'''_1$ . The triangle  $\Delta B'_j S'_j B'''_1$  contains the measurements and errors involved to this point. The coordinates of these points and the vector components are given below.

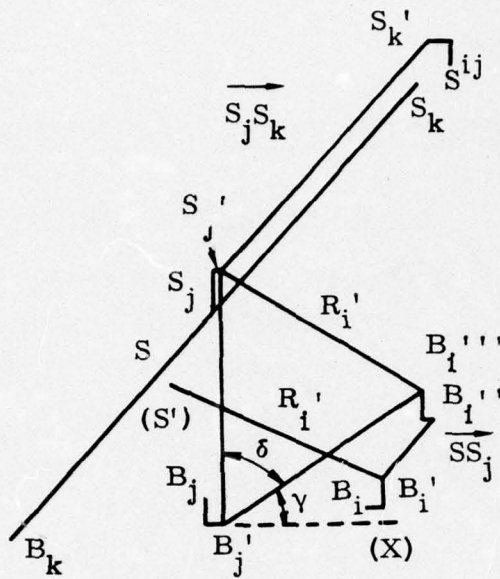

Fig. D-2. The  $(B_i, B_j)$  Problem

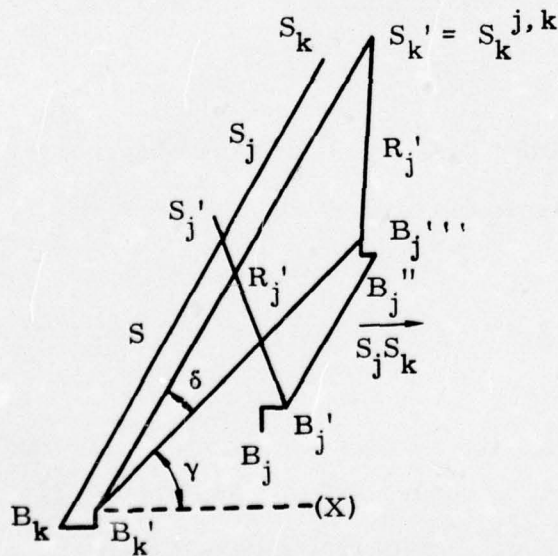

Fig. D-3. The  $(B_j, B_k)$  Problem

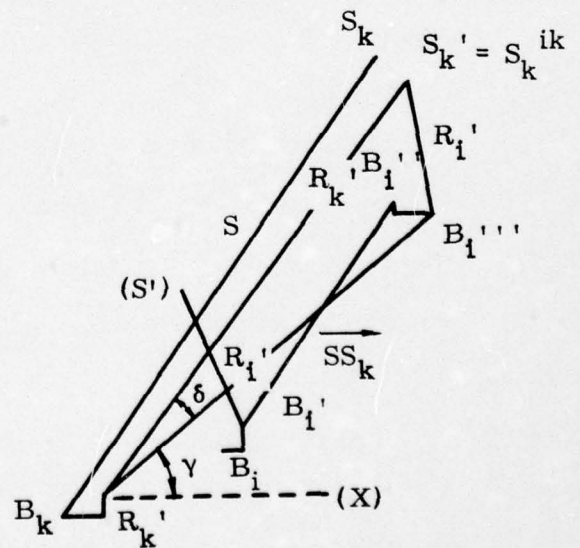

Fig. D-4. The  $(B_i, B_k)$  Problem

AD-A031 531

MARTIN CO BALTIMORE MD ELECTRONIC SYSTEMS AND PRODU--ETC F/G 17/7  
SUBMERGED SUBMARINE NAVIGATION AID STUDY.(U)  
MAR 62

UNCLASSIFIED

ER-12316

NOBSR-85577

NL

3 of 3

AD  
A031531

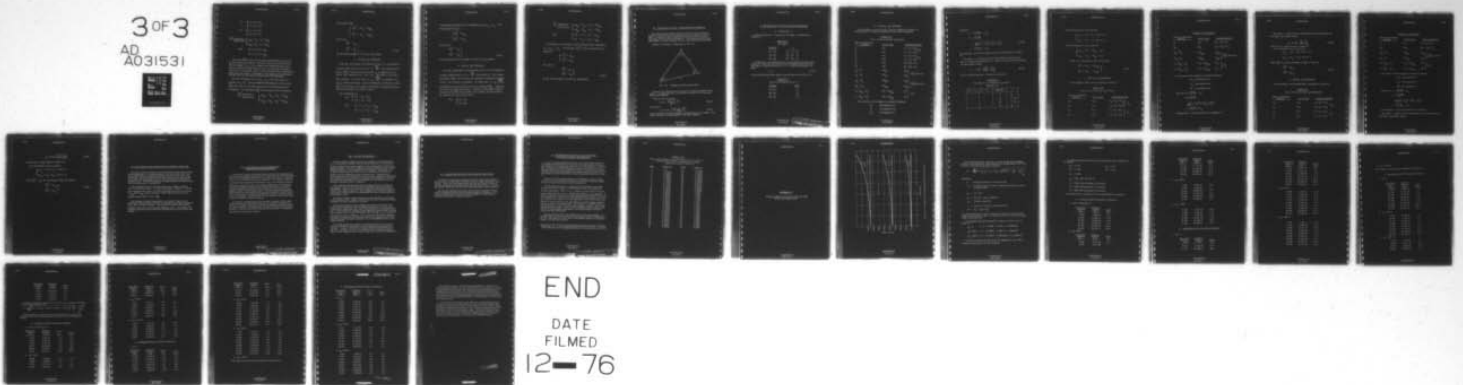

END

DATE  
FILMED

12-76

$$B'_i : \begin{cases} x'_i = x_i + \Delta x_i \\ y'_i = y_i + \Delta y_i \end{cases}$$

$$B'_j : \begin{cases} x'_j = x_j + \Delta x_j \\ y'_j = y_j + \Delta y_j \end{cases}$$

$$\vec{SS}_j \text{ components: (with errors)} \begin{cases} x_{SS_j} = x_{S_j} - x_S + \Delta x_{SS_j} \\ y_{SS_j} = y_{S_j} - y_S + \Delta y_{SS_j} \end{cases}$$

$$B''_i : \begin{aligned} x''_i &= x_i + \Delta x_i + x_{SS_j} \\ y''_i &= y_i + \Delta y_i + y_{SS_j} \end{aligned}$$

The vector  $\vec{SS}_j$  is found from the theoretical solution, since S and  $S_j$  are assumed to be known. Therefore, the side  $B'_j B''_i$  is known and the triangle  $\triangle B'_j S'_j B''_i$  is known as to shape and size, and is fixed in the plane because the points  $B'_j, B''_i$  are fixed in the plane. This fixes  $S'_j$  in the plane, and  $S'_j$  can be found by use of trigonometry (three sides are known). The details of this solution will be deferred until the other two two-beacon problems have been described.

After the coordinates of  $S'_j, (x_{S'_j}, y_{S'_j})$ , have been found, an estimate of  $S_k, S^{i,j}_k$ , can be obtained by translating  $S'_j$  by the vector  $\vec{S_j S_k}$  to the point  $S'_k$  and adding movement error increments to the coordinates. The translation  $\vec{S_j S_k}$  with movement errors is given by:

$$\vec{S_j S_k} \text{ components: (with errors)} \begin{cases} x_{S_j S_k} = x_{S_k} - x_{S_j} + \Delta x_{S_j S_k} \\ y_{S_j S_k} = y_{S_k} - y_{S_j} + \Delta y_{S_j S_k} \end{cases}$$

The result is  $S_k^{i,j}$ :

$$\begin{cases} x_k^{i,j} = x_{S'_j} + x_{S_j S_k} \\ y_k^{i,j} = y_{S'_j} + y_{S_j S_k} \end{cases}$$

The errors,

$$\left. \begin{array}{l} x_k^{i,j} - x_{S_k} \\ y_k^{i,j} - y_{S_k} \end{array} \right\}, \quad (D-23)$$

are the results sought for in the  $(B_i, B_j)$  problem.

### C. THE $(B_j, B_k)$ PROBLEM

In the  $(B_j, B_k)$  problem, as illustrated in Fig. D-3, the submarine receives a ping from  $B_j$  at time  $T_2 = t_j + \frac{\overline{B_j S_j}}{V}$ . This enables calculation of  $\overline{B_j S_j}$ , but due to errors involved,  $S_j$  is apparently at  $S'_j$ ; that is,  $R_j$  is replaced by  $R'_j = R_j + \Delta R_j$ . The point  $S'_j$  is not actually calculated. At a later time,  $T_3 = t_k + \frac{\overline{B_k S_k}}{V}$ , an estimate,  $R'_k$ , of  $R_k$  is obtained similarly. After translating  $B'_j$  to  $B^m_j$  by the vector  $\overrightarrow{S_j S_k}$  with movement errors added, the triangle  $\Delta B'_k S'_k B^m_j$  has three sides and two points,  $B'_k$  and  $B^m_j$ , known.

The coordinates are:

$$B'_k: \begin{cases} x'_k = x_k + \Delta x_k \\ y'_k = y_k + \Delta y_k \end{cases}$$

$$B^m_j: \begin{cases} x^m_j = x_j + \Delta x_j + x_{S_j S_k} \\ y^m_j = y_j + \Delta y_j + y_{S_j S_k} \end{cases}$$

This enables calculation of the coordinates of  $S'_k: x_{S'_k}, y_{S'_k}$ . The estimate  $S_k^{j,k}$  of  $S_k$  is:

$$\begin{cases} x_k^{j,k} = x_{S'_k} \\ y_k^{j,k} = y_{S'_k} \end{cases}$$

The errors,

$$\left. \begin{array}{l} x_k^{j,k} - x_{S_k} \\ y_k^{j,k} - y_{S_k} \end{array} \right\}, \tag{D-24}$$

are the results which are sought for in the  $(B_j, B_k)$  problem.

#### D. THE $(B_1, B_k)$ PROBLEM

In the  $(B_1, B_k)$  problem, as illustrated in Fig. D-4, the submarine receives a ping at time  $T_1 = t_1 + \frac{\overline{B_1 S}}{V}$  from beacon  $B_1$ . This enables calculation of  $\overline{B_1 S}$ . Due to errors, the submarine estimates its position to be  $S'$ , as in the  $(B_1, B_j)$  problem. At a later time,  $T_3 = t_k + \frac{\overline{B_k S_k}}{V}$ , the submarine hears the ping from  $B_k$  and calculates  $\overline{B_k S_k}$ . Again due to errors,  $R_k$  is estimated as  $R'_k$ . After  $B'_1$  is translated to  $B^m_1$  by the exact vector  $\overrightarrow{SS_k}$  with movement errors added, the three sides of the triangle  $\Delta B'_k S'_k B^m_1$  are known.

$$B'_k: \begin{cases} x_k + \Delta x_k \\ y_k + \Delta y_k \end{cases}$$

$$\begin{array}{l}
 \overrightarrow{SS_k} \text{ components:} \\
 \text{(with errors)} \\
 \\
 B_i^m:
 \end{array}
 \left\{ \begin{array}{l}
 x_{SS_k} = x_{S_k} - x_S + \Delta x_{SS_k} \\
 y_{SS_k} = y_{S_k} - y_S + \Delta y_{SS_k} \\
 \\
 x_i^m = x_i + \Delta x_i + x_{SS_k} \\
 y_i^m = y_i + \Delta y_i + y_{SS_k}
 \end{array} \right.$$

The solution of the triangle  $\Delta B'_k S'_k B_i^m$  gives the coordinates of  $S'_k: x_{S'_k}, y_{S'_k}$ . The estimate,  $S_k^{i,k}$ , of  $S_k$  is the same as  $S'_k$ . Therefore

$$\left\{ \begin{array}{l}
 x_k^{i,k} = x_{S'_k} \\
 y_k^{i,k} = y_{S'_k}
 \end{array} \right.$$

The errors,

$$\left. \begin{array}{l}
 x_k^{i,k} - x_{S_k} \\
 y_k^{i,k} - y_{S_k}
 \end{array} \right\}, \quad (D-25)$$

are the results sought for in the  $(B_i, B_k)$  problem.

#### IV. SOLUTION OF BASIC TRIGONOMETRIC PROBLEM

The trigonometric problem involved in each of the two-beacon problems is the solution of a triangle, given the lengths of the three sides. A solution to this problem is given here in a form easily applicable to the two-beacon problems. This solution is used in the next chapter to obtain formulas for use in any three-beacon problem.

Consider the triangle  $\triangle DMN$  given in Fig. D-5.

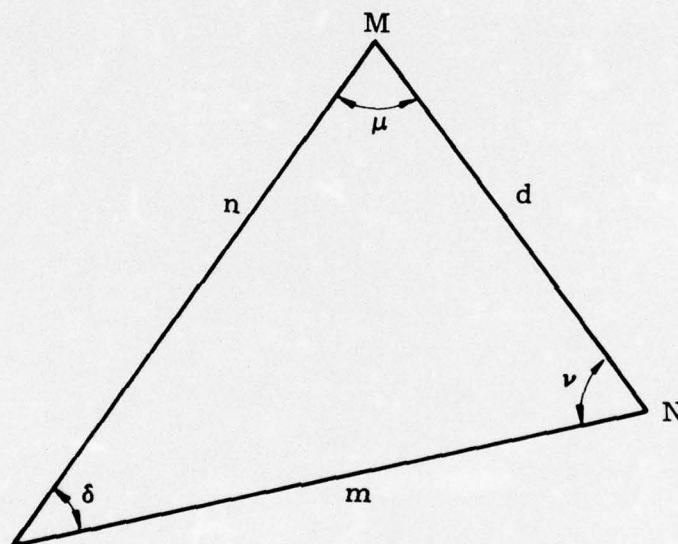

Fig. D-5. Triangle with Three Sides Given

The part of  $\triangle DMN$  that will be useful in the beacon problem is the angle  $\delta$ . An expression for  $\delta$  is all that is needed, so it is the only expression obtained.

From the law of cosines,

$$\cos \delta = \frac{m^2 + n^2 - d^2}{2mn} \quad (D-26)$$

from which

$$\delta = \arccos \left[ \frac{m^2 + n^2 - d^2}{2mn} \right] \quad (D-27)$$

In this formula, as in the triangle, the restriction  $0 < \delta < \pi$  holds. The angle  $\delta$  is defined unambiguously by the above formula.

V. SOLUTIONS OF THE TWO-BEACON PROBLEMS

A. THE ANGLE  $\gamma$

In the three two-beacon problems, the angle  $\gamma$  is defined as in Table D-4.

TABLE D-4  
The Angle  $\gamma$

<u>Problem</u>	<u><math>\gamma</math></u>
$(B_i, B_j)$	$\angle B_i''' B_j' (x)$
$(B_j, B_k)$	$\angle B_j''' B_k' (x)$
$(B_i, B_k)$	$\angle B_i''' B_k' (x)$

In Table D-4, the symbol  $(x)$  refers to any point to the right of the vertex of  $\gamma$  and on the line through that vertex parallel to the x-axis. The angle  $\gamma$  is defined so that  $0 \leq \gamma < 2\pi$ . With this definition, the angle

$$\delta + \gamma \tag{D-28}$$

is used to find a particular point in each problem (see Table D-5).

TABLE D-5  
Point to be Found by Use of  $\delta + \gamma$

<u>Problem</u>	<u>Point</u>
$(B_i, B_j)$	$S'_j$
$(B_j, B_k)$	$S'_k$
$(B_i, B_k)$	$S'_k$

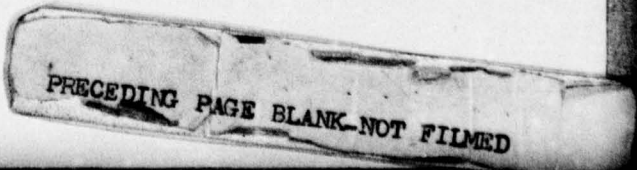

B. THE  $(B_i, B_j)$  PROBLEM

In this problem, the error terms used are displayed in Table D-6 with the exact or calculated quantities to which they are applied.

TABLE D-6  
Error Terms in the  $(B_i, B_j)$  Problem

<u>Exact or Calculated Quantity</u>	<u>Error Term</u>	<u>Resulting Quantity</u>
$x_i$	$\Delta x_i$	$\left. \begin{aligned} x'_i &= x_i + \Delta x_i \\ y'_i &= y_i + \Delta y_i \end{aligned} \right\} B'_i$
$y_i$	$\Delta y_i$	
$x_j$	$\Delta x_j$	$\left. \begin{aligned} x'_j &= x_j + \Delta x_j \\ y'_j &= y_j + \Delta y_j \end{aligned} \right\} B'_j$
$y_j$	$\Delta y_j$	
$R_i$	$\Delta R_i$	$R_i + \Delta R_i = R'_i$
$R_j$	$\Delta R_j$	$R_j + \Delta R_j = R'_j$
$x_{S_j} - x_S$	$\Delta x_{SS_j}$	$\left. \begin{aligned} x_{SS_j} \\ y_{SS_j} \end{aligned} \right\} \rightarrow SS_j \text{ with error}$
$y_{S_j} - y_S$	$\Delta y_{SS_j}$	
$x_{S_k} - x_{S_j}$	$\Delta x_{S_j S_k}$	$\left. \begin{aligned} x_{S_j S_k} \\ y_{S_j S_k} \end{aligned} \right\} \rightarrow S_j S_k \text{ with error}$
$y_{S_k} - y_{S_j}$	$\Delta y_{S_j S_k}$	
$x_i + (x_{S_k} - x_{S_j})$	$\Delta x_i + \Delta x_{S_j S_k}$	$\left. \begin{aligned} x''_i \\ y''_i \end{aligned} \right\} B''_i$
$y_i + (y_{S_k} - y_{S_j})$	$\Delta y_i + \Delta y_{S_j S_k}$	

The vertices of the triangles correspond as follows:

- $B'_j$  corresponds to D
- $S'_j$  corresponds to M
- $B''_i$  corresponds to N

Therefore,

$$\begin{aligned}
 d &= \overline{S'_j B''_i} = R'_i \\
 m &= \overline{B'_j B''_i} \\
 &= \sqrt{(x''_i - x'_j)^2 + (y''_i - y'_j)^2} \\
 n &= \overline{B'_j S'_j} = R'_j
 \end{aligned}
 \tag{D-29}$$

Consequently,  $\delta$  can be calculated from the formula given in Chapter IV.

The angle  $\gamma = \angle B''_i B'_j (x)$  can be determined in the same way that  $\alpha_j$  was determined (Table D-1). Table D-7 is used for this purpose, with the auxiliary angle

$$\gamma_p = \arctan \left( \frac{y''_i - y'_j}{x''_i - x'_j} \right)
 \tag{D-30}$$

which is limited between  $-\pi/2$  and  $\pi/2$ , inclusive.

TABLE D-7

The Angle  $\gamma$  as a Function of  $\gamma_p$  and the  
Quadrant of  $\gamma$

$y''_i - y'_j$	$x''_i - x'_j$	Quadrant	$\gamma$
+	+	I	$\gamma_p$
+	-	II	$\pi + \gamma_p$
-	-	III	$\pi + \gamma_p$
-	+	IV	$\gamma_p$

The coordinates of  $S'_j$  are given by

$$\begin{cases} x_{S'_j} = x'_j + R'_j \cos(\delta + \gamma) \\ y_{S'_j} = y'_j + R'_j \sin(\delta + \gamma). \end{cases}$$

The coordinates of  $S'_k$  are given by

$$\begin{cases} x_{S'_k} = x_{S'_j} + (x_{S_k} - x_{S_j}) \\ y_{S'_k} = y_{S'_j} + (y_{S_k} - y_{S_j}). \end{cases}$$

Finally, the coordinates of  $S_k^{i,j}$  are given by

$$\begin{cases} x_k^{i,j} = x_{S'_k} + \Delta x_{S_j S_k} \\ y_k^{i,j} = y_{S'_k} + \Delta y_{S_j S_k} \end{cases} \quad (D-31)$$

### C. THE $(B_j, B_k)$ PROBLEM

In this problem, Table D-8 corresponds to Table D-7.

TABLE D-8  
Error Terms in the  $(B_j, B_k)$  Problem

<u>Exact or Calculated Quantity</u>	<u>Error Term</u>	<u>Resulting Quantity</u>
$x_k$	$\Delta x_k$	$\left. \begin{aligned} x'_k &= x_k + \Delta x_k \\ y'_k &= y_k + \Delta y_k \end{aligned} \right\} B'_k$
$y_k$	$\Delta y_k$	
$x_j$	$\Delta x_j$	$\left. \begin{aligned} x'_j &= x_j + \Delta x_j \\ y'_j &= y_j + \Delta y_j \end{aligned} \right\} B'_j$
$y_j$	$\Delta y_j$	

TABLE D-8 (continued)

<u>Exact or Calculated Quantity</u>	<u>Error Term</u>	<u>Resulting Quantity</u>
$R_j$	$\Delta R_j$	$R_j + \Delta R_j = R'_j$
$R_k$	$\Delta R_k$	$R_k + \Delta R_k = R'_k$
$x_{S_k} - x_{S_j}$	$\Delta x_{S_j S_k}$	$\left. \begin{matrix} x_{S_j S_k} \\ y_{S_j S_k} \end{matrix} \right\} \xrightarrow{S_j S_k} \text{with error}$
$y_{S_k} - y_{S_j}$	$\Delta y_{S_j S_k}$	
$x_j + (x_{S_k} - x_{S_j})$	$\Delta x_j + \Delta x_{S_j S_k}$	$\left. \begin{matrix} x_j^m \\ y_j^m \end{matrix} \right\} B_j^m$
$y_j + (y_{S_k} - y_{S_j})$	$\Delta y_j + \Delta y_{S_j S_k}$	

The vertices of the triangles correspond as follows:

$B'_k$  corresponds to D

$S'_k$  corresponds to M

$B''_j$  corresponds to N

$$\text{Therefore } d = \overline{S'_k B''_j} = R'_j$$

$$m = \overline{B'_k B''_j}$$

$$= \sqrt{(x'_k - x''_j)^2 + (y'_k - y''_j)^2}$$

$$n = \overline{B'_k S'_k} = R'_k$$

Consequently,  $\delta$  can be calculated as in Chapter IV.

The angle  $\gamma = \angle B_j^m B'_k(x)$  is determined in the same manner as in the  $(B_i, B_j)$  problem, using

$$\gamma_p = \arctan \frac{y_j^m - y'_k}{x_j^m - x'_k} \quad (D-32)$$

and the use of a table similar to Table D-7.

The coordinates of  $S'_k$  are given by

$$x_{S'_k} = x'_k + R'_k \cos(\delta + \gamma)$$

$$y_{S'_k} = y'_k + R'_k \sin(\delta + \gamma)$$

Since  $S_k^{j,k} = S'_k$ , the coordinates of  $S_k^{j,k}$  are given by

$$x_k^{j,k} = x_{S'_k} \quad (D-33)$$

$$y_k^{j,k} = y_{S'_k}$$

#### D. THE $(B_i, B_k)$ PROBLEM

In this problem, the following table corresponds to Table D-6.

TABLE D-9  
Error Terms in the  $(B_i, B_k)$  PROBLEMS

<u>Exact or Calculated Quantity</u>	<u>Error Term</u>	<u>Resulting Quantity</u>
$x_k$	$\Delta x_k$	$x'_k = x_k + \Delta x_k$
$y_k$	$\Delta y_k$	$y'_k = y_k + \Delta y_k$
$x_i$	$\Delta x_i$	$x'_i = x_i + \Delta x_i$
$y_i$	$\Delta y_i$	$y'_i = y_i + \Delta y_i$

TABLE D-9 (continued)

<u>Exact or Calculated Quantity</u>	<u>Error Term</u>	<u>Resulting Quantity</u>
$R_i$	$\Delta R_i$	$R_i + \Delta R_i = R'_i$
$R_k$	$\Delta R_k$	$R_k + \Delta R_k = R'_k$
$x_{S_k} - x_S$	$\Delta x_{SS_k}$	$\left. \begin{matrix} x_{SS_k} \\ y_{SS_k} \end{matrix} \right\} \xrightarrow{\text{SS}_k \text{ with error}}$
$y_{S_k} - y_S$	$\Delta y_{SS_k}$	
$x_i + (x_{S_k} - x_S)$	$\Delta x_i + \Delta x_{SS_k}$	$\left. \begin{matrix} x_i^m \\ y_i^m \end{matrix} \right\} B_i^m$
$y_i + (y_{S_k} - y_S)$	$\Delta y_i + \Delta y_{SS_k}$	

The vertices of the triangles correspond as follows:

$B'_k$  corresponds to D

$S'_k$  corresponds to M

$B_i^m$  corresponds to N

$$\text{Therefore, } d = \overline{S'_k B_i^m} = R'_i$$

$$m = \overline{B'_k B_i^m}$$

$$= \sqrt{(x_i^m - x'_k)^2 + (y_i^m - y'_k)^2}$$

$$n = \overline{B'_k S'_k} = R'_k$$

Consequently,  $\delta$  can be calculated as in Chapter IV.

The angle  $\gamma = \angle B_i^m B'_k (x)$  is determined in the same manner as in the  $(B_i, B_j)$  problem, using

$$\gamma_p = \arctan \left( \frac{y_i^m - y'_k}{x_i^m - x'_k} \right) \quad (D-34)$$

and the use of a table similar to Table D-7.

The coordinates of  $S'_k$  are given by

$$\begin{cases} x_{S'_k} = x'_k + R'_k \cdot \cos(\delta + \gamma) \\ y_{S'_k} = y'_k + R'_k \cdot \sin(\delta + \gamma) \end{cases}$$

Since  $S_k^{i,k} = S'_k$ , the coordinates of  $S_k^{i,k}$  are given by

$$\begin{cases} x_k^{i,k} = x_{S'_k} \\ y_k^{i,k} = y_{S'_k} \end{cases} \quad (D-35)$$

## VI. SOLUTION OF THE PROBLEM ON A DIGITAL COMPUTER

The exact solution of the three-beacon problem offers no difficulties when programmed for a digital computer such as the IBM 7090. The use of FORTRAN is recommended because of its greater ease of programming, and also because parts of the program can be done earlier on the IBM 1620 and perhaps result in less overall programming and checkout time. FORTRAN programs run approximately as fast as those that are programmed conventionally.

The solutions of the two-beacon problems on a digital computer offer no difficulties either. The  $(B_1, B_k)$  problem (Chapter V, Section D) is essentially the general two-beacon problem with the error terms  $\Delta x_{SS_k}$  and  $\Delta y_{SS_k}$  chosen randomly, rather than as the sums of two random values (Table D-3 for  $\overrightarrow{SS_k}$ ).

The purpose of putting this problem on a digital computer is to enable the rapid and easy collection of a sample of the points estimating  $S_k$  in order to make decisions. The sample is analyzed statistically and the results used in the decision-making process. The output of the computer program and the statistical analysis are discussed in the next chapter.

VII. STATISTICAL CALCULATIONS AND  
COMPUTER PROGRAM OUTPUT

For one set of input data which defines an exact three-beacon problem (one set of standard deviations of the error terms, and an assumed form of the distribution of each error) a sample of, say  $N = 100$  values of the  $x$  and  $y$  deviations from  $S_k$  is obtained. This sample is used to determine which gives the best estimate of  $S_k$ : the deviations obtained by the use of one of the three two-beacon problems or the deviations obtained by taking the mean values of those deviations. In order to compare these four estimates, it is desirable to plot each on a rectangular system with the same scale. Certain statistical calculations which summarize and characterize each set of results must be made. These are the  $x$  and  $y$  means and standard deviations, and their correlation coefficients. All these plots and calculations can be easily done as part of a digital computer program.

It is wise to consider having the computer program produce more output than may be considered necessary at the time the program is written. Certainly all the input data and assumptions must be printed out, and the values calculated in the solution of the exact three-beacon problem. Since the deviations from  $S_k$  will be plotted, it is questionable whether they need be printed.

### VIII. USE OF THE RESULTS

Each two-beacon problem results in a sample of points estimating  $S_k$ , or preferably a sample of the deviations about  $S_k$ , resulting from a random selection of errors applied to the variable parts in the three-beacon problem. The three samples are also combined to give a fourth sample and the four are compared and contrasted to determine if one of them estimates  $S_k$  better and is more consistent with results expected from the assumptions than the other three. Several three-beacon problems must be studied in this way and compared to determine any tendency for one estimate to be optimum from problem to problem. New ideas and refinements of this problem will undoubtedly arise as results accumulate and are compared.

The results of this problem will be compared with the results of the analytical model of the three-beacon problem based on a linearity assumption. One outcome from this comparison will be the determination of the range of values for the variables over which the analytical model gives results which are substantially the same as those given by the computer model.

The third purpose of this problem is to study the effect of a change in one variable and to compare such effects in order to determine which variables are more sensitive or critical.

The general purpose of the problem presented in this report is to study a type of maximum error in position estimation. This is done by having the submarine move away from the beacon whose ping arrives last. If the problem is changed by the apparently minor detail of having the submarine move toward that beacon, the condition  $T_2 \leq T_3$  may not hold under all other conditions. This variation in the present problem may give an estimate of the minimum error to be expected, but it will certainly involve additional analysis, due to the possible failure of the above condition.

It is expected that the computer simulation will be done in such a way as to facilitate changing the form of distribution of a given error variable. It may be desirable to compare different distributions for one error variable, or to use experimental data to estimate a distribution, which might be better than one done by a theoretical distribution.

IX. OTHER APPLICATIONS AND RELATED PROBLEMS

The subject of this report has been oriented around the problem of the location of a submarine's position by use of range estimation calculations. There are other applications that can be made by replacing the submarine and its characteristics by some other object, or by replacing the submarine and the environmental (oceanic) characteristics.

One specific application would be the problem of position location based on bearing measurements of electromagnetic radiations. The present problem could be used with little change by converting the bearing information to range information.

X. RANDOM SELECTION OF A VALUE FROM A  
STANDARD NORMAL DISTRIBUTION

In case a normal distribution is used as a rough approximation to the (unknown) distribution of a variable, and many random values of the variable are to be chosen in the course of a problem run, considerable computer time (IBM 7090) may be used unnecessarily if a very accurate method of random selection is used. The following method is submitted as an alternate method of random selection of values from the standard normal distribution, values being limited between -3 and +3.

Table D-10 lists positive values of the standard normal variable,  $x$ , from 0 to 3, the values being chosen so that the cumulative probability is the same between successive values of  $x$ .

The random selection of  $x$  is made by first choosing a uniformly distributed random number,  $y$  (fixed point) by use of Rotenberg's\* additive algorithm  $y = (2^9 + 1) y_0 + 1$  where  $y_0$  is the value of the previous random number chosen. Bit positions 29 to 35 are examined. If they are all zeros, let  $x = 0.0$  be the random number chosen for use in the calculations. If bit 29 is a 1 and all the others are zeros, use  $y$  as  $y_0$  to select a new value of  $y$  by the algorithm. If bit 29 is a zero, but bits 30 to 35 are not all zeros, use them as an index register value to choose a value of  $x$  from the table. If bit 29 is a 1, and bits 30 to 35 are not all zeros, use them as an index register as above, then change the sign of the  $x$  chosen. The  $x$  is then multiplied by the standard deviation of the particular distribution concerned to obtain a random value from that distribution.

For use of part of this, for example the two-beacon problem, on the IBM 1620, a different method of selecting the random number must be used, but Table 10 can be used if the random number is an integer between -63 and +63 inclusive.

---

\*Rotenberg, A., "A New Pseudo Random Number Generator," Journal of the Association for Computing Machinery, January 1960, pp 75 to 77.

TABLE D-10

Values of the Standard Normal Variable from  $x = 0$  to  $x = 3$   
with Equal Increments of Cumulative Probability  
Between Successive Values of  $x$

<u>Index</u>	<u>Value of x</u>	<u>Index</u>	<u>Value of x</u>
0	0.0	32	0.68486
1	0.01984	33	0.71016
2	0.03969	34	0.73593
3	0.05956	35	0.76219
4	0.07944	36	0.78900
5	0.09936	37	0.81638
6	0.11932	38	0.84439
7	0.13933	39	0.87307
8	0.15939	40	0.90249
9	0.17952	41	0.93272
10	0.19972	42	0.96382
11	0.22000	43	0.99589
12	0.24038	44	1.0290
13	0.26085	45	1.0633
14	0.28143	46	1.0989
15	0.30214	47	1.1359
16	0.32297	48	1.1746
17	0.34395	49	1.2151
18	0.36507	50	1.2577
19	0.38636	51	1.3027
20	0.40783	52	1.3506
21	0.42949	53	1.4017
22	0.45135	54	1.4568
23	0.47343	55	1.5167
24	0.49574	56	1.5826
25	0.51830	57	1.6562
26	0.54113	58	1.7400
27	0.56425	59	1.8383
28	0.58767	60	1.9583
29	0.61142	61	2.1158
30	0.63551	62	2.3549
31	0.65998	63	3.0000

CONFIDENTIAL

E-1

APPENDIX E

DEVELOPMENT AND EVALUATION OF THE  
NAVIGATION EQUATION

CONFIDENTIAL  
ER 12316

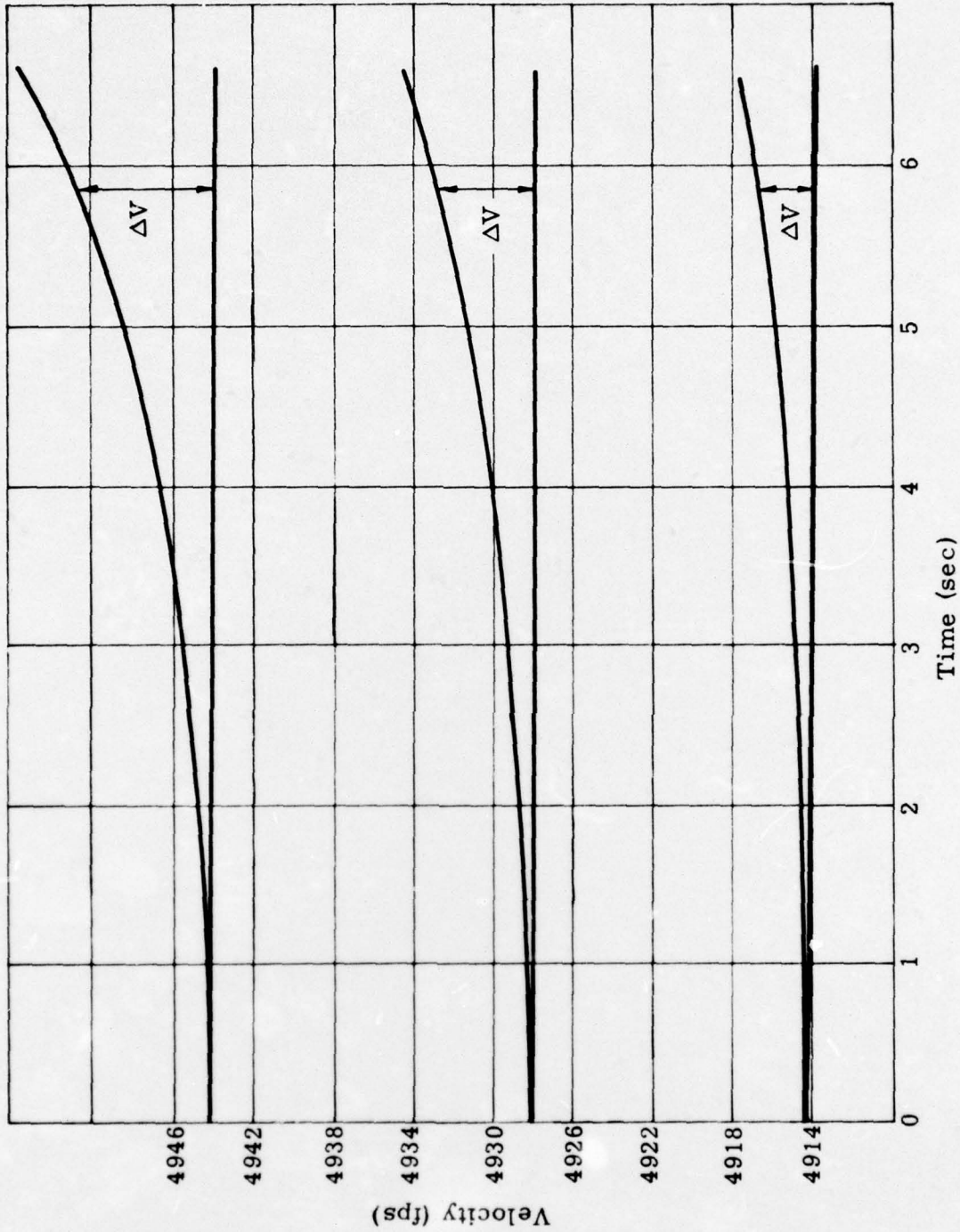

Fig. E-1. Variation for the Average Depth Velocity Profile

The following equation, which is a form of the general navigation equation, was derived for determining the horizontal distance (X) from the source when the direct path is utilized.

$$R = \sqrt{\left[ (VA + K_8 d_R + K'_1 + K_2 t + K_3 t^2) t \right]^2 - \left[ d'_s - d_R \right]^2} \quad (1)$$

Definitions:

R = Horizontal distance from source (ft)

VA = Average velocity of sound--measured vertically, source to surface (fps)

$K_1 = VA + K'_1$

$d'_s = (d_r - d_s) =$  Source depth (ft)

$d_R =$  Receiver depth (ft)

t = Source to receiver transit time (sec)

$\Delta V = K'_1 + K_2 t + K_3 t^2$

The average velocity of sound varies as a function of the horizontal range (or travel time); Fig. E-1 shows this variation for the average depth-velocity profile.

The equations that approximate the change in velocity ( $\Delta V$ ) are given as:

$$d_R = 0 \quad \Delta V = 0.06428 - 0.17857 t + 0.1999998 t^2$$

$$d_R = 800 \text{ ft} \quad \Delta V = -0.038095 - 0.22857 t + 0.166666 t^2$$

$$d_R = 1500 \text{ ft} \quad \Delta V = -0.032143 - 0.08214265 t + 0.1142856 t^2$$

An initial decision was made to let the equation for  $d_R = 800$  ft become representative for all conditions.

A computer program was set up with Eq (1) where the constants are as follows:

$$K_8 = -0.02$$

$$K_3 = 0.167$$

$$K_1' = -0.038$$

$$ds' = 5185 \text{ ft}$$

$$K_2 = -0.228$$

$$d_R = 1500, 800, 400 \text{ and } 0 \text{ ft}$$

$$VA = 4944.00 \text{ fps (average D-V profile)}$$

$$VA = 4942.4455 \text{ (minimum D-V profile)}$$

$$VA = 4945.9334 \text{ (maximum D-V profile)}$$

The following is a summary of the results obtained from Eq (1).

#### A. AVERAGE DEPTH-VELOCITY PROFILE

##### 1. Source depth ( $d_R$ ) = 0

Horizontal Distance (R)	Computer Distance (Rc)	Error (ft)
9,364	9,360.87	-3.1
10,933	10,929.11	-3.9
12,966	12,960.45	-5.5
15,811	15,802.36	-8.6
20,493	20,476.15	-16.8
28,407	28,361.77	-45.2

##### 2. $d_R = 400 \text{ ft}$

Horizontal Distance (R)	Computer Distance (Rc)	Error (ft)
8,568	8,567.88	-0.1
9,976	9,975.98	0

<u>Horizontal Distance (R)</u>	<u>Computer Distance (Rc)</u>	<u>Error (ft)</u>
11,778	11,777.02	-1.0
14,237	14,234.93	-2.1
18,011	18,004.76	-6.2
22,414	22,400.57	-13.4

3.  $d_R = 800$  ft

7,795	7,794.75	-0.2
9,056	9,056.02	0
10,654	10,653.86	-0.1
12,799	12,797.39	-1.6
15,962	15,958.18	-3.8
19,297	19,290.07	-6.9

4.  $d_R = 1500$  ft

6,472	6,471.22	-0.8
7,493	7,492.51	-0.5
8,769	8,767.83	-1.2
10,439	10,437.19	-1.8
12,785	12,782.07	-2.9
15,047	15,043.27	-3.7

#### B. MINIMUM DEPTH-VELOCITY PROFILE

1.  $d_R = 0$

<u>Horizontal Distance (R)</u>	<u>Computer Distance (Rc)</u>	<u>Error (ft)</u>
9,346	9,344.02	-2.0
10,345	10,342.24	-2.8

CONFIDENTIAL

<u>Horizontal Distance (R)</u>	<u>Computer Distance (Rc)</u>	<u>Error (ft)</u>
11,513	11,510.43	-2.6
12,916	12,911.72	-4.3
14,655	14,649.83	-5.2
16,922	16,914.72	-7.3
20,145	20,133.02	-12.0
25,847	25,822.75	-24.3
33,530	33,478.58	-51.4

2.  $d_R = 400$  ft

8,564	8,561.57	-2.4
9,466	9,463.62	-2.4
10,517	10,513.68	-3.3
11,768	11,764.02	-4.0
13,303	13,297.65	-5.3
15,267	15,259.82	-7.2
17,960	17,949.92	-10.1
22,256	22,238.95	-17.0
26,335	26,306.92	-28.1

3.  $d_R = 800$  ft

7,793	7,790.1	-2.9
8,602	8,599.58	-2.4
9,540	9,537.10	-2.9
10,649	10,645.62	-3.4
11,996	11,990.99	-5.0
13,689	13,683.39	-5.6
15,939	15,931.29	-7.7
19,244	19,231.51	-12.5
21,732	21,715.16	-16.8

4.  $d_R = 1500$  ft

The results are the same as computed in Section A-4.

## C. MAXIMUM DEPTH-VELOCITY PROFILE

1.  $d_R = 0$

Horizontal Distance (R)	Computer Distance (Rc)	Error (ft)
9,382	9,379.00	3.0
10,393	10,389.92	3.1
11,582	11,577.80	4.2
13,018	13,012.21	5.8
14,820	14,812.15	-7.8
17,228	17,216.28	-11.8
20,922	20,901.25	-20.8
24,272	24,238.50	-33.5

2.  $d_R = 400$  ft

8,577	8,578.78	1.8
9,483	9,485.35	2.4
10,541	10,542.24	1.2
11,802	11,803.51	1.5
13,356	13,356.30	0.3
15,358	15,353.48	-4.5
18,148	18,144.34	-3.7
20,108	20,100.57	-7.4

3.  $d_R = 800$  ft

7,796	7,800.08	4.1
8,607	8,611.18	4.2
9,547	9,551.03	4.0
10,659	10,662.96	4.0

CONFIDENTIAL

Horizontal Distance (R)	Computer Distance (Rc)	Error (ft)
12,010	12,013.95	3.9
13,713	13,716.50	3.5
15,984	15,986.4	2.4
17,471	17,471.54	0.5

Equation (1) was next modified to let  $\Delta V$  for  $d_R = 0$  become representative for all conditions, thus

$$R = \sqrt{\left[ (VA - 0.02 d_R - 0.038 - 0.1785 t + 0.2t^2) t \right]^2 - \left[ ds' - d_R \right]^2} \quad (2)$$

The following is a summary of the results where \*E is the error obtained from the previous program and  $E_2$  the error resulting from Eq (2).

#### D. AVERAGE DEPTH-VELOCITY PROFILE

##### 1. Source Depth ( $d_R$ ) = 0

Horizontal Distance (R)	Computer Distance (Rc)	Error $E_2$	Error *E
9,364	9,361.52	-2.5	-3.1
10,933	10,929.97	-3.0	-3.9
12,966	12,961.68	-4.3	-5.5
15,811	15,804.27	-6.7	-8.6
20,493	20,479.73	-13.3	-16.8
28,407	28,370.11	-36.9	-45.2

##### 2. $d_R = 400$ ft

8,568	8,568.40	+0.4	-0.1
9,976	9,976.67	0.7	0
11,778	11,777.99	0	-1.0
14,237	14,236.39	-0.6	-2.1

CONFIDENTIAL  
ER 12316

<u>Horizontal Distance (R)</u>	<u>Computer Distance (Rc)</u>	<u>Error E<sub>2</sub></u>	<u>Error *E</u>
18,011	18,007.32	-3.2	-6.2
22,414	22,405.02	-9.0	-13.4
3. d <sub>R</sub> = 800 ft			
7,795	7,795.17	+0.2	-0.2
9,056	9,056.56	0.6	0
10,654	10,654.61	0.6	-0.1
12,799	12,798.51	-0.5	-1.6
15,962	15,960.05	-1.9	-3.8
19,297	19,293.07	-3.9	-6.9
4. d <sub>R</sub> = 1500 ft			
6,472	6,471.48	-0.5	-0.8
7,493	7,492.85	-0.1	-0.5
8,769	8,768.30	-0.7	-1.2
10,439	10,437.86	-1.1	-1.8
12,785	12,783.13	-1.9	-2.9
15,047	15,044.84	-2.2	-3.7

## E. MINIMUM DEPTH-VELOCITY PROFILE

1. d<sub>R</sub> = 0

<u>Horizontal Distance (R)</u>	<u>Computer Distance (Rc)</u>	<u>Error E<sub>2</sub></u>	<u>Error *E</u>
9,346	9,344.67	-1.3	-2.0
10,345	10,343.02	-2.0	-2.8
11,513	11,511.39	-1.6	-2.6
12,916	12,912.93	-3.1	-4.3
14,655	14,651.44	-3.6	-5.2
16,922	16,916.97	-5.0	-7.3

<u>Horizontal Distance (R)</u>	<u>Computer Distance (Rc)</u>	<u>Error E<sub>2</sub></u>	<u>Error *E</u>
20,145	20,136.46	-8.5	-12.0
25,847	25,829.26	-17.7	-24.3
33,530	33,491.64	-38.4	-51.4

2.  $d_R = 400$  ft

8,564	8,562.09	-1.9	-2.4
9,466	9,464.25	-1.8	-2.4
10,517	10,514.44	-2.6	-3.3
11,768	11,764.98	-3.0	-4.0
13,303	13,298.91	-4.1	-5.3
15,267	15,261.54	-5.5	-7.2
17,960	17,952.47	-7.5	-10.1
22,256	22,243.33	-12.7	-17.0
26,335	26,313.72	-21.3	-28.1

3.  $d_R = 800$  ft

7,793	7,790.52	-2.5	-2.9
8,602	8,600.08	-1.9	-2.4
9,540	9,537.70	-2.3	-2.9
10,649	10,646.36	-2.6	-3.4
11,996	11,991.95	-4.0	-5.0
13,689	13,684.69	-4.3	-5.6
15,939	15,933.16	-5.8	-7.7
19,244	19,234.50	-9.5	-12.5
21,732	21,719.24	-12.8	-16.8

4.  $d_R = 1500$  ft

The results are the same as computed in Section D-4.

## F. MAXIMUM DEPTH-VELOCITY PROFILE

<u>Horizontal Distance (R)</u>	<u>Computer Distance (Rc)</u>	<u>Error E<sub>2</sub></u>	<u>Error *E</u>
1. $d_R = 0$			
9,382	9,379.65	-2.4	3.0
10,393	10,390.71	-2.3	3.1
11,582	11,578.77	-3.2	4.2
13,018	13,013.44	-4.6	5.8
14,820	14,813.80	-6.2	-7.8
17,228	17,218.62	-9.4	-11.8
20,922	20,905.02	-17.0	-20.8
24,272	24,244.01	-28.0	-33.5
2. $d_R = 400$ ft			
8,577	8,579.30	2.3	1.8
9,483	9,485.98	3.0	2.4
10,541	10,543.00	2.0	1.2
11,802	11,804.47	2.5	1.5
13,356	13,357.56	1.6	0.3
15,358	15,354.60	-3.4	-4.5
18,148	18,146.95	-1.1	-3.7
20,108	20,103.94	-4.1	-7.4
3. $d_R = 800$ ft			
7,796	7,800.49	4.5	4.1
8,607	8,611.68	4.7	4.2
9,547	9,551.63	4.6	4.0
10,659	10,663.71	4.7	4.0
12,010	12,014.92	4.9	3.9
13,713	13,717.81	4.8	3.5
15,984	15,988.28	4.3	2.4
17,471	17,473.88	2.9	0.5

UNCLASSIFIED

~~CONFIDENTIAL~~

UNCLASSIFIED

The worst error was -38 ft which was obtained at a depth of 0 ft and a horizontal range of 5.5 mi. Since this error increases as 0 depth is approached, the error at 150 ft of depth will be approximately the average error between 400 ft (-21 ft) and 0 ft which is about -30 ft. It can also be noticed that all the errors derived from Eq (2) are essentially negative and by biasing the answer or modifying the constants, the errors can be made to be on the order of  $\pm 18$  ft instead of +5 and -30 ft, as is now the case.

The errors for the single-bounce path will be approximately three times the errors for the direct path (for three times the range) since the source-to-surface ray paths repeat themselves exactly three times except for bottom depth variations. This means the errors would be on the order of  $\pm 60$  ft at the maximum range. This is sufficiently close such that the values of the constants determined above should be used until the accuracy portion of the range implementation, where more accurate and representative values can be determined by test.

620413-0250

UNCLASSIFIED

~~CONFIDENTIAL~~

ER 12316