

AD-A031 866

DEFENCE RESEARCH ESTABLISHMENT OTTAWA (ONTARIO)
NICKEL/CADMIUM AIRCRAFT BATTERIES: HIGH RATE DISCHARGE EQUIPMEN--ETC(U)
SEP 76 K FELDMAN, R L HAINES, W LEPAGE

F/G 10/3

UNCLASSIFIED

DREO-TN-76-22

NL

| OF |
AD
A031 866



END
DATE
FILMED
12-76

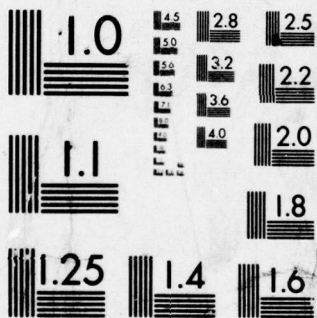

MICROCOPY RESOLUTION TEST CHART
NATIONAL BUREAU OF STANDARDS-1963-A

RESEARCH AND DEVELOPMENT BRANCH

DEPARTMENT OF NATIONAL DEFENCE
CANADA

11 Sep 76

12 25 p.

DEFENCE RESEARCH ESTABLISHMENT OTTAWA ✓

9 TECHNICAL NOTE NO. 76-22 ✓

14 DREO-TN-76-22

6 NICKEL/CADMIUM AIRCRAFT BATTERIES:
HIGH RATE DISCHARGE EQUIPMENT.

10 by K. Feldman, R.L. Haines & W. LePage (Capt.)
Electrical Power Sources Division

ACCESSION by	
RTIS	White Section <input checked="" type="checkbox"/>
DOC	Buff Section <input type="checkbox"/>
UNANNOUNCED	<input type="checkbox"/>
JUSTIFICATION	
BY	
DISTRIBUTION/AVAILABILITY CODES	
Dist.	AVAIL and/or SPECIAL
A	

RECEIVED SEPTEMBER 1976
PUBLISHED OCTOBER 1976
OTTAWA

PROJECT NO.
54-03-07

*On contract from Computing Devices Company.

76-154

404 576 out

ABSTRACT

Factors that are not of major significance in low rate battery discharges become quite important when a battery is used to crank an aircraft turbine engine. Apparatus was designed and built to facilitate the study of nickel/cadmium aircraft batteries when used in this and other high rate applications. Maximum discharge rates of 1000 amperes or more are possible with 24-volt batteries. Load configurations may be readily modified. Discharge profiles are simulated by use of fixed load steps which may be timed either automatically or manually. This document describes the equipment and gives instructions for its use.

RÉSUMÉ

Certains facteurs, secondaires pour les décharges de faible puissance, peuvent devenir très importants lorsqu'une batterie sert à mettre en marche le turbo-moteur d'un aéronef. Nous avons mis au point un appareil pour simuler ces opérations et d'autres nécessitant de fortes décharges pour étudier le comportement des batteries nickel/cadmium pour aéronefs.

L'appareil permet d'obtenir une décharge d'une intensité supérieure à 1000 ampères avec des batteries de 24 volts. On peut aisément modifier la charge. Il est également possible de simuler des profils de décharge en employant des résistances fixes, appliquées par étapes et déclenchées manuellement ou automatiquement à intervalles prédéterminés. Le présent rapport décrit les composantes de cet appareil et en donne les instructions d'exploitation.

TABLE OF CONTENTS

	<u>Page</u>
<u>ABSTRACT/RÉSUMÉ</u>	(i)
<u>INTRODUCTION</u>	1
<u>GENERAL DESCRIPTION</u>	1
<u>RESISTOR BANK</u>	2
OPERATION OF THE RESISTOR BANK	3
<u>CAUTION</u>	3
<u>THE CONTROL SYSTEM</u>	4
CONTROL CIRCUIT DETAILS.	5
<u>DATA OUTPUT</u>	6
<u>OPERATING INSTRUCTIONS</u>	7
TIMING ADJUSTMENTS	8
<u>APPENDIX I: EQUIVALENT RESISTANCES</u>	11
<u>APPENDIX II: CURRENT-TIME CURVE SIMULATION</u>	13
<u>TABLE I: Connector Wiring</u>	14
Figure 1: System Block Diagram	15
2: Resistor Bank.	16
3: Resistor Location Diagram.	17
4: Control Panel.	18
5: Control Circuit.	19
6: Engine Start Curve	20

INTRODUCTION

The cranking time for an aircraft turbine engine is typically 20 to 30 seconds. During this time the current in the starter motor circuit may vary from approximately 1000 amperes down to a few hundred or less. Under such circumstances effects of battery resistance, the nature of battery heating, etc., assume significance that is considerably different from that in lower rate applications. To facilitate study of battery behaviour in high rate applications a test unit which is capable of such rates was designed and built.

The unit, designed for use with a 19 or 20 cell nickel/cadmium aircraft battery, is capable of drawing currents of the required magnitudes and can give stepwise simulation of the current profiles experienced in turbine engine starting. The load profile desired is provided by a series of automatically timed constant resistance steps. These constant load steps facilitate analysis of the data obtained. Current, voltage, and other parameters as required are recorded on strip chart recorders during the discharge.

The load bank is made up of suitable resistors interconnected primarily in parallel. Each may be switched in or out by means of a solenoid operated switch. Manual control of discharge sequences is possible. A general description of the design follows. More detailed discussions are given in subsequent sections.

GENERAL DESCRIPTION

A block diagram of the system is shown in Figure 1. The resistor bank provides the load through which the battery under test is discharged. The individual resistors are switched in and out of the circuit by the solenoid operated switches. These switches are controlled from the control unit.

The control unit includes a timer system which can be adjusted to time individual steps of the discharge as required. The preset system enables the operator to select the resistors needed at the start of the discharge. Operation of the discharge button then causes all of the solenoid operated

switches relating to the selected resistors to close simultaneously. They subsequently open individually and automatically under control of the timer system.

The control panel includes switches needed to carry out the above operations and to permit manual rather than automatic operation when desired. Lights are used to indicate "selected" resistors, on-off states, etc.

The block labelled "Auxiliaries" in the diagram includes facilities for operating event markers and an electric timer if desired.

A multiconductor cable links the resistor bank unit to the control unit. This cable provides the connections for operation of the solenoids and for measurement of current and voltage.

RESISTOR BANK

The resistor bank, shown in Figures 2 and 3, is made up of 18 (r_1 to r_{18}) ribbons of a special alloy which has a very low temperature co-efficient of resistance. Each ribbon has a nominal resistance of 50 milliohms. They are interconnected to form 8 resistors, R1 to R8, as follows:

R1:	r_1 and r_2 in series to give	100	m Ω
R2:	r_3 and r_4 in series to give	100	m Ω
R3:	r_5 and r_6 in series to give	100	m Ω
R4:	r_7 to give	50	m Ω
R5:	r_8 to give	50	m Ω
R6:	r_9 and r_{10} in parallel to give	25	m Ω
R7:	r_{11} , r_{12} , r_{13} , r_{14} in parallel to give	12.5	m Ω
R8:	r_{15} and r_{16} , each center tapped and the 4 portions in parallel to give	6.25	m Ω

Spares: r_{17} , r_{18} unwired.

In the base mode, R1 to R8 inclusive are wired with one end common for use as parallel components of the total load. The other ends of the resistors are connected to remotely controlled solenoid operated switches. The switches, in turn, are connected to another common line to complete the parallel network. Resistors R7 and R8 are themselves made up of double parallel branches. Each of these resistors uses two solenoid switches, one in each branch, to reduce the load carried per switch. However, each combination is operated as a single unit by the control circuits.

The solenoid switches used are 12 volt automotive "starter solenoids" identified as Ford AMCO #F496 (Canadian Tire Corporation #196253).

In addition to the base mode, two other resistor configurations have been found useful. In one of these, mode 2, the bolted interconnections are altered to remove R8 from the parallel configuration and to connect it in series with the parallel bank. The solenoid switches for R8 are not needed so are omitted in this configuration. See Figure 2. For mode 3, shorting links are bolted in to short circuit r_1 , r_2 and r_3 . This reduces R1, R2 and R3 to 50 m Ω each. Mode 3 may be combined with mode 2 if desired. The combination is referred to as mode 4 below. See Appendix 1 for total resistances of the basic combinations. The interconnections in the resistor bank are shown in Figure 2, arranged to aid in locating the desired points in the actual structure.

OPERATION OF THE RESISTOR BANK

Use of the resistor bank is conveniently illustrated by discussion of an engine start simulation. The normal current profile in a turbine engine start commences with a current maximum and falls off in a skewed S curve manner as the turbine starts to rotate. This is simulated in a stepwise manner by starting the discharge with a maximum required number of resistors in parallel to give the required peak current. After a suitable length of time, say 2 seconds, one or more resistors are switched out of the circuit to lower the current by a suitable step. This process is repeated at selected variable intervals of time to give a series of current steps which adequately simulates the desired smooth current profile.

The switching sequence normally proceeds in the reverse of the resistor numbering sequence, eg. R8 is switched off first, then perhaps R7 and R6, then R5 etc. Controls are numbered to correspond to the resistor numbering. A detailed example is given in Appendix 2.

CAUTION

Departures from the above switching sequence are possible. However, since the battery internal resistance may be of the same order of magnitude or even larger than the total resistor load, the current flowing in any one resistor is greatly influenced by the combination of the remaining resistors. Care must therefore be exercised to ensure that excessive dissipation in some circuits does not result when an unusual sequence is used. Similar considerations enter into any rearrangement of the resistor interconnection configuration. The choice of R8 to be used in series with the rest of the bank in mode 2, for example, hinges on the fact that the total current is divided amongst the four parallel branches of R8 and thus keeps the dissipation in each branch within bounds.

THE CONTROL SYSTEM

The function of the control system is to suitably control the switching in and out of the resistors in the bank. This it does by activating the solenoid switches mentioned above. The solenoid switches are located in close proximity to their associated resistors. The rest of the control system is located in a metal cabinet which is connected to the structure housing the resistor bank by means of a multiconductor cable.

Figure 4 shows the operator's panel on the control cabinet. For each resistor in the resistor bank there is an arming switch and a standby push-button. To initiate a discharge, the arming switches for all of the desired resistances are closed and the corresponding standby push buttons are operated. Subsequently the discharge button at the top right hand corner of the panel is operated. This causes all of the solenoids in the activated circuits to close simultaneously and initiates the discharge. At the same time a synchronous motor is started. This drives a cam operated switching system which times the respective steps in the discharge and switches off the appropriate solenoids for each step.

The "emergency stop" makes it possible to terminate the discharge manually. When it is operated it causes all solenoid switches to open immediately. The arming switches make it possible to manually open any individual solenoid switch (or to close it provided the corresponding standby circuit and the discharge button had both been previously operated). In such manual operations, the timer switch may be opened to eliminate the automatic system if desired.

A more detailed discussion of the control system is given in the next section.

The control panel includes a row of light bulbs below the row of arming switches. Each of these is connected across the contacts of the corresponding solenoid switch. If a battery is plugged in and a solenoid is open, the battery voltage appears across the contacts and energizes the bulb. If the solenoid switch is closed the lamp is short circuited and no voltage is applied to it. These lamps were included in the design to provide rapid indication and identification for anticipated emergencies in which the contacts in the solenoid switch might weld shut and hence remain "on" when power to the solenoid is removed. (However, after extensive use it was noted that this never occurred and the light bulbs were removed from the sockets to eliminate the associated battery drain during standby periods).

CONTROL CIRCUIT DETAILS

A schematic diagram of the control circuits is given in Figure 5. The coils for the solenoid operated switches are indicated as SS1 to SS8. The basic function of the circuits described here is to operate these solenoids in the desired manner.

A 30-ampere, 12-volt dc power supply (external to the equipment described here) provides power to operate the solenoids through the contacts of K12, K1, etc. and through switches S1, etc. The latter switches are manually closed (and may be used for manual control of individual solenoids if desired). The K1 to K8 sets of contacts are closed by operation of the respective associated standby push buttons. Momentary closure of the push button energizes the corresponding relay coil which causes the contacts (eg. K1 contacts) to close. One set of these contacts is wired in parallel with the push button, hence locks the relay in the energized position. At this time the cam operated switches shown next to the KK1 - KK8 relay coils are in the closed position.

When all of the desired S1 - S8 switches have been closed and the corresponding KK1 - KK8 relays locked in, the discharge push button (shown beside the K10 contacts in the diagram) may be operated. This causes KK10 to lock in and one set of its contacts causes the heavy duty relay KK12 to be energized. Contacts K12 then cause all of the selected solenoids to be simultaneously* energized by the 12-volt power supply.

Another set of contacts on KK10 energizes the cam motor M which thus starts timing the "discharge". As the preset time for each resistor is reached, the corresponding cam operated switch (shown on the left in Figure 3) is opened. Each relay, KK1, etc., is de-energized and opens the corresponding solenoid circuit. This in turn removes the associated resistor for the discharge circuit.

A few seconds after the start of the timing cycle a cam closes the switch for relay KK9. This relay is thus energized and its contacts closed to form a circuit parallel to the K10 contacts which put the cam motor into operation. When the discharge cycle is ended the cam for KK10 de-energizes the latter thus disconnecting the 30-ampere power supply from all solenoid circuits. However, the K9 contacts remain closed. This permits the cam motor to continue running until the KK9 cam de-energizes the KK9 relay. This position of the cam system constitutes the zero of the timing system which is then ready for a subsequent cycle.

* The term "simultaneously" is here used in a general way and is applicable in the engine starting simulation. However, if the switch operations are observed on a cathode ray oscilloscope in a "millisecond" time frame it will be noted that not only do the closing times vary from switch to switch, but each may "bounce" several times before firm closure is attained.

An additional relay, KK11, is operated by a set of contacts on K10 and hence is energized during the period of the "discharge". The K11 contacts are connected to external binding posts to serve as an event marker if desired.

Should it be desired to terminate a discharge cycle suddenly (as in an emergency, for example), operation of the stop push button (lower left on the diagram) immediately de-energizes all of the relays and releases the lock-in circuits. After release of the push button, KK9 re-energizes and returns the cam system to its zero position.

Directions to assist in adjusting the cams for desired discharge profiles are given in the section on "Timing Adjustment".

Details relating to the cable which connects the control unit to the resistor bank unit are given in Table I.

DATA OUTPUT

Provisions are made for the following outputs:

(a) Voltage

Two leads sense battery voltage at the Elcon connector for the battery and terminate directly on two binding posts on the control panel. Any meter or recorder with high input resistance and suitable scale may be used to measure the battery voltage at the binding posts any time the battery is plugged in.

(b) Current

A shunt* in series with one of the current leads to the battery provides the current sensing facility. Its output is brought out to the "current"

* Weston Shunt S/N 56580 was tested at Quality Engineering Test Establishment, Hull, P.Q., in Aug. 1972: resistance at 25°C: 0.0999 milliohms; temperature coefficient (manganin) approximately 0.01 milliohm per celsius degree per ohm. A temperature of 200°C was reached after 3 minutes at 960 amperes and voltage indication increased from 96 mV to 97.7 mV, i.e. less than 2%. Normal use in the present apparatus would, of course, never involve currents of this magnitude for more than a few seconds.

binding posts on the control panel and may be measured with an appropriate millivolt meter (100 mV = 1000 A).

(c) Event Marker

These two binding posts are connected to isolated relay contacts which are closed during the time of discharge only (See Figure 5, K11).

(d) Timed AC Output

A 2-pin Jones Connector at the left hand side of the control panel provides 117 Vac Power (via light relay contacts) during discharge time only. If a suitable 60-Hz timer is available, this power may be used for precise measurement of timing adjustments. However, the timing mechanism must be capable of switching on and off without "coasting". A button labelled "reset" beside the above outlet may be depressed to provide the AC power when a discharge is not in progress to permit resetting the external timing device if this is necessary.

OPERATING INSTRUCTIONS

This section illustrates the use of the equipment in a typical experiment, such as the simulation of a turbine engine start. It is assumed that the desired current-time curve is as shown in Figure 6. Procedures for other uses of the equipment should be apparent after the basic arrangement is understood. In the above example proceed as follows:

1. Determine a suitable stepped profile made up of straight line segments which approximates the current-time curves. The segments must be selected such that the current steps may be obtained with the available resistor combinations (Appendix 1). Determine the time intervals appropriate to each segment. Such a stepped curve is shown in Figure 6 and the related data are tabulated in Appendix 2.
2. Make resistor interwiring changes if necessary to obtain the selected mode.
3. Adjust the timing cams to give the desired time sequence. The procedure for this is given below in the section on "Timing Adjustment".
4. Assemble and connect all desired measuring and recording apparatus and set to the desired speeds, ranges etc. (An experiment usually lasts less than a minute).

5. Connect a suitable power supply to the solenoid system. The solenoids require a nominal operating voltage of 12 volts and if all are to be energized, approximately 20 amperes are required. To minimize the heating in the solenoid coils, the minimum voltage should be used. Approximately 10 volts is usually sufficient. Assurance that the voltage is adequate and that the solenoids are working properly may be obtained by doing a "dry run", i.e. operating the equipment with the battery not connected. All activated solenoids should close more or less simultaneously as soon as the discharge button is depressed. Any audible lag in the clicking of the contacts should be investigated and if necessary the supply voltage should be increased.

In experiments involving lengthy solenoid operating times (i.e. beyond 30 seconds), solenoid heating may be minimized by reducing the supply voltage after the solenoids are activated. A suitable "holding voltage" should be determined experimentally before starting the run.

6. Ensure that the cam system is accurately in the zero position by doing a "dry run" with the battery not connected.

7. Plug in the connector to the battery to be tested.

8. Actuate the desired standby buttons and set the corresponding manual switches to their armed positions.

9. Start all recording equipment and ensure that pens are writing satisfactorily.

10. Operate the discharge button. Be ready to operate the emergency stop button should it become necessary.

11. In complex experiments it is useful to prepare a check list of all actions and observations required, before carrying out the experiment. It is sometimes advisable to have an assistant call out the items as the actions are required. This was found necessary in an experiment that involved two simulated engine starts a specified number of minutes apart, with an intervening and a subsequent high rate recharge using auxiliary equipment.

TIMING ADJUSTMENTS

Familiarity with the sections on control circuits and operating instructions is assumed.

Automatic timing is provided by a cam system located in the control circuit and accessible through the open rear of the cabinet. The cams are mounted on a common shaft which is rotated by a synchronous 117Vac motor. In an automatic sequence the motor is switched on at the start of the sequence when the discharge button is operated. It rotates the cam shaft one complete revolution and then stops. During the revolution, which requires 50 seconds to complete, the cams operate microswitches which indirectly control the

solenoid switches in the desired manner.

The microswitches are provided with double throw switches, hence the cam may open the circuit by either depressing or releasing the microswitch lever depending on how the switch is wired. In general the mode in which the cam must depress the lever to open the switch is used if the desired time interval exceeds one half of the cam revolution time. In the instructions below, the cam state which permits the corresponding solenoid switch to be closed is referred to as the "on" state, regardless of the details in the microswitch operation. Similarly, if the solenoid switch cannot be closed, the cam is said to be in the "off" state.

Each cam is made up of two segments. When the appropriate set screws are loosened, it is possible to set the segments in position on the shaft to give the desired operation.

In the description here, the cams are numbered from left to right as viewed from the rear of the cabinet.

When the cam shaft is in the zero position all cams which control discharge circuits are in "on" positions (but the corresponding relays are unenergized until the discharge button is operated). After the appropriate respective run times, cams de-energize the corresponding circuits by going to their "off" state.

Cam #9 determines the zero position of the system by stopping the synchronous motor at the end of the complete cycle. Its position is arbitrary. All other cams are adjusted with respect to this one, but all other cams must complete their cycles, i.e. return to their "on" states, before the motor stops.

Cam #10 permits the initiation of each battery discharge when the discharge button is operated. This action energizes relay KK10 which (a) locks itself in; (b) starts the cam motor; and (c) closes the circuit to energize the heavy duty relay KK12. The latter applies power to the solenoids. At the conclusion of the final step in the discharge cam #10 opens the locked circuit to relay KK10 which then opens and de-energizes relay KK12. In view of the above, cam #10 should be adjusted first, to give the desired timing for the precise ending of the final step in the discharge period. A method for accurately checking the timing is described below.

Cams #1 to #8 inclusive should then be adjusted so that they return to their "on" positions after cam #10 goes "off" but before the motor stops at the end of the cycle. This should be rechecked for each cam after subsequent adjustments. Each of the #1 to #8 cams are then adjusted to reach their respective "off" positions at the desired time intervals.

Since cam #10 stops the discharge when it reaches its "off" position regardless of other cam positions, those cams from #1 to #8 which are intended to end the final step need not be accurately adjusted. They may be merely set to go "off" shortly after cam #10 goes "off".

It is difficult to accurately determine where any given cam should

be set to give the precise timing desired. A convenient method, therefore, is to set it approximately and then do a timing measurement. This is followed by a minor adjustment and a retest, etc., until the desired precision is attained.

Precise timing measurements may be made with the aid of a suitable strip chart recorder operated at, say, a chart speed of 10 division per second. The recorder may be connected across a suitable instrument shunt which is placed in series with the power supply which operates the solenoid switches. The resulting stepped trace clearly indicates the timing produced by the cam system.

An alternative method is to use the "Time AC Output" (see "Data Output" section) to time individual steps if a suitable 117Vac timer is available. (Timer must stop instantly when power is removed).

APPENDIX I

EQUIVALENT RESISTANCES

Nominal equivalent resistance values for various resistor combinations are given below. Actual resistances tend to be slightly higher than the nominal values due to resistances of the interconnections and of the solenoid switches. It should be noted that the latter resistances cannot be reliably measured in the "dry contact" condition and may not repeat perfectly from closure to closure. However, the total resistance tends to vary by less than one milliohm and can be calculated accurately from the current and voltage measurements observed in each experiment.

Overload precautions given in the section on "Operation of Resistor Bank" should be observed if unusual resistor combinations are used.

<u>Resistors Used</u>	<u>Nominal Equivalent Resistance</u>			
	<u>mode 1</u>	<u>mode 2</u>	<u>mode 3</u>	<u>mode 4</u>
1	100 mΩ	106 mΩ	50 mΩ	56 mΩ
1 and 2	50	56	25	31
1 to 3 inclusive	33	40	17	23
1 to 4 inclusive	20	26	13	19
1 to 5 inclusive	14	21	10	16
1 to 6 inclusive	9	15	7	13
1 to 7 inclusive	5	12	5	11
1 to 8 inclusive	3	-	3	-

PRECEDING PAGE, BLANK, NOT FILMED

APPENDIX II

CURRENT-TIME CURVE SIMULATION

Procedure in arriving at the desired simulation of a specified aircraft engine starting profile is illustrated below.

The current versus time profile for an actual engine start is shown by the smooth curve in Figure 6. A stepped equivalent is superimposed on this curve. The current magnitude for each step is tabulated below. It is assumed that the internal resistance of the battery to be investigated is approximately 15 milliohms and that its initial electromotive force is approximately 24 volts. The required load resistance to give each current step is calculated.

<u>Time</u>	<u>Current</u>	<u>24V/Current</u>	<u>Less Battery Resistance of 15mΩ</u>	<u>Obtained by Use of (Mode 2)</u>
2 sec.	890A	27m Ω	12m Ω	R1-R7 inclusive
2	800	30	15	R1-R6
9	665	36	21	R1-R5
3	572	42	27	R1-R4 (approximate)
4	435	55	40	R1-R3

From the above, set cams so R7 switches out at the end of 2 seconds, R6 at 4 seconds, R5 at 13 seconds, R4 at 16 seconds and R1-R3 (via cam #10) at the end of 20 seconds.

TABLE I

Connector Wiring

<u>Connector Pin</u>	<u>Connector Item</u>	<u>Wire Color</u>
A	Solenoid 1 open light	Red
B	" 2 " "	"
C	" 3 " "	"
D	" 4 " "	"
E	" 5 " "	"
F	" 6 " "	"
G	" 8" " "	"
H	Solenoid Coil 8" switch	Black
J	Current Shunt (-)	Orange
K	Unused	
L	"	
M	Solenoid switches return	Brown
N	"	"
P	"	"
R	"	"
S	Current Shunt (+)	Green
T		
U	Battery Voltage (+)	Red
V	" " (-)	White
W	Solenoid 7' Open Light	Red
X	" 7" " "	"
Y	" 8' " "	"
Z	Solenoid Coil 8' switch	Black
a	" " 7" "	"
b	" " 7' "	"
c	" " 6 "	"
d	" " 5 "	"
e	Solenoid Open Light return	"
f	Solenoid Coil 1 switch	"
g	" " 2 "	"
h	" " 3 "	"
j	" " 4 "	"

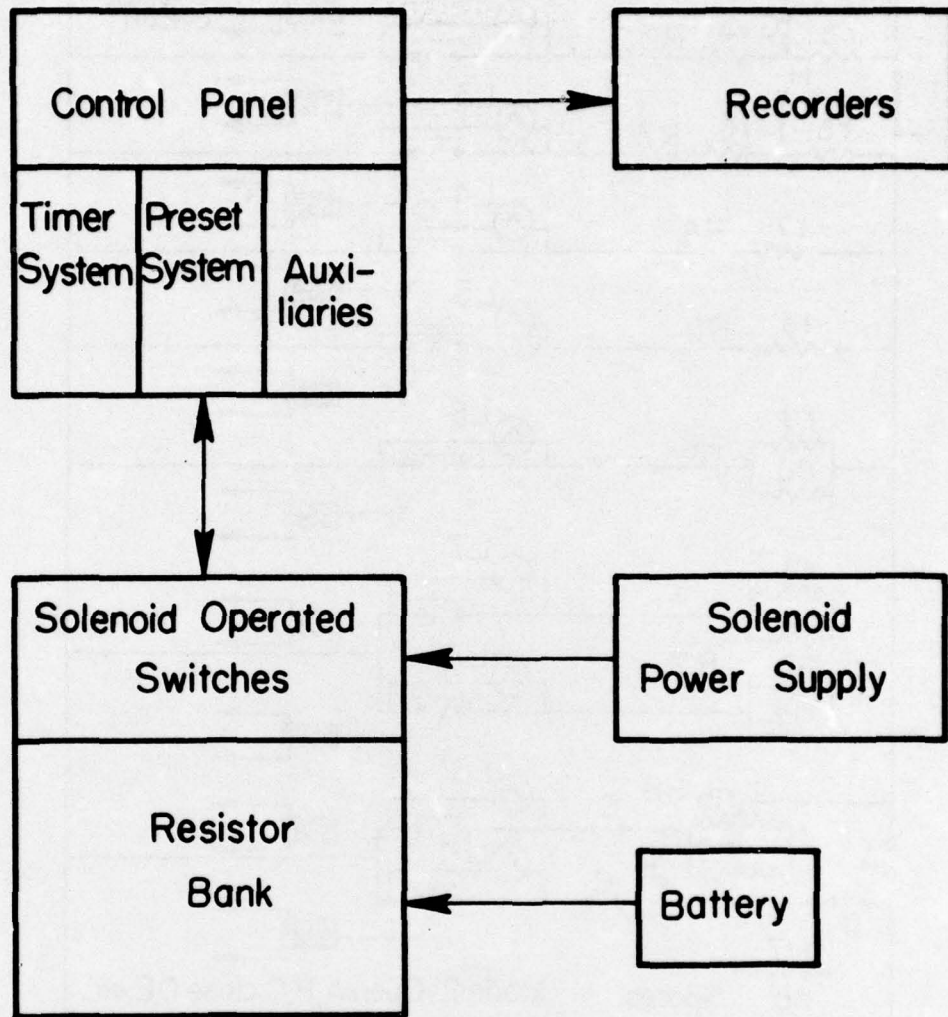

Fig. 1: System Block Diagram

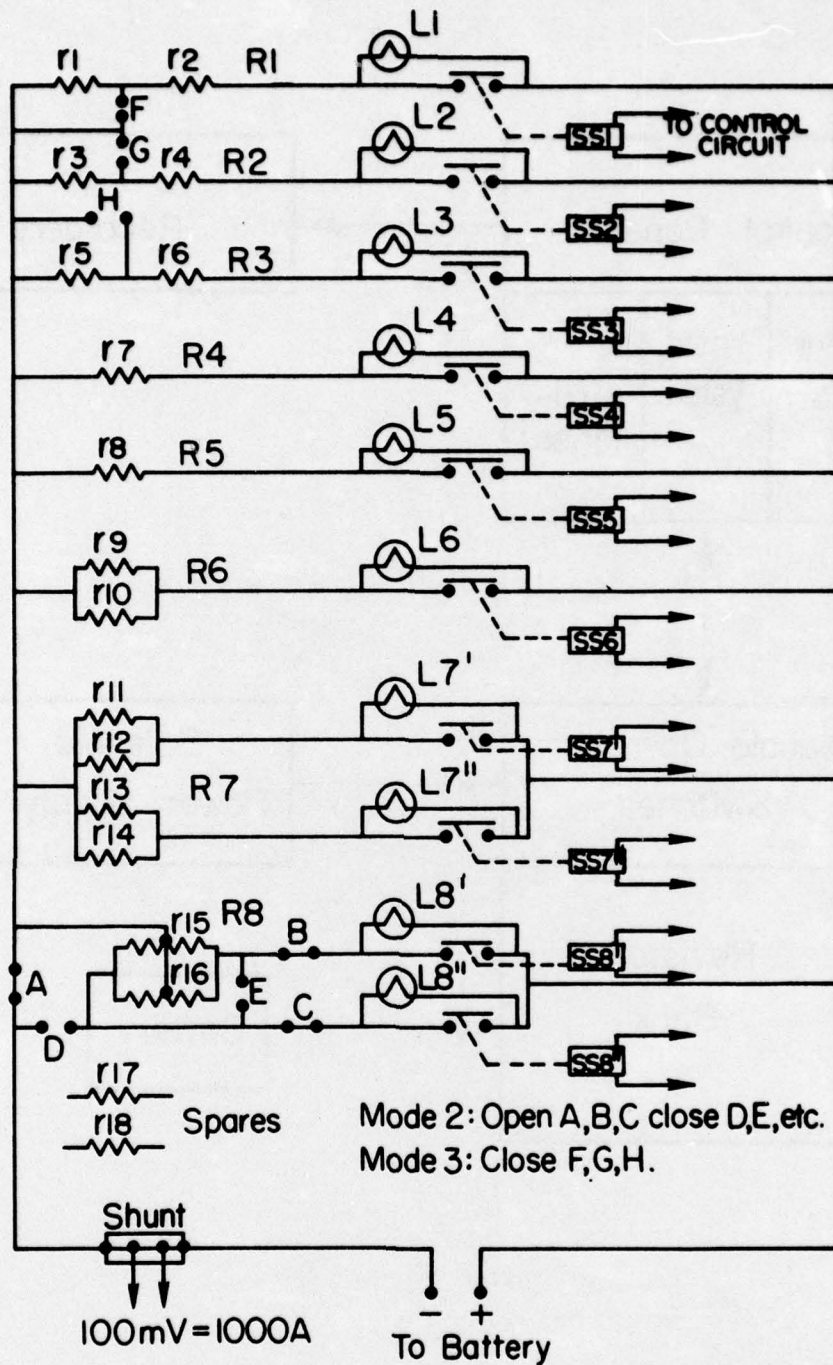

Fig. 2: Resistor Bank

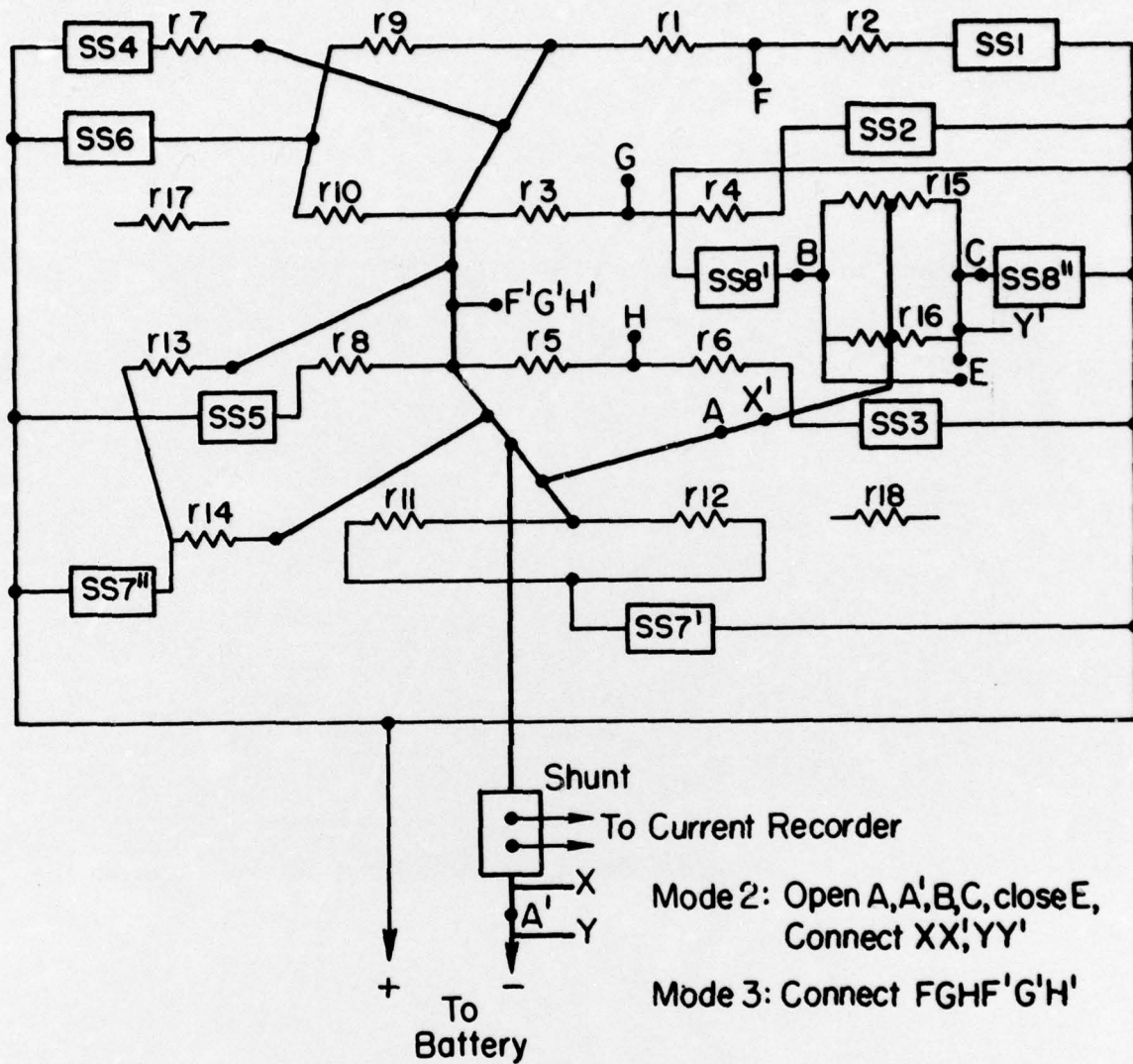

Fig. 3: Resistor Location Diagram



Fig. 4: Control Panel

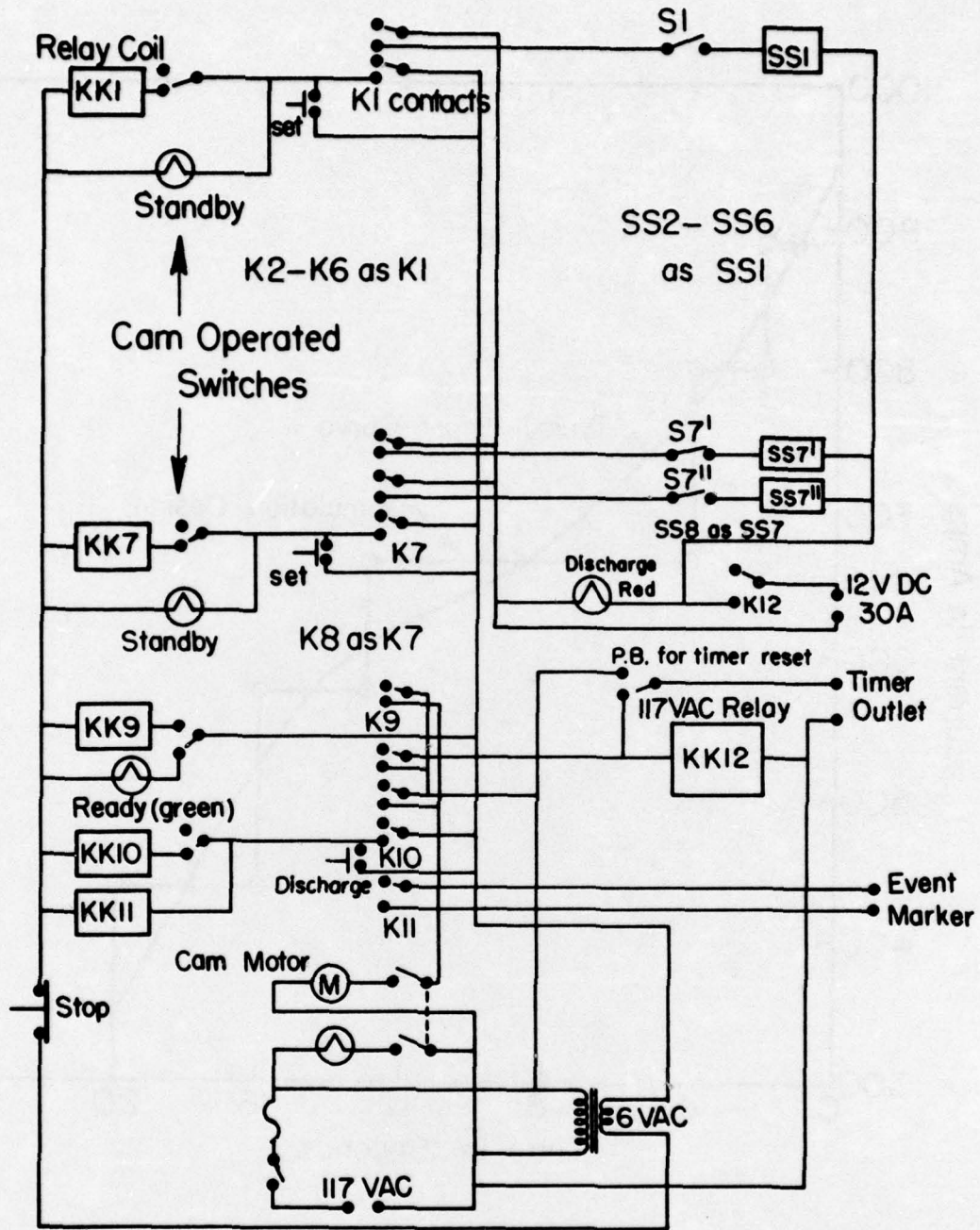

Fig. 5: Control Circuit

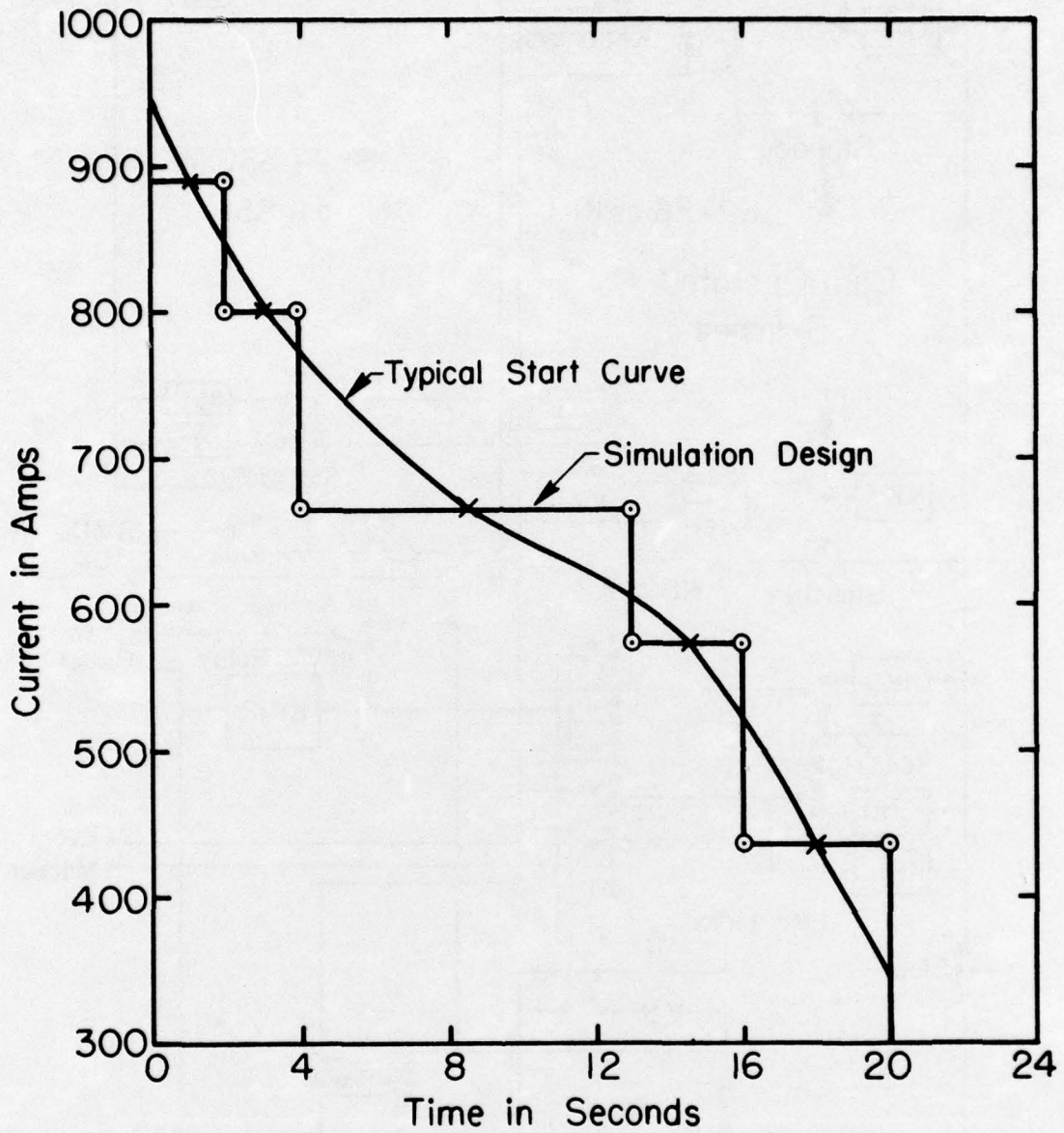

Fig. 6: Engine Start Curve

UNCLASSIFIED

Security Classification

DOCUMENT CONTROL DATA - R & D

(Security classification of title, body of abstract and indexing annotation must be entered when the overall document is classified)

1. ORIGINATING ACTIVITY Defence Research Establishment Ottawa ✓ National Defence Headquarters Ottawa, Ontario, Canada K1A 0Z4		2a. DOCUMENT SECURITY CLASSIFICATION UNCLASSIFIED	
		2b. GROUP N/A	
3. DOCUMENT TITLE NICKEL/CADMIUM AIRCRAFT BATTERIES: HIGH RATE DISCHARGE EQUIPMENT (U)			
4. DESCRIPTIVE NOTES (Type of report and inclusive dates) TECHNICAL NOTE 76-22			
5. AUTHOR(S) (Last name, first name, middle initial) FELDMAN, Keiva, HAINES, Ronald L., and LEPAGE, William A. (Capt.)			
6. DOCUMENT DATE AUGUST 1976		7a. TOTAL NO. OF PAGES 20	7b. NO. OF REFS.
8a. PROJECT OR GRANT NO. 54-03-07		9a. ORIGINATOR'S DOCUMENT NUMBER(S) ✓ DREO TECHNICAL NOTE NO. 76-22	
8b. CONTRACT NO.		9b. OTHER DOCUMENT NO.(S) (Any other numbers that may be required this document)	
10. DISTRIBUTION STATEMENT UNLIMITED DISTRIBUTION			
11. SUPPLEMENTARY NOTES		12. SPONSORING ACTIVITY	
13. ABSTRACT Factors that are not of major significance in low rate battery discharges become quite important when a battery is used to crank an aircraft turbine engine. Apparatus was designed and built to facilitate the study of nickel/cadmium aircraft batteries when used in this and other high rate applications. Maximum discharge rates of 1000 amperes or more are possible with 24-volt batteries. Load configurations may be readily modified. Discharge profiles are simulated by use of fixed load steps which may be timed either automatically or manually. This document describes the equipment and gives instructions for its use.			

UNCLASSIFIED

KEY WORDS

NICKEL/CADMIUM BATTERIES

HIGH RATE DISCHARGE EQUIPMENT

ENGINE START SIMULATION

AIRCRAFT BATTERIES

BATTERY TEST EQUIPMENT

INSTRUCTIONS

1. **ORIGINATING ACTIVITY**: Enter the name and address of the organization issuing the document.
- 2a. **DOCUMENT SECURITY CLASSIFICATION**: Enter the overall security classification of the document including special warning terms whenever applicable.
- 2b. **GROUP**: Enter security reclassification group number. The three groups are defined in Appendix 'M' of the DRB Security Regulations.
3. **DOCUMENT TITLE**: Enter the complete document title in all capital letters. Titles in all cases should be unclassified. If a sufficiently descriptive title cannot be selected without classification, show title classification with the usual one-capital-letter abbreviation in parentheses immediately following the title.
4. **DESCRIPTIVE NOTES**: Enter the category of document, e.g. technical report, technical note or technical letter. If appropriate, enter the type of document, e.g. interim, progress, summary, annual or final. Give the inclusive dates when a specific reporting period is covered.
5. **AUTHOR(S)**: Enter the name(s) of author(s) as shown on or in the document. Enter last name, first name, middle initial. If military, show rank. The name of the principal author is an absolute minimum requirement.
6. **DOCUMENT DATE**: Enter the date (month, year) of Establishment approval for publication of the document.
- 7a. **TOTAL NUMBER OF PAGES**: The total page count should follow normal pagination procedures, i.e., enter the number of pages containing information.
- 7b. **NUMBER OF REFERENCES**: Enter the total number of references cited in the document.
- 8a. **PROJECT OR GRANT NUMBER**: If appropriate, enter the applicable research and development project or grant number under which the document was written.
- 8b. **CONTRACT NUMBER**: If appropriate, enter the applicable number under which the document was written.
- 9a. **ORIGINATOR'S DOCUMENT NUMBER(S)**: Enter the official document number by which the document will be identified and controlled by the originating activity. This number must be unique to this document.
- 9b. **OTHER DOCUMENT NUMBER(S)**: If the document has been assigned any other document numbers (either by the originator or by the sponsor), also enter this number(s).
10. **DISTRIBUTION STATEMENT**: Enter any limitations on further dissemination of the document, other than those imposed by security classification, using standard statements such as:
 - (1) "Qualified requesters may obtain copies of this document from their defence documentation center."
 - (2) "Announcement and dissemination of this document is not authorized without prior approval from originating activity."
11. **SUPPLEMENTARY NOTES**: Use for additional explanatory notes.
12. **SPONSORING ACTIVITY**: Enter the name of the departmental project office or laboratory sponsoring the research and development. Include address.
13. **ABSTRACT**: Enter an abstract giving a brief and factual summary of the document, even though it may also appear elsewhere in the body of the document itself. It is highly desirable that the abstract of classified documents be unclassified. Each paragraph of the abstract shall end with an indication of the security classification of the information in the paragraph (unless the document itself is unclassified) represented as (TS), (S), (C), (R), or (U).

The length of the abstract should be limited to 20 single-spaced standard typewritten lines. 7 1/2 inches long.
14. **KEY WORDS**: Key words are technically meaningful terms or short phrases that characterize a document and could be helpful in cataloging the document. Key words should be selected so that no security classification is required. Identifiers, such as equipment model designation, trade name, military project code name, geographic location, may be used as key words but will be followed by an indication of technical context.