

AD-A031 901

GRUMMAN AEROSPACE CORP BETHPAGE N Y  
SLIDING-SEAL ELECTRON-BEAM WELDING. (U)  
JAN 76 H P ELLISON, R H WITT

F/G 13/8

UNCLASSIFIED

AFML-TR-76-3

F33615-73-C-5030

NL

1 OF 3  
AD A031901  
DATE

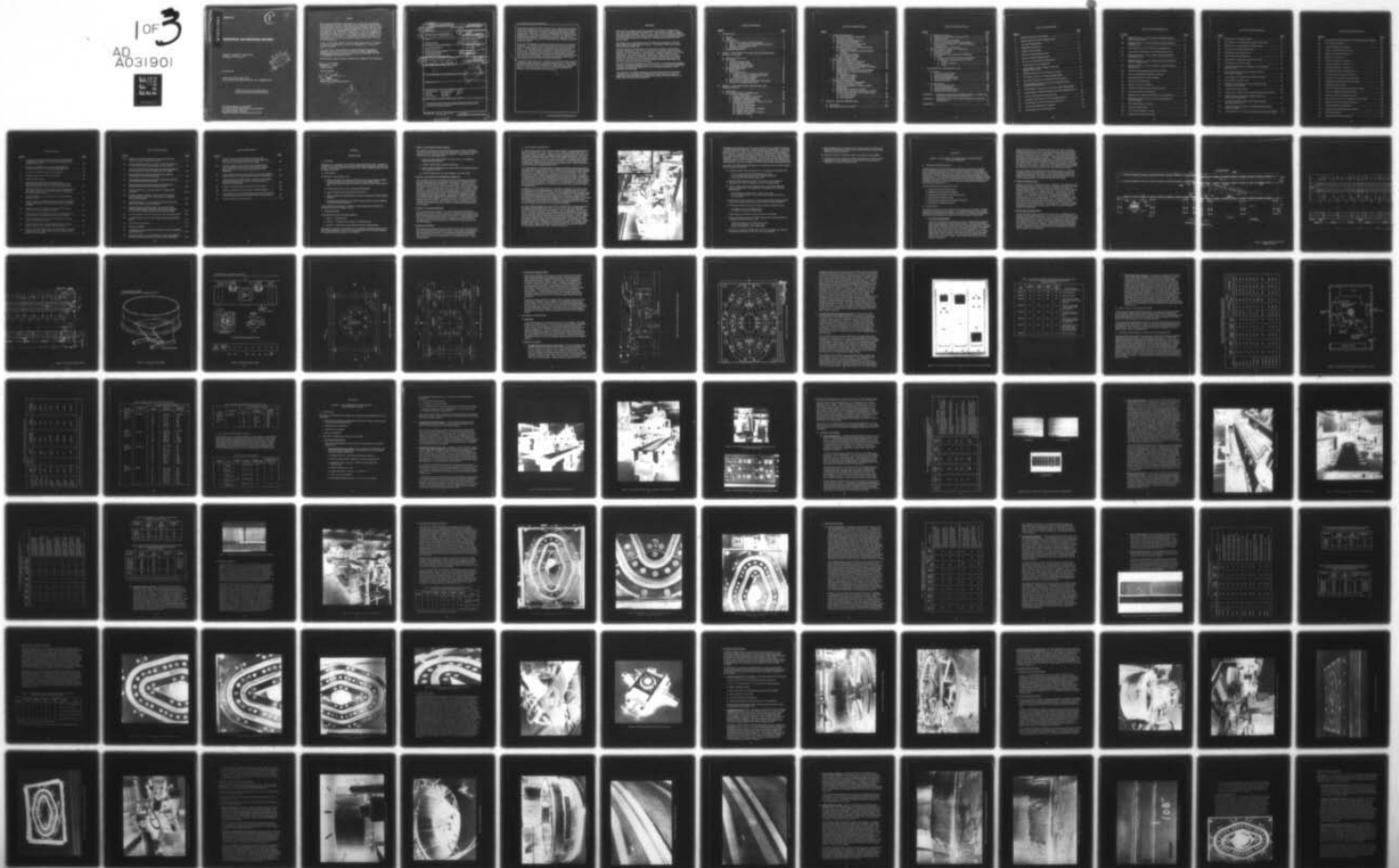

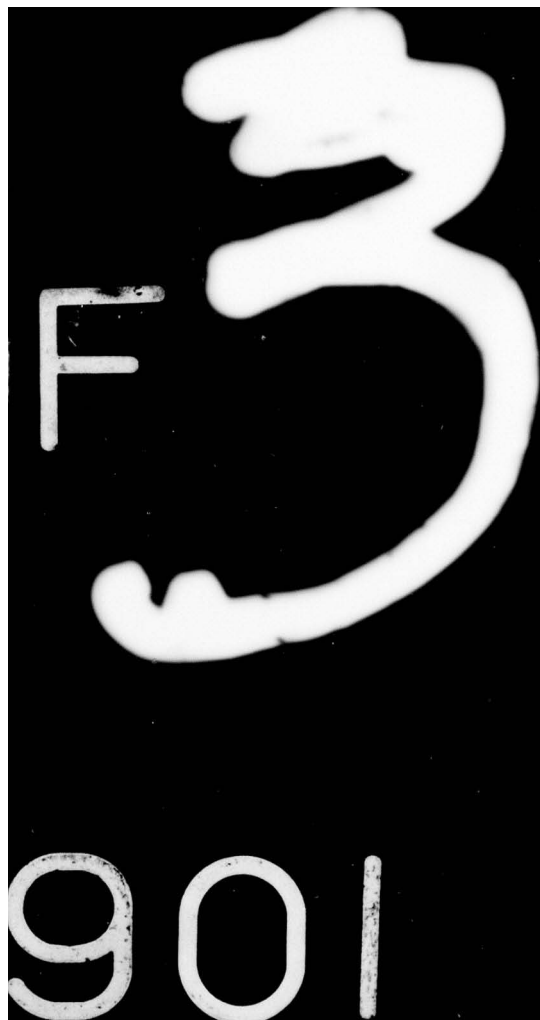

ADA031901

AFML-TR-76-3

①

②

# SLIDING-SEAL ELECTRON-BEAM WELDING

GRUMMAN AEROSPACE CORPORATION  
BETHPAGE, NEW YORK 11714

DDC  
NOV 11 1976  
R  
C

JANUARY 1976

TECHNICAL REPORT AFML-TR-76-3  
FINAL REPORT FOR PERIOD FEBRUARY 1973 - DECEMBER 1975

Approved for public release; distribution unlimited

AIR FORCE MATERIALS LABORATORY  
AIR FORCE WRIGHT AERONAUTICAL LABORATORIES  
AIR FORCE SYSTEMS COMMAND  
WRIGHT-PATTERSON AIR FORCE BASE, OHIO 45433

NOTICE

When Government drawings, specifications, or other data are used for any purpose other than in connection with a definitely related Government procurement operation, the United States Government thereby incurs no responsibility for any obligation whatsoever; and the fact that the Government may have formulated, furnished, or in any way supplied the said drawings, specifications, or other data, is not to be regarded by implication or other wise as in any manner licensing the holder or any other person or corporation, or conveying any rights or permission to manufacture, use, or sell any patented invention that may in any way be related thereto.

Copies of this report should not be returned unless return is required by security considerations, contractual obligations, or notice on a specific document.

This final report was submitted by Grumman Aerospace Corporation, Bethpage, New York, under Contract F33615-73-C-5030, Manufacturing Methods Project 846-3, Sliding Seal Electron Beam Welding. Mr. Fred R. Miller was the laboratory monitor.

This technical report has been reviewed and is approved for publication.

*Frederick R. Miller*  
FREDERICK R. MILLER  
Project Monitor

FOR THE DIRECTOR

*H. A. Johnson*  
H. A. JOHNSON  
Chief, Metals Branch  
Manufacturing Technology Division

AIR FORCE - 24 SEPTEMBER 76 - 150

Accession for  Wire Section   
 Ball Section

HIS  
DUG  
UNASSIGNED  
JUSTIFICATION

BY DISTRIBUTION/AVAILABILITY CODES  
Dist.  ANNUAL REV. OF SERIAL

PA

UNCLASSIFIED

SECURITY CLASSIFICATION OF THIS PAGE (When Data Entered)

| 19 REPORT DOCUMENTATION PAGE   |   | READ INSTRUCTIONS<br>BEFORE COMPLETING FORM                      |
|--|---|--|
| 1. REPORT NUMBER<br>AFML TR-76-3   | 2. GOVT ACCESSION NO.   | 3. RECIPIENT'S CATALOG NUMBER                                    |
| 4. TITLE (and Subtitle)<br>SLIDING-SEAL ELECTRON-BEAM WELDING  | 5. TYPE OF REPORT & PERIOD COVERED<br>Final Report<br>February 1973 - December 1975 | 6. PERFORMING ORG. REPORT NUMBER                                 |
| 7. AUTHOR(s)<br>H.P. Ellison and R.H. Witt   | 8. CONTRACT OR GRANT NUMBER(s)<br>F33615-73-C-5030 new                              |  |
| 9. PERFORMING ORGANIZATION NAME AND ADDRESS<br>Grumman Aerospace Corporation<br>Bethpage, New York 11714   | 10. PROGRAM ELEMENT, PROJECT, TASK AREA & WORK UNIT NUMBERS<br>Project No. 846-3    |  |
| 11. CONTROLLING OFFICE NAME AND ADDRESS<br>Air Force Materials Laboratories<br>Air Force Systems Command<br>Wright-Patterson Air Force Base, Ohio 45433  | 12. REPORT DATE<br>January 1976   |  |
| 14. MONITORING AGENCY NAME & ADDRESS (if different from Controlling Office)<br>Harold P. Ellison<br>Robert H. Witt   | 13. NUMBER OF PAGES<br>204  | 15. SECURITY CLASS. (of this report)<br>Unclassified (12) 202 p. |
| 16. DISTRIBUTION STATEMENT (of this Report)  | 15a. DECLASSIFICATION/DEREGISTRATION SCHEDULE                                       |  |
| 17. DISTRIBUTION STATEMENT (of the abstract entered in Block 20, if different from Report)   |   |  |
| 18. SUPPLEMENTARY NOTES  |   |  |
| 19. KEY WORDS (Continue on reverse side if necessary and identify by block number)   |   |  |
| Electron-Beam Welding  | Special Shapes Welding  | Aluminum   |
| Sliding Seal   | Flat Plate Welding  | Titanium   |
| Weld Tooling   | Seal Life/Wear  | Steel  |
| Cylindrical Welding  | Preheat Welding   |  |
| 20. ABSTRACT (Continue on reverse side if necessary and identify by block number)  |   |  |
| <p>The results of a sequential, three-phase program beginning with the design, fabrication and evaluation of four welding fixtures (flat plate, cylindrical, special shapes and preheat) and ending with a process demonstration on F-14 wing beams are reported.</p> <p style="text-align: right;">→ next page. →</p> |   |  |

DD FORM 1 JAN 73 1473

EDITION OF 1 NOV 65 IS OBSOLETE  
S/N 0102-014-6601

UNCLASSIFIED

SECURITY CLASSIFICATION OF THIS PAGE (When Data Entered)

388847

JB

Design layouts and detailed prints were drawn for four welding fixtures required for long flat plate welding (over 10 feet in length), cylinder welding (12-foot diameter), complex shape welding (Tees) and welding of high strength alloy steels in a special preheat vacuum chamber box. Fixtures were fabricated and installed in the SSEB welding facility. Weldments were made on the weld fixtures and evaluated by visual and nondestructive inspection using radiography, ultrasonic, dye-penetrant and magnetic particle inspection. Limited tensile testing was conducted on the aluminum and titanium flat plate weldments and HY130 and D6AC steel weldments made in the preheat steel fixture.

Twelve-foot-long aluminum and titanium butt welds were fabricated on the flat plate weld fixture. A comprehensive seal life/wear study was conducted for aluminum and titanium plate by making bead-on-plate and butt welds on the flat plate welding fixture. A 12-foot-diameter cylinder was fabricated and successfully welded utilizing a curved SSEB head plate and inflatable "d"-ring seals for vacuum sealing of the cylinder. Acceptable crack-free weldments were fabricated in HY130 and D6AC steel alloys using the preheat weld fixture which preheated the materials to 200°F and 350°F prior to welding. Tee shapes in aluminum and titanium alloys were vacuum sealed in the special shapes weld fixture using injection molded silicone rubber seals and SSEB welded through a slot in the cover plate.

A selected aerospace structure (F-14 wing beam) was successfully SSEB welded, thus demonstrating equipment capability to fabricate production parts. Tensile, fatigue and fracture toughness results are presented for a welded wing beam. Recommendations for further improvement or refinement of the SSEB welding equipment are included. A recommended industry equipment and a welding specification for aluminum, titanium and steel alloys are also included.

## FOREWORD

This report was prepared by Grumman Aerospace Corporation, Bethpage, New York 11714, under USAF Contract F33615-73-C-5030, Project No. 846-3, "Sliding-Seal Electron-Beam Welding," Task No. 846-3. The work was administered under the technical direction of Mr. Fred Miller (AFML/LTM), Air Force Materials Laboratory, Air Force Wright Aeronautical Laboratories, Manufacturing Technology Division, Metals Branch.

This report covers work conducted from 26 February 1973 through 30 June 1975, and is submitted in fulfillment of the contract. The technical report was released by the authors in October 1975.

The work reported was performed by personnel from Grumman's Materials and Processes Department. The program was directed by Harold P. Ellison, Project Engineer, and Mr. Robert Witt, Project Manager, Advanced Materials and Processes Development. Others assisting on the program were Messrs. Robert Messler, Joseph Daley, Salvatore Stracquadini, Vincent Sgro, William Peterson, Charles Johnson and Carmine Vizzi of the Advanced Materials and Processes Development Department, Mr. Robert Dooley of Special Tooling and Methods Department, and Facilities Engineering Department personnel.

This project has been accomplished as a part of the Air Force Manufacturing Methods Program, the primary objective of which is to develop on a timely basis manufacturing processes, techniques and equipment for use in economical production of USAF materials and components.

Your comments are solicited regarding the potential utilization of the information contained herein as applied to your present and/or future production programs. Suggestions concerning additional manufacturing methods development required on this or other subjects will be appreciated.

## TABLE OF CONTENTS

| <u>Section</u>   | <u>Page</u> |
|--|-------------|
| I INTRODUCTION .....   | 1           |
| A. Purpose .....   | 1           |
| B. Objectives .....  | 1           |
| C. Program Scope .....   | 1           |
| 1. Phase I - Tool Design for SSEB Flexibility .....                                      | 2           |
| 2. Phase II - Tool Fabrication, Installation and Check-Out .....                         | 2           |
| 3. Phase III - Process Demonstration .....   | 2           |
| 4. Specification Definition .....  | 2           |
| D. Background Information .....  | 3           |
| II PHASE I - TOOL DESIGN FOR SLIDING-SEAL ELECTRON-BEAM<br>WELDING FLEXIBILITY .....     | 7           |
| A. Approach and Work Areas .....   | 7           |
| B. Tool Design .....   | 7           |
| 1. Flat Plate Welding Fixture .....  | 7           |
| 2. Cylindrical Welding Fixture .....   | 8           |
| 3. Special Shapes Welding Fixture .....  | 8           |
| 4. Preheat Steel Welding Fixture .....   | 15          |
| C. Equipment Modifications .....   | 15          |
| 1. SSEB Head .....   | 15          |
| 2. Special Control Units .....   | 15          |
| a. Constant-Current and Overload Control Units .....                                     | 15          |
| b. Proximity and Seam Tracking Control Units .....                                       | 18          |
| c. Weld Current Slope Techniques .....   | 21          |
| D. Area Layout for Welding Fixtures .....  | 21          |
| E. Material Procurement and Weld Coupon Fabrication .....                                | 21          |
| F. Seal Life/Wear Evaluation Planning .....  | 26          |
| III PHASE II - TOOL FABRICATION, INSTALLATION AND<br>WELDING PROGRAM .....               | 27          |
| A. Work Areas .....  | 27          |
| B. Weld Tool Fabrication and Welding Tasks .....   | 27          |
| 1. Flat Plate Welding Fixture .....  | 27          |
| a. Material and Hardware Procurement .....   | 27          |
| b. Welding and Machining of Fixture .....  | 28          |
| c. Installation in SSEB Welding Area .....   | 28          |
| d. Check-Out and Verification of Tooling Concept for<br>Flat Plate Welding Fixture ..... | 32          |
| (1) Aluminum Plate Welding .....   | 32          |
| (2) Weld Seam Alignment .....  | 40          |
| (3) Aluminum Seal Life Wear Evaluation .....   | 42          |
| (4) Titanium Plate Welding .....   | 46          |
| (5) Titanium Seal Life Wear Evaluation .....   | 52          |
| (6) Filler Wire Addition .....   | 56          |

TABLE OF CONTENTS (Con't)

| <u>Section</u>   | <u>Page</u> |
|--|-------------|
| 2. Cylinder Welding Fixture . . . . .  | 59          |
| a. Material and Hardware Procurement . . . . .   | 59          |
| b. Fabrication of Fixture . . . . .  | 59          |
| c. Installation in SSEB Welding Area . . . . .   | 62          |
| d. Equipment Head Modification . . . . .   | 62          |
| (1) Fabrication of Curved Head Plate . . . . .   | 62          |
| (2) Vacuum Sealing on Cylinder . . . . .   | 62          |
| e. Welding of Cylinder to Verify Tooling Concept . . . . .   | 68          |
| (1) Cylinder Fabrication . . . . .   | 68          |
| (2) Installation of Inflatable Seals and Cylinder<br>on Fixture . . . . .  | 68          |
| (3) GTA Seal Pass Welding . . . . .  | 74          |
| (4) SSEB Welding of Cylinder . . . . .   | 74          |
| f. Cylinder Welding Evaluation . . . . .   | 78          |
| 3. Special Shapes Welding Fixture . . . . .  | 79          |
| a. Material and Hardware Procurement . . . . .   | 79          |
| b. Welding and Machining of Fixture . . . . .  | 79          |
| c. Setup on Weld Table in SSEB Welding Room . . . . .  | 79          |
| d. Fabrication of Aluminum and Titanium Tee Shapes . . . . .   | 82          |
| e. Molding of Special-Shape Seals . . . . .  | 82          |
| f. Welding Tasks Performed on the Special Shapes<br>Welding Fixture to Check-Out and Verify the<br>Tooling Concept . . . . . | 82          |
| (1) Aluminum Tee Shapes . . . . .  | 86          |
| (2) Titanium Tee Shapes . . . . .  | 89          |
| g. Weld Fixture Evaluation . . . . .   | 89          |
| 4. Preheat Steel Welding Fixture . . . . .   | 89          |
| a. Material and Hardware Procurement . . . . .   | 89          |
| b. Welding and Machining of Fixture . . . . .  | 89          |
| c. Setup and Instrumentation of Fixture in SSEB<br>Welding Room . . . . .  | 91          |
| d. Heating Studies Performed in Fixture . . . . .  | 91          |
| e. Welding Tasks Performed in Preheat Steel Welding<br>Fixture to Check-Out and Verify Tooling Concept . . . . .             | 91          |
| (1) HY 130 Steel Welding . . . . .   | 95          |
| (2) D6AC Steel Welding . . . . .   | 95          |
| (3) Weld Evaluation . . . . .  | 99          |
| <br>IV PHASE III - PROCESS DEMONSTRATION . . . . .   | <br>105     |
| A. Work Areas . . . . .  | 105         |
| B. Component Selection and Planning . . . . .  | 105         |

TABLE OF CONTENTS (Con't)

| <u>Section</u>  | <u>Page</u> |
|---|-------------|
| C. F-14 Wing Beam Welding .....   | 106         |
| 1. Selection and Description of Component Part .....  | 106         |
| 2. Welding Program .....  | 106         |
| 3. Fixture and Vacuum/Box Design .....  | 110         |
| 4. Set Up of Vacuum Box in SSEB Welding Facility .....  | 114         |
| 5. Check-Out and Verification of Large Scale SSEB Slot<br>Welding Concept .....   | 114         |
| 6. Test Welding of F-14 Wing Beams .....  | 117         |
| D. NDI and Mechanical Testing of F-14 Wing Beam .....   | 117         |
| 1. Radiographic Inspection .....  | 120         |
| 2. Ultrasonic Inspection .....  | 120         |
| 3. Determination of Room Temperature Mechanical<br>Properties .....   | 125         |
| a. Layout of Test Specimen Location on Wing Beam .....  | 125         |
| b. Test Specimen Configurations and Test Data .....   | 125         |
| 1. Tension .....  | 125         |
| 2. Fracture Toughness .....   | 125         |
| 3. Fatigue .....  | 134         |
| V CONCLUSIONS AND RECOMMENDATIONS .....   | 143         |
| A. Conclusions .....  | 143         |
| 1. Flat Plate Welding Fixture .....   | 143         |
| 2. Cylinder Welding Fixture .....   | 145         |
| 3. Special Shapes Welding Fixture .....   | 146         |
| 4. Preheat Steel Welding Fixture .....  | 146         |
| 5. Wing Beam Welding .....  | 148         |
| B. Recommendations .....  | 149         |
| 1. Flat Plate Welding Fixture .....   | 149         |
| 2. Cylinder Welding Fixture .....   | 150         |
| 3. Special Shapes Welding Fixture .....   | 150         |
| 4. Preheat Steel Welding Fixture .....  | 150         |
| APPENDIX I - Sliding-Seal Electron Beam Welding of Aluminum, Titanium and<br>Steel Alloys; Requirements Specification for ..... | 151         |
| APPENDIX II - Sliding-Seal Electron Beam Welder; Equipment and Application<br>Specification for .....                           | 171         |
| REFERENCES .....  | 189         |

## LIST OF ILLUSTRATIONS

| <u>Figures</u>  | <u>Page</u> |
|---|-------------|
| 1. Sliding-Seal Electron-Beam Welder . . . . .  | 4           |
| 2. Support Table for Flat Plate Welding Fixture . . . . .   | 9           |
| 3. Flat Plate Welding Fixture. . . . .  | 10          |
| 4. Cylindrical Welding Setup . . . . .  | 11          |
| 5. Cylinder Vacuum Sealing . . . . .  | 12          |
| 6. End View of Special Shapes Fixture . . . . .   | 13          |
| 7. Side View of Special Shapes Fixture . . . . .  | 14          |
| 8. End View of Preheat Steel Welding Fixture . . . . .  | 16          |
| 9. Curved Plate for Head Modification . . . . .   | 17          |
| 10. Control Panel for Beam Constant-Current and<br>Overload Control Units . . . . .               | 19          |
| 11. Sliding-Seal Electron-Beam Welding Area Layout . . . . .                                      | 23          |
| 12. ICF Support Tables for Flat Plate Welding Fixture . . . . .                                   | 29          |
| 13. Flat Plate Welding Fixture Mounted on Table Assembly . . . . .                                | 30          |
| 14. Two-Horsepower Motor and Gear Box Arrangement for the<br>Flat Plate Welding Fixture . . . . . | 31          |
| 15. Control Station - Junction Box for the Flat Plate Welding Fixture . . .                       | 31          |
| 16. Views of Bead-on-Plate Weld Made on Flat Plate Welding Fixture . . .                          | 34          |
| 17. 12-Foot-Long Aluminum Butt Weld Setup . . . . .   | 36          |
| 18. Aluminum Cover Plate on Flat Plate Welding Fixture . . . . .                                  | 37          |
| 19. Macro-Section of 2014-T651 Aluminum Butt Weld . . . . .                                       | 40          |
| 20. Laser Optical Measuring Arrangement . . . . .   | 41          |
| 21. New Sliding Seals on SSEB Weld Bead . . . . .   | 43          |

LIST OF ILLUSTRATIONS (Con't)

| <u>Figures</u>   | <u>Page</u> |
|--|-------------|
| 22. Sliding Seal Set No. 2 - Wear Caused by Repeated Aluminum<br>Bead-On-Plate Welding .....       | 44          |
| 23. Sliding Seal Set No. 3 - Wear Caused by Long Butt Welding on<br>Aluminum Plate .....           | 45          |
| 24. Macro-Section of Ti-6Al-4V Titanium Alloy Butt Weld .....                                      | 49          |
| 25. Large Tears in Sliding Seals after Welding Titanium Plate .....                                | 53          |
| 26. Sliding Seal Set No. 6 - Wear caused by Repeated Titanium<br>Bead-on-Plate Weld .....          | 54          |
| 27. Sliding Seal Set No. 7 - Wear caused by Short Test Panel Butt<br>Welds on Titanium Plate ..... | 55          |
| 28. Sliding Seal Set No. 9 - Wear Caused by Long Butt Welding on<br>Titanium Plate .....           | 56          |
| 29. Sliding Seal Head Assembly Removed from Welder .....   | 57          |
| 30. Bellows Remounted Below SSEB Gun Chamber .....   | 58          |
| 31. Base Support Ring for Cylinder Welding .....   | 60          |
| 32. Cylinder Weld Tooling Setup .....  | 61          |
| 33. Cylinder on Aronson Positioner .....   | 63          |
| 34. Cylinder in Position for GTA and SSEB Welding .....  | 64          |
| 35. Curved Head Plate for SSEB Welder .....  | 65          |
| 36. Sliding Seals and Radiation Shielding on Curved Head Plate .....                               | 66          |
| 37. SSEB Head Assembly with Curved Head Plate Mounted in<br>Vertical Position .....                | 67          |
| 38. MIG Welding Setup For Cylinder .....   | 69          |
| 39. Partially Welded Cylinder .....  | 70          |
| 40. Lower Half of Cylinder on Fixture .....  | 71          |
| 41. Inflatable Seal in Released Position .....   | 72          |

LIST OF ILLUSTRATIONS (Con't)

| <u>Figures</u>  | <u>Page</u> |
|---|-------------|
| 42. Inflatable Seal in Expanded Position . . . . .  | 73          |
| 43. Five to Seven-Foot-Long Section of SSEB Cylinder Weld . . . . .                         | 75          |
| 44. Eight to Ten-Foot-Long Section of Cylinder Weld . . . . .                               | 76          |
| 45. Close-up View of SSEB Cylinder Weld . . . . .   | 77          |
| 46. Sliding Seals After Cylinder Weld . . . . .   | 78          |
| 47. Special Shapes Welding Chamber . . . . .  | 80          |
| 48. Special Shapes Fixture Inserts and Roller Guides . . . . .                              | 81          |
| 49. Round Insert Parts and Tee Shape . . . . .  | 81          |
| 50. Ti-6Al-4V Titanium Alloy Tee Shapes for Use in Special-Shapes Fixture . . . . .         | 83          |
| 51. 20-14-T651 Aluminum Alloy Tee Shapes for Use in Special-Shapes Fixture . . . . .        | 83          |
| 52. Components Used to Mold Silicone Rubber Tee Seals . . . . .                             | 84          |
| 53. Special Shapes Welding Fixture . . . . .  | 85          |
| 54. SSEB Butt Weld Made on 0.300-Inch-Thick 2014-T651 Aluminum Alloy Tee Shape . . . . .    | 88          |
| 55. Preheat Steel Welding Fixture . . . . .   | 92          |
| 56. Fixture Used to SSEB-Weld 0.880-Inch-Thick HY 130 Steel Plate . . . . .                 | 93          |
| 57. Heatup Rates for Preheat Steel Welding Fixture and One-Inch-Thick Steel Plate . . . . . | 94          |
| 58. Steel Plate Preheating Rates with Parallel Connection and Fixture Open to Air . . . . . | 94          |
| 59. 0.880-Inch-Thick HY 130 Steel Plate SSEB Welded With and Without Preheating . . . . .   | 98          |
| 60. Macro-Section of HY 130 Steel Butt Weld Preheated Before Welding . . . . .              | 101         |

LIST OF ILLUSTRATIONS (Con't)

| <u>Figures</u>   | <u>Page</u> |
|--|-------------|
| 61. Cross-Section of D6AC Steel Butt Weld Preheated Before Welding . . . | 101         |
| 62. F-14 Wing Beam Sections . . . . .                                    | 107         |
| 63. Fixture Alignment in Vacuum Box . . . . .                            | 112         |
| 64. Vacuum Box With Wing Beam Fixture . . . . .                          | 113         |
| 65. SSEB/Slot Weld Setup-Vacuum Box . . . . .                            | 115         |
| 66. Welded F-14 Wing Beams . . . . .                                     | 119         |
| 67. Ultrasonic Inspection - Section No. 1 . . . . .                      | 122         |
| 68. Ultrasonic Inspection - Section No. 2 . . . . .                      | 123         |
| 69. Ultrasonic Inspection - Section No. 3 . . . . .                      | 124         |
| 70. Test Specimen Location-Wing Beam No. 5 . . . . .                     | 126         |
| 71. Base Metal Tensile Coupon (45 MPS 241) . . . . .                     | 127         |
| 72. Transverse Weld Tensile Coupon (TGS 5350) . . . . .                  | 128         |
| 73. Longitudinal Weld Tensile Coupon (TGS 5359) . . . . .                | 129         |
| 74. Wing Beam Tensile Coupons . . . . .                                  | 130         |
| 75. Close-Up View of Tensile Coupon Failure Location . . . . .           | 131         |
| 76. Fracture Toughness Specimen (TGS 1094) . . . . .                     | 133         |
| 77. Wing Beam Fracture Toughness Specimen . . . . .                      | 135         |
| 78. Close-Up View of Fracture Toughness Failure Location . . . . .       | 136         |
| 79. Fatigue Weld Test Specimen (45 MPS 240) . . . . .                    | 137         |
| 80. Wing Beam Fatigue Test Specimen . . . . .                            | 140         |
| 81. Close-Up View of Fatigue Failure Location . . . . .                  | 141         |
| 82. Weld Test Specimen . . . . .   | 165         |
| 83. Cosmetic Pass Weld Test Specimen . . . . .                           | 166         |

LIST OF TABLES

| <u>Number</u> |   | <u>Page</u> |
|---------------|---|-------------|
| 1.            | Verification of Constant-Current and Overload Control Units<br>by Sliding Seal EB Welds in One-Half-Inch-Thick 2014 T651<br>Aluminum Alloy Plate . . . . .                      | 20          |
| 2.            | Parameter Development for 1/2-Inch-Thick 2024-T351<br>Aluminum Alloy Plate for Cylinder Welding Application . . . . .   | 22          |
| 3.            | Receipt and Acceptance Status of Test Materials . . . . .   | 24          |
| 4.            | Chemical Analyses of As-Received Materials . . . . .  | 25          |
| 5.            | Seal Wear Study Program . . . . .   | 26          |
| 6.            | Initial SSEB Welding Parameters and Results for<br>Bead-on-Plate Welds Made in One-Inch-Thick, 2014-T651<br>Aluminum Alloy Plate Using the Flat Plate Welding Fixture . . . . . | 33          |
| 7.            | SSEB Butt Weldments on One-Inch-Thick 2014-T651 Aluminum<br>Alloy Plate (24-Inch-Long Test Welds Using Cover Plate on<br>Flat Plate Welding Fixture) . . . . .                  | 38          |
| 8.            | Tensile Properties of One-Inch-Thick 2014-T651 Aluminum<br>Alloy Base Metal . . . . .   | 39          |
| 9.            | Tensile Properties of SSEB Welded One-Inch-Thick 2014-T651<br>Aluminum Alloy (Square Butt Joint, Flat Position, as Welded<br>Condition) . . . . .                               | 39          |
| 10.           | Sliding Seal Life/Wear Results for Bead-on-Plate and Butt<br>Welds on 2014-T651 Aluminum Alloy Plate . . . . .  | 42          |
| 11.           | SSEB Bead-on-Plate Weldments on Ti-6Al-4V Titanium Alloy<br>Plate (Parameter Development and Seal Life-Wear Study) . . . . .  | 47          |
| 12.           | SSEB Butt Weld Parameters Used to Weld 0.880-Inch-Thick<br>Ti-6Al-4V Titanium Alloy Plate . . . . .   | 50          |
| 13.           | Tensile Properties of 0.880-Inch-Thick Ti-6Al-4V Titanium<br>Alloy Base Metal (Stress Relieved After Machining) . . . . .   | 51          |
| 14.           | Tensile Properties of SSEB Welded 0.880-Inch-Thick Ti-6Al-4V<br>Titanium Alloy Plate (Square Butt Joint, Flat Position, Stress<br>Relieved After Machining) . . . . .           | 51          |

LIST OF TABLES (Con't)

| <u>Number</u> |   | <u>Page</u> |
|---------------|---|-------------|
| 15.           | Sliding Seal Life/Wear Results for Bead-on-Plate and Butt Welds on Ti-6Al-4V Titanium Alloy Plate . . . . .   | 52          |
| 16.           | SSEB Welding Parameters and Results for Butt Welds Made on 0.300-Inch-Thick 2014-T651 Aluminum Alloy Tee Angles . . . . .   | 87          |
| 17.           | SSEB Welding Parameters and Results for Butt Welds Made on 0.300-Inch-Thick Ti-6Al-4V Titanium Alloy Tee Angles . . . . .   | 90          |
| 18.           | SSEB Welding Bead-on-Plate Parameters and Results for Welds Made on 0.440-Inch-Thick Plate . . . . .  | 96          |
| 19.           | SSEB Welding Parameters and Results for Butt Welds Made on 0.880-Inch-Thick HY 130 Steel Plate . . . . .  | 97          |
| 20.           | SSEB Welding Bead-on-Plate Parameters and Results for Welds Made on One-Inch-Thick D6AC Steel Plate . . . . .   | 100         |
| 21.           | Tensile Properties of 0.880-Inch-Thick HY 130 Steel Alloy Base Plate . . . . .  | 102         |
| 22.           | Tensile Properties of SSEB 0.880-Inch-Thick HY 130 Steel Alloy Plate (Square Butt Joint, Flat Position, Preheated to 200°F Before Welding) . . . . .                                      | 102         |
| 23.           | Tensile Properties of 1.00-Inch-Thick D6AC Steel Alloy Base Metal (Stress Relieved After Machining) . . . . .   | 103         |
| 24.           | Tensile Properties of SSEB Welded 1.00-Inch-Thick D6AC Steel Alloy Plate (Square Butt Joint, Flat Position, Preheated to 350°F Before Welding, Stress Relieved After Machining) . . . . . | 103         |
| 25.           | 0.300-Inch-Thick Ti-6Al-6V-2Sn Titanium Alloy Plate Weld Series . . . . .   | 108         |
| 26.           | 0.300-Inch-Thick Ti-6Al-6V-2Sn Titanium Alloy Extrusion Weld Series . . . . .   | 111         |
| 27.           | Slot Weld Test Weld Series . . . . .  | 116         |
| 28.           | Wing Beam Welding . . . . .   | 118         |
| 29.           | Radiographic Results of SSEB/Slot Welded Ti-6Al-6V-2Sn Titanium Alloy Wing Beams . . . . .  | 121         |
| 30.           | Tensile Properties of 0.300-Inch-Thick Ti-6Al-6V-2Sn Titanium Alloy Extrusion Base Metal (Stress Relieved After Machining) . . . . .  | 132         |

LIST OF TABLES (Con't)

| <u>Number</u> |   | <u>Page</u> |
|---------------|---|-------------|
| 31.           | Tensile Properties of SSEB Welded 0.300-Inch-Thick Ti-6Al-6V-2Sn Titanium Alloy Extrusion (Square Butt Joint, Flat Position, Stress Relieved After Machining) . . . . .                     | 132         |
| 32.           | Fracture Toughness Properties of Base and SSEB Welded 0.300-Inch-Thick Ti-6Al-6V-2Sn Titanium Alloy Extrusion (Square Butt Joint, Flat Position, Stress Relieved After Machining) . . . . . | 134         |
| 33.           | Fatigue Properties of 0.300-Inch-Thick Ti-Al-6V-2Sn Titanium Alloy Extrusion Base Metal (Stress Relieved After Machining) . . . . .   | 138         |
| 34.           | Fatigue Properties of SSEB Welded 0.300-Inch-Thick Titanium Alloy Extrusion (Square Butt Joint, Flat Position, Stress Relieved After Machining) . . . . .                                   | 139         |
| 35.           | Titanium, Aluminum and Steel Alloys and Filler Metals . . . . .   | 167         |
| 36.           | Required Parameters to be Recorded in Welding Schedule . . . . .  | 168         |
| 37.           | Gas-Tungsten-Arc (GTA) Seal-Welding Parameters for Ti-6Al-4V Titanium Alloy and 2014-T651 Aluminum Alloy Plate Materials . . . . .  | 169         |
| 38.           | Steel Thermal Process Requirements . . . . .  | 169         |

## SECTION I

### INTRODUCTION

#### A. PURPOSE

The purpose of this program was to improve manufacturing techniques, increase the flexibility of the sliding-seal electron-beam (SSEB) welding equipment, generate welding data, and establish production acceptance of the SSEB welding process for diverse aerospace applications.

#### B. OBJECTIVES

The objectives of the program were:

- Design, fabricate, and checkout tooling fixtures for long, flat-plate welding; cylinder welding (12-foot-diameter); complex-shape welding (Tees) and welding of high-strength alloy steels in a special preheat vacuum chamber box
- Evaluate seal wear on a long, flat-plate welding fixture
- Install constant-current and overload-control units
- Make equipment-head modifications necessary for welding a 12-foot-diameter cylinder
- Demonstrate the capability of the SSEB welding equipment to weld a selected, simulated airframe component.

At the conclusion of the program, an SSEB welding equipment specification was written for use by the aerospace industry.

#### C. PROGRAM SCOPE

This project consisted of the following phases:

- Phase I - Design Effort
- Phase II - Fabrication and Checkout of Welding Fixtures
- Phase III - Specification Preparation and In-House Demonstration.

The tasks in each phase were defined so as to establish the complete flexibility of the SSEB welding equipment, which was previously limited to short, flat-plate welding. The program tasks of each phase were as follows:

### 1. Phase I - Tool Design for SSEB Flexibility

The contractor identified and established approaches to extend the flexibility of the SSEB welding process to permit its application to a variety of structural shapes and sizes. Tooling concepts were finalized. Detailed prints were drawn for the following welding tools:

- Long, flat-plate welding fixture (10 feet or more, with stationary SSEB gun and moving part)
- Cylinder welding fixture (stationary SSEB gun)
- Special-shapes welding fixture (movable SSEB gun and stationary part) for channels, tees, etc.
- Preheat welding fixture (for high-strength, heavy steel plate).

### 2. Phase II - Tool Fabrication, Installation and Check-Out

After completion of Phase I and receipt of approval to continue with Phase II, the weld tooling hardware was fabricated and installed in the SSEB weld area adjacent to the SSEB welding equipment. A performance checkout of each welding fixture was made to verify the tooling concept. Bead-on-plate welds and several butt welds (longer than 10 feet) were made with the flat-plate welding fixture. A seal life/wear study was also conducted on this fixture. Weldments were made in both titanium and aluminum alloys. A 12-foot-diameter cylinder was fabricated from 1/2-inch-thick 2024-T351 aluminum alloy and was welded in the horizontal position. A special joint configuration (angle) was evaluated using a special shapes tooling fixture. Welding of crack sensitive steels was accomplished in a preheat-vacuum chamber designed to preheat the steel before welding. Techniques for filler wire addition were also evaluated during this phase. Special controls, such as constant current and overload control units, proximity, and seam tracking were evaluated for use on the cylinder.

### 3. Phase III - Process Demonstration

At the conclusion of the program, an in-house demonstration was held to familiarize interested aerospace companies, manufacturers of electron-beam (EB) welding equipment, government personnel, and interested companies with the work performed during the course of the contract. A demonstration weldment on a selected production airframe component was made at that time. Arrangements for this demonstration were made with the concurrence of the Air Force Monitor.

### 4. Specification Definition

All welding data generated in the performance of this contract was analyzed to define an EB equipment specification written at the conclusion of the program. This specification incorporates all the necessary information regarding the SSEB welder and power source, the special head modifications for certain types of weldments, special welding fixtures, and backup tooling for production applications.

#### D. BACKGROUND INFORMATION

The SSEB welding system utilized in this program (Figure 1) was designed and manufactured by Sciaky Bros., Inc., under Air Force Contract AF33(615)-5277 (Ref 1). This unit consists of a portable, vacuum, moving EB welding head mounted on a ram manipulator, backup tooling, and associated power supply and controls. The power capacity of this unit is 30 kw (60 kv, 500 ma) and capable of welding at vacuum pressures ranging between  $1 \times 10^{-4}$  torr and 100 microns Hg. The backup-table vacuum pressure is maintained between 10 and 50 microns Hg. The vacuum in the moving welding head is obtained by pumping between two silicone rubber vacuum seals (in the head) that ride on the workpiece being welded.

The ram manipulator, which supports the welding head and associated vacuum pumping equipment, is capable of traversing a distance of 6 feet in the flat position (X axis), and 5 feet in the vertical position (Z axis). The vacuum sealed backup tool is capable of being used in the flat position or remounted in the vertical position. Use of the SSEB welder permits welding of large aerospace structures that cannot be welded in available chambers. The ram manipulated boom and column assembly is mounted on a rotatable base, which provides 360-degree rotation about the Z axis. This rotation permits positioning of the local welding chamber over the joint to be welded, and welding in more than one quadrant. The EB gun, local welding chamber, and associated vacuum pumping equipment are mounted on the end of the boom to reduce the length of the pumping lines.

*In September 1970, the SSEB welder was installed at Grumman in a production plant area adjacent to the EB welding facility. This was accomplished under Air Force Contract F33615-70-C-1806. Sciaky field service engineers assisted Grumman Facilities Engineering and Maintenance personnel with the installation. Advanced Materials and Processes Development personnel assisted with the functional checkout of the equipment and the familiarization and training effort. After the equipment was checked and Grumman personnel trained in its operation, 24-inch-long square butt joints were welded from 1/2-inch-thick 2014-T651 aluminum alloy plate and 1/4-inch-thick Ti-6Al-4V titanium alloy plate to verify equipment capability.*

The SSEB welding equipment was then used to establish optimum welding parameters for square butt joints made from 0.250-, 0.500-, 0.750-, and 1.00-inch-thick 2014-T651 aluminum alloy plate and annealed Ti-6Al-4V alloy plate, and 1.00-inch-thick HY-130 steel alloy plate. Seal reliability, filler metal addition, repair weldability, and proper seal pass techniques were determined and verified for subsequent efforts to extend the SSEB welding process to production hardware. Tensile, fatigue, and fracture toughness data were obtained on typical square butt welds in the above thicknesses made by flat and vertical welding techniques. All weldments were non-destructively tested by radiographic, dye-penetrant, and ultrasonic methods. Metallographic results were correlated with mechanical properties. All weld parameter data and tensile, fatigue, and fracture toughness data were tabulated and listed in Technical Report AFML-TR-72-287, January 1973 (Ref. 2).

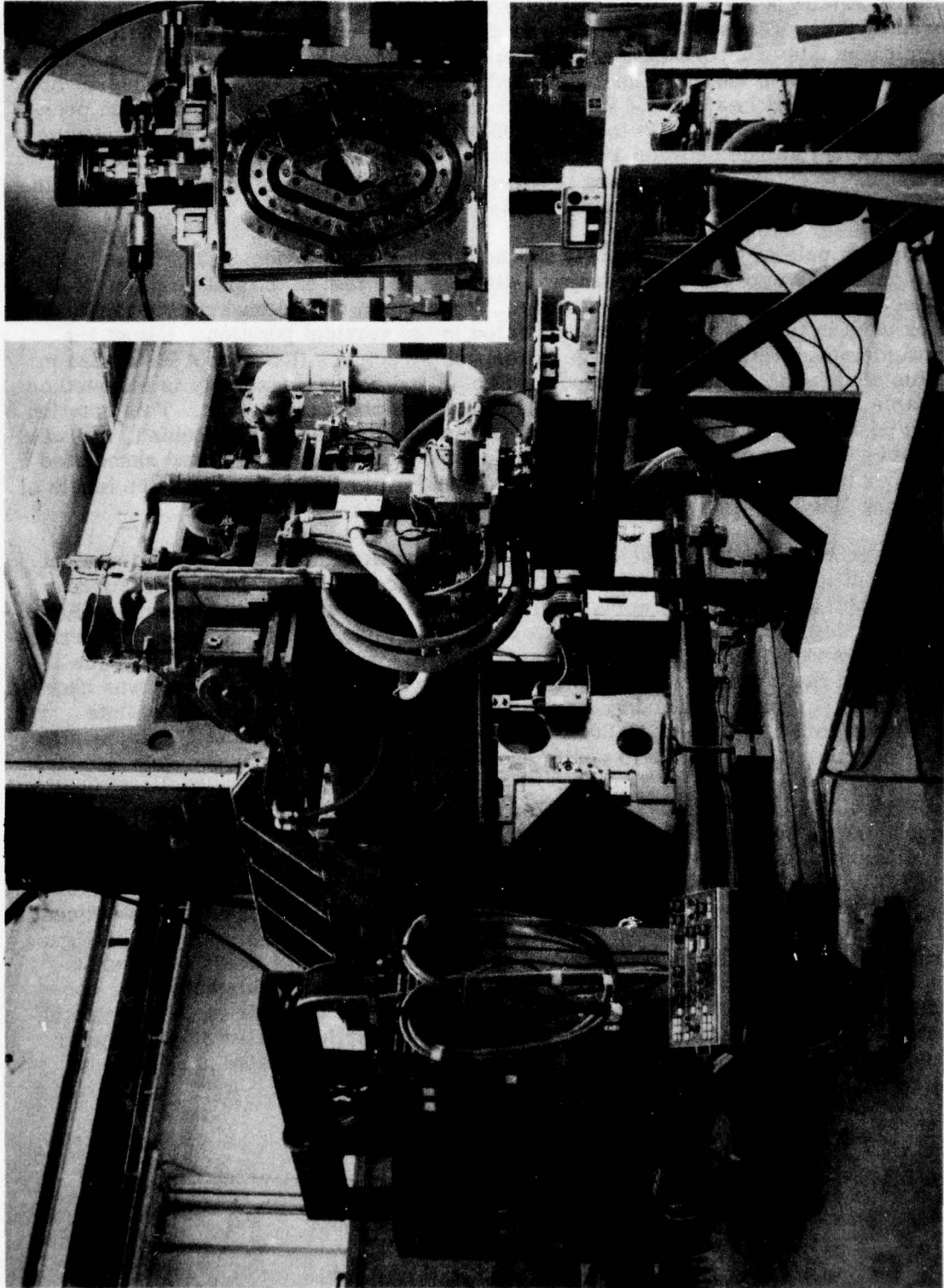

Figure 1 Sliding-Seal Electron-Beam Welder

The SSEB welding equipment was also used to demonstrate its capability to fabricate a simulated structural component - a stiffened titanium wing skin panel. The welded panel was subjected to fatigue tests under simulated loadings for advanced fighter aircraft structures. The panel was also evaluated for repair capability, weld penetration, surface and underbead appearance, shrinkage, and distortion. Weld soundness of the panel was determined by radiographic, dye-penetrant, and ultrasonic inspection techniques. All test results were tabulated, reviewed, analyzed, and compared with results available on similar structural components welded in the large, Grumman EB welding chambers and on gas-tungsten-arc (GTA) or gas-metallic-arc (GMA) equipment.

The status of the SSEB welding equipment at the conclusion of the referenced program can be summarized as follows:

- Aerospace-quality, flat butt panels up to 2 ft in length are fabricable from:
  - 1/4- to 1-inch-thick 2014-T651 aluminum alloy plate
  - 0.190- to 0.940-inch-thick Ti-6Al-4V titanium alloy plate
  - 0.440-inch-thick HY-130 steel alloy plate
- Optimized SSEB welding parameters are similar to hard vacuum EB parameters for Ti-6Al-4V titanium and 2014-T6 aluminum alloy
- Tensile, fatigue, and fracture toughness values obtained for SSEB butt welds are comparable to production EB weld properties for Ti-6Al-4V titanium alloy
  - Tensile fatigue joint efficiencies = 100% of base metal
  - Fracture toughness ( $K_{IC}$ ) = 39.0, minimum, for base metal having  $F_{ty} = 55.4$  ksi
- GTA butt joint seal welding prior to full penetration SSEB welding produced porosity free welds in all alloys and thicknesses used in this program
- Penetration in SSEB welds can be obtained readily in thicknesses up to:
  - 2.0 inches for 2014-T6 aluminum alloy
  - 1.5 inches for Ti-6Al-4V titanium alloy

Heavier gages are feasible for short welds (up to 2 feet long)

- Tensile and fatigue strengths for SSEB welded 2014-T6 aluminum alloy are comparable to EB hard vacuum welds
  - Tensile joint efficiency = 75-80% of base metal
  - GTAW joint efficiency = 65% of base metal
  - GMAW joint efficiency = 60% of base metal
- $K_{IC}$  fracture toughness of SSEB welds in 2014-T6 aluminum alloy requires thicknesses greater than one inch for valid data acquisition

- SSEB welding of 2014-T6 aluminum alloy at speeds greater than 60-80 ipm degrades mechanical properties and can result in transverse cracks at the fusion line and in the weld bead
- Welds were limited to two feet by fixture size and boom travel distance
- Additional work was required to extend the capability and versatility of the equipment for various applications, since weld joints were proven to be equivalent to normal EB production welds

## SECTION II

### PHASE I - TOOL DESIGN FOR SLIDING-SEAL ELECTRON-BEAM WELDING FLEXIBILITY

#### A. APPROACH AND WORK AREAS

The SSEB welding process has demonstrated capability for achieving aerospace-quality weldments in aluminum and titanium alloys equivalent to "hard" vacuum, electron beam welding under Air Force Contract No. F33(615)-C-70-1806 (Ref. 3). The purpose of the present program was to make weldments of significant size and shapes so as to make the SSEB welding equipment more readily acceptable for production applications. The main effort in this task was the conception and design of tooling and fixtures necessary to extend the capability of the SSEB welding equipment in order to obtain the necessary data to determine equipment specification requirements for future production applications.

This effort covered the following work areas:

- Design of four weld tooling fixtures
- Equipment Head modification changes
- Equipment modifications - special control units
- Area layout for welding fixtures
- Material procurement and weld coupon fabrication
- Seal life/wear evaluation planning.

#### B. TOOL DESIGN

Tool design layouts for the four proposed welding fixtures were finalized. Detailed prints were prepared from these layouts. No significant tooling or vacuum design problems were encountered in the design of the fixtures even though new approaches were used to vacuum-seal the cylinder and the special-shapes welding fixture.

##### 1. Flat Plate Welding Fixture

This task was concerned with design of tooling to accomplish long-length butt welds in large flat plates with the SSEB equipment. The boom and welding head remained stationary and the parts were moved under the head on a moving fixture set-up. The lower section of the gun assembly (sliding-seal clamping plate) was rotated 90 degrees from its original set-up position. The weld fixture (three foot wide, one foot high and 15 feet long) with a lower vacuum chamber and hold down assembly was designed to move along on the top of a support table. The weld fixture was used to make bead-on-plate and butt welds of 10 feet or more in length. The seal life/wear study was also conducted on this fixture.

Preliminary sketches of a weld fixture-table setup were made to establish design criteria such as table size, vacuum pump layout, pump requirements, "O" ring sealing and drive motor requirements. Facilities Engineering personnel were requested to give recommendations on motor drive and vacuum procedures and requirements for the table. Layouts and detailed drawings for the support table were completed (Figure 2). Two Inspection Checking Fixture (ICF) tables were modified with support blocks to raise the tables to the desired welding height. Thomson Roundway bearings and ways were mounted on the tables for travel motion. A motor-chain drive gear-package was evaluated for potential use by Facilities Engineering. The feasibility of interconnecting the motor drive to the Sciaky consoles on the SSEB welder was studied.

The layout design of the welding fixture was finalized (Figure 3). Detailed drawings were made from this layout. Floor-mounted vacuum pumps were used to evacuate the weld fixture and a Power-trak guided the vacuum hose alongside the weld table. This assembly eliminated any vibrations from the vacuum pump that might have caused a problem during welding.

## 2. Cylindrical Welding Fixture

Layouts of the cylinder welding fixture were completed. The cylindrical welding fixture was used exclusively to conduct a preliminary feasibility evaluation of the tooling developed for cylinders and was evaluated at the end of the proposed Phase II effort. An Aronson Positioner was used to hold the cylinder in the horizontal position for welding (Figure 4). A solid backup ring with inflatable "O" ring seals was used for the backup vacuum welding area (Figure 5). B. F. Goodrich of Akron, Ohio, was contacted regarding their inflatable seals. Two "O" ring types were considered for the design. Hard-line vacuum tubing was used in the backup ring. A swivel connection located at the center of the ring assembly connected the hard tubing to a flexible vacuum line from the vacuum pump. The hard-line vacuum tubing and swivel connections eliminated the need for a long flexible hose. The support tooling and brackets for the cylinder support and the Aronson Positioner turntable layouts were fabricated.

## 3. Special Shapes Welding Fixture

The special shapes fixture was utilized to obtain data for welding structures that have special section shapes (e.g., T's, L's) such as those found in beams, bulkheads and stringers. Preliminary design sketches were made to determine part configurations, tooling requirements for part alignment, molded vacuum seals, space limitations of fixture, interchangeability of parts and turning of the workpiece for a two-pass weldment. Design concepts were finalized and the layout drawing prepared. Detailed prints were then finalized from these layouts. Figures 6 and 7 show end and side views, respectively, of the fixture set up for a Tee configuration.

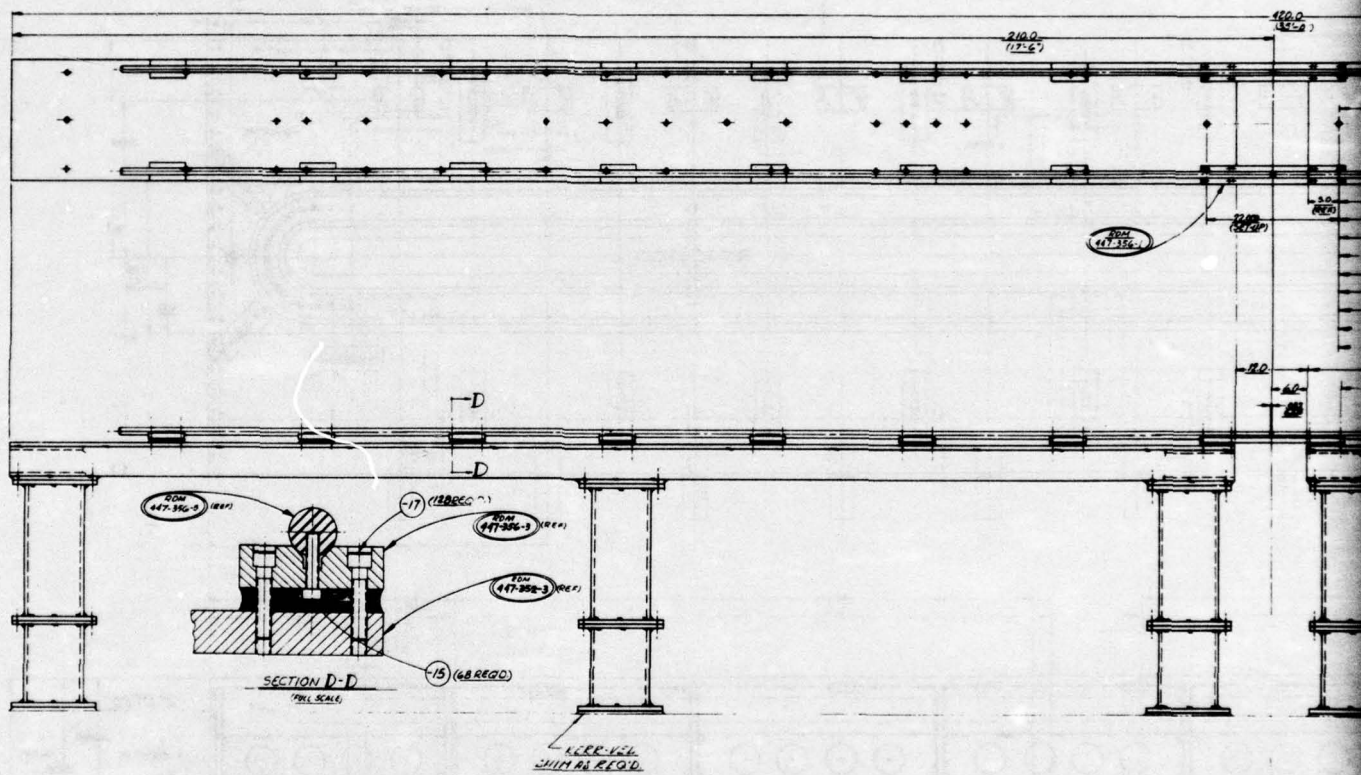

① ASSEMBLY

2. FIXTURE

1" DIA. 1/8" TAPPED HOLES - PER DIMS.  
NOT SHW. SEE DRAWG. WT-3576-101 (REF.)

117-356-3 (APP'D)

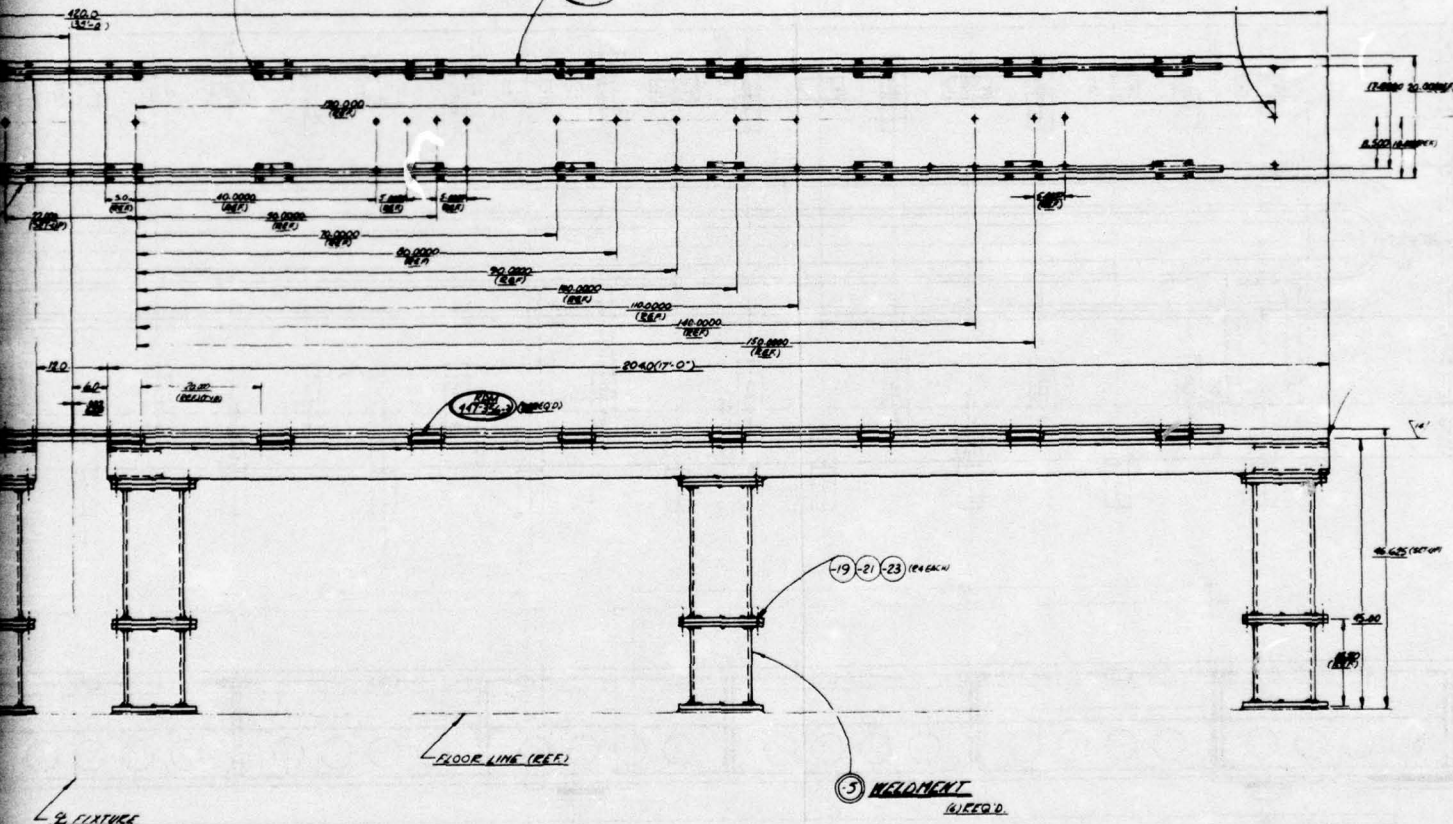
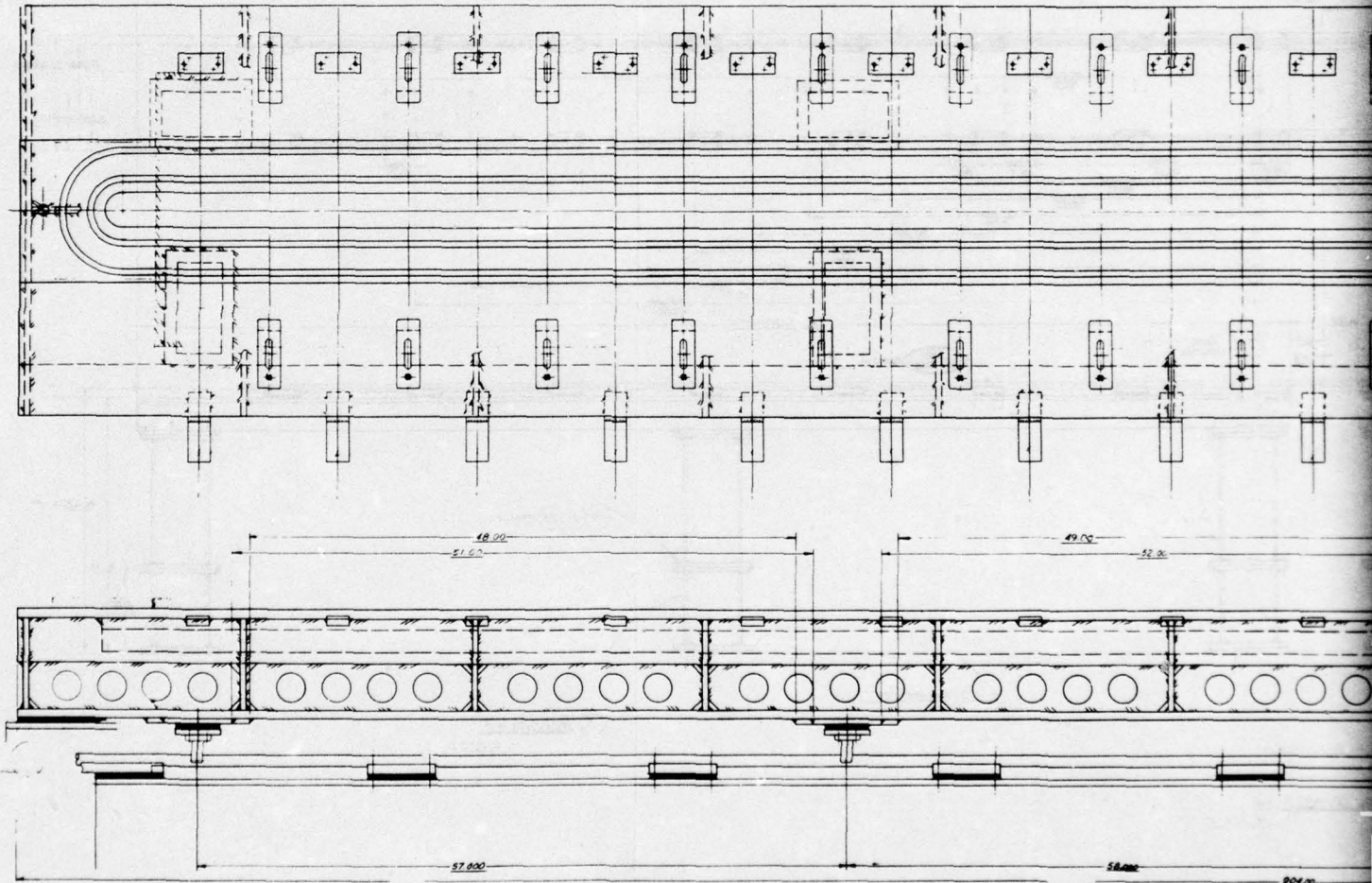

Figure 2 Support Table for Flat Plate Welding Fixture

2



204.00  
 (17-0)

Figure 3 Support from the first  
 Working figure

1



12 FOOT DIAMETER CYLINDER  
1/2 INCH THICK 2024-T351 TEST ALUMINUM ALLOY PLATE

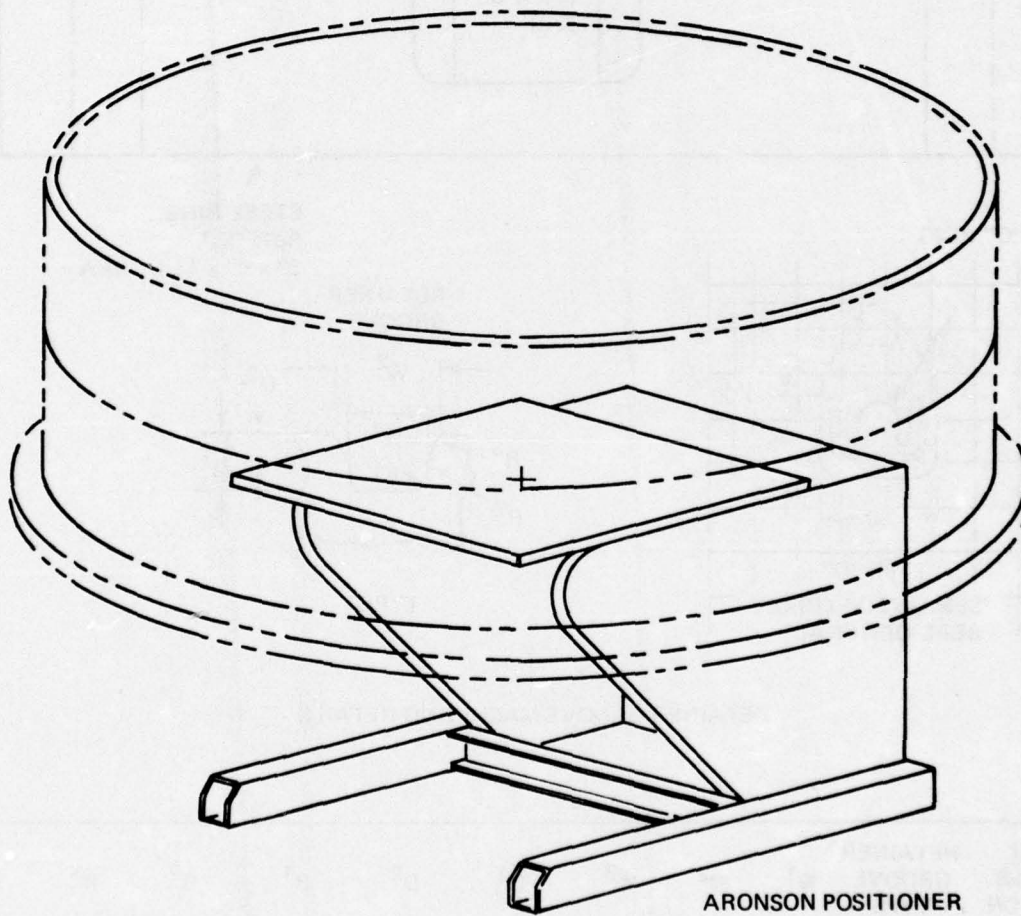
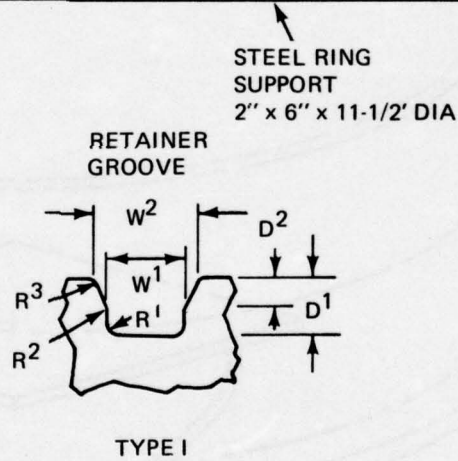
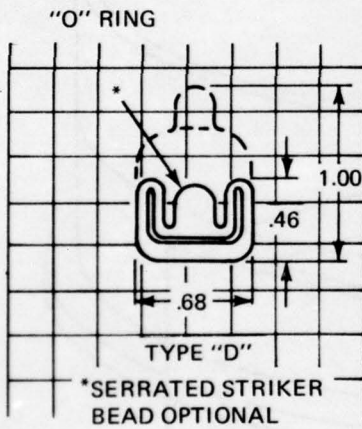
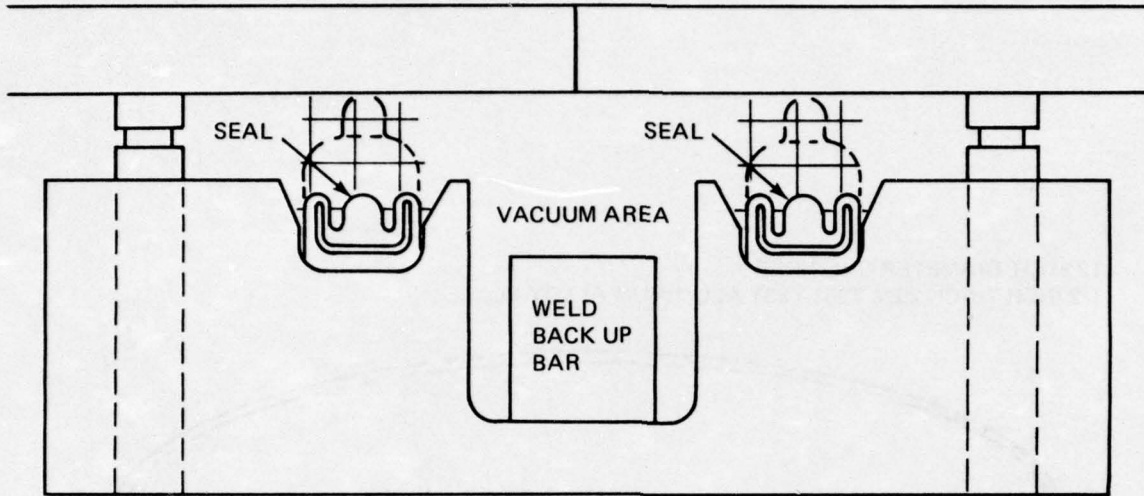

Figure 4 Cylindrical Welding Setup

1/2 INCH-2024-T351 ALUMINUM ALLOY PLATE



RETAINER GROOVE MACHINING DETAILS

| SEAL CROSS SECTION | RETAINER GROOVE TYPE | W <sup>1</sup> | W <sup>2</sup> | W <sup>3</sup> | D <sup>1</sup> | D <sup>2</sup> | R <sup>1</sup> | R <sup>2</sup> | R <sup>3</sup> | R <sup>4</sup> |
|--------------------|----------------------|----------------|----------------|----------------|----------------|----------------|----------------|----------------|----------------|----------------|
| D                  | 1                    | .703           | .900           | -              | .500           | .250           | .120           | .062           | .062 MIN       | -              |

Figure 5 Cylinder Vacuum Sealing

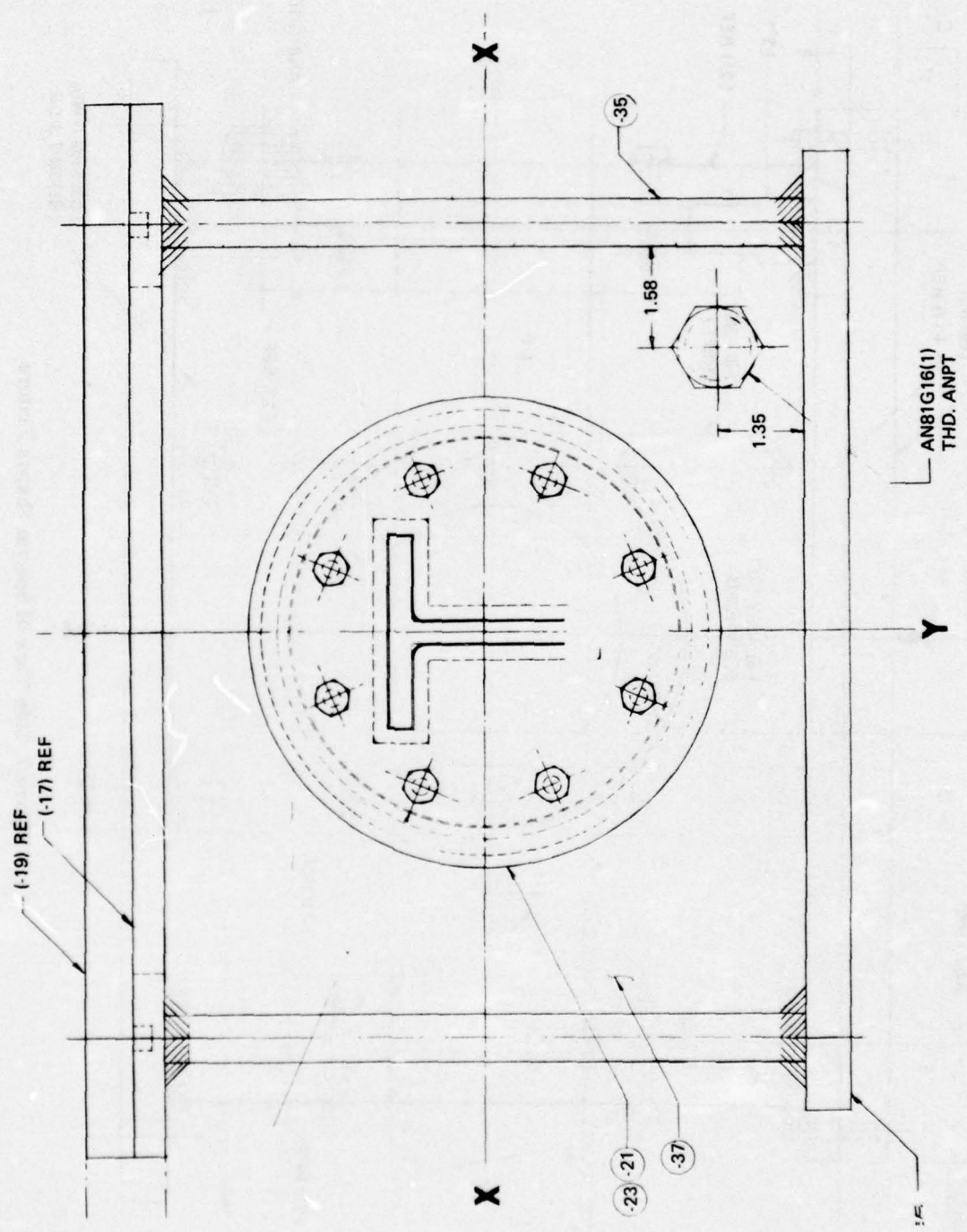

Figure 6 End View of Special Shapes Fixture

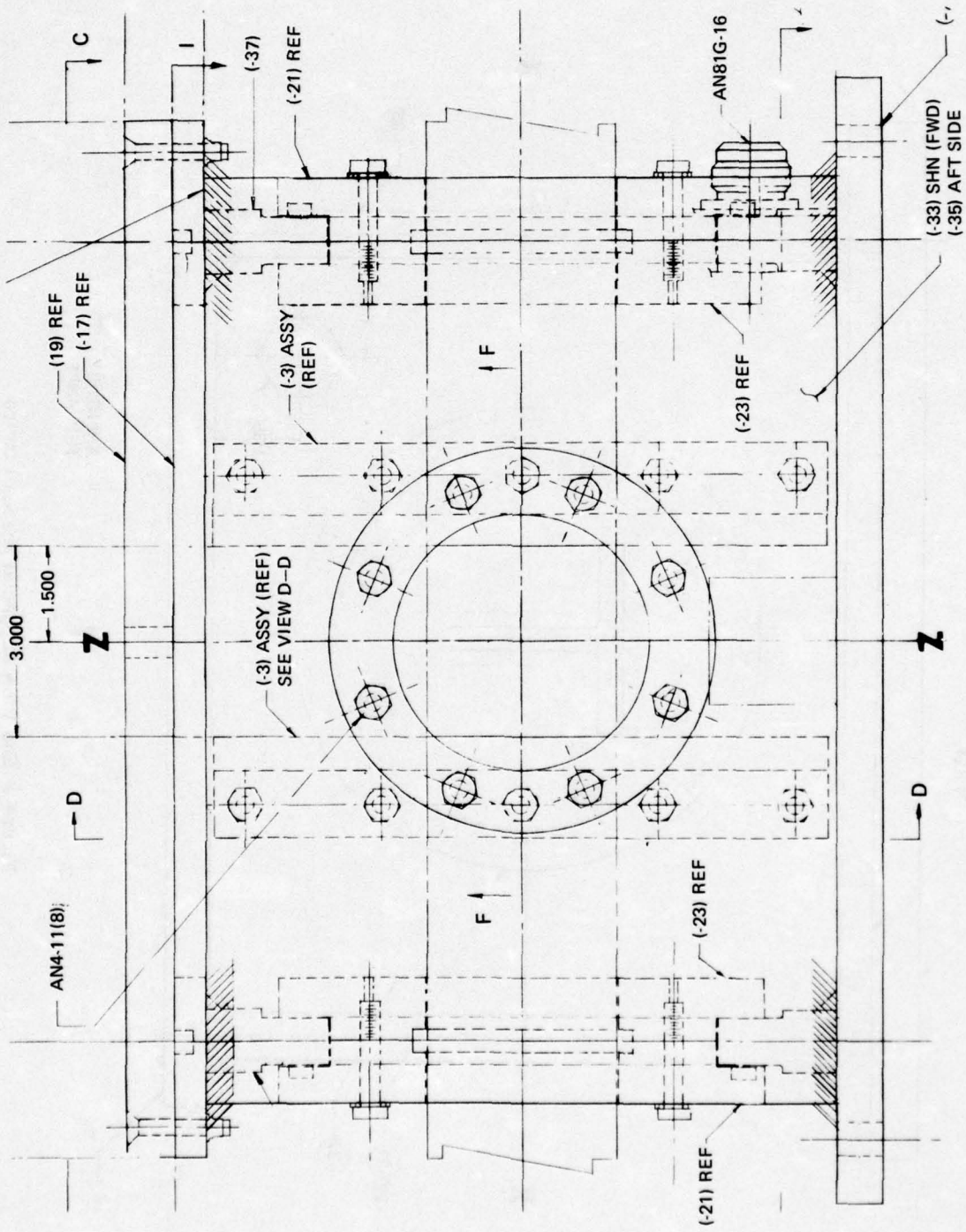

Figure 7 Side View of Special Shapes Fixture

#### 4. Preheat Steel Welding Fixture

Previous SSEB welding of alloy steels in one-inch-thick HY-130 and D6AC steels showed that post-weld cracking occurred. Past experience with other welding processes showed that this tendency could be eliminated by preheating between 150° to 400°F. Design criteria were established to preheat the component to be SSEB welded. A fixture, consisting of a box in which a preheat weld fixture was enclosed in an SSEB welding chamber was designed and fabricated. A weld through cover sheet of the same composition of the steel being welded was to be utilized to maintain vacuum while welding. This requirement was eliminated later as described in Section III B.4.e. Preheating temperatures were maintained by means of electrical heating units that held the material at required temperatures. The SSEB weld head traversed over a cold cover-plate insulated from the box fixture.

Preliminary design sketches of a preheat-vacuum chamber setup were drawn to determine workpiece-to-cover distance, box opening for material setup inside chamber, vacuum sealing of top and cover sheet and heating element locations (Figure 8). Experimental work in the small, hard-vacuum electron-beam welding chamber showed that a one-inch cover-to-workpiece distance can be used on the SSEB weld fixture. This design criteria was incorporated in the preliminary drawing. Detailed drawings were made from the preliminary layouts.

### C. EQUIPMENT MODIFICATIONS

#### 1. SSEB Head

A curved plate (Figure 9) for the head modification was designed. This plate formed the sliding seals to the 12-foot-diameter curvature needed for sealing on the outside of the cylinder. A two-foot-wide template having a 6-foot-radius arc was used in machining one-inch-thick aluminum alloy plate to the required configuration. The hole locations for vacuum ports and bolts to fasten the SSEB head assembly were transferred from the existing head plate. The same holding clamps that were used to hold the sliding seals in place on the present head were used on the curved head plate. Curved strips of lead-impregnated rubber were cut and adapted to the head plate for use as radiation shields.

#### 2. Special Control Units

- a. Constant Current and Overload Control Units - Previous experience with the SSEB welder showed that the control electrode manual adjustment for beam current had to be replaced by a constant-current and overload control to insure proper beam current during the welding cycle. This control, in addition to insuring constant beam current, would also permit selection of initial current setting, initial slope rate, final current setting and final slope rate settings. These slope controls are necessary to taper-out a cylindrical weld. Welding experience gained in "hard" vacuum

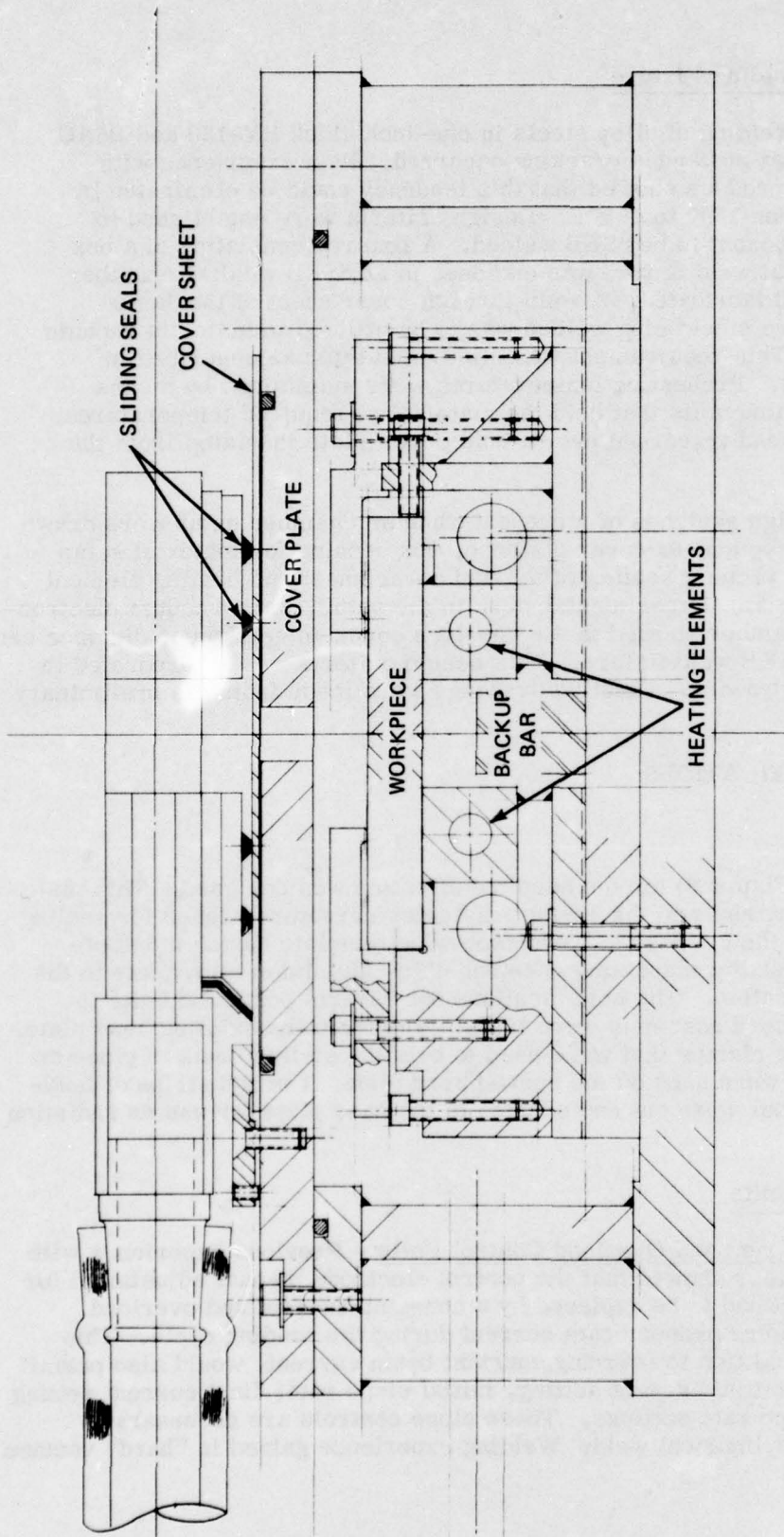

Figure 8 End View of Preheat Welding Fixture for Steels

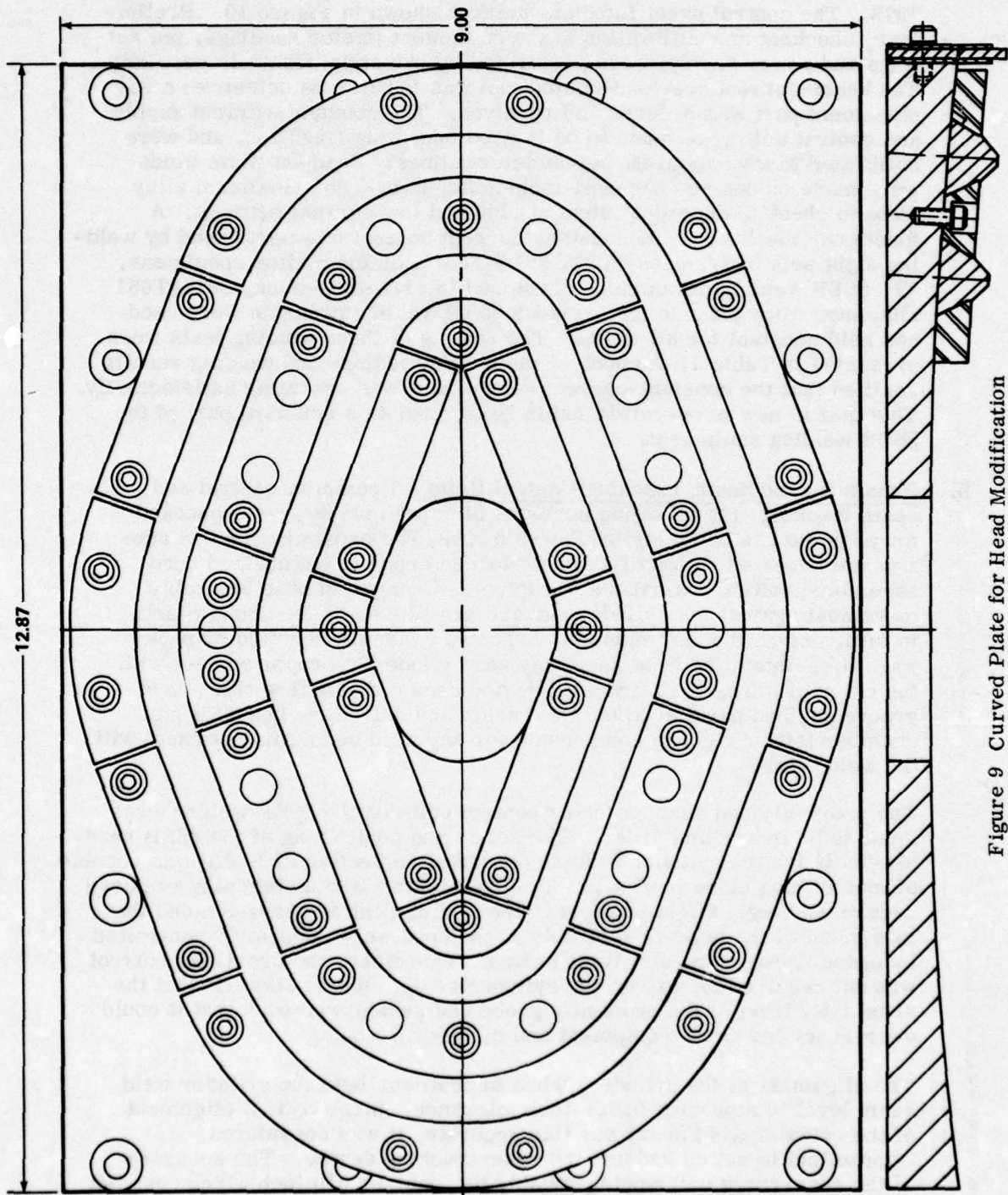

Figure 9 Curved Plate for Head Modification

equipment showed that tapered close-out of cylindrical welds is necessary to produce welds that have no internal defects. An overload control circuit shuts off the welding sequence if a surge in electron-beam current occurs for any reason, to prevent damage of the SSEB welder. Constant-current and overload control units were installed on the SSEB welder in November 1973. The control panel for these units is shown in Figure 10. Preliminary checkout and calibration of the equipment (meter readings, pot settings and power supply) were performed by Industrial Controls personnel. The beam-current overload-control pot was found to be defective; a replacement part was ordered and received. The constant-current supply and control unit were found to be in good operating condition, and were calibrated to give accurate pot-meter readings. Bead-on-plate welds were made on one and one-half-inch-thick, 2014-T651 aluminum alloy plate to check the current output at high and low current settings. A functional checkout of the constant-current control was performed by welding eight sets of 1/2-inch-thick, 2014-T651 aluminum alloy specimens. The SSEB welding parameters developed for 1/2-inch-thick, 2014-T651 aluminum alloy plate in the previous SSEB welding program were used and held constant for all welds. The results of these welding tests were presented in Table 1. A check of the meter readings and welding results verified that the constant-current control unit was operating satisfactorily. This unit is now in operation and is being used as a standard part of the SSEB welding equipment.

- b. Proximity and Seam Tracking Control Units - Proximity control and seam tracking, for following contours of curved plates, were checked for possible use on the cylinder weldment. The proximity control uses a vernier located on top of a spring-loaded probe to set desired head assembly position against the workpiece. Changes in head assembly movement against the cylinder surface are sensed by the probe which, in turn, drives the ram manipulator/boom assembly forward or backward to maintain the head assembly and cylinder in proper contact with the cylinder. The seam tracking device uses a stylus that rides on a groove scribed parallel to the weld seam and drives the head/EB gun chamber left or right to compensate for any weld seam misalignment with the weld beam.

The proximity and seam tracking control units on the SSEB welder were found to be in working order. The set up and positioning of the SSEB head assembly for the cylinder weld as described in Section III B.2.d was capable of maintaining close head seal - cylinder contact and maintaining required vacuum sealing. Slight changes in the sliding seal compression and the movement of the bellows assembly in the head were adequately controlled by proper positioning of a limit switch. Therefore, the proximity control was not required for use on the cylinder setup. It was also felt that the sensitivity level of the proximity probe and sensor was such that it could over-react and cause equipment and cylinder damage.

The alignment of the cylinder, when in position, held the cylinder weld seam level to a precise 0.025-inch tolerance. Since optical alignment of the cylinder weld seam was this accurate, it was considered impractical to set up and use the seam tracking device. The accuracy of the seam track unit would probably be about  $\pm 0.010$  inch which does not justify the need for the unit. Secondly, the weld bead made on test runs was .100 inch wide and this would weld any seam with .025-inch tolerance.

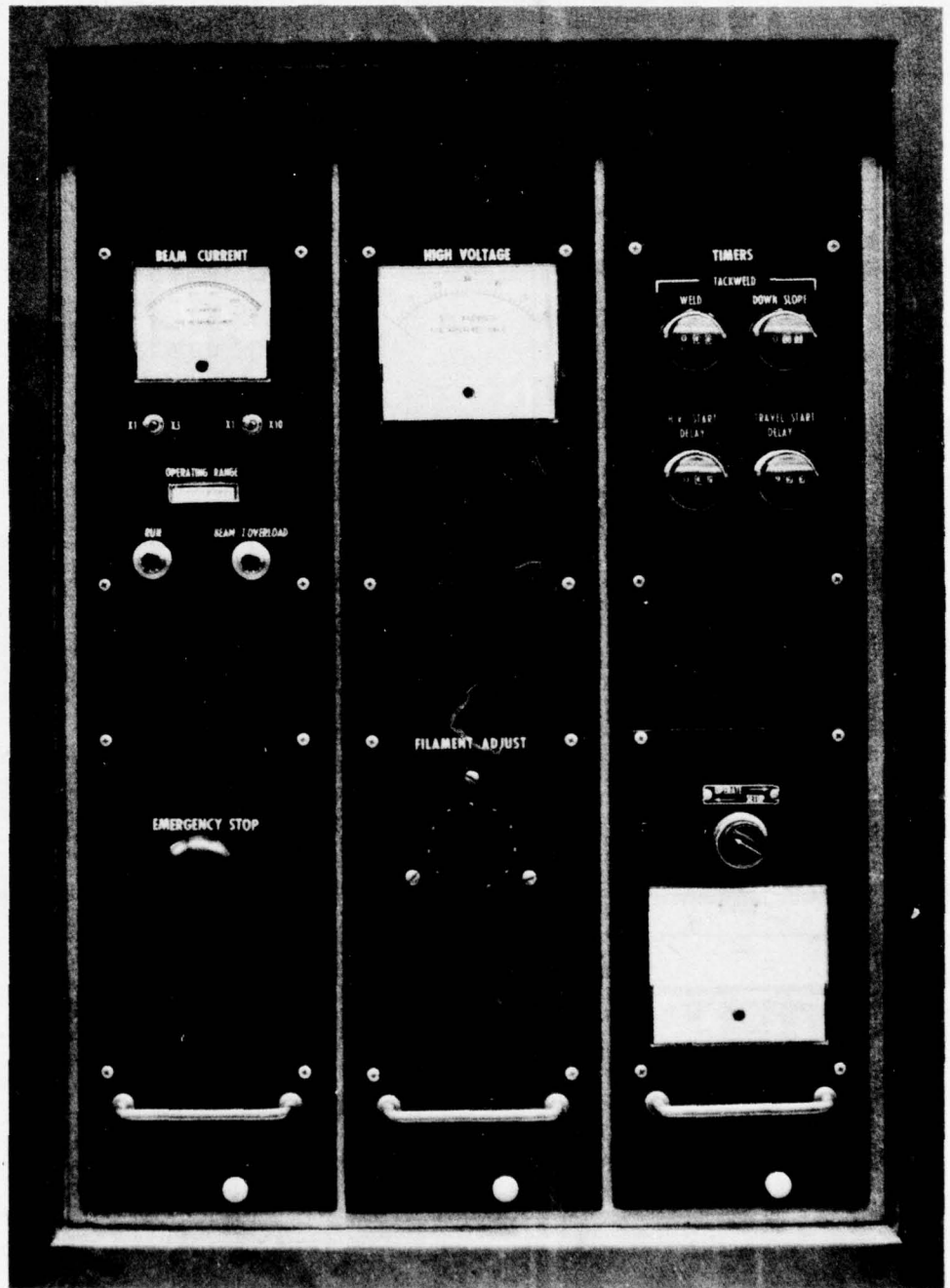

Figure 10 Control Panel for Beam Constant-Current and Overload Control Units

TABLE 1. VERIFICATION OF CONSTANT-CURRENT AND OVERLOAD CONTROL UNITS  
 BY SLIDING SEAL EB WELDS IN ONE-HALF-INCH-THICK 2014-T651  
 ALUMINUM ALLOY PLATE

| WELD NO.  | BEAM VOLTAGE, KV | BEAM CURRENT, MA | FOCUS CURRENT, AMP | TRAVEL SPEED, IN./MIN. | RESULTS/COMMENTS  |
|-----------|------------------|------------------|--------------------|------------------------|---|
| SSEB-EC-1 | 40               | 150              | 6.45               | 40                     | Meter readings constant   |
| SSEB-EC-2 | 40               | 150              | 6.45               | 40                     | Meter readings constant   |
| SSEB-EC-3 | 40               | 150              | 6.45               | 40                     | Surface 0.130" wide, underfill 0.025"; penetration 0.125" wide, 0.063 deep                              |
| SSEB-EC-4 | 40               | 150              | 6.45               | 40                     | Surface 0.130" wide, 0.025", underfill; penetration 0.120" wide 0.066" deep                             |
| SSEB-EC-5 | 40               | 150              | 6.45               | 40                     | Fluctuating beam current, arc out after 12" of weld, weld varied.                                       |
| SSEB-EC-6 | 40               | 150              | 6.45               | 40                     | Surface 0.145" wide; 0.020" underfill; penetration 0.100" wide, 0.060" deep                             |
| SSEB-EC-7 | 40               | 150              | 6.45               | 40                     | Surface 0.130"-0.147" wide, 0.010"-0.025" underfill; penetration 0.115"-0.125" wide, 0.058"-0.066" deep |
| SSEB-EC-8 | 40               | 150              | 6.45               | 40                     | Similar to previous welds   |

- c. Weld Current Slope Techniques - Parameter development was conducted in the "hard" vacuum equipment to establish weld settings for welding 1/2-inch-thick 2024-T351 aluminum alloy and to evaluate sloping techniques for tapered close-out of the weld seam. Table 2 lists the weld parameters and current settings varied in this effort to develop a uniform weld and establish weld current slope settings. Weld current sloping from weld settings down to 50 milliamperes at weld-stop were not completely successful in eliminating crater cracks in the weld stop. Table 2 also lists weld settings used on the sliding seal EB setup using the short, flat-plate welding fixture. These welds, made at a higher heat input, established parameters for the cylinder weldment and showed that considerable effort was required to develop current sloping techniques to close-out a weld seam. Since this effort was directed toward eliminating surface and internal defects in welds, no further work was done. The main efforts of the cylinder welding tasks were to demonstrate simplified weld tooling and vacuum requirements, and show welding feasibility. Weld parameters used for butt welds 1 and 2 were used for the cylinder weld.

#### D. AREA LAYOUT FOR WELDING FIXTURES

A floor plan of the SSEB welding facility (Figure 11) showing the proposed locations of the flat-plate welding area (34-foot-long table) and the cylinder welding area (12-foot-diameter tank) relative to that of the SSEB welder were analyzed and approved by Facilities Engineering. The overall weight and weight-per-square-inch of each fixture were also furnished for floor-loading calculations.

The special-shapes welding fixture and the preheat-steel welding fixture were set-up on the existing weld table shown in Figure 11. Facilities Engineering approved the installation of these fixtures and of a 220-volt/100-ampere service line for the existing weld table. This electrical service was required for preheating of the steel plates in the preheat-steel welding fixture.

#### E. MATERIAL PROCUREMENT AND WELD COUPON FABRICATION

Purchase orders were issued for the necessary one-inch-thick 2014-T651 aluminum alloy plate and one-inch-thick Ti-6Al-4V titanium alloy plate. The 2014-T651 aluminum alloy plate was purchased per Specification AMS 4029E. The Ti-6Al-4V titanium alloy plate was purchased per Grumman Specification GM 3103A which is more restrictive than Specification MIL-T-9046F in that it specifies a more uniform microstructure, ultrasonic testing and a 5,000 psi higher yield strength. These requirements insured that titanium plate of a more uniform quality was obtained. Weld coupon fabrication began after the material was received and accepted by Inspection. Since 1/2-inch-thick 2014-T351 aluminum plate required for the cylinder fabrication was not available; a similar 2000 series aluminum alloy was substituted for the cylinder weld. The receipt and acceptance requirements for these materials are summarized in Table 3. The chemical analysis of the as-received materials are shown in Table 4.

TABLE 2. PARAMETER DEVELOPMENT FOR 1/2-INCH-THICK 2024-T351 ALUMINUM ALLOY PLATE FOR CYLINDER WELDING APPLICATION

| WELD NO.      | BEAM VOLTAGE KV | BEAM CURRENT MA | FOCUS CURRENT AMPERES | TRAVEL SPEED IN./MIN. | HEAT INPUT KJ/IN. | RESULTS     |       |                 |           |       |       |
|---------------|-----------------|-----------------|-----------------------|-----------------------|-------------------|-------------|-------|-----------------|-----------|-------|-------|
|               |                 |                 |                       |                       |                   | TOP SURFACE |       |                 | UNDERBEAD |       |       |
|               |                 |                 |                       |                       |                   | SHAPE       | WIDTH | UNDER-FILL      | SHAPE     | WIDTH | DEPTH |
| BOP # 1       | 40              | 125             | 4.85                  | 40                    | 7.5               | Uniform     | .125" | .020"           | Uniform   | .130" | .050" |
| BOP # 2       | 40              | 115             | 4.85                  | 40                    | 6.9               | Uniform     | .130" | .020"           | Uniform   | .100" | .050" |
| BOP # 3       | 40              | 115             | 4.90                  | 40                    | 6.9               | Uniform     | .140" | .020"           | Uniform   | .100" | .060" |
| BOP # 4       | 40              | 100             | 4.95                  | 40                    | 6.0               | Fair        | .125" | Flush           | Narrow    | .060" | .040" |
| BOP # 5       | 40              | 105             | 4.90                  | 40                    | 6.3               | Uniform     | .150" | .020"           | Uniform   | .090" | .060" |
| Butt Weld # 1 | 40              | 105             | 4.85                  | 45                    | 5.6               | Fair        | .110" | .030"           | Uniform   | .060" | .085" |
| Butt Weld # 2 | 40              | 100             | 4.85                  | 40                    | 6.0               | Uniform     | .115" | .015"<br>Crocon | Poor      | .080" | .020" |
| Butt Weld # 3 | 40              | 100             | 4.85                  | 40                    | 6.0               | Uniform     | .130" | .020"           | Uniform   | .080" | .060" |
| SSEB WELDS    |                 |                 |                       |                       |                   |             |       |                 |           |       |       |
| Butt Weld # 1 | 40              | 150             | 6.45                  | 40                    | 9.0               | Narrow      | .070" | .020"           | Uneven    | .100" | .040" |
| Butt Weld # 2 | 40              | 150             | 6.45                  | 40                    | 9.0               | Narrow      | .080" | .010"           | Uneven    | .090" | .040" |
| Butt Weld # 3 | 40              | 175             | 6.45                  | 40                    | 10.5              | Narrow      | .080" | .020"           | Uneven    | .100" | .040" |

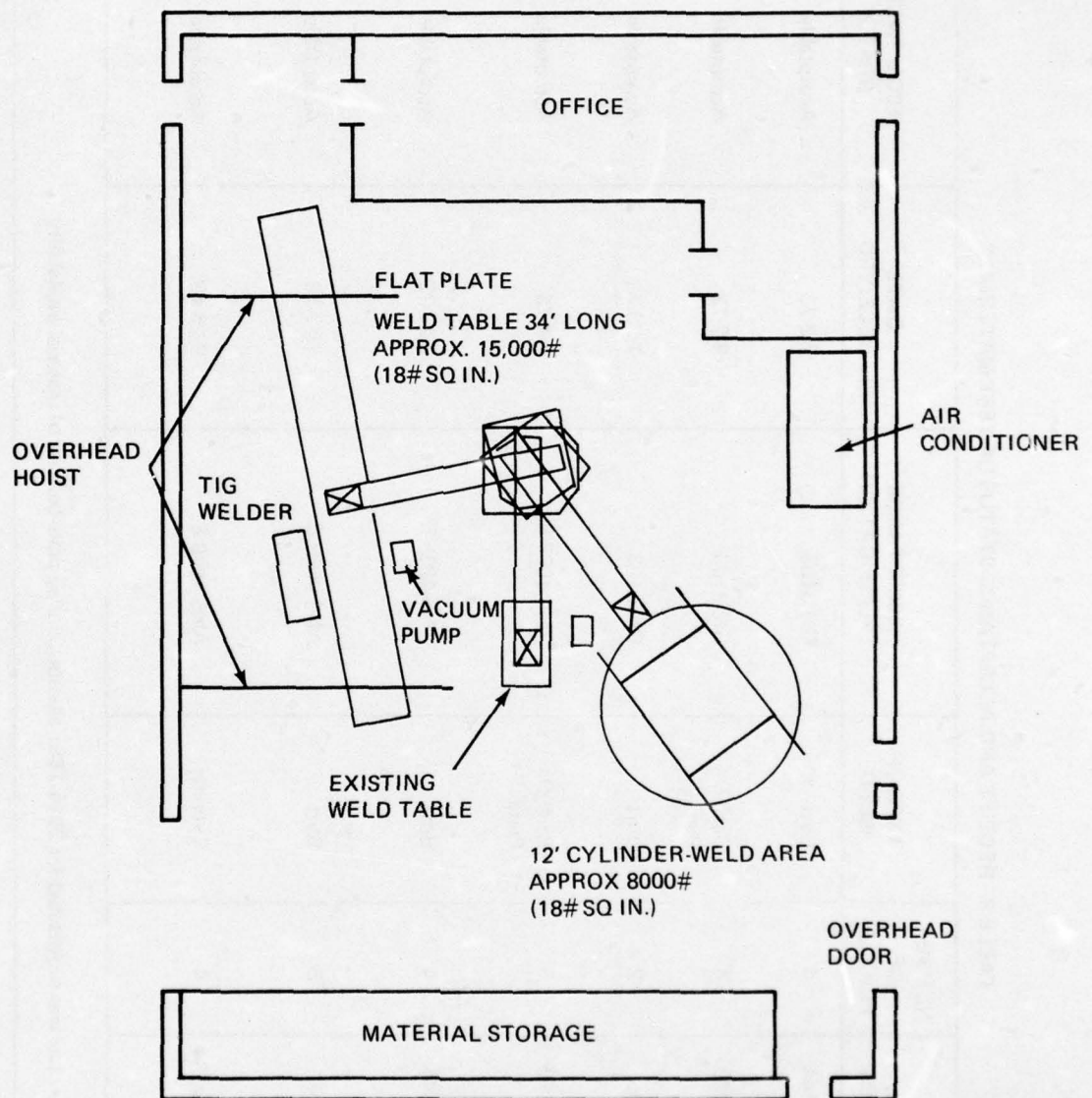

Figure 11 Sliding-Seal Electron-Beam Welding Area Layout

TABLE 3. RECEIPT AND ACCEPTANCE STATUS OF TEST MATERIALS

| MATERIAL                     | SIZE, INCHES | NUMBER OF PLATES | TYPE OF WELD  | ACCEPTANCE SPECIFICATION | DATE RECEIVED | ACCEPTANCE STATUS |
|------------------------------|--------------|------------------|---------------|--------------------------|---------------|-------------------|
| Ti-6Al-4V<br>Titanium Alloy  | 1x12x144     | 4                | Butt          | GM 3103                  | 8-2-73        | Acceptable        |
| Ti-6Al-4V<br>Titanium Alloy  | 1x24x180     | 4                | Bead-On-Plate | GM 3103                  | 8-2-73        | Acceptable        |
| Ti-6Al-4V<br>Titanium Alloy  | 1x48x96      | 2                | Butt          | GM 3103                  | 7-23-73       | Acceptable        |
| 2014-T651<br>Aluminum Alloy  | 1x24x180     | 6                | Bead-On-Plate | AMS 4029 E               | 9-4-73        | Acceptable        |
| 2014-T651<br>Aluminum Alloy  | 1x12x144     | 4                | Butt          | AMS 4029 E               | 8-29-73       | Acceptable        |
| 2014-T651<br>Aluminum Alloy  | 1x48x48      | 3                | Butt          | AMS 4029 E               | 10-2-73       | Acceptable        |
| 2024-T351*<br>Aluminum Alloy | 1/2x48x144   | 4                | Cylinder      | AMS 4029 E               | 9-26-73       | Acceptable        |

\*2024-T351 aluminum alloy plate was substituted for 2014-T651 aluminum alloy plate because of material availability

TABLE 4. CHEMICAL ANALYSES OF AS-RECEIVED MATERIALS

| MATERIAL  | SPECIFICATION NO. | ALLOYING CONSTITUENT, PERCENT |                      |                  |
|---|-------------------|-------------------------------|----------------------|------------------|
|   |                   | ELEMENT                       | SPECIFIC REQUIREMENT | GRUMMAN ANALYSES |
| 2014-T651<br>Aluminum<br>Alloy<br>1-Inch-Thick<br>Plate | AMS 4029 E        | Al                            | Remainder            | Remainder        |
|   |                   | Si                            | 0.5 - 1.2            | 1.00             |
|   |                   | Cu                            | 3.9 - 5.0            | 4.18             |
|   |                   | Fe                            | 0.7 max.             | 0.31             |
|   |                   | Mn                            | 0.4 - 1.2            | 0.82             |
|   |                   | Mg                            | 0.2 - 0.8            | 0.65             |
|   |                   | Cr                            | 0.10 max.            | 0.02             |
|   |                   | Zn                            | 0.25 max.            | 0.10             |
| Ti-6Al-4V<br>Titanium<br>Alloy<br>1-Inch-Thick<br>Plate | GM 3103 A         | Ti                            | Remainder            | Remainder        |
|   |                   | Al                            | 5.50 - 6.75          | 6.42             |
|   |                   | V                             | 3.50 - 4.50          | 4.19             |
|   |                   | Fe                            | 0.30 max.            | 0.15             |
|   |                   | C                             | 0.08 max.            | 0.03             |
|   |                   | N                             | 0.05 max.            | 0.0258           |
|   |                   | O <sub>2</sub>                | 0.20 max.            | 0.1132           |
|   |                   | H                             | 0.015 max.           | 0.0064           |
| HY 130<br>Alloy Steel<br>1-Inch-Thick<br>Plate          | Mil-S-16216 G     | Ni                            | 4.75 - 5.25          | 05.0             |
|   |                   | Cr                            | 0.40 - 0.70          | 0.56             |
|   |                   | C                             | 0.12                 | 0.12             |
|   |                   | Mo                            | 0.30 - 0.65          | 0.51             |
|   |                   | V                             | 0.05 - 0.10          | 0.07             |
|   |                   | Si                            | 0.20 - 0.35          | 0.27             |
|   |                   | Cu                            | 0.25 max.            | 0.07             |
|   |                   | P                             | 0.010                | 0.008            |
|   |                   | Mn                            | 0.60 - 0.90          | 0.74             |
|   |                   | S                             | 0.010                | 0.008            |
|   |                   | Ti                            | 0.02 max             | 0.002            |
| Fe  | Remainder         | Remainder                     |                      |                  |
| D6AC<br>Alloy Steel<br>1-Inch-Thick<br>Plate            | GM1013            | C                             | 0.42 - 0.48          | 0.44             |
|   |                   | Mn                            | 0.60 - 0.90          | 0.68             |
|   |                   | Si                            | 0.15 - 0.30          | 0.14             |
|   |                   | P                             | 0.010 max.           | 0.009            |
|   |                   | S                             | 0.010 max.           | 0.004            |
|   |                   | Cr                            | 0.90 - 1.20          | 0.96             |
|   |                   | Mo                            | 0.90 - 1.10          | 0.91             |
|   |                   | V                             | 0.07 - 0.15          | 0.09             |
|   |                   | Ni                            | 0.40 - 0.70          | 0.47             |
|   |                   | Fe                            | Remainder            | Remainder        |

TABLE 4. CHEMICAL ANALYSES OF AS-RECEIVED MATERIALS (CONT)

| MATERIAL  | SPECIFICATION NO. | ALLOYING CONSTITUENT, PERCENT |                      |                  |
|---|-------------------|-------------------------------|----------------------|------------------|
|   |                   | ELEMENT                       | SPECIFIC REQUIREMENT | GRUMMAN ANALYSES |
| 2024-T351<br>Aluminum<br>Alloy<br>1/2-Inch-Thick<br>Plate | AMS 4037 H        | Al                            |                      | Remainder        |
|   |                   | Si                            | 0.50 max             | .143             |
|   |                   | Cu                            | 3.8 - 4.9            | 4.365            |
|   |                   | Fe                            | 0.50                 | .275             |
|   |                   | Mn                            | 0.30 - 0.9           | .610             |
|   |                   | Mg                            | 1.2 - 1.8            | 1.465            |
|   |                   | Cr                            | 0.10                 | .022             |
|   |                   | Zn                            | 0.25                 | .060             |

F. SEAL LIFE/WEAR EVALUATION PLANNING

A seal life/wear study was conducted with nine sets of sliding seals on long weldments made at high beam power to obtain an accurate indication of seal life. Bead-on-plate welds and butt welds were made keeping the energy inputs at the same level as those developed for optimum SSEB welding parameters in the previous Air Force program. Electron-beam welding conditions and energy inputs are listed in Table 5. After wear conditions of the seals was determined, the seals were visually examined and photographed to obtain a permanent record. Seal-life data were tabulated to formulate a more realistic estimate for seal-life in welding aluminum and titanium alloys.

TABLE 5. SEAL WEAR STUDY PROGRAM

| SEAL SET NUMBER | MATERIAL                    | THICKNESS, INCH | WELD CONDITION | ENERGY INPUT, KILOJOULES/INCH | MINIMUM SEAL WEAR LENGTH (APPROXIMATE), FEET |
|-----------------|-----------------------------|-----------------|----------------|-------------------------------|--|
| 1-2             | 2014-T651<br>Alum. Alloy    | 1               | Bead on plate  | 13.5                          | 100  |
| 3-4             | 2014-T651<br>Alum. Alloy    | 1               | Butt weld      | 13.5                          | 50   |
| 5               | T-6A1-4V<br>Titanium Alloy  | 1               | Bead on plate  | 19.8                          | 11   |
| 6               | Ti-6A1-4V<br>Titanium Alloy | 0.300           | Bead on plate  | 9.0                           | 65   |
| 7-8-9           | Ti-6A1-4V<br>Titanium Alloy | 1               | Butt weld      | 19.8                          | 36   |

### SECTION III

#### PHASE II - TOOL FABRICATION, INSTALLATION AND WELDING PROGRAM

##### A. WORK AREAS

The Phase II tool fabrication, installation and welding program included the following work areas:

- Weld tool fabrication and welding tasks on flat plate, cylinder, special shapes and preheat steel welding fixtures.
- Equipment head modifications
- Seal life/wear evaluation
- Filler wire additions

##### B. WELD TOOL FABRICATION AND WELDING TASKS

###### 1. Flat Plate Welding Fixture

Fabrication and installation of this fixture was accomplished by completing several tasks.

- a. Material Hardware Procurement - Upon completion of the detailed prints for the Flat Plate Welding Fixture, the following items were purchased and used to fabricate the fixture:
  - Thomson solid "60" cast-hardened and ground roundways
  - Thomson single and dual roundway bearing and mounting blocks
  - Boston gear rack, spur gear, sprocket, bearing flange and thrust bearing
  - Gleason powertrak type "45"
  - Tygon vacuum hose (1-inch I.D. x 2-inch O.D.)
  - Buna "n" O-ring Cord stock
  - Hot-rolled steel plate (one piece - 4 x 12-1/2 x 240 inches)

The following additional items were required for the fixture driving mechanism:

- 2-hp permanent magnet motor
- D-4 Ohio gear reducer assembly
- No. 40 chain with 1/2-inch pitch and assorted sprockets and couplings
- 1-hp speed controller, 10-turn potentiometer, remote control start and stop jog station and voltage follower.

Other miscellaneous items required for the fabrication of the weld fixture such as nuts, bolts, washers, dowel pins, bushings and additional hot-roll steel plate were also obtained.

- b. Welding and Machining of Fixture - The six support stanchions for the weld tables were fabricated and two inspection-checking-fixture (ICF) tables were prepared for use as the support tables.

The 4 x 12 1/2 x 240-inch, hot-rolled steel bar, which constituted the center section of the welding fixture, was machined to form the vacuum area for the backup bars and the O-ring seals. The box structure was welded to the machined bar. The bolt holes for the holddown bars were drilled and tapped on the top surface of the fixture. After the welded assembly was stress relieved at 1100°F for six hours, the bottom and top surfaces of the fixture were machined flat and parallel to close tolerances. The O-ring grooves were N/C machined on the top surface. The fixture was then steam-cleaned and painted.

- c. Installation in SSEB Welding Area - Installation of the Flat Plate Welding Fixture began with the bolting of the welded stanchions to the ICF support tables, spotting the stanchions in place on the floor and leveling the tables (Figure 12). The Thomson series "60" case-hardened and ground rails were assembled on the tables and adjusted for height setting. The gear rack and roundway bearings were mounted on the base of the fixture which, in turn, was mounted on the support rails on the weld table assembly (Figure 13). The vacuum fittings, copper lines, flexible tygon tubing and powertrak were then installed on the weld fixture.

The O-rings were fabricated and placed in the grooves on the fixture. A flat plate was placed over the O-rings and vacuum leak check of the fixture was performed to locate any leaks in the assembly. The vacuum setup was capable of evacuating the backup bar area to 20-30 microns in several minutes. This was the vacuum level that was used on the previous SSEB welding setup.

A two-horse-power motor/gear box arrangement (Figure 14) was mounted on the welding support tables and connected to the flat-plate welding fixture with a chain drive. A 220-volt electric service for the motor was installed. A junction box (Figure 15), which connects the boom drive (X-axis) controls and the table drive for the welding fixture, was mounted on the control station containing a digital pot speed control, jog switch, run switch, and a forward-reverse direction switch.

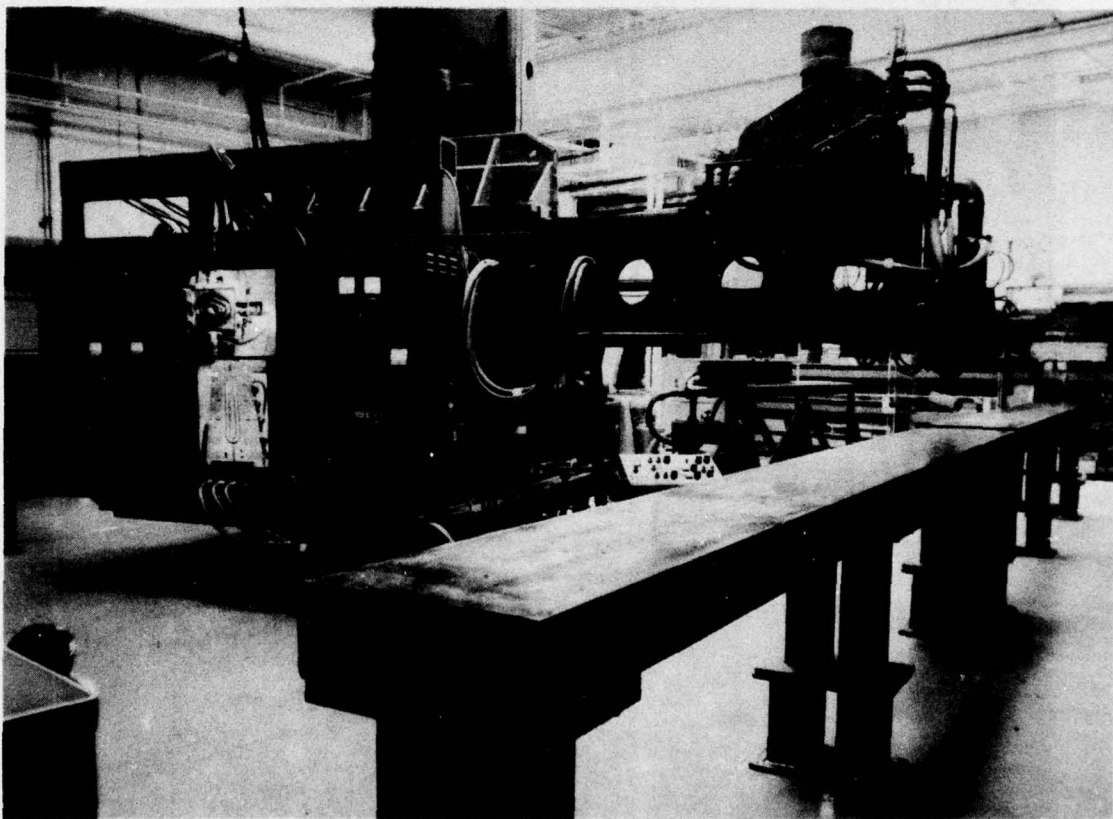

Figure 12 ICF Support Tables for Flat Plate Welding Fixture

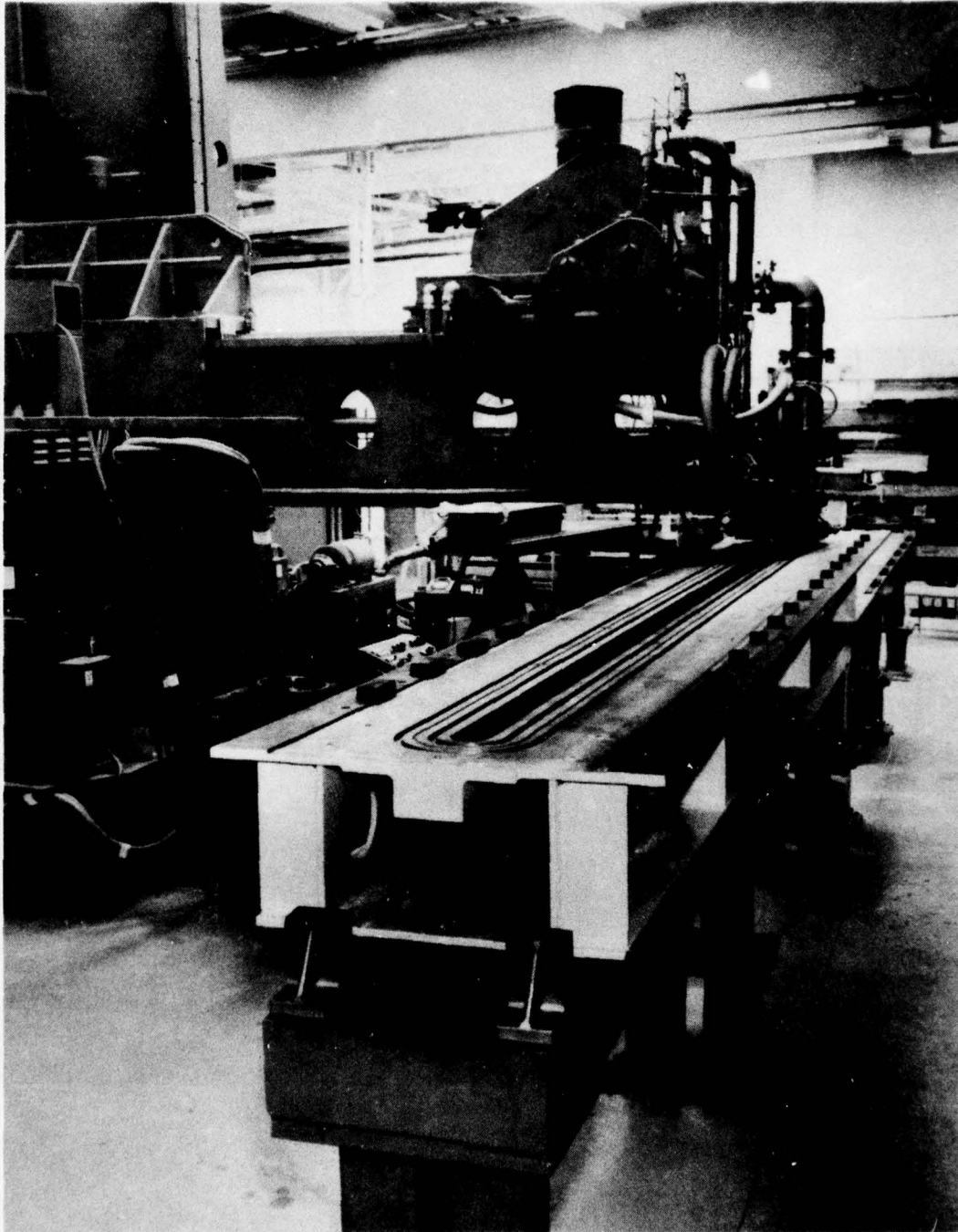

Figure 13 Flat Plate Welding Fixture Mounted on Table Assembly

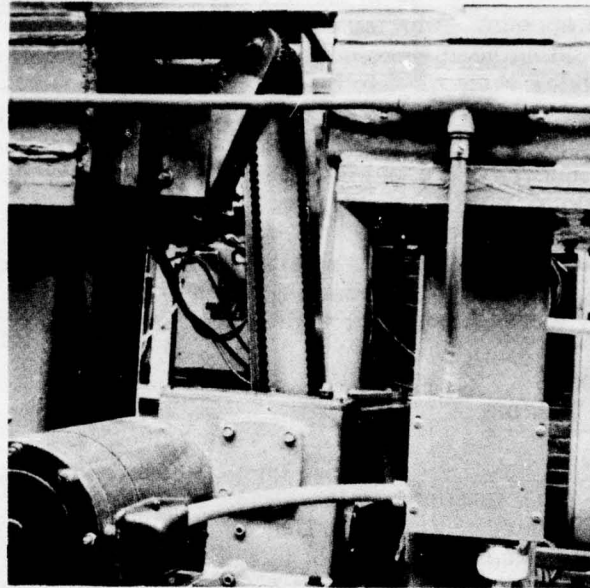

Figure 14 Two-Horsepower Motor and Gear Box Arrangement for the Flat Plate Welding Fixture

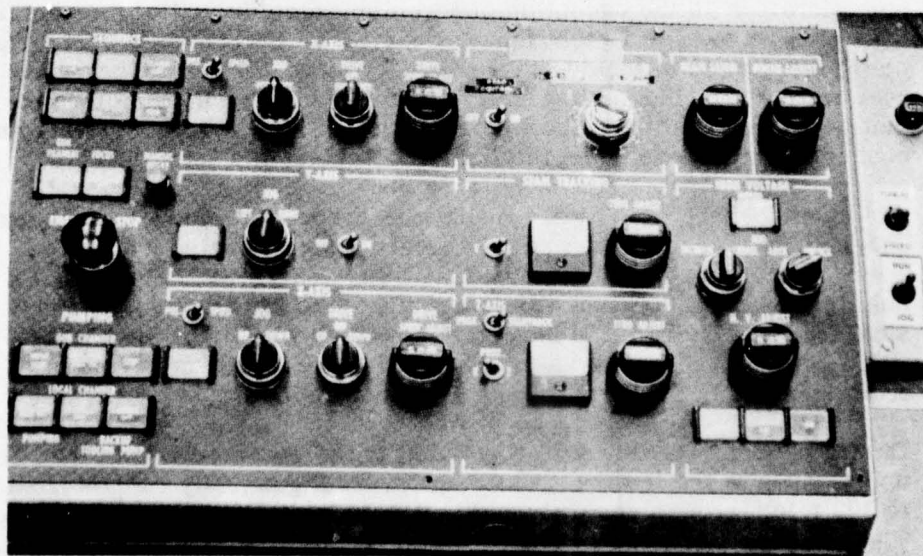

Figure 15 Control Station-Junction Box for the Flat Plate Welding Fixture

#### d. Check-Out and Verification of Tooling Concept for Flat Plate Welding Fixture

The travel speeds for the welding fixture were calibrated to give a direct, digital pot-meter reading. Precise readings were obtained over a 20 to 80-ipm range of travel speeds. Since the welding speeds involved were to be in 40 to 60-ipm range, no attempt was made to calibrate the equipment over a wider range of travel speeds. Another check of the travel speeds was made after the boom and welding head were positioned for welding and the welding head area was held under vacuum. No changes in travel speeds were observed with the addition of the welding head to the plate surface. No problems were encountered at the high end of the travel speed range (50 to 60-ipm). An operational check of the welding capability of the fixture was made by bead-on-plate welding of aluminum plate.

Operational use of the SSEB welder for welding long flat plates and short test panels was proven by its ability to produce acceptable weldments. The welding tasks described below were carried out to demonstrate fixture and SSEB welder capabilities.

##### (1) Aluminum Plate Welding

- (a) Bead-On-Plate Welds - Five bead-on-plate welds were made on 1-inch-thick, 2014-T651 aluminum alloy plate using the parameters shown in Table 6. The maximum length that could be welded was 13 1/2 feet. During welding, the vacuum level in the head remained constant while the table vacuum level increased to 80-90 microns. This was attributed to outgassing of the material and the use of long vacuum lines to evacuate the table area. Weldments 2, 3 and 4 were made using the parameters developed previously for one-inch-thick, 2014-T651 aluminum alloy plate.

Thirty-seven bead-on-plate welds were made on 1-inch-thick aluminum plate. With the exception of three short welds, all of the remaining welds were over 13 feet long. Four, 2-foot-wide by 15-foot-long plates were used in making these welds. Since the backup bar area was two inches wide, nine welds were made on each plate before the plate was removed from the welding fixture. Welding parameters and heat inputs were varied on the first six weldments.

Weldments 6 through 35 were made with the same welding parameters and heat inputs; seal life-wear data were also generated with these weldments (see d(3), Aluminum Seal Life/Wear). Surface bead characteristics and penetration were the same for all welds. The surface beads were 0.130 inch wide and flush with 0.010 inch under-fill. Penetration width was 0.140 to 0.145 inch while depth ranged from 0.090 to 0.100-inch. Figure 16 shows views of a typical weld.

During welding, an increase was noted in the vacuum level in the backup bar area of the fixture. The vacuum level generally ranged from 80 to 100 microns with several welds made at levels of 130 to 150 microns. The head vacuum level increased to a maximum of 10 to 20 microns. This increase in vacuum level was considered acceptable for aluminum welds, since weld appearance was not affected in any way.

TABLE 6. INITIAL SSEB WELDING PARAMETERS AND RESULTS FOR BEAD-ON-PLATE WELDS MADE IN ONE-INCH-THICK, 2014-T651 ALUMINUM ALLOY PLATE USING THE FLAT PLATE WELDING FIXTURE

| WELD NO. | BEAM VOLTAGE, KV | BEAM CURRENT, MA | FOCUS CURRENT, AMP | TRAVEL SPEED, IN./MIN | HEAT INPUT, KJ/IN. | RESULTS/COMMENTS   |
|----------|------------------|------------------|--------------------|-----------------------|--------------------|--|
| 1        | 50               | 270              | 6.40               | 40                    | 20.25              | Weld length 159 in.; weld surface uniform; 0.125" wide, flush crown 0.010"-0.015" deep (0.030" spots); penetration 0.140"-0.145" wide, 0.090"-0.100" deep - tear on edges of seal, 1" long on both sides   |
| 2        | 50               | 270              | 6.40               | 60                    | 13.50              | Weld length 160 in.; weld surface uniform 0.125" wide, flush 0.010"-0.015" deep; penetration similar to weld No. 1 - no seal change  |
| 3        | 50               | 270              | 6.40               | 60                    | 13.50              | Weld length 162 in.; weld similar to welds No. 1 and 2 - slight wear in center of seal   |
| 4*       | 50               | 270              | 6.35               | 60                    | 13.50              | Weld length 160 in.; weld surface uniform 0.130" wide - more uniform width, 0.010" underfill; penetration same as previous welds - tear on inner seal  |
| 5        | 45               | 200<br>225       | 6.35<br>6.40       | 40                    | 13.50<br>15.18     | Weld length 158 in.; varied focus setting 6.30 to 6.40 amp, weld narrowed, high crown (incomplete penetration); increased beam current to 225 ma, and focus to 6.35 amp - weld widened 0.130" wide similar to previous weld - tear approx. 1" long on inner seal |

\*Bead-on-plate welds 6 to 35 used these weld parameters for the seal life/wear study.

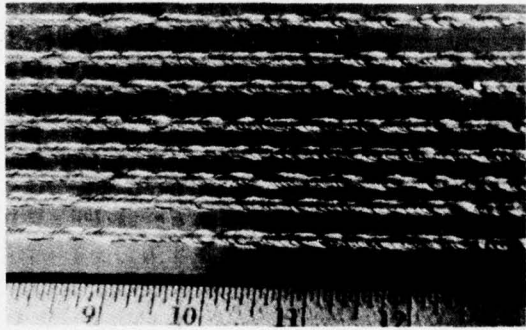

A. TOP SURFACE

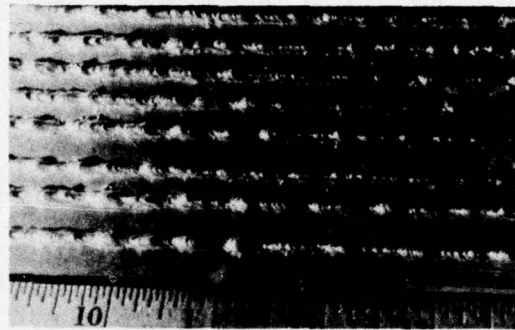

B. BOTTOM SURFACE

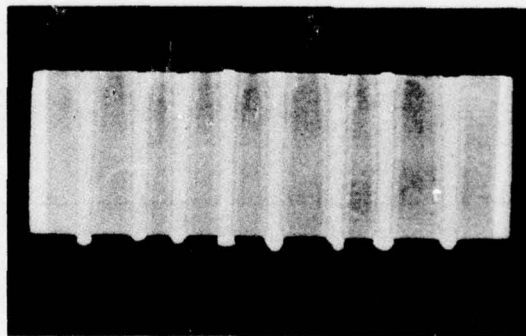

C. CROSS SECTION

Figure 16 Views of Bead-on-Plate Weld Made on Flat Plate Welding Fixture

- (b) Long-Length Butt Welds - Two 12-ft long aluminum butt welds were made using the Flat-Plate Welding Fixture. The welding parameters were those developed for bead-on-plate welding (beam voltage - 50 kilovolts, beam current - 270 milliamperes, focus current - 6.35 amperes, travel speed - 60 inches per minute, and heat input - 13.5 kilojoules per inch). An arc-out occurred in the first weld after 28 1/2 inches had been welded. A restart behind the arc-out area was attempted, but an increase in the head vacuum level shut down the welding operation after three inches had been welded. The arc-out area and stop-hole of the short weld were satisfactorily repaired by GTA welding. Welding was resumed and continued for 99 inches to the end tab. Vacuum levels rose to 30 microns in the weld head and to 750 microns in the weld table. Examination of the weld showed slight beam defocusing in three spots and fairly uniform surface appearance over the last three feet of weldment. A check of the penetration showed weld misalignment of about 0.060 in. at the arc-out area. These operating difficulties are discussed in Section III B.1.d of this report. It was decided to remove the weld penetration and reweld the entire plate. No problems were encountered during the second welding operation. Vacuum levels in the head and table held at 20 and 200 microns, respectively. The resultant weld was flush (0.005 in. crown) with minimal underfill (0.005 in.) and 0.0170 in. wide. Penetration was uniform (0.130-0.135 in. width and 0.060-0.070 in. depth). Figure 17 is a view of a 12 foot aluminum butt weld set up on the flat plate weld fixture.

The second 12-ft long aluminum butt weld plate was set up for welding in the same manner as the first plate. Witness lines were scribed on the plate to check alignment. The same welding parameters were used. Vacuum levels were held at 15 and 140 microns in the head and table, respectively. The welding operation was similar to that performed previously with the bead-on-plate welds. The resultant weld was slightly narrower and had a little deeper penetration than the first 12-ft long butt weld. Examination of the witness lines showed that the weld had moved 0.060 in. from the weld seam on both the top and bottom surfaces. This was attributed to an equipment situation which was corrected (see d.2, Weld Seam Alignment). The plate was then rewelded; seam alignment was precisely maintained (within 0.002 inch). The surface bead was 0.145 in. wide with 0.010 to 0.015 in. underfill and had a 0.125-in. wide by 0.090 to 0.100-in. deep penetration.

- (c) Short Test Panel Welds - A cover plate was set up on the Flat-Plate Welding Fixture (Figure 18) so that the 2-ft long welds required for the test program could be made. Eight butt weldments were fabricated on one-inch thick, 2014-T651 aluminum alloy plate. Welding parameters and test results are summarized in Table 7. Completion of these weldments satisfied the aluminum requirements for this program. Tensile specimens were cut from the base-metal and welded areas of Weldment No. 4 and tested. Data obtained are presented in Tables 8 and 9.

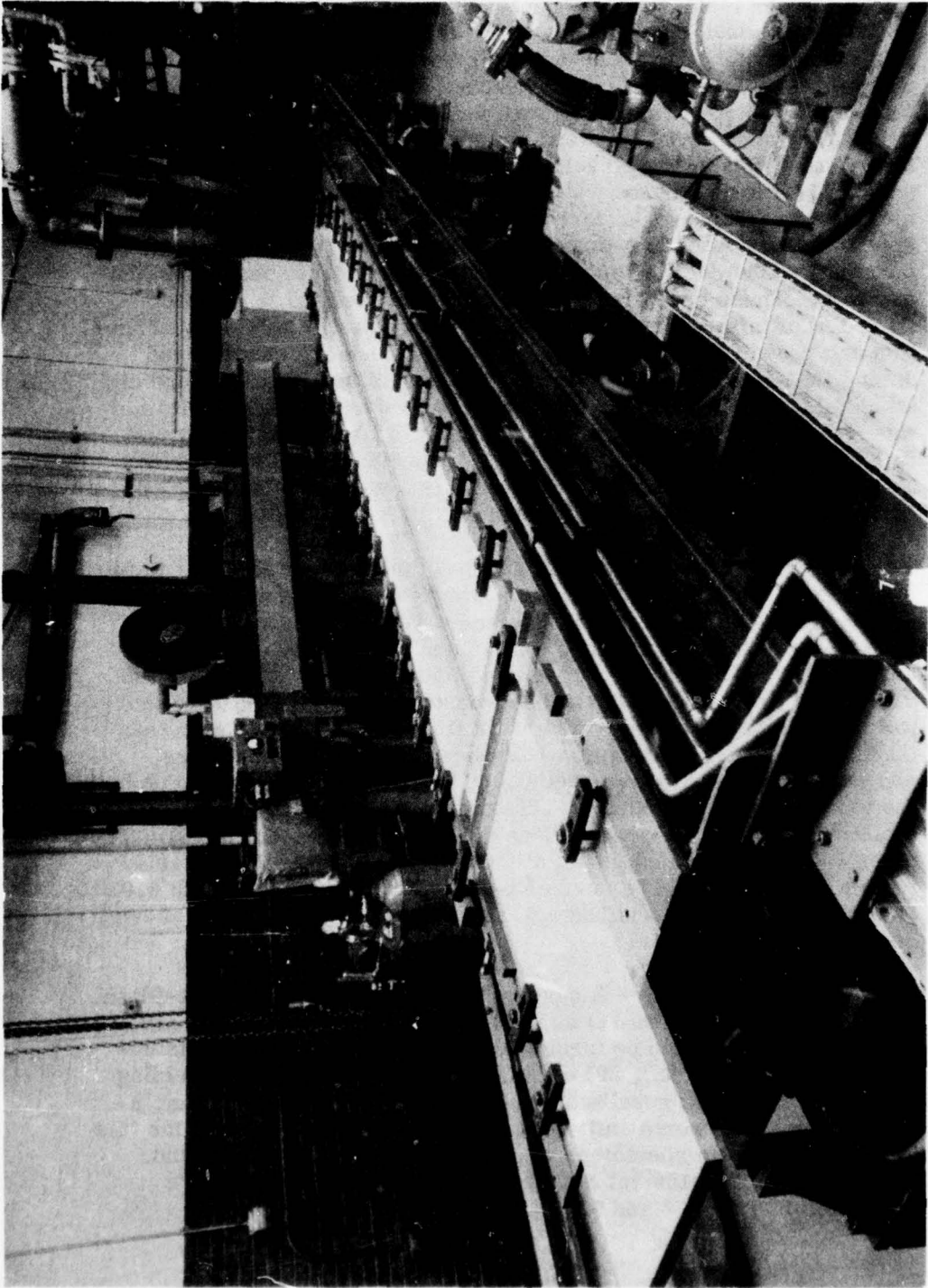

Figure 17 12-Foot-Long Aluminum Butt Weld Setup

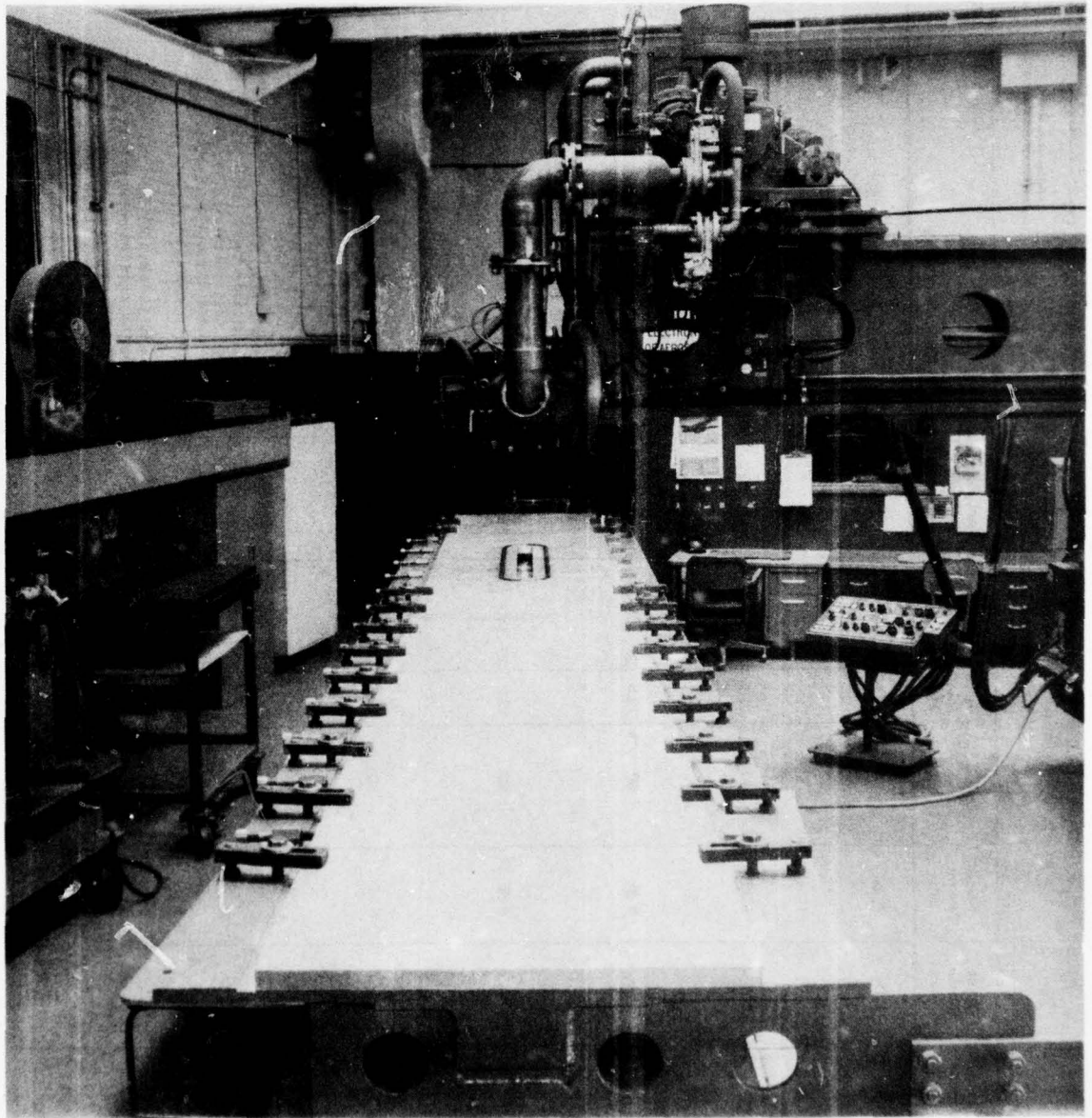

Figure 18 Aluminum Cover Plate on Flat Plate Welding Fixture

TABLE 7. SSEB BUTT WELDMENTS ON ONE-INCH-THICK 2014-T651 ALUMINUM ALLOY  
 PLATE (24-INCH-LONG TEST WELDS USING COVER PLATE ON  
 FLAT PLATE WELDING FIXTURE)

| Weld No. | Beam Voltage, kv | Beam Current, ma | Focus Current, amp | Travel Speed, in./min | Heat Input, kj/in. | Vacuum, microns Hg. |                   | Results/Comments  |
|----------|------------------|------------------|--------------------|-----------------------|--------------------|---------------------|-------------------|---|
|          |                  |                  |                    |                       |                    | Table min-max       | SSEB Head min-max |   |
| 1        | 50               | 270              | 6.35               | 60                    | 13.5               | 25 - 140            | 0 - 20            | Very uniform weld, surface, .165" wide, .020" - .025" crown, no underfill; penetration .110" wide, .075" deep - slight seal wear, center wear on inner seal from weld bead, .003" deflection X-Ray EBF No. 986 - linear porosity.     |
| 2        | 50               | 270              | 6.35               | 60                    | 13.5               | 30 - 150            | 0 - 20            | Uniform weld, surface, .150" wide, .020" - .025" underfill, flush crown; penetration .090" - .100" wide, .075" deep - no change in seal wear, .005" deflection. X-Ray EBF No. 986—linear porosity.                                    |
| 3        | 50               | 270              | 6.35               | 60                    | 13.5               | 27 - 150            | 0 - 30            | Uniform weld, surface, .150" wide, .020" underfill, slight crown; penetration .115" - .120" wide, .080" - .095" deep - no change in seal wear, .008" deflection. X-Ray EBF No. 988 - satisfactory - (no porosity).                    |
| 4        | 50               | 270              | 6.35               | 60                    | 13.5               | 29 - 140            | 0 - 20            | Uniform weld, surface, .150" wide, .020" underfill, slight crown; penetration .120" wide, .090" deep - no seal wear, .005" deflection. X-Ray EBF No. 988 - clean (1 void .250", 1 void .030"); tensile specimens made from this weld. |
| 5        | 50               | 270              | 6.35               | 60                    | 13.5               | 14 - 120            | 0 - 20            | Uniform weld, surface, .150" wide, .020" underfill, slight crown; penetration .110" wide, .090" deep - no change in seal wear, .008" deflection. X-Ray EBF No. 989 - satisfactory - (no porosity).                                    |
| 6        | 50               | 270              | 6.35               | 60                    | 13.5               | 30 - 140            | 0 - 35            | Uniform weld, surface, .155" wide, .020" underfill, slight crown; penetration .115" wide, .090" deep - no change in seal wear, .015" deflection. X-Ray EBF No. 989 - satisfactory - (no porosity).                                    |
| 7        | 50               | 270              | 6.35               | 60                    | 13.5               | 15 - 120            | 0 - 45            | Uniform weld, surface, .155" wide, .020" - .025" underfill, slight crown; penetration .115" wide, .090" deep - no seal wear, .002" deflection. X-Ray EBF No. 989 - satisfactory - (no porosity).                                      |
| 8        | 50               | 270              | 6.35               | 60                    | 13.5               | 30 - 90             | 0 - 25            | Weld defocused, high crown.   |

TABLE 8. TENSILE PROPERTIES OF ONE-INCH-THICK 2014-T651 ALUMINUM ALLOY BASE METAL

| SPECIMEN NUMBER | ULTIMATE TENSILE STRENGTH, KSI | YIELD TENSILE STRENGTH, KSI | ELONGATION IN TWO IN., % |
|-----------------|--------------------------------|-----------------------------|--------------------------|
| 100 AB-1        | 72.3                           | 67.2                        | 8.0                      |
| 100 AB-2        | 72.5                           | 67.2                        | 8.0                      |
| 100 AB-3        | 72.6                           | 67.7                        | 7.0                      |
| Avg Value       | 72.5                           | 67.4                        | 7.6                      |

TABLE 9. TENSILE PROPERTIES OF SSEB WELDED ONE-INCH-THICK 2014-T651 ALUMINUM ALLOY (SQUARE BUTT JOINT, FLAT POSITION, AS WELDED CONDITION)

| SPECIMEN NUMBER | ULTIMATE TENSILE STRENGTH, IN. | YIELD TENSILE STRENGTH, IN. | ELONGATION IN TWO IN., % | FAILURE LOCATION |
|-----------------|--------------------------------|-----------------------------|--------------------------|------------------|
| 100 ATW-1       | 57.8                           | 52.4                        | 1.0                      | Fusion Line      |
| 100 ATW-2       | 58.0                           | 51.9                        | 2.0                      | Fusion Line      |
| 100 ATW-3       | 59.5                           | 52.4                        | 1.5                      | Fusion Line      |
| 100 ATW-4       | 57.5                           | 52.4                        | 1.0                      | Fusion Line      |
| 100 ATW-5       | 58.6                           | 52.4                        | 1.0                      | Fusion Line      |
| 100 ATW-C       | 56.5                           | 52.7                        | 1.0                      | Fusion Line      |
| Avg Value       | 58.0                           | 52.4                        | 1.25                     |                  |
| Avg Value *     | 57.1                           | 48.2                        | 2.3                      |                  |

\* Previous SSEB Weld Program Data For One-Inch-Thick 2014-T651 Aluminum Alloy Plate

- (d) Aluminum Welding Evaluation - The evaluation of the aluminum weldments was by visual, metallographic, and radiographic examination and tensile testing. Weld visual appearance and radiographic results are noted in Table 7. Figure 19 is a Macro section of one of the weldments. All weldments had a uniform bead shape and consistently uniform penetration. Radiographic evaluation shows that test weldments No. 3 thru No. 8 were acceptable per GSS 6202. Tensile testing showed that the welded specimens exhibited 80% tensile efficiency for ultimate and 78% tensile efficiency for yield stresses. The tensile data listed in Tables 8 and 9 attained slightly higher results than the weldments tested on the previous SSEB weld program. It is concluded from these results that the flat plate weld fixture can produce uniform welds that are free from defects and have mechanical properties equal to standard EB welds.

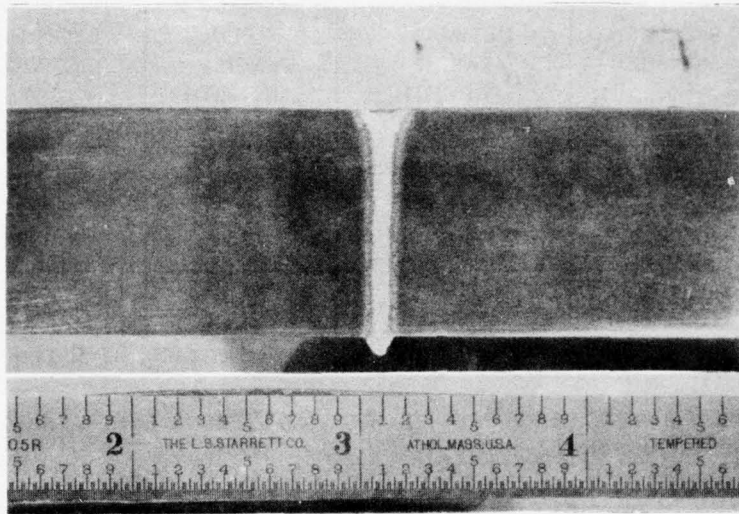

Figure 19 Macro-Section of 2014-T651 Aluminum Butt Weld (1.5 X MAG)

(2) Weld Seam Alignment

In making the first two aluminum butt welds, the weld seam became misaligned about 0.060 inch from the weld. This was thought to be due to inaccurate movement of the welding fixture along rails installed on the tables. Laser optical measuring equipment was set up to check the travel of the welding fixture (Figure 20). Three targets were mounted on the welding fixture and aligned with the laser beam. Readout meters connected to the targets gave calibrated measurements of beam deflection while the welding fixture was moved back and forth on the roundways. Readings were taken with and without the welding head in place under vacuum and with and without Powertrak and vacuum lines connected. The maximum fixture deflection measured was 0.005-0.006 inch.

The boom and welding head were then monitored with the fixture set up for welding. It was found that the boom moved 0.060 inch during the first two feet of travel. This was attributed to backlash on the boom's gear-rack and drive-gear mechanism. The boom was free to move back until the gear-rack rested tightly against the drive gear. A dial indicator was mounted on the boom at this position and set against the vertical column of the SSEB welder. This made it possible for the welding operator to monitor boom deflection. A series of tests showed that if the boom was jogged forward in increments of about 0.050 inch to the weld seam the drive-gear remained in close contact with the gear-rack. This gave minimal or no boom deflection when the fixture was moved for welding. This procedure was incorporated in the welding sequence of operations. A dial indicator is being used to monitor boom motion on all welds. Boom deflections ranging from zero to 0.006 inch were observed on subsequent welding operations. Since a boom deflection of 0.015 inch is considered sufficient to cause weld seam misalignment, the present procedure should insure precise alignment of the weld seam.

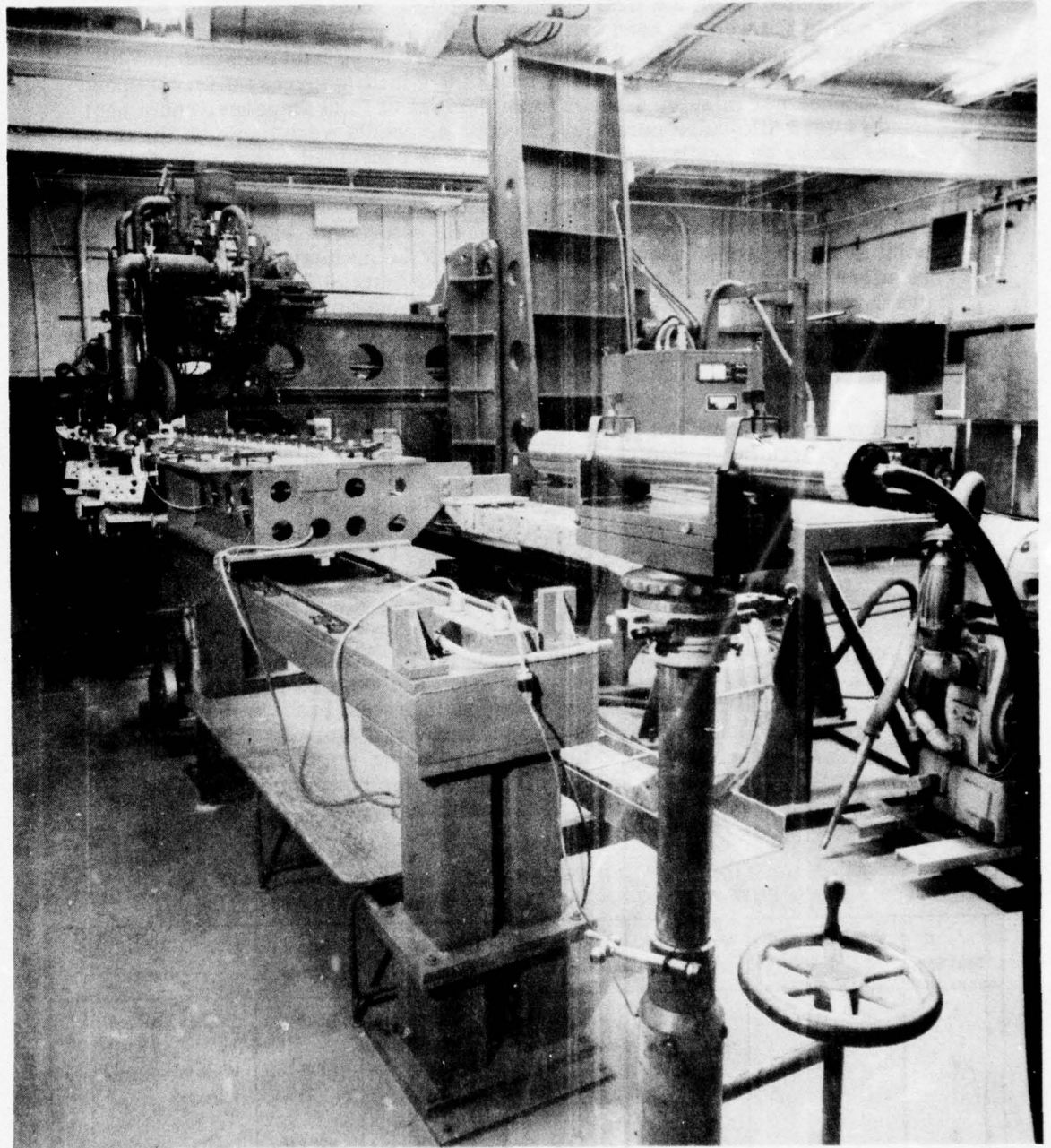

Figure 20 Laser Optical Measuring Arrangement

### (3) Aluminum Seal Life/Wear Evaluation

This study was initiated with bead-on-plate welding on one-inch-thick aluminum plate. After completion of the welding parameter and fixture evaluation studies on the first aluminum plate, a new set of sliding seals was installed in the welding head and used for the remainder of the welding tests on the other three plates. Welding parameters were held constant at a beam voltage of 50 kilovolts, a beam current of 270 milliamperes, a travel speed of 60 inches per minute, a beam focus current of 6.35 amperes, and a heat input of 13.5 kilojoules per inch. Twenty-six welds were made on the three plates before the available plate material was consumed. Since 350 feet of weldment were made using the same set of seals without any appreciable degree of wear over the last ten weldments, it was estimated that at least 700 to 1,000 feet of weldment could be made before the seals were to the point at which proper vacuum levels could not be maintained. The program requirement was to weld 150 feet of seal wear tests. The seals were photographed to obtain a permanent record of the amount of wear that had occurred. The welding parameters used, the length of each weldment, the vacuum level obtained, and the amount of seal wear were recorded for each of the 26 welds that were made.

Welding studies could not be conducted at the slower (30-ipm travel speed) because of welding difficulties at travel speeds below 40 inches per minute. The drive system limitations that was noticed during installation and calibration of the motor drive cause irregular weld beads and undue wear on the seals. Since favorable results were attained at higher travel speeds (60 imp), all seal wear welding was done at that setting.

Table 10 is a summary of the aluminum welding tests performed on the flat plate weld fixture. Figure 21 shows a new set of sliding seals installed on the SSEB weld head. Figure 22 shows the sliding seals that were used for 26 bead-on-plate welds before being replaced. The wear on this set of seals (set #2) was caused by sliding over the previous weld beads which wore a wide area on the seals. In contrast to this wear, Figure 23 sliding seal set #3, which was used for butt welding only, received slight wear on the center of the seals. This was caused by sliding over the hot weld bead during welding and is a more general type of sliding seal wear.

TABLE 10. SLIDING SEAL LIFE/WEAR RESULTS FOR BEAD-ON-PLATE AND BUTT WELDS ON 2014-T651 ALUMINUM ALLOY PLATE

| Seal Set | Welded Length Feet* | Number of Welds | Heat Input KJ/In. | Travel Speed In./Min. | Type of Welds | Results                      |
|----------|---------------------|-----------------|-------------------|-----------------------|---------------|------------------------------|
| 1        | 81                  | 7               | 15.0-13.5         | 40-60                 | BOP           | Slight wear                  |
| 2        | 350                 | 26              | 13.5              | 60                    | BOP           | Wide wear caused by abrasion |
| 3        | 41                  | 6               | 13.5              | 60                    | 12' Butt      | Center notch wear            |
| 4        | 43                  | 10              | 13.5              | 60                    | 2' Butt       | Center notch wear            |

\* All (4) Seal Sets Were Capable of Vacuum Sealing for Further Welding.

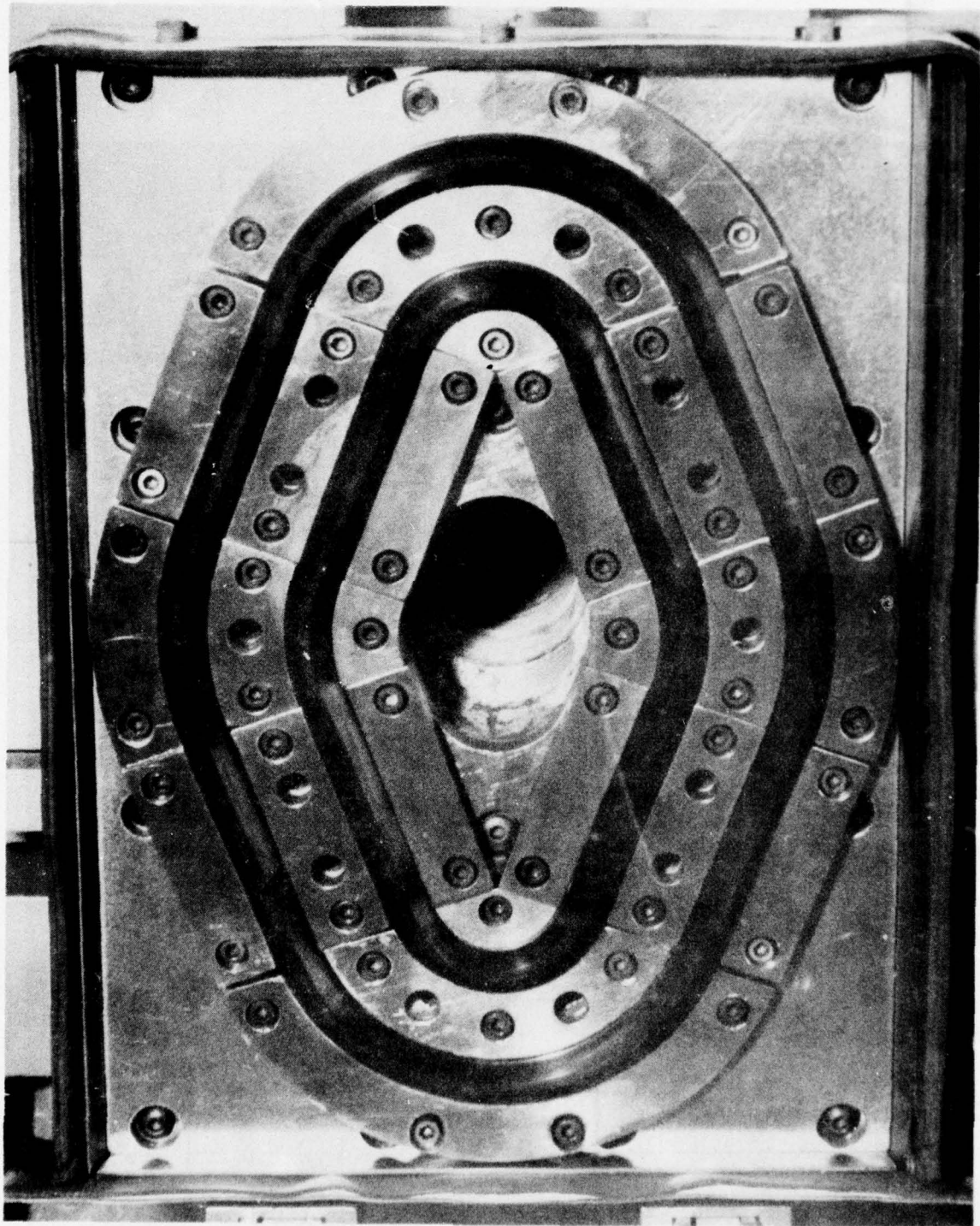

Figure 21 New Sliding Seals on SSEB Weld Head



Figure 22 Sliding Seal Set No. 2 - Wear Caused by Repeated Aluminum Bead-on-Plate Welding

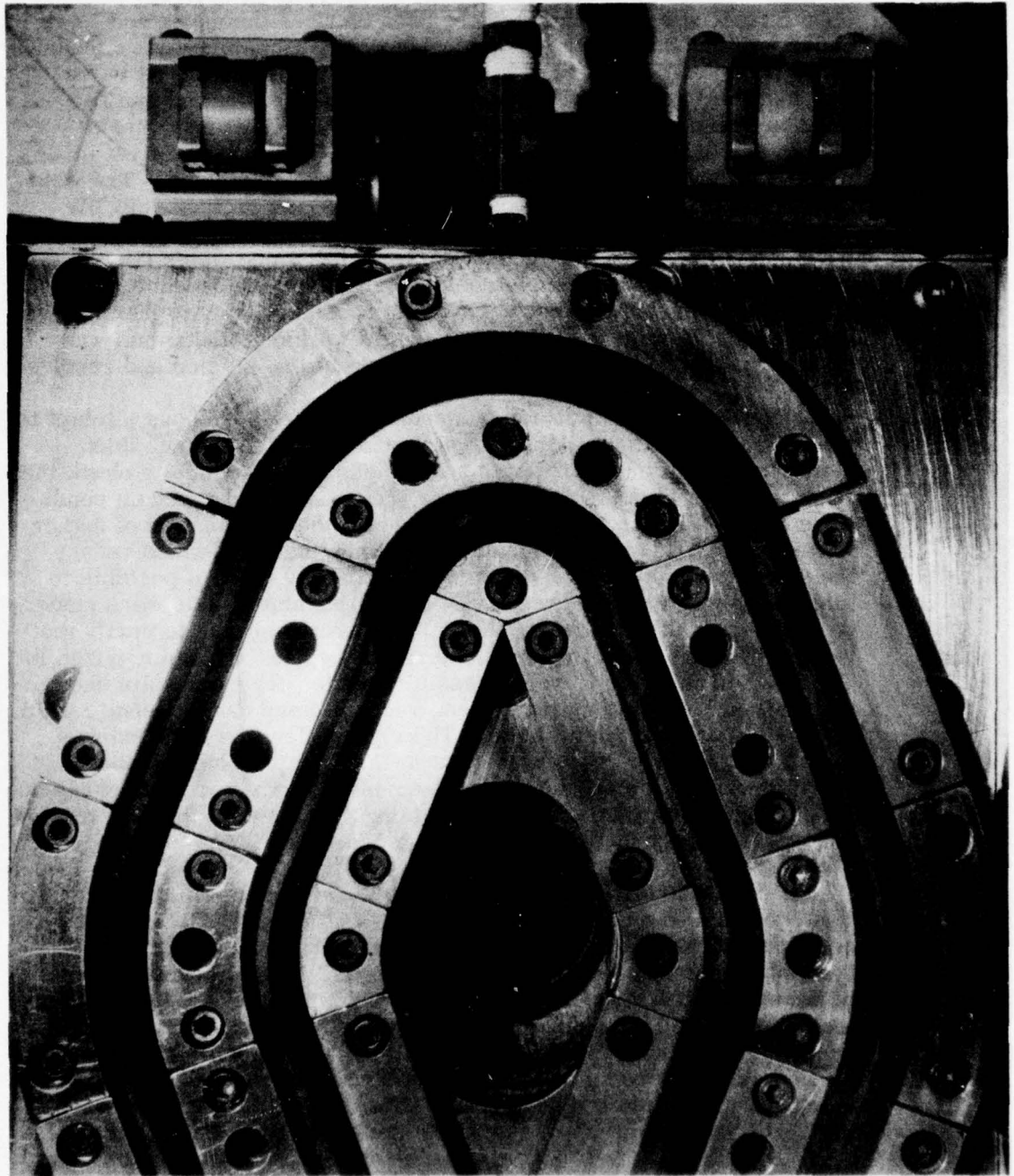

Figure 23 Sliding Seal Set No. 3 - Wear Caused by Long Butt  
Welding on Aluminum Plate

(4) Titanium Plate Welding

- (a) Bead-on-Plate Welds - Weldability of one-inch-thick titanium plate was also checked on the Flat-Plate Welding Fixture. Vacuum levels rose sharply during welding (to 180-200 microns in the backup bar area and to 80 microns in the head), automatically shutting down the welding operation. The vacuum gage in the head area is set to shut off the tapered valve located in the area between the upper and lower heads, which contains the electron-beam gun to maintain the vacuum level at  $10^{-4}$  millimeters of mercury. The tapered shut-off valve was installed as a safety measure to prevent exposing the gun filament to sharp increases in vacuum which would have detrimental effects on both the filament and the gun. As a result, the first three welds attempted were short-- only 7, 9 and 18 inches long. The welding parameters used were those developed on the previous SSEBW program. By increasing the pumping time and welding on the end of the fixture closest to the vacuum ports, three more welds (19, 32, and 46 inches long) were made before automatic shutdown occurred. The vacuum level in the backup area increased sharply to 200 microns and then to 500 microns on the last weld. Welding of titanium was discontinued so that the vacuum problem could be studied and resolved.

After considering the problems encountered in the previous attempt to weld 0.880-inch thick titanium plate, one of the 0.880-inch thick plates was chemically milled to a thickness of 0.300 inch to check the effect of lower heat inputs and higher travel speeds on vacuum conditions during welding. It was theorized that the combination of higher travel speeds, lower heat inputs and thinner material would reduce the amount of material vaporization and thereby make it possible to maintain lower vacuum levels. Two bead-on-plate welds were made on 0.880-inch thick titanium plate at high travel speeds to verify the proposed theory. Welding parameters and results are summarized in Table 11. The welds were successfully made. These results show that the existing welding fixture and vacuum setup can be used to weld 0.880-inch thick titanium plate. The vacuum level in the head was maintained at 50 microns while that in the table was held at about 300 microns. Five full length bead-on-plate welds were then made on 0.300-inch thick titanium plate. Welding parameters, vacuum levels and weld bead characteristics are also presented in Table 11.

Welding of .880-inch thick titanium plate was resumed. Difficulty was encountered with the vacuum systems at this time. Eight bead-on-plate welds were made on 0.880-inch thick titanium plate at vacuum levels between 300 and 500 microns. A helium leak check of the entire welding vacuum setup was made in an effort to pin-point leaks in the vacuum equipment. Leaks were found in the diffusion pump, vacuum hose and flange seals on the mechanical pumps. Appropriate repairs were made to eliminate these leaks in the SSEB equipment. In order to increase vacuum efficiency of the Flat-Plate Welding Fixture, a cold trap was added to the base of the welding fixture.

TABLE 11. SSEB BEAD-ON-PLATE WELDMENTS ON Ti-6Al-4V TITANIUM ALLOY PLATE  
(PARAMETER DEVELOPMENT AND SEAL LIFE-WEAR STUDY)

| Mat'l<br>Thick,<br>in. | Weld<br>No. | Beam<br>Voltage,<br>kv | Beam<br>Current,<br>mil | Focus<br>Current,<br>amp | Travel<br>Speed,<br>in/min | Heat<br>Input,<br>kj/in | Vacuum Level,<br>microns |      | Weld<br>Length,<br>in | Results/Comments  |
|------------------------|-------------|------------------------|-------------------------|--------------------------|----------------------------|-------------------------|--------------------------|------|-----------------------|---|
|                        |             |                        |                         |                          |                            |                         | Table                    | Head |                       |   |
| 0.880                  | 7           | 50                     | 300                     | 6.35                     | 50                         | 18.0                    | 300                      | 50   | 60                    | Weld uniform, no underfill, .135" wide surface, .050" crown; penetration .090" wide, .030" deep; burn on seals from weld crossover; penetration could be deeper.                                    |
| 0.880                  | 8           | 50                     | 330                     | 6.35                     | 50                         | 19.8                    | 300                      | 45   | 83                    | Weld very uniform, surface .160" wide, .040" crown; penetration .085" wide, .060" deep; tear on inner seal - 1" long, .090" deep; slight wear on outer seal.  |
| 0.300                  | 1           | 45                     | 225                     | 6.40                     | 50                         | 12.15                   | 450                      | 30   | 150                   | Weld flat uniform, surface .120" wide, .010" crown, .003" underfill; penetration .100" wide, .015" deep; seal wear (2) spots 1/8" wide, 1/16" deep on inner and outer seals.                        |
| 0.300                  | 2           | 45                     | 200                     | 6.40                     | 50                         | 10.8                    | 450                      | 30   | 156                   | Weld similar to weld #1; seal wear increased to 1/2" wide - 1/8" deep on inner seal.  |
| 0.300                  | 3           | 45                     | 200                     | 6.40                     | 60                         | 9.0                     | 750-400                  | 30   | 156                   | Weld similar to previous welds; seal wear 3/4" wide - 1/8" deep on inner seal, 1" wide - 1/16" deep on outer seal. Weld made in opposite direction; vac. high-750, dropped to 400 for most of weld. |
| 0.300                  | 4           | 45                     | 200                     | 6.40                     | 60                         | 9.0                     | 400                      | 50   | 152                   | Weld similar to previous welds; seals worn smooth - used for laser checkout of table alignment - slight wear on inner seal from weld crossover.   |
| 0.300                  | 5           | 45                     | 200                     | 6.40                     | 60                         | 9.0                     | 750-500                  | 30   | 155                   | Weld similar to previous welds; no change in seal wear.   |

The cold trap modification increased the pumping capability and shortened the time required to evacuate the underside of the weld plate. The original vacuum setup required a pump-down time of 15 minutes to reach a 30-micron vacuum level. With the new addition to the system, it was possible to attain a 5 to 10-micron level in two to three minutes.

- (b) Long-Length Butt Welds - Two long-length butt welds were made on the Flat Plate Welding Fixture. The first butt weld was 144 inches long; the second weld was stopped after 78 inches of weld were made because of a seal wear problem. The 12-ft long plates were fixtured on the Flat Plate Welding Fixture for the GTA seal-pass operation. A Linde HW-25-GTA welding torch was mounted on the SSEB boom and used for the welding setup. Adequate support, clamping and aligning of the plates could not be properly maintained, because this fixture was not designed for GTA welding. Since full access to the weld plate surface was required for the sliding seals and head assembly, close-in support tooling or clamps could not be used to restrain the plates during the GTA sealing pass and subsequent SSEB weld. Rigid support tooling located as close as possible to the weld seam was necessary for all welding operations.

The first attempt at a 12-foot long SSEB butt weld was ended after 14-inches of weld were made. Vacuum problems were the cause of the short weld and halted several other attempts to continue with the weld. Manual GTA seal welds were made on the short welds. A re-weld of the entire plate was successful in completing a 144-inch long SSEB weld. The weld bead was similar to previous weldments made on the test panels with a uniform surface width of 0.165-inch and 0.010-inch crown. The penetration measured 0.090-inch wide with 0.060 to 0.080-inch drop-through. Radiographic examination of the weldment (EB Film No. 58) revealed numerous voids caused by the start and stop voids of the initial weld attempts.

The second 12-ft long butt weld was made in the same manner as the first weldment. The plates were prepared and GTA seal-pass welded on the Flat Plate Welding Fixture. The SSEB weld was ended after 78 inches of weld were made because of a vacuum loss in the weld head. Investigation of the sliding seals showed that two large pieces were torn off the inner seal. This occurred on the start of the weld and was due to a power surge on the weld start which caused two small titanium beads to form on the weld plate surface. Since it was necessary to replace the sliding seals at this point, no further attempts were made to complete the weld. Upon removal of the weld plate from the fixture, it was found that the machine missed the weld seam. This was attributed to the inadequate weld fixture tooling. No additional welding efforts were made on the flat plate because a newer concept for welding flat plate had been tried and had shown better potential for this particular application.

- (c) Short Test Panel Welds - When appropriate bead-on-plate welds were made to evaluate the new vacuum sealing of the SSEB head and welding fixture, four 24-inch long test panels (SBWT No's 5, 6, 7 and 8) were successfully made on 0.880-inch thick titanium plate. Figure 24 shows a typical view of one of these weldments. All four test panels passed the radiographic requirements for one-inch-thick titanium plate. The last weldment (SBWT No. 8) contained a small (0.030-in. -dia) pore which is acceptable for one-inch thick plate. Six SSEB-welded tensile specimens and three base-metal tensile specimens were machined from Weldment No. 5.
- (d) Titanium Welding Evaluation - Titanium welding efforts were evaluated by visual, metallographic and radiographic examination and by limited tensile testing. Visual and radiographic results for titanium weldments are presented in Tables 11 and 12.

Tensile test results which show 100% tensile efficiency for ultimate and yield and 86% efficiency for elongation are presented in Tables 13 and 14. Although the flat plate fixture was used successfully to weld short length titanium plate, it is not considered the best method for fabrication of long length weldments because of the vacuum problems and the sliding seal wear. The successful welding of the F-14 wing beams at the conclusion of the welding program presents the preferred welding method for titanium welding.

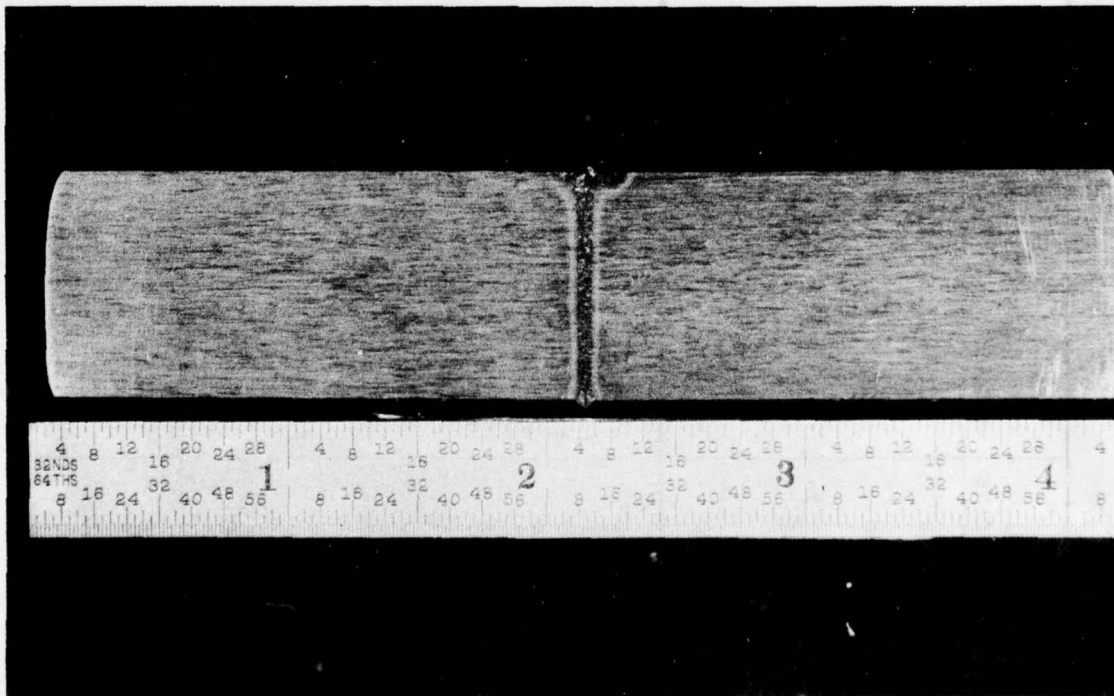

Figure 24 Macro-Section of Ti-6Al-4V Titanium Alloy Butt Weld (1.5 X MAG)

TABLE 12. SSEB BUTT WELD PARAMETERS USED TO WELD 0.880-INCH-THICK  
Ti-6Al-4V TITANIUM ALLOY PLATE

| WELD NO.   | KV<br>KILOVOLTS | MA<br>MILLI<br>AMPERES | FOCUS<br>CURRENT<br>AMPERES | TRAVEL<br>INCHES/<br>MIN. | HEAT<br>INPUT<br>KJ/IN. | RESULTS   |
|------------|-----------------|------------------------|-----------------------------|---------------------------|-------------------------|---|
| WELD No. 1 | 50              | 330                    | 6.35                        | 50                        | 19.8                    | Short weld - 14 inches long   |
| REWELD     | 50              | 330                    | 6.35                        | 50                        | 19.8                    | 144 inches long, uniform bead .165" wide, .040" crown; penetration .080" wide, .060" deep.                                    |
| WELD No. 2 | 50              | 330                    | 6.35                        | 50                        | 19.8                    | Weld 78 inches long, uniform bead, .160" wide, .040" deep; penetration .080" wide, .055" deep.                                |
| SBWT-1     | 50              | 330                    | 6.35                        | 50                        | 19.8                    | Weld 24 inches long, defocused one spot (beam current fluctuation), vacuum held 40-50 microns.                                |
| SBWT-2     | 50              | 330                    | 6.35                        | 50                        | 19.8                    | Weld 8 inches, arc out; reweld end of plate - 5 inch weld - weld defocused equipment problem.                                 |
| SBWT-3     | 50              | 330                    | 6.35                        | 50                        | 19.8                    | Weld made to check equipment (beam current)   |
| SBWT-4     | 50              | 330                    | 6.35                        | 60                        | 19.8                    | Weld 8 1/2 inches long, vacuum problem; restart of weld from opposite end-weld 12 inches.                                     |
| SBWT-5     | 50              | 330                    | 6.35                        | 50                        | 19.8                    | Weld 24 inches long. Uniform weld.  |
| SBWT-6     | 50              | 330                    | 6.35                        | 50                        | 19.8                    | Weld 24 inches long; surface uniform .180" wide, .050" crown; penetration .070" wide, .050" deep, X-Ray EBF # 47 satisfactory |
| SBWT-7     | 50              | 330                    | 6.35                        | 50                        | 19.8                    | Weld 24 inches long; uniform bead; X-Ray EBF # 47 satisfactory, heavy sliding sear wear on plate.                             |
| SBWT-8     | 50              | 330                    | 6.35                        | 50                        | 19.8                    | Weld 6" long - seals worn - replaced seals  |
| SBWT-9     | 50              | 330                    | 6.35                        | 50                        | 19.8                    | Weld 24 inches long, weld uniform, X-Ray EBF # 47 clear, small seam of 8 1/2 inches.  |

TABLE 13. TENSILE PROPERTIES OF 0.880-INCH-THICK Ti-6Al-4V TITANIUM ALLOY BASE METAL (STRESS RELIEVED AFTER MACHINING)

| SPECIMEN | ULTIMATE TENSILE STRENGTH, KSI | YIELD TENSILE STRENGTH, KSI | ELONGATION IN 2 INCHES, % |
|----------|--------------------------------|-----------------------------|---------------------------|
| 100TB-1  | 145.4                          | 141.1                       | 11.5                      |
| 100TB-2  | 145.9                          | 141.7                       | 10.5                      |
| 100TB-3  | 145.7                          | 140.5                       | 11.0                      |
| Average  | 145.7                          | 141.1                       | 11.0                      |

TABLE 14. TENSILE PROPERTIES OF SSB WELDED 0.880-INCH-THICK Ti-6Al-4V TITANIUM ALLOY PLATE (SQUARE BUTT JOINT, FLAT POSITION, STRESS RELIEVED AFTER MACHINING)

| SPECIMEN | ULTIMATE TENSILE STRENGTH, KSI | YIELD TENSILE STRENGTH, KSI | ELONGATION IN 2 INCHES % | FAILURE LOCATION |
|----------|--------------------------------|-----------------------------|--------------------------|------------------|
| 100TTW-1 | 148.5                          | 145.0                       | 9.0                      | Base metal       |
| 100TTW-2 | 147.5                          | 144.2                       | 9.5                      | Base metal       |
| 100TTW-3 | 147.1                          | 143.7                       | 9.5                      | Base metal       |
| 100TTW-4 | 149.5                          | 143.3                       | 9.5                      | Base metal       |
| 100TTW-5 | 148.1                          | 142.0                       | 10.0                     | Base metal       |
| 100TTW-6 | 148.5                          | 144.4                       | 9.5                      | Base metal       |
| Average  | 148.2                          | 143.8                       | 9.5                      |                  |

(5) Titanium Seal Life/Wear Evaluation

Seal life-wear data were also recorded for welds made on 0.880 and 0.300-inch-thick titanium plates. The welding parameters, weld lengths and the seal condition after each weld were recorded. Since large tears (Figure 25) occurred in the seals at the end of each weld made on the 0.880-inch-thick titanium plate, it was estimated that only two or three full-length welds (about 20 to 30 feet) would be made on this thickness. Five welds were made on the 0.300-inch-thick titanium plate before welding was stopped because of sealing difficulties. It was estimated that about 75 to 100 feet of weldment could be made on 0.300-inch-thick titanium plate before the seals were to the point where proper vacuum levels would not be maintained. Because of seal wear and mechanical problems associated with slow table drive speeds, no attempts were made to evaluate titanium welding at lower ipm travel speeds.

Table 15 is a summary of the titanium welding tests performed on the flat plate welding fixture. Sliding seal set #6, Figure 26, shows the results of bead-on-plate welding on 0.300-inch-thick plates. This wear is less extensive than the seal wear on aluminum bead-on-plate because of the less number of welds made on the plate. The heat input was less for the .300-inch-thick plate as compared to the .880-inch-thick weldments; therefore the total welded length was considerably more than the .880-inch-thick plate. Figure 27 sliding seal set #7 shows the damage caused by the weld bead on short butt weld tests. Long butt weld damage to the sliding seals is shown in Figure 28 sliding seal set #9.

TABLE 15. SLIDING SEAL LIFE/WEAR RESULTS FOR BEAD-ON-PLATE AND BUTT WELDS ON Ti-6Al-4V TITANIUM ALLOY PLATE

| Seal Set | Welded Length Feet | Number of Welds | Heat Input KJ/In. | Travel Speed In./Min. | Type of Welds | Results               |
|----------|--------------------|-----------------|-------------------|-----------------------|---------------|-----------------------|
| 5        | 11                 | 6               | 19.8              | 50                    | BOP           | Large area pulled out |
| 6*       | 65                 | 5               | 9.0               | 60                    | BOP           | Medium wear           |
| 7        | 4                  | 3               | 19.8              | 50                    | 2' Butt       | Large area pulled out |
| 8        | 12                 | 5               | 19.8              | 50                    | 2' Butt       | Large area pulled out |
| 9        | 20                 | 2               | 19.8              | 50                    | 12' Butt      | Gross wear            |

\* 0.300-Inch-Thick Plate-Seals Could be Used for Further Welding.

NOTE: For 1.00-Inch-Thick Plate-Seals Were not Capable of Vacuum Sealing for Welding Additional Plate.

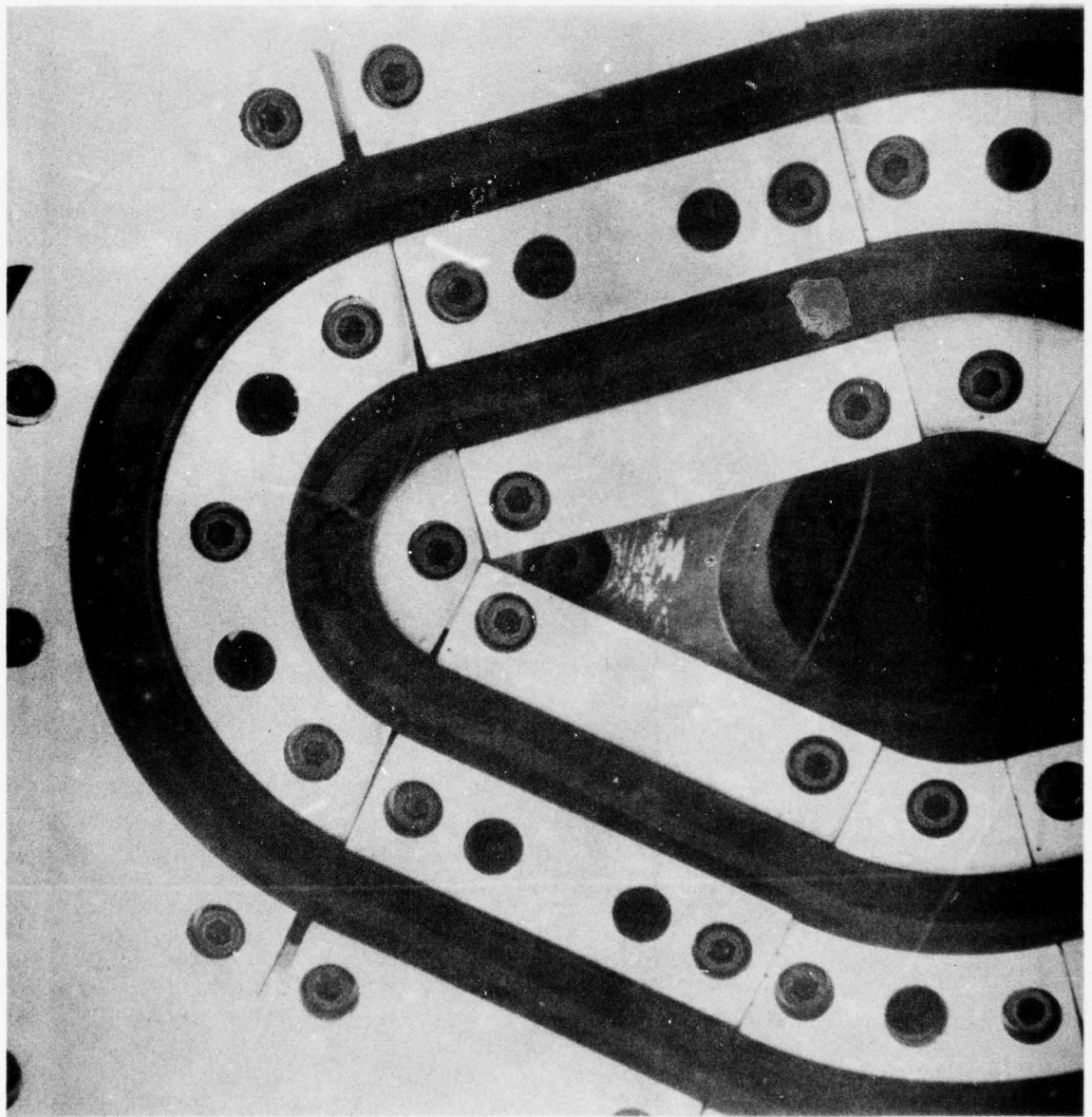

Figure 25 Large Tears in Sliding Seals after Welding Titanium Plate

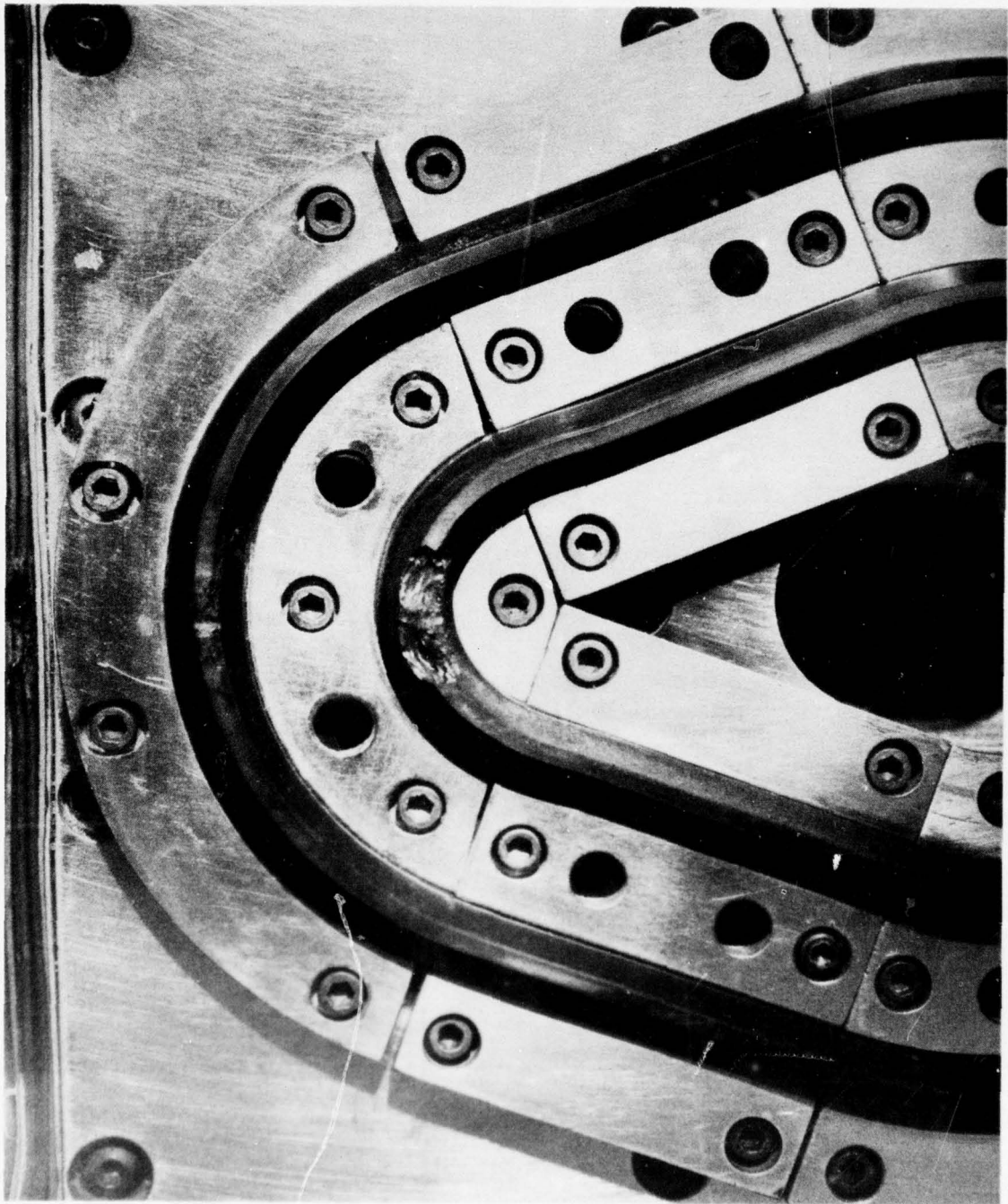

Figure 26 Sliding Seal Set No. 6 - Wear Caused by Repeated  
Titanium Bead-on-Plate Weld

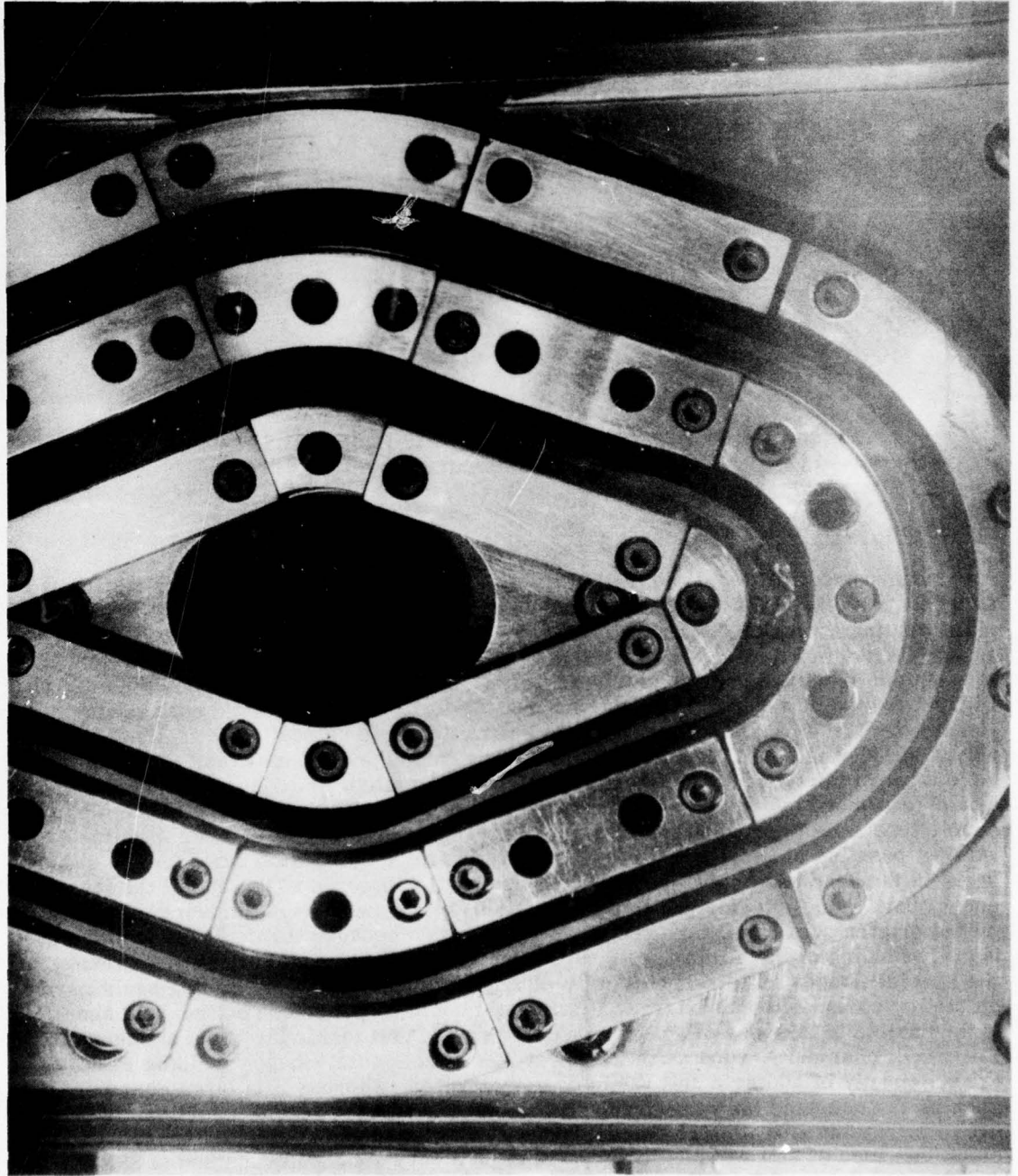

Figure 27 Sliding Seal Set No. 7 - Wear Caused by Short Test Panel  
Butt Welds on Titanium Plate

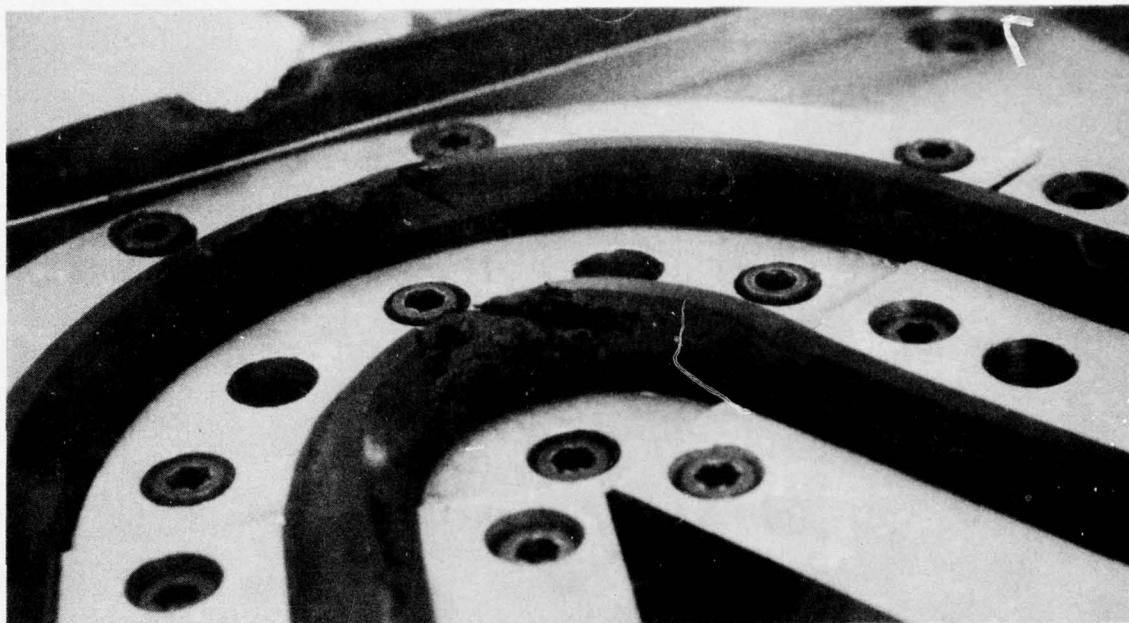

Figure 28 Sliding Seal Set No. 9 - Wear Caused by Long Butt Welding on Titanium Plate

(6) Filler Wire Addition

A thorough investigation of the feasibility of adding a filler wire unit to the SSEB head assembly was made when the head assembly was removed and rotated for the flat plate welding operation. Since the bellows must be located between the sliding seal assembly and upper chamber, it is virtually impossible to introduce a wire feed mechanism or wire feedthrough tube in this area. The small area around the bellows Figures 29 and 30 must remain open so that the flexibility of the weld head is not impaired. Filler wire additions for welding of flat plate and cylinder applications where the sliding seals ride directly on the workpiece are not feasible. Feeding filler wire through the thermocouple port was also investigated. The thermocouple tube would be removed and placed in the boroscope access port. Reworking of the thermocouple tube area to provide the proper bending radius required for filler wire feeding was not possible since it would interfere with the internal vacuum lines for the sliding seals in the head assembly. Guide tubes or nozzles inserted at the end of the thermocouple port would interfere with the EB weld beam. Preplaced filler wire was attempted on the original SSEB welding program and discarded because it interfered with the vacuum sealing of the sliding seals. Preplaced filler wire could be used, however, on the Special-Shapes and Preheat Steel Welding Fixtures. Since the sliding seals moved on the top cover of these fixtures, filler metal could be preplaced on the weld seam. It is possible to add a small mechanized filler wire unit inside the vacuum chamber. For small chambers, such as the Preheat Steel and Special-Shapes Welding Fixtures, the possibility of adding a unit would be very limited, whereas in a large chamber such as the one used for wing beam/slot welding, a filler wire unit could easily be set up. Further investigation of this approach should be carried out and demonstrated, since this idea of slot welding has proven to be a very successful method of SSEB welding and the need for filler wire addition will certainly be required on future hardware.

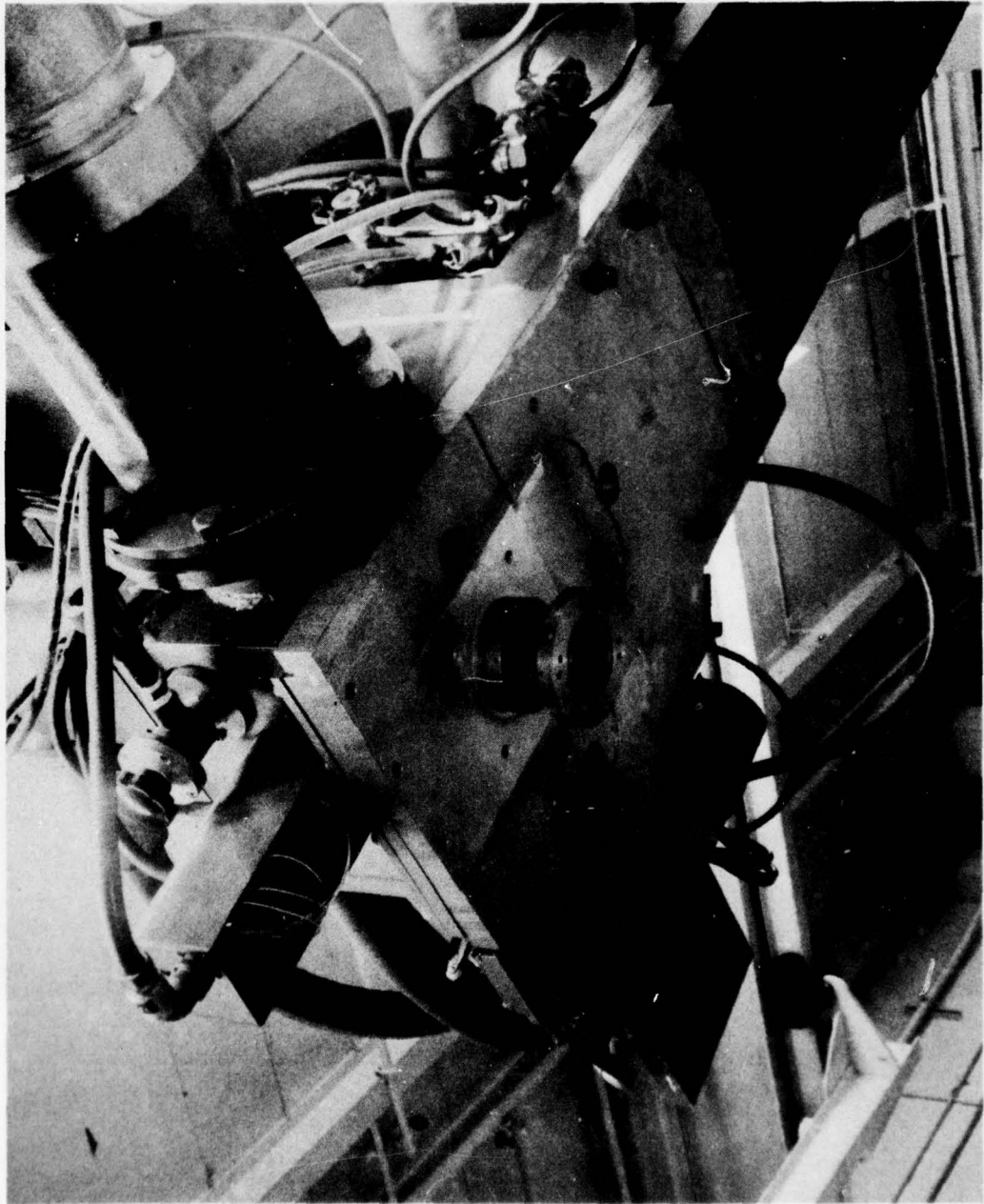

Figure 29 Sliding Seal Head Assembly Removed From Welder

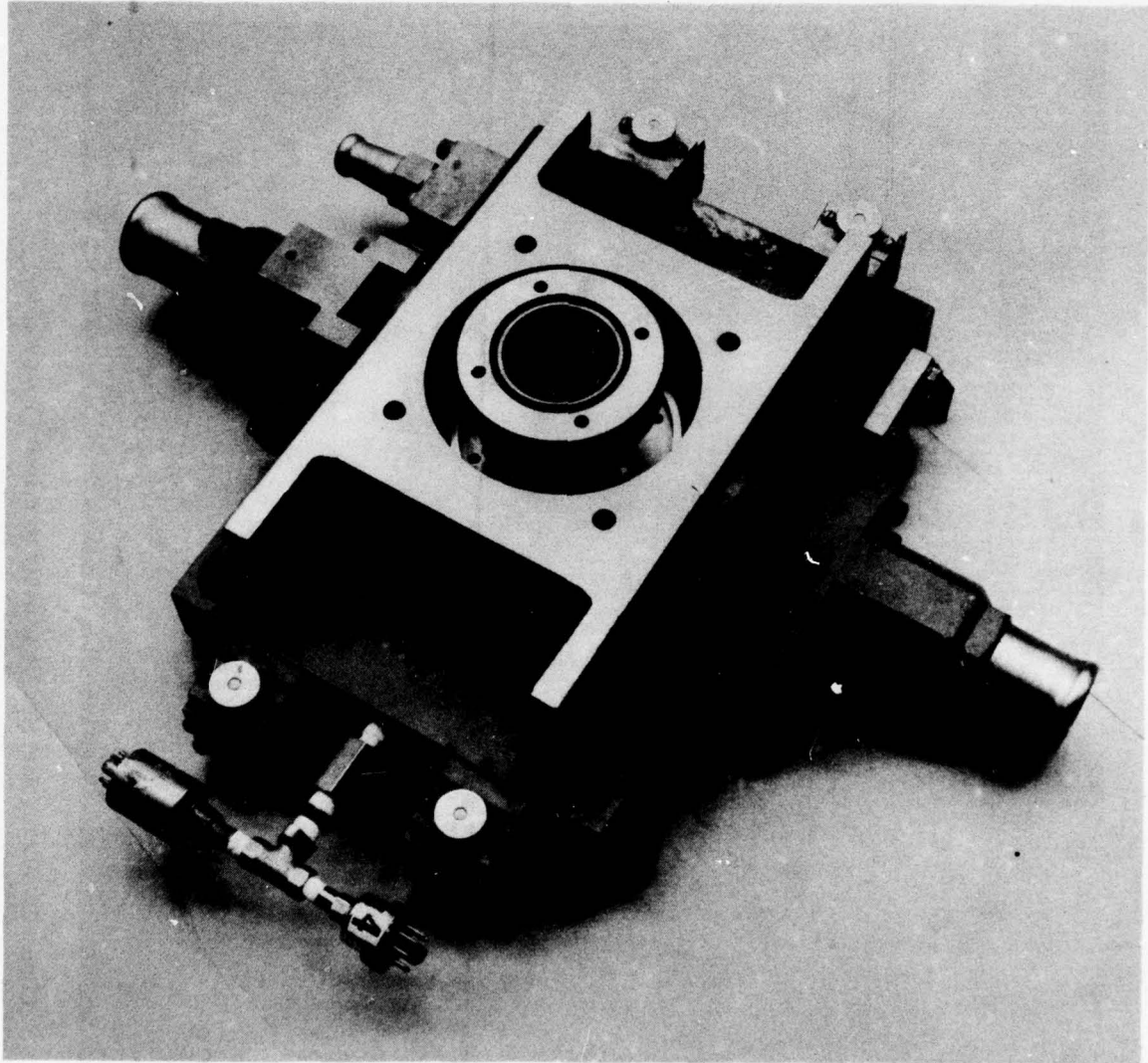

Figure 30 Bellows Remounted Below SSEB Gun Chamber

## 2. Cylindrical Welding Fixture

The SSEB welding of large, cylindrical aerospace structures (e.g., solid- and liquid-propellant booster cases, missile casings and liquid nitrogen tanks) was the original requirement for this process. SSEB welding equipment was designed to make girth welds in 32-foot-diameter right-circular cylinders. Tests have not yet been conducted to determine the degree of head vacuum sealing, turning capability, or the feasibility of using simplified back-up tooling and other vacuum approaches for making such welds on large cylinders.

To demonstrate the capability of the SSEB welder to make circumferential welds, it was necessary to design and fabricate a large-diameter cylinder and support fixture and to develop a method for vacuum sealing the underside of the weld seam.

### a. Material and Hardware Procurement - The following items were purchased:

- Four, 1/2 x 48 x 144-inch 2024-T351 aluminum alloy plate
- Two, 1 x 8 x 240 and two, 2 x 6 x 240-inch hot-rolled steel bars
- Eight, 4-foot long I-beams
- One, 1-inch-thick by 6-foot-diameter hot rolled steel cylinder
- Type D inflatable O-ring seals
- Barco swivel-joint vacuum fitting.
- Swagelock fittings (one-inch pipe thread to one-inch tubing).

Material for the eight support stands and other required hardware items were obtained from company stock.

### b. Fabrication of Fixture - The base support ring (Figure 31) for the cylinder welding operation was fabricated as follows: Two, 1 x 8 x 240-inch, hot-rolled steel bars were rolled to form a 12-foot-diameter ring. Eight, four-foot-long, I-beams were used to join the base support ring to a six-foot-diameter, one-inch-thick plate. This assembly was welded and then machined on a King lathe which can handle parts up to 15 feet in diameter. After machining, eight support stands were mounted on the base support ring to hold the backup vacuum ring in position.

The backup vacuum ring was similarly fabricated by rolling, welding and machining. Two, 2 x 6 x 240-inch, hot-rolled steel bars were rolled and formed to make a 12-foot-diameter ring. The backup bar area and two O-ring grooves were machined in the ring which was then aligned and mounted on the base assembly (Figure 32). The backup vacuum ring was then removed from the base assembly to permit drilling and tapping of 80 standoff bolt holes that centered and supported the aluminum cylinder during welding. The backup vacuum ring was reassembled with the aluminum cylinder in the SSEB welding area.

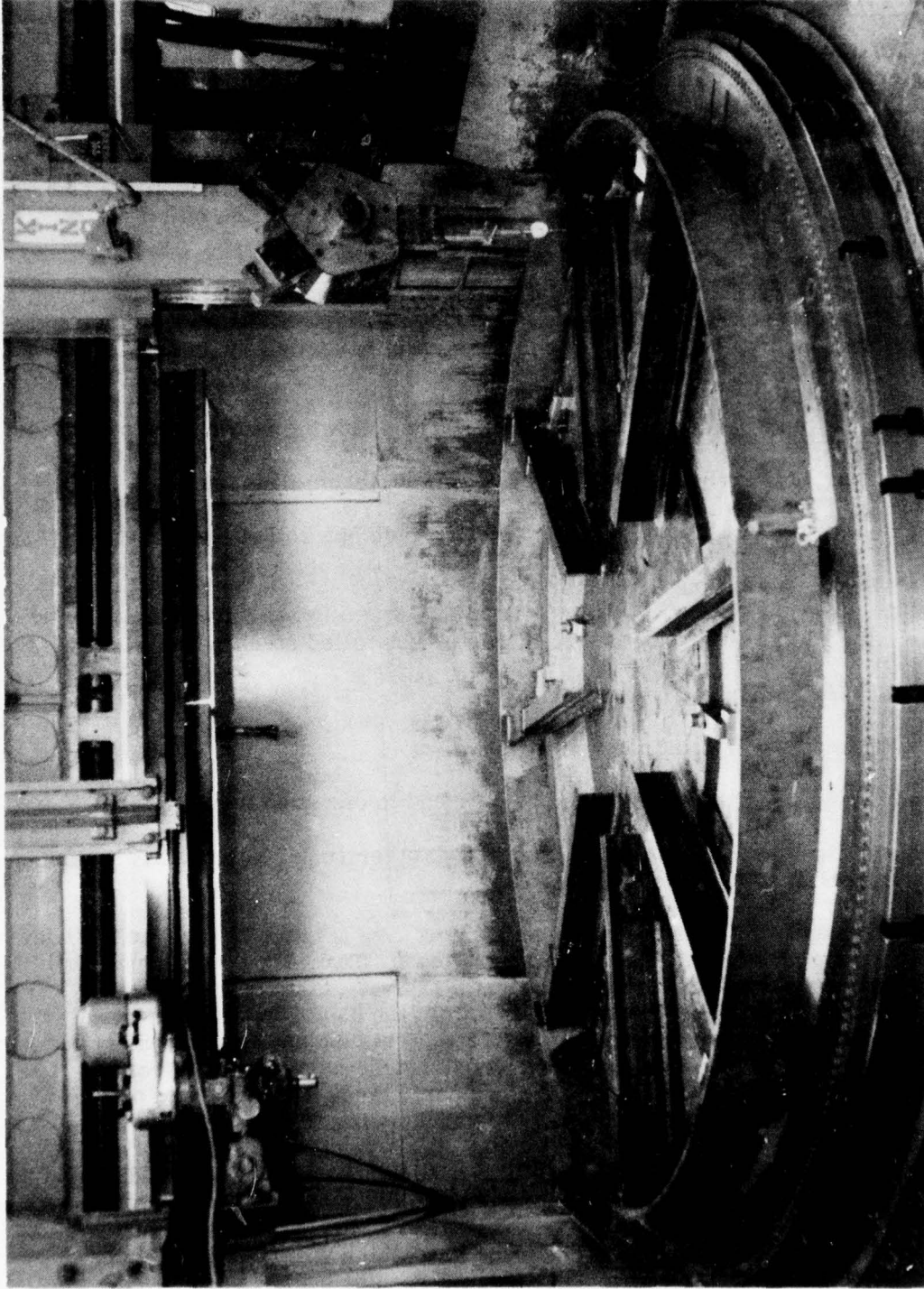

Figure 31 Base Support Ring For Cylinder Welding

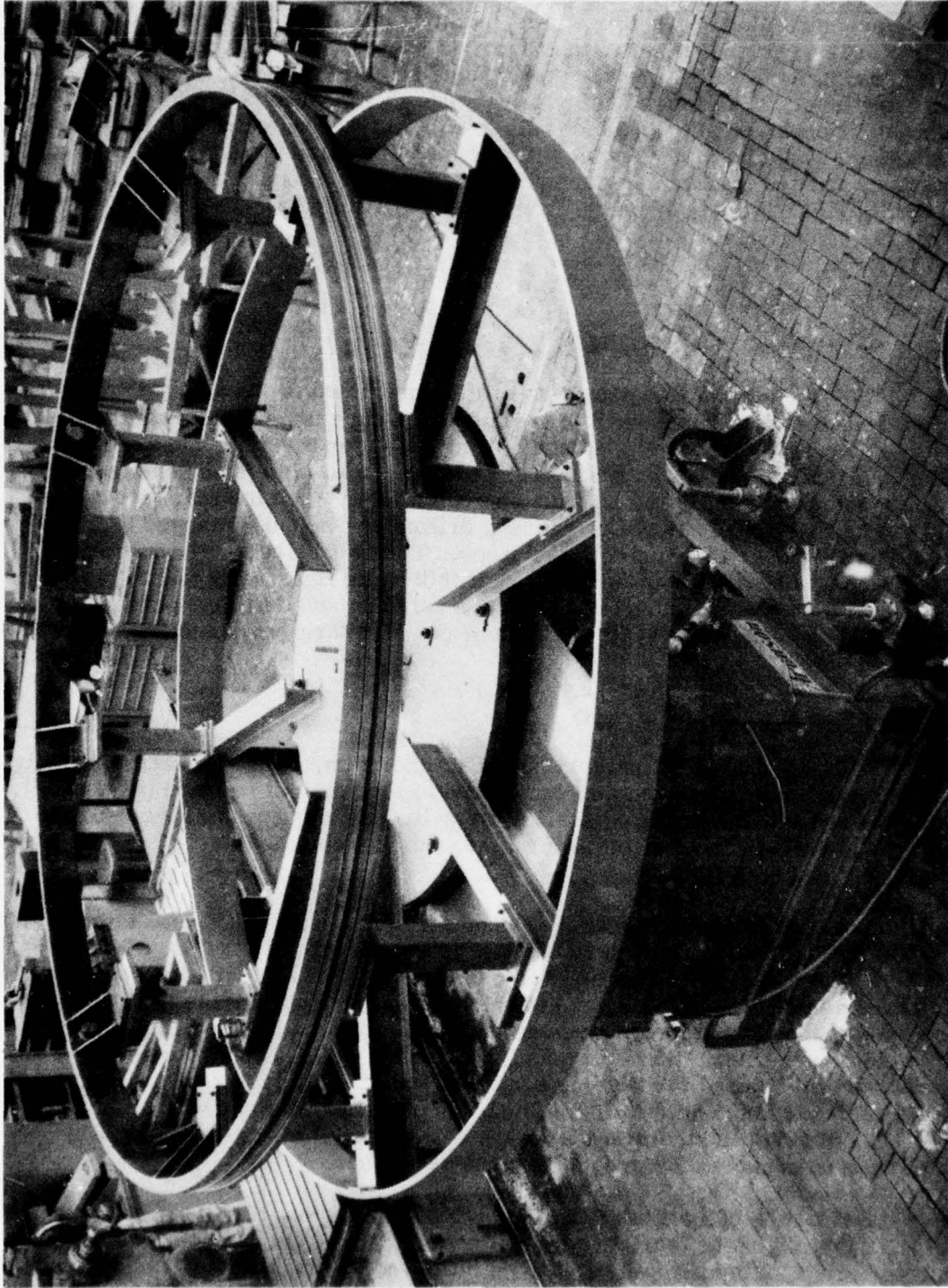

Figure 32 Cylinder Weld Tooling Setup

c. Installation in SSEB Welding Facility - The base support ring and backup vacuum ring were assembled and bolted together. After installation of vacuum lines, the cylinder halves were positioned in the fixture. The cylinder was centered on the vacuum backup ring by adjusting the standoff bolts to size the cylinder to the proper curvature. The fixture and cylinder were then positioned on top of the Aronson Positioner (Figure 33) which was levelled by screw jacks to insure that the weld seam would be in alignment with the electron beam during welding. The cylinder was rotated to check alignment accuracy. The Aronson Positioner was bonded to the floor in four places to give it a permanent base. The final assembly is shown in Figure 34.

d. Equipment Head Modifications

(1) Fabrication Of Curved Head Plate

A 13 x 9 x 1 inch aluminum plate was profile-machined to the desired cylindrical contour and checked for proper curvature against the outside of the cylinder. The vacuum holes and bolting holes for the plate were drilled from the back side of the plate using the existing head plate as a template for spacing and alignment of the holes. The holes for the holding clamps were laid out on the face of the plate, spaced, drilled and manually tapped to facilitate proper installation of the clamps. The bolt holes for the radiation shielding were also laid out and drilled at this time. Figure 35 shows the curved head plate after completion of the machining and drilling operations. Figure 36 shows the head plate with a new set of sliding seals and the installed radiation shield.

(2) Vacuum Sealing on Cylinder

Since the cylinder was welded in a horizontal position, the SSEB head assembly was removed from the boom and remounted in the vertical position (Figure 37). After the boom was positioned against the cylinder, vacuum tests were conducted. A vacuum level of 15 microns was quickly obtained in the head seal area.

Some operating difficulties occurred when an attempt was made to rotate the cylinder. The Z-axis limit switch immediately reverted to the Sequence Stop position, thereby controlling the head pressure against the cylinder surface. Compression of the sliding seals and the bellows assembly in the head had to be adjusted to allow ample movement so that the limit switch would not stop the welding sequence. Secondly, flat spots on the cylinder wall caused loss of vacuum which stopped the welding sequence and activated the Z-axis limit switch. Because the outside diameter of the cylinder was machined to a tolerance of  $\pm 1/8$  inch, flat spots on the cylinder wall necessitate use of a floating head capable of overcoming these deviations.

After rotating the cylinder 360 degrees, it was found that the flat spots occurred only in the area of the four MIG-welded seams. The cylinder could be moved only several feet before loss of vacuum occurred, or sequencing was stopped by the limit switch. The other areas of the cylinder were perfectly formed,

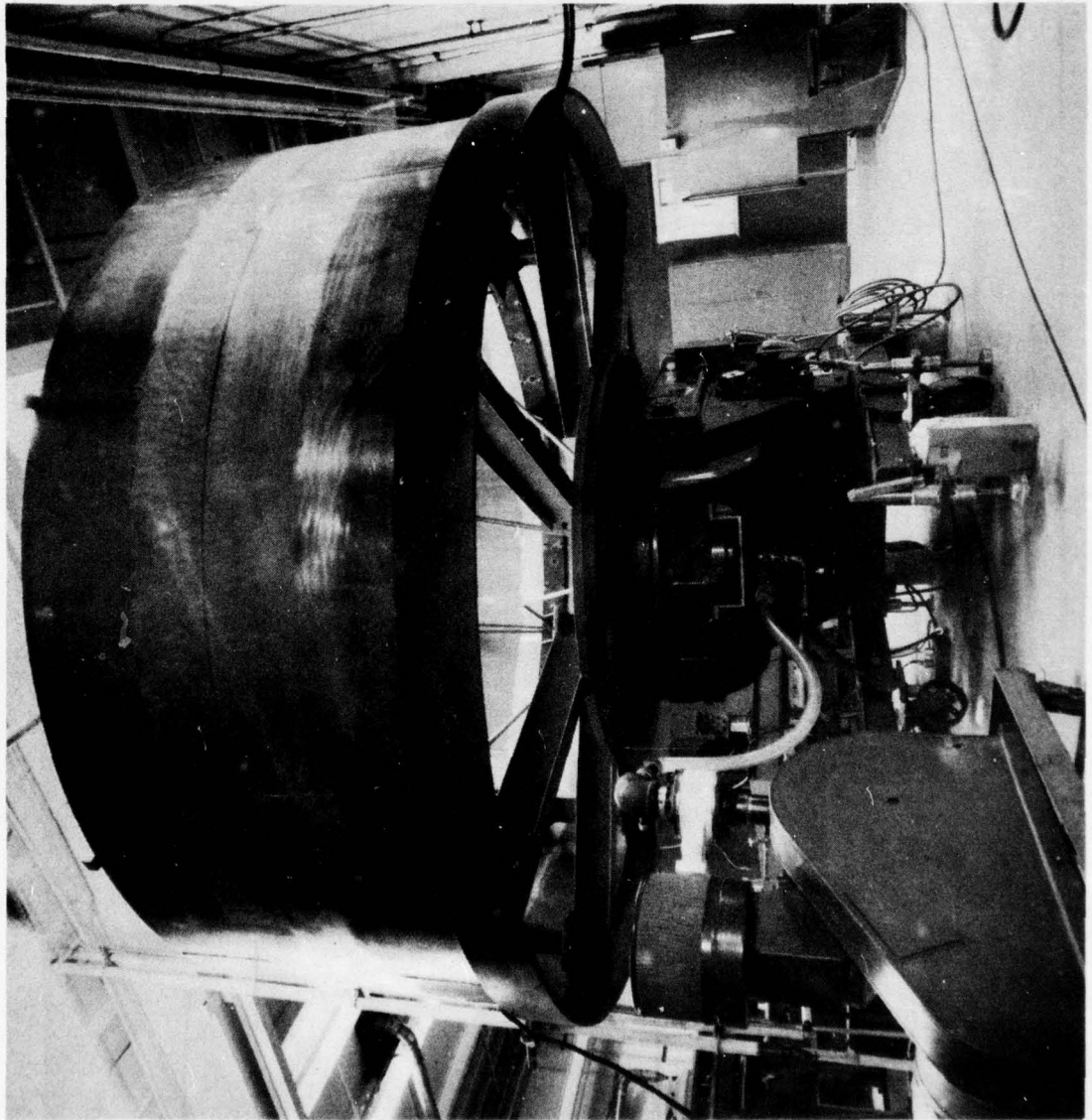

Figure 33 Cylinder on Aronson Positioner

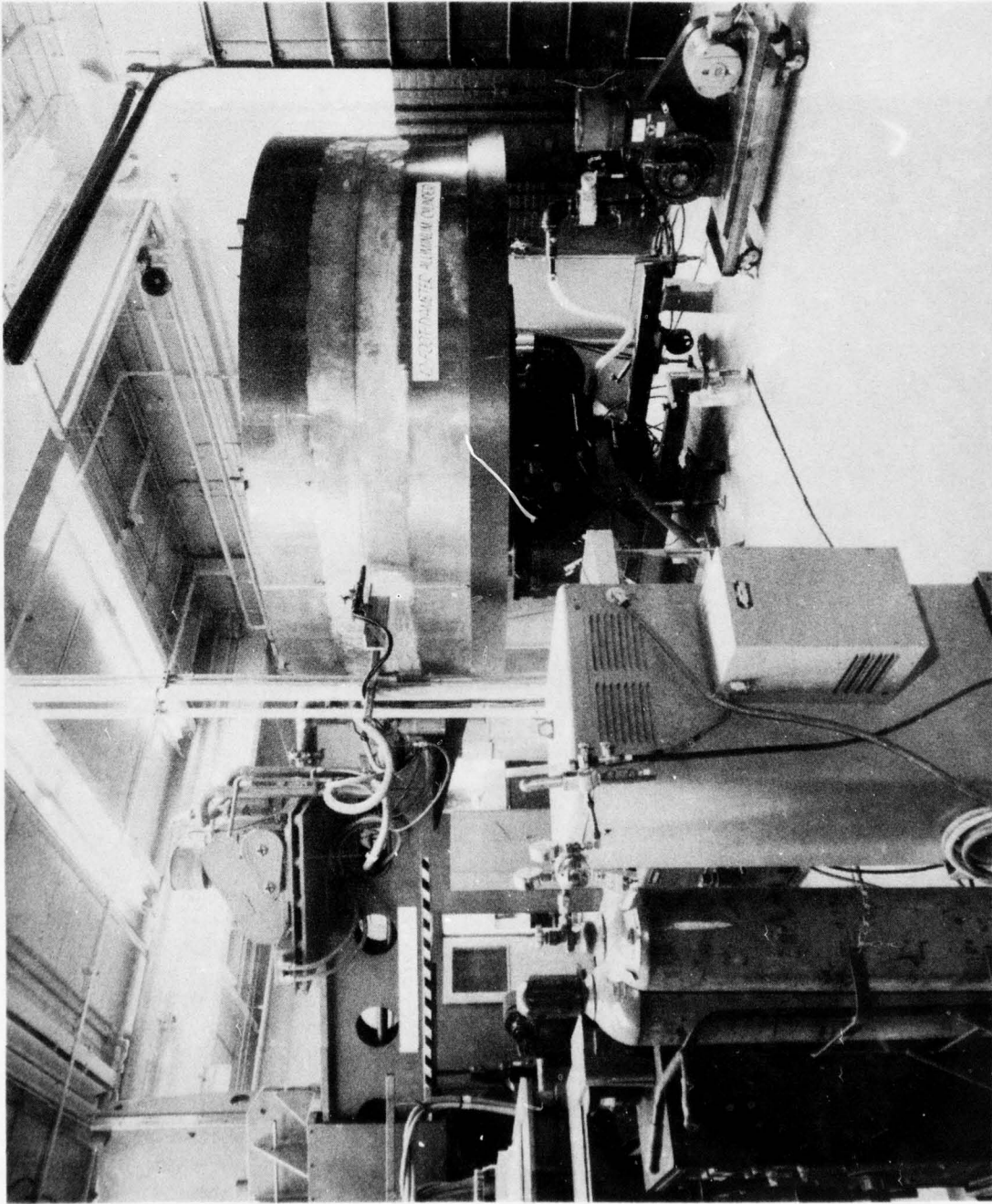

Figure 34 Cylinder in Position For GTA and SSEB Welding

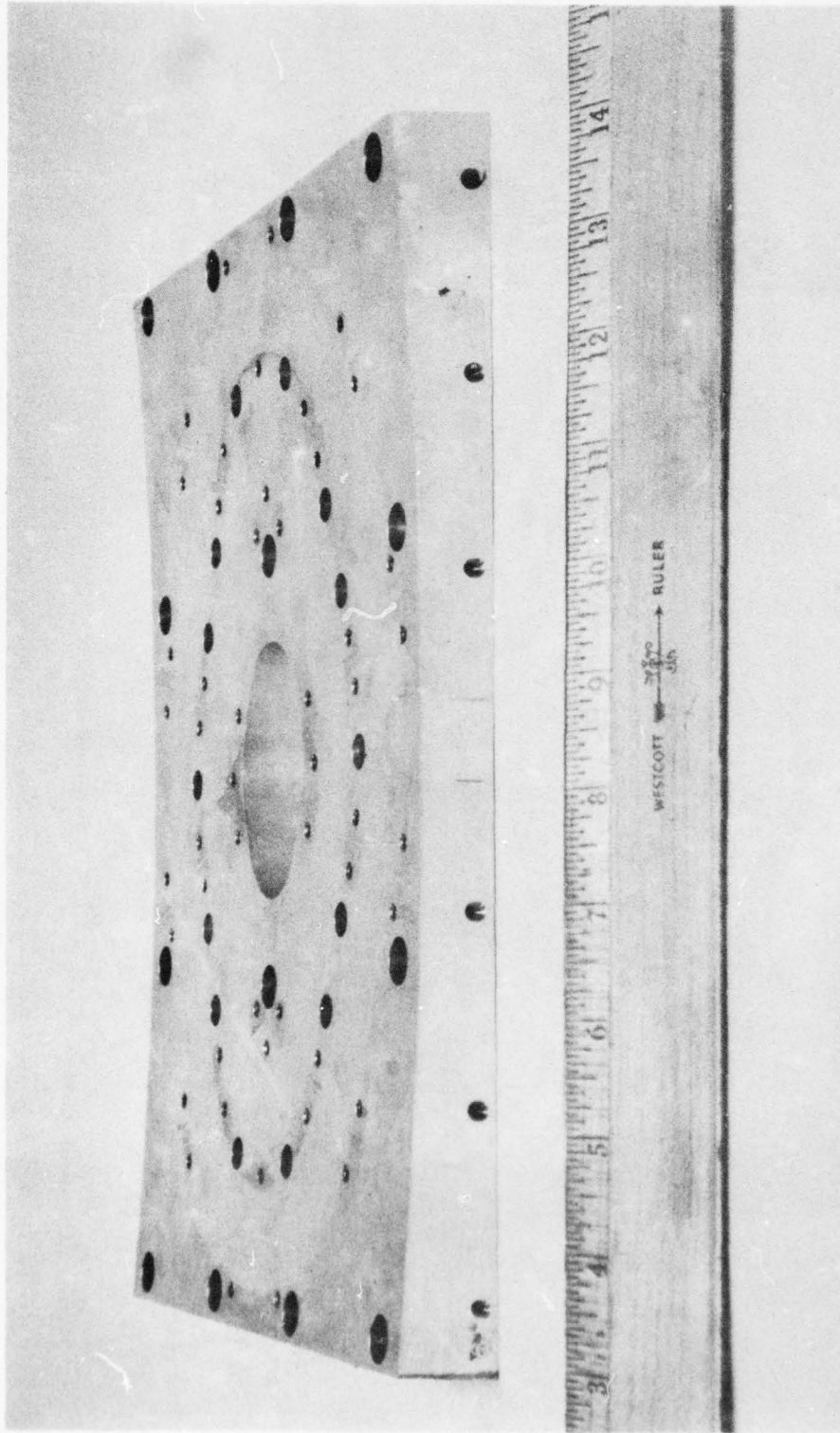

Figure 35 Curved Head Plate for SSEB Welder

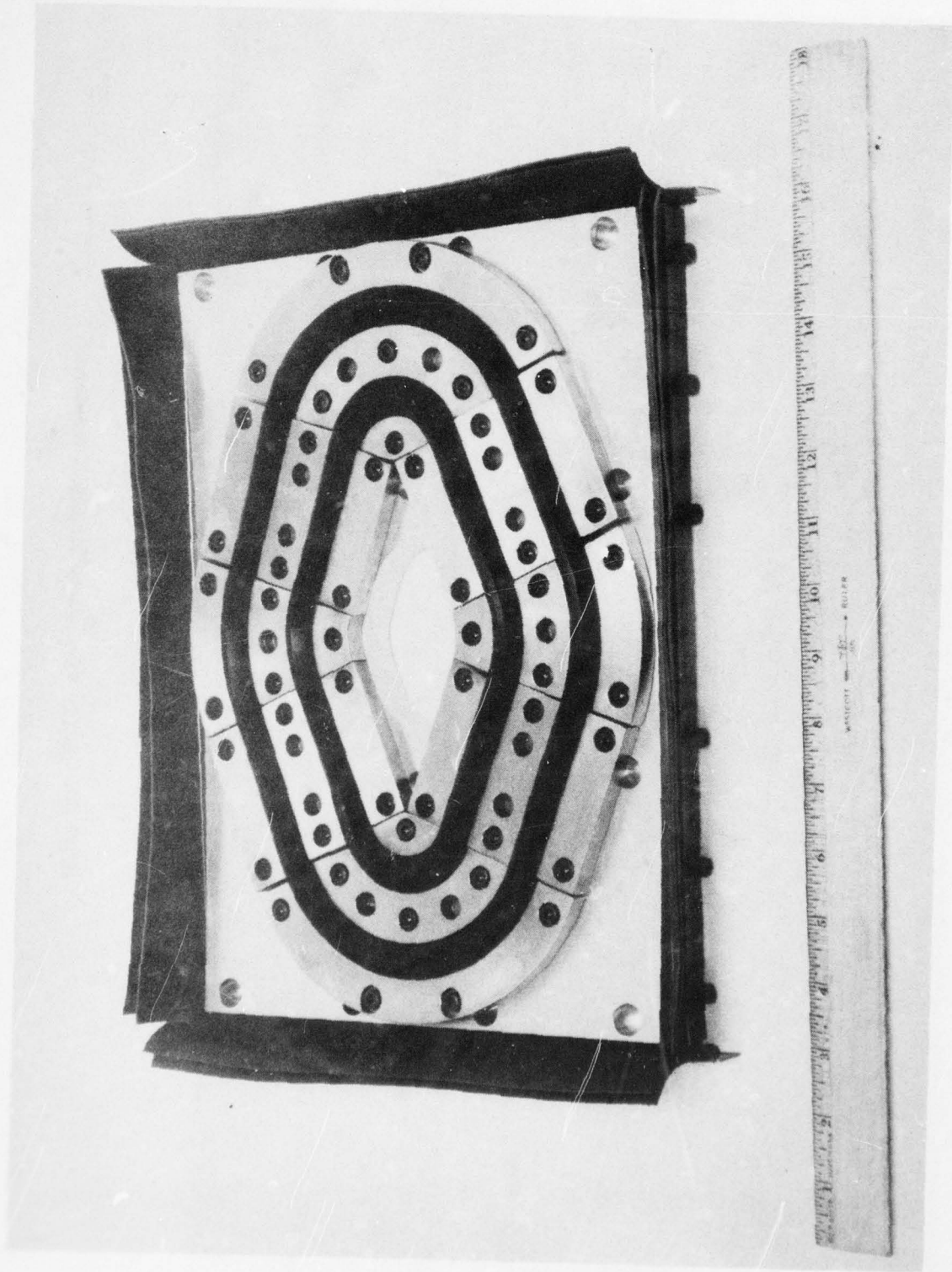

Figure 36 Sliding Seals and Radiation Shielding on Curved Head Plate

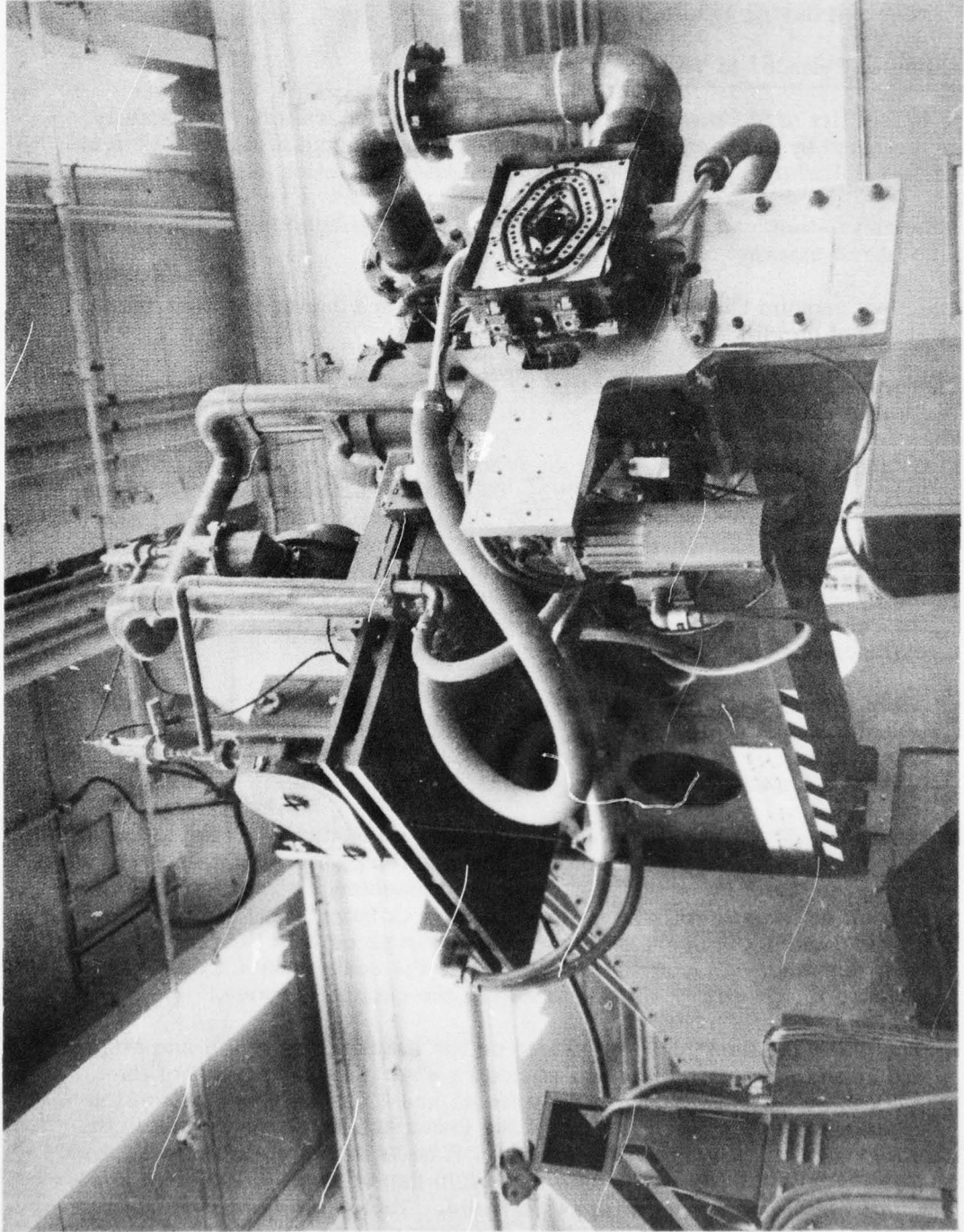

Figure 37 SSEB Head Assembly With Curved Head Plate Mounted in Vertical Position

making it possible to maintain vacuum and rotate the cylinder for six to eight feet without difficulty. After the desired vacuum level was reached, the boom and cylinder were aligned, and the limit switch was adjusted. It was now possible to maintain the vacuum level and rotate the cylinder without sequence stopping. Since head movement could be controlled in this manner, it was decided that use of the proximity control would not be required during welding.

e. Welding of Cylinder to Verify Tooling Concept

The feasibility of SSEB welding large-diameter cylinders was successfully demonstrated by completion of a 166-inch-long continuous weld on a 12-foot-diameter cylinder. This weldment demonstrated the following:

- Internal tooling can rigidly support and align a cylinder for welding without the use of external clamping
- Internal vacuum back-up levels can be maintained during rotation and welding of a cylinder
- A curved head plate can be sealed by sliding seals against the outside surface of a rotating cylinder.

- (1) Cylinder Fabrication - A 12-foot-diameter cylinder was fabricated from four, 1/2 by 48 by 144-inch, 2024-T351 aluminum alloy plates. These plates were rolled, sawed and edge-machined for butt welding. Two V-joints were machined on the edges so that two metal-inert-gas (MIG) welds could be made simultaneously on the cylinder. Figure 38 shows the cylinder set up for MIG welding. Figure 39 shows the cylinder after the first weld was made, and the base support ring that supported the cylinder during welding.

After welding, the cylinder was machined on a King lathe around its circumference to provide two, 2-foot-wide cylinders. These sections were edge-milled to give flat and parallel edges, and to insure a square-butt fitup for SSEB welding operations.

- (2) Installation of Inflatable Seals and Cylinder on Fixture - Prior to installation of the cylinder halves on the support fixture, the inflatable seals were bonded to the back-up vacuum ring. The machined retainer grooves were solvent degreased and pretreated with Dow Corning's 200 metal primer. The two inflatable seals were then bonded in place with Dow Corning 731 RTV cement. After curing for 24 hours, the seals were inflated and checked for proper fit and expansion in the retainer groove.

The lower cylinder half was placed on the fixture (Figure 40) and aligned and centered using the special standoff bolts. Close-up views of the inflatable seals are shown in Figures 41 and 42. The upper half of the cylinder was then placed on top of the lower half and sized to match the lower section. By adjusting the standoff bolts it was possible to eliminate any mismatch in the weld seam. A slight gap of about 0.100 inch; however, existed along eight feet of the weld seam. This gap was attributed to the lathe machining operations, since clamping was not used to hold the cylinder flat during machining. The several clamping arrangements that were tried to eliminate the gap were not successful.

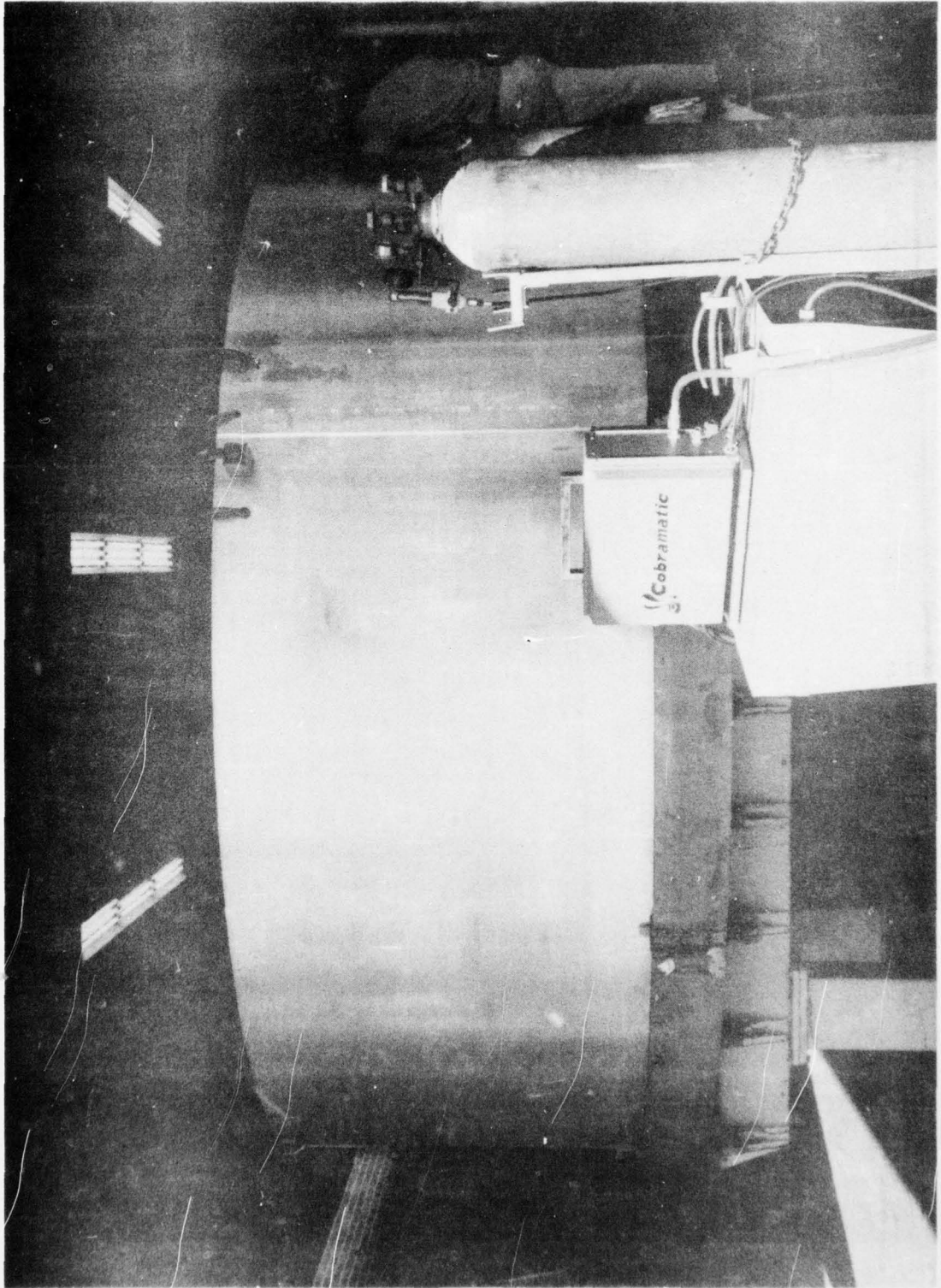

Figure 38 MIG Welding Setup For Cylinder

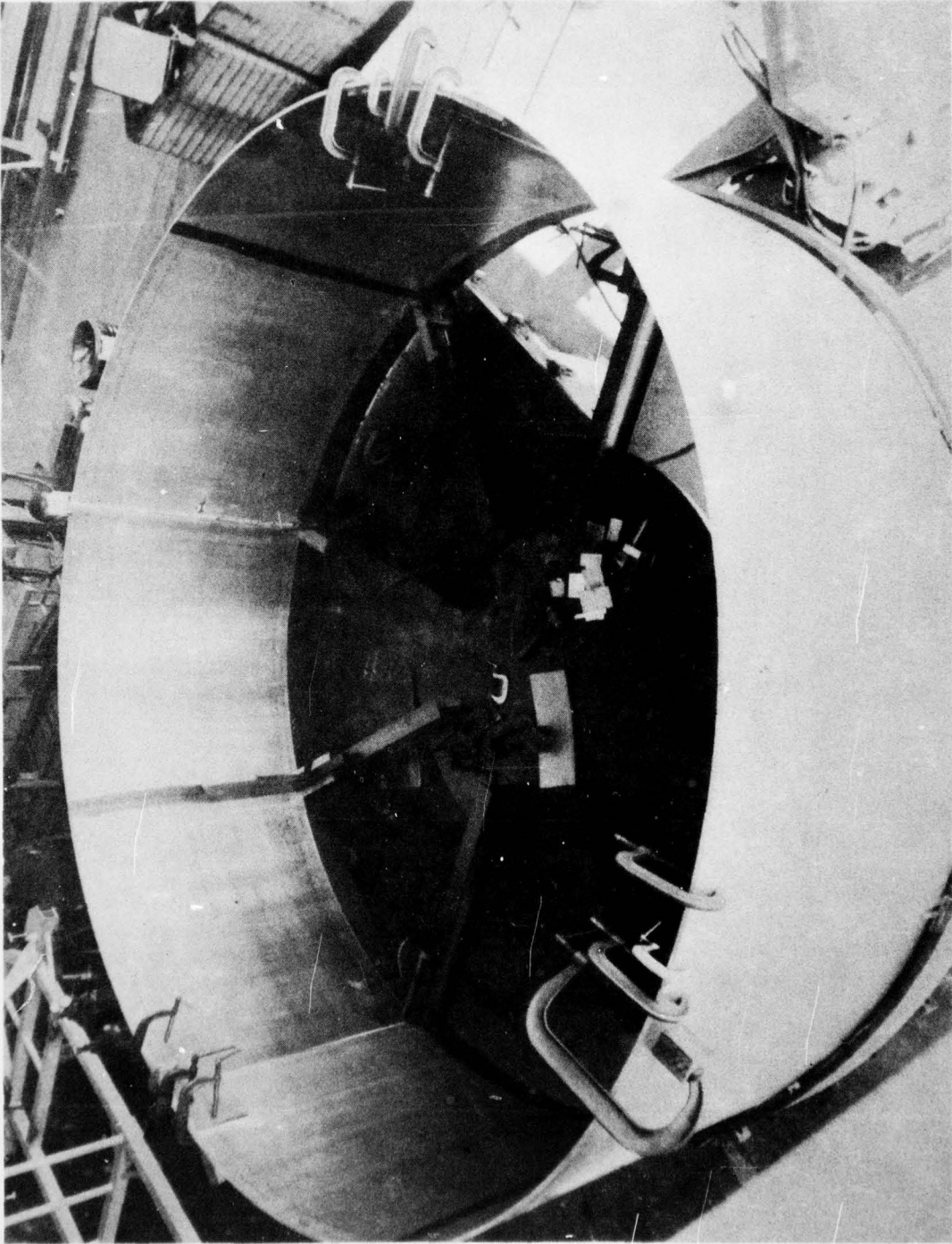

Figure 39 Partially Welded Cylinder

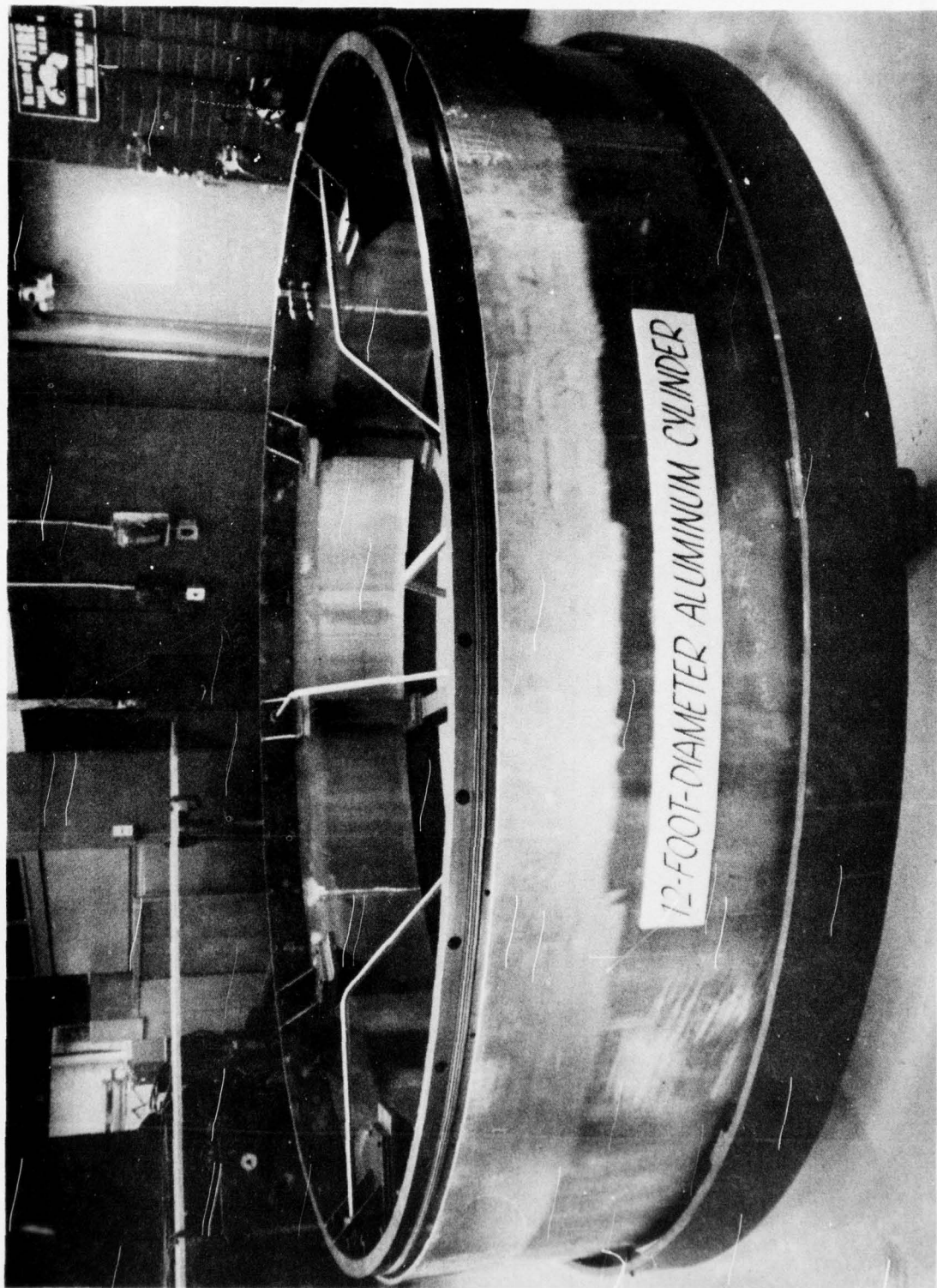

Figure 40 Lower Half of Cylinder on Fixture

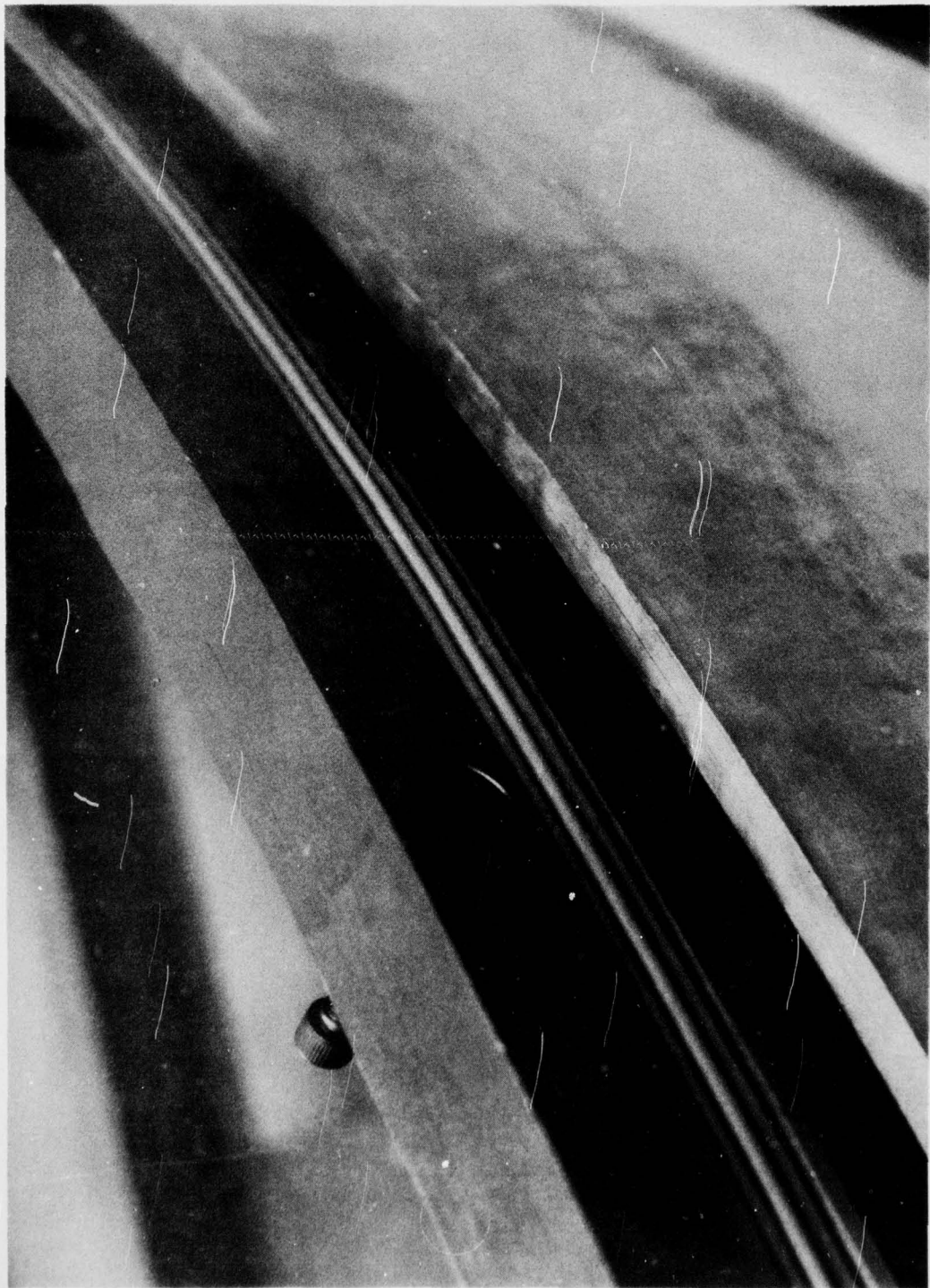

Figure 41 Inflatable Seal in Released Position

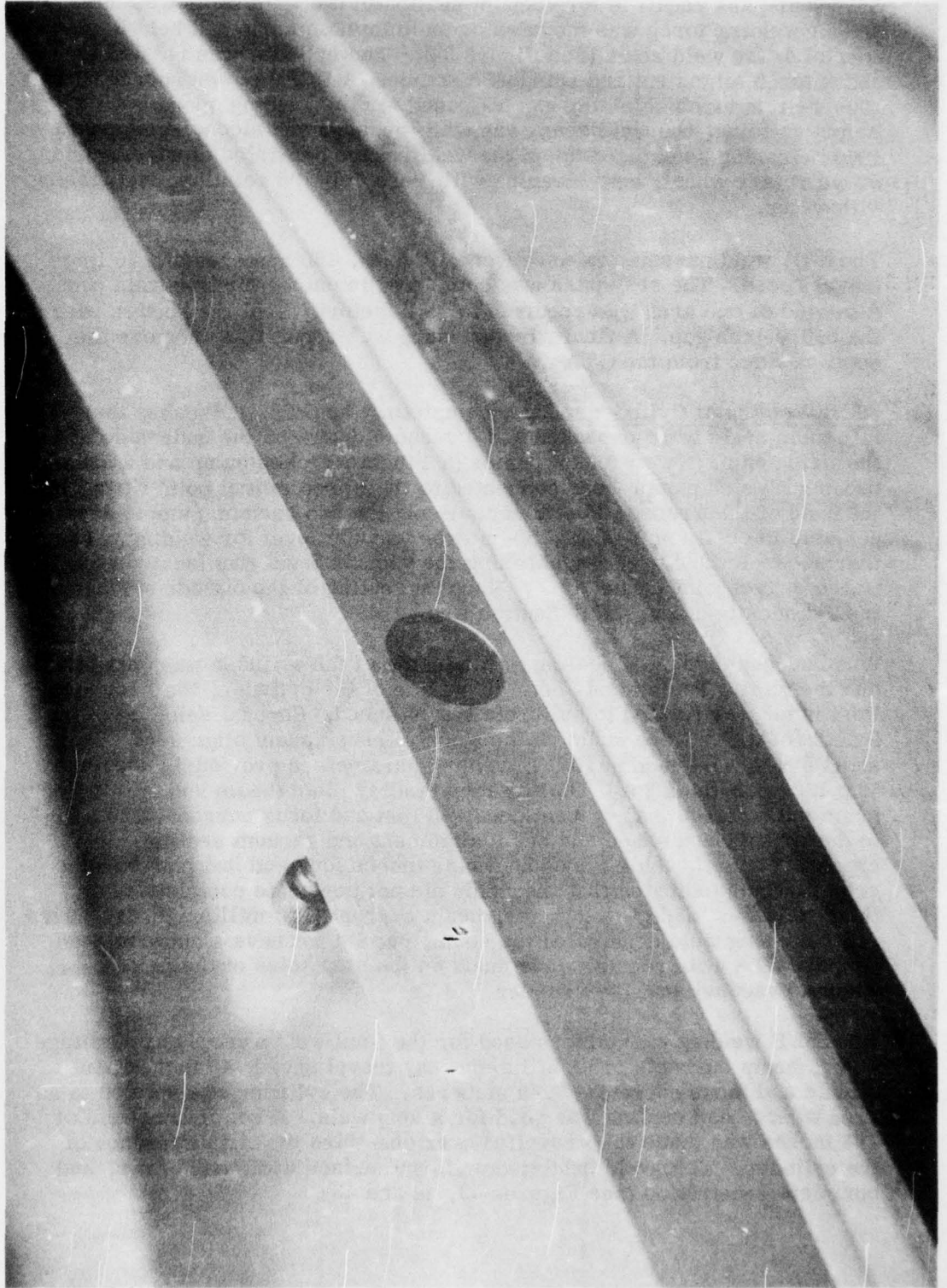

Figure 42 Inflatable Seal in Expanded Position

- (3) GTA Seal-Pass Welding - Following placement of the cylinder on the support fixture and location of the fixture on the Aronson Positioner, the GTA seal-pass required for vacuum sealing of the weld seam was made. A GTA welding torch was mounted on an aluminum angle and held in place normal to the weld seam (See Figure 34). The cylinder was rotated to check torch alignment and standoff distance. A DCSP power source with 100% helium torch shielding gas was used for the welding operation. Before welding, the weld seam was wire-brushed and alcohol-cleaned. Prior cleaning before set-up on the weld fixture consisted of wire brushing with a rotary wheel, acid cleaning with Pasa Jell 105 solution, and rinsing with water.

The GTA weld parameters used were 18 volts, 150 amperes and 20 ipm travel speed. The seal-pass was completed in one continuous weld pass. A reweld of one area was required to satisfactorily seal the section with the 0.060-inch gap. A final wire brushing was required to remove the sooty residue from the GTA weld.

- (4) SSEB Welding of Cylinder - After completing the GTA seal-pass, the inflatable seals were expanded and a vacuum drawn on the underside of the weld seam. Two vacuum pumps (a 140-cfm Stokes pump and a 53-cfm duo-seal Welch pump) were connected to the Barco swivel point fitting at the base of the Aronson Positioner. Using the two vacuum pumps, it was possible to obtain and hold a 150-micron vacuum level for welding. The thermocouple tube used for checking the vacuum level was located near the Barco swivel joint connections. Vacuum sealing of the outside surface of the cylinder is discussed in Section III B.2.d.

When adequate vacuum sealing of the inside of the cylinder was obtained and the sliding seals located on the outside of the cylinder, the Aronson Positioner was rotated to calibrate travel speed. Several selected short lengths of welds were made on the seam to check seam alignment. Two short welds were made with EB welding parameters previously used to join 1/2-inch-thick 2024-T651 aluminum alloy plate (beam voltage-40 kv, beam current-100 ma, travel speed -40 ipm and focus current-6.40 amps) to determine bead shape and seam alignment and vacuum sealing capability. Both welds were about nine inches long and had high surface crowns which indicated that the welds did not penetrate completely. A third weld was made with a higher beam current (120 milliamperes). This six-inch-long weld penetrated the seam, but did not have a uniform bead shape. GTA weld repairs were made on the stop holes of the three short welds to vacuum seal the cylinder.

The SSEB welding parameters used for the final weld were: beam voltage-40 kv, beam current-, 150 milliamperes, travel speed -40 inches per minute and focus current - 6.40 amperes. The cylinder was rotated to an area where head sealing was good for a long weld. A continuous weld of 166 inches was made that travelled over one-third the circumference of the cylinder. This weld exhibited uniform surface width and crown, and complete penetration (see Figures 43, 44 and 45).

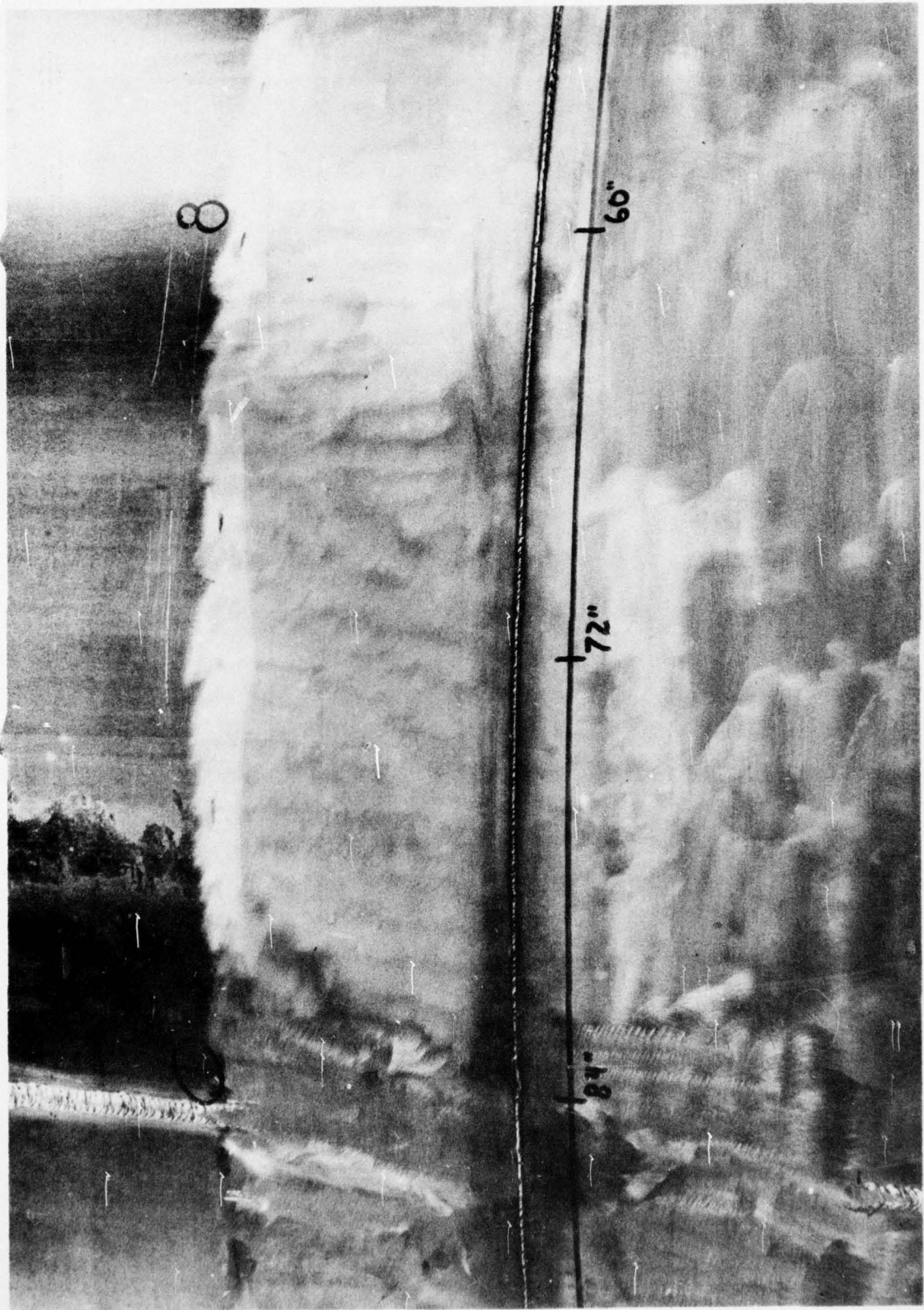

Figure 43 Five to Seven-Foot-Long Section of SSEB Cylinder Weld

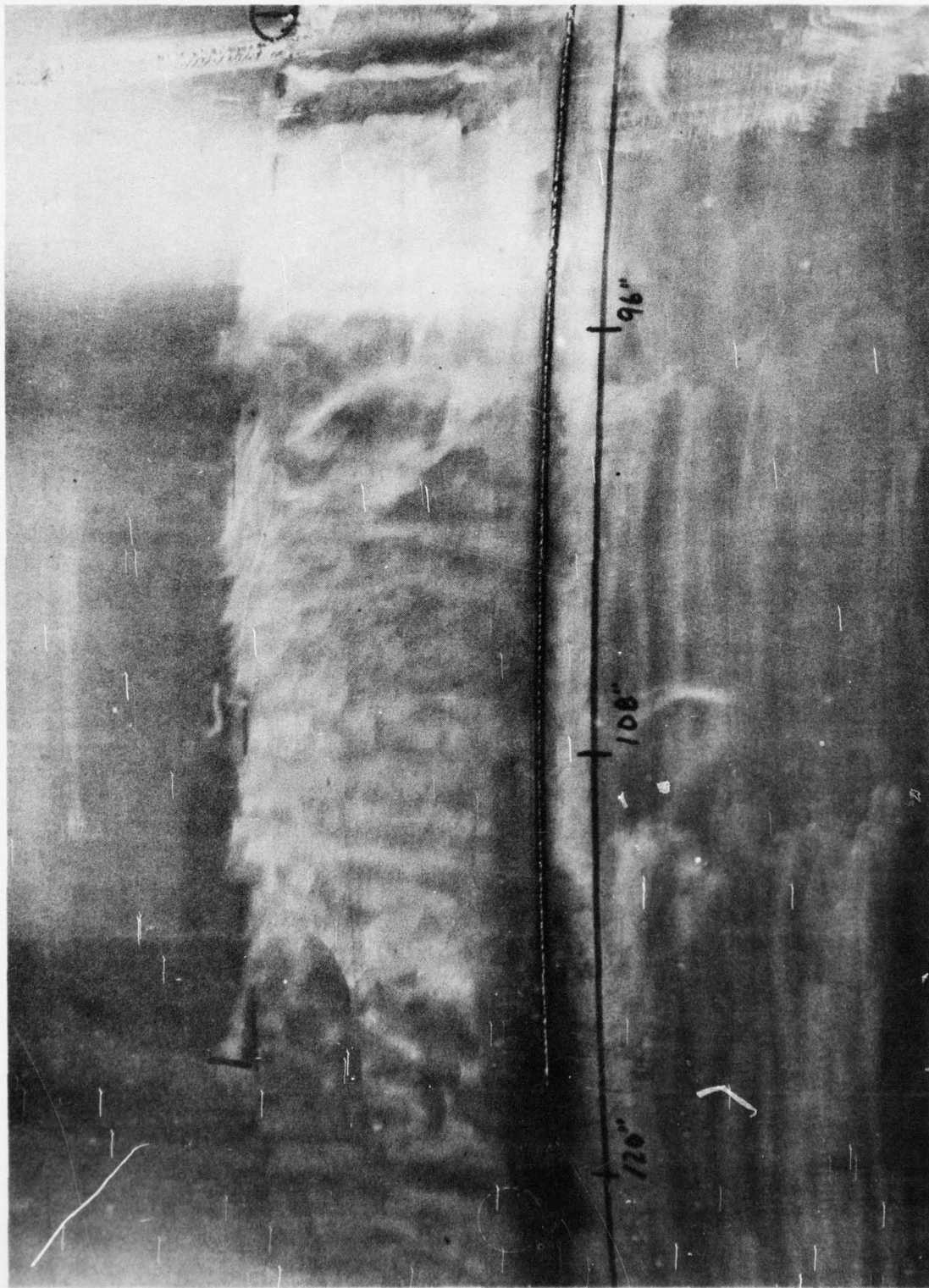
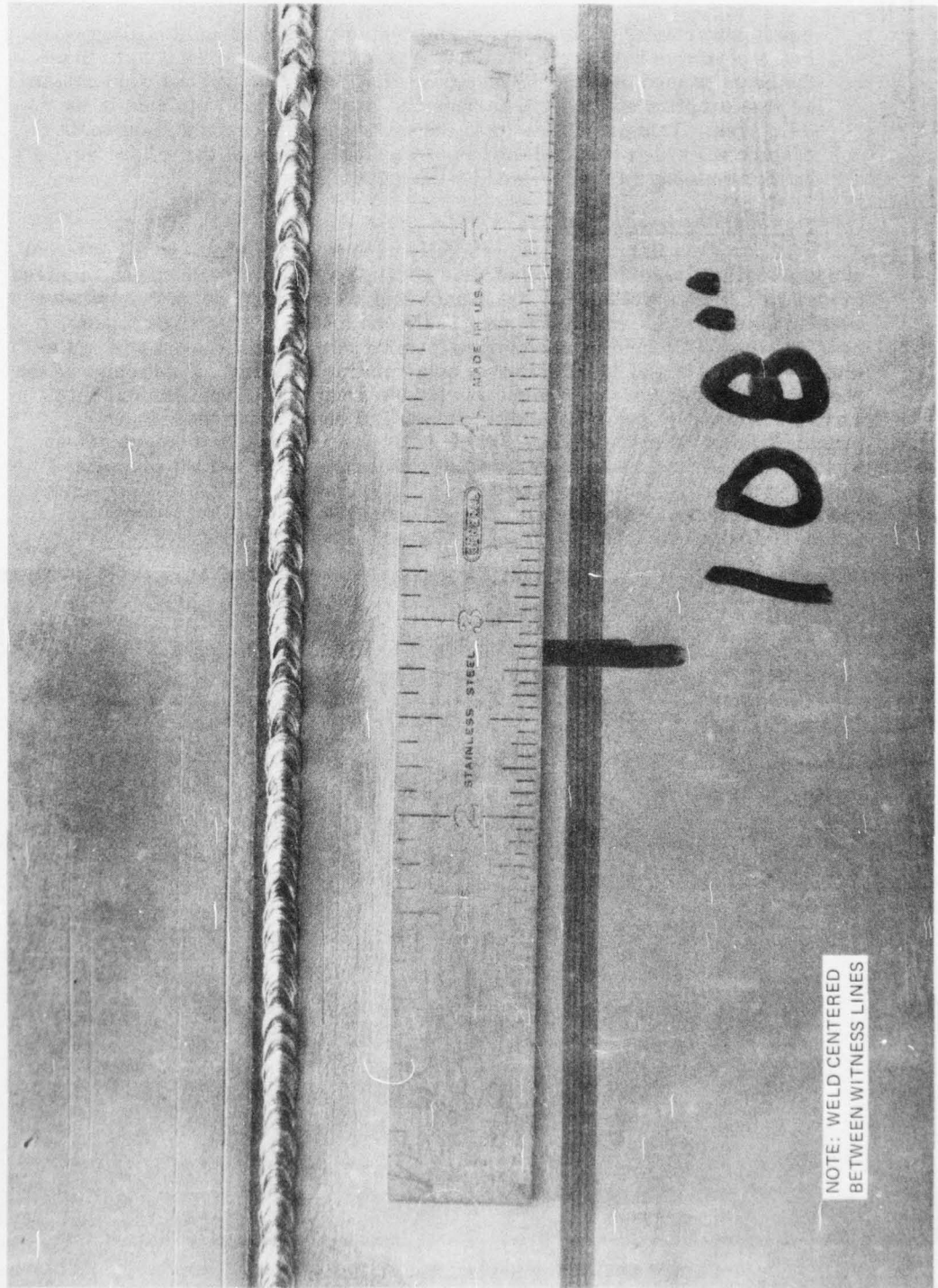

Figure 44. Eight to Ten-Foot Long Section of SSEB Cylinder Weld



NOTE: WELD CENTERED  
BETWEEN WITNESS LINES

Figure 45 Close-Up View of SSEB Cylinder Weld

Beam power was held constant during welding. The vacuum sealing level in the head was held at 25 microns. After 130 inches of weld were made the beam passed over the GTA-repair stop hole of the second weld causing a large eruption on the weld surface and leaving a small pin hole in the weld area. This projection from the weld surface cut the sliding seals (Figure 46) which resulted in loss of vacuum and end of the weld. No further welding was performed on the cylinder.

f. Cylinder Welding Evaluation

The cylinder weld fixture was successfully used to demonstrate local, internal support tooling, vacuum sealing of weld backup and head modifications required to make a cylinder weldment. A 166 inch long weld was made on the cylinder which showed that inflatable "O" ring seals can maintain adequate vacuum pressure for SSEB welding and proper forming of the sliding seals will maintain a vacuum level of 15-25 microns on a rotating cylinder. Positioning of the head assembly against the cylinder surface was capable of vacuum sealing a 12 foot diameter cylinder formed to within  $\pm 1/8$  inch tolerances. Radiographic inspection of the cylinder (EBF #316) weld showed that the weldment was centered on the weld seam. Porosity detected in the welded seam was caused by the extended time periods from clean, setup, GTA seal pass weld and SSEB welding. Furthermore, the required use of 2024-T351 aluminum for the cylinder weldment was a cause for porosity in the weld.

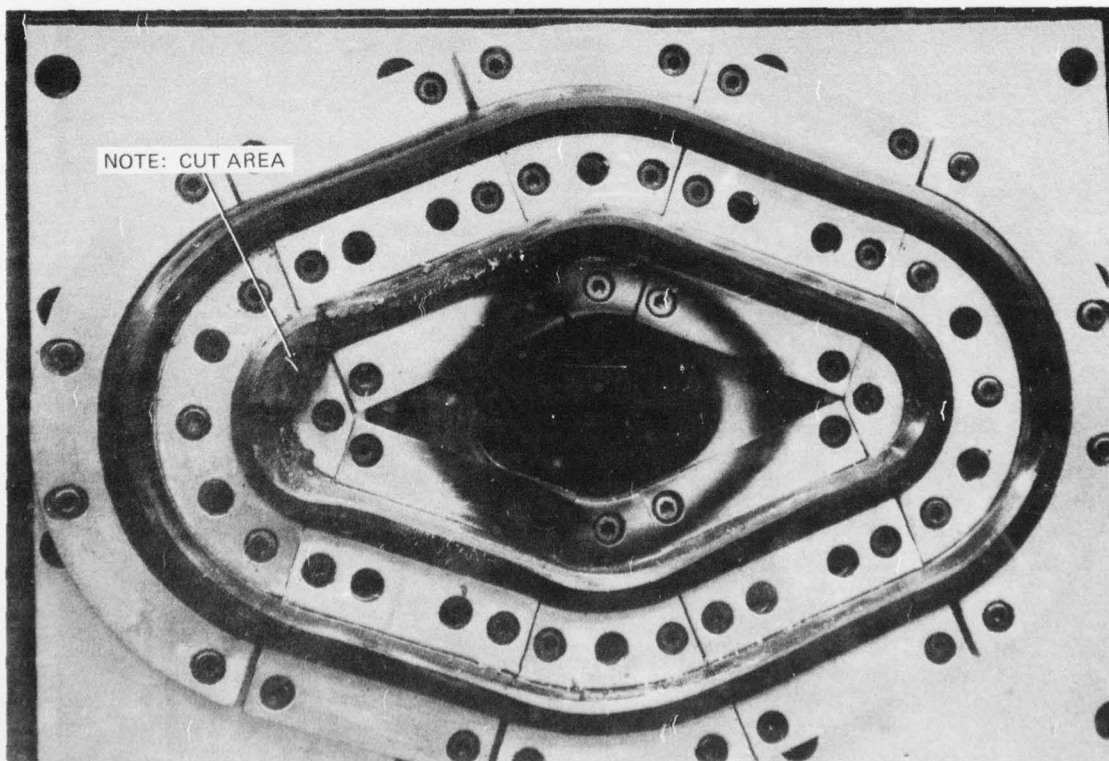

Figure 46 Sliding Seals After Cylinder Weld

### 3. Special Shapes Welding Fixture

This fixture is a 12x12x10-inch box with two 6-inch-diameter holes on opposite sides (Figure 47). Round inserts are used for the workpiece tooling (clamping and aligning), which will accommodate the special vacuum seals and O-ring seals for the fixture. A glass viewing port was installed on one side of the box to permit viewing of the welding operation.

- a. Material and Hardware Procurement - The box side plates, top cover and roller guides were cut from one-inch thick hot-rolled steel plate. The round insert blocks were machined from 1 1/2-inch thick aluminum plate. Purchase requisitions were issued for O-ring cord stock, two pieces of 1/4-inch thick leaded glass, special screw clamps, and angle clips were secured. Silicone rubber and all hardware items (bolts, nuts and washers), were obtained from Company stock.
- b. Welding and Machining of Fixture - Hot-rolled steel plates for the box structure and cover were saw cut and Blanchard ground. This operation insured smooth surfaces on the inside of the vacuum box. The box assembly (Part No. RDM-447-369) was welded and vibratorily stress relieved. The end holes for the insert blocks and viewing port were drilled. The roller guides (Figure 48) inside the box were machined. The round inserts (Figure 49) for workpiece tooling (clamping and aligning) and for accommodating the special vacuum seals were fabricated. Special screw clamps and angle clips were inserted in the roller guides inside the box. The top and bottom surfaces were then machined flat and parallel. The O-ring groove for the cover plate sealing was cut into the top flange. The final operation involved the machining of a 3-1/2-inch long slot in the cover plate, and, drilling of view port hole. An O-ring for the cover seal was then fabricated.
- c. Setup on Weld Table in SSEB Welding Room - Upon completion of the welding and machining operations, the Special-Shapes Welding Fixture was set up on the welding table adjacent to the SSEB welder. The fixture was aligned to the X-axis (boom travel direction) and bolted to the table. Tee angles were inserted inside the fixture and used to check weld seam alignment and gun-to-work distances. Travel limit switches were set on the boom travel to limit the forward travel of the boom to the end of the slot on the cover plate. A plexiglass shield was cut for use as a vapor shield for the inside of the leaded glass port. Eight-inch diameter plates were bolted to the insert block and vacuum sealed with O-rings. The slot on the cover plate was sealed for a leak check of the fixture.

Helium leak checks of this fixture revealed vacuum leaks in the welds of the box structure and the threaded vacuum fitting. Weldments in the leak area were ground flush and repaired by GTA welding. The vacuum fitting was removed and replaced by a steel tube which was welded to the fixture. A thermocouple tube was also added to the new vacuum port to obtain more accurate checks of the vacuum level within the fixture. A subsequent helium leak check of the fixture showed a vacuum level of 20 microns which is the level required for the welding effort.

AD-A031 901

GRUMMAN AEROSPACE CORP BETHPAGE N Y  
SLIDING-SEAL ELECTRON-BEAM WELDING.(U)  
JAN 76 H P ELLISON, R H WITT

F/G 13/8

F33615-73-C-5030

UNCLASSIFIED

AFML-TR-76-3

NL

2 OF 3  
AD A031901

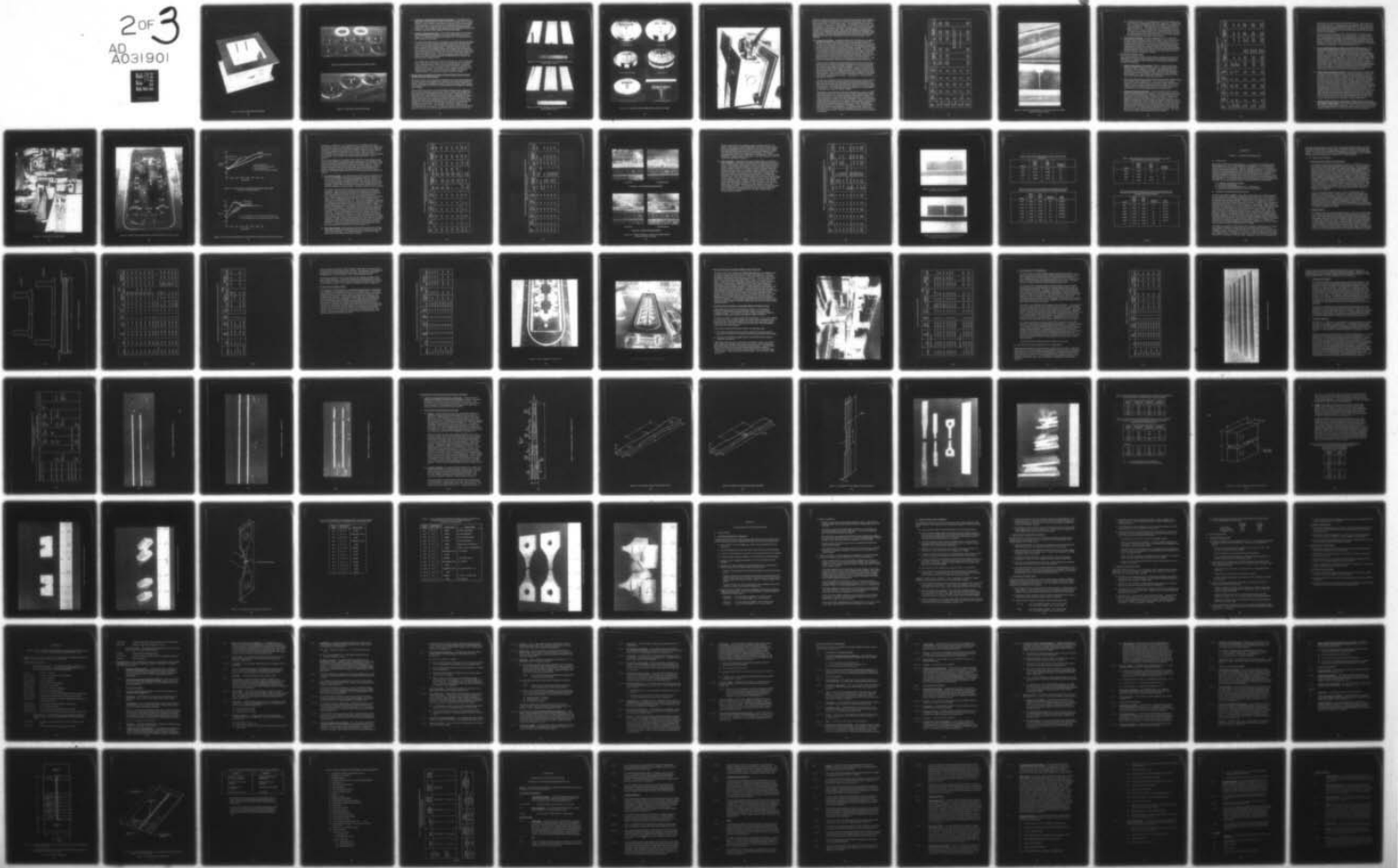

106  
F  
3

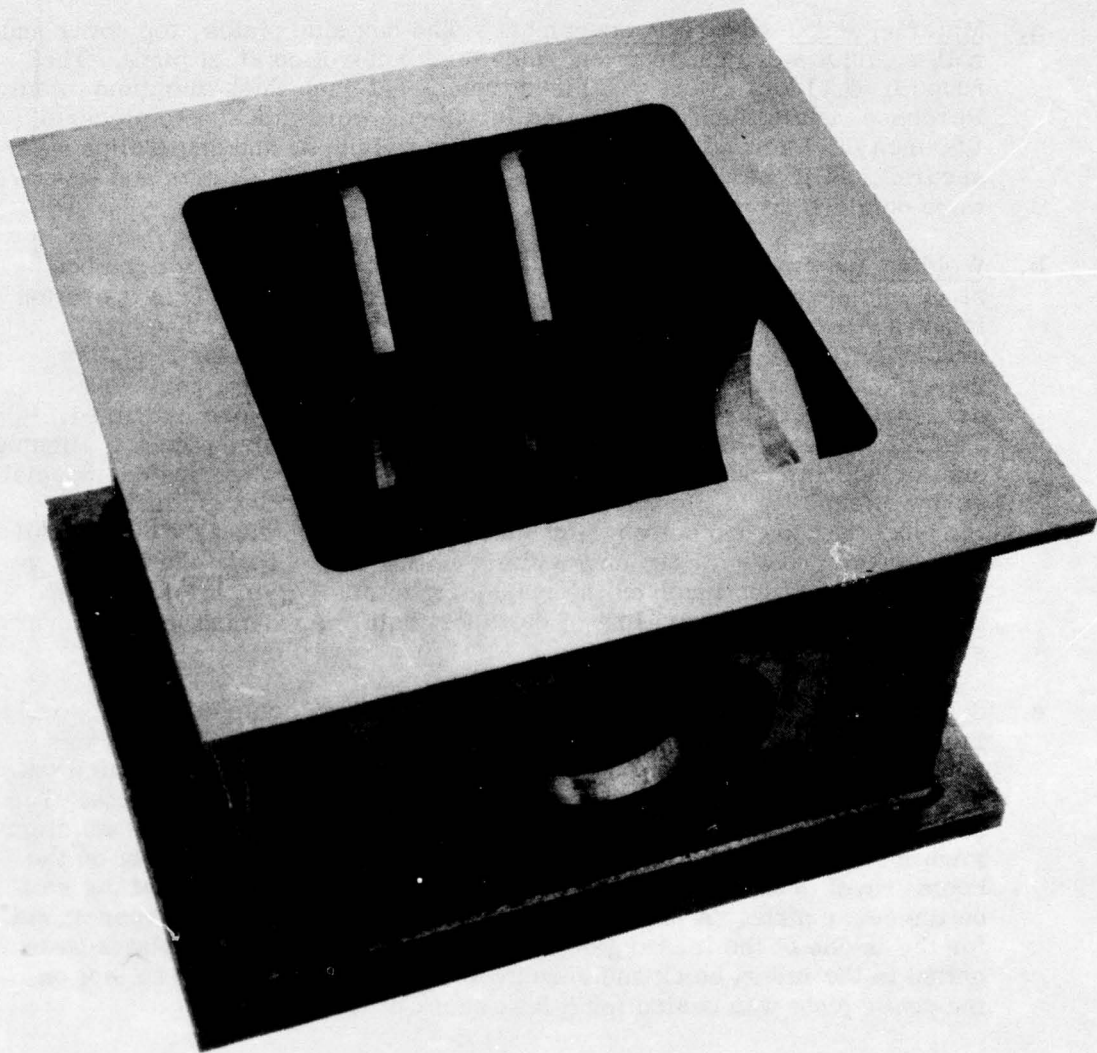

Figure 47 Special Shapes Welding Chamber

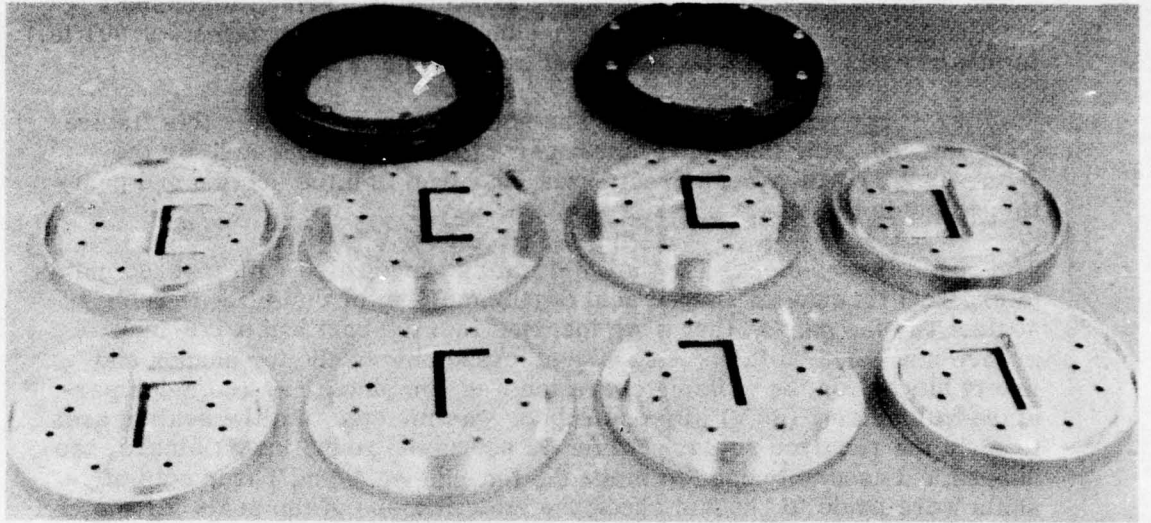

Figure 48 Special Shapes Fixture Inserts and Roller Guides

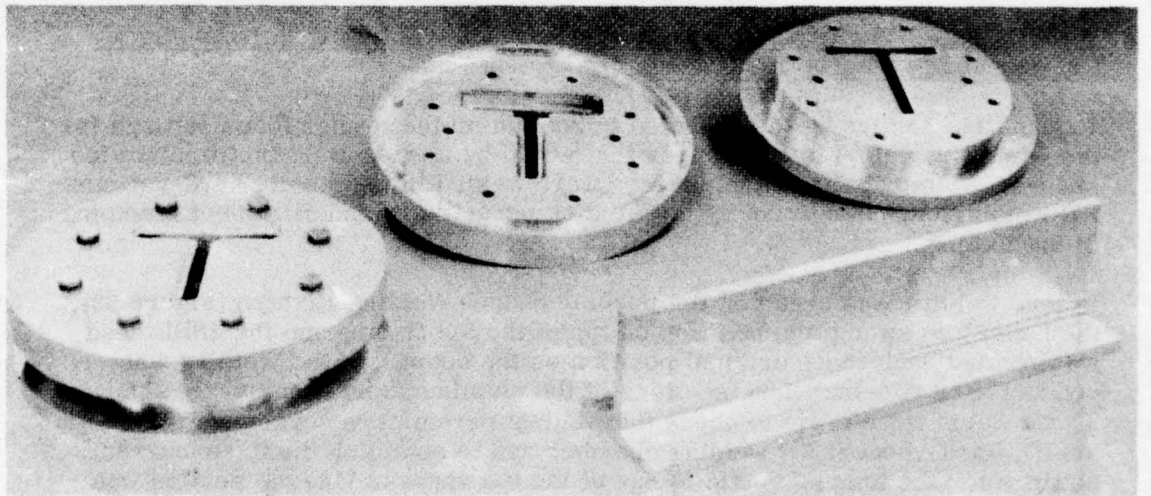

Figure 49 Round Insert Parts and Tee Shape

- d. Fabrication of Aluminum and Titanium Tee Shapes - Tee sections were made from 0.660-inch thick Ti-6Al-4V titanium alloy plate and 0.750-inch thick 2014-T651 aluminum alloy plate that was used on the previous SSEB welding program. These sections were machined (Figure 50) EB welded in the small hard-vacuum EB welder and machined to final dimensions (Figure 51). The tee angles were machined to close tolerances ( $\pm 0.001$  in.) to insure exact part setup, alignment and vacuum sealing.
- e. Molding of Special-Shape Seals - The special-shape seals for this fixture were molded using the round insert parts that were fabricated for the fixture. A 1/8-inch-deep groove was machined in a tee section and positioned inside the insert part.

The round insert-blocks for the weld fixture were fitted with tapered shims to create a triangular-shaped seal during molding of the silicone rubber seals. The tee shapes that were inserted into the part had a 1/8-inch groove machined on the butting edges. Assembly of the tee shapes and insert blocks for the molding operation was completed and room-temperature-vulcanizing (RTV) silicone rubber was injected into the sealing area to form the required seals. Figure 52 shows the round insert blocks, tee shapes and assembly used to make the tee-shaped seals. Three sets of seals were made to vacuum check the effectiveness of the seals for the Special-Shapes Welding Fixture.

Two titanium tee sections were inserted in the fixture. Seals molded from room-temperature-vulcanizing, RTV-631 silicone rubber were inserted in the round end-blocks. The tee shapes were fixtured for a simulated welding operation. RTV-731 silicone rubber was used to seal the outer edges of the tee shapes because the tees were slightly undersized for the aluminum end-blocks. A vacuum level of 20 microns was obtained without difficulty. The fixture was deemed ready for welding.

- f. Welding Tasks Performed on the Special-Shapes Welding Fixture to Check-Out and Verify the Tooling Concept

Parametric studies were conducted to determine the proper focus settings for the various gun-to-work distances that would be used to weld the titanium tee shapes. Aluminum and titanium tees were welded in the small, hard-vacuum EB welding chamber to verify the welding parameters and alignment clamping of the tooling.

Before welding was begun on the Special-Shapes Welding Fixture (Figure 53), the boom was swung into position on top of the tee fixture and the SSEB head was rotated back to its original position on the boom. Initial welding was conducted on two-inch-long sections of the aluminum and titanium tee shapes. These welds were made to check the welding parameters developed in the small, hard-vacuum EB welding chamber and to establish the focus current settings for the top and vertical legs of the tee shapes. One tee section was welded from each material. The welding parameters developed for the aluminum tee angles were: beam voltage - 40 kilovolts, beam current - 115 milliamperes, travel speed - 60 inches per minute, and focus current settings of 6.05 amperes for the top leg and 5.90 amperes for the vertical leg.

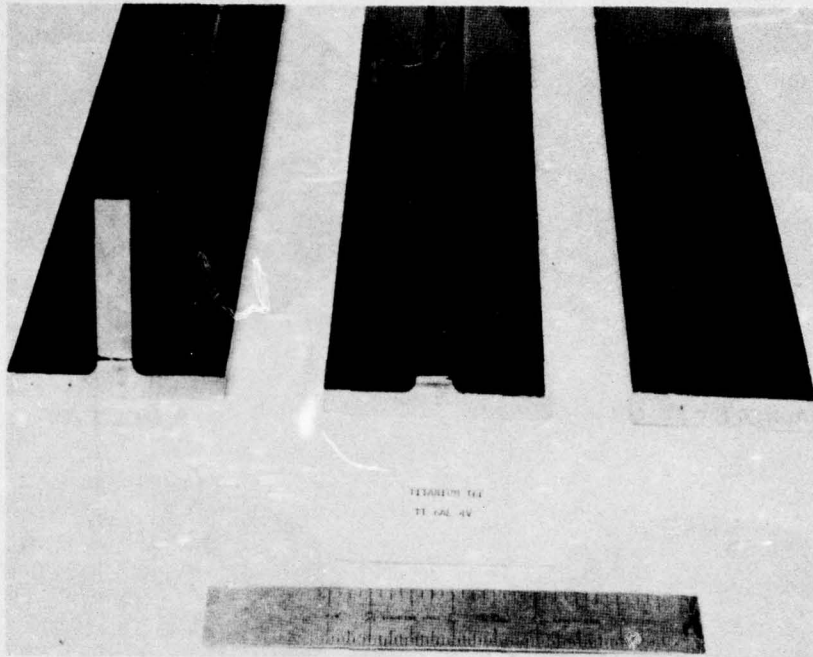

Figure 50 Ti-6Al-4V Titanium Alloy Tee Shapes for Use in Special-Shapes Fixture



Figure 51 2014-T651 Aluminum Alloy Tee Shapes for Use in Special-Shapes Fixture

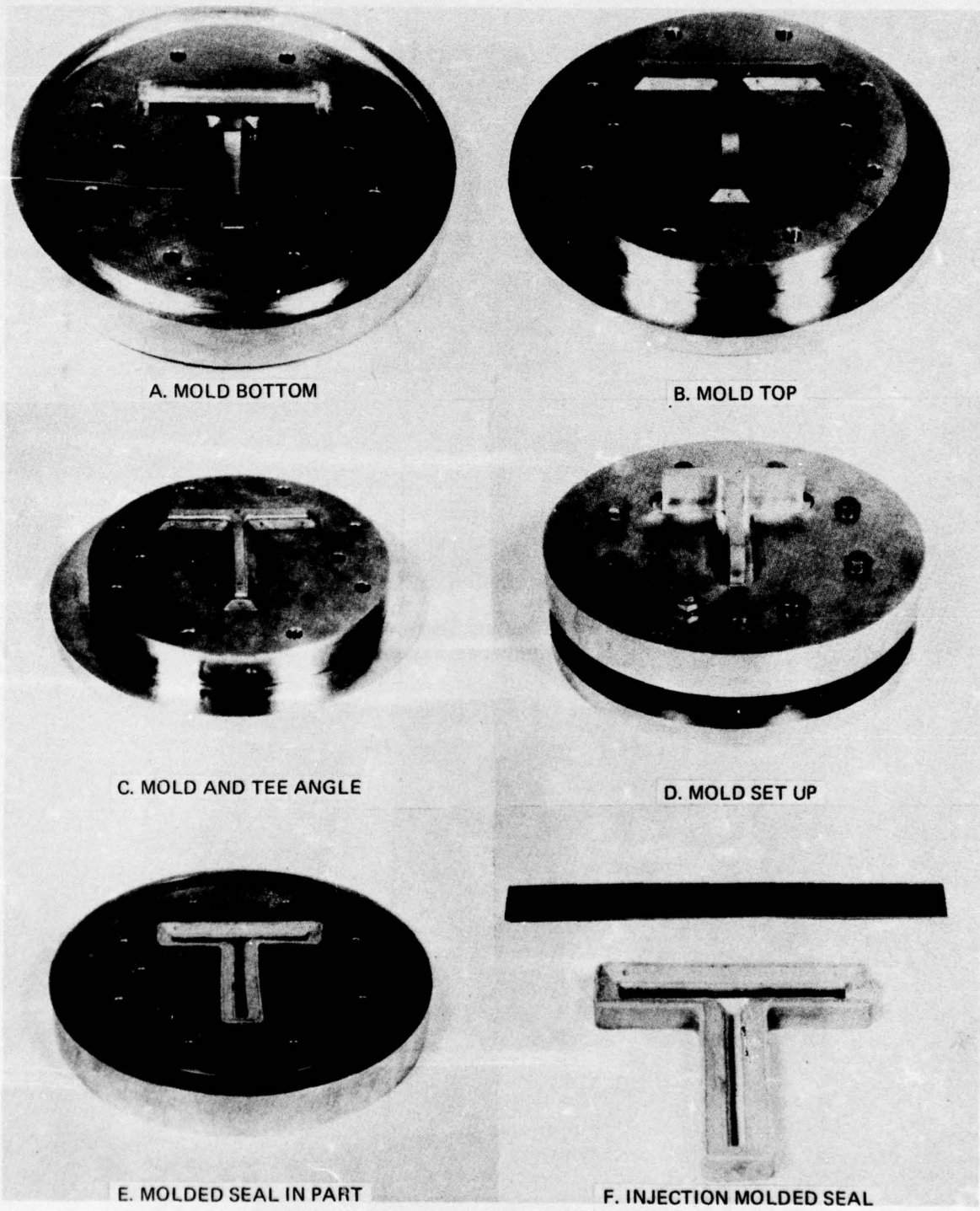

Figure 52 Components Used to Mold Silicone Rubber Tee Seals

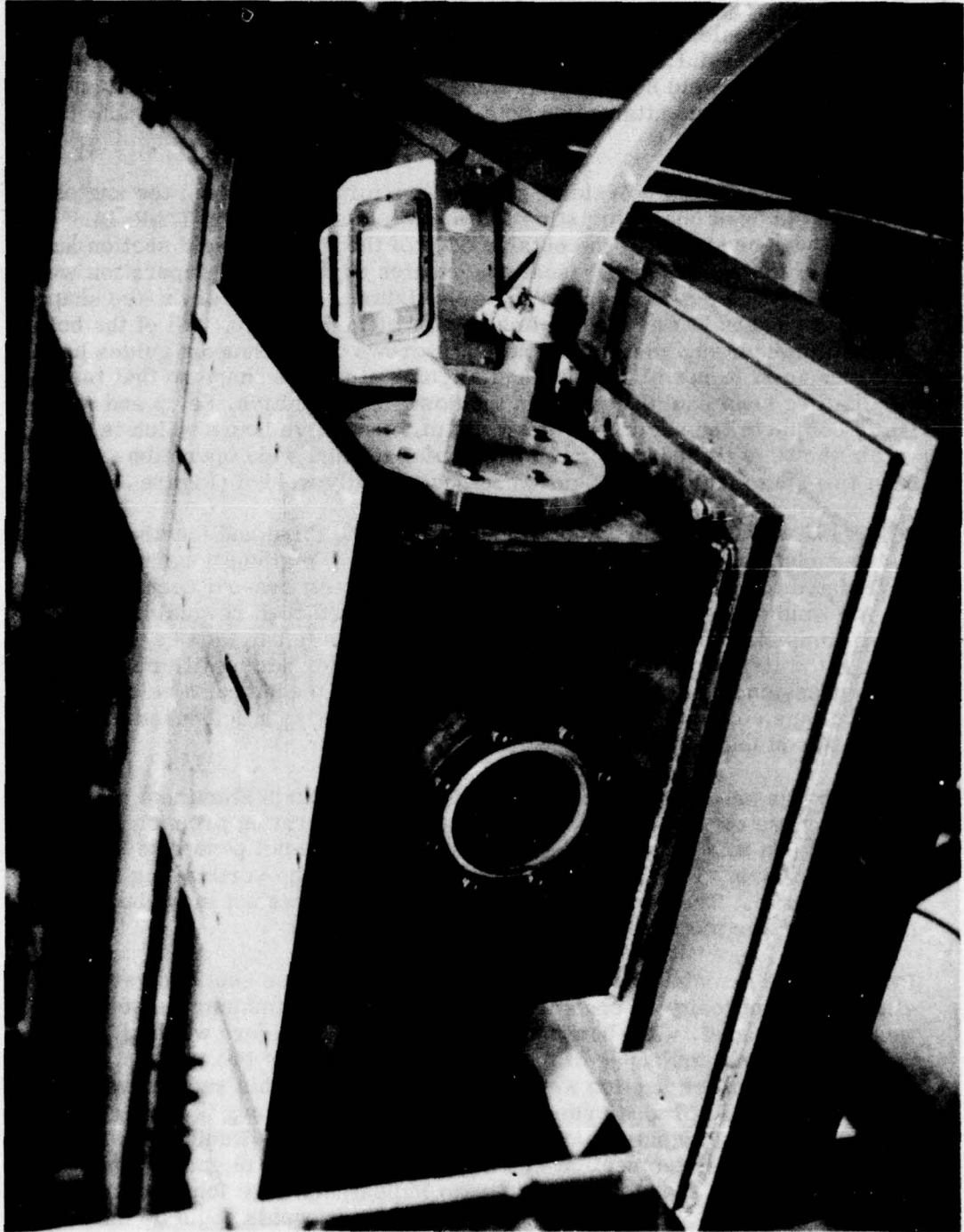

Figure 54 Special Shapes Welding Fixture

Although a change in the focus current setting was necessitated by the different gun-to-work distance required for each weld, the heat input for each weld remained constant at 4.6 kilojoules per inch. The welding parameters used on the titanium tee shapes were: beam voltage - 40 kilovolts, beam current - 250 milliamperes, travel speed - 60 inches per minute, and focus current settings of 6.05 and 5.90 amperes for each weld. The heat input for each weld was constant at 10 kilojoules per inch. Since both the aluminum and titanium tee sections were successful, these parameters were used for all subsequent welding operations. The weld bead shapes were fairly uniform for each weld and adequate penetration was attained on both the top and vertical legs of each material.

- (1) Aluminum Tee Shapes - Welding parameters for the aluminum tee angles and the weld bead characteristics for each weld are listed in Table 16. Prestite was used to seal the outside edge of the first tee weld section and the rest of the weldments. Visual observation of the welding operation was possible through a glass port on the weld fixture. Rotation of the tee shapes for the second weld was accomplished with little difficulty. All of the bolts on the aluminum end plates and the jack screws on the support guides had to be loosened to permit turning and aligning of the tee shape so that the vertical leg weld could be made in the down-hand position. Setup and welding of complete tee sections were made in four to five hours which is within the time period required for cleaning to final weld operations. The first two aluminum tee sections were successfully welded (Figure 54).

Problems were encountered during welding of the third and fourth aluminum tee shapes. This was attributed to equipment malfunctions and were not related to any tooling or welding conditions. An arc-out occurred on the top weld of the third aluminum tee section. Although rewelding of the seam completed the weld, a slight depression was left in the arc-out void area of the first weld. No provisions were made for adding filler metal to the depression. On the vertical weld of the same tee shape, a relay on the high-voltage control failed to operate. Consequently, a defocused weld was made on the part.

Problem was encountered on the next weld on the fourth aluminum tee section. Because the focus current control was not operating properly, the weld made on this part was widely defocused and did not penetrate the top of the tee shape. This wide weld on the top caused the vertical leg to open up at the base. The vertical leg weld of this angle was not made because the opening was too wide for proper welding.

Radiographic examination of the first two aluminum tee sections revealed slight linear porosity on each of the welds. These aluminum tee sections were acid-cleaned, wire-brushed and alcohol-wiped before welding. In order to evaluate the cause of the linear porosity in the two tee sections, a fifth aluminum tee section was set up and welded. This section was acid-cleaned and hand scraped prior to welding. Hand scraping is required for all 2000-series aluminum material that is GTA welded. Radiographic examination of this tee section was satisfactory. A 0.010-inch-diameter pore was found on the top weldment. No indications were found on the vertical leg weld. This indicated that satisfactory welds could be made on aluminum tee sections, if proper cleaning and tooling set-up procedures are followed.

TABLE 16. SSEB WELDING PARAMETERS AND RESULTS FOR BUTT WELDS MADE ON 0.300-INCH-THICK 2014-T651 ALUMINUM ALLOY TEE ANGLES

| Weld No.                 | Beam Voltage, kv | Beam Current, ma | Focus Current, amp | Travel Speed, ipm | Heat Input, kj/in. | Results                             |           |                |                                     |            |            |                                |       |       |
|--------------------------|------------------|------------------|--------------------|-------------------|--------------------|-------------------------------------|-----------|----------------|-------------------------------------|------------|------------|--------------------------------|-------|-------|
|                          |                  |                  |                    |                   |                    | Top Surface                         |           |                | Underfill, in.                      |            |            | Under Bead                     |       |       |
|                          |                  |                  |                    |                   |                    | Shape                               | Width, in | Underfill, in. | Shape                               | Width, in. | Depth, in. |                                |       |       |
| Tee 1<br>Top<br>Vertical | 40               | 115              | 6.05               | 60                | 4.6                | Very Uniform                        | 0.135     | 0.008          | Uniform                             | 0.085      | 0.045      |                                |       |       |
|                          | 40               | 115              | 5.90               | 60                | 4.6                |                                     | 0.130     |                |                                     | 0.010      |            | Uniform                        | 0.085 | 0.046 |
| Tee 2<br>Top<br>Vertical | 40               | 115              | 6.05               | 60                | 4.6                | Very Uniform                        | 0.1300    | 0.017          | Uniform                             | 0.085      | 0.038      |                                |       |       |
|                          | 40               | 115              | 5.90               | 60                | 4.6                |                                     | 0.130     |                |                                     | 0.014      |            | Uniform                        | 0.083 | 0.043 |
| Tee 3<br>Top<br>Vertical | 40               | 115              | 6.05               | 60                | 4.6                | Defocused weld, partial penetration |           |                | Defocused weld, partial penetration |            |            |                                |       |       |
|                          | 40               | 115              | 5.90               | 60                | 4.6                |                                     |           |                |                                     |            |            | Defocused weld, no penetration |       |       |
| Tee 4<br>Top<br>Vertical | 40               | 115              | 6.05               | 60                | 4.6                | Defocused weld, no penetration      |           |                | Defocused weld, no penetration      |            |            |                                |       |       |
|                          | No weld          | —                | —                  | —                 | —                  |                                     |           |                |                                     |            |            |                                |       |       |
| Tee 5<br>Top<br>Vertical | 40               | 115              | 6.05               | 60                | 4.6                | Uniform                             | 0.105     | 0.015          | Uniform                             | 0.095      | 0.035      |                                |       |       |
|                          | 40               | 115              | 5.90               | 60                | 4.6                |                                     | 0.125     |                |                                     | 0.010      |            | Uniform                        | 0.095 | 0.045 |

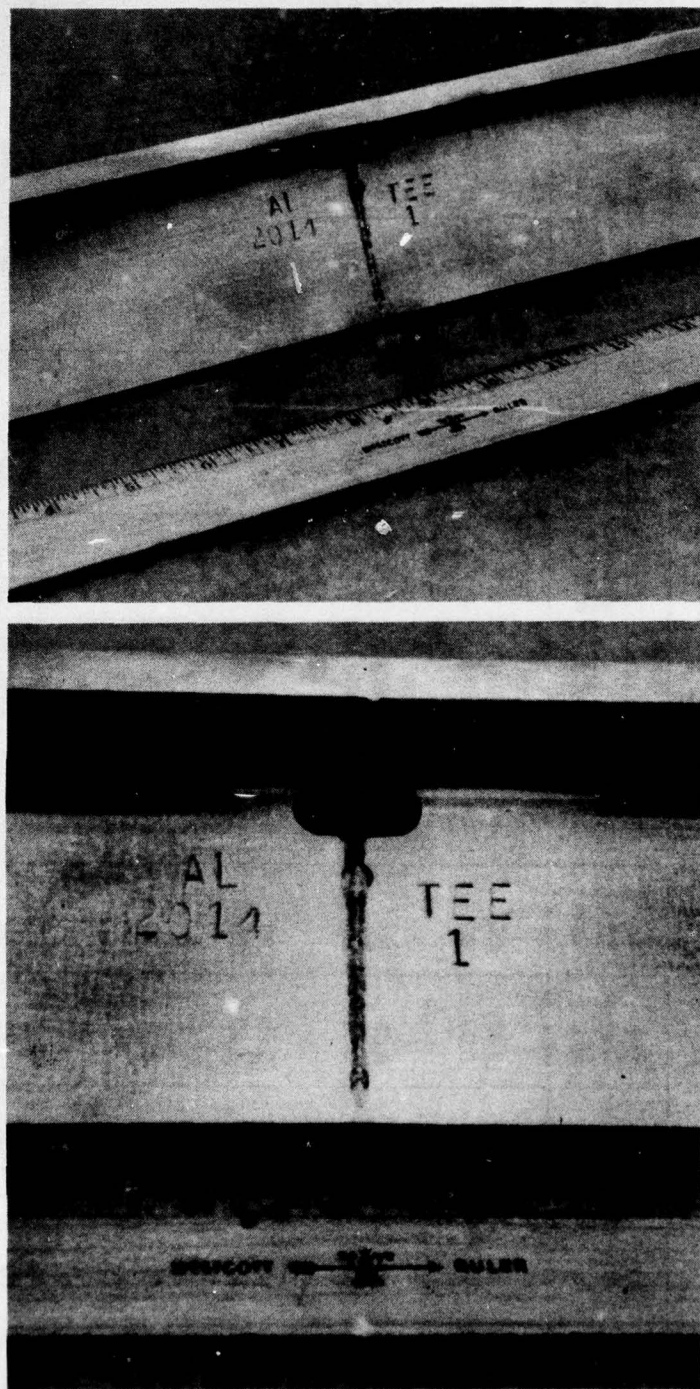

Figure 54 SSEB Butt Weld Made on 0.300-inch-Thick 2014-T651 Aluminum Alloy Tee Shape

(2) **Titanium Tee Shapes** - The welding of four Ti-6Al-4V titanium alloy tee sections was accomplished without any equipment or welding problems. All of the weldments had the same surface bead and penetration characteristics. The bead shapes and welding parameters are listed in Table 17. A cosmetic pass was performed on the first titanium tee to evaluate the effect of a partial penetrating weld made on a part in this particular fixture set-up and to eliminate the slight underfill condition at the edges of the weld. All four of the titanium tee sections passed radiographic requirements.

g. **Weld Fixture Evaluation** - Program requirements were to weld three special shapes in the special shapes weld fixture. Nine shapes were successfully welded during the course of the welding program. The five aluminum and four titanium tee shapes were fabricated and visually and radiographically inspected. These weldments which satisfied program requirements demonstrated equipment capability to join complex shapes. Injection molded silicone rubber seals were used to vacuum seal the tee sections inside the weld fixture/chamber which eliminated the requirements for the GTA sealing pass operation.

#### 4. Preheat Steel Welding Fixture

This welding chamber, which is 56 inches long, 24 inches wide, and 8-1/2 inches high, can be used to make welds up to 24 inches long. Steel parts to be welded are brought up to and maintained at the preheat temperature by electrical heating units.

a. **Material and Hardware Procurement** - The box structure and fixture support assemblies inside the vacuum box were made from hot-rolled steel plate. The coverplate for the fixture was fabricated from one-inch-thick 7075-T6 aluminum alloy plate. Special items purchased for the preheating operation included O-ring cord stock, iron-constantan thermocouple wire, eight Watlow Firerod heating cartridges, and two Veeco 220-volt/60 ampere feedthrough connectors.

Other items essential to the operation of the Preheat Steel Welding Fixture were obtained from Company stock. This included a 220 volt/60 ampere line service and fuse box, Variac power supply, Barber Colman controller, and a Bristol 8-channel strip chart recorder (0° to 600°F range), and the miscellaneous items such as nuts, bolts, washers and dowel pins etc. were also requisitioned from Company stock.

b. **Welding and Machining of Fixture** - The box structure and the detailed parts and support assembly were welded. The bottom plate and four side walls of the box structure were welded inside and outside which caused the fixture to bow approximately 1/4-inch in the center. The box was flattened in an arbor press which removed part of the distortion. A further hot flattening in a 1200°F press was required to flatten the box so that the top flange plate could be welded into place. The box was held at 1200°F for several hours to stress relieve the fixture and eliminate any spring-back that might have occurred when the fixtures were removed from the press. The flange plate was welded flat to the box sides, then the lower "O"-ring groove was machined in the top surface. The cover plate for the fixture sealed against the top of the flange.

TABLE 17. SSEB WELDING PARAMETERS AND RESULTS FOR BUTT WELDS MADE ON 0.300-INCH-THICK Ti-6Al-4V TITANIUM ALLOY TEE ANGLES

| Weld No.   | Beam Voltage, kv | Beam Current, ma | Focus Current, amp | Travel Speed, ipm | Heat Input, kj/in. | Results      |            |               |               |            |            |            |       |
|--|------------------|------------------|--------------------|-------------------|--------------------|--------------|------------|---------------|---------------|------------|------------|------------|-------|
|  |                  |                  |                    |                   |                    | Top Surface  |            |               | Underfill in. |            |            | Under Bead |       |
|  |                  |                  |                    |                   |                    | Shape        | Width, in. | Underfill in. | Shape         | Width, in. | Depth, in. |            |       |
| Tee 1<br>Top<br>Cosmetic<br>Pass<br>Vertical<br>Cosmetic<br>Pass | 40               | 250              | 6.05               | 60                | 10.0               | Uniform      | 0.275      | -             | Uniform       | 0.080      | 0.053      |            |       |
|  | 40               | 50               | 6.50               | 40                | 0.2                | Slight Crown |            |               |               |            |            |            |       |
|  | 40               | 250              | 5.90               | 60                | 10.0               | Uniform      |            |               |               |            |            |            |       |
|  | 40               | 50               | 6.30               | 40                | 0.2                | Slight Crown |            |               |               |            |            |            |       |
| Tee 2<br>Top<br>Vertical   | 40               | 250              | 6.05               | 60                | 10.0               | Uniform      | 0.135      | Light crown   | Uniform       | 0.065      | 0.035      |            |       |
|  | 40               | 250              | 5.90               | 60                | 10.0               | Uniform      |            |               |               |            |            | 0.145      | 0.075 |
| Tee 3<br>Top<br>Vertical   | 40               | 250              | 6.05               | 60                | 10.0               | Uniform      | 0.135      | 0.010 crown   | Uniform       | 0.065      | 0.035      |            |       |
|  | 40               | 250              | 5.90               | 60                | 10.0               | Uniform      |            |               |               |            |            | 0.145      | 0.075 |
| Tee 4<br>Top<br>Vertical   | 40               | 250              | 6.05               | 60                | 10.0               | Uniform      | 0.130      | 0.010 crown   | Uniform       | 0.075      | 0.030      |            |       |
|  | 40               | 250              | 5.90               | 60                | 10.0               | Uniform      |            |               |               |            |            | 0.155      | 0.075 |

The top surface of the flange plate and bottom surface of the box were machined flat and parallel. The support bar assemblies for the weld fixture were welded and also hot flattened and stress relieved. The support bars were aligned and assembled inside the vacuum box. The center bars that contain the heating elements and provide the flat surface for the weld plate material were machined.

The box structure was checked with a dye-penetrant as a precautionary measure to locate any weld cracks or surface flaws. Necessary repairs were accomplished at this point. The final assembly operation was completed when the heating elements and hold-down parts were bolted into the fixture. The fixture was sealed with a 1/2-inch-thick aluminum plate and checked for vacuum leaks. After repairing several small leaks, the fixture was held at the required 5 to 10-micron vacuum level.

- c. Set-Up and Instrumentation of Fixture in the SSEB Welding Room - The Preheat Steel Welding Fixture (Figure 55) was set up on the weld table adjacent to the SSEB welder and aligned with the X-axis (boom travel direction). The preheating equipment and temperature recording thermocouples were then installed. Figure 56 shows the fixture used for welding 0.880-inch-thick HY 130 steel plate. Two Veeco 220-volt/60 ampere feed-through connectors were adapted to the fixture wall. Watlow Firerod heating elements were connected in series to a Variac controller. Eight thermocouple wires were sealed to the fixture with an epoxy sealant and connected to a strip chart recorder capable of monitoring temperature over a 0° to 600°F range. A control thermocouple wire was also potted to the fixture and connected to a Barber Colman controller that regulated the output power of the 220-volt/60-ampere power supply Variac.
- d. Heating Studies Performed in Fixture - Tests were made to determine the heatup rates of the fixture and the one-inch-thick steel plate. Tests were run with the Variac at different settings and with the fixture open to air and under vacuum for welding. Figure 57 shows typical heatup rates for the fixture in air and for the plate under vacuum. Temperatures indicated by the recorder were monitored in several places (three on the top and three on the bottom) and then averaged. A slight difference in temperature (10°F - 20°F) noted between the controller and the strip chart recorder was probably caused by the use of different thermocouple wire and different locating positions on the plate. During the course of the program, the heating elements were connected in parallel to preheat the plates at a more rapid rate and to maintain a more uniform plate temperature. Figure 58 shows the time and temperature readings for heatup of a one-inch-thick steel plate with the Variac at different settings and with the fixture open. A No. 5 Variac setting with a 100-volt/11-ampere input was found to be superior and was used for the remainder of the heating studies.
- e. Welding Tasks Performed in Preheat Steel Welding Fixture to Check-Out and Verify Tooling Concept - The concept of sliding the seals on a steel sheet and making a weld through a cover sheet was not used on this fixture because the slot welding technique developed for welding wing beams on an in-house program had proven to be a more satisfactory method of welding in a

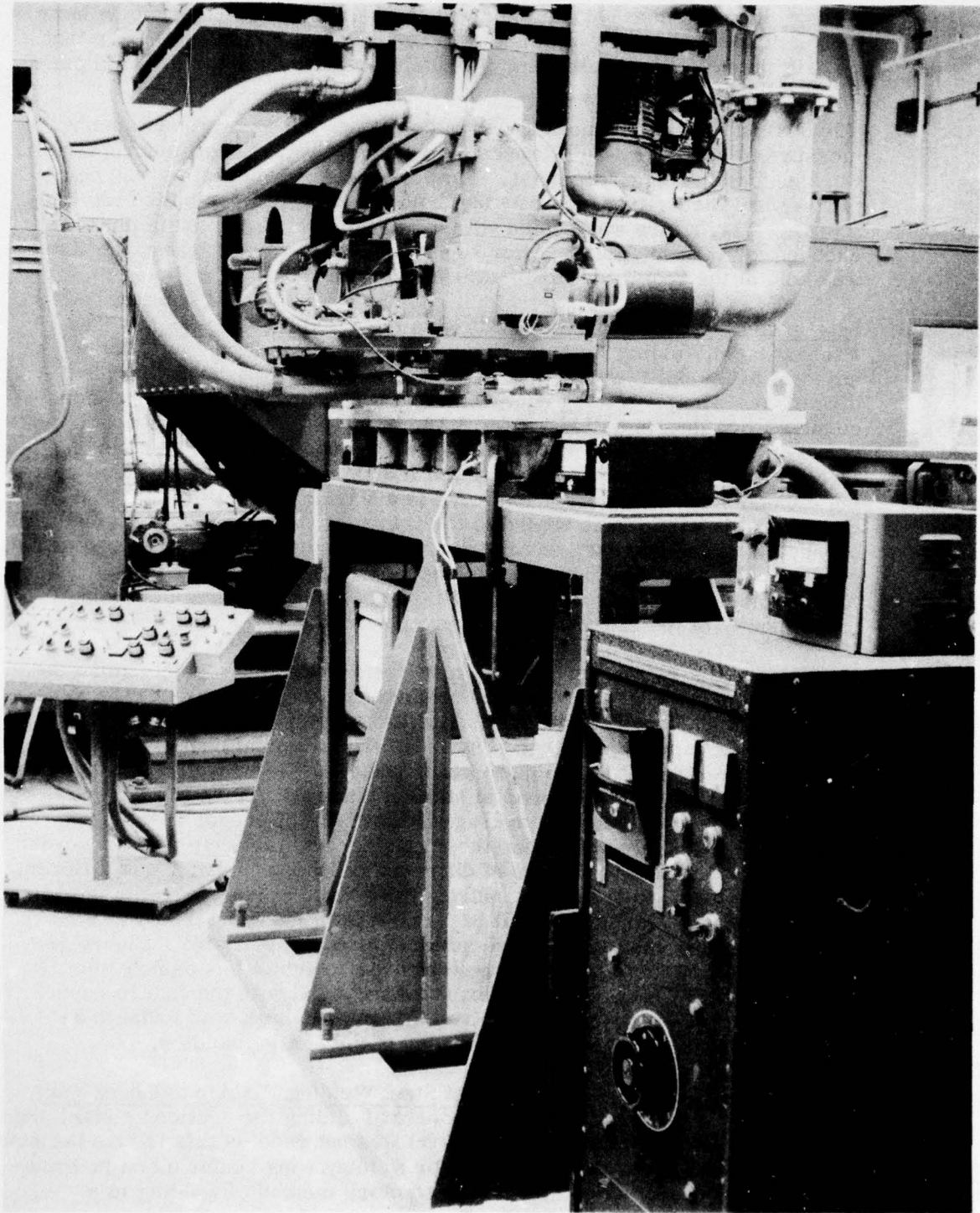

Figure 55 Preheat Steel Welding Fixture

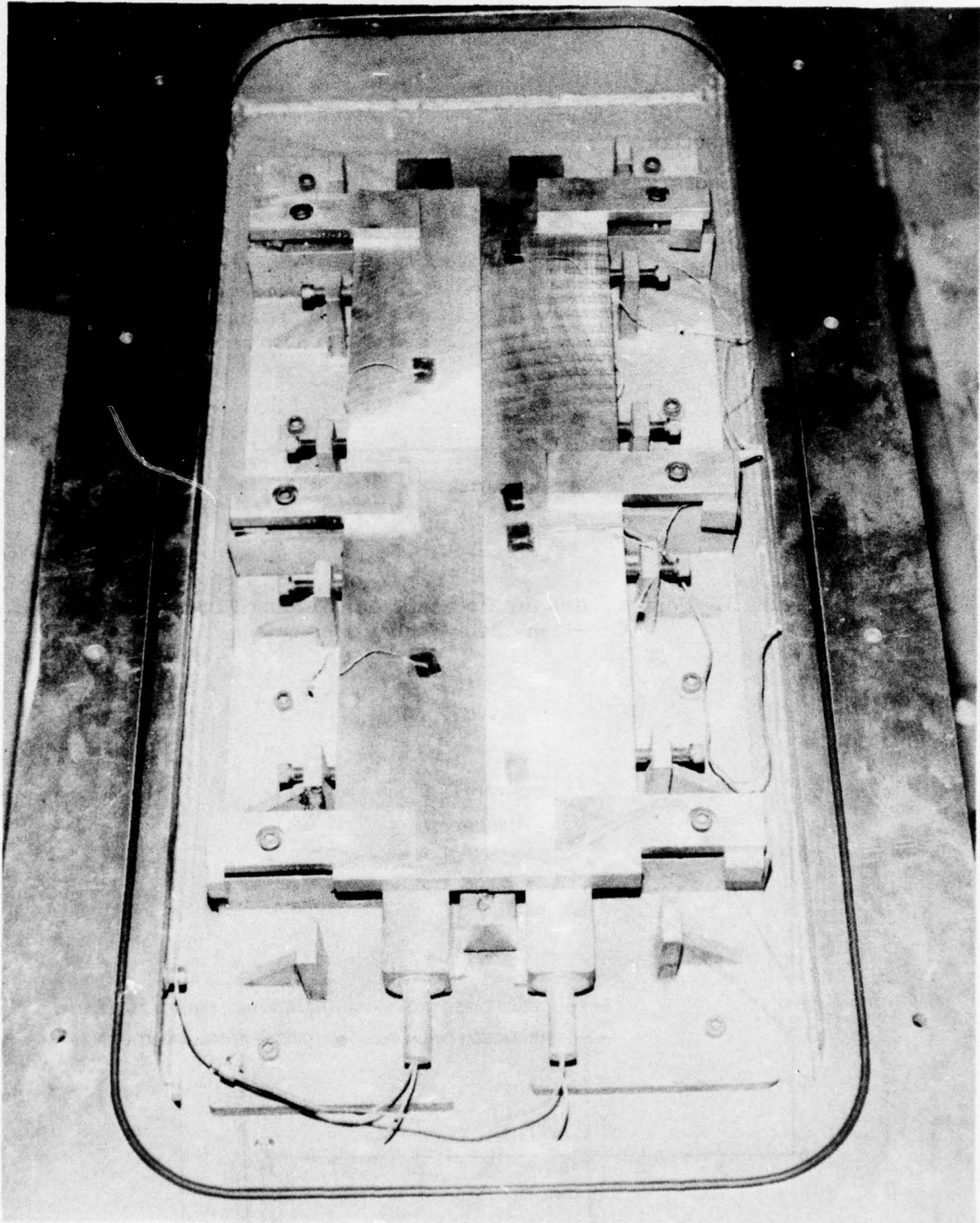

Figure 56 Fixture Used to SSEB-Weld 0.880-inch-Thick HY 130 Steel Plate

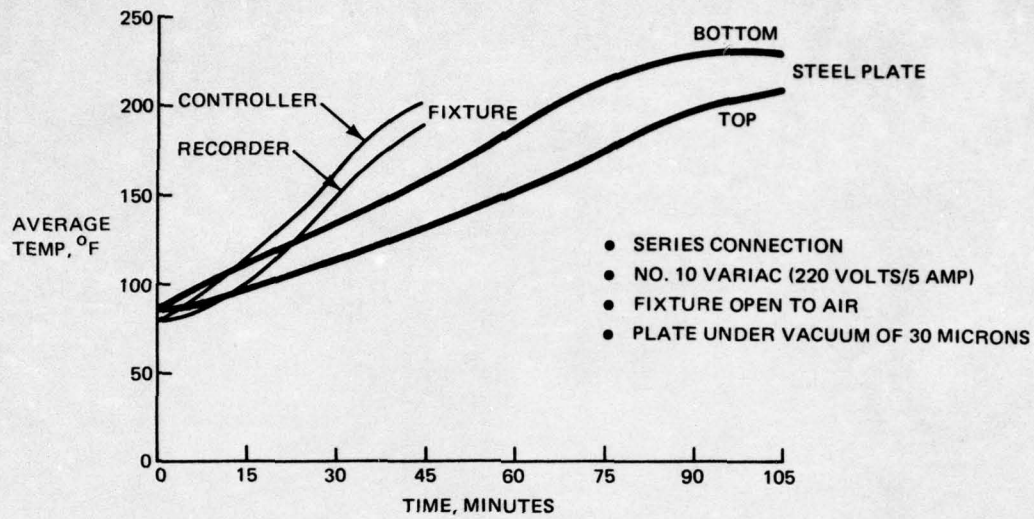

Figure 57 Heatup Rates for Preheat Steel Welding Fixture and One-Inch-Thick Steel Plate

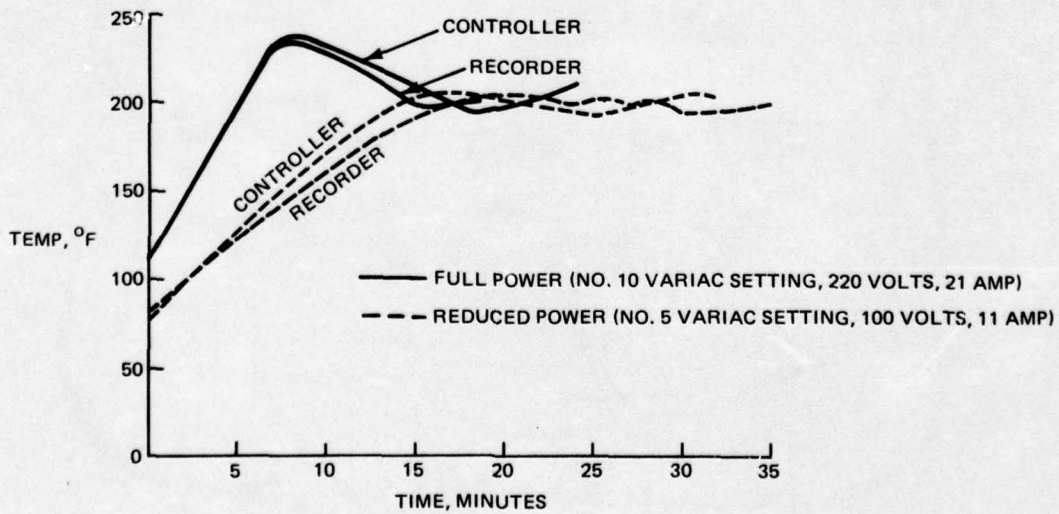

Figure 58 Steel Plate Preheating Rates with Parallel Connection and Fixture Open to Air

vacuum box. Therefore, a one-inch-thick 7075-T6 aluminum alloy plate was machined to give a 30-inch-long by a two-inch-wide slot and O-ring groove. This plate was used on the Preheat Steel Welding Fixture for slot welding and replaced the original steel top plate on the fixture. After the fixture was set up and aligned on the welding table, bead-on-plate welds were made on 1/2-inch-thick 4130 steel plate to check weld seam alignment, fixture alignment and clamping, and to evaluate slot welding techniques inside a vacuum chamber.

Since 1/2-inch-thick HY 130 and D6AC steel plates were successfully welded on the previous SSEB weld program without preheating, it was decided to make several butt welds in this material without preheating in order to compare the results of slot welding to that for welds made on the last program. The two welds made had the same general bead shape and penetration obtained previously. Welding parameters and bead description for the bead-on-plate parameter development and butt welds on -0.440-inch-thick plate are listed in Table 18.

- (1) HY 130 Steel Welding - The first butt weld made in one-inch-thick HY 130 steel was accomplished without any preheating to check the weld parameters on this material. The second and third butt welds were made on HY 130 steel to evaluate restraint conditions that may have caused cracking in the weld during the original program. Start and stop end-tabs were manually welded to the weld coupons to simulate the method used to GTA seal the weldments in previous work. These two welds were not preheated.

The fourth, fifth and sixth butt welds were made using the preheating equipment. Figure 43 shows the typical weld setup used to preheat the plates for welding and the thermocouple wires attached to the weld plate. The controller was set at 200°F for the HY 130 steel welding tests. Fairly uniform temperatures were held and recorded for each of the weldments. The welding parameters and results of the welding on HY 130 steel plate are presented in Table 19. The 200°F temperature cycle for HY 130 steel was selected because the minimum and maximum temperature for welding one-inch-thick HY 130 steel are 150°F and 300°F. Radiographic examination of the six weldments showed that the first and second welds were satisfactory. No indications of cracks, bursts or inclusions were found on these welds. The third, fourth, fifth and sixth welds had small (0.075 to 0.100-inch) bursts or center line cracks on the start of each weld. The third and fourth welds also had a second small burst or crack in the middle of the weldment. No other indications were found on the six welds. The burst or cracks at the start of the welds may have been caused by restraint or lower plate temperature on the weld start. Integral start tabs, if used, would have eliminated the defects from the weldment. Tensile specimens were machined from base-metal material and Butt Weld No. 6. Several views of one-inch-thick HY 130 steel plate welded both with and without preheating are shown in Figure 59.

- (2) D6AC Steel Welding - Initial bead-on-plate welds were made on one-inch-thick D6AC steel without preheating to determine welding parameters and focus current settings. Two short butt welds were also made on D6AC steel to check the welding parameters selected.

TABLE 18. SSEB WELDING BEAD-ON-PLATE PARAMETERS AND RESULTS FOR WELDS MADE ON 0.440-INCH-THICK PLATE

| Weld No. | Beam Voltage, kv | Beam Current, ma | Focus Current, amp | Travel Speed, ipm | Heat Input, kj/in. | Results        |               |                     |               |            |            |            |  |  |
|----------|------------------|------------------|--------------------|-------------------|--------------------|----------------|---------------|---------------------|---------------|------------|------------|------------|--|--|
|          |                  |                  |                    |                   |                    | Top Surface    |               |                     | Underfill in. |            |            | Under Bead |  |  |
|          |                  |                  |                    |                   |                    | Shape          | Width, in.    | Underfill in.       | Shape         | Width, in. | Depth, in. |            |  |  |
| BOP 1    | 45               | 250              | 6.10               | 45                | 15.0               | High Crown     | 0.115         | 0.030 - 0.050 Crown | Narrow        | 0.060      | 0.030      |            |  |  |
| BOP 2    | 45               | 250              | 6.00               | 45                | 15.0               | High Crown     | 0.110 - 0.115 | 0.020 - 0.040 Crown | Narrow        | 0.060      | 0.035      |            |  |  |
| BOP 3    | 45               | 250              | 6.20               | 45                | 15.0               | Defocused Weld | 0.110 - 0.115 | 0.030 - 0.050 Crown | Uneven        | 0.065      | 0.050      |            |  |  |
| BOP 4    | 45               | 275              | 6.10               | 45                | 16.5               | Fair           | 0.110 - 0.115 | 0.020 - 0.060 Crown | Light         | 0.060      | 0.040      |            |  |  |
| BOP 5    | 45               | 250              | 6.20               | 50                | 13.5               | Fair           | 0.110 - 0.115 | 0.015 - 0.070 Crown | Uneven        | 0.060      | 0.045      |            |  |  |
| BUTT 1   | 45               | 250              | 6.10               | 45                | 15.0               | Uniform        | 0.140         | Flush               | Uniform       | 0.065      | 0.045      |            |  |  |
| BUTT 1   | 45               | 250              | 6.10               | 45                | 15.0               | Very Uniform   | 0.140         | 0.020 Crown         | Very Uniform  | 0.040      | 0.060      |            |  |  |

TABLE 19. SSEB WELDING PARAMETERS AND RESULTS FOR BUTT WELDS MADE ON  
0.880-INCH-THICK HY 130 STEEL PLATE

| Weld No. | Beam Voltage, kv | Beam Current, ma | Focus Current, amp | Travel Speed, ipm | Heat Input kj/in. | Results           |                |                 |                       |            |            |            |  |  |
|----------|------------------|------------------|--------------------|-------------------|-------------------|-------------------|----------------|-----------------|-----------------------|------------|------------|------------|--|--|
|          |                  |                  |                    |                   |                   | Top Surface       |                |                 | Underfill in.         |            |            | Under Bead |  |  |
|          |                  |                  |                    |                   |                   | Shape             | Width, in.     | Underfill in.   | Shape                 | Width, in. | Depth, in. |            |  |  |
| BUTT 1   | 55               | 350              | 6.00               | 40                | 28.8              | Uniform           | 0.160          | 0.010<br>Crown  | Uniform               | 0.085      | 0.080      |            |  |  |
| BUTT 2   | 55               | 350              | 6.00               | 40                | 28.8              | Defocused<br>Weld | 0.375          |                 | Uneven<br>Penetration |            |            |            |  |  |
| BUTT 3   | 55               | 350              | 6.00               | 40                | 28.8              | Uniform           | 0.160<br>0.190 | Slight          | Uneven                | 0.040      | 0.140      |            |  |  |
| BUTT 4   | 55               | 350              | 6.00               | 40                | 28.8              | Uniform           | 0.180          | 0.010<br>Crown  | Uniform               | 0.075      | 0.070      |            |  |  |
| BUTT 5   | 55               | 350              | 6.00               | 40                | 28.8              | Uniform           | 0.190<br>0.210 | Slight<br>Crown | Uniform               | 0.075      | 0.075      |            |  |  |
| BUTT 6   | 55               | 350              | 6.00               | 40                | 28.8              | Uniform           | 0.190          | 0.010<br>Crown  | Uniform               | 0.075      | 0.060      |            |  |  |



TOP SURFACE

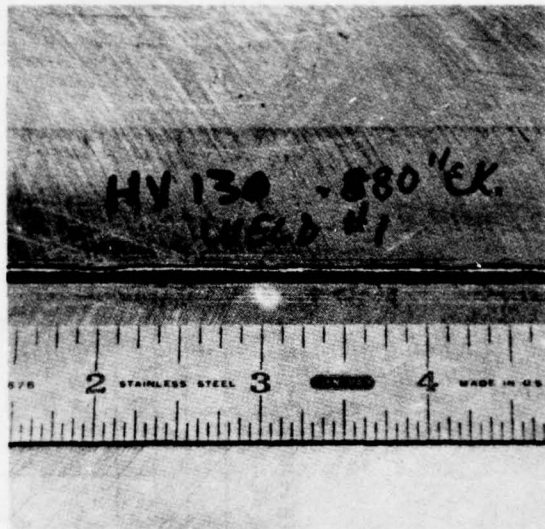

BOTTOM SURFACE

**A. WELD NO. 1—NOT PREHEATED BEFORE WELDING**

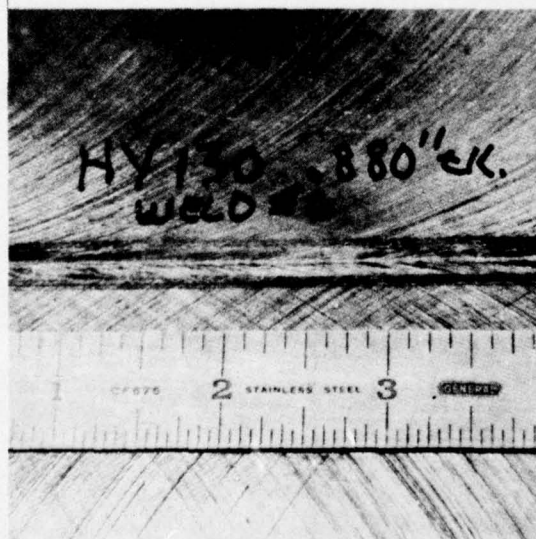

TOP SURFACE

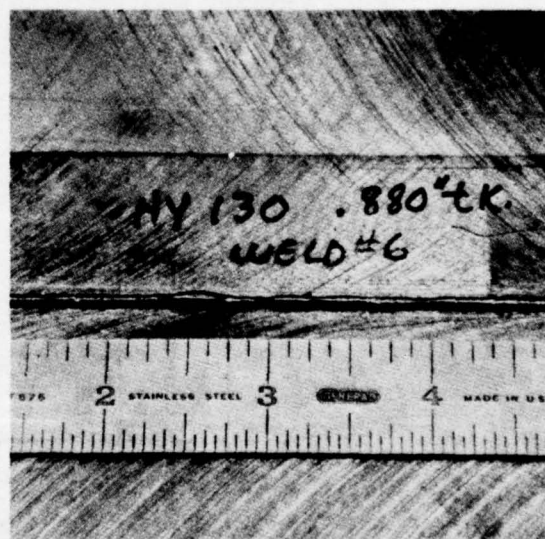

BOTTOM SURFACE

**B. WELD NO. 6—PREHEATED BEFORE WELDING**

Figure 59 0.880-Inch-Thick HY 130 Steel Plate SSEB Welded With and Without Preheating

Welding of D6AC steel was conducted using a preheat temperature of 350°F. This change in preheat temperature was made because standard preheat temperatures for GTA welding are in the 300°F to 400°F range. The third and fourth welds were made at the same temperature (350°F). Both welds had similar bead shapes and penetration. Radiographic examination showed that the weldments were satisfactory. There were no indications of voids, cracks or inclusions. The weld parameters and weld results are presented in Table 20.

- (3) Weld Evaluation - Completion of the steel welding tasks on the preheat steel weld fixture successfully demonstrated that preheating the materials prior to SSEB welding would eliminate internal cracking during and after welding. The unsuccessful attempt on the previous SSEB weld program to make acceptable welds on HY 130 steel material was discontinued when numerous internal cracks were found in several weldments. Magnetic particle inspection of HY 130 and D6AC weldments did not detect any surface flaws (voids or cracks) open to the weld surface. Radiographic inspection of HY 130 steel weldments found small cracks on the start of several welds. The cracks were attributed to the lower plate temperatures on the weld start of each weldment. Typical weld bead macro sections of HY 130 and D6AC welds are shown in Figures 60 and 61. The limited tensile testing reported in Tables 21, 22, 23 and 24 show that welds which have 100% tensile ultimate and yield stresses can be produced using this fixture. The successful use of the slot welding technique on the preheat steel fixture provided a new approach for welding flat plate, extrusions, rib-stiffened panels and angle configurations of various sizes and lengths.

TABLE 20. SSEB WELDING BEAD-ON-PLATE PARAMETERS AND RESULTS FOR WELDS MADE ON ONE-INCH-THICK D6AC STEEL PLATE

| Weld No. | Beam Voltage, kv | Beam Current, ma | Focus Current, amp | Travel Speed, ipm | Heat Input, kj/in. | Results         |                |                   |                   |            |            |            |  |
|----------|------------------|------------------|--------------------|-------------------|--------------------|-----------------|----------------|-------------------|-------------------|------------|------------|------------|--|
|          |                  |                  |                    |                   |                    | Top Surface     |                |                   | Underfill in.     |            |            | Under Bead |  |
|          |                  |                  |                    |                   |                    | Shape           | Width, in.     | Underfill in.     | Shape             | Width, in. | Depth, in. |            |  |
| BOP 1    | 55               | 350              | 6.10               | 45                | 25.7               | Uneven          | 0.130          | High              | Incomplete        |            |            |            |  |
| BOP 2    | 55               | 350              | 6.10               | 40                | 28.8               | Uniform         | 0.150<br>0.100 | Flat<br>0.010     | Heavy,<br>Uniform | 0.110      | 0.100      |            |  |
| BOP 3    | 55               | 350              | 6.00               | 40                | 28.8               | Uniform         | 0.075          | Crown<br>0.020    | Uniform           | 0.115      | 0.065      |            |  |
| BOP 4    | 55               | 350              | 6.20               | 40                | 28.8               | Large<br>Crown  | No Penetration | Defocused Weld    |                   |            |            |            |  |
| BOP 5    | 55               | 350              | 5.90               | 40                | 28.8               | Wide            | 0.140          | 0.020             | Fair              | 0.085      | 0.075      |            |  |
| BUTT 1   | 55               | 350              | 6.00               | 40                | 28.8               | Uniform<br>Fair | 0.135          | Crown<br>0.010    | Uniform           | 0.085      | 0.055      |            |  |
| BUTT 2   | 55               | 250              | 6.00               | 40                | 28.8               | Uniform         | 0.135          | Mismatch<br>0.015 | Uniform           | 0.085      | 0.075      |            |  |
| BUTT 3   | 55               | 350              | 6.00               | 40                | 28.8               | Uniform         | 0.175          | Crown<br>0.010    | Uniform           | 0.090      | 0.075      |            |  |
| BUTT 4   | 55               | 350              | 6.00               | 40                | 28.8               | Very<br>Uniform | 0.175          | 0.010             | Uniform           | 0.075      | 0.090      |            |  |

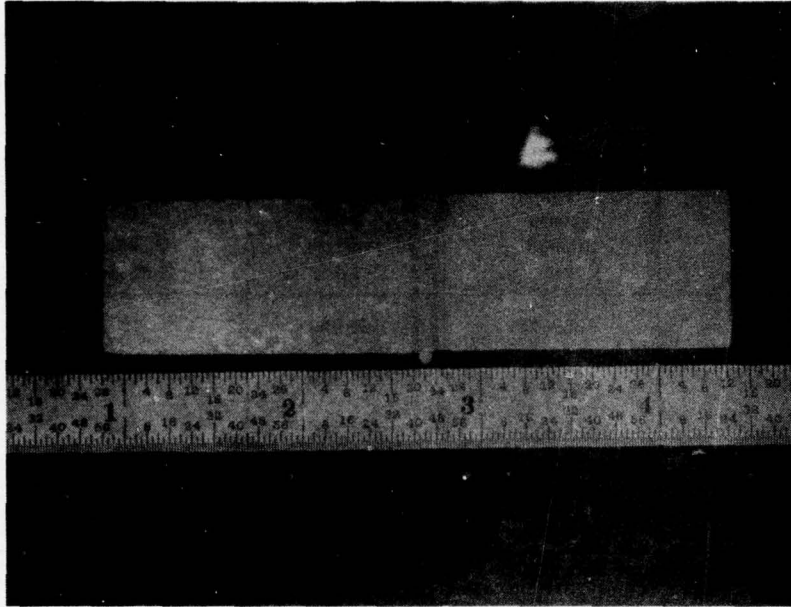

Figure 60 Macro-Section of HY 130 Steel Butt Weld  
Preheated Before Welding (1 X MAG)

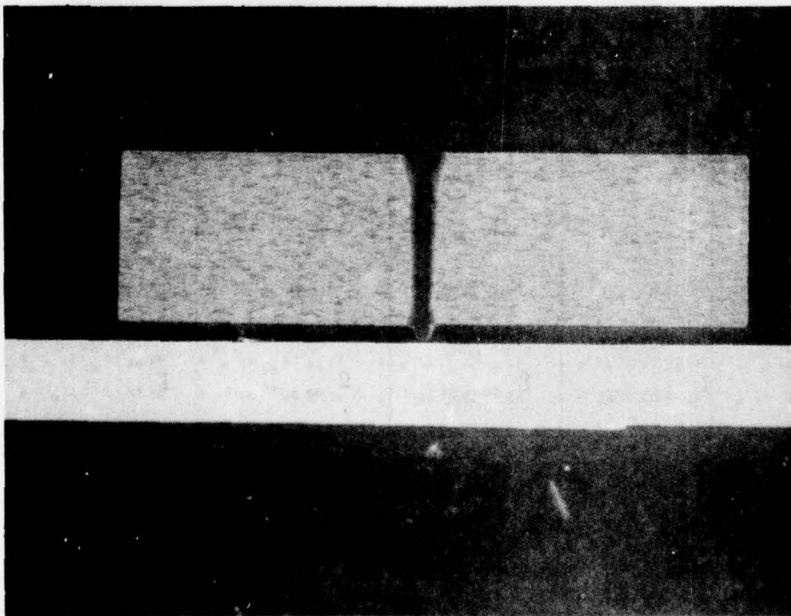

Figure 61 Macro-Section of D6AC Steel Butt Weld  
Preheated Before Welding (1 X MAG)

TABLE 21. TENSILE PROPERTIES OF 0.880-INCH-THICK HY 130 STEEL ALLOY  
BASE PLATE

| Specimen | Ultimate<br>Tensile<br>Strength,<br>ksi | Yield<br>Tensile<br>Strength,<br>ksi | Elongation In<br>Two Inches, % |
|----------|---|--------------------------------------|--------------------------------|
| 1HYB-1   | 138,400                                 | 131,900                              | 19.5                           |
| 1HYB-2   | 137,700                                 | 131,500                              | 19.5                           |
| 1HYB-3   | 137,800                                 | 131,700                              | 17.0                           |
| Ave.     | 138,000                                 | 131,700                              | 18.67                          |

TABLE 22. TENSILE PROPERTIES OF 0.880-INCH-THICK HY 130 STEEL ALLOY BLATE  
SQUARE BUTT JOINT, FLAT POSITION, PREHEATED TO 200°F BEFORE WELDING

| Specimen | Ultimate<br>Tensile<br>Strength,<br>ksi | Yield<br>Tensile<br>Strength,<br>ksi | Elongation In<br>Two Inches, % | Failure<br>Location |
|----------|---|--------------------------------------|--------------------------------|---------------------|
| 1HYW-1   | 139,500                                 | 132,000                              | 18.5                           | Base Metal          |
| 1HYW-2   | 140,600                                 | 133,100                              | 18.5                           | Base Metal          |
| 1HYW-3   | 141,200                                 | 133,100                              | 19.5                           | Base Metal          |
| 1HYW-4   | 141,200                                 | 132,900                              | 19.5                           | Base Metal          |
| 1HYW-5   | 140,000                                 | 132,000                              | 19.5                           | Base Metal          |
| 1HYW-6   | 140,000                                 | 132,300                              | 19.5                           | Base Metal          |
| Ave.     | 140,400                                 | 132,600                              | 19.17                          |                     |

TABLE 23. TENSILE PROPERTIES OF 1.00-INCH-THICK D6AC STEEL ALLOY BASE METAL (STRESS RELIEVED AFTER MACHINING)

| Specimen | Ultimate Tensile Strength, ksi | Yield Tensile Strength, ksi | Elongation In Two Inches, % |
|----------|--------------------------------|-----------------------------|-----------------------------|
| 1D6B-1   | 141,000                        | 112,400                     | 14.0                        |
| 1D6B-2   | 142,300                        | —                           | 13.5                        |
| 1D6B-3   | 143,600                        | 115,100                     | 13.0                        |
| Ave.     | 142,300                        | 113,750                     | 13.5                        |

TABLE 24. TENSILE PROPERTIES OF S5EB WELDED 1.00-INCH-THICK D6AC STEEL ALLOY PLATE (SQUARE BUTT JOINT, FLAT POSITION, PREHEATED TO 350°F BEFORE WELDING, STRESS RELIEVED AFTER MACHINING)

| Specimen | Ultimate Tensile Strength, ksi | Yield Tensile Strength, ksi | Elongation In Two Inches, % | Failure Location |
|----------|--------------------------------|-----------------------------|-----------------------------|------------------|
| 1D6W-1   | 141,900                        | 113,000                     | 13.0                        | Base Metal       |
| 1D6W-2   | 142,900                        | 113,800                     | 12.5                        | Base Metal       |
| 1D6W-3   | 142,600                        | 114,800                     | 13.5                        | Base Metal       |
| 1D6W-4   | 141,500                        | 113,800                     | 13.5                        | Base Metal       |
| 1D6W-5   | 142,400                        | 115,200                     | 13.5                        | Base Metal       |
| 1D6W-6   | 141,500                        | 114,400                     | 13.5                        | Base Metal       |
| Ave.     | 142,100                        | 114,200                     | 13.25                       |                  |

## SECTION IV

### PHASE III - PROCESS DEMONSTRATION

#### A. WORK AREAS

The purpose of this phase of the program was to demonstrate the capability of the SSEB equipment to weld a simulated structural component. An actual production article (the F-14 rear wing beam, Part No. A51B46574-1 and -2) was substituted for this component demonstration. SSEB Slot Welding techniques were developed for fixturing and vacuum sealing the part for the welding operation on a company funded program. Nondestructive inspection and mechanical testing were conducted on selected weldments to determine weld quality and strength of the welded part. Data generated in the course of this work was used to prepare an equipment specification (see Appendix I). To accomplish this work the following tasks, which furnished data applicable to current and future airframe application needs, were preformed:

- Component Selection and Planning
- F-14 Wing Beam Welding
- Inspection, Testing and Analysis of F-14 Wing Beam
- Specification Determination and In-House Demonstration

#### B. COMPONENT SELECTION AND PLANNING

To assure successful completion of this phase of the program, a production application was selected and evaluated in consultation with the Air Force. The Air Force selected this part in place of the proposed demonstration article, the tee weldment or the alternate long flat plate weldment. This part (F14 rear wing beam, Part No. A51B46574-1 and -2) was selected for several reasons. The first was to demonstrate SSEB welding capability to join a production article. The design, length, thickness and shape of this part made it an ideal candidate for SSEB welding. SSEB Slot Welding techniques for welding parts in a vacuum chamber/box were conceived during the course of previous in-house work concerned with F-14 improvements. This was done with the idea of making long-length weldments (extrusions, rib sections, flat plates etc.) inside a vacuum box, similiar in size to the Flat Plate Welding Fixture. Welding of wing beam material (Ti-6Al-6V-2Sn) could not be accomplished using the flat plate welding set up. Problems with the welding of titanium plate on the flat plate weld fixture had to be solved. The proposed program for SSEB welding of wing beams would solve the problems associated with flat-plate welding, i. e., welding of rib sections, GTA seal pass welding, part contamination, sliding-seal wear, and vacuum vapor problems associated with titanium plate welding.

The initial work required by this program was to design a welding fixture for production welding. Secondly, a vacuum box large enough to contain the fixture was designed for set up, and use in the SSEB facility. Concurrent with this design effort, a welding program was undertaken to develop slot welding techniques on the Preheat Steel Welding Fixture. Welding was conducted on Ti-6Al-6V-2Sn titanium alloy plate and short "L" extrusions to determine alloy weldability, weld bead characteristics,

weld alignment techniques, and to develop weld parametric data necessary for actual production welding of full-size wing beams. Following completion of this task, the vacuum box, which had been designed and fabricated, was set up in the SSEB welding facility. The set up of the vacuum box and welding tasks conducted, to verify welding concepts and the fabrication of five wing beams, is discussed below.

## C. F-14 WING BEAM WELDING

### 1. Selection and Description of Component Part

The outboard section of the rear wing beam (Part No. A51B46574-1 and -2) was selected for SSEB Slot Welding for several reasons. A company decision had been made to EB weld wing beams rather than machine large forgings. This is discussed in this section. Production EB welding capability was very limited at this time because of chamber availability and scheduling time. An alternative solution to the problem, therefore, was to develop a method for SSEB welding that would free the large EB chambers for production work and also be capable of handling the production workload. A company-funded Advanced Development Welding Program was undertaken to investigate SSEB capability. SSEB Slot Welding was evaluated on the Flat Plate and Preheat Steel Welding Fixtures. A vacuum chamber was fabricated to enclose wing beam weld fixtures in a restricted volume to shorten pump down time. The success of the nine-month program from June 1974 to March 1975 was completed by the welding of five F-14 wing beam sections and the mechanical testing of one wing beam.

The F-14 wing beam (Figure 62) was a Ti-6Al-6V-2Sn titanium alloy, nominally 0.300-inch-thick, 104-inch-long "U" channel which tapers from about 8 1/2 inches at the inboard end, to 4 1/2 inches at the outboard end. This beam had previously been machined from a 200 lb forging to an 18 to 20-pound finished part. By welding two machine-tapered extruded angles (GS 183B5-1PA and -2PA) together longitudinally, a built-up "U" channel could be produced which weighed only 40 to 50 pounds before final machining. Consequently, both the material fly-to-buy ratio and the machining time could be reduced substantially by welding.

### 2. Welding Program

The original design for the Preheat Steel Fixture was to make a weld through a cover sheet and simultaneously weld the workpiece fixture below the cover sheet. The design concept was changed after the Slot Welding Concept was successfully demonstrated and a new slotted aluminum cover plate fabricated to replace the original cover plate. Ti-6Al-6V-2Sn plate material and short extruded angles were prepared for welding evaluation. Welding parameters were developed on 0.300 inch-thick, Ti-6Al-6V-2Sn Titanium alloy plate material as shown in Table 25 (twelve bead-on-plate (B.O.P.) and four butt welds). The best set of parameters were 30 KV beam voltage, 150 MA beam current, 6.20 amperes focus current, and 30 inches per minute travel speed.

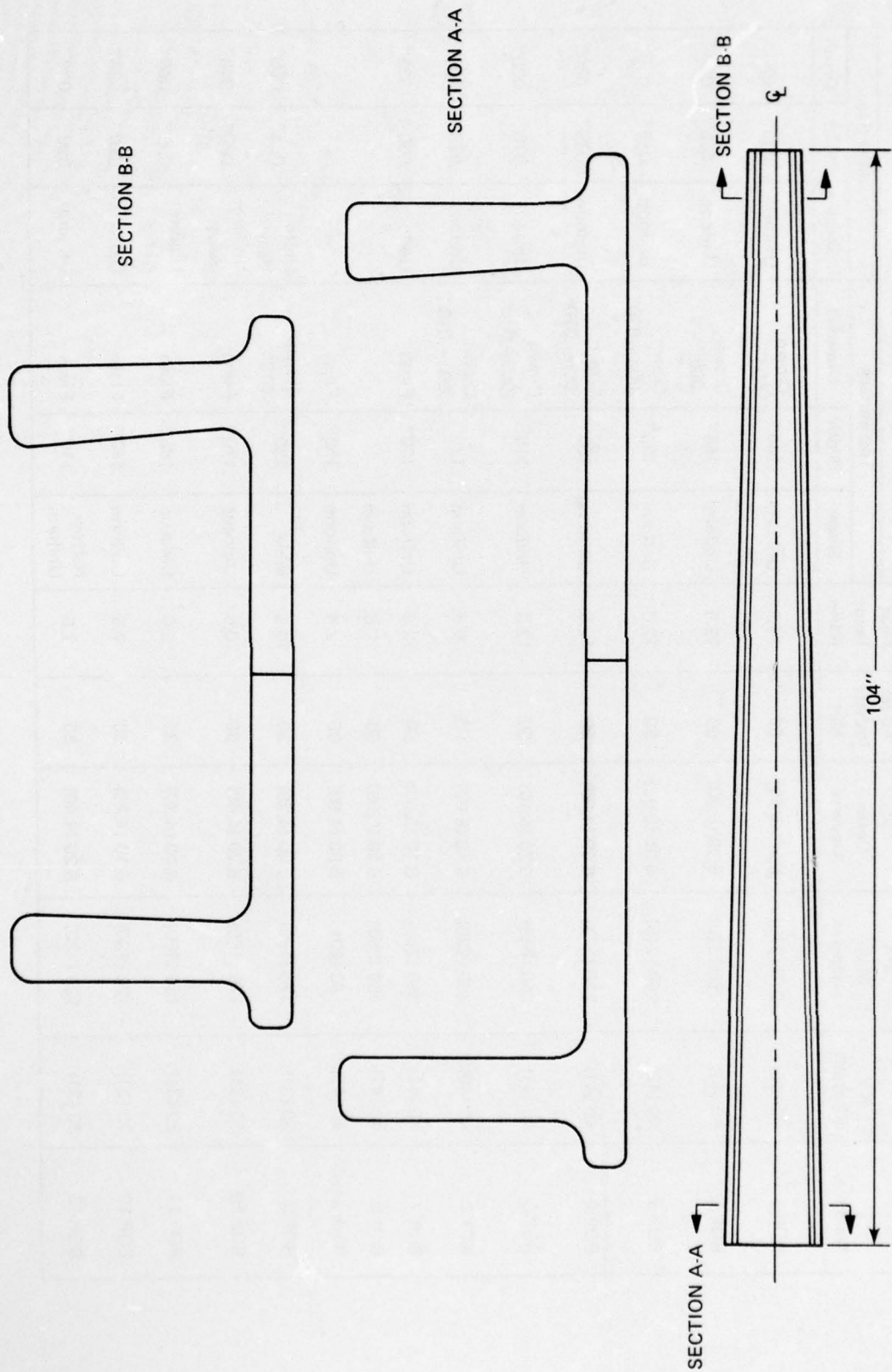

Figure 62 F-14 Wing Beam Sections

TABLE 25. 0.300-INCH THICK Ti-6Al-6V-2Sn TITANIUM ALLOY PLATE WELD SERIES

| Weld No.              | KV<br>Kilovolts | MA<br>Milli-<br>Amperes | Focus<br>Current<br>Amperes | Travel<br>Inches/<br>Min. | Heat<br>Input<br>KJ/In. | Results           |       |                     |                  |       |       |
|-----------------------|-----------------|-------------------------|-----------------------------|---------------------------|-------------------------|-------------------|-------|---------------------|------------------|-------|-------|
|                       |                 |                         |                             |                           |                         | Top Surface       |       |                     | Under Bead       |       |       |
|                       |                 |                         |                             |                           |                         | Shape             | Width | Underfill           | Shape            | Width | Depth |
| BOP 1                 | 45 (46)         | 270 (270)               | 6.10 (5.40)                 | 50                        | 14.5                    | Uniform           | .140" | Crown<br>.008"      | Uniform          | .065" | .030" |
| BOP 2                 | 40 (41)         | 250 (220)               | 6.10 (5.00)                 | 50                        | 12.0                    | Uniform           | .155" | Crown<br>.008"      | Uniform          | .065" | .030" |
| BOP 3                 | 40 (42)         | 250 (245)               | 6.05 (5.00)                 | 50                        | 12.0                    | Uniform           | .155" | Crown<br>.005-.010" | Uniform          | .065" | .030" |
| BOP 4                 | 40 (41)         | 250 (245)               | 6.00 (4.90)                 | 50                        | 12.0                    | Uniform           | .155" | Crown<br>.005-.010" | Uniform          | .085" | .030" |
| BOP 5                 | 40 (41)         | 250 (245)               | 6.20 (5.10)                 | 50                        | 12.0                    | Uniform           | .115" | Crown<br>.005-.010" | Uniform          | .070" | .030" |
| BOP 6                 | 40 (40)         | 200 (180)               | 6.10 (5.00)                 | 50                        | 9.6                     | Uniform           | .125" | Crown<br>.005-.010" | Uniform          | .065" | .030" |
| Butt 7                | 40 (41)         | 250 (250)               | 6.10 (5.00)                 | 50                        | 12.0                    | Uniform           | .120" | Flush               | Uniform          | .060" | .025" |
| Butt 8<br>(lock pass) | 40 (41)         | 250 (250)               | 6.20 (5.05)                 | 50                        | 12.0                    | Uniform           | .150" | Flush               | Uniform          | —     | —     |
| BOP 9                 | 30 (31)         | 175 (180)               | 5.90 (4.80)                 | 30                        | 2.4                     | Wide              | .230" | Crown<br>.010"      | Uniform<br>Heavy | .095" | .050" |
| BOP 10                | 30 (31)         | 175 (180)               | 6.20 (4.40)                 | 30                        | 10.5                    | Defocus           | .170" | Flush               | Uniform<br>Heavy | .090" | .045" |
| BOP 11                | 30 (31)         | 150 (160)               | 6.20 (4.30)                 | 30                        | 9.0                     | Defocus           | .165" | Flush               | Uniform<br>Heavy | .085" | .040" |
| BOP 12                | 30 (31)         | 125 (130)               | 6.10 (4.25)                 | 30                        | 7.5                     | Uniform           | .140" | Flush               | Uniform          | .060" | .035" |
| BOP 13                | 30 (31)         | 125 (130)               | 6.20 (4.40)                 | 30                        | 7.5                     | Narrow<br>Uniform | .110" | Flush               | Uniform          | .050" | .030" |

TABLE 25. 0.300-INCH-THICK Ti-61-6V-2Sn TITANIUM ALLOY PLATE WELD SERIES (CONT)

| Weld No.               | KV<br>Kilovolts | MA<br>Milli-<br>Amperes | Focus<br>Current<br>Amperes | Travel<br>Inches/<br>Min. | Heat<br>Input<br>KJ/in. | Results     |               |                |            |       |       |
|------------------------|-----------------|-------------------------|-----------------------------|---------------------------|-------------------------|-------------|---------------|----------------|------------|-------|-------|
|                        |                 |                         |                             |                           |                         | Top Surface |               |                | Under Bead |       |       |
|                        |                 |                         |                             |                           |                         | Shape       | Width         | Underfill      | Shape      | Width | Depth |
| BOP 14                 | 30 (31)         | 150 (160)               | 6.20 (4.20)                 | 30                        | 9.0                     | Uniform     | .150"         | Crown<br>.005" | Uniform    | .075" | .035" |
| Butt 15<br>(lock pass) | 30 (31)         | 150 (160)               | 6.20 (4.40)                 | 30                        | 9.0                     | —           | Plates Opened | —              | —          | —     | —     |
| Butt 16<br>(lock pass) | 40              | 25                      | 5.90                        | 50                        | 1.2                     | Uniform     | .140"         | Flush          | Uniform    | .090" | .040" |
|                        | 30 (31)         | 150 (160)               | 6.20 (4.40)                 | 30                        | 9.0                     | Uniform     | .150"         | Flush          | Uniform    | —     | —     |
|                        | 40              | 50 (50)                 | 5.90 (4.80)                 | 50                        | 2.4                     | Uniform     | .150"         | Flush          | Uniform    | —     | —     |

These parameters produced a clean, uniform, flush weld, 0.140-inch wide on the crown and 0.090 inch wide on the root side. The optimum set of parameters developed for 0.300-inch-thick plate were used as the basis for parameter development on 0.300-inch-thick Ti-6Al-6V-2Sn extruded material.

A total of five butt welds were made using the slot welding techniques in the Steel Preheat Chamber. Optimum parameters for the extrusions were 30 kv beam voltage, 175 ma beam current, 6.40 amperes focus current and 30 inches per minute travel speed. The parameters evaluated are given in Table 26.

### 3. Fixture and Vacuum/Box Design

Two production welding fixtures were designed and fabricated for EB Welding. These fixtures were provided for use on F-14 production items. Considerations in design of the fixtures were made for use of these fixtures on the SSEB welding set up where they would be used in conjunction with a narrow, low profile vacuum chamber. An aluminum vacuum chamber was designed with inside dimensions of 123-inch length, 16-inch width, and 7.5-inch height so that the wing beam fixtures could be set up and aligned inside the box and provide ample clearance for loading and unloading extrusions in the box dimensions. Centering of the fixture inside the vacuum box was accomplished by using centering pins to align the fixture in the center of the box (Figures 63 and 64). The cover plate was also aligned on the top flange of the box and bolted in place on an "O" ring seal. Provisions on the welding fixture were made for vertical clamping of the extrusions and for lateral pressure to be applied perpendicularly to the weld seam.

TABLE 26. 0.300-INCH-THICK Ti-6Al-6V-2Sn TITANIUM ALLOY EXTRUSION WELD SERIES

| Weld No.              | KV<br>Kilovolts | MA<br>Milli-<br>Amperes | Focus<br>Current<br>Amperes | Travel<br>Inches/<br>Min. | Heat<br>Input<br>KJ/In. | Results     |       |           |            |       |       |
|-----------------------|-----------------|-------------------------|-----------------------------|---------------------------|-------------------------|-------------|-------|-----------|------------|-------|-------|
|                       |                 |                         |                             |                           |                         | Top Surface |       |           | Under Bead |       |       |
|                       |                 |                         |                             |                           |                         | Shape       | Width | Underfill | Shape      | Width | Depth |
| Butt 1                | 30              | 150                     | 6.20                        | 30                        | 9.0                     | Uniform     | .115" | Flush     | Uniform    | .065" | .035" |
| Butt 2<br>(lock pass) | 30              | 150                     | 6.20                        | 30                        | 9.0                     | Uniform     | .120" | Flush     | Uniform    | .070" | .035" |
| Butt 3<br>(lock pass) | 30              | 50                      | 6.20                        | 30                        | 3.0                     | Uniform     | —     | Flush     | Uniform    | .070" | .035" |
| Butt 3<br>(lock pass) | 30              | 150                     | 6.20                        | 30                        | 9.0                     | Uniform     | .120" | Flush     | Uniform    | .075" | .035" |
| Butt 4<br>(lock pass) | 50              | 30                      | 6.20                        | 30                        | 3.0                     | Uniform     | —     | —         | —          | —     | —     |
| Butt 4<br>(lock pass) | 30              | 175                     | 6.40                        | 50                        | 10.5                    | Uniform     | .150" | Flush     | Uniform    | .100" | .035" |
| Butt 5<br>(lock pass) | 30              | 50                      | 6.30                        | 30                        | 3.0                     | Uniform     | —     | —         | —          | —     | —     |
| Butt 5<br>(lock pass) | 30              | 175                     | 6.40                        | 30                        | 10.5                    | Uniform     | .145" | Flush     | Uniform    | .100" | .040" |
| Butt 5<br>(lock pass) | 30              | 50                      | 6.30                        | 30                        | 3.0                     | Uniform     | —     | —         | —          | —     | —     |

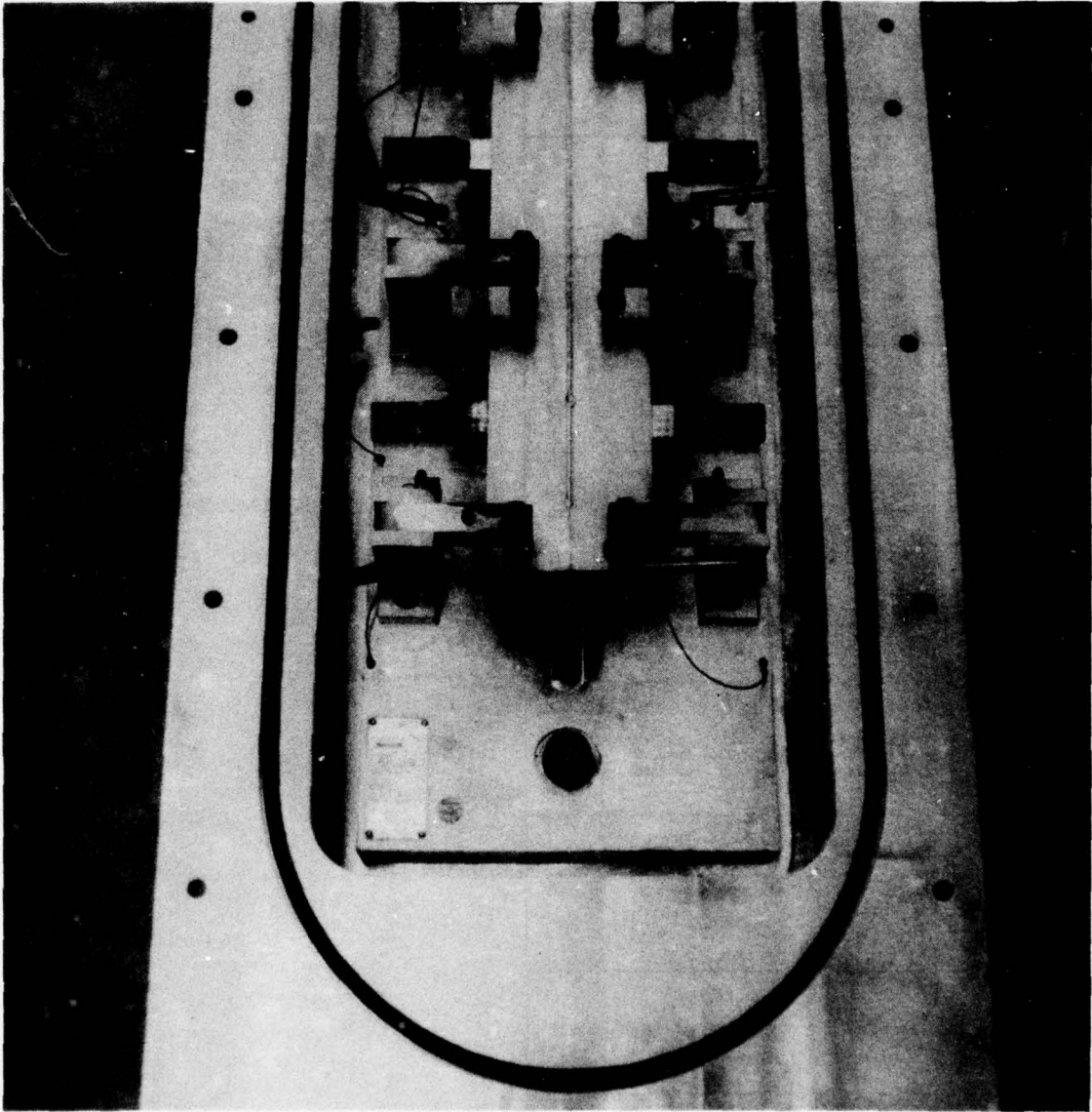

Figure 63 Fixture Alignment in Vacuum Box

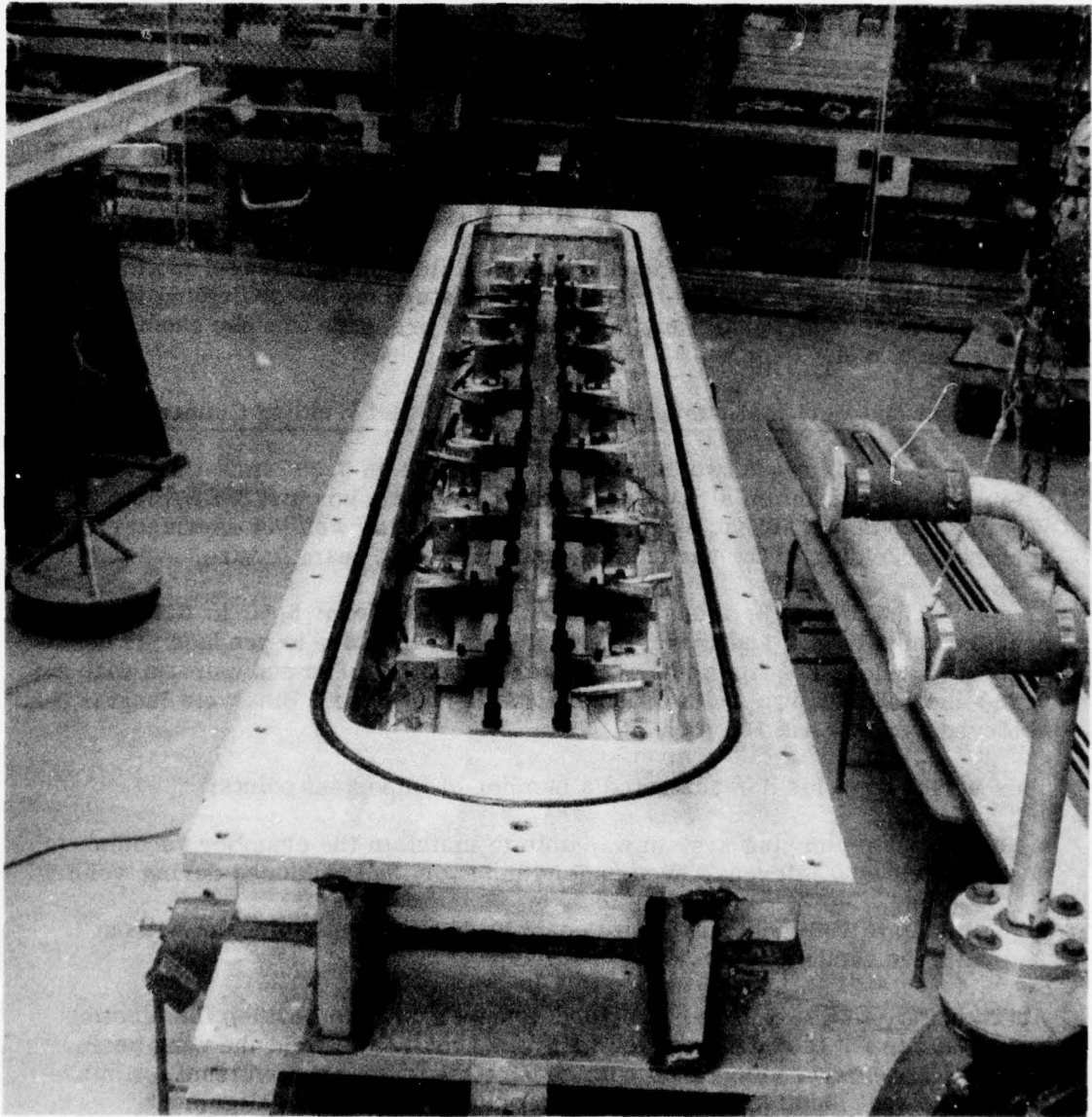

Figure 64 Vacuum Box with Wing Beam Fixture

#### 4. Set Up of Vacuum Box in SSEB Welding Facility (Figure 65)

The vacuum box for the Wing Beam Welding demonstration was designed to use the table set up that was used on the Flat-Plate Welding Fixture. The dual and single roundways and gear rack were removed from the Flat-Plate Welding Fixture and adapted to the aluminum vacuum box. The box was then set up on the table/rails and fully assembled with "O" rings, cover plate and seal plate. A 100-CFM vacuum pump (later replaced by a more efficient duo-seal 53-CFM vacuum pump) was connected to the seal plate vacuum lines and checked for vacuum sealing. The vacuum pump was capable of attaining a 10-15 micron-level in several minutes. A rigid support was then pinned to the weld table and bolted to the seal plate to prevent movement of the seal plate when driving the vacuum box under it. Tests were then performed to determine and calibrate travel speeds of the vacuum box prior to conducting welding studies. Travel speeds as low as 30 IPM were possible with this setup. The increase in the frictional-drag force (seal plate on "O" ring seal) required additional force to drive system thereby providing uniform travel motion at slower IPM settings. On the flat plate weld fixture the lower driving force did not keep the gear and gear rack under constant pressure thereby causing chatter during the travel.

#### 5. Check-Out and Verification of Large Scale SSEB Slot Welding Concept.

Eight bead-on-plate and two butt welds were made on 0.300 inch-thick Ti-6Al-6V-2Sn titanium alloy plate using the vacuum box and SSEB/Slot Welding technique. These welds were made to refine welding parameter for wing beam welding in the vacuum box using the wing beam fixture.

As shown in Table 27, focus current was varied from 5.85 to 6.20 amperes at 30 kv and 150 ma, and travel speed of 30 ipm in order to produce the best appearing weld. The final butt welds were smooth, clean and uniform with a 0.200-inch wide crown and a 0.080-inch wide root bead. Butt weld lengths achieved were 98 and 105 inches.

This series of welds demonstrated a number of important points:

- The vacuum pumping system was able to maintain the chamber vacuum level below 60 microns, even under the vapor load produced during welding.
- Welds up to 105 inches in length could be made with the system without losing the vacuum seal.

Additionally, this test series provided an opportunity to develop the election beam, alignment techniques which would be required to weld the wing beam. Spot check welds were made on both ends of the test plates. Visual examination of the spot locations was made to determine weld beam alignment. Changes were made by moving the seal plate/SSEB head to correct the alignment condition. Tolerances could be held to within .010-0.015-inches of the weld seam.

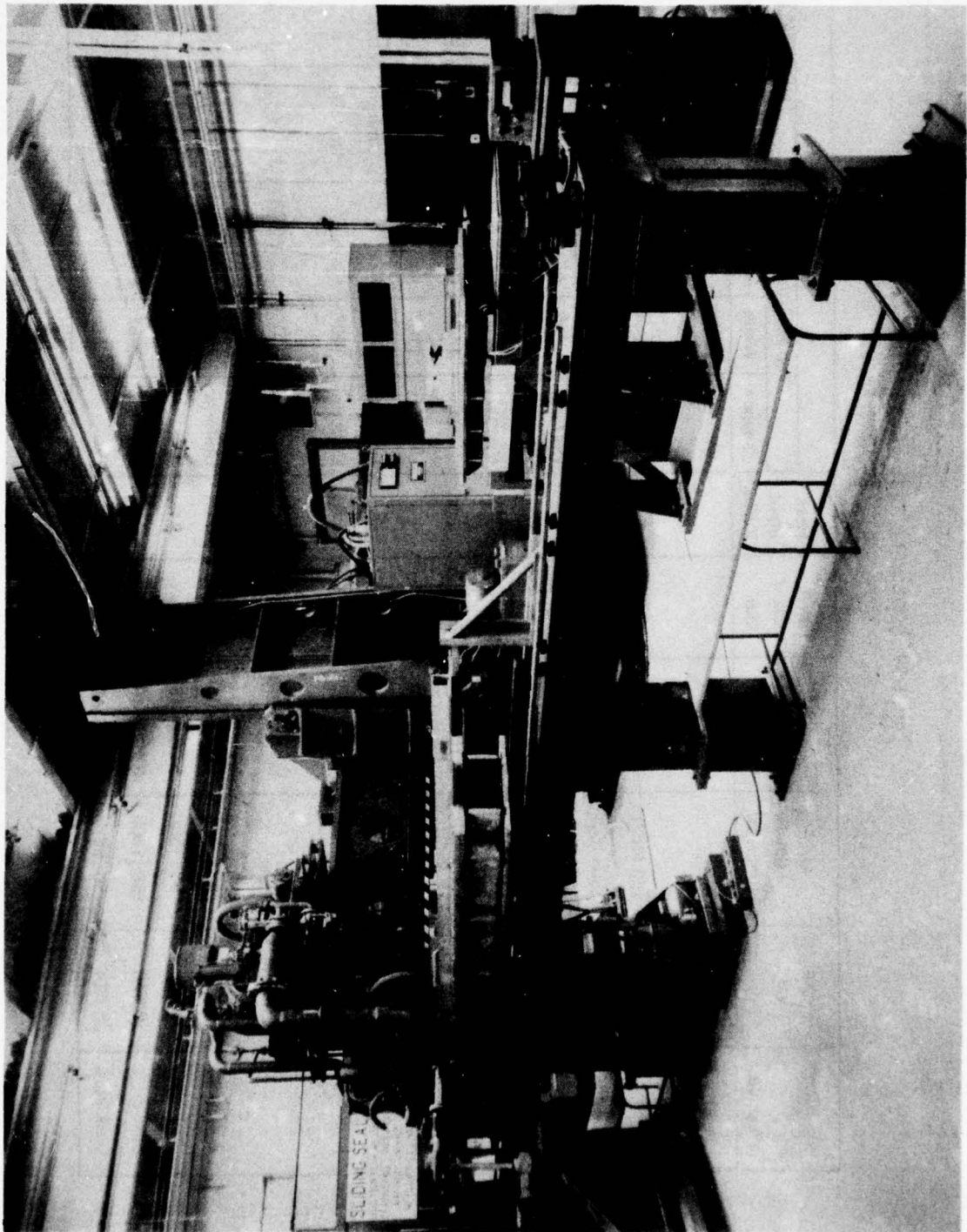

Figure 65 SSEB/Slot Weld Set Up - Vacuum Box

TABLE 27. SLOT WELD TEST WELD SERIES

| Weld No.              | KV<br>Kilovolts        | MA<br>Milli-<br>Amperes | Focus<br>Current<br>Amperes | Travel<br>Inches/<br>Min. | Heat<br>Input<br>KJ/In. | Results           |       |           |            |       |       |  |
|-----------------------|------------------------|-------------------------|-----------------------------|---------------------------|-------------------------|-------------------|-------|-----------|------------|-------|-------|--|
|                       |                        |                         |                             |                           |                         | Top Surface       |       |           | Under Bead |       |       |  |
|                       |                        |                         |                             |                           |                         | Shape             | Width | Underfill | Shape      | Width | Depth |  |
|                       | 0.300" Ti-6-6-2 Plate: |                         |                             |                           |                         |                   |       |           |            |       |       |  |
| BOP 1                 | 30 (30)                | 150 (150)               | 5.85 (4.20)                 | 30                        | 9.0                     | Wide<br>Uniform   | .233" | Underfill | Uniform    | .050" | —     |  |
| BOP 2                 | 30 (30)                | 150 (150)               | 5.90 (4.25)                 | 30                        | 9.0                     | Uniform           | .195  | Flush     | Uniform    | .060" | .065" |  |
| BOP 3                 | 30 (30)                | 150 (150)               | 6.00 (4.30)                 | 30                        | 9.0                     | Uniform           | .130" | Flush     | Uniform    | .060" | .035" |  |
| BOP 4                 | 30 (30)                | 150 (150)               | 6.05 (4.35)                 | 30                        | 9.0                     | Uniform<br>Narrow | .125" | Flush     | Uniform    | .065" | .030" |  |
| BOP 5                 | 30 (30)                | 150 (150)               | 6.10 (4.40)                 | 30                        | 9.0                     | Uniform           | .145" | Flush     | Uniform    | .065" | .035" |  |
| BOP 6                 | 30 (30)                | 150 (150)               | 6.15 (4.45)                 | 30                        | 9.0                     | Uniform           | .170" | Flush     | Uniform    | .020" | .035" |  |
| BOP 7                 | 30 (30)                | 150 (150)               | 6.20 (4.45)                 | 30                        | 9.0                     | Uniform           | .175" | Flush     | Uniform    | .075" | .050" |  |
| BOP 8                 | 30 (30)                | 150 (150)               | 5.95 (4.30)                 | 30                        | 9.0                     | Uniform           | .140" | Flush     | Uniform    | —     | —     |  |
|                       | 0.300" Ti-6-6-2 Plate: |                         |                             |                           |                         |                   |       |           |            |       |       |  |
| Butt 1<br>(lock pass) | 30 (30)                | 150 (150)               | 6.20 (4.45)                 | 30                        | 9.0                     | Uniform           | .200" | Flush     | Uniform    | .080" | .060" |  |
|                       | 30 (30)                | 50 (150)                | 5.20 (4.45)                 | 30                        | 3.0                     | —                 | —     | —         | —          | —     | —     |  |
| Butt 2<br>(lock pass) | 30 (30)                | 150 (150)               | 6.20 (4.45)                 | 30                        | 9.0                     | Uniform           | .200" | Flush     | Uniform    | .080" | .060" |  |
|                       | 30 (30)                | 50 (66)                 | 6.20 (4.45)                 | 30                        | 3.0                     | —                 | —     | —         | —          | —     | —     |  |

## 6. Test Welding of F-14 Wing Beams

Five wing beams were SSEB welded using the slot-welding technique. The first four beams were welded using a partial penetration locking pass at 30 kv beam voltage, 50 ma beam current, 6.20 amps focus current and 30 ipm travel speed followed by a full penetration pass at 30 kv beam voltage, 150 ma beam current 6.20 amps focus current and 30 ipm travel speed. The fifth beam was welded without the partial penetration locking pass.

All extrusions were machined along one leg to produce a tapered channel. Witness lines were scribed adjacent to the joint faying surfaces to permit weld alignment inspection. The beams were acid-cleaned immediately (not more than four hours) before welding per GSS 7020D. The taper-machined and cleaned beams were loaded into the welding fixture which was then loaded into the movable vacuum chamber. Once the fixture was pinned in place, the slotted top cover was bolted on, the rubber O-rings were cleaned and lubricated, and the seal plate was put in position. The system was evacuated and weld alignment was performed by spotting the electron beam onto the wing beam joint, as previously described.

No problems were encountered in welding the first four beams. All welds were made at an initial chamber vacuum level of 5 to 15 microns. During welding the vacuum level rose to 35 to 55 microns in the vacuum chamber. The resulting welds were uniform and fairly clean. Table 28 describes the resulting beads. All beams were X-rayed per GSS6205C and were generally found to contain scattered and isolated linear porosity with occasional large pores (up to 0.030 inch diameter). This weld porosity, was attributed to the heavy mill scale present on the as-extruded angles. Although the scale was removed in cleaning, oxygen contamination apparently extended below the outer surface.

In an effort to reduce the porosity produced in the welded beams, the fifth beam was welded without a partial penetration locking pass. Although a scratch on the bottom surface of the sealing plate caused a loss of vacuum approximately half way along the weld, the system was re-evaluated and the weld was continued without difficulty. Radiographs of the fifth beam revealed that porosity had indeed been reduced by eliminating the locking pass, and, further, no defects were associated with the interruption and restart of the weld. Detailed mechanical property studies, discussed in the next section, revealed there were no adverse effects on weld properties due to the loss of vacuum during welding.

A photograph of the welded wing beams is shown in Figure 66.

### D. NDI AND MECHANICAL TESTING OF F-14 WING BEAM

Nondestructive inspections of each wing beam weld was made for all five weldments. This consisted of visual and witness line inspection to insure weld beam centering on weld seam, and to measure weld bead characteristics. Radiographic inspections of each weldment were made to determine amount and size of internal voids, porosity inclusions and missed seams. Two weldments were subsequently machined 0.030 inch on top and bottom surface and re-examined by radiographic and ultrasonic methods.

TABLE 28. WING BEAM WELDING

| Weld No.            | KV<br>Kilovolts | MA<br>Milli-<br>Amperes | Focus<br>Current<br>Amperes | Travel<br>Inches/<br>Min. | Heat<br>Input<br>KJ/In. | Results     |       |       |           |       |       |            |       |       |
|---------------------|-----------------|-------------------------|-----------------------------|---------------------------|-------------------------|-------------|-------|-------|-----------|-------|-------|------------|-------|-------|
|                     |                 |                         |                             |                           |                         | Top Surface |       |       | Underfill |       |       | Under Bead |       |       |
|                     |                 |                         |                             |                           |                         | Shape       | Width | Depth | Shape     | Width | Depth | Shape      | Width | Depth |
| WB 1<br>(lock pass) | 30 (30)         | 150 (150)               | 6.20 (4.45)                 | 30                        | 9.0                     | Uniform     | .200" | Flush | Uniform   | .060" | .050" |            |       |       |
| WB 2<br>(lock pass) | 30 (30)         | 50 (60)                 | 6.20 (4.45)                 | 30                        | 3.0                     | —           | —     | —     | —         | —     | —     |            |       |       |
| WB 3<br>(lock pass) | 30 (30)         | 150 (150)               | 6.20 (4.45)                 | 30                        | 9.0                     | Uniform     | .200" | Flush | Uniform   | .070" | .060" |            |       |       |
| WB 4<br>(lock pass) | 30 (30)         | 50 (60)                 | 6.20 (4.45)                 | 30                        | 3.0                     | —           | —     | —     | —         | —     | —     |            |       |       |
| WB 5<br>(lock pass) | 30 (30)         | 150 (150)               | 6.20 (4.45)                 | 30                        | 9.0                     | Uniform     | .175" | Flush | Uniform   | .075" | .045" |            |       |       |
|                     |                 |                         |                             |                           |                         | —           | —     | —     | —         | —     | —     |            |       |       |
|                     |                 |                         |                             |                           |                         | Uniform     | .175" | Flush | Uniform   | .070" | .060" |            |       |       |
|                     |                 |                         |                             |                           |                         | —           | —     | —     | —         | —     | —     |            |       |       |
|                     |                 |                         |                             |                           |                         | Uniform     | .160" | Flush | Uniform   | .055" | .045" |            |       |       |

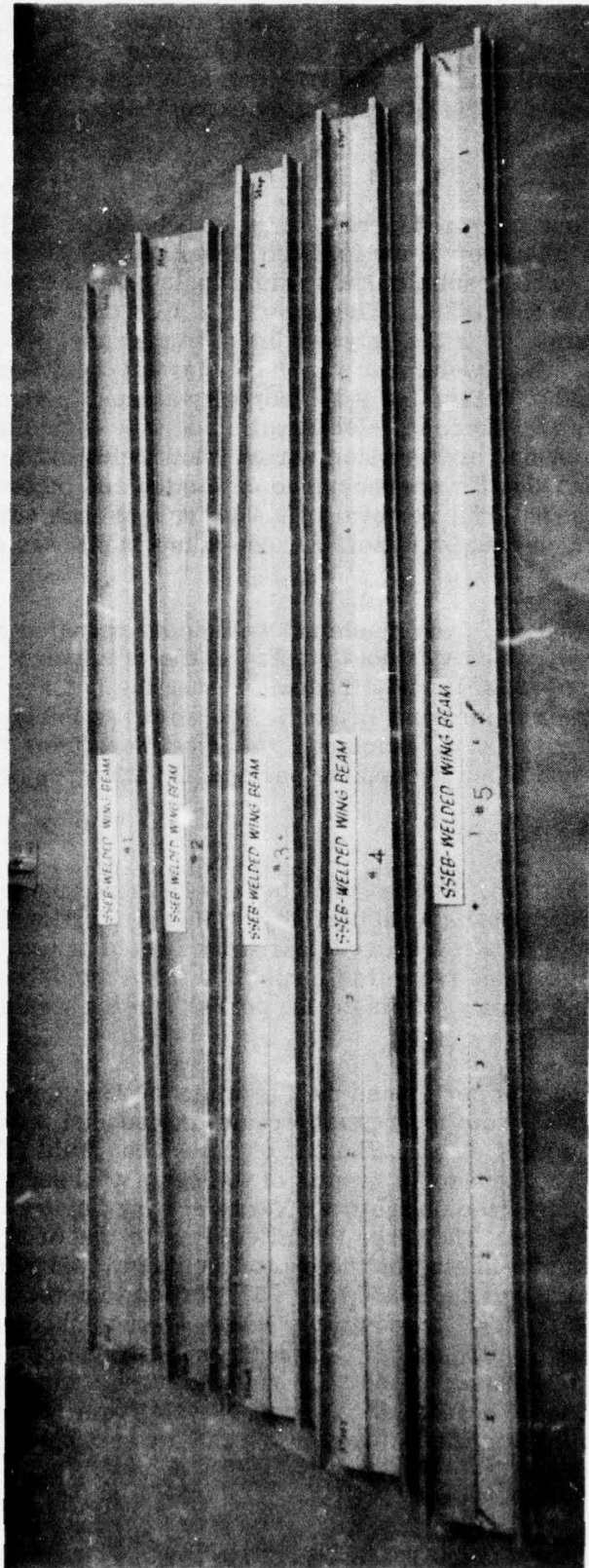

Figure 66 Welded F-14 Wing Beams

To assist in the evaluation of the SSEB welding process; tensile, fatigue and fracture toughness tests were conducted on selected weldments. These tests were conducted to determine the tensile, fatigue and fracture toughness properties of base metal and SSEB welded Ti-6Al-6V-2Sn titanium alloy extrusions.

#### 1. Radiographic Inspection

All welded wing beams were radiographically inspected per GSS6205 C and were found to contain scattered and isolated linear porosity when two weld passes were used. The results of the radiographic examination and film numbers are listed in Table 29. Wing Beam No. 5, which was welded in a single-pass operation, was the only weldment to successfully pass radiographic inspection. Each weldment was marked every twelve inches along the length of the weld to determine if the porosity amount and sizes were common in each beam. No conclusive results could be formulated, since the porosity levels, amounts, and location varied from weldment to weldment. Weldments No. 2 and No. 3 were machined on the top and bottom surfaces of the weld area with a material removal of 0.030 inch on each surface. Apparently, the oxygen contamination in these components was deeper than anticipated.

Radiographic examination of the machined weldments revealed more linear porosity in the welds, which was not detected in the previous X-rays. The weldments were also subjected to ultrasonic inspection. Since all welded test specimens were taken from Wing Beam No. 5, which satisfactorily passed radiographic requirements, all machined test specimens from the weld area were radiographed and found acceptable per specification requirements.

#### 2. Ultrasonic Inspection

Wing Beams No. 2 and No. 3 were subjected to ultrasonic inspection to determine the size and depth of the weld porosity. This inspection discovered a wide and heavy band of scattered linear porosity located at varying depths in the welds. It was concluded from this inspection that further machining of the wing beams would not totally eliminate the porosity in the welds No. 2 and No. 3.

Ultrasonic inspection was performed on 3 sections of wing beam No. 5. These sections were removed from the restart area of the second weld (#1), the middle of the second weld (#2) and the end of the second weld (#3). Figures 67, 68 and 69 show the ultrasonic results of the seam of these sections. Porosity that was undetected on the first X-ray of wing beam #5 was detected by ultrasonic inspection. The large visual void at the end of section (#3) was the void caused by the weld stop on the end of the beam. A radiographic inspection of the machined sections (EBF #321) failed to detect this porosity since it is below the equipment sensitivity level (1% of thickness) and radiographic specification requirements. For materials which are .300-inch-thick, the minimum level of porosity detectable by radiographic inspection is approximately .003 to .005 inches. Porosity levels from .001 to .003 inches were later found to initiate the failures in the fatigue test specimens.

TABLE 29. RADIOGRAPHIC RESULTS OF SSEB/SLOT WELDED Ti-6Al-4V-2Sn  
TITANIUM ALLOY WING BEAMS

| Wing Beam No. | EB Film No. | Results - Indicated Per 12 Inch Sections |  |                         |   |                                       |                         |                 |                                 |
|---------------|-------------|--|--|-------------------------|---|---------------------------------------|-------------------------|-----------------|---------------------------------|
|               |             | 1 Ft.                                    | 2 Ft.                                  | 3 Ft.                   | 4 Ft.                                       | 5 Ft.                                 | 6 Ft.                   | 7 Ft.           | 8 Ft.                           |
| Wing Beam # 1 | EBF # 209   | -  | -                                      | Fine Scattered Porosity | Fine Scattered Porosity                     | Scattered Porosity<br>1 Pore<br>.030" | Fine Scattered Porosity | 1 Pore<br>.010" | -                               |
| Wing Beam # 2 | EBF # 209   | -  | -                                      | 1 Pore<br>.010"         | 1 Pore<br>.010                              | (Fine Scattered Porosity)             | -                       | -               | Mis seam                        |
| Wing Beam # 3 | EBF # 214   | 1 Pore<br>.015"                          | -                                      | 1 Pore<br>.025"         | -   | 1 Pore<br>.025"                       | 5 Pores<br>(.010-.025") | -               | -                               |
| Wing Beam # 4 | EBF # 214   | 2 Pores<br>.010"-.025"                   | -                                      | -                       | -   | 2 Pores<br>.015"-.015"                | -                       | -               | 3 Pores<br>.015"-.025"<br>.025" |
| Wing Beam # 5 | EBF # 216   | -  | -                                      | -                       | -   | -                                     | -                       | -               | -                               |
| Wing Beam # 2 | EBF # 220   | -  | (Scattered Linear Porosity Throughout) |                         | -   | -                                     | -                       | -               | -                               |
| Wing Beam # 3 | EBF # 220   | 1 Pore<br>.020"                          | 1 Pore<br>.025"                        | 1 Pore<br>.025"         | (Fine Scattered Linear Porosity Throughout) |                                       | -                       | -               | -                               |

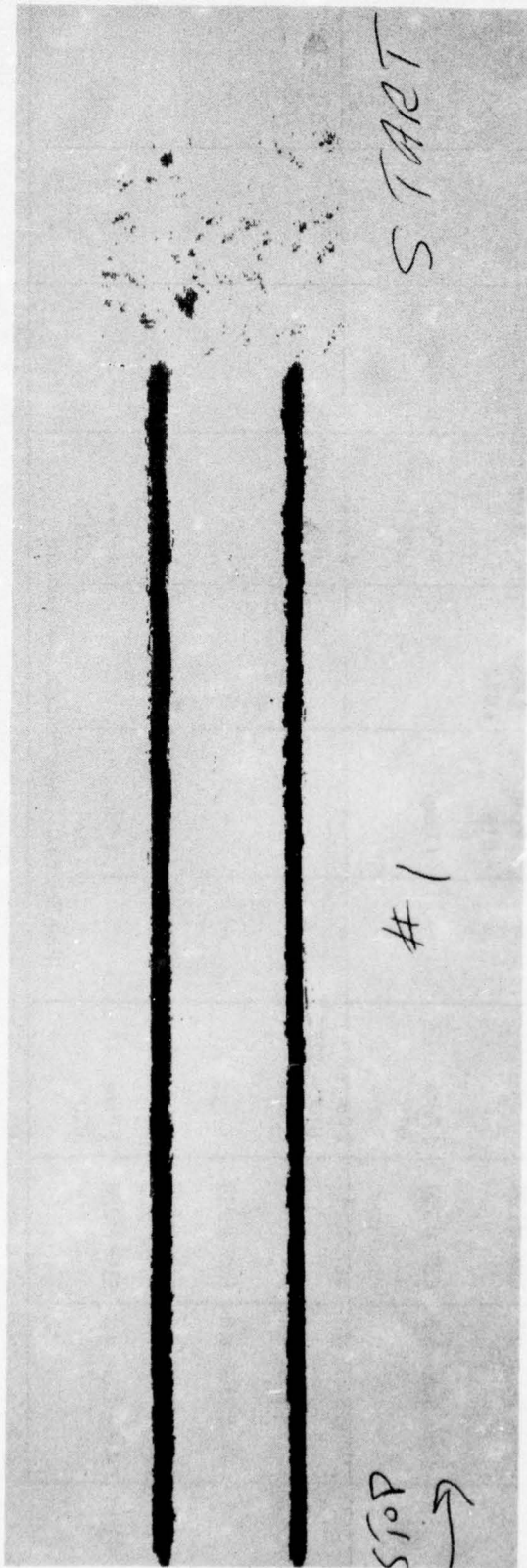

Figure 67 Ultrasonic Inspection Section No. 1

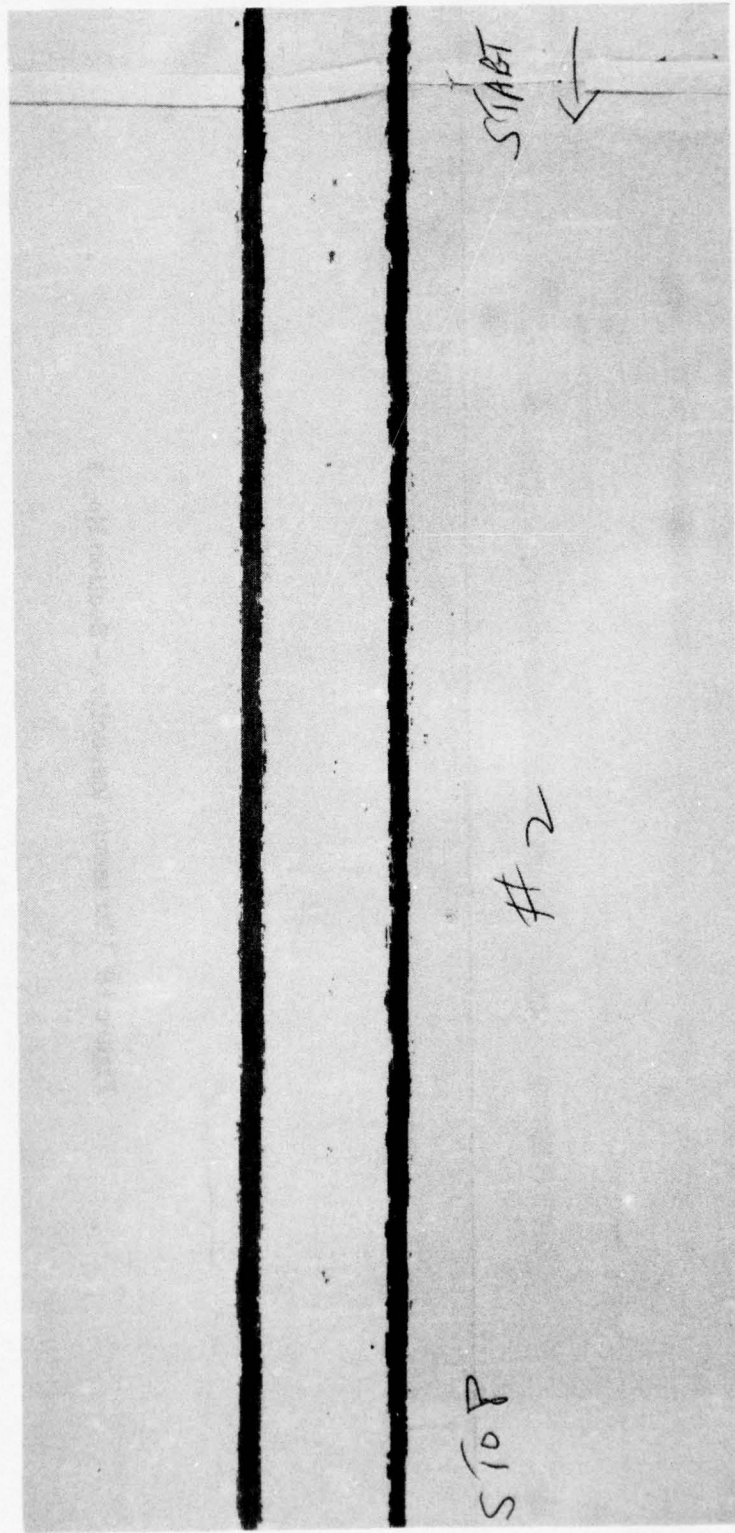

Figure 68 Ultrasonic Inspection - Section No. 2

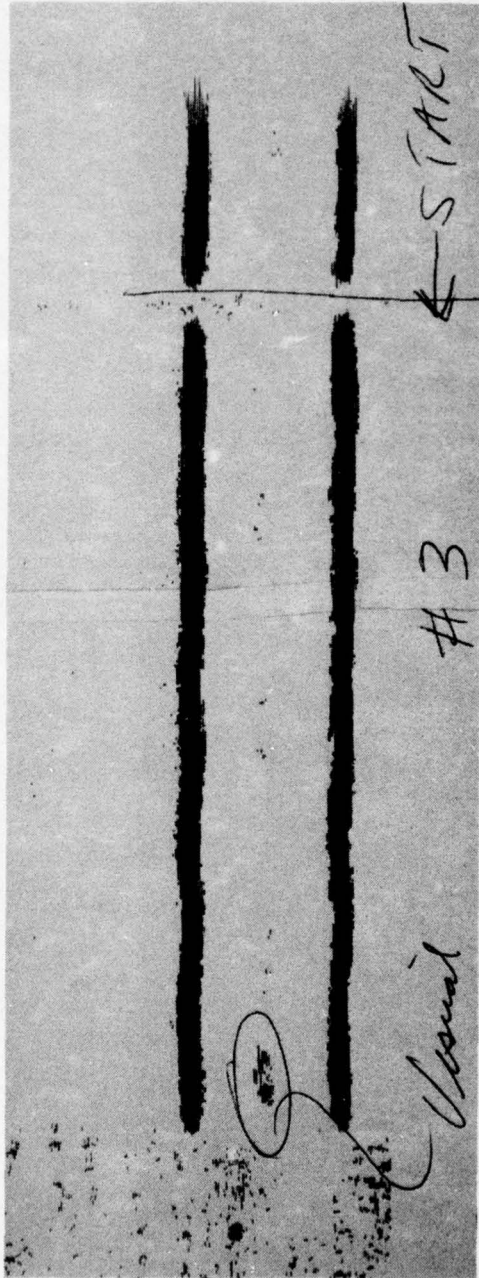

Figure 69 Ultrasonic Inspection - Section No. 3

### 3. Determination of Room Temperature Mechanical Properties

a. Layout of Test Specimen Location on Wing Beam - Tensile, fracture toughness and fatigue properties were measured for both the base metal and welded areas of the Ti-6Al-6V-2Sn extruded wing beams. Test specimens were removed from Wing Beam No. 5 as shown in Figure 70. Prior to testing, the specimens were stress-relieved at 1300°F for 2 hours and furnace cooled (50°F/half hr) to 800°F.

#### b. Test Specimen Configurations and Test Data

- (1) Tension - Static tension specimens were individually installed in a universal testing machine and subjected to an axial tensile load applied at a constant strain rate of 0.005 in/in/min (to yield) until failure occurred. Of the nine axial tensile specimens, three were base metal controls, machined in accordance with Grumman Engineering Department Provision 45 MPS241, (Figure 71). Three specimens containing a centrally located transverse weld were machined in accordance with Grumman Engineering Department Provision TGS 5350 (Figure 72). The remaining three specimens were machined in accordance with Grumman Engineering Department drawing TGS 5359 and contained a centrally located longitudinal weld (Figure 73).

The observed average base metal tensile properties of 161.3 ksi ultimate strength, 148.3 ksi yield strength, and 13.0 percent elongation compare well with typical tensile properties for plate material. Transverse weld tensile values were 161.6 ksi ultimate strength, 146.8 ksi yield strength, and 9.3 percent elongation. These values represent almost 100% joint tensile efficiency and excellent weld ductility. Longitudinal tensile specimens were tested from three locations, as shown in Figure 58. Locations No. 1 and No. 3 are in uninterrupted areas while location No. 2 is in the area where the vacuum was lost and the weld restarted. The fact that the tensile properties of all three areas are essentially the same suggests that these were no adverse effects on the weld properties when the sliding vacuum seal was lost, and the weld was interrupted. Visual examination of the transverse tensile specimens showed that all three specimens failed in the base metal. Figures 74 and 75 show representative samples of the test specimens and close-up view of the failure location. All test data for tensile testing are listed in Tables 30 and 31.

- (2) Fracture Toughness - The specimens were tested in accordance with ASTM method E399-70T utilizing a fatigue machine for crack propagation and a universal testing machine for tension testing. The six fracture toughness coupons were machined in accordance with Grumman Engineering Department Provision TGS 1094. Three specimens contained a transverse weld as shown in Figure 76.

Fracture toughness was measured in both the base metal and in the weld metal using a compact tension specimen. In the welded specimen the notch was oriented along, and in, the weld fusion zone. The measured average values of 45.4 ksi in. in the base metal and

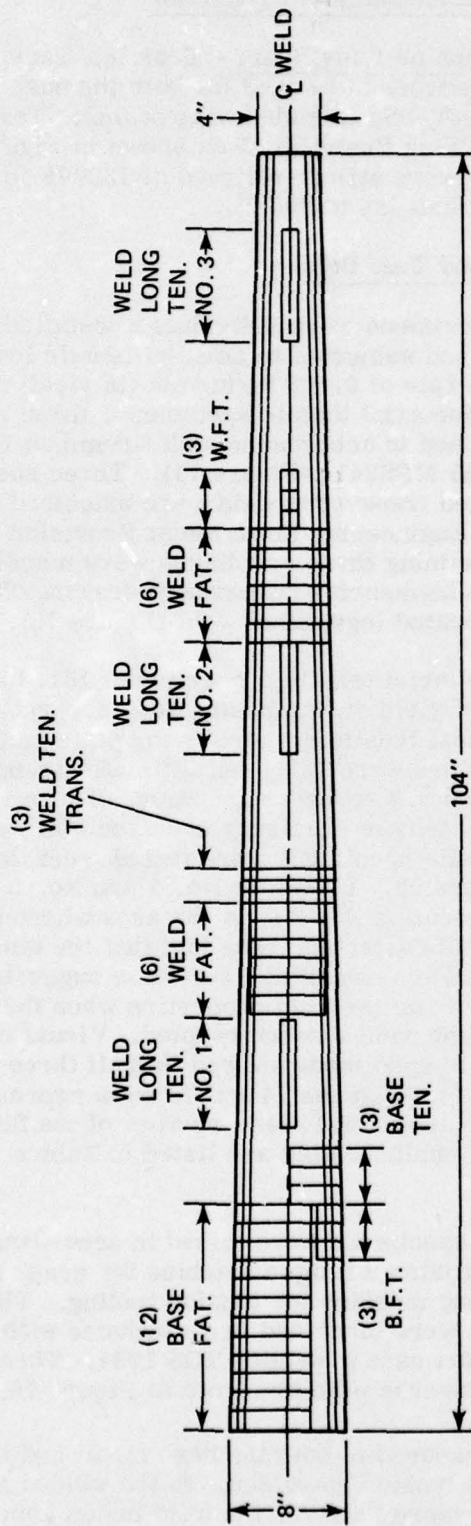

Figure 70 Test Specimen Location - Wing Beam No. 5

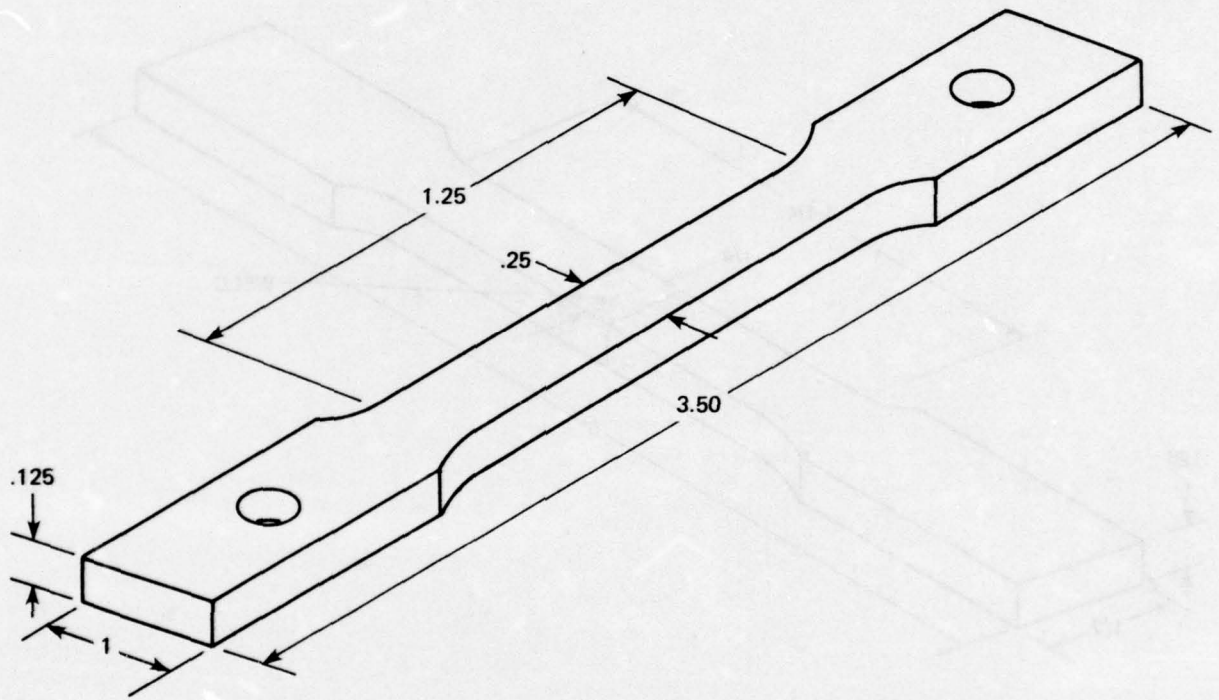

Figure 71 Base Metal Tensile Coupon (45MPS 241)

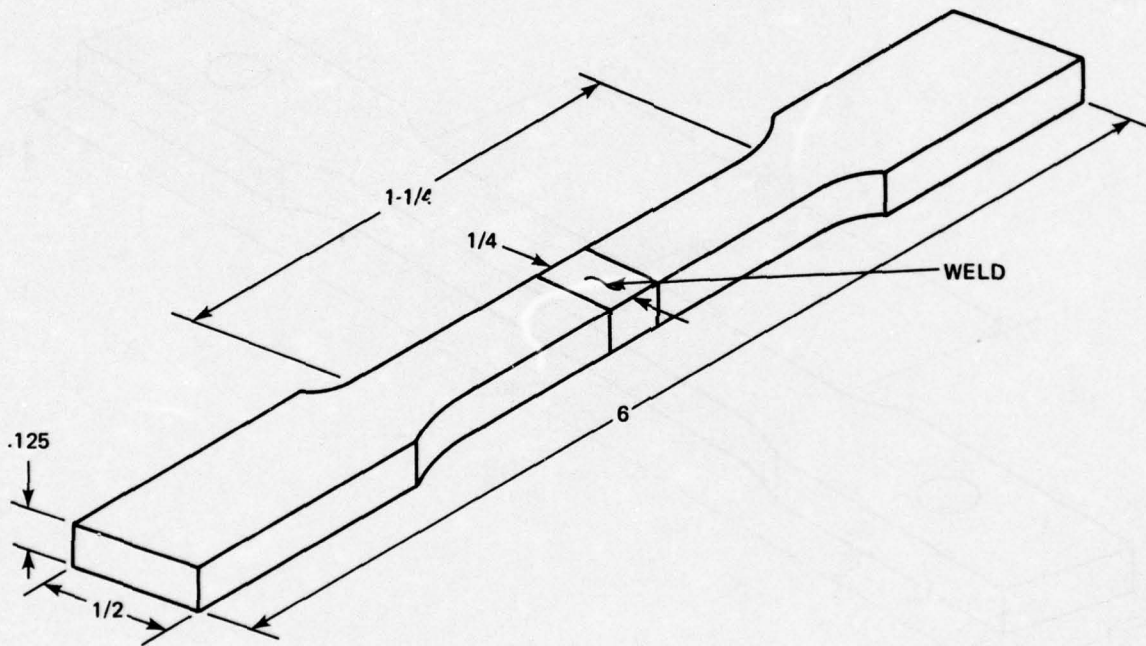

Figure 72 Transverse Weld Tensile Coupon (TGS 5350)

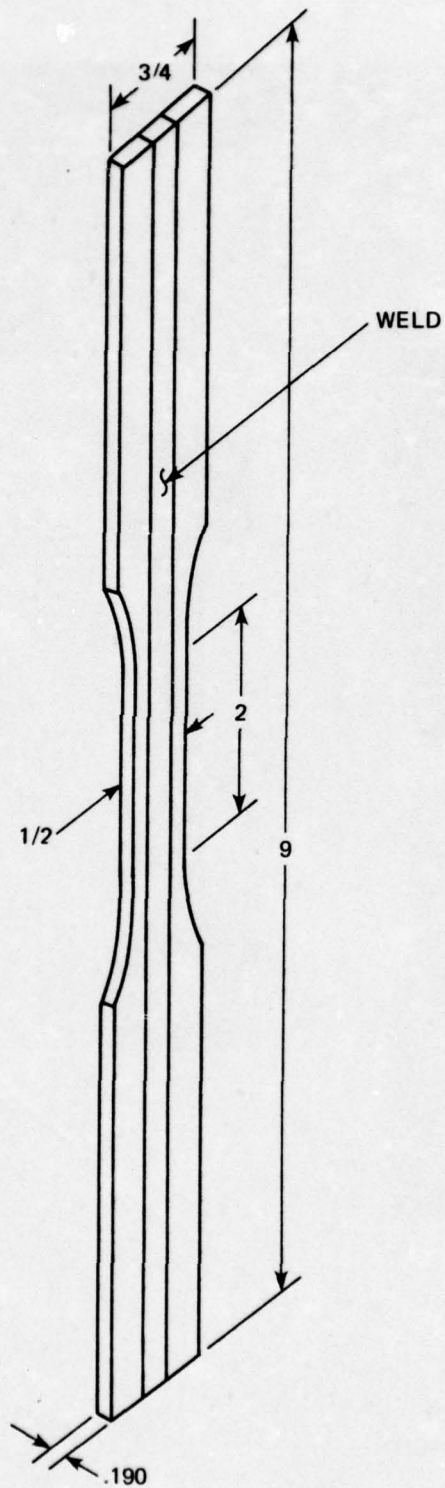

Figure 73 Longitudinal Weld Tensile Coupon (TGS 5359)

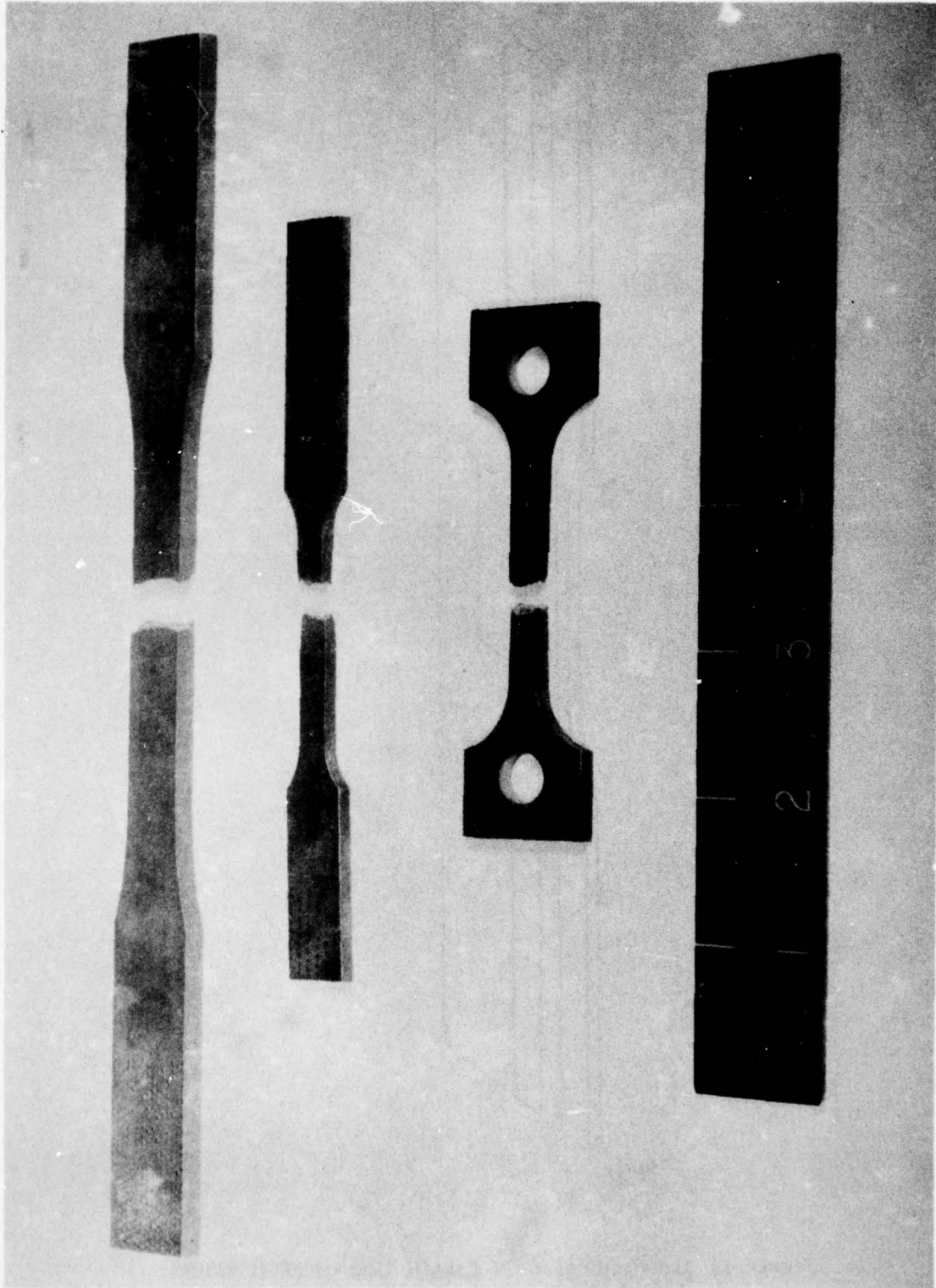

Figure 74 Wing Beam Tensile Coupons

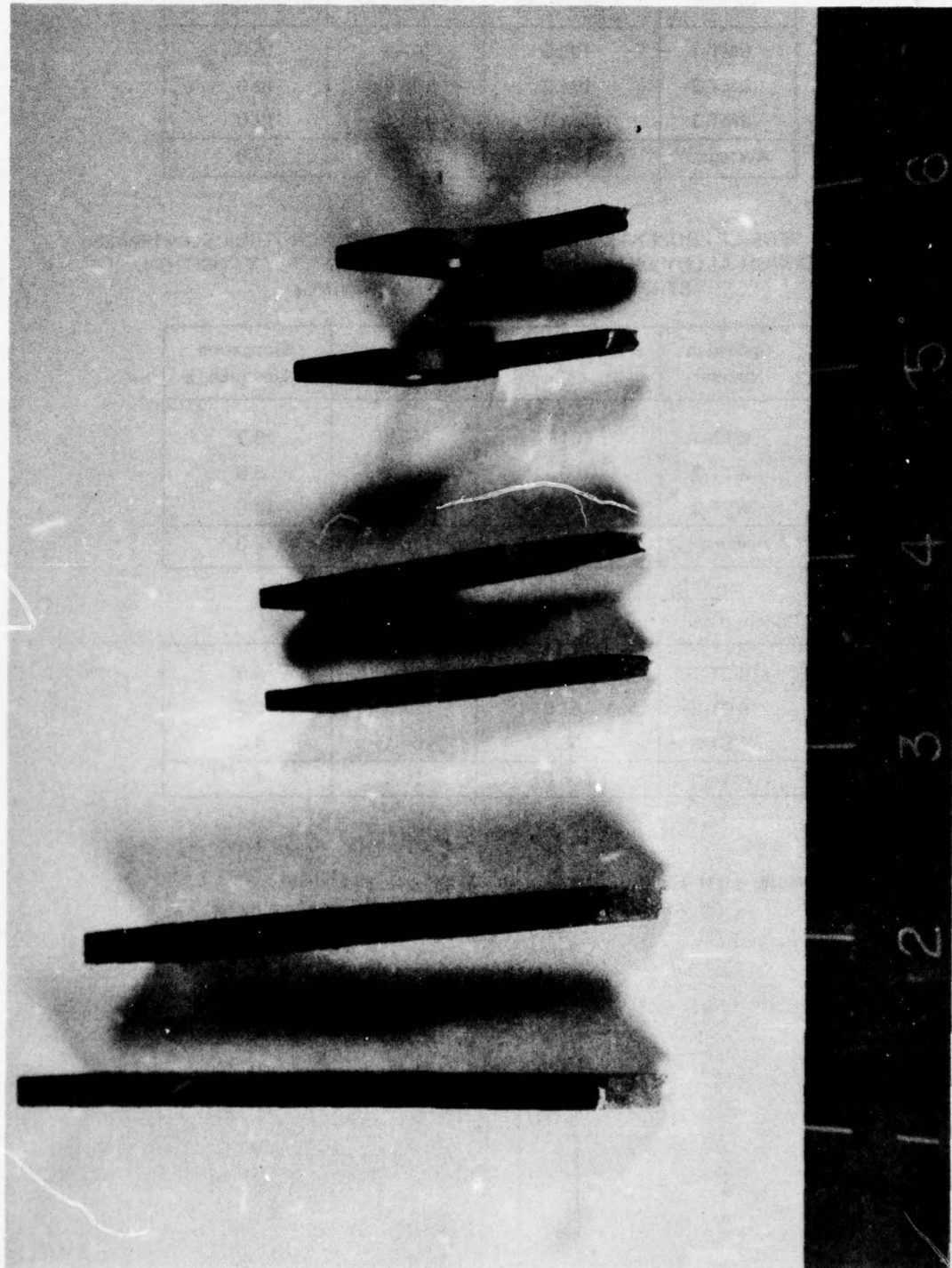

Figure 75 Close-Up View of Tensile Coupon Failure Location

TABLE 30. TENSILE PROPERTIES OF 0.300-INCH-THICK Ti-6Al-6V-2Sn TITANIUM ALLOY EXTRUSION BASE METAL (STRESS RELIEVED AFTER MACHINING)

| Specimen Number | Ultimate Tensile Strength, ksi | Yield Tensile Strength, ksi | Elongation in One Inch, % |
|-----------------|--------------------------------|-----------------------------|---------------------------|
| BMT-1           | 160.5                          | 147.4                       | 15.0                      |
| BMT-2           | 161.6                          | 148.4                       | 12.0                      |
| BMT-3           | 161.9                          | 148.1                       | 12.0                      |
| Average         | 161.3                          | 148.3                       | 13.0                      |

TABLE 31. TENSILE PROPERTIES OF SSB WELDED 0.300-INCH-THICK Ti-6Al-6V-2Sn TITANIUM ALLOY EXTRUSION (SQUARE BUTT JOINT, FLAT POSITION, STRESS RELIEVED AFTER MACHINING)

| Specimen Number | Ultimate Tensile Strength, ksi | Yield Tensile Strength, ksi | Elongation in One Inch, % |
|-----------------|--------------------------------|-----------------------------|---------------------------|
| WTT-1           | 161.7                          | 145.3                       | 10.0                      |
| WTT-2           | 160.7                          | 148.2                       | 8.0                       |
| WTT-3           | 162.5                          | —                           | 10.0                      |
| Average         | 161.6                          | 146.8                       | 9.3                       |

\*longitudinal

|         |       |       |                    |
|---------|-------|-------|--------------------|
| WCT-1   | 167.9 | 157.9 | 4.0                |
| WCT-2   | 167.9 | 157.5 | 6.0                |
| WCT-3   | 168.1 | 155.4 | 4.0                |
| Average | 168.0 | 156.9 | 4.7 <sup>(1)</sup> |

Note: (1) Elongation measured over a 2 inch gage length  
 (2) All transverse welded coupons failed in the base metal

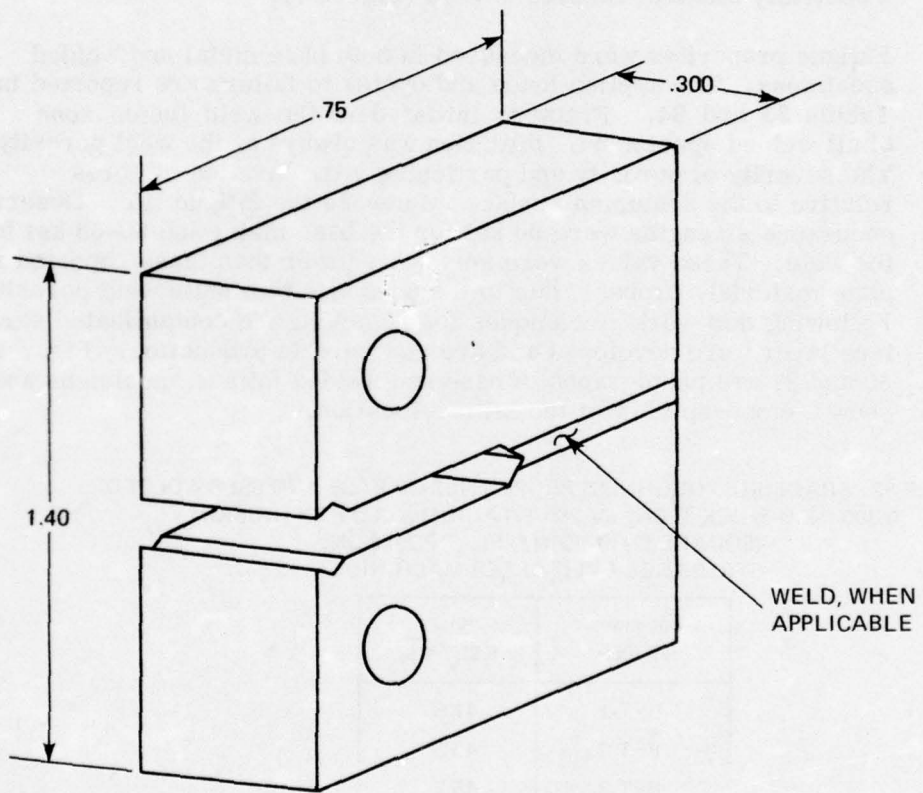

Figure 76 Fracture Toughness Specimen (TGS 1094)

27.3 ksi in. in the weld compare well with data available for commercially treated Ti-6Al-6V-2Sn titanium alloy. Figure 77 and 78 show a representative view of the test specimens and a close-up view of the failure specimens. Table 32 lists the test results for fracture toughness for welded and base metal properties.

- (3) **Fatigue** - The fatigue specimens were individually installed into a Sonntag fatigue machine and subjected to a cyclic tensile loading (stress ratio = 0.1) applied at a rate of 1800 cycles per minute until failure or until reaching the specified endurance limit ( $10^7$  cycles). The 23 test coupons were machined in accordance with Grumman Engineering Drawing 45MSP240. Twelve of the specimens contained a centrally located transverse weld (Figure 79).

Fatigue properties were measured in both base metal and welded specimens. The applied loads and cycles to failure are reported in Tables 33 and 34. Fracture initiated in the weld fusion zone of all welded specimens. Initiation was always at the weld porosity. The severity of porosity and particularly the location of pores relative to the specimen surface influenced the fatigue life. Observed endurance strengths were 90 ksi for the base metal and 50-55 ksi for the weld. These values were somewhat lower than those reported for plate material, probably due to the presence of minute weld porosity. Following this work, techniques for removing the contaminated surface layer were developed and are now used in production. Figures 80 and 81 are photographs of base and welded fatigue specimens and show a close-up view of the failure location.

TABLE 32. FRACTURE TOUGHNESS PROPERTIES OF BASE AND SSB WELDED 0.300-INCH-THICK Ti-6Al-6V-2Sn TITANIUM ALLOY EXTRUSION (SQUARE BUTT JOINT, FLAT POSITION, STRESS RELIEVED AFTER MACHINING)

| Specimen Number | K <sub>IC</sub><br>KSI√1 in. |
|-----------------|------------------------------|
| BFT-1           | 47.5                         |
| BFT-2           | 43.5                         |
| BFT-3           | 45.2                         |
| Average         | 45.4                         |

Welded

|         |      |
|---------|------|
| WFT-1   | 27.2 |
| WFT-2   | 29.1 |
| WFT-3   | 25.7 |
| Average | 27.3 |

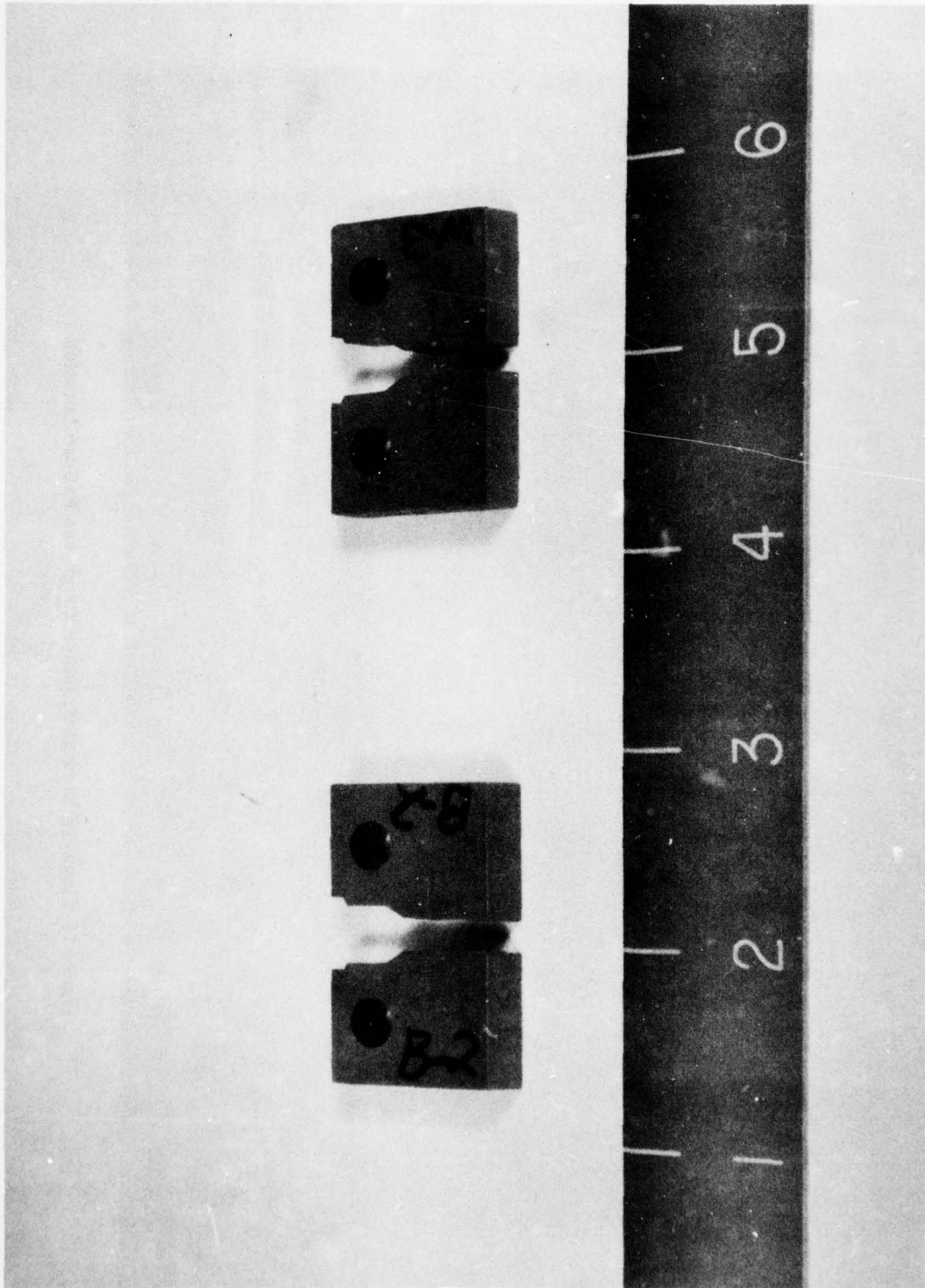

Figure 77 Wing Beam Fracture Toughness Specimen

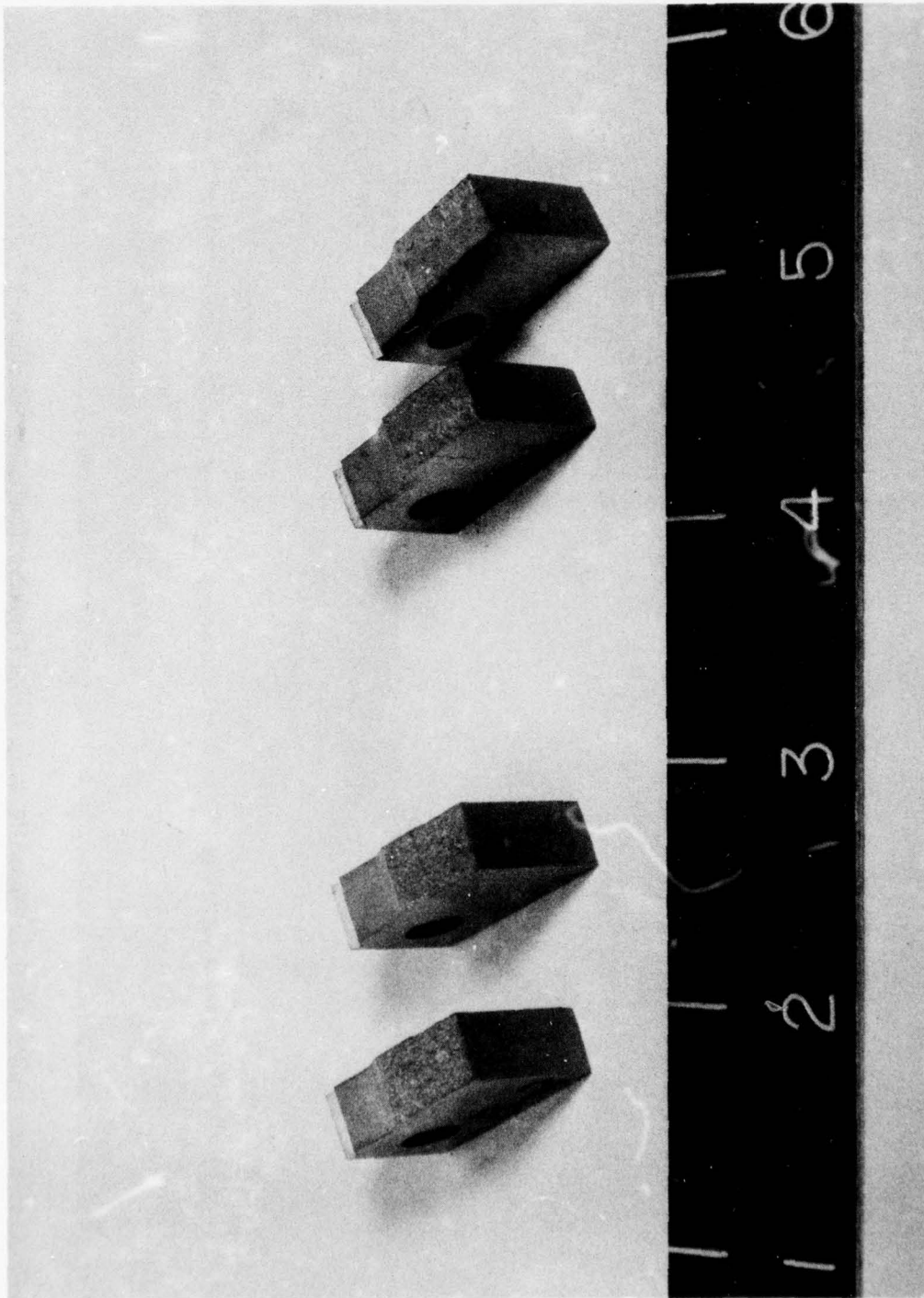

Figure 78 Close-Up View of Fracture Toughness Failure Location

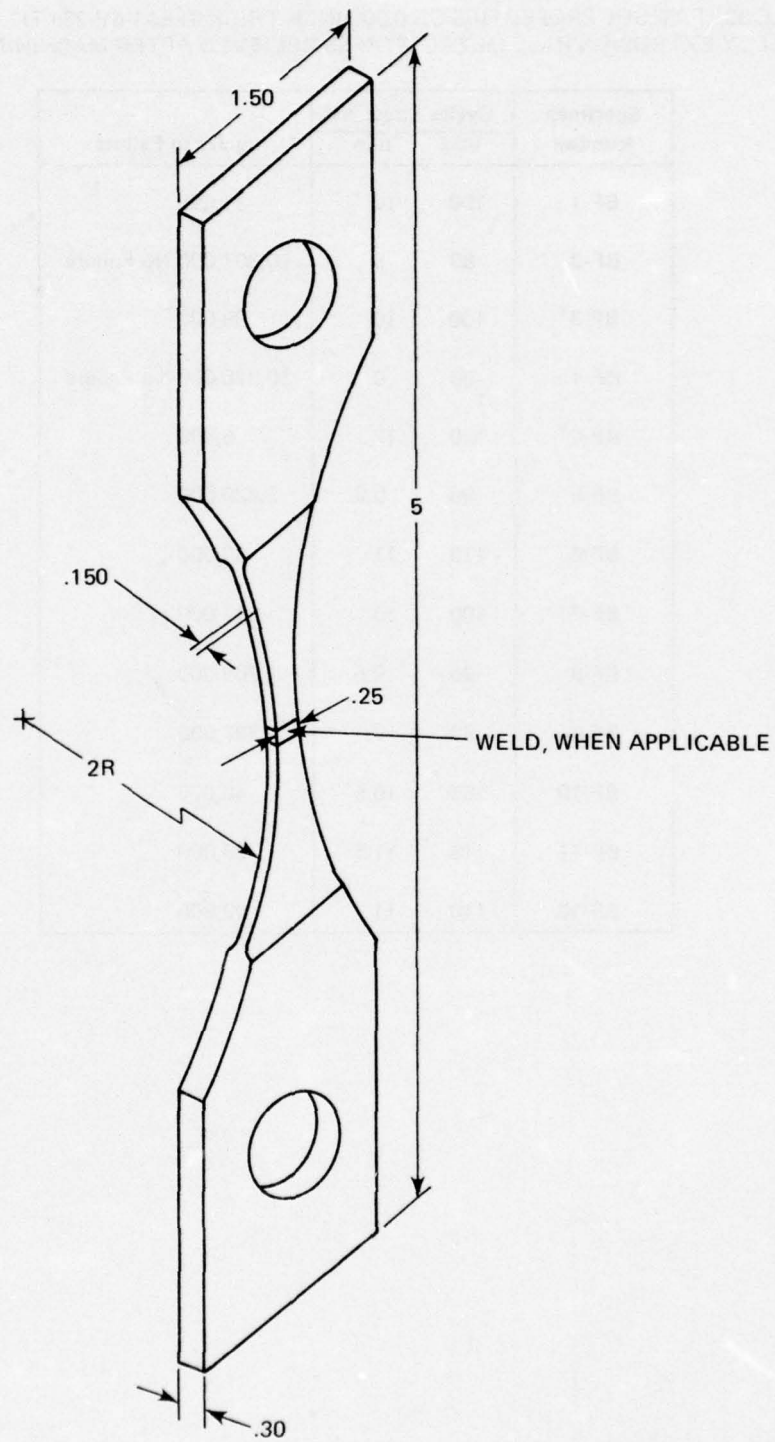

Figure 79 Fatigue Weld Test Specimen (45MPS 240)

TABLE 33. FATIGUE PROPERTIES OF 0.300-INCH-THICK Ti-6Al-6V-2Sn TITANIUM ALLOY EXTRUSION BASE METAL (STRESS RELIEVED AFTER MACHINING)

| Specimen Number | Cycles Stress, ksi |      | Cycles to Failure     |
|-----------------|--------------------|------|-----------------------|
|                 | max                | min  |                       |
| BF-1            | 100                | 10   | 31,000                |
| BF-3            | 80                 | 8    | 10,301,000 No Failure |
| BF-3*           | 100                | 10   | 99,000                |
| BF-4            | 90                 | 9    | 10,320,000 No Failure |
| BF-4*           | 120                | 12   | 6,000                 |
| BF-5            | 95                 | 9.5  | 3,820,000             |
| BF-6            | 110                | 11   | 32,000                |
| BF-7            | 100                | 10   | 347,000               |
| BF-8            | 95                 | 9.5  | 1,765,000             |
| BF-9            | 90                 | 9    | 387,000               |
| BF-10           | 105                | 10.5 | 46,000                |
| BF-11           | 115                | 11.5 | 26,000                |
| BF-12           | 110                | 11   | 42,000                |

TABLE 34. FATIGUE PROPERTIES OF SSEB WELDED 0.300-INCH-THICK TITANIUM ALLOY EXTRUSION (SQUARE BUTT JOINT, FLAT POSITION, STRESS RELIEVED AFTER MACHINING)

| Specimen Number | Cycles Stress, ksi |     | Cycles to Failure     | Failure Location                        |
|-----------------|--------------------|-----|-----------------------|---|
|                 | max                | min |                       |   |
| WF-1            | 80                 | 8   | 80,000                | Surface, no visible defect              |
| WF-2            | 70                 | 7   | 275,000               | (S), pores 0.002-0.003"                 |
| WF-3            | 60                 | 6   | 120,000               | (S), 2 pores 0.004 & 0.002"             |
| WF-4            | 60                 | 6   | 2,111,000             | Corner (S), pore 0.001"                 |
| WF-5            | 55                 | 5.5 | 95,000                | Severe porosity (~ 50); (S) 0.010"      |
| WF-6            | 55                 | 5.5 | 776,000               | Interior (I), pores (~ 20) 0.001-0.003" |
| WF-7            | 50                 | 5   | 10,286,000 No Failure | (I), pore 0.005"                        |
| WF-7*           | 90                 | 9   | 221,000               |   |
| WF-8            | 50                 | 5   | 7,356,000             | (I), pore 0.005", 0.020"                |
| WF-9            | 55                 | 5.5 | 16,162,000 No Failure | (S), pore 0.001"                        |
| WF-9*           | 100                | 10  | 44,000                |   |
| WF-10           | 50                 | 5   | 10,098,000 No Failure | (S), pores 0.001-0.007" (~ 5)           |
| WF-10*          | 95                 | 9.5 | 1,000                 |   |
| WF-11           | 60                 | 6   | 7,804,000             | (I), pores (~ 15), 0.003" range         |
| WF-12           | 75                 | 7.5 | 41,000                | (S), pore 0.003"                        |

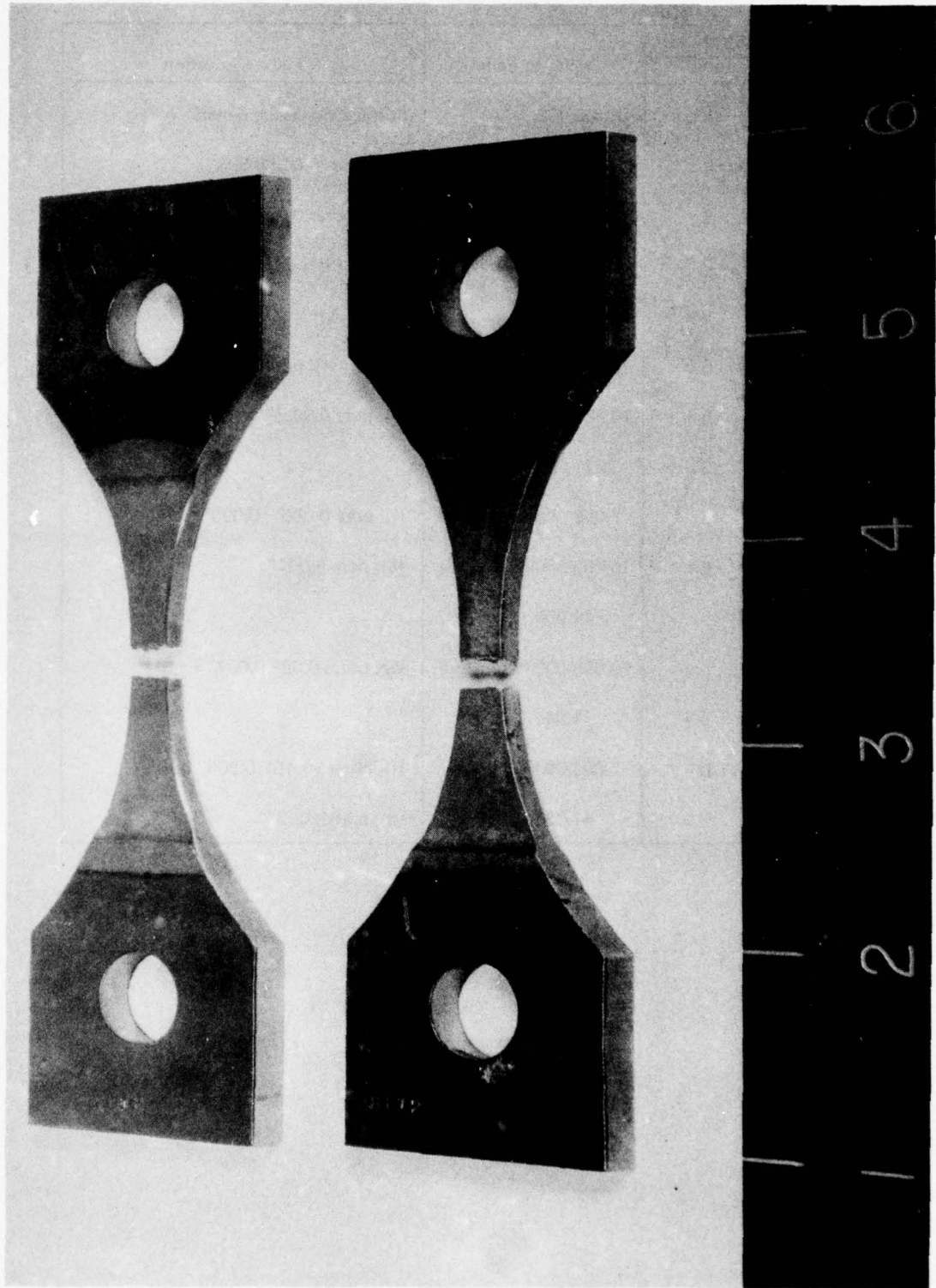

Figure 80 Wing Beam Fatigue Test Specimen

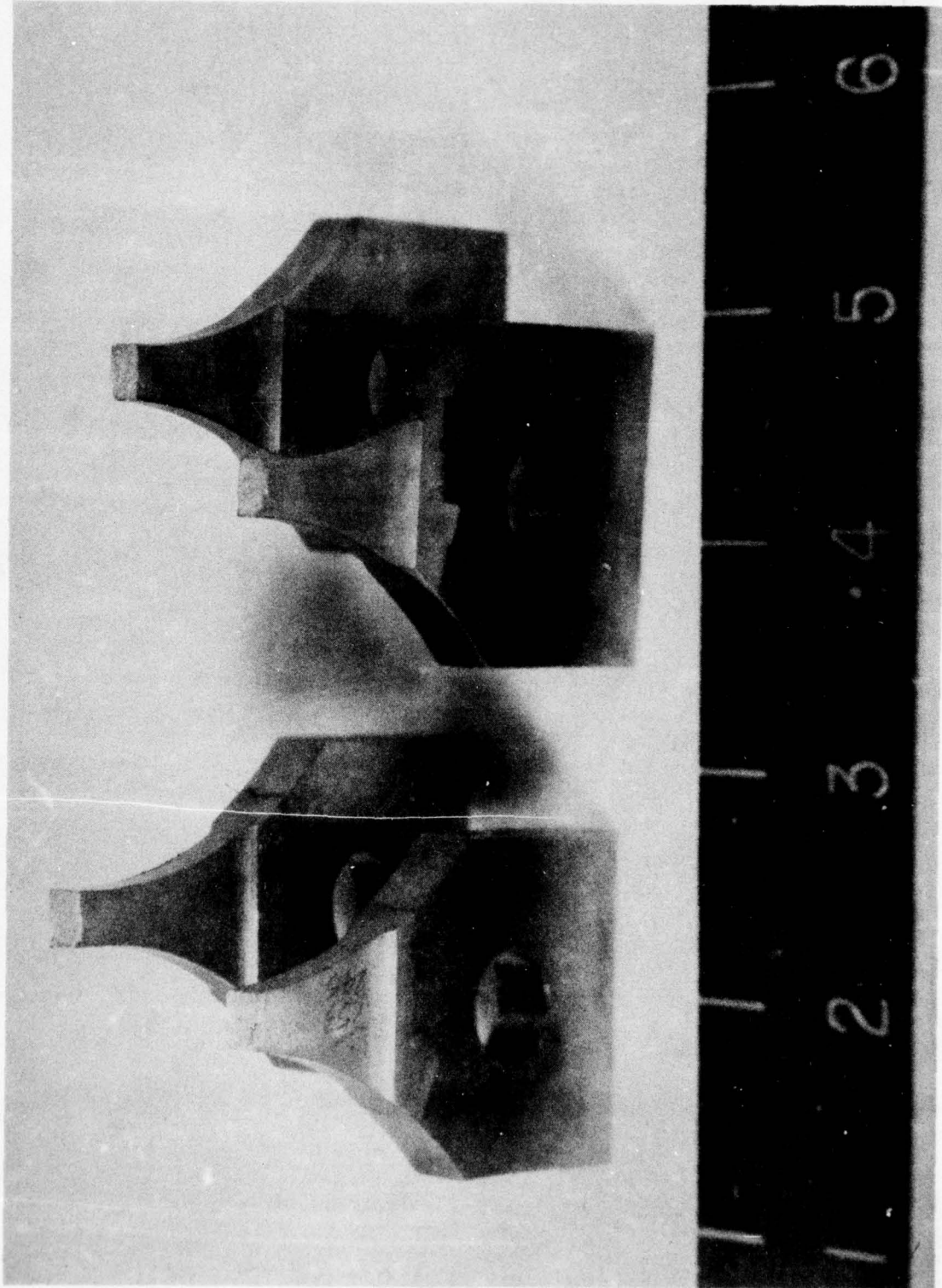

Figure 81 Close-Up View of Fatigue Failure Location

## SECTION V

### CONCLUSIONS AND RECOMMENDATIONS

#### A. CONCLUSIONS

##### 1. Flat Plate Welding Fixture (Phase II)

The flat plate weld fixture was used for long length welds (13 feet), short test panels (2 feet), seal life wear study, generating weld data and mechanical property data.

- Over 35 welds, 13 feet in length were made in one-inch-thick 2014-T651 Aluminum
- (8) two-foot-long test panels welded in one-inch-thick 2014-T651 Aluminum
- 2 welds 12 feet in length were welded in 0.880-inch-thick Ti-6Al-4V Titanium
- (8) two foot long test panels welded in 0.880-inch-thick Ti-6Al-4V titanium
- 5 welds, 13 feet in length were welded in a 0.300-inch-thick Ti-6Al-4V Titanium
- Seal life/wear study conducted on the flat plate fixture was successful on aluminum plate and had limited results on titanium plate
  - 350 feet of aluminum plate was welded successfully with one set of sliding seals
  - Titanium results on one-inch-thick plate were poor since only about 25 ft could be welded with one set of seals. Excessive seal wear was caused by high heat input, high weld bead crown, and poor vacuum capability of the fixture.
  - Titanium results on 0.300-inch-thick plate were acceptable since 65 feet of plate was welded with one set of sliding seals.
- Short test panels welded in aluminum and titanium alloys passed visual and radiographic inspection. Tensile testing conducted on selected weldments yielded the following results:
  - Aluminum            58.0 Ksi ultimate strength - 80% of base metal  
2014-T651            52.4 Ksi yield strength - 78% of base metal
  - Titanium            148.2 Ksi ultimate strength - 100% of base metal  
Ti-6Al-4V            143.8 Ksi yield strength - 100% of base metal

- Fixture capabilities.
  - Welding on this fixture demonstrated capability to move a part beneath a stationary SSEB weld head increasing maximum welding length from 2 feet to 13 feet
  - The fixture mounted on dual and single roundways on a weld table was accurately aligned with the SSEB weld head. A laser optical alignment check verified travel motion of the fixture
  - The weld plates were clamped securely for vacuum sealing on the fixture. The plates were held rigid during GTA seal pass welding and SSEB Welding. Flatness of the weld plate was also maintained by the weld fixture
  - Vacuum sealing of the weld back up area was adequately maintained for aluminum plate welding
  - Cover plate set up on the flat plate fixture for the short test panel welding demonstrated equipment capability to vacuum seal any size plate up to 13 feet in length
- Fixture Limitation - The following fixture limitations were noted during the course of the welding studies conducted on the flat plate weld fixture
  - Vacuum sealing of back up area for titanium welding was not adequate enough to overcome vapors generated during welding. The vacuum pumping lines were too long and small in diameter to efficiently handle the sharp rise in vacuum pressure
  - The backup chamber area (4 inches wide by 3 inches deep) was not large enough to provide for initial vapor expansion during welding. This caused vacuum pressure to rise from 25 microns to 250 microns for aluminum welding, and from 25 microns to 500-750 microns for titanium welding. Future designs should allow for backup chamber dimensions which allow use of larger diameter pumping ports.
  - A cold trap addition to the backup bar area was required to increase vacuum capability for initial pumping operation. The cold trap increased pumping efficiency by shortening pumping time from 25 to 3 minutes time.
  - Weld seam alignment required special set up procedures for positioning of the SSEB weld head. Back-lash on the ram-manipulator drive axis (X-axis) caused missed seam alignment on the butt welds.
  - Close-in support tooling of weld plate was not possible on the flat plate weld fixture. The SSEB weld head assembly requires an open area 14 inches wide to slide over the weld seam.
  - Travel speed of the welding fixture was limited from 40 to 80 ipm. Lower travel speed ranges could not be held with a uniform travel motion.

## 2. Cylinder Welding Fixture (Phase II)

The cylinder weld fixture was used to demonstrate local, internal support tooling, vacuum sealing of weld backup and head modifications required to make the cylinder weld.

- A 166 inch-long weld was successfully made on the aluminum cylinder
- Internal support tooling adequately maintained cylinder rigidity during the GTA seal pass and SSEB weld. Jack screws in the backup bar/vacuum ring held the cylinder standoff dimensions from the ring and assured accurate circumference dimensions within  $\pm .060$  inches
- Accurate positioning of the fixture and cylinder on the Aronson turnable positioner held circumference of the cylinder within  $\pm 1/8$  inch for vacuum sealing of the curved head plate/sliding seals
- Inflatable "O" ring vacuum seals were capable of sealing the cylinder to a vacuum level of 125 microns which was adequate for welding.
- A flexible ball joint swivel fitting was employed on the vacuum lines in order to decrease pumping line lengths and provide rotation of vacuum lines
- A curved head plate was fabricated and used to form the sliding seals of a six-foot radius of curvature. This formed the sliding seals for proper sealing against the outside of the cylinder. Vacuum levels of 15-25 microns were held in this area during welding.
- The weld seam of the cylinder was leveled to within  $\pm .030$ " tolerance
- The GTA seal pass was capable of sealing the weld seam for the vacuum requirements. The light fusion weld was able to weld the mismatch and gap in the weld seam caused by machining and forming operations.

Cylinder Welding Fixture Limitations - Several machining, fixturing and welding problems were experienced in the set-up and welding of the cylinder.

- Forming and MIG (Metal Inert Gas) Welding of the cylinder made (4) flat areas on the cylinder circumference. These areas were difficult to set up on the weld fixture and cause a head vacuum seal problem in these weld seam areas
- Poor clamping on the machining for the weld seam preparation led to a 0.100-inch-gap in the weld seam. This gap which was approximately eight feet long could not be closed by clamping. The GTA seal pass weld partially closed this gap and successfully vacuum sealed the area for SSEB welding.
- Vacuum sealing of the head/sliding seals against the cylinder surface required special positioning of the boom and limit switch. The four flat areas adjacent to the MIG seam welds were difficult to vacuum seal.

- Vacuum pumping lines were too long with a small I.D. on the tube size. Two vacuum pumps were required to lower the vacuum in the back weld area to a level of 125 microns. This can be corrected by increasing the pumping port size and shortening line lengths.
- The cylinder weldment ended at 166 inches of weld because of two large tears in the sliding seals. This was caused by an eruption on the GTA repair weld when the SSEB weld passed over the repaired area.

### 3. Special Shapes Welding Fixture (Phase II)

The special shapes weld fixture was used to demonstrate SSEB capability to weld a complex shape. Special shape seals were molded to vacuum seal the part which extended through the chamber sides.

- Aluminum and titanium tee sections successfully passed visual inspection for weld bead appearance and radiographic inspection for weld quality
- Silicone rubber seals were injection molded and used to seal the tee sections in the round inserts on the fixture sides. Vacuum levels attained for welding the fixture were 10-15 microns.
- Viewing of the SSEB weld beam, made possible by a four-inch lead glass viewing port, aided in the beam alignment on the tee section weld seam.
- GTA seal pass operation was not required for vacuum sealing the tee section since they were fixtured inside a vacuum box structure.
- Two weld pump-downs were required to weld the tee sections because it was necessary to remove the top cover off the fixture and reposition the tee sections for the second weld. The fixture for holding start and stop tabs was removed and an end tab for the second weld inserted at this time.

### 4. Preheat Steel Welding Fixture

SSEB/Slot welding was developed on a company funded project for SSEB production welding of F-14 Wing Beam (See Section E). The slot welding technique was utilized on the Preheat Steel Weld Fixture in place of the bead-through-cover sheet method proposed at the beginning of the program.

- Preheating of HY 130 steel plate before welding eliminates cracking during and after welding. 0.880-inch-thick-plate which was preheated to 200°F prior to welding, successfully passed radiographic and magnetic particle inspection.
- Preheating of D6AC steel plate before welding was conducted at 350°F and the welds passed radiographic and magnetic particle inspection.
- Tensile testing of selected weldments yielded the following results.
 

|          |  |
|----------|--|
| - HY 130 | 140.4 Ksi ultimate strength - 100% of base metal |
|          | 132.6 Ksi yield strength - 100% of base metal    |
| - D6AC   | 142.1 Ksi ultimate strength - 99% of base metal  |
|          | 114.2 Ksi yield strength - 100% of base metal    |

- Preheating used for steel welding did not affect vacuum capability of the fixture or cause any detrimental affect on the "O" rings or sliding seals on the preheat fixture.
- Preheating curves were developed for preheat time and temperature requirements to preheat materials between 150°F and 400°F
- The benefits derived from SSEB/Slot welding, described below, provide an alternative method of flat-plate welding since it eliminates most of the problems associated with the flat-plate weld fixture.
  - Eliminates the need for the GTA seal pass welding operation
  - Isolates the seals from the workpiece. This will virtually eliminate seal wear, give a considerable cost savings, and afford greater adaptability and accessibility for part clamping devices
  - Provides faster turn-around time from part cleaning to final welding operation which reduces the possibility of contamination by the environment or by the GTA welding operation.
  - Adapts one vacuum chamber for welding flat plate, extrusions, rib-stiffened panels and angle configuration of various sizes and lengths
  - Provide vacuum environment afforded by a large vacuum chamber area to contain the workpiece.

#### 5. Wing Beam Welding (Phase III)

SSEB/Slot Welding techniques can be successfully used to produce aerospace production parts. Five, nine-foot long, F-14 wing beams were welded from 0.300-inch-thick Ti-6Al-6V-2Sn titanium alloy extrusion.

- The Phase III demonstration part (F-14 Wing Beam) selected in consultation with the Air Force Project Manager was successfully welded and subjected to radiographic and mechanical property tests.
- Wing Beam welds exhibited excellent weld bead appearance and were acceptable per witness line inspection and weld bead dimensions.
- All wing beams were radiographically inspected. Wing Beams 1 through 4 had scattered linear porosity in the welds. Wing Beam No. 5 passed radiographic inspection satisfactorily.
- Wing Beam No. 5 was tested for mechanical property data. Fracture toughness for welded material was 27.3 Ksi in with a base average of 45.4 Ksi in and a fatigue endurance limit of 50-55 Ksi. Weld failures initiated as porosity attributed to extrusion process contamination not completely eliminated by material machining or cleaning.

- Tensile testing of Wing Beam No. 5 was conducted for base metal, transverse and longitudinal weld specimens

|                     | Ultimate<br>Strength | Yield<br>Strength |
|---------------------|----------------------|-------------------|
| - Base Metal        | 161.3                | 148.3             |
| - Traverse Weld     | 161.6                | 146.8             |
| - Longitudinal Weld | 168.0                | 156.9             |

## B. RECOMMENDATIONS

### 1. Flat Plate Welding Fixture

- In future designs the vacuum pumping capacity of the system should be changed to increase pumping speed and efficiency. This can be accomplished as follows:
  - Increase the dimension (volume capacity) of the backup bar area to allow for vapor expansion caused by welding
  - Shorten pumping lines by centrally locating vacuum pumps
  - Increase vacuum hose inside diameter. Pumping speed and efficiency is directly related to the I.D. of the vacuum lines.
- Make appropriate changes to the table drive system to increase the travel speed range to allow welding from 10 IPM to 60 IPM travel. This can be done by the following methods:
  - Change drive gears/sprockets on the chain drive, or angle and pitch of gear rack.
  - Change the gear reduction box (Ohio-D4 gear reducer)
  - Change rack and pinion system to a ball screw drive providing a smoother travel motion.
- When recommended changes have been made to the flat plate fixture the following tasks should be performed:
  - Welding of aluminum at slower travel speeds (10 to 30 IPM) to determine maximum thickness capability and to evaluate wider welds. (Wide beam welding) - higher heat inputs.
  - Welding of titanium from 0.300 to 1.00 inch thick plate to determine thickness capability and a more realistic seal wear evaluation on titanium.
  - Additional mechanical property data should be generated including fatigue and fracture toughness data.
- Close-in support tooling required for the GTA seal pass weld should be added to the fixture. This would eliminate removal of the GTA welded plate required to insert the "O" ring seals.

- Evaluate inflatable seals in conjunction with the above recommendation and for sealing of warped and or bowed plates.
2. Cylinder Welding Fixture
- The vacuum pumping capacity of the system should be increased to lower the vacuum level in the backup bar area from the present 125 microns to below 50 microns of Hg.
  - Modify head assembly dimensions to a smaller unit so that head sealing on the cylinder will not be affected by "out of roundness" of the cylinder.
  - Such a modified head assembly could be used on the existing cylinder to make bead-on-plate weldments evaluating head sealing.
3. Special Shapes Welding Fixture
- Increase slot in cover plate from 3 inches to 10 inches and use present slot weld sealing techniques to make longer welds.
  - Modify fixture to make fillet welds on tee sections to weld the vertical leg to the top cross member.
  - Develop tooling for quick assembly and rotation of parts using less critical tolerances for sealing, alignment and set procedures.
  - Develop additional sealing methods in place of the molded seals. Use external sealing methods instead of the internal seals.
4. Preheat Steel Welding Fixture
- A spacer plate could be adapted to the top of the fixture to allow for welding of materials from one of three inches in thickness
  - Welding of additional crack sensitive high strength high alloy steels should be investigated
  - Cooling and insulation of the fixture and cover plate should be used for preheat/postheat of steel which requires heating for extended times.

## APPENDIX I

### SLIDING-SEAL ELECTRON-BEAM WELDING OF ALUMINUM, TITANIUM AND STEEL ALLOYS; REQUIREMENTS SPECIFICATION FOR

1. SCOPE - This specification establishes the requirements for Sliding-Seal Electron-Beam Welding of Aluminum, Titanium and Steel alloys.

2. APPLICABLE DOCUMENTS

2.1 Government Documents. - The following documents (referred to under the basic number in subsequent paragraphs) shall form a part of this specification to the extent specified herein:

|               |  |
|---------------|--|
| Q-A-51D       | Acetone, Technical   |
| MIL-P-27401   | Nitrogen, Propellant Pressurizing Agent  |
| MIL-P-27407B  | Helium, Technical  |
| MIL-A-18455B  | Argon, Technical   |
| MIL-STD-20    | Welding Terms and Definitions  |
| MIL-STD-453   | Inspection, Radiographic   |
| MIL-I-6866B   | Inspection, Penetrant, Method of   |
| MIL-I-6868D   | Inspection, Magnetic Particle  |
| MIL-T-5021D   | Tests; Aircraft and Missile Welding Operators' Qualification                   |
| MIL-T-9046F   | Titanium and Titanium Alloys, Sheet, Strip and Plate                           |
| MIL-S-5002B   | Surface Treatments and Metallic Coatings for Metal Surfaces of Weapons Systems |
| MIL-W-80119   | Electron Beam Welding Machine, Vacuum Type                                     |
| MIL-S-16216G  | HY 130 Alloy Steel Plate   |
| MIL-R-5632B   | Rods and Wire, Steel, Welding (For Aircraft)                                   |
| MIL-H-006875E | Heat Treatment of Steels (Aerospace Practice, Process For)                     |

2.2 AMS Documents. - The following Aerospace Material Specification (AMS) shall form a part of this specification to the extent specified herein:

|           |   |
|-----------|---|
| AMS 4029E | Aluminum Alloy Sheet and Plate (2014, -T6 Sheet, -T651 plate) |
| AMS 4190B | Aluminum Alloy Wire, Welding (5.25 Si (4043))                 |

AMS 4911B Titanium Alloy Plate, Sheet and Strip (Ti-6Al-4V) Annealed  
AMS 4956A Titanium Alloy Wire, Welding (Ti-6Al-4V)

2.3 Other Documents. - The following documents shall form a part of this specification to the extent specified herein:

NAS 986 Electron Beam Welding Machine  
ASTM-E8-66 Tension Testing of Metallic Materials, Standard Methods of  
GM 1013 Steel, Type D6AC

3. REQUIREMENTS - Where Engineering drawings or specifications require sliding-seal electron-beam welding of aluminum, titanium or steel alloys, it shall be accomplished as follows:

3.1 Qualified Welding Operators. - Welding operators for sliding-seal electron-beam welding of aluminum, titanium and/or steel alloys per this specification shall be qualified in accordance with the procedures established in MIL-T-5021D or appropriate company specification.

3.1.1 An operator undergoing qualification testing may weld a certification plate according to a pre-established schedule as part of the test. If the operator successfully qualifies, the weld schedule shall be automatically certified.

3.2 Special Requirements. -

3.2.1 Materials and Processes Engineer as specified herein shall mean Cognizant Welding Engineer.

3.2.2 Calibration. - Each sliding-seal electron-beam welding equipment station shall comply with the requirements approved by Quality Control.

3.3 Classification. - Weld classification shall be based on the function of the sliding-seal electron-beam welded joint. Welds shall be classified on the Engineering drawing as follows:

Class A - Used in joints of high and medium stress level, of which the single failure of the weapons system or one of its major components, loss of control, unintentional release of, or inability to release any armament store, failure of gun installation components, or which may cause significant injury to occupants of the manned weapons system.

Class B - All joints other than Class A.

3.4 Equipment. - The following equipment, as approved by Materials and Processes Engineering, shall be used.

3.4.1 Electron Beam Welding Equipment. - The sliding-seal electron-beam welding equipment shall conform to NAS 976 or other appropriate military or company specification and shall be capable of producing welds meeting the requirements of Quality Assurance, Paragraph 4.0.

- 3.4.2 Jigs, Fixtures and Vacuum Chambers. - All holding fixtures for sliding-seal electron-beam welding shall be capable of holding parts in proper alignment, maintaining desired configuration and tolerances during welding, providing back-up as required, and allowing required work space between the workpiece and the electron gun. BACK-UP MATERIAL used to deflect or absorb residual electron-beam energy shall be of the same alloy as the part being welded.
- 3.4.2.1 Special Notes. - No magnetic materials may be used for jigs and/or fixtures without the specific written approval of Materials and Processes Engineering.
- 3.4.2.2 Degaussing. - Ferro magnetic materials shall be demagnetized prior to welding.
- 3.4.3 Inert gas welding equipment for seal welding and auxiliary shields shall be capable of maintaining a contaminant-free atmosphere of helium and/or argon gas having a maximum dew point of -75°F.
- 3.5 Materials. - Only the following materials shall be used:
- 3.5.1 Base Metals. - Only those materials listed in Table 35 are approved for welding in accordance with this specification and shall be in the condition specified on the Engineering drawing prior to welding. Materials and material combinations not listed in Table XXXV shall not be welded without prior specific approval of Materials and Processes Engineering.
- 3.5.2 Filler Metals. - Only filler metals listed in Table 35 shall be used. Filler Metals which are not listed in Table 35 shall be used only with the specific approval of Materials and Processes Engineering. When filler metal is required, it shall be specified on the Engineering drawing.
- 3.5.3 Inert Gases. - The following inert gases or any combination of gases used for seal welding and shielding atmosphere, when required, as specified on the Engineering drawing:
- (a) Helium per MIL-P-27407
  - (b) Argon per MIL-A-18455
  - (c) Nitrogen per MIL-P-27401
- 3.5.4 Cleaning Materials. - Cleaning materials shall be approved by Materials and Processes Engineering. Some of these materials are specified below:
- (a) Acetone per Q-A-51
  - (b) Nylon wipers - source open
  - (c) Other chemical cleaners as approved by Materials and Processes Engineering

- 3.5.5 Marking Inks. - Marking inks shall be approved by Materials and Processes Engineering for specific materials only. Some of these marking inks are specified below:
- (a) F-100 - Organic Products Co., P. O. Box 428-TR, Irving, Texas
  - (b) 73X - Independent Ink Co., 14705 South Avalon Boulevard, Gardena, California, 90247
- 3.6 Qualified Personnel. - Personnel performing welding, per this specification, shall be qualified under the cognizance and supervision of Materials and Processes Engineering for the particular alloy involved. The qualification shall be approved by the Quality Control Laboratory. Upon qualification, the names of the qualified personnel shall be forwarded to Quality Assurance, who shall maintain a list of these names.
- 3.6.1 Personnel qualified per Paragraph 3.6 shall be assigned a stamp with a number or symbol that shall be used to identify all weldments made by them.
- 3.6.2 The Production Department shall forward the names of all welding operators to the Medical Department. Yearly eye examinations shall be given welding operators.
- 3.7 Certification of Welding Procedure. - Prior to production welding, Materials and Processes Engineering shall prepare a weld schedule per Table 36 for each penetration weld joint configuration and for each cosmetic pass configuration.
- 3.7.1.1 For the penetration weld joint, a test plate per Figure 82 shall be welded in accordance with the prepared weld schedule and submitted to Quality Control for testing Paragraphs 4.1 through 4.4.1.2.
- 3.7.1.2 For the cosmetic pass configuration, a test plate per Figure 83 shall be welded in accordance with the prepared weld schedule and submitted to Quality Control for testing Paragraph 4.4.2. The cosmetic pass configuration shall be made as a bead-on-previously deposited-full-penetration weld.
- 3.7.1.3 Upon acceptance of the test plate for either a full penetration or/and cosmetic pass weld, Quality Control shall certify the weld schedule and forward certified copies to Materials and Processes Engineering for distribution.
- 3.7.1.4 Test Plate Preparation and Testing. - The weld schedule certification test plate shall be of the same material and condition, prepared and cleaned in the same manner as the production part. Welding shall be performed using the same welding position and joint configuration (thickness and angle) representative of that used on the production part.

Welding operators ID number shall be metal impression stamped on the test plate except when welding operator is undergoing qualification in which case his badge number shall be used. Testing shall be done per Paragraph 4.4.

- 3.7.2 Weld Schedule Recertification. - Recertification of weld schedules shall be required when any change is made to the following parameters:
- (a) When test welds fail to qualify
  - (b) When a change in base metal thickness is in excess of  $\pm 5$  percent is made (not applicable to cosmetic pass weld configurations).
  - (c) When a change in joint design is made (not applicable to cosmetic pass configurations).
  - (d) When the welding position is changed (relation between the gun angle and the work angle).
  - (e) When a change is made in any one of the critical machine settings, Items 13, 15 through 20, or in the energy input, Item 23, of Table 36. One exception, Item 19 (beam deflection switch) shall not be considered critical when used for the purpose of scanning or beam alignment.
- 3.7.3 Joint Preparation. - Joints shall be prepared to conform to the requirements specified on the Engineering drawing.
- 3.7.3.1 Pre-Weld Fit-Up. - Edges shall be machined square and parallel to ensure proper fit-up. Joints must have no rounded-off edges, but must be deburred after machining. Unless otherwise specified, faying surfaces of joints shall have surface finishes not rougher than 125 RMS. Joints shall have metal-to-metal contact where possible. When gaps do occur, the following restrictions shall apply:
- (a) For joints where no filler metal is added during seal pass welding, the maximum root opening shall be 0.010-inch wide.
  - (b) For joints where filler metal is to be added during seal pass welding, the maximum root opening shall not exceed 0.015-inch wide.
- 3.7.3.2 Deviation of Abutting Joint Edges. - The abutting joint edges shall not deviate more than 0.010-inch from the centerline of the beam travel.
- 3.7.3.3 Vertical Mismatch. - Vertical mismatch shall not exceed 0.020-inch prior to seal pass welding.

3.7.3.4 Cleaning. - Prior to and during welding, welded joints, adjacent base metal surface, filler wire, and weld tooling in the area of the welded joint shall be free of all foreign substances.

3.7.3.4.1 Detail Parts. - Detail parts shall be cleaned per MIL-S-5002B. When it is necessary to remove scale, the parts may be pickled per MIL-S-5002B, as applicable, under the cognizance of Materials and Processes Engineering.

3.7.3.4.2 Joint Edge. - Upon completion of cleaning per Paragraph 3.7.3.4.1, joint edges shall be prepared as follows:

- (a) The abutting edge and both surfaces (distance of 1/2 inch width) of each plate or detail shall be cleaned by scraping on aluminum alloys to be welded to remove surface oxides. No filling or wire brushing shall be done after scraping. Titanium and Steel alloy parts shall be chemically cleaned ONLY.

NOTE: All residue remaining from mechanical cleaning shall be removed prior to welding.

- (b) Wipe edges with clean acetone before welding per Paragraph 3.5.4.

NOTE: Handle cleaned parts with clean white nylon gloves. Avoid touching cleaned edges with bare hands.

- (c) Weld parts immediately after cleaning or cover parts with dust cover. Parts not welded within the prescribed time limit shall be recleaned before welding. The time limits are as follows:

- (1) Aluminum alloys - 24 hours
- (2) Titanium alloys - 40 hours
- (3) Steel alloys - 40 hours

Aluminum, titanium and steel alloy parts may be kept under a vacuum or under a positive pressure of dry nitrogen gas per Paragraph 3.5.3(c) or argon gas per Paragraph 3.5.3(b).

3.7.3.4.3 Jigs, Fixtures, Vacuum Chambers and Measuring Devices. - Jigs, fixtures and measuring devices shall be free of scale, grease, protective coatings, oxides, dust, oil or any other substances which may be detrimental to the welding process. Immediately prior to use, all jigs and fixture surfaces which will be in direct contact with parts to be welded, within 12 inches of the weld, shall be wiped with clean acetone per Paragraph 3.5.4 (a).

3.7.4 Production Welding. - Production parts shall be welded in accordance with the parameters established in the certified weld schedule 3.7 and in accordance with the following procedure.

- 3.7.4.1 Preparation. - Material shall be prepared in accordance with 3.7.3 as applicable.
- 3.7.4.2 Seal Welding and Shielding. - Seal welding when required shall be accomplished by using the gas-tungsten-arc (GTA) process and parameters per Table 37 and shielding gases per Paragraph 3.5.3.
- 3.7.4.3 Preheating. - Preheating of steel weldments when required shall be accomplished following Table 38 requirements. Preheating shall be accomplished under vacuum condition.
- 3.7.4.3.1 Temperature Measurement. - Where preheating is specified, temperature measurement shall be determined by thermocouple wires located within 1 inch of the weld seam. Three measurements shall be taken on the top and three measurements taken on the bottom of the weld plate.
- 3.7.4.4 Weld Start and Run-Off Tabs. - Weld start and run-off tabs, when used, shall be of the same alloy as the detail parts and shall be cleaned in the same manner as the detail parts. Such tabs may be attached by gas-tungsten-arc (GTA) welds, when approved by the Cognizant Engineer for electron beam welded structures.
- 3.7.4.5 Full-Penetration Pass. - A full-penetration pass shall be made using the certified weld schedule per Paragraph 3.7 and a welding environment as follows:
- (a) Welding Chamber. - Vacuum pressure at 30 microns or less of mercury.
  - (b) Welding Back-Up Chamber or Fixture/Vacuum Chamber. - Vacuum pressure of 60 microns or less of mercury.
- 3.7.4.6 Cosmetic Pass. - Cosmetic passes for the purpose of correcting unacceptable underfill conditions may be applied at any time after completion of the initial full penetration pass. This cosmetic pass must be certified as outlined in Paragraph 3.7.
- 3.7.4.7 Marking and Identification. - Each weld shall be identifiable with the date and hour of welding, the identification of the welding operator and recorded by Quality Control.
- 3.7.5 Rework. - Rework of imperfections except those listed in Paragraph 3.7.6 may be accomplished by sliding-seal electron-beam welding per certified weld schedules. The reason for the rework, its location and a description of the rework method shall be recorded by Quality Control. A rework weld shall be defined as a full-penetration weld accomplished subsequent to the original full-penetration weld. Restarting of the electron-beam after an arc-out shall not be considered a rework but shall be recorded by Quality Control. Cleaning may be accomplished to ensure a quality weld, using the previous described cleaning methods.

- 3.7.6 Weld Repair. - Where the following conditions exist, repairs shall be accomplished using procedures specified by Materials and Processes Engineering and approved by the Cognizant Engineer for Electron-Beam Welded Structures. The reason for the repair, its precise location and description of the repair procedures shall be recorded by Quality Control. Repairs necessitated by items (a) and (b) below shall be subject to Material Review Board action. If the repair procedures specified below necessitated by conditions (c) and (d) fail to produce a satisfactory weld, a second repair attempt shall be subject to Material Review Board Action.
- (a) The rework will result in gross deformation that will exceed Engineering drawing dimensions.
  - (b) The wrong filler wire was used.
  - (c) Any given location has been reworked three times per Paragraph 3.7.5.
  - (d) A change in heat-treat conditions and then heat-treated to another condition prior to repair.
- 3.7.6.1 Class "A" Welds. - Welding repair of Class "A" welds shall be performed by sliding-seal or hard vacuum chamber electron-beam welding only.
- NOTE: Repair by the Gas-Tungsten-Arc (GTA) or Plasma-Arc Weld (PAW) processes can be used only after written permission and the repair welding procedure has been approved by Materials and Processes Engineering and the Cognizant Engineer for Electron Beam Welded Structures.
- 3.7.6.2 Class "B" Welds. - Where repair using the sliding-seal or hard vacuum chamber electron-beam welding is not feasible, repair of Class "B" welds may be accomplished after the repair welding procedure is approved by Materials and Processes Engineering and the Cognizant Engineer for Electron Beam Welded Structures. Repair may be accomplished by the Gas-Tungsten-Arc (GTA) or Plasma-Arc-Weld (PAW) processes.
- 3.7.6.3 Marking and Identification of Repair Welds. - Repair welds shall be marked so that the identity of the welding operator or operators can be established. Quality Control will designate the type of stamp and other necessary methods to be used to maintain the identity of the repaired weld.

#### 4. QUALITY ASSURANCE PROVISIONS

Quality Control shall be responsible for assuring compliance with the requirements of this specification.

##### 4.1 Certification of Welding Procedure. -

4.1.1 Tests for Welding Procedure Certification. - The following inspections and tests shall be performed for certification of the welding procedure:

- (a) Visual inspection per Paragraph 4.2.1
- (b) Non-destructive inspection per Paragraph 4.2.2
- (c) Destructive tests per Paragraph 4.4

4.1.2 When the specimens do not meet the certification requirements of this specification, a new welding procedure shall be established and additional specimens shall be welded and submitted for certification.

##### 4.2 Post Weld Inspection. -

4.2.1 Visual Inspection. - All weldments shall be visually inspected, up to 15X magnification, for conformance of the following requirements:

4.2.1.1 Dimensions and Location. - Weld size, location, length and configuration shall be within the minimum requirements of the Engineering drawing.

4.2.1.2 Color. - The weld bead and adjacent base metal shall have a color similar to that of the unwelded material. In the case of titanium, especially, this shall be a bright silver or light straw-colored appearance; blue-gray or gray discoloration or the presence of loose scale shall be cause for rejection.

4.2.1.3 Penetration. - Joints shall show evidence of complete (100%) penetration unless otherwise specified on the Engineering drawing.

4.2.1.4 Incomplete Fusion. - Incomplete fusion or missed seams are not acceptable. A minimum of 0.010 inch of material from each side of the seam shall be included in the welded area.

4.2.1.5 Cracks. - Cracks are not acceptable in the weld, heat-affected zone or adjacent base metal. There shall be no evidence of surface or internal cracks.

4.2.1.6 Voids. - Voids open to the surface are not acceptable.

4.2.1.7 Underfill and Concave Root Surface. - The cumulative effects of underfill and concave root surface shall not exceed the post-weld machining allowances as specified on the Engineering drawing. For surfaces which are not machined after welding, the allowable concave root surface and underfill shall be as specified on the Engineering drawing.

- 4.2.1.8 Undercutting. - Undercut in the base-metal is not acceptable in any weld joint wherein the section thickness exceeds the minimum base-metal tolerance. Where possible, undercut and/or root notches should be specified on the Engineering drawing.
- 4.2.1.9 Craters. - Craters may be acceptable provided there is no evidence of cracks in the crater, weld metal or parent metal and the base of the crater does not extend below the base-metal surface.
- 4.2.1.10 Burn-Through. - Burn-throughs are not acceptable in the weld or adjacent base metal.
- 4.2.1.11 Overlaps. - Overlaps are not acceptable.
- 4.2.1.12 Welder's Identification Stamp. - The presence of a welder's identification stamp is required in the vicinity of the weld joint. The welder identification number may be used near the weld joint or part traveler when specified on the Engineering drawing. Another method that may be used is metal impression stamping on the part or part traveler when specifically required on Engineering drawings, or metal impression stamping a metal or plastic tag and attaching same to the welded assembly when subsequent processing, prior to acceptance, would obliterate the marking of the rubber stamp.
- 4.2.2 Non-Destructive Inspection. -
- 4.2.2.1 Radiographic Inspection. - Radiographic inspection in accordance with MIL-STD-453 shall be performed in addition to visual inspection when specified on the Engineering drawing. All weld certification tests, Class "A" welds and not less than 5 percent of the representative non-critical welds (Class "B") shall be selected for inspection. Defects shall be restricted as follows:
- 4.2.2.1.1 Cracks. - The presence of cracks in the weld, heat-affected zone or adjacent base-metal are not acceptable.
- 4.2.2.1.2 Penetration. - Joint penetration shall be 100 percent unless otherwise specified on the Engineering drawing.
- 4.2.2.1.3 Incomplete Fusion. - Incomplete fusion and missed seams are not acceptable. A minimum of 0.010-inch of material from each side of the weld joint shall be included in the welded area.
- 4.2.2.1.4 Overlaps. - Overlaps are not acceptable.
- 4.2.2.1.5 Underfill and Concave Root Surface. - The cumulative effects of underfill and concave root surface shall not exceed the post-weld machining allowances as specified on the Engineering drawing. For surfaces which are not machined after welding, the allowable underfill shall be as specified on the Engineering drawing.

4.2.2.1.6 Porosity, Cavities, Voids and Inclusion. - Weld discontinuities such as porosity, cavities, voids and inclusions (metallic and nonmetallic) occurring at the surface or within the weld metal or immediately adjacent to the base metal shall be determined radiographically and shall be restricted and sized as follows:

- (a) The diameter of internal porosity, cavities, voids and inclusions shall be sized by its largest dimension.
- (b) Inclusions (metallic or non-metallic) and cavities (gas, voids or otherwise) shall be treated the same as porosity.
- (c) Interconnected porosity inclusions and cavities (voids) shall be considered as one single pore for sizing purposes.
- (d) Individual discontinuities shall be separated by a minimum distance equal to three times and four times the largest dimensions of the smaller adjacent discontinuity for aluminum and titanium alloys, respectively.
- (e) Pores and voids identified with the welding operation are acceptable provided they do not exceed the limits set forth in paragraph 4.2.2.2.
- (f) Any group of five or more discontinuities falling on a straight line and within one linear inch of weld (aligned porosity) shall be cause for rejection if the distance between adjacent discontinuities is less than six times the largest dimension of the smaller adjacent discontinuity.

4.2.2.2 Class "A" Welds. - In addition to the final machined requirements of Paragraph 4.2.2.1, Class "A" welds shall conform to the following:

- (a) Maximum Pore Diameter - Maximum pore diameter for the titanium and steel alloys shall not exceed 0.10T or 0.050 inch, whichever is less ("T" is hereafter defined as the final thickness of the weld after all processing). For aluminum alloys, the maximum pore diameter shall not exceed 0.25T or 0.063 inch, whichever is less.
- (b) Maximum Number of Pores - The maximum number of pores in any two inch length of weld along the entire weld length shall not be greater than five for titanium and steel alloys and eight for aluminum alloys.
- (c) Total Defect Area - The sum of the maximum pore dimensions in any two inch length of weld along the entire weld length shall not be greater than 0.100 inch for titanium and steel alloys and 0.150 inch for aluminum alloys for internal pores measured radiographically.

- (d) Defect Spacing - Minimum spacing between discernible pores shall be three times the diameter of the smallest pore for aluminum alloys and four times the diameter of the smallest pore for titanium and steel alloys. However, two or more adjacent discontinuities shall be treated as one individual discontinuity when the spacing between them is less than three times the greatest dimension of the smaller adjacent discontinuity for aluminum alloys and less than four times for titanium and steel alloys; i. e., if a 0.030-inch discontinuity and a 0.020-inch discontinuity are separated by only 0.045-inch measured from the edge of one discontinuity to the edge of the other, the discontinuity would be evaluated as a 0.050-inch diameter discontinuity.
- 4.2.2.3 Class "B" Welds. - In addition to the requirements of 4.2.2.1, Class "B" welds shall conform to the following requirements:
- (a) Maximum Pore Diameter - Maximum pore diameter for titanium or steel alloys shall not exceed 0.2T or 0.060 inch, whichever is less. For aluminum alloys, the maximum pore diameter shall not exceed 0.50T or 0.070 inch, whichever is less.
- (b) Maximum Number of Pores - As specified in Paragraph 4.2.2.2.
- (c) Total Defect Area - As specified in paragraph 4.2.2.2.
- (d) Defect Spacing - As specified in Paragraph 4.2.2.2.
- 4.3 End-Product Inspection. - Post Weld Inspection - All weldments (production and weld schedule certification test plates) shall be inspected for conformance to the following requirements:
- 4.3.1 Visual Inspection. - Welds shall be visually inspected to the requirements of 4.2.1.
- 4.3.2 Non-Destructive Inspection. -
- 4.3.2.1 Radiographic Inspection. - Welds shall be radiographically inspected to the requirements of Paragraph 4.2.2. In addition, radiographic inspection shall be used as the referee technique for sizing, identifying, and positioning indications disclosed by ultrasonic inspection.
- 4.3.2.2 Ultrasonic Inspection. - Welds shall be ultrasonically inspected as a supplement for the detection of missed seams or incomplete fusion. Discontinuities or isolated ultrasonic responses which are reinspected and not shown to be missed seams shall not be cause for rejection. Welds shall be inspected per a company or government specification.
- 4.3.2.3 Penetrant Inspection. - Welds shall be penetrant inspected per MIL-I-6866 to determine those defects open to the surface.

- 4.3.2.4 Magnetic Particle Inspection. - Magnetic particle inspection shall be performed, when specified by the Engineering drawing or when weldments are fabricated from HY 130 and D6AC steel alloys in accordance with MIL-I-6868 as follows:
- (a) Method of magnetization - longitudinal and/or circular.
  - (b) Method of particle application - wet continuous or residual.
  - (c) Type of particle - fluorescent or non-fluorescent.
  - (d) Acceptance criteria - no defects allowed.
- 4.4 Destructive Tests. - Weld Schedule Test Specimen Inspection. - Weld schedule test specimens shall be subject to the following destructive tests.
- 4.4.1 Penetration Weld Joint Inspection. -
- 4.4.1.1 Metallurgical Examination. - Two test specimens from each test plate shall be sectioned transverse to the weld, polished and etched for metallurgical examination. Welds shall be examined as macro-sections at 3 to 10 power magnification. The macro-sections of the weld shall conform to the requirements of Paragraph 4.2.1, 4.2.2 and 4.2 for Class "A" welds. A photograph of a representative cross-section shall accompany the weld schedule when it is forwarded to Materials and Processes Engineering. Minimum weld bead width shall be indicated on the photograph.
- 4.4.1.2 Tensile Strength. - Three test specimens from each test plate shall be tensile tested to failure for determination of strength in accordance with ASTM8. The weld shall be considered satisfactory when tension test failure occurs at a stress equal to or greater than the procurement specification minimum tensile strength for the base metal. Specimens failing at the bond line of the weld or in the weld metal shall be considered satisfactory only when visual (3 to 10 power) examination of the fracture surface reveals it to be free of defects per Paragraph 4.2.
- 4.4.2 Cosmetic Pass Weld Joint Inspection. - One test specimen at least two inches long shall be sectioned longitudinally along the weld bead centerline per Figure 83, polished and etched for metallographic examination. Welds shall be examined as micro-sections at a minimum of 100X magnification and shall meet the acceptance criteria of Paragraphs 4.2.1.2 through 4.2.1.9 and Paragraph 4.2.2 in its entirety. A photograph of the representative cross-section shall accompany the weld schedule which shall be forwarded to Materials and Processing Engineering.
- 4.5 Rejection. - Individual units or lots, as applicable, of welded parts which do not meet the requirements of this specification shall be subject to rejection or MRB action.

4.6 Repair Welding Requiring Materials Review Action. - Defective welds shall have Materials Review action prior to repair if any of the following conditions exist:

- (a) The repair will result in obvious gross deformation that will exceed the Engineering drawing dimensions.
- (b) The wrong filler metal has been used.
- (c) Any given location has been repaired three times.
- (d) Assemblies were originally welded in one heat-treat condition and then heat-treated to another condition prior to repair.

4.7 Repair Weld Inspection. -

4.7.1 Visual Inspection. - All repair welds shall be visually inspected for conformance to Paragraph 4.2.1.

4.7.2 Radiographic Inspection. - All repairs in critical welds (Class A) and not less than three percent of the repairs in non-critical welds (Class B) shall be radiographically inspected per MIL-STD-453 for defects as specified in Paragraph 4.2.2.

4.7.3 Magnetic Particle Inspection. - All repair welds on steel alloys shall be inspected for conformance to paragraph 4.3.2.4.

## 5. NOTES

5.1 Definitions. - All definitions shall be as per MIL-STD-20.

5.2 Safety and Medical Precautions. - Safety precautions, as specified by the Safety Engineer, and medical precautions, as specified by the Medical Department, shall be adhered to.

5.3 Suppliers (Sellers). - This specification shall be applicable for Supplier (Seller) compliance as specified by the Contract, Engineering drawings and specifications. All deviation requests must be submitted in writing, via the Purchasing Department, to the Standard Specification Committee for approval.

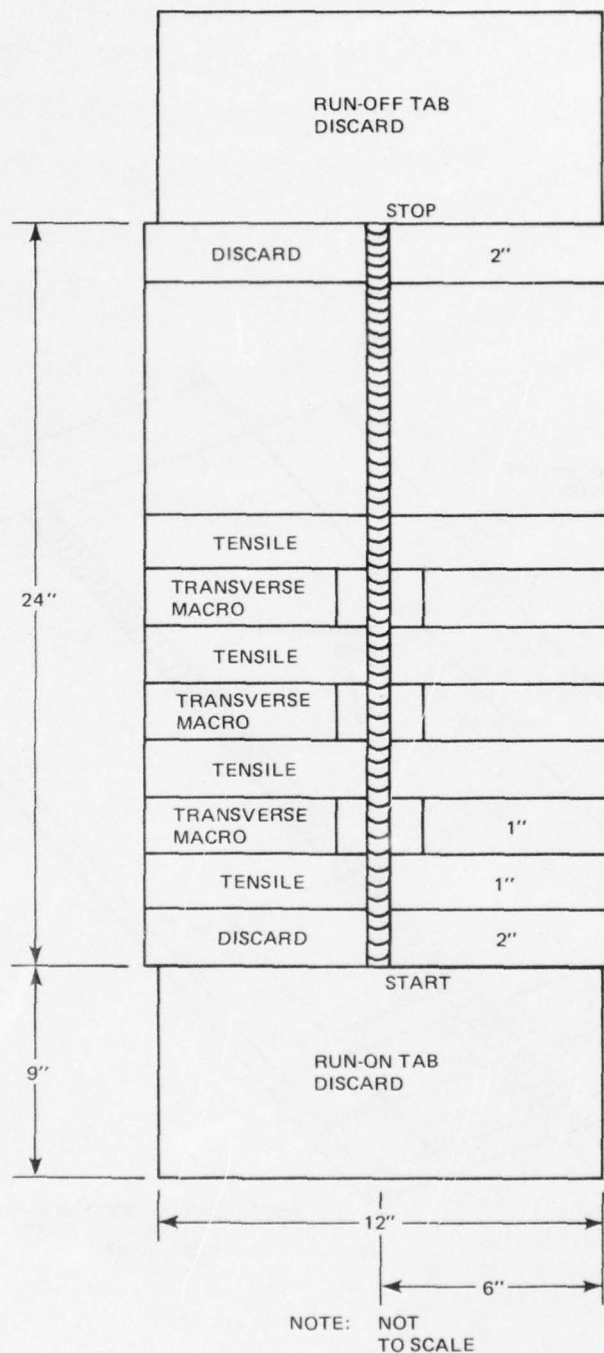

- NOTE (1) Tensile Specimens Shall be Machined Flush to Remove Weld Reinforcement and Penetration
- (2) For Weldments Fixtured Inside a Vacuum Chamber the Plate Dimensions shall be 8" Wide by 24" Long.

Figure 82 Weld Test Specimen

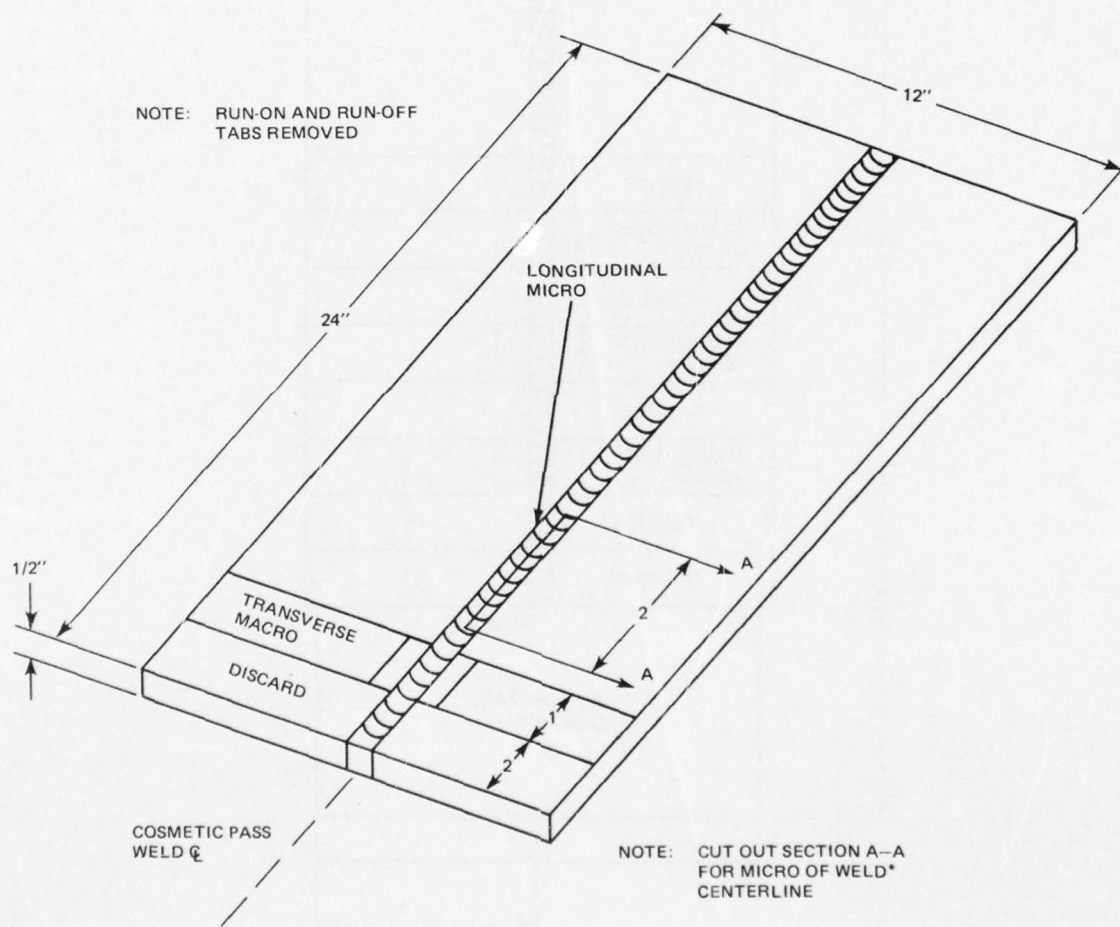

NOTE: For Weldments Fixtured Inside a Vacuum Chamber the Plate Dimensions Shall be 8" Wide by 24" Long

Figure 83 Cosmetic Pass Weld Test Specimen

TABLE 35. TITANIUM, ALUMINUM AND STEEL ALLOYS AND FILLER METALS

| Base Metal <sup>1</sup>                              | Filler Metal <sup>2</sup>                   |
|--|---|
| Ti-6Al-4V Titanium Alloy per MIL-T-9046F or AMS 4911 | Ti-6Al-4V Titanium Alloy per AMS 4956 (ELI) |
| 2014-T651 Aluminum Alloy per AMS 4029E               | 4043 Aluminum Alloy per AMS 4190            |
| HY 130 Steel Alloy per MIL-I-16216G                  | Wire and Rod per MIL-R-5632B.               |
| D6AC Steel Alloy per GM 1013                         | MIL-R-5632B                                 |

<sup>1</sup> Base Metal shall be in the condition specified on the Engineering drawing prior to welding. These base metals may be changed or added to only by the written approval of Materials and Processes Engineering and the cognizant Electron Beam Welding Engineer.

<sup>2</sup> At the discretion of the Materials and Processes Engineer, filler metal may be used as an aid to correct an underfill, undercut or gap conditions in a localized area. These filler metals may be changed or added to only by the written approval of Materials and Processes Engineering and the cognizant Electron Beam Welding Engineer.

TABLE 36. REQUIRED PARAMETERS TO BE RECORDED IN WELDING SCHEDULE

1. Applicable Electron Beam Certification (EBC) Number
2. Base Metal Alloy and Condition
3. Base Metal Thickness
4. Pre-Weld Cleaning Procedure and/or Applicable Cleaning Specification
5. Edge Preparation
6. Filler Metal Type and Specification
7. Filler Metal Diameter
8. Filler Wire Feed Speed ( $\pm 10$  percent)
9. Number and Sequence of Passes
10. Operator
11. Operator I.D. Stamp
12. Materials and Processes Engineer
13. Welding Speed, inches per minute ( $\pm 5$  percent)
14. Sketch of Set-up including all angles ( $\pm 30$  minutes)
15. Filament Used
16. Beam Current ( $\pm 5$  percent)
17. High Voltage ( $\pm 5$  percent)
18. Focusing Current ( $\pm 5$  percent)
19. Cathode to Anode spacer and type
20. Witnessing Inspector's Name and Stamp
21. Quality Control Certification
22. Vacuum Gage Reading in Welding Area: Start \_\_\_\_\_, End \_\_\_\_\_
23. Vacuum Gage Reading in Back-up Table or Weld Fixture/Vacuum Chamber: Start \_\_\_\_\_, End \_\_\_\_\_
24. Energy Input in Kilojoules/Inch ( $\pm 5$  percent)
25. Preheat Temperature

Energy Input is calculated as

$$H = \frac{(KV) \times (Ma) \times 60}{\text{Welding Speed (IPM)} \times 1000}$$

where H = Kilojoules/Inch

KV = High Voltage (Item 17)

Ma = Beam Current (Item 16)

IPM = Welding Speed (Item 13)

TABLE 37. GAS-TUNGSTEN-ARC (GTA) SEAL-WELDING PARAMETERS FOR  
Ti-6Al-4V TITANIUM ALLOY AND 2014-T651  
ALUMINUM ALLOY PLATE MATERIALS

| Material                       | Thickness,<br>Inch | Current,<br>Amps | D. C. Voltage,<br>Volts | Carriage<br>Travel Speed,<br>Inch/Min. | Torch<br>Shielding<br>Gas Flow,<br>Cu. Ft./hr. | Trailing Shield<br>Gas Flow,<br>Cu. Ft./hr. | Back-Up<br>Gas Flow,<br>Cu. Ft./hr. |
|--------------------------------|--------------------|------------------|-------------------------|--|--|---|-------------------------------------|
| Ti-6Al-4V<br>Titanium<br>Alloy | 1/4                | 70               | 15                      | 30                                     | 40   | 180   | 5                                   |
|                                | 1/2                | 85               | 15                      | 30                                     | 40   | 180   | 5                                   |
|                                | 3/4                | 85               | 15                      | 25                                     | 60   | 180   | 5                                   |
|                                | 1                  | 85               | 14                      | 20                                     | 60   | 180   | 5                                   |
| 2014-T651<br>Aluminum<br>Alloy | 1/4                | 150              | 13                      | 30                                     | 40   | —   | 5                                   |
|                                | 1/2                | 150              | 13                      | 15                                     | 40   | —   | 5                                   |
|                                | 3/4                | 150              | 13                      | 10                                     | 60   | —   | 5                                   |
|                                | 1                  | 200              | 15                      | 10                                     | 60   | —   | 5                                   |

TABLE 38. STEEL THERMAL PROCESS REQUIREMENTS

| Base Metal | Weld Process | Filler Wire Per<br>Specification | Preheat<br>Temperatures | Post Heat   | Post Weld<br>Thermal Treatment |
|------------|--------------|----------------------------------|-------------------------|---|--------------------------------|
| HY 130     | SSEB         | MIL-R-5632                       | 150° – 300° F           | 600° to 700° F<br>For 1 Hr. Minimum/<br>in. Thickness | MIL-H-006875E                  |
| D6AC       | SSEB         | MIL-R-5632                       | 350° – 800° F           |   |                                |

## APPENDIX II

### SLIDING-SEAL ELECTRON-BEAM WELDER; EQUIPMENT AND APPLICATION SPECIFICATION FOR

1. SCOPE - This specification establishes the equipment and application requirements for Sliding-Seal Electron-Beam Welders.
2. APPLICABLE DOCUMENTS
  - 2.1 Government Documents. - The following documents (referred to under the basic number in subsequent paragraphs) shall form a part of this specification to the extent specified herein:  
  
MIL-W-80119                      Welding Machines, Electron-Beam, Vacuum Type
  - 2.2 Other Documents. - The following documents shall form a part of this specification to the extent specified herein:  
  
NAS 976                              Electron-Beam Welding Machine - High Vacuum
3. REQUIREMENTS
  - 3.1 SSEB Welder. - A general-purpose, production-type, sliding-seal electron-beam welding system shall contain a boom manipulator providing a six-foot stroke on the X axis and a five-foot stroke on the Z axis. The boom shall be capable of being rotated 360° about the vertical for position. The electron-beam gun and welding chamber shall be mounted at the end of the boom. Provisions shall be made for either down-hand welding with the electron-beam gun vertical, or vertical-up welding with the gun mounted horizontally.
  - 3.2 Size.
    - 3.2.1 The boom manipulator shall be capable of rotating in a 16-1/2-foot radius. The horizontal motion of the boom manipulator shall permit welding for six feet on the X-axis mode.

- 3.2.2 The vertical column of the SSEB shall be capable of raising the boom manipulator by hydraulic and/or mechanical means to permit welding for five feet in the Z axis.
- 3.2.3 A four-foot-square platform shall be mounted on one end of the boom to support the vacuum pumps required for maintaining the vacuum in the electron-beam gun chamber and the lower head assembly. The electron-beam gun chamber and lower head assembly shall be mounted below this platform.
- 3.2.4 The base support of the equipment shall be approximately seven square feet and support the vertical column, high-voltage tank, AVR cabinet, electronic control cabinets and a hydraulic pump. It shall be capable of 360-degree rotation in the horizontal plane.
- 3.3 Electron-Beam Gun.
- 3.3.1 The electron-beam gun shall be a self-accelerated triode type capable of maximum continuous beam power of 30 KW (60kv, 500ma) and shall include all necessary controls to assure repeatability and reliability of its functions. Separate control of beam current and accelerating voltage shall be possible. Automatic control of beam focus shall be maintained regardless of changes in accelerating voltages at any given gun-to-work distance.
- 3.3.2 The electron-beam gun shall be housed in a rectangular chamber mounted at one end of the boom manipulator. The gun shall be hinged to the top of the chamber to provide access to the gun for repair, cleaning and changing of filament and EB gun parts.
- 3.3.3 Power to the EB gun shall be supplied by an external high-voltage cable connected to the top of the EB gun and the high-voltage tank.
- 3.3.4 The electron-beam gun shall be a stationary gun inside the chamber whereby travel shall be maintained for welding by moving the entire boom manipulator/EB gun chamber/head assembly across the work-piece or by moving the workpiece under a stationary EB gun/head assembly.
- 3.3.5 The electron-beam gun chamber shall be provided with an automatic vacuum shut-off valve to isolate the gun from the lower head assembly when this assembly is open to air. This valve shall permit changing of filaments and cleaning the gun without loss of vacuum in the head assembly. This valve shall be interlocked to prevent operation of the gun unless the valve is fully opened and proper operating vacuum levels have been attained in the lower head assembly.

- 3.3.6 The gun chamber shall be "0" ring-sealed to a support plate located between the gun chamber and lower head assembly. This sealing arrangement shall permit movement of the gun chamber  $\pm 1/4$  inch along the Y axis. This arrangement shall be provided for movement of the weld beam to align it with the weld seam.
- 3.4 Sliding-Seal Head Assembly.
- 3.4.1 The lower head assembly shall be mounted beneath the electron-beam gun chamber. Sliding seals located at the bottom of this assembly shall be provided for sealing the head assembly against the workpiece and/or weld fixture. The head plate/sliding seals shall be pinned to the lower head assembly in such a way that the head plate can move  $1/2$  inch up or down when making sealing contact. A flexible bellows assembly shall be "0" ring-sealed between the gun chamber and the head plate to maintain vacuum between the gun and workpiece and/or fixture.
- 3.4.2 The lower head assembly shall be able to be removed from the boom manipulator mounting plate and rotated 90 degrees for changing of welding modes. When the head assembly and seals are aligned with the boom manipulator, the X-axis drive for boom travel shall be operated. The second mode shall require that the lower head assembly be rotated 90 degrees to align the sliding seals with the weld seam and/or fixture. In this mode the boom manipulator shall be held stationary and the workpiece and/or fixture moved under the sliding seals.
- 3.5 Seals.
- 3.5.1 The sliding seals shall be molded from silicone rubber (RTV631) and mechanically fastened to the head plate in an elliptical shape having a major axis of 8 inches and a minor axis of 4 inches. Two sliding seals shall be used to form an inner vacuum in the welding area and an outer guard vacuum to isolate the weld area from rapid changes in vacuum pressure.
- 3.5.2 "0" ring seals referred to in this specification, which are used for fixture, cover plate and seal plate sealing, shall be formed from Buna N, "0" ring cord stock. Thickness and length of these "0" rings shall be dependent upon the particular application used and the "0" ring groove shape.
- 3.5.3 Special shape seals shall be silicone rubber (RTV 631) tee seals molded for sealing tee extrusions which extend the walls of the Special Shapes fixture.

- 3.6 Vacuum. - The vacuum producing system shall consist of all necessary devices to assure rapid pump-down to and holding capability at specified vacuum conditions.
- 3.6.1 The vacuum chamber housing the electron-beam gun shall be capable of maintaining the gun at  $10^{-4}$  torr or better.
- 3.6.2 The lower head assembly/sliding seal unit shall be capable of sealing the workpiece area to a vacuum of 10-50 microns. Weld vacuum shut-off level shall be set for 80 microns.
- 3.6.3 Vacuum requirements for all fixtures require that the pumping system be capable of maintaining a vacuum pressure of 10-50 microns during welding. Helium leak tests shall be performed on all fixtures to locate and suitably seal all vacuum leaks.
- 3.6.4 Vacuum pumps required to maintain the vacuum for the SSEB gun and lower head assembly shall be suitably mounted on the boom manipulator to minimize or eliminate the transmission of vibration to the welding equipment and to provide the shortest vacuum lines to the vacuum chambers.
- 3.6.4.1 All pumping sequences shall be controlled from the operator control station. Operation of each pump shall be individually initiated from the control station. Operation of the pumping sequence for the diffusion pump and gun chamber shall be controlled automatically once the sequence start is initiated.
- 3.6.4.2 An interlock to prevent application of power to the gun when proper vacuum levels have not been established shall be required.
- 3.6.4.3 A 1000 liter/sec diffusion pump and a 15-cfm mechanical pump shall be used to evacuate the gun chamber to desired vacuum pressure.
- 3.6.4.4 A 53-cfm duo-seal mechanical pump shall be used to maintain vacuum in the head/seal area for welding purposes and a 5-cfm pump shall be used for the guard vacuum maintained between the sliding seals.
- 3.6.5 All vacuum pumping operations shall be monitored by appropriate vacuum metering equipment.
- 3.6.5.1 A thermocouple tube and readout gage shall be connected to the gun chamber to automatically control change-over from mechanical to diffusion pump systems.

- 3.6.5.2 A thermocouple tube and readout gage shall be connected to the head/seal assembly to determine vacuum levels in the weld area. This gage shall be interconnected with the vacuum valve located between the gun chamber and head/seal assembly and weld sequencing start switch. A vacuum level of 80 microns must be attained before the vacuum valve will open and the weld sequencing can be initiated. A vacuum rise over 80 microns will automatically shut down welding operations and close the vacuum valve to prevent damage to the gun.
- 3.6.5.3 Additional vacuum tubes and readout meters shall be connected to the head/seal assembly and the weld fixture for operator monitoring of the vacuum pressure. These meters shall monitor vacuum pressure from 0 to 1000 microns and shall be calibrated with the thermocouple tube every six months.
- 3.7 Electrical Controls.
- 3.7.1 Power Supply Unit. - The power supply unit shall provide the necessary power on a 100 percent duty cycle to meet all of the requirements of this specification. The power supply units shall have adequate insulation for the design voltage levels and a suitable enclosure to house the components, meters, and associated control equipment. To facilitate maintenance, a manual lifting mechanism shall be provided to raise the major components out of the enclosure. The power supply unit shall include a line voltage stabilizer capable of stabilizing the input voltage to plus or minus one percent for plus or minus fifteen percent line voltage changes. The stabilizer shall be of the type with a response time of one hundred milliseconds or less, as required.
- 3.7.2 Gun Power Supply. - The line regulation of the gun power supply shall be plus or minus one percent for ten percent line variation. The supply shall have an output ripple of not more than five percent rms, maximum, and shall have an output stability of plus or minus one percent over a one-hour period. The supply shall be equipped with a regulating device to hold the accelerating output voltage to within plus or minus one percent of the set voltage regardless of the beam current used and shall provide flat regulation within plus or minus one percent from no load to full load.
- 3.7.3 Bias Control Power Supply. - The bias control power supply shall deliver the required emission power. As required for critical welding applications, ripple shall be not greater than five percent rms and stability shall be plus or minus five percent over a one-hour period. The current shall be continuously adjustable.

- 3.7.4 Focusing Current Power Supply. - The focusing current power supply shall deliver the required focusing current. Ripple shall be not greater than plus or minus one tenth of one percent of maximum rating, and current stability shall be one tenth of one percent of the maximum rating of the supply over a one-hour period.
- 3.7.5 Slope Control. - The slope control shall provide independent and continuous adjustment of the initial power level, up-slope rate, down-slope rate, and final power level, to minimize weld irregularities at the start and stop of weld beads. Slope control may be accomplished by adjustment of the beam current, beam voltage or power density, as required, to assure consistent and repeatable results. Focus shall be maintained during up-slope and down-slope. Separate direct-reading, lockable dials shall be provided for initial accelerating voltage or current level, final accelerating voltage or current level, and the welding accelerating voltage or current level. The up-slope setting shall control the rate from the initial accelerating level to the weld level. The down-slope setting shall control the rate from the weld level to the final accelerating level. The levels and the slope functions shall be electronically controlled. The initiation and the termination of each function shall be mechanically or manually controlled. Up-slope shall be initiated manually by the weld start switch, and down-slope shall be initiated manually by a spring-return switch. Manual termination shall be accomplished by de-activating the weld switch.
- 3.8 Operator's Controls. - All controls necessary for welding shall be contained on the operator's control station. The control elements on this station shall include:
- (a) Sequence Reset - to reset welding and vacuum system
  - (b) On/off button - separate button to control electrical power
  - (c) Filament indicator light
  - (d) Weld sequence buttons - sequence start and sequence stop
  - (e) Select button for continuous or tack weld mode
  - (f) Filament on/off button
  - (g) Focus current on/off button
  - (h) Manual delay button - manual delay of high voltage

- (i) Mushroom head, red "Emergency Stop" button for arresting welding operation
- (j) Pumping sequence button
- (k) X-axis jog and drive switches; digital speed adjust pot
- (l) Y-axis jog switch for beam alignment
- (m) Z-axis jog and drive switches, digital speed adjust pot
- (n) X-axis table drive select switch
- (o) Bias control on/off switch
- (p) Seam tracking controls, meter and digital adjust pot
- (q) Proximity controls, meter and digital adjust pot
- (r) Focus current adjust pot
- (s) High-voltage controls, jog switch, lock and unlock control switch; and high-voltage pot adjust
- (t) High-voltage on/off button and indicator light
- (u) Table drive control - forward, reverse switch and run/jog switch, and digital pot adjust.

### 3.9

Setup Control Panel. - All controls necessary for welding setup and monitoring shall be incorporated on the setup control panel. The controls and meters shall include:

- (a) Bias controls - beam current meter, beam current digital adjust pt. and beam overload pot
- (b) Mushroom head, red "Emergency Stop" button
- (c) High-voltage meter
- (d) Filament adjust control dial

- (e) Timers - digital adjust pots. for weld, slope, high-voltage start delay and travel start delay
- (f) High-voltage switch to control, operate and set up equipment.

3.10 Mechanical Controls. - All drives either hydraulic ball screw or gearing devices and all driving motors shall be located as close as possible to the driven mechanism. Movement shall be at fixed and variable rates of speed and shall be within  $\pm .001$  inch per foot divergence. Variable speed rates shall be controllable from 5 to 100 inches per minute. Safety limit switches shall be provided to shut off power to the drive motors when end of travel is reached.

3.10.1 Boom manipulator and/or fixture motion shall be straight within .001 inch per foot and shall not exceed .010 inch in any 10 feet of travel.

3.10.2 Jogging switches for initial positioning of the boom manipulator and/or weld fixture shall be provided.

3.10.3 An accessory unit independent of SSEBW requirements, the flat plate weld and slot weld vacuum chambers, shall provide setup and welding of parts utilizing a stationary SSEB gun and moving part and/or vacuum box. These units shall be moved by a motor-driven rack and pinion setup capable of maintaining accurate travel speeds from 20 to 80 inches per minute travel. The 35-foot-long rails for these units shall be level to within .003 inch tolerance for the 35-foot length.

3.10.4 Travel speeds for all welding modes (X axis, Z axis, flat plate and vacuum chamber movement) shall be calibrated with the system set up for welding and vacuum sealing of the head/seal assembly completed.

#### 4. UTILITIES

4.1 Utilities. - The welder shall be designed and constructed to utilize the following:

4.2 Electrical Power. - 480 volts  $\pm 10\%$ , 3-phase, 60 HZ.

4.3 Water. - 35 psig

4.4 Air. - 90 psig

Exhaust (from 140 cfm vacuum pump), 2-inch line.

5. WELDING FIXTURES

- 5.1 Welding Fixtures. - This section describes the welding fixtures fabricated for special welding application, requirements for vacuum and welding and operational use of the SSEB equipment in conjunction with the fixture.
- 5.2 Flat Plate Welding Fixture. - This fixture shall be designed for making weldments up to 15 feet in length on flat plate. Long flat plates shall be aligned, clamped and vacuum sealed to a weld fixture supported on roadway supports on a rail/table set up. The weld plate and fixture shall be traversed under a stationary SSEB weld head positioned on the weld seam.
- 5.2.1 Fixture Dimensions. - The fixture shall be three feet wide, one foot high and 17 feet long and mounted on 35-foot-long rail guides supported by two 15-foot tables.
- 5.2.2 Travel. - Travel motion shall be attained by a rack and pinion/chain driven system coupled to a 2-hp D.C. motor and gear box reducer assembly. Travel speeds shall be maintained from 0 to 100 ipm, with a speed range of 20 to 80 ipm calibrated to insure accuracy and repeatable under welding conditions. Travel speeds shall be calibrated in both forward and reverse travel directions. All travel speeds shall be controlled by a digital pot. on the operator console station. A separate jog switch shall be used for initial alignment of the weld fixture. Maximum travel length attained by this fixture is 13-1/2 feet.
- 5.2.3 Weld Materials. - The materials weldable on this fixture shall be 2014-T651 aluminum alloy plate and Ti-6Al-4V titanium alloy plate.
- 5.2.4 Vacuum. - Vacuum sealing of the SSEB head assembly shall be maintained by sliding seals riding on the weld plate. Vacuum sealing of the weld plate to the weld fixture shall be maintained by two "0" ring seals and a TIG seal-pass weld.
- 5.2.4.1 Sealing. - Vacuum sealing of the head assembly shall be held by a 55-cfm mechanical pump located on the boom manipulator. Vacuum for the weld plate/fixture sealing shall be held by 140-cfm mechanical pump connected by a manifold system to the weld fixture. A separate 7.5 cfm vacuum pump shall be used to hold a 'guard' vacuum between the two "0" ring seals on the fixture.

AD-A031 901

GRUMMAN AEROSPACE CORP BETHPAGE N Y  
SLIDING-SEAL ELECTRON-BEAM WELDING. (U)  
JAN 76 H P ELLISON, R H WITT

F/G 13/8

UNCLASSIFIED

AFML-TR-76-3

F33615-73-C-5030

NL

3 of 3

AD  
A031901



END

DATE  
FILMED  
1 - 77

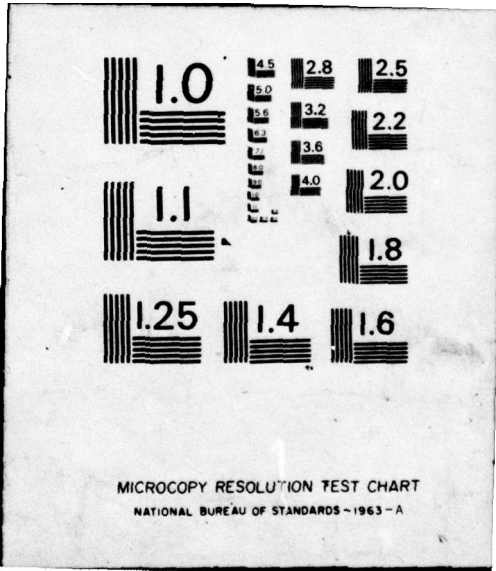

- 5.2.4.2 Manifold System. - The manifold system shall consist of four one-inch-I. D. Tygon tubes supported by a powertrak assembly and connected to rigid copper tubing adapted to the weld fixture.
- 5.2.4.3 GTA Seal Pass. - A light fusion weld pass shall be made on the weld plate surface and completely around the end tube to provide vacuum sealing for the weld plate to the weld fixture.
- 5.2.4.4 Vacuum Levels. - Vacuum levels in the head assembly/sliding seals shall be held at 20 to 30 microns for aluminum welding and 50 to 60 microns for titanium welding. Fixture backup vacuum level shall be 10-15 microns prior to start of welding. The vacuum rise shall not exceed 150 microns for aluminum plate welding and 200 microns for welding of titanium plate.
- 5.2.5 Weld Seam Alignment. - Banking blocks shall be provided on the weld fixture to insure proper alignment of the weld plate. After the GTA seal-pass shall have been made on the weld seam, the center of the weld seam shall be scribed along the GTA weld. The head assembly shall be positioned on the weld seam and spot tacks welds shall be made at several intervals to check weld seam alignment. Jogging of the boom shall be possible to correct misseam alignment. Accurate weld seam alignment shall be assured by travel motion of the weld fixture on the rails.
- 5.2.6 SSEB Welding. - SSEB welding shall be performed by moving the workpiece (weld plate) beneath a stationary sliding seal/head assembly. Acceptable weldments in aluminum and titanium plate can be made provided that the requirements for this specification and the SSEB welding specification are followed.
- 5.2.7 Tooling Tolerances. - Hold-down bars, clamps and pushers (Allen screws for lateral plate pressure) shall prevent the weld plate from moving or buckling during welding operation. Adequate clearance for the head assembly on the weld plate (6-inch clearance on both sides of the weld seam) shall be made for the welding operation.
- 5.3 Special Shapes Welding Fixture. - This fixture shall be designed for making a two-pass weldment on aluminum and titanium tee sections. Tee sections which extend through the walls of the fixture shall be welded by positioning the sliding seal/head assembly over a slot on the fixture cover and moving the weld head assembly. The tee sections shall be positioned in rotating supports for the top weld operation and then rotated 90 degrees for the second welding operation.

- 5.3.1 Fixture Dimensions. - The fixture is a 12x12x10-inch box with two six-inch holes in opposite ends. Round inserts shall be used for workpiece tooling (clamping and aligning) and accommodate the vacuum seals and "O" ring seals. A 4-inch view port shall be provided for weld observation. The fixture shall be fabricated from 1/2-inch-thick hot-rolled steel and the view port from 1/4-inch-thick leaded glass to prevent radiation leakage from the fixture. The round insert parts shall be machined from one-inch-thick aluminum plate.
- 5.3.2 Travel. - The length of travel for welding in this fixture shall be limited to 3 1/2 inches (length of slot in cover plate). Since the welded tee sections were 3 inches wide by 3 inches high, a 3 1/2-inch slot was required to use run-on and run-off tabs for welding.
- 5.3.3 Weld Materials. - The fixture shall be used to weld 0.300-inch-thick tee sections in 2014-T651 aluminum alloy and Ti-6Al-4V titanium alloy materials.
- 5.3.4 Vacuum. - Vacuum sealing of the fixture shall be maintained by proper positioning of the head/sliding seals on the cover plate supported by an "O" ring on the cover plate and by special molded seals in the round inserts. The lead glass viewing port and the top cover plate shall be "O" ring-sealed to the fixture.
- 5.3.4.1 Special Shape Seals. - The special molded seals shall be injection molded from RTV 631 silicone rubber using tee sections and round insert blocks. They shall be triangular in shape and seal around the tee sections where they protrude through the round insert blocks.
- 5.3.4.2 Vacuum Level. - The vacuum level attained in the weld fixture shall be 10-15 microns held by a 7.5-cfm mechanical vacuum pump. A slight increase in vacuum level of 5 microns will be noted during the short welding operation. Vacuum level in the fixture and sliding-seal area shall be balanced by the 1/2-inch-diameter orifice hole in the seal plate.
- 5.3.5 Weld Seam Alignment. - Weld seam alignment shall be maintained by proper positioning of the fixture and cover plate set up on the work table. This shall align the X-axis drive of the boom manipulator with the slot and weld seam. Part alignment inside the fixture shall be maintained by banking the tee section against two angles bolted to the base of the fixture. The part shall be fixtured and supported by the round insert block and adjustable roller guides mounted inside the fixture. Weld beam alignment to the weld seam

shall be checked by spot tack-welding both ends of the weld seam. Cross-seam adjustment of the weld beam shall be made by jogging the EB gun chamber (Y axis) accordingly.

- 5.3.6 SSEB Welding. - SSEB welding shall be performed by sliding the head assembly over the slot in the cover plate. The weld beam shall travel through the slot and weld the part. The part shall be first fixtured to weld the top cross member of the tee section, vacuum shall be released, the fixture opened, the cover removed and the round roller guides and round insert blocks loosened so that the part can be easily rotated 90 degrees. The tee section shall then be clamped securely, the cover replaced on the fixture and the head assembly aligned for the second weld on the vertical leg of the tee which shall be set in the horizontal plane.
- 5.4 Preheat Steel Weld Fixture. - This fixture shall be designed with heating elements incorporated into the support assembly so that high-strength alloy steel can be preheated and/or post-heated after welding. This fixture shall consist of a steel vacuum chamber which contains support clamping assembly and heating elements in conjunction with a slotted aluminum cover plate "O" ring sealed to the fixture. A seal plate shall ride on a second "O" ring and the sliding seal/head assembly vacuum sealed to the seal plate. Temperature control and regulation for material heatup shall be maintained and recorded by thermocouples and Variac power control.
- 5.4.1 Fixture Dimensions. - The fixture shall be a 54x30x8 1/2-inch box with a slotted (30-inch slot) aluminum cover plate, in which two 24-inch-long heating elements shall be encased within two 2x2x24-inch support bars which shall be used for material support and clamping.
- 5.4.2 Travel. - The maximum weld travel length for this fixture shall be 30 inches, the length of the slot in the cover plate.
- 5.4.3 Weld Materials. - This fixture shall be used for welding one-inch-thick HY 130 and D6AC alloy steel plate.
- 5.4.4 Vacuum. - The vacuum level attained in this welding fixture shall be 15-20 microns held by a 140-cfm mechanical vacuum pump. A vacuum rise to 50-60 microns will be noticed during the SSEB welding operation. Vacuum capability shall be unaffected by the pre-heating operation.

- 5.4.5 Preheat Set Up. - Two Watlow Firerod heating elements of 208-volt/2400 watt capacity shall be used to preheat materials before welding.
- 5.4.5.1 Electrical. - A 220-volt/60-ampere single-phase line service shall be the required power input to an adjustable-output Variac - D. C. power supply. The heating elements shall be wired in series or parallel to the Variac depending upon the preheat time/temperature requirements. Two Veeco vacuum-sealed, insulated feed-through connections shall be used to feed the electrical supply from the Variac through the chamber walls to the heating elements.
- 5.4.5.2 Preheating. - Time and temperature of preheating for welding shall be predetermined from test runs and material requirements. Heat-up rates and temperature control shall be varied by changing from parallel to series connection and by changing the control setting on the power supply. Control/regulator shall be used up to 600<sup>o</sup>F temperatures.
- 5.4.5.2.1 Preheating - Postheating. - All preheating and postheating shall be accomplished in accordance with the appropriate military specification.
- 5.4.5.3 Temperature Recording. - Temperature recording for the power supply shall be monitored by a control thermocouple. A strip chart/temperature recorder shall also be used to record temperatures of the weld plate at various locations. Ten thermocouple wires shall be available for temperature monitoring.
- 5.4.6 Weld Seam Alignment. - Weld alignment shall be maintained by proper positioning of the fixture and cover plate set up on the work table. This shall align the X-axis drive of the boom manipulator with the slot and weld seam. Part alignment on the support bars shall be determined by angle slips that are used for banking the weld plate while fixturing. Hold-down bars and pushers (threaded bolts) shall rigidly clamp and prevent movement of the workpiece. Weld beam alignment to the weld seam shall be checked by spot tack-welding both ends of the weld seam. Cross-seam adjustment of the weld beam shall be made by jogging the EB gun chamber (Y-axis) accordingly.
- 5.4.7 SSEB Welding. - Slot welding shall be used on the preheat steel welding fixture. The five-foot aluminum seal plate shall be positioned on an "O" ring on the cover plate. The electron-beam shall pass through the orifice hole and strike the workpiece making the

required weld. Vacuum shall be attained in the fixture and preheating of the weld plate to the desired temperature shall be performed before welding operations. The welded plate shall be held under vacuum condition until its temperature is slow cooled to a present level.

- 5.5 Cylinder Weld Fixture. - This fixture shall be designed to support, align, vacuum seal and rotate a 12-foot-diameter, 1/2-inch-thick aluminum cylinder for SSEB welding around its circumference.
- 5.5.1 Fixture Dimensions. - The fixture shall consist of a base support ring 148 inches in diameter welded to a six-foot-diameter base plate by eight "I" beam support arms. Eight stanchions (20 inches high) shall be bolted to the base support ring which position and support a 143-inch-diameter steel back up/vacuum seal ring. This steel ring shall fixture, support and align the aluminum cylinder which rests on the base support ring. Inflatable "O" ring seals bonded to the steel back up/vacuum ring shall be used to form the vacuum seal required for EB welding. A special, 13x9-inch curved head plate machined to a 6-foot radius shall be used to shape the sliding seals for vacuum sealing a cylinder.
- 5.5.2 Travel. - The travel length for the cylinder weld shall be 37 1/2 feet (circumference of a 12-foot-diameter cylinder). An Aronson Positioner which rotates the cylinder shall be capable of forward and reverse travel with variable rotation or linear travel speeds. The travel speed used for GTA seal-pass welding shall be 15 ipm and SSEB weld travel speed shall be 40 ipm.
- 5.5.3 Weld Material. - The cylinder welded on the fixture shall be fabricated from 2024-T351 aluminum alloy plate.
- 5.5.4 Vacuum Levels. - The vacuum levels attained for welding the cylinder shall be 10 microns in the sliding seal/head assembly and 150 microns in the backup weld area of the weld seam.
- 5.5.4.1 Vacuum Sealing of Head. - Vacuum sealing of the sliding seal/head assembly shall be similar to previous pumping operation except that the sliding seals shall be formed to a six feet radius of curvature and shall be precisely positioned for sealing against the cylinder.

- 5.5.4.2 Vacuum Sealing of Backup Area. - Vacuum sealing of the backup area of the weld seam shall be maintained by special means. Inflatable "0" ring seals shall be used to form the vacuum "walls" between the cylinder and steel backup ring. Four, one-inch-diameter steel tubes shall connect the ring to a centrally located vacuum port. A swivel (flexible ball joint) vacuum fitting mounted in the base of the fixture shall be connected to a tee fitting. Flexible vacuum hoses shall connect two vacuum pumps to the tee fitting. Two vacuum pumps, a 140-cfm mechanical pump and a 53 duo-seal vacuum pump, shall be used to maintain a 150-micron vacuum level in the backup weld area.
- 5.5.4.3 GTA Seal Pass. - A light fusion weld pass shall be required to seal the outside circumference of cylinder for vacuum sealing of the cylinder to the backup ring.
- 5.5.4.4 Inflatable Seals. - B. F. Goodrich - Type D inflatable seals shall be used to vacuum seal the cylinder.
- 5.5.4.4.1 Installation of Seals. - Two grooves shall be machined into the steel ring. The "0" ring seals shall be bonded to the fixture.
- 5.5.4.4.2 Tolerances. - Inflation of the seals against the inside surface of the cylinder shall allow for  $\pm 1/4$  inch tolerance in sizing of the cylinder.
- 5.5.5 Equipment Setup for Cylinder Weld. - The SSEB gun chamber and sliding seal/head assembly shall be remounted on the boom in the vertical mode. The sliding seal/head assembly shall be rotated 90 degrees to boom travel direction to align the seals in the direction of the horizontal weld seam.
- 5.5.5.1 Sliding-Seal Head Plate. - A curved head shall be used on the head assembly in order to form the seals to the proper radius of curvature. This plate shall be machined to a six-foot radius.
- 5.5.5.2 Cylinder Setup. - The cylinder shall be set on the base support fixture and positioned by jack screws located in the back vacuum ring. Sizing of the cylinder to outside dimension shall be held to  $\pm 1/8$  inch tolerance.
- 5.5.5.3 Fixture Setup on Positioner. - The fixture and cylinder shall be positioned on an Aronson DH-50 Positioner. The fixture shall be centered on an alignment pin and bolted in place for turning. The positioner shall then be levelled (weld seam of cylinder shall be optically levelled).

- 5.5.6 SSEB Welding. - Welding of the cylinder shall be accomplished by positioning the curved sliding seals against the outside wall of the cylinder and rotating the cylinder during welding. Alignment of the weld beam to the weld seam shall be checked by spot tack-welds made on the GTA seal-pass weld. Positioning of the EB gun shall be changed by raising or lowering the boom/manipulator on the equipment Z-axis. Positioning of the beam assembly/sliding seals against the cylinder shall be controlled by a limit switch which allows the head assembly/sliding seals to move in or out (1/4 inch) while maintaining proper vacuum sealing for welding.

6. WELDER CERTIFICATION

- 6.1 SSEB welding equipment shall conform to Specification NAS976 or other appropriate military or company specification, and shall be capable of producing welds meeting the requirements of Quality Assurance.
- 6.2 A Performance Verification test shall be performed on the SSEB welding equipment in order to insure equipment operating capabilities. This test shall be performed on installation of equipment operating capabilities. This test shall be performed on installation of equipment and every six months thereafter.
- 6.3 Electron-beam certification weldments shall be made and inspected by Quality Assurance to certify weld configuration, position, fixture and operators.

7. SAFETY

- 7.1 Each machine shall be furnished with adequate safety devices of the latest approved type. Moving parts which are hazardous to personnel shall be suitably protected. All equipment and components shall comply with applicable "Occupational Safety and Health Standard, Part 1910 of Chapter XVII of Title 29 of the Code of Federal Regulations (Occupational Safety & Health Act (OSHA) - 1970)," and the state and local safety codes where equipment is to be installed.
- 7.2 Ample protection against electrical shock shall be provided.
- 7.3 All electrical systems shall, insofar as possible, be designed for fail-safe operation and shall be properly isolated, shielded, and grounded for operating safety.

7.4 No radiation levels shall exist which, if an individual is consistently present in the area, could result in his receiving a dose in excess of .25 millirem in any one hour, or if an individual is consistently present in the area, could result in his receiving a dose in excess of 100 millirems in any seven consecutive days.

7.5 Safety limit switches shall be provided to shut off power to the gun and/or work carriage when maximum travel is reached.

8. MAINTENANCE

8.1 All preventative maintenance and repair maintenance procedures shall be carried out in accordance with the manufacturer's recommendations. Weekly and monthly preventative maintenance schedules are listed in the manufacturer's Maintenance Manual supplied with the SSEB welding equipment.

## SECTION VI

### REFERENCES

1. Johnson, Carlis, "Moving Electron-Beam Welding Systems," Final Report to Air Force Materials Laboratory, Sciaky Bros., Inc., Technical Report AFML-TR-69-82, May 1969.
2. Witt, R. H., Maciora, J. G., and Ellison, H. P., "Sliding Seal Electron Beam Welding of Aerospace Structures," Final Report to Air Force Materials Laboratory, Grumman Aerospace Corporation, Technical Report AFML-TR-72-287, January 1973.