

AD-A032 126

CONSTRUCTION ENGINEERING RESEARCH LAB (ARMY) CHAMPAI--ETC F/G 18/6
FIBER OPTIC COMMUNICATIONS LINK PERFORMANCE IN EMP AND INTENSE --ETC(U)
OCT 76 R G MCCORMACK, D C SIEBER

UNCLASSIFIED

CERL-IR-E-94

NL

[OF]

AD
A032126



END

DATE

FILMED

1-77

construction
engineering
research
laboratory

12

INTERIM REPORT E-94
October 1976
EMI Circumvention by Fiber Optic Transmission

AD A 032126

FIBER OPTIC COMMUNICATIONS LINK
PERFORMANCE IN EMP AND INTENSE
LIGHT TRANSIENT ENVIRONMENTS

by
Ray G. McCormack
David C. Sieber

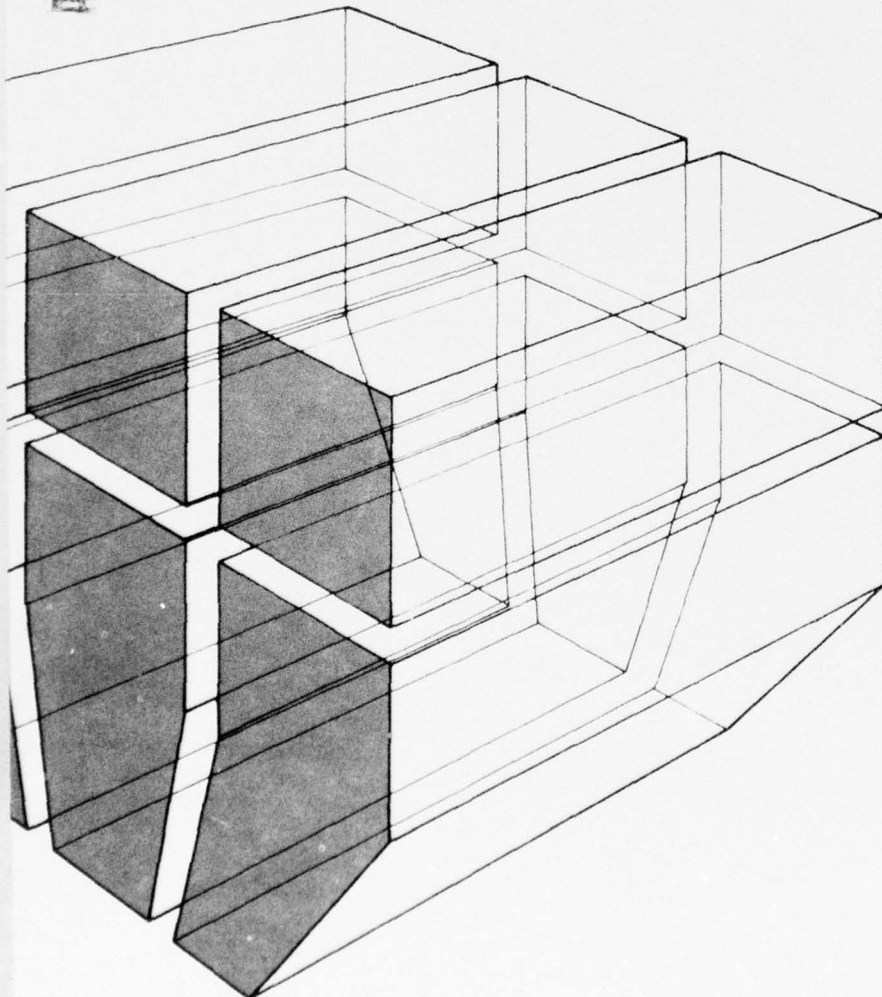

DDC
RECEIVED
NOV 17 1976
B



The contents of this report are not to be used for advertising, publication, or promotional purposes. Citation of trade names does not constitute an official indorsement or approval of the use of such commercial products. The findings of this report are not to be construed as an official Department of the Army position, unless so designated by other authorized documents.

*DESTROY THIS REPORT WHEN IT IS NO LONGER NEEDED
DO NOT RETURN IT TO THE ORIGINATOR*

UNCLASSIFIED

SECURITY CLASSIFICATION OF THIS PAGE (When Data Entered)

REPORT DOCUMENTATION PAGE		READ INSTRUCTIONS BEFORE COMPLETING FORM
1. REPORT NUMBER 14 CERL-IR-E-94	2. GOVT ACCESSION NO.	3. RECIPIENT'S CATALOG NUMBER
4. TITLE (and Subtitle) 6 FIBER OPTIC COMMUNICATIONS LINK PERFORMANCE IN EMP AND INTENSE LIGHT TRANSIENT ENVIRONMENTS	5. TYPE OF REPORT & PERIOD COVERED D INTERIM REPORT	6. PERFORMING ORG. REPORT NUMBER
		8. CONTRACT OR GRANT NUMBER(s)
7. AUTHOR(s) 10 Ray G. McCormack David C. Sieber	9. PERFORMING ORGANIZATION NAME AND ADDRESS CONSTRUCTION ENGINEERING RESEARCH LABORATORY P.O. Box 4005 Champaign, IL 61820	10. PROGRAM ELEMENT, PROJECT, TASK AREA & WORK UNIT NUMBERS 16 4A762719AT40-A1-022 17
11. CONTROLLING OFFICE NAME AND ADDRESS	12. REPORT DATE 11 October 1976	13. NUMBER OF PAGES 22 (12) 24p.
	14. MONITORING AGENCY NAME & ADDRESS (if different from Controlling Office)	15. SECURITY CLASS. (of this report) Unclassified
16. DISTRIBUTION STATEMENT (of this Report) Approved for public release; distribution unlimited.		15a. DECLASSIFICATION/DOWNGRADING SCHEDULE
17. DISTRIBUTION STATEMENT (of the abstract entered in Block 20, if different from Report)		
18. SUPPLEMENTARY NOTES Copies are obtainable from National Technical Information Service Springfield, VA 22151		
19. KEY WORDS (Continue on reverse side if necessary and identify by block number) optical fiber communications links electromagnetic pulse data transmission systems		
20. ABSTRACT (Continue on reverse side if necessary and identify by block number) Optical fiber communications links are a possible means for providing voice and data transmission electromagnetic pulse (EMP) hardened facilities. This report describes evaluations of the effects of high-level EMP fields and intense light flashes on fiber links. The results show that neither EMP fields nor light transients have any appreciable effect on the fiber links. Further evaluations, which were performed in EMP fields to compare the data transmission system using an optical fiber with an equivalent system using conventional cabling, showed the conventional system is susceptible to EMP. The optical link is thus superior in the EMP environment.		

405 279

FOREWORD

This research was conducted for the Directorate of Military Construction, Office of the Chief of Engineers (OCE), under Project 4A762719AT40, "Mobility, Soils, and Weapons Effects"; Technical Area A1, "Weapons Effects and Protective Structures"; Work Unit 022, "EMI Circumvention by Fiber Optic Transmission." The applicable QCR is 1.03.010. The study was conducted by the Electrical-Mechanical Branch (EPM), Energy and Power Division (EP), U.S. Army Construction Engineering Research Laboratory (CERL), Champaign, IL. The OCE Technical Monitor was Mr. H. H. McCauley, DAEN-MCE-D, and the CERL Principal Investigator was Mr. R. G. McCormack.

Appreciation is expressed to W. Croissant, T. Chu, and D. Leverenz of CERL for their contributions.

Mr. R. G. Donaghy is Chief of EP, and Mr. M. J. Pollock is Chief of EPM. COL J. E. Hays is Commander and Director of CERL, and Dr. L. R. Shaffer is Deputy Director.

ACCESSION FOR		
NTIS	White Section	<input checked="" type="checkbox"/>
DOC	Buff Section	<input type="checkbox"/>
UNANNOUNCES		<input type="checkbox"/>
JUSTIFICATION		
BY		
DISTRIBUTION AVAILABILITY CODES		
Dist.	AVAIL.	SPECIAL
A		

CONTENTS

DD FORM 1473	1
FOREWORD	3
LIST OF TABLES AND FIGURES	5
1 INTRODUCTION	7
Background	
Objective	
Approach	
Scope	
Fiber Optics Technology	
2 EXPERIMENTAL SYSTEM DESCRIPTION	8
Basic System	
Modified System	
3 EMP-INDUCED BIT ERROR TEST	10
Test Method and Objective	
Test Setup for Injected Current EMP Tests	
Test Results	
4 HIGH-INTENSITY LIGHT EXPOSURE TEST	15
Test Method and Objective	
Test Results	
5 HIGH-INTENSITY ELECTRIC FIELD EXPOSURE TEST	17
Test Method and Objective	
Test Results	
6 CONCLUSIONS	22
REFERENCES	22
DISTRIBUTION	

TABLES

Number	Page
1 Summary of Pulse Test Results	12

FIGURES

1 Basic System Block Diagram	9
2 NRZ Data and Synchronization Bits in Word Format	10
3 Injected Current EMP Test Setup	11
4 Typical Injected Current Pulse	12
5 Transmitter and Optical Fiber Leading into Conduit	13
6 Coaxial Cable Test Setup Showing Transmitter	13
7 Coaxial Cable Test Setup Showing Cable Entry into Shielded Enclosure	13
8 EMP Effects on Untwisted Pair	14
9 Test Setup for Light Flash Tests	16
10 Photodetector Amplifier Output for Direct Exposure to Flash	17
11 Test Setup for EMP Effect Test	18
12 Typical Pulse from E-Field Sensor for Simulator EMP Measurement	19
13 Optical Fiber Orientations for Light Flash Tests	20
14 Band-Pass Filter	21
15 Six Consecutive Traces from Photodetector Amplifier During EMP Subjection	21
16 Multiple Trace Photo for Parallel Fiber Orientation	21
17 Multiple Trace Photo for Perpendicular Fiber Orientation	22
18 Multiple Trace Photo for Zig-Zag Fiber Orientation	22

FIBER OPTIC COMMUNICATIONS LINK PERFORMANCE IN EMP AND INTENSE LIGHT TRANSIENT ENVIRONMENTS

1 INTRODUCTION

Background

When a nuclear device is detonated, it generates intense electromagnetic radiation in the form of a single pulse with short rise and fall times. The spectral energy that results ranges from the low frequency band through the ultra-high frequency band. The electric and magnetic field intensities associated with the burst are extremely intense, with E-fields exceeding 100 000 V/m (91,440 V/yd).^{*} These intense fields pose hazards to sensitive electronic circuitry because metallic circuit elements such as wires and printed circuit conductors pick up energy. In addition, ground currents induced by the nuclear electromagnetic pulse (EMP) take the path of least resistance through buried metal conduits. These conduits often connect facilities, which, if they are EMP hardened facilities, have steel liner plates. EMP-induced voltage differentials between the facilities then cause additional currents to flow on the interconnecting conduits. If the conduits provide routing for signal and power cabling having metallic conductors, currents may be induced on the conductors.

In large weapons control facilities, such as SAFE-GUARD facilities, the conduit and wiring and cabling networks are large and complex. The EMP pick-up from many different elements may combine at a given point with phasing that produces a very high magnitude current pulse. This pulse can cause damage to electrical or electronic instruments, monitor and control components, and communications and other equipment. Thus, protection against EMP damage to the weapon system must be provided.

One means of providing such protection is through use of optical fibers in signal-carrying lines. Because the fibers are electrically nonconductive and therefore do not carry induced currents, their use would circumvent most of the EMP threat. Further, the fiber can easily be routed through shielding liner

plates without compromising their shielding integrity.

Objective

The overall purpose of this study is to derive information for use in designing weapons control facilities and other types of facilities where EMP and/or electromagnetic interference (EMI) threaten critical communications. The information will ultimately be incorporated into Corps of Engineers guide specifications and Technical Manual (TM) 5-855-5.¹ Specific goals addressed in this report are to:

- a. Compare the performance of a system having an optical data transmission link with that of the same system using conventional twisted pair or coaxial cable as the transmission medium
- b. Determine the effects of high ambient light levels on the optical fiber itself and on its interfacing with the transmitting and receiving components
- c. Establish a bound on the signal-to-noise ratio to be anticipated when the EMP pulse occurs.

Approach

Two types of systems were tested in the laboratory. The first was a complete digital communications link designed to transmit over either an optical fiber or conventional cabling. The second type of system was a modification of the first, which used a constant light level transmitter. In addition, filtering was used in the second system to reduce the noise on the output signal and increase the signal measurement range. Both systems used multimode glass fibers of 500 dB/km (800 dB/mi) attenuation manufactured by the Galileo Electro-Optics Corporation. Chapter 2 describes the systems in more detail.

The first system was tested with the optical fiber in a conduit sample having a loose union at its center. An EMP current pulse of approximately 200 A peak was injected into the conduit. The EMP rise time was less than 10 nsec. At the loose union, an intense EMP field leaked into the interior of the conduit and illuminated the fiber. The number of errors made by the overall system was observed.

^{*}Measurements are given in both English and SI units. The value given first is the unit the measurement was actually taken in; the value in parentheses is the equivalent in the unit of the other system.

¹Nuclear Electromagnetic Pulse (NEMP) Protection, TM 5-855-5 (Department of the Army, 1974).

For comparison, the same digital system was tested using a coaxial cable, a twisted pair of wires, and an untwisted pair of wires in the conduit as the transmission media.

The second type of system was tested in two ways. First, while the fiber was transmitting a constant light level, it was subjected to an EMP field with peak magnitude in excess of 1 400 000 V/m (1,280,160 V/yd). The receiving system was then monitored for any variation in received light level due to the EMP field. The system measurement range was 80 dB.

In the second test, the optical fiber and its end fittings were subjected to an intense light flash from a commercially available electronic strobe flash unit. The light intensity was limited to that generated by the unit at a 1-ft (0.3 m) range. The receiver output was monitored for a disturbance in received light level. The measurement range was 87 dB.

Scope

This study was not intended to investigate the mechanism of interactions between the EMP and data transmission lines, or to analyze the exact way in which the EMP caused an error. Consequently, no attempt was made to quantitatively extrapolate the severity of interference that a threat EMP would cause on any conductors exhibiting susceptibility to EMP in the tests.

Fiber Optics Technology

In recent years both government agencies and industry have devoted extensive efforts to developing optical fibers and electronic interfacing for use as communications links. The heart of such a system is the optical fiber which is used to pass light from one point to another. The output from a light source at the transmitting end of the fiber is optically coupled into the fiber. To convey information across the fiber, the light source is modulated, generally digitally, since nonlinearities cause problems in transmitting analog signals. The most commonly used light sources are light-emitting diodes (LEDs). Use of lasers is limited due to their higher cost and greater modulation difficulties. Semiconductor lasers are not widely used due to their relatively short life span.

At the receiving end of the fiber, a photodetector converts the light energy to an electrical signal which is then demodulated and/or decommutated by con-

ventional electronic systems. The most commonly used photodetectors are solid state photodiodes or phototransistors. If greater sensitivity is required in the detector, a photomultiplier tube can be used.

In previous research, the U.S. Army Construction Engineering Research Laboratory (CERL) developed a fiber optics communications link for feasibility studies. This system has previously been subjected to intense EMP fields to show that it is possible to transmit error-free in an EMP environment. Thus, for practical purposes, the fiber optics link is immune to EMP.

2 EXPERIMENTAL SYSTEM DESCRIPTION

Basic System

General

The experimentation was performed on the system developed by CERL in previous studies. Figure 1 is a block diagram of the basic system, which consists of transmitting and receiving portions. Communication between the transmitter and receiver can be accomplished through either an optical fiber or conventional cables, such as a coaxial cable or a differential pair of wires. Simple switching is provided to facilitate selection of the transmission medium.

Analog Signal Source

The transmitter portion can accept either an external analog signal or an internally generated, repetitive, modified sawtooth waveform. It can also accept either eight-bit parallel or serial digital input signals, but these options were not used in this study.

Analog Signal Sampling

The selected analog signal is sampled in an analog to digital (A/D) converter. Each analog sample is then converted to an eight-bit digital sequence. The A/D converter can thus distinguish 2^8 or 256 levels. The sampling rate of 1.79 MHz is derived from a 3.58 MHz crystal oscillator.

The eight-bit digital sequences from the A/D converter are encoded into a serial bit train which includes the eight data bits, six parity-checking bits, and two synchronization bits. Thus, a total of 16 bits (making up a word) are transmitted for each sample taken by the A/D converter. With the 1.79 MHz bit

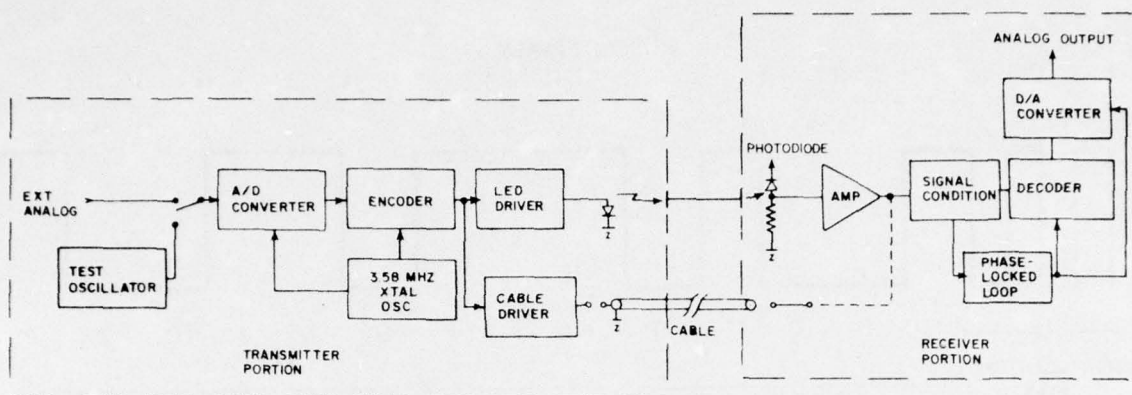

Figure 1. Basic system block diagram.

rate, the sampling rate thus becomes approximately 112 kHz. The analog bandwidth capability is therefore 56 kHz, or one-half the sampling rate, in accordance with sampling theory.²

Error Correction Encoding

The (14,8) binary code provides an error correction capability. It can correct two errors per word; the errors can be adjacent.

Synchronization

Word synchronization is accomplished using the two synchronization bits included with each word. The synchronization bits are of the return to zero (RZ) type, whereas the word's other bits are all the nonreturn to zero (NRZ) type. Figure 2 shows examples of NRZ data and the RZ synchronization bits. The synchronization bits are each one cycle of a square wave, starting at the high or "one" level during the first half of the bit time and returning to the "zero" level during the second half of the bit time. The 14 data and error-correcting bits are represented by a "one" level (high) or a "zero" level (low) for the entire bit duration. Pattern recognition logic circuits in the receiver portion recognize the synchronization bits to establish a timing reference for detecting each data and parity-checking bit in its proper time slot.

Bit synchronization is accomplished using a phase-locked loop within the receiver portion. Within the transmitter, the bit rate is controlled from a

crystal oscillator; thus, the bit rate remains close to the design value. The phase-locked loop therefore requires only a small lock-in and tracking range. This is provided by an integrated circuit which contains a voltage controlled oscillator (VCO), a phase comparator, and a feedback amplifier and filter. The phase comparator derives a voltage which depends on the phase difference between the incoming digital signal bit rate and the VCO. This voltage then changes the VCO frequency and phase until an exact phase relationship (phase lock) occurs.

Since the incoming data are primarily of the NRZ type and have transitions only at the end of a bit interval (if the bit polarity changes), no spectral energy is present at the bit rate frequency. Circuits are thus provided to modify the spectrum of the signal for application to the phase-locked loop. This is accomplished by a series of inverters and an Exclusive OR circuit. The series of inverters creates a fixed time delay. The time-delayed signal is then compared with the original signal in the Exclusive OR circuit. The result is a positive pulse (of fixed width equal to the time delay of the inverters) for each transition of the incoming data. The signal thus produced has spectral power density at the bit rate frequency and allows for satisfactory phase-locked loop operation.

Optical Link

The optical link consists of the optical fiber, the light source, and the light-sensitive detector. Two optical fibers of the same type were used—one 20 ft (6.1 m) long and one 60 ft (18.3 m) long. The longer fiber was required for EMP field exposure testing

²H. S. Black, *Modulation Theory* (Van Nostrand Co., Inc., 1953), Chapter 4.

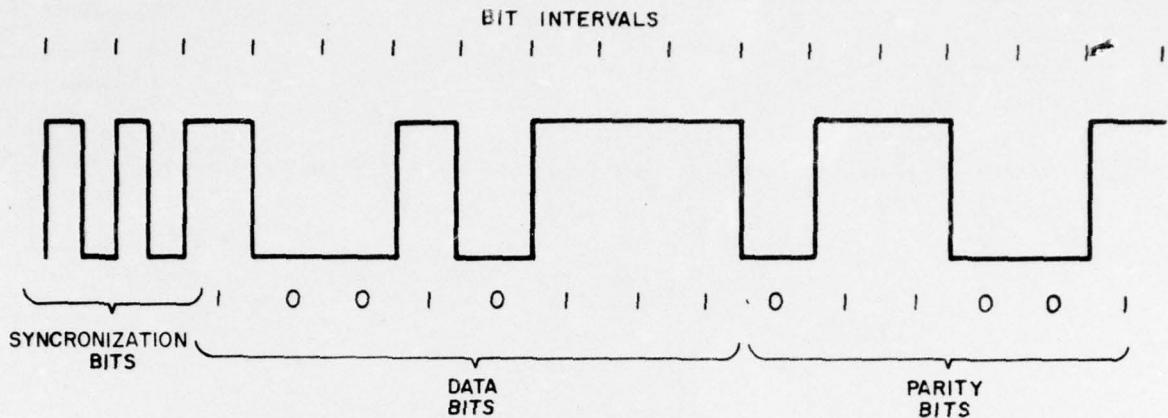

Figure 2. NRZ data and synchronization bits in word format.

due to test setup dimensions. Both optical fibers were manufactured by Galileo Electro-Optics Corporation as number 045A2K. They were multimode, had 500 dB/km (800 dB/mi) attenuation, and were polyvinyl chloride (PVC) jacketed. The black PVC jacketing is designed to protect the fibers and prevent ambient light from causing unwanted signals. The cost for small quantities of the fiber is \$.75/ft (\$2.13/m). The fibers were fitted with standard brass couplings at each end for mating with the LED and photodiode detector.

The light source was a Texas Instruments TIL 31 high-power infrared LED. The TIL-31 is capable of a maximum light output of 6 mW, with rise and fall time capability of 10 nsec. A bandwidth capability of about 30 MHz is thus available; this is more than adequate for the 1.79 MHz bit rate.

To provide maximum light output, the LED requires approximately 200 mA of current drive, which is provided by the LED driver circuit within the receiver. Light detection is accomplished by an avalanche photodiode (Texas Instruments Company type TIXL56) having its response matched to the LED output. The photodiode output is amplified by a wideband amplifier made up from an integrated circuit operational amplifier.

Decoding and Digital to Analog Conversion

The decoder accepts the reconstructed data signal (from the input inverters following the photodiode amplifier) and bit and word synchronization pulses and performs parity checking; if errors are present, they are corrected to the extent possible. The reconstructed data bits are then synchronized in a shift

register to provide reconstructed words which are then sequenced through a second shift register with an eight-bit parallel output. This output is either directly available or available from a resistive ladder network which converts the digital input to an analog output. This digital to analog (D/A) conversion thus reconstructs the original analog signal applied to the transmitter portion of the system, and the link is complete.

Modified System

For the ambient light pickup and EMP pickup tests, the system was modified to use only an LED driver, the LED, the optical fiber, the photodiode, and the wideband amplifier. The modification was necessary to allow measuring only those variations of a fixed level that were caused by the applied disturbances. In addition, filtering was used to reduce the noise on the output signal and increase the signal measurement range.

3 EMP-INDUCED BIT ERROR TESTS

Test Method and Objective

The EMP-induced bit error tests were performed to evaluate the susceptibility of the fiber optic system to EMP and to compare its performance with that of a system using conventional metallic transmission lines. The primary emphasis of this testing phase was to evaluate the susceptibility of the data transmission system to signals which leak through couplings or unions into conduits carrying data transmission lines. However, because it was felt that additional information could be obtained by evaluating

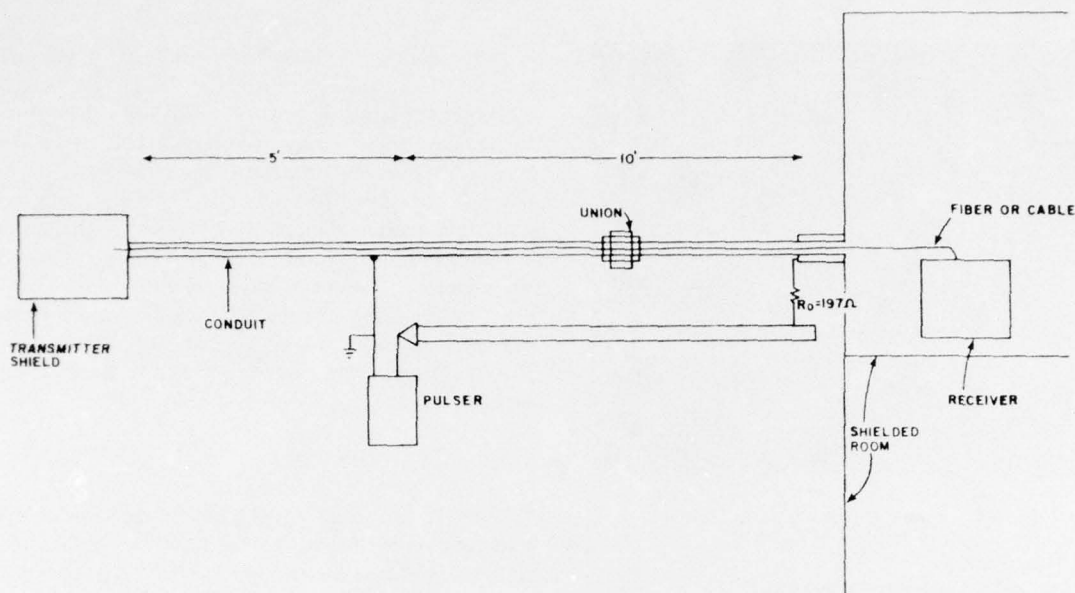

Figure 3. Injected current EMP test setup.

the effect of continuous wave (CW) irradiation, the testing program also included direct CW irradiation of the union.

The approach used in both the injected EMP current and radiated CW evaluations was to install the optical fiber or cable to be evaluated in one conduit of a parallel conduit transmission line. The communications link was then interfaced with the fiber or cable, and data were transmitted. The interfering energy was applied, and the receiver system monitored to determine the number of errors which occurred.

Test Setup for Injected Current EMP Tests

The injected current EMP test setup was similar to the basic system described in the previous chapter. Figure 3 is a schematic of the test setup. Essentially, it consisted of the data transmission system, its shield, and a pulser to inject the EMP.

As previously described, the data transmission system consisted of a transmitter, data transmission line, and receiver. The shield included the box for the transmitter, the conduit through which the data transmission line passed, and the shielded room for the receiver and other electronic equipment. The pulser consisted of a 0.02- μF capacitor (C_0), 0-50 kV

DC power supply, and a sulfur hexafluoride (SF_6) pressurized, adjustable spark gap used to set the firing voltage (V_0). The conduit containing the data transmission line formed the ground side of a parallel conduit transmission line, which was terminated in a resistance (R_0) very near its characteristic impedance.

The rise time of the applied pulse was less than 10 nsec. The fall time (τ_0) was

$$\tau_0 = R_0 C_0$$

so that the pulse (I_τ) was essentially of the form

$$I_\tau = I_0 e^{-t/\tau_0}$$

where

$$I_{(0)} = \frac{V_0}{R_0}$$

and

$$\tau_0 = R_0 C_0$$

For the present case, $V_0 = 30,000$ V, $R_0 = 197$ ohms, and $C_0 = .02$ μF . Thus, the pulse used for these tests had a 150-amp peak current and a fall time of 4 μsec :

$$I_\tau = 150 e^{-t/4 \mu\text{sec}} \text{ A.}$$

Figure 4 shows a typical pulse.

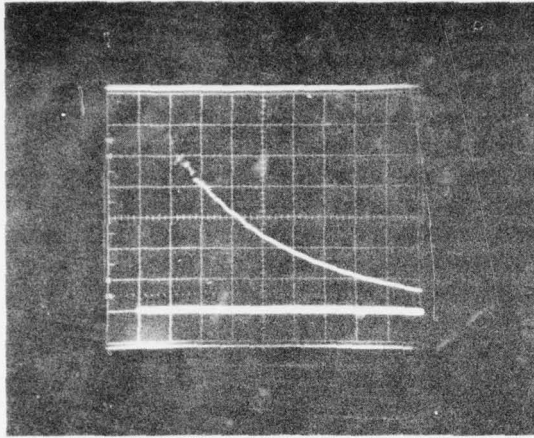

Figure 4. Typical injected current pulse.

$$I(t) = 150 e^{-t/4 \text{ sec}} \text{ A}$$

Scale: 25 A/vertical division
1 μ sec/horizontal division

Although the applied current pulse is well characterized, the electromagnetic fields which leak into the conduit are not easily determined; they depend largely on the condition of the union which joins the two conduit sections. Care was taken to insure that the condition of the union remained the same so that the results of the various tests could be compared.

During the test, the pulser was free running and injected a pulse every 6 to 10 sec. Errors produced in the data were determined by counting the error correction pulses from the decoder in the receiver. The pulses injected during the test were counted on a Beckman Model 7360 Universal EPUT and Timer.

Four types of data transmission lines were tested:

- a. An untwisted pair of no. 22 wires about 20 ft (6.1 m) long, with a short piece of coaxial cable clipped at each end*
- b. A twisted pair of no. 22 wires (with about 19 turns/ft) about 20 ft (6.1 m) long with a short piece of coaxial cable clipped at each end*
- c. A length of coaxial cable (RG 58/U) about 20 ft (6.1 m) long
- d. The optical fiber described previously.

*The short coaxial cable pieces were used to enable shielding of each conduit end and contact between the shielding material and the coaxial cable's outer shield.

In the case of the metallic conductors, it was felt that interference with transmission might be caused by direct superposition of the EMP onto the transmitted data signal or by its being carried along the line into the shielded enclosures and onto the electronic equipment. To study the EMP effect on the data transmission alone, a BNC barrel was placed in the line at each end, and the conduit end was packed with steel wool which contacted the barrel and conduit. For comparison, the tests were repeated without the steel wool packing. Figures 5, 6, and 7 show the conduit end and transmitter and receiver shield boxes.

Test Setup for CW Tests

The CW test setup was essentially the same as the pulse test setup, except that the union was irradiated rather than being subjected to an injected current.

The union was twice irradiated in the 200 kHz to 100 MHz range using loop antennas: once with the plane of the antenna parallel to the conduit and once with it perpendicular to the conduit. The union was also irradiated at 2.5 GHz using a horn antenna.

Test Results

Table 1 summarizes the test results for all four data transmission lines.

Untwisted Pair of Wires

The results validated the assumption that the untwisted pair of wires was the worst case of the four data transmission lines (463 errors produced by 600 pulses [errors/pulse = .772]). Figures 8a and b show

Table 1
Summary of Pulse Test Results

Test Item	No. Pulses	No. Errors	Errors/Pulse*
Untwisted Pair of Wires	600 (500)**	463 (966)	.772 (1.932)
Twisted Pair of Wires	1100 (500)	19 (776)	.017 (1.552)
Coaxial Cable	1000 (500)	0 (454)	.000 (.908)
Optical Fiber	1500	0	.000

*Average number of errors per pulse. In reality, some pulses produced no errors while others produced several.

**Numbers in parentheses are results obtained with steel wool packing removed. (The optical fiber was not packed with steel wool.)

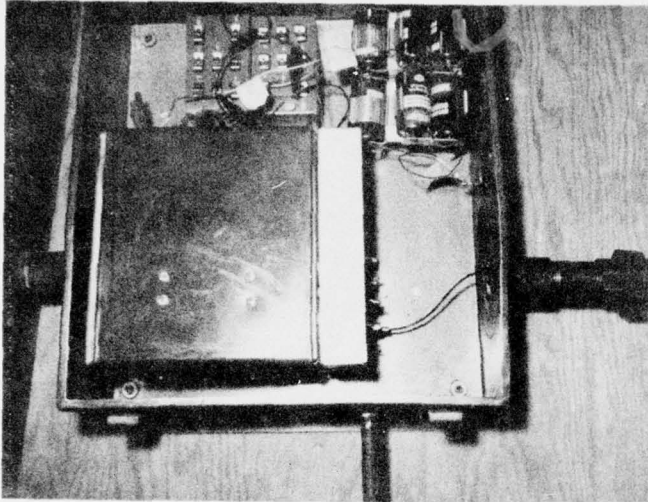

Figure 5. Transmitter (left) and optical fiber leading into conduit (right).

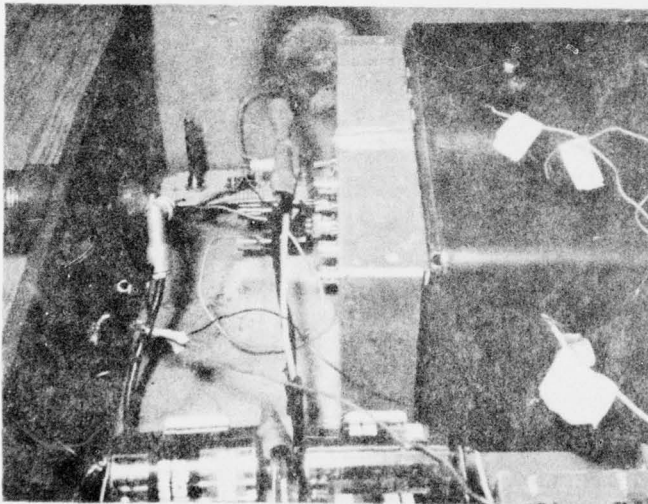

Figure 6. Coaxial cable test setup showing transmitter on the right. Transmitter output is attenuated by the potentiometer at center.

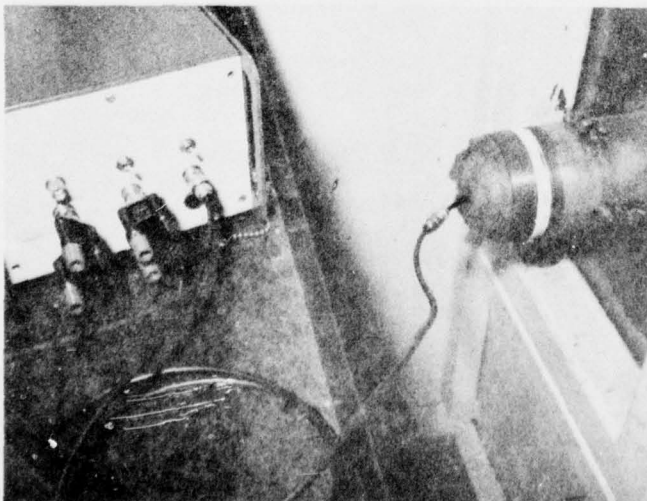
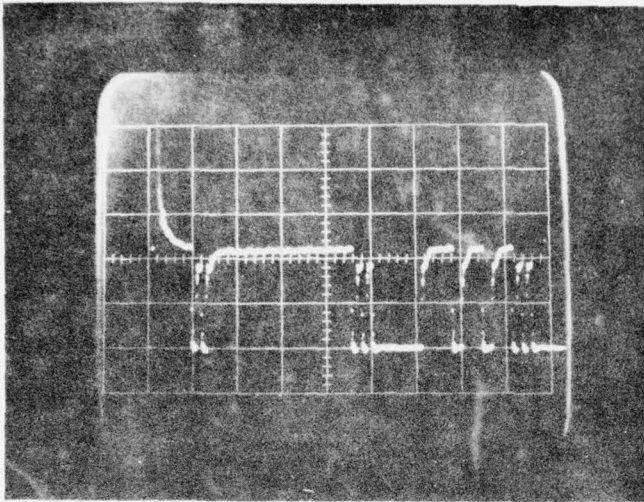
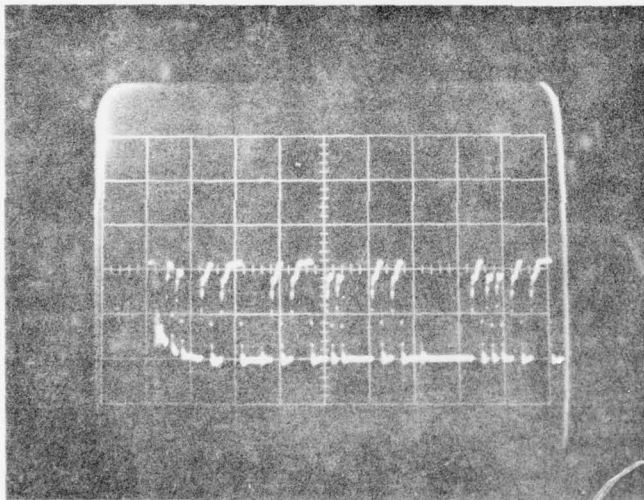

Figure 7. Coaxial cable test setup showing cable entry into shielded enclosure. Note the steel wool packing.



a. Note exponential EMP at left. This pulse produced no error.



b. Note the displacement upward at left.

Figure 8. EMP effects on untwisted pair.

the EMP signal induced on the pair of wires. Due to the additive exponential pulse, the system with untwisted pair of wires may make errors in the detection process.

The CW tests conducted with the loose union produced no errors. In general, no errors were produced even with the union open (i.e., the two sections of the conduit were not connected) except at CW frequencies of 31 mHz, 65 mHz, and 100 mHz. These errors appeared to be due to a resonance (antenna) effect, since the wavelength at 65 mHz roughly corresponded to the length of the conduit and data transmission line. The CW tests at 2.5 GHz produced no errors.

In view of the lack of CW-induced errors on the

worst case—the untwisted pair—under the normal test setup (with the union loosely connecting the two conduit sections), no CW tests were performed on the other data transmission lines.

Twisted Pair of Wires

The 19 errors produced by the twisted pair of wires in 1100 pulses indicates that it is significantly less susceptible to EMP than the untwisted pair; however, it is by no means error-free.

Coaxial Cable

With no errors produced in 1000 pulses, the coaxial cable appears to possess the least susceptibility to EMP of any of the three metallic conductors.

Removal of Steel Wool Packing

Since EMP could also affect data transmission if it were carried along the data transmission line and onto electronic equipment, the steel wool packing was removed from the ends of the conduit, and the test was repeated. Under this test condition, 454 errors were produced by the coaxial cable in 500 pulses. Table 1 also presents data for the pairs of wires with the steel wool removed.

Optical Fiber

The optical fiber data transmission line produced no errors during 1516 pulses.

4 HIGH-INTENSITY LIGHT EXPOSURE TEST

Test Method and Objective

The purpose of the high-intensity light exposure test was to determine whether exposure to a high-intensity flash of light induces any measurable signal on an optical fiber jacketed with black PVC designed to prevent such unwanted signals. The approach used was to establish a fiber optic link with the fiber transmitting a constant light level; the detection system provided a voltage output which depended on the light level transmitted. The fiber was then subjected to an intense flash of light and the detector output monitored for indicated variations in received light levels.

Figure 9 is a block diagram of the test setup. The modified fiber optic link system described in Chapter 2 was used in the testing; it consisted of an LED driver, LED, optical fiber, photodiode, and broadband amplifier. The LED driver consisted of a DC power supply and a resistor. The current through the diode was adjusted to provide near maximum output from the LED.

The optical fiber was placed inside a specially constructed 24 in. × 12 in. × 18 in. (61 cm × 30 cm × 46 cm) flash cabinet for subjection to intense light flashes. The cabinet included a mounting for an electronic strobe flash unit and had small holes for entrance and exit of the fiber. The cabinet was lined with aluminum foil to reflect the light and to help insure even exposure of all possible surfaces of the fiber. The cabinet was made light-tight using foil stripping and aluminum foil tape.

The flash unit used—a Yashica Model PRO-50 DX—had a flash energy of 1100 beam candlepower-seconds (guide number of 33 for an ASA film speed of 25). The flash duration was measured by exposing the open end of the fiber to a flash and observing the resultant pulse on the oscilloscope. Figure 10 shows an oscilloscope photograph of the pulse, which indicated just over 2 msec flash duration or slightly under 1/500 of a second. Because an electric field is generated when the flash is fired, the flash unit was placed outside the shielded enclosure to prevent radiation signals from causing erroneous indications.

To trigger the oscilloscope when the flash fired, a trigger loop was made by wrapping a no. 22 wire around the flash unit 20 times. The loop was then connected to a 50-ohm coaxial cable and a feed-through connector into the shielded enclosure.

The optical fiber was run from the LED, through the flash cabinet, to the photodiode inside the enclosure; 10 ft (3 m) of the fiber were placed inside the flash cabinet. A constant DC level of 5 V was applied to the LED driver with a resultant constant light level transmitted through the optical fiber. The oscilloscope was operated in the AC-coupled, externally triggered mode to allow observation of the signal. Two operators were used—one operated the flash unit outside the shielded enclosure and the other operated the oscilloscope and camera inside the shielded enclosure.

An evaluation of the test setup showed that the amplifier's high frequency noise amplitude was about 50 mV; filtering was therefore necessary. Since any signal due to the flash would be of the same duration and general waveform as the flash itself, the filter was designed to pass a 2-msec pulse and to reject high and low frequency noise.

Filtering was accomplished by a General Radio 1952 Universal Band Pass Filter set for a pass band of 500 to 3000 Hz. This filter is an active filter operated from 115 Vac. The 60-Hz component found on its output necessitated adding an additional filter to further attenuate low frequencies. The noise level after filtering was reduced to approximately 0.2-mV peak to peak. The signal level for the system was about 5 V on the output, giving a range of

$$20 \log \frac{V \text{ signal}}{V \text{ noise}} = 87.9 \text{ dB}$$

That is, it was possible to determine whether the

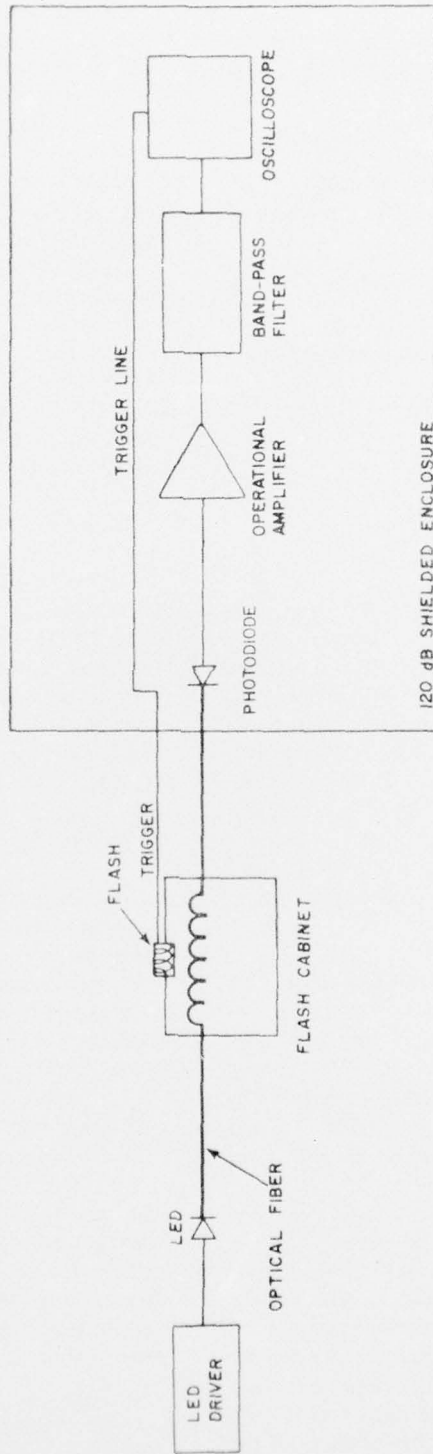

Figure 9. Test setup for light flash tests.

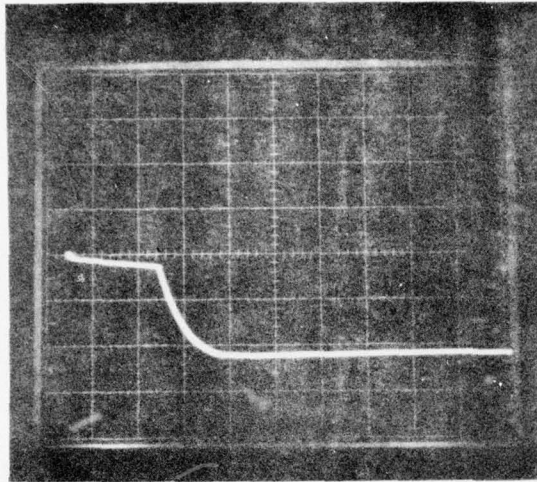

Figure 10. Photodetector amplifier output for direct exposure to flash.
Scale: 5 V/vertical division
1 msec/horizontal division

flash would cause a signal-to-noise ratio of less than 87.9 dB. The overall response of the filter to the expected pulse was checked by "illuminating" the fiber end by the flash and observing the overall output. This resulted in a signal similar to the flash response curve, indicating that the filter did pass the flash signal and would pass any signal resulting from light leakage through the fiber jacket.

Test Results

None of the oscilloscope traces indicated any disturbance due to exposure to the flash of light. Five photographs were taken to insure repeatability. Additional experimentation performed to show the effect of exposure of the fiber couplings to the light flash also showed no measurable disturbance of the transmitted light level. Additional experimentation with zero light level transmitted by the fiber (i.e., with the LED driver off) also resulted in no detectable signal; thus, the black PVC jacketing insured at least an 87.9 dB signal-to-noise ratio during the transient.

5 HIGH-INTENSITY ELECTRIC FIELD EXPOSURE TEST

Test Method and Objective

The purpose of the high-intensity electric field exposure test was to determine the effect of a high-

intensity electric field on an optical fiber. The approach used was to set up a fiber optic link transmitting a fixed (i.e., nonvarying) light level, subject the optical fiber to an intense EMP field, and measure variations in the transmitted light due to the field exposure.

Figure 11 is a block diagram of the test setup. The fiber optic link used was the same as that used in the high-intensity light exposure test.

The CERL Coaxial Electro-Magnetic Pulse Simulator (CEMPS) was used to generate the EMP. The CEMPS is a rectangular coaxial transmission line consisting of a frame structure with an outer wire mesh at ground potential, and a flat plane center conductor. The separation between the central plane and the outer conductor is 1 m (1.1 yd). The central conductor is connected through a tapered section to a 150,000-V spark gap pulser. With the pulser operating at 150 kV, electric fields greater than 150 kV/m (137 kV/yd) can be generated within the simulator.

To generate the required electric field intensity of 1 000 000 V/m (914.400 V/yd), an extra plate was placed inside the CEMPS parallel to the plane of the center conductor and connected to the outer conductor. The support for the added plate was constructed so that its height could be varied, thus allowing control of the separation between the added plate and the center conductor, which in turn controls field intensity.

Care had to be taken that the separation was not too small, thus causing the air to break down and arcing to occur. Since breakdown for air is approximately 23.6 kV/cm (59.9 kV/in.) for an intensity of 1 000 000 V/m (914.400 V/yd), a plate separation of 42.4 cm (16.7 in.) would normally be required. Due to the short duration of the pulse, however, using a plate separation of only 10 cm (3.9 in.) was possible.

To determine the electric field intensity versus pulser voltage, electric field measurements were made with an electric field sensor. Measurements were made at low pulser voltages, and a multiplying factor determined. The sensor was not used with high voltage because of possible arcing between plates and sensor. The multiplying factor determined was 12 V/m (11 V/yd) per volt from the pulser. Therefore the pulser could be operated at 120 kV to generate an electric field intensity of 1.44 MV/m (1.3 MV/yd) between the plates; this pulser voltage was used in the testing. Figure 12 is a trace of

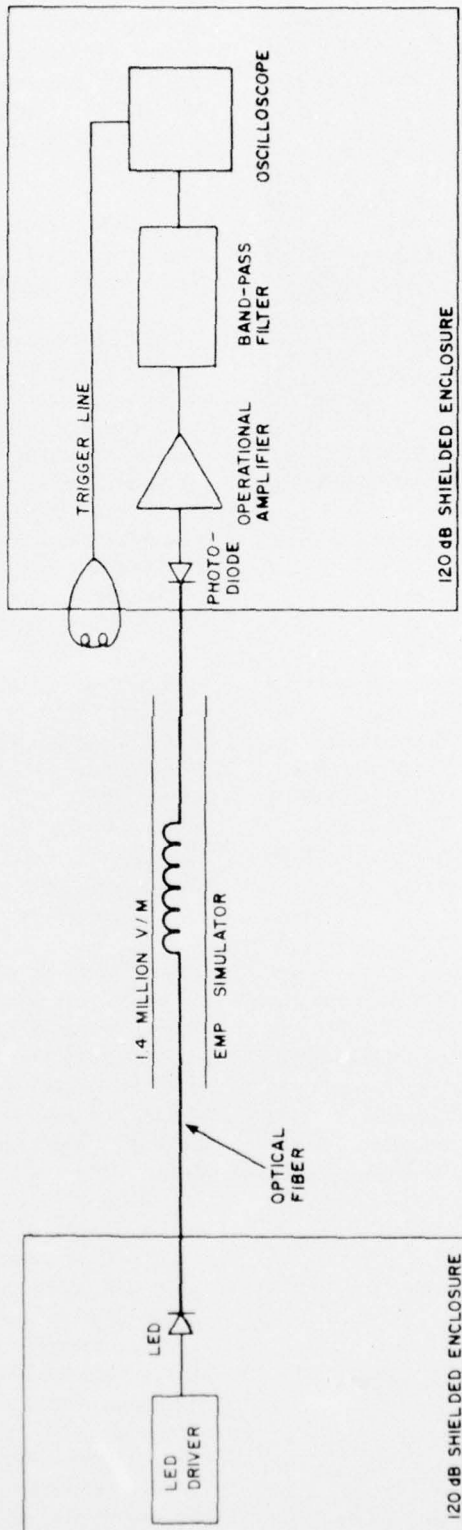

Figure 11. Test setup for EMP effect test.

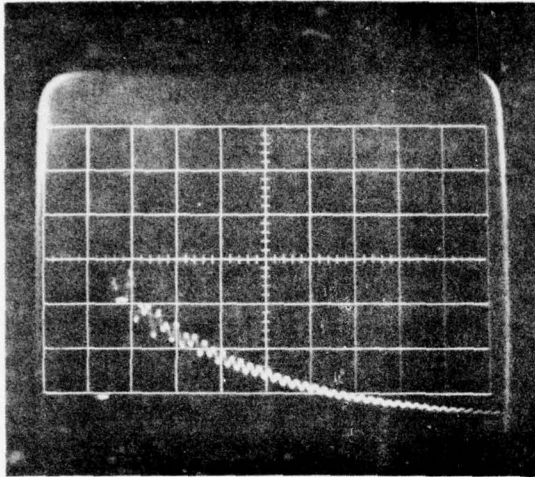

Figure 12. Typical pulse from e-field sensor for simulator EMP measurements.
Scale: 1 V/vertical division
200 nsec/horizontal division

a typical electric field measurement. The duration of the entire pulse is about 1 μ sec.

The 60-ft (18.3 m) length of optical fiber was used; 20 ft (6.1 m) of the fiber were placed between the two plates, and the remainder was used in going to and from the shielded enclosures.

The fiber was wrapped around a 6 in. \times 6 in. \times 2 in. (15.2 cm \times 15.2 cm \times 5.1 cm) cutout cube of polystyrene; the permeability of polystyrene is sufficiently close to that of air to prevent excessive distortion of the electric field. The fiber was oriented in three ways inside the field to eliminate any possibility that a cancellation effect was occurring in a particular orientation:

- a. the loops of fiber were placed parallel to the two conductors
- b. the loops were placed perpendicular to the conductors
- c. the fiber was mounted on a sheet of cardboard in a zig-zag fashion, not overlapping itself. Figure 13 shows the different orientations.

The LED and DC voltage drivers were placed in one shielded enclosure to eliminate the possibility of any signal being induced on the LED or driving system by the pulse. The fiber was passed through the field into the other shielded enclosure containing

the detection system. Because the fiber was longer than those used in the previous experiments, greater attenuation occurred with only a 2-V output signal.

The high frequency noise level of the output of the amplifier circuit was about 50 mV, so filtering was necessary. In selecting filter parameters, it was assumed that if a detectable disturbance in light transmission by the fiber occurred, its characteristics would be similar in time and frequency content to those of the applied EMP pulse. A filter was therefore designed to pass the 1- μ sec pulse shown in Figure 12. The filter, shown in Figure 14, was a band-pass type with lower and upper corner frequencies of 500 kHz and 5 MHz, respectively.

Although a noise level of 0.4 mV was still present after filtering, further filtering was not possible, since the frequency of the noise was within the spectrum of the expected signal. Figure 15, which is a picture of six consecutive oscilloscope traces of the noise, shows that the traces have similar appearances, but do not occur at the same time. The fourth and fifth traces look alike, but the fifth trace lags the fourth by about 0.5 μ sec. Examining many traces indicates that the noise pulses occur randomly in time.

Because of the random nature of the noise, a multiple exposure picture of many traces would integrate the traces into a broad, straight trace line; any repeating signal would cause a shift or change in the baseline of the wide trace. This technique of multiple exposure was used to improve the measurement range as much as possible.

To trigger the oscilloscope, a loop of wire was passed out of the enclosure and connected to the external trigger input on the scope. Operating the scope in the external trigger mode insured that all displayed traces would have the same time relationship relative to the applied EMP.

Test Results

Figures 16, 17, and 18 are multiple trace oscilloscope photographs showing the results for the fiber in parallel, perpendicular, and zig-zag orientations. As can be seen from the pictures, no detectable a deviation of 1 mm (.04 in.), or a 0.2-mV deviation and a constant 2-V DC signal gives it a measurement range of 80 dB. Thus, if there was any effect on the fiber, it was more than 80 dB below the normal signal level.

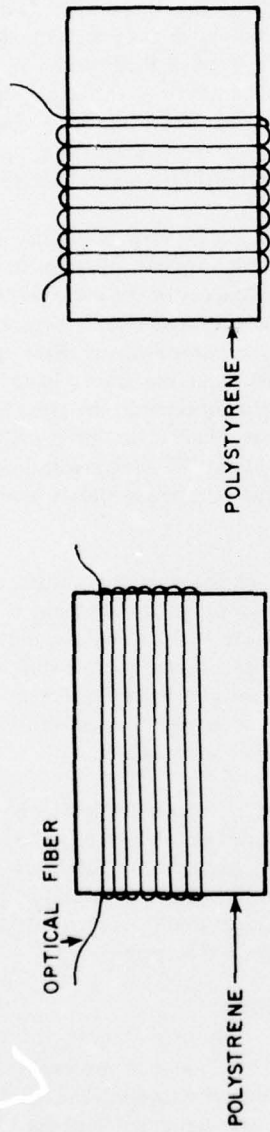

a - PARALLEL ORIENTATION

b - PERPENDICULAR ORIENTATION

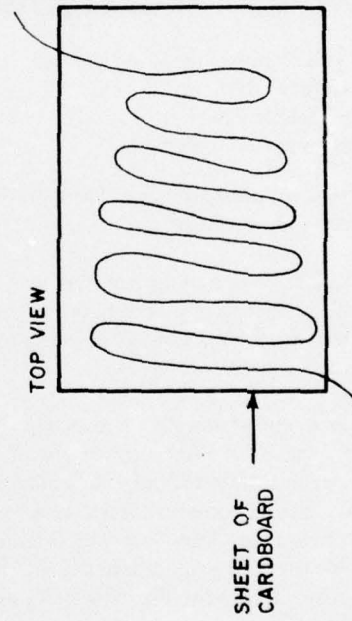

c - ZIG-ZAG ORIENTATION

Figure 13. Optical fiber orientations for light flash tests.

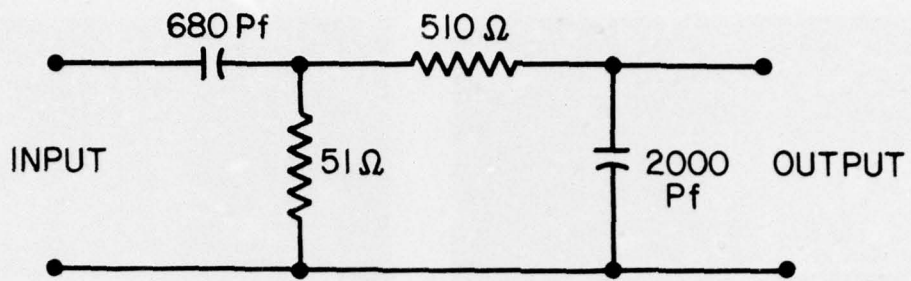

Figure 14. Band-pass filter.

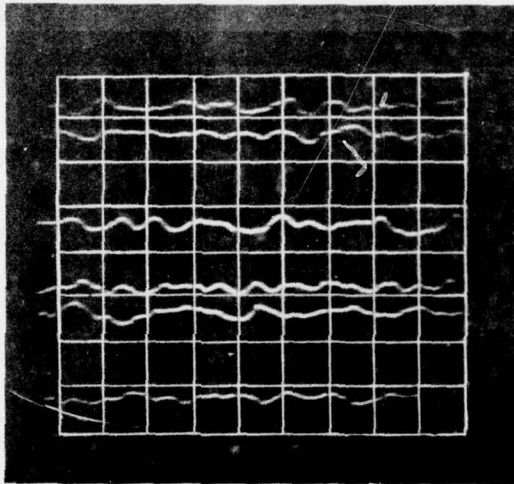

Figure 15. Six consecutive traces from photodetector amplifier during EMP subjection.
Scale: 2 mV/vertical division
1 msec/horizontal division

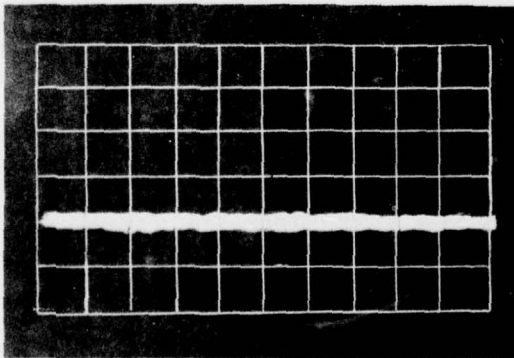

Figure 16. Multiple trace photo for parallel fiber orientation.
Scale: 2 mV/vertical division
1 msec/horizontal division

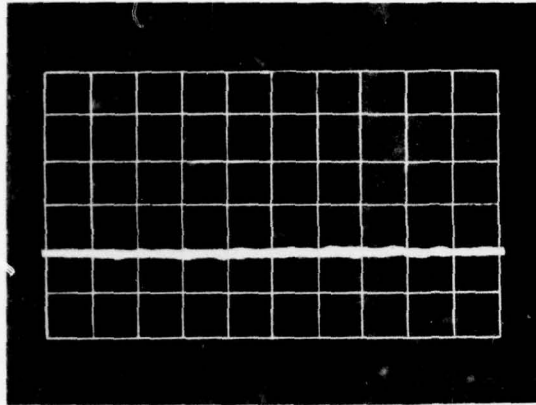

Figure 17. Multiple trace photo for perpendicular fiber orientation.
Scale: 2 mV/vertical division
1 msec/horizontal division

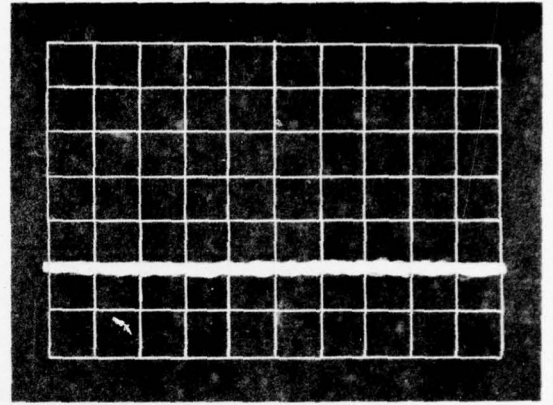

Figure 18. Multiple trace photo for zig-zag fiber orientation.
Scale: 2 mV/vertical division
1 msec/horizontal division

6 CONCLUSIONS

As expected, the EMP produced no interference with data transmission via the optical fiber system. Also as expected, of the four data transmission lines tested—the untwisted pair, the twisted pair, the coaxial cable, and the optical fiber—the untwisted pair was the worst case. The tests without steel wool packing at the ends of the conduit demonstrated that a metal conductor's data transmission line may permit an EMP to be conducted into the shielded enclosure; such a problem does not exist with the optical fiber.

The tests qualitatively demonstrated the metallic conductors' susceptibility to EMP at low levels. The optical fiber was found to provide error-free data transmission under the same test conditions.

The high-intensity light transient testing showed that black polyvinyl chloride jacketing over the fiber insures at least an 87.9 dB signal-to-noise ratio during the transient. For practical purposes, the fiber can therefore be considered immune to ambient light flashes.

Exposure of the fiber to an EMP of 1 000 000 V/m (914,400 V/yd) created no measurable noise signal. The system's dynamic range was such that a signal-to-noise ratio of at least 80 dB can therefore be assured.

CITED REFERENCES

- Black, H. S., *Modulation Theory* (Van Nostrand Co., Inc., 1953), Chapter 4.
- Nuclear Electromagnetic Pulse (NEMP) Protection*, TM 5-855-5 (Department of the Army, 1974).

UNCITED REFERENCES

- Biard, J. R., *Optoelectronic Aspects of Avionic Systems II*, Technical Report AFAL-TR-75-45 (Department of the Air Force, May 1975).
- Gagliardi, Robert M. and Sherman Karp, *Optical Communications* (John Wiley & Sons, 1976).
- Yariv, Amnon, *Introduction to Optical Electronics* (Holt, Rinehart and Winston, Inc., 1971).

CERL DISTRIBUTION

EPM

US Army, Europe
ATTN: AEAEN

Director of Facilities Engineering
APO New York 09827

DARCOM STIT-EUR
APO New York 09710

USA Liaison Detachment
ATTN: Library
New York, NY 10007

West Point, NY 10996
ATTN: Dept of Mechanics
ATTN: Library

Chief of Engineers
ATTN: Tech Monitor
ATTN: DAEN-ASI-L (2)
ATTN: DAEN-FEP
ATTN: DAEN-FEU
ATTN: DAEN-FESA
ATTN: DAEN-FE7-A
ATTN: DAEN-MC2-S
ATTN: DAEN-RDL
ATTN: DAEN-PMS (7)

for forwarding to
National Defense Headquarters
Director General of Construction
Ottawa, Ontario K1A0K2
Canada

Canadian Forces Liaison Officer (4)
US Army Mobility Equipment
Research and Development Command
Ft Belvoir, VA 22160

Division of Bldg Research
National Research Council
Montreal Road
Ottawa, Ontario, K1A0R6

Airports and Const. Services Dir.
Technical Information Reference
Centre
KACL, Transport Canada Building
Place de Ville
Ottawa, Ontario, Canada, K1A0N8

Aberdeen Proving Ground, MD 21005
ATTN: AMXHL/J. D. Weisz

Ft Belvoir, VA 22060
ATTN: ATSE-TD-IL (2)
ATTN: Kingman Bldg, Library

Ft Monroe, VA 23651
ATTN: ATEN
ATTN: ATEN-FE-U

Ft Lee, VA 23801
ATTN: DRXMC-D (2)

Ft McPherson, GA 30330
ATTN: AFEN-FEB

US Army Foreign Science & Tech Center
ATTN: Charlottesville, VA 22901
ATTN: Far East Office

USA-WES
ATTN: Library

6th US Army
ATTN: AFKC-LG-E

US Army Engineer District
Saudi Arabia
ATTN: Library
Pittsburgh
ATTN: Library
ATTN: Chief, Engr Div
Philadelphia
ATTN: Library
ATTN: Chief, NAPEN-D

US Army Engineer District
Norfolk

ATTN: Chief, NAOEN-M

Huntington

ATTN: Library

ATTN: Chief, ORHED-D

Wilmington

ATTN: Chief, SAWEN-D

Charleston

ATTN: Chief, Engr Div

Savannah

ATTN: Library

ATTN: Chief, SASAS-L

Mobile

ATTN: Chief, SAMEN-C

Nashville

ATTN: Library

Memphis

ATTN: Library

ATTN: Chief, LMED-DM

Vicksburg

ATTN: Chief, Engr Div

Louisville

ATTN: Chief, Engr Div

Detroit

ATTN: Library

St Paul

ATTN: Chief, ED-D

Rock Island

ATTN: Library

ATTN: Chief, Engr Div

St Louis

ATTN: Library

ATTN: Chief, ED-D

Kansas City

ATTN: Library (2)

ATTN: Chief, Engr Div

Omaha

ATTN: Chief, Engr Div

New Orleans

ATTN: Library

ATTN: Chief, LMED-DG

Little Rock

ATTN: Chief, Engr Div

Fort Worth

ATTN: Chief, SWFED-D

Galveston

ATTN: Chief, SWGAS-L

ATTN: Chief, SWGED-DM

Abbeville

ATTN: Library

San Francisco

ATTN: Chief, Engr Div

Sacramento

ATTN: Chief, SPKED-D

ATTN: Library, Room 8307

Far East

ATTN: Chief, Engr Div

Japan

ATTN: Library

Portland

ATTN: Chief, DB-3

Seattle

ATTN: Chief, EN-DB-EM

ATTN: Chief, NPSEN-PL-WC

Walla Walla

ATTN: Library

ATTN: Chief, Engr Div

Alaska

ATTN: Library

ATTN: Chief, NPADE-R

US Army Engineer Division
Europe

ATTN: Technical Library

New England

ATTN: Chief, NEDED-T

North Atlantic

ATTN: Chief, NAOEN-T

Middle East (Rear)

ATTN: MEDED-T

South Atlantic

ATTN: Chief, SADOEN-TE-TM

ATTN: Library

US Army Engineer Division
Huntsville

ATTN: Library (2)

ATTN: Chief, HNOED-MH

ATTN: Chief, HNOED-SR

Lower Mississippi Valley

ATTN: Library

Ohio River

ATTN: Library

ATTN: Chief, Ingr Div

North Central

ATTN: Library

Missouri River

ATTN: Library (2)

ATTN: Chief, MRDED-T

Southwestern

ATTN: Library

ATTN: Chief, SWDED-TM

Pacific Ocean

ATTN: Chief, Engr Div

North Pacific

ATTN: Chief, Engr Div

Facilities Engineers

Carlisle Barracks, PA 17013

Ft Campbell, KY 42223

FORSCOM

Ft Devens, MA 01433

USAECOM

Ft Monmouth, NJ 07703

USCPEP

West Point, NY 10996

USATCFE

Ft Eustis, VA 23604

USAIC

Ft Benning, GA 31905

USAAVNC

Ft Rucker, AL 36361

CAC&F (3)

Ft Leavenworth, KS 66027

USACC

Ft Huachuca, AZ 85613

TRADOC

Ft Monroe, VA 23651

Ft Gordon, GA 30905

Ft McClellan, AL 36201

Ft Sill, OK 73503

Ft Bliss, TX 79916

HQ, 7th Inf Div & Ft Ord, CA 93941

HQ, 24th Inf & Ft Stewart, GA 31313

HQ, 1st Inf Div & Ft Riley, KS 66442

AF/PREEU

Bolling AFB, DC 20332

AF Civil Engr Center/XRL

Tyndall AFB, FL 32401

Little Rock AFB

ATTN: 312/DEEE (Mr. Gillham)

Naval Air Systems Command

ATTN: Library

WASH DC 20360

Port Hueneme, CA 93043

ATTN: Library (Code LOBA)

ATTN: Moreell Library

Washington DC

ATTN: Building Research Advisory Board

ATTN: Library of Congress (2)

ATTN: Dept of Transportation Library

Defense Documentation Center (12)

Engineering Societies Library

New York, NY 10017

Commander
Naval Facilities Engineering Command
ATTN: Code 04
200 Stovall St
Alexandria, VA 22332

Commander
Naval Undersea Center
ATTN: Code 6511, McCardell
San Diego, CA 92132

Commander
USACEEIA
ATTN: CCC-S
Ft Huachuca, AZ 85613

U.S. Army Electronics Command
ATTN: ANSEL-NL-RM-1
Ft Monmouth, NJ 07703

Naval Electronics Laboratory Center
271 Catalina Blvd
San Diego, CA 92152

Naval Avionic Facility
ATTN: Dept 844
6000 E. 21st St
Indianapolis, IN 46218

Headquarters
Defense Nuclear Agency
Technical Library
WASH DC 20315