

ADAD32211

TR 76011

JANUARY

1976



Crown Copyright
1976

COPYRIGHT ©

CONTROLLER HMSO LONDON
1976

ROYAL AIRCRAFT ESTABLISHMENT
TECHNICAL REPORT 76011

BR52037

**THE EFFECTS OF 3 HOURS OF
VERTICAL VIBRATION AT 5Hz
ON THE PERFORMANCE
OF SOME TASKS**

by
R. Gray
R. T. Wilkinson
K. R. Maslen
G. F. Rowlands

NOV 4 1976

PROCUREMENT EXECUTIVE, MINISTRY OF DEFENCE
FARNBOROUGH, HANTS

18 DRIC

19 BR-52037

ROYAL AIRCRAFT ESTABLISHMENT

9 Technical Report, 76011

14 RAE-TR-76011

Received for printing 21 January 1976

6

THE EFFECTS OF 3 HOURS OF VERTICAL VIBRATION AT 5Hz ON THE PERFORMANCE OF SOME TASKS.

ACCESSION for	
NTIS	White Section <input checked="" type="checkbox"/>
DDC	Buff Section <input type="checkbox"/>
UNANNOUNCED	<input type="checkbox"/>
JUSTIFICATION	
BY	
DISTRIBUTION/AVAILABILITY CODES	
Dist.	Avail. acc./61 SPECIAL
A	

10 by R./Gray, R. T./Wilkinson*, K. R./Maslen, G. F./Rowlands

12 65p.

11 Jan 76

SUMMARY

A laboratory experiment has been conducted to investigate the effect on eight subjects of 3-hour exposures to vertical vibration, and to compare the results with the recommendations for maintaining efficiency of the International Standard ISO 2631 - "Guide for the evaluation of human exposure to whole-body vibration".

The vibration used was 5Hz vertical, with an acceleration level of 1.2m/s² rms, corresponding to the ISO recommended maximum durations of 1 hour for 'Fatigue & Decreased Proficiency' and 3 hours for safe 'Exposure'. The duration of each session was approximately 3 hours and four series of four sessions were conducted using two subjects at a time. Four tasks were used, audio vigilance, visual search, compensatory tracking by hand and handwriting. Effects on sight and hearing were checked at the beginning and end of each session. Based on average results, little evidence was found to support the time-dependency of the limits specified for 5Hz in the International Standard in that little fatigue effect was discovered. There was, however, an immediate appreciable decrement in performance of three out of the four tasks as a direct effect of the vibration, suggesting that the short-term nominal limit specified (2.8m/s² rms for 1-4min) is too high, for the particular tasks used.

Departmental Reference: FS 31 ✓

* MRC Applied Psychology Unit.

4

310450

AB

DDC RECEIVED NOV 4 1976 RECEIVED D

CONTENTS

	<u>Page</u>
1 INTRODUCTION	5
2 EVOLUTION OF THE MAIN EXPERIMENT	6
2.1 The vibration used	6
2.2 The tasks used	6
2.3 Audio and visual tests	7
2.4 Subjects	7
2.5 Pilot experiment	7
3 APPARATUS	8
3.1 Vibration rig	8
3.2 Seats	8
3.3 Equipment and fittings on vibrations rig	9
3.4 Instrumentation	10
4 EXPERIMENTAL PROCEDURE	10
4.1 General arrangements	10
4.2 Wilkinson vigilance task	11
4.3 Search task	12
4.4 Tracking task	13
4.5 Writing task	14
4.6 Measurement of sight and hearing	14
5 EXPERIMENTAL DESIGN	14
5.1 Plan of experiment	14
5.2 Programme of tasks	15
6 RESULTS	16
6.1 General presentation	16
6.2 Vigilance task	16
6.3 Visual search task	16
6.4 Tracking task	16
6.5 Writing task	17
6.6 Statistical analysis	17
6.6.1 The statistical test used	17
6.6.2 Results of statistical analysis	17
6.7 Sight and hearing measurements	18
6.8 Subjects' comments	19
7 DISCUSSION	19
7.1 Vigilance task	19
7.2 Visual search task	19

CONTENTS (concluded)

	<u>Page</u>
7.3 Tracking task	20
7.4 Writing task	21
7.5 Sight and hearing measurements	21
7.6 Subjects' comments	21
7.7 Individual versus average results	21
8 CONCLUSIONS	21
9 FURTHER WORK	23
Acknowledgments	23
Appendix A Signal produced for the Wilkinson vigilance task	25
Appendix B Tracking task	26
Tables 1 to 3h	33
References	42
Illustrations	Figures 1-21

1 INTRODUCTION

In the International Standard "Guide for the evaluation of human exposure to whole-body vibrations"¹ three main human criteria are distinguished, and corresponding boundaries of allowable vibration intensities and durations are defined as shown in Fig.1. These criteria and the corresponding boundaries are (Ref.1, section 4.1).

- (a) the preservation of working efficiency (Fatigue-Decreased Proficiency boundary);
- (b) the preservation of health and safety (Exposure Limit);
- (c) the preservation of comfort (Reduced Comfort Boundary).

All of these boundaries, for a given frequency, show a marked reduction in acceptable acceleration level with duration of exposure, but the precise meaning of this time-dependency is not clear. The Standard¹ is ambiguous in this respect: section 4.1.1 implies that the F-DP limits can apply to single exposures, for example to vehicle driving, whereas in section 4.4.1, it is stated that all the limits relate particularly to working life that is repeated daily exposures, rather than to single or occasional exposure.

A previous study² suggested that there is very little ground in published literature for supposing that efficiency at various tasks is in any way related to the duration of vibration in general or to the duration of the Fatigue-Decreased Proficiency (F-DP) boundary in particular. The evidence has been mainly gathered from reports in which testing the relevance of the F-DP boundary was not a specific object. It was therefore thought desirable to undertake an experiment specifically with this aim*.

The interpretation that many people have put on the Standard is that efficiency at any task will be reduced if the recommended duration at a given vibration is exceeded, whatever the kind of task or however often its performance is required during that time. To investigate this, different types of task, performed at intervals, were thought to be capable of showing the effect, if it exists.

The form of the experiment was devised in collaboration with the Applied Psychology Unit of the Medical Research Council, and was carried out at RAE jointly by staff of both establishments:

Preliminary results of this experiment have been reported in a paper entitled "Effects of duration of vertical vibration beyond the proposed ISO Fatigue-Decreased Proficiency time, on the performance of some tasks" given at an AGARD symposium in April 1974. Further analysis has resulted in some modification of the conclusions reported there.

* Since this experiment was completed, a somewhat similar experiment has been reported by Bennett *et al.*³. Their conclusions are broadly in agreement with those of this Report.

2 EVOLUTION OF THE MAIN EXPERIMENT

2.1 The vibration used

The object of the experiment was to determine the effect, if any, of prolonged exposure to vibration on the ability of subjects to perform various tasks. The broad outline plan of the experiment was as follows:-

- (1) The vibration should be vertical and nominally sinusoidal of 5Hz frequency, since this is in the neighbourhood of the major body resonance and is consequently the type of vibration which has occurred most frequently in earlier experiments. It would, therefore, possibly allow for some comparison with other published results.
- (2) The duration of vibration should be long enough for any fatigue effects to become obvious; the time fixed on was 3 hours.
- (3) The level of the vibration should not exceed the ISO recommended 'exposure limit for 3 hours'. This was thought to be desirable, particularly if the standard applies to single exposures. The level chosen was 1.2m/s^2 rms, equivalent to an F-DP boundary of about 1 hour and an exposure limit of about 3 hours.

2.2 The tasks used

The following four tasks were chosen; the first two were provided by APU and the second two by RAE:-

- (i) The Wilkinson vigilance task⁴, which has been used by APU for several years provides a method of measuring the level of alertness of subjects throughout a lengthy period of signal detection. A description is given in section 4.2 and details in Appendix A.
- (ii) A visual search task which has also been in use at APU for some time and provides a measurement of visual acuity and the ability to search a visual field. A description is given in section 4.3.
- (iii) A tracking task which has been used in a similar form by RAE for various experiments provides a means of measuring the level of visual and muscular co-ordination of subjects, which is important when flying an aircraft, driving a motor car, etc. A description of the task is given in section 4.4 and details in Appendix B.
- (iv) A writing task was used as a second method of measuring the level of visual and muscular co-ordination of subjects by a common everyday task,

frequently used in transport. A description of this task is given in section 4.5.

2.3 Audio and visual tests

It was thought possible that sight and hearing (and hence task performance) might be degraded by fatigue effects caused by the prolonged tasks and/or prolonged exposure to vibration. To check any such effects, three standard tests of sight were used, a seven-line near-point reading chart, a Maddox Wing and an RAF near-point rule, and an audiometric test was used to check hearing threshold at two frequencies.

2.4 Subjects

The eight subjects were all men aged between 19 and 37 and employed at RAE, who volunteered either in response to an invitation to take part issued to the RAE in general, or as a result of direct approaches made by the experimenters. The latter were all from the same department as the RAE experimenters though they were not familiar with the work of the Environmental Effects Section.

Before taking part in the tests all subjects were examined by the Senior Medical Officer at RAE and passed as fit to take part.

2.5 Pilot experiment

Before embarking on the main experiment a pilot experiment was conducted using two subjects. This was in order to look for any unexpected problems and to check that subjects would tolerate the proposed periods of vibrations and tasks. The pilot experiment was carried out with all vibration and task conditions as close as possible to those intended for the main experiment.

The most important conclusion of this pilot experiment was that it was necessary for subjects to practice the tracking task thoroughly beforehand, in order to minimize learning effects during the main experiment. The pronounced learning curve of one of the subjects had been very obvious from his results during the week. As a result of this experiment it was also decided that subjects should be deprived of any actual time reference, so that their only knowledge of the time would be from the experimenters and this knowledge, if necessary, could be artificial. This decision was taken when one subject's task performance was found to have been apparently adversely affected by the fact that the later stages of the session had encroached on his normal mid-day break. Subjects' wrist watches were consequently removed during the main experiment.

It was also recognised that any visual or oral contact with the world outside the vibration rig should be restricted to controlled communications from the experimenters. During the pilot experiment slight external disturbances noticed by the subjects affected their task performance. Great care was therefore taken during the main experiment, to isolate the subjects from the outside world.

3 APPARATUS

3.1 Vibration rig

The experiment was carried out on the RAE two-axis vibration rig⁵ (Figs.2 and 3). This apparatus has a 1.83m by 1.22m platform which can be vibrated in the vertical axis and one horizontal axis. The frequency range of the rig is from 0.5 to 50Hz, within the limitation of a plus and minus 0.25m stroke and a maximum acceleration of 19.62m/s^2 . The rig was tuned to accept a working load of 270kg.

A sound-deadening, noise-attenuating chamber encloses the whole rig. This has an air circulating and temperature control system which maintains a selected temperature within $\pm 1^\circ\text{C}$ and completes approximately six air changes per hour. An intercommunication system is installed with three pairs of jack plug sockets on the inside wall of the chamber, two sockets on the vibration table and two pairs of sockets outside the room. Headsets can be connected to these sockets in order to facilitate communication where required.

A large window is built into the wall of the chamber nearest to the control consol so that the rig operator can easily see the vibration platform. In order that the subjects should not be distracted by movements outside the chamber a one-way window effect was arranged by attaching lengths of 25.4mm wide tape on the window with about 10mm gaps between each strip. The inside face of these strips was aluminised while the outside was matt black. With the light bright in the chamber and dim outside a window/mirror effect was achieved.

3.2 Seats

The space available on the vibration rig platform is sufficient to accommodate two subjects at the same time. It was apparent that the utilisation of this facility would not only halve actual testing time but would also provide a measure of control between subjects. A pair of seats divided by a screen was therefore designed and constructed. Although the base securing members were made of steel the main structure was of wood, since this provides a more comfortable environment for the subjects.

The major dimensions of the seats were all derived from recommendations published by the Department of Scientific and Industrial Research⁶. The whole structure was stressed for a maximum vibration level of $\pm 0.5g$. Each seat was fitted with an arm-rest on either side and a 'dry-fluid'⁷ squab on the back-rest. This squab was attached by velcro and was adjustable in height. A dry-fluid cushion was fitted to each seat pan providing comfort for all subjects while transmitting the vibration input from the seat pan to the subject with little modification. The seats are illustrated in Figs.2 and 3.

3.3 Equipment and fittings on vibrations rig

An equipment table and angled writing desk were mounted in front of each seat (Figs.2 and 3), supported by the dividing screen on the right hand side and a rigid frame on the left. These carried the oscilloscopes used in the tracking task and the ancillary equipment (books, writing pads, pencils and response boxes) for the other tasks (see sections 4.2, 4.3 and 4.5). The oscilloscopes would be adjusted in height at their forward end in order to suit different eye levels.

A small two-axis control stick (connected in the fore-and-aft axis only) of the type used for radio-controlled models, was used for the tracking task. This was fixed to the dividing screen so that its mounting plate formed a slightly lowered extension to the right hand arm-rest of each seat. It was arranged to be in as comfortable position as possible for operation in the fore-and-aft axis.

Headphones with boom microphones and transmit switches were connected into the rig intercom system, and were worn by each subject throughout the sessions. However, subjects were instructed to use their microphones only in exceptional circumstances. The cables for the headsets were attached to the top of the dividing screen, while all other cables were either fixed to the seats or concealed inside the cavities beneath the seat pan so as to present as comfortable and uncluttered an environment for the subjects as possible.

Three major safety features were built into the structure of this equipment (see Figs.2 and 3); they were:-

- (i) A foot guard fitted across the edge of the vibration platform beneath the equipment table, designed to prevent subjects' feet extending over the edge of the platform.

- (ii) A civil-aircraft, passenger-type lap strap fitted to each seat; subjects were instructed to wear this at all times.
- (iii) A large 'stop' button placed to the left of each oscilloscope; the operation of either of these buttons would shut down the vibration rig at any time.

In order to maintain a constant watch on both subjects a television camera was focussed on the subject facing away from the chamber window in front of the control consol. A monitor connected to the camera was placed on top of the control consol so that the vibration rig operator could watch both subjects at the same time.

3.4 Instrumentation

The only instrumentation used on the rig, apart from that associated with the tasks, was a system for monitoring the vibration level at the base of the seats. This consisted of a piezo-resistive accelerometer (Ether type No.BLA2) attached to one of the steel seat mounting members and forming half of a Wheatstone bridge. The other half of the bridge was incorporated in an SEL ac carrier amplifier, the output from which was fed to a Solartron Digital Transfer Function Analyser. This was also supplied with a reference signal from the main driving oscillator of the vibration rig. Throughout the tests the vibration level was monitored on the TFA and maintained at a constant level by minor adjustments of the vertical gain control of the vibration rig when necessary.

4 EXPERIMENTAL PROCEDURE

4.1 General arrangements

Before taking part in the tests all subjects were examined by the Staff of the Medical Services Department at RAE and passed as fit to take part in the vibration tests. The Senior Medical Officer also supplied a medical attendant during the vibration sessions - this was unknown to the subjects.

During the week preceding each series of tests, subjects attended short sessions at the rig on most mornings and afternoons. The purpose of these visits was primarily to instruct them, and then to allow them practice runs on the tracking task, both with and without vibration. They were also instructed in the writing task, allowed to experience the vibrations for a time and generally to become accustomed to the surroundings and feel of the equipment. The first day

of the tests week was for instruction and practice purposes. Subjects were carefully briefed on the importance of the experiment and its dependence on their consistent co-operation and perseverance throughout the week. The method of scoring was fully explained including the fact that some of their results would be given to them and displayed outside the test chamber while other results would not be displayed and they, nor any of the other subjects, would ever know the scores. As far as was possible on this first day the programme of tasks that was to be followed on the ensuing days was adhered to. It was however necessary for the experimenters to enter the chamber from time to time for instruction purposes. On the other four days it was intended that the doors of the chamber should remain closed from start to finish. All conditions within the chamber were kept as similar as possible on the first day to those to be used during the rest of the week.

Before each session began, subjects' watches were removed so that they would have no time-reference during the tests except those they associated with the programme of tasks and those introduced by the experimenters. Subjects were supervised while taking their place on the vibration rig and their seat belts checked for correct positioning. They were instructed not to leave their seats without the permission and attendance of a member of the experimental team except, if an emergency occurred, after pressing the 'stop' button and allowing the rig to park.

Throughout the experiment conditions in the chamber were kept as constant as possible; the temperature was maintained between 72° and 74° C. The only real variations in test conditions apparent to the subjects were the presence or absence of the vibration and their knowledge or lack of knowledge of their results (see section 5.1). Subjects were reminded before each task whether they would have this knowledge of their results or not. When knowledge of results was supplied it was done for the vigilance and tracking tasks, immediately on completion of each task. Each subject, of course, knew how well he performed in the search task, but he was told his co-subject's score at the end of each 'with knowledge of results' sessions. The writing was not marked till after all the sessions were completed. The 'with knowledge' results were marked up on a board outside the vibration chamber so that each subject could compare his results with those of others.

4.2 Wilkinson vigilance task

For this task subjects are asked to listen to short tones (600Hz) transmitted to their headphones at two-second intervals against a background of

nominally white noise. The majority of these notes are of nominally 500ms duration with occasionally (on average, every 1½min) one of nominally 400ms duration - the signal. The object of the task is to detect these short notes. Subjects were instructed to press a white button on their response box (Fig.4) immediately they detected one and then to press another button to indicate their level of confidence in their detection of the signal. The standard procedure was used for these tests, although there was no intention of analysing the confidence ratings because the number of subjects was too small to yield useful results.

The response from the buttons was recorded on a two-channel pen recorder which also recorded the occurrence of actual short tones. The duration of each vigilance task was one hour.

On a practice day, before each series of tests, recorded instructions were played to the subjects; these presented them with all the information they required to carry out the task. This was followed by a programme of tasks similar to those they would have to complete on the other four days of the week. On the first of these days, the first one-hour vigilance task was preceded by a further short period of instruction and practice.

The number of signals detected were scored for each subject after each quarter of an hour, as well as for the whole task. False detections and levels of confidence were also noted.

On each response box was a red button which was connected to a warning light on the control console of the vibration rig. Subjects were asked to use this button should they want to attract the attention of the experimenters at any time.

Before the tests commenced, recordings were made of the noise received at the ears of each subject during the vigilance task, under test conditions. Details of the technique and the results obtained are given in Appendix A.

4.3 Search task

Each subject was provided with a booklet containing printed sheets of random letters (an example is illustrated in Fig.5). At the top of each page was written a letter (in Fig.5, the letter, s) of which there were only five similar letters on that page; subjects were asked to find and circle these 'targets'. They were instructed to search in any way they wished but to continue searching until they had found all five targets. Then, and only then, were they to turn

to the next sheet where a different target would be shown at the top, and a fresh search began. This was to be continued until they were instructed to stop; the duration of the task was 12min. At three-minute intervals the subjects were instructed over the intercom to mark their books: 1 after 3min, 2 after 6min and 3 after 9min in the right hand column of the page they were searching, the number to be positioned according to the number of targets they had found on the page at that time, i.e. one target - 1/5 of the way down the page, two targets - 2/5 down, etc. At the end of the 12min subjects were asked to draw a line at the bottom of the page they were searching and to put the books to one side and face downwards - this precaution being taken to avoid any temptation to look at the books during the vigilance task.

Each 12min trial was scored according to the total number of targets detected.

4.4 Tracking task

For this task the subject uses a small control stick, of the type used for radio-controlled models, to track a task displayed on an oscilloscope. The screen of the oscilloscope has one horizontal line across it which can be moved either by the movement of the control stick in its fore-and-aft axis, or by an external voltage applied to the Y-axis of the oscilloscope. The task is of the compensatory type; any displacement of the control stick resulting in a directly proportional displacement of the line. When the external signal voltage is switched to the oscilloscope the line moves up and down the screen, while the subject attempts to keep it on the centre line by movements of the control stick. Pointers are positioned on either side of the screen to help subjects identify the centre during the task.

The task error is proportional to the distance of the line from the centre of the screen. This error, as a voltage level in the task equipment, is integrated over the tracking period, which for this experiment was taken as 3min; the integral being recorded as the error score. The movement of the line and the integrated error for each subject was recorded during each task on a four-channel pen recorder; an example of the traces recorded is shown in Fig.6.

The input voltage of this tracking task is of a dual frequency repetitive nature, which a subject learns with practice. It is therefore necessary for subjects to practice the task, prior to the commencement of the tests, until their scores cease to show any improvement between runs. This practising was

carried out during the week preceding each series of tests, when subjects completed two tasks on each morning and afternoon until their scores stabilized both with and without vibration. This learning period also served to filter out unsuitable subjects. For this experiment, one volunteer was found whose learning curve showed no signs of levelling out, and he was not used as a subject.

A full description of the dimensions and construction of this task is given in Appendix B.

4.5 Writing task

Each subject was provided with a shorthand note-pad and a pencil, and an example of the writing task was attached to the left hand side of their writing desks. This is illustrated in Fig.7. The experimenter instructed the subjects when to carry out the task and at the same time informed them of the date and time of day. The quality of each transcript was later assessed by a school-teacher using a 0-10 scale.

4.6 Measurement of sight and hearing

In order to try to detect any visual fatigue effects a series of measurements were made before and after each session. The ability to read at close proximity was measured using a seven-line near-point reading chart; six charts were used during the tests so that subjects would not become accustomed to any one. Subjects near point and accommodation point were measured using an RAF Near Point Rule, while by using a Maddox Wing the degrees of hyperphoria or hypophoria and esophoria or exophoria present in the alignment of subjects' eye axes could be measured.

To detect any aural fatigue, audiometric measurements were conducted on each ear of each subject before and after each day's sessions. The subjects' threshold of hearing was noted for 500Hz and 4kHz.

5 EXPERIMENTAL DESIGN

5.1 Plan of experiment

The arrangement of the variables vibration and knowledge of results for each pair of subjects is shown in the table below.

Day \ Subject	1	2	3	4
a } b }	NV/K	V/NK	V/K	NV/NK
c } d }	V/NK	NV/K	NV/NK	V/K
e } f }	NV/NK	V/K	V/NK	NV/K
g } h }	V/K	NV/NK	NV/K	V/NK

V = with vibration
 NV = with no vibration
 K = with knowledge of results
 NK = with no knowledge of results

5.2 Programme of tasks

A timetable of the sessions' programme is given in Fig.8. The order of tasks for each session was arranged as three series of the short tasks divided by two periods of the vigilance task. The timing of the short tasks was as follows:-

Period of elapsed time (min)	Task started
0	tracking
4	writing
5	search
19	tracking
23	finish

The duration of each of the vigilance tasks was one hour, and the overall programme of tasks was as follows:-

Period of elapsed time (min)	Task started
0	short tasks
23	vigilance task
84	short tasks
107	vigilance task
168	short tasks
191	finish

The times listed are approximate but only slight variations were observed on days one to four. The practice day took somewhat longer due in part to approximately an extra 20min at the beginning for the vigilance task instruction tape and also to the explanations and instructions required during the session in general.

6 RESULTS

6.1 General presentation

The age, height and weight of each subject are shown in Table 1, while the audio and visual measurements taken before and after each session are recorded in Tables 2a to 2h. Subjects' scores for the four tasks are shown in Tables 3a to 3h, each table having a complete set of results for each subject. Tables 2 and 3 have the experimental condition as given in section 5.1 shown at the top of each session's result column.

6.2 Vigilance task

The quarter hour scores for each subject on each test day (session) are shown in Tables 3a to 3h. These scores have been averaged to show the difference between the no-vibration (NV) and vibration (V) cases (Fig.9) and the difference between the four different combinations of test conditions (V/K, V/NK, NV/K, NV/NK) over the one-hour duration of the task (Fig.10). Fig.11 again illustrates the difference between the no-vibration and vibration cases but with the first and second tasks of each day treated separately. The average vibration values have then been divided by the average no-vibration values in order to obtain the relative efficiencies and these are illustrated in Fig.12.

6.3 Visual search task

The averaged results of all eight subjects are shown in Figs.13 and 14 (no consideration has been given to the effect of knowledge of results on the subject's performance of this task).

Fig.13 shows the results of the three tasks carried out during each session for the vibration and no-vibration cases. Fig.14 shows the performance efficiency in the vibration case in relation to the no-vibration case.

6.4 Tracking task

The tracking task error scores, averaged for all subjects, for each of the four test conditions are shown in Fig.15 plotted against the elapsed time of the task sessions. Fig.16 shows the variation of the vibration and no-vibration

scores, while Fig.17 is a plot of the relative efficiency calculated as the reciprocal of the fraction of the tracking error under vibration in relation to the error scored with no vibratic. present.

A record was made of the tracking errors scored by each subject during both the actual test sessions and the training sessions carried out before the tests began. These are all plotted for each subject in Fig.20.

6.5 Writing task

The marks awarded for each subject's written task have been averaged for the vibration and no-vibration cases and are plotted in Fig.18. Relative efficiency has again been calculated as the score under vibration in relation to the score with no vibration and is shown in Fig.19.

6.6 Statistical analysis

6.6.1 The statistical test used

The test used for this analysis was the Wilcoxon Matched-Pairs Signed-Ranks Test described by Siegel in Ref.8. Throughout this section 'not significant' unqualified means that the difference was not statistically significant at the 5% level.

6.6.2 Results of statistical analysis

(a) Vigilance task

The overall difference in performance due to vibration was moderate and failed to reach significance. Performance declined from first to second vigilance tests in the session ($P < 0.02$), This deterioration was significant with no vibration ($P < 0.02$) but not with vibration present. Thus the overall effect of vibration was to reduce within-session deterioration in performance, although the interaction term was not significant.

If, however, the knowledge (K) and no knowledge (NK) of results conditions are considered separately contrasting trends appear in the second test run of the three hour session. With K vibration impaired performance but not significantly, with NK it improved it, though not significantly. This contrast in the effect of vibration as a function of whether conditions are motivating or not is reflected in the interaction between the vibration and knowledge of results variables $((NV/K - V/K) - (NV/NK - V/NK))$, which increased during the course of the session from first to second test run but not significantly.

Fig.9 shows how performance deteriorated from first to second half of the test with both V and NV ($P < 0.01$ in each case). The deterioration was only slightly more with vibration than with no vibration, the difference failing to reach significance.

When motivation is considered (Fig.10) contrasting effects of vibration again appear as a function of time within the test and, while not significant, are in the same direction as those for time between tests during the course of the three-hour session: vibration impairs performance with time when conditions are motivating (K) but not otherwise (NK).

Finally, false reports showed no relevant significant changes.

(b) Visual search task

In this task a significant ($P < 0.05$) adverse effect of vibration in the first run was reduced to insignificance by the third. The variable of knowledge of results introduced no significant changes.

(c) Tracking task

Performance was worse in the vibration than in the no-vibration sessions, ($P < 0.05$) and this was more pronounced with no-knowledge of results than with knowledge, although this interaction was not significant. In terms of within-session changes, performance improved during the sessions both with and without vibration.

This improvement was more marked, though not significantly so, with vibration.

(d) Handwriting task

Vibration clearly impaired handwriting ($P < 0.02$). There was a deterioration not significant from first to third trial in both conditions.

6.7 Sight and hearing measurements

The results of the optical and aural measurements are recorded for each subject in Table 2. The test conditions of each day are shown, and the number of the reading chart used. Where values of seven for the reading chart and six for the near point are recorded, it indicates that the subject has achieved the maximum of the equipment, since the reading charts had seven lines and the minimum distance on the RAF near point rule is 60mm. The red (vertical) scale of the Maddox Wing was read as up-positive and down-negative, where positive indicates hyperphoria and negative hypophoria. The white scale was read with

odd numbers to the left and even numbers to the right, where even numbers indicate esophoria (divergence in) and odd numbers exophoria (divergence out).

6.8 Subjects' comments

During the experiment the comments of subjects in relation to the vibrations severity and duration were noted. The initial reactions of all subjects to the vibration was one of concern that they were expected to tolerate the vibration for over three hours. However, after a very short time they became less alarmed, and by the end of each vibration session indicated that the vibrations caused them much less discomfort than they had originally anticipated. In fact, subjects, in general, became more concerned at the length of time they were required to spend on the rig than about whether the vibration was going to be on or off.

7 DISCUSSION

The statistical significance of the differences discussed below are given in section 6.6. The following is a qualitative discussion of the results.

7.1 Vigilance task

The average performance of this task is apparently little affected by the introduction of vibration; the signals detected are, on average, the same under both vibration and no-vibration conditions (Fig.9). The results show a greater variation when the knowledge (K) and no-knowledge (NK) cases are treated separately (Fig.10). The no-knowledge results are shown as somewhat inferior to the with-knowledge results, while the fourth quarter scores, with knowledge of results, is the only place where a difference is found between the vibration and no-vibration cases. The difference here however shows the better scores with the vibration present.

When the two tasks of each session are treated separately, and considering the no-knowledge and with-knowledge cases combined, little difference is again apparent between vibration and no-vibration cases (Fig.11 and Fig.12). What difference there is occurs in the second task and does not suggest any decrement in performance throughout the session due to the presence of the vibration.

7.2 Visual search task

The averaged results of this task are plotted in Fig.13 against elapsed time. They show a slightly impaired performance under vibration compared with no-vibration. Under both conditions the third task shows an improved performance

compared with the first two tasks. The relative efficiency curve (Fig.14) shows no evidence of there being any time-dependent performance decrement due to the vibration during the period of the test sessions.

The very wide scatter in results, both inter and intra-subjects, may be partly attributed to the fact that each page (five targets) had to be completed before proceeding to the next page, so that subjects tended to be stuck when they needed only one or two more targets to complete the page. Out of the 96 scores 43 were at 10 or less and of these no less than nine were at 4, and 16 were at 9. The effect was less evident when the search was running smoothly and higher scores achieved. There was no apparent difference in this effect with duration or vibration.

7.3 Tracking task

Fig.15, which illustrates the trends of tracking error for the four separate test conditions shows little effect of knowledge/no-knowledge of results, except under vibrations where the error scores with knowledge of results are consistently a little less than with no knowledge of results. It is apparent in Fig.15 and substantiated by Fig.16, which shows the difference between vibration and no-vibration tasks, that the tracking errors were larger under vibration. The relative efficiency (Fig.17) shows that during the test period there is, after the initial impairment of task performance due to the vibration, a further drop in performance over about the first 20min due to the presence of the vibration. This is followed by an increase in relative performance up to somewhere between the 103rd and 168th minutes followed by a final decrease. The relative efficiency curve therefore suggests that there may be some vibration-related time effect resulting in a decrease in task performance after about two hours. However, at the end of the three hours the task was still being performed more efficiently than at a point 20min from the start.

The complete sets of tracking error scores for each subject shown in Fig.20, provide additional information on the performance of tracking tasks in general and of this task in particular. Examination of each subject's results reveals the very great differences which exist between the amount of learning and rate of learning achieved, and the different levels at which subject performance becomes constant. The authors believe that this is a very important point to be considered when conducting future experiments involving tracking tasks. Ideally subjects' results should have been consistent both with and without vibration before the test sessions were begun. Unfortunately, although

the scores without vibration showed little evidence of learning during the testing days, there was evidence of some learning under vibration (subjects a, b, c and h). The effects of this continued learning would however be largely eliminated in the analysis by the balanced arrangement of the vibrations/ no-vibration conditions.

7.4 Writing task

As would be expected a considerable impairment of clarity is caused by the vibration; this is illustrated in Fig.18. On average subjects were only just over 60% as efficient under vibration as they were without. However, there appeared to be no time-related effect of the vibration on the performances of this task (Fig.19).

7.5 Sight and hearing measurements

None of the four tests made on each subject before and after each session shows any differential fatigue effect between the vibration and no-vibration cases. As would be expected a slight and temporary threshold shift of subjects' hearing was recorded after each test, this would probably be due to the total of two hours' exposure to the noise of the vigilance task. There is however, little evidence of a decrement in near point and accommodation point after each session.

7.6 Subjects' comments

The comments of subjects on the vibration level and duration of exposure illustrate the immediate problems involved in subjective assessment experiments. The human tolerance to vibrations, at this frequency at least, is far greater than the subjects at first thought.

7.7 Individual versus average results

As a general point it should be noted that all the statistical analyses for significance are based on average not individual results. The experimental design inhibits examining the latter (individual replications would have been needed, making the experiment too lengthy). Inspection of the results suggests that there were no major differences in subjects' reactions to vibration or time.

8 CONCLUSIONS

This experiment was evolved to explore the validity of certain aspects of ISO International Standard 2631¹. Since the experiment was completed the British Standards Institution has published a Draft for Development "Guide to the

Evaluation of Human Exposure to Whole-Body Vibration"⁸, which suggests the same limits. The findings of this Report may therefore be related to both of these documents. It should however, be remembered that only one acceleration level (1.2m/s^2 rms) at one frequency has been examined and consequently the conclusions drawn apply only to this one condition; they do not necessarily apply to any other part of the 'Guides'. Also, the conclusions only apply to the effects of a very limited number of exposures (2×3 hours per subject), and do not therefore, cover possible cumulative, working life exposure effects. Lastly, the conclusions apply to mean results from eight subjects. Individual effects could well be different although there were no major differences obvious between the reactions to vibration or time of the eight subjects tested.

The time-dependency in the Fatigue-Decreased Proficiency boundary specified in the Standards has not been substantiated by this experiment. The F-DP boundary implies that a decrease of proficiency should have occurred after a period of about one hour, but none of the tests showed any decrement in performance (other than that initially obtained due to vibration) after this period of time. In fact the tracking task showed considerable improvement in performance after about 40min. This task was however, the only one that provided any evidence of a time-linked performance decrement during the three hours, and this occurred after about two hours of vibration. The decrement was, however, of insufficient magnitude and too near the end of the session to be conclusive. The other three tasks provided no evidence of any performance decrement due to prolonged vibration effects, in fact the vigilance task and visual search task showed some indication of improvement during the later stage of the sessions. This was, however, only slight, and could be due to scatter.

Although not the prime objective on this investigation, certain conclusions can be drawn regarding the F-DP levels for short exposures. The Standards suggest that nominal maximum levels of 2.8m/s^2 rms at 5Hz for 1-4min exposure to vertical vibration, will not produce 'a significant risk of impaired working efficiency in many kinds of tasks'. In fact although the acceleration used (1.2m/s^2) was well below this level, it still caused an immediate appreciable decrease in performance in three out of the four tasks used (visual search, tracking and writing). This underlines the importance of the 'Note' in the Standards, that a correction factor of between 1.4 and 0.25 times the nominal values may be needed to cover the different sensitivities to vibration of various kinds of task.

Similarly, some comments can be made on the accuracy of the 'Reduced Comfort Boundary' and the 'Exposure Limit'. The Standard implies that, since the level of vibration used in the experiment was above the 1-4min Reduced Comfort Boundary, the vibration would be immediately uncomfortable. This was found to be so, every subject's initial reaction being one of considerable discomfort. However, subsequent comments indicated that subjects tended to suffer less discomfort as the vibration continued and they appeared to adapt to it. The duration of the daily sessions was just over three hours, coinciding with the 'Exposure Limit'. It was found however, that subjects were not distressed in any way by being exposed to the vibration for this length of time. The only discomforts were those normally associated with sitting in one place for such a period of time. These findings underline the pitfalls inherent in the present widespread practice of assessing comfort reaction by a very short exposure to vibration and in the associated practice of *estimating* tolerable times from such an exposure.

The measurements of subjects' visual acuity and hearing threshold made before and after each three-hour session, indicate that there was no obvious visual or aural fatigue caused by the prolonged tasks or by the prolonged exposure to vibration.

9 FURTHER WORK

No further work is planned at RAE at present, but if further time-dependency experiments are carried out, it is suggested that these should look into the effects on individuals, the effects of random as opposed to sinusoidal vibration and the effects of prolonged vibration on the performance of continuous tasks.

Acknowledgments

The authors would like to thank Dr. G.E. Morley, Senior Medical Officer at RAE and members of his staff for their advice and help, both before and during the tests. Thanks are also extended to the subjects whose patience and resoluteness during a very tedious exercise are very much appreciated.

Appendix ASIGNAL PRODUCED FOR THE WILKINSON VIGILANCE TASK

As described in section 4.2 the Wilkinson vigilance task is an audio task for which subjects are asked to listen to notes, transmitted to them at two-second intervals, against a background of what is approximately white noise. The normal notes are of about 500ms duration, but occasionally one of 400ms duration is substituted. This occurs on average once every 1½min and subjects are asked to respond by pressing buttons on a box as described in section 4.2.

The task was transmitted to the subjects from a tape recorder. It was noticeable that variations occurred in frequency content and volume of the signal; the latter could, however, be corrected within the equipment used. It is apparent that other factors may also affect what the subjects actually hear, for example, the response characteristics of the tape recorder, intercom system and headphones will all contribute to an overall modification of the signal before it reaches the subject. It was therefore decided to measure and analyse the signal received by each ear of two subjects, one in each seat.

For these measurements a Knowles miniature microphone type 1670 was connected to a Nagra single-channel tape recorder, with a power pack and a Bruel and Kjaer sound level meter. The microphone was fitted into each of the ears of each subject in turn, while the subjects listened to the task. All conditions in the chamber were as for the no-vibration sessions, i.e. the rig hydraulic system was running but the seats were stationary. After the recordings had been made a further recording was made of the noise in the left ear of each subject with the task switched off. The recordings were then replayed into a Bruel and Kjaer Real Time Analyser, which measured the amplitude levels in 1/3 octave bands between 125Hz and 4KHz. These have been plotted in Fig.21 as dB levels against frequency.

It can be seen from Fig.21 that three of the recordings with the task on are very similar but one is different. This would suggest that subject II did not have the headphone positioned correctly over his left ear. This is substantiated by the task-off recordings, since the level in the left ear of subject II is shown much higher, suggesting a leak of chamber noise into the ear. This is, however, a possible situation during the tests, and the analysis therefore gives a general picture of what subjects probably hear.

The dB levels recorded where the short notes occur can be seen at 630Hz, and are arrowed.

Appendix B

TRACKING TASK

The task has been used in a similar form for a number of years by BAC, Bristol and RAE.

The measurement of task proficiency has been obtained by a mean-error method. The equipment, as described, supplies single-axis tasks for two subjects simultaneously, although it is normally used as a two-axis task for one subject.

The tasks are generated by applying signals to the y plates of two oscilloscopes.

The y signal is the function

$$y = \sin \frac{\pi t}{10} - \left(\sin \frac{11\pi t}{30} + \cos \frac{11\pi t}{30} \right)$$

The x signal is the function

$$x = \sin \frac{\pi t}{10} + \cos \frac{\pi t}{10} + \cos \frac{11\pi t}{30}$$

These two functions are obtained by mixing the outputs obtained from two oscillators, one at a frequency of 0.05Hz and one at 0.18Hz.

Circuit diagram for oscillators

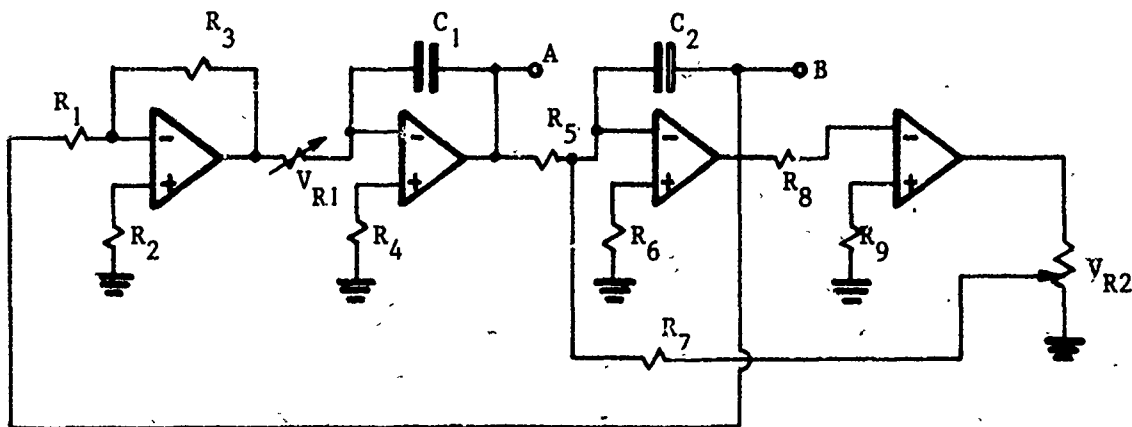

Component values for:-

0.05Hz oscillator

- $R_1 = 12k\Omega$
- $R_2 = 5.6k\Omega$
- $R_3 = 12k\Omega$
- $R_4 = 220k\Omega$
- $R_5 = 220k\Omega$
- $R_6 = 220k\Omega$
- $R_7 = 470k\Omega$
- $R_8 = 12k\Omega$
- $R_9 = 12k\Omega$
- $V_{R1} = 500k\Omega$
- $V_{R2} = 5k\Omega$
- $C_1 = 8.2\mu F$
- $C_2 = 8.2\mu F$

0.18Hz oscillator

- $R_1 = 12k\Omega$
- $R_2 = 5.6k\Omega$
- $R_3 = 12k\Omega$
- $R_4 = 82k\Omega$
- $R_5 = 82k\Omega$
- $R_6 = 82k\Omega$
- $R_7 = 470k\Omega$
- $R_8 = 12k\Omega$
- $R_9 = 12k\Omega$
- $V_{R1} = 500k\Omega$
- $V_{R2} = 5k\Omega$
- $C_1 = 8.2\mu F$
- $C_2 = 8.2\mu F$

x-task generator

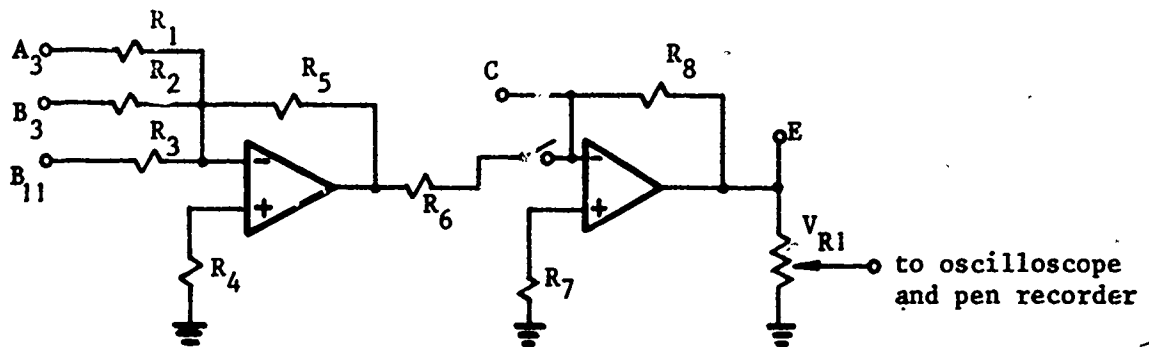

- $R_1 = 330k\Omega$
- $R_2 = 470k\Omega$
- $R_3 = 390k\Omega$
- $R_4 = 220k\Omega$
- $R_5 = 470k\Omega$
- $R_6 = 470k\Omega$
- $R_7 = 330k\Omega$
- $R_8 = 1M\Omega$
- $V_{R1} = 1M\Omega$

The suffix 3 on the input connections signifies output of 0.05Hz oscillator, and suffix 11 the output from the 0.18Hz oscillator. The potentiometer V_{R1} gives the scaling to suit the oscilloscope screen.

y-task generator

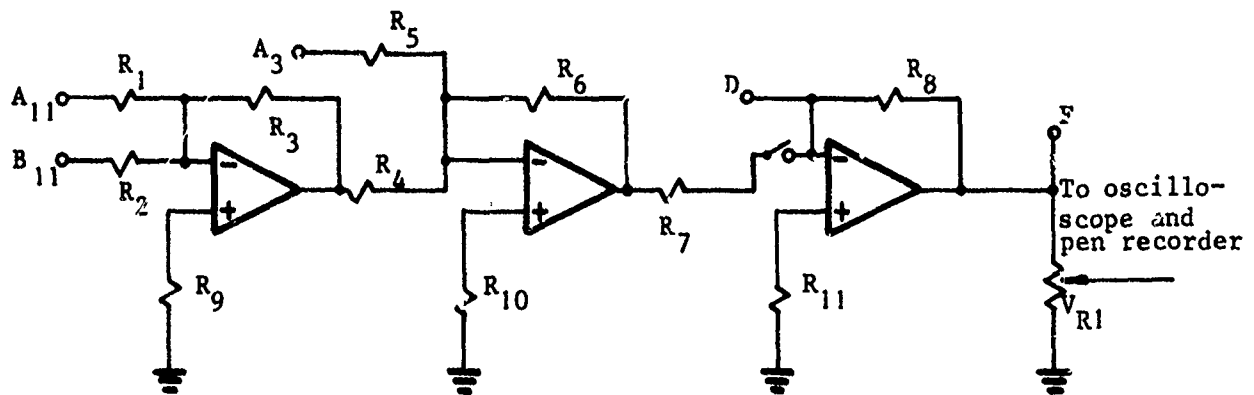

- $R_1 = 390k\Omega$
- $R_2 = 390k\Omega$
- $R_3 = 470k\Omega$
- $R_4 = 470k\Omega$
- $R_5 = 330k\Omega$
- $R_6 = 470k\Omega$
- $R_7 = 470k\Omega$
- $R_8 = 1M\Omega$
- $R_9 = 220k\Omega$
- $R_{10} = 220k\Omega$
- $R_{11} = 330k\Omega$
- $V_{R1} = 1M\Omega$

As for the x-task generator the suffices 3 and 11 on the input connections signify connections to the 0.05Hz and 0.18Hz oscillators respectively. The potentiometer V_{R1} again gives the scaling to suit the oscilloscope screen.

Control stick circuit

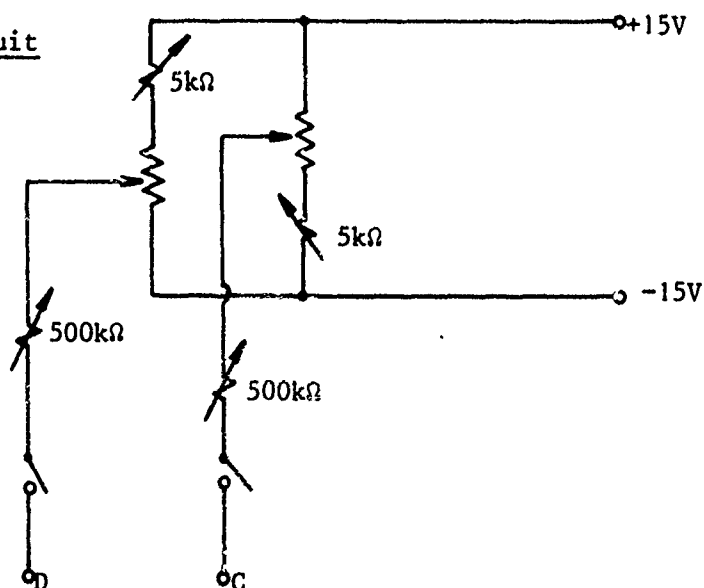

The $5k\Omega$ potentiometer facilitates the centralization of the line on the screen (i.e. zero voltage) with no deflection on the stick, and should not normally require further adjustment after initial setting up. The $500k\Omega$ potentiometer provides scaling adjustment of the line deflection to suit the oscilloscope.

Mean error measurement

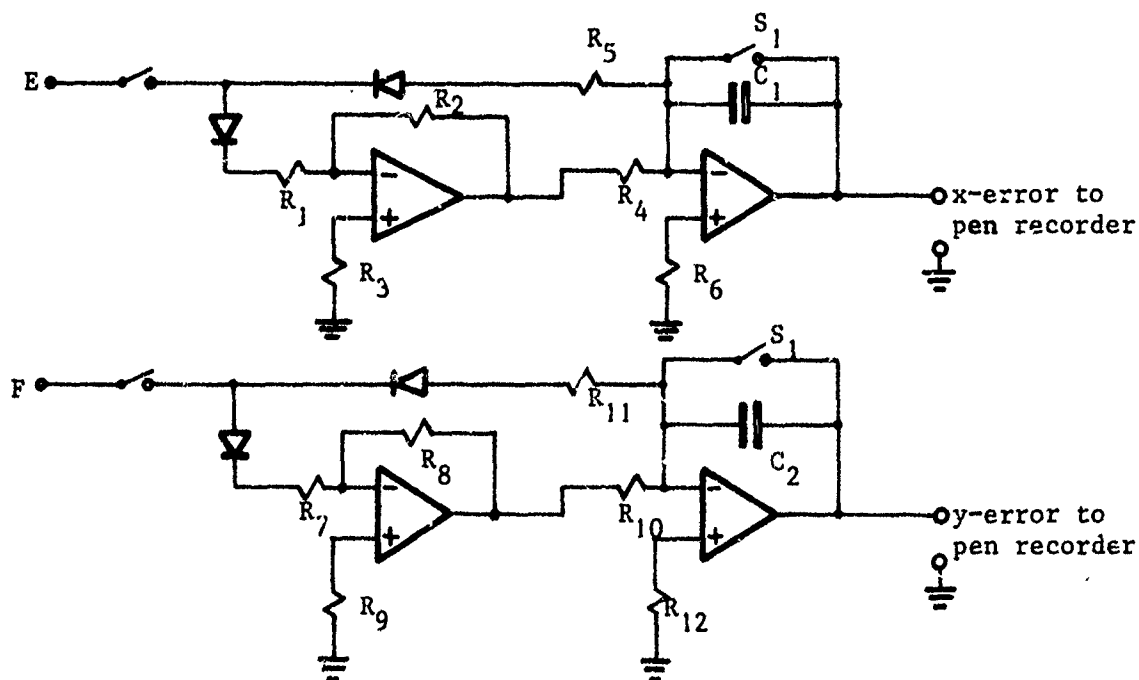

$$R_1 = R_7 = 1M\Omega$$

$$R_2 = R_8 = 1M\Omega$$

$$R_3 = R_9 = 470k\Omega$$

$$R_4 = R_{10} = 2.2M\Omega$$

$$R_5 = R_{11} = 2.2M\Omega$$

$$R_6 = R_{12} = 820k\Omega$$

$$C_1 = C_2 = 10\mu F$$

Switch S_1 is a push-ON, release-OFF double pole push button switch and provides the reset for the error circuits.

Construction

The circuits are constructed on two sheets of 2.54mm matrix double-sided veroboard. All the integrated circuits used are 14 pin dual-in-line encapsulated devices, and are mounted in holders to facilitate easy removal, if this should be necessary. The two oscillators and task generators are all mounted on one board, and the mean error measurement circuit is mounted on the other. This leaves sufficient room on the error board to construct a mean square error circuit if this is desired.

Setting up

The two oscillators require very careful setting up, but once adjusted it should not be necessary to make any further adjustment. The $500k\Omega$ variable resistors, V_{R1} , provide frequency adjustment and the $5k\Omega$ variable resistors are quite precise in their settings. The output from point B should be monitored on an oscilloscope; if V_{R2} is set too low, the output will be in the form of a damped oscillation and if set too high, the output will show serious distortion. A setting between these two limits for V_{R2} will give a satisfactory output.

Integrated circuits

All the integrated circuits used are 741 series operational amplifiers. These operate from a +15V, 0, -15V power supply. They are 14 pin dual-in-line encapsulated components and the relevant pin connections are:-

Pin 4	Inverting input
Pin 5	Non-inverting input
Pin 6	$V_{cc} -$
Pin 10	Output
Pin 11	$V_{cc} +$

Operation

The only additional equipment required are the two oscilloscopes to display the task and a four track pen recorder for the trace record and error scores. Alternatively the error score could be recorded on a voltmeter.

The output terminals on the unit provide for leads to be taken to the two oscilloscopes and pen recorder inputs. The red terminals denote signal leads and the black terminals are signal earth leads. The NATO 4-way jack socket provide the terminal connections to the two control sticks; terminals 1 and 2 for task x and terminals 3 and 4 for task y. The one terminal facilitates a simple conversion to a single two-axis task.

The unit has a very large time constant in the circuits; it is therefore necessary to allow five minutes after switching on before any adjustments are made. The unit generates voltages of the order of 12 volts peak-to-peak and in order to accommodate this the oscilloscope attenuators should be set to 1V/cm.

With the task ON and stick OFF the two task scaling potentiometers can be adjusted so that the task covers the desired area of the oscilloscope screens.

With the task OFF and stick ON the two stick scaling potentiometers can be adjusted so that full deflection of the sticks gives the desired deflection of the line on the oscilloscope.

In order to make an error measurement, the error switch is first turned on and the subjects start tracking. The RE-SET button is pressed and then released, when the timed period is begun. After the required time the error switch can be turned OFF, when the error scored by each subject will be stored until the RE-SET button is pressed again.

Mean-square error

In order to measure the mean-square error, it is necessary to square the error signals obtained at points E and F and then to integrate them. The squaring functions may be obtained in several ways, the easiest being to use a commercially available squaring module, for example an Ancom Ltd. squaring module type 15SN-1 or type 15SP-1. These operate directly into the summing junction of an operational amplifier and produce a current output proportional to the signal of the input voltage.

Task dimensions

With a subject seated in the normal position for the tracking task the following measurements were made:-

full scale deflection of CRT	60mm
distance of CRT from subject's eye	450mm
total possible angular movement of control stick	$60^\circ (\pi/3\text{rad})$
scale of CRT	0.1V/mm
maximum difference in control stick output	25V

Hence for 1V on the CRT, the angle subtended at the eye is $(10/450)\text{rad}$ and the movement of the stick is $(\pi/3)/25 = \pi/75\text{rad}$.

Therefore the control/display ratio is $(45\pi/75) = 1.88$.

Table 1
SUBJECT DETAILS

Subject	Age	Height	Weight
	(years)	(m)	(kg)
a	19	1.69	54.0
b	21	1.79	73.0
c	24	1.83	66.2
d	23	1.68	72.1
e	32	1.80	82.5
f	37	1.79	85.3
g	36	1.83	71.7
h	35	1.76	63.5
k	17	1.73	64.9

Table 2a
AUDIO/VISUAL MEASUREMENTS

Subject a

Condition			Day 1		Day 2		Day 3		Day 4	
			NV/K		V/NK		V/K		NV/NK	
			pre	post	pre	post	pre	post	pre	post
Threshold of hearing (dB)	R	500Hz	10	10	10	10	5	5	10	10
		4kHz	10	10	10	10	10	10	5	10
	L	500Hz	10	15	5	10	5	10	5	5
		4kHz	10	10	10	10	5	10	10	10
Reading chart	Chart No.		1	2	3	4	5	6	1	2
	Right eye		7	7	7	7	7	7	7	7
	Left eye		7	7	7	7	7	7	7	7
Near point rule (mm x 10)	Near point		16	18	15	16	16	16	14	14
	Acc. point		6	10	7	7	8	8	7	8
Maddox wing	Red scale		0	0	0	0	0	0	0	0
	White scale		0	0	0	2	0	2	2	2

Table 2d

AUDIO/VISUAL MEASUREMENTSSubject d

Condition			Day 1		Day 2		Day 3		Day 4	
			V/NK		NV/K		NV/NK		V/K	
			pre	post	pre	post	pre	post	pre	post
Threshold of hearing (dB)	R	500Hz	0	5	-5	10	-5	15	0	5
		4kHz	-5	10	0	20	0	15	0	5
	L	500Hz	0	5	0	10	5	10	0	10
		4kHz	15	20	15	20	15	20	20	15
Reading chart	Chart No.		4	5	6	1	2	3	4	5
	Right eye		7	7	7	7	7	7	7	7
	Left eye		7	7	7	7	7	7	7	7
Near point rule (mm × 10)	Near point		14	18	12	18	16	16	20	26
	Acc. point		6	6	6	6	6	6	6	6
Maddox wing	Red scale		0	0	0	0	0	0	2	2
	White scale		6	4	2	1	4	2	2	4

Table 2e

AUDIO/VISUAL MEASUREMENTSSubject e

Condition			Day 1		Day 2		Day 3		Day 4	
			NV/NK		V/K		V/NK		NV/K	
			pre	post	pre	post	pre	post	pre	post
Threshold of hearing (dB)	R	500Hz	25	30	25	30	30	25	25	30
		4kHz	20	25	25	25	25	25	25	20
	L	500Hz	10	10	10	15	10	5	10	10
		4kHz	10	20	15	15	10	15	5	10
Reading chart	Chart No.		1	2	3	4	5	6	1	2
	Right eye		6	7	6	7	7	7	7	7
	Left eye		7	7	7	7	7	6	7	7
Near point rule (mm × 10)	Near point		18	18	13	17	18	21	20	20
	Acc. point		6	6	6	6	6	6	6	6
Maddox wing	Red scale		0	0	0	0	0	0	0	0
	White scale		1	0	0	0	0	0	0	0

Table 2f

AUDIO/VISUAL MEASUREMENTSSubject f

Condition			Day 1		Day 2		Day 3		Day 4	
			NV/NK		V/K		V/NK		NV/K	
			pre	post	pre	post	pre	post	pre	post
Threshold of hearing (dB)	R	500Hz	15	10	10	10	15	15	10	10
		4kHz	15	15	15	20	10	20	10	20
	L	500Hz	15	10	15	10	15	10	15	15
		4kHz	15	15	10	15	5	10	10	15
Reading chart	Chart No.		4	5	6	1	2	3	4	5
	Right eye		7	7	6	7	7	7	7	7
	Left eye		7	6	6	7	7	7	6	7
Near point rule (mm x 10)	Near point		11	11	11	10	9	8	7	7
	Acc. point		9	11	6	6	6	6	6	6
Maddox wing	Red scale		0	0	0	0	0	0	0	0
	White scale		2	2	2	2	2	2	2	2

Table 2g

AUDIO/VISUAL MEASUREMENTSSubject g

Condition			Day 1		Day 2		Day 3		Day 4	
			V/K		NV/NK		NV/K		V/NK	
			pre	post	pre	post	pre	post	pre	post
Threshold of hearing (dB)	R	500Hz	10	15	10	15	5	5	10	10
		4kHz	25	20	25	20	15	20	15	25
	L	500Hz	5	15	10	15	15	15	10	10
		4kHz	25	30	35	30	30	30	25	30
Reading chart	Chart No.		1	2	3	4	5	6	1	2
	Right eye		6	7	7	7	7	7	7	7
	Left eye		7	7	7	7	7	7	7	7
Near point rule (mm x 10)	Near point		20	23	19	24	21	20	25	25
	Acc. point		9	12	13	15	13	13	18	15
Maddox wing	Red scale		0	0	0	0	0	0	0	0
	White scale		1	0	1	1	2	1	1	0

Table 2h

AUDIO/VISUAL MEASUREMENTSSubject h

Condition		Day 1		Day 2		Day 3		Day 4		
		V/K		NV/NK		NV/K		V/NK		
		pre	post	pre	post	pre	post	pre	post	
Threshold of hearing (dB)	R	500Hz 4kHz	15 5	15 10	15 10	15 10	10 5	10 5	20 10	25 15
	L	500Hz 4kHz	10 10	10 10	15 10	15 10	15 10	10 10	10 15	15 10
Reading chart	Chart No.		4	5	6	1	2	3	4	5
	Right eye		6	7	6	7	7	7	7	7
	Left eye		6	7	6	7	7	7	6	6
Near point rule (mm × 10)	Near point		18	20	20	19	19	20	19	19
	Acc. point		8	10	12	12	14	12	12	12
Maddox wing	Red scale		0	0	0	0	0	0	0	0
	White scale		8	6	8	4	4	4	4	4

Table 3

TASK SCORESSubject a

Condition		Day 1	Day 2	Day 3	Day 4
		NV/K	V/NK	V/K	NV/NK
Tracking (error scored)	1	3.6	3.6	4.0	3.1
	2	3.4	4.6	3.9	3.2
	3	3.1	4.1	3.4	3.2
	4	2.9	3.5	3.1	3.0
	5	2.7	3.2	3.2	3.2
	6	3.0	3.2	3.3	3.0
Writing	1	10	8	7	10
	2	10	6	6	10
	3	9	7	7	10
Search (targets found)	1	6	4	18	19
	2	15	12	4	18
	3	16	17	9	19
Vigilance 1 (signals detected) per quarter hour	1/4	7	6	7	8
	1/2	4	3	5	8
	3/4	5	4	4	5
	4/4	2	2	4	1
Vigilance 2 (signals detected) per quarter hour	1/4	3	4	8	7
	1/2	2	3	6	5
	3/4	6	4	4	3
	4/4	3	8	1	7

Table 3b

TASK SCORESSubject b

Condition		Day 1	Day 2	Day 3	Day 4
		NV/K	V/NK	V/K	NV/NK
Tracking	1	4.4	5.3	4.1	3.9
	2	3.5	5.2	4.0	3.2
	3	4.7	5.2	5.5	3.3
	4	3.7	4.6	3.8	3.4
	5	3.7	5.0	3.7	4.6
	6	3.7	4.6	3.8	3.8
Writing	1	8	3	4	7
	2	7	2	4	7
	3	7	1	3	6
Search	1	9	2	11	13
	2	4	19	15	3
	3	9	18	10	14
Vigilance 1	1/4	6	8	9	8
	1/2	6	4	6	5
	3/4	5	4	6	4
	4/4	4	3	6	3
Vigilance 2	1/4	4	5	8	7
	1/2	6	4	3	2
	3/4	4	2	5	2
	4/4	3	4	3	2

Table 3c

TASK SCORESSubject c

Condition		Day 1	Day 2	Day 3	Day 4
		V/NK	NV/K	NV/NK	V/K
Tracking	1	3.9	2.4	2.8	3.2
	2	3.4	2.2	2.1	2.6
	3	3.2	2.4	2.2	2.4
	4	3.4	2.2	2.4	2.2
	5	3.4	2.3	2.8	2.9
	6	3.4	2.2	2.6	2.7
Writing	1	5	9	10	7
	2	~	10	10	7
	3	4	10	9	5
Search	1	21	17	25	10
	2	8	13	13	9
	3	9	17	24	28
Vigilance 1	1/4	5	6	7	6
	1/2	6	6	5	5
	3/4	4	1	7	7
	4/4	6	4	5	3
Vigilance 2	1/4	5	7	7	5
	1/2	6	7	3	4
	3/4	5	5	6	5
	4/4	5	4	4	6

Table 3d

TASK SCORESSubject d

Condition		Day 1	Day 2	Day 3	Day 4
		V/NK	NV/K	NV/NK	V/K
Tracking	1	4.1	2.9	3.0	3.4
	2	3.4	3.0	2.4	4.0
	3	4.0	3.1	3.1	3.5
	4	3.4	3.6	2.6	3.4
	5	4.0	3.2	3.2	3.8
	6	4.2	2.6	2.2	3.4
Writing	1	7	10	9	8
	2	5	10	10	6
	3	5	10	9	6
Search	1	8	13	9	4
	2	4	8	13	13
	3	12	9	18	18
Vigilance 1	1/4	9	7	9	10
	1/2	7	8	8	8
	3/4	4	4	7	8
	4/4	6	8	7	8
Vigilance 2	1/4	10	5	8	6
	1/2	4	3	10	6
	3/4	6	7	9	4
	4/4	8	5	5	7

Table 3e

TASK SCORESSubject e

Condition		Day 1	Day 2	Day 3	Day 4
		NV/NK	V/K	V/NK	NV/K
Tracking	1	1.8	2.2	2.0	1.8
	2	1.8	2.2	2.0	1.6
	3	1.7	2.0	2.0	1.7
	4	1.8	1.9	1.9	1.6
	5	1.9	1.8	1.9	1.6
	6	1.8	1.9	2.6	1.6
Writing	1	10	9	6	10
	2	10	7	7	9
	3	9	7	7	9
Search	1	4	7	4	20
	2	4	17	9	9
	3	12	9	16	18
Vigilance 1	1/4	8	8	10	10
	1/2	6	7	8	7
	3/4	3	6	8	5
	4/4	6	6	6	5
Vigilance 2	1/4	7	7	8	9
	1/2	6	6	4	6
	3/4	2	4	6	5
	4/4	1	4	4	8

Table 3f

TASK SCORESSubject f

Condition		Day 1	Day 2	Day 3	Day 4
		NV/NK	V/K	V/NK	NV/K
Tracking	1	4.4	5.2	5.1	4.0
	2	4.6	8.4	7.5	5.5
	3	4.2	5.0	4.7	4.5
	4	5.0	4.1	4.8	3.9
	5	4.6	4.4	4.2	3.9
	6	3.8	4.0	4.6	3.4
Writing	1	10	6	5	10
	2	9	5	4	8
	3	8	4	5	9
Search	1	14	8	15	9
	2	9	14	9	26
	3	16	8	14	18
Vigilance 1	1/4	7	4	3	3
	1/2	7	5	4	6
	3/4	6	6	4	4
	4/4	4	3	2	5
Vigilance 2	1/4	6	9	4	6
	1/2	2	6	2	2
	3/4	3	3	1	6
	4/4	2	5	2	4

Table 3g

TASK SCORESSubject g

Condition		Day 1	Day 2	Day 3	Day 4
		V/K	NV/NK	NV/K	V/NK
Tracking	1	3.2	2.1	2.7	3.5
	2	2.8	2.3	2.2	2.9
	3	2.8	2.6	2.2	2.8
	4	2.6	2.2	2.2	2.6
	5	3.4	2.6	2.4	3.0
	6	2.9	2.6	2.2	2.6
Writing	1	4	10	10	5
	2	6	9	9	5
	3	5	8	8	6
Search	1	18	14	13	28
	2	9	11	18	15
	3	14	19	14	23
Vigilance 1	1/4	7	8	8	10
	1/2	9	1	7	10
	3/4	5	6	9	4
	4/4	5	4	7	2
Vigilance 2	1/4	10	5	9	9
	1/2	7	2	8	8
	3/4	4	0	7	8
	4/4	5	2	10	7

Table 3h

TASK SCORESsubject h

Condition		Day 1	Day 2	Day 3	Day 4
		V/K	NV/NK	NV/K	V/NK
Tracking	1	4.8	3.2	3.0	4.2
	2	3.8	3.0	2.9	3.6
	3	3.8	3.0	3.0	3.3
	4	3.5	3.0	3.0	3.4
	5	3.6	2.8	2.8	3.5
	6	4.1	2.9	3.1	4.0
Writing	1	8	10	10	8
	2	8	9	10	7
	3	7	9	9	7
Search	1	9	15	4	8
	2	10	9	19	7
	3	8	5	9	16
Vigilance 1	1/4	10	10	10	10
	1/2	7	10	10	10
	3/4	8	8	8	6
	4/4	9	7	6	7
Vigilance 2	1/4	8	7	10	9
	1/2	6	6	9	8
	3/4	6	7	9	6
	4/4	5	5	9	10

REFERENCES

- | <u>No.</u> | <u>Author</u> | <u>Title, etc.</u> |
|------------|--|--|
| 1 | International
Organization for
Standardization | Guide for the evaluation of human exposure to whole-
body vibration.
International Standard ISO 2631 (1974) |
| 2 | K.R. Maslen | Efficiency under prolonged vibration and the ISO 'Guide'.
Unpublished RAE Technical Memorandum (1972) |
| 3 | M.D. Bennett
B. Farmilo
M.A.C. Campbell | Human response to vibration in military cross country
vehicles; the effect of frequency and duration of
exposure in a simulated environment.
Royal Military College of Science,
Technical Note AM/64, December 1974 |
| 4 | R.T. Wilkinson | Methods for research on sleep deprivation and sleep
functions.
Int. Psychiat. Clin., <u>7</u> , 369-382 (1970) |
| 5 | G.F. Rowlands | Brief report on the commissioning trials of the Servo-
Consultants 2-axis vibration rig in R132 Building at
RAE Farnborough.
Paper given at meeting of UK informal vibration group at
Swansea University, January 1972 |
| 6 | P. Branton | Seating in Industry.
Ministry of Technology - Ergonomics for Industry No.10,
June, 1966.
HMSO 161062 |
| 7 | C.B. Bolton | Ventile, incompressible cushion.
Applied Ergonomics, 3.2, 101-105 (1972) |
| 8 | Sidney Siegel | Nonparametric statistics for the behavioural sciences.
McGraw-Hill Book Company, Inc., pp.75-83 (1969) |
| 9 | British Standards
Institution | Guide to the evaluation of human exposure to whole-body
vibration.
BSI Draft for Development DD32 (1974) |

Fig. 1

TR 760/J1

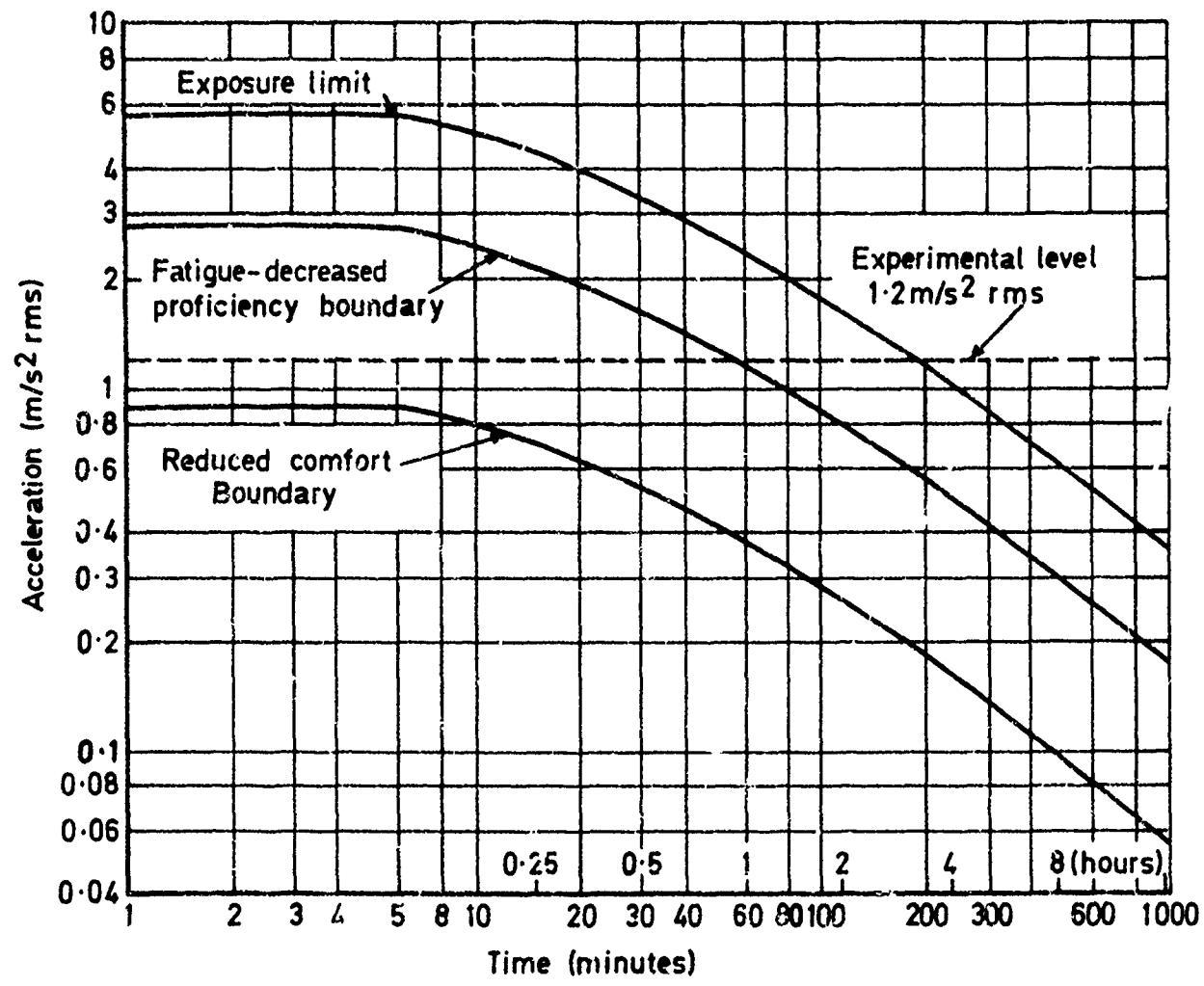

Fig.1 ISO limits for vertical vibration at 5Hz

Fig.2

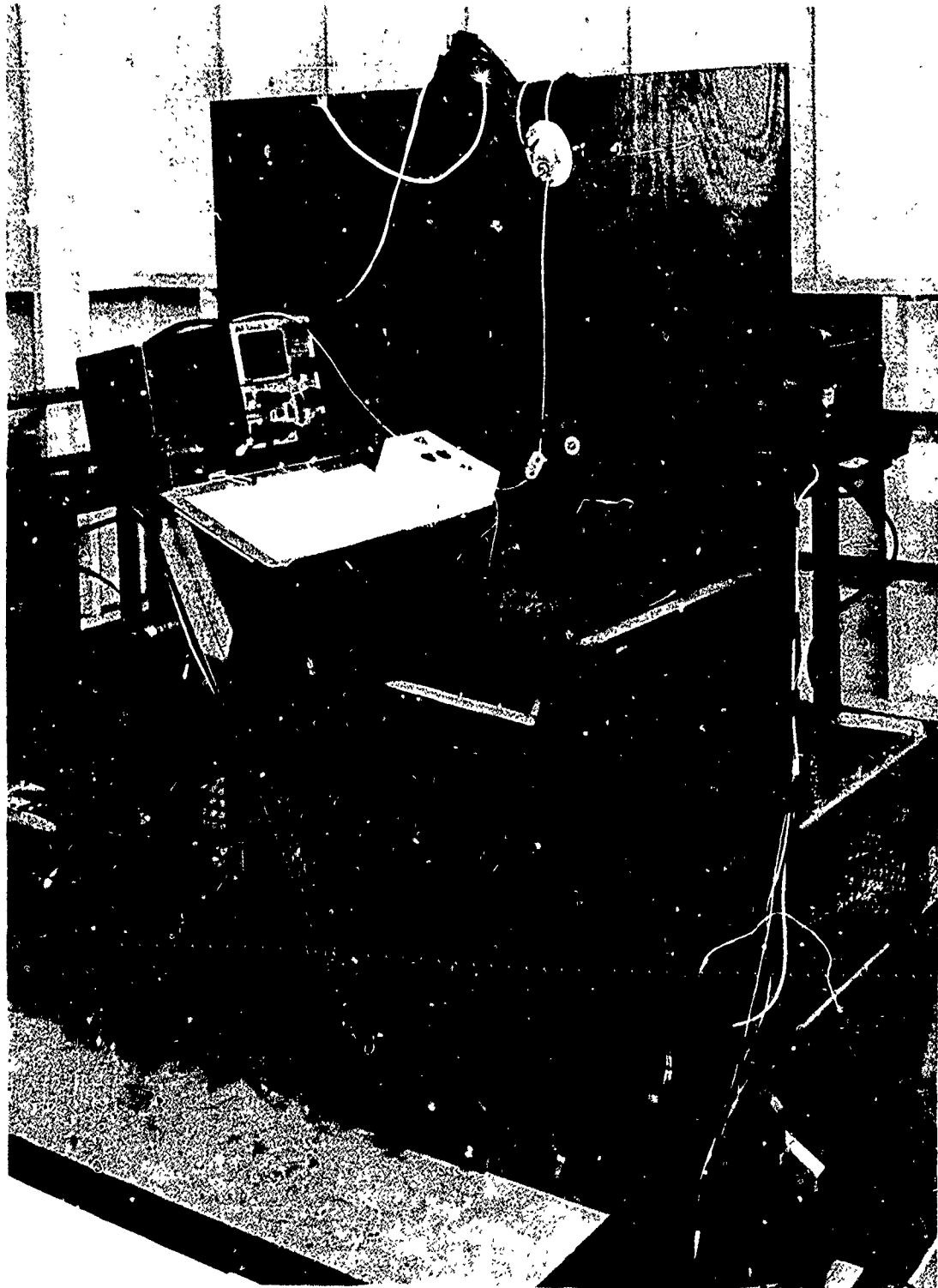

Fig.2 Seat and equipment

Fig.3



Fig.3 Subjects performing tracking task

Fig.4

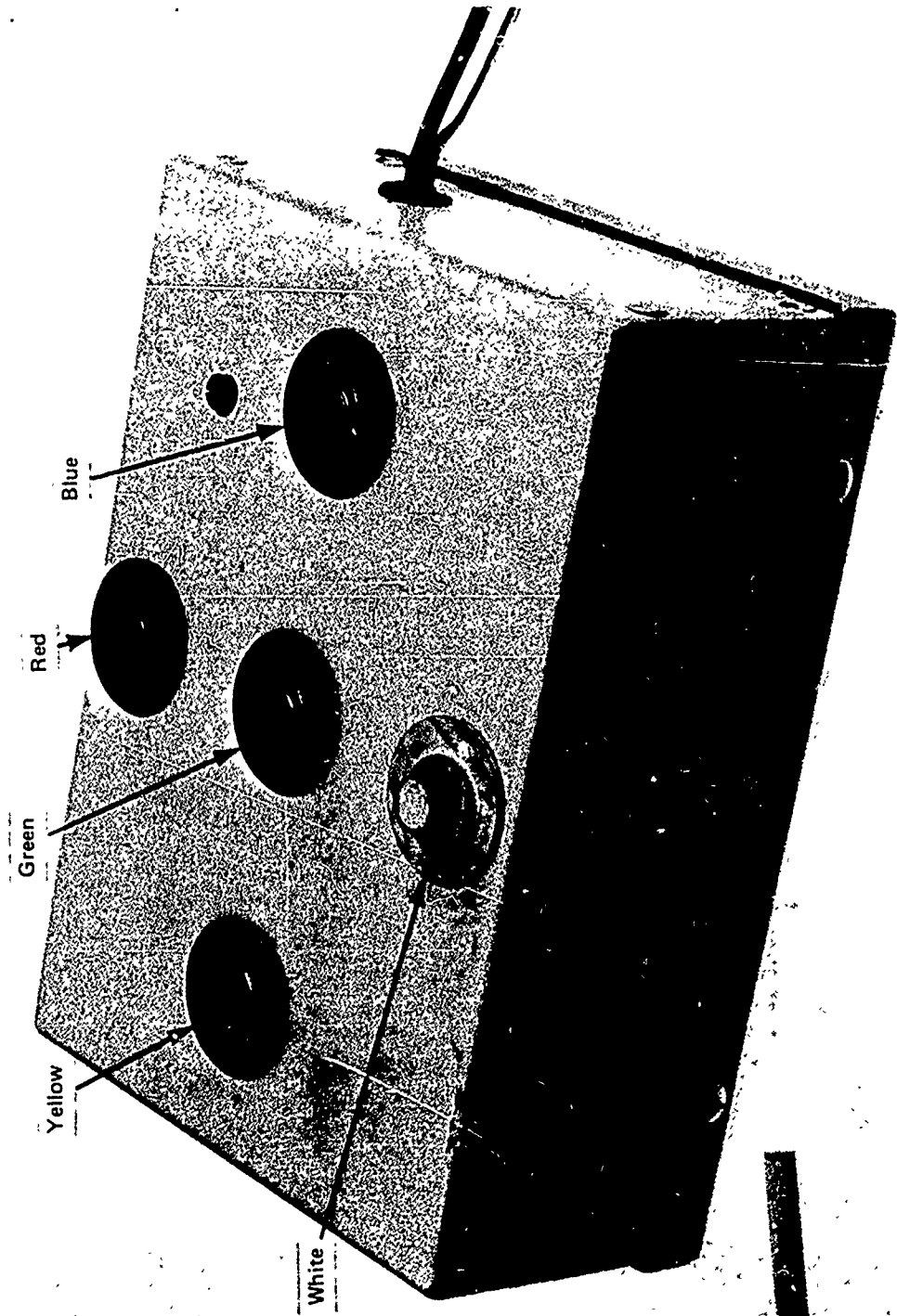

Fig.4 Response box

Fig.5

S

THLKPIIXVTIINGGVUPNCKR KTRXBP CBBXVXYRCNYPYBRHKVXKFCYK
 XNYGLYXFCWHRBOHVYFBTBGKNGFG3XRLYPBHUCUF TXGOKPURFKV
 HHEKUPKVXGLTRVHFGRFCNXVFTKVFY TBUHTVVC LTGF XCPBHVKLN
 RGPXF TNUXGRCHRPYLFNNYUUF3NY TBVLLTP LUKFUHAXYZLLGYUG
 PCHUKGRTHVYVVRHXUXGNUMXC LBCCUTR KHTUBVGVHF KNCULXKMVT
 3LYFXHCVPYVHKUY TRNULGUCVRUCXKG VGYKF TCF CHYYPBUBCTBK
 HSTUUYNTKFBGCTYTKYVCNLTLDNLLRNCHVBHNF PGKNNTPGRCUX
 FLRTTVTGTXLUGCBULF VUF3FRHXNVYFR VCYVUKKF BPPBP KRFPN
 FURVHPV KPHPCY3PP TGF PVHCHKU XP VKNRF LGBNKRNR LBP KCCXF
 NCRUKKCA XBYGHNYGCPBLLK3YKKBH LXCBBXLY NRF CBXRB LUF3PF
 KUMNRF LUTHVCLUR LUCGHFCY GKGCLM3 KXBFHPUPBVHG LBCYXPTH
 FGHVGRGCGP PCXVXCGF LXL YRRJUUKR3KB VHXHVRPPUVHTCRGG
 CVURPXNUVNPRPYPF LHV DQKYHVUF FULTTNYKFYKLXY HKR3BRNR
 GCGCXUF VURGHX3NTXHD X3HHKGF BUBUHYF TNRBPGTKBGUPRCX PY
 RYUTCGLSF XPTPLKULFGDLYVGF K3BNPNFRUUKLLTR XTBRKXKX
 RBTXTXRYVTPYXVX XFPKGK LGPRYPYRPS LYHBU TRCNGTRTFUVN
 YTXGUUK3TRR LKRPYRGPCPYR XLE LNHHC3B3BC LFYBF3TUTBKLUY
 HYXKXKBNGFPCGGF TBGRNHBP KRHKCXVXF HRP TKNPRGCKPRTYR XT
 FVX3XURFGXYUGXHV LXHRF PULY LCGNP VULR TXF TTXTHUYUTTFPX
 HTCHNHHC3R VWKHUPVKHUG3 LNX YHR KFBKYNF TUUPCPRPNCTUBUL
 LLHVXCRPCTGLXHLPGFKHP XCYXCCUPS LULVFRSHNV LFFF TRHCY3
 NMCRVFC LYBYGHYPNNNXCT LFVFXGHYUVNUPR LHV LGUPX3BNNLH
 UPSYKGRBXUCFY LUHTPYXRCTYBNGGY LX XFHGGCUULX3CYVFBPCV
 RUVYLXCCFXN3CHKF TVCGCXYPBNHRN3R LTXBPBLCVKPEXRFNHL
 RLVRFTVUSHYRGNGP XCCURHGBTGPTCRGCC LNBQVLHGNTCP LGVCT
 NKUYVNXVYUYN TKCHF3YUTX TYY TLGYNB3 NNHRCKHLVPCNGTFC
 RVHUPUTHPYUXYZYFHRUBHCNGX XNKB LLKNF HNYKX3BHYHCTGRVL
 FHLSTN3TKGTVJFXTGNGVLRNFRNKB3TH XDFYHHF PBXF TFVWVY
 LVXAKFVHB TYBFHTULLCRPPY VGUCYNNKF YBLCNXGNXCRVUTVCK
 RVFGLTKPRXBRYK3VTKULB LTKXFFXGUTP LNHGHP XTVPYUCBUVXR
 CKRGYUBNUVPKH YFKBRYUCTUGTVHUKFFPCNG LBGHLN3LVCCVTNC
 TTMYVPNNG TLLPTDNBRUBLCVNNBULTTKKY Z3LPLP VTCNFAYGHNU
 RVVKN3TYRTGTHHF LXBHLVKYBGRPRP LXF CVLF KHBKULFYNF CVWCH
 N3LVUYXKT3G3YJLFPBPUGOFVKNRHFYUYPYXVGCUXNF TULGK3CXH
 FPHNRPV3NKTUCPGYKR T3TXVGVJHUXXVYYLULBKNLBE THXVXNNY
 XUTVFFLULPRCLFNFUG3X3CTVXUKF LKRCRLLVKBYVXPKUTFTHR
 YXFXP3GLBYNFHHLHRGHXRKLKXTTUBGCGGVVHVKBYKPKGNYBPX
 TUUYUNTXGYRFKHFNLKRFVUFGF3BUXHGPKPPNF VBGUYCTR3NN
 VPKGCLKZB3CF3KHTFVYNVXVR XLRVVOPTFYFRKTFRBUY3ULH
 XL3HULPRTFVUVHPTGXLPYUVTAKF TGFUCUGRURFPRPYPHFPCCKU
 FYLUKCBXKYCCLBCNYVVVPRKX TLUTTLHPKLPYLTBKGRHPPTFVVV
 JNRNVLFPRUKYTRNUKKNF NYQGNNBR YRKN3NYNHRXVROCPXYGNN
 UYXYVGC3NRFCTUBCYPT3THFF LYTCVV3NX3LGNP LFRGBKFRKPP
 CN3KGYBWK3R3UNHCYFHYRCHK3BYR3VXF3LLPBHYB3GRVCTLRP
 HCGYPTHTTGCHB3CVFNFK3R3PUVLPGBYTLTTBKY TGLTHPR3CRY
 KBKYGYBGYKHUUCTLHHNTYCPVKT3LVGHXPRB3GUHNKUKCPHBPY3
 GCUCGDUXPPVYNB3NFNGK3YR3KTKLNV3VVEKRHKVHKPHPLK3XUYH
 LB3NFNRKCHGGV3NHG3VLR3CCTTYLFHNXHB L3KYNNB3XKUTNT3F
 YRFLCHR3HHP3CP3C3RYVHY3TKCFXUVGYJHXUXR3PYVLH3RTRPNN
 PNUY3CGT33GKUF3VPLR3K3CXNGFNNLHGUG3BRHUXFHCFNUF3UBK

Fig.5 Example of search task

Fig.6

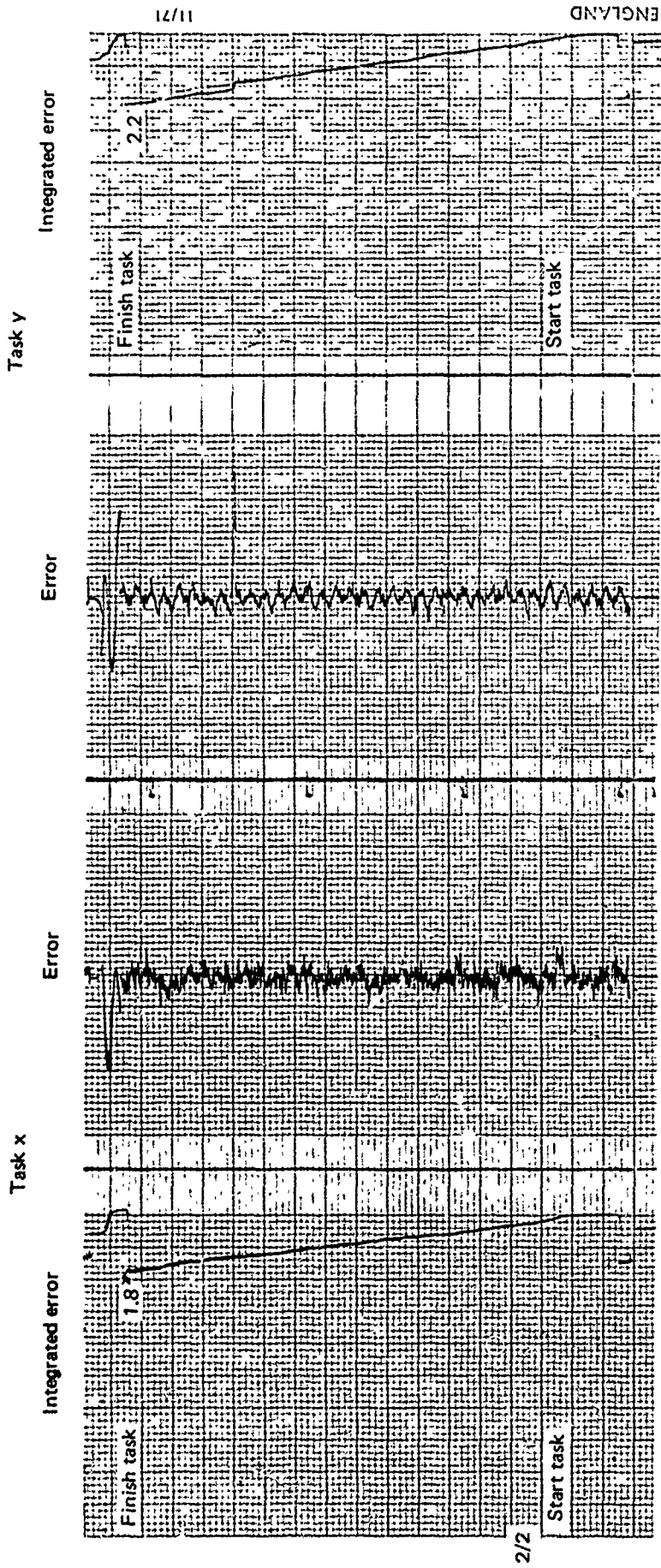

Fig.6 Example of tracking task record

Fig.7

DATE	4th August 1973
TIME	11-15 a.m.
CONDITION	No vibration
SEAT	II
NAME	A. Subject
SIGNATURE	A. Subject

TR 76011

Fig.7 Example of writing task attached to desk

Fig. 8

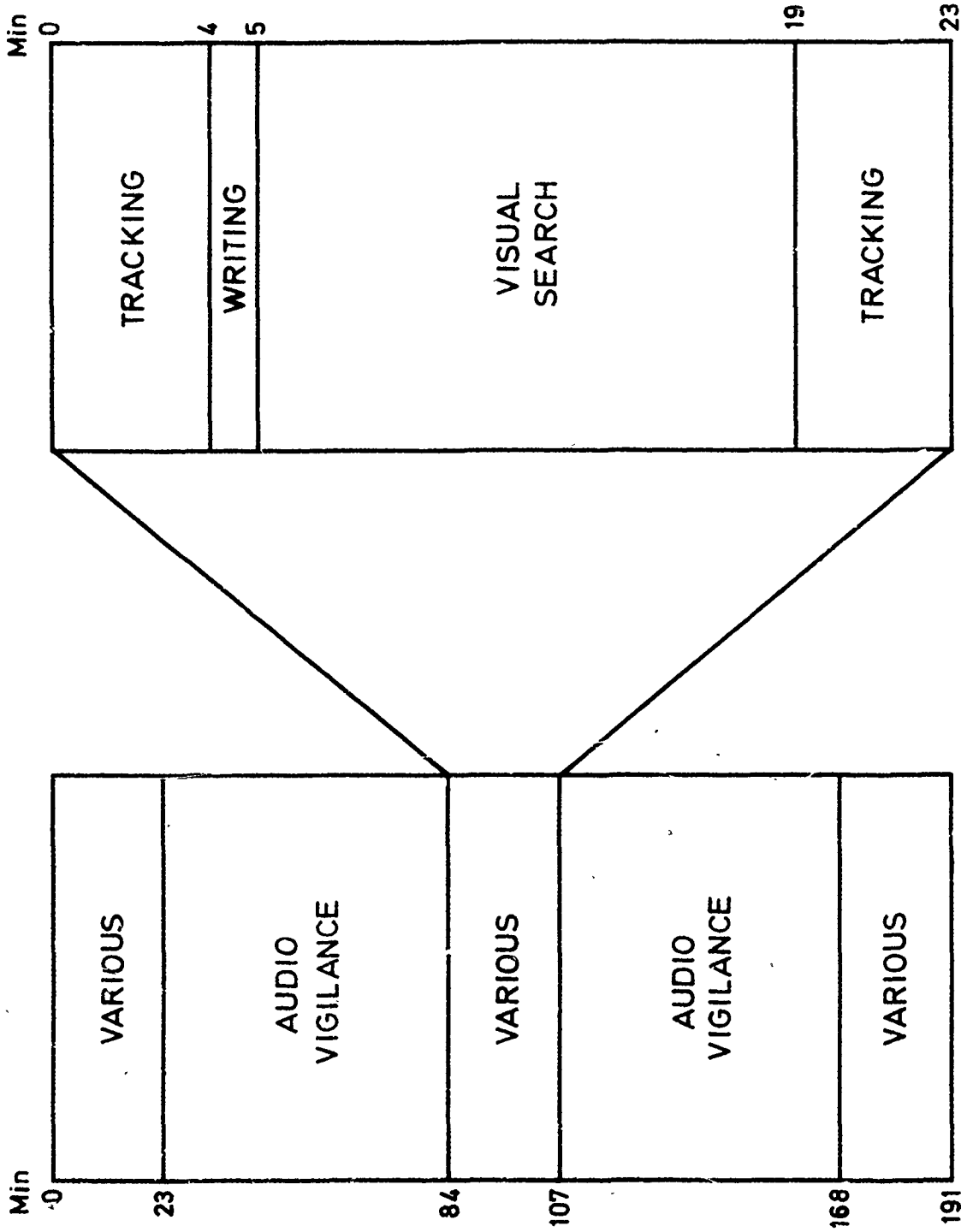

Fig. 8 Timetable of tasks

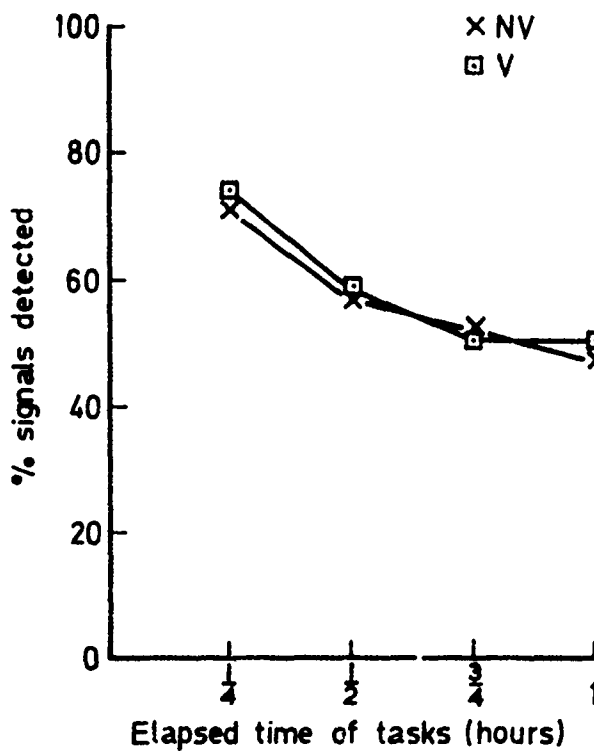

Fig.9 Vigilance task-averaged scores for vibration and no-vibration cases

TR 76011

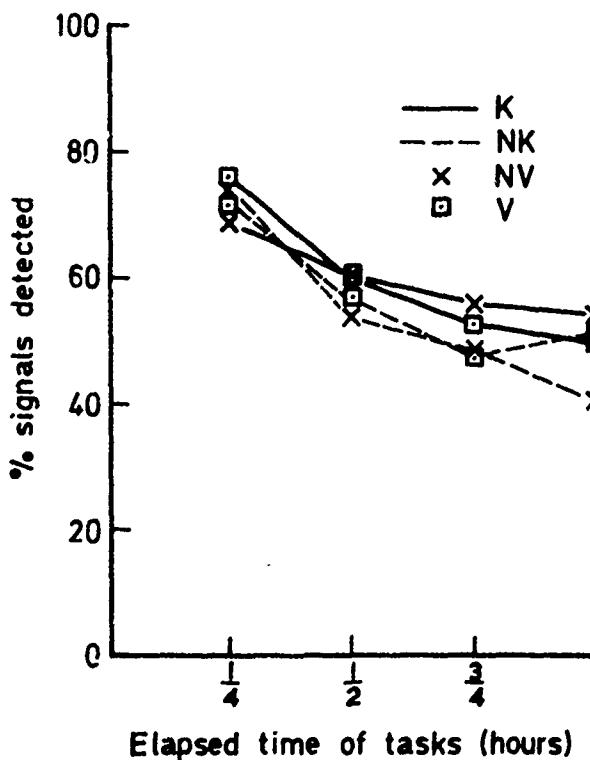

Fig.10 Vigilance task-averaged scores for all four conditions

Figs.11 &12

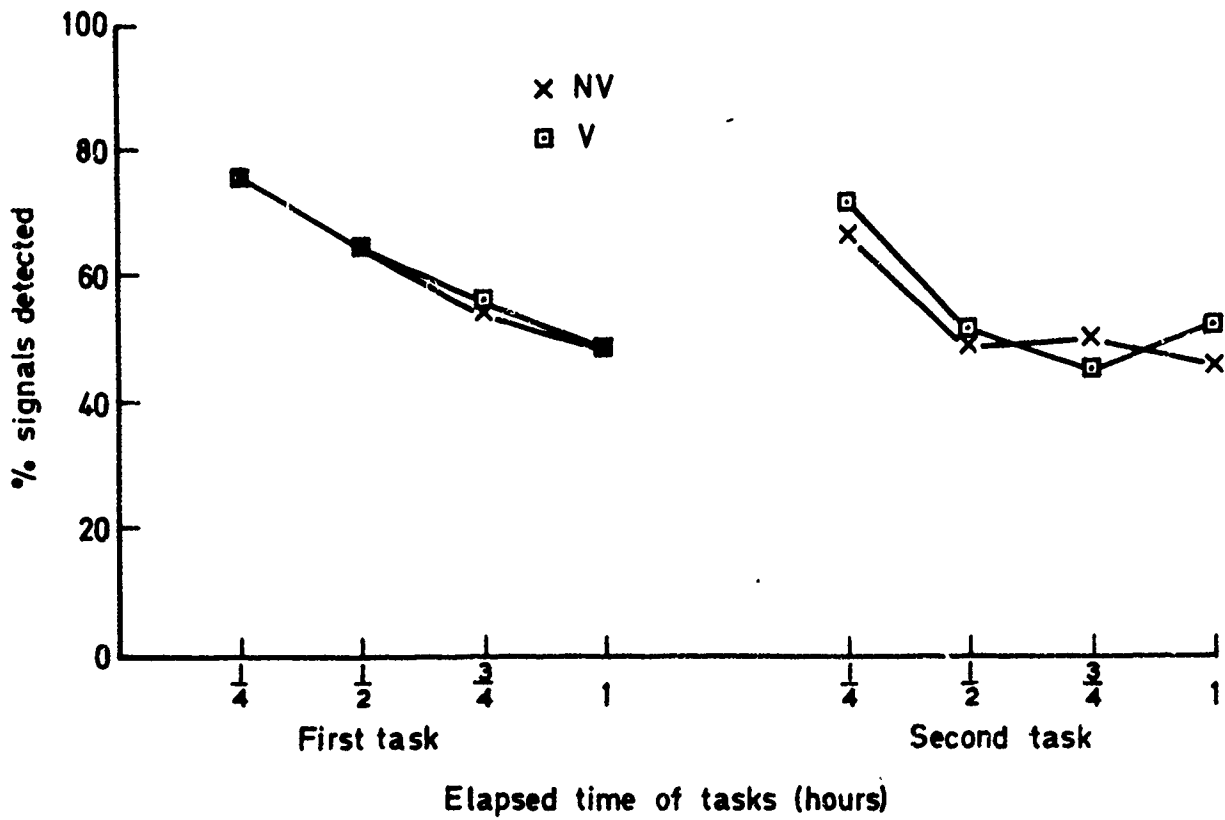

Fig.11 Vigilance task—averaged scores

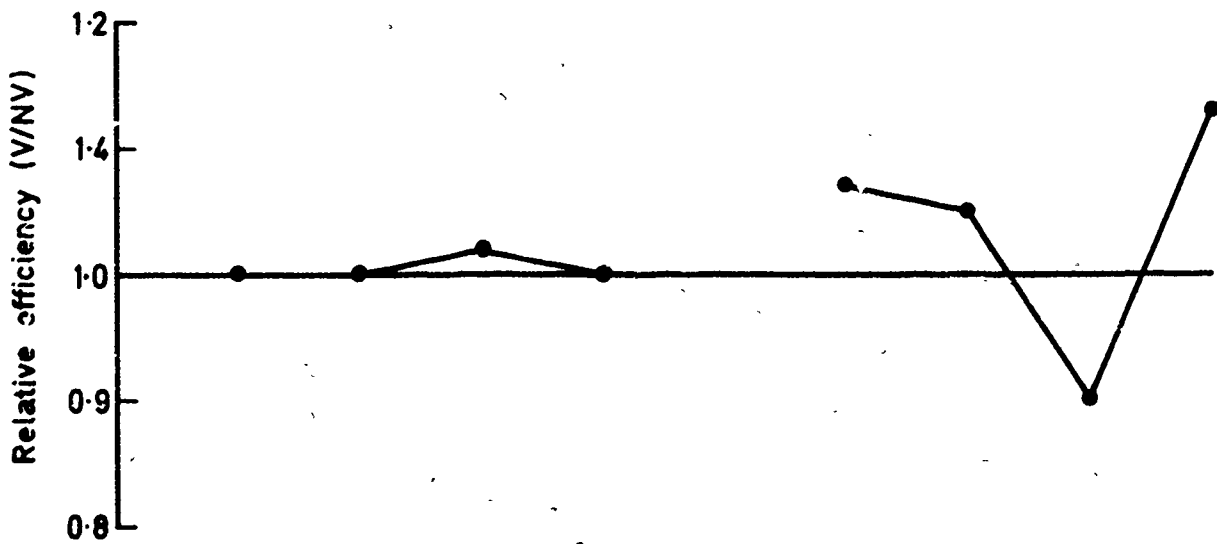

Fig.12 Vigilance task—averaged relative efficiency

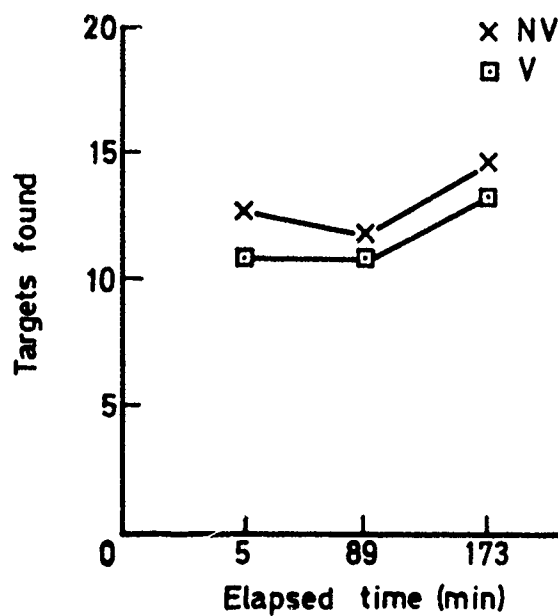

Fig.13 Visual search task - averaged scores for vibration and no-vibration cases

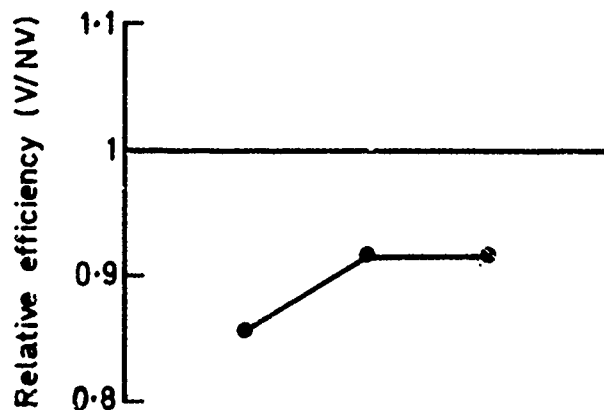
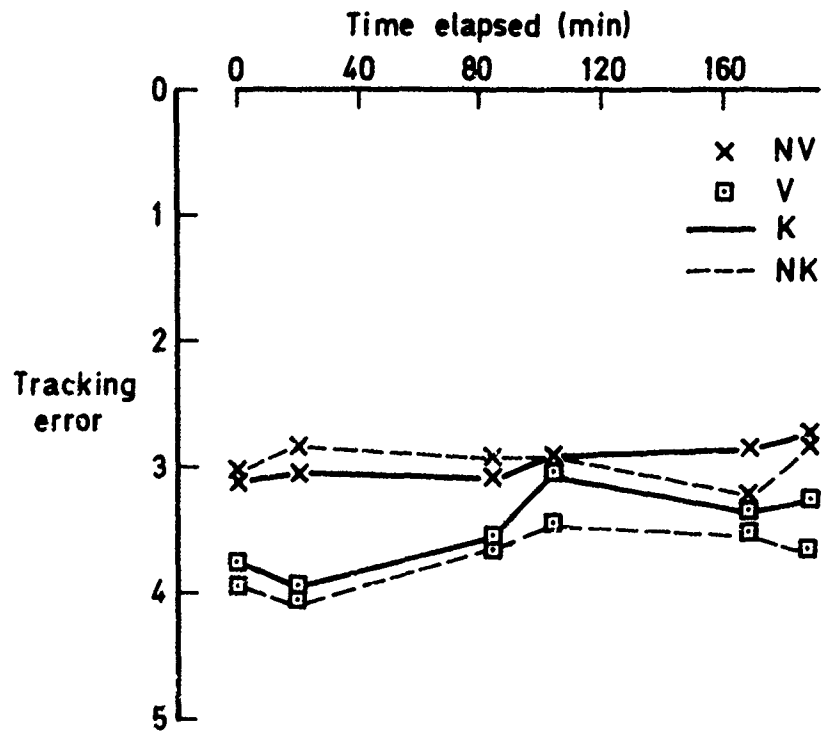

Fig.14 Visual search task - average relative efficiency

TR 76Q11

Fig. 15



TR 76011

Fig.15 Tracking task-averaged scores for all four conditions

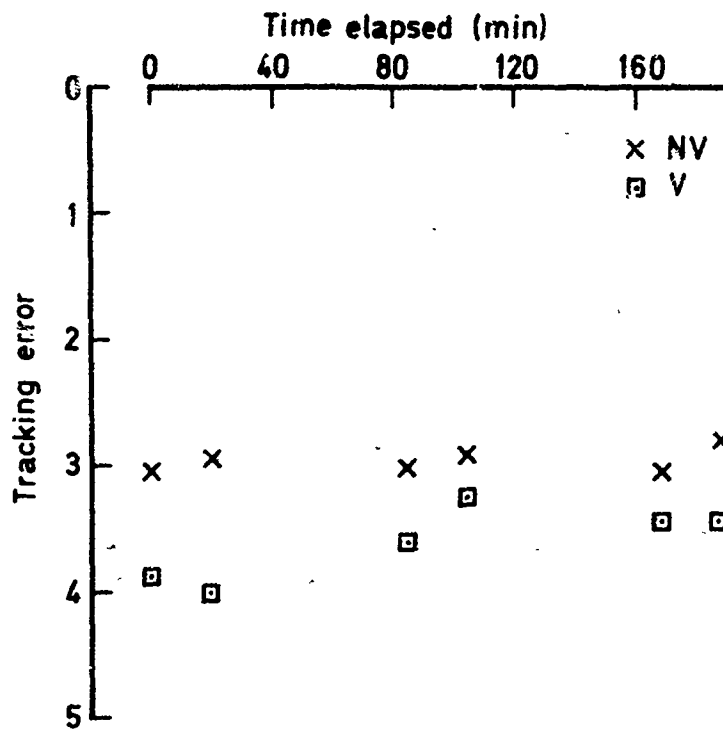

Fig.16 Tracking task-averaged scores for vibration and no-vibration cases

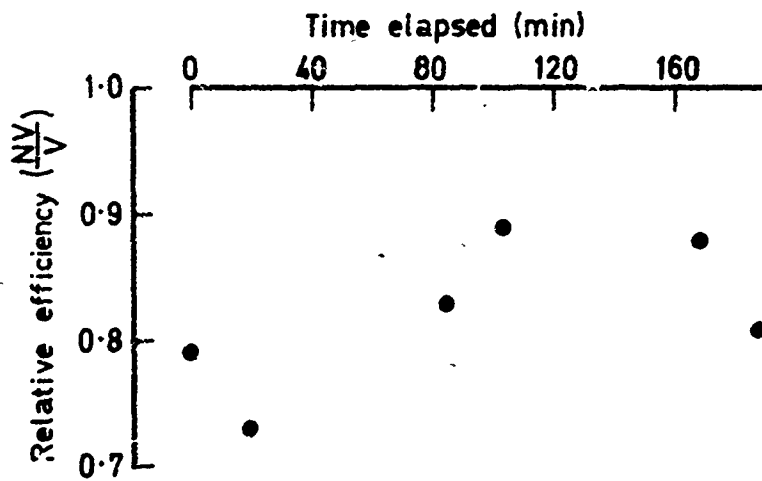

Fig.17 Tracking task-average relative efficiency

TR 76011

Figs.18&19

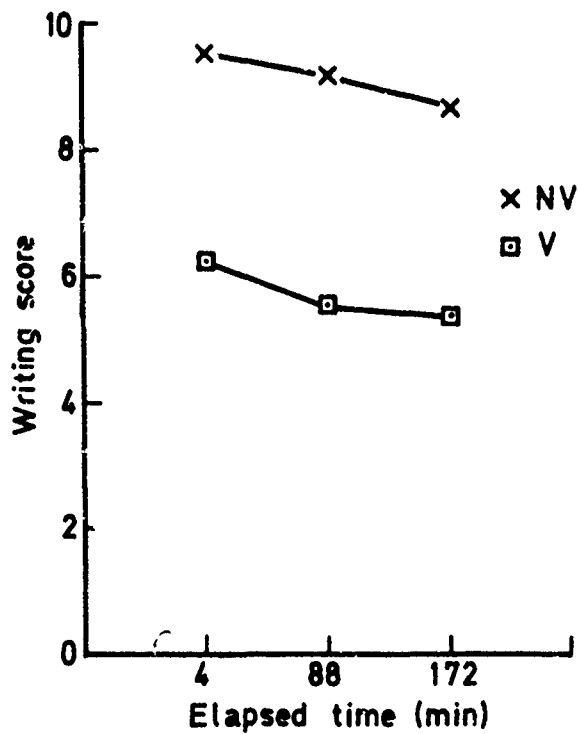

Fig.18 Writing task-averaged marks for vibration and no-vibration cases

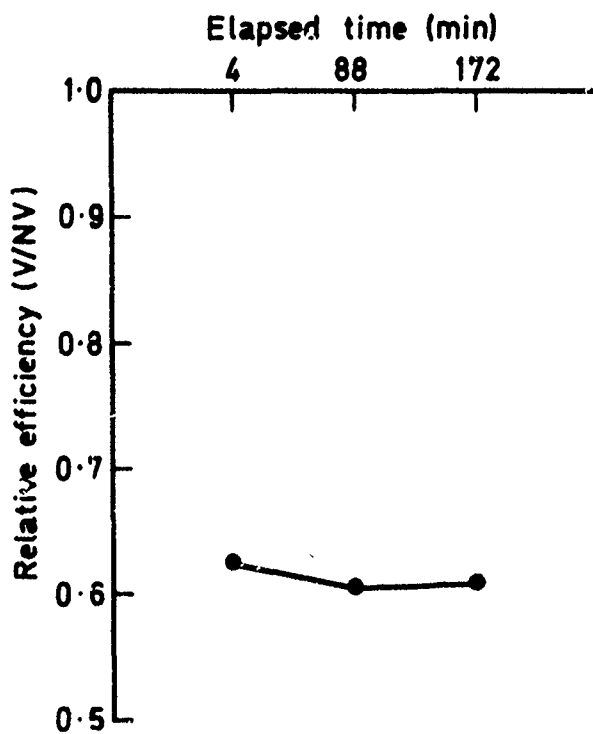

Fig.19 Writing task-average relative efficiency

Fig. 20a

TR 76011

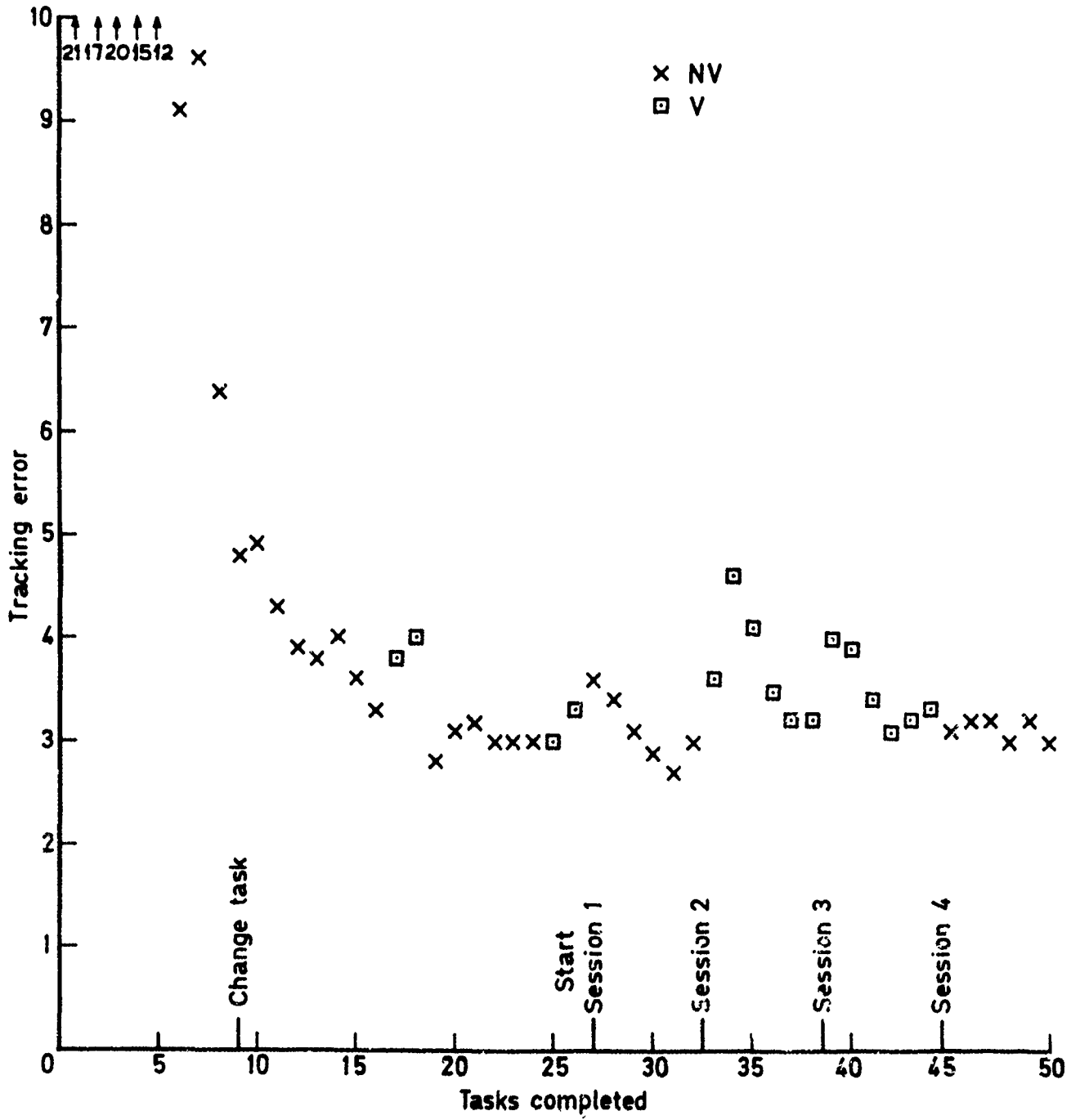

Fig.20a Tracking task performance - Subject a

Fig. 20b

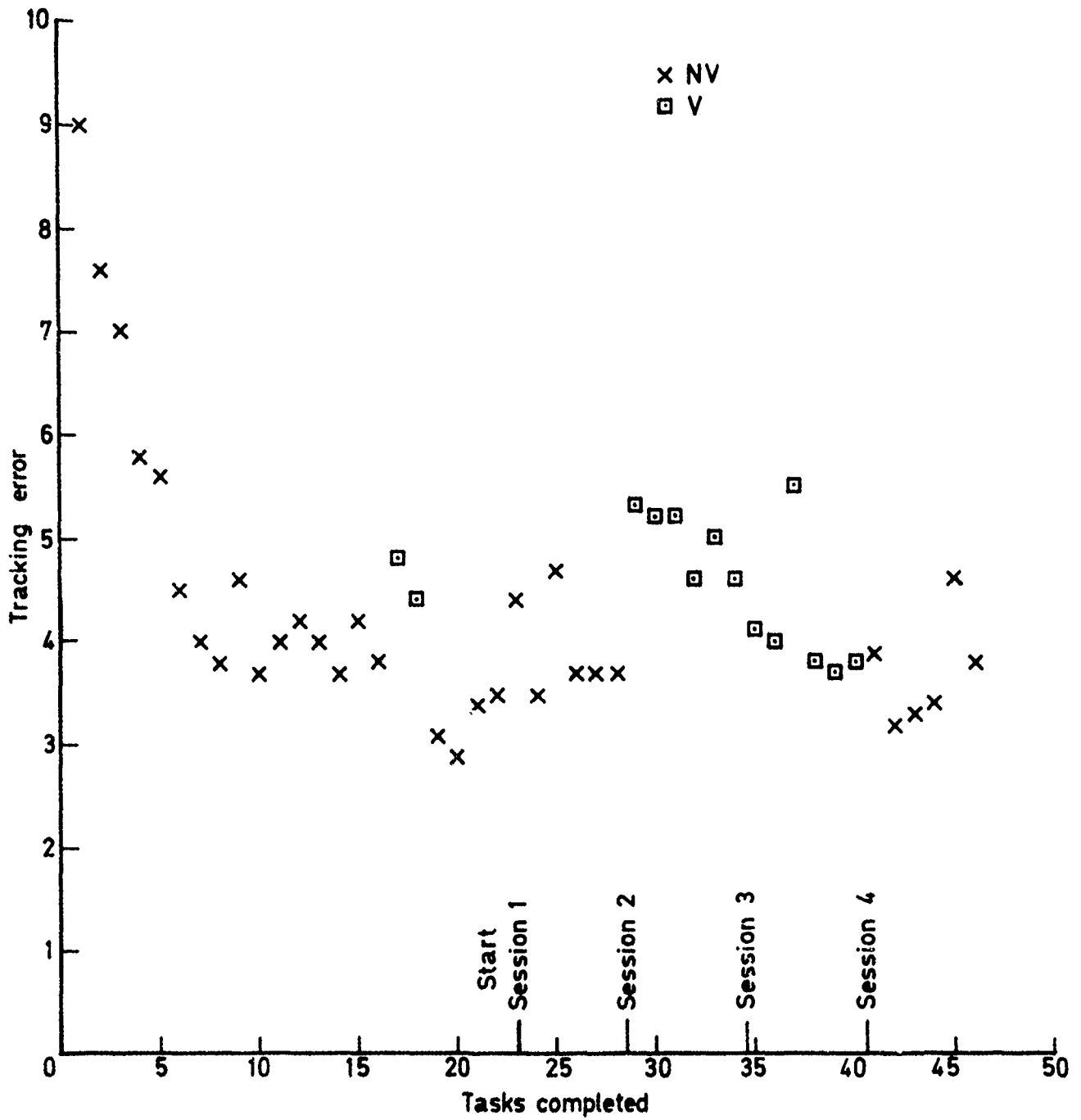

Fig. 20b Tracking task performance - Subject b

Fig. 20c

TR 76011

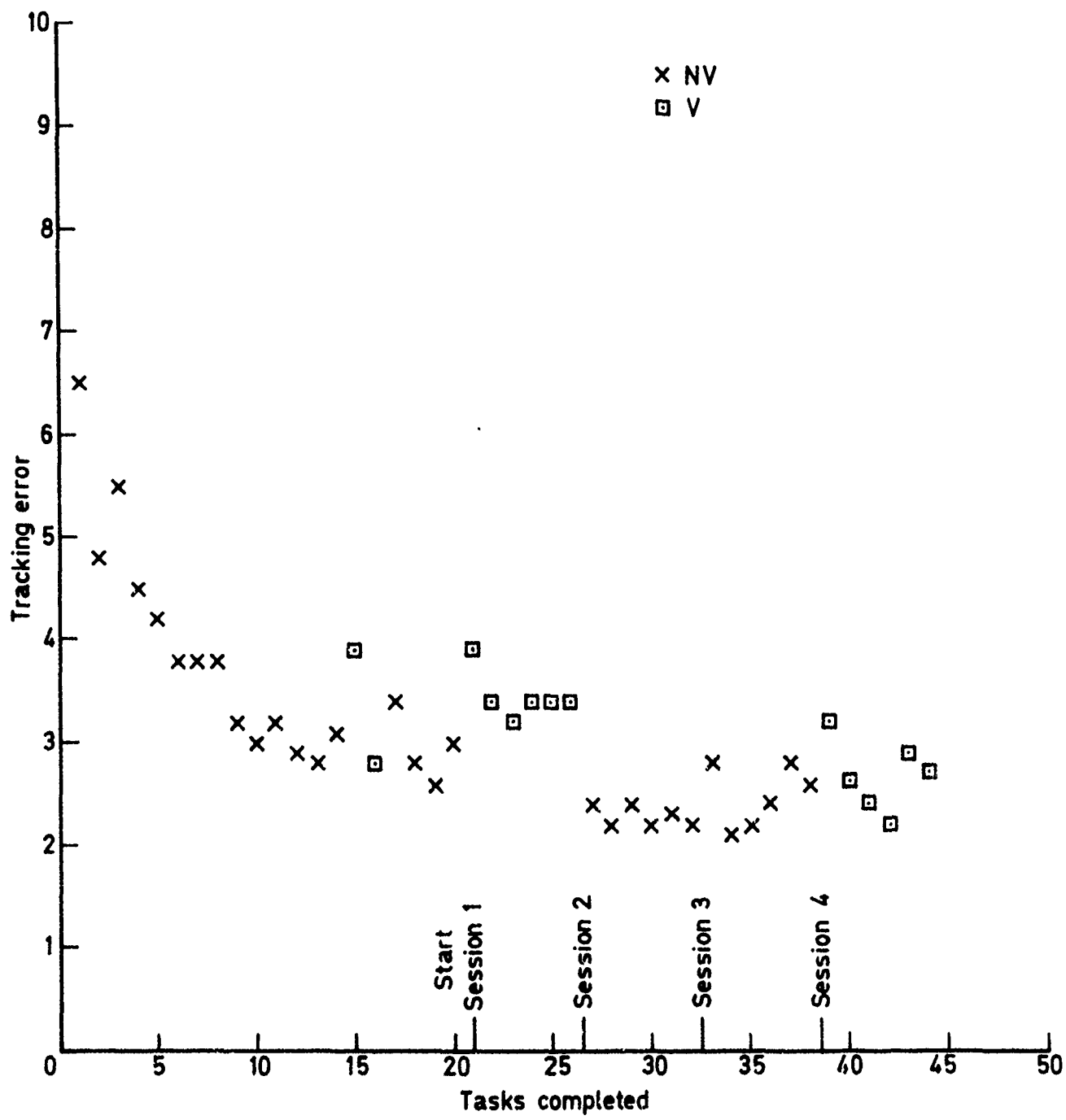
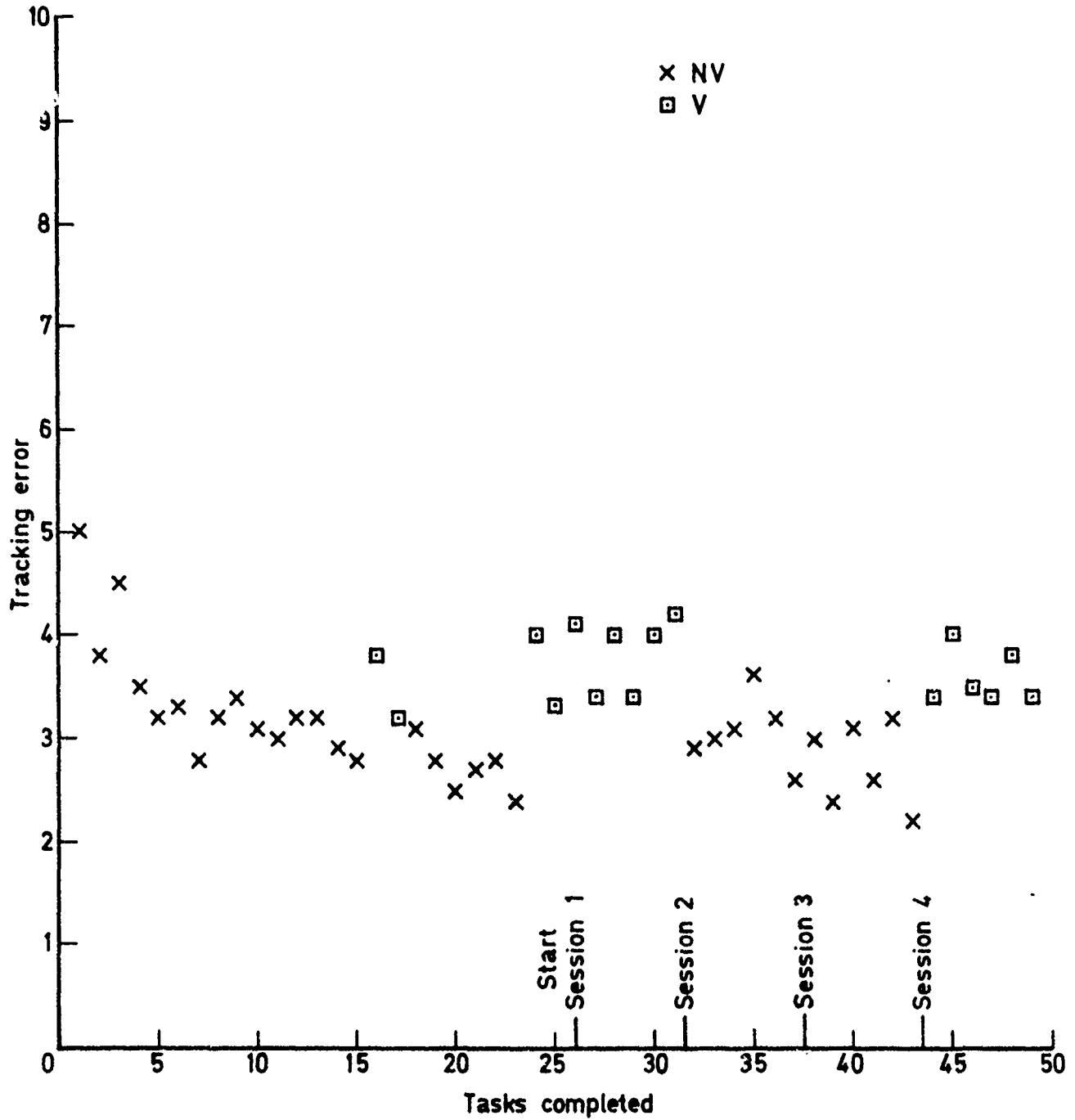

Fig.20c Tracking task performance - Subject c

Fig. 20d



TR 76011

Fig 20d Tracking task performance - Subject d

Fig. 20e

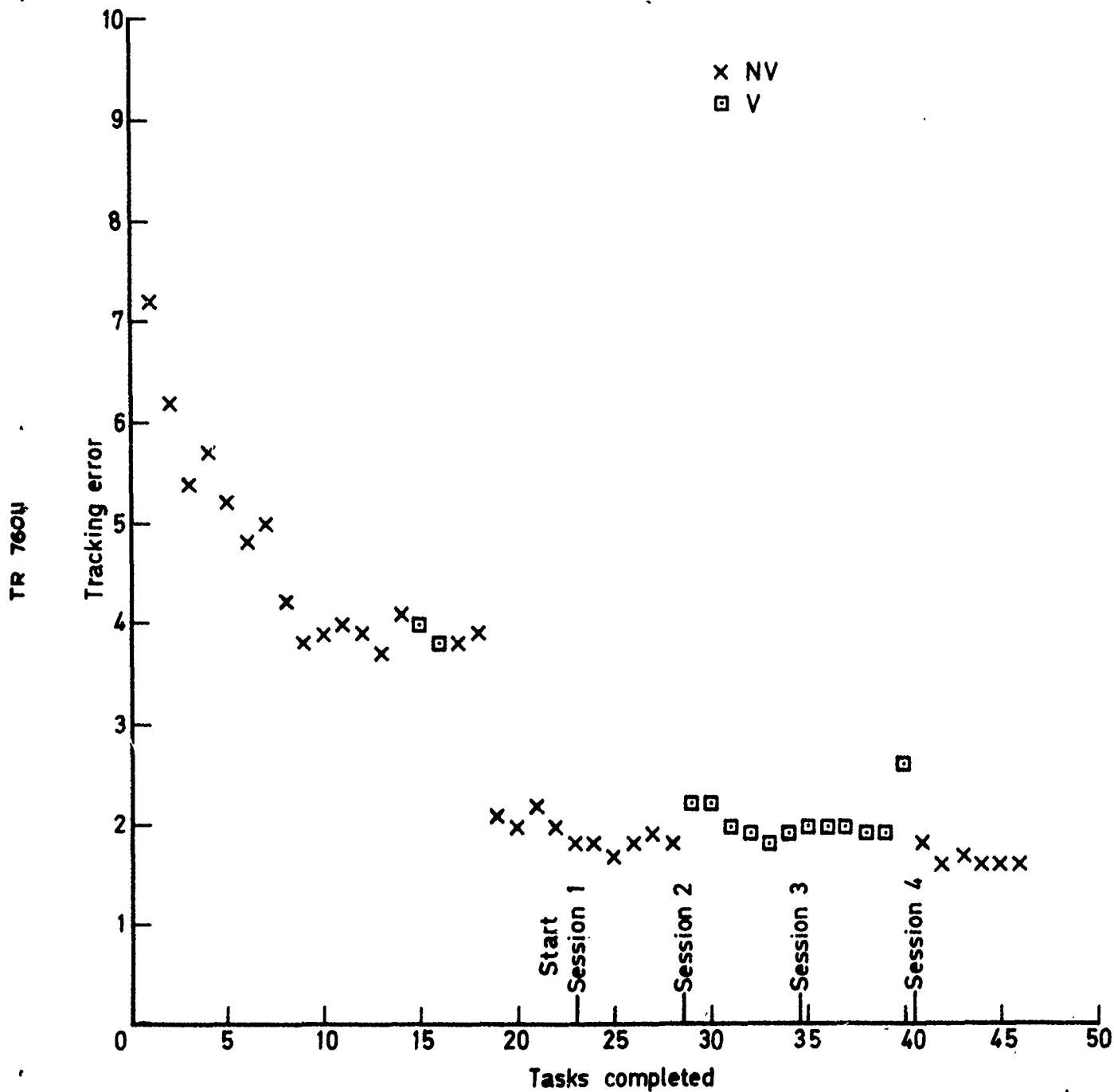
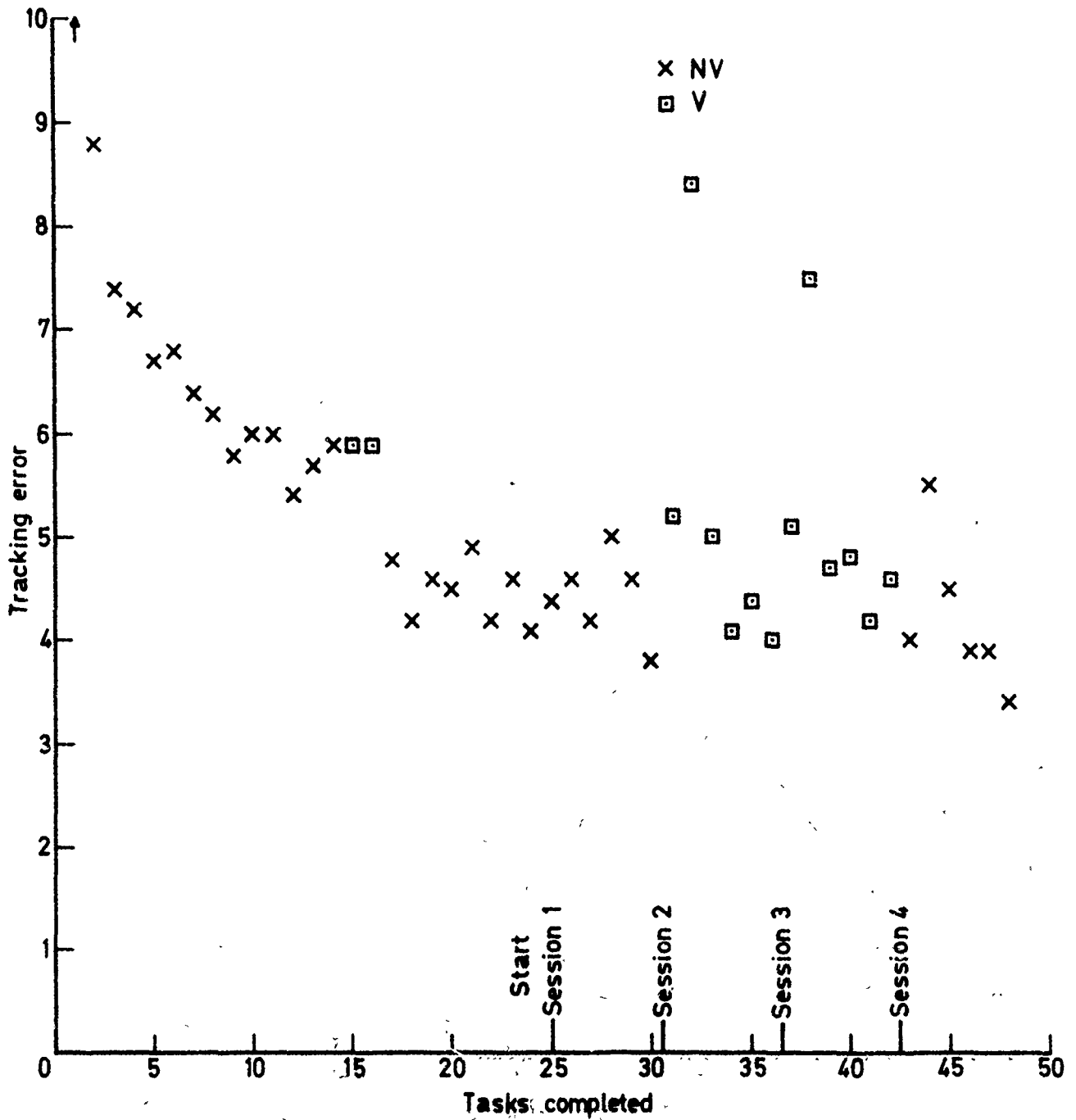

Fig. 20e Tracking task performance - Subject e

Fig. 20f



TR 76011

Fig. 20f Tracking task performance - Subject f.

Fig 20g

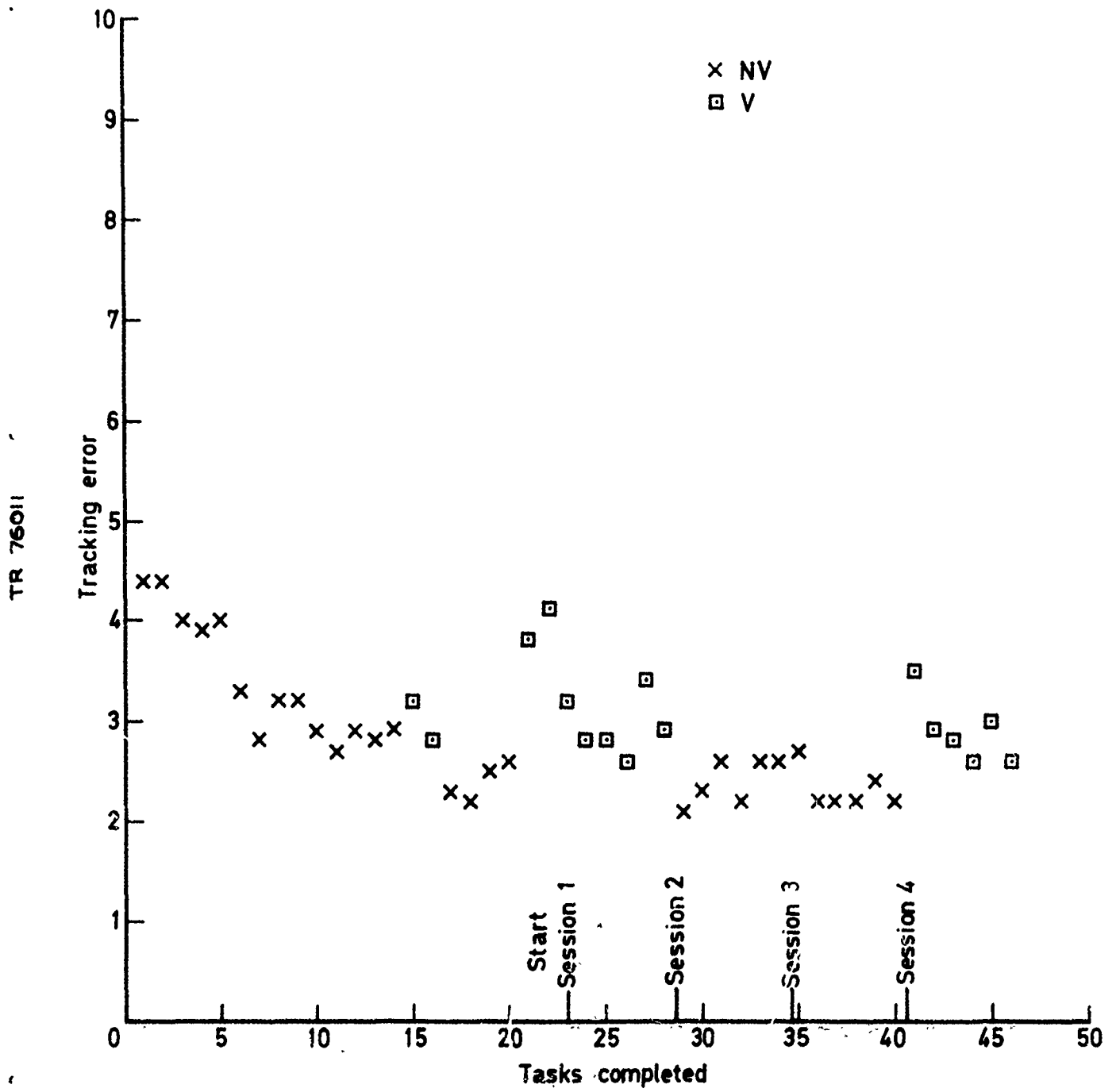
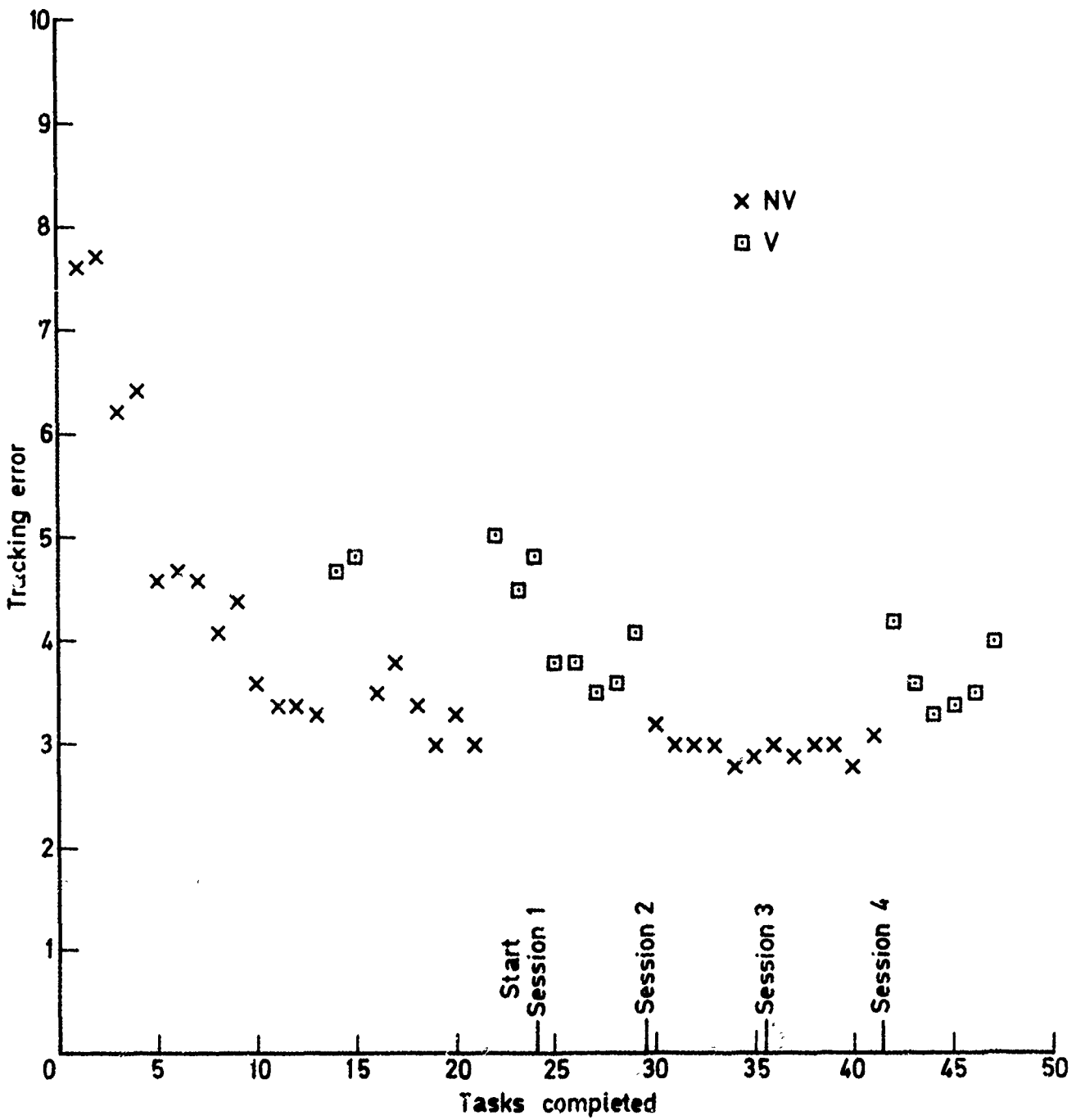

Fig.20g Tracking task performance - Subject g

Fig. 20h



TR 76Q11

Fig. 20h Tracking task performance—Subject h

TR 76Q11

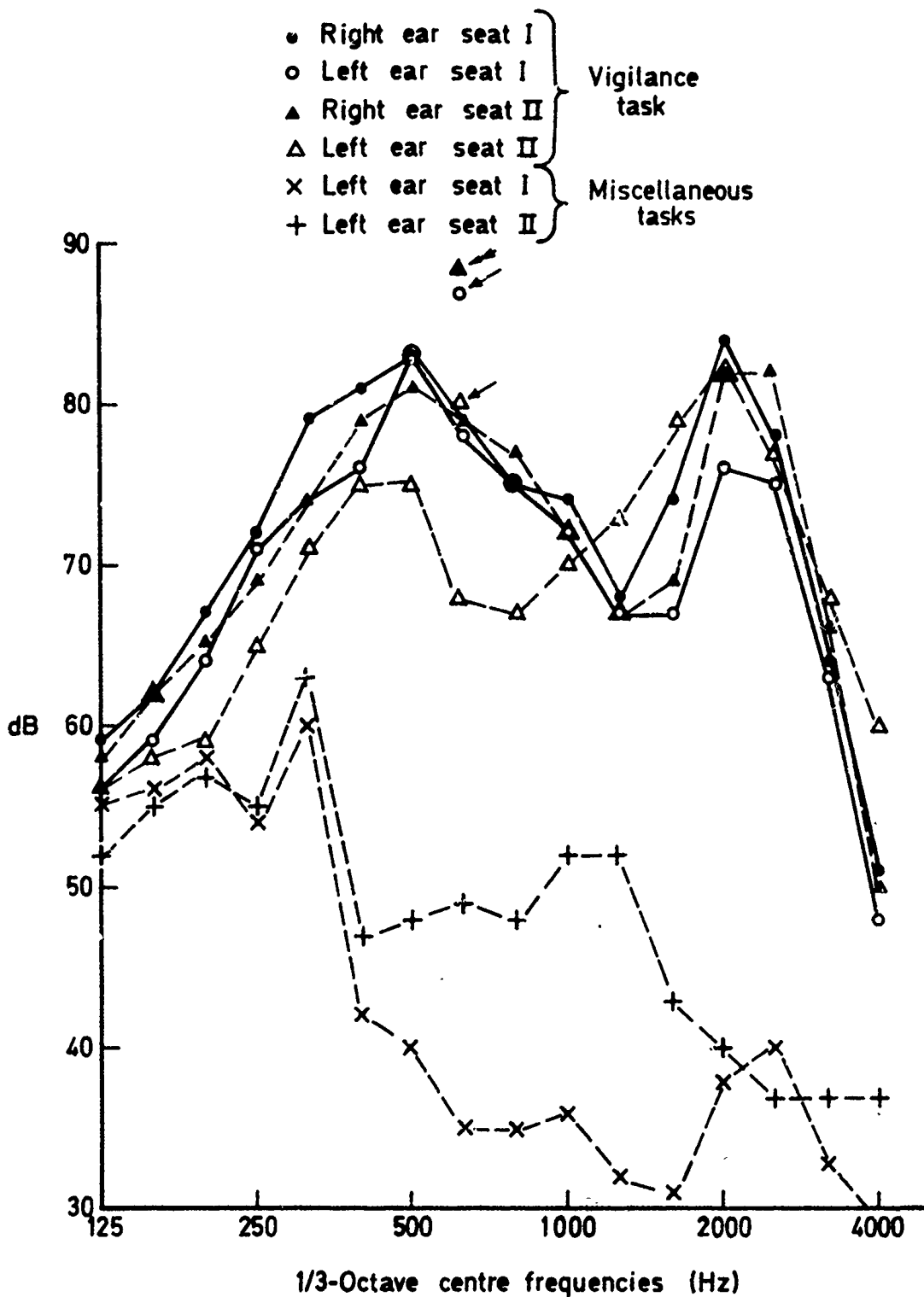

Fig. 21 Noise level inside headphones during vigilance and miscellaneous tasks