

AD-A032 313

NORTHEASTERN UNIV BOSTON MASS
INSTRUMENTATION SYSTEMS FOR MASS SPECTROMETERS. (U)
SEP 76 J S ROCHEFORT, R SUKYS

F/G 14/2

F19628-74-C-0042

UNCLASSIFIED

AFGL-TR-76-0200

NL

1 of 1
ADA032313



END
DATE
FILMED
1 - 77

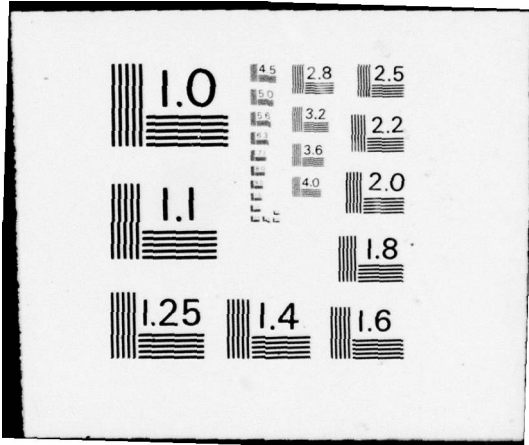

12

[Handwritten signature]

AFGL-TR-76-0200

INSTRUMENTATION SYSTEMS FOR MASS SPECTROMETERS

J. Spencer Rochefort
Raimundas Sukys

Northeastern University
Boston, Massachusetts 02115

Approved for public release; distribution unlimited.

September 1976

Final Report
Period Covered: 1 September 1973 through 31 July 1976

AIR FORCE GEOPHYSICS LABORATORY
AIR FORCE SYSTEMS COMMAND
UNITED STATES AIR FORCE
HANSCOM AFB, MASSACHUSETTS 01731

DDC
RECEIVED
NOV 23 1976
RECEIVED

[Handwritten initials]

B

AD A032313

Qualified requestors may obtain additional copies from the Defense Documentation Center. All others should apply to the National Technical Information Service.

Unclassified

D.D.
MIL-STD-847A
31 January 1973

SECURITY CLASSIFICATION OF THIS PAGE (When Data Entered)

REPORT DOCUMENTATION PAGE		READ INSTRUCTIONS BEFORE COMPLETING FORM	
1. REPORT NUMBER 18 AFGL-TR-76-0200	7. GOVT ACCESSION NO.	3. RECIPIENT'S CATALOG NUMBER 9	
4. TITLE (and Subtitle) INSTRUMENTATION SYSTEMS FOR MASS SPECTROMETERS		5. TYPE OF REPORT, PERIOD COVERED, etc. FINAL REPORT, 1 Sep 1973-31 Jul 76	
6. PERFORMING ORG. REPORT NUMBER		8. CONTRACT OR GRANT NUMBER(s)	
9. AUTHOR 10 J. Spencer/Rochefort Raimundas Sukys	15	F19628-74-C-0042	
13. PERFORMING ORGANIZATION NAME AND ADDRESS Northeastern University 360 Huntington Avenue Boston, Massachusetts 02115		10. PROGRAM ELEMENT, PROJECT, TASK AREA & WORK UNIT NUMBERS 61102F 16 86051101 17 11	
11. CONTROLLING OFFICE NAME AND ADDRESS Air Force Geophysics Laboratory Hanscom AFB, Massachusetts 01731 Monitor: Alan D. Bailey/LKD		12. REPORT DATE 11 1 Sep 1976	
14. MONITORING AGENCY NAME & ADDRESS (if different from Controlling Office)		13. NUMBER OF PAGES 12 44 P-1	
		15. SECURITY CLASS. (of this report) Unclassified	
		15a. DECLASSIFICATION/DOWNGRADING SCHEDULE	
16. DISTRIBUTION STATEMENT (of this Report) Approved for public release; distribution unlimited.			
17. DISTRIBUTION STATEMENT (of the abstract entered in Block 20, if different from Report)			
18. SUPPLEMENTARY NOTES			
19. KEY WORDS (Continue on reverse side if necessary and identify by block number) Mass Spectrometer Quadrupole Exciter Rectangular Waveform Circuits			
20. ABSTRACT (Continue on reverse side if necessary and identify by block number) Two rectangular waveform generators to excite the rods of a quadrupole mass spectrometers are described. One of the units may be operated between one and two MHz with an output voltage ranging from 4 to 80 volts. The rise and fall times are less than 50 ns. The other unit operates at one MHz over a 4 to 200 volt range with the rise and the fall times of 30 ns			

next page

DD FORM 1, JAN 73 1473 EDITION OF 1 NOV 55 IS OBSOLETE

Unclassified

SECURITY CLASSIFICATION OF THIS PAGE (When Data Entered)

260 100
copy

Unclassified

cont.

SECURITY CLASSIFICATION OF THIS PAGE (When Data Entered)

while driving a 30 pF load. Also included in the report are summaries of previously reported work: circuits to control a thermal emission unit used in an experiment to control vehicle potential; bias circuits for a mass spectrometer in the project EXCEDEX (SWIR experiment); and modifications performed on existing mass spectrometers intended for the studies of the upper atmosphere.

PROCESSED for	
WTS	White Section <input checked="" type="checkbox"/>
BTC	Blue Section <input type="checkbox"/>
FINANCIALS	<input type="checkbox"/>
JUSTIFICATION	
BY	
DISTRIBUTION AVAILABILITY STATEMENTS	
Dist.	AVAIL. STATEMENTS
A	

Unclassified

SECURITY CLASSIFICATION OF THIS PAGE (When Data Entered)

PREFACE

Research referred to in Chapter IVB was sponsored by the Defense Nuclear Agency under subtask LIICAXHX504 entitled "Rocketborne Chemical Specie Measurements".

This research is reported in AFGL-TR-76-0060 "Bias and Signal Processing Circuits for a Mass Spectrometer in the Project EXCEDE: SWIR Experiment", R. Sukys et al, Oct. 1975, Scientific Report No. 2.

TABLE OF CONTENTS

	<u>Page No.</u>
I. INTRODUCTION - - - - -	1
II. THE EIGHTY VOLT EXCITER FOR A QUADRUPOLE - - - - -	3
A. The Output Switch - - - - -	3
B. Frequency and Duty Cycle Control - - - - -	7
C. Supply Voltage Sweep Amplifiers - - - - -	10
III. THE TWO HUNDRED VOLT EXCITER - - - - -	12
A. The Switch - - - - -	12
B. Switch Control - - - - -	17
C. Sweep Voltage Circuits - - - - -	19
IV. SUMMARY OF OTHER WORK - - - - -	20
A. Circuits for an Experiment to Control Vehicle Potential -	20
B. Bias Circuits for a Mass Spectrometer in SWIR Experiment	22
C. Modifications in Mass Spectrometer Electronics - - - - -	25
V. PERSONNEL - - - - -	27
VI. RELATED CONTRACTS AND PUBLICATIONS - - - - -	27
VII. REFERENCES - - - - -	28

PRECEDING PAGE BLANK-NOT FILMED

TABLE OF ILLUSTRATIONS

<u>Figure No.</u>	<u>Page No.</u>
1. Block Diagram of Quadrupole Exciter	29
2. The 80 Volt Switch	30
3. Frequency and Duty Cycle Control Circuits	31
4. Supply Voltage Sweep Amplifiers	32
5. The 200 Volt Switch	33
6. Output Waveform at Four Volts	34
7. Output Waveform at Hundred Volts	34
8. Output Waveform at Two Hundred Volts	34
9. Rise and Fall Times at Two Hundred Volts	35
10. Switch Control Circuit	35
11. Sweep Amplifiers	36
12. Vehicle Potential Control Experiment Diagram	37

I. INTRODUCTION

The first two chapters of this report are devoted to the description of rectangular waveform generators developed to excite the rods of a quadrupole mass filter. In the last chapter a summary of other work performed under this contract is presented. The major portion of the work was concerned with modifications of electronic assemblies to control the operation of rocket-borne mass spectrometers. In addition, circuits to control the thermal emission of electrons for a vehicle potential control experiment were developed.

Since its development the quadrupole mass filter has been driven by an excitation signal consisting of a dc and a sinusoidal radio frequency components. Conventionally the quadrupole spectrometers are mass scanned by varying, in unison, the two components of the excitation signal. To preserve the performance of the filter, the ratio of the dc and the RF components must remain nearly constant over the scan range. This may lead to some difficulties in instruments exposed to hostile environment.

It has been shown that the combined dc and the sinusoidal signals may be replaced by a single rectangular excitation signal.¹ A highly selective mass filtering may be achieved by controlling the duty cycle of the waveform. Thus the need to generate two signals and to maintain a constant relation between the two voltages may be replaced by a single rectangular signal and a controlled timing operation.

Two units which generate rectangular waveforms suitable to drive the mass filters have been constructed. One of the units generates a 4 to 80 V peak-to-peak waveforms whose period may be manually varied from 500 to 1000

ns in 50 ns steps. The pulse width may be incrementally selected within 5 ns of the desired value and then continuously varied over a 10 ns range. The transition times between the two extreme voltage levels are less than 50 ns. The other oscillator operates at a fixed frequency of one MHz over a 4V to 200V range with transition times of 30 ns. Each exciter consists of three major circuit components: the voltage switch and associated driver circuits including opto-isolators, the frequency and duty cycle controller and the sweep amplifiers. A general block diagram applicable to both exciters is shown in Figure 1. The details of the circuits represented by the blocks together with some design considerations are described in the first two parts of the report.

The last chapter contains descriptions of two previously reported electronic systems^{2, 3} and a summary of other work performed on mass spectrometers. A brief description is presented of circuits designed to control a thermal emission system. This system was used to demonstrate the feasibility of vehicle potential control through the emission of low energy electrons during a flight.⁴

Also described in that section are the bias and signal processing circuits for a mass spectrometer flown as a part of project EXCEDE: SWIR experiment.⁵ During this experiment large negative bias voltages were applied to the front plate and the grid structure of the mass spectrometer to overcome the repelling effect of a positively charged vehicle on the positive ions. The positive charge build-up was the result of a periodic injection of electrons into the atmosphere by an electron accelerator.

II. THE EIGHTY VOLT EXCITER FOR A QUADRUPOLE

A. The Output Switch

The switching circuit of the 80 volt square wave oscillator is shown in Figure 2. The complementary pair of transistors D40D11 and D41D11 switch the voltages and drive the rods of the quadrupole mass spectrometer. Optically coupled isolators HP4360 are used to couple the control signals from the logic circuits and to provide the drive for the switching transistors.

Selection of the switching transistors was based on a number of considerations and compromises between the parameters of the available units. The parameters considered included breakdown voltages, switching speed, capacitances, device power dissipation and drive requirements. The capacitances are of great importance, since they not only exert a considerable influence on the overall power consumption, device drive and power dissipation requirements, but, also, allow the switching transients to interfere with the control circuit operation. The parameters of the selected transistors seemed to represent the best compromise in all respects. Their collector to base capacitance (C_{ob}) of approximately 10 pF combined with 1.2A peak collector current and a relatively high current gain ($h_{FE} = 100$ at $I_C = 200$ mA) were the deciding factors in the selection. It was assumed, as a design goal, that a total of 100 pF will have to be driven in 40 nanoseconds through a transition of 80 volts. Therefore, assuming a constant current drive, 200 mA had to be supplied to the capacitors according to:

$$I = \frac{\Delta V}{\Delta T} C$$

where ΔV is the change in the capacitor voltage and ΔT represents the

time during which the current I was flowing into the capacitor C . Making a further assumption, that the circuit operates at a maximum voltage (V) of 80 volts and a frequency (f) of two MHz, a power dissipation (P) of 0.64 watts could be anticipated:

$$P = 1/2 V^2 C f,$$

where $1/2 V^2 C$ is the well known expression for the energy stored in a capacitor and f is the frequency at which the device provides the energy to be stored.

The maximum expected power dissipation of less than 0.7 watts is indeed very fortunate, since the transistors are capable of one watt dissipation without heat sinks. If heat sinking were required, it would involve the collectors of the devices and could add more capacitance to the output circuit. This in turn would further increase power dissipation along with some other transient coupling problems.

Separate drive circuits and two 5 volt supplies were provided for each of the two switching transistors. The two supplies were referenced to the slowly varying high voltage supply, (designated as $\pm V_H$ on figure 1), to provide +5 and -5 volts to the driver circuits which, also, were referenced to the same variable supply. The sole purpose of the +5 volt supply in the positive voltage switch circuit was to hasten the removal of the excess minority carrier charge from the base region, thereby speeding up the shutdown process of the transistor. The same statement may be made about the -5 volt supply in the negative voltage switch circuit. The diodes in the base and the collector circuits prevent the transistors from entering saturation and, thus eliminate the unpredictable and difficult to handle time delays between

the two, positive and negative, voltage switching circuits. A considerable amount of the large drive currents supplied by the control circuits to the switching transistors is needed to absorb the switching transients coupled from the output circuit through the capacitances associated with the transistors and the diodes. The additional transistor in the positive voltage control circuit is required to protect the optically coupled driver output stage from an overvoltage. Without the transistor the output stage of the HP4360 unit would be subjected to +10 volts when the positive voltage switch is off. Since the unit is rated at seven volts a damage could result.

The output waveform of the switching circuit exhibits an undershoot just before the signal starts rising and an overshoot just before the waveform starts moving toward the negative supply voltage. The peaks, approximately two volts in amplitude, occur 30 to 40 nanoseconds after the optics receive a simultaneous commands to switch. This is caused by the inherent property of these switches to turn off faster than to turn on. When the output is at the negative voltage level and the transistors receive at their bases a command to switch, that command is a negatively going voltage. The negative switch turns off but a part of that command signal is coupled to the output through the base to collector circuit capacitance. The output reverses its direction when the positive switch starts conducting. Similar explanation could be given for the overshoot occurring just before the output waveform starts decreasing towards the negative supply voltage. The two transients may be decreased by delaying the turn off command with respect to the turn on signal. But an overlap of even a few nanoseconds

must be avoided. Large currents during the overlap period would increase the demand on the power supply and could cause switching transistor failure due to excessive power dissipation.

In this system large currents and voltages are switched in nanoseconds. Voltage changes in the order of 10^9 volts per second are comparable with the changes in the fastest logic families, where transitions between levels are typically ten times faster but the level separation is sixteen to twenty times smaller. Therefore, circuit layout is quite important. Current paths, their physical placement, as well as, introduction of stray capacitance due to proximity of devices should be carefully considered. An improved performance, for example, was observed when the components were welded into a compact cordwood module over the performance when the circuits were constructed in a flat layout. Transient coupling into the control circuits also should be avoided.

B. Frequency and Duty Cycle Control

Signals to control the optically isolated switches are generated by the circuits shown in Figure 3. The period of the control signal may be manually varied from 500 ns to 1000 ns in 50 ns steps. The pulse width may also be manually controlled between 200 and 500 ns. Two sets of incremental controls allow a pulse width selection within 5 ns of a desired value while an additional continuous vernier control has a 10 ns range.

A shift register consisting of five 74S194 circuits and driven by a 20 MHz oscillator (K1091A) form the base of the control circuit. The shift register is connected to operate in a serial data input mode and, once it has been fully loaded, to accept data in the parallel mode during a single positive clock transition. The serial loading is accomplished by the +5 volt signal at the D_{SR} terminal of the first shift register unit and a ZERO at the S_1 terminals. The S_1 signal is supplied by the 20th position of the shift register. As long as that position remains low the shift register is serially loaded through the D_{SR} terminal. Once the 20th position is loaded with a ONE, the shift register is ready to accept on the next clock pulse parallel data presented at the input terminals.

The parallel data to the shift register is presented by selecting one of the ten switches connected to the OR gates (SN7432). If none of the switches is closed, only the first position of the shift register is loaded during the parallel loading event. In that case, it takes 20 clock periods to fully load the register through the D_{SR} terminal and then to repeat the parallel load command. Thus a period equal to one microsecond is obtained. Closing the switch at the eleventh input position forces a

logical ONE to be present at all input terminals to the left of that position. All eleven register locations are now loaded in parallel. Therefore, it takes only ten clock periods to recycle to the starting status. Thus 500 ns period is obtained. Periods between the two extreme values, in increments of 50 ns, may be obtained by closing other switches.

Output pulses and pulse width control are obtained from the shift register output positions eleven through sixteen. With all switches to the AND gates open, a ONE at the output position sixteen will propagate through the open collector AND-OR-INVERT gates (SN74S65) and will appear as an input to the delay line. The duration of that pulse will be 250 ns. It requires four clock periods of 50 ns each for the leading ONE in the register to be shifted from the 16th into the 20th position. An additional clock period is required to reload the shift register with the input data, thus ending the output pulse.

Closure of a switch at any output terminal (11 through 15) adds 50 ns to the pulse duration for each position that the switch is removed from terminal sixteen. Therefore, closing the switch at output terminal eleven would produce a 500 ns pulse at the delay line. Once a switch is closed, other switches to the right of it have no effect on the pulse duration.

Lockout circuits have been introduced to insure that the output waveform will dwell at the ZERO level for at least 200 ns during each period. This is accomplished through the inverters SN7404. Every time a ONE is present at an input (A through D) of the shift register, which could produce an output pulse with less than 200 ns at the ZERO level, appropriate AND gates at the output are disabled. Thus, a ONE at C disables gates A

through C, since the inputs B and C also reside at the upper logic level.

Further control over the pulse duration may be exercised through the circuits associated with the 50 ns delay line. By closing an appropriate switch the output pulse may be stretched an additional 50 ns in 5 ns steps beyond the pulse duration obtained from the shift register circuits.

A continuously variable vernier control of the pulse duration also has been added. The -741 operational amplifier through the 750 ohm resistor provides the collector voltage for the output transistors of the SN74S65 units. By controlling the output voltage of the operational amplifier, the elapsed time between the shut-off of the transistor and the turn-on of the SN54S04 inverter can be varied. A vernier voltage of 2.5 to 5 volts varies the lagging edge of the output pulse by approximately 10 ns.

Timing between the turn-on and the turn-off of the transistors driving the rods of the mass spectrometer may be adjusted by making appropriate connections to the delay line in the output circuit. This output circuit is mainly used to reduce the overshoot and the undershoot in the output waveform. The delay line connections to the NAND gates may vary with the individual characteristics of the oscillator output switches. The NAND gate circuits provide control signals, coupled through the optical isolators, to drive the two sets of transistor switches which supply the quadrupole rods with the two out of phase square wave signals. Therefore, each gate drives the two LED's which turn the positive switch of one output circuit and the negative switch of the other circuit ON at the same time. Small time delays may be equalized by bypassing the 1N4148 diodes with capacitors.

C. Supply Voltage Sweep Amplifiers

The slowly variable positive and the negative voltages are supplied to the switches by the circuit shown in Figure 4. The circuit requires two sources of +50 and -50 volts each capable to supply 50 mA of current and one well regulated supply of +15 volts at 10 mA. Relatively poor voltage regulation is acceptable from the high voltage supplies, provided the voltages remain above 50 volts under all operating conditions. The necessary regulation of the positive and the negative voltages is provided by the circuits containing the T1P142 and T1P147 transistors respectively. Voltage reference is supplied by the zener diodes (1N976B) driven by 3.3 mA current sources (CL3320). Approximately 43 volts are available at the emitters of the regulator transistors to drive the sweep circuits.

The negative zero to minus five volt sweep control signal is isolated from the output amplifiers by the CA3130 circuit. An operational amplifier 741DM and the 2N2243 transistor amplify that signal and provide the necessary current drive capability. A current source (CL1520) in the emitter circuit is used to provide a current path for the emitter follower during the periods when the switches do not draw any current. This arrangement provides for a constant current drain of 1.5 mA regardless of the output voltage amplitude. The current source and the 1N5711 diode stabilize the circuit.

A similar circuit arrangement supplies the negative sweep voltage to the output switches. This circuit is driven by the positive sweep signal. Unity gain configuration insures that the positive and the negative signals track each other.

Components at the non-inverting terminals of the two sweep voltage amplifiers provide the necessary bias and offset voltage adjustments. The +15 volt supply in the positive sweep circuit could be replaced by a zener diode and a resistor driven from the +43 volt supply. Similar arrangement of two +5 volt LVA diodes is used to derive the bias voltages in the negative sweep amplifier circuit.

III. THE TWO HUNDRED VOLT EXCITER

A. The Switch

The square wave oscillator described in the previous sections of this report was limited to a maximum output signal of eighty volts. This restriction stemmed from the choice and consequently from the availability of complementary transistors with the necessary characteristics to meet the switch requirements. In this section a switching circuit using NPN transistors as the high voltage switches is described. The circuit is capable of driving a 30 pF capacitor over a four volt to a two hundred volt range with 30 ns rise and fall times. At the present time the circuit is restricted to operate at a fixed frequency of one MHz with an adjustable duty cycle between 35 and 60 percent.

The selected higher voltage transistors (UPT430) have a much higher collector to base capacitance than the previously used D40D11 units. Therefore, the total load capacitance for the switch is estimated at 300 pF. To drive this load over a 200 volt range in approximately 50 ns requires a transition current of 1.2 amperes. This current is six times as large as the switching current in the lower voltage system. At the same time, the current gain of the UPT430 transistors is almost an order of magnitude less at that current level than the current gain of the D40D11 units. Therefore, in the previously used configuration, an estimated 600 mA of drive current would be required to switch the transistors and to supply the base to collector capacitance during the transitions. This large transfer current could create complications in the control circuits.

In the new circuit a different approach is employed, from the one used in the previously described eighty volt system, to control the switching

transistors.

The transistors in Figure 5 are driven by MOSFET units located in the emitter circuit. The base to collector capacitances appear between the output terminals and the high voltage supplies. Therefore, they are charged directly through the output circuit and the supplies, without the intervening command transfer elements. Consequently, the driver circuits need no longer drive a portion of the output load while turning the switches on and off.

The recently introduced VMP-1 N-channel enhancement mode power MOSFET simplified the control circuit design. Its ability to switch up to two amperes in less than 10 ns coupled with easy to control switching characteristics, make this unit ideally suited to control the switching transistors.

Three bipolar transistors Q_1 , Q_2 and Q_3 control the MOSFET. With Q_1 off, a 9 volt positive signal from the two floating batteries is applied to the gate of the MOSFET forcing it to conduct. Turning Q_1 on switches the unit off. The bipolar transistors supply sufficient drive for the 30 pF capacitor associated with the gate circuit to switch the VMP-1 in 10 ns. They also absorb currents through C_{DG} capacitance as the UPT430 emitter is driven to its two states.

The required voltage of the floating battery in the base-emitter circuit of the switch is determined by the characteristics of the UPT430 and the VMP-1 transistors. The typical r_{DS} of the VMP-1 device is approximately 2 ohms at the design current of 1.5 amperes. This produces a 3 volt drop between the drain and the source. At this current the V_{BE}

drop of UPT430 is approximately two volts. An additional one volt drop introduced in the battery-capacitor supply circuit is mainly due to inductance. Therefore, a minimum battery voltage of six volts is indicated. Raising that voltage much higher will increase current flow and power dissipation in the VMP-1 transistor without any additional benefits.

The D40D11 transistor reverses the bias on the UPT430 base to emitter junction and thus speeds up the shut-off of the device when the VMP-1 stops conducting. The 1N4148 diode connecting the emitter to the base protects the junction against large reverse bias when Q_4 conducts. This reduces the turn-on delay of the transistor. The diodes D_2 , D_3 and the 6V battery connected between base of Q_3 and the high voltage supply (V_H), also contribute to the speedy shut-off of the UPT430. Once the output voltage reaches within 8 volts of the high voltage supply these diodes start conducting. The gate of the VMP-1 becomes clamped at one diode drop above V_H minus 6 volts. The current in the emitter circuit of the switching transistor is reduced to a very low value. Now the positive voltage switch is ready to be turned off.

The negative voltage switch operation is very similar to the operation just described. The main differences are in the connections to the load and the floating supplies. The collector of the UPT430 drives the load. While in the positive switch the floating batteries were referenced to the output, in the negative voltage switch they are referenced to the slowly variable voltage supply. For that reason, voltages derived from DC-DC converters may be used in the negative voltage circuit, while NiCd batteries,

isolated from the surrounding components to reduce capacitance, are used in the positive voltage switching circuit.

In the construction of the switch component selection and placement must be carefully considered. It must be remembered that each pF of capacitance requires approximately 7 mA of current to traverse the 200 volt range in under 30 ns. The currents that are being switched on and off in 10 ns by the output transistors approach 1.5A. Each nanohenry of inductance, therefore, produces 150 millivolt drop. Although the capacitors that shunt batteries and the power supply circuits need only be in the 1 to 2 uF range their inductance must be very low. Most commonly available capacitors have a sufficiently low equivalent series resistance (ESR) to be suitable for this application, but they also have an inductance in the range of 5 to 10 nanohenries. Capacitors having subnanohenry inductance are available and should be used to bypass the supplies. Interconnections between components must be kept as short as possible since each centimeter of solid wire introduces approximately 0.5 nH of inductance.

To satisfy the requirements of low capacitance, low inductance and heat dissipation in the output circuits, the UPT430 must be placed on a heat sink which, of course, introduces additional capacitance. The emitter of this transistor and the drain of VMP-1 must be connected with a very short length of wire, while the battery bypass capacitor must be placed between the source and the base of the two devices. While these components must be very near each other, the collector of UPT430 and the drain of VMP-1 must be kept at a reasonable distance from other components. The same

is true for the floating NiCd batteries powering the UPT430-VMP-1 circuit.

Performance of such a switch which was constructed as a breadboard for laboratory evaluation without the benefit of the bypass capacitors with very low inductance, can be seen in figures 6 through 9. It should be noted that the variation of the duty cycle visible in the different photographs is due entirely to the control signal and not to the response of the switch.

B. Switch Control

Optically coupled isolators are used to transmit signals from the ground referenced signal generator circuits to the floating switch control transistors. The signal waveform generating and the duty cycle control circuits have been described previously in conjunction with the eighty volt switch. An additional circuit to suppress switching transients has been interposed between the optical isolators and the switch control circuits in the two hundred volt switch.

During the transitions of the output waveform transients also appear in the optical circuits. These erroneous signals due to the capacitance between the input and the output of the isolators affect the operation of the switch. To remove these effects a circuit shown in Figure 10 is placed after each optical isolator. Once the command to switch is received through the optics, this circuit takes control of the switches. Both monostables switch at the same time. The first unit produces a 900 ns pulse which disables the input circuits of the second monostable for that duration. The second monostable produces 100 ns pulse to control the high voltage switches. Since the transitions between the two extreme voltages of the output waveform take less than 50 ns, the control pulse provides more than adequate time for the output to reach its final state. This type of control also provides sufficient time for the switching transistors, which were conducting, to shut-off before the other switch is turned on. At the current levels which can be expected to flow during the mass spectrometer operation the droop in the output waveform with the switch off is negligible.

To achieve highly selective mass filtering the duty cycle of the quadrupole exciter must be maintained near 0.4. Therefore, at one MHz, the longest interval between two commands to switch is near 600 ns. It has been observed that the feedback transients introduced into the optics due to output voltage transitions may last as long as 200 ns. For that reason, the duration of the disabling pulse applied to the input circuit of the monostable controlling the switches must be greater than 800 ns. Since no provisions have been included to vary the duration of the disabling pulse, the operating frequency must remain fixed at one MHz. This, of course, could be changed simply by an introduction of a switch to vary the pulse duration in accordance with the selection of a different operating frequency.

C. Sweep Voltage Circuits

The two sweep signal amplifiers must provide voltages of opposite polarity ranging from two volts to one hundred volts to the switching circuits. A maximum average current of 50 mA also must be supplied to the switches. Circuits shown in Figure 11 have been built to meet these requirements and to test the operation of the switches with a simulated quadrupole load.

The amplitude and the rate of change of the sweep signal are limited at the input of the buffer amplifier by the RC filter and the zener diode respectively. To allow for a fast reset sweep the input resistor is shunted by the diode. The buffer drives two opposite polarity sweep amplifiers consisting in each case of an operational amplifier augmented by transistor circuits to provide the necessary output capabilities. In both circuits the output stages are connected in a modified totem pole configuration where either the upper or the lower Darlington pair supplies the output current at a time. The capacitors and the resistors connected between the base and the emitter of the upper Darlington circuits improve the response of the amplifier. To translate the output of the operational amplifier to the supply voltage level of -110 volts the PNP transistor is used in the negative sweep circuit. Since the lower Darlington circuit of the positive sweep amplifier is referenced to ground, direct drive of the output stage by the operational amplifier is used in that circuit.

IV. SUMMARY OF OTHER WORK

A. Circuits for an Experiment to Control Vehicle Potential

During its flight through the ionosphere a vehicle acquires a negative charge. The resulting potential difference between the vehicle and the surrounding plasma may influence the outcome of some experiments. Therefore, in some instances it would be desirable to maintain the payload at the plasma potential while the experiments are in progress. To demonstrate the feasibility of vehicle neutralization an experiment has been successfully carried out by Dr. C. Sherman of Air Force Cambridge Research Laboratories in which the payload was driven to a positive potential during a flight. This was accomplished by emitting a current of low energy electrons from the rocket. The circuits to control the main thermal emission system were supplied by Northeastern University.

A simplified block diagram of the instrument is shown in Figure 12. An electron gun consisting of an indirectly heated cathode (K), three accelerating grids (G_1 , G_2 and G_3) and a screen grid formed the main thermal emission system. The cathode was cycled between -40.5 volts and +0.5 volts with respect to the vehicle by the cathode bias source. The bias signal made linear transitions between the two voltages in approximately half a second and rested at each of the extreme values for two seconds. The accelerating grids were kept at a constant potential. Therefore, the accelerating grids moved from zero to +50 volts with respect to the screen grid during each cycle of the cathode bias waveform. The screen grid was maintained at the vehicle potential. Thus the flow of the electrons into the plasma was controlled.

Three currents were measured. The source current meter measured that

portion of the cathode current which had a return path through the screen grid or the plasma. The cathode current returning through the accelerator grids was excluded from this measurement. Currents returning from the screen grid and from the skin of the vehicle were measured by the screen grid and the difference current meters respectively. To minimize interference from currents flowing through stray capacitances a bias voltage was supplied to a guard shield.

The source and the grid current meters were implemented using operational amplifiers. Logarithmic amplifier measured the difference current. The cathode bias voltage sweep was generated by a high voltage operational amplifier connected to perform integration. The integrator was clamped at two voltages to obtain the desired trapezoidal waveform. To eliminate current paths other than through the meters, the commands for the bias circuit to move from one to the other extreme of the bias voltage were transmitted through the optically coupled isolator.

Details of the electronics for the control of the emission and of the current meters are given in a previous report.²

B. Bias Circuits for a Mass Spectrometer in SWIR Experiment

Bias and signal processing circuits have been designed and built for a mass spectrometer successfully flown as a part of the project EXCEDE: SWIR experiment.⁶ The experiment consists of an electron accelerator, a number of optical and infrared sensors and a positive ion mass spectrometer launched as a single payload into a night atmosphere. The rocket-based electron accelerator irradiates the atmosphere at altitudes of 100 to 110 kilometers with one second duration current pulses. In the process quantities of positive ions are produced and may be measured by the existing rocket mass spectrometers.

The injection of the electrons into the atmosphere by the electron gun causes a buildup of a positive charge on the payload and consequently on the mass spectrometer. Unless neutralized the positive potential would limit the measurement capability of the instrument. To overcome this limitation a negative bias voltage with respect to the vehicle was applied to the front plate of the mass spectrometer.

The bias signal continuously switched through -31V, -62V, -125V and -250V and remained at each voltage level through six complete mass filter sweeps over the desired atomic mass unit range. Smooth transitions of approximately 200 millisecond duration were incorporated into the signals. Pulses equal in duration to the transitions were provided to switch the mass spectrometer into the total ions mode. Bias voltage for the other components of the mass spectrometer followed the waveform of the front plate bias signal. This variable bias schedule allowed to observe the performance of the mass spectrometer under the various vehicle potential,

bias voltage and the electron gun activity conditions.

The front plate bias circuits included a dc-dc converter and a series-shunt regulator. The quadrupole rod common (Comm Q) bias and the bias to all other components of the mass filter were supplied from two separate regulators. The power for these circuits was obtained from the main converter of the instrument.

Four current signals were processed for transmission through the telemetry link. The information about the net input flux of positive ions and electrons was obtained from a current originating at the aperture plate of the mass filter. The mass spectrum information was carried by two currents representing different levels of detection sensitivity. One of these currents was obtained from the output of the electron multiplier structure while the other originated at a grid as a positive current.

All three of the latter signals required logarithmic current-to-voltage converters. The multiplier current meter was referenced to the payload and processed a negative current in the 10^{-11} to 10^{-6} ampere range. The grid current meter was referenced to the variable negative bias source and processed positive current in the 10^{-11} to 10^{-6} ampere range. Bipolar current processing in the range of 10^{-8} to 10^{-3} amperes was required of the aperture plate circuit, which also was referenced to the variable bias voltage. The last two current meters contained circuits to translate the signals from the bias reference level to the payload level for transmission through the telemetry link. The front plate bias current was also monitored.

The detailed description of the bias control, the regulator and the signal processing circuits is given in reference 3 .

The mass spectrometer performed well during the flight. Although the vehicle reached only 99 kilometers instead of the expected 108, valuable data nevertheless was received.⁶ The instrument was destroyed when the recovery system of the vehicle failed.

C. Modifications in Mass Spectrometer Electronics

A number of existing electronic subassemblies for airborne mass spectrometers were modified to meet the specific requirements of several upper atmosphere composition measurement experiments. Mass spectrometer control and test instruments for laboratory and field use were built. Field services to prepare and to launch some of the instruments were provided.

The basic mass spectrometer electronic assemblies were designed and built by Tri-Con Associates Inc. for AFCRL. These instruments contained RF and dc voltage generators for the excitation of the quadrupole mass filters, a programmer for the control of the exciter and data signal conditioners in the form of an electrometer amplifiers or a pulse counter. Instruments intended for measurements of neutral species also contained filament emission control for an ionizing source. A multi-output power converter supplied the necessary voltages to operate the circuits from a single 28V dc source. To adapt these units to the specific dictates of each experiment required adjustment and modification of the existing circuits as well as the design and the assembly of additional circuitry.

A total of 13 units, including the mass spectrometer for the SWIR experiment, were modified. These units included four positive ion/neutral switchable instruments, eight positive ion, one negative ion and one positive/negative ion switchable units. This number includes instruments which were originally modified and flown, recovered, refurbished and then flown again.

In general, modifications and/or adjustments were required in almost every electronic subassembly. Some of the modifications were routinely

performed on all of the instruments and could be included as a part of the basic instrument in future designs. The two most obvious were the relay position monitors and the RF bypass capacitors. The capacitors were placed on the power terminals of the operational amplifiers in the RF oscillator control section and on the output stages of the dc sweep amplifiers. Without these capacitors it was practically impossible to maintain the required dc to RF ratio in the quadrupole excitation signal over a reasonable amu sweep range. Other modifications, which were also performed on every instrument but were tailored to a particular application, included the wiring-programming of the amu sweep schedule and the adjustment of the turns ratio of the output coil in the RF oscillator to meet the amu range requirements.

Among the circuits that were added to the various instruments were the emission regulators (for the positive ion/neutral switchable units only), fixed and variable bias circuits for the quadrupole front end grid structures, electrometer signal conditioning circuits and instrument performance monitors. Vacuum ion pump power supply and monitor circuits were built and installed into the high altitude instruments.

Three control units for the mass spectrometer electronics were built. One unit was constructed for laboratory use. The other two were built into briefcases for field operations. A number of smaller test units were also constructed to be used during the subassembly check-out and adjustment procedures.

A total of seven man field support missions were undertaken. These field operations were necessary either for systems checks or for a preparation and the launch of a mass spectrometer.

PERSONNEL

A list of the engineers, technicians and student assistants who contributed to the work reported is given below:

J. Spencer Rochefort, Professor of Electrical Engineering, Principal Investigator (on sabbatical leave to University of Alaska, Fairbanks, Alaska, from 1 Sept. 74 to 30 June 75).

Raimundas Sukys, Senior Research Associate, Engineer (acting Principal Investigator from 1 Aug. 74 to 31 July 75).

Steven Goldberg, Research Assistant, Engineer.

Harry Tweed, Technician, Electrical Engineering.

Thomas Palasek, Cooperative Research Fellow (Project Assistant through 28 June 76).

Gerard Reilly, Project Assistant.

RELATED CONTRACTS AND PUBLICATIONS

F19628-74-C-0042
F19628-76-C-0256

1 September 1973 through 31 July 1976
1 July 1976 through present

Sukys, R. and Goldberg, S. (1974), "Control Circuits for a Rocket Payload Neutralization Experiment and Other Topics", Scientific Report No. 1, AFCRL-TR-74-0580.

Sukys, R., Rochefort, J. S. and Goldberg, S. (1975), "Bias and Signal Processing Circuits for a Mass Spectrometer in the Project EXCEDE: SWIR Experiment", Scientific Report No. 2, AFGL-TR-76-0060.

REFERENCES

1. Richards, J. A., Huey, R. M. and Hiller, J. (1973), "A New Operating Mode for the Quadrupole Mass Filter", International Journal of Mass Spectrometry and Ion Physics, Vol 12, No. 4.
2. Sukys, R. and Goldberg, S. (1974), "Control Circuits for a Rocket Payload Neutralization and Other Topics", AFCRL-TR-74-0580.
3. Sukys, R., Rochefort, J. S. and Goldberg, S. (1975), "Bias and Signal Processing Circuits for a Mass Spectrometer in the Project EXCEDE: SWIR Experiment", AFGL-TR-76-0060.
4. Sherman, C. (1975), "Vehicle Potential Control by Means of Electron Emission", AFCRL-TR-75-0445.
5. O'Neil, R. R., Lee, E. T. P., Huppi, E. R., and Stair, A. T. Jr. (1973), "Project EXCEDE: SWIR Experiment", AFCRL-TR-73-0152.
6. O'Neil, R. R., Stair, A. T. Jr., Ulwick, J. C., Burt, D. and Narcisi, R. (1976), "EXCEDE: SWIR experiment", Quick Look Data Report.

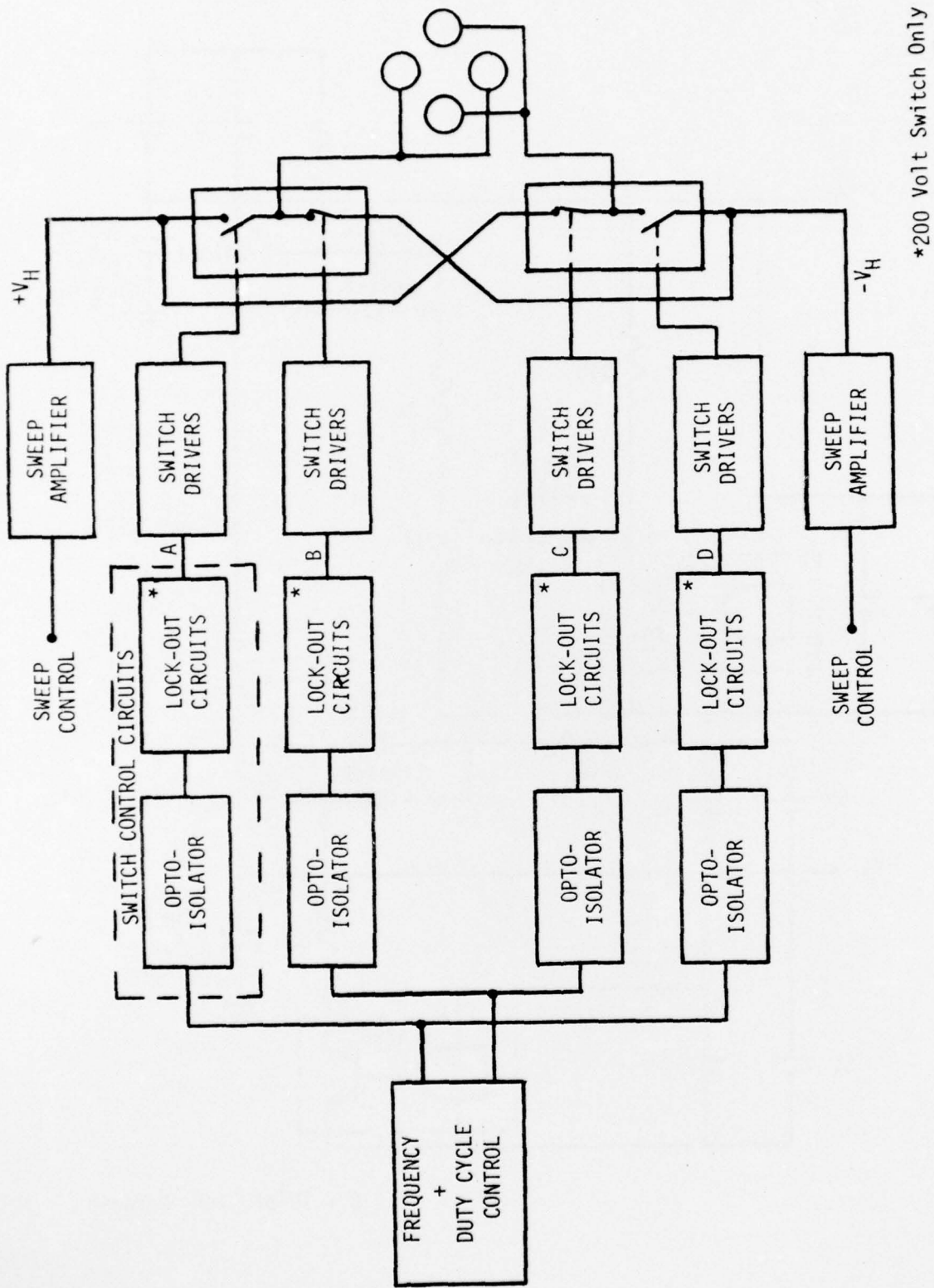

Figure 1. Block Diagram of Quadrupole Exciter

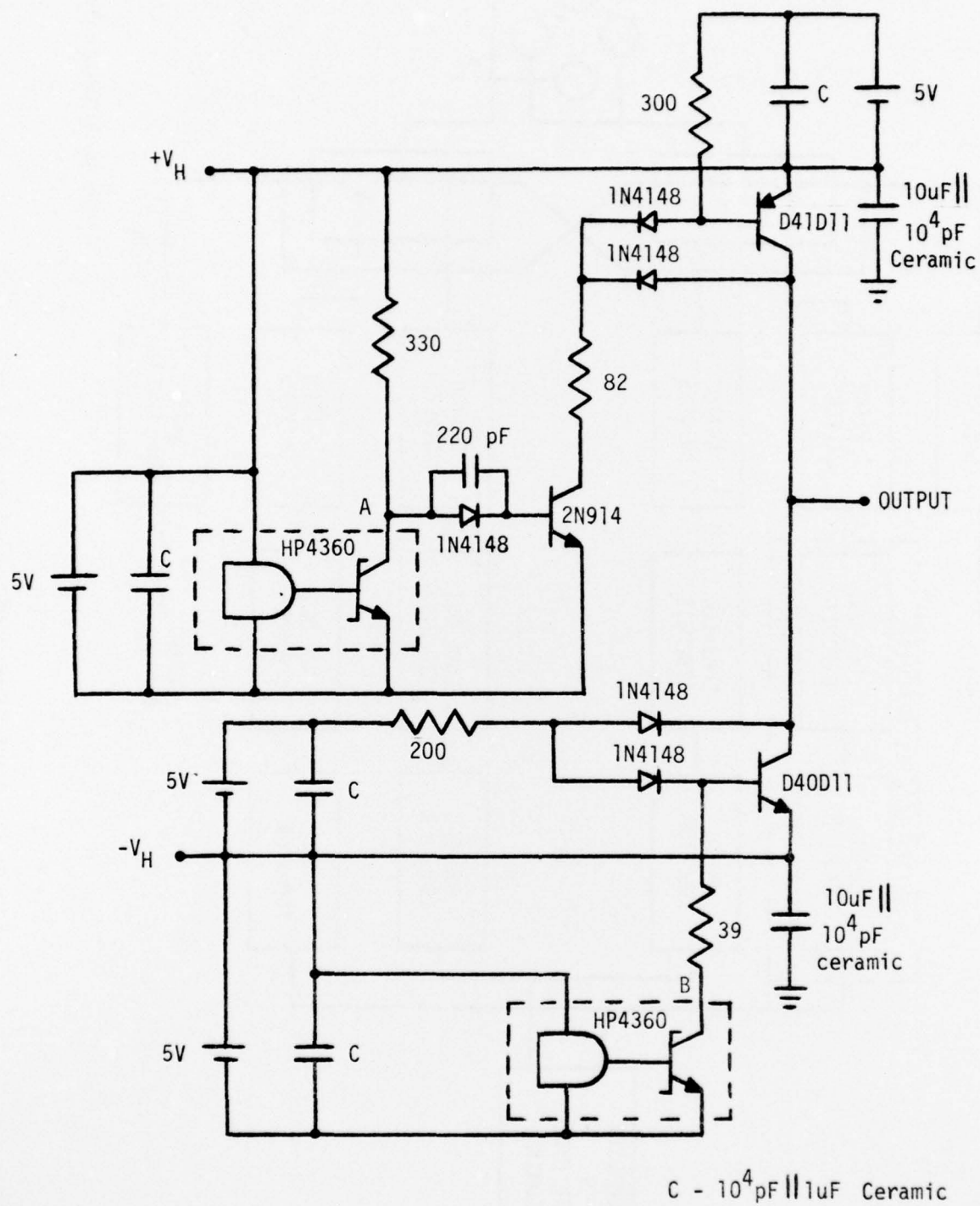

Figure 2. The 80 Volt Switch

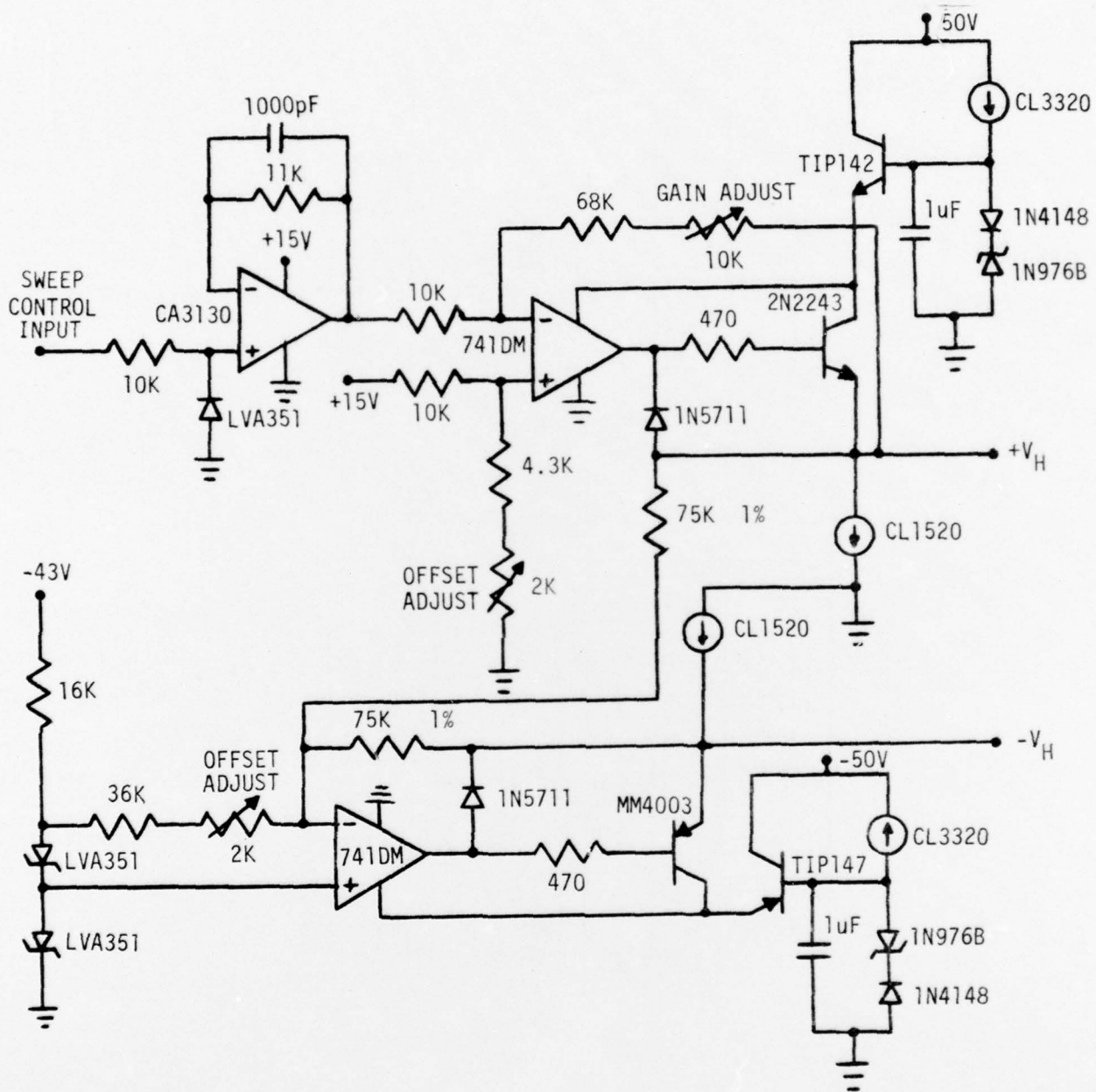
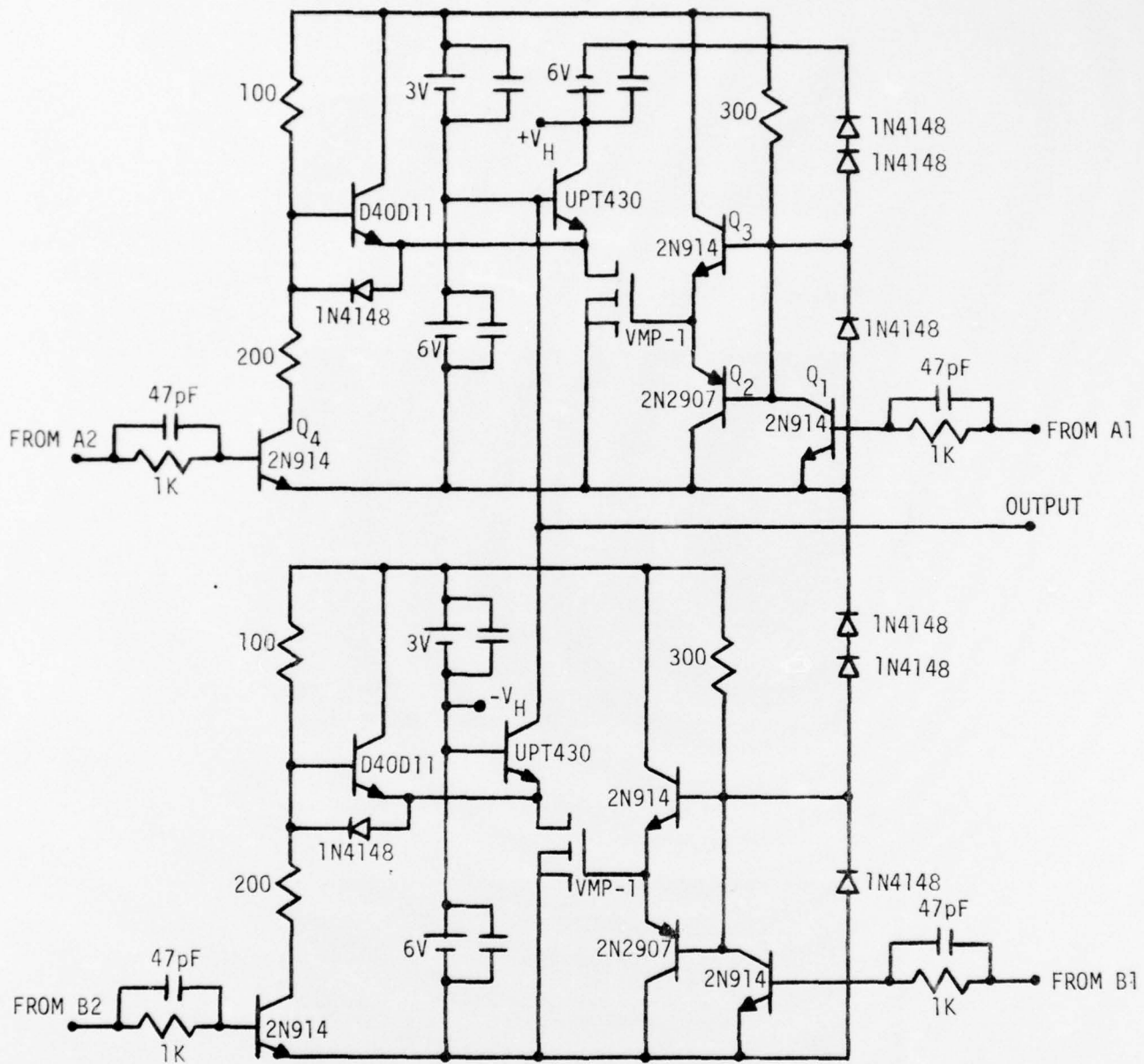

Figure 4. Supply Voltage Sweep Amplifiers



Note: All resistors are in ohms and all capacitors are 1uF unless otherwise noted.

Figure 5. The 200 Volt Switch

1
V
O
L
T
/
D
I
V

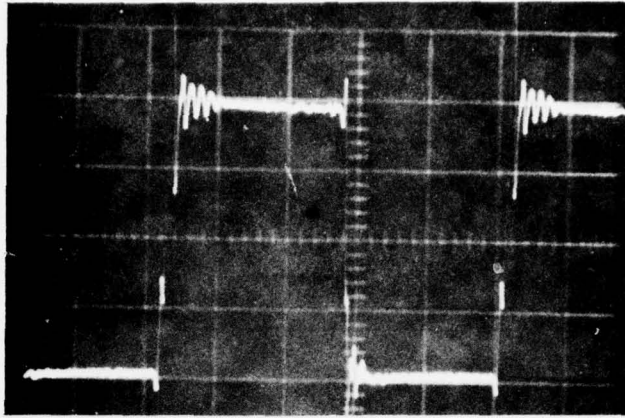

200 NSEC/DIV

Figure 6. Output Waveform at Four Volts

2
0
V
O
L
T
S
/
D
I
V

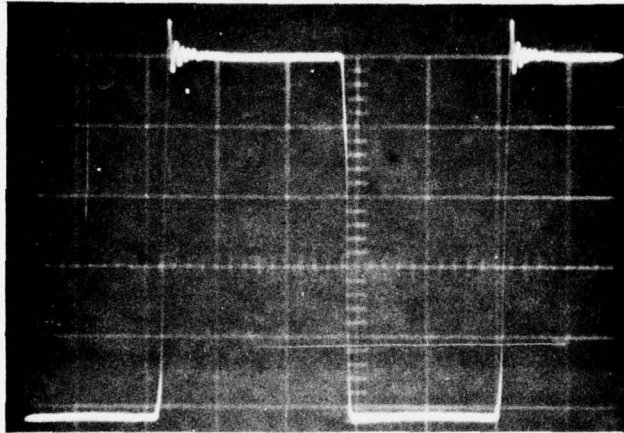

200 NSEC/DIV

Figure 7. Output Waveform at Hundred Volts

5
0
V
O
L
T
S
/
D
I
V

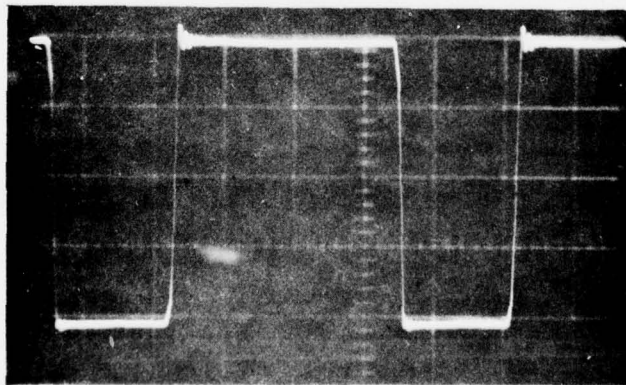

200 NSEC/DIV

Figure 8. Output Waveform at Two Hundred Volts

50 VOLTS / DIV

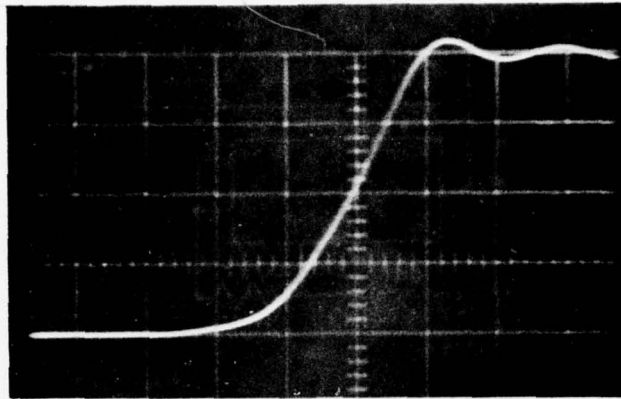

10 NSEC/DIV

50 VOLTS / DIV

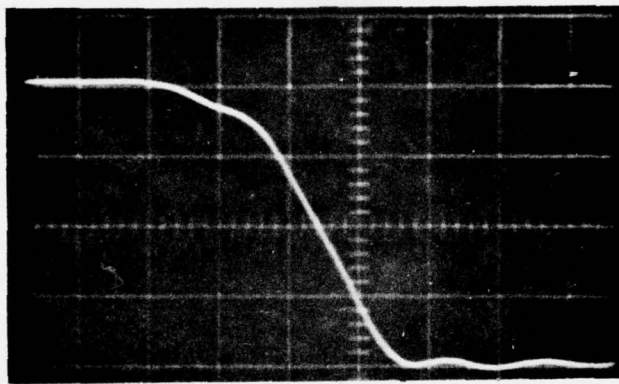

10 NSEC/DIV

Figure 9. Rise and Fall Times at Two Hundred Volts

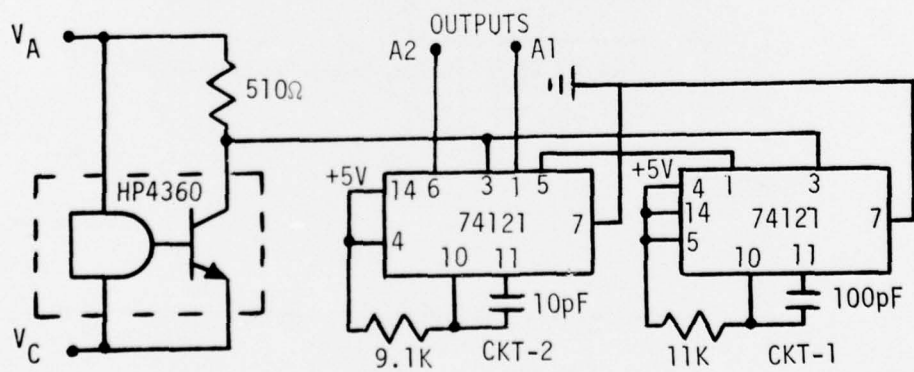

Figure 10. Switch Control Circuit

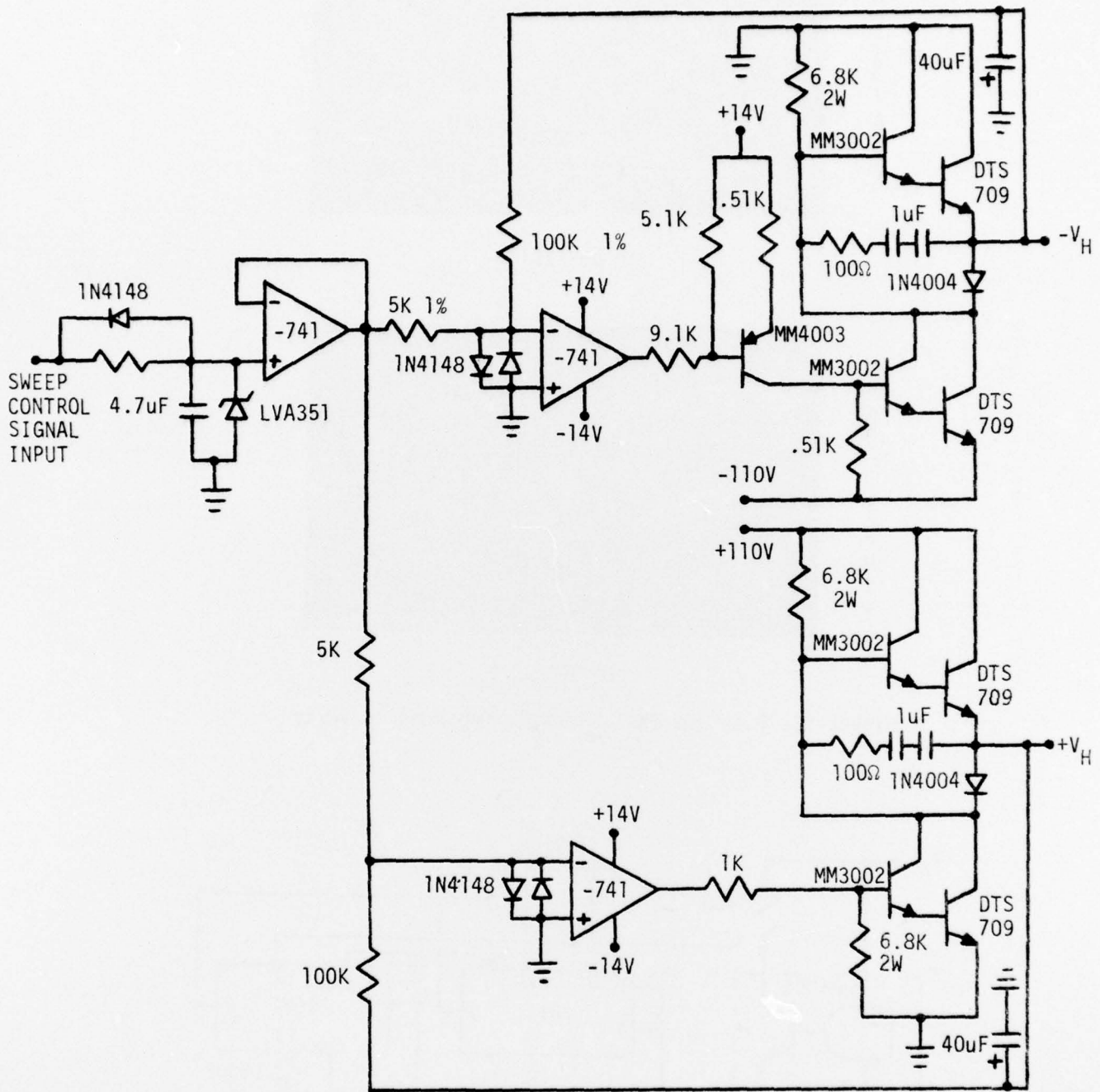

Figure 11. Sweep Amplifiers

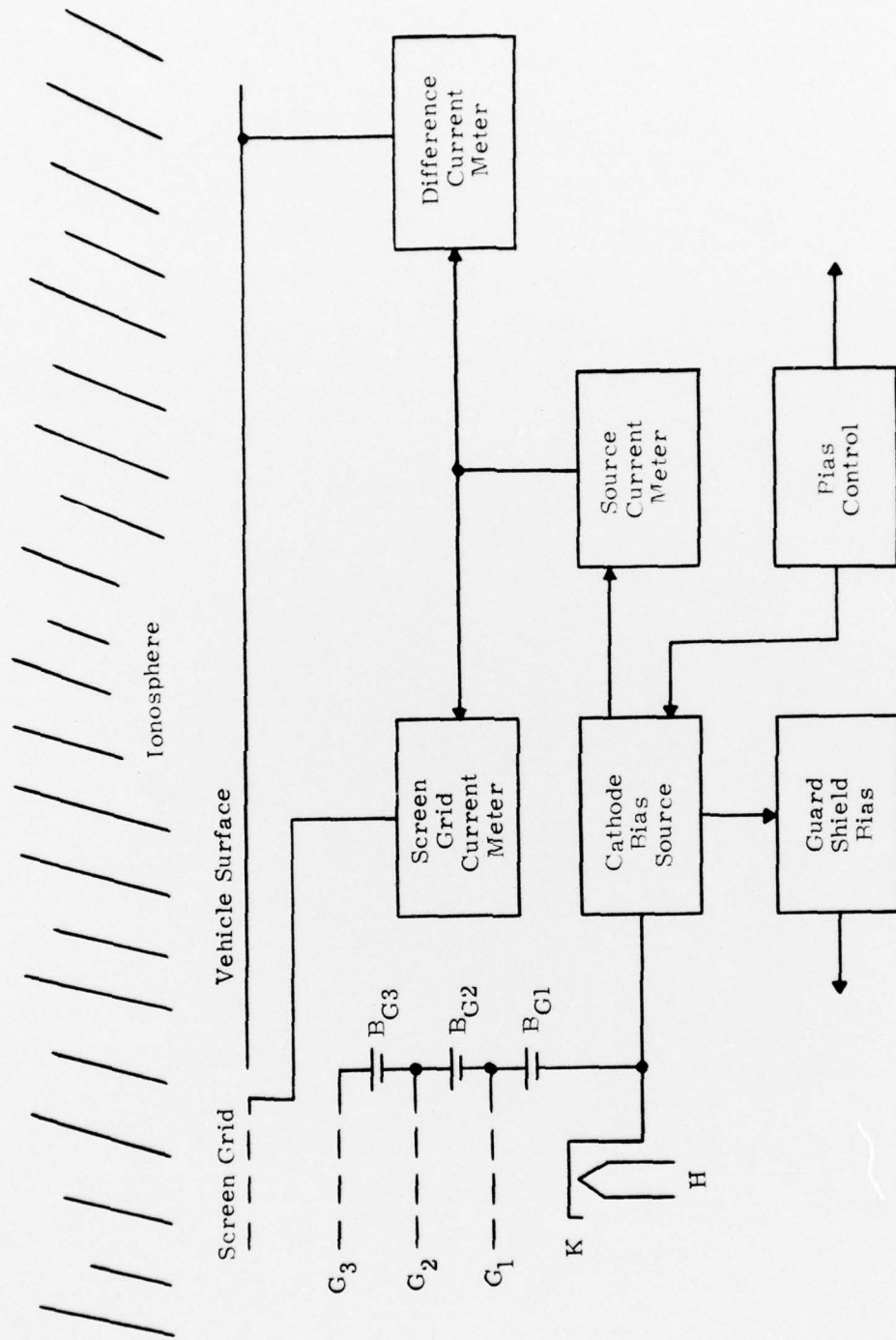

Figure 12. Vehicle Potential Control Experiment Diagram