

AD-A032 495

ARMY ELECTRONICS COMMAND FORT MONMOUTH N J
FAST ELECTRONIC TUNING OF HIGH POWER CIRCUITS FOR UHF POWER AMP--ETC(U)
OCT 76 G C FINCKE
ECOM-4445

F/G 9/5

UNCLASSIFIED

NL

1 OF 1

AD A032495



END

DATE
FILMED
1 - 77



12

FL

AD A 032495

Research and Development Technical Report

ECOM-4445

FAST ELECTRONIC TUNING OF HIGH POWER CIRCUITS FOR UHF POWER AMPLIFIER

George C. Fincke

Electronics Technology & Devices Laboratory

October 1976

DDC
RECEIVED
NOV 23 1976
C

DISTRIBUTION STATEMENT

APPROVED FOR PUBLIC RELEASE;
DISTRIBUTION UNLIMITED

ECOM

US ARMY ELECTRONICS COMMAND FORT MONMOUTH, NEW JERSEY 07703

NOTICES

Disclaimers

The findings in this report are not to be construed as an official Department of the Army position, unless so designated by other authorized documents.

The citation of trade names and names of manufacturers in this report is not to be construed as official Government indorsement or approval of commercial products or services referenced herein.

Disposition

Destroy this report when it is no longer needed. Do not return it to the originator.

Unclassified

SECURITY CLASSIFICATION OF THIS PAGE (When Data Entered)

REPORT DOCUMENTATION PAGE		READ INSTRUCTIONS BEFORE COMPLETING FORM
1. REPORT NUMBER ECOM-1445	2. GOVT ACCESSION NO.	3. RECIPIENT'S CATALOG NUMBER
4. TITLE (and Subtitle) Fast Electronic Tuning of High Power Circuits for UHF Power Amplifier	5. TYPE OF REPORT & PERIOD COVERED Technical Report, General	6. PERFORMING ORG. REPORT NUMBER
7. AUTHOR(s) George C. Fincke	8. CONTRACT OR GRANT NUMBER(s)	
9. PERFORMING ORGANIZATION NAME AND ADDRESS US Army Electronics Command ATTN: DRSEL-TL-BS Fort Monmouth, N.J. 07703	10. PROGRAM ELEMENT, PROJECT, TASK AREA & WORK UNIT NUMBERS 1S762705AH94 B3	
11. CONTROLLING OFFICE NAME AND ADDRESS US Army Electronics Command ATTN: DRSEL-TL-B Fort Monmouth, N.J. 07703	12. REPORT DATE October 1976	
14. MONITORING AGENCY NAME & ADDRESS (if different from Controlling Office) 1219p.	13. NUMBER OF PAGES 15	15. SECURITY CLASS. (of this report) Unclassified
16. DISTRIBUTION STATEMENT (of this Report) Approved for public release; distribution unlimited.		
17. DISTRIBUTION STATEMENT (of the abstract entered in Block 20, if different from Report)		
18. SUPPLEMENTARY NOTES		
19. KEY WORDS (Continue on reverse side if necessary and identify by block number) Triode Electronic Tuning Coaxial-Cavity Power Combiner PIN Diodes		
20. ABSTRACT (Continue on reverse side if necessary and identify by block number) A technique was developed for fast tuning (one microsecond) a coaxial cavity power amplifier to utilize the several advantages of narrowband power over an octave frequency range at UHF. The method described incorporates PIN diodes and is similar to that previously developed for VHF power output systems. Power output and frequency range objectives were not achieved due to the choice of a conventional pi-network output circuit. An improved output circuit is proposed in order to meet design goals for power output and frequency		

037620 AB

CONT.

UNCLASSIFIED

SECURITY CLASSIFICATION OF THIS PAGE(When Data Entered)

BLOCK #20 (Contd.)

range. This fast-tuning technique, applied to a multiplexer-power combiner, is suggested as a method of overcoming the three decibels of power loss usually associated with the use of binary wideband hybrid combiners for multi-tone operation.

ACCESSION for

NTIS
DGC
UNANNOUNCED
JUSTIFICATION

BY DISTRIBUTION AVAILABILITY CODES

DECL. MAIL. DATE OF SIGNAL

A

UNCLASSIFIED

SECURITY CLASSIFICATION OF THIS PAGE(When Data Entered)

CONTENTS

	Page
INTRODUCTION	1
TECHNICAL APPROACH	1
TEST RESULTS	7
CONCLUSIONS	10
REFERENCES	11
APPENDIX A - Multiplexer-Power Combiner System	12
APPENDIX B - Time-Frequency-Diversity Power Amplifiers	14

FIGURES

1. Coaxial-Cavity And Tuning Circuit	2
2. Coaxial-Cavity And Tuning Circuit (Section View at Spoke Level)	3
3. Cavity Spoke Equivalent Circuit	6
4. Frequency Switching Diagrams (a) and (b)	8
5. Cathode Input Circuit (Side Section View)	9
A-1. Multiplexer-Power Combiner	13
B-1. Time-Frequency-Diversity Power Amplifiers	14

FAST ELECTRONIC TUNING OF HIGH POWER CIRCUITS FOR UHF POWER AMPLIFIER

INTRODUCTION

Broadband frequency power amplifiers have been extensively used for EW, radar, and communication applications in recent years. However, wide instantaneous bandwidth amplifiers suffer from low DC/RF conversion efficiency and poor rejection of spurious, harmonic, and IM products. More recently, multiple transistor, power module amplifiers have been developed for one kilowatt (kW) average output and 40 percent bandwidth at UHF. Although module efficiency has been somewhat improved over the older broadband amplifiers, i.e., from 10 to 30 percent, intermodulation distortion and harmonics still remain at the previous -20 to -30 decibel (dB) level.

In order to solve problems of low efficiency and unwanted emissions in broadband systems, a new electronic switching technique was devised for rapidly tuning (one microsecond) high power tube circuits over a wide frequency range (more than one octave at VHF and 40 percent bandwidth at UHF.) A summary of the VHF and UHF programs was published in the IEEE Transactions on Circuits and Systems dated March 1974.¹ In response to an ECM system requirement, a four-tone design for 1.5 kW per tone and 60 percent frequency range at VHF was developed and demonstrated by a commercial laboratory.² Also, an objective design for 700 watts of average output within 1 dB over a 16 percent range at UHF was developed at US Army Electronics Command (ECOM) and reported in January 1974.³ An additional ECM system requirement for 250 watts of output over a frequency range of 450-900 megahertz (MHz) has been investigated in recent months at ECOM, and the results of this program are reported.

TECHNICAL APPROACH

For the VHF broadband systems, a multiple of PIN diodes was located at discrete points along either a strip-line, or helix anode tank circuit and switched on, one at a time, to vary the line length and thus the inductive susceptance of the circuit. For UHF, a TEM mode, coaxial-cavity circuit was designed. The present circuit incorporates twelve radial, inductive spokes located at the low impedance (output) end of the cavity and switched into the circuit with PIN diodes in a variety of combinations. (See Figures 1 and 2.) The cavity characteristic impedance was designed for 43 ohms. This, together with 4 picofarads (pF) of output capacitance from a type 8940 power tube, resulted in a bandwidth shrinkage factor ($K = f \frac{Z_0}{X_C}$) of 1.40 to 2.00.

1. G. C. Fincke, "Fast Electronic Tuning of High-Power Circuits for VHF-UHF Power Amplifiers," IEEE Transactions on Circuits and Systems, Vol. CAS-21, No. 2, March 1974.
2. Private communication with GTE Sylvania.
3. G. C. Fincke, "Fast Electronic Tuning of High Power Circuits for UHF Power Amplifiers," ECOM Memorandum, 30 January 1974.

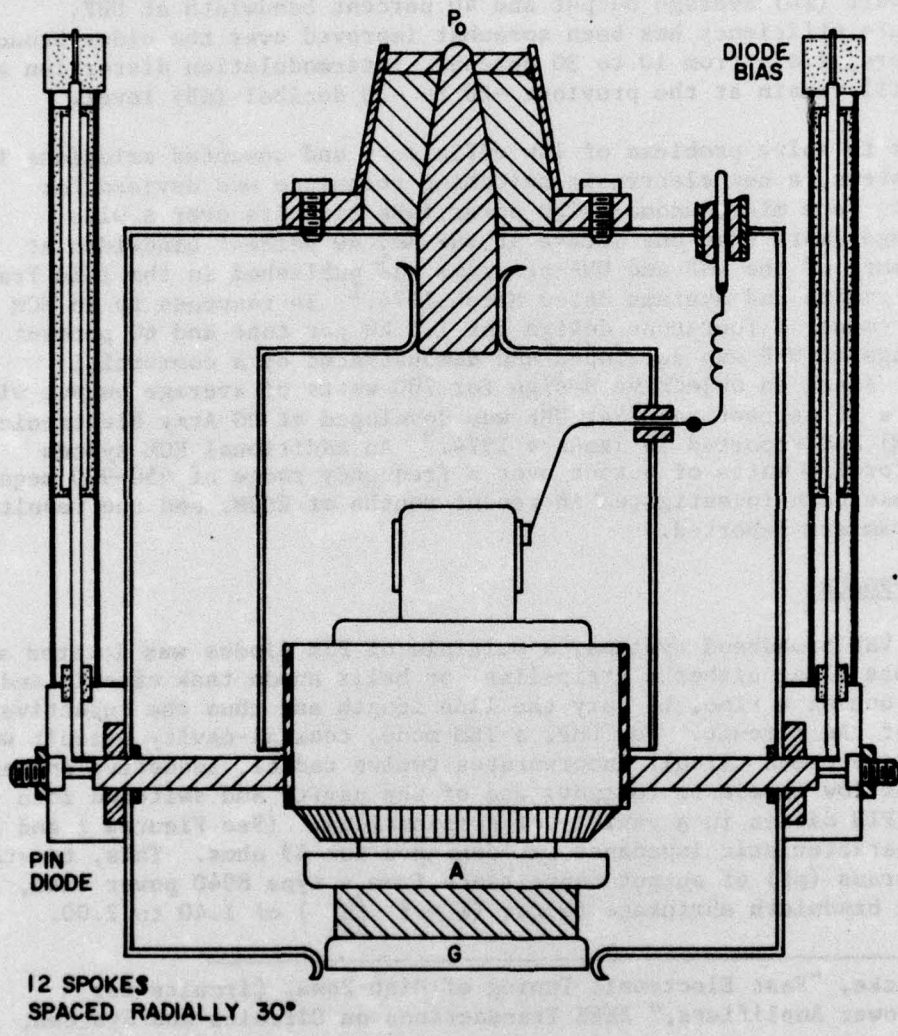

ELEVATION

Figure 1. Coaxial-Cavity And Tuning Circuit

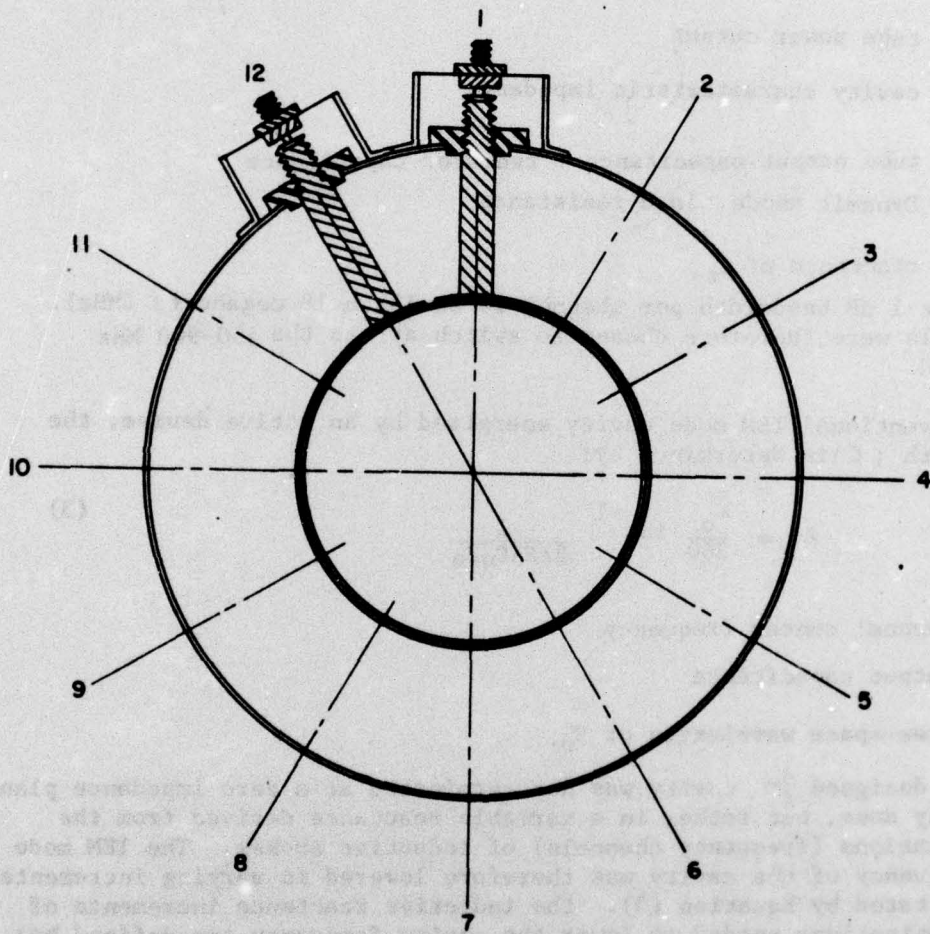

(Section View At Spoke Level)

Figure 2. Coaxial-Cavity And Tuning Circuit

The required 250 watt power level combined with the shrinkage factor and the following tube limits,

$$\frac{E_p^2}{R_o} = P_o(t) BW \quad (1)$$

$$(-3dB)BW = \frac{1}{2\pi R_o C_t} \quad (2)$$

where

E_p = RMS plate voltage

$P_o(t)$ = tube power output

Z_o = cavity characteristic impedance

C_t = tube output capacitance + radiator capacitance

R_o = Dynamic anode load resistance

X_c = reactance of C_t ,

determined the 1 dB bandwidth per channel to be 13 to 18 megahertz (MHz). Thirty channels were therefore chosen to switch across the 450-900 MHz frequency band.

In a conventional TEM mode cavity energized by an active device, the physical length (ℓ) is determined by:

$$\ell = \frac{\lambda_o}{360} \tan^{-1} \frac{1}{2\pi F_o C_o Z_o} \quad (3)$$

where,

F_o = channel center frequency

C_o = output capacitance

λ_o = free-space wavelength of F_o .

However, the designed $\frac{\lambda}{4}$ cavity was not terminated at a zero impedance plane as is normally done, but rather in a variable reactance derived from the thirty combinations (frequency channels) of inductive spokes. The TEM mode resonant frequency of the cavity was therefore lowered in varying increments from that dictated by Equation (3). The inductive reactance increments of the spoke combinations needed to lower the cavity frequency are defined by:

$$X_L = \frac{Z_o}{2} \tan^{-1} \frac{\ell_r 180}{\lambda_o} \quad (4)$$

where,

$$\ell_r = \frac{\lambda}{2} \quad (\text{at high frequency end of band}).$$

Also, since the variable combined reactance of the several spokes presented a common terminal impedance to both the resonant cavity and the output coupling line, the resonant frequency and the coupling coefficient were switched in synchronism. The cavity-spoke circuit was therefore treated as a semi-distributed-element, pi-network as shown in Figure 3. The circuit "Q" is given by the following equation:

$$\frac{R_o}{X_c} = Q_L = \frac{X_c}{R_a} \quad \text{where, } R_a = \frac{R_L X_L^2}{R_L^2 + X_L^2} \quad (5)$$

The frequency determining elements of the combined circuit were then considered to be: C_o , ℓ , Z and X_L . The variable reactance, X_L , was defined by the lengths and diameters of the individual spokes and the several combinations of them together with their mutual inductances. Vernier adjustment of the channel frequency was accomplished by trimming the $\lambda/4$ coaxial bias-isolating chokes for the PIN diodes. The L/C ratio of the choke-PIN diode capacity was chosen to shunt-resonate at the high end of the frequency range so that RF currents in the diodes would be limited in the "off" state.⁴ With an R_o of 800 ohms maintained over the 450-900 MHz frequency band, efficient transfer of power was considered possible with a maximum deviation of 1 decibel.^{5,6}

Although the cavity configuration for the output transmission line shown in Figure 3 proved adequate for the prior 390 MHz, 16 percent frequency range, 700 watt output system, it has not been satisfactory for the new 450-900 MHz frequency range, 250 watt amplifier. The $\lambda/4$ coaxial transition satisfied the requirements for " R_a " over the former 16 percent range but limited the power output to 100 watts, 25 percent efficiency, and a 470-600 MHz frequency band for the latter development. Thus, the full 450-900 MHz range could be tuned by the 12 spokes in their multiple combinations at very low power, but the $R_o \cdot R_a = X_c^2$ coupling factor would not provide the required impedance match at high power for the octave frequency span with a constant impedance, $\lambda/4$ output line. Therefore, a simulated tapered-impedance ($\lambda/4$ at low frequency end of band) transmission line was substituted. Inasmuch as this involved averaging the " R_a " over the 450-900 MHz band, it did not adequately fulfill the requirements of Equation (5) for optimum coupling. From the foregoing theoretical considerations and companion experimental investigations, it was concluded that the pi-network circuit, Figure 3, could not simultaneously satisfy the parameters of Equations (4) and (5) for tuning

4. Private communication with W. N. Parker, RCA.

5. Private communication with R. Bailey, RCA.

6. C. Georgopoulos, PIN Driver Design," Microwaves, Vol. 11, No. 8, August 1972.

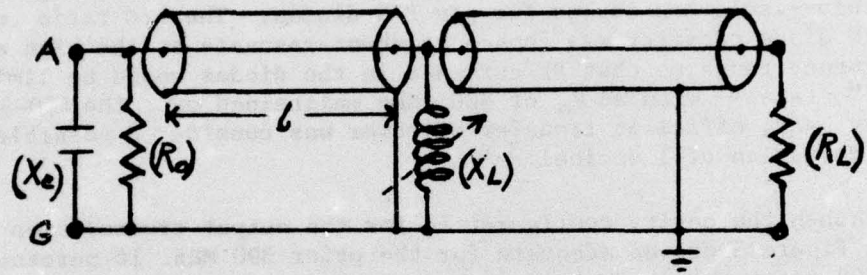

Figure 3. Cavity Spoke Equivalent Circuit

and coupling over the objective 450-900 MHz frequency range. It is considered, however, that the circuit that would adequately accomplish the objectives of this program is one similar in type to that used by the previously mentioned commercial laboratory for 60 percent frequency coverage at VHF and 1500 watts output. This circuit incorporates a broadband, output coupling strip-line, and is depicted as one quadrant of the multiplexer-power combiner circuit of Appendix A of this report.

PIN diodes with the following characteristics were selected for the spoke switching:

$$\begin{aligned}P_{\text{diss}} &= 10\text{W} \\R_{\text{fwd series}} &= 0.600\ \Omega \\V_b &= 1600\ \text{V} \\C &= 1\ \text{pF} \\ \text{Equiv. } R_{\text{shunt}} &\text{ at } -200\ \text{V} = 20\ \text{K}\Omega \\ \text{Bias "On"} &= 1.0\text{V}, 0.250\text{A}.\end{aligned}$$

A reverse bias of 200 volts was applied to the diodes in the "OFF" condition in order to limit leakage to less than 10 microamperes. Manual frequency switching was used for the feasibility model (see Figure 4a.) For one microsecond frequency agility, the circuit of Figure 4b has been suggested.⁶

The cathode drive circuit incorporated a one-half wave, tapered strip-line for broadband transformation to the tube input impedance of 15 ohms (see Figure 5.) A small inductive reactance was provided by the three radial bars of the socket cathode connector for tuning out the 20 pF of tube input capacitance over the frequency band. Forced air cooling was applied to the tube anode through the air system socket, and a small air jet for each diode housing was shunted from the main air stream. Diode stud temperature was therefore limited to 93 degrees centigrade, which is considered adequate for long-term reliable operation.

TEST RESULTS

With six uniformly spaced spokes located at an " ℓ " of 3.18 centimeters (cm), and an additional six spokes located at an " ℓ " of 6.68 cm, a continuous frequency range of 450-900 MHz was covered with the type 8940 tube at low power. Because of the difficulties in maintaining the optimum coupling factor, $R_o \cdot R_a = X_c^2$, the twelve spokes were transferred to a uniform " ℓ " of 5.08 cm with the pi-network circuit (see Figure 3.) With a plate voltage of 850 volts and a plate current of 0.50 amperes, a power output of 104 watts was obtained over a 470-600 MHz frequency range at 25 percent efficiency. These limited-objective results were due to the overriding inadequacy of the " R_a " factor with the pi-network circuits. Power gain was 7 to 9 dB, and the expected intermodulation distortion (IMD) for the type 8940 tube was -30 dB, maximum.

6. C. Georgopoulos, "PIN Driver Design," *Microwaves*, Vol 11, No 8, Aug. 1972.

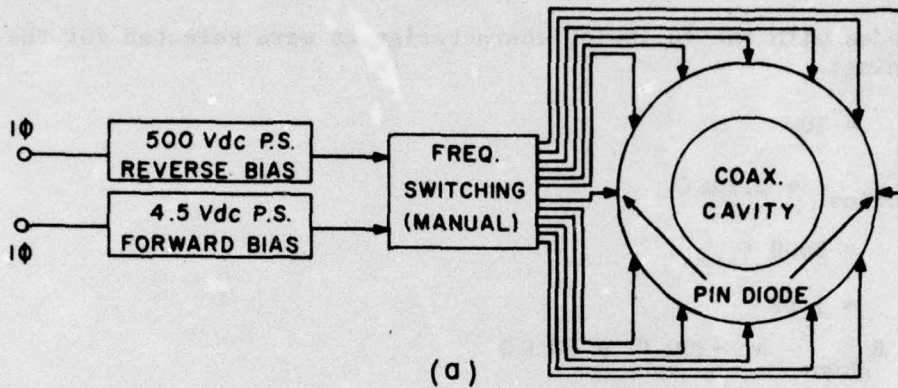

(a)

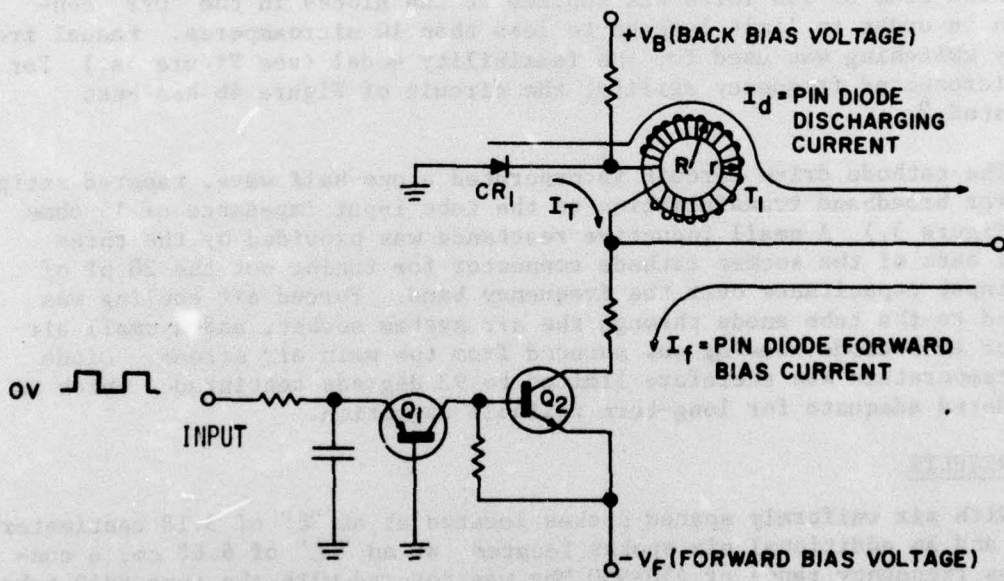

(b)

Figure 4. Frequency Switching Diagrams

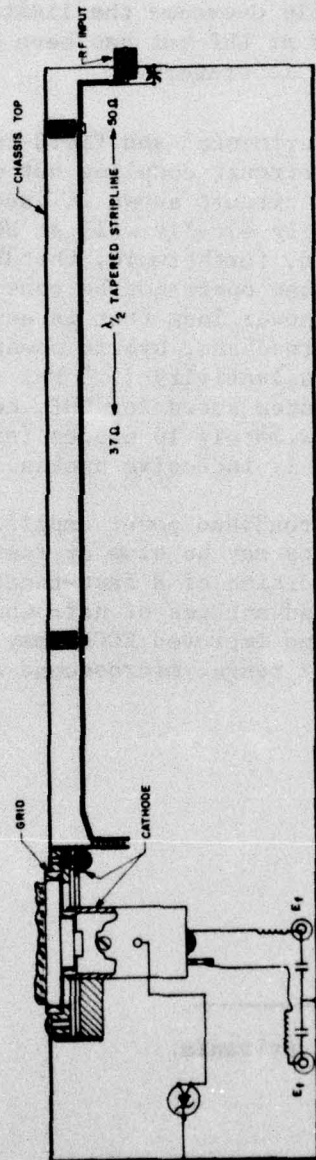

Figure 5. Cathode Input Circuit (Side Section View).

CONCLUSIONS

The feasibility of fast-tuning a high-power coaxial-cavity circuit over an octave frequency range at UHF has been demonstrated. The technique of switching in various combinations of 12 inductive spokes in order to provide the varying inductive reactance to the cavity for tuning and coupling outpower was limited, however, by the pi-network type of output circuit. The coupling coefficient parameter, " R_a ", was found to be too inflexible for the 450-900 MHz frequency range, resulting in an output of only 104 watts over the 470-600 MHz range instead of the expected 250 watts across the whole band. Replacing the pi-network output with a broadband strip-line circuit should effectively overcome the limitations imposed by the former. This was not attempted at UHF but has been successfully accomplished at VHF by a commercial laboratory.²

It is concluded, from the experimental and field-test experience at VHF using a helical strip-line circuit coupling out of a fast-tuned cavity, that the strip-line output circuit shown in quadruplicate in Appendix A of this report would apply equally well at UHF, and beyond to L, S, and C bands. It is suggested, furthermore, that the multiplexer-power combiner circuit for multi-tone operation be considered as a method of overcoming the basic six dB of power loss that is associated with the use of traditional, dual-staged, broadband, hybrid power combiners. An order of magnitude improvement in selectivity (1.5 MHz channels), over that expected from the 12-spoke system shown for UHF, could be made available by the addition of approximately 10 diodes for switching-in capacitors in conjunction with the 12 inductive spokes.

It is suggested, also, that broadband power amplifier (EBS tubes, TWT's, or power transistors) outputs may be slow or fast-tuned with microsecond frequency agility by the addition of a fast-tuned-filter as outlined in Appendix B. Thus, the several advantages of narrowband output (low broadband noise, harmonics, IMD, and improved ECCM) may be achieved concurrently with very large frequency range, microsecond diversity, power systems.

2. Private communication with GTE Sylvania.

REFERENCES

1. G. C. Fincke, "Fast Electronic Tuning of High-Power Circuits for VHF-UHF Power Amplifiers," IEEE Transactions on Circuits and Systems, Vol. CAS-21, No. 2, March 1974.
2. Private communication with GTE Sylvania.
3. G. C. Fincke, "Fast Electronic Tuning of High Power Circuits for UHF Power Amplifier," ECOM Memorandum, 30 January 1974.
4. Private communication with W. N. Parker, RCA.
5. Private communication with R. Bailey, RCA.
6. C. Georgopoulos, "PIN Driver Design," Microwaves, Vol. 11, No. 8, August 1972.

APPENDIX A

MULTIPLEXER-POWER COMBINER SYSTEM

The basic technique for multiplexing several frequencies and combining them into a common load with good isolation properties is described below.

The example depicts a four-tone (carrier-frequency) system. However, the multiplexing-combining system may be applied to a multiple of frequencies, of two or more, by modifying the number of tuned circuits that make-up the overall combiner module.

An RF power signal, F_1 , is applied to the coaxial terminal, Amplifier #1 Input (see Figure A-1,) and to the input of the tuned coaxial-cavity filter. A strip-line coupler parallels the tuned coaxial-cavity filter along its axis, and couples out 3 dB of the power. The remaining 3 dB of RF power, not coupled to the strip-line, travels down the coaxial filter in a TEM mode, and is reflected back to its origin in phase addition when the appropriate inductive spokes are switched "on" by the PIN diodes at $\lambda/4$. Thus, the two power components are added in the strip-line coupler as determined by the diode-tuned inductive spokes. Since the strip-line comprises one-fourth of the outside wall of a centrally located, 50 ohm, coaxial cavity "core" of the combiner, the total F_1 power, minus a maximum 1 dB of filter insertion loss, is therefore transferred to the 50 ohm combiner output via the "core" cavity. In like manner, F_2 , F_3 , and F_4 power signals applied to each respective quadrant tuned filter-coupler, have their powers transformed and transferred to the respective quadrants of the 50 ohm, "core" cavity and combined with each other and F_1 at the 50 ohm, combiner output terminal. Since the tuned $\lambda/4$ filters operate reciprocally, a minimum of 15 dB of isolation between individual signals is to be expected.

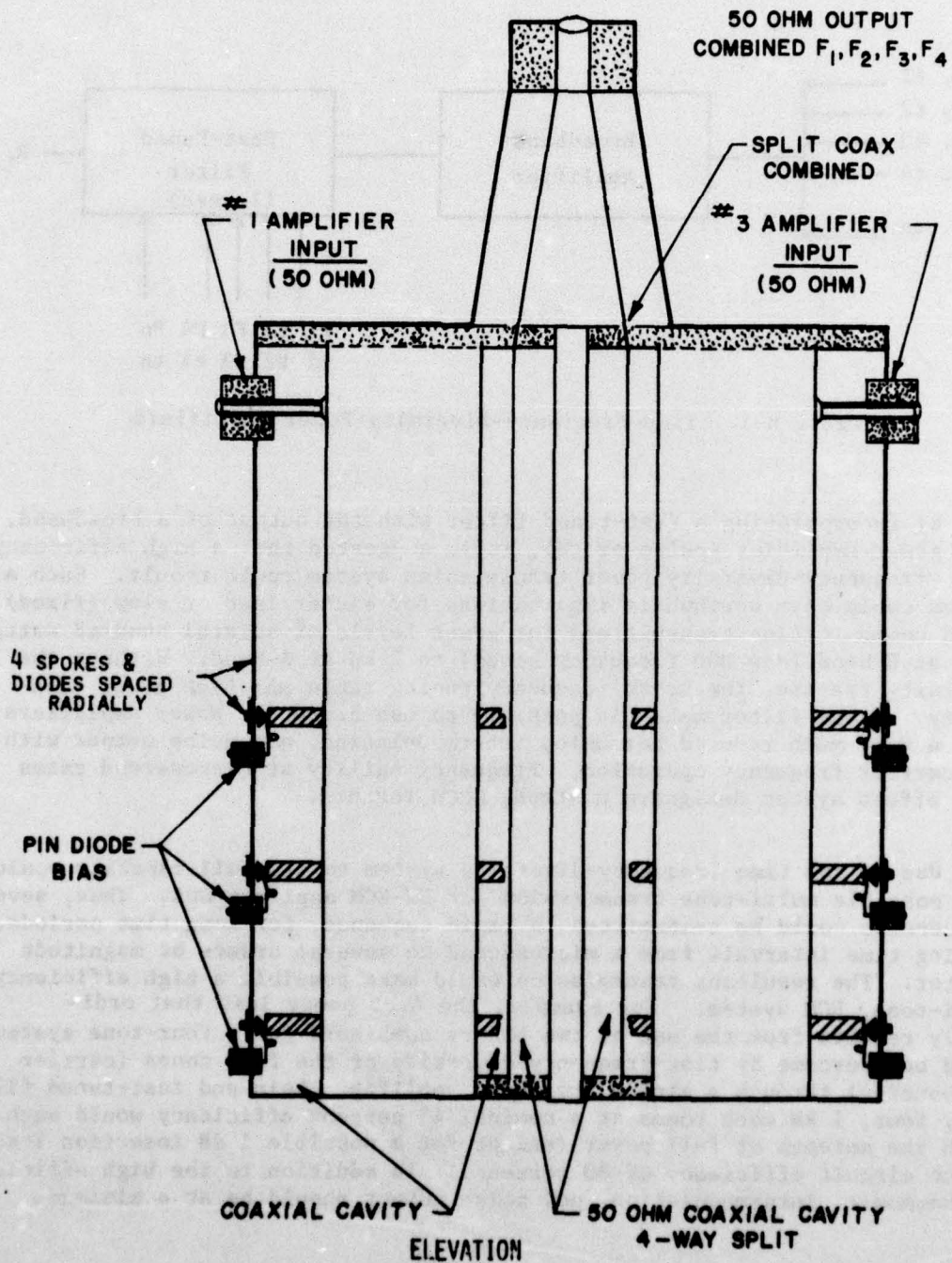

Figure A-1. Multiplexer-Power Combiner

APPENDIX B

TIME-FREQUENCY-DIVERSITY POWER AMPLIFIERS

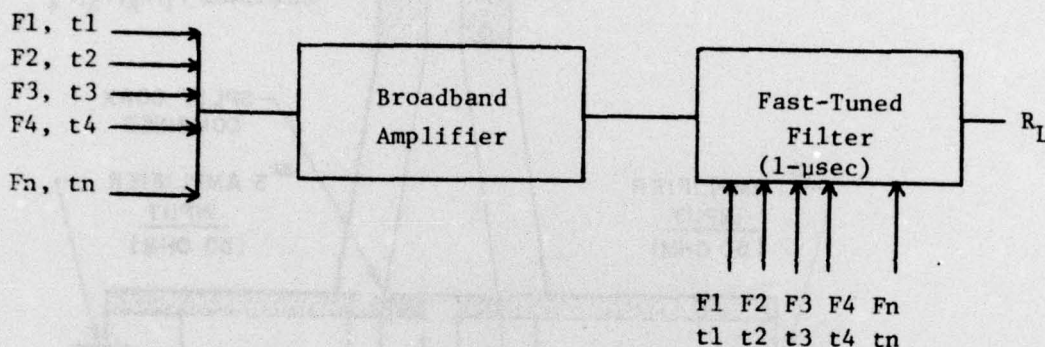

Figure B-1. Time-Frequency-Diversity Power Amplifiers

By incorporating a fast-tuned filter with the output of a broadband, high power amplifier (pulse or CW), it is suggested that a high efficiency, time-frequency-diversity power transmission system could result. Such a system could have worthwhile implications for either fast or slow (fixed) tuned communication transmitters for power levels of several hundred watts (CW) at C-band (new DOD frequency bands) to 2 kW at A-band. Without the diversity feature, the broad frequency tuning range and high power capability of the filter makes it possible to use broadband power amplifiers with a very much reduced harmonic, intermodulation, and noise output with one carrier frequency operation. Frequency agility at microsecond rates also offers system designers a strong ECCM feature.

Use of the time-frequency-diversity system to its full capacity would make possible multi-tone transmission for EW-ECM applications. Thus, several frequencies could be transmitted in rapid sequence, for long time periods, at varying time intervals from a microsecond to several orders of magnitude greater. The resultant transmission would make possible a high efficiency, multi-tone, ECM system. For example, the 6 dB power loss that ordinarily results from the use of two binary combiners for a four-tone system could be overcome by time-frequency-diversity of the four tones (carrier frequencies) through a single broadband amplifier chain and fast-tuned filter. Thus, four, 1 kW each tones at a nominal 45 percent efficiency would each reach the antenna at full power (except for a possible 1 dB insertion loss due to circuit efficiency of 80 percent.) In addition to the high efficiency, the harmonic, intermodulation, and noise output should be at a minimum.

The fast-tuned filter suggested for this system could be one of a variety of fast-tuned circuits similar in operation to those described and evaluated in Electronics Technology and Devices Laboratory Notebook Number KL-669, pages 16, 17, and 20 through 49 and Laboratory Book Number TL-254, pages 1 through 14, and 16 through 18 and in Patent Application SN 497788, filed 15 August 1974, entitled, "Fast Electronic Tuning of High Power Circuits for VHF-UHF Power Amplifiers at High Efficiency."