

AD-A032 581

ELECTRONICS ENGINEERING GROUP (1842ND) RICHARDS-GEBAU--ETC F/G 17/2
A LOCAL AREA TEST CENTER.(U)

JUL 76 K C MORTON, D B METTERS, V P ARAFILES
1842 EEG/EPECW-TR-77-3

UNCLASSIFIED

NL

1 of 1
AD
A032581



END

DATE
FILMED
2-77

AD A 032581

10

NOV 26 1976
RECEIVED
C

DISTRIBUTION STATEMENT A
Approved for public release;
Distribution Unlimited

THE UNIVERSITY OF MICHIGAN LIBRARY
ANN ARBOR, MICHIGAN 48106

Unclassified

SECURITY CLASSIFICATION OF THIS PAGE (When Data Entered)

REPORT DOCUMENTATION PAGE		READ INSTRUCTIONS BEFORE COMPLETING FORM
1. REPORT NUMBER 14 1842 EEG/EPECW-TR-77-3	2. GOVT ACCESSION NO.	3. RECIPIENT'S CATALOG NUMBER
4. TITLE (and Subtitle) 6 A Local Area Test Center.		5. TYPE OF REPORT & PERIOD COVERED 9 Technical rept.,
7. AUTHOR(s) 10 Keith C. Morton, P.E., Electronics Engineer Dahl B. Metters, Maj., USAF, EE Virgilio P. Arafiles, 1st Lt. USAF, EE		6. PERFORMING ORG. REPORT NUMBER
9. PERFORMING ORGANIZATION NAME AND ADDRESS 1842 EEG/EPE/AFCS Richards-Gebaur AFB, MO 64030		B. CONTRACT OR GRANT NUMBER(s)
11. CONTROLLING OFFICE NAME AND ADDRESS Wire Systems Branch 1842 EEG/EPECW Richards-Gebaur AFB, MO 64030		10. PROGRAM ELEMENT, PROJECT, TASK AREA & WORK UNIT NUMBERS 12 23 P.
14. MONITORING AGENCY NAME & ADDRESS (if different from Controlling Office) Wire Systems Branch 1842 EEG/EPECW Richards-Gebaur AFB, MO 64030	12. REPORT DATE 11 15 Jul 76	13. NUMBER OF PAGES 29
	15. SECURITY CLASS. (of this report) Unclassified	15a. DECLASSIFICATION/DOWNGRADING SCHEDULE
16. DISTRIBUTION STATEMENT (of this Report) Approved for public release. Distribution unlimited.		
17. DISTRIBUTION STATEMENT (of the abstract entered in Block 20, if different from Report)		
18. SUPPLEMENTARY NOTES None		
19. KEY WORDS (Continue on reverse side if necessary and identify by block number) None		
20. ABSTRACT (Continue on reverse side if necessary and identify by block number) The increasing demand for the transmission of widely disparate and complex communications signals over the base communication system will continue to place enormous loads upon the base cable plant as well as the operations and maintenance personnel involved. This report describes the various alternatives that may be applied to solve this growing problem.		

DD C
 RECEIVED
 NOV 26 1976
 RECEIVED
 C

APPROVAL PAGE

This report has been reviewed and is approved for publication and distribution.

Leo J. Cormier

LEO J. CORMIER
Acting Chief, Communications Engineering Div

Thomas H. Weaver, Jr.

THOMAS H. WEAVER, JR.
Chief, Switching Section

Keith C. Morton

KEITH C. MORTON, P.E.
Electronics Engineer

Dahl B. Metters

DAHL B. METTERS, MAJ, USAF
Electronics Engineer

Virgilio P. Arafiles

VIRGILIO P. ARAFILES, 1LT, USAF
Electronics Engineer

APPROVED BY	DATE	BY	DATE
BY	EXTENSION/AVAILABILITY STATUS	NO.	AVAIL. SER. OR SERIAL
A			

SUMMARY

The increasing demand for the transmission of widely disparate and complex communications signals over the base communications system will continue to place enormous loads upon the base cable plant as well as the operations and maintenance personnel involved.

As a result of these increasing demands, an expressed requirement exists for an on-base cable plant performance monitoring system.

This paper describes the various alternatives that may be applied to solve this growing problem. A solution is advanced by the concept described in this paper as the Local Area Test Center (LATC).

TABLE OF CONTENTS

<u>Para No.</u>		<u>Page</u>
1.	BACKGROUND	1
1.1	General	1
1.2	Technical Considerations	3
2.	ALTERNATIVES	3
2.1	General	3
2.2	Present Method	3
2.3	Other Manual Methods	4
2.3.1	Intrabase Communications Test Facility (ICTF)	4
2.3.2	Commercial Systems	4
2.4	Automated Methods	4
2.4.1	Automated Tech Control (ATEC)	4
2.4.2	Commercial Automated Systems	5
2.4.3	Computer Controlled Systems	5
2.4.4	Local Area Test Center (LATC)	5
2.5	Comparison of Alternatives	5
3.	LATC BLOCK DIAGRAM DESCRIPTION	7
3.1	Basic Configuration	7
3.2	LATC Expansion	7
3.3	LATC Physical Layout	12
3.4	LATC Operation and Maintenance	12
3.4.1	Automatic Mode of Operation	12

TABLE OF CONTENTS (CON'T)

3.4.2	Semi-Automatic Mode of Operation	12
3.4.3	Manual Mode of Operation	14
3.4.4	Test Repertoire	14
4.	TYPICAL INTRABASE CIRCUIT	14
4.1	LATC Interface Description	14
4.2	LATC Reliability	16
4.3	Intended Applications	16
5.	RECOMMENDATIONS	16
6.	REFERENCES	17

LIST OF ILLUSTRATIONS

<u>Figure No.</u>	<u>Title</u>	<u>Page</u>
1	Facilities Requiring Testing (Situation)	2
2	Comparison of Alternatives	6
3	Local Area Test Center, Block Diagram	8
4	Matrix	9
5	Central Control Panel (CCP)	10
6	LATC Expansion	11
7	LATC Proposed Layout	13
8	Typical Intrabase Circuit	15

1. BACKGROUND

1.1 General. Computer ADP systems have introduced a proliferation of data circuits on many Air Force bases. As illustrated in Figure 1, many operational circuits and automatic tie lines by-pass the main and intermediate distribution frames. As a result, the common test point is no longer an integral part of the overall base communications system. Many facilities, particularly the data and other dedicated or critical circuits, either lack test points or are physically separated from the common test point. Many of the newer systems require new test techniques.

1.1.1 Consequently, the 1842 EEG has developed the necessary cable diagnostic tests which are sufficient to isolate and correct cable related problems.

It has been established that base cable plants, if properly conditioned and maintained, are capable of satisfying transmission requirements in the 50 kilobit area and, in many cases, up to 10 megabits (RADC TR-258, Vol II Digital Cable System Handbook, Sep 74). Accordingly, several programs have also been implemented in an effort to improve the condition of the overall base communications system from both a management and technical viewpoint. One of these, the cable assessment program (SCOPE CAP), verified that inadequate maintenance can seriously impair the capability of the cable plant to satisfy such requirements. SCOPE CAP also established that manual testing techniques were unreliable in that inconsistencies or inconclusive results are achieved. Along with being labor intensive, manual testing performed by many different technicians with various levels of skill coupled with inadequate records, was a prime contributor to overall unsatisfactory results.

1.1.2 Another program, Central Office Performance Evaluation (COPE), also established that inadequate base cable maintenance can severely limit the inherent capabilities of switches and terminal equipment. AFCS is responsible for the maintenance of government-owned base cable plants. Within these base cable plants are critical circuits that require special attention. Presently, the majority of Air Force bases have from 50 to 500 data circuits, plus other critical circuits. Present trends indicate that the numbers

SITUATION

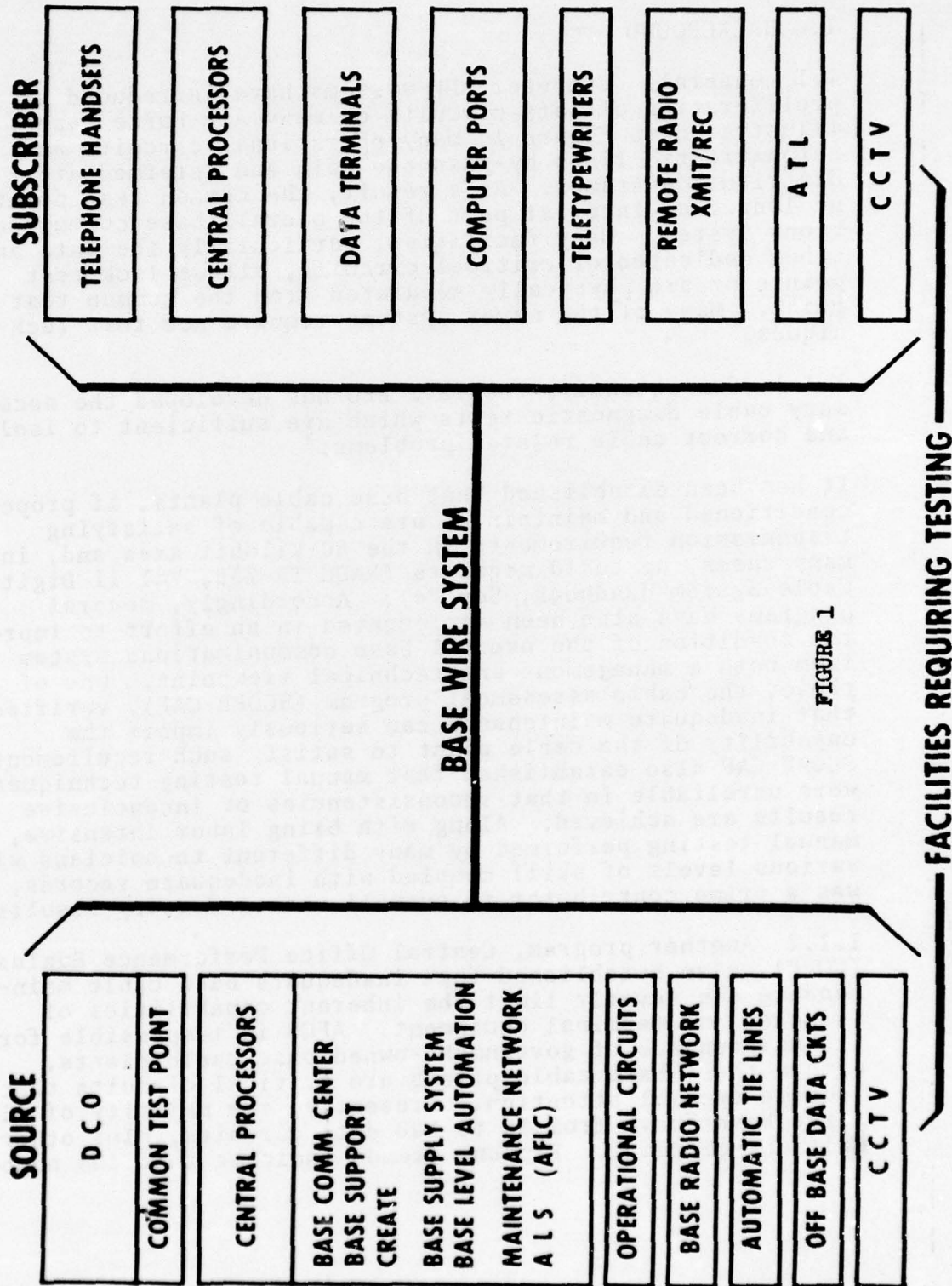

FIGURE 1

of these circuits will increase. The local communications squadron, which is responsible for installing and maintaining such critical circuits, has a limited capability to carry out these responsibilities. A system must be identified to meet the requirements of AFCS for the performance assessment, fault isolation and maintenance of critical on-base circuits.

1.2 Technical Considerations. Any system to be used for maintenance of on-base cable circuits must have certain basic capabilities. Some means of accessing critical circuits within the cable plant must be provided. This could be accomplished manually or automatically. When installing a circuit some means of checking circuit conditioning and verifying the capability of the circuit to pass the required traffic must be provided. If performance monitoring is to be accomplished, some routine tests must be performed. To correct faulty circuits, some diagnostic tests must be accomplished.

2. ALTERNATIVES

2.1 General. There are three general classes of systems which can be used for circuit maintenance. These are:

- a. The present method
- b. Other manual methods
- c. Automated methods

2.2 Present Method. In the case of the present methods, the local Communications Squadron or the Comm Area presently handles installation of critical circuits. To check out the circuits, the local Communications Squadron or the Area installation team can run relatively simple tests for normal voice parameters using available equipment and tests developed by the SCOPE CAP program. However, to check other more complex parameters, assistance from the 1839 EIG at Keesler AFB is usually required. For instance, in the maintenance area, if a problem surfaces on a circuit, the local Communications Squadron can find some problems such as opens or shorts, but if the customer complains of high error rates, assistance from the 1839 EIG will most likely be required. The present system does work, but it has several disadvantages; such as:

2.2.1 Response time is very long except for simple problems.

2.2.2 The system is costly since it requires TDY travel and shipment of test equipment.

2.2.3 Though the local Communications Squadron has the limited test equipment capability required to perform some of the necessary tests, they do not, in many locations, have the skills required to operate and interpret the equipment readings.

2.3 Other Manual Methods. Manual systems to access and test the base cable plant fall into two categories, the Intrabase Cable Test Facility (ICTF) proposed by Computer Sciences Corporation (CSC) and various commercially available systems.

2.3.1 Intrabase Communications Test Facility (ICTF). The ICTF consists of up to seven racks of manually operated test equipment and manual patching facilities. The ICTF is a high cost, labor intensive system and must be operated by highly skilled technicians.

2.3.2 Commercial Systems. Systems using manually operated commercial test equipment and manual patching facilities could be acquired but would cost approximately as much as the ICTF and would also require the skilled people. The major problem with manual systems is that test results vary depending upon the operator. This fact was amply demonstrated during the SCOPE CAP program. When the costs of the equipment and the personnel costs are added together, a very high price is paid for a manual system.

2.4 Automated Methods

2.4.1 Automated Tech Control (ATEC). ATEC consists of several stand-alone facilities plus a nucleus facility. To perform the required cable testing functions, three of these stand-alone facilities would be required; i.e., the In-Service Quality Monitoring, the Out-of-Service Quality Monitoring and the Digital Distortion Monitoring Facilities. Each of these facilities contains a separate minicomputer. ATEC is a system specifically orientated for the long-haul DCS circuits and, as such, it is not economically adaptable for an intrabase application. The ATEC system (as it is now defined) possesses many capabilities which would not be used in a base cable testing facility.

2.4.2. Commercial Automated Systems. Typical of a commercially available automatic system is the calculator controlled Hewlett Packard system. This system can be tied to an IIP desk calculator to make up an automated test system. To perform the functions required on the base cable plant, it is estimated that a system of this type would cost approximately \$71,000 for the test equipment, access, and calculator. Not all required test functions can be done with this type system; the major disadvantage is that if a new test is required, usually a new piece of test equipment must be purchased.

2.4.3 Computer Controlled Systems. Computer controlled communication test instruments characterize the communications circuit in terms of basic parameters. These systems can be made to test the circuits on an out-of-service basis and give go-no-go indications. However, they tend to be very expensive systems which have more capability than is needed for intrabase application. Many of these systems also require a skilled operator.

2.4.4. Local Area Test Center (LATC) The Local Area Test Center concept is being proposed as a cost-effective system to test and monitor critical circuits. Figure 1 shows a typical situation where the LATC would be applied. The LATC is being designed for use by unskilled operators and to perform some of the logic required to troubleshoot a circuit problem.

2.5 Comparison of Alternatives. Figure 2 is a comparison of the different methods that can be used for on-base communications circuit performance monitoring and maintenance. They are:

- a. Cost of the basic equipment (minimum configuration).
- b. Skill of the equipment operator.
- c. Space that equipment requires.
- d. Time required to discover a circuit problem and repair it.
- e. Flexibility - The ease with which a new test may be added to the system, i.e., would a new piece of test equipment be required:

Type of System	Equipment Cost	Skill Requirements	Rack Space	Time to Repair	Flexibility	Total Cost
Present Manual	Low	Low	-	Long	Low	High
ICTF Commercial Automatic	100K+ 100K+	High High	7 1-7	Medium Medium	Low Low	High High
ATEC Computer Calculator	200K+ 100K+ 71K+	High Low-High Medium	3-4 1+ 1+	Short Short Short	High High Low	High Med-High Medium
LATC	30K	Low	1	Short	High	Low

COMPARISON OF ALTERNATIVES

Figure 2

f. Total cost of the system, which includes the basic equipment, training of the operator, and in the case of the present method, the TDY costs. (The cost of the lost computer time could also be added.)

3. LATC BLOCK DIAGRAM DESCRIPTION.

3.1 Basic Configuration. The basic configuration of the LATC is shown in Figures 3, 4 and 5 and consist of:

- a. A Switching Matrix, used to route incoming or outgoing circuits to individual test units.
- b. A Digitally Controlled Analog Filter, used to measure the power in a selected frequency.
- c. An Analog-To-Digital Converter, used to convert input, analog voltages to digital words.
- d. A Digital-To-Analog Converter, used to convert digital words to output, analog voltages.
- e. A Frequency Synthesizer, used to generate frequencies of interest and is controlled by digital words.
- f. A test Modem Capability for performance of Bit Error Rate (BER) tests.
- g. A Mini-Computer, used to control all other units. In the final version of the LATC, the minicomputer may be replaced with a less expensive microprocessor.
- h. A Mass Storage Device, such as a disk, cassette tape system, or 9-track tape recorder is used for program storage and long term statistical information for trending purpose.
- i. A Cathode Ray Tube (CRT) Terminal, used to communicate with the LATC system.
- j. As an option, the LATC is configured for a printer which will produce a hard-copy output.

3.2 LATC Expansion. Figure 6 is an illustration of the LATC expansion capability. Figure 6A is configured for 4680 4-wire circuits. In Figure 6B the basic LATC has been expanded in

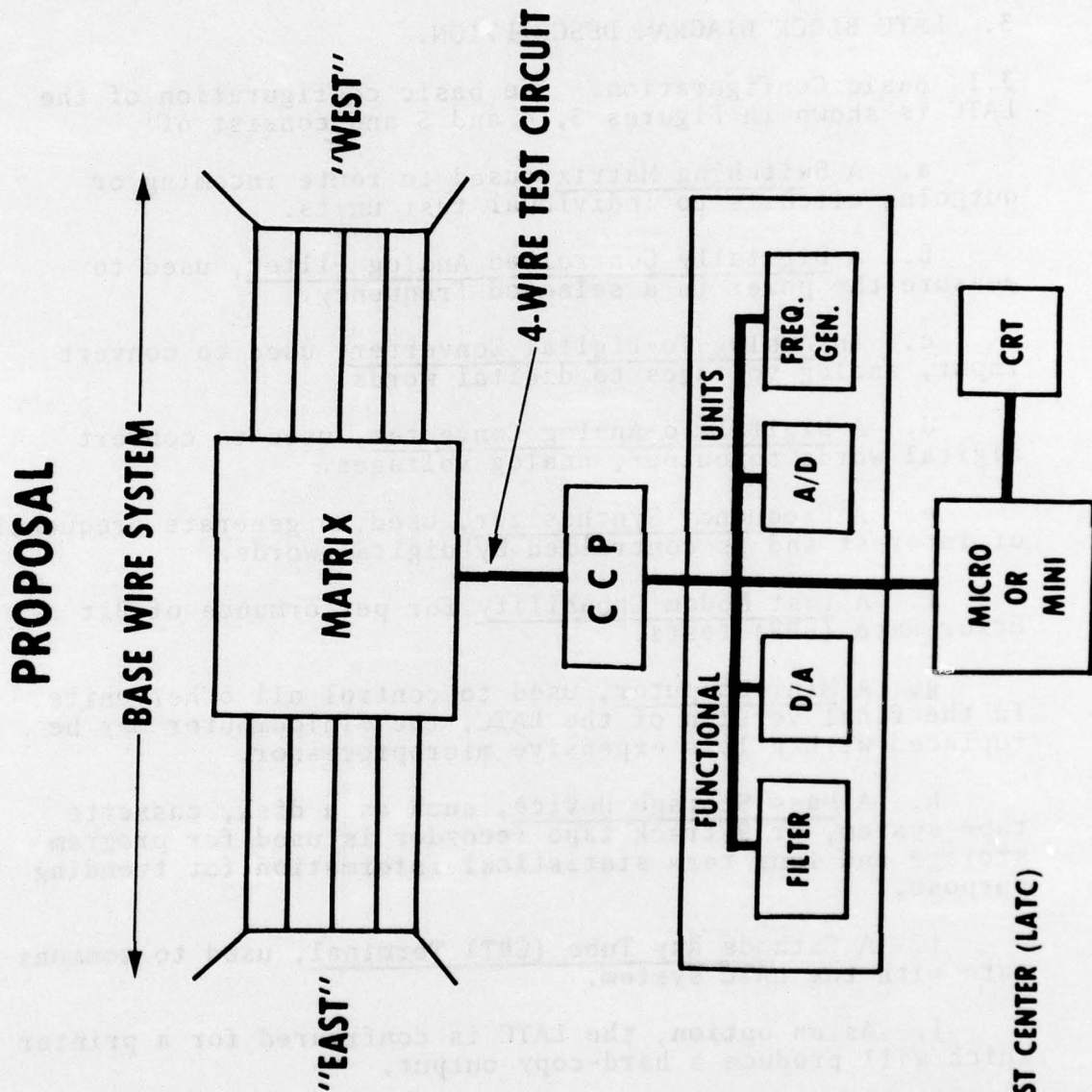
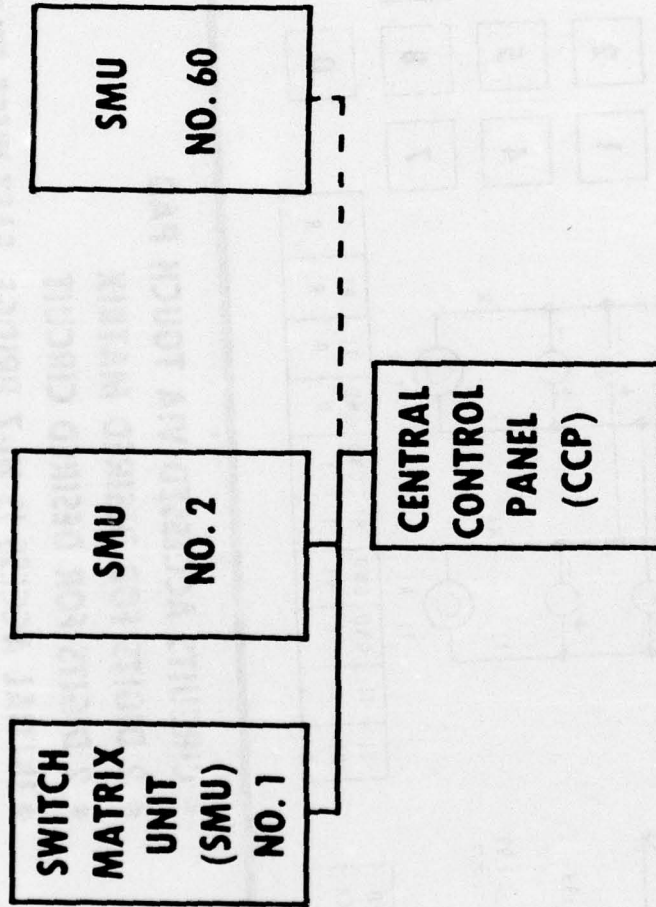

FIGURE 3
LOCAL AREA TEST CENTER (LATC)

MATRIX

FIGURE 4



- * **ALLOWS BRIDGING, TEST EAST, AND TEST WEST.**
- * **FREQUENCY RESPONSE WILL BE BETTER THAN CIRCUITS UNDER TEST (BASE WIRE).**
- * **78 4-WIRE CIRCUITS PER MODULE (SMU).**
- * **60 MATRIX MODULES PER CENTRAL CONTROL PANEL.**
- * **TOTAL CAPABILITY OF 4680 4-WIRE CIRCUITS PER CCP.**

CENTRAL CONTROL PANEL (CCP)

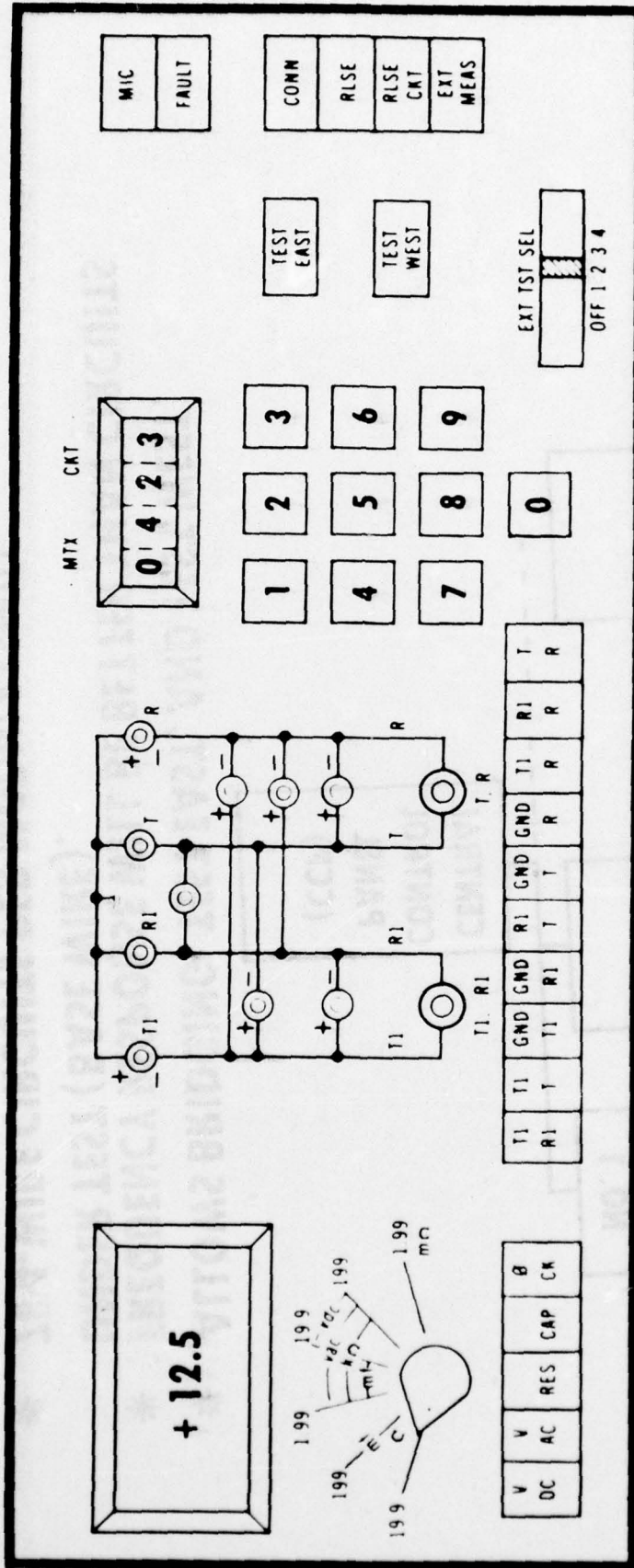

- * CIRCUITS ACCESSED VIA TOUCH PAD
- * 2 DIGITS FOR DESIRED MATRIX
- * 2 DIGITS FOR DESIRED CIRCUIT
- * INITIAL ACCESS IS HI-Z BRIDGE, EAST-WEST SELECTABLE
- * INTERNAL CAPABILITY FOR BASIC CABLE TESTS

FIGURE 5

LATC EXPANSION

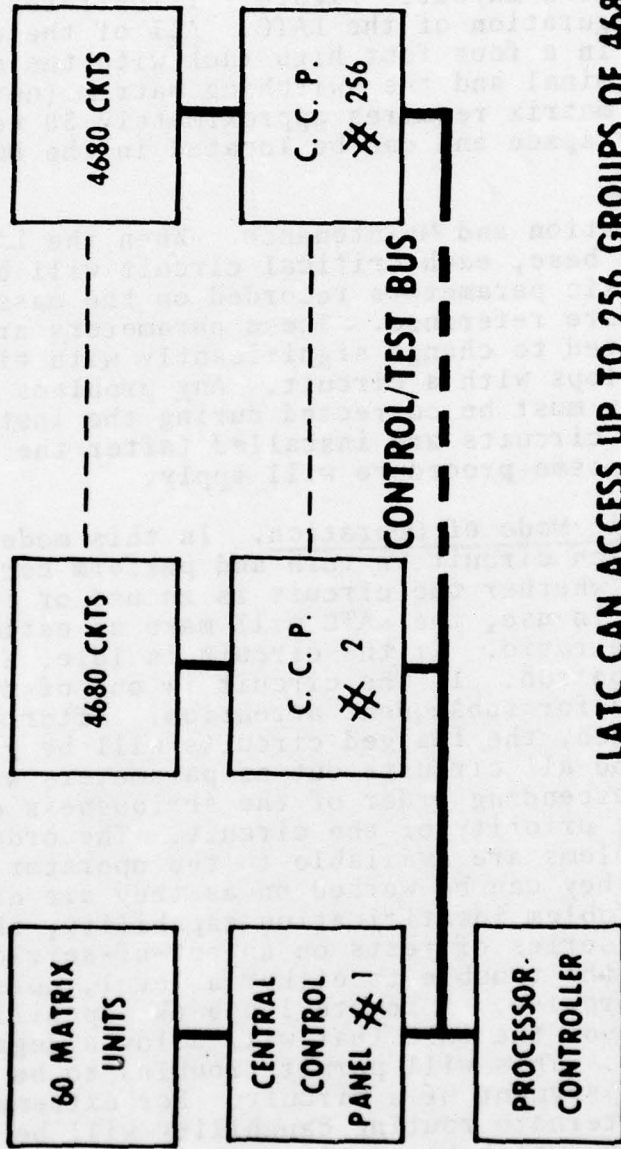

LATC CAN ACCESS UP TO 256 GROUPS OF 4680
4-WIRE CIRCUITS (1.19M)

FIGURE 6

steps of 4680 circuits. This expansion may be continued up to 256 groups of 4680 4-wire circuits under control of a single computer.

3.3 LATC Physical Layout. Figure 7 illustrates the physical configuration of the LATC. All of the electronics are contained in a four foot high rack with the exception of the CRT Terminal and the switching matrix (not shown). The switching matrix requires approximately 30 vertical inches of rack space and can be located in the DCO or other central point.

3.4 LATC Operation and Maintenance. When the LATC is installed at a base, each critical circuit will be checked out and its basic parameters recorded on the mass storage medium for future reference. These parameters are not normally expected to change significantly with time unless a problem develops with a circuit. Any problems discovered on the circuits must be corrected during the installation phase. As new circuits are installed (after the LATC is installed) the same procedure will apply.

3.4.1 Automatic Mode of Operation. In this mode the LATC will look at each circuit in turn and perform certain tests depending upon whether the circuit is in use or idle. If the circuit is in use, the LATC will make an estimate of the signal-to-noise ratio. If the circuit is idle, a frequency response will be run. If the circuit is out of tolerance it will be flagged for subsequent attention. After all circuits have been checked, the flagged circuits will be given a second check and all circuits out of parameters will be displayed in descending order of the seriousness of the problem and the priority of the circuit. The ordered list of current problems are available to the operator at all times so that they can be worked on as they are discovered. To provide a problem identification capability, the LATC will perform a series of tests on an out-of-service basis to narrow down the trouble to either a level, noise, or non-linearity problem. A remote loopback capability is another feature of the LATC that will allow a degree of fault isolation. This will permit troubles to be narrowed down to a small segment of a circuit. For extremely critical circuits, an alternate routing capability will be included to automatically switch to an alternate circuit in the event of trouble.

3.4.2 Semi-Automatic Mode of Operation. In the semi-automatic mode of operation, a maintenance technician can perform any of

FIGURE 7

PROPOSED LAYOUT

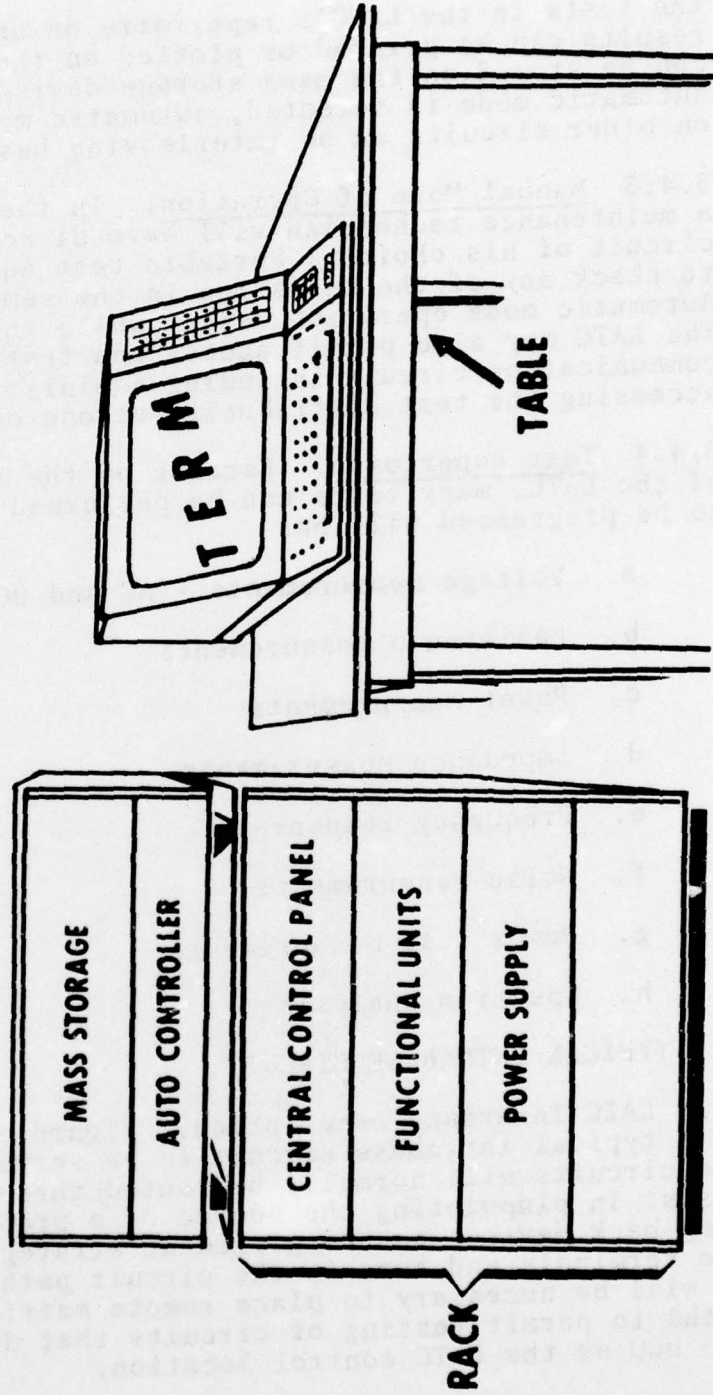

EP 4479

the tests in the LATC's repertoire on any circuit. Detailed results can be printed or plotted on the CRT terminal, or they can be stored on the mass storage device. Whenever the semi-automatic mode is selected, automatic mode operation continues on other circuits on an interleaving basis.

3.4.3 Manual Mode of Operation. In the manual mode of operation, a maintenance technician will have direct access to any circuit of his choice. Portable test equipment can be used to check any of the tests run in the semi-automatic mode. Automatic mode operation ceases while in the manual mode. The LATC may also permit access and testing of any base communication circuit including administrative circuits by accessing the test distribution at one of the matrix levels.

3.4.4 Test Repertoire. Because of the flexible structure of the LATC, many tests can be performed. The first tests to be programmed will be:

- a. Voltage measurements - AC and DC
- b. Resistance measurements
- c. Power measurements
- d. Impedance measurements
- e. Frequency response
- f. Noise measurements
- g. Power loss measurements
- h. Spectrum analysis

4. TYPICAL INTRABASE CIRCUIT

4.1 LATC Interface Description. Figure 8 is an illustration of a typical intrabase circuit to be served by the LATC. The circuits will normally be routed through the matrix. To assist in pinpointing the source of a problem automatically, loop-back devices can be placed at strategic points; i.e., the terminals and huts in the circuit path. In some situations it will be necessary to place remote matrices in the circuit paths to permit testing of circuits that do not pass through the DCO or the LATC control location.

TYPICAL INTRABASE CIRCUIT

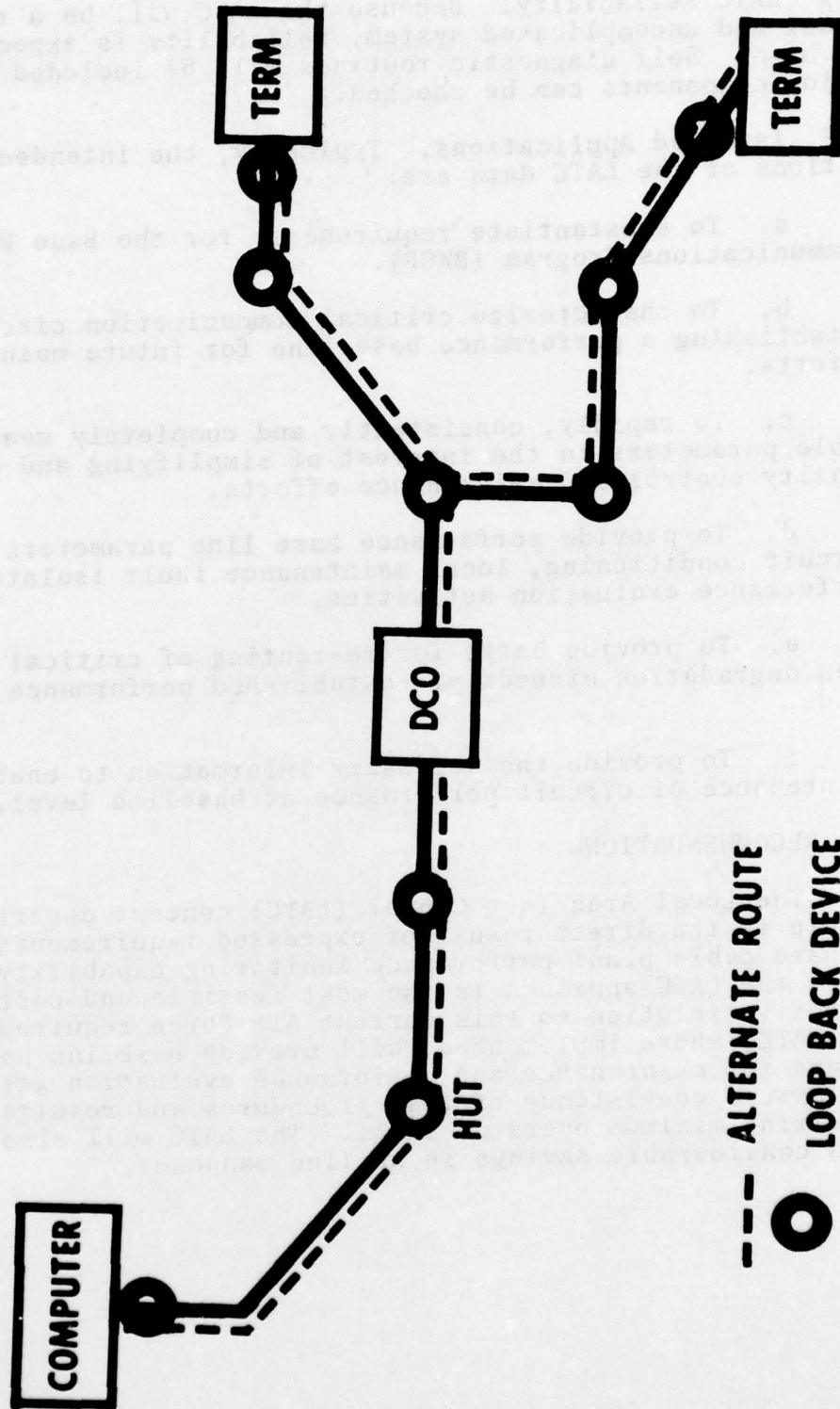

FIGURE 8

4.2 LATC Reliability. Because the LATC will be a relatively small and uncomplicated system, reliability is expected to be high. Self diagnostic routines will be included so that major components can be checked.

4.3 Intended Applications. Typically, the intended applications of the LATC data are:

a. To substantiate requirements for the Base Wire Communications Program (BWCP).

b. To characterize critical communication circuits, establishing a performance base line for future maintenance efforts.

c. To rapidly, consistently and completely measure cable parameters in the interest of simplifying and expediting quality control and maintenance efforts.

d. To provide performance base line parameters for circuit conditioning, local maintenance fault isolation and performance evaluation activities.

e. To provide basis for re-routing of critical circuits when degradation exceeds pre-established performance thresholds.

f. To provide the necessary information to enable the maintenance of circuit performance at baseline level.

5. RECOMMENDATIONS.

5.1 The Local Area Test Center (LATC) concept described herein is the direct result of expressed requirements for an on-base cable plant performance monitoring capability. Also, the LATC approach is the most feasible and cost effective solution to this current Air Force requirement. The LATC, where implemented, will provide baseline parameters for maintenance and performance evaluation activities and assure consistency of test procedures and results while requiring minimum operator skill. The LATC will also result in a considerable savings in skilled manpower.

6. REFERENCES:

Engineering Handbook for Intrabase Cable Test Facilities, CSC Report TR-74/3040, Dec 1974.

The Hewlett Packard Interface Bus - Current Perspectives HP Journal Vol 26, pg 2-4, Jan 1975 D.C. Loughry.

Standard Instrument Interface Simplifies System Design, Electronics, Vol 47, No 23, pg 95-105, Nov 1974.

Automated Tech Control, A Communication Monitoring System, ICC 73 Transactions. Dalrymple, J.H., et al.

Computer Assisted Tech Control in the Defense Communications System, ICC 72, Plotkin, I. P.

System/Equipment Analysis for Automated Technical Control (ATEC) Mar 1976. Subtask A Reports, Task 75-18, prepared by CSC.

Tech Control Modular Systems, Cooke Engineering Co., Dec 1975.

Digital Cable Systems Handbook, Vol II, Sep 1974, RADC TR-74-258.

DISTRIBUTION LIST:

USAF SAAS/TE-00A, KEESLER AFB, MISS. 39534	2
USAF SAAS/TC MTCB, SHEPPARD AFB, TX 76311	2
HQ AFCS/LG/OA/DO/XP/EP/CS	1
HQ AFCS/EPECRM	1
1842 EEG/EPECW	3
HQ NCA/EPE/EPZ	2
HQ SCA/EPE	2
HQ PCA/XME	2
1923 CG/LGMP, KELLY AFB, TX 78241	1
1964 CG/XRP	1
COMMANDER, USACC/CC-OPS-OX, FT. HUACHUCA, AR 85613	2
Defense Documentation Center, Alex., Va.	10