

AD-A032 590

ARMY ENGINEER WATERWAYS EXPERIMENT STATION VICKSBURG MISS F/G 8/13
EVALUATION OF SOIL MECHANICS LABORATORY EQUIPMENT: REPORT NO. 3--ETC(U)
APR 61 J E MITCHELL

UNCLASSIFIED

WES-MP-3-478-3

NL

1 OF 1
AD-A
032 590



END
DATE
FILMED
1-26-77
NTIS

U.S. DEPARTMENT OF COMMERCE
National Technical Information Service

AD-A032 590

EVALUATION OF SOIL MECHANICS LABORATORY EQUIPMENT
REPORT NO. 3. EVALUATION OF AVAILABLE LIQUID
LIMIT DEVICES

ARMY ENGINEER WATERWAYS EXPERIMENT STATION,
VICKSBURG, MISSISSIPPI

APRIL 1961

0

ADA032590

EVALUATION OF SOIL MECHANICS LABORATORY EQUIPMENT

EVALUATION OF AVAILABLE LIQUID LIMIT DEVICES

CWI ITEM NO. 516



MISCELLANEOUS PAPER NO. 3-478

Report 3

April 1961

DDC
RECEIVED
NOV 27 1976
REGISTERED
D

REPRODUCED BY
NATIONAL TECHNICAL
INFORMATION SERVICE
U. S. DEPARTMENT OF COMMERCE
SPRINGFIELD, VA. 22161

U. S. Army Engineer Waterways Experiment Station
CORPS OF ENGINEERS
Vicksburg, Mississippi

ARMY-MRC VICKSBURG, MISS.

DISTRIBUTION STATEMENT A
Approved for public release;
Distribution Unlimited

27

TA1
W34m
no. 3-478
Rept. no. 3
Cp. 2

Report and form J. E. ...
with ...

THE CONTENTS OF THIS REPORT ARE NOT TO BE
USED FOR ADVERTISING, PUBLICATION, OR
PROMOTIONAL PURPOSES

PREFACE

This investigation was conducted for the Office, Chief of Engineers, as directed in letter dated 5 February 1957, subject "New Civil Works Investigation Project." The project was designated "Evaluation of Soil Mechanics Laboratory Equipment (CW-516)."

This report is the third in a series on the evaluation of soil mechanics laboratory equipment. The work was performed by personnel of the Soils Test Section, U. S. Army Engineer Waterways Experiment Station, under the general supervision of Messrs. W. J. Turnbull and W. G. Shockley, Chief and Assistant Chief, respectively, Soils Division, and under the immediate supervision of Mr. J. E. Mitchell, Chief, Soils Test Section. This report was prepared by Mr. Mitchell.

Col. Edmund H. Lang, CE, was Director of the Waterways Experiment Station, and Mr. J. B. Tiffany was Technical Director during the course of this investigation.

CONTENTS

	<u>Page</u>
PREFACE	iii
PART I: INTRODUCTION	1
PART II: PHYSICAL MEASUREMENTS OF THE DEVICES	6
Base	6
Cup	8
Cam	9
Grooving Tools	14
PART III: PERFORMANCE OF THE DEVICES	16
Comparative Tests	16
Results of Comparative Tests	17
PART IV: CONCLUSIONS AND RECOMMENDATIONS	22

TABLES

Table

1 Sources of Supply and Prices for Liquid Limit Devices Tested	5
2 Size of Bases and Feet	7
3 Size and Weight of Cup	8
4 Grooving Tool Dimensions	14
5 Liquid Limit Results - Comparative Tests	17

FIGURES

Fig.

1 ASTM Liquid Limit Device	2
2 Harvard Liquid Limit Device	3
3 Liquid Limit Device - Details	4
4 Plots of Angle of Crank Rotation vs Rise of Cup, Devices 1 and 2	10

FIGURES (Continued)

	<u>Page</u>
5 Plots of Angle of Crank Rotation vs Rise of Cup, Devices 3 and 4	11
6 Plots of Angle of Crank Rotation vs Rise of Cup, Devices 5 and 6	12
7 Plots of Angle of Crank Rotation vs Rise of Cup, Devices 7 and 8	13
8 Device Number vs Liquid Limit Values and Hardness of Base . . .	18
9 Liquid Limit Values vs Rockwell "L" Hardness of Base	20
10 Liquid Limit Values vs Ball Rebound Hardness of Base	21

EVALUATION OF AVAILABLE LIQUID LIMIT DEVICES

CWI 516

PART I: INTRODUCTION

1. Because of their simplicity and ease of performance, the Atterberg limits tests have become a valuable and widely used aid in the rapid determination of soil properties. The development by Casagrande in 1932 of a mechanical device with which to perform the liquid limit test removed most of the element of personal error and greatly increased the accuracy of the test results. Drawings of this device were made by the Bureau of Public Roads in 1934 and with minor revisions have been used to the present time by that organization and also by the American Society for Testing Materials (see fig. 1). In 1949, because of increasing laxity on the part of various manufacturers, Casagrande had a new set of drawings made (figs. 2 and 3) which incorporated several revisions, the most significant one being the use of "Micarta" No. 221 to replace the hard rubber originally used for the base.

2. Because several of the division laboratories of the Corps of Engineers had raised questions concerning the accuracy of the liquid limit test and the equipment used to perform it, there was a need for a comparative evaluation from a mechanical and operational standpoint of the devices commercially available on the open market.

3. Inquiries were sent to 14 scientific equipment supply companies for the names of the manufacturers of the device and price quotations. The replies from the companies contacted showed that the devices came from seven manufacturers. The results of this canvass are shown in table 1. Orders were placed for eight devices, seven ASTM and one Harvard type. At the time of purchase only one manufacturer listed a Harvard-type device; since then one other manufacturer has started producing the Harvard-type (Micarta No. 221 base) device. To ensure fair procurement of representative samples of commercial production, no indication was given any of the suppliers that the devices were being purchased to determine conformance with specifications and for correlative testing. The prices quoted in table 1 include a standard ASTM grooving tool except as noted.

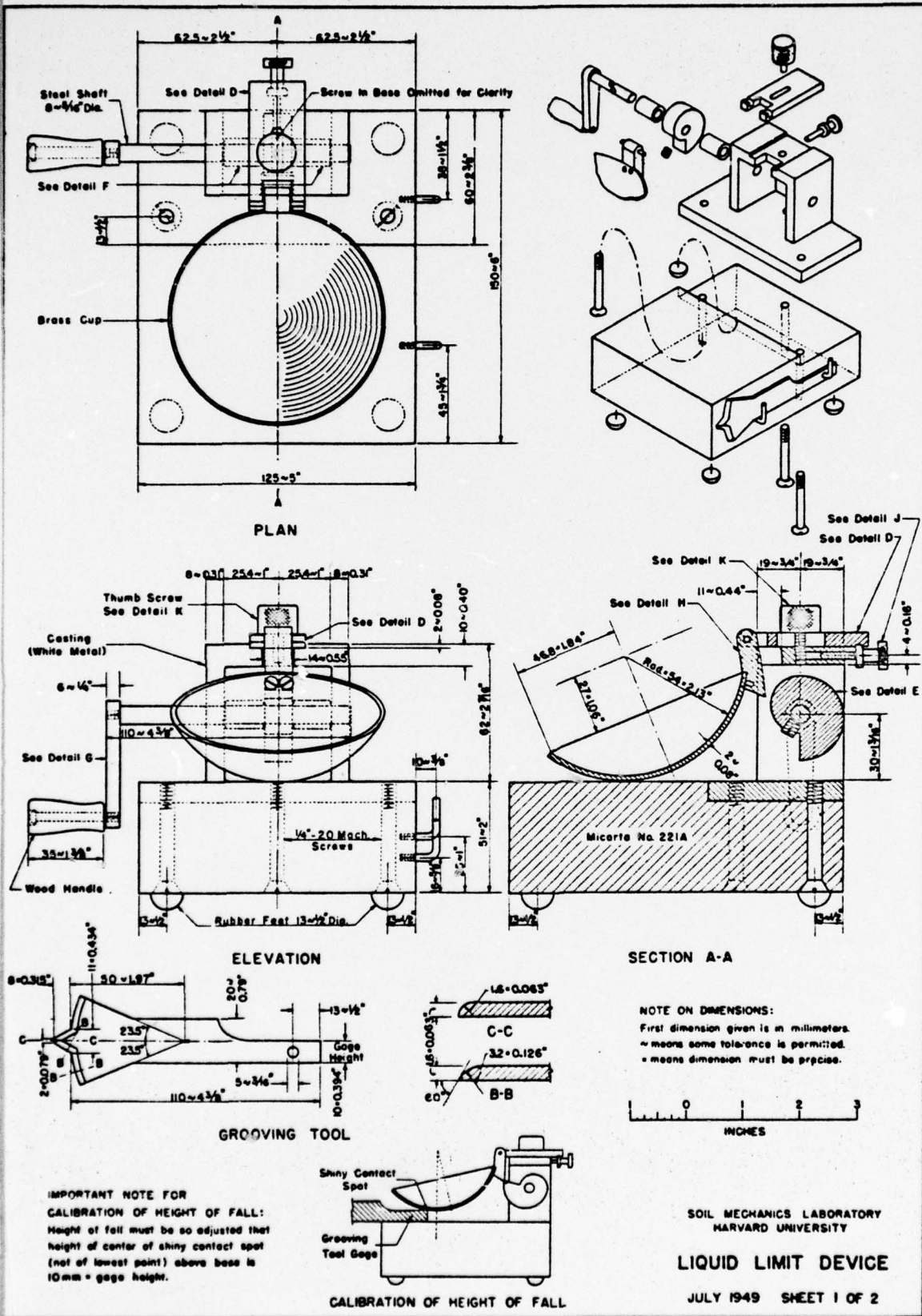

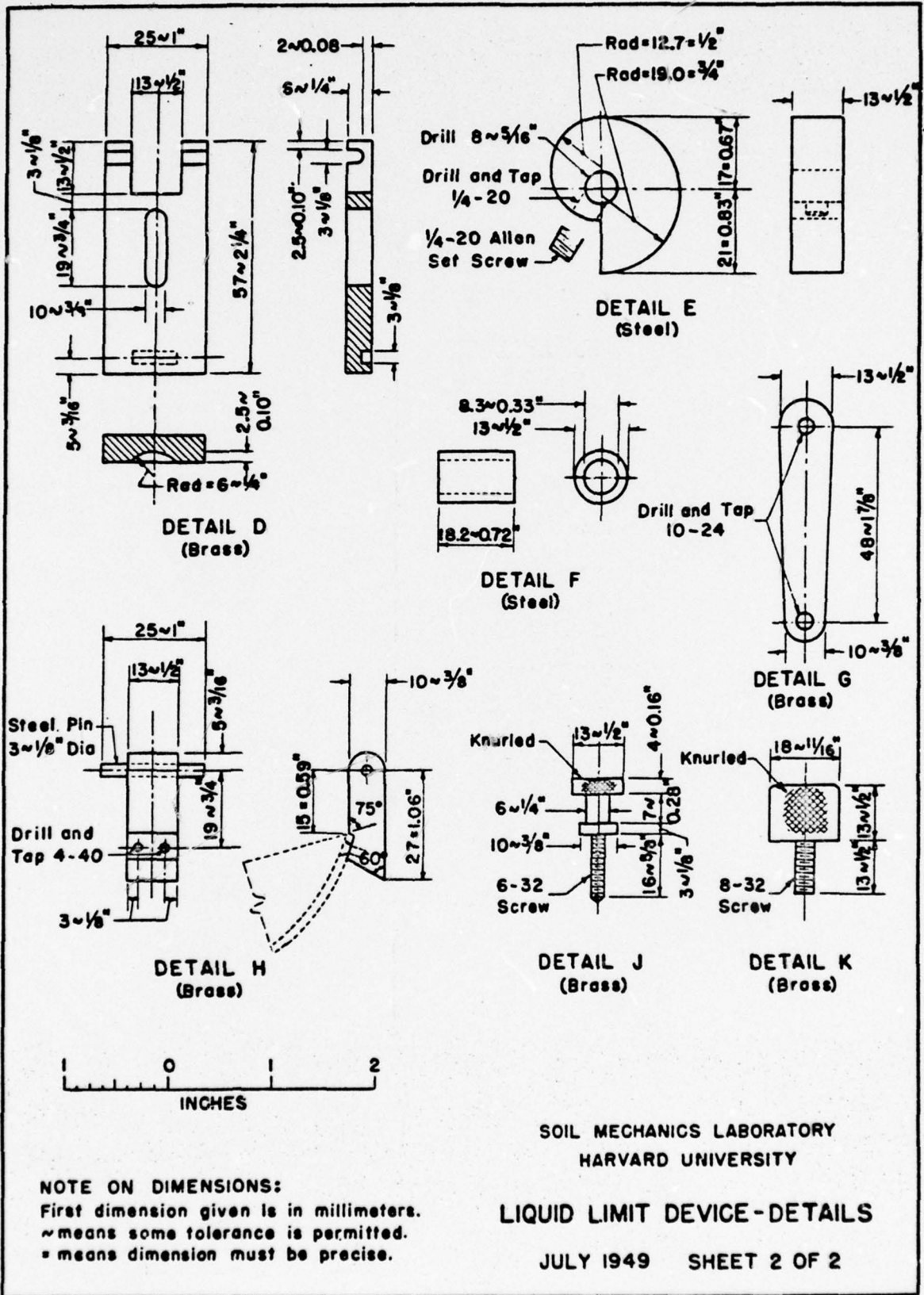

FIG. 3

4

Table 1

Sources of Supply and Prices for Liquid Limit Devices Tested

<u>atalog no.</u>	<u>Supplier</u>	<u>Manufacturer</u>	<u>Quoted Price May 1959</u>
34	Fisher Scientific Co.	Hogentogler	\$ 65.00
95	Precision Scientific Co.	Own	105.50
207	Soiltest Inc.	Own	45.00
207	Soiltest Inc.	Own	45.00
7045	Chemical Rubber Co.	Humbolt, L-3021	60.00
77	American Instrument Co.	Own	42.50*
3770	Harshaw Scientific Co.	Precision, 23895	97.50
	Harshaw Scientific Co.	Humbolt, 4230	60.00
230	Humbolt Manufacturing Co.	Own	55.00
411	Hogentogler Co.	Own	42.50
5	Chicago Appliance Co.	Humbolt, 4230	97.50
94	Central Scientific Co.	Humbolt	60.75
09	W. H. Curtin Co.	Humbolt	64.50
021	Technical Products Co.	Humbolt	57.50
4935	E. H. Sargent Co.	Humbolt	90.00
25	Stebbins Mfg. and Supply Co.	Own	48.00
2.111	Testlab	Own	39.00

Device only. Casagrande grooving tool \$4.75 extra.

Casagrande flat-type grooving tool was also purchased when available.

4. This report contains the physical measurements and comparative test results of the eight devices purchased.

PART II: PHYSICAL MEASUREMENTS OF THE DEVICES

Base

5. All of the bases of the liquid limit devices were hard rubber except device 4 (table 2), which was the Harvard type with a base of "Micarta" 221. Dimensions of the bases and feet are given in table 2. The width of the bases varied from 4.80 to 5.00 in., the length from 5.85 to 6.00 in., and the thickness from 2.00 to 2.05 in. These variations in size are not considered significant.

6. The hardness of the bases (table 2) was determined with a Rockwell hardness tester and also by measuring the height of rebound of a hardened steel ball dropped from a height of 10 in. The height of rebound was measured to the top of the ball with a cathetometer and the diameter of the ball was subtracted to give the true rebound height. The size of ball does not appear to be critical, as similar results were obtained with balls of 0.250, 0.312,* and 0.375 in. in diameter.

7. The Rockwell hardness tester used was not of the long-stroke (PL) type (which is the most desirable type for testing softer materials). The "L" scale was found to be the most satisfactory of the several scales tried. The ASTM D 785-51 Method A test was used, with the exception that the temperature was 77 F and the relative humidity 60% for conditioning and testing the bases. The base hardness values ranged from 78 for device 5 to 120 for device 1 on the Rockwell "L" scale. The Micarta base (device 4) had a hardness number of 111. Device 8 had a base hardness number of 112, essentially the same as the Micarta base. The bases of devices 5 and 6 were appreciably harder (78 and 80, respectively) than those of the other devices. This appears to sustain the contention of some laboratories that the hard rubber now manufactured is not a material of constant hardness. The effect of the variations in hardness of the bases is discussed in Part III, "Results of Comparative Tests," of this report.

8. All of the bases were mounted on four rubber feet except device 1, which had metal-button feet covered with wool felt. However, there was

* Original steel ball used in tests for Dr. Casagrande in 1958.

Size of Bases and Feet

Device No.	Thick-			Base		Feet		Hardness Shore Durometer	
	Length in.	Width in.	Thickness in.	Rockwell "L" Rebound*	Finish of Top	Size in.	Material		
1	6.00	4.95	2.05	120	7.6	Smooth	0.75 diameter	Metal, felt-covered	60
2	6.00	4.80	2.05	102	8.8	Polished	0.90 diameter, hemispherical	Soft rubber	75
3	5.95	4.93	2.00	102	8.8	Polished	0.50 diameter, hemispherical	Hard rubber	100
4	6.00	4.98	2.02	111	7.9	Polished	0.40 diameter, hemispherical	Rubber	85
5	5.88	4.90	2.00	78	8.1	Polished	0.60 diameter, hemispherical	Rubber	85
6	5.92	4.94	2.00	80	7.1	Fitted	0.50 diameter, cylindrical	Rubber	85
7	5.85	4.91	2.03	98	8.3	Smooth	0.50 diameter, hemispherical	Rubber	85
8	6.00	5.00	2.00	112	8.2	Polished	0.60 diameter, cylindrical	Soft rubber	72
ASTM Standard	5.90	4.92	2.00	---	---	---	3/8 (0.375) diameter, hemispherical	Rubber	--
Harvard Standard	6.00	5.00	2.00	---	---	---	1/2 (0.500) diameter, hemispherical	Rubber	--

* Inches from 10-in. drop.

considerable variation in hardness of the feet. The Shore durometer hardness test gave readings from 60 to 100, but reliable results were difficult to obtain because of the sharp curvature of some of the feet.

Cup

9. The essential dimensions together with the weights of the cups are given in table 3. The dimensions of all cups were in close agreement. The chief factor causing the variations in weight between the cups is the difference in size and shape of the cam followers. Device 2 had an extra-wide follower (3/4 in.) compared to an average width of 1/2 in. for the other devices, which accounts for the high weight of the cup. Since the variation in weight of the cups is mostly due to the variation in size of the follower, which in turn is located very close to the point of

Table 3
Size and Weight of Cup

Device No.	Dimensions				Thickness		Weight of Cup g	Fit of Pin Holding Cup
	a in.	b in.	c in.	d in.	Edge in.	Bottom in.		
1	2.15	1.09	0.565	2.48	0.075	0.075	177	Good
2	2.13	1.06	0.573	2.36	0.082	0.075	218	Tight
3	2.14	1.10	0.612	2.40	0.074	0.074	169	--
4	2.14	1.12	0.640	2.52	0.062	0.075	163	--
5	2.17	1.10	0.583	2.34	0.082	0.076	194	Tight
6	2.16	1.10	0.508	2.34	0.082	0.077	196	Good
7	2.14	1.08	0.618	2.27	0.077	0.076	191	Tight
8	2.12	1.06	0.555	2.49	0.070	0.080	179	Good
ASTM Standard		1.06	---	2.34	0.079	0.079	---	
Harvard Standard	2.13	1.06	---	2.44	0.080	0.080	---	

Note:

- a. Radius of curvature of inside of cup.
- b. Perpendicular distance from center of curvature of cup to plane of top edge of cup.
- c. Distance between cup pin and top edge of cup.
- d. Distance of cup pin above base.

ension, it is not believed the differences in weight of cups would affect the test results significantly. Therefore, no comparative tests were made to determine the effect of cup weight on liquid limit values. If the cups were made of yellow brass except that of device 2 which was made of red brass.

10. The cups were attached by a pin through a hole in the adjustment plate and cam follower, except for devices 3 and 4 which were held as shown in Figs. 2 and 3 with a keeper on top of the slot to hold the pin in place. The position of the pin holding the cup is important to those who prefer to remove the cup while forming the groove in the soil as advocated by Casagrande. The pins on devices 2, 5, and 7 were too tight to permit removal of the cup from the device and were hand-filed to the proper clearance before testing was begun. The handle on the pin in device 5 was small, which made it somewhat inconvenient to remove. The cam follower on device 6 was wedged too tightly in the slot of the adjustment plate and required adjustment to make it drop freely.

Cam

11. The shape of the cam in the ASTM design of the device is based on a spiral. Dr. Casagrande changed the cam design of the Harvard device so that it is composed of the arcs of two circles, which according to him is much more easily manufactured.* This design ensures that the height of the cup is held constant at 1.0 cm, as the crank is turned, for a short interval just prior to drop of the cup by the cam. This eliminates the possibility of the cup continuing to rise in height after the instant of release while the crank is being turned. Plots of angle of crank rotation in degrees versus the rise of the impact point of the cup in centimeters are shown in Figs. 4 through 7. These plots show the relative smoothness of the cup and the arc through which the crank must be turned to drop the cup to full height before its release. Neither the ASTM nor the Harvard device specifies a definite angle of rotation of the crank. The Harvard** require 270-degree angle of crank rotation in their device. The

Casagrande, Geotechnique, vol VIII, No. 2 (June 1958), p 86.
E. J. Norman, Geotechnique, vol VIII, No. 2 (June 1958), p 83.

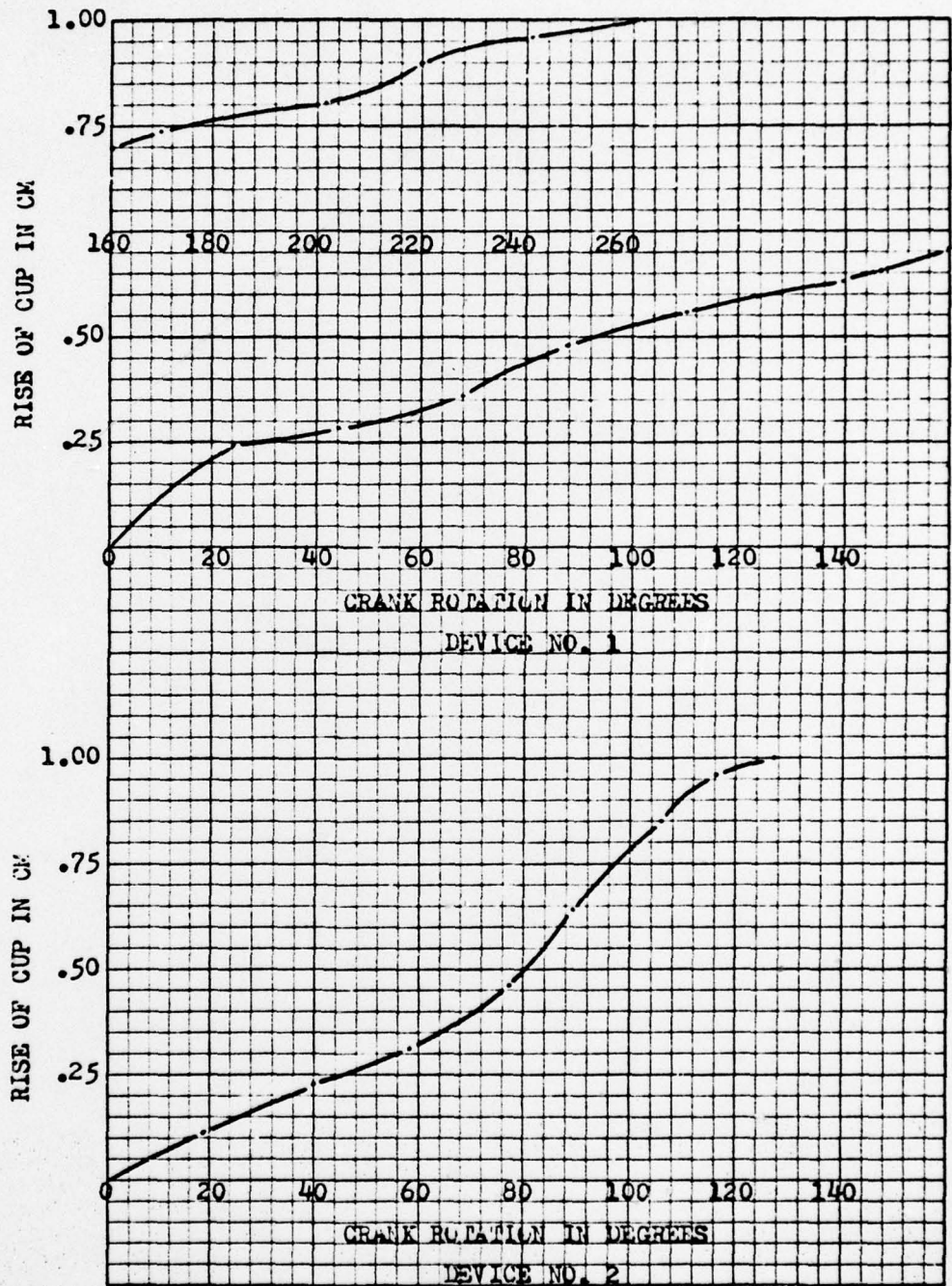

PLOTS OF ANGLE OF CRANK ROTATION VS RISE OF CUP, DEVICES 1 AND 2

FIG. 4

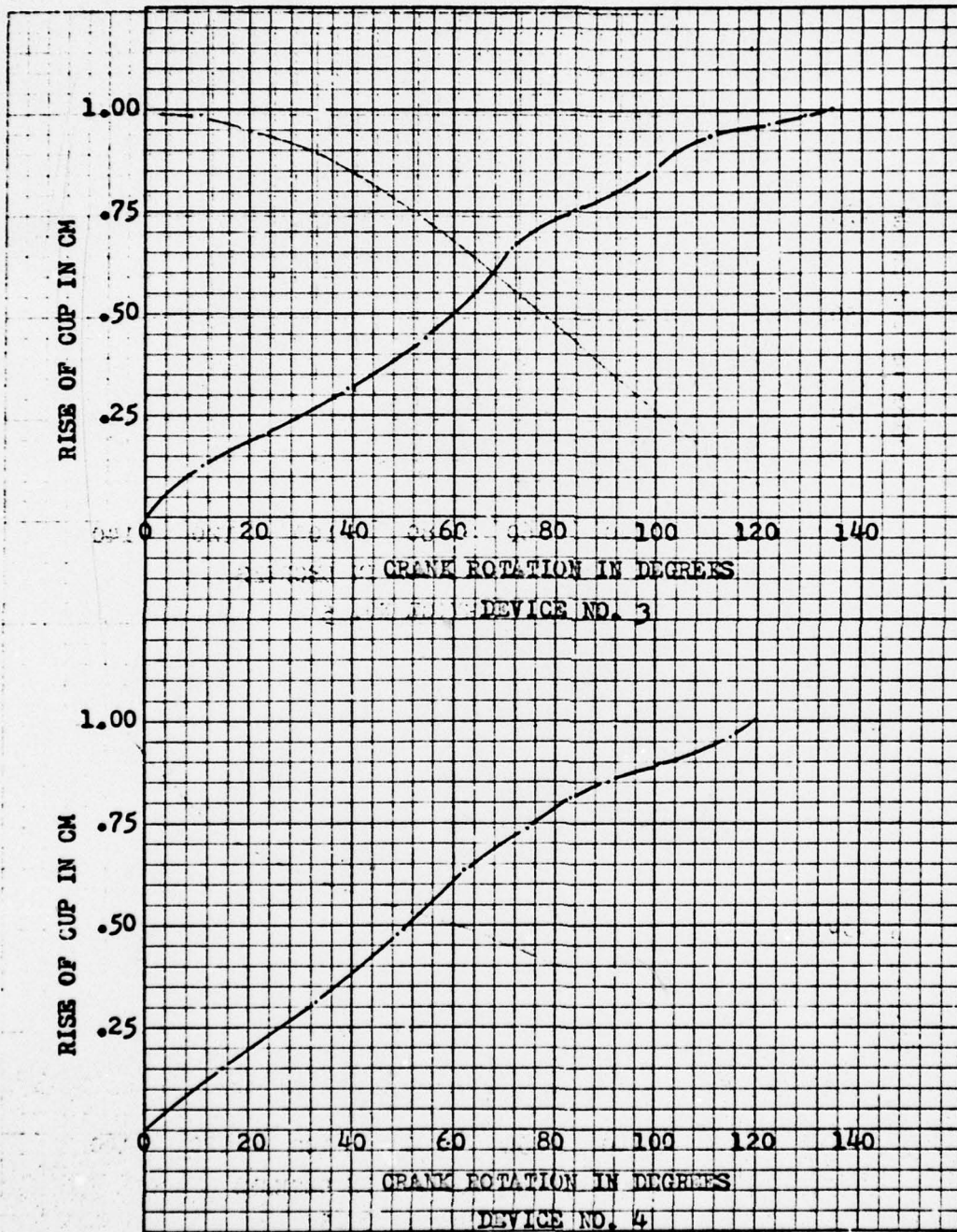

PLOTS OF ANGLE OF CRANK ROTATION VS RISE OF CUP, DEVICES 3 AND 4

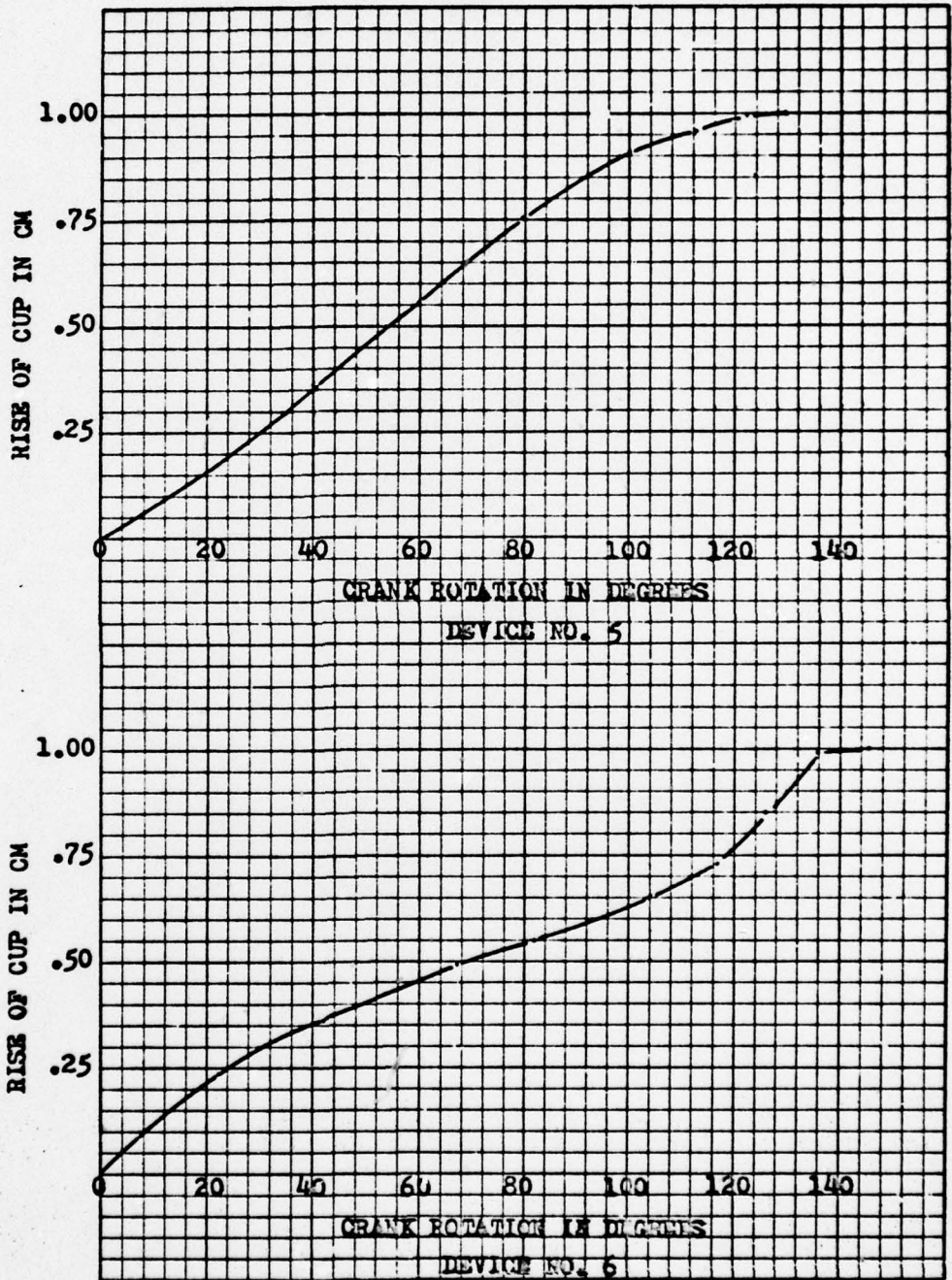

PLOTS OF ANGLE OF CRANK ROTATION VS RISE OF CUP, DEVICES 5 AND 6

FIG. 6

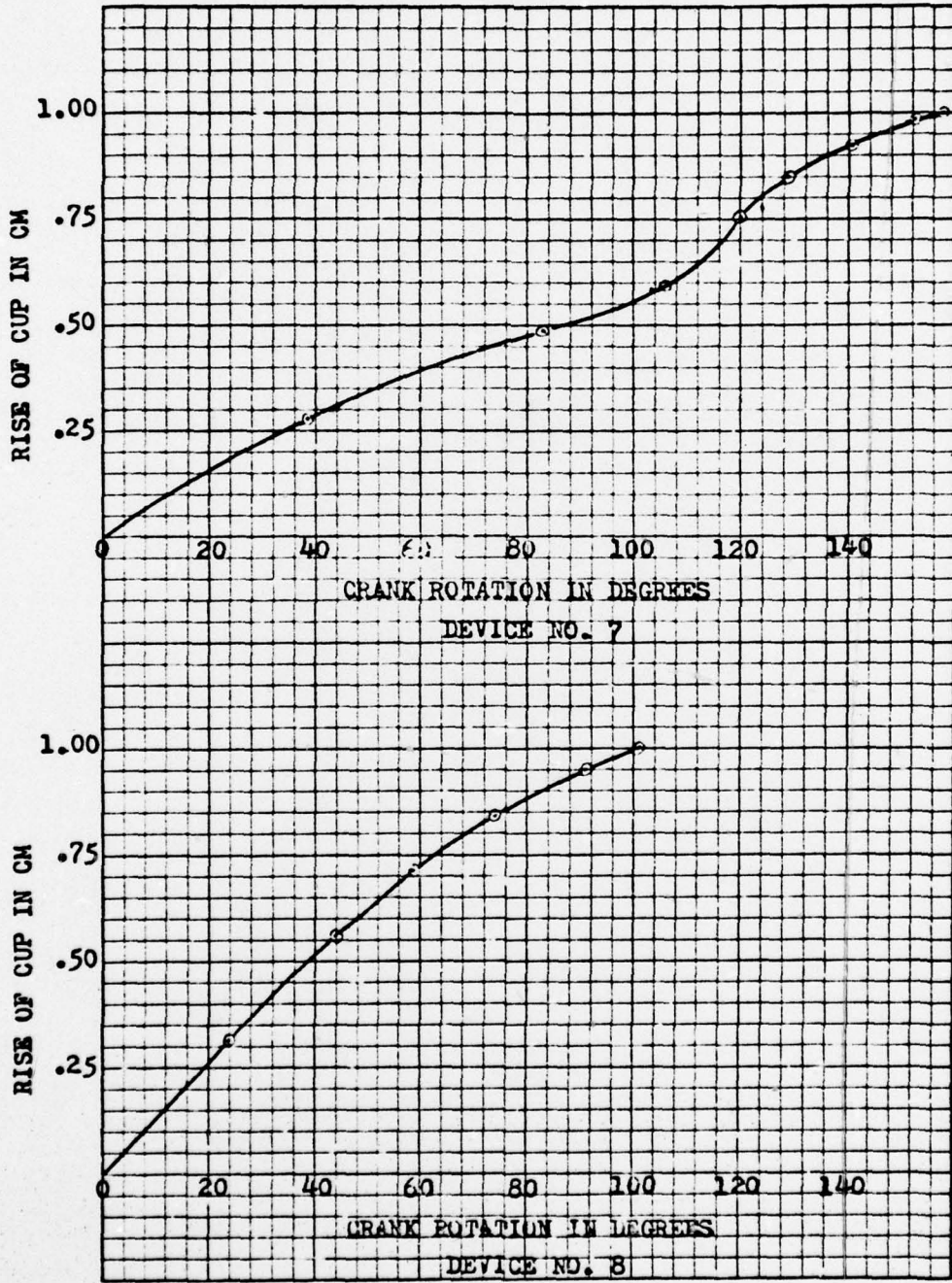

PLOTS OF ANGLE OF CRANK ROTATION VS RISE OF CUP, DEVICES 7 AND 8

only device that approached this figure was device 1 with an angle of 263 degrees. Most of the devices tested had angles of rotation between 120 and 140 degrees.

12. The tendency to overshoot, mentioned above, is minimized when the height of drop of cup is checked with the crank rotated at the specified speed. Most instructions for calibration of height of drop of the cup specify that this height be checked by rotating the crank at 2 turns per second with the height gage under the cup. Only a slight click should be heard if the adjustment is correct. Figs. 6 and 7 show that the cups of devices 5, 6, and 7 reach the 1-cm rise and remain constant before they are dropped; devices 2 and 3 approach this ideal condition. Devices 1, 4, and 8 might possibly overshoot and give a drop greater than 1.0 cm if the standard speed of rotation of the crank (2 turns per second) is exceeded.

Grooving Tools

13. The grooving tools, although not part of the device, are usually purchased with it, and drawings of the device also show the grooving tool. When available, a grooving tool of each type (ASTM and Casagrande) was purchased with each device. The measurements shown in table 4 were made with

Table 4

Grooving Tool Dimensions

Device No.	ASTM				Casagrande			
	Depth mm	Width mm		Gauge cm	Depth mm	Width mm		Gauge cm
		Top	Bottom			Top	Bottom	
		mm	mm			mm	mm	
1	10.00	13.59	2.0	1.00	8.25	10.69	1.75	1.00
2	9.98	13.51	2.0	1.00	8.50	10.95	2.00	1.00
3	9.98	13.46	2.2	1.00	--	---	--	---
4	--	---	---	--	8.00	10.95	2.00	1.00
5	10.10	13.41	1.8	1.00	8.00	11.20	2.25	1.00
6	9.98	13.39	1.8	1.00	8.50	11.20	1.60*	0.993
7	9.98	13.31	2.0	1.00	7.50	9.19	2.25	0.957
8	10.00	13.39	2.25	1.00	--	---	--	---
Standard	10.00	13.46	1.98	1.00	8.00	11.00	2.00	1.00

* One corner rounded; difficult to measure true width.

reticle in a 10X microscope. The height-of-drop gauges on the ends of the grooving tools were measured with a micrometer caliper. Several of the tools varied from the specified size in at least one dimension; 50 per cent both the ASTM and Casagrande grooving tools were -0.4 to $+0.25$ mm off the standard width at the bottom of the tool. Permissible variation from standard width is ± 0.05 mm.* The ASTM grooving tools supplied with devices 1, 2, and 7 and the Casagrande tools supplied with devices 2 and 4 would meet this standard.

14. Because of the thin edges, the flat type of tool is subject to rapid wear, especially in soils of low plasticity. Several of the manufacturers hardened the edges of the tool to increase resistance to abrasion, but it was impossible to measure the degree of hardness because of the thinness of the edges. Hardening of the edges unquestionably increases the resistance to abrasion and prolongs the useful life of the tool.

A. Casagrande, "Research on the Atterberg limits of soils," Public Roads, vol 13, No. 8 (October 1932), p 128.

PART III: PERFORMANCE OF THE DEVICES

Comparative Tests

15. Many variables influence the test results obtained with the liquid limit device. Comparative tests were made to measure the cumulative over-all effects of these variables, using two different soils (a fat clay and a lean clay) with each of the eight devices. The grooving tools supplied with each device were used for the tests. The same operator was used for each series to eliminate this variable from the test results.

16. Each of the two soils used in these tests was thoroughly mixed with sufficient water to make the sample considerably wetter than the plastic limit. Each sample then was allowed to cure in a tightly closed container for five days or more before testing was begun. A sufficient quantity of material to make eight limit determinations then was removed from the cured sample. This was divided into three equal parts and each part was mixed with the necessary water to give three points on the liquid limit flow line. This procedure to a large extent eliminated from the test results the effect of variations in mixing and time of hydration.

17. The devices were carefully adjusted to secure the specified height of drop of the cup. The adjustment was considered satisfactory when, with the gauge held in the proper position, a slight click was produced by turning the crank at a rate of two turns per second. This is the standard method for adjusting the height of drop and when used minimizes to some extent the effect of improper shaping of the cam, especially at the point of release.

18. Several minor mechanical defects in fit of parts of the devices were observed during the tests. Devices 2, 5, and 7 had too tight a fit of the pin on the cam follower, which made assembly and detaching difficult if not actually slowing the fall of the cup. In device 7 the fit of the cam follower in the slot was too tight as received; this was corrected by hand-filing so as to secure a free fit. Devices 1, 6, 7, and 8 had free-turning wooden crank handles as specified in the drawings; devices 2, 3, and 4 had metal crank handles which did not turn. These metal handles were considered to be slightly less desirable from the standpoint of convenience.

of operation. Device 5 had a metal handle which turned, but because of its small size it was not as easily operated as the wooden-handle cranks.

Results of Comparative Tests

19. Results of comparative tests made with the devices are given in table 5 and plotted graphically in fig. 6. The variation in liquid limit

Table 5
Liquid Limit Results - Comparative Tests

Device No.	Lean Clay (CL)		Fat Clay (CH)	
	Casagrande Tool from Mfr	ASTM Tool from Mfr	Casagrande Tool from Mfr	ASTM Tool from Mfr
1	45.3	45.4	64.0	63.8
2	44.2	43.9	63.1	62.2
3	44.2*	43.3	63.4*	62.6
4	45.2	44.5**	66.0	65.7**
5	44.5	43.0	63.6	61.2
6	43.8	43.8	60.3	60.0
7	45.5	43.2	63.7	63.3
8	44.5†	44.5	63.3†	63.4

* No Casagrande tool was supplied for device 3. The tool with device 4 was used for these tests.

** No ASTM tool was supplied for device 4. The tool with device 3 was used for these tests.

† No Casagrande tool was supplied for device 8. The tool with device 4 was used for these tests.

for the lean clay (CL) was 1.7 in the Casagrande grooving tool series and 2.4 in the ASTM tool series. For the fat clay (CH) the range was 5.7 in the Casagrande tool series and 5.7 in the ASTM tool series. The range of liquid limit values obtained with the devices would not be too serious if the test results were used for classification purposes. The variations could be significant if the liquid limit values were to be used for a specific purpose which required greater accuracy, or the results given by two or more devices were to be compared.

20. The hardness of the base as measured on the Rockwell "L" scale and as indicated by the ball-rebound test is plotted in fig. 8 for each

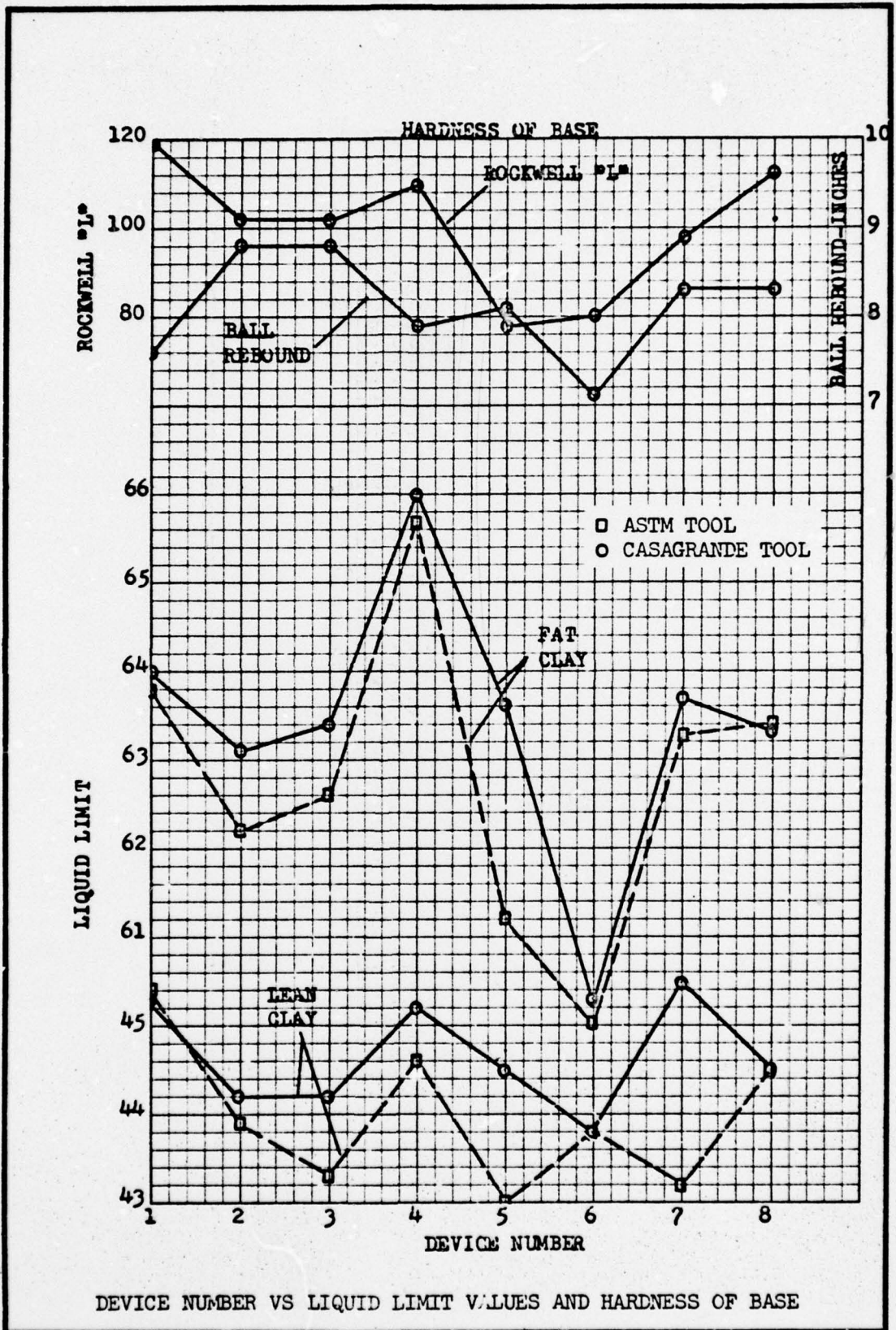

FIG. 8

of the device. Fig. 9 is a plot of base hardness measured on the Rockwell "L" scale versus liquid limit as determined by each of the two types of grooving tools. Fig. 10 is a plot of base hardness as measured by the ball-rebound test versus liquid limit as determined by the two types of grooving tools. Figs. 9 and 10 show essentially the same trends, which would appear to indicate that either method of determining hardness would be acceptable. When the hardness of the bases determined by the two methods is compared, there is reasonable agreement for all of the devices except Nos. 5 and 6. These two bases had Rockwell "I" hardness numbers of 78 and 80, which are the lowest values obtained in the devices tested; but the hardness numbers of these bases as measured by the ball-rebound test were 8.1 and 7.1 in., which is in the soft range. No explanation could be made for this anomaly; both tests were repeated several times and the hardness values checked each time. There appears to be a correlation between the hardness of the base as measured by either of the two methods and the corresponding liquid limit value. The devices with softer bases (1, 4, and 7) gave higher relative liquid limits. Devices 5 and 6 had considerably harder bases than the other devices (figs. 8, 9, and 10) and gave lower liquid limit values.

21. The results from the Micarta base of device 4 agreed with the results from devices with hard rubber bases of comparable hardness. It appears from the limited testing done that a Rockwell "L" hardness number of 95 to 115 of the base would be satisfactory when liquid limits are desired to within ± 1 for a lean clay and ± 2 for a fat clay.

22. This statement assumes that hardness of the base of the device is the only variable influencing the results, which is not necessarily true as other variables undoubtedly are present. However, it is believed that sufficient evidence is presented to show that the hardness of the base is a significant variable affecting the liquid limit test results.

23. The Casagrande grooving tool in general gave slightly higher liquid limits than the ASTM tool (table 5 and fig. 9). This fact has been further confirmed by other investigators.

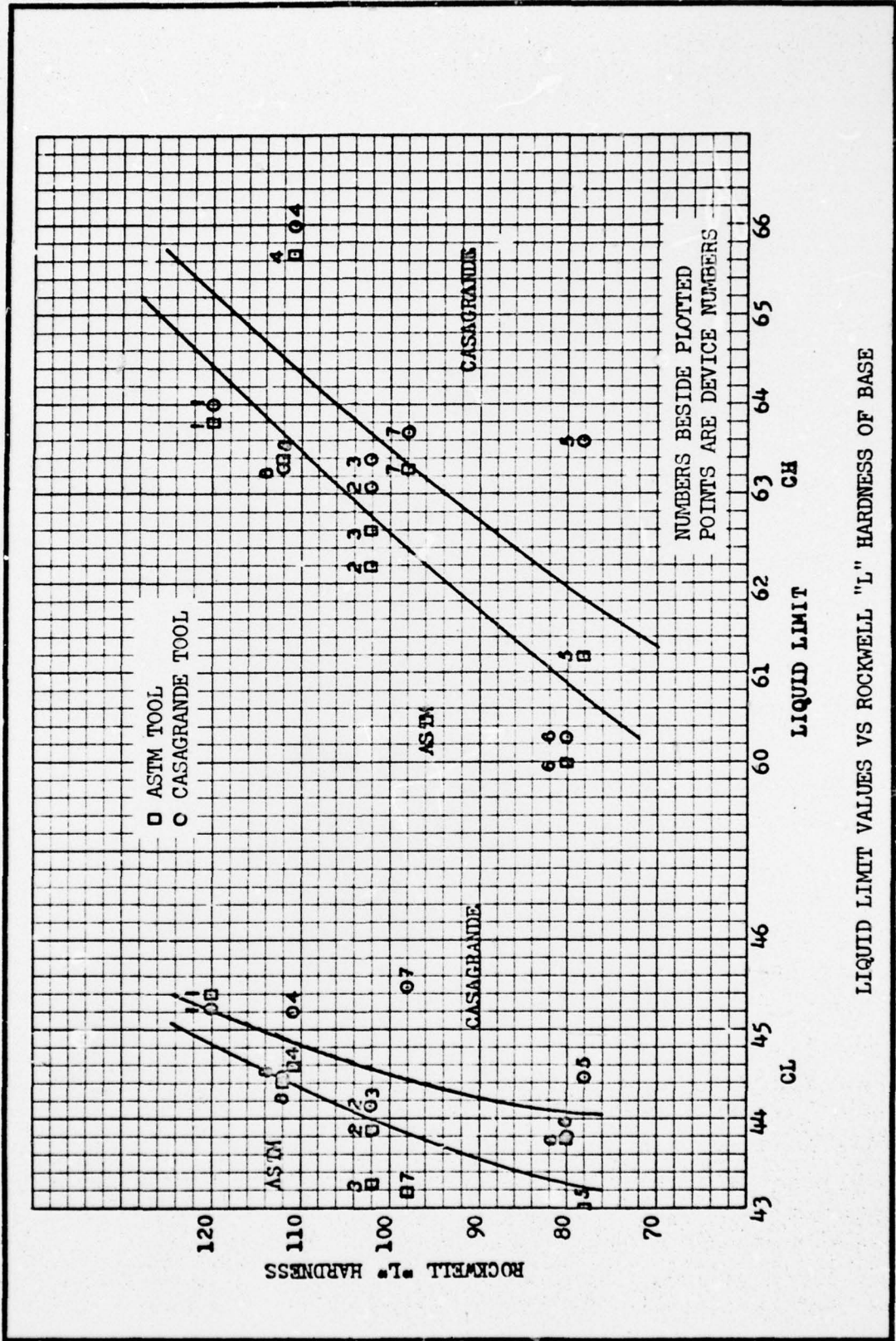
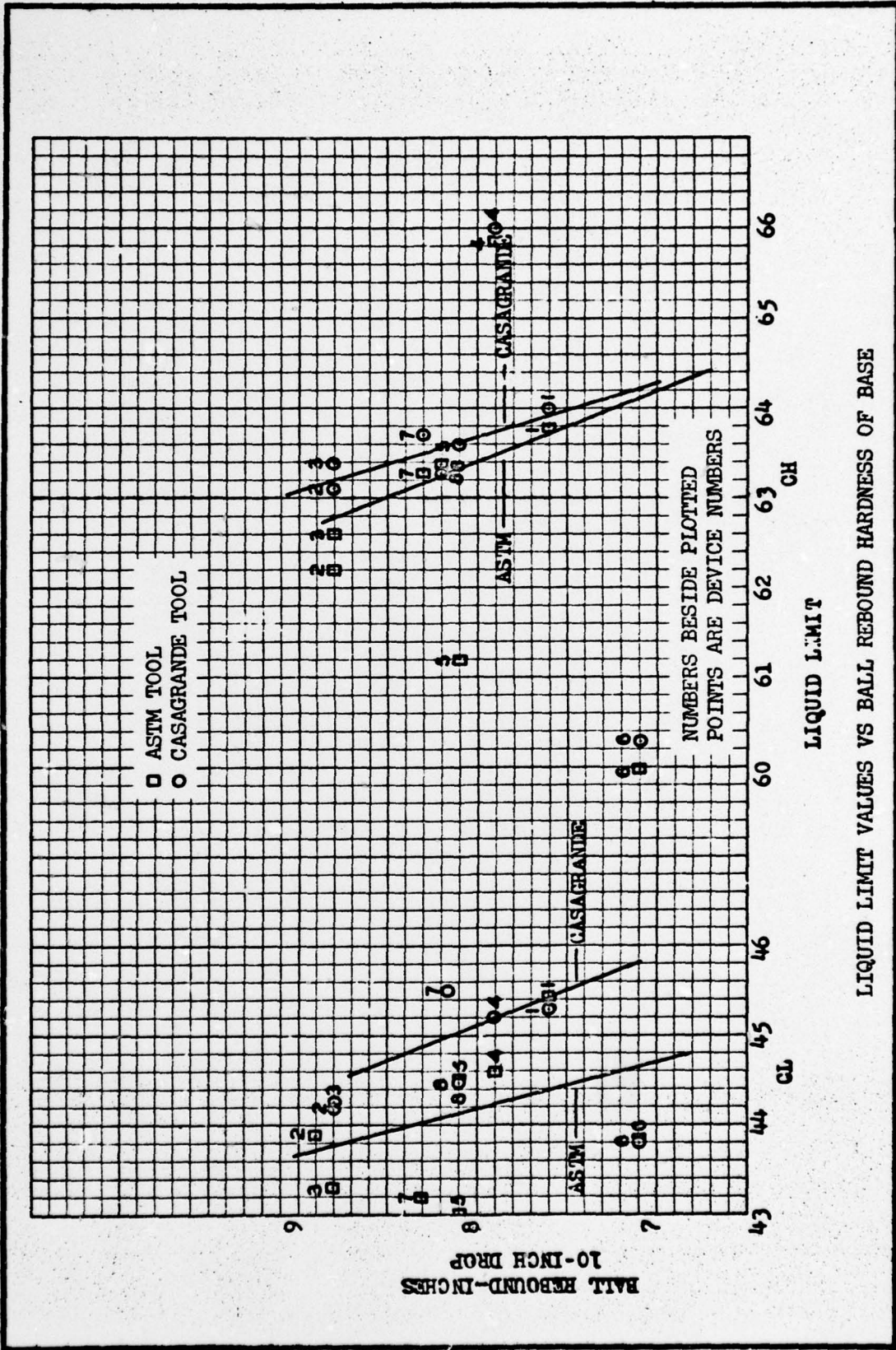

FIG. 9

LIQUID LIMIT VALUES VS ROCKWELL "L" HARDNESS OF BASE



PART IV: CONCLUSIONS AND RECOMMENDATIONS

24. On the basis of the results of the physical measurements and comparative tests of the eight devices purchased, it is believed that the following conclusions are warranted:

- a. The purchaser of a commercially produced liquid limit device can expect to make some minor adjustments in fit of parts, etc., to ensure a smooth-working device.
- b. The hard-rubber base material of the devices varies considerably in hardness and the hardness of the base affects the liquid limit values.
- c. The price of a device is no indication of its quality. The lowest-priced devices gave results comparable to the results obtained with the highest-priced devices.
- d. Grooving tools vary considerably from the standard dimensions.
- e. Use of the Casagrande grooving tool results in slightly higher liquid limits than does the ASTM tool. (Other investigators have reached this same conclusion.)

25. It is recommended that:

- a. The tolerances in dimensions, etc., as given in fig. 2 of the liquid and plastic limit procedures, Corps of Engineers, Civil Works, now being published, be adhered to in purchasing new devices.
- b. All grooving tools be checked for conformance to standard size before use.