

AD-A032 663

CALIFORNIA STATE UNIV LOS ANGELES

F/6 5/9

PEACE-TIME TASK ANALYSIS AND ITS RELATION TO WAR-TIME CONDITION--ETC(U)

APR 76 P J HANSON, C H STONE

N00014-74-A-0436-001

UNCLASSIFIED

TR-12

NL

1 OF 2  
AD  
A032663



AD A032663

(12)

# PEACE-TIME TASK ANALYSIS AND ITS RELATION TO WAR-TIME CONDITIONS

Phillip J. Hanson and C. Harold Stone

Technical Report No. 12

A Research Project Supported By  
Commandant of the Marine Corps (Code RD)  
And Monitored By  
Personnel and Training Research Programs  
Psychological Sciences Division  
Office of Naval Research  
Contract No. N00014-74-A-0436-0001  
NR 151-370

DDC  
NOV 30 1976

Approved for public release; distribution unlimited.  
Reproduction in whole or in part is permitted for  
any purpose of the United States Government.

California State University, Los Angeles

April, 1976

## RESEARCH STAFF

### PRINCIPAL INVESTIGATOR

C. Harold Stone, Ph.D., Graduate School Lecturer and Director,  
Ventura Counseling Center

### SENIOR RESEARCH ASSOCIATE

Dale Yoder, Ph.D., Emeritus Professor, Graduate School of Business,  
Stanford University; Emeritus Professor, School of Business  
Administration, California State University, Long Beach

### FACULTY

John M. Humphill, Jr., D.B.A., Associate Professor and Director,  
Bureau of Business and Economic Research

Donald G. Malachuk, M.S., Dean, School of Business and Economics  
and Professor of Management

Paul V. Washburn, Ph.D., Assistant Professor of Management

### CONSULTANTS

Phillip J. Hanson, B.S., Director, Weiss Center for Urban Research,  
Weiss State University

Arthur H. Kariloff, MBA, Lecturer, Graduate School of Management,  
University of California, Los Angeles

### RESEARCH ASSOCIATES

William T. Farrell, Ph.D. Candidate, UCLA

Peggy A. Judd, MBA

Akemi Kishi, B.A., MBA Candidate, CSULA



**UNCLASSIFIED**

SECURITY CLASSIFICATION OF THIS PAGE(When Data Entered)

Field War Games, Table Top War Games, Questionnaires, and Analysis of Small Unit Combat Journals. The discussion of each of these includes an evaluative consideration of the advantages and disadvantages in terms of feasibility, cost and practical utility. The implications of task analysis of man-ascendant systems and machine-ascendant systems are reviewed. A major portion of the report presents results of statistical analyses of data from a task inventory designed to determine the tasks Intelligence Officers are performing now and those that they performed under combat conditions. The conclusions from our studies is that a questionnaire approach is probably the most feasible under peace time conditions, the least costly, and although contaminated by the possibility of faulty memories of respondents, still the method of most probable practical utility. Recommendations are given for construction of contingency task inventories and for further research by OMC.

ACCESSION FOR	
NTIS	White Section <input checked="" type="checkbox"/>
ONS	Self Section <input type="checkbox"/>
UNANNOUNCED	<input type="checkbox"/>
RESTRICTION	
BY	
DISTRIBUTION/AVAILABILITY CODE	
DISC	AVAIL. ONLY/SPECIAL
A	

**UNCLASSIFIED**

SECURITY CLASSIFICATION OF THIS PAGE(When Data Entered)

## SUMMARY

All Marine Corps Task Analyses of occupational fields performed to date have been conducted under peace-time rather than war-time conditions. The specific objective of research in this area was to determine the type of task analysis that would be effective in measurement of tasks that are not now being performed by Marines but would be performed by them in combat (under "contingency conditions").

This report evaluates traditional methods of contingency task analysis. Among the methods reviewed are Combat Simulation, Field War Games, Table Top War Games, Questionnaires, and Analysis of Small Unit Combat Journals. The discussion of each of these includes an evaluative consideration of the advantages and disadvantages in terms of feasibility, cost and practical utility. The implications of task analysis of man-ascendant systems and machine-ascendant systems are reviewed.

A major portion of the report presents results of statistical analyses of data from a task inventory designed to determine the tasks Intelligence Officers are performing now and those that they performed under combat conditions. The conclusion from our studies is that a questionnaire approach is probably the most feasible under peace time conditions, the least costly, and although contaminated by the possibility of faulty memories of respondents, still the method of most probable practical utility. Recommendations are given for construction of contingency task inventories and for further research by OMU.

PEACE-TIME TASK ANALYSIS AND  
ITS RELATION TO WAR-TIME CONDITIONS

Phillip J. Hanson and C. Harold Stone

Technical Report No. 12

A Research Project Supported By  
Commandant of the Marine Corps (Code RD)

And Monitored By  
Personnel and Training Research Programs  
Psychological Sciences Division  
Office of Naval Research  
Contract No. N00014-A-0436-0001  
NR 151-370

Approved for public release; distribution unlimited.  
Reproduction in whole or in part is permitted  
for any purpose of the United States Government.

California State University, Los Angeles Foundation

April, 1976

## TABLE OF CONTENTS

I.	BACKGROUND	1
	A. Evolving Project Objectives	1
	B. Goals of This Report	4
	C. Summary of Research Task Status	5
II.	GENERAL DEFINITION OF THE CONTINGENCY TASK ENVIRONMENT	10
	A. Men and Machines and the Contingency Environment	10
	B. Knowledge, Skill, and Performance	15
III.	CONTINGENCY TASK ANALYSIS METHODS	23
	A. Combat Simulation	23
	B. Field War Games	28
	C. Table Top War Games	30
	D. Questionnaires	31
	E. Analysis of Small Unit Combat Journals	33
IV.	EVALUATION OF TASK INVENTORY QUESTIONNAIRE METHODS	35
	A. General Critique of the OF 02 Officers Task Analysis Questionnaire	35
	B. Descriptive Analysis of the OF 02 Task Inventory	44
	C. Analysis of Significance	56
V.	CONCLUSIONS AND RECOMMENDATIONS	62
	BIBLIOGRAPHY	69
	APPENDICES	
	A. Sample Matrices For "Most Important" Task Statements	70
	B. Statistical Indices for Important Statements	76
	C. List of Most Important Task Statements	83
	D. Importance Index Values for Important Statements	86
	E. Characteristics of OF 02 Officers	89
	F. Statistically Significant $\chi^2$ Values	95

## I

### BACKGROUND

#### A. Evolving Project Objectives

Human behavior in a combat environment is both critical to planning for the military services, and it is immensely complex. Any project to study human behavior in combat is subject to all of the variations which may arise from the changing planning horizon for military services and the increasingly complex environment of combat operations and technologies. This can be the result of changed organizations and improvements in the technology of warfare. The present study deals with this complex and rapidly changing subject. It has experienced change resulting from evolving objectives induced by discussions between the Office of Manpower Utilization, HQMC (OMU) and the research staff and by changes in personalities associated with the research. This section provides a background to the evolution of study objectives as a context within which to consider the conclusions and recommendations that have resulted.

The original research tasks proposed for this Research Area define seven specific problems for research. These research tasks are:

1. Review literature and gather information on contingency tasks.
2. Develop assumptions about anticipated combat conditions.

3. Gather and analyze information on several representative scenarios.
4. Determine how combat conditions affect the "task set".
5. Attempt to formulate an alternative approach to Occupational Field (OF) Task Analysis.
6. Review findings with the office of Manpower Utilization.
7. Prepare a final report.

The overall goal of these tasks was to develop a new approach as an alternative to the present task analysis questionnaire. Fundamental to this new approach were data to be obtained from review of representative war games scenarios. It was intended to use these scenarios to conduct brain-storming sessions with personnel in the Marine Corps who possess combat experience, and then compare the results from these discussions with other personnel not possessing experience in combat.

This overall goal has been modified by two unforeseen developments. The first of these involves the security classification of "representative scenarios". Members of the California State University Research Team do not possess the security clearances required for access to classified Marine Corps materials, and, therefore did not have the opportunity to review classified war game scenarios which probably would have been the most fruitful to this research of any military scenarios that are available. Scenarios for war games were eventually obtained, but being un-

classified, they provided little substantive material for this research.

The second major development affecting the direction of this study was the choice of an approach to the task analysis of combat occupational fields based upon task inventory methods. After discussion of several alternatives with our research staff, OMU developed an experimental task inventory designed to include previous combat tasks as well as present duties in the task analysis of Occupational Field (OF) 02-- Intelligence Officers. We then recommended modification of our Study Plan to include an analysis of results of the Inventory with special attention to responses to questionnaire items describing combat tasks. The Commandant's Study Advisory Committee for our research project responded to our proposal as follows: "It is acknowledged that the problem of peacetime analysis of the combat MOS's is difficult. It is suggested that the remainder of available research time in Research Area 7 might best be devoted to an evaluation of the current task inventory of intelligence officers (OF 02) which provides a test of the feasibility of basing a task analysis on prior combat experiences".

As a result of these changes, the emphasis in research during this project has come to be heavily reliant upon the design and content of the OF 02 Task Analysis Questionnaire. This task inventory was divided into two parts, one to be administered to officers and one to enlisted men. The inventory for enlisted men in OF 02 followed the traditional methodology of

task analysis and did not concern itself with contingency task evaluation. Therefore, one direction of the research on this project, in terms of work undertaken by OMU, has been to analyze results of the OF 02 inventory for officer personnel in order to compare tasks performed under present peace-time conditions and those performed during combat. This emphasis resulted in a modification and expansion of the research tasks originally specified for this research area. These modifications were based upon the initial objectives of the research listed in the Study Plan, and are also based upon the experience with war games, combat simulation, and group performance under combat conditions possessed by members of the CSULA research team. As a result of this reorientation of research tasks, our analysis emphasizes a review of possible alternatives to contingency task analysis based upon staff experience, and a structure for further analysis of the OF 02 questionnaire.

B. Goals of This Report

There are three important goals which this present report seeks to attain. These goals are tightly interwoven with the original conception of research in this project, with the changes of direction that have been made as a result of modification of original research tasks, and because of the immensity of contingency task analysis, and its study, with comparatively limited funds.

The first goal of the present report is to address the seven tasks specified in the original work program by summarizing work accomplished on the original tasks. This report on project tasks

also includes a survey of alternative methods that could be used in contingency task analysis. The study is based in part on unclassified representative scenarios, and it also attempts to provide insights into the combat conditions or the characteristics of those conditions which affect the task set.

The second goal is to review the OF 02 Officer Personnel Task Analysis Inventory as it was constructed and administered during calendar year 1975. This review includes a discussion of the format and content of the questionnaire as well as a description of analysis of the results from administration of the OF 02 task inventory.

The third and most important goal is to provide some conclusions about future contingency task methods based upon a survey of those possible, available, or currently used by OMU.

C. Summary of Research Task Status

The original research design outlined work to be completed on seven tasks. The results of work on these tasks is reflected in the material provided in other sections of this report. To provide a context for the remainder of this document, a summary of project task status is provided below.

Task 1. Review literature and gather information on contingency tasks.

There is a very large volume of literature and data concerning the war-time or "contingency" operations environment. Much of this material is classified, and inaccessible to those not possessing an appropriate security clearance. In view of the constraints of the volume of this material, and

its security, work on literature review was approached in two ways. The first phase of Research Task 1 involved review of all available unclassified literature concerning the contingency environment available from the George Washington University Human Resources Research Office; the RAND Corporation in Santa Monica; the University of California at Los Angeles (UCLA); the Marine Corps Development and Education Command; and the Naval Research Center in San Diego. The material available from these sources suffered from all of the shortcomings associated with "general information". Nonetheless, it served to support and update opinions and facts available through the second approach.

A second phase added to Research Task 1 relied upon project team personnel experience in operations analysis of combat environments for other services. It was assumed that this experience would not be significantly different for the Marine Corps. The above noted experience, summarized here because it is the basis for some of the conclusions arrived at for this project includes:

- a. Design of a counterintelligence information system for the U.S. Army which required a knowledge of military intelligence operations.
- b. Analysis of armored combat operations in a CBR environment for the U.S. Army Combat Arms Research

Office. This work was based on scenarios of small group actions.

- c. Analysis of personnel and systems performance under simulated air combat conditions for the U.S. Air Force.
- d. Analysis of personnel and organizational performance of intelligence operations under combat conditions.
- e. Development of combat operations scenarios for the U.S. Army and U.S. Air Force.

The combination of these experiences generally covers the areas of Marine Corps operations and specifically those related to intelligence.

Task 2. Develop assumptions about anticipated combat conditions.

Assumptions about combat conditions may be categorized in several ways. The most elementary is by geographical area. Variation of geography introduces a range of possible assumptions concerning equipment, personnel performance, and the physical environment, for conduct of operations. Generally, these assumptions suggest that variation of physical environment involves concomitant variations in equipment and personnel requirements. The more severe the environment the greater are requirements, and larger requirements imply increased complexity of task performance. More complexity in performance requires an expansion of operations analysis to support training.

During this study phase, ways of categorizing the combat environment were reviewed as a means of developing

assumptions. Other ways of categorizing combat conditions are not documented here because they share important common ground with the most elementary category. For purposes of task analysis, this common ground involves specific variations in the human and machine aspects of combat. Section II develops definitions and assumptions concerning these aspects as a framework for conclusions regarding task analysis alternatives.

Task 3. Gather and analyze information on several representative scenarios.

Unclassified scenarios of field combat games were received from OMU and reviewed. In addition, experience with classified and unclassified Army and Air Force scenarios was used. As noted earlier, it was not possible to obtain classified Marine Corps scenarios.

Task 4. Determine how combat conditions affect the "task sets".

Sections II and III describe how various methods can be used to analyze knowledge, skill, and performance of various combat "task sets". The "task sets" are very generally defined as those that are man-ascendant, machine-ascendant, or some combination of the two.

Task 5. Attempt to formulate an alternative to OF task analysis.

This task was addressed by reviewing methods used by other military services to study combat that might be applicable to task analysis. Although there are a large number of alternatives, very few appear to be feasible. Consequently, much of the work on this task emphasized

critique of the task analysis inventory as an acceptable, but not entirely satisfactory alternative, and specifically emphasizes analysis of the OF 02 inventory results.

Tasks 6 and 7 involved coordination with OMU and preparation of project documentation.

## II

### GENERAL DEFINITION OF THE CONTINGENCY TASK ENVIRONMENT

#### A. Men and Machines and the Contingency Environment

There are a number of different approaches to description and discussion of the contingency task environment. The most conventional is structured around the principal areas of concern to military operations. These areas include strategy, tactics, logistics, organization, and administration. The literature on this conventional description and structure for the study of combat conditions has been extensively covered in the work of such organizations as The RAND Corp., in its analysis of Airforce strategy, the Combined Arms Research Office of the United States Army, in connection with its planning for and analysis of ground combat tactics, and the Institute for Defense Analysis. Since this approach to the contingency environment has been extensively covered elsewhere and since the financial resources available for this research project were not sufficient to cover that same ground, we have chosen to structure discussions of the contingency task environment in a more simplistic way, to take advantage of the work of others.

This structure is based upon the simple division of major components in the combat environment into those related to men and machines. This division emphasizes the two most obviously important ingredients of a discussion of the knowledge, skill,

and performance of military tasks in a combat environment. This division of combat conditions for purposes of analysis is not a novel one. It has been previously used with comparative success by the Human Resources Research Office (HUMRRO) of George Washington University.

In considering this dichotomy as a means for structuring a study of combat environments, it may be useful to review a definition of the two components. Brown and Jacobs have provided in their comments a reasonably good background and definition for this dichotomy. "It is significant to note that the training objectives for members of a machine-ascendant system may be ascertained largely from an analysis of the function of the machine; also, a criterion of satisfactory performance is readily available - the machine either works or does not work. To achieve the same ends for the members of the .... man-ascendant system is clearly more complex."<sup>1</sup> This brief commentary on the division which one may make between men and machines in a combat environment emphasizes the problems associated with analyzing any tasks in which primary concern is upon collective and individual human performance.

To the extent that any combat environment involves a large interplay between men and machines, the task of analyzing performance under these conditions devolves upon a careful balance in the analysis between the performance of men and the performance of machines as well as the performance of men and

1. Brown, Frank L., and Jacobs, T.O., DEVELOPING THE CRITICAL COMBAT PERFORMANCE REQUIRED OF THE INFANTRY RIFLE PLATOON LEADER, Human Resources Research Organization; Alexandria, Virginia. April 1956.

machines together. This division immediately suggests a three way categorization for structuring contingency task analysis.

1. Task analysis of human performance only. Such an analysis would emphasize tasks in which the activities of the human are dominant and in which human reliance upon machines to complete task sets successfully is minimal. These are referred to as man-ascendant tasks.
2. Analysis of machine performance. Such an analysis is part of the extensive program of military hardware procurement which provides assurance regarding equipment performance under various operational and environmental conditions. While this is not strictly speaking "task analysis", it is, nonetheless an important component and a necessary factor in that analysis.
3. Task analysis of performance in which successful completion of activities is dependent upon man and machine working in concert, but is most heavily dependent upon machine performance, i.e. a machine-ascendant system of tasks.

Clearly the Marine Corps must make provision for training and performance in an environment that includes men and machines in many task combinations. Task analysis must make the same provision. However, it is reasonable to expect that no single methodology can conveniently and inexpensively accommodate all task combinations. This means that one methodology should be

chosen that is optimum in terms of cost and still fulfills task analysis requirements. The available methodologies can be conveniently discussed using the general categories provided above.

Analysis related to machine performance may be considered as a given to the task analysis environment. It must be assumed that equipments fulfill minimal requirements for operation and that all of the operating characteristics can be known in advance. This may seem a statement of the obvious. However, the essence of contingency environments is the expedient use of available resources whose operating characteristics may not be known. Nonetheless, performance is required for survival, a situation that severely tests adaptability in the application of learned tasks.

In using unfamiliar equipment there is a whole task set associated with expedience that is not trained for in peace time but that may be required under contingency conditions. We must not only assume that some of these tasks cannot be trained for even if known, but that many cannot be known beforehand. Consequently, it may be necessary to approach the task analysis of contingency environments with a realistic admission to a large area of ignorance. This area of ignorance could only be adequately explored by a large investment of funds. For example, to train for knowledge of weapons "left in the field" would require a vast store of data concerning performance characteristics of individual weapons from various

countries. An example of this sort of investment is the Air Force Semi-Automated Ground Environment (SAGE) system which is discussed briefly in Section III of this report.

In defining the man and machine characteristics of the combat environment, task analysis that emphasizes "machine-only performance" may be tentatively eliminated as being both incomplete and expensive to implement. At the other extreme in ways of viewing the combat environment is that which emphasizes man, i.e. is man-ascendant. In this view, task analysis would emphasize the successful completion of tasks which rely almost exclusively upon the human. "Table top", "desk top", or "command post exercises" are characterized by their emphasis upon human performance and decision-making. Machine availability and performance are simulated in these exercises as externalities or givens to the operating environment. The purpose of such exercises, and therefore of task analysis in such an environment, is to evaluate the performance of the human in assigned sequences of tasks when presented with carefully controlled inputs from an external set of performance circumstances. Games of this sort, also discussed in Section III, can be conveniently repeated, and the external performance circumstances finely permuted as a means of training for or analyzing performance on combat task sets under widely varying assumptions.

Viewing the combat environment with emphasis upon man is more realistic than machine-only analysis, and task analysis

that emphasizes human performance, i.e., is man-ascendant, is more directly related to "the tasks Marines perform". It does not, however, contain the ingredient of technology which reflects the contemporary combat environment that is so heavily reliant on modern machines. Consequently, analysis of contingency tasks must in some way make provision for men and machines operating in concert. In addition, analysis must carefully distinguish between machine-ascendant tasks and man-ascendant tasks.

This distinction is important since constraints and requirements for men vs. machine-ascendant tasks are very different. For example, man-ascendant task sets are relatively invariant with respect to theater of operations while machine-ascendant task sets are not. This simply means that there would be some experience "transfer" possible. This combination of requirements makes for the most difficult possible task analysis environment. Nonetheless, the three-fold view of task analysis provided above supplies a structure for evaluating approaches to contingency task analysis. We must now consider machine-ascendant tasks and man-ascendant tasks in a man-machine environment.

B. Knowledge, Skill, and Performance

We shall distinguish these terms on the following basis. Knowledge is the set of data acquired by a human concerning a task or equipment through instruction in a shop or classroom setting. Knowledge may never be used, i.e., it may retain its academic status. If knowledge is effectively used in performance, it constitutes a skill. The more frequently knowledge is used,

the more proficient become the skills they represent. Skills are developed either through training or use in real life settings. Performance is the execution of a skill in response to specific stimuli. There are two dimensions to performance -- one is whether a learned skill can be executed or not, and the other is whether the skill can be executed with some degree of proficiency, i.e., "the level of performance is high".

Where there is long experience in performance of a skill, there is a greater possibility for increased proficiency and operating knowledge. Contemporary combat may or may not offer the opportunity for long periods of time in which experience may lead to proficiency. Vietnam offered the possibility of long-time experiences where the man-machine interdependence was heavily tested. Air combat, on the other hand, is characterized by short time-experience exposure. Accurate memory of combat performance would generally be directly related to length of time-experience exposure. This memory could be used as the basis for task analysis, and in OF 02 it has.

The point to be made is that task analysis in the combat environment, whether machine- or man-ascendant, is possible only based upon the record (memory) of combat actions, upon accurate simulation of those actions, or upon analysis of those actions as they take place. The latter has generally been found to be impractical. Consequently, task analysis can only be based upon memory (record) or simulation.

Figure 1 is presented in an effort to develop a framework

within which to discuss alternatives in contingency task analysis. This figure schematically presents a three dimensional relationship between the various types of operational environments and the knowledge, skill, or performance required in those environments in terms of tasks which either are man-ascendant or machine-ascendant. This figure is intended to help focus upon the areas of concern within contingency task analysis. In this way it should be possible to eliminate methodically those which are of no concern to the combat environment and to evaluate carefully and discuss those which are of concern.

It is difficult arbitrarily to divide things in this fashion since it is evident that all of these factors derive from experience which precludes any sharp lines of demarcation between them. For example, the classroom experience and the knowledge gained in it will eventually, or in part, see itself reflected in performance in combat environments. Furthermore, information garnered in the classroom regarding machine-ascendant tasks will certainly have an impact upon the activities that one performs in man-ascendant tasks. However, this does provide us with the necessary decision rules.

For purposes of this discussion it is assumed that it is possible in the classroom environment to conduct tests of man-ascendant and machine-ascendant tasks to determine the level of knowledge acquired by Marine Corps personnel. Where the classroom is a shop and the function is primarily machine-ascendant, of course, there is an opportunity to evaluate the

		III PERFORMANCE		
		II SKILL		
I KNOWLEDGE		1	2	3
		CLASSROOM	GARRISON	COMBAT
A MAN-ASCENDANT	Knowledge Acquired (I) Some Skills Testable (II) No Capability to Measure Performance (III)	Knowledge Acquired (I) Many Skills Testable (II) Some Capability to Measure Performance (III)	Knowledge Acquired (I) Few Skills Testable (II) Complex Performance Measurement (III)	Knowledge Acquired (I) Some Machine Skills Testable (II) Average Complexity for Perform. Meas. (III)
B MACHINE-ASCENDANT	Knowledge Acquired (I) Many Machine Skills Testable (II) Some Performance Measurement Possible (III)	Knowledge Acquired (I) Many Machine Skills Testable (II) Some Performance Measurement Possible (III)	Knowledge Acquired (I) Some Skills Testable (II) Complex Performance Measurement (III)	Knowledge Acquired (I) Some Skills Testable (II) Very Complex Performance Measurement (III)
C MAN-MACHINE COMBINED	Knowledge Acquired (I) Some Skills Testable (II) Some Performance Measurement Possible (III)	Knowledge Acquired (I) Some Skills Testable (II) Complex Performance Measurement (III)	Knowledge Acquired (I) Some Skills Testable (II) Very Complex Performance Measurement (III)	Knowledge Acquired (I) Some Skills Testable (II) Very Complex Performance Measurement (III)

Figure 1. Relationships In Task Analysis Between Men Or Machine Systems; Knowledge, Skill, Or Performance Levels; and Operational Environments.

skill acquired in the performance of machine-related tasks. In like manner it must be assumed that knowledge, skill, and performance of man in machine-ascendant tasks can be evaluated in a peace-time setting. The principle function of task analysis to this point has been the evaluation of this segment of the environment. It should be pointed out that in this environment, however, the thing that is being sought is not the proficiency of performance of various machine- or man-ascendant tasks in the peace-time operational environment but the determination of whether the tasks are performed at all and roughly what proportion of time is spent in the performance of those tasks.

The focus of our attention, therefore, is the task analysis of knowledge, skill, and performance for man-ascendant and machine-ascendant tasks in the combat operational environment.

It is not too difficult to determine the extent of the knowledge possessed about machine-ascendant or man-ascendant tasks in the combat environment. The main difference between making a determination of knowledge of the combat environment as opposed to evaluating the same sort of knowledge in a classroom setting is in the tools used. In the classroom setting the evaluation of tasks is broken down into the component areas of knowledge without regard to the operational environment in which the knowledge may potentially be used. Tools traditionally used are test questions. However, the determination of knowledge possessed about the combat environment can only be obtained through a very

special kind of test. This sort of test is not infrequently used and is referred to as a game. Games and their use are discussed in a later section of this report.

As we go down the ladder of knowledge, skill, and performance in the combat environment, we discover that any evaluation of the level of proficiency possessed in these areas becomes increasingly difficult. For example, the determination of skills possessed by Marine Corps personnel in the machine-ascendant tasks in the combat environment is more difficult than assessing the knowledge of machine-ascendant tasks and machine operations under combat conditions. And, testing for performance in man-ascendant and machine-ascendant tasks in a combat operational environment is the most difficult. However, it is what Marines actually do in their performance of tasks that is the subject matter of task analysis. Therefore, when discussing combat operations, the focus of attention must be on the actual tasks performed. In studying man-ascendant and machine-ascendant tasks in the combat environment, obtaining reliable data on tasks performed appears to be more difficult for man-ascendant than for machine-ascendant tasks. As noted earlier, the operations of machines possess parameters that may be fairly readily delimited for a wide range of operating environments. The same is not the case with a man. Contingency situations elicit expedient human responses, and task analysis as now conducted makes no provision for this.

From another point of view the experience obtained by Marine Corps personnel under combat conditions constitutes a body of knowledge for which, in similar circumstances, skill and therefore, proficiency in performance would be greater. This means that another dimension to the evaluation of performance is to anticipate the ways in which performance under prior combat conditions would apply to or be similar to combat operational conditions in a subsequent time. This knowledge is important because task analysis must provide some means of continually evaluating the tasks that Marines actually perform. However, task analysis does not attempt to evaluate the proficiency of performance of skills. Its primary concern is whether or not the task was actually performed and what percentage of time was spent in performance of the task.

Within this framework we have provided some rough ideas of the relative complexity of evaluating knowledge, skill, and performance of man-ascendant and machine-ascendant tasks. This description of the task analysis environment also provides a structure within which to apply the various types of analytical tools that may be available. These tools range on a scale of complexity from comparatively simple to very complex. Furthermore, they provide very few alternatives for clearly distinguishing in any black and white fashion between different levels of the testing environment.

Another dimension in the consideration of the tools that are available is the relative cost of their use. It would not

be difficult to simulate almost completely many combat conditions for both man- and machine-ascendant tasks, but the simulation itself would entail a prohibitive cost. The evaluation of alternatives for task analysis in a combat environment must consider not only whether the analysis is possible, but whether it is financially feasible.

### III

#### CONTINGENCY TASK ANALYSIS METHODS

This section provides a brief description of the alternative methods that can be used to conduct contingency task analysis. The methods range over a wide spectrum. They include those methods which are highly complex and very costly, as well as those that are relatively simple and inexpensive. Among the methods included are the present task analysis questionnaire approach. All of these alternatives are discussed in terms of the framework presented in Section II. It is obvious, but should nonetheless be pointed out, that this discussion of a set of methods is painfully brief by comparison with the amount of consideration that should be provided. It is, however, based on broad experience with these methods among intelligence agencies, the military services, and emergency preparedness agencies in the U.S.

##### A. Combat Simulation

Simulation is one of the most precise, most flexible, and also one of the most expensive methods that can be used to evaluate task performance under combat conditions. Flexibility of simulations is inherent in the fact that the inputs and outputs of the environment are synthesized, or result from an interaction with a simulated, self-contained environment. However, because such a large number of variables must be manipulated in the simulated environment, the cost of simulation is generally

quite high. An example of a successful system of simulation of combat conditions that involves man-ascendant and machine-ascendant tasks is the Semi-Automated Ground Environment (SAGE) system of the Air Defense Command (ADC). This system provides the capability for simulating all or a part of the real environment as a means of evaluating combat policies. This simulated environment also provides the opportunity to evaluate the knowledge, skill, and performance of tasks under expedient circumstances for all personnel participating in the simulation.

Participation in this simulation may include only a few personnel performing tasks in a limited area at one base, or it can be adapted to accommodate a simulated strategic and combat operational environment for the entire continental United States. This task analysis environment is based on the operation of simulated inputs generated and managed by a very large network of computers. The interactions with that environment takes place in a controlled environment that replicates the operational environment for Air Defense Command personnel. All of the results of the interactions between simulated situations and the personnel in the system are recorded on magnetic computer tape. Subsequent to a simulated exercise this tape can be analyzed so that the results of overall knowledge, skill, and performance in the combat situation can be displayed on cathode ray tubes. The same sort of analysis is possible for each of the positions (MOS's) operating within the environment.

There are a number of other similar simulation capabilities which have been tried for those environments that are heavily machine-ascendant. In the Air Defense Command, for example, the principle components are high speed aircraft, radars, and missiles. The same thing is true of the Navy Tactical Data System (NTDS) which is designed for operation and simulation of combat on highly mechanized combat ships, interacting with a highly mechanized environment including attacking aircraft, ships, and missiles.

Figure 2 is a paradigm of these types of task analysis environments. It must be borne in mind that weapons assignment and target detection are complete task sets in a contingency environment. Furthermore, other combat task sets are implied in this figure but only represented by those shown. In the real world all of the physical and task variables of target detection are processed by the computer for use in the weapons assignment task set. The unique feature in this setting is use of a computer to connect these two task sets. The presence of the computer also is an asset in the simulated world, i.e., all physical and task variables for targets can be stored on computer tape both to train the weapons assignment task set, and to analyze very nearly real performance (task analysis) on this task set.

The above are two examples of simulations of combat in which the entire environment system can be simulated as well as component individual performance within that environment.

COMBAT ENVIRONMENT

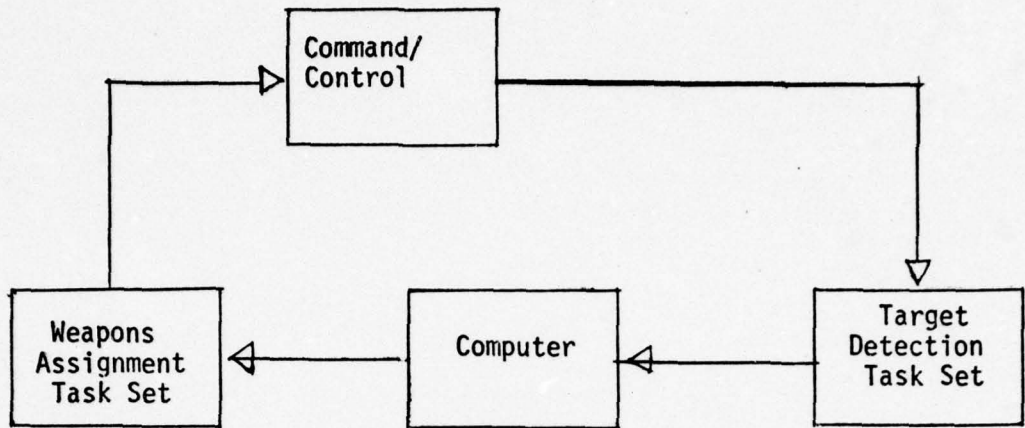

SIMULATED COMBAT ENVIRONMENT

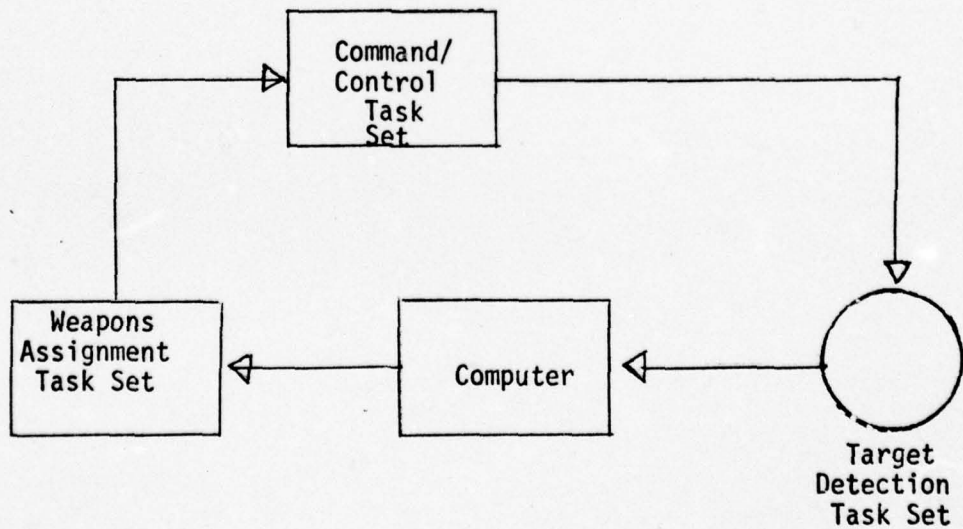

Figure 2. Comparison of Combat Task Analysis Environment and Simulated Combat Task Analysis Environment

There are innumerable examples of simulations that also involve activities of a single individual or component operating with a single piece of equipment. This sort of simulation, for example, takes place in aircraft trainers, or ground equipment trainers. These trainers are electromechanical equipments that provide a means for completely simulating the performance of hardware under various conditions and interacting with the human being controlling the hardware. Once again, as with the combat simulations of the larger combat environment, it is possible to control carefully the inputs and therefore to evaluate the outputs of the entire activity because the trainers or simulators are generally based upon an event-recording capability using computers.

To the extent that personnel in the Marine Corps are involved with the same sorts of equipments being tested or simulated in the Navy Tactical Data System or the Semi-Automated Ground Environment, the Marine Corps would have a capability for conducting task analysis under simulated conditions to evaluate what Marine Corps personnel may actually do. However, it must be emphasized that the simulation would provide a mechanism for looking at what personnel may do but not necessarily what they actually would do in combat. In addition, the use of either of these two systems requires an extensive amount of planning of the simulated environment, an extensive training of personnel to participate and work with the simulation mechanisms, and a broad capability to conduct

an analysis of the results of the use of this simulation approach to task analysis.

B. Field War Games

Field exercises, war games, or field war games offer other possibilities for conducting task analysis under approximation to war-time conditions. The Marine Corps currently conducts these games or is involved with them through other services. The essence of this approach to task analysis is the use of a set scenario on the basis of which an entire combat exercise is conducted. The scenario attempts to make provision for those stimuli within a "game" environment that would normally be encountered only during war-time. The purpose of the entire exercise is to provide a means for personnel operating individually and as groups to respond to these stimuli in an appropriate fashion in order to obtain training in activities that are approximations to those that may be encountered in war-time conditions.

Games of this type are conducted periodically in environments throughout the United States and the world in attempts to simulate in the game environment what is expected to occur in a potential combat environment. We are not aware of efforts to use the war games setting as a means for evaluating or conducting task analyses of what Marines actually do under such simulated combat conditions. Both combat simulation and field war games are potentially ideal settings for analysis of tasks performed by Marine Corps personnel that are both man-ascendant

and machine-ascendant. However, the mechanism that would have to be employed in field war games to collect data as to what Marines actually do would be fairly difficult, especially if the method chosen is the task analysis process as presently applied.

There are alternatives in connection with an approach of this sort. These involve collecting tapes and films of Marine Corps personnel performing various task sets in the field, i.e., in the war game. These task sets could be reviewed as a function of the way in which combat environment stimuli change over time. Data collected in this fashion could provide insight into the way in which task sets change as a function of a combat operational environment.

Field War games employing set scenarios have been used extensively, and the military services, including the Marine Corps, have broad experience with this approach. Field War games are generally more expensive than the use of combat simulations. It means essentially making provisions for the fielding of an entire set of units to operate in a manner that would be consistent with established strategic or tactical policy in order to evaluate the performance of tasks in this setting. These games are planned regularly as training exercises and their use to develop task analyses would be an added feature of the game. The added feature could involve use of films, audio-tapes, video tapes, and logs to collect data. These data could then be used for analyzing the tasks

that marines actually perform in a field game environment.

C. Table Top War Games

Table Top War games are usually conducted in facilities remote from an actual combat environment. These games include the use of scenarios on the basis of which personnel perform sets of tasks. Inputs from other organizations, groups of people, or performance of equipment, are provided in a synthetic fashion, as part of the setting for the war game or as paper transactions during the conduct of the war game. The intention of the war game is to create conditions similar to a combat decision-making environment by providing stimuli that approximate those encountered in a war-time setting. Unlike field war games and combat simulations, table top war games are primarily designed to emphasize man-ascendant tasks. In these games, data concerning the performance of hardware is provided in a synthetic fashion. This approach does not include many of the circumstances that could cause the performance of hardware to vary beyond known parameters.

Table top war games are generally conducted in rooms designed for that purpose. The activities or the tasks of the game are conducted by use of both printed scenarios and printed messages which are transmitted into or out of the room during the conduct of the game. The only ingredients that are used in the game are the individuals participating in the game plus paper messages. In many respects these games are expanded versions of games such as "Risk" or "Monopoly".

Table top war games generally tend to be less expensive in terms of resources required. However, in order realistically to approximate combat conditions, a great deal of research and design attention must be given to the actual characteristics of past combat environments as a means of analyzing performance in the current game setting or as a means of training for future situations of a similar nature. The transmission of decision-making sets by way of typed messages in this type of war game provides a certain artificiality that cannot be circumvented. Thus, in addition to the reasonably low cost of these games, one would have to add the disadvantage that they are not nearly as realistic as field war games or combat simulations.

D. Questionnaires

It is possible to conduct contingency task analysis using questionnaires or task inventories. The use of questionnaires for this purpose would be (1) to determine what experiences Marines have actually had in the performance of a set of tasks under combat conditions or, (2) to evaluate what they believe they would do under specified combat conditions. In the first case, questionnaires based on experiences in combat situations are limited to those who have actually been in combat. It is this approach that was used by OMU in the OF 02 officer task analysis inventory. In the second case, combat tasks would be analyzed on the basis of what Marines trained in particular combat settings believe they would be doing if exposed to such conditions.

The use of task inventories or other questionnaires has shortcomings in both cases. Perhaps the most reliable is use of a questionnaire with those who have had combat experience. This is another way of saying that the sample is limited and biased in favor of experience in a specific combat setting. It may be assumed that experiences in combat conditions gained in Korea do not apply to those gained either in Europe or in Vietnam. Consequently, it would be difficult to evaluate what tasks are actually performed under combat circumstances without careful attention to the environment in which the tasks were performed. Using questionnaires only on the basis of what personnel believe they would do in combat situations is not adequate since it would never reflect all of the many variables which enter into combat situations that cannot be anticipated beforehand.

There are several distinct advantages in the use of questionnaires. The first of these is that the Office of Manpower Utilization has experience with the use of the task inventory approach to task analysis. A second benefit is that while questionnaires regarding experience in combat are circumscribed by certain limitations, they do reflect what a Marine recalls he actually did under specific combat circumstances. This advantage is one that does not exist in any of the other task analysis methods described in this section. A third benefit is that the use of questionnaires is significantly less expensive than the use of combat simulations, table top war games, or field

war games.

The principle disadvantage of the questionnaire approach is that special care and attention is essential in selecting the most suitable and effective analytical methods upon which to base conclusions about task performance. These analytical tools, i.e., statistical techniques, are highly complex. They require both a careful experimental design, including explicit hypothesis formulation, as well as application of appropriate methods to provide the basis for judgments concerning results.

Recently OMU has used the questionnaire method to analyze combat experience. Since this is the first occasion on which a task inventory has been used to analyze combat tasks by OMU, it is important to evaluate the results. A more detailed analysis of this experiment is discussed in Section IV.

#### E. Analysis of Small Unit Combat Journals

Historically, the performance of small units in most combat environments in the various services has been recorded as small unit journals or records of action. These records of action provide a basis upon which to be completely analytical about what tasks Marine Corps personnel do perform under real combat situations. Records of this type provide a history of action under combat conditions in a specific part of the world at a specific time and contain data for evaluating the types of tasks that were performed within that setting.

The disadvantage of this approach is that combat journals are incomplete from a number of points of view. The first

source of incompleteness is the lack of detailed knowledge about the tactical setting of the combat situation in which tasks were performed. The second shortcoming is that the records do not provide detailed insights into the types of Marines who performed the tasks in those settings. The third disadvantage has to do with the difficulty of interpreting records by individual analysts where it is not possible to use an explicit and objective analytical tool. The subjective judgments of those reading the small unit action record could introduce interpretations of task performance that might lead to erroneous conclusions.

In spite of these disadvantages, small unit records have been used in the past with some degree of success in the construction of an environment conducive to task analysis of combat activities. This work was done by the Human Resources Research Organization (HUMRRO) for the United States Army.<sup>2</sup> HUMRRO's approach was to evaluate small unit records as a basis for selecting out task sets which could be then reviewed either in a testing situation or could become part of a field war game or a table top war game.

2. Brown, Frank L., & Jacobs, T.O. Developing the Critical Combat Performance Required of the Infantry Rifle Platoon Leader. Human Resources Research Organization; Alexandria, Virginia. April 1970

#### IV

#### EVALUATION OF TASK INVENTORY QUESTIONNAIRE METHODS

This section reviews a number of technical problems in the use of questionnaires to conduct contingency task analysis. It is based heavily upon the review of analysis methods in Section III and upon the OF 02 Officers Questionnaire. In response to the direction provided by Headquarters, U.S. Marine Corps, emphasis in the discussion that follows is upon evaluation of the OF 02 Task Analysis Questionnaire.

##### A. General Critique of OF 02 Officers Task Analysis Questionnaire.

Generally, the critique of the OF 02 Officers Questionnaire must address questions that are common to questionnaires administered to all occupational fields. These common areas are even more significant when they are related to the comparison of garrison with combat duties. The ultimate question that should be addressed in the critique of the OF 02 task inventory can never be adequately answered. That question is the degree to which responses to this questionnaire are reliable indicators, or provide specific facts, about what a Marine actually does under combat conditions.

This general critique is provided as background to data presented and analyzed later in this document. In many respects comments that are offered below also describe limitations and constraints on the quantitative data provided. Thus, in determining what the Marine actually does in combat, the most sig-

nificant question is do the data that have been collected for OF 02 Officers have any meaning? Hopefully, the meaning of the data will become clear in the context of the items in the critique below and discussed as part of the analysis of OF 02 data.

1. Man-ascendancy in task inventory questions.

In an earlier section of this report, differences between man-ascendant and machine-ascendant tasks were described. Some of the differences are due to the fact that machine-ascendant tasks are explicit and closely circumscribed by the operating characteristics of equipment. All other things being equal, the performance of different types of equipment under combat conditions is reasonably predictable within the operational limits of equipments. Past history and future performance can be anticipated with some degree of assurance. The margins for interpretation about equipment are fairly delimited, and those tasks which are machine-ascendant are also fairly well delimited. This means that there is a comparatively limited opportunity for subjective opinion about machine-ascendant tasks. This minimal amount of subjectivity offers opportunities for humans to maintain a reasonably continuous record of behavior in connection with machine-ascendante tasks.

The same is not true of man-ascendant tasks. Man-ascendant tasks are much more variable and subject to

interpretations that are functions of the terminologies used. Consequently, one of the significant features of the present questionnaire is determined by the extent of its orientation to man-ascendant tasks. The OF 02 questionnaire has 614 task questions. Five hundred and eighty-seven questions, or 96%, are either largely or exclusively man-ascendant. These are tasks for which hardware is either not required or in which the reliance upon hardware is at a minimum. The remaining 27 tasks, or approximately four percent of the total, are either machine-ascendant or involve some combination of man and machines. Ten of these 27 tasks were found to be significant from some other point of view, as discussed in Section IV, B, beginning on page 52.

The dominance of man-ascendant tasks in this task inventory suggests a number of things. First, inventory results may be biased by the subjective opinions and interpretations placed upon the tasks by the persons to whom the questionnaire was administered. Asking a subjective question clearly entails the risk of receiving a subjective response. Thus the data that could be obtained from such questions are open to a wide range of interpretations, a concomitant of the subjectivity of the question.

Secondly, the time spent on tasks of a subjective nature, i.e. the "task time exposure", is also subject to an intuitive interpretation. It would generally be true,

for example, that participation in the system where tasks are primarily machine-ascendant would lead to a time exposure to activities that have less opportunity for interpretation, and therefore the precision of memory in terms of the time exposure will be much higher. The two important dimensions in man-ascendant tasks are that they are subjective and that their subjectivity has temporal and textual context.

2. Temporal context.

Utilization of an ordinal scale of 1 to 7 to rank relative time spent on a task implies that there is a reasonably precise memory or definition of the amount of time that is actually spent. If we assume that the average individual is faced with ranking 614 tasks in terms of the amount of time he has available to perform those tasks, there would be approximately two minutes per task that individual respondents would be able to spend on each activity in one 40 hour week. However, since there is no reference point for the temporal ranking, there is also no opportunity for relative comparisons of amounts of time spent. Another way of saying the same thing is to ask whether in the mind of the respondent there is a relationship between a 1 response (very little) and 0 time spent. At the other extreme, does a 7 level response indicate the expenditure of in excess of two minutes per task, or does the relative ranking skew the responses heavily in the direction of

indicating the importance of the task?

It is concluded that there is no temporal reference point for the response scale for the questions in the OF 02 questionnaire. Without this temporal reference, there is no way for relating time spent on all 614 tasks as a description of a complete task set for individual officer personnel. Without this temporal reference it is difficult to develop any appreciation for those things that a Marine actually does in garrison conditions, let alone under combat circumstances.

3. Textual Reference.

The difficulty of dividing questions in the questionnaire between those that represent tasks and those that represent elements is equivalent to dividing tasks between those that have highly specific meaning in terms of the words used and those that have a fairly general meaning. This essentially boils down to the significance of the difference between questions on the same general subject where terms that possess no precise context are used. In the minds of many people, there may be little difference between supervise, conduct, perform, review, request, screen, or maintain, as verbs that qualify questions about specific activities. Conversely, the same verbs may provide a task orientation set that would imply to officer personnel a different interpretation of task statements than for enlisted personnel. Those tasks in which officers may be actually conducting or

performing work could be viewed differently than those in which they are identified as performing supervisory tasks. There does not appear to be a contextual reference or standard for the adjectives and adverbs used in task statements preceding specific task definitions. The generality of each term introduces an ambivalent interpretation that is a function of the perception of the individual reading the task statement.

4. Length of Questionnaire.

In well designed experiments in the social and the physical sciences it is usually desirable to have more experimental points than experimental measurements. In the case of the OF 02 Officers Questionnaire the number of experimental measurements (614 questions) is far in excess of the number of experimental points (220 respondents). This excessive number of experimental measurements introduces a number of both technical and psychological variables. On the technical side, an excess of experimental measurements introduces the possibility that many of the sets of tasks are essentially null or empty sets. They contain either no responses that can be measured or contain such a small number of responses that they possess little if any statistical significance. On the psychological side, the excessive number of measurements in this case introduces the chance for question fatigue. The very large number of measurements for the fairly limited number of points introduces a number of

variables that are difficult to control. In future development of questionnaires similar to the OF 02 inventory, it would seem desirable to adhere to the general rules followed by work such as that of Stouffer in the "Studies in Social Psychology in World War II".<sup>3</sup> These rules are considered applicable to task inventories in spite of the fact that Stouffer's study of a very large population emphasized motivation more than performance of tasks.

5. Sample size.

A typical problem in survey sampling is to determine the proportion of a population who possess a characteristic. In mathematical language, we are interested in obtaining an estimator  $p$  of the population proportion  $P$  by sampling  $n$  persons out of the total population of  $N$  persons. The usual model for a solution is to allow a margin for error in the estimator  $d$ , and a probability  $\alpha$  of exceeding that margin for error with the estimator. The sample size is then established so that the probability that the estimated value  $p$  differs from the population value  $P$  more than  $d$  is less than

$$\text{Prob } \left[ |p - P| > d \right] \leq \alpha$$

From statistics we can learn that

$$\frac{P-p}{\sqrt{\frac{N-n}{N-1} \cdot \frac{P(1-P)}{n}}} \text{ is a}$$

normal variable on  $Z$  score. Thus we have that

$$d = Z_{\alpha/2} \sqrt{\frac{N-n}{N-1}} \sqrt{\frac{P(1-P)}{n}}$$

where  $Z_{\alpha/2}$  is the abscissa of the normal curve which has probability  $\alpha/2$  in each tail.

3. Stouffer, Et Al., STUDIES IN SOCIAL PSYCHOLOGY IN WORLD WAR II, Volume II, "The American Soldier: Combat and It's Aftermath". Princeton University Press, 1950.

If we solve the above expression for  $n$ , we get

$$n = \frac{N}{1 + \frac{d^2}{(Z_{\alpha/2})^2} \cdot \frac{N-1}{P(1-P)}}$$

Since  $P$  is unknown, this expression is not useful for determining the sample size  $n$ . If we observe that  $P(1-P)$  is always less than or equal to  $\frac{1}{4}$  for all  $0 < P < 1$ , we obtain the conservative solution

$$n = \frac{N}{1 + \frac{d^2}{(Z_{\alpha/2})^2} \cdot \frac{N-1}{\frac{1}{4}}}$$

which is larger than any solution for known  $P$ . So if we sample

$$\frac{N}{1 + \frac{d^2}{(Z_{\alpha/2})^2} \cdot \frac{N-1}{\frac{1}{4}}} = n \text{ of the population}$$

then we can determine that the probability of the estimated proportion differing from the true proportion by more than  $d$  is less than  $\alpha$ .

The expression above for determining the sample size is very unwieldy; but there is a useful approximation to it, if  $N$  is large. In this case, we consider  $\frac{N-n}{N}$  equal to 1, which will cause an error in the determination of  $n$ . If  $N$  is 10 times  $n$ , there will be an error in the solved sample size of approximately one percent; but since we had a con-

servative sample size initially, this error is usually unimportant.

The approximate formula is 
$$n \leq \frac{(Z_{\alpha/2})^2}{4d^2}$$

Using this approximation and some usual values for  $d$  and  $\alpha$  we can see their effect on the sample size.<sup>4</sup>

d	.10	.05	.02	.01
.10	68	96	135	166
.05	270	384	543	666
.02	1691	2401	3399	4160
.01	6765	9604	13572	16641

As can be seen from the table, as the requirements for accuracy of the estimated proportion and the probability of making an error become more stringent, the sample size quickly becomes excessive. A compromise must be made between the useful accuracy of the estimators and the cost of sampling to obtain these estimators. The most common choice is to allow a five percent possibility of making an error in excess of five percent; this choice requires a sample size of 384. Viewed in this way the OF 02 sample of 116 cases introduces a fairly large probability of introducing an error in the data of 10% or more.

These comments or critiques of the OF 02 questionnaire provide a background for the subsequent discussion. The

effects of the factors reviewed in this general critique

4. We are indebted to Dr. Robert Juola, Mathematics Department, Boise State University, for describing derivation and application of the statistics on sample size in this Section.

introduced a large number of uncontrollable influences in the OF 02 questionnaire results. These uncontrollable influences in turn cause a fairly high degree of ambivalence in the interpretation of both the descriptive data for the OF 02 questionnaire and for the statistical analyses that have been performed on the questionnaire results.

B. Descriptive Analysis of the OF 02 Task Inventory

1. Methodology for analysis.

The methodology chosen for descriptive analysis of the OF 02 questionnaire was intended to provide a minimal basis for evaluation of the data collected. It relies upon the interpretation of simple statistics, such as the level of responses by individuals to task statements in the questionnaire, computation of index numbers to measure relative importance of characteristics for each task statement in the questionnaire, a review of question phraseology and review of the underlying similarity of those questions possessing important characteristics in common.

The methodology employed in completing this analysis was to write a computer program that processed the OF 02 tape received from OMU. This computer program was designed to produce 614, 8 x 8 matrices. One matrix was produced for each of the 614 questions in the OF 02 questionnaire. The matrix provides for eight levels of response for each task statement describing combat activities and eight levels of response for garrison duty. These eight levels of response

are based upon the 7 point scale used in the questionnaire plus a zero category for those tasks that respondents indicated they do not do now or did not do under combat conditions. An example of this is the 8 X 8 matrix for one of the significant questions is shown in Figure 3. A set of these matrices, for several of the most significant questions, is reproduced in Appendix A of this technical report.

Sample size is a factor that has influenced much of the interpretation of our analytical studies. A sample of 116 cases was taken from the tape of data supplied by OMU. This sample contained officers who had responded to both garrison and combat questions based on experience. This group originally numbered 125, but nine of these were not used for technical reasons. This sample was in turn taken from the complete group of 220 respondents of which 32 were between assignments and did not respond to garrison questions; and 63 did not respond to combat questions because they possessed no combat experience. Consequently, the 116 officer sample consists of those possessing both combat and garrison experience.

As noted earlier, a population of this size introduces a high probability of a sampling error of 10 percent or more. This source of error is mitigated somewhat by the apparent high percentage that the 220 respondents constituted of the total complement of OF 02 officers at the time the questionnaire was administered. In spite of this, 116 experimental

"8x8 Response Matrix"

QUESTION #	IN COMBAT							TOTAL		
	0	1	2	3	4	5	6			7
0	88	2	0	3	2	0	3	3	101	Intensity Index
1	3	8	1	0	0	0	0	0	12	
2	1	0	0	0	0	0	0	0	1	
3	0	0	0	0	0	0	0	0	0	Homogeneity Index
IN GARRISON										
4	1	0	0	0	0	0	0	1	2	
5	0	0	0	0	0	0	0	0	0	
6	0	0	0	0	0	0	0	0	0	
7	0	0	0	0	0	0	0	0	0	
TOTAL	93	10	1	3	2	0	3	4	116	

	In Combat	
In Garrison	108	8
	1	1

"Collapsed Matrix"

Figure 3 Examples of 8x8 and Collapsed OF02 Questionnaire Response Matrix

points is small by comparison with the number of experimental measurements, and the size of the 8 x 8 response matrix. These constitute a constraint on even elementary statistical tests. For example, the  $X^2$  test should generally not be applied to classes of data for which the expected value is less than five. An 8 x 8 matrix would require 320 values. To compensate for this, the matrices were collapsed to 2 x 2 as shown in the lower part of Figure 3. These matrices require 20 values at the minimum which, of course, does not improve the statistical utility of the small sample.

Using these matrices as a starting point, both the descriptive statistical analysis and the detailed statistical analyses were performed. The descriptive statistical work discussed in this section included the simple computation of the level of non-zero response and preparation of index numbers for each of the questions. Using the results of these computations as a guide, the phraseology of each statement was reviewed to determine characteristics that questions have in common, and then questions having common characteristics were grouped into sub-sets or clusters. The computations that resulted from these matrices are given in Table 1, Appendix B. Table 2 in Appendix C lists those questions that were found to be the most important<sup>5</sup> from

5. Importance & important are words used to separate questions of some significance. These words are used instead of the word "significance" which implies statistical validity determined using specific techniques. For many reasons these techniques could not be used, with the result that statistical significance could generally not be determined. However, since a special methodology was used, a separate term was needed to identify the results of this methodology. Importance is the term.

one point of view or another. In all of the subsequent discussion, these two tables are used as points of reference.

The first measure of importance in connection with the 614 task statements analyzed is the level of non-zero responses. The criterion was arbitrarily set that an important response was one that had a 25% or greater non-zero response. This level was chosen because 25% of the total possible responses allowed for approximately five entries per square in the 2 x 2 matrix shown in Figure 3. Any fewer than this would have prevented the use of chi-square tests of independence. Even this small number of non-zero responses is not entirely satisfactory.

Four different index numbers were computed for the 614 items contained in the questionnaire. The first of these index numbers was computed as a basis for describing task statements as garrison or combat items measured in terms of the number of responses to each statement. This index number is computed by taking the row-column differences between combat/garrison responses, not including the zero response level, and dividing the differences by the sum of the significant garrison and combat responses.

This index is open to a wide range of interpretation. Two interpretations were considered in this analysis. The first involved identifying those questions that describe combat tasks and those that relate to garrison activities.

In task statements where the garrison/combat index is a small number, there is a reasonable probability that Marines in the sample would have responded to that statement in spite of whether they had been in garrison or combat. The second interpretation is that when the garrison/combat index number is high, there was probably little opportunity for the question to be interpreted as other than primarily a garrison task or primarily a task performed in combat. This index makes it possible to isolate those statements of principal concern, i.e. those describing what Marines remembered having done in combat.

The difficulty with this index number and with all index numbers is that the level of significance is difficult to determine. In this case the level of significance was measured from the mean value, which is shown in Table 1, Appendix B, for the garrison and combat index. Where an individual index number exceeded that mean value then the task associated with that question is assumed to be primarily or exclusively a garrison or a combat task.

The second index number that was computed is referred to as a homogeneity index. This index number reflects the relative frequency of the occurrence of entries on the matrix diagonal running from the zero/zero intersection to the 7/7 intersection of the matrix. Diagrammatically, this diagonal is shown in Figure 3. The homogeneity index was computed

as a simple measure of the extent to which respondents consistently or homogeneously interpreted questions at all levels of response possible. The interpretation of this index is that if the index number is high, then the task statement is fairly consistent in eliciting responses at all levels from individuals in spite of their combat or their garrison experience.

The third index computed for the 614 questions is referred to as an intensity index. The intensity index is a measure of the relative frequency of occurrence of responses for both garrison and combat at the 4, 5, 6, and 7 level. Responses at this level define a segment of the matrix that is shown in Figure 3 on p. 46, and is in the lower right-hand quadrant of the matrix. This index number can be interpreted as a measure of the intensity of response to a specific task. The intensity of response is also taken in terms of both garrison and combat duty for all respondents. Thus an index number that is large suggests that personnel responding to this task statement performed the task under any circumstances a large percentage of the time by their own interpretation. In some respects this segment of the matrix is more important than the segment of the matrix that would lie upon the diagonal measured by the homogeneity index.

The fourth index is an overall measure of the importance of a specific question from the point of view of all pre-

ceding measures. In other words, this measure is a composite of the number of non-zero responses, the garrison/combat index, the homogeneity index, and the intensity index.

Based upon the indices described above, all task statements in the questionnaire were classified by identifying those that were "important" and those that were not important. The important statements were then regrouped in terms of question phrasing. This review consisted of attempting to isolate two dimensions of each task statement. The first dimension involved the commonality of phraseology of statements that had similar levels as measured by at least one of the four indices. The second aspect reviewed was whether the terms used in the statements were specific or general in reference. It was assumed that statements that are concrete in reference are more likely to receive higher levels of response and ratings of importance than those that are more general in nature.

As a final step in the analysis, the table of indices was used as a basis for clustering task statements where the measures for individual statements were similar. This provided a means for identifying items which were not only similar in terms of quantitative measures, but reflected similarities in terms of the phrases and words used.

## 2. Discussion of descriptive analysis.

### a. Level of Response

The level of non-zero responses to the 614 questions contained in the questionnaire is shown in Table 1 in Appendix B. There were 304 questions out of the 614, or about 50%, to which Marines responded more than 25% of the time. If there is some significance\* in the fact that one would expect at least half of the 116 respondents to be non-zero on these individual tasks, then there were only 94 questions out of the 614 to which more than 50% of the officers responded. Based on a 50% level of response there are 94 statements which are of importance out of the 614 asked. Thus, there are between 94 and 304 task statements out of 614 which were important to the population of respondents.

### b. Garrison/Combat index.

Based on this index there were 42 more task statements, out of the 304, that were primarily garrison than the total number of combat items. Specifically, 168 or 55% of 304 statements were primarily garrison, 126 (41%) were combat and 10 (3%) had index values of "0". A "0" index value means that the task statement could apply equally to combat or garrison. A review of the ten items with index values of "0" did not reveal anything of significance to us in terms of consistency

---

\* Used in a non-statistical sense.

of language, etc. Since there may be some significance to the OMU staff, the ten tasks are listed below.

Task Statement  
Number

- 9. Supervise maintenance of embarkation records/containers/ supplies.
- 10. Maintain unit embarkation records/containers/ supplies.
- 84. Advise units on NBC defense training.
- 113. Provide input to IROL.
- 245. Determine effect of enemy's capabilities upon the mission of the command.
- 283. Provide for contingency plans.
- 484. Assign projects to reserve personnel.
- 490. Determine distribution of documents/materials.
- 493. Solicit intelligence information from other agencies.
- 527. Advise on SI matters.

Thus if one is looking for a set of task statements that would tend to measure what personnel actually do under combat conditions, there are only 126 items that would provide for that sort of definition. In addition, where the index number for garrison items was not very high, i.e. not above the mean value of 0.28 those task statements may also possess some characteristics useful in discriminating between what personnel do in

garrison and combat. Thus, potentially there are 204 (78 + 126) questions out of the 614 task statements that possess some significance in terms of being able to discriminate on the basis of those tasks that are primarily combat in nature.

c. Homogeneity index.

Based on the homogeneity index there are 28 items that are of importance. These task statements are important in the sense that the officers responding to them did so in a consistent fashion in spite of personal experience in combat or garrison. Thus the statements would be useful as tools to elicit consistent responses from Marines in spite of contingency experience, or perhaps, item phrasing. The consistency of response is also a good indicator of the amount of information to be obtained from the responses.

All of the items are characterized by low homogeneity index values in virtually every case. This index can also be interpreted as a percentage. Looked at in this way there are very few of the 28 possibly important task statements that have more than 20% of the usable non-zero responses lying on the diagonal. Applying standard statistical measures to numbers this small could lead to difficulties in interpretation.

The 28 task statements appear to fall into groups based upon similar values for adjacent items. One

group of statements dealt with MAGIS and management of classified material. A second group covered the topics of contingency planning and target information. The third group involved items about intelligence briefings.

d. Intensity index.

The intensity index is a measure of the strength of the response for all of those values of four or greater in the seven point response scale. Once again as with the homogeneity index, this number can be interpreted as a percentage. Viewed in this way there are few questions in which the level of response was 20% or greater. These task statements also suffer from all the problems of applying standard statistical tools to small numbers. Thirty-eight have an intensity index that is larger than 0.20, and 103 an index larger than 0.10. These statements also generally have high homogeneity index values.

e. Importance index.

This index was computed to identify those task statements that have some importance from the point of view of any of the above elementary statistical measures. The importance index for all of the 304 statements are listed in Table 3 in Appendix D. It remains to be determined whether any of these questions possess a "significant" enough amount of importance to be

considered as tools to discriminate between what Marine Corps personnel do in combat and what they do under garrison conditions.

C. Analysis of Significance

1. Chi Squared Evaluation

$\chi^2$  values were calculated for all 614 matrices resulting from the questionnaire data. These values are shown, for the most significant questions, in Table 4, Appendix F. The Hewlett-Packard program used to calculate these values is based on the equation:

$$\chi^2 = \sum_{i=1}^n \frac{(O_i - E_i)^2}{E_i}$$

where  $O_i$  = observed frequency, and  $E_i$  = expected frequency. Other algorithms were used, such as Bartlett's exact chi squared, in an effort to determine the one that would be most precise. Values resulting from these different algorithms were similar.

The need to explore alternative computation methods was dictated by the small matrix values, i.e. the number of non-zero responses. Small values often result in exaggerated  $\chi^2$ 's whose meaning is difficult to evaluate. This was especially true of  $\chi^2$  values such as 206.47 for question 354. When the  $\chi^2$  and index values for questions 354, 285, and 286 are evaluated, the conclusion should be that a value as large as 206.47 is spurious and probably

does not reflect a commensurately large significance.

Based on the values shown in Table 4 there are 57 questions with a significant  $X^2$  and 346 with highly significant  $X^2$ 's. Among the 211 task statements omitted from Table 4, many do not have significant  $X^2$ 's because of 0 values in the collapsed matrix yielding very low  $X^2$ 's or none at all. Consequently, one may say that there were significant data for approximately 2/3's of the OF 02 task statements. There are two tentative conclusions that may be drawn from this table of  $X^2$  values.

- There are 403 statements for which the data are significantly different than one would expect from chance. While this conclusion does not have operational value in terms of OMU's mission, it does support the opportunity for additional statistical analysis on these questions. Had the available computer resources been adequate, these 403 questions would have been analyzed to determine underlying clusters or factors.
- Since the  $X^2$  values were computed for both the garrison and combat parameters of each task statement, one may conclude that there is a high degree of interdependence between the combat and garrison aspects of each task as reflected in the OF 02 items. This could mean, for this group of

officers, that the task statements provide a reasonable measure of what a Marine does in combat by comparison with garrison duty.

Whether this conclusion is warranted would depend upon other factors such as nature and extent of combat experience, specialized training received, commissioned grade, etc.<sup>6</sup>

2. Clusters Based on  $X^2$  and Indices.

When the set of  $X^2$  values is superimposed on the index values, a cluster of the most important task statements was obtained. These task statements are listed in Table 2, Appendix C. These statements are regarded as the most important of all the 614 items in the OF 02 task inventory. If one were to choose a minimum set of questions that could supply the maximum amount of information (a desirable research goal) it would be those shown in Table 2, Appendix C. The notes provided below are based on this set.

- There are 97 most important statements out of 614 in the questionnaire.
- Eighty-four of the statements have highly significant  $X^2$ .
- The mean value of the intensity index for these 97 items is twice as large (0.1882 vs 0.0984) as the mean value for the 304 questions. In other words these tasks were very frequently performed,

---

6. See Appendix E for a summary of combat experience characteristics of this group of officers.

or the memory, correct or incorrect, of frequent performance is very strong.

- The mean value of the homogeneity index for these 97 task statements is twice (0.1645 vs. 0.0877) as large as the mean value for the 304 statements. In other words there was a consistent, i.e. interdependent response, on the questions between combat and garrison experience.
- Using the garrison/combat index there were roughly the same number of statements that were primarily garrison as were primarily combat (53 vs. 44). However, the mean value of this index for the 97 was less than for the 304 questions, and significantly so for the garrison questions (0.1946 vs. 0.2902). In other words the task statements tended to be more oriented to combat than the population of items at large.
- Fifty of the 97 task statements begin with verbs such as "supervise", "recommend", "coordinate", "assign", "advise", etc. While these are verbs one would presumably associate with an officer's area of responsibility, they are also words that impart a more general meaning to the phrases that follow them than words such as "plot", or "issue".

- Among the 97 most important task statements are a number of subsets of statements that have much in common. There are eleven such subsets or categories plus one "miscellaneous" category. These are the categories of tasks which are the most important of the 614 tasks covered in the questionnaire, and are those that possess importance as garrison or combat tasks. In other words, these are the categories of tasks that Marines apparently perform in combat.

The eleven categories are limited in that the statements contained in them do not cover all of the tasks in each category, and the categories themselves do not represent an exhaustive list. The important task categories are (item numbers in parenthesis);

- Supplies management (2, 3, 4, 5)
- Equipment management (5, 38, 41, 59, 50)
- Counterintelligence (189, 191, 192, 193, 194)
- Debriefings/briefs/reports (128, 196, 197, 474, 475, 476, 477, 480, 586, 222)
- Maps (198, 209, 211, 212, 213, 123, 572, 199)
- Electronic warfare (228, 229, 230)

- Records/documents management (233, 234, 235, 236, 258, 259, 261, 262, 364, 397, 490)
- Battle operations (231, 252, 305)
- Personnel (292, 399, 418, 419, 420, 484, 548, 485, 310)
- Security (162, 174, 183, 156, 377)
- Intelligence data collection (577, 594, 502, 493, 237, 239, 285, 286, 259, 253, 235, 179, 159, 154, 422, 430, 238)

The above categories only suggest what Marines actually do in combat and do not specifically describe performance under contingency conditions. Nonetheless, even this suggestion of the importance of these task areas should be useful to the planning of training and organization. Some objective measure would be required to ascertain conclusively that these are tasks Marines actually do perform in combat. The only way to obtain these data objectively would be through actual observation of tasks under battle conditions.

## CONCLUSIONS &amp; RECOMMENDATIONS

● Conclusions

- A. Task analysis must concern itself with both man-ascendant and machine-ascendant tasks. It must evaluate the high degree of interrelationship that exists between men and machines in terms of the contingency environment. In this setting it is less difficult to evaluate the variations of performance in which machine tasks are ascendant, than those situations in which man-ascendant tasks are of great importance. The OF 02 questionnaire heavily emphasizes man-ascendant tasks thereby not collecting task information concerning one large aspect of the contemporary combat environment. The reason for this emphasis may be that intelligence is not as high an equipment intensive field as others.
- B. There are a number of methodologies or techniques that can be used as tools to do task analysis. The most convenient and least expensive of these tools are questionnaires or personal interviews (such as conducted by Stouffer). However, these tools are not as precise as combat simulation, or observation of live combat.
- C. Using task analysis tools that rely on memory of performance introduces a number of chances for error. It is difficult at best to put boundaries on responses from memory without the aid of some objective measure. For example, Stouffer asked many subjective, memory questions, but designed

analysis of these questions around objective measures such as casualty rate. Absence of such objective measures could make even the most sophisticated analysis of doubtful utility.

- D. Question phrasing and terminology are critically important. Success in using questionnaires depends upon textual context, and questionnaire items should be prepared only by experienced personnel. Task statement selection and phrasing is considered especially critical in development of inventories to evaluate what Marines do under combat conditions.
- E. There are fewer important task statements than the 614 in the OF 02 questionnaire. There may be as few as 97 (based on  $X^2$  and index numbers) or as many as 402 (based on  $X^2$  only). It may be concluded that it was unnecessary to have as many as 614 items. This is especially true in view of the smaller number of experimental points (220 respondents with all combinations of experiences or 116 respondents with combat and garrison experience). From a statistical point of view, a more useful number of task statements would have been between 200 and 350. However, we do not know how a set of decision rules could have been established to ensure in advance that a smaller number of items would include all important contingency tasks.
- F. There is some difficulty with the sample of respondents. First, the sample of 116 is small enough to introduce a high

probability of sampling error. Second, 116 is a small population on which reliably to develop statistical analysis with substantial meaning to the issue of combat tasks. Third, the sample should have been much larger to compensate for all of the zero level, and therefore not useful, responses. For example, there were only 304 questions with a non-zero response level of 25 percent or more for the 116 respondents.

- G. Based upon the garrison/combat index the questionnaire tasks were more heavily oriented to garrison duty than to combat. It would have been more desirable to have more statements emphasize combat if the primary subject to be analyzed were performance under contingency conditions. For example, the Air Defense Command analyzed combat performance using few peacetime tasks and many more combat, or alert condition, tasks.
- H. The homogeneity index for the 304 tasks with 25% or more non-zero response was very low. This indicates that responses in the task statement matrices are diffuse, and because of the small sample, sparse.
- I. There were 57 task statements that have a significant and 346 with a highly significant chi square, or 403 statements that have some significance.
- J. The overlap between the chi square significant statements and the index significant items designated 97 task statements

as the most important of the 614 items in the inventory. This most important group of 97 task statements falls into 13 subject or task area clusters. These statements for the most part are oriented to combat responsibilities. They appear to be the most useful in determining what a Marine actually does in combat.

- K. The 97 most important task statements for determining what a Marine actually does in combat are not exhaustive. For example, they only lightly cover combat operations and instead, concentrate on such areas as planning and data collection. In addition, there are few task statements that cover truly contingent conditions. It might be asked, "How often has the book said do A under these circumstances". But, the dramatically different conditions of combat find Marines doing B, C, or D which perhaps are not even in the book. The questionnaire need not be "exhaustive" of combat tasks, but it should be representative to the fullest extent possible.
- L. The statistical analysis of the OF 02 questionnaire in this project was not intensive. An intensive analysis should be conducted using such tools as factor analysis and cluster analysis, and personnel data such as education, time in grade, MOS, and similar items. These should be analyzed in relation to response data. While some modifications could be made to OMU's experimental task analysis procedures, for

contingency studies, no major changes should be made until completion of an intensive analysis. Results of more thorough analysis could suggest the procedures to be used by OMU in its analysis of tasks performed under contingency conditions (by Marines in OF 02).

- M. There is a large volume of literature concerning scaling of item responses. None of the literature appears to be conclusive for the needs of OMU. However, it is considered that a seven point response scale is unnecessary. The present study addressed the question of scaling only indirectly. However, for the purposes of this study, a five point scale would have been completely adequate and more convenient for the matrices produced.

● Recommendations

- A. The use of questionnaires for task analysis of other combat occupational fields must be different than the OF 02 in a number of ways. The following are recommended changes.
1. The questionnaires must include more task statements that emphasize use of equipments.
  2. Although the length of the questionnaire will vary between OF's, it would be desirable that more effort be given to using short questionnaires.
  3. The questionnaires must be more equally balanced between the number of garrison and combat tasks. If it is possible to make a choice, there should be more combat

than garrison task statements.

4. Sound principles of experimental design should be followed to select a sample population that possesses a representative experience. This means that the population should be sufficiently large to permit generalization to the universe of combat experience, and the population should represent a cross section of combat experience.
  5. Since responses to task statements rely upon memory of combat, it will be required that some objective measures of combat performance be utilized in statistical analysis of results. Age, MOS, pay grade and length of service, are, of course, not measures of performance.
  6. It would be desirable to have less than the seven levels of response used on the OF 02 questionnaire.
- B. It is recommended that more intensive statistical analyses be performed on OF 02 results. These should include factor analysis and cluster analysis to isolate task sets as a function of combat and garrison duties. In addition, cross correlations would be required to determine the influence of factors such as age, education, MOS, etc.
- C. The task analysis questionnaire should be constructed on the basis of explicit hypotheses that OMU would like tested in the study of contingency tasks. If this were done, there is a greater likelihood that the correct data would be collected.

D. It is recommended that OMU obtain more information, in detail, about alternative task analysis methods. It is believed probable that a cost-benefit analysis would lead to questionnaires similar to the present format. It is also likely that such studies could lead to new insights into the most appropriate methodologies for OMU's task analysis of duties performed by Marines under combat conditions.

## BIBLIOGRAPHY

Brown, Frank L. and Jacobs, T.O., DEVELOPING THE CRITICAL COMBAT PERFORMANCE REQUIRED OF THE INFANTRY RIFLE PLATOON LEADER, Human Resources Research Organization, Alexandria, Virginia: April 1970.

Brown, Frank L., CRITICAL COMBAT PERFORMANCES, KNOWLEDGES, SKILLS REQUIRED OF THE INFANTRY RIFLE PLATOON LEADER, Human Resources Research Organization, Washington, D.C.: July 6, 1966.

COMBAT ACTIONS IN KOREA, Department of Defense, 1973, 720 pages.

DESIGN OF COURSES OF INSTRUCTION, U.S. Marine Corps, MCOP 1510-23A, November 7, 1972.

Helme, W.H., Willemin, L.P. and Grafton, F.C., Prediction of Officer Behavior in A Simulated Combat Situation, CATALOG OF SELECTED DOCUMENTS IN PSYCHOLOGY, 1975, Vol. 5, pp. 212-213.

Marshall, S.L.A., PORK CHOP HILL, New York: William Morrow & Co., 1956.

Stouffer, Samuel A., Lumdaine, Arthur A., and Williams, Robin M., THE AMERICAN SOLDIER: COMBAT & ITS AFTERMATH, Princeton University Press, 1949.

Whitemore, Paul G., USE OF THE JOB MODEL CONCEPT TO GUIDE JOB DESCRIPTIONS FOR ARMY OFFICERS, Human Resources Research Organization, Alexandria, Virginia, November, 1973. (Technical Report No. 73.26)

APPENDIX A

MATRICES FOR 10 TASK STATEMENTS  
SELECTED AS REPRESENTATIVE OF THE 97  
MOST IMPORTANT TASK STATEMENTS  
IN THE OF 02 TASK INVENTORY

QUESTION # 41

	IN COMBAT									TOTAL
	0	1	2	3	4	5	6	7		
0	39	2	2	0	1	3	2	1	50	
1	2	1	0	0	1	1	0	0	5	
2	0	0	1	1	0	0	0	0	2	
3	1	0	1	0	1	1	0	0	4	
IN GARRISON										
4	7	2	1	0	7	1	0	1	19	
5	5	0	2	3	2	0	0	1	13	
6	4	1	0	0	2	0	0	0	7	
7	4	0	1	0	2	1	2	6	16	
TOTAL	62	6	8	4	16	7	4	9	116	

QUESTION # 97

	IN COMBAT									TOTAL
	0	1	2	3	4	5	6	7		
0	56	0	1	0	4	0	3	0	64	
1	0	1	0	1	1	0	2	0	5	
2	0	0	0	0	0	0	0	0	0	
3	2	0	0	0	1	0	0	0	3	
IN GARRISON										
4	5	1	0	0	13	3	0	0	22	
5	2	0	0	0	1	0	2	0	5	
6	1	0	0	0	0	1	2	0	4	
7	1	0	0	0	0	0	0	12	13	
TOTAL	67	2	1	1	20	4	9	12	116	

QUESTION # 115

		IN COMBAT.								TOTAL
		0	1	2	3	4	5	6	7	
IN GARRISON	0	66	5	2	2	5	0	3	6	89
	1	0	0	1	1	2	1	0	0	5
	2	2	0	1	1	1	0	0	0	5
	3	1	0	0	0	0	0	1	0	2
	4	1	0	0	0	3	1	0	3	8
	5	0	0	0	0	0	0	1	0	1
	6	0	0	0	0	0	0	2	1	3
	7	0	0	0	0	0	1	1	1	3
TOTAL		70	5	4	4	11	3	8	11	116

QUESTION # 122

		IN COMBAT								TOTAL
		0	1	2	3	4	5	6	7	
IN GARRISON	0	56	5	0	2	8	3	9	6	89
	1	1	3	1	0	0	0	0	1	6
	2	0	0	0	0	2	0	0	0	2
	3	1	0	0	1	1	0	0	0	3
	4	3	0	0	0	5	0	1	1	10
	5	1	0	0	0	0	0	0	0	1
	6	2	0	0	0	1	1	0	0	4
	7	0	1	0	0	0	0	0	0	1
TOTAL		64	9	1	3	17	4	10	8	116

QUESTION # 148

73

	IN COMBAT									TOTAL
	0	1	2	3	4	5	6	7		
0	62	1	0	1	2	0	0	0	66	
1	6	2	1	0	2	0	0	0	11	
2	4	0	1	0	1	0	0	0	6	
3	2	0	0	0	0	0	0	0	2	
IN GARRISON										
4	10	1	1	0	7	0	1	0	20	
5	2	0	0	0	0	0	1	0	3	
6	1	0	0	0	2	1	1	0	5	
7	1	1	1	0	0	0	0	0	3	
TOTAL	88	5	4	1	14	1	3	0	116	

QUESTION # 189

	IN COMBAT									TOTAL
	0	1	2	3	4	5	6	7		
0	42	3	2	1	6	2	4	1	61	
1	3	3	1	1	1	0	0	1	10	
2	0	0	2	0	2	0	1	1	6	
3	0	0	0	2	1	0	0	0	3	
IN GARRISON										
4	4	0	0	1	12	1	2	0	20	
5	0	0	0	1	0	2	1	0	4	
6	3	0	0	0	1	0	1	0	5	
7	1	1	0	0	1	0	0	4	7	
TOTAL	53	7	5	6	24	5	9	7	116	

QUESTION # 209

74

	IN COMBAT									TOTAL
	0	1	2	3	4	5	6	7		
0	58	0	1	0	4	2	2	7	74	
1	1	0	0	1	1	1	1	0	5	
2	1	0	0	0	0	0	1	0	2	
3	1	0	0	0	0	0	0	0	1	
IN GARRISON 4	3	0	0	1	5	0	2	2	13	
5	1	0	1	0	0	0	0	1	3	
6	4	1	0	0	1	0	1	1	8	
7	3	0	0	0	1	0	1	5	10	
TOTAL	72	1	2	2	12	3	8	16	116	

QUESTION # 212

	IN COMBAT									TOTAL
	0	1	2	3	4	5	6	7		
0	45	1	3	0	6	2	1	7	65	
1	1	0	1	0	0	1	0	1	4	
2	0	0	0	0	0	0	0	1	1	
3	1	0	0	0	0	0	0	0	1	
IN GARRISON 4	8	0	1	0	11	1	1	3	25	
5	1	0	0	0	1	2	0	0	4	
6	1	0	1	0	1	0	2	1	6	
7	1	0	0	0	0	1	0	8	10	
TOTAL	58	1	6	0	19	7	4	21	116	

QUESTION # 233

	IN COMBAT									TOTAL
	0	1	2	3	4	5	6	7		
0	63	1	0	0	5	1	0	0	70	
1	3	1	0	0	0	0	0	0	4	
2	0	1	2	0	3	1	0	0	7	
3	1	0	0	0	0	0	0	0	1	
IN GARRISON 4	10	4	0	0	9	0	0	0	23	
5	1	0	0	0	0	0	0	0	1	
6	1	0	0	0	4	1	2	0	8	
7	1	1	0	0	0	0	0	0	2	
TOTAL	80	8	2	0	21	3	2	0	116	

QUESTION # 252

	IN COMBAT									TOTAL
	0	1	2	3	4	5	6	7		
0	44	1	1	4	16	2	5	7	80	
1	2	1	0	0	5	0	1	1	10	
2	0	0	0	0	0	0	2	0	2	
3	0	0	0	0	1	0	0	0	1	
IN GARRISON 4	2	0	1	0	3	0	3	2	11	
5	0	0	0	0	0	1	0	0	1	
6	1	0	0	0	1	0	0	2	4	
7	1	0	0	0	1	0	1	4	7	
TOTAL	50	2	2	4	27	3	12	16	116	

APPENDIX B

NON-ZERO RESPONSES AND VALUES  
OF THE FOUR INDICES FOR "IMPORTANT"  
TASK STATEMENTS IN THE OF 02 TASK  
ANALYSIS QUESTIONNAIRE

TABLE 1  
 Non-zero Responses and Values of The  
 Four Indices for "Important" Task Statements  
 in The OF O2 Task Inventory

Question Number	No. of Non- "0" Responses	Garrison/Combat Index		Homogeneity Index	Intensity Index
		Combat	Garrison		
1	43		.05	.09	0
2	52	.30		.07	.03
3	62	.23		.07	.05
4	57	.05		.05	.07
5	52	.27		.08	.04
6	43		.25	.05	.00
9	34			.07	.03
10	39			.05	.01
11	42	.11		.04	.03
12	41		.05	.03	.01
13	41	.13		.03	.02
16	36	.05		.09	.03
19	35	.04		.07	.03
20	34	.12		.07	.02
21	33		.18	.10	.05
23	40		.45	.08	.03
25	39	.08		.07	.03
26	45		.03	.05	.03
27	41		.23	.06	.03
29	34		.28	.07	.03
32	48	.08		.16	.16
33	29	.14		.12	.09
37	41		.11	.08	.08
38	55		.02	.15	.17
39	29		.27	.08	.03
41	77		.10	.13	.22
46	68		.48	.04	.04
48	40		.37	.03	.02
49	59		.33	.08	.13
50	66		.22	.10	.14
53	38		.52	.03	.02
54	68		.44	.04	.05
56	43		.54	.02	.03
57	29		.56	.01	.01
58	35		.81	.02	.02
59	45		.46	.04	.02
60	39		.39	.03	.01
61	43		.41	.04	.01
63	38		.42	.02	0
64	40		.52	.03	.01
65	76		.70	.03	.02
66	45		.69	.01	0
75	29		.56	.01	0
76	46		.52	.01	.03
77	31		.62	.02	.02
78	57		.70	.02	.01
79	38		.80	.02	0
80	31		.68	.03	0

Question Number	No. of Non- "0" Responses	Garrison/Combat Index		Homogeneity Index	Intensity Index
		Combat	Garrison		
84	29			.03	.03
89	37	.13		.08	.09
94	30	.02		.06	.03
97	60		.03	.24	.29
98	41		.11	.08	.09
99	40	.28		.09	.07
100	36	.36		.04	.05
102	50	.29		.06	.13
103	59	.44		.04	.08
104	41	.25		.05	.08
112	33	.23		.04	.04
113	32			.06	.05
115	50	.26		.06	.12
116	63	.30		.14	.20
117	39	.09		.12	.09
118	29		.06	.07	.07
119	59	.07		.17	.22
120	54	.05		.18	.21
122	60	.45		.08	.08
123	65	.22		.07	.14
124	45		.17	.03	.08
125	33		.12	.07	.06
126	30		.16	.04	.05
128	63		.32	.09	.10
130	34		.25	.05	.05
134	35		.36	.04	.05
140	44	.69		.01	.03
141	58	.67		.02	.02
142	39	.62		.01	.02
143	31	.28		.03	.01
144	32	.35		.03	.03
146	30		.25	.04	.01
148	54		.28	.09	.11
149	47		.31	.09	.09
152	32		.56	.03	.01
153	50		.51	.03	.03
154	55		.37	.05	.05
155	60		.37	.04	.05
156	67		.36	.05	.09
157	34		.32	.05	.03
158	42		.25	.06	.06
159	66		.32	.13	.16
162	59		.25	.10	.14
163	66		.33	.10	.15
165	43	.31		.03	.04
166	39	.32		.04	.04
167	50	.33		.04	.08
168	40	.37		.03	.03
170	37	.59		.03	.05
174	57		.26	.13	.10
177	39		.18	.12	.08
179	50		.12	.15	.19
180	30		.18	.08	.03
181	33		.15	.11	.08
182	34		.14	.11	.08

Question Number	No. of Non-"0" Responses	Garrison/Combat Index		Homogeneity Index	Intensity Index
		Combat	Garrison		
183	92	.04		.22	.41
184	33	.17		.04	.08
185	45	.32		.04	.04
186	72	.22		.06	.11
187	58	.28		.06	.08
188	49	.09		.14	.14
189	74	.07		.22	.22
190	40	.06		.09	.09
191	60	.17		.10	.13
192	59	.18		.13	.19
193	70	.27		.12	.16
194	76	.22		.14	.22
195	46	.17		.09	.11
196	56	.20		.12	.14
197	64	.48		.05	.09
198	83	.41		.11	.13
199	81	.23		.07	.07
206	45	.30		.03	.05
207	49	.37		.04	.07
209	58	.02		.09	.17
210	66	.02		.11	.18
211	60	.07		.12	.22
212	71	.06		.20	.28
213	68	.27		.11	.18
214	37	.32		.06	.07
218	33	.12		.08	.08
222	55	.28		.08	.15
223	66	.26		.09	.16
224	42	.13		.07	.07
225	57	.13		.09	.12
226	34	.16		.06	.06
227	47	.09		.08	.09
228	85	.34		.12	.18
229	90	.26		.10	.23
230	54	.33		.04	.09
231	51	.31		.04	.10
232	45	.33		.04	.09
233	53		.12	.12	.14
234	66		.06	.10	.17
235	78	.33		.08	.18
236	68	.41		.09	.11
237	75	.39		.11	.12
238	77	.39		.11	.15
239	64	.38		.05	.10
240	44	.57		.03	.02
244	30		.10	.03	.03
245	32			.03	.03
246	30		.16	.02	.02
247	39		.06	.02	.01
248	44	.43		.02	.05
250	31	.13		.03	.03
252	72	.31		.08	.16
253	58	.33		.09	.14
259	60	.51		.05	.07
260	38	.25		.04	.05
261	31	.14		.04	.03

Question Number	No. of Non- "0" Responses	Garrison/Combat Index		Homogeneity Index	Intensity Index
		Combat	Garrison		
263	35	.35		.03	.03
264	30	.30		.01	.03
265	32	.37		.05	.03
267	37	.40		.03	.03
273	45		.13	.08	.09
275	42		.15	.08	.08
279	31		.42	.06	.01
281	32		.51	.04	.02
283	85			.35	.35
285	102		.08	.45	.45
286	114		.09	.55	.58
288	45		.21	.10	.08
289	41		.63	.04	.03
290	97		.38	.14	.08
291	48		.37	.11	.11
292	65		.30	.06	.10
296	34		.24	.06	.03
299	33		.14	.09	.05
301	37		.39	.03	.02
305	64		.09	.09	.16
308	38		.53	.03	.03
310	71		.34	.12	.11
315	102		.24	.34	.42
351	75		.12	.19	.20
352	87		.06	.31	.24
353	49		.04	.12	.12
354	76		.11	.24	.20
355	60		.01	.14	.08
356	76		.05	.23	.19
357	37	.07		.12	.04
358	74		.09	.27	.18
359	84		.12	.30	.27
360	35		.13	.09	.11
361	68		.17	.22	.22
362	59		.33	.15	.12
363	32		.14	.09	.07
364	50		.11	.15	.14
365	39		.19	.11	.10
367	42		.32	.11	.08
368	42		.27	.06	.05
369	38		.14	.03	.08
371	33		.35	.07	.03
377	61		.51	.07	.07
388	48		.50	.04	.03
390	41		.59	.03	.03
392	33		.30	.06	.07
397	89		.07	.37	.41
398	45		.08	.20	.19
399	84		.10	.36	.41
403	32		.74	.05	.03
405	35		.45	.03	.03
409	32	.49		.04	.03
412	45	.70		.07	.03
413	54		.55	.08	.04
414	44		.45	.09	.06

Question Number	No. of Non-"0" Responses	Garrison/Combat Index		Homogeneity Index	Intensity Index
		Combat	Garrison		
416	46		.41	.10	.06
417	29		.44	.03	.01
418	83		.27	.23	.32
419	63		.37	.10	.16
420	64		.35	.08	.12
422	65		.83	.03	.06
424	46		.11	.06	.10
429	29		.17	.05	.04
430	60		.28	.13	.18
431	36		.22	.06	.06
437	37		.19	.06	.05
440	32		.38	.08	.07
441	32		.33	.06	.07
443	35		.25	.07	.09
444	48		.35	.09	.07
445	51		.28	.07	.07
448	37		.38	.06	.05
449	43		.41	.05	.03
450	33		.29	.09	.07
457	33		.59	.02	0
460	29		.28	.05	.03
461	36		.29	.06	.09
469	38		.55	.04	.03
470	32		.19	.08	.09
471	106		.05	.21	.42
472	32		.29	.06	.09
473	106		.02	.28	.42
474	81		.1	.18	.23
475	77		.13	.18	.29
476	81		.04	.23	.35
477	57		.20	.16	.19
478	52	.01		.12	.16
479	30	.10		.11	.13
480	88		.06	.43	.24
483	30		.89	0	0
484	73			.20	.30
485	54		.39	.08	.12
486	98		.04	.31	.24
487	60		.11	.19	.23
488	98		.28	.32	.43
490	86			.23	.35
491	45		.06	.11	.15
493	66			.16	.20
501	38		.02	.06	.11
502	59		.04	.20	.26
504	30	.27		.03	.02
513	33	.12		.08	.05
514	41	.07		.05	.04
516	57		.54	.04	.04
527	29			.06	.01
528	39	.18		.04	.03
532	41		.63	.03	.03
533	32		.62	.02	.01
537	39		.58	.03	.03
541	46	.07		.06	.06

Question Number	No. of Non-"0" Responses	Garrison/Combat Index		Homogeneity Index	Intensity Index
		Combat	Garrison		
545	46		.33	.03	.05
548	86		.42	.19	.25
559	36	.22		.05	.04
560	41		.19	.05	.04
561	65		.03	.03	.03
562	34	.14		.03	.04
563	54		.04	.04	.04
564	50	.01		.07	.05
565	38		.09	.03	.03
566	50	.10		.07	.09
567	52	.09		.06	.09
568	46	.10		.05	.08
569	43	.02		.04	.07
571	46	.17		.10	.08
572	86	.08		.25	.31
576	62	.21		.04	.10
577	53	.28		.07	.10
578	29	.18		.03	.04
579	34	.25		.04	.06
580	37	.12		.05	.07
583	45		.09	.07	.08
585	62	.16		.09	.17
586	47	.13		.05	.08
587	39	.08		.05	.08
589	51	.45		.03	.07
590	30		.20	.03	.04
594	59		.10	.11	.17
599	42		.28	.11	.03
600	46	.31		.02	.05
601	33	.41		.03	.02
604	30	.5		.03	.03
605	37	.48		.02	.03
606	48	.27		.03	.06
609	31	.49		.01	.03
610	31	.49		.02	.03
Mean	49.9	0.2479	0.2902	0.0877	0.0984
Number	304	126	168		

205 Have H.S.  $\chi^2$   
 33 Have S  $\chi^2$   
 66 Are Not Significant = 0  $\chi^2$

APPENDIX C

LIST OF MOST IMPORTANT TASK STATEMENTS

TABLE 2  
LIST OF MOST IMPORTANT TASK STATEMENTS

2. Supervise supply requisitioning
3. Issue intelligence related materials/supplies
4. Supervise the issuance of intelligence related materials/supplies
5. Develop life-cycle costing for materials/supplies/equipment
38. Plan equipment tests
41. Recommend equipment acquisition
49. Prepare equipment/vehicle maintenance requests
50. Supervise pickup/delivery of vehicles for maintenance
97. Review/edit IPIR/SUPIR
102. Coordinate photo support requirements
103. Monitor film quality
115. Determine potential targets from aerial photos
116. Compare aerial photos with planned coverage
119. Prepare/write legend for photos/imagery
120. Screen/orient film to identify specific area of interest
122. Supervise interpreters engaged in imagery analysis
  
148. Assign DAME requirements to CI Team
154. Conduct surveillances
  
159. Screen/review subversive material/publications
162. Coordinate bomb threat procedures
163. Monitor compliance with Defense Investigation Review Council (DIRC) directions and policies
174. Recommend procedures for correcting security deficiencies
179. Administer source/agent control
183. Supervise repair of locks
189. Advise subordinate units on CI matters
191. Send CI credentials to HQMC
192. Request CI credentials from HQMC
193. Evaluate intelligence information/developments
194. Assign collection requirements to CI Team(s)
196. Conduct debriefings
197. Supervise debriefing
198. Issue maps/charts
199. Determine map requirements
209. Check mission coverage plots
211. Transfer geo-coordinates and ID/BE numbers from DIA references to maps/graphics
212. Supervise the transfer of geo-coordinates and ID/BE numbers from DIA references to maps/graphics
213. Assign numbers (for local ID) to items plotted on map
222. Supervise dissemination distribution of intelligence related materials
223. Request photo missions
225. Assign photo missions
228. Conduct electronic warfare planning
229. Coordinate electronic warfare planning
230. Supervise electronic warfare planning
231. Plot order of battle
233. Maintain intelligence journal

234. Supervise the maintenance of the intelligence journal
235. Maintain intelligence workbook
236. Supervise the maintenance of the intelligence workbook
  
252. Review beach analysis
253. Plan area study projects
259. Supervise establishment of the intelligence center
283. Provide for contingency plans
285. Monitor foreign broadcasts
286. Determine research requirements
292. Write/review fitness reports
305. Erect/strike tents
310. Perform paratrooper jump (to maintain proficiency)
315. Participate in special study groups/committees
351. Monitor status of equipment in "II" segment of MAGIS
352. Check IPIR/SUPIR printouts
354. Develop equipment specification (MAGIS)
355. Coordinate MAGIS test training
356. Monitor MAGIS testing
358. Supervise inventory of classified material
359. Prepare classified material for destruction
361. Destroy classified material
362. Witness destruction of classified material
364. Authenticate record of destruction of classified material
377. Instruct travelers on security matters
397. Supervise inventory of assets
399. Supervise recreational activities
413. Supervise read board
418. Recommend T/O changes
419. Review T/E changes
420. Recommend T/E changes
422. Read professional publications/documents
430. Supervise maintenance of NIPS data library
471. Request applicant Screening Interview
474. Prepare briefs (oral and written)
475. Request briefs
476. Conduct briefs
477. Supervise preparation/conduction of brief
480. Recommend subject to be briefed
484. Assign projects to reserve personnel
485. Monitor projects assigned to reserve personnel
486. Conduct liaison with reserves
487. Conduct liaison with supported units
488. Conduct liaison with law enforcement agencies
490. Determine distribution of documents/materials
493. Solicit intelligence information from other agencies
502. Conduct vacated CP inspections
516. Take still photographs
548. Screen personnel for language training capability
  
572. Mount maps
577. Monitor activity of collection agency/agencies
586. Prepare intelligence estimate
594. Respond to inquiries/requests for intelligence products

APPENDIX D

IMPORTANCE INDEX VALUES FOR  
"IMPORTANT" TASK STATEMENTS  
IN THE OF 02 TASK INVENTORY

TABLE 3  
 IMPORTANCE INDEX VALUES FOR "IMPORTANT" TASK  
 STATEMENTS IN THE OF O2 TASK INVENTORY

<u>Question Number</u>	<u>Index of Importance</u>	<u>Question Number</u>	<u>Index of Importance</u>	<u>Question Number</u>	<u>Index of Importance</u>
1	.29	97	.40	182	.23
2	.35	98	.28	183	.62
3	.41	99	.27	184	.22
4	.38	100	.24	185	.30
5	.35	102	.34	186	.48
6	.29	103	.39	187	.39
9	.23	104	.27	188	.33
10	.26	112	.22	189	.50
11	.28	113	.21	190	.27
12	.27	115	.34	191	.40
13	.27	116	.42	192	.40
16	.24	117	.26	193	.47
19	.23	118	.19	194	.51
20	.23	119	.40	195	.31
21	.22	120	.36	196	.38
23	.27	122	.40	197	.43
25	.26	123	.44	198	.56
26	.30	124	.30	199	.54
27	.27	125	.22	206	.30
29	.23	126	.20	207	.33
32	.32	128	.42	209	.39
33	.20	130	.23	210	.44
37	.27	134	.23	211	.40
38	.37	140	.29	212	.48
39	.19	141	.39	213	.46
41	.52	142	.26	214	.25
46	.45	143	.21	218	.22
48	.27	144	.21	222	.37
49	.40	146	.20	223	.44
50	.44	148	.36	224	.28
53	.25	149	.32	225	.38
54	.45	152	.21	226	.23
56	.29	153	.33	227	.32
57	.19	154	.37	228	.57
58	.23	155	.40	229	.60
59	.30	156	.45	230	.36
60	.26	157	.23	231	.34
61	.29	158	.28	232	.30
63	.25	159	.44	233	.36
64	.27	162	.40	234	.44
65	.51	163	.44	235	.52
66	.30	165	.29	236	.46
75	.19	166	.26	237	.50
76	.31	167	.33	238	.52
77	.21	168	.27	239	.43
78	.38	170	.25	240	.29
79	.25	174	.38	244	.20
80	.21	177	.26	245	.21
84	.19	179	.34	246	.20
89	.25	180	.20	247	.26
94	.20	181	.20	248	.29

TABLE 3

<u>Question Number</u>	<u>Index of Importance</u>	<u>Question Number</u>	<u>Index of Importance</u>	<u>Question Number</u>	<u>Index of Importance</u>
250	.21	390	.27	490	.58
252	.48	392	.22	491	.30
253	.39	397	.60	493	.44
259	.40	398	.30	501	.25
260	.25	399	.57	502	.40
261	.21	403	.21	504	.20
263	.23	405	.23	513	.22
264	.20	409	.21	514	.27
265	.21	412	.30	516	.38
267	.25	413	.36	527	.19
273	.30	414	.29	528	.26
275	.28	416	.31	532	.27
279	.20	417	.19	533	.21
281	.21	418	.56	537	.26
283	.57	419	.42	541	.31
285	.69	420	.43	454	.31
286	.77	422	.43	548	.58
288	.30	424	.31	559	.24
289	.27	429	.19	560	.27
290	.65	430	.40	561	.43
291	.32	431	.24	562	.23
292	.44	437	.25	563	.36
296	.23	440	.21	564	.33
299	.22	441	.21	565	.25
301	.25	443	.23	566	.34
305	.43	444	.32	567	.35
308	.25	445	.34	568	.31
310	.48	448	.25	569	.29
315	.69	449	.29	571	.31
351	.50	450	.22	572	.58
352	.58	457	.22	576	.42
353	.33	460	.19	577	.36
354	.51	461	.24	578	.19
355	.40	469	.25	579	.23
356	.51	470	.21	580	.25
357	.25	471	.71	583	.30
358	.50	472	.21	585	.42
359	.56	473	.71	586	.31
360	.24	475	.54	587	.26
361	.46	476	.54	589	.34
362	.40	477	.38	590	.20
363	.21	478	.35	594	.40
364	.34	479	.20	599	.28
365	.26	480	.59	600	.31
367	.28	483	.20	601	.22
368	.28	484	.49	604	.20
369	.25	485	.36	605	.25
371	.22	486	.66	606	.32
377	.41	487	.40	609	.21
388	.32	488	.66	610	.21

APPENDIX E

REPRESENTATIVE CHARACTERISTICS OF  
OFFICERS IN THE OF 02 SAMPLE

AD-A032 663

CALIFORNIA STATE UNIV LOS ANGELES

F/6 5/9

PEACE-TIME TASK ANALYSIS AND ITS RELATION TO WAR-TIME CONDITION--ETC(U)

APR 76 P J HANSON, C H STONE

N00014-74-A-0436-001

UNCLASSIFIED

TR-12

NL

2 of 2  
AD  
A032663



END

DATE  
FILMED  
1-77

## APPENDIX B

REPRESENTATIVE CHARACTERISTICS OF  
OFFICERS IN THE OF 02 SAMPLE

Part II of the task analysis questionnaire provides background data concerning survey respondents. This background is useful in all cases but especially useful for contingency task analysis. Specifically, this section of the questionnaire supplies information concerning experience of intelligence officers in the combat environment. The information is supplied by way of responses to specific questions. This appendix provides a brief review of this information.

The questions of interest in Part II are numbers 37, 38, 39, 40, 55, 56, 57, 58, and 59. The number and percent response to each of these questions is provided for the 116 officers in the sample. In some cases the total response for a question may be less than 116. Any differences can be accounted for by "0's" or blanks on the computer tape used.

Perhaps the most important Part II questions concern the combat experience of questionnaire respondents.

55. Have you filled an OF 02 billet in a combat environment?

1. Yes	111	(96%)
2. No	5	(4%)
Total	116	100%

On the basis of question 55 there can be little doubt that virtually 100 percent of the officers had OF-02 combat experience. However, it is worth

inquiring about the extent of this experience. Questions 58 and 59 provide insights to this area.

58. If you filled an OF-02 billet in a combat environment, what was the length of time you held the billet? (If more than one billet was held indicate the one held for the longest period of time)

1. Not applicable	3	( 3%)
2. 1-3 months	1	(Neg)
3. 4-6 months	12	(10%)
4. 7-9 months	14	(12%)
5. 10-12 months	41	(35%)
6. 13-18 months	35	(30%)
7. 19-24 months	3	( 3%)
8. 25 or more months	7	( 7%)
Total	<u>116</u>	<u>100%</u>

59. What commissioned grade did you hold at the time you filled the billet indicated in question 58 above?

1. Not applicable	20	(17%)
2. Warrant Officer (WO-1 through CWO-4)	17	(15%)
3. Second Lieutenant	9	( 8%)
4. First Lieutenant	26	(22%)
5. Captain	27	(23%)
6. Major	14	(12%)
7. Lieutenant Colonel	2	( 2%)
8. Colonel	1	( 1%)
Total	<u>116</u>	<u>100%</u>

The responses to question 58 clearly indicate a distribution of experience skewed toward a large amount of time in OF-02 combat experience. Forty percent of the respondents have more than a year of such experience.

Based on question 59 one could conclude that, using grade as an indicator, the background of Marine Corps experience is also high. In this case 38 percent of the respondents held the rank of captain or higher. Questions not answered concerning length and intensity of experience are :

- o What was the nature of the combat experience?
- o In what kind of combat setting was the experience acquired?
- o How long ago was the experience acquired?

Partial answers to these questions may be obtained from questions 56 and 57. No interpretation of results to these questions is offered here because of the researchers unfamiliarity with detail of Marine Corps intelligence structure and operation. In any event responses to these questions are provided below for the readers benefit.

56. If you have filled an OF-02 billet in a combat environment, what was the billet MOS? (If more than one billet was held, select the one filled the longest period of time in combat)

1. Not applicable	5	( 4%)
2. MOS 0202	54	(47%)
3. MOS 0210	39	(34%)
4. MOS 0240	10	( 9%)
5. MOS 0250	8	( 6%)
Total	116	100%

57. If you filled an OF-02 billet in a combat environment, what title best describes the billet? (If more than one billet was held, indicate the one held for the longest period of time)

01. Not applicable	4	(3%)
02. Combat Intelligence Officer (Force level or above)	4	(3%)
03. Combat Intelligence Officer (Division/Wing level)	6	(5%)
04. Combat Intelligence Officer (Regiment/Group level)	13	(11%)
05. Combat Intelligence Officer (Battalion/Squadron level)	9	(8%)
06. Counterintelligence Officer (Staff level)	3	(3%)
07. Counterintelligence Officer (Unit level)	20	(17%)
08. Team Commander	11	(9%)
09. Order of Battle Officer	2	(2%)
10. Imagery-Interpretation Officer	7	(6%)
11. Special Security Officer	0	
12. Surveillance Officer	0	
13. Special Intelligence Officer/Analyst	5	(4%)
14. Intelligence Analyst	2	(2%)
15. Sensor Officer	0	
16. Estimates Officer	1	(Neg)
17. Support Officer	0	

18. Library Officer	0	
19. Intelligence Plans Officer	1	(Neg)
20. Special Warfare Officer	0	
21. Collection Officer	4	(3%)
22. Interrogator-Translator	5	(4%)
23. Production Officer	0	
24. Liaison Officer (Joint/Unified/Specified Command)	1	(Neg)
25. Naval Attache/Assistant Naval Attache	0	
26. Area Specialist	0	
27. Amphibious Intelligence Officer	0	
28. Intelligence Researcher	0	
29. Intelligence Advisor	8	(7%)
30. Other (Indicate on back cover)	10	(9%)
Total	116	100%

The only other Part II questions related to the subject of this research report concern exercises, CPX's, etc. Questions 37 to 40 are interesting in this connection.

37. Does your present assignment afford training (to include field exercises) in combat related skills?

1. Yes	65	(56%)
2. No	50	(44%)
Total	116	100%

38. Do exercises/CPX's/MAFLEX's alone satisfy the training requirement to maintain collection proficiency?

1. Yes	16	(14%)
2. No	85	(74%)
3. No Opinion	14	(12%)
Total	116	100%

39. How many field exercises/CPX's have you participated in during your current assignment?

1. None	47	(41%)
2. 1	23	(20%)
3. 2	22	(19%)
4. 3 or more	24	(20%)
Total	116	100%

40. Are the number of field exercises/CPX's adequate to maintain your skills for a combat situation?

1. Yes	39	(36%)
2. No	70	(64%)
Total	116	100%

Based on question 38, 74 percent of the officers believe that CPX's, etc., do not satisfy data collection proficiency training requirements. However, heavy emphasis should not be placed on this response in view of the fact that 61 percent of the officers have participated in one or fewer such exercises, and also, 64 percent also believe that the number of exercises is too few to maintain proficiency in combat skills.

Responses to these questions provide support, albeit light, for this research report in the following ways.

1. The questionnaire respondents are experienced in combat to some extent. If this experience is reflected in questionnaire responses, then there are very few OF-02 task statements (97) that possess significance to analysis of combat tasks. The responses for the remaining questions suggest that the other tasks in the questionnaire are not important in any case or more important in garrison. Ninety-seven questions with responses from 116 officers do not supply a great deal of information about the probable range of tasks in a modern combat environment.
2. Exercises do not appear to have wide use among intelligence officers for combat tasks. This lack of use may suggest a fertile area for review in support of training, and conceivably for use as a task analysis tool.

APPENDIX F

CHI SQUARE VALUES FOR 402  
TASK STATEMENTS WITH STATISTICALLY  
SIGNIFICANT  $\chi^2$

TABLE 4  
CHI SQUARE VALUES FOR 402 TASK STATEMENTS  
WITH STATISTICALLY SIGNIFICANT  $\chi^2$

Question #	Significant ( $\chi^2$ 3.84)	Highly Significant ( $\chi^2$ 6.64)	Question #	Significant ( $\chi^2$ 3.84)	Highly Significant ( $\chi^2$ 6.64)
2		6.72	98		22.44
3		8.21	99		12.68
4		16.30	100		15.51
5		10.39	102		24.70
7	4.88		103		10.29
8	4.24		104		14.31
9		8.56	105		20.74
16		18.16	106		33.64
17		16.84	107		25.56
18		9.17	108		16.01
19		12.58	109		27.81
21		27.18	110		34.15
22		32.66	111		13.03
23		8.64	112		17.31
24		13.40	113		16.36
25		8.56	114	6.25	
26	5.19		115		35.10
29		8.64	116		29.58
31		9.62	117		29.15
32		37.54	118		45.84
33		61.88	119		35.58
34		41.51	120		43.88
35		48.26	121		8.38
36		21.30	122	4.26	
37		31.39	123	4.64	
38		35.13	124		12.26
39		17.92	125		18.28
41		10.16	126		16.73
42	5.43		127		6.80
43	5.12		128	3.94	
44	5.75		129		29.44
45	5.69		130		22.91
47		7.20	131		24.10
49		16.98	132		40.93
50		11.45	133		18.07
53	5.79		134		20.08
56		7.42	136		27.17
58		7.89	137		10.20
59	5.05		138	5.49	
74		9.08	139		8.59
76		10.02	140		7.07
77	4.94		142	4.32	
84	6.32		144		5.25
85		18.83	145		32.66
86		13.03	148		22.53
87		14.78	149		17.03
89		26.62	150		8.67
90		18.67	154		8.22
91		8.59	156	5.94	
92	4.86		157		13.41
93		17.22	158		9.23
94	5.93		159		21.06
96		10.28	160		19.16
97		44.25	161		10.19

Question #	Significant ( $x^2$ 3.84)	Highly Significant ( $x^2$ 6.64)	Question #	Significant ( $x^2$ 3.84)	Highly Significant ( $x^2$ 6.64)
162		13.81	223		18.15
163		13.67	224		9.48
164		8.89	225		9.55
166	5.23		226		17.37
167	4.70		227		13.93
169	6.06		228		11.54
170		16.54	229		8.72
171		31.88	230		9.71
172		15.79	231		10.17
173		28.87	232		16.80
174		32.96	233		16.80
176		31.88	234		7.66
177		34.75	235		7.95
178		9.81	236		9.26
179		25.50	237	4.40	
180		17.90	238	5.65	
181		55.60	239	6.56	
182		51.32	241	4.91	
183		31.72	242		9.17
184		18.18	243	4.86	
186	3.97		248	5.43	
188		31.10	249		14.82
189		20.68	251		14.78
190		9.18	252		9.17
191		16.22	253		16.38
192		23.38	256		34.97
193		23.79	258		49.49
194		22.81	259		5.76
195		26.95	260	4.08	
196		17.67	261	5.64	
197		8.14	262	3.88	
198		7.18	265		9.00
199		22.90	266		14.82
200		50.94	271		16.37
201		8.84	272		9.08
202		12.55	273		12.43
203		18.86	274		9.17
205		18.86	275		17.28
207		4.29	277		35.56
208		26.21	282		11.84
209		13.27	283		31.09
210		9.36	284		13.96
211		23.11	285		16.26
212		22.01	286		9.92
213		28.93	287		40.54
214		22.04	288		12.61
216		48.84	289	4.96	
217		27.18	291		20.62
218		35.44	292		15.79
219		10.71	293		18.86
220		12.84	294		14.22
221		11.17	296		12.93
222		27.91	297		6.99
			298		26.54

Question #	Significant ( $x^2$ 3.84)	Highly Significant ( $x^2$ 6.64)	Question #	Significant ( $x^2$ 3.84)	Highly Significant ( $x^2$ 6.64)
299		72.51	410		18.83
301		6.65	412		15.13
302	6.25		413		10.92
305		15.08	414		23.42
308		7.17	416		21.42
310		9.49	418		27.59
311		8.59	419		18.95
312		32.66	420		17.06
313		26.21	421		56.12
315		22.14	422	5.28	
317	4.08		423	6.55	
351	4.00		424		22.83
352		20.93	425		38.65
353		24.23	426		9.08
354		206.47	427		13.40
355		14.01	429		12.33
356		31.52	430		17.34
357		20.47	431		7.10
358		23.13	432		29.71
359		36.18	433		6.98
360		35.86	436		43.24
361		46.97	437	4.98	
362		26.83	439		35.56
363		30.27	440		26.46
364		22.45	441		24.75
365		50.22	442		13.40
366	5.17		443		21.46
367		18.83	444		6.78
369		15.51	446		13.10
371		7.57	448		7.71
373		26.54	450		20.15
374		13.03	451		40.93
377		7.53	452		55.07
378		7.11	458		15.14
380		10.43	460		8.28
382		19.16	461		31.92
386		17.90	462		9.81
387		8.67	463		19.16
388	5.18		467		8.56
390	5.86		469		9.68
391		13.40	470		29.99
392		18.83	471		9.54
396		63.52	472		38.02
397		27.21	473	5.36	
398		50.69	474		12.30
399		36.74	475		10.50
401		38.04	476		17.04
403		25.98	477		27.22
404		9.17	478		28.34
407		34.54	479		49.91
408		28.52	480		42.96
409		16.46	484		20.95
			485		18.89

Question #	Significant ( $x^2$ 3.84)	Highly Significant ( $x^2$ 6.64)	Question #	Significant ( $x^2$ 3.84)	Highly Significant ( $x^2$ 6.64)
486		7.22	573	5.75	
487		28.80	577		8.55
488		13.38	578		6.76
489		11.40	579		11.84
490		18.28	580		11.97
491		29.15	583		21.26
492		13.03	584		16.40
493		19.77	585		15.58
496		11.96	586		6.68
499		10.55	587		18.48
500		14.51	588		19.45
501		33.72	589		7.88
502		35.65	590		9.94
503		41.28	591	5.67	
504	5.23		594		16.51
506		17.92	595		27.04
508		27.01	597		52.08
510		8.59	598	6.25	
512		24.20	599		13.41
513		9.52	600		9.08
516		5.37	601	3.97	
519		41.28	602		27.04
520		24.19	604		9.24
521		10.71	605	5.51	
522		11.17	606		8.11
523		11.17	607		30.38
524	4.79		608		44.15
525		6.51	610		10.52
530		14.22	611		28.08
531		10.24	612		19.16
534		10.20	613		33.48
537		7.65			
538	4.08				
539	4.73				
540		10.64			
543		22.42			
544		6.99			
546		18.03			
547		25.64			
548		21.47			
554		8.67			
555		22.96			
556		10.97			
558		6.91			
561	4.51				
562	6.60				
566	4.34				
567	3.93				
568		7.10			
569		7.08			
571		24.19			
572		18.04			

## DISTRIBUTION LIST

### Navy

- 4 Dr. Marshall J. Farr, Director  
Personnel and Training Research Programs  
Office of Naval Research (Code 458)  
Arlington, VA 22217
- 1 ONR Branch Office  
495 Summer Street  
Boston, MA 02210  
ATTN: Dr. James Lester
- 1 ONR Branch Office  
1030 East Green Street  
Pasadena, CA 91101  
ATTN: Dr. Eugene Gloye
- 1 ONR Branch Office  
536 South Clark Street  
Chicago, IL 60605  
ATTN: Dr. Charles E. Davis
- 1 Dr. M.A. Bertin, Scientific Director  
Office of Naval Research  
Scientific Liaison Group/Tokyo  
American Embassy  
APO San Francisco 96503
- 1 Office of Naval Research  
Code 200  
Arlington, VA 22217
- 6 Director  
Naval Research Laboratory  
Code 2627  
Washington, DC 20390
- 1 Technical Director  
Navy Personnel Research and  
Development Center  
San Diego, CA 92152
- 1 Assistant Deputy Chief of Naval  
Personnel for Retention Analysis  
and Coordination (Pers 12)  
Room 2403, Arlington Annex  
Washington, DC 20370
- 1 LCDR Charles J. Theisen, Jr.,  
MSC, USN  
4024  
Naval Air Development Center  
Warminster, PA 18974
- 1 Dr. Lee Miller  
Naval Air Systems Command  
AIR-413E  
Washington, DC 20361
- 1 Commanding Officer  
U.S. Naval Amphibious School  
Coronado, CA 92155
- 1 Chairman  
Behavioral Science Department  
Naval Command & Management Division  
U.S. Naval Academy  
Annapolis, MD 21402
- 1 Chief of Naval Education & Training  
Naval Air Station  
Pensacola, FL 32508  
ATTN: CAPT Bruce Stone, USN
- 1 Mr. Arnold I. Rubinstein  
Human Resources Program Manager  
Naval Material Command (0344)  
Room 1044, Crystal Plaza #5  
Washington, DC 20360
- 1 Dr. Jack R. Borsting  
U.S. Naval Postgraduate School  
Department of Operations Research  
Monterey, CA 93940
- 1 Director, Navy Occupational Task  
Analysis Program (NOTAP)  
Navy Personnel Program Support  
Activity  
Building 1304, Bolling AFB  
Washington, DC 20336

- 1 Office of Civilian Manpower Management  
Code 64  
Washington, DC 20390  
ATTN: Dr. Richard J. Niehaus
- 1 Chief of Naval Reserve  
Code 3055  
New Orleans, LA 70146
- 1 Chief of Naval Operations  
OP-987P7  
Washington, DC 20350  
ATTN: CAPT H.J.M. Connery
- 1 Superintendent  
Naval Postgraduate School  
Monterey, CA 93940  
ATTN: Library (Code 2124)
- 1 Mr. George N. Graine  
Naval Sea Systems Command  
SEA 047C12  
Washington, DC 20362
- 1 Chief of Naval Technical Training  
Naval Air Station Memphis (75)  
Millington, TN 38054  
ATTN: Dr. Norman J. Kerr
- 1 Principal Civilian Advisor  
for Education and Training  
Naval Training Command, Code 00A  
Pensacola, FL 32508  
ATTN: Dr. William L. Maloy
- 1 Director  
Training Analysis & Evaluation Group  
Code N-00t  
Department of the Navy  
Orlando, FL 32813  
ATTN: Dr. Alfred F. Smode
- 1 Chief of Naval Education and  
Training Support (OIA)  
Pensacola, FL 32509
- 1 Navy Personnel Research  
and Development Center  
Code 01  
San Diego, CA 92152

- 5 Navy Personnel Research  
and Development Center  
Code 02  
San Diego, CA 92152  
ATTN: A.A. Sjöholm
- 2 Navy Personnel Research  
and Development Center  
Code 306  
San Diego, CA 92152  
ATTN: Dr. J.H. Steinemann
- 2 Navy Personnel Research  
and Development Center  
Code 309  
San Diego, CA 92152  
ATTN: Mr. R.P. Thorpe
- 1 Navy Personnel Research  
and Development Center  
San Diego, CA 92152  
ATTN: Library

Army

- 1 Technical Director  
U.S. Army Research Institute for the  
Behavioral and Social Sciences  
1300 Wilson Boulevard  
Arlington, VA 22209
- 1 Armed Forces Staff College  
Norfolk, VA 23511  
ATTN: Library
- 1 Commandant  
U.S. Army Infantry School  
Fort Benning, GA 31905  
ATTN: ATSH-DET
- 1 Deputy Commander  
U.S. Army Institute of Administration  
Fort Benjamin Harrison, IN 46216  
ATTN: EA
- 1 Dr. Stanley L. Cohen  
U.S. Army Research Institute for  
the Behavioral and Social Sciences  
1300 Wilson Boulevard  
Arlington, VA 22209

1 Dr. Ralph Dusek  
U.S. Army Research Institute for the  
Behavioral and Social Sciences  
1300 Wilson Boulevard  
Arlington, VA 22209

1 HQ USAREUR & 7th Army  
ODCSOPS  
USAREUR Director of GED  
APO New York 09403

1 ARI Field Unit - Leavenworth  
Post Office Box 3122  
Fort Leavenworth, KS 66027

1 Dr. Milton S. Katz, Chief  
Individual Training & Performance  
Evaluation  
U.S. Army Research Institute for the  
Behavioral and Social Sciences  
1300 Wilson Boulevard  
Arlington, VA 22209

Air Force

1 Research Branch  
AF/DPMYAR  
Randolph AFB, TX 78148

1 Dr. G.A. Eckstrand (AFHRL/AST)  
Wright-Patterson AFB  
Ohio 45433

1 AFHRL/DOJN  
Stop #63  
Lackland AFB, TX 78236

1 Dr. Martin Rockway (AFHRL/TT)  
Lowry AFB  
Colorado 80230

1 Dr. Alfred R. Fregly  
AFOSR/NL  
1400 Wilson Boulevard  
Arlington, VA 22209

1 Dr. Sylvia R. Mayer (MCIT)  
Headquarters Electronic Systems Division  
LG Hanscom Field  
Bedford, MA 01730

1 AFHRL/PED  
Stop #63  
Lackland AFB, TX 78236

Marine Corps

23 Commandant of the Marine Corps (Code RI  
Headquarters, United States Marine  
Corps  
Washington, DC 20380

Coast Guard

1 Mr. Joseph J. Cowan, Chief  
Psychological Research Branch  
(G-P-1/62)  
U.S. Coast Guard Headquarters  
Washington, DC 20590

Other DOD

1 Military Assistant for Human  
Resources  
Office of the Secretary of Defense  
Room 3D129, Pentagon  
Washington, DC 20301

12 Defense Documentation Center  
Cameron Station, Building 5  
Alexandria, VA 22314  
ATTN: TC

Other Government

1 Dr. Lorraine D. Eyde  
Personnel Research and Development  
Center  
U.S. Civil Service Commission  
1900 E Street, N.W.  
Washington, DC 20415

1 Dr. William Gorham, Director  
Personnel Research and Development  
Center  
U.S. Civil Service Commission  
1900 E Street, N.W.  
Washington, DC 20415

1 U.S. Civil Service Commission  
Federal Office Building  
Chicago Regional Staff Division  
Regional Psychologist  
230 South Dearborn Street  
Chicago, IL 60604  
ATTN: C.S. Winiewicz

Miscellaneous

1 Dr. Gerald V. Barrett  
University of Akron  
Department of Psychology  
Akron, OH 44325

1 Dr. Bernard M. Bass  
University of Rochester  
Graduate School of Management  
Rochester, NY 14627

1 Dr. A. Charnes  
BEB 512  
University of Texas  
Austin, TX 78712

1 Dr. Rene' V. Dawis  
University of Minnesota  
Department of Psychology  
Minneapolis, MN 55455

1 Dr. Robert Dubin  
University of California  
Graduate School of Administration  
Irvine, CA 92664

1 Dr. Marvin D. Dunnette  
University of Minnesota  
Department of Psychology  
Minneapolis, MN 55455

1 ERIC  
Processing and Reference Facility  
4833 Rugby Avenue  
Bethesda, MD 20014

1 Dr. Edwin A. Fleishman  
Visiting Professor  
University of California  
Graduate School of Administration  
Irvine, CA 92664

1 Dr. M.D. Havron  
Human Sciences Research, Inc.  
7710 Old Spring House Road  
West Gate Industrial Park  
McLean, VA 22101

1 HumRRO Central Division  
400 Plaza Building  
Pace Boulevard at Fairfield Drive  
Pensacola, FL 32505

1 HumRRO/Western Division  
27857 Berwick Drive  
Carmel, CA 93921  
ATTN: Library

1 HumRRO Central Division/Columbus  
Office  
Suite 23, 2601 Cross Country Drive  
Columbus, GA 31906

1 HumRRO/ Western Division  
27857 Berwick Drive  
Carmel, CA 93921  
ATTN: Dr. Robert Vineberg

1 Dr. Lawrence B. Johnson  
Lawrence Johnson & Associates, Inc.  
2001 S Street, N.W., Suite 502  
Washington, DC 20009

1 Dr. Ernest J. McCormick  
Purdue University  
Department of Psychological Sciences  
Lafayette, IN 47907

1 Dr. Lyman W. Porter, Dean  
University of California  
Graduate School of Administration  
Irvine, CA 92650

1 Dr. Joseph W. Rigney  
University of Southern California  
Behavioral Technology Laboratories  
3717 South Grand  
Los Angeles, CA 90007

1 Dr. George E. Rowland  
Rowland and Company, Inc.  
P.O. Box 61  
Haddonfield, NJ 08033

- 1 Dr. Benjamin Schneider  
University of Maryland  
Department of Psychology  
College Park, MD 20742
  
- 1 Dr. Arthur I. Siegel  
Applied Psychological Services  
404 East Lancaster Avenue  
Wayne, PA 19087
  
- 1 Mr. George Wheaton  
American Institutes for Research  
3301 New Mexico Avenue, N.W.  
Washington, DC 20016