

AD-A032 666

ARMY ENGINEER WATERWAYS EXPERIMENT STATION VICKSBURG MISS F/G 8/8  
DIVIDE CUT DRAINAGE STRUCTURES, TENNESSEE-TOMBIGBEE WATERWAY, M--ETC(U)  
OCT 76 J H ABLES

UNCLASSIFIED

WES-TR-H-76-18

NL

1 OF 1  
AD A032666

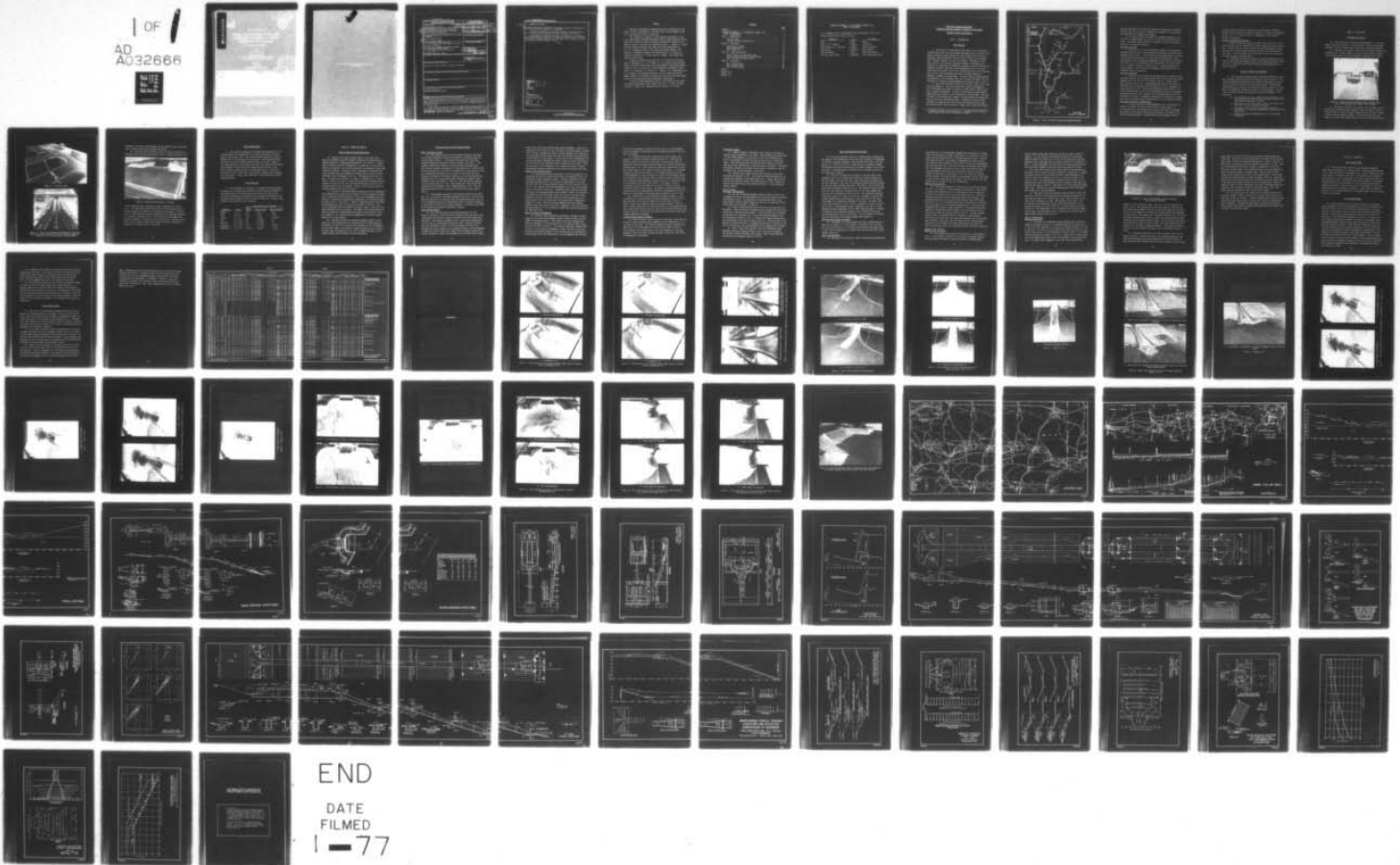

AD A U 32666

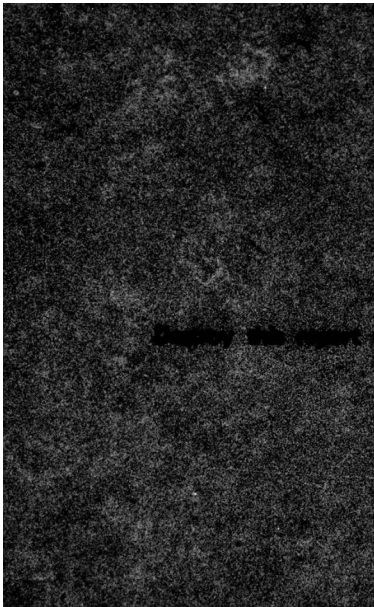

Unclassified

SECURITY CLASSIFICATION OF THIS PAGE (When Data Entered)

REPORT DOCUMENTATION PAGE		READ INSTRUCTIONS BEFORE COMPLETING FORM
1. REPORT NUMBER Technical Report H-76-18	2. GOVT ACCESSION NO. <b>14 WES-TR-H-76-18</b>	3. REPORT'S CATALOG NUMBER
6. TITLE (and Subtitle) DIVIDE CUT DRAINAGE STRUCTURES, TENNESSEE-TOMBIGBEE WATERWAY, MISSISSIPPI AND ALABAMA; Hydraulic Model Investigation.		5. TYPE OF REPORT & PERIOD COVERED 9. Final rep. Mar 74-May 75
7. AUTHOR(s) 10. Jackson H. Ables, Jr.	8. CONTRACT OR GRANT NUMBER(s)	
9. PERFORMING ORGANIZATION NAME AND ADDRESS U. S. Army Engineer Waterways Experiment Station Hydraulics Laboratory P. O. Box 631, Vicksburg, Mississippi 39180		10. PROGRAM ELEMENT, PROJECT, TASK AREA & WORK UNIT NUMBERS
11. CONTROLLING OFFICE NAME AND ADDRESS U. S. Army Engineer District, Nashville P. O. Box 1070 Nashville, Tennessee 37202		12. REPORT DATE 11. Oct 1976
14. MONITORING AGENCY NAME & ADDRESS (if different from Controlling Office)		13. NUMBER OF PAGES 66 (2) 82p.
		15. SECURITY CLASS. (of this report) Unclassified
16. DISTRIBUTION STATEMENT (of this Report) Approved for public release; distribution unlimited.		
17. DISTRIBUTION STATEMENT (of the abstract entered in Block 20, if different from Report)		
18. SUPPLEMENTARY NOTES		
19. KEY WORDS (Continue on reverse side if necessary and identify by block number) Drainage structures Tennessee-Tombigbee Waterway		
20. ABSTRACT (Continue on reverse side if necessary and identify by block number) Standardized designs for drainage structures in the Divide Cut Section of the Tennessee-Tombigbee Waterway were developed in model tests conducted on the USBR type VI impact basin at a scale of 1:4, on the minor drainage chutes and energy dissipators at a scale of 1:10, and on the major drainage structures at a scale of 1:25. Test results indicate that the type VI impact basin performs satisfactorily below rectangular channels for all discharges tested and (Continued)		

CONT Next

bpj

Unclassified

SECURITY CLASSIFICATION OF THIS PAGE(When Data Entered)

Cont. →

20. ABSTRACT (Continued)

critical dimensions are tabulated for discharges expected at drainage structures where the type VI basin will be installed.

Generalized information was developed to permit satisfactory design of minor drainage chutes and energy dissipators emptying into the canal.

A satisfactory baffled chute spillway was developed for the largest of the drainage structures. Model test results will permit design of the other three major structures based on a unit discharge of 60 cfs common to the five structures for 100-year frequency flows.

↖

ACCESSION for	
NTIS	White Section <input checked="" type="checkbox"/>
DOC	Buff Section <input type="checkbox"/>
UNANNOUNCED	<input type="checkbox"/>
JUSTIFICATION	
BY	
DISTRIBUTION/AVAILABILITY CODES	
Dist.	AVAIL. and/or SPECIAL
A	

Unclassified

SECURITY CLASSIFICATION OF THIS PAGE(When Data Entered)

## PREFACE

The model investigations reported herein were authorized by the Office, Chief of Engineers, on 7 February 1974, at the request of the U. S. Army Engineer District, Nashville.

The studies were conducted in the Hydraulics Laboratory of the U. S. Army Engineer Waterways Experiment Station (WES) during the period March 1974 to May 1975 under the general supervision of Messrs. H. B. Simmons, Chief of the Hydraulics Laboratory, and J. L. Grace, Jr., Chief of the Structures Division, and under the direct supervision of Mr. G. A. Pickering, Chief of the Locks and Conduits Branch. The engineer in immediate charge of the models was Mr. J. H. Ables, Jr., assisted by Messrs. H. O. Turner and W. A. Walker. This report was prepared by Mr. Ables.

During the course of the study, Mr. S. B. Powell of the Office, Chief of Engineers, Mr. W. W. Browne, Jr., of the Ohio River Division, Messrs. Ted Ablen, Bert Holler, and Julian Raynes of the South Atlantic Division, COL H. A. Hatch, CE, District Engineer, and Messrs. Herman Gray, H. F. Phillips, T. M. Allen, R. J. Connor, J. T. Hoffmeister, and N. B. Johnson of the Nashville District, and Mr. Wayne Odom of the Mobile District visited WES to discuss test results and correlate these results with design work being accomplished concurrently.

Directors of WES during the conduct of the studies and the preparation and publication of this report were COL G. H. Hilt, CE, and COL John L. Cannon, CE. Technical Director was Mr. F. R. Brown.

CONTENTS

	<u>Page</u>
PREFACE . . . . .	1
CONVERSION FACTORS, U. S. CUSTOMARY TO METRIC (SI)	
UNITS OF MEASUREMENT . . . . .	3
PART I: INTRODUCTION . . . . .	4
The Prototype . . . . .	4
Purpose of Model Investigations . . . . .	7
PART II: THE MODELS . . . . .	8
Description of Models . . . . .	8
Model Appurtenances . . . . .	11
Scale Relations . . . . .	11
PART III: TESTS AND RESULTS . . . . .	12
Type VI Impact Stilling Basin Model . . . . .	12
Chute and Splitter-Wall Dissipator Model . . . . .	13
Major Drainage Structures Model . . . . .	17
PART IV: DISCUSSION . . . . .	22
The 1:4-Scale Model . . . . .	22
The 1:10-Scale Model . . . . .	22
The 1:25-Scale Model . . . . .	23
TABLE 1	
PHOTOS 1-15	
PLATES 1-23	

CONVERSION FACTORS, U. S. CUSTOMARY TO METRIC (SI)  
UNITS OF MEASUREMENT

U. S. customary units of measurement used in this report can be converted to metric (SI) units as follows:

<u>Multiply</u>	<u>By</u>	<u>To Obtain</u>
feet	0.3048	metres
miles (U. S. statute)	1.609344	kilometres
square miles (U. S. statute)	2.589988	square kilometres
cubic yards	0.7645549	cubic metres
feet per second	0.3048	metres per second
cubic feet per second	0.02831685	cubic metres per second

DIVIDE CUT DRAINAGE STRUCTURES  
TENNESSEE-TOMBIGBEE WATERWAY, MISSISSIPPI AND ALABAMA  
Hydraulic Model Investigation

PART I: INTRODUCTION

The Prototype

1. The project, as authorized, would connect the north-flowing Tennessee River with the south-flowing Tombigbee River to provide a continuous navigation route suitable for modern barge traffic from the Tennessee, upper Mississippi, and Ohio River Valleys to the tidewater port of Mobile, Alabama, on the Gulf of Mexico. Subsequent actions have resulted in an approved plan which presently contemplates the extension of navigation from Demopolis, Alabama, on the existing Warrior-Tombigbee Waterway, upstream via the Tombigbee River and its tributaries and Yellow Creek to mile 215 on the sailing line of the Tennessee River in the existing Pickwick Lake near the common boundary of Tennessee, Alabama, and Mississippi. The total project length measured from Demopolis to the Tennessee River will be about 258 miles,\* and the difference in elevation between Demopolis and Pickwick pools is 341 ft.

2. The project has been divided into the River, Canal, and Divide Sections (Figure 1). The River Section will extend from Demopolis up the Tombigbee River about 173 miles to a point about 3 miles southwest of Amory, Mississippi. The plan for that reach includes channel improvement and a series of four conventional locks and dams. The next 45 miles of the waterway will consist of a canal formed by cutting into the left bank and constructing levees. Difference in water-surface elevations through the Canal Section will be overcome by five locks. The Divide Section, about 40 miles in length, will include Bay Springs

---

\* A table of factors for converting U. S. customary units of measurement to metric (SI) units is presented on page 3.

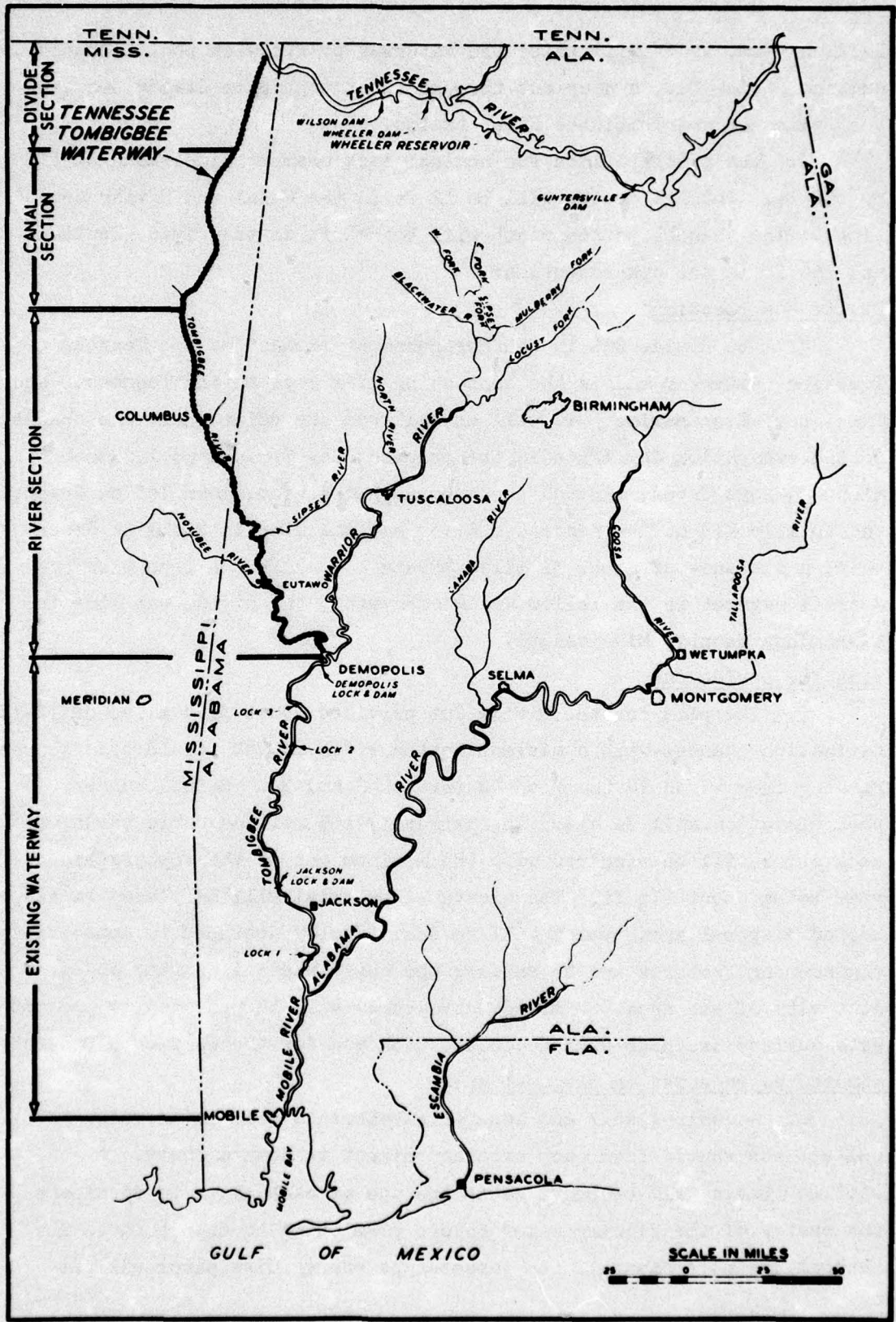

Figure 1. Map of proposed Tennessee-Tombigbee Waterway

Lock and Dam, which will raise the waterway to Pickwick pool elevation, and the Divide Cut, a deep cut through the topographic divide between the Tennessee and Tombigbee River basins.

3. The plan provides for nominal lock chamber dimensions of 110 by 600 ft. Channel depths will be 12 ft in the Canal and Divide Sections. The channel bottom width will be 280 ft in the Divide Section and 300 ft in the other sections.

#### Divide Cut location

4. The Divide Cut is the northernmost element of the Tennessee-Tombigbee Waterway and is the connecting link between the Tennessee and Tombigbee River basins. It will extend from the point where the channel bottom excavation daylights in the proposed Bay Springs pool, north along Mackeys Creek, through the topographic divide, down Yellow Creek, and to mile 215 on the Tennessee River sailing line in Pickwick Reservoir, a distance of about 31 miles (Plate 1). With the exception of a small segment in the Yellow Creek embayment, the Divide Cut lies in Tishomingo County, Mississippi.

#### Plan for Divide Cut

5. The plan for the Divide Cut provides about 31.4 miles of 12-ft navigation channel with a minimum bottom width of 280 ft and side slopes ranging from 4V on 1H to 1V on 4H (Plates 2 and 3). Normal summer pool elevation will be 414. Approximately 165 million cubic yards of excavation will be required with the maximum cut at the topographic divide being about 175 ft. The excavated material will be placed in selected disposal areas which will be individually designed to appropriate engineering features and to enhance the environmental quality and productivity of the area. Drainage structures will be provided to accommodate surface drainage during construction and for the completed project.

#### Structures proposed in disposal area

6. A control weir and lateral embankments will be provided to collect the runoff from each area and direct it down a chute. A stilling basin will be provided at the toe of each chute to dissipate the energy of the flowing water before permitting it to return to its natural drainage channel. An impact-type energy dissipator will be

provided similar to Basin VI reported in the publication, "Hydraulic Design of Stilling Basins and Energy Dissipators - Engineering Monograph No. 25," by A. J. Peterka of the U. S. Department of the Interior, Bureau of Reclamation.

#### Structures proposed in cut area

7. Where economically feasible, several small drains or a small and large drain will be connected by ditches leading to a common control weir. Chutes along the cut will serve small and intermediate drainage areas and have steeper grades and higher velocity flows than those on fill areas. Stilling basins will be provided at the end of the chutes serving the smaller drainage areas.

8. Pertinent data for all structures serving drainage areas less than 25 square miles are shown in Table 1, with typical structures shown in Plate 4. Data for the structures having larger drainage areas are shown in Plate 5.

#### Purpose of Model Investigations

9. Over one hundred small hydraulic drainage structures and five major drainage structures will be constructed in the Divide Cut of the Tennessee-Tombigbee Waterway, and all unsafe and undesirable characteristics should be corrected before they are installed. The hydraulic characteristics of several of the structures could not readily be determined by mathematical analyses and needed to be model-tested. Specifically, the model studies were expected to provide information on the following:

- a. Flow conditions and wall heights required upstream of the type VI basins as well as the size of these structures for the width-to-depth ratios involved.
- b. Performance of the intake weirs, chutes, and energy dissipators for the minor drainage structures.
- c. Performance of the baffled chute energy dissipators, specially for the high unit discharges encountered with the design flow.
- d. Riprap requirements downstream from all of the energy dissipators.

## PART II: THE MODELS

### Description of Models

10. Three models were used in the investigations: a 1:4-scale model of the type VI basin, a 1:10-scale model of the minor drainage structures, and a 1:25-scale model of the major drainage structures.

11. The model of the type VI basin, shown in Figure 2 and Plate 6, simulated 80 ft of chute length (4 ft wide) and the basin in plastic-coated plywood, and 50 ft of the riprapped trapezoidal exit channel.

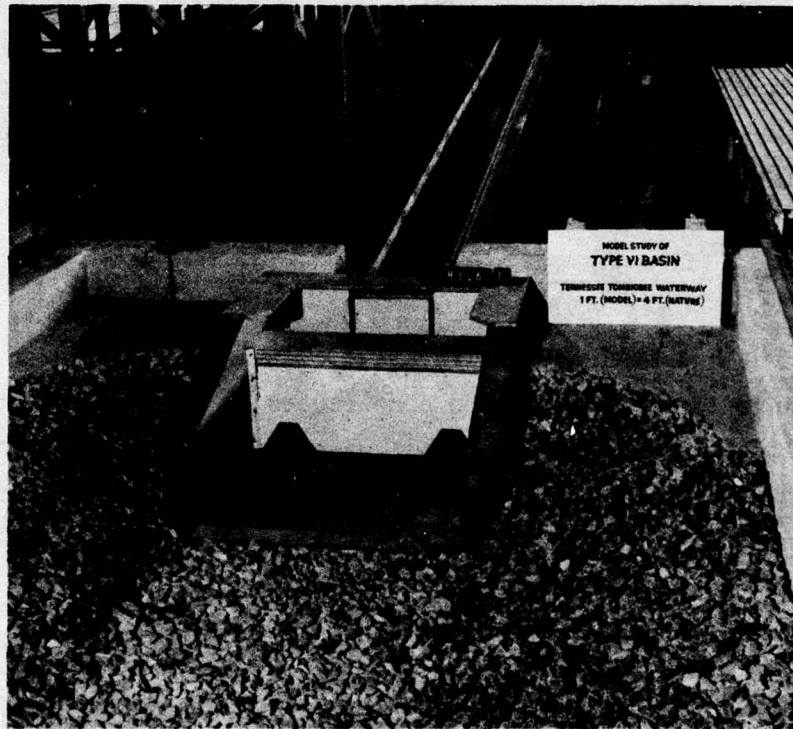

Figure 2. General view of head bay, chute, original impact basin, and riprapped exit channel, type VI basin

12. The study of the chute and splitter-wall dissipator was conducted with a 1:10-scale model (Figures 3 and 4 and Plate 7) that reproduced three of the exit channels downstream from the type VI basin, a portion of the connecting channel, the entrance transition, and chute (10 ft wide), the closed conduit section, and the splitter-wall

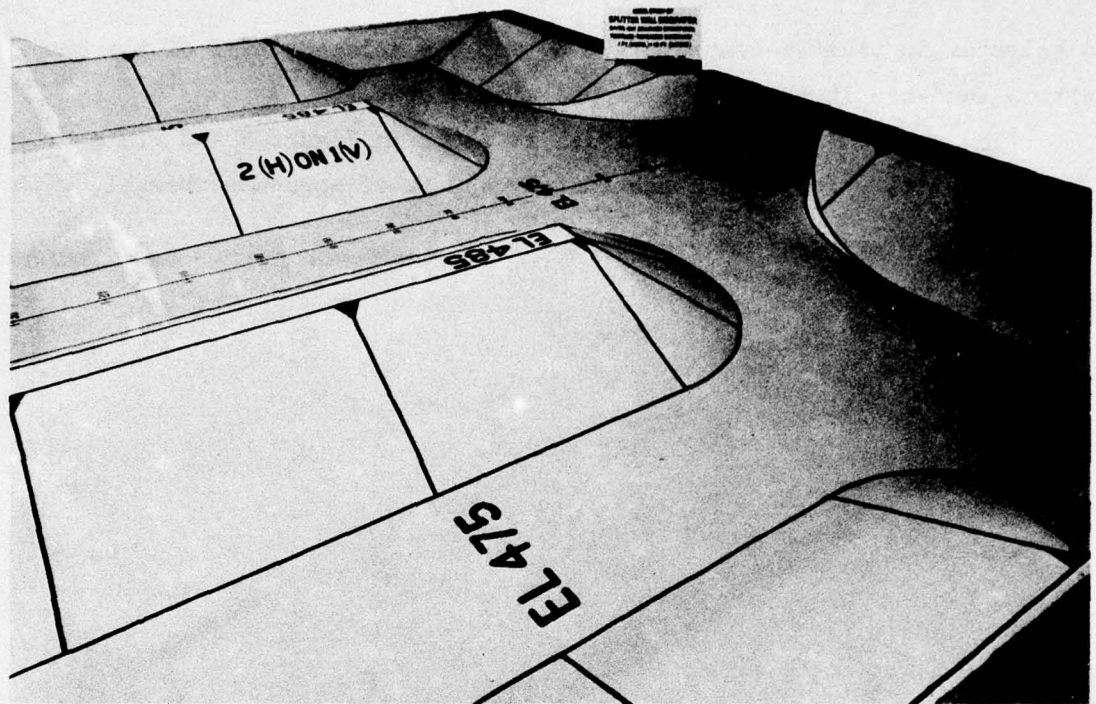

Figure 3. 1:10-scale model

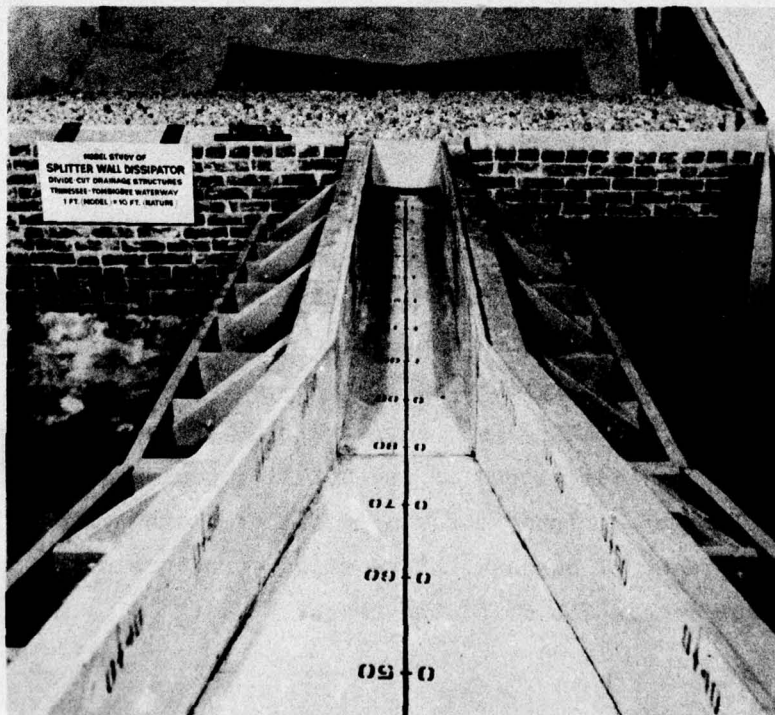

Figure 4. View from drainage area looking down transition, chute, and culvert junction into splitter-wall energy dissipator at toe of canal slope, 1:10-scale model

dissipator in plastic-coated plywood, and the adjacent half of the canal with a sand-bed invert and riprapped side slopes.

13. The major structure model is shown in Figure 5 and Plate 8. The model limits included approximately 450 ft of approach channel, with



Figure 5. Major structure model, 1:25 scale

a 600-ft approach width, including overbank, reproduced in concrete crust. The 168-ft-wide baffled chute with a 1V-on-2.5H slope with 11-ft-high sidewalls was fabricated in plastic-coated plywood. A 250-ft-wide by 150-ft-long stilling pool downstream of the chute was reproduced in a sand bed. The side slopes of the stilling pool and canal abutments had a blanket of riprap cover over filter cloth. The model reproduced a 625-ft reach of canal with the major structure stilling pool entering in the middle 250 ft of the reach.

### Model Appurtenances

14. Water used in operation of the models was supplied by a circulating system with measurements of discharge being made by venturi meters in the supply lines. Flow from the supply lines was stilled by baffles prior to its entrance into the models. After passing through the models, the water flowed by gravity back to the sump. Stages in the downstream ends of the channels and canal were controlled by adjustable tailgates. Steel rails set to grade along both sides of the models provided reference planes for measuring devices. Velocities were measured with a pitot tube; water-surface elevations were measured with point gages. Certain flow conditions in the models were recorded photographically.

### Scale Relations

15. The requirements of geometric and dynamic similarity between the models and prototype were satisfied by constructing all elements of the various models to an undistorted linear scale ratio and by converting model dimensions and quantities to prototype equivalents by use of proper scale relations as derived from the Froude law. General scale relations for the models were as follows:

<u>Dimension</u>	<u>Ratio</u>	<u>Scale Relations for Models</u>		
		<u>Type VI Basin</u>	<u>Splitter Wall</u>	<u>Major Structure</u>
Length	$L_r = L$	1:4	1:10	1:25
Area	$A_r = L^2$	1:16	1:100	1:625
Volume	$V_r = L^3$	1:64	1:1000	1:15,625
Time	$T_r = L^{1/2}$	1:2	1:3.1623	1:5
Velocity	$V_r = L^{1/2}$	1:2	1:3.1623	1:5
Discharge	$Q_r = L^{5/2}$	1:32	1:316.23	1:3,125
Mannings "n"	$N_r = L^{1/6}$	1:1.259	1:1.468	1:1.710

### PART III: TESTS AND RESULTS

#### Type VI Impact Stilling Basin Model

16. Design of the type VI basins (Table 1 and Plate 4) was based on information from the "Hydraulic Design of Stilling Basins and Energy Dissipators - Engineering Monograph No. 25" by the U. S. Department of Interior, Bureau of Reclamation, as published in 1963 and modification to section 6 of the above publication as published in June 1969 (Report No. HYD-572). The type VI basin reproduced in the model simulated the basin that was designed for drainage area 9L shown in Table 1 and Plate 4 with a discharge of 122 cfs. The approach chute was 4 ft wide. The basin was observed for a range of discharges up to a flow of 122 cfs. Plate 9 is a plot of water-surface profiles observed with discharges of 60 and 122 cfs, with uncontrolled tailwater, and with 4-ft tailwater depth in the exit channel. Photos 1 and 2 show the flow conditions observed with the type VI basin.

17. The type VI basin performed satisfactorily for all discharges. Flow conditions were good, and the riprap in the exit channel was stable for all tailwater elevations tested. Thus, it was recommended that the basins be constructed as designed with dimensions for the various basins as shown in Table 1 and Plate 4. Specific dimensions required when maximum discharges vary from 21 to 339 cfs are shown in Plate 10. Also, it was recommended that the riprap size shown in Table 1 and Plate 10 be used downstream from the structure. The length of the riprap protection could be decreased to approximately the width of the structure if the exit channel is on a stable grade and degradation of the exit channel material is not anticipated.

18. Although the chute wall heights proposed in Table 1 would retain the flow upstream from the structures with the anticipated low tailwaters, for which the structures were designed, it was recommended that the wall heights be increased as shown by dimension (g) in Plate 10 to ensure that overtopping will not occur if higher tailwater or discharges greater than the design flow are encountered.

## Chute and Splitter-Wall Dissipator Model

### Type 1 (original) design

19. The original chute and splitter-wall dissipator reproduced in the model simulated the structure designed for drainage areas 34L and 35L shown in Table 1. Flow entered the model chute from three channels immediately upstream as shown in Figure 3 and Plate 7. The original design chute leading to the splitter-wall dissipator had 36-ft-radius sidewalls converging to a 36-ft-wide weir at invert el 475. The chute dropped IV on 2.9H as it converged into a 10-ft width in 78 ft and continued an additional 96 ft to invert el 415, where the flow entered a 2-ft-high by 10-ft-wide culvert on a IV-on-3.3H slope for an additional 82.5 ft to the splitter-wall dissipator at invert el 390 (Figures 3 and 4 and Plates 4, 7, and 11). The canal invert adjacent to the dissipator was at el 396. Canal stages will vary from el 408 (minimum) to 418 (maximum), with a normal elevation of 414. The proposed locations for the cut section are listed on the right side of Table 1.

20. The headwater upstream of the entrance transition and chute was 4 to 5 ft deep with the design discharge of 900 cfs. Flow into and down the transition and chute was rough and diamond-patterned, and flow at the downstream culvert was sufficiently rough to prohibit conveyance of lower flows as well as the design discharge. A hydraulic jump formed in the culvert and reduced its hydraulic capacity.

### Type 2 chute entrance

21. The 10-ft-wide chute was extended upstream to el 475 (Plate 11 and Photo 3) and 30-ft-radius abutment walls were added, thus eliminating the 36-ft-wide entrance transition with 36-ft-radius abutment walls. This design, designated type 2, improved and smoothed the critical flow at the entrance and down the chute. However, the headwater was increased to about 9 ft with the design flow of 900 cfs. Although the culvert leading to the downstream splitter wall was passing the 900-cfs flow at minimum canal stage 408, the hydraulic jump in the culvert continued to create flow problems with the design flow at canal

stages above 408 as well as with lower chute discharges. Another disadvantage of the culvert was the ever-present prototype danger of having trees or debris clogging the chute or culvert entrance and resulting in flows spilling over the chute walls onto the riprapped slope protection, causing failure in these areas. At this point in the investigation, the decision was made to abandon the culvert, remove the roof, and develop a chute structure with smoother energy dissipation in the canal. Priority was given to the development of an entrance and chute to obtain satisfactory headwater depths and smooth flows into and down the chute.

#### Types 4 and 5 drop structures

22. Drop structures were considered to be the best means for introducing flow into the constant-width chute (no transition) while retaining the original headwater depths. Available information on drop spillways indicated that for the structure being modeled (10-ft-wide chute and 900 cfs) the drop structure should be 18 ft long with a drop of 6 ft. The original 36-ft-radius abutments were left in the original position (see type 4, Plate 11). Preliminary tests indicated the drop would solve the upstream approach depth problem; however, the structure as designed did not allow flow to enter all sides of the drop evenly. Therefore, the type 5 structure (Plate 11) was installed with a horizontal drop of 6 ft at sta 0+00 with a horizontal floor extending upstream to sta 0+30. The 30-ft-radius abutment walls were restored tangent to the chute walls at sta 0+00. Headwater at sta 1+20 upstream was approximately 4 ft for the 900-cfs design flow, and flow patterns in the chute were even.

#### Type 6 structure (recommended)

23. The type 5 drop structure was modified to include IV-on-2H slopes on the 30-ft-radius abutment curves as shown in Plate 11; this change was designated type 6. The length of the drop structure and radius of abutments will not always be 30 ft as shown in Plate 11 but will vary as shown in Plate 12. The length of horizontal channel shown in Plate 12 could cause the backwater to affect the head on the drop structure with high discharges. Since the model did not reproduce the entire length for all the structures, it was recommended that the drop

structures be designed to operate with weir control or that backwater curves be computed at each structure to determine what effect this will have on the head.

24. Calibration data were obtained with various lengths and depths of the type 6 structure as shown in Plate 12. These data are plotted in Plate 13 as ratios of the width of the chute so that the dimensions of the structures can be determined for a known discharge and allowable head. All of the calibration data were obtained with an abutment radius equal to three times the width of the chute. If it becomes necessary to increase the radius of the abutments because of the upstream embankment, as will probably be the case with the smaller chutes, the calibration curve shown in Plate 13 should be used for design since this curve was obtained without a drop structure ( $D = 0$ ) and the radius of the abutments will have little effect on discharge. Plate 14 illustrates a typical prototype drop structure in the cut area as developed from model test results. The method of developing individual drop structures as recommended and described in paragraphs 23 and 24 was adopted for development of prototype drop structures in the cut area.

25. Typical type 6 drop structures are shown in Photo 4. Flow conditions in a 10-ft-wide chute passing a discharge of 900 cfs with no drop and with a 6-ft-drop and length of 30 ft are shown in Photo 5. Photo 5c shows flow conditions with the discharge reduced to 500 cfs. Plates 12 and 15 show plots of bottom velocities at the upstream approach and a water-surface profile with the type 6 drop structure passing a discharge of 900 cfs; the 900-cfs flow enters the drop structure from three channels immediately upstream.

#### Original design energy dissipator

26. After the type 6 drop structure was developed, tests were conducted to develop optimum energy dissipation at the downstream end of the chute in the canal. The original energy dissipator consisted of an impact wall at the downstream end of the chute as shown in Plate 4. Flow conditions were unsatisfactory with this design due to the high buildup of flow at the water surface as shown in Photo 3b. This would be detrimental to navigation.

### Dissipator schemes

27. Several schemes of dissipation were tested in an effort to improve energy dissipation in the canal. These schemes were tested with a 1-on-8 flared expansion in the last 40 ft of the 10-ft-wide chute walls in an attempt to spread the high-velocity jet as it entered the canal. Observations were made with several apron lengths at el 390 and with various combinations of baffles placed on the apron. Velocities and surface turbulence were high with this type of dissipator, and considerable scour occurred adjacent to the apron.

28. Several rows of baffle blocks were installed on the chute below minimum tailwater el 408. This improved energy dissipation by increasing the thickness of the high-velocity jet. A short apron with an end sill was installed between the flared walls at el 396. Energy dissipation was improved with this design and the scour in the canal was greatly reduced.

### Type 18 energy dissipator (recommended)

29. The type 18 energy dissipator shown in Plates 14 and 15 was recommended for use at the downstream end of the chutes where flow enters the navigation canal. All dimensions of the basin are based on the chute width,  $W$ , and the baffle blocks and end sill are functions of the normal depth down the chute,  $D$  (Table 1).

30. Plate 15 shows velocity cross sections in the canal near the dissipator. Photo 6a shows the dissipator with riprapped 1V-on-2.5H side slopes and a downstream riprap blanket. Photo 6b shows scour resulting from operation of the model for 1 hr with the design discharge of 900 cfs and minimum tailwater el 408. A similar test without riprap protection downstream of the basin is shown in Photo 6c. The scour was not excessive in either case; and if an adequate cutoff wall is provided at the end of the structure, the riprap protection will probably not be needed.

31. Photo 7 shows flow conditions with the recommended energy dissipator passing a design discharge of 900 cfs with 418 (maximum), 414 (normal), and 408 (minimum) canal stages. Photo 8 shows flow conditions with the discharge reduced to 500 cfs.

### Major Drainage Structures Model

32. The major drainage structures or baffled chute spillways and the heights of the abutment and chute walls were designed to accommodate the 100-year frequency discharge. The structures will have a unit discharge,  $Q$ , of 60 cfs per foot of width and are to maintain a reasonable entrance flow when transitioning from natural channel to the stilling device. Pertinent data for the four major structures are given in the tabulation in Plate 5.

33. The Little Yellow Creek structure on the left bank of the navigation canal at sta 13165+50 was selected for model testing as it was the largest; and since the other three structures are similar and the unit discharge is the same, the recommended design would be adequate for the four major drainage structures. The width of the structure was 168 ft and the sidewall height was 11 ft. The 100-year design flood was 9700 cfs. The chute had a bottom slope of IV on 2H and dropped from crest el 422 to stilling pool invert el 390. The trapezoidal approach transition flared (1:3) from 40 to 168 ft in a distance of 192 ft with a grade change from el 422 upstream to 420 at the 168-ft crest width which began 30 ft immediately upstream of the chute. The chute crest at sta 0+00 returned to el 422. Prior to completion of model construction, the U. S. Army Engineer District, Nashville, and the U. S. Army Engineer Waterways Experiment Station (WES) engineers agreed to attempt to develop a more economical dissipator with a hydraulic-jump type stilling basin near the toe of the slope. For this reason, the baffles were not installed on the original design chute (Figure 5).

#### Stilling basin energy dissipators

34. Performance of stilling basins with apron lengths between 15 and 25 ft at invert el 396 were observed. The grade of the stilling pool invert was raised 6 ft to coincide with the apron and canal invert el 396. Various combinations of baffle piers and end sills were investigated (Plate 16).

#### Type 4 stilling basin

35. The type 4 stilling basin (Plate 16) performed satisfactorily.

This basin had a 15-ft-long apron equipped with 2-ft-high by 2-ft-wide baffle blocks spaced 2 ft apart, positioned 7.5 ft from the toe of the apron, and was terminated with a 2-ft-high sloping end sill. Observations were made with a full range of discharges up to 9700 cfs with the tailwater varied between el 408 and 418. Velocity and photographic data were collected with a 9700-cfs discharge and minimum canal stage of 408. The middepth velocities in Plate 17 show velocities as high as 9 fps entering the canal from the stilling pool area at sta 2+25.7. Confetti streaks with a time exposure of 7.5 sec (Photo 9) indicate surface currents with eddy patterns on each abutment and up to the right of the structure (upstream) in the canal. All flow from the canal was passing over a tailgate to the left (downstream).

#### Type 10 stilling basin

36. Tests were conducted with the width of the structure reduced to 100 ft in an effort to effect economy in construction. This raised the upper pool approximately 1.8 ft, increased the unit discharge to 97 cfs, and the depth of the flow on the chute to 2.5 ft. Tests were conducted with various apron lengths and baffle block heights. The optimum design basin for the 100-ft-wide structure had a 25-ft-long apron with a row of 2.5-ft-high baffle piers positioned 10 ft from the toe of the apron and a 2.5-ft-high sloping end sill. This basin was designated type 10 and is shown in Plate 16. Velocities entering the canal were concentrated near the middle of the stilling pool and increased to as high as 13 fps as shown in Plate 17. Surface currents shown in Photo 10 indicated that the strengths of water-surface velocities and currents into the canal were magnified with the narrower type 10 design. Wave action was more severe on the riprapped slope protection on the abutments and canal bank opposite the structure. Thus, no additional tests were conducted with the 100-ft-wide structure.

#### Baffled chute spillway types 11, 12, 13, and 14

37. The minimum canal stage of 408 results in a canal depth of 12 ft. In an attempt to spread the flow from the drainage structure into the canal and minimize navigation problems to waterway barge

traffic, baffle blocks were placed on the chute as shown in Plate 18 (type 11). At the request of the Nashville District, the upstream approach channel was raised 2 ft to crest el 422, making the approach horizontal and at the same time restoring the width of the structure to 168 ft. Overall dissipation was good with very little riprap movement; and at sta 2+25, middepth velocities entered the canal at 5.6 fps.

38. Tests were conducted with several baffle locations and lip elevations; some of these are shown in Plate 18. In the type 13 design, the baffle blocks were positioned according to USBR Monograph No. 25 (face of first row of baffles at el 423, 1 ft below the crest of the lip at el 424). The upstream profile showed the pool at about el 431 upstream to sta 0+25; then drawdown occurred, giving a lower upper pool than with the types 11 and 12. Velocities at sta 0+23 upstream averaged about 7 fps. Velocities at sta 2+25 downstream were well distributed with a high of 6.4 fps at middepth.

39. The type 14 chute was identical with the type 13 (Plate 18) except the invert of the stilling pool area immediately downstream of the chute was lowered 6 ft from el 396 to 390. This was done with the canal invert remaining at el 396. The additional 6-ft depth in the stilling pool area permitted a better velocity distribution as flow entered the canal at sta 2+25 (Plate 19). Surface currents are shown in Photo 11. The improvement of flow conditions can be seen by comparing the type 4 stilling basin (Plate 17 and Photo 12) with the type 14 baffled chute (Plate 19 and Photo 11).

Type 15 (recommended)  
design baffled chute

40. The type 15 (recommended) design baffled chute is shown in Figure 6 and Plates 18 and 20. The upstream approach was sloped from el 422 at sta 2+30 upstream to el 420 at sta 0+30 and remained at el 420 to sta 0+05. The crest lip of the 168-ft-wide chute was fixed at el 422 and the chute slope of IV on 2H dropped to invert el 382.4. The sloping chute wall height was raised 1 ft to 12 ft. Eight rows of 5.625-ft-wide by 3.75-ft-high baffles spaced 5.625 ft horizontally on the chute were used. The baffles were staggered in rows that were longitudinally

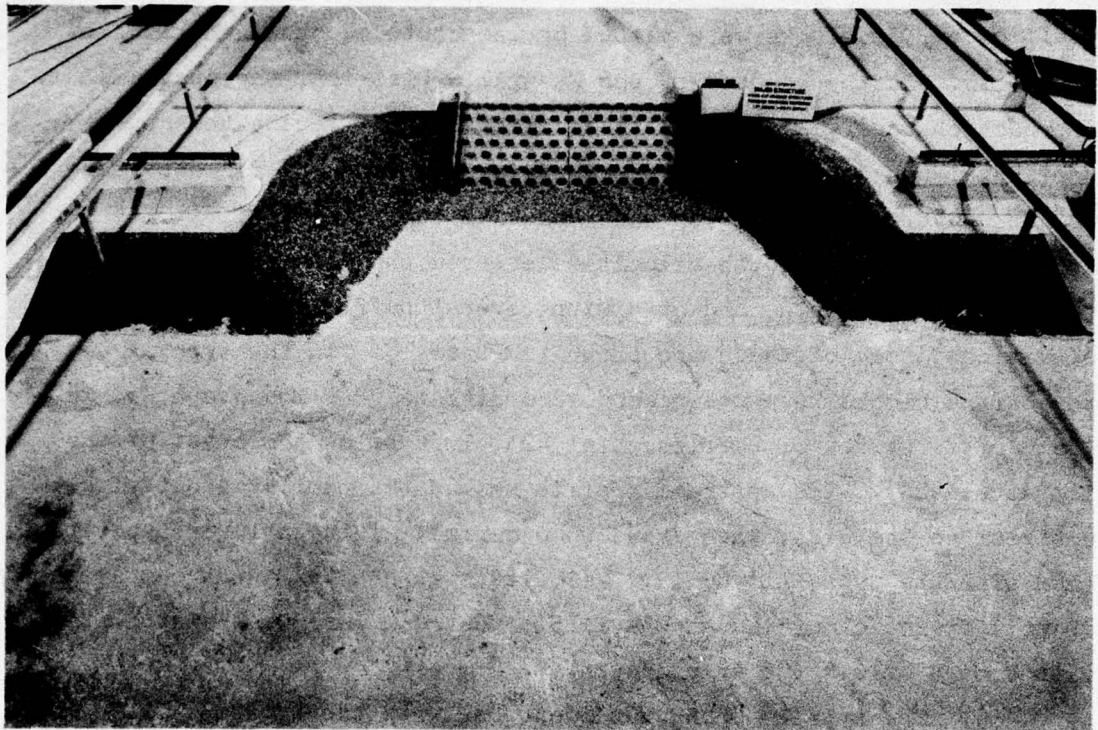

Figure 6. Type 15 (recommended) structure showing stilling pool abutments

spaced at 11.25 ft down the slope. The toe of the most upstream row was at el 421. The stilling pool invert was fixed at el 390 and the 50-ft-long riprap blanket at the toe of the chute passed over and above the top of the eighth row of baffles and wrapped around the downstream face and sides of the seventh row. As shown in Plate 20, the IV-on-2.5H side-slope abutments were flared to reduce the area available for eddy formations and to maintain better control of flow from the stilling pool area entering the canal at invert el 396. This also represents a cost saving at the four major drainage structures. Provisions were made in the model to pass discharge upstream as well as downstream from the canal.

41. Discharge calibration curves for the type 15 structure are shown in Plate 21. Bottom velocities in the upstream approach to the spillway and middepth velocities downstream are plotted in Plate 22. These velocities were measured with the design discharge of 9700 cfs and

canal stage of 408 and with flow into the canal divided upstream and downstream. Additional velocity measurements were made with the minimum canal stage of 408 as the discharge was reduced in steps to 5000 cfs, at which point the maximum velocity at middepth was reduced to 3 fps. This was the preferable velocity with respect to navigation in the canal. There was no wave attack on the riprapped slopes in the stilling pool or canal for the full range of spillway flows. Plate 23 shows a water-surface profile along the left wall of the baffled chute. Surface flow patterns are shown by means of confetti streaks in Photo 12. Flow conditions with the 9700-cfs design flow and 5000-cfs flow with canal stages of 408 and 418 are shown in Photos 13 and 14, respectively. Photo 15 shows the result of scour downstream of the type 15 structure after 5-hr operation with a discharge of 9700 cfs and canal stage of 408. The riprap plan as designed was stable for all flows tested.

42. The stilling pool was reduced from a constant width of 250 (original design) to 168 ft at the end of the chute walls and 240 ft at the canal as shown in Plate 20. Several alignments were tested, but the shape and riprap limits shown in Plate 20 were found to be optimum and were recommended. Although the other major structures will have different widths, they should be proportioned geometrically the same as the structure that was model-tested.

## PART IV: DISCUSSION

### The 1:4-Scale Model

43. The type VI impact basin for use with open rectangular chutes was investigated in a 1:4-scale model. The basin performed well with a 4-ft-wide channel and discharges up to 122 cfs (design flow) with a full range of tailwater conditions. Flow conditions and dissipation were excellent, and riprap designed for the exit channel was stable for all conditions tested. Although the chute wall heights of the original design retained the flow upstream from the structure with the anticipated low tailwater for which the structure was designed, it was recommended that the wall heights be increased to ensure that overtopping will not occur if higher tailwater or discharges greater than the design flows are encountered.

### The 1:10-Scale Model

44. Tests conducted in the 1:10-scale model of the chute and energy dissipator for the minor drainage area structures revealed that entrance conditions to the chute and flow conditions in the covered chute and at the impact (splitter wall) energy dissipator were unsatisfactory. A drop structure was developed for use at the entrance to the chute. This modification eliminated the need for a flared transition while retaining the headwater upstream at an acceptable level. Discharge-headwater calibration data were obtained with several drop structure lengths and depths. These data are presented as ratios of the chute width so that the required dimensions of the various structures can be determined for known discharge and allowable head. The length of the horizontal channel could cause the backwater to affect the head on the drop structure with high discharges. Since the model did not reproduce all the possible lengths, it was recommended that the drop structures be designed to operate with weir control or that backwater curves be computed at each structure to determine what effect this will have on head.

45. A hydraulic jump formed in the covered section at the downstream end of the chute. This caused the culvert to flow full and the higher canal stages resulted in flow spilling over the chute walls. Also, any debris entering the chute would likely clog the culvert. Thus, it was recommended that the roof be removed in this area.

46. An undesirable buildup of flow occurred at the water surface of the canal with the original impact wall energy dissipator. A hydraulic-jump type energy dissipator was developed that resulted in satisfactory flow conditions in this area. The dimensions of the basin and its elements were expressed as functions of the width of the chute and the depth of flow in the chute for the design discharge. Thus, the basins for the structures not modeled can be designed from results of these tests.

#### The 1:25-Scale Model

47. Model tests to develop major drainage structures were conducted in a 1:25-scale model of the largest structure, Little Yellow Creek. These structures were all designed to accommodate 100-year frequency flows with a unit discharge of approximately 60 cfs. Although tests were conducted on only the largest structure, the other structures are similar and the unit discharge is the same so this design should be adequate for all the major structures.

48. In an effort to effect economy in construction of the major drainage structures, tests were conducted without blocks on the chute and with short hydraulic-jump type energy dissipators at the toe of the chutes with both 168- and 100-ft-wide structures. Stilling basins were developed for both of these widths, but maximum velocities entering the navigation canal were higher than desirable (9 fps).

49. Baffle blocks were added to the chute in an effort to distribute velocities more evenly over the cross-sectional area of the stilling pool. Several arrangements of the baffles were tested and a satisfactory design was developed. The alignment of the stilling pool side slopes was changed in order to better distribute flow into the

canal. Maximum velocities entering the canal were 6 fps with the design discharge (60 cfs/ft). Although flow was well distributed across the stilling pool with the recommended design, velocities with the design discharge would be detrimental to navigation. Therefore, tests were conducted to determine the discharge at which velocities entering the canal would be limited to 3 fps. This discharge was found to be approximately 30 cfs/ft.





PHOTOGRAPHS

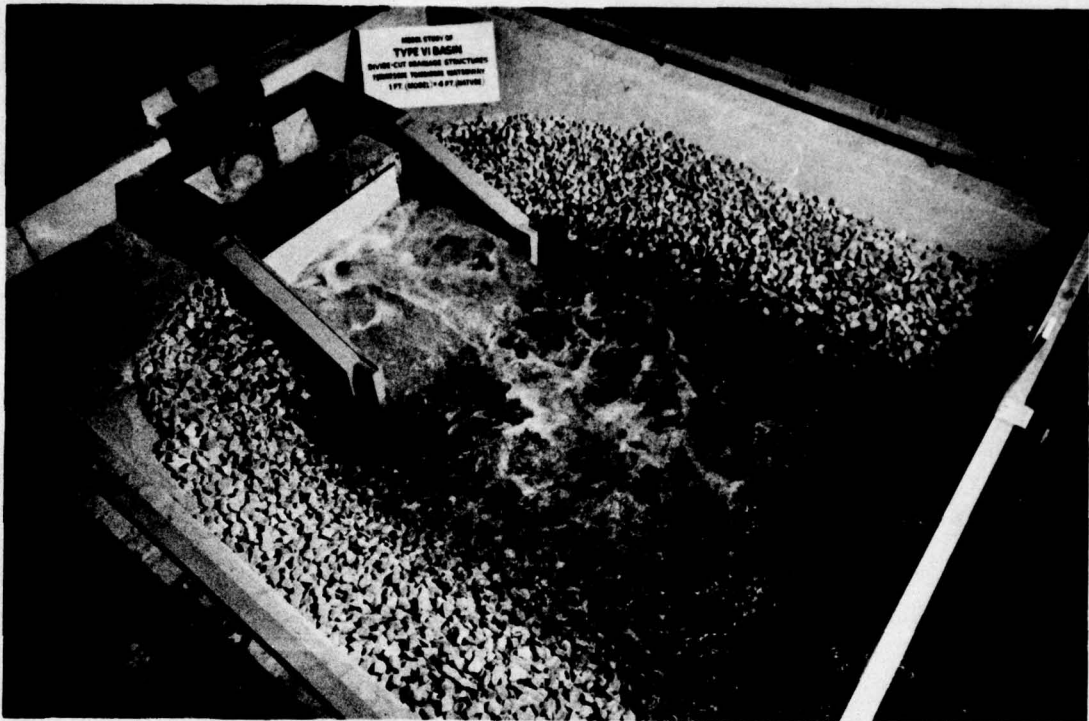

a. Tailwater uncontrolled

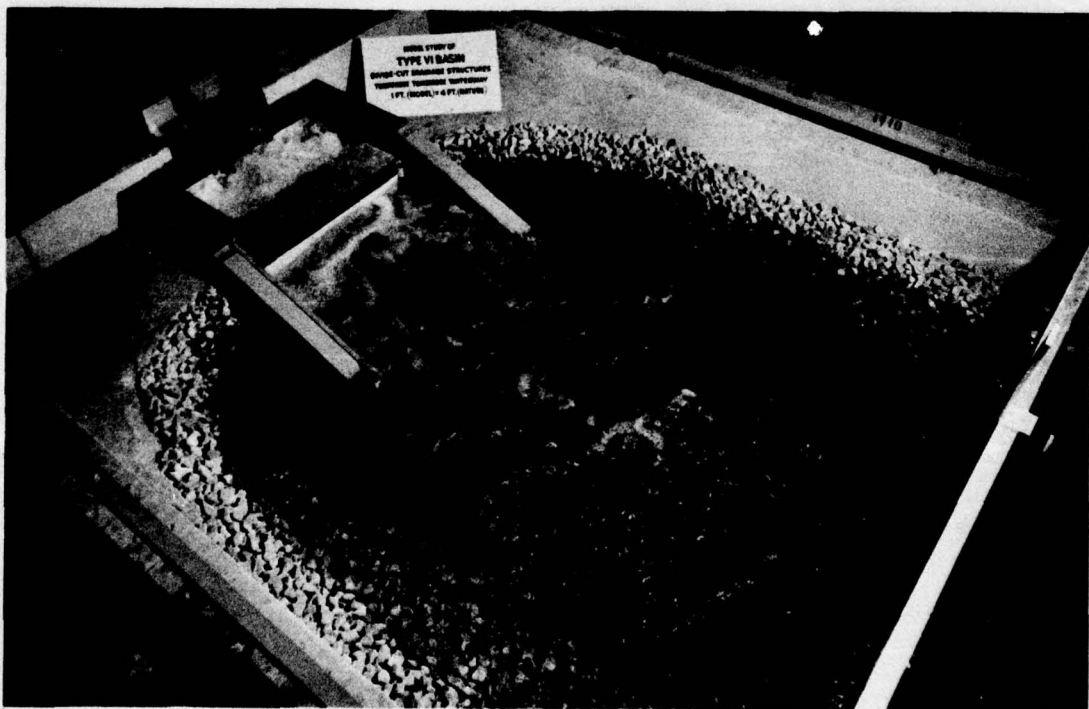

b. Tailwater 4 ft

Photo 1. Flow conditions with original design impact basin; 4-ft-wide chute, discharge 122 cfs

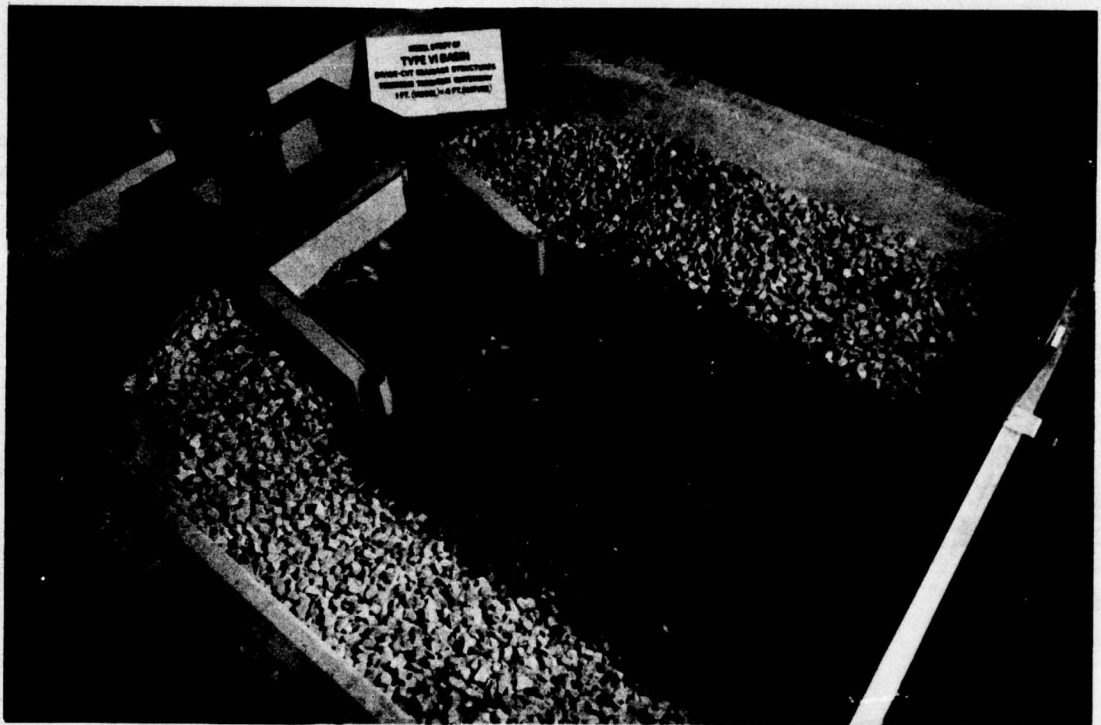

a. Tailwater uncontrolled

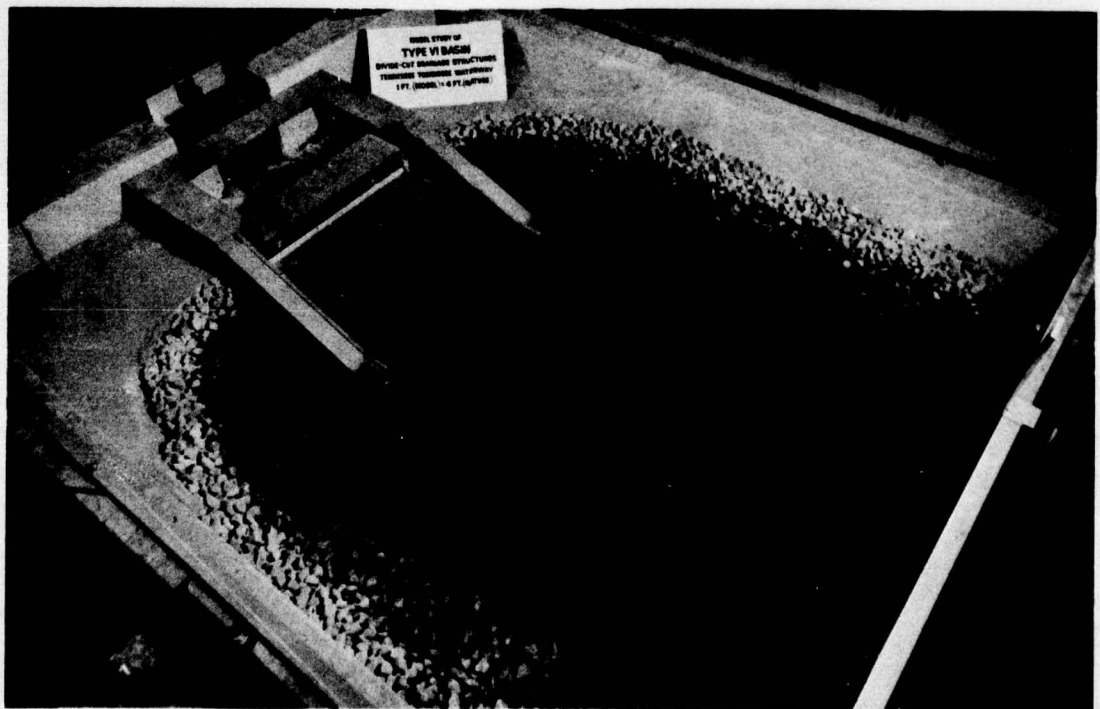

b. Tailwater 4 ft

Photo 2. Flow conditions with original design impact basin; 4-ft-wide chute, discharge 60 cfs

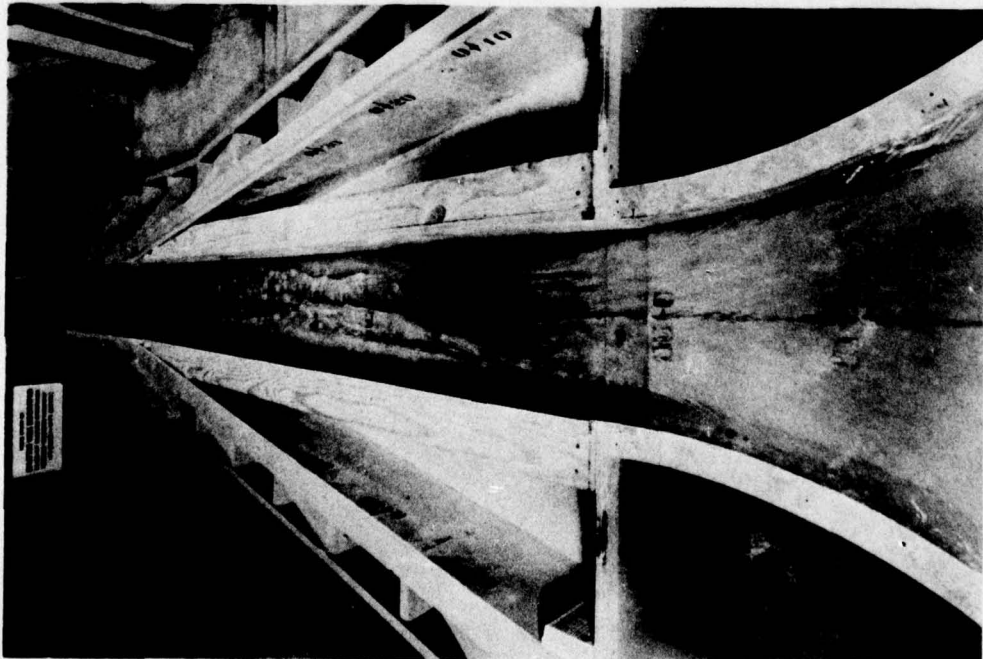

a. Transition and chute to closed conduit

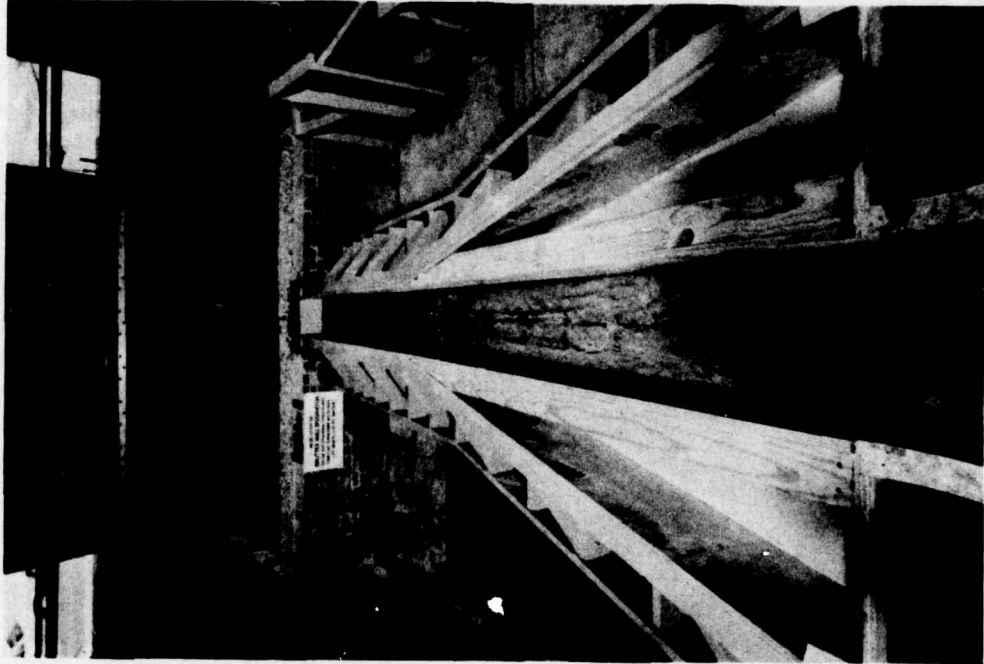

b. Chute, closed conduit, and dissipation  
at splitter-wall dissipator in canal

Photo 3. Flow conditions with type 2 transition; 10-ft-wide chute, design discharge 900 cfs

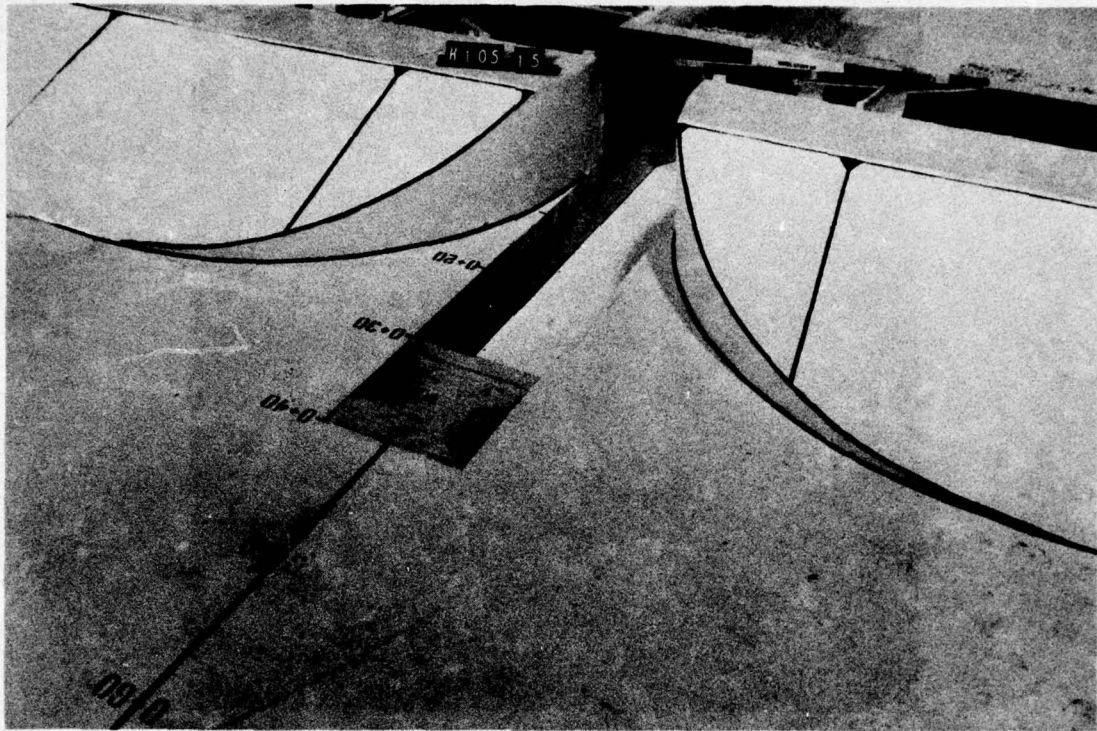

a.  $W = 10$  ft,  $B = 3W$ ,  $D = 0.6W$

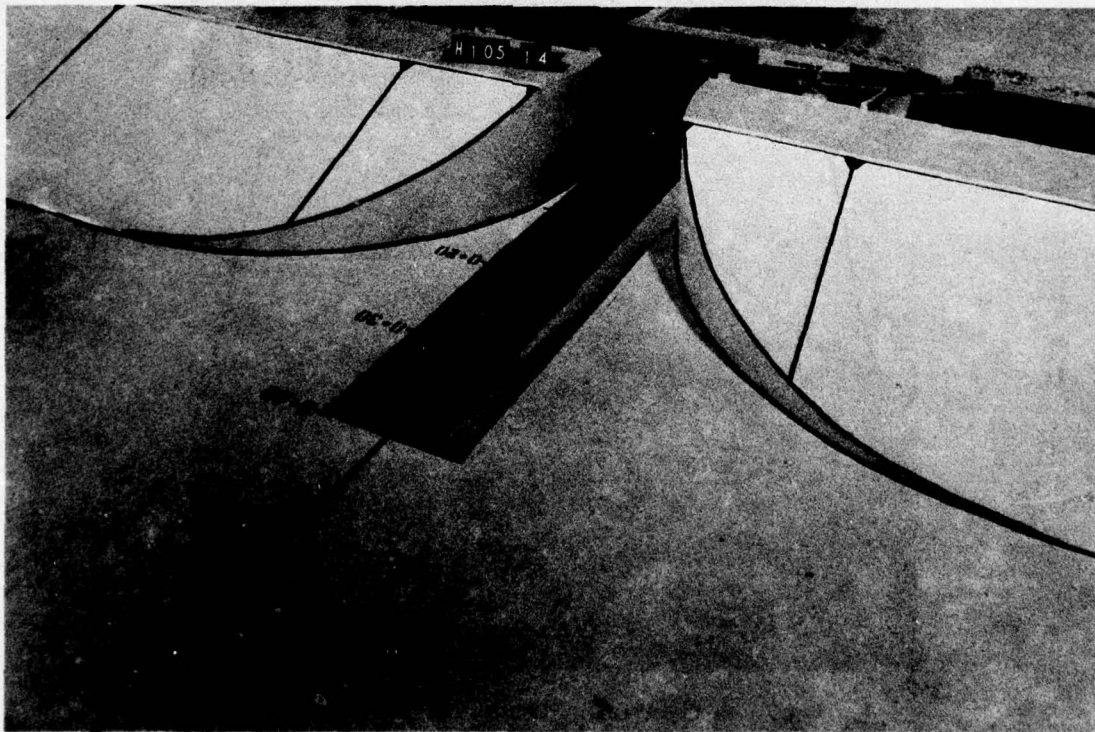

b.  $W = 10$  ft,  $B = 4W$ ,  $D = W$

Photo 4. Type 6 drop structure and transitions

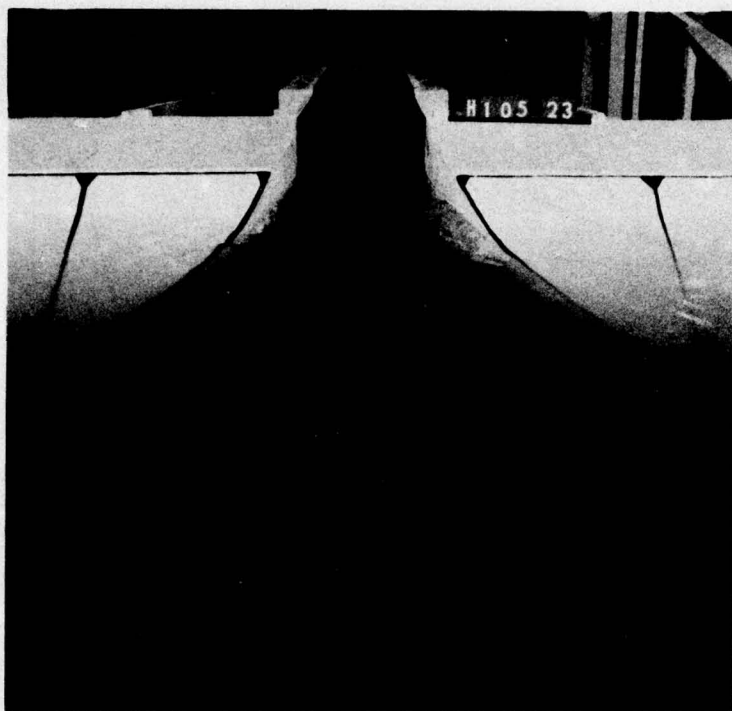

a. No drop, discharge 900 cfs

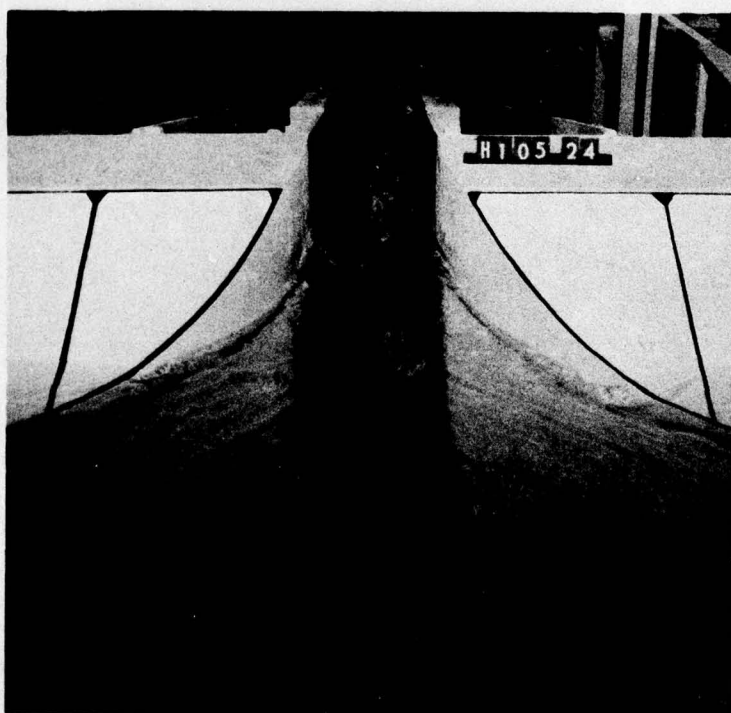

b. 6-ft-drop, discharge 900 cfs

Photo 5. Flow conditions in type 6 drop structure with a  
10-ft-wide chute (sheet 1 of 2)

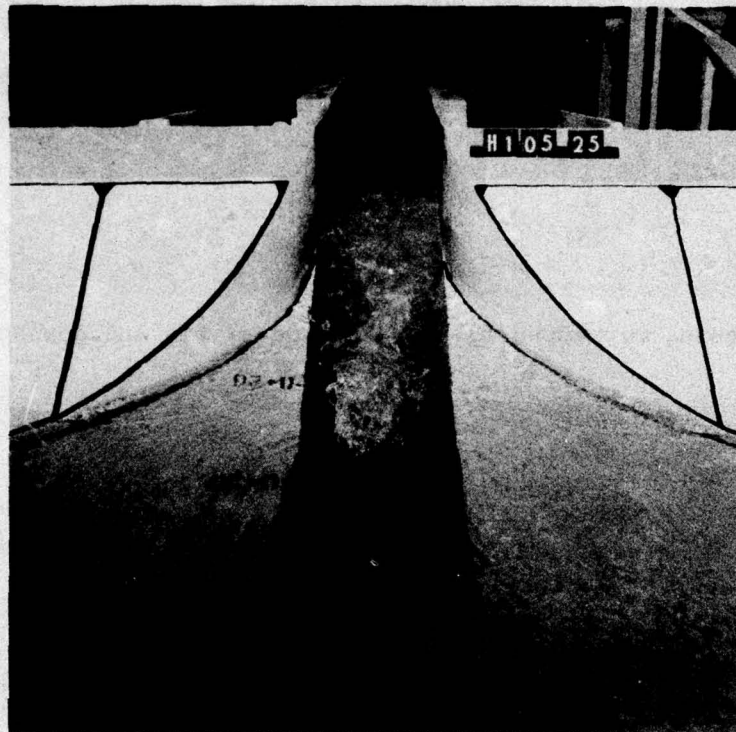

c. 6-ft-drop, discharge 500 cfs

Photo 5. (sheet 2 of 2)

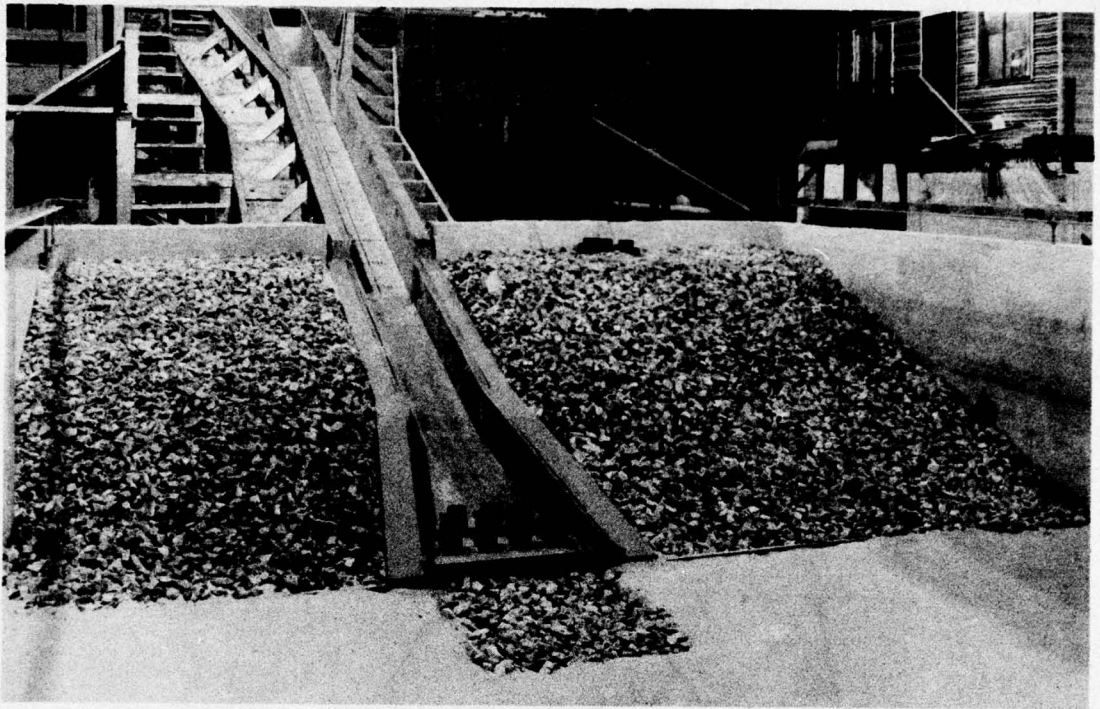

a. Before tests, riprapped IV-on-2.5H side slopes and downstream riprap blanket

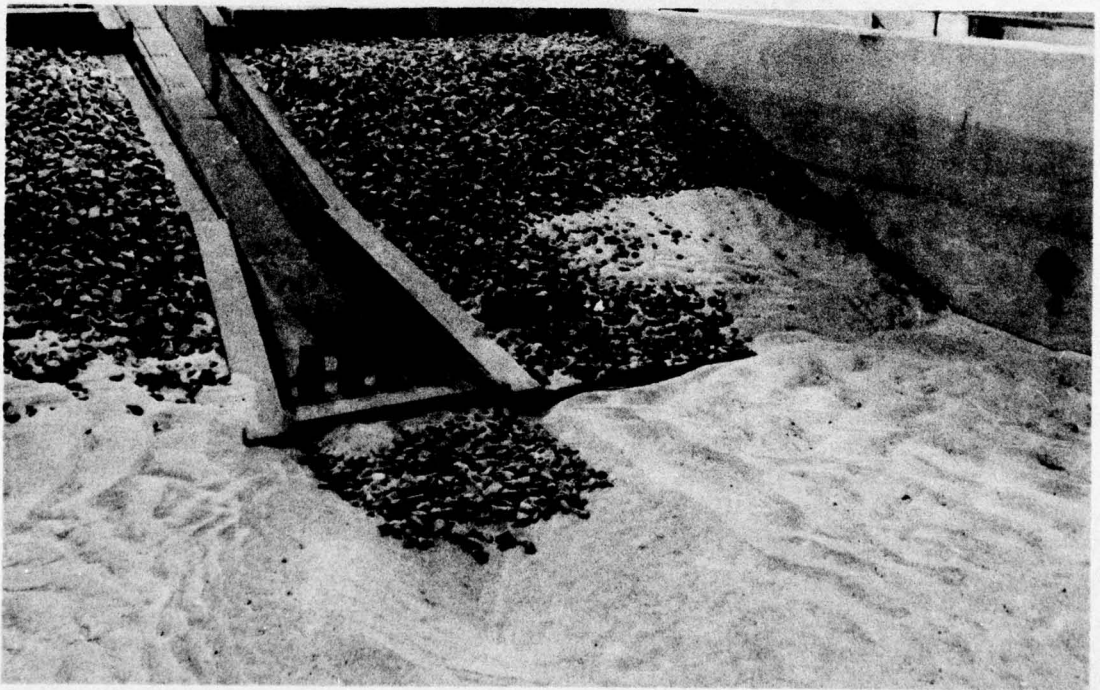

b. Scour after 1-hr operation at design discharge of 900 cfs, with downstream riprap blanket

Photo 6. Type 6 drop structure and type 18 energy dissipator  
(sheet 1 of 2)

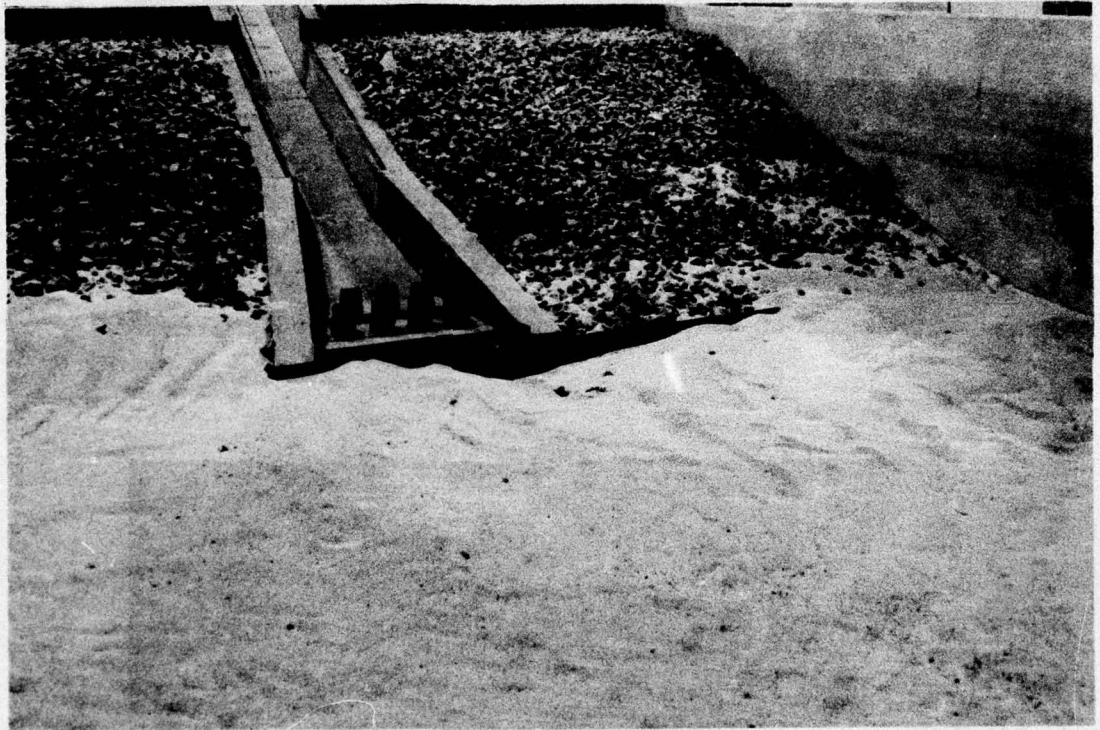

c. Scour after 1-hr operation at design discharge of 900 cfs, with no riprap

Photo 6. (sheet 2 of 2)

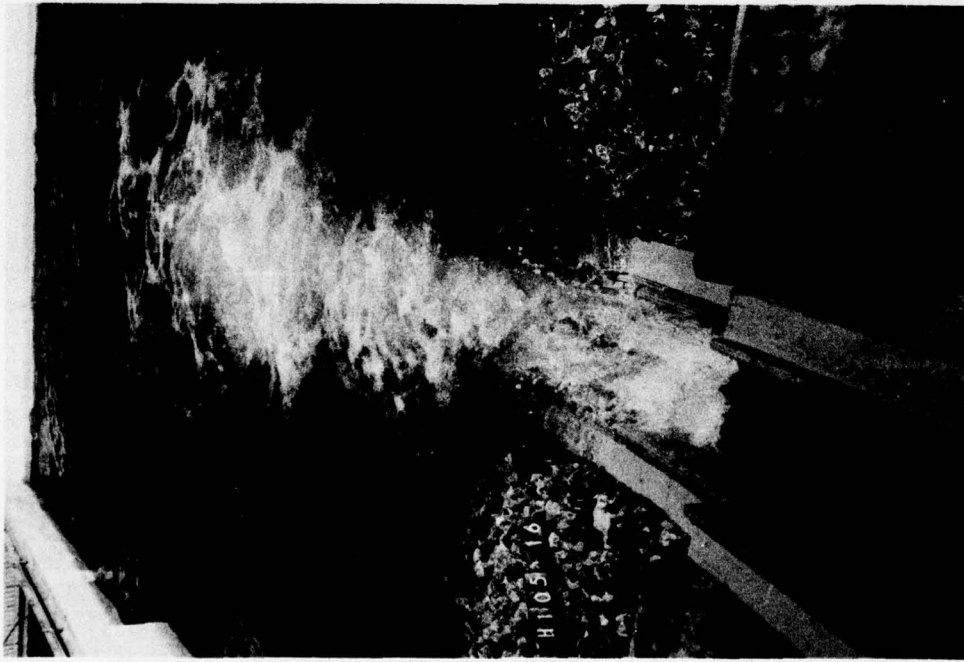

a. Canal stage 418 (maximum)

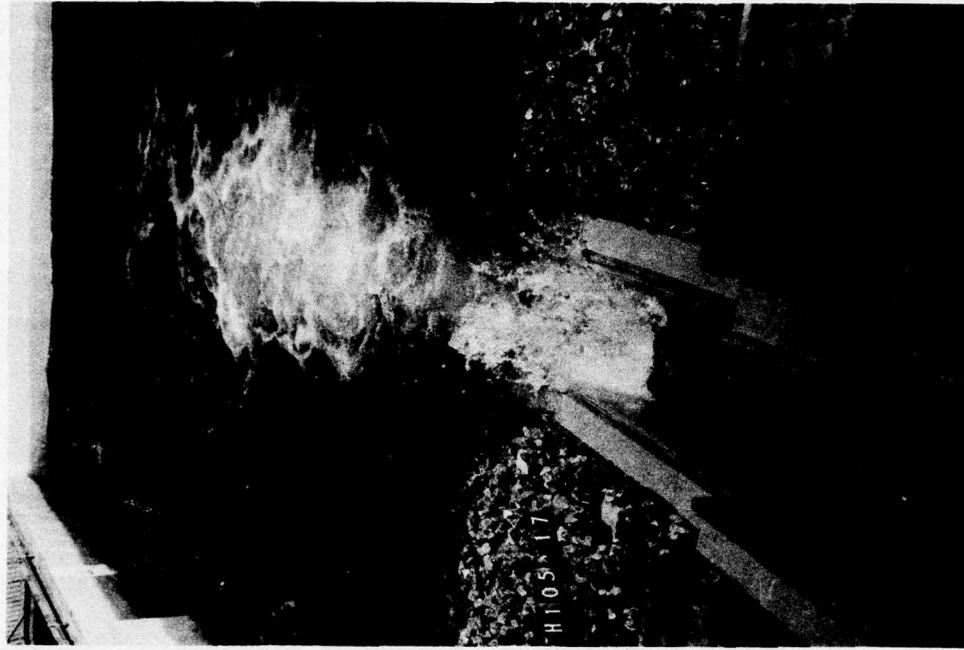

b. Canal stage 414 (normal)

Photo 7. Flow conditions with type 18 energy dissipator, discharge 900 cfs (sheet 1 of 2)



c. Canal stage 408 (minimum)

Photo 7. (sheet 2 of 2)

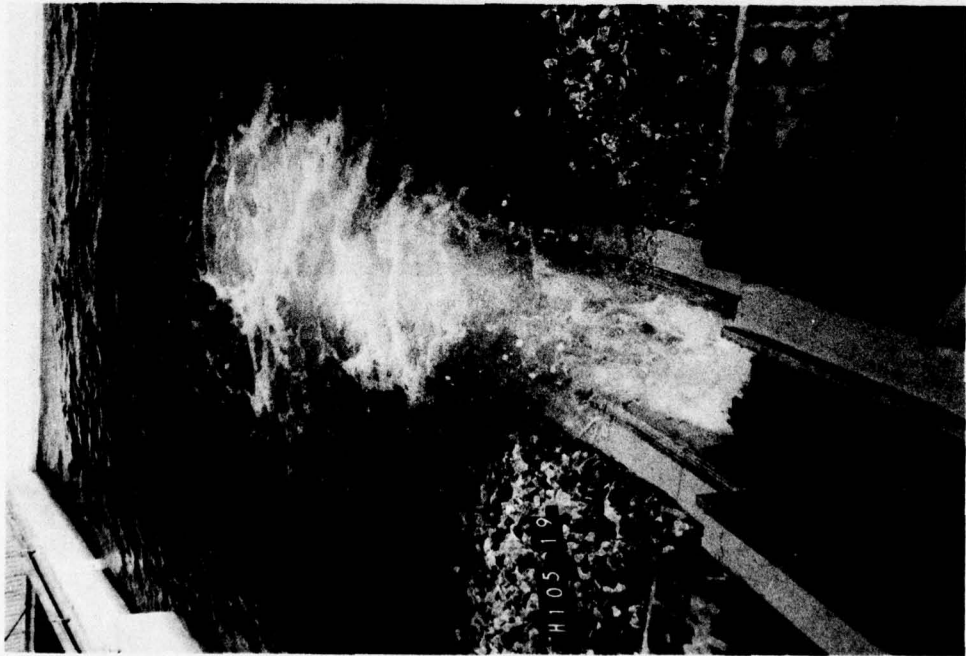

a. Canal stage 418 (maximum)



b. Canal stage 414 (normal)

Photo 8. Flow conditions with type 18 energy dissipator, discharge 500 cfs (sheet 1 of 2)

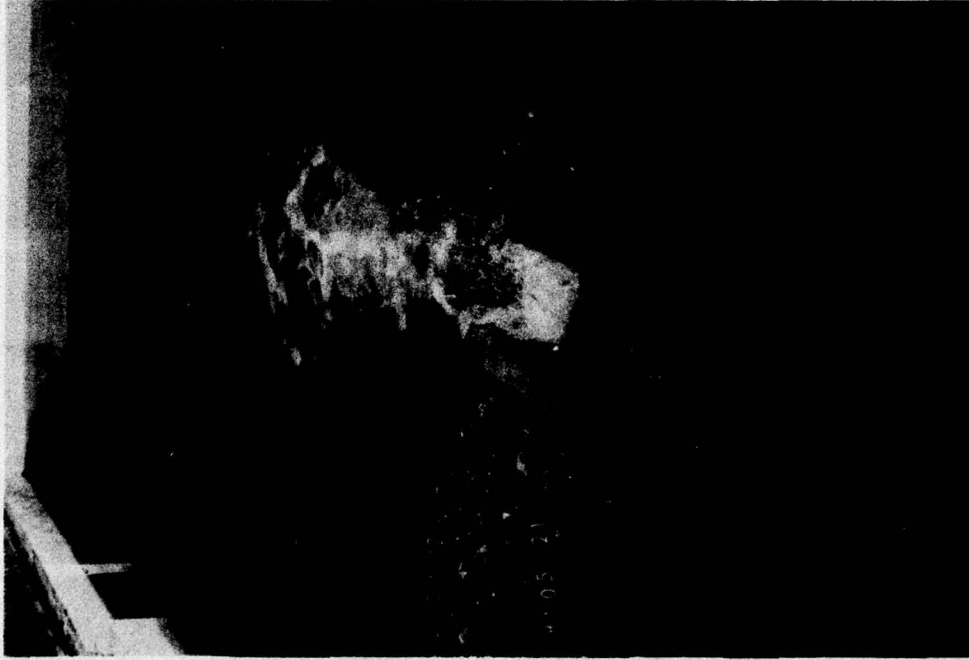

c. Canal stage 408 (minimum)

Photo 8. (sheet 2 of 2)

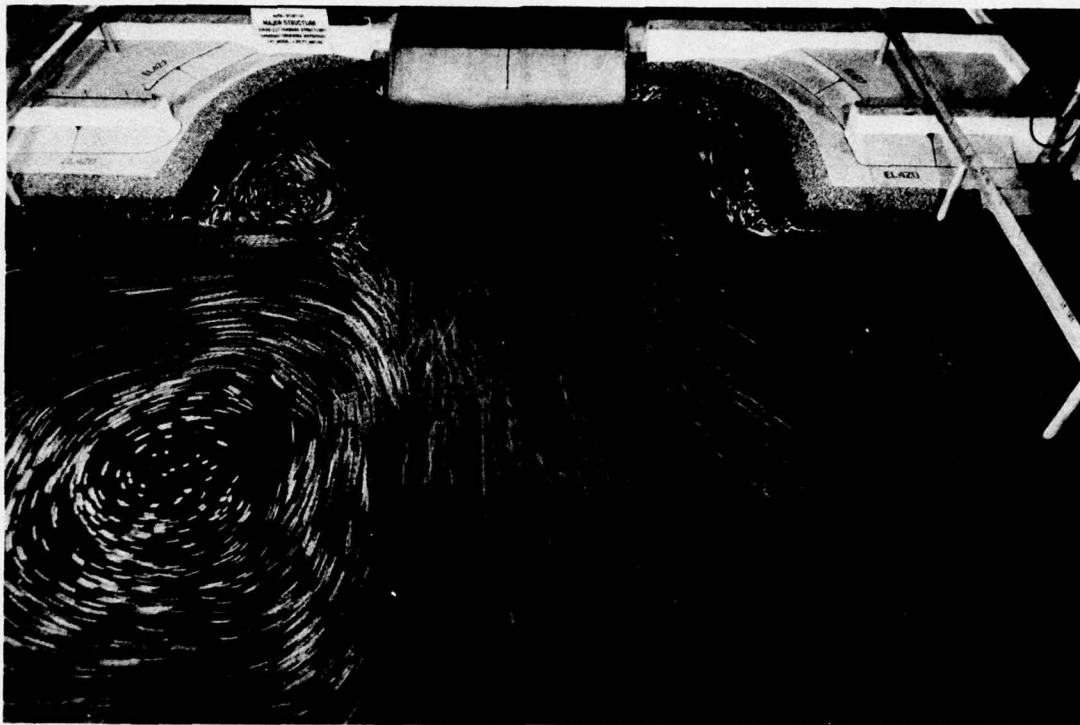

Photo 9. Flow conditions in type 4 stilling basin, discharge 9700 cfs

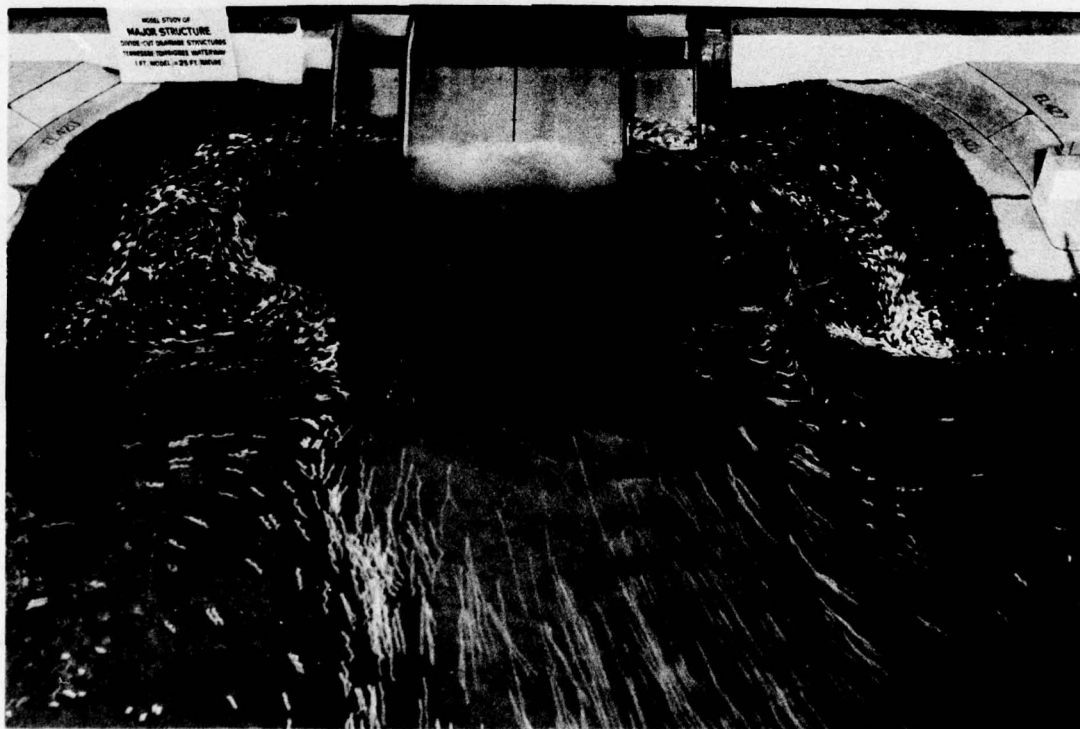

Photo 10. Flow conditions in type 10 stilling basin, discharge 9700 cfs

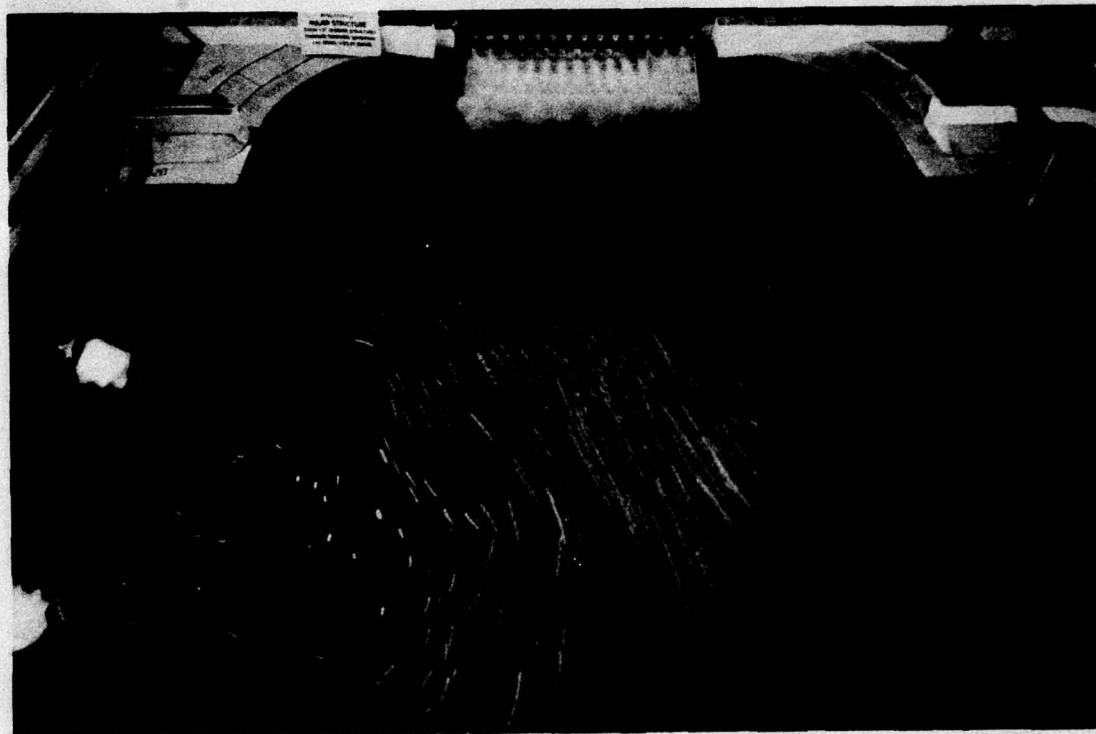
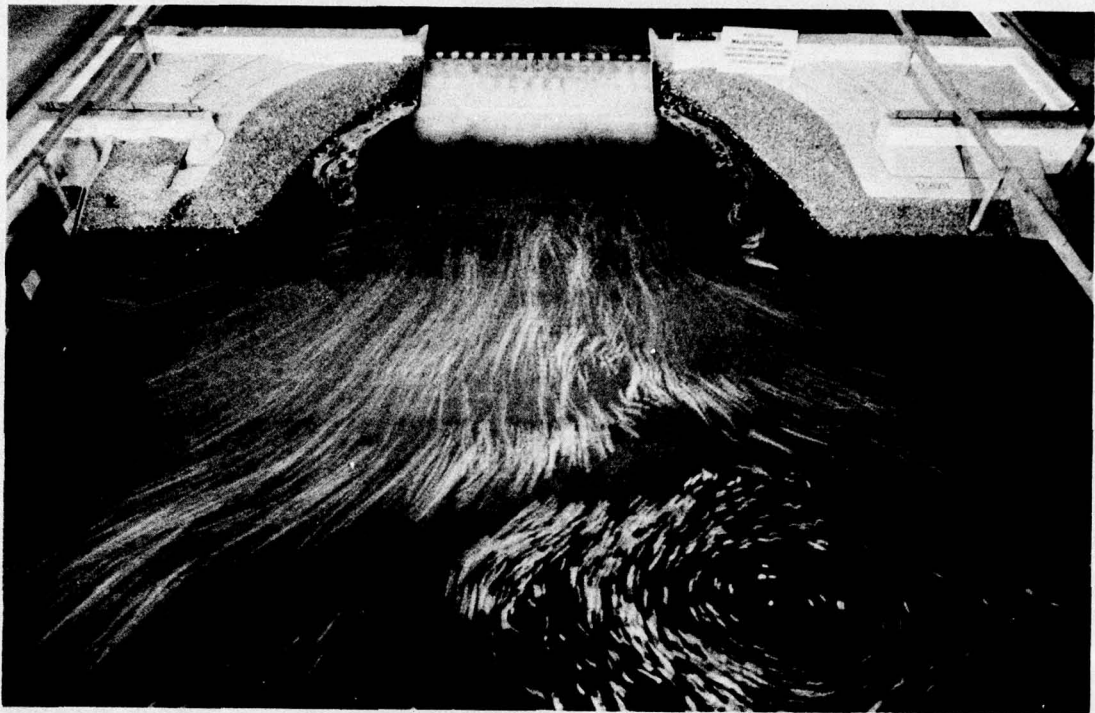

Photo 11. Flow conditions in type 14 structure, discharge 9700 cfs



a. Flow divided upstream and downstream



b. All flow downstream

Photo 12. Flow conditions in type 15 (recommended) structure,  
discharge 9700 cfs

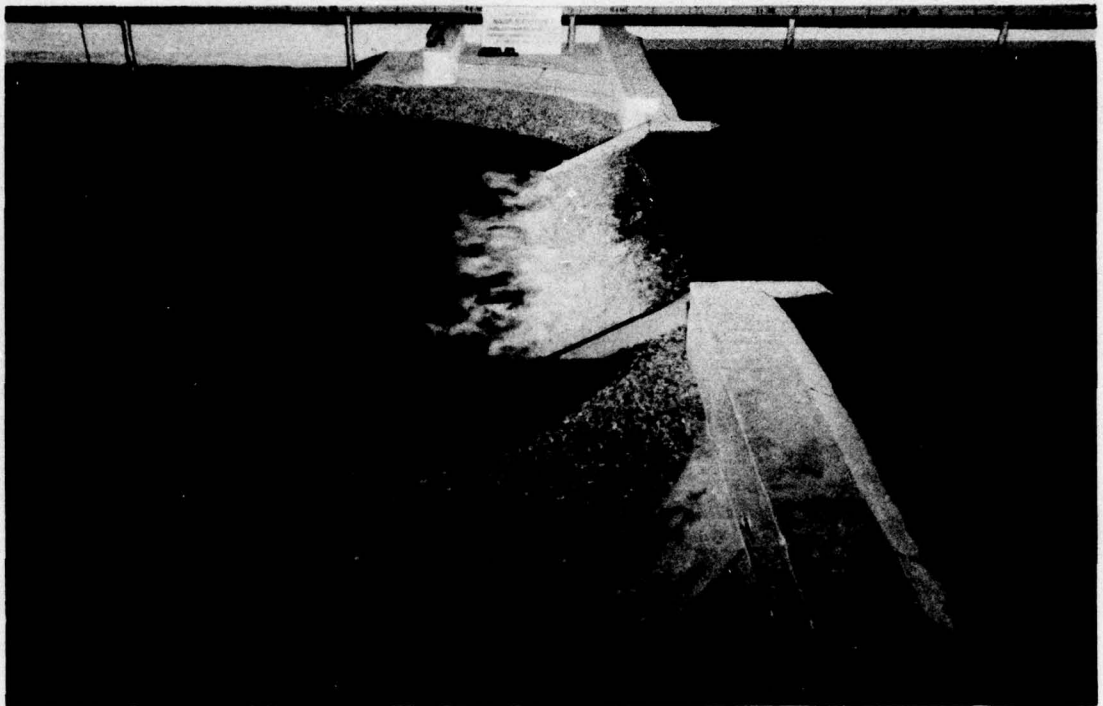

a. Canal stage 408 (minimum)

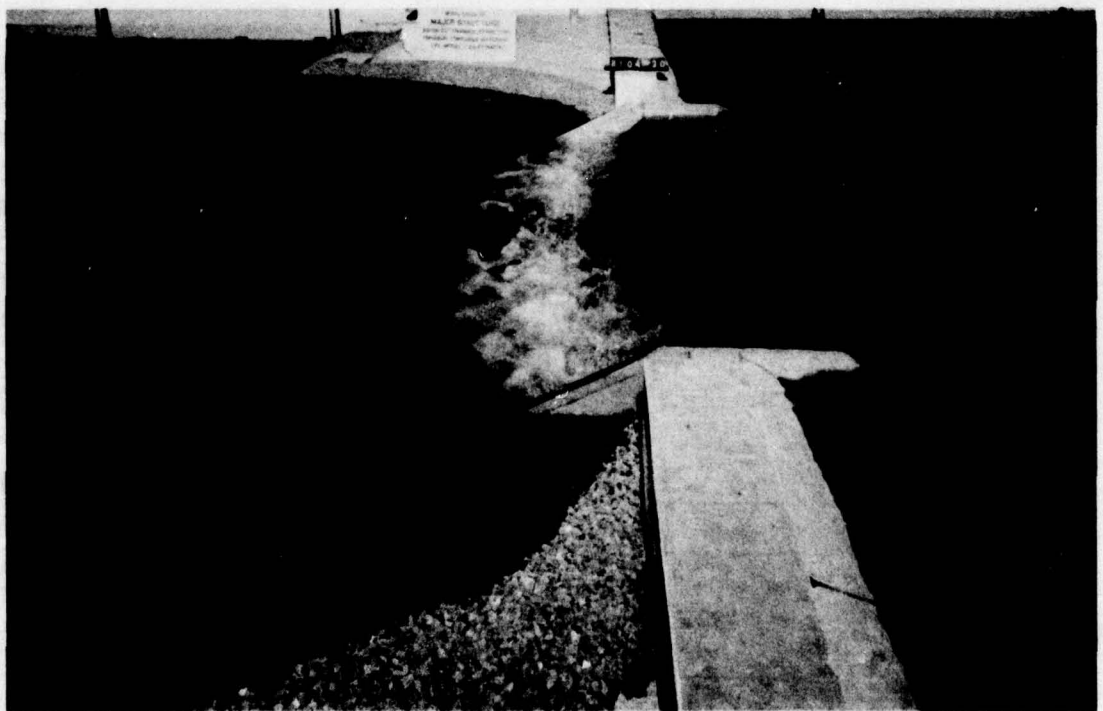

b. Canal stage 418 (maximum)

Photo 13. Flow conditions in type 15 structure with flared stilling pool abutments, discharge 9700 cfs



a. Canal stage 408 (minimum)

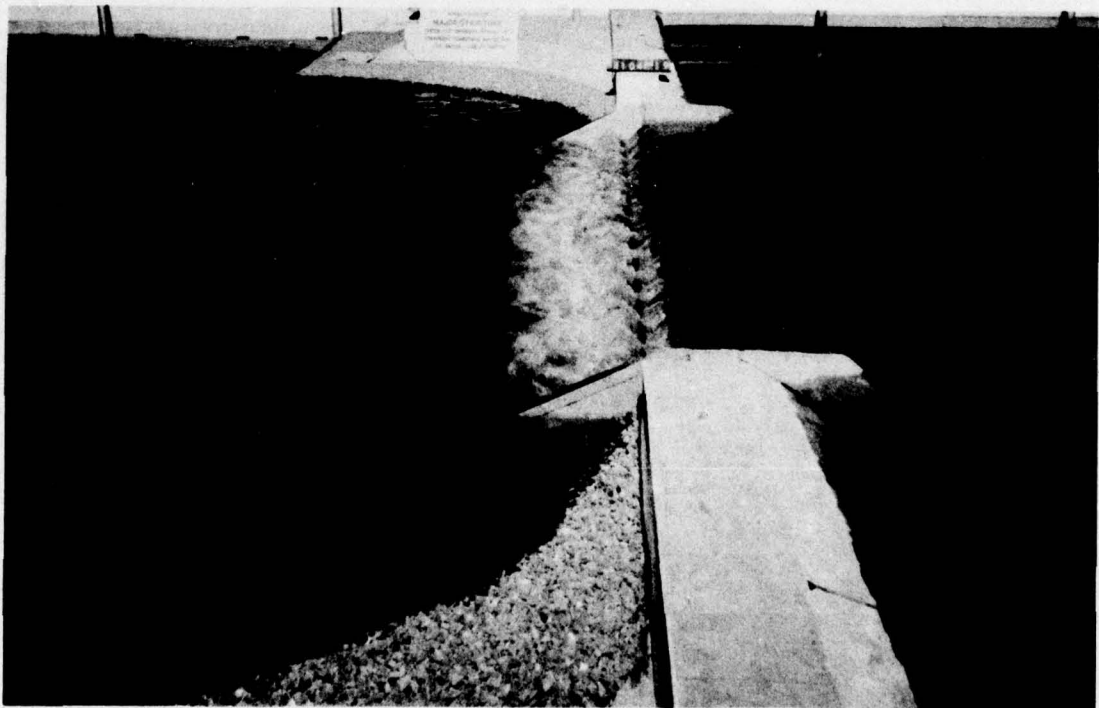

b. Canal stage 418 (maximum)

Photo 14. Flow conditions in type 15 structure with flared stilling pool abutments, discharge 5000 cfs

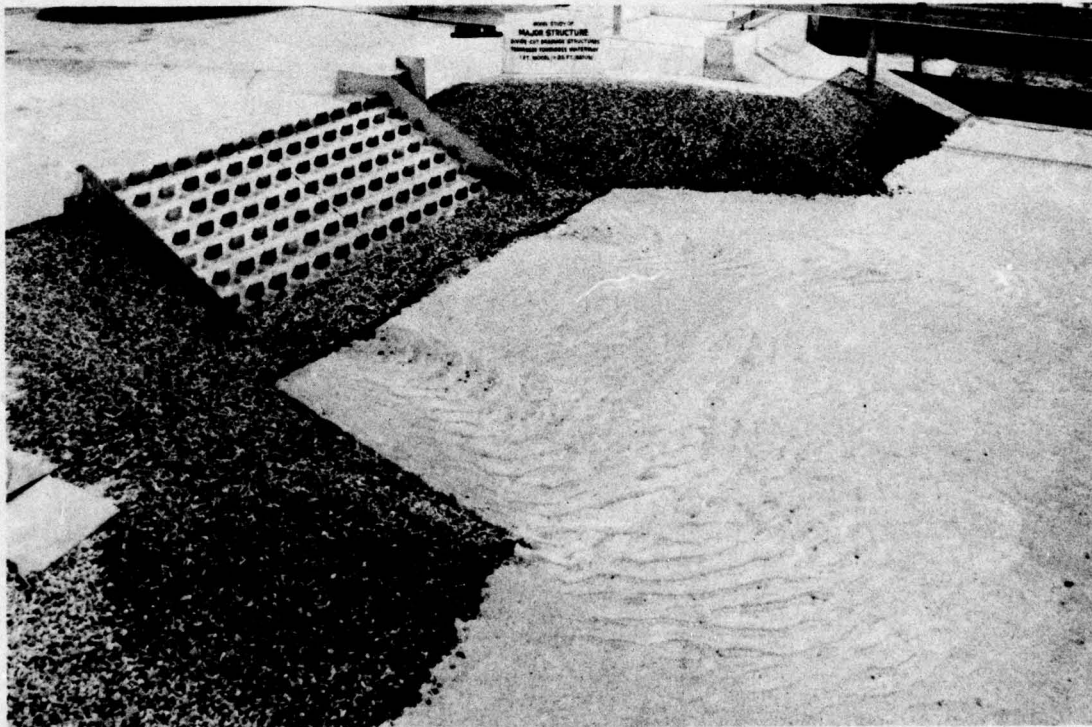
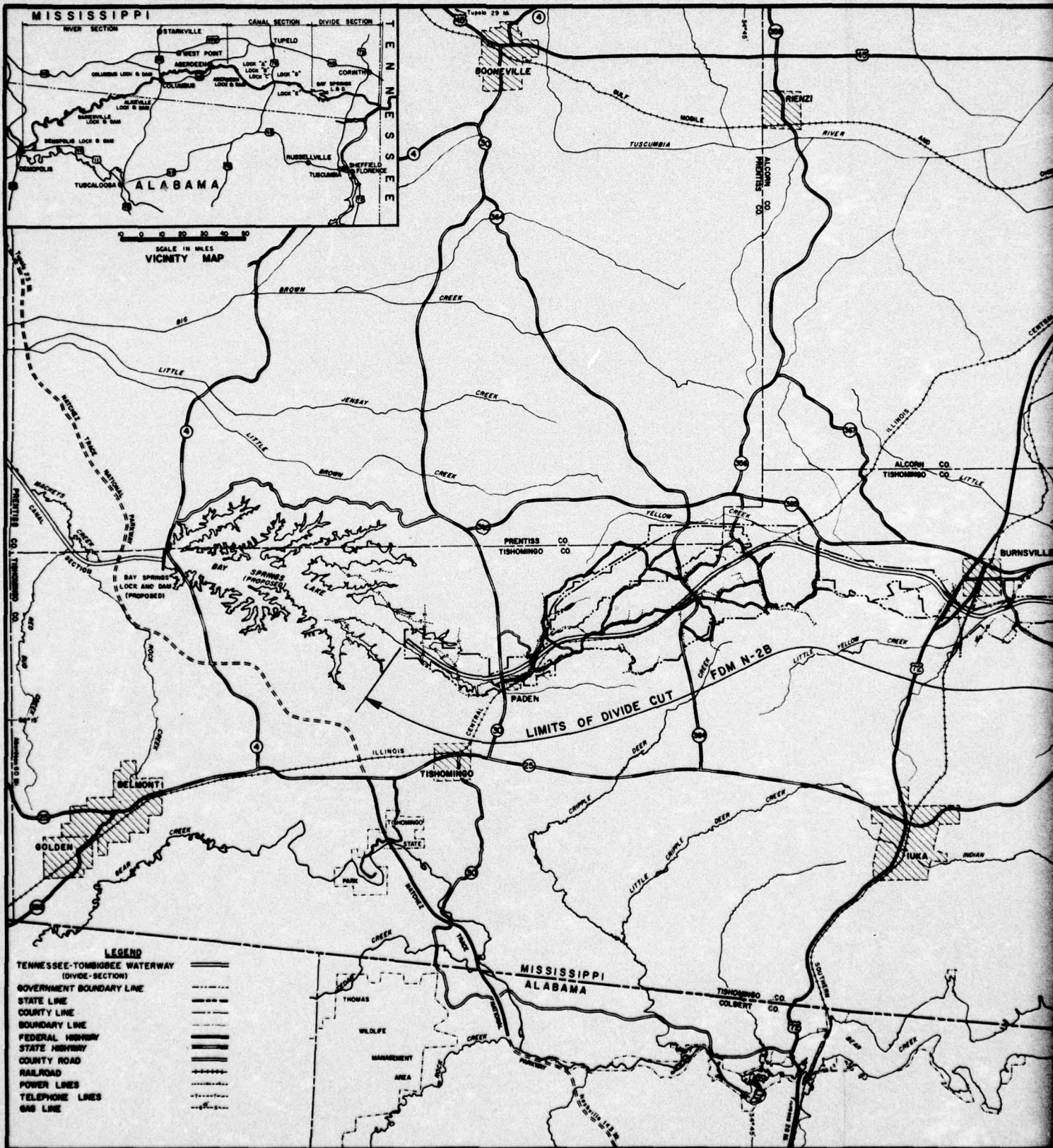
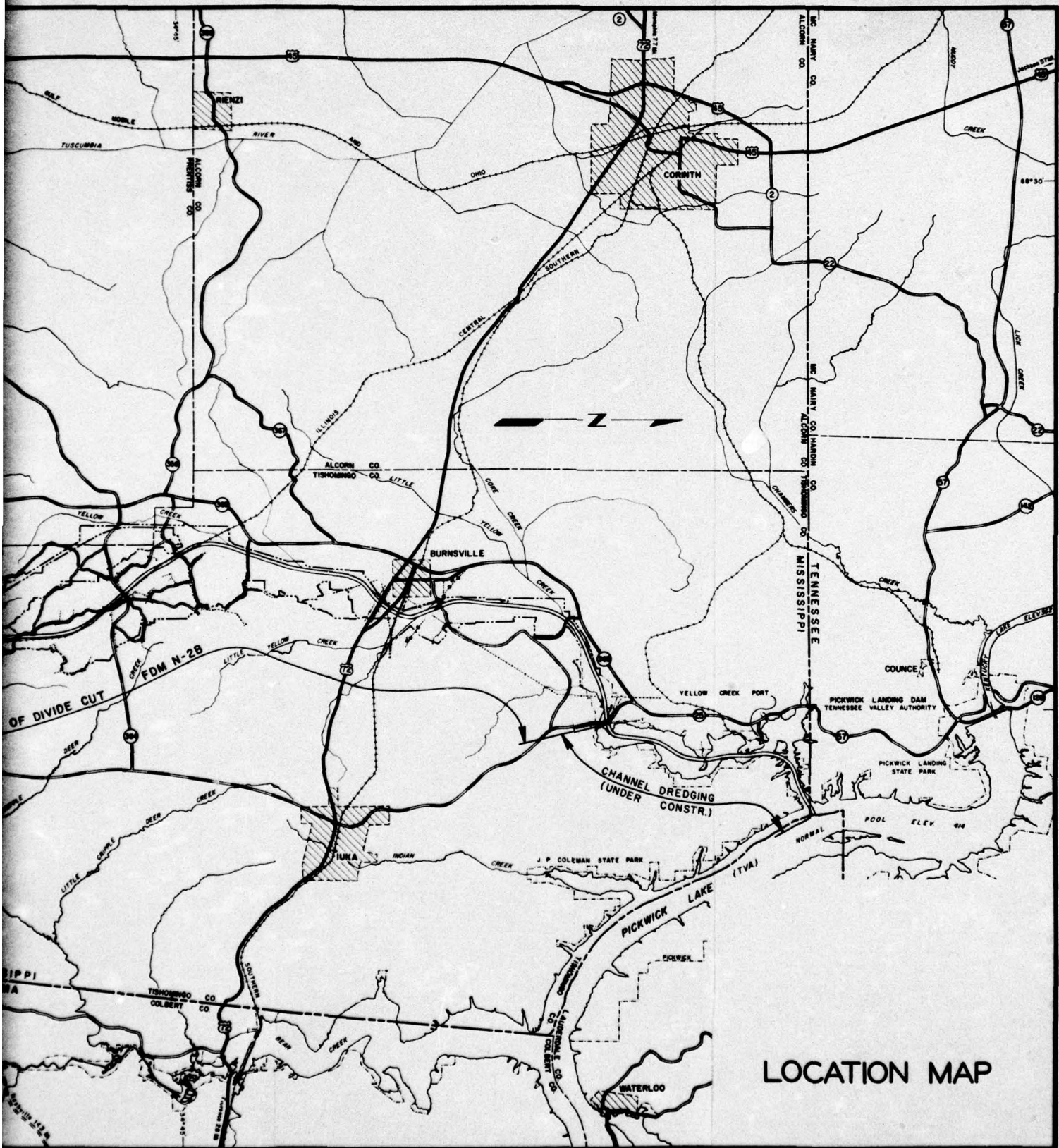

Photo 15. Scour downstream of type 15 structure after 5-hr operation at design discharge 9700 cfs and canal stage 408 (minimum)





LOCATION MAP

2

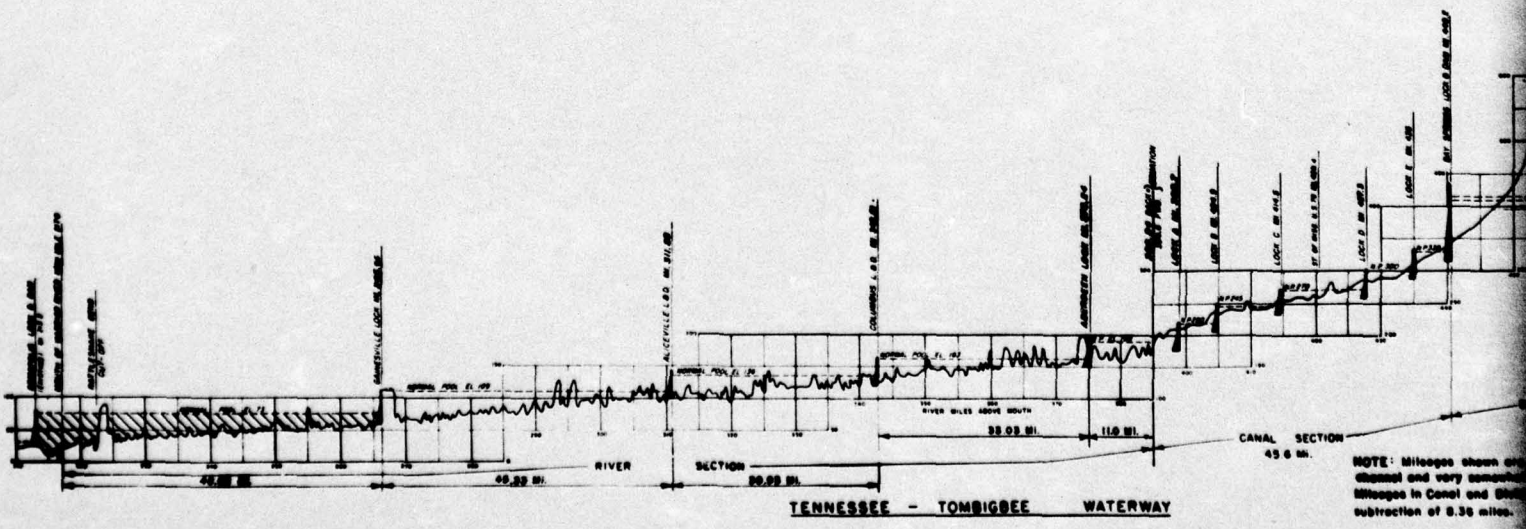
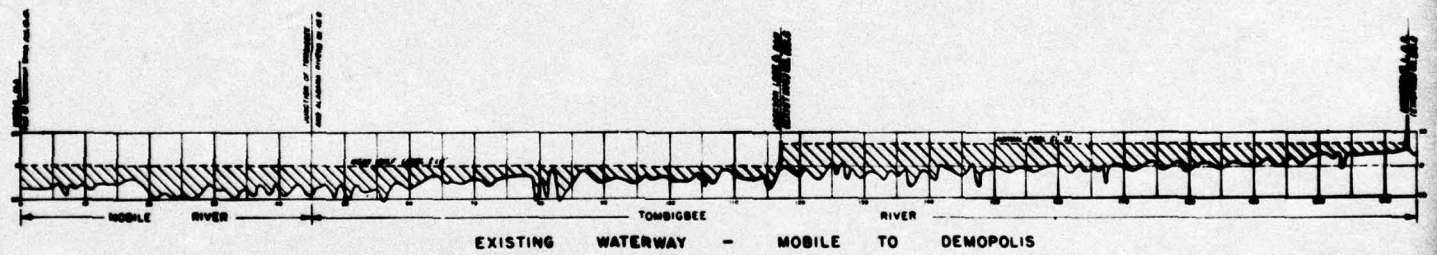
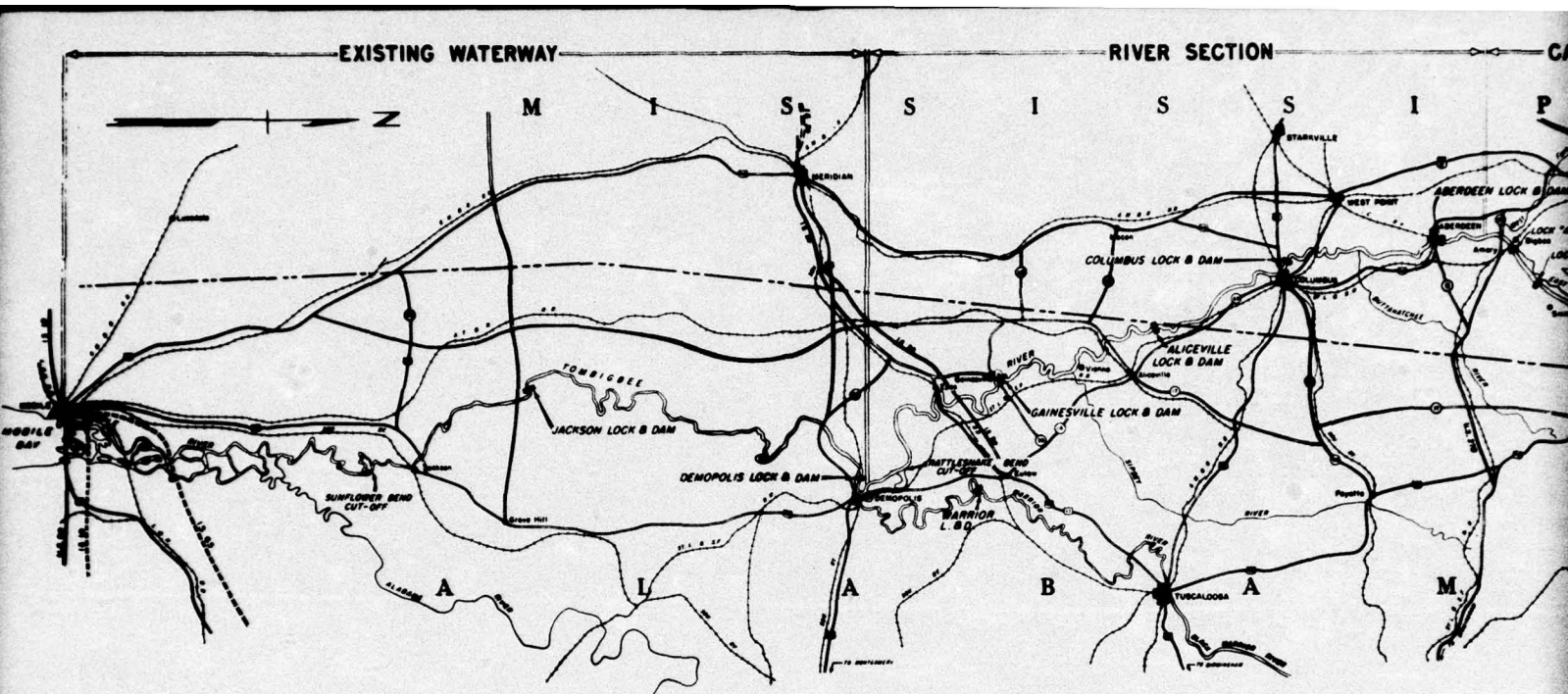

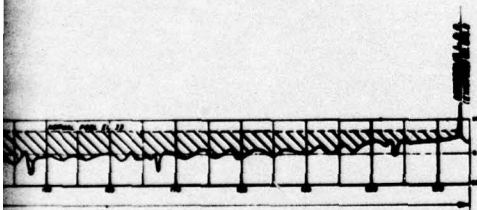
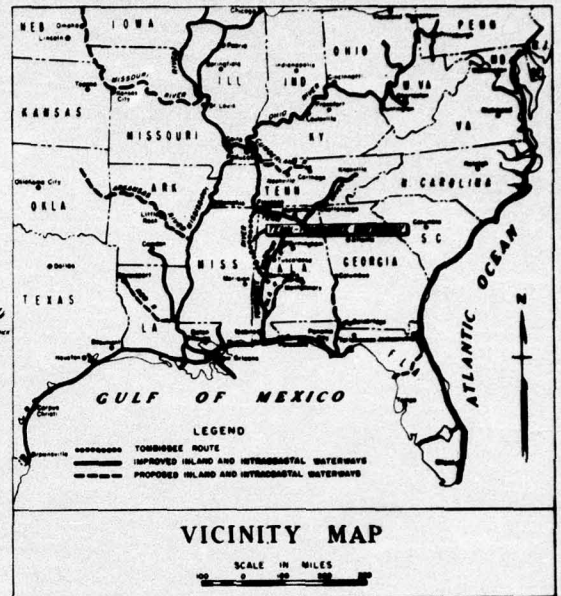
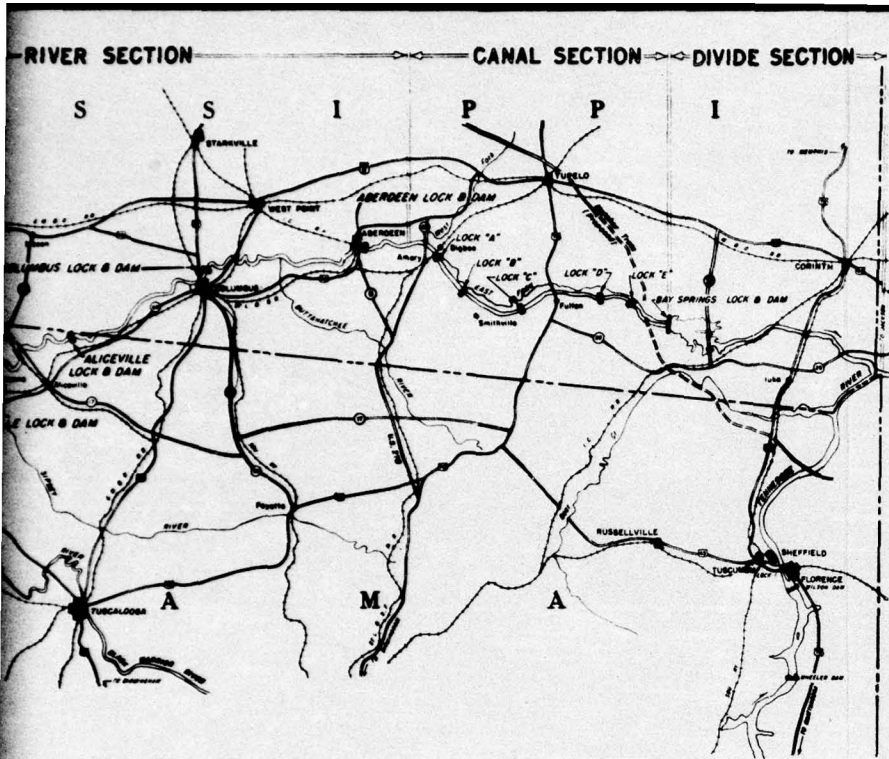

EMOPOLIS

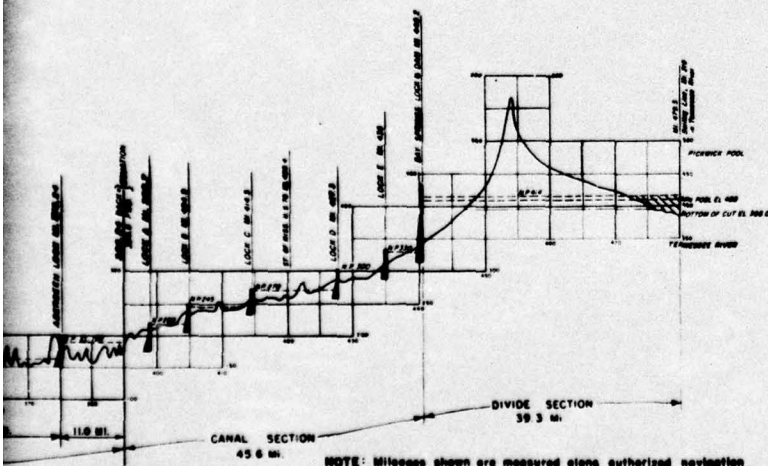

NOTE: Mileages shown are measured along authorized navigation channel and vary somewhat from those shown in previous documents. Mileages in Canal and Divide Sections are subject to correction by subtraction of 0.36 miles.

**LEGEND**

- LOCK AND DAM, EXISTING OR UNDER CONSTRUCTION
- PROPOSED LOCK AND DAM

**GENERAL PLAN AND PROFILE**

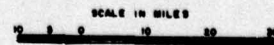

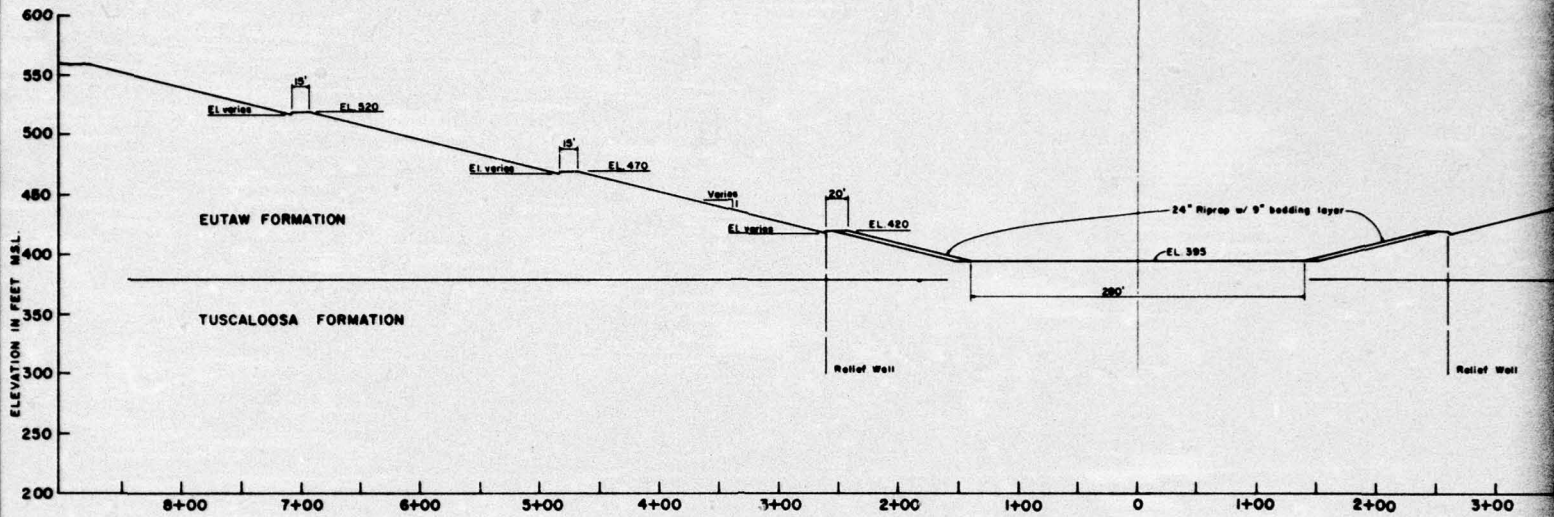

TYPICAL SECTION  
BETWEEN STA. 12,120+00 AND  
STA. 13,150+00

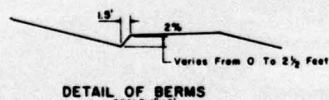

DETAIL OF BERMS  
SCALE 1"=10'

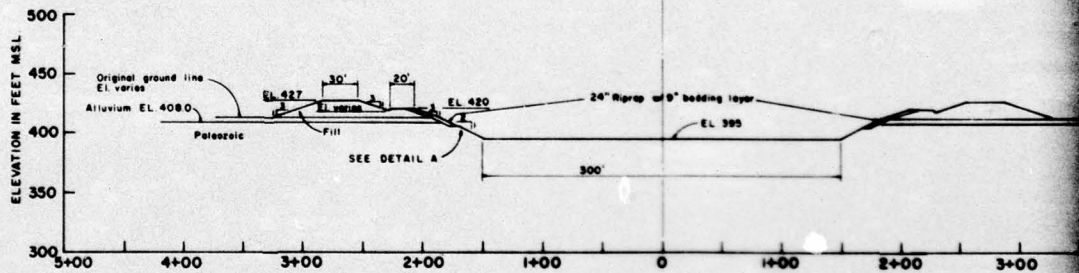

TYPICAL SECTION  
BETWEEN STA. 13,150+00 AND  
STA. 13,337+50

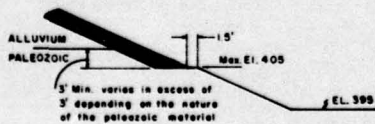

DETAIL A  
Scale: 1"=10'

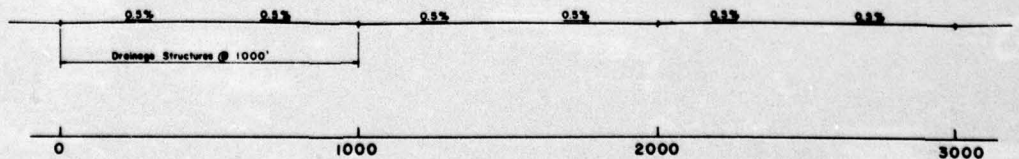

PROFILE OF DRAINAGE DITCH  
ON BERMS

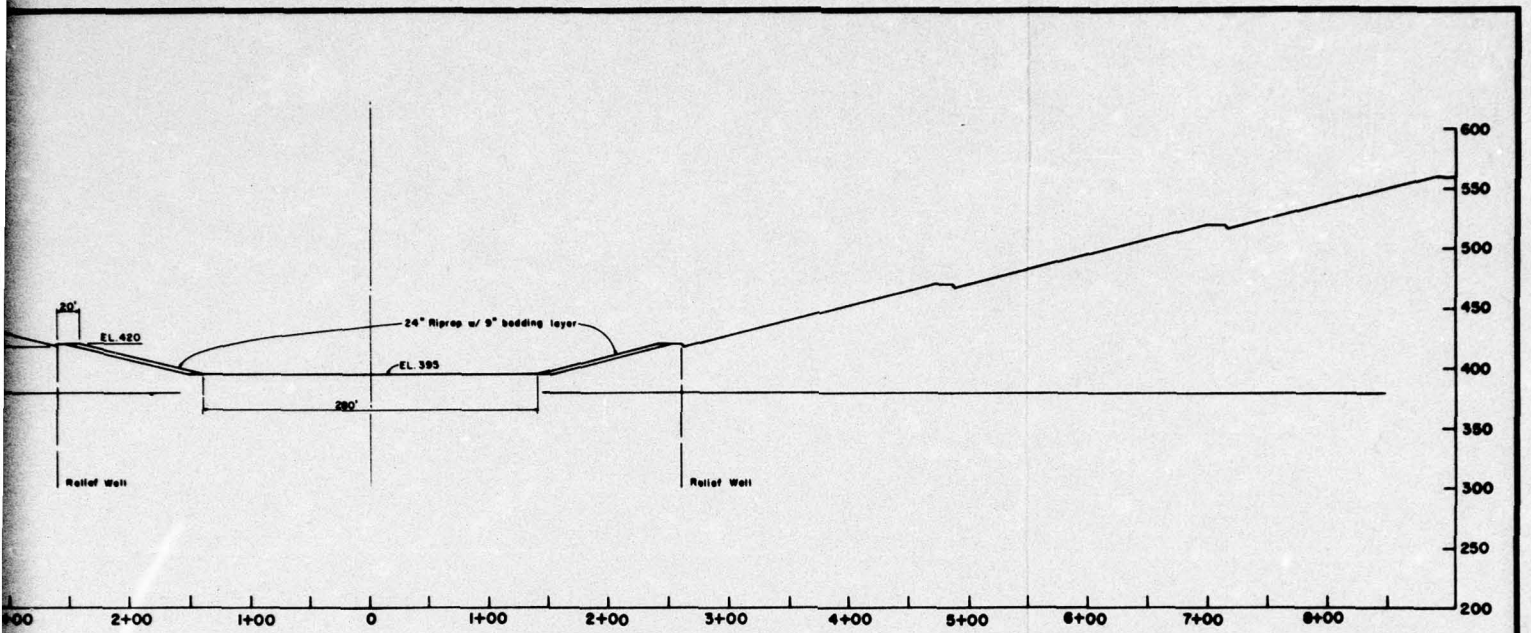

TYPICAL SECTION  
 BETWEEN STA. 12,120+00 AND  
 STA. 13,150+00

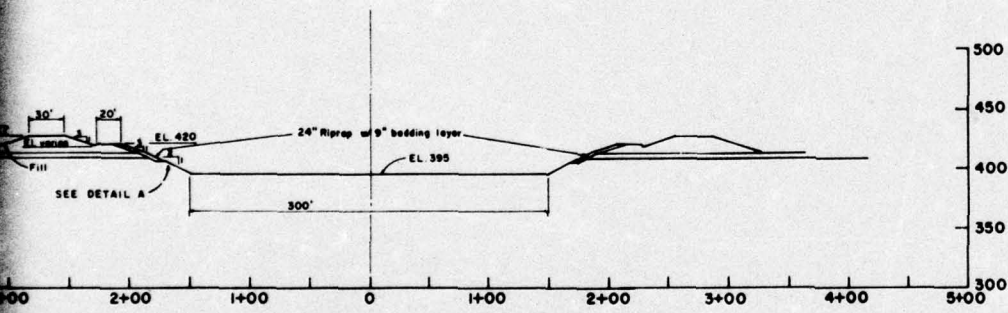

TYPICAL SECTION  
 BETWEEN STA. 13,150+00 AND  
 STA. 13,337+50

NOTE:  
 1. These sections are symmetrical about the center line.  
 2. SEE GDM N-1 For discussion on slope materials  
 and slope dimensions.

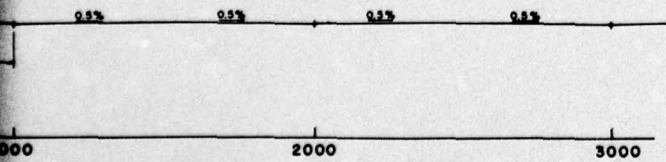

PROFILE OF DRAINAGE DITCH  
 ON BERMS

## TYPICAL SECTIONS

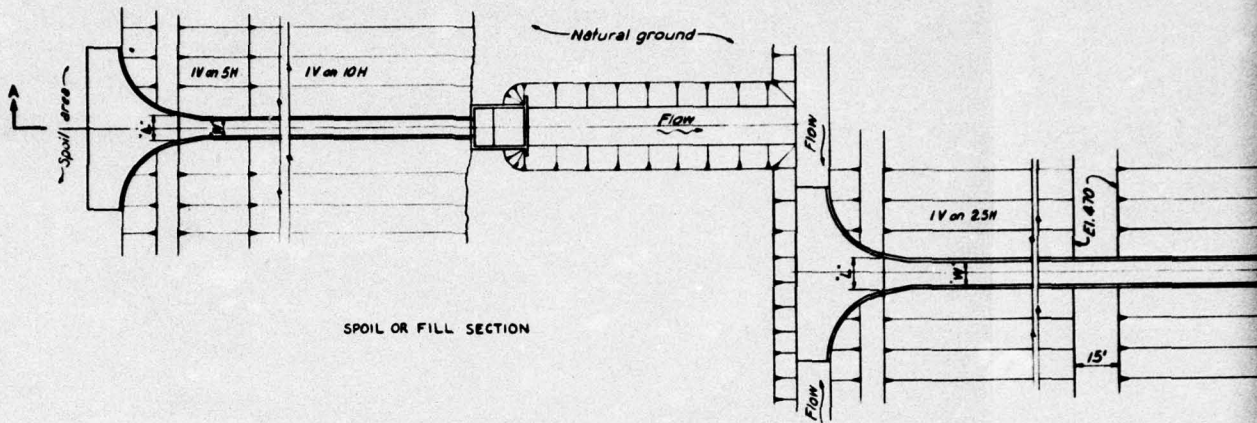

SPOIL OR FILL SECTION

PLAN  
SCALE 1" = 20'

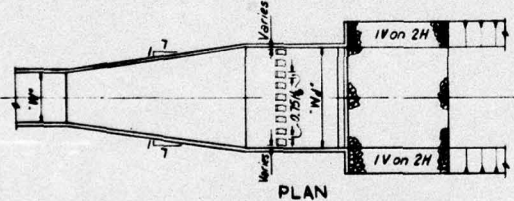
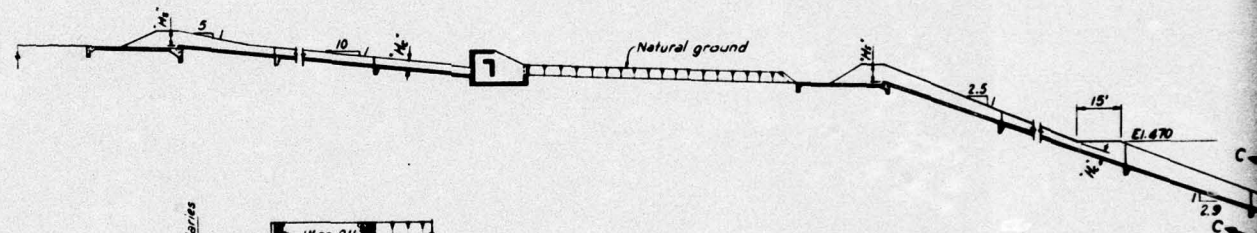

PLAN

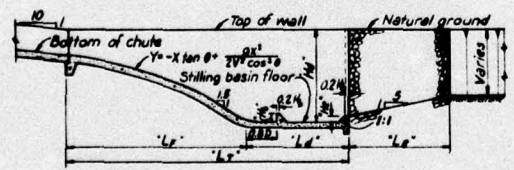

TYPICAL SECTION  
APRON TYPE

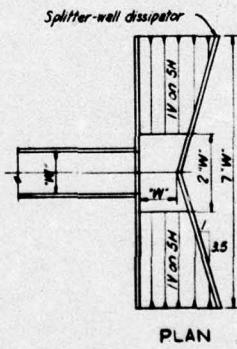

PLAN

SECTION A-A  
SCALE 1" = 20'

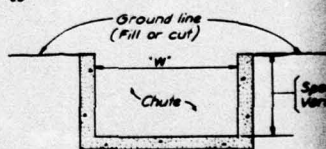

SECTION C-C

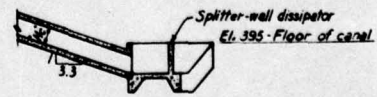

TYPICAL SECTION  
IMPACT TYPE  
ENERGY DISSIPATOR  
CUT SECTION

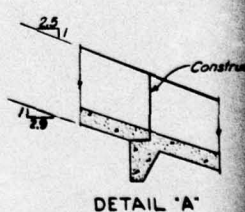

DETAIL 'A'

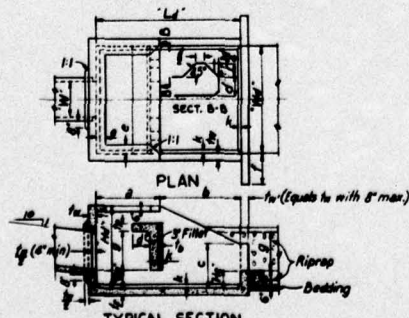

TYPICAL SECTION  
IMPACT TYPE  
ENERGY DISSIPATORS  
FILL SECTION

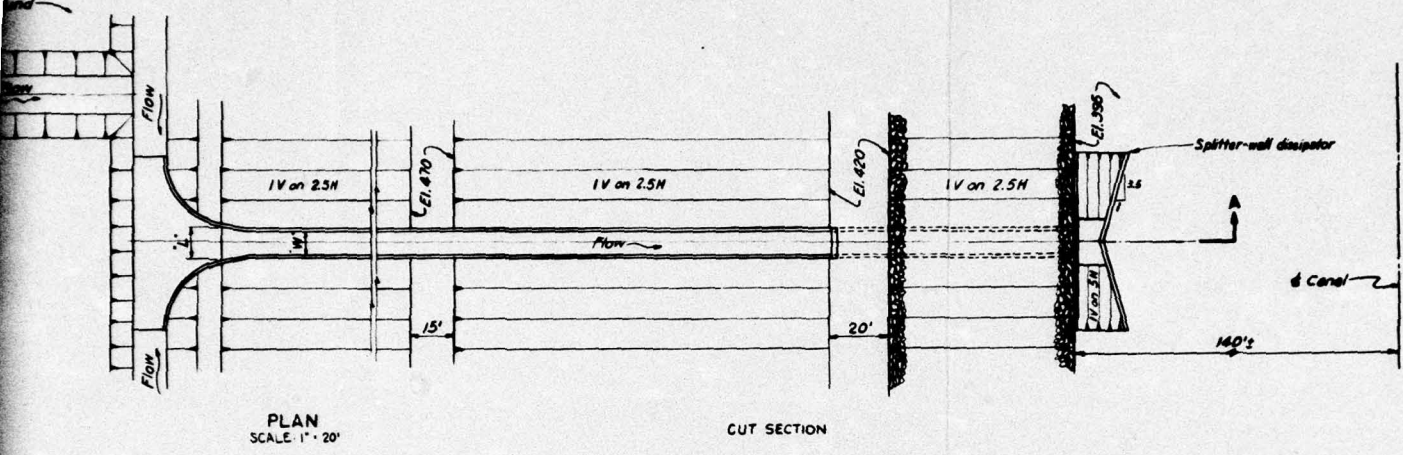

PLAN  
SCALE: 1" = 20'

CUT SECTION

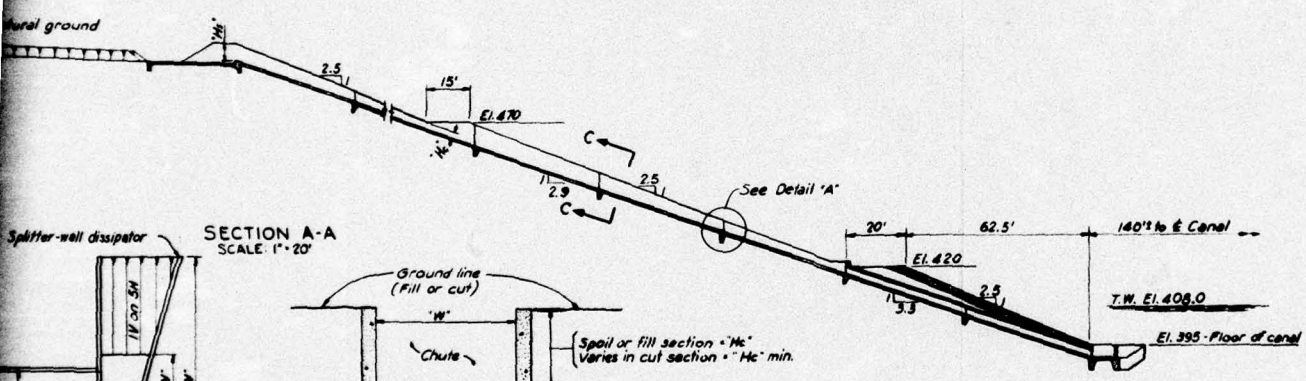

SECTION A-A  
SCALE: 1" = 20'

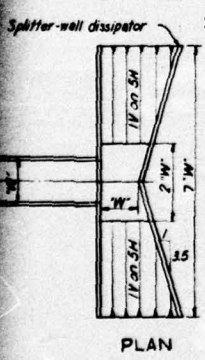

PLAN

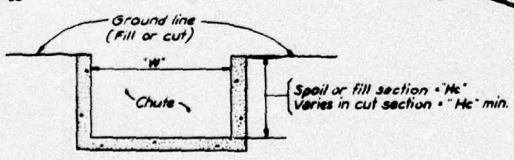

SECTION C-C

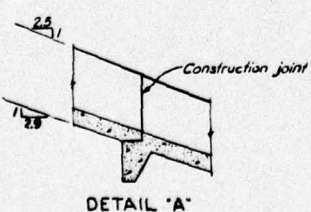

DETAIL 'A'

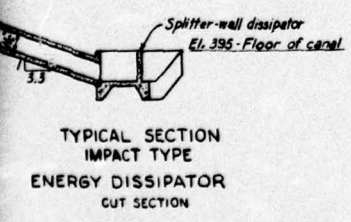

TYPICAL SECTION  
IMPACT TYPE  
ENERGY DISSIPATOR  
CUT SECTION

# MINOR DRAINAGE STRUCTURES

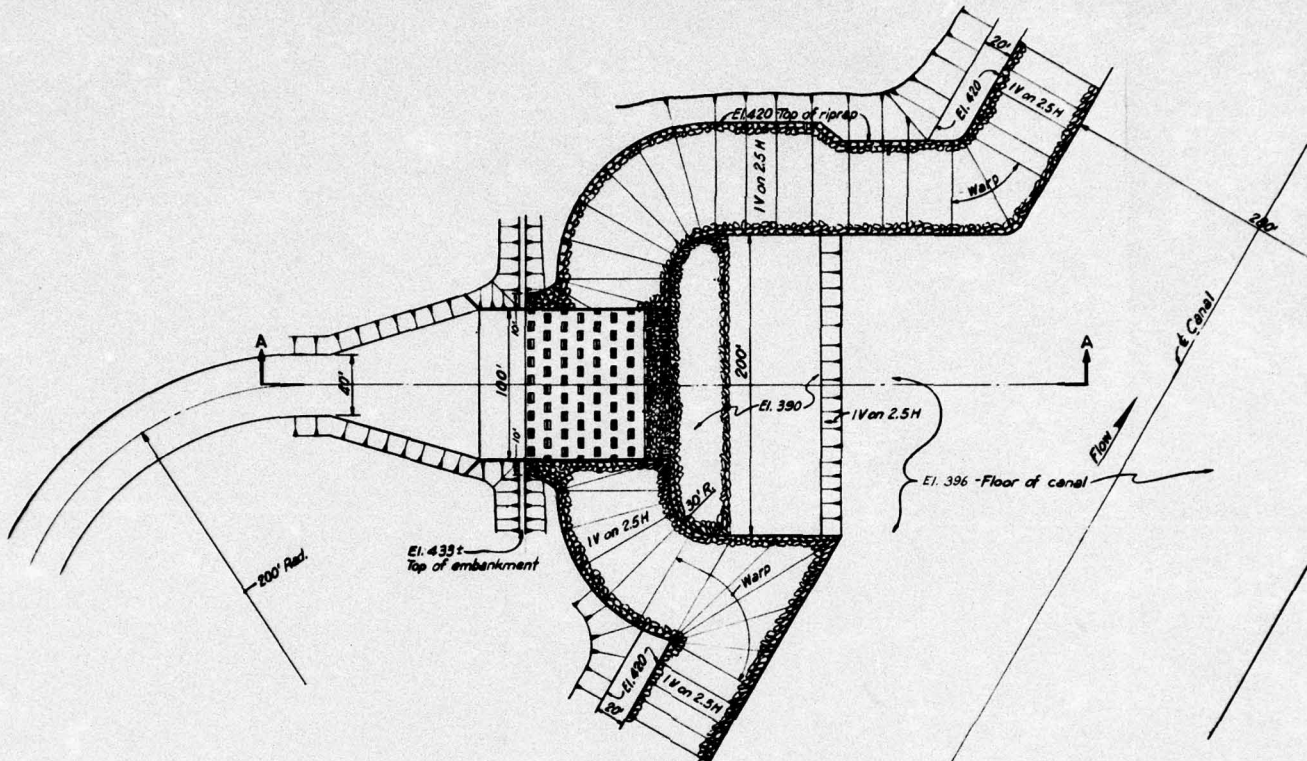

PLAN

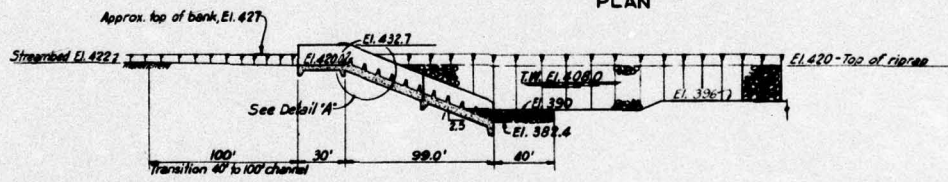

SECTION A-A

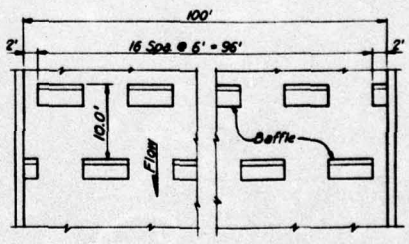

SECTION B-B  
SCALE: 1/4" = 1'-0"

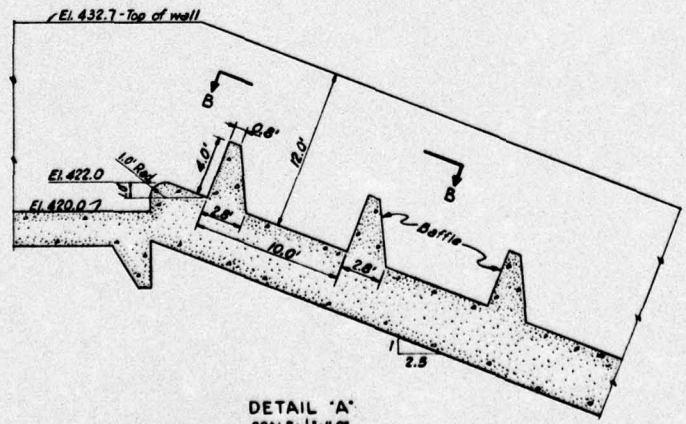

DETAIL 'A'  
SCALE: 1/4" = 1'-0"

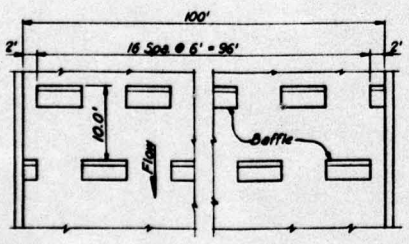
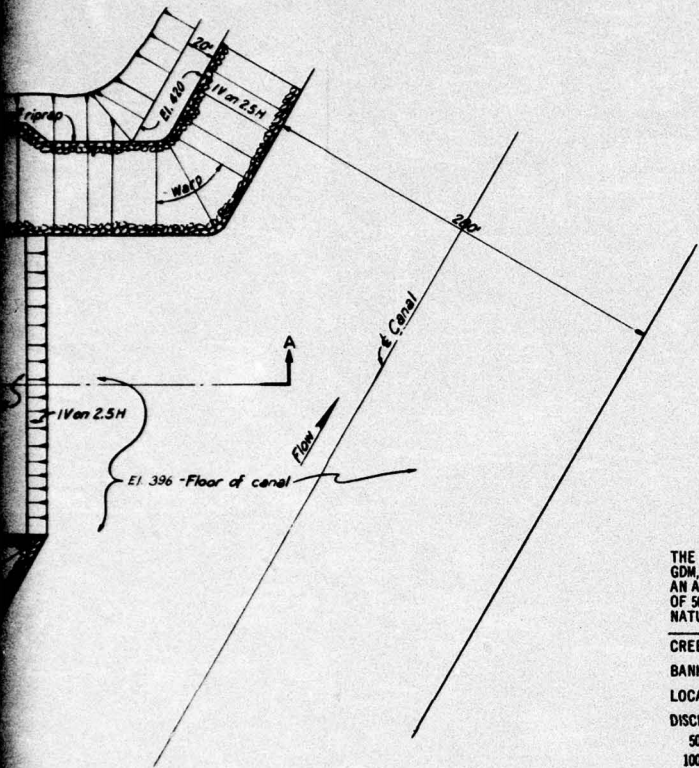

SECTION B-B  
SCALE: 1/4" = 1'-0"

THE MAJOR DRAINAGE STRUCTURES OR BAFFLED CHUTES HAVE BEEN REDESIGNED, SINCE ISSUANCE OF THE GDM, TO ACCOMMODATE 50-YEAR FREQUENCY DISCHARGES AND THE HEIGHT OF SIDE WALLS INCREASED IN AN ATTEMPT TO CONTAIN THE 100-YEAR FLOWS. THE STRUCTURES WERE DESIGNED FOR A UNIT DISCHARGE OF 50 CFS PER FOOT OF WIDTH TO MAINTAIN A REASONABLE ENTRANCE FLARE WHEN TRANSITIONING FROM NATURAL CHANNEL TO STILLING DEVICE. PERTINENT DATA FOR THE FOUR STRUCTURES ARE GIVEN BELOW.

CREEK	LITTLE YELLOW	YELLOW	BEREA	LITTLE YELLOW	ROBINSON
BANK OF CANAL	LEFT	LEFT	LEFT	RIGHT	RIGHT
LOCATION, STATION	13165 + 50	12672 + 41	12775 + 51	12968 + 42	13289 + 00
DISCHARGE, CFS					
50-YEAR FREQUENCY	8400	5400	4500	5900	3800
100-YEAR FREQUENCY	9700	6600	5400	6700	4500
BOTTOM SLOPE	IV: 2H	IV: 3H - IV: 2.5H	IV: 3H - IV: 2.5H	IV: 2H	IV: 2H
WIDTH OF CHUTE, FT	168	106	93	116	76
HEIGHT OF BAFFLE PIERS, FT	3.500	3.500	3.500	3.500	3.50
WIDTH OF BAFFLE PIERS, FT	5.250	5.250	5.250	5.250	5.25
WIDTH OF END PIERS, FT	2.675	3.125	1.875	2.875	2.75
SPACING, ROWS OF PIERS, FT	7.000	7.000	7.000	7.000	7.00
HEIGHT OF SIDE WALLS, FT	11.000	11.500	11.500	11.000	11.00
ASSUMED WIDTH OF STILLING POND, FT	250	160	140	174	148

## MAJOR DRAINAGE STRUCTURES

2

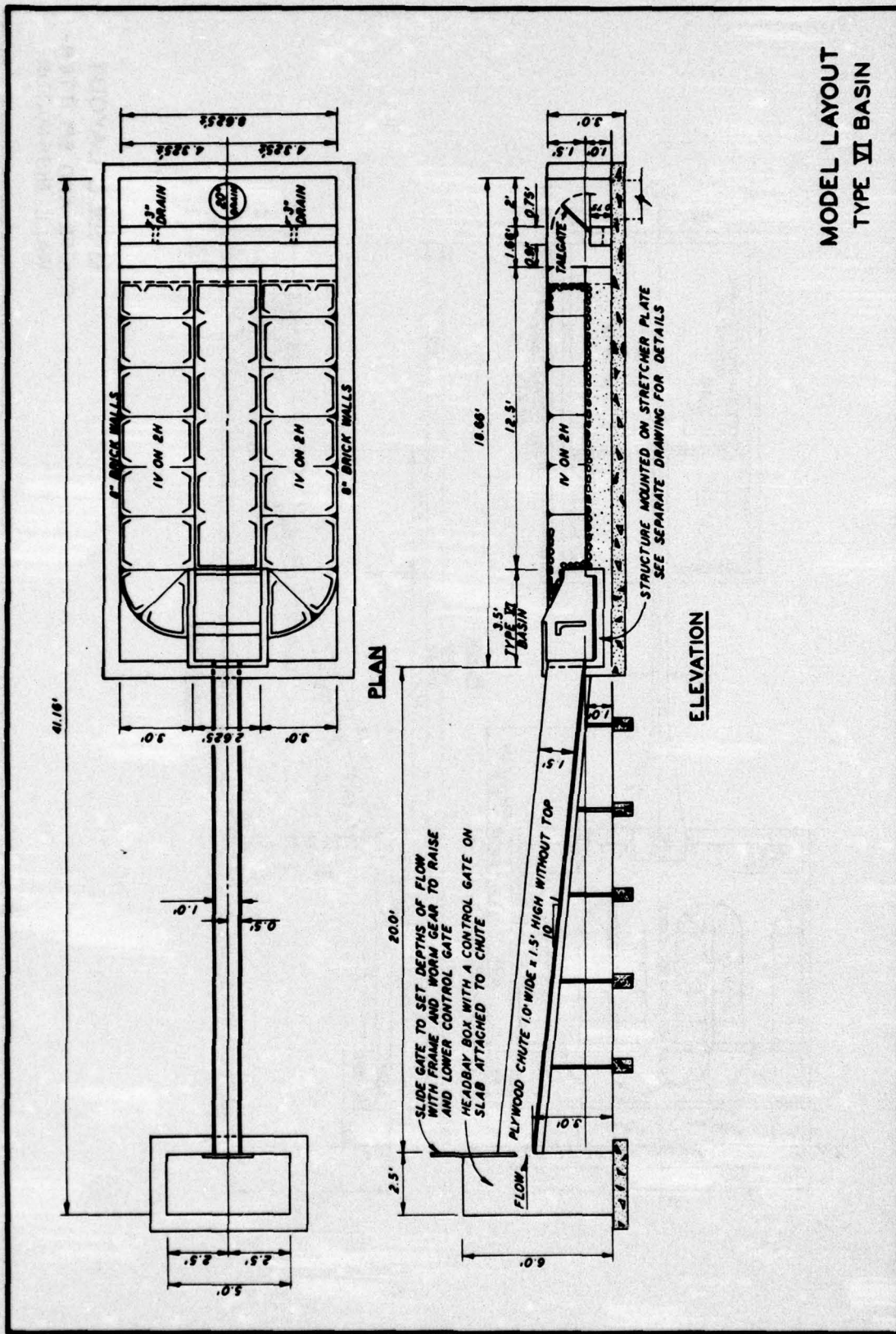

MODEL LAYOUT  
TYPE VI BASIN

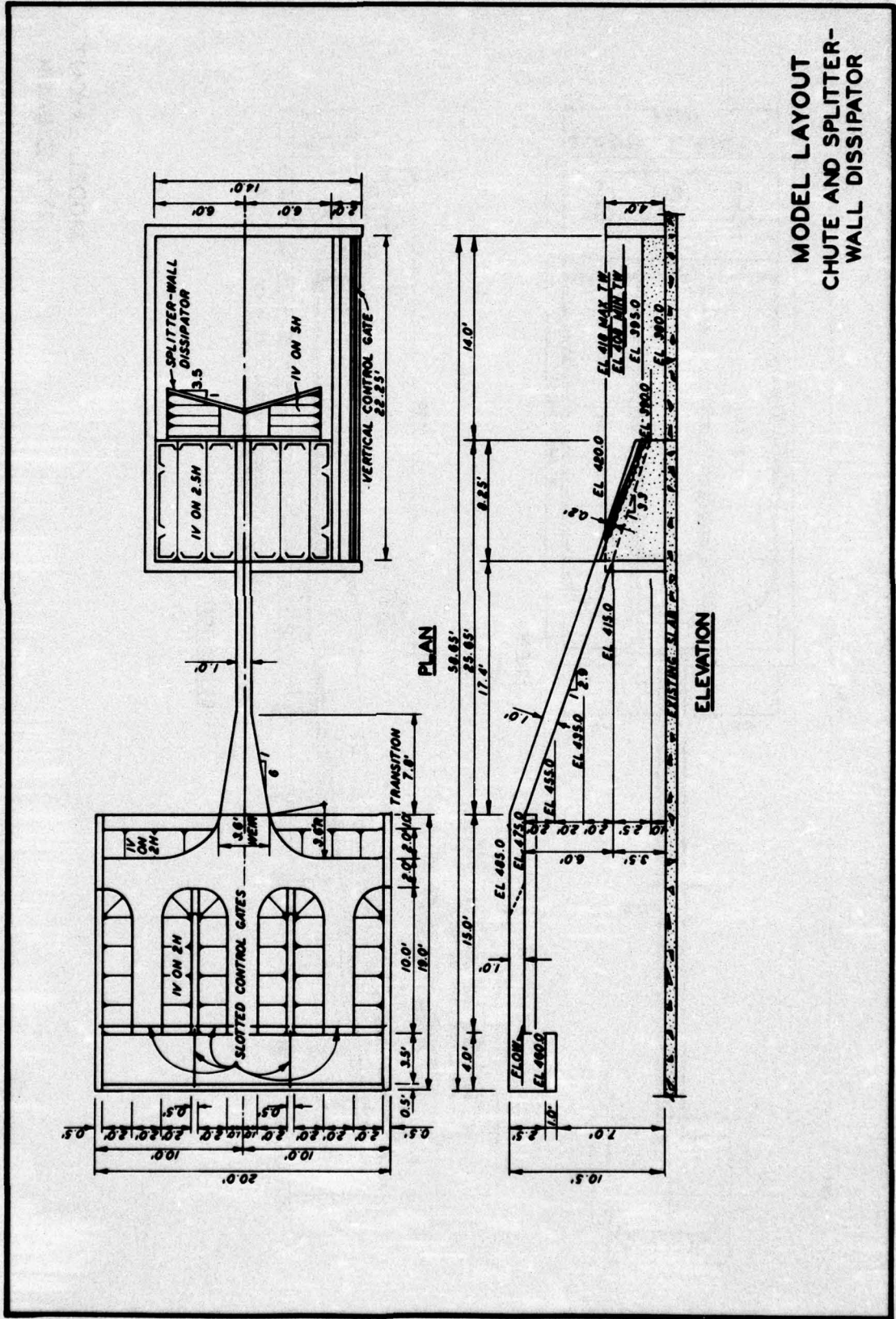

MODEL LAYOUT  
CHUTE AND SPLITTER-  
WALL DISSIPATOR

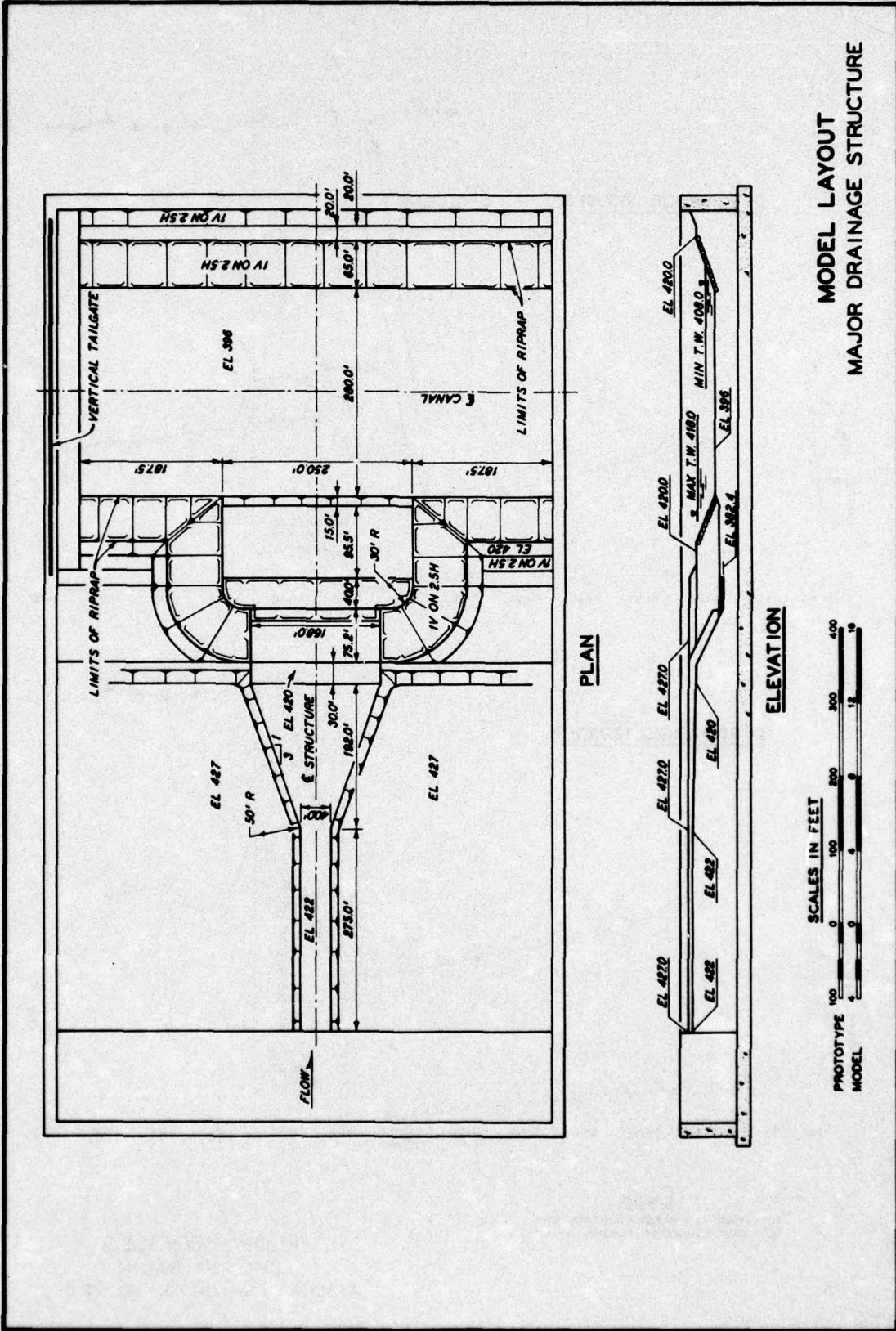

**MODEL LAYOUT  
 MAJOR DRAINAGE STRUCTURE**

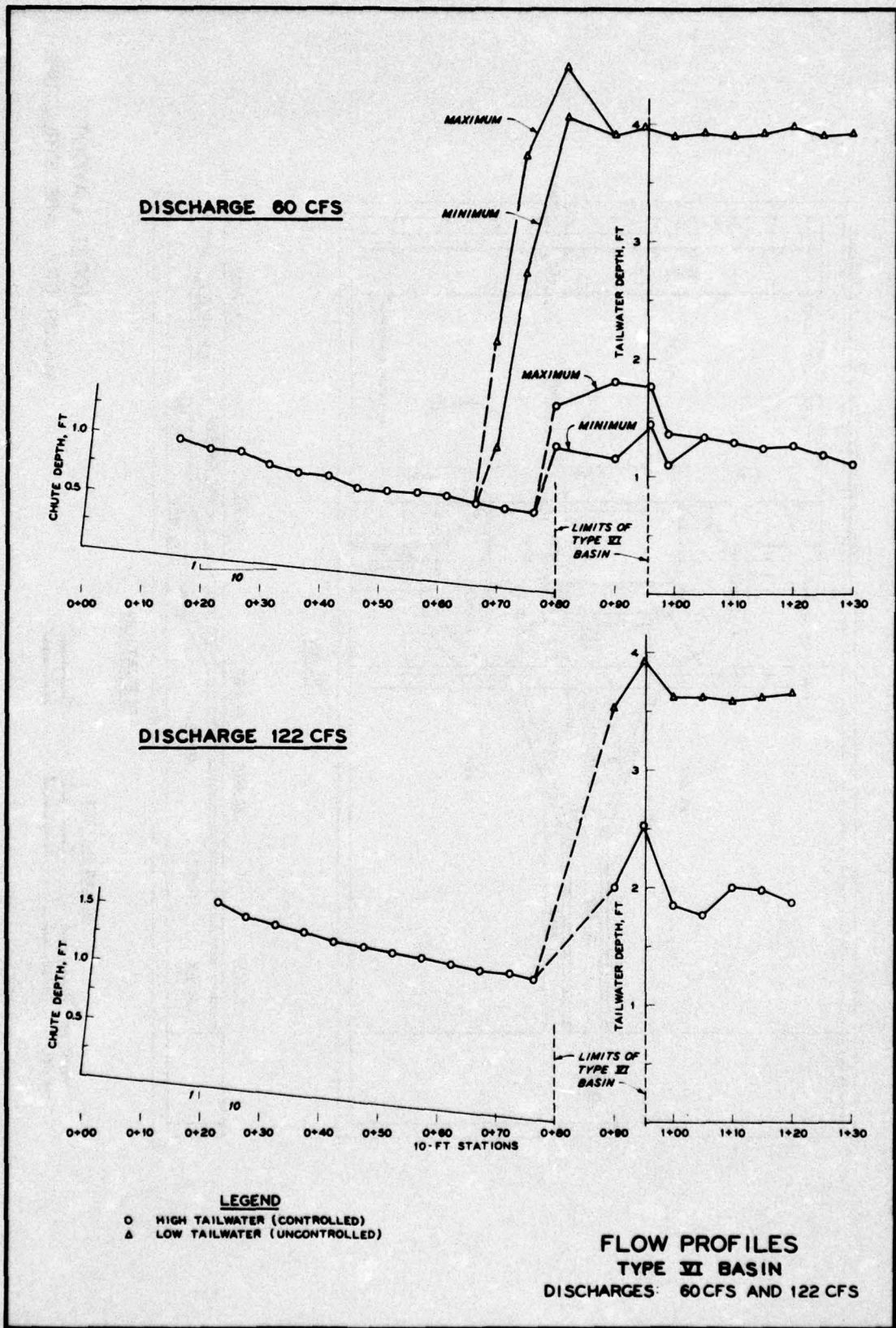

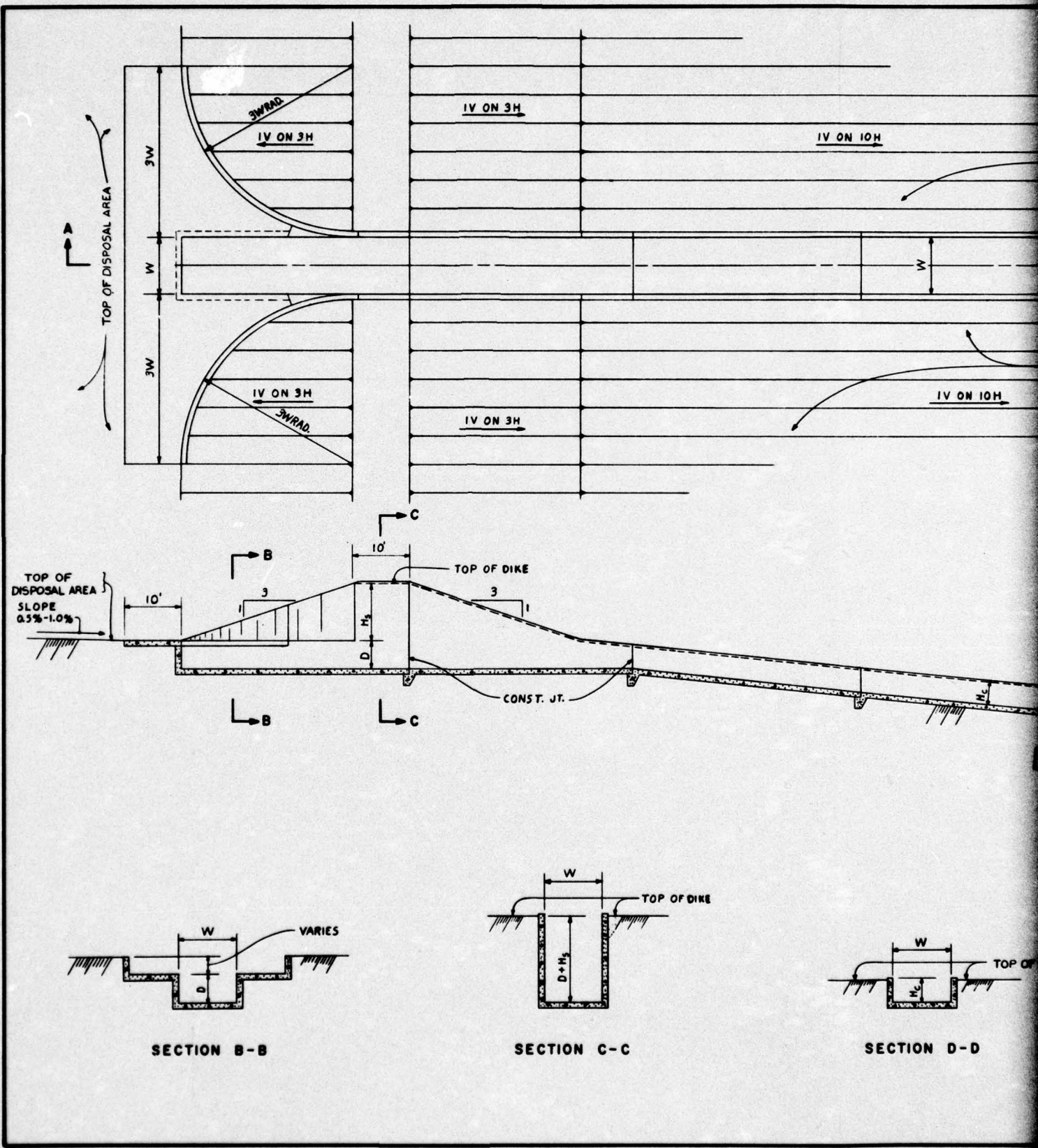

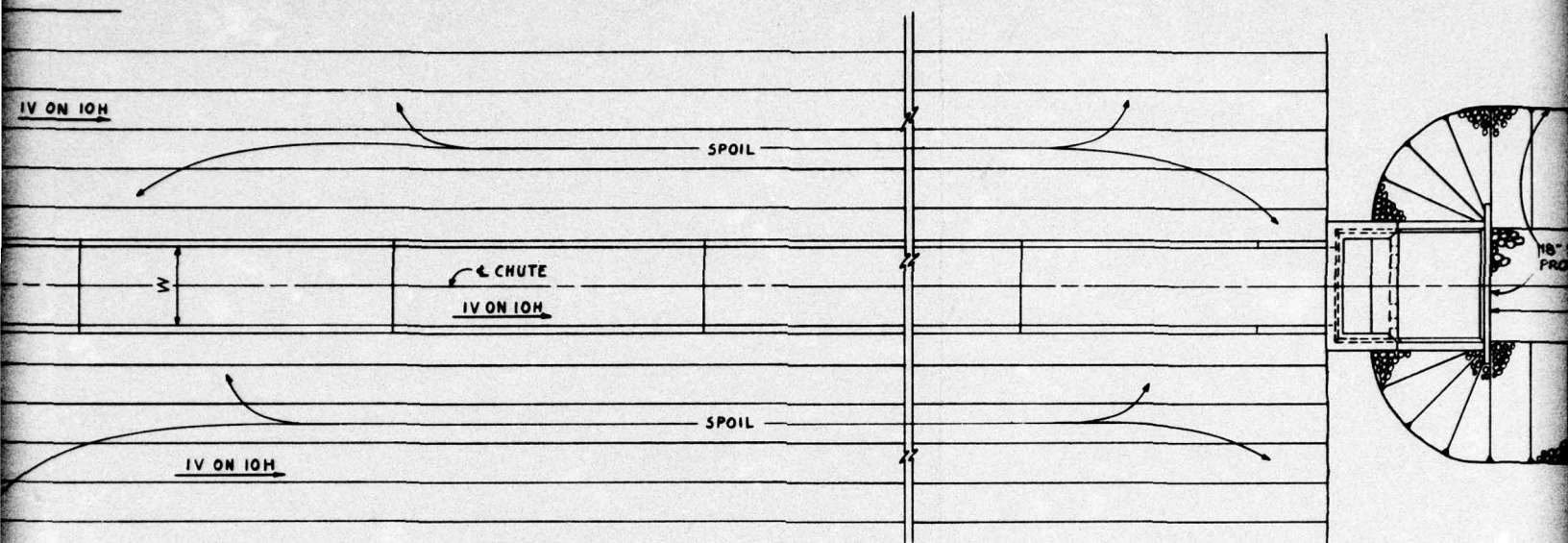

PLAN

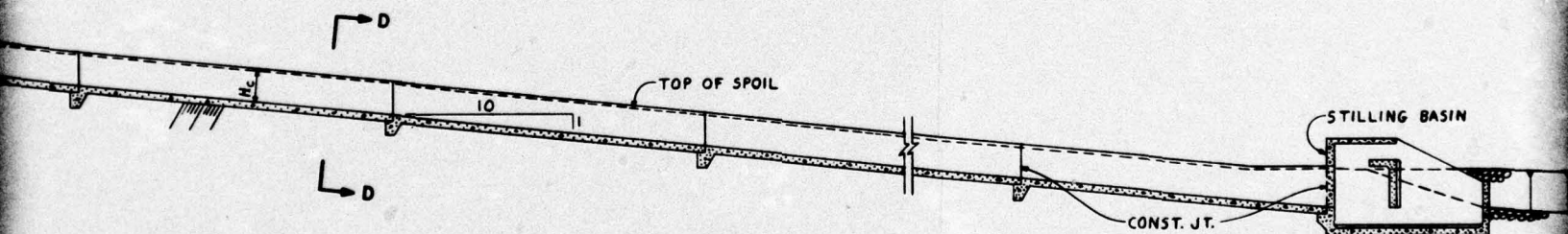

SECTION A-A

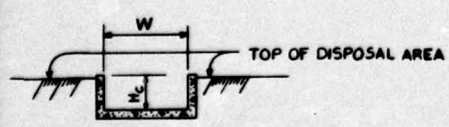

SECTION D-D

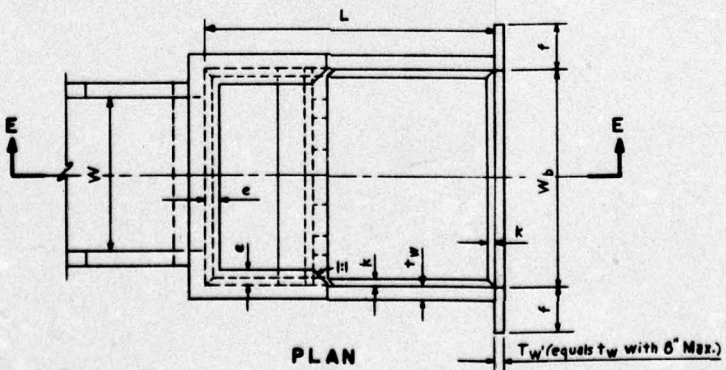

PLAN

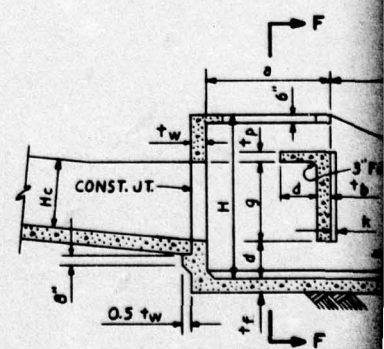

SECTION E-E  
STILLING BASIN

2

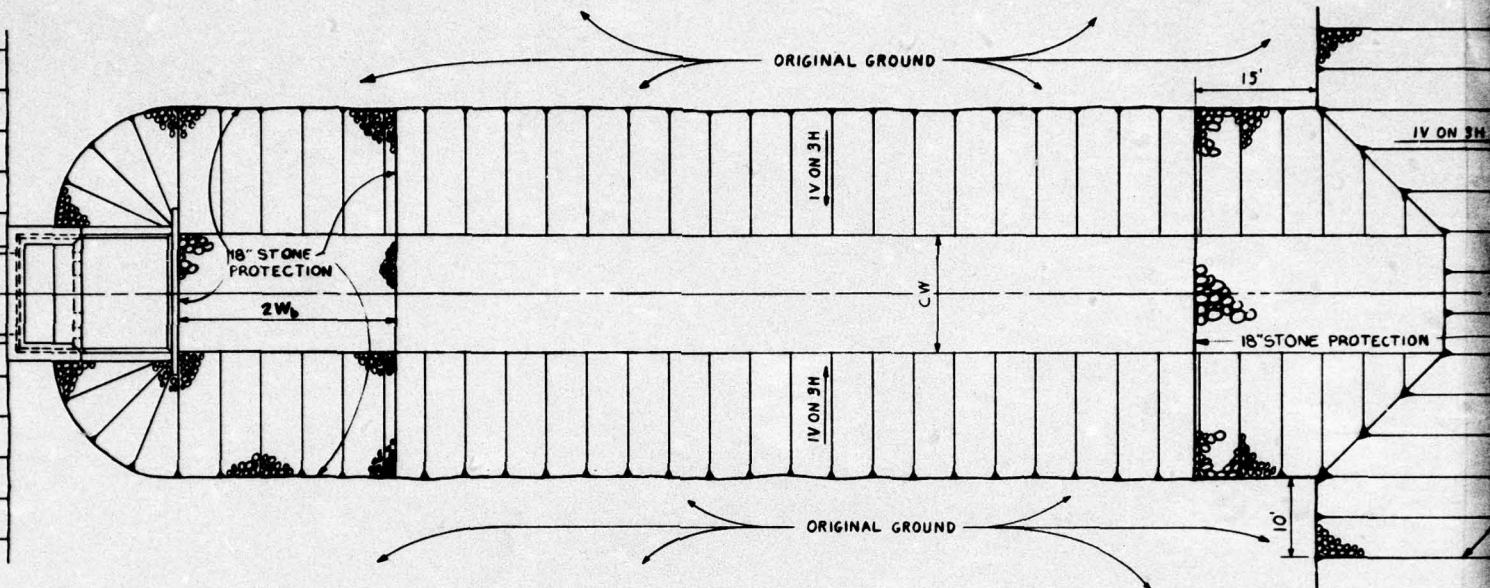

PLAN

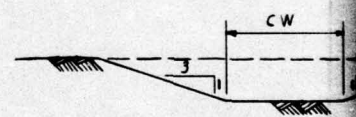

SECTION G-G

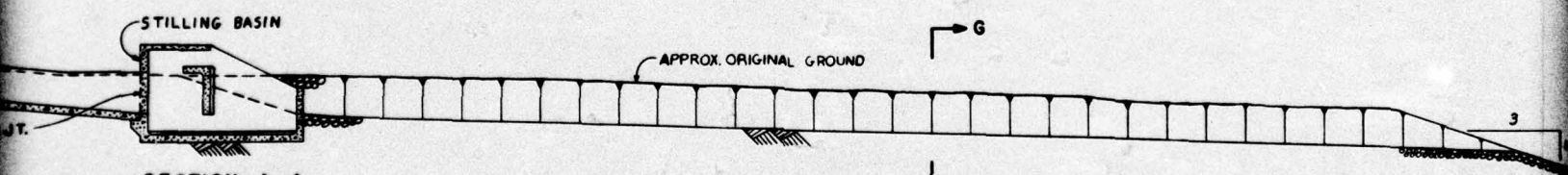

SECTION A-A

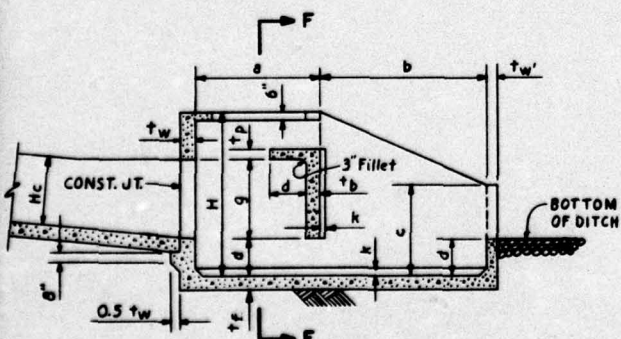

SECTION E-E

STILLING BASIN DETAILS

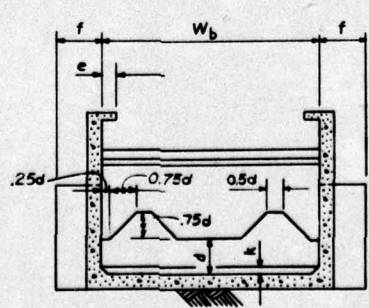

SECTION F-F

MAX. DISCHARGE Q	STILLING BASIN DIMENSIONS									
	FEET AND INCHES									
	W <sub>b</sub>	H	L	a	b	c	d	e	f	g
21	5-6	4-3	7-4	3-3	4-1	2-4	0-11	0-6	1-6	2-1
38	6-9	5-3	9-0	3-11	5-1	2-10	1-2	0-6	2-0	2-4
59	8-0	6-3	10-8	4-7	6-1	3-4	1-4	0-8	2-6	3-0
85	9-3	7-3	12-4	5-3	7-1	3-10	1-7	0-8	3-0	3-6
115	10-6	8-0	14-0	6-0	8-0	4-5	1-9	0-10	3-0	3-11
151	11-9	9-0	15-8	6-9	8-11	4-11	2-0	0-10	3-0	4-5
191	13-0	9-9	17-4	7-4	10-0	5-5	2-2	1-0	3-0	4-11
236	14-3	10-9	19-0	8-0	11-0	5-11	2-5	1-0	3-0	5-4
339	16-6	12-3	22-0	9-3	12-6	6-11	2-9	1-3	3-0	6-2

3

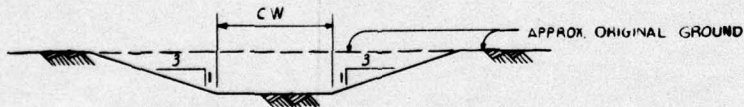
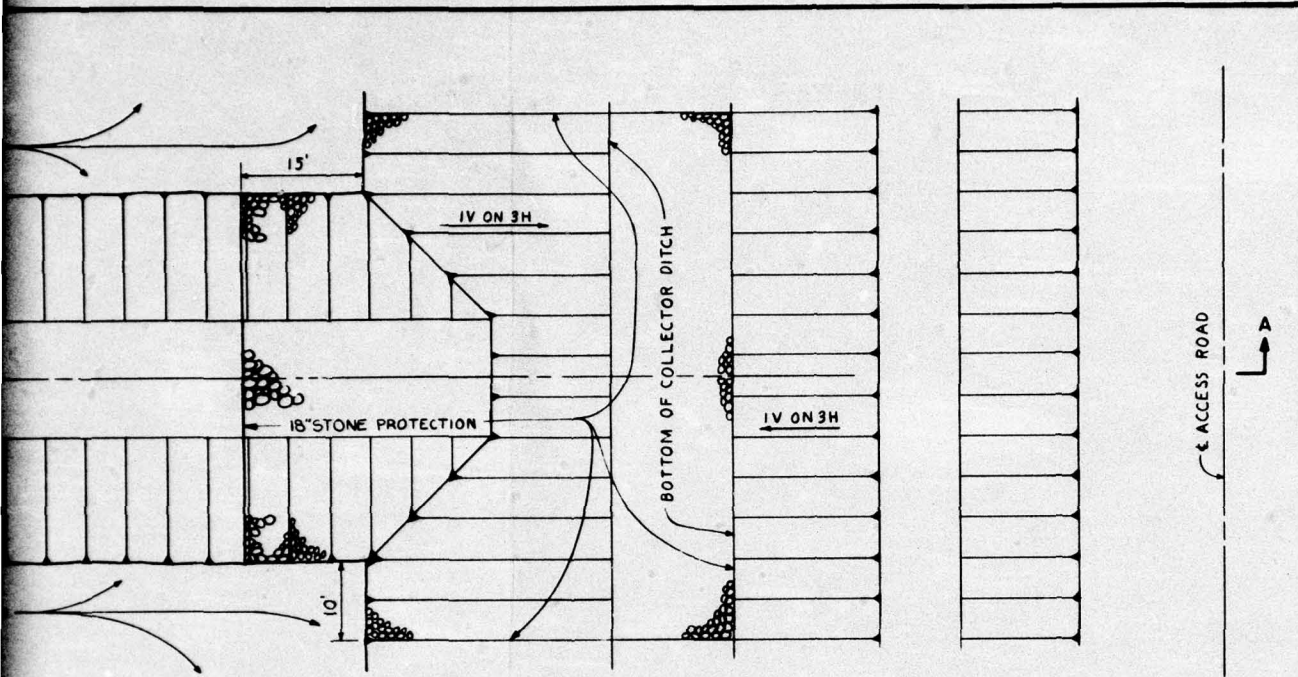

SECTION G-G

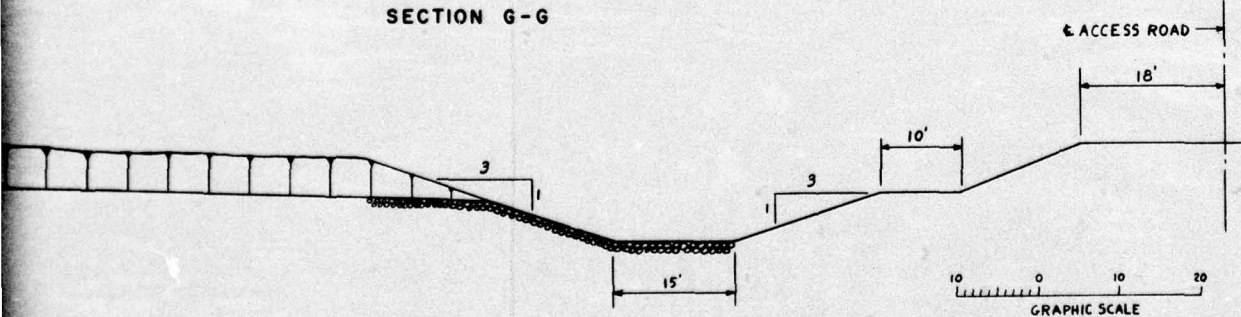

STILLING BASIN DIMENSIONS															
MAX. DISCHARGE Q	FEET AND INCHES										INCHES				
	W <sub>b</sub>	H	L	a	b	c	d	e	f	g	t <sub>w</sub>	t <sub>r</sub>	t <sub>b</sub>	t <sub>p</sub>	K
21	5-6	4-3	7-4	3-3	4-1	2-4	0-11	0-6	1-6	2-1	6	6%	6	6	3
38	6-9	5-3	9-0	3-11	5-1	2-10	1-2	0-6	2-0	2-6	6	6%	6	6	3
59	8-0	6-3	10-8	4-7	6-1	3-4	1-4	0-8	2-6	3-0	6	6%	7	7	3
85	9-3	7-3	12-4	5-3	7-1	3-10	1-7	0-8	3-0	3-6	7	7%	8	8	3
115	10-6	8-0	14-0	6-0	8-0	4-5	1-9	0-10	3-0	3-11	8	8%	9	8	4
151	11-9	9-0	15-8	6-9	8-11	4-11	2-0	0-10	3-0	4-5	9	9%	10	8	4
191	13-0	9-9	17-4	7-4	10-0	5-5	2-2	1-0	3-0	4-11	10	10%	10	8	4
236	14-3	10-9	19-0	8-0	11-0	5-11	2-5	1-0	3-0	5-4	11	11%	11	8	6
339	16-6	12-3	22-0	9-3	12-6	6-11	2-9	1-3	3-0	6-2	12	12%	12	8	6

DISPOSAL AREA  
TYPICAL STRUCTURE

4

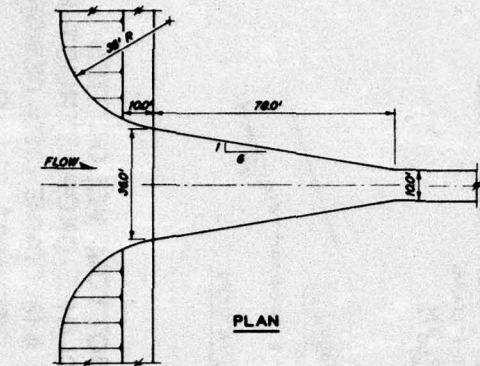

PLAN

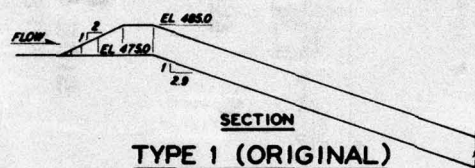

SECTION  
TYPE 1 (ORIGINAL)

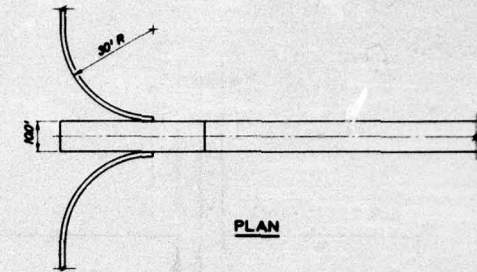

PLAN

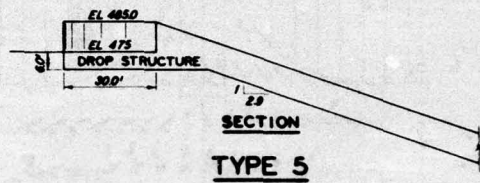

SECTION  
TYPE 5

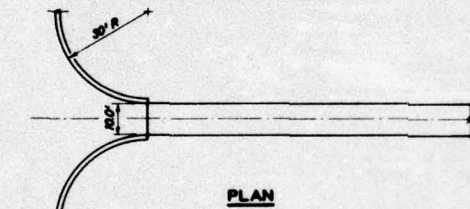

PLAN

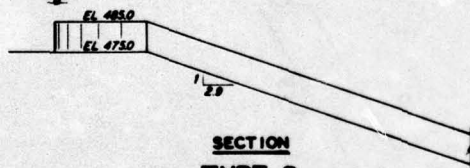

SECTION  
TYPE 2

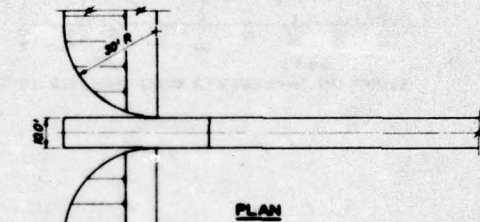

PLAN

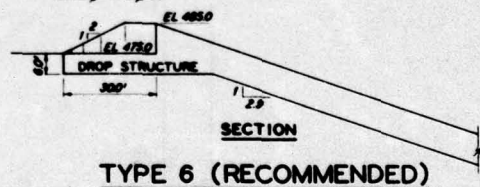

SECTION  
TYPE 6 (RECOMMENDED)

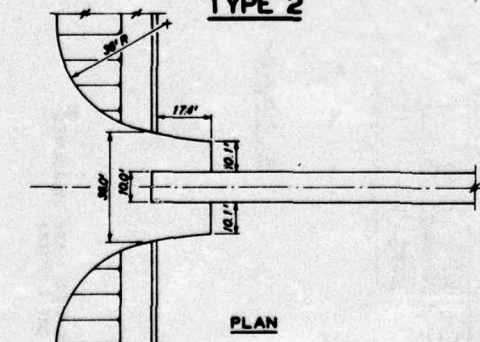

PLAN

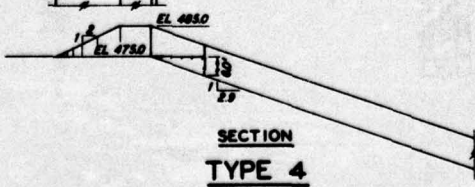

SECTION  
TYPE 4

TRANSITION OR ENTRANCE  
AND DROP STRUCTURE  
LEADING TO DRAINAGE  
STRUCTURE CHUTES  
FOR CUT SECTION  
TYPES 1, 2, 4, 5, AND  
6 (RECOMMENDED)

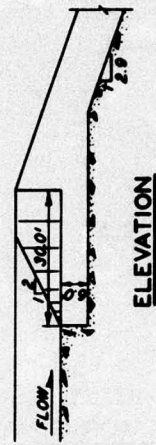
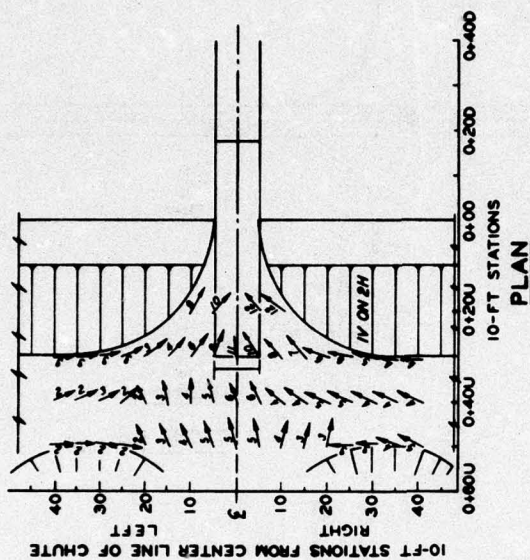

**BOTTOM VELOCITIES  
SIDE SLOPE DROP STRUCTURE  
TYPE 6 (RECOMMENDED) DESIGN  
DISCHARGE: 900 CFS**

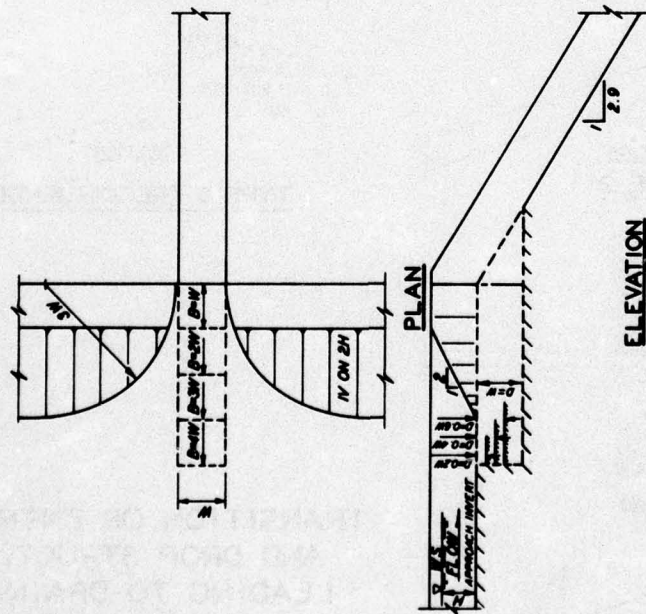

NOTE: VELOCITIES WERE MEASURED  
1 FT OFF BOTTOM

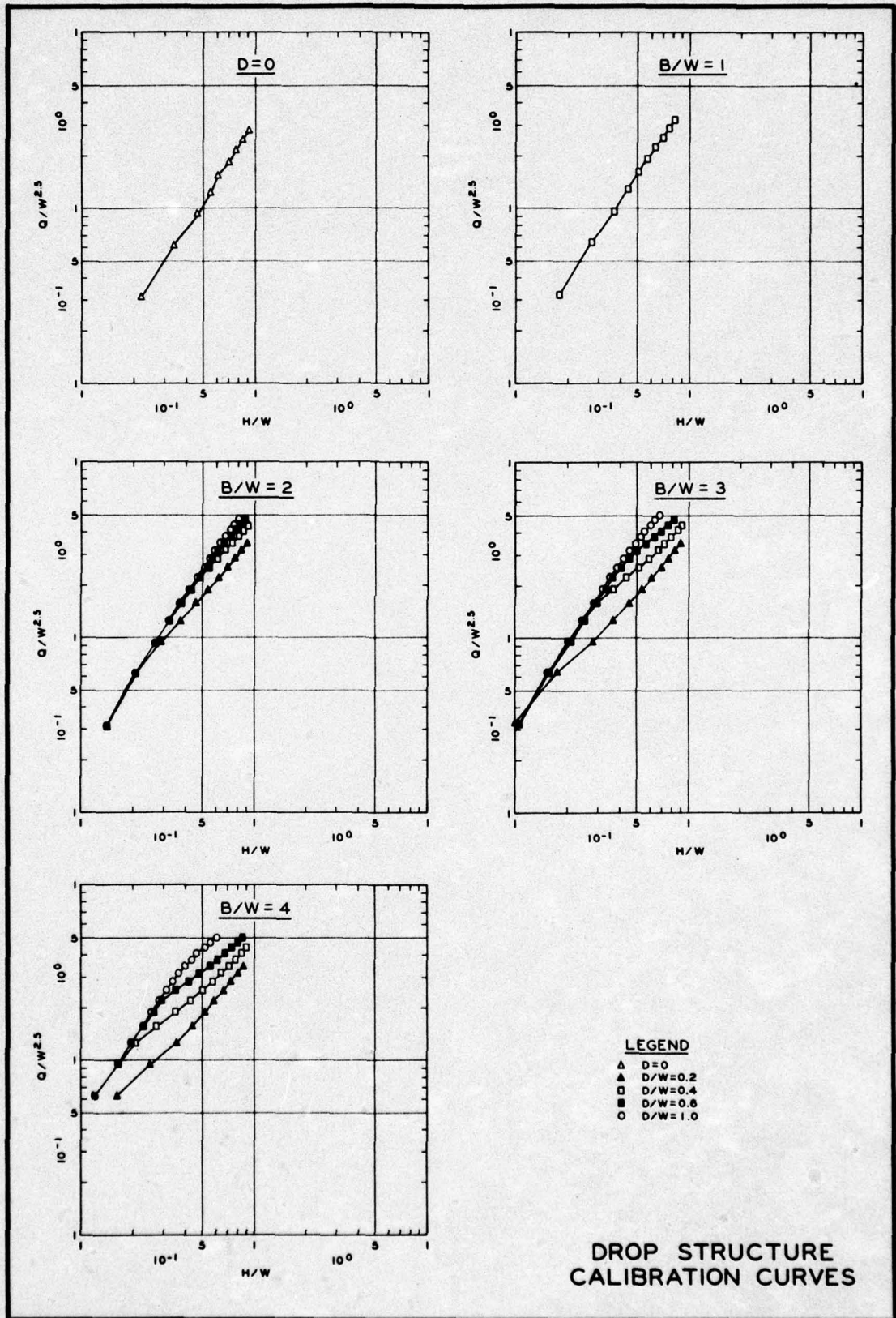

DROP STRUCTURE  
CALIBRATION CURVES

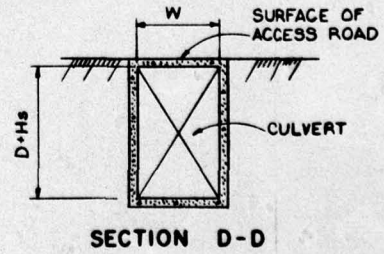
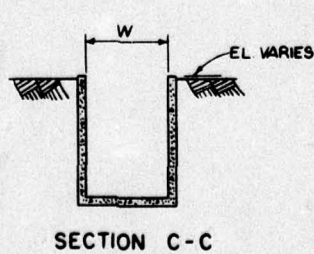
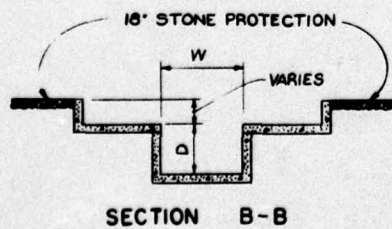
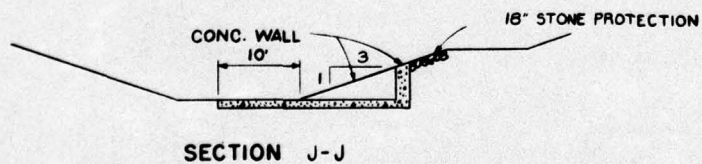
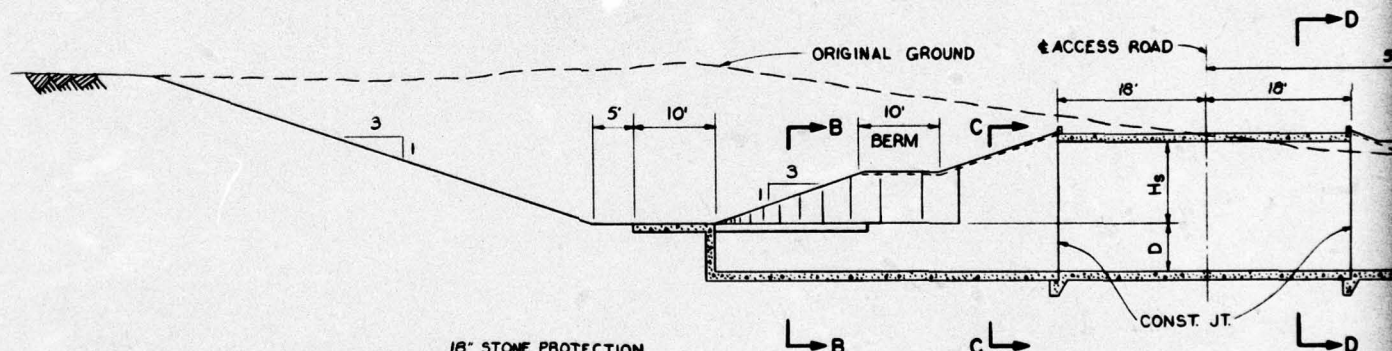
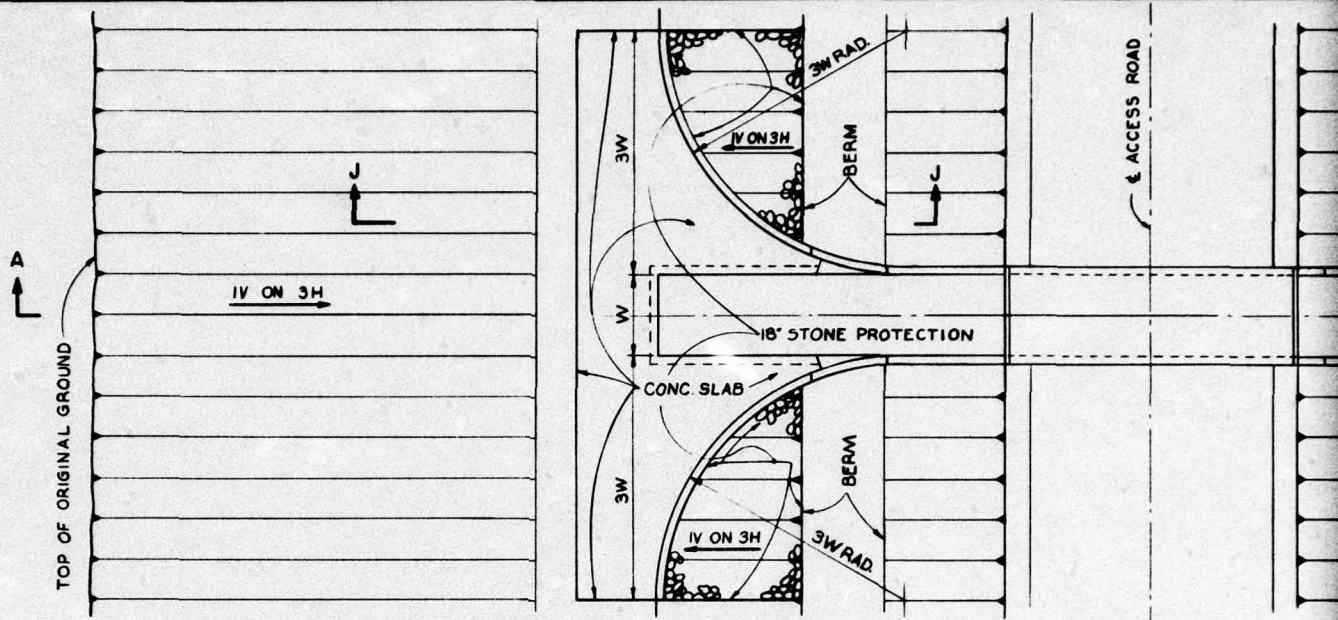

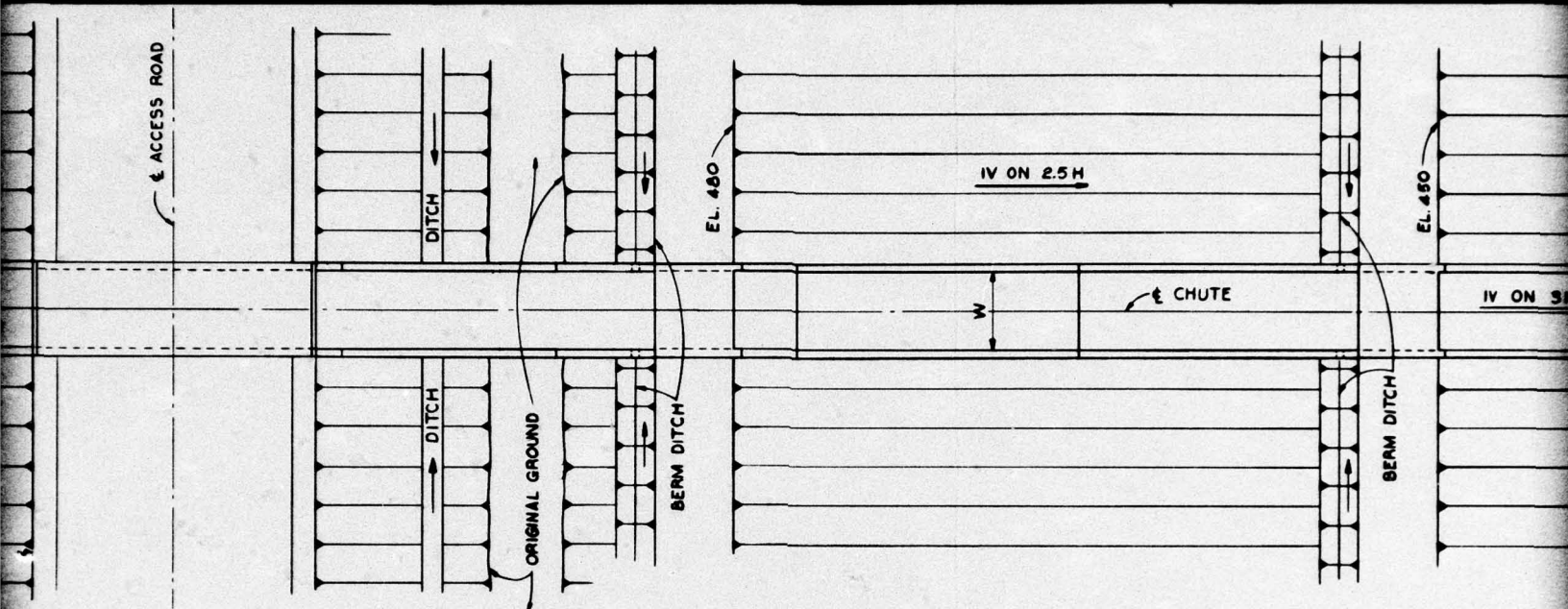

PLAN

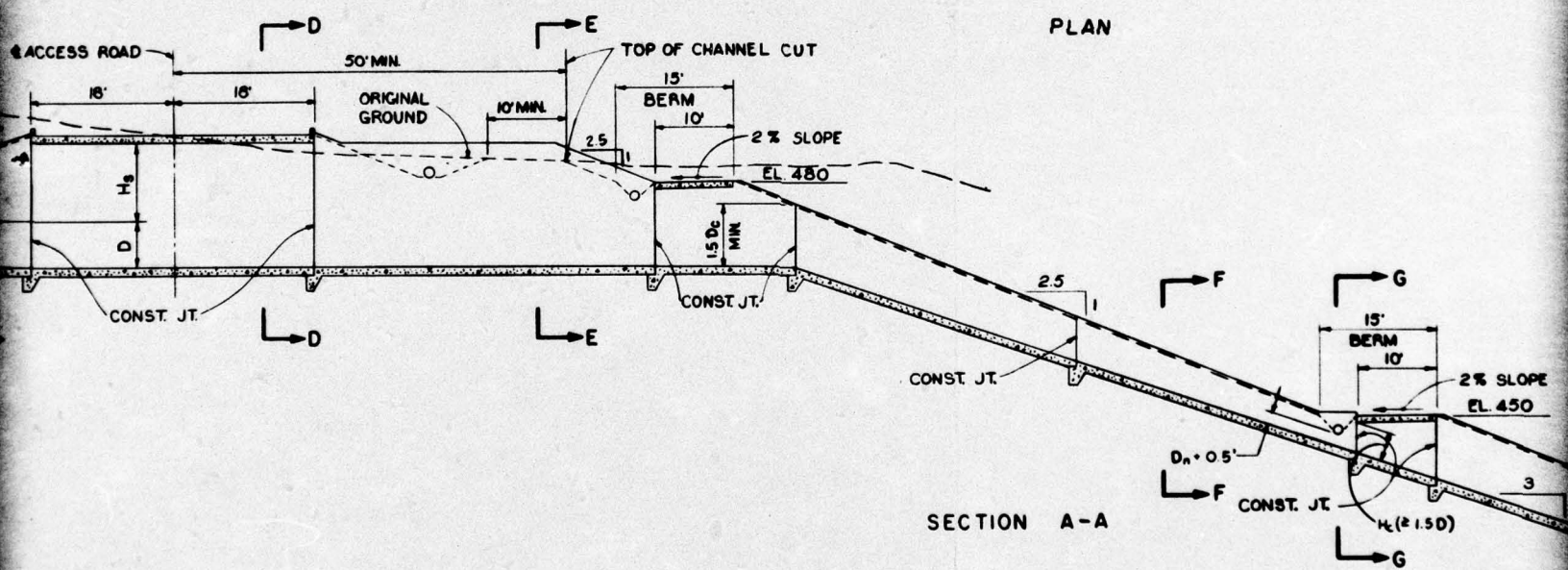

SECTION A-A

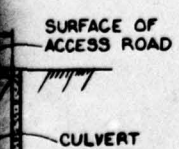

D-D

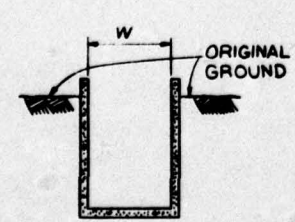

SECTION E-E

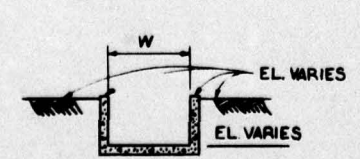

SECTION F-F TYPICAL

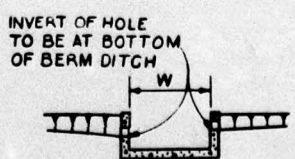

SECTION G-G TYPICAL AT BERM DITCH

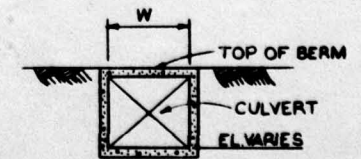

SECTION H-H TYPICAL AT BERM

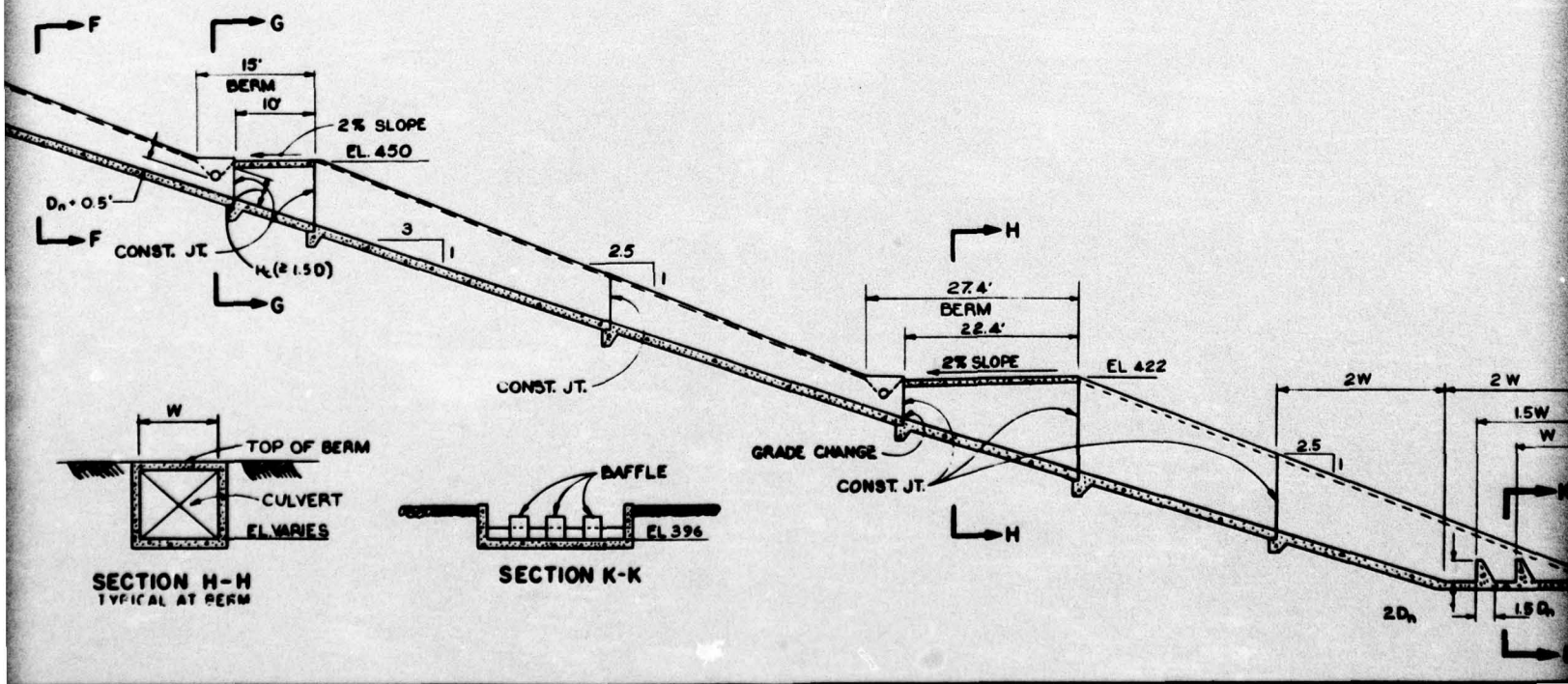
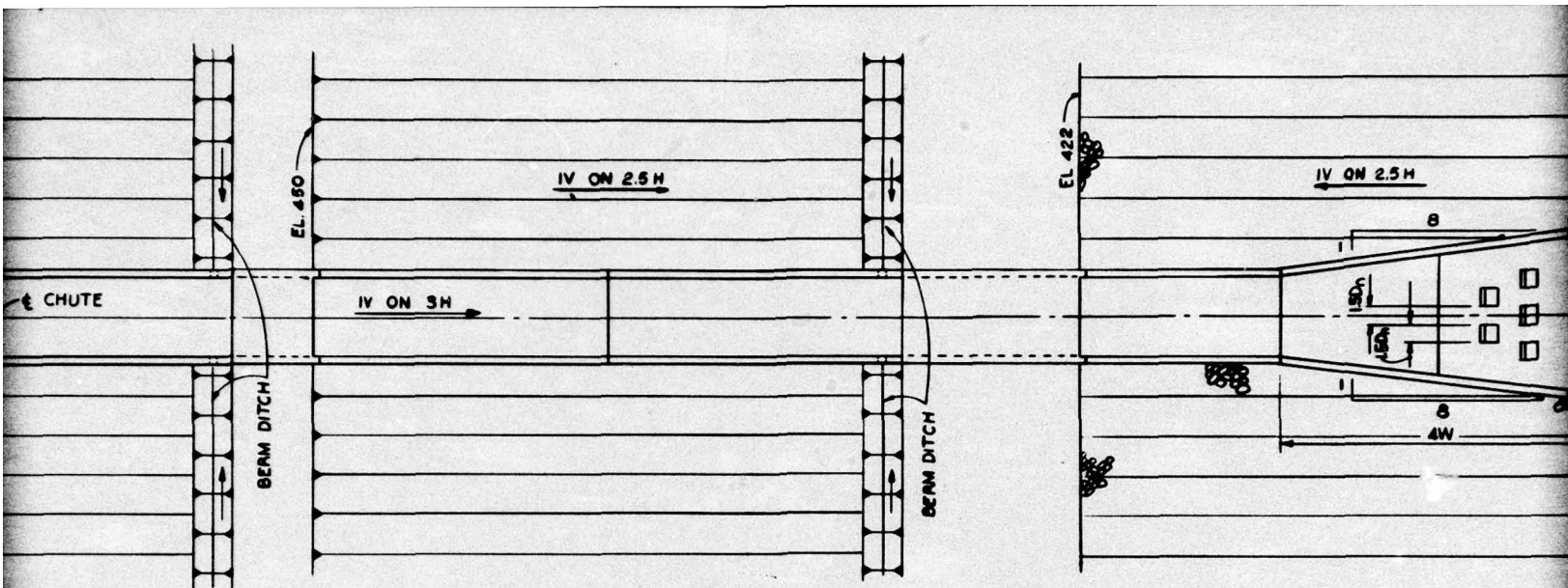



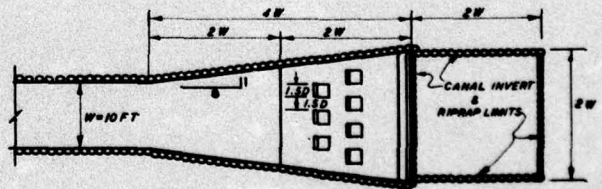
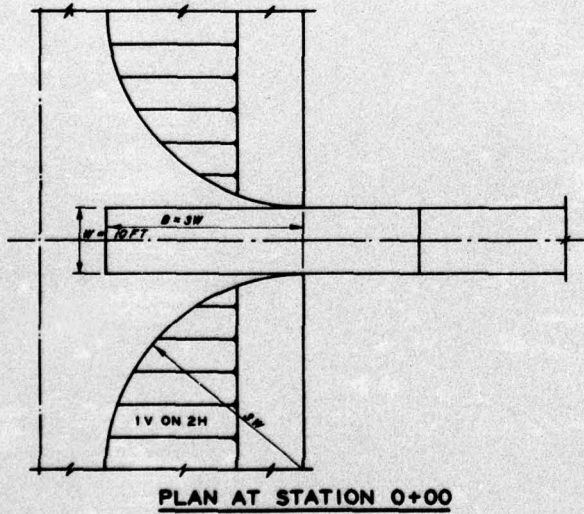
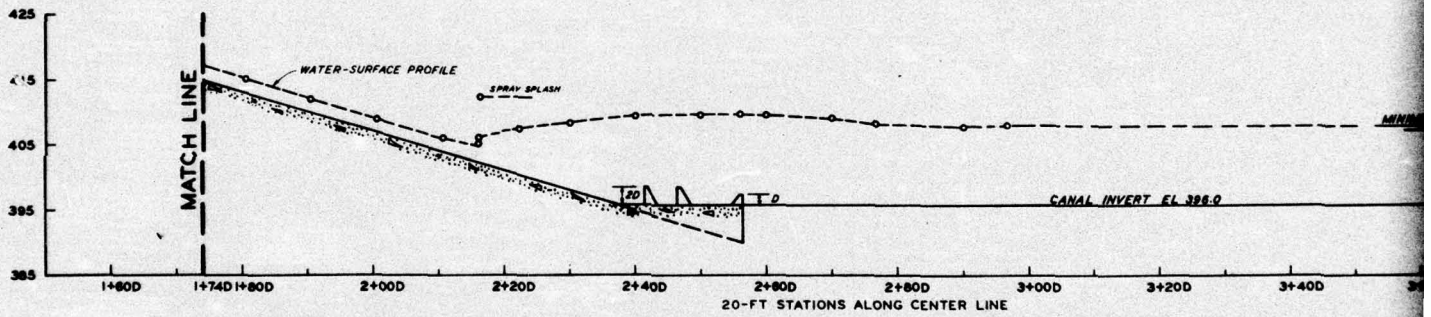
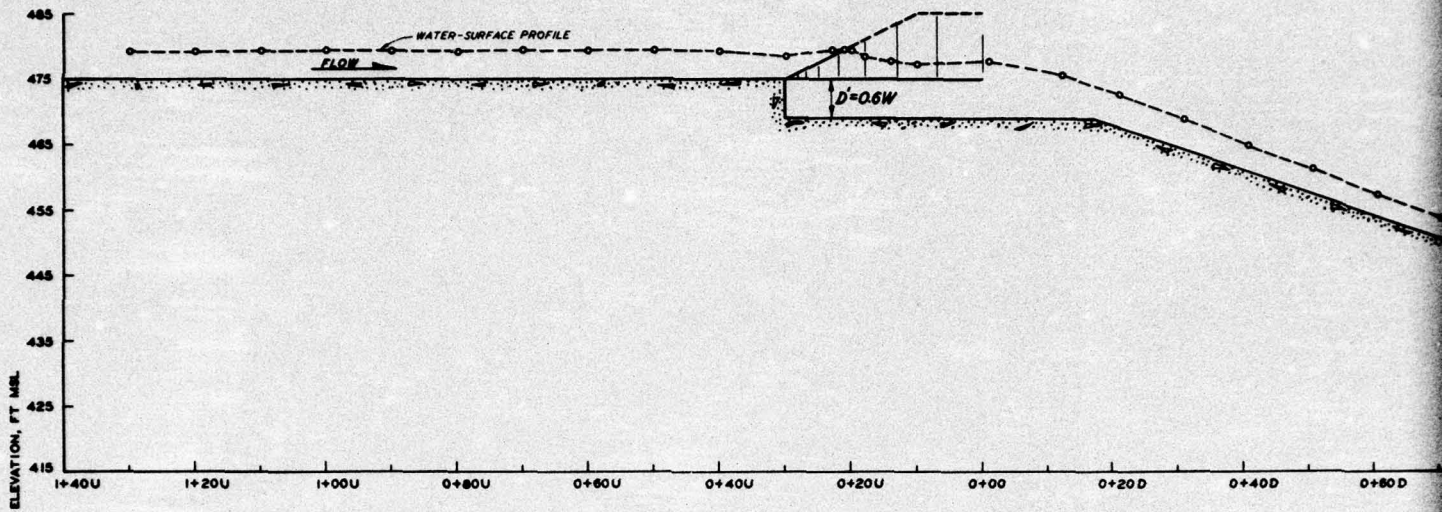

**PLAN AT STATION 2+40D**



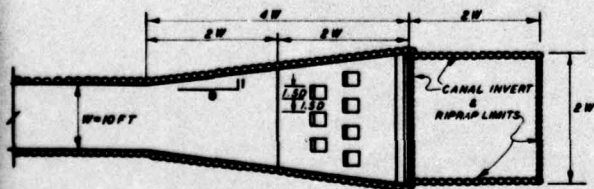
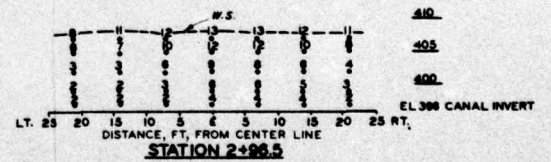
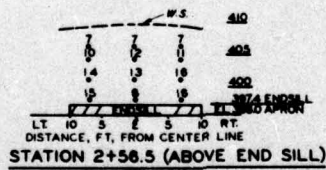
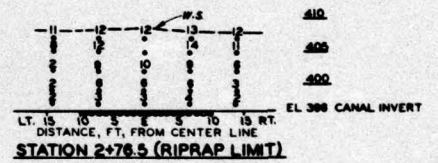
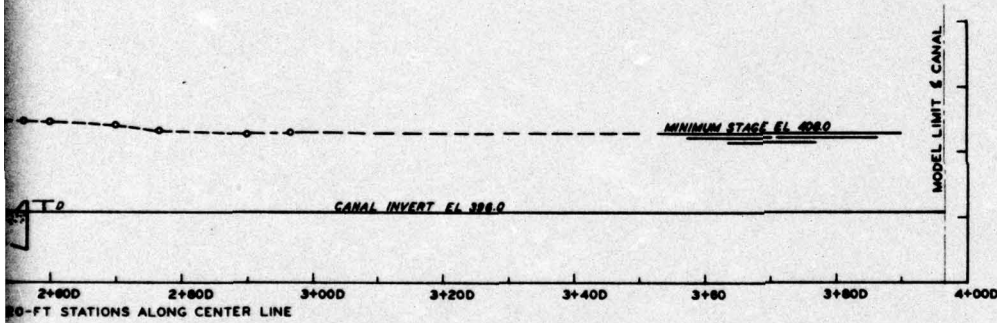
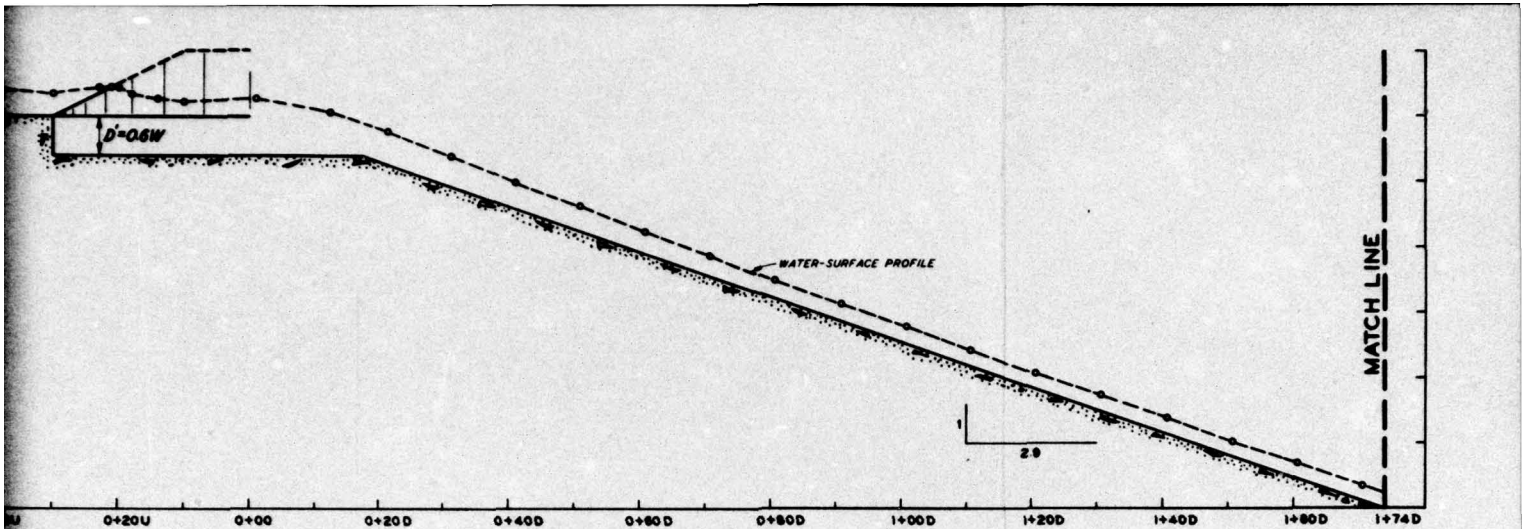

## WATER-SURFACE PROFILE THROUGH STRUCTURE AND VELOCITIES DOWNSTREAM OF DISSIPATOR

TYPE 6 DROP STRUCTURE, 10-FT CHUTE, &  
TYPE 18 DISSIPATOR  
DISCHARGE 900 CFS    CANAL STAGE 408.0 (MIN.)

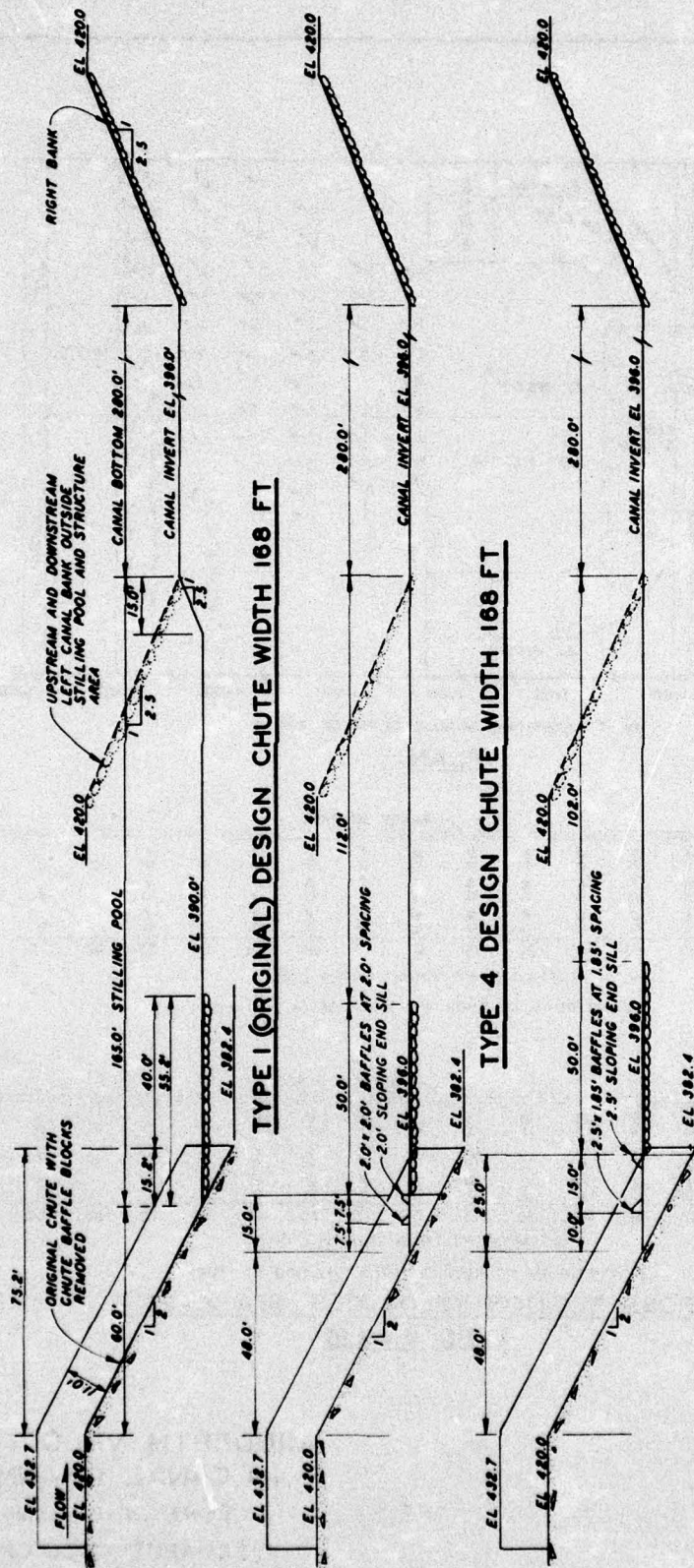

**TYPE I (ORIGINAL) DESIGN CHUTE WIDTH 168 FT**

**TYPE 4 DESIGN CHUTE WIDTH 168 FT**

**TYPE 10 DESIGN CHUTE WIDTH REDUCED TO 100 FT**

TYPE I (ORIGINAL) DESIGN CHUTE  
WITH CHUTE BAFFLES REMOVED  
TYPES 4 AND 10 STILLING BASINS

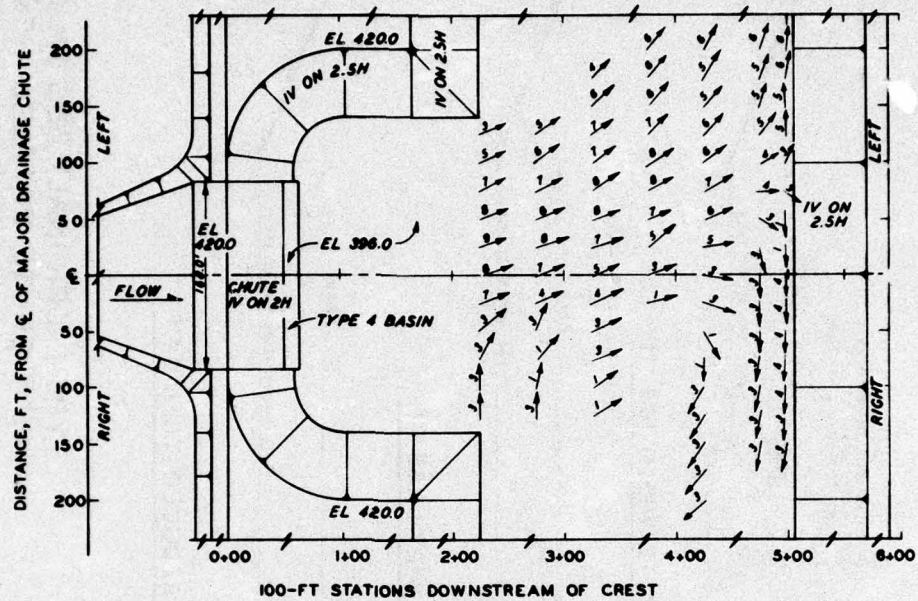

**PLAN**

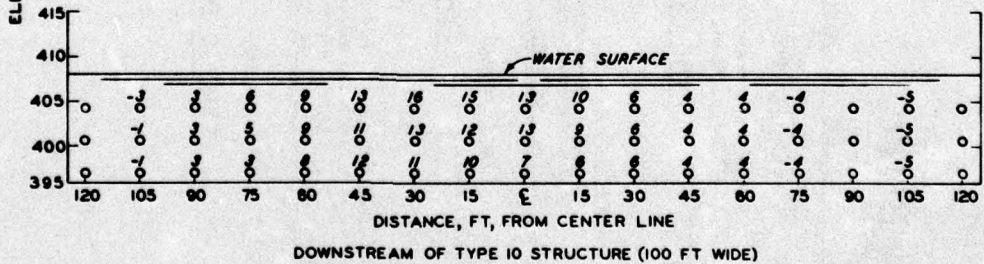
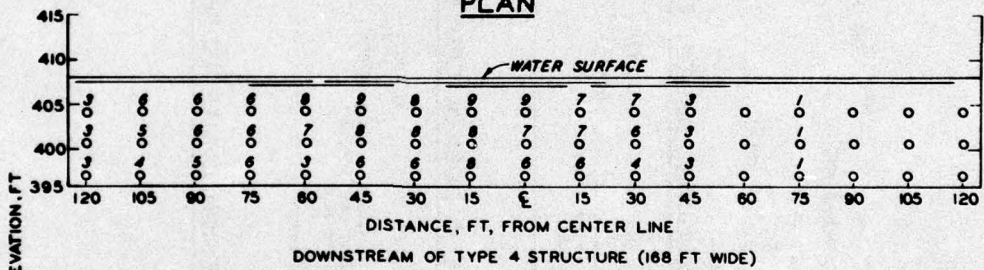

**CROSS-SECTION VELOCITIES STA 2+25.7**

**TYPE 4 VS 10**

**MIDDEPTH VELOCITIES  
IN CANAL CHANNEL  
TYPE 4 BASIN  
DISCHARGE 9700 CFS  
CANAL STAGE 408**

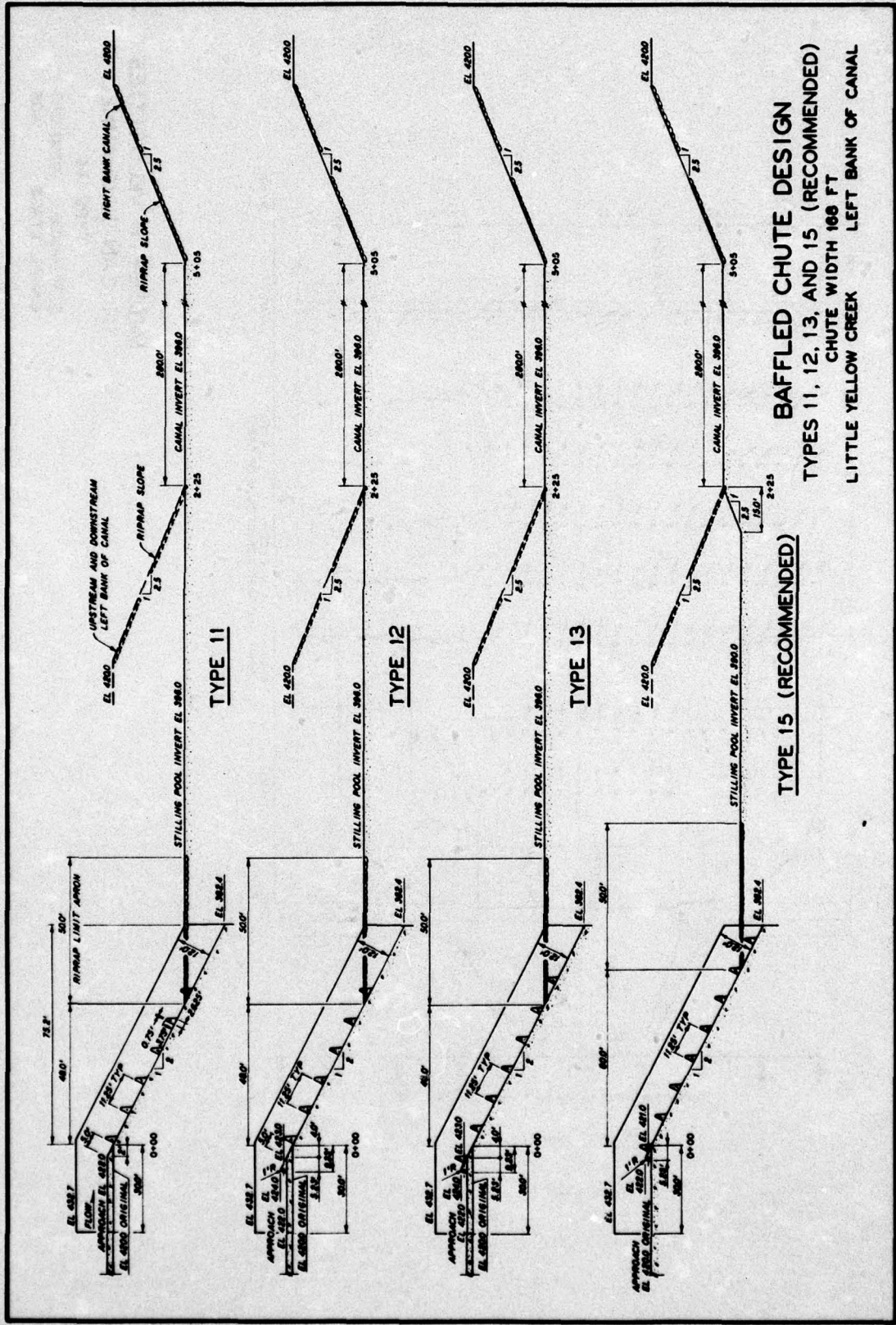

**BAFFLED CHUTE DESIGN**  
**TYPES 11, 12, 13, AND 15 (RECOMMENDED)**  
 CHUTE WIDTH 100 FT  
 LITTLE YELLOW CREEK LEFT BANK OF CANAL

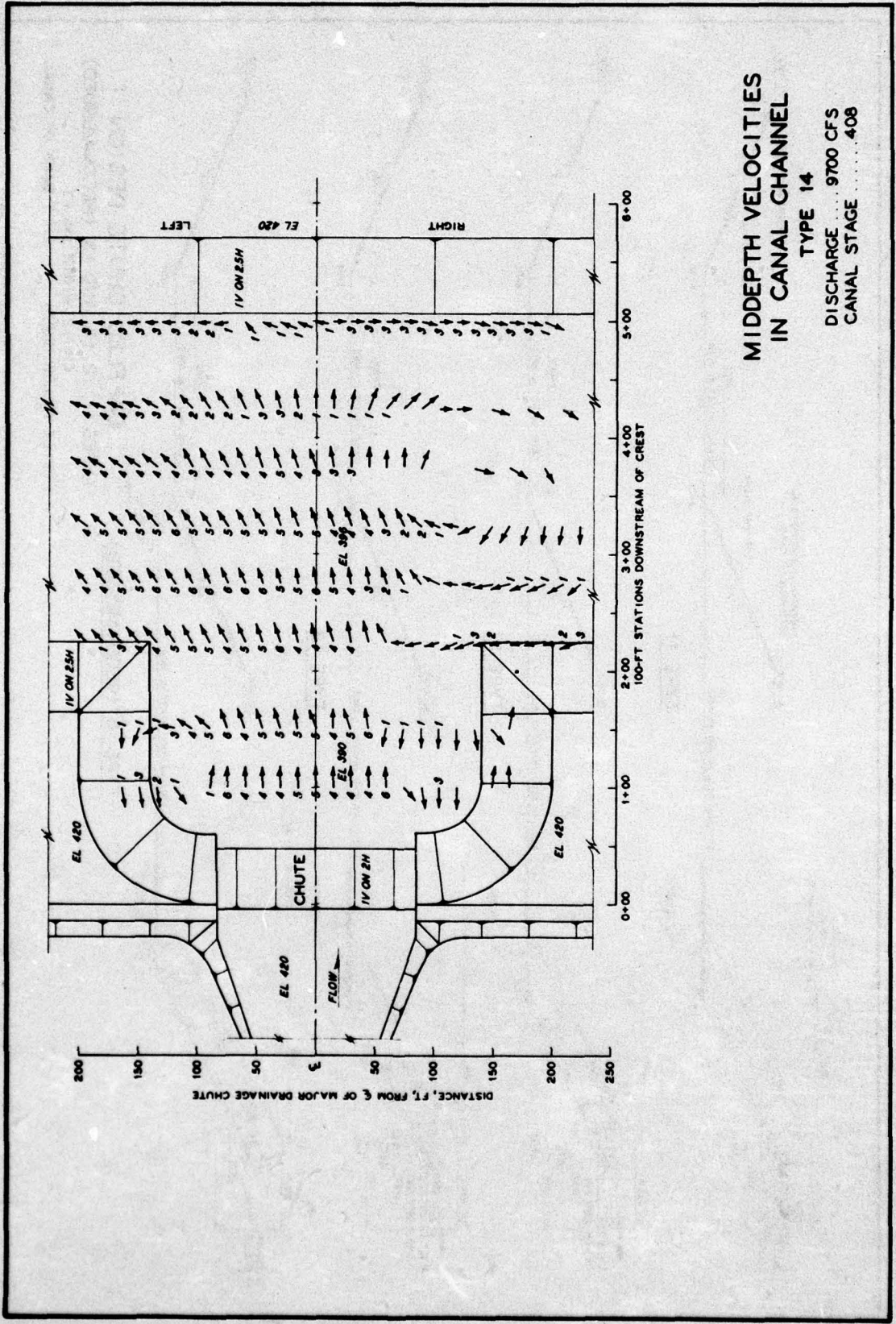

**MIDDEPTH VELOCITIES  
 IN CANAL CHANNEL**  
 TYPE 14  
 DISCHARGE ..... 9700 CFS  
 CANAL STAGE ..... 408

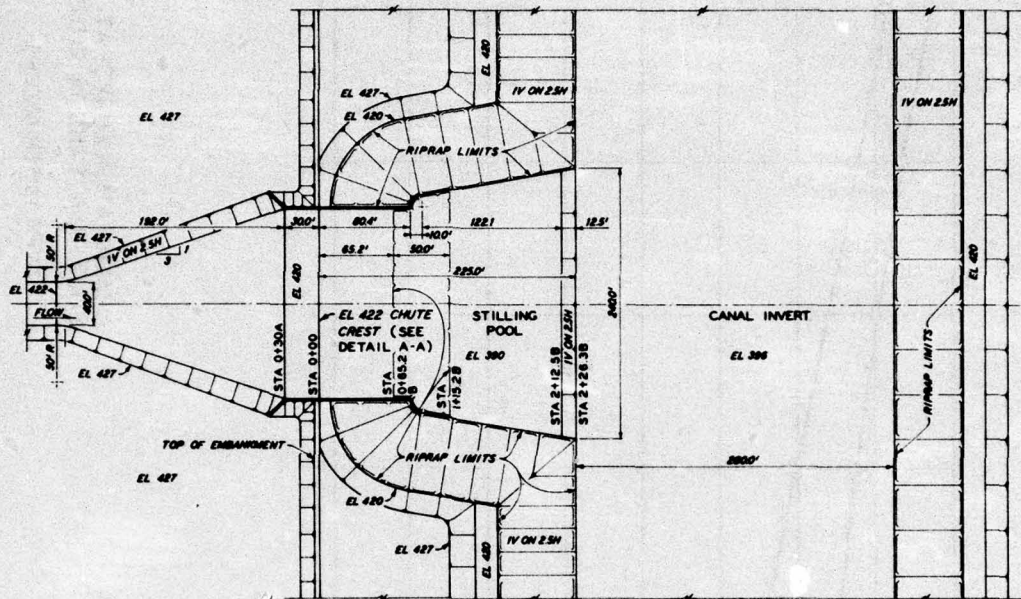

**PLAN SHOWING STRUCTURE,  
ABUTMENTS, AND RIPRAP LIMITS**

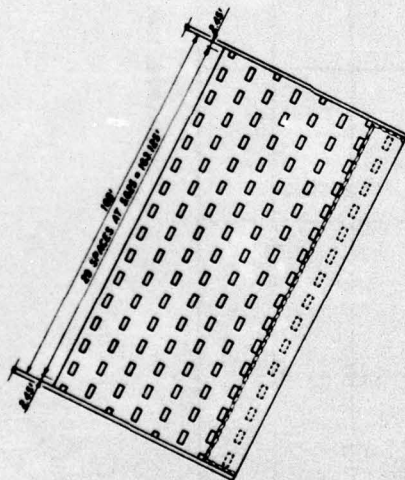

**CREST DETAIL**



**BAFFLE BLOCK  
DETAIL**

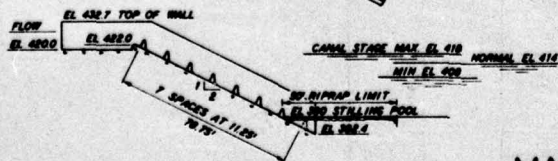

**DETAIL A-A**

**MAJOR DRAINAGE STRUCTURE  
WITH BAFFLED CHUTE  
TYPE 15 (RECOMMENDED) DESIGN  
LITTLE YELLOW CREEK  
LEFT BANK OF CANAL**

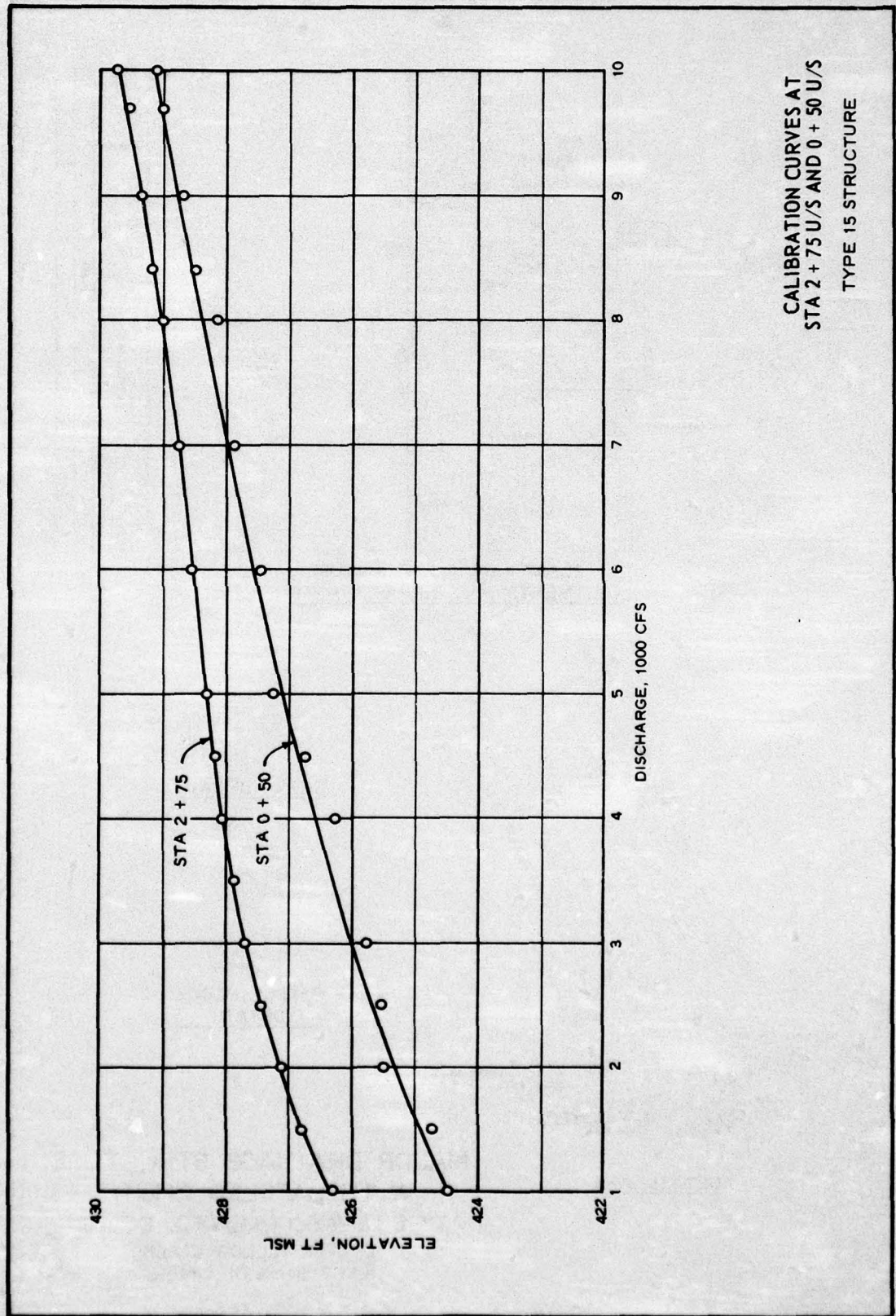

CALIBRATION CURVES AT  
 STA 2 + 75 U/S AND 0 + 50 U/S  
 TYPE 15 STRUCTURE

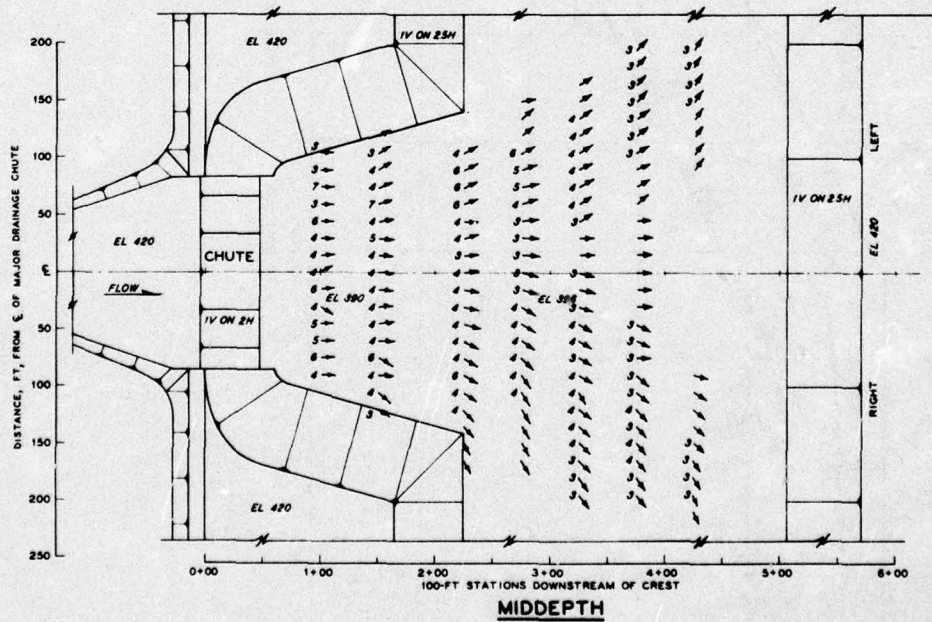
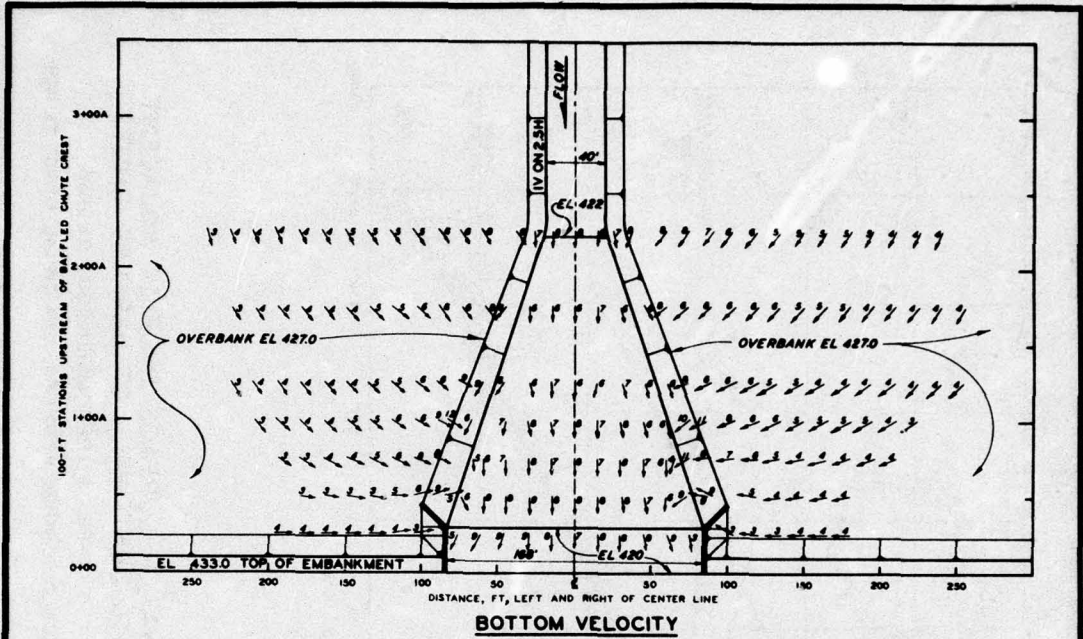

**MIDDEPTH AND BOTTOM  
VELOCITY MEASUREMENTS**

**TYPE 15**  
**DISCHARGE..... 9700 CFS**  
**CANAL STAGE..... 408**

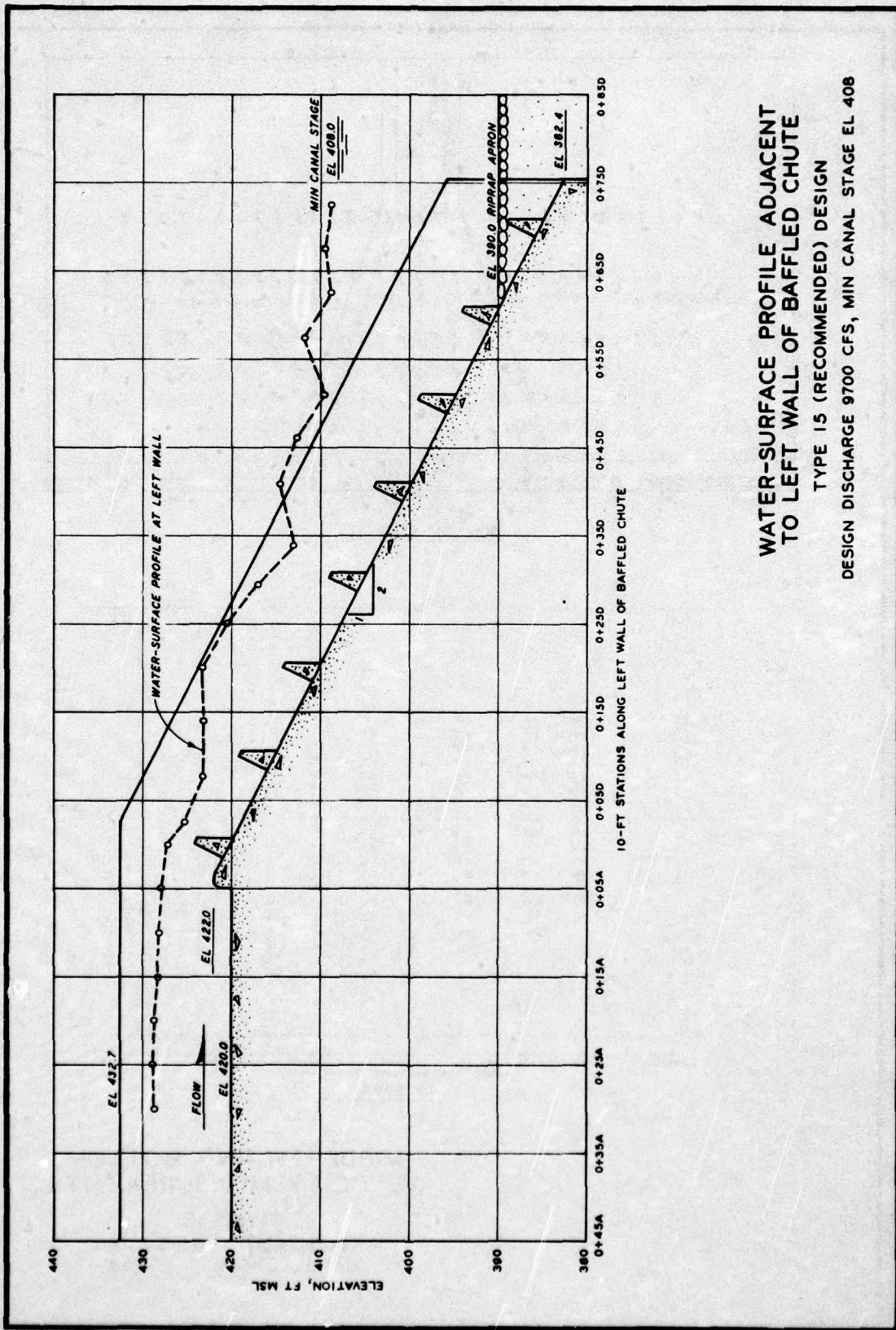

**WATER-SURFACE PROFILE ADJACENT  
TO LEFT WALL OF BAFFLED CHUTE**

TYPE 15 (RECOMMENDED) DESIGN

DESIGN DISCHARGE 9700 CFS, MIN CANAL STAGE EL 408

In accordance with ER 70-2-3, paragraph 6c(1)(b), dated 15 February 1973, a facsimile catalog card in Library of Congress format is reproduced below.

Ables, Jackson H

Divide cut drainage structures, Tennessee-Tombigbee Waterway, Mississippi and Alabama; hydraulic model investigation, by Jackson H. Ables, Jr. Vicksburg, U. S. Army Engineer Waterways Experiment Station, 1976.

1 v. (various pagings) illus. 27 cm. (U. S. Waterways Experiment Station. Technical report H-76-18)

Prepared for U. S. Army Engineer District, Nashville, Nashville, Tennessee.

1. Drainage structures. 2. Tennessee-Tombigbee Waterway. I. U. S. Army Engineer District, Nashville. (Series: U. S. Waterways Experiment Station, Vicksburg, Miss. Technical report H-76-18)  
TA7.W34 no.H-76-18