

AD-A032 679

NAVAL TRAINING EQUIPMENT CENTER ORLANDO FLA
ELECTRONIC CONTROL FOR 360 DEGREE NONPROGRAMMED VISUAL DISPLAY.(U)
NOV 76 J J KULIK, H BERKE

F/6 20/5

UNCLASSIFIED

NAVTRAEQUIPC-IH-267

NL

|OF|
AD
A032679



END
DATE
FILMED
1-77



12

DT

Technical Report: NAVTRAEQUIPCEN IH-267

ELECTRONIC CONTROL FOR 360 DEGREE
NONPROGRAMMED VISUAL DISPLAY

AD A 032679

Electronics and Acoustics Laboratory
Naval Training Equipment Center
Orlando, Florida 32813

November 1976

Interim Report for Period
January 1976 - April 1976

DoD Distribution Statement
Approved for public release;
distribution unlimited.

DDDC
NOV 29 1976
RECEIVED

NAVAL TRAINING EQUIPMENT CENTER
ORLANDO, FLORIDA 32813

Technical Report: NAVTRAEQUIPCEN IH-267

**ELECTRONIC CONTROL FOR 360 DEGREE
NONPROGRAMMED VISUAL DISPLAY**

ACCESSION for		
HTIS	WHY Section	<input checked="" type="checkbox"/>
DOC	Ref. Section	<input type="checkbox"/>
UNREPRODUCED		<input type="checkbox"/>
JUSTIFICATION.....		
BY.....		
DISTRIBUTION/AVAILABILITY CODES		
DIST.	AVAIL.	REPRODUCTION
A		

John J. Kulik
Herbert Berke
Electronics and Acoustics Laboratory

November 1976

GOVERNMENT RIGHTS IN DATA STATEMENT

Reproduction of this publication in whole or in part is permitted for any purpose of the United States Government.

Approved:

M. ARONSON
Head, Electronics and Acoustics Laboratory

Dr. J. F. Harvey
Director, Research and Technology Department

NAVAL TRAINING EQUIPMENT CENTER
ORLANDO, FLORIDA
32813

Unclassified

SECURITY CLASSIFICATION OF THIS PAGE (When Data Entered)

REPORT DOCUMENTATION PAGE		READ INSTRUCTIONS BEFORE COMPLETING FORM	
1. REPORT NUMBER NAVTRAEQUIPCEN IH-267	2. GOVT ACCESSION NO.	3. RECIPIENT'S CATALOG NUMBER	
6. TITLE (and Subtitle) Electronic Control for 360 Degree Nonprogrammed Visual Display.		9. TYPE OF REPORT & DATES COVERED Interim <i>Kept.</i> Jan 1976 - Apr 1976	
		6. PERFORMING ORG. REPORT NUMBER NAVTRAEQUIPCEN IH-267	
7. AUTHOR(s) 10. John J. Kulik Herbert Berke		8. CONTRACT OR GRANT NUMBER(s)	
9. PERFORMING ORGANIZATION NAME AND ADDRESS Department of the Navy Naval Training Equipment Center Orlando, Florida 32813		10. PROGRAM ELEMENT, PROJECT, TASK AREA & WORK UNIT NUMBERS NAVTRAEQUIPCEN Task No. 7719	
11. CONTROLLING OFFICE NAME AND ADDRESS Department of the Navy Naval Training Equipment Center Orlando, Florida 32813		12. REPORT DATE 11. November 1976	12. NUMBER OF PAGES 24 p.
13. MONITORING AGENCY NAME & ADDRESS (if different from Controlling Office) 14. NAVTRAEQUIPC-IH-267		13. SECURITY CLASS. (of this report) Unclassified	
15. DECLASSIFICATION/DOWNGRADING SCHEDULE			
16. DISTRIBUTION STATEMENT (of this Report) Approved for public release; distribution unlimited.			
17. DISTRIBUTION STATEMENT (of the abstract entered in Block 20, if different from Report)			
18. SUPPLEMENTARY NOTES			
19. KEY WORDS (Continue on reverse side if necessary and identify by block number) Charge coupled devices, visual display, training device			
20. ABSTRACT (Continue on reverse side if necessary and identify by block number) An electronic control system is designed for a 360 degree nonprogrammed visual display. Synchronizing signals for various system components are developed based on an analysis of the system requirements. Discussion of state-of-the-art logic required is given and detailed circuitry is shown for system implementation.			

DD FORM 1473 1 JAN 73

EDITION OF 1 NOV 65 IS OBSOLETE
S/N 0102-014-6601

Unclassified

SECURITY CLASSIFICATION OF THIS PAGE (When Data Entered)

390 462

Y/B

D D C
NOV 29 1976
RECEIVED

NAVTRAEQUIPCEN IH-267

TABLE OF CONTENTS

<u>SECTION</u>		<u>PAGE NO.</u>
I	INTRODUCTION	3
II	STATEMENT OF THE PROBLEM	3
III	SYSTEM ANALYSIS	4
IV	CONCLUSIONS	8
V	RECOMMENDATIONS	8
	APPENDIX A, CCD CLOCKING	17
	APPENDIX B, CCD LOADING	19
	APPENDIX C, BANDWIDTH REQUIREMENTS	20
	APPENDIX D, POWER SUPPLY REQUIREMENT PER SYSTEM	21

NAVTRAEQUIPCEN IH-267

LIST OF ILLUSTRATIONS

<u>FIGURE</u>		<u>PAGE NO.</u>
1	Pick-up Display System Using CCD Sensors and Laser Display System for 360 Degree Cylindrical Display	5
2	Electronic Control System	6
3	Timing Diagram	9
4	Typical Propagation Delays	10
5	Drive Circuit	11
6	Counter Circuit	12
7	Driver Stages	13
8	Flip Flop and Gates	14
9	Dual One-Shot and Output Amplifier	15
10	CCD 21	16

NAVTRAEQUIPCEN IH-267

SECTION I

INTRODUCTION

Research and Technology Task No. 7719, 360 Degree Nonprogrammed Visual Display, calls for the fabrication of a feasibility model of a 360 degree non-programmed visual display. The display relies on a group of 12 charge coupled device (CCD) linear arrays as pickup devices and 12 lasers as output devices. Various rotating components are also incorporated in the system. In order that the CCD arrays, lasers, and rotational system components work together properly, they must be synchronized. The design of an electronic control system providing synchronizing signals to the display system components is presented in this report. A display system analysis yields the required frequency of the master clock and countdown circuits are determined for the various components which require synchronization. Conclusions are reached regarding the confidence level of the electronic control system, since the frequencies required demand the use of state-of-the-art logic. Recommendations are made on an alternative lower frequency and the effect of lower frequency clocks on the original system is given.

SECTION II

STATEMENT OF THE PROBLEM

Design electronic control circuits to provide common synchronizing pulses to the pickup elements (CCDs), the display elements (lasers), and the rotational elements which provide the vertical and horizontal sweeps to the scanning and writing beams.

NAVTRAEQUIPCEN IH-267

SECTION III

SYSTEM ANALYSIS

The block diagram in figure 1 shows the pickup-display system. The electronic control system must provide synchronous clocking pulses to control (1) CCD outputs, (2) the laser scanner, (3) rotation prism, and (4) dero-rotation prism noted in figure 1. A video amplifier to provide modulation signals to the laser modulator is also required. The fundamental requirements fixing the clock frequencies for the electronic control system are:

- a. Three minutes of arc between raster lines
- b. Thirty Hertz frame rate
- c. Two to one interlace
- d. Twelve CCD line sensors and 12 laser line outputs

Since there are 360 degrees in the display,

then

$$(360 \times 60)/3 = 7200 \text{ lines are required per frame}$$

Since there are 12 CCDs (and lasers)

$$7200/12 = 600 \text{ lines}$$

per CCD are required per frame. Since the frame rate is 30 Hertz, and the number of pixels per CCD is 1728

$$600 \times 30 \times 1728 = 31.104 \text{ MHz}$$

is required clock frequency to pulse out the video from the CCDs. Since some transfer time (about 2,000 nanoseconds) is needed to transfer the charge into the shift register, the required clock frequency is about 32 MHz. Since 32 MHz is the highest required frequency, the minimum input master clock is 64 MHz.

The laser scanner is a twelve faceted mirror each of which puts out 12 lines per revolution - 144 lines in all.

Since

$$7200 \times 30 = 216,000$$

lines are required, the laser scanner must rotate at

$$21600/144 = 1500$$

revolutions per second or 90,000 revolutions per minute. The nearest

NAVTRAEQUIPCEN IH-267

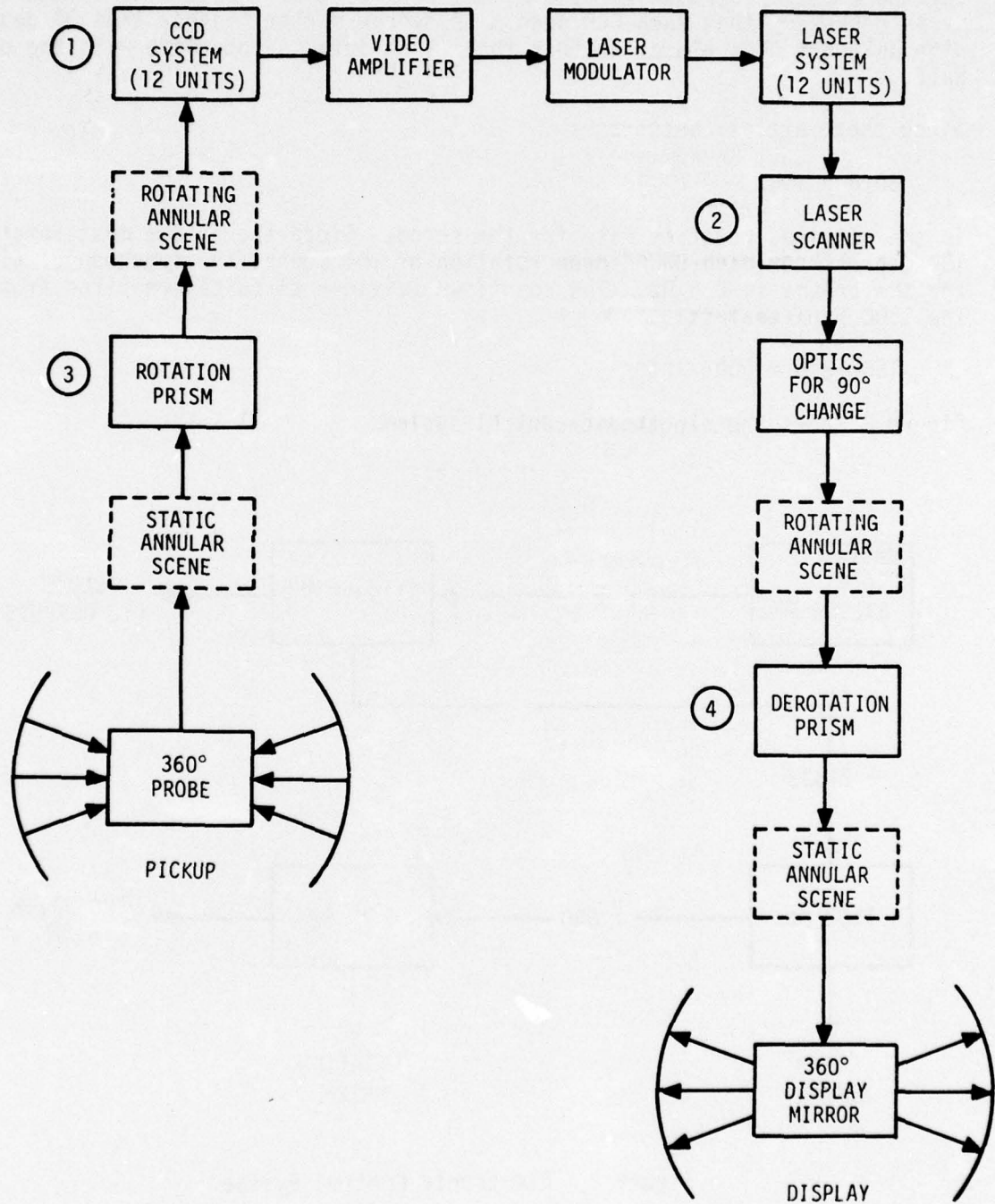

Figure 1. Pick-up Display System Using CCD Sensors and Laser Display System For 360° Cylindrical Display

NAVTRAEQUIPCEN IH-267

Integral dividend to 32 MHz, which will yield 1500 rps, is 31.9995 MHz. That is, if we divide 31.9995 MHz by 21333, the result is 1500 Hz which will be the synchronizing signal for the rotating laser scanner. Synchronizing signals for the rotation/derotation prisms must be provided. For a 2 to 1 interlace, it is necessary that each CCD scan a 60 degree sector (rather than 30 degree) with half the CCDs placed so that their line outputs interlace with the other half.

Since there are six sectors

$$30/6 = 5 \text{ Hz}$$

is the required rotation rate for the scene. Since the prisms must rotate 180 degrees for each 360 degree rotation of the scene, the synchronous signal for the prisms is 2.5 Hz. The countdown (divider circuits) required from the 1500 Hz signal is

$$1500/2.5 = 600$$

Figure 2 shows the electronic control system.

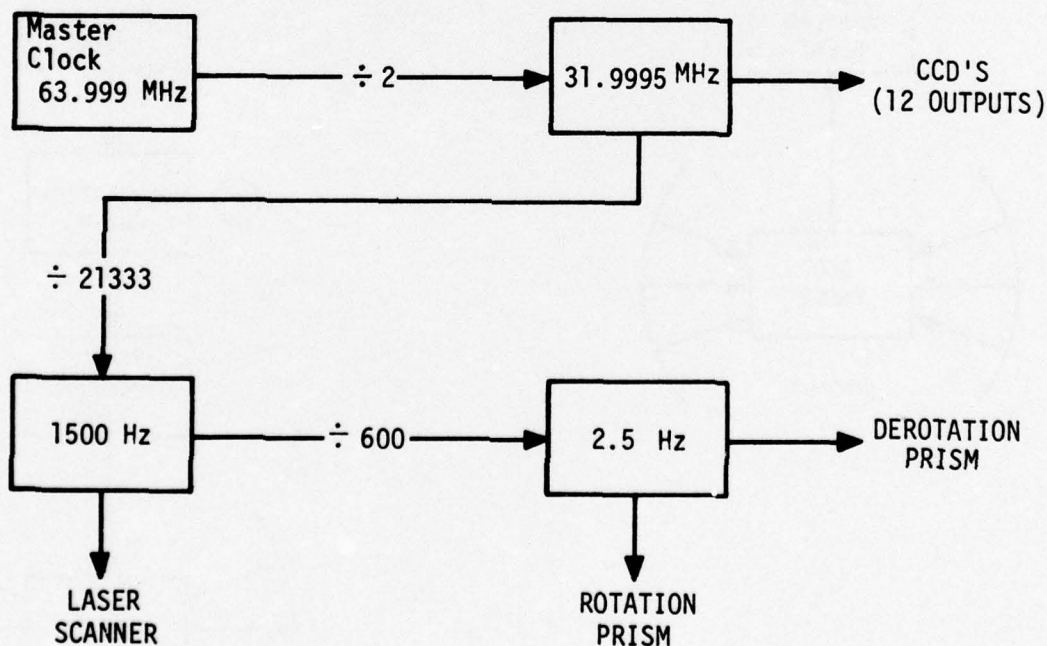

Figure 2. Electronic Control System

NAVTRAEQUIPCEN IH-267

Detailed circuitry will be shown using a 60 MHz master clock. Sixty MHz is used as an example because of the inability to forecast the exact rotation rate of the laser scanner (90,000 rpms in exercise above) to be delivered from the manufacturer.

The high-clocking requirements of this design produce pulses with time lengths in the area of the propagation delays of state-of-the-art logic. The only possible choices of logic which can be used are:

- a. Emitter Coupled Logic (ECL) - smallest propagation delay, 2-3 ns
- b. Schottky - propagation delay 5 - 10 ns.

ECL voltage level is not compatible with that of other circuitry that must be used so Schottky logic must be used.

Once the choice was made to use Schottky logic, a study of each chip was made for propagation delays versus the final clocking requirements. This is shown in figures 3 and 4. Figure 3 is a timing diagram of the clocking required for the charge coupled device, CCD 121. Figure 4 shows the typical delay error due to propagation times.

Figure 5 is a block diagram of the drive circuit and shows the gates that can be introduced to correct the delay error shown in figure 4.

- a. Counters A, B, and C are included in this design to have the option of a synchronous or asynchronous system. With the switch on EXT. START, a command-pulse from an external source controls the read cycle. With the switch on FREE-RUN, a new cycle is initiated at the end of the 1728 element readout from the counters.

- b. The five drive clocks are $\phi 1$, $\phi 2$, ϕR , ϕXA , ϕXB . The correct sequence of the clocks is shown in figure 3.

- c. A decision was made to use one clock source for all the drive circuitry to keep any error down to a minimum. A 15 MHz clock is available for the mirror and prism drive systems. This clock can be divided down to the frequencies that are required by the manufacturers of these systems. This still has to be looked into to determine what type of motor drive circuitry is required.

Figures 6 through 9 describe the detailed circuitry required for the CCD clocking and output amplifier.

Figure 10 shows the CCD chip and external connections.

Appendix A is an analysis of the minimum input clock that is required for a resolution of three minutes and four minutes between scan lines. The operation of the CCD 121 is going to be borderline at these clocking rates and may present a problem of integration time, i.e., the time allowed for the photosites to collect charge. If the time is too short, the output signal may be very low and difficult to pull out of the dark-signal noise. The output amplifier is a low noise type with a variable gain and can be

NAVTRAEQUIPCEN IH-267

trimmed for higher output signals.

Appendix B details the CCD 121 loading requirements at the required clocking rate. Peak currents of 700 ma must be considered for the power supply requirements.

Appendix C details the bandwidth requirement for the amplifier system and laser modulator. A minimum bandwidth of 40 MHz would be a safe figure to use for the specifications when purchasing the modulator and modulation drive amplifier.

Appendix D details the power supply requirements and the voltage regulators to be used. The current drain is for one complete CCD 121 system. If there will be 12 CCDs, it is recommended that three power supplies per system be purchased.

The clocking system, CCD 121 Chip, and the output amplifiers, should be contained on a printed circuit board that is designed for high frequency operation. The board should have a ground plane, a Vcc plane, and use decoupling capacitors; 0.047 μ f mounted next to each logic chip and 10 μ f for each voltage source. Due to the high frequency requirements, the design of this board should be carefully planned by someone with expertise in board layouts.

SECTION IV

CONCLUSIONS

An electronic control circuit is required for the synchronous operation of the CCDs, the laser scanner, and the rotation-derotation prisms of the 360 degree visual display system. The master clock frequency of approximately 60 MHz demands the use of state-of-the-art Schottky logic. The high frequency required may degrade the performance of the CCD arrays to the point where a relaxation of the display system requirements will be necessary. Appendix A gives the frequencies for a three minute arc separation and those for a four minute arc separation. Since both these separations are better than currently available on wide angle visual systems, further relaxation for a feasibility model does not seriously affect a decision to proceed with the project.

SECTION V

RECOMMENDATIONS

It is recommended that consideration be given to using a less stringent requirement than three minutes of arc separation of the TV raster lines due to the critical propagation delays of the clocking circuitry. It is recommended that personnel of the Electronics and Acoustics Laboratory be kept informed of the progress in purchasing the various system components so that testing and system design can be continually updated as necessary as purchases are made.

NAVTRAEQUIPCEN IH-267

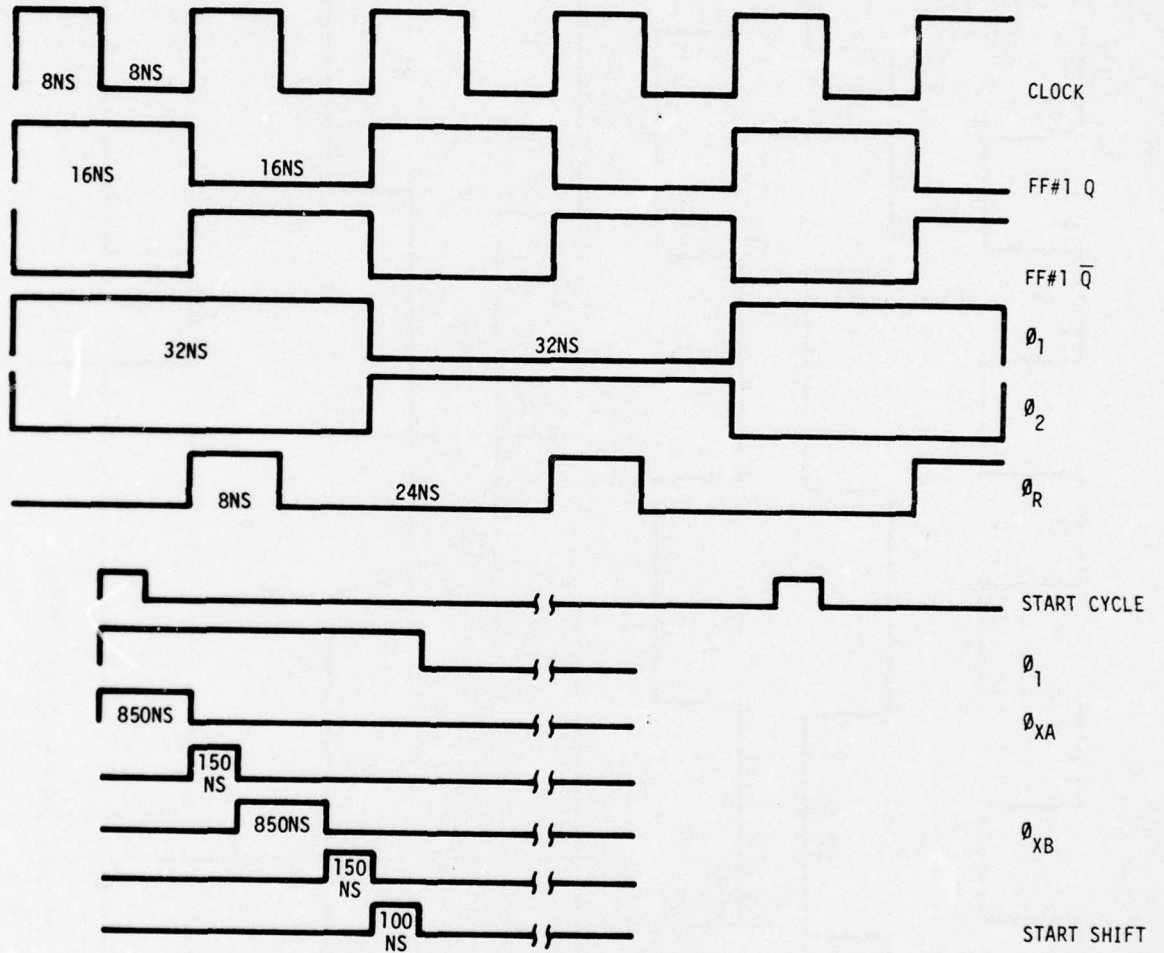

Figure 3. Timing Diagram

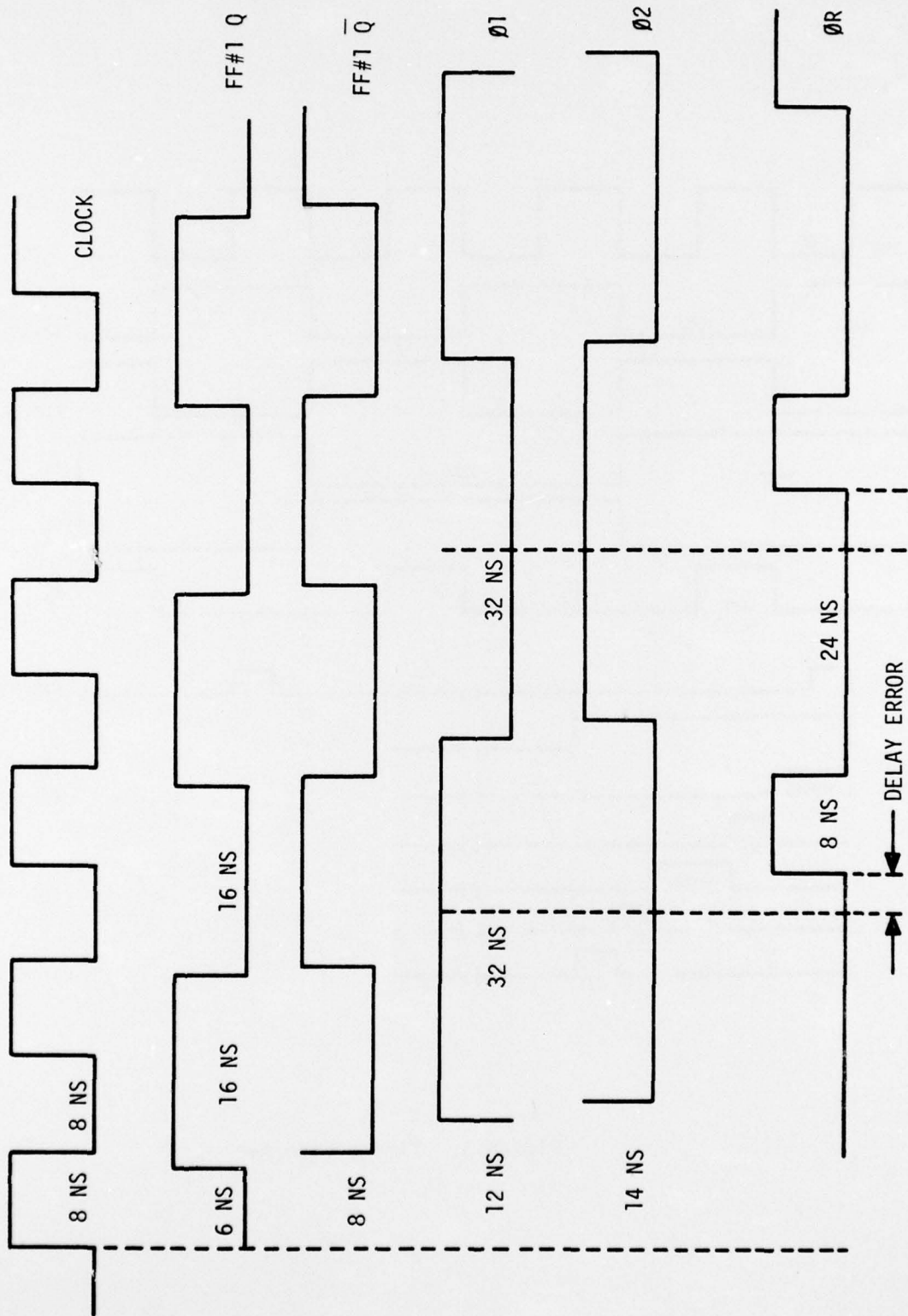

Figure 4. Typical Propagation Delays

NAVTRAEQUIPCEN IH-267

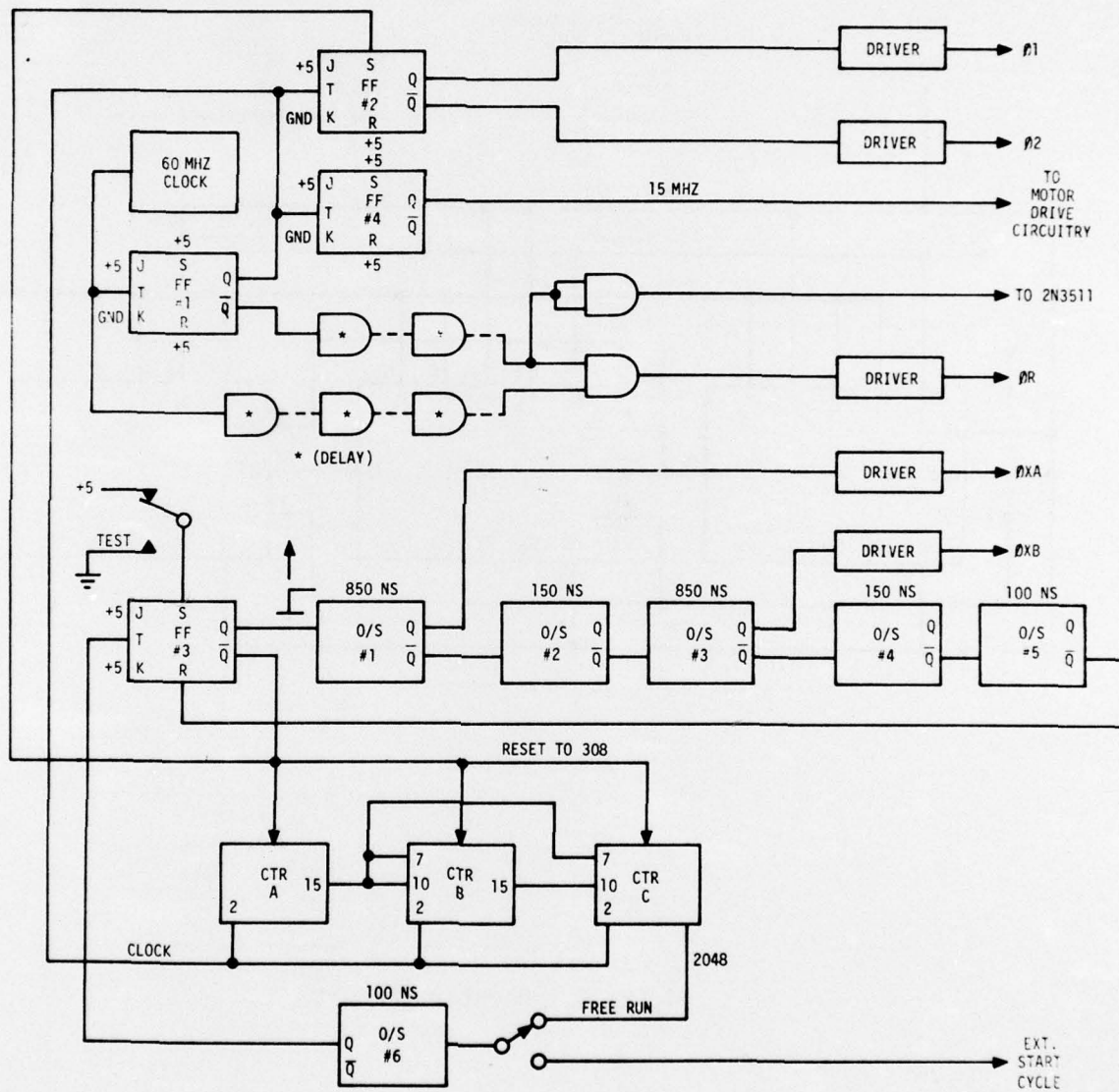

Figure 5. Drive Circuit

NAVTRAEQUIPCEN IH-267

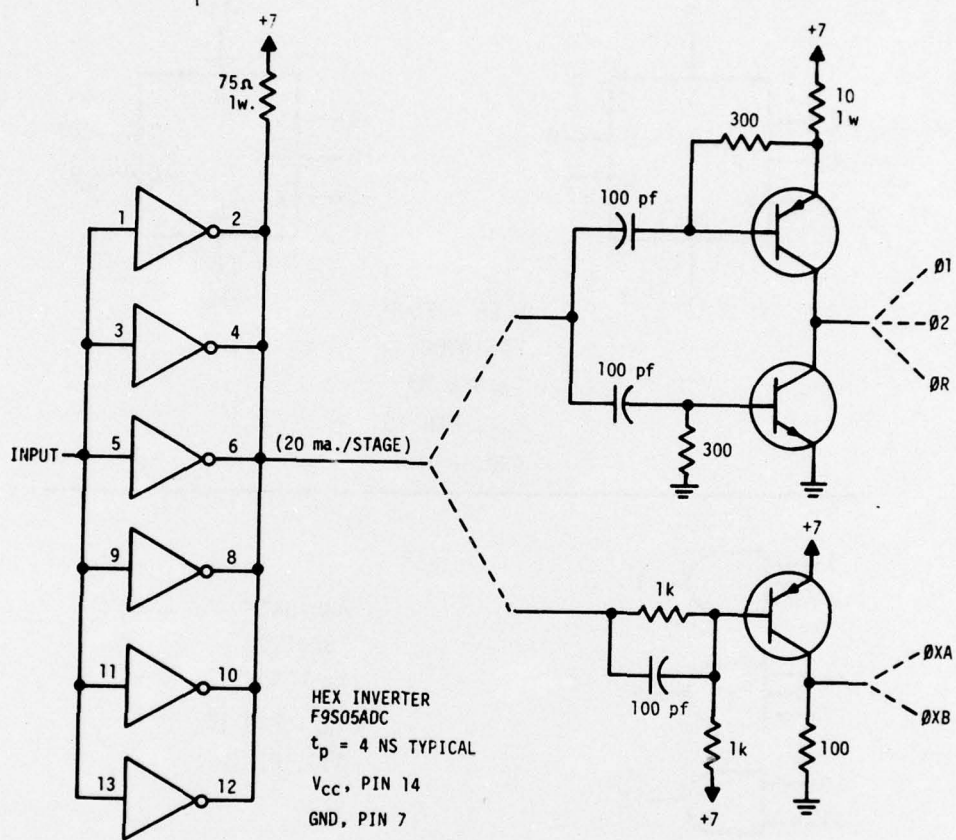
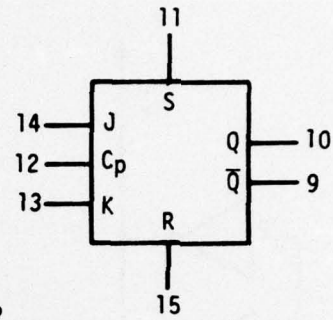
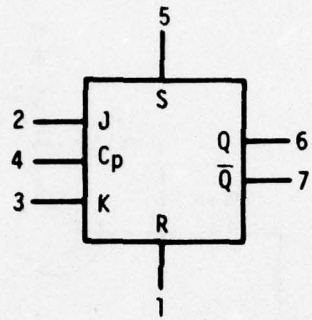
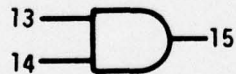
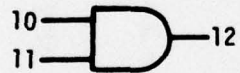
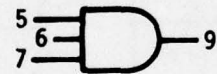
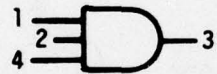

Figure 7. Driver Stages

NAVTRAEQUIPCEN IH-267



FLIP - FLOP
 F9S109DC
 $t_p \approx 8 \text{ NS}$
 V_{CC} , PIN 16
 GND, PIN 8



AND-GATE
 F9S41DC
 $t_p \approx 5 \text{ ns}$
 V_{CC} , PIN 16
 GND, PIN 8

Figure 8. Flip Flip and Gates

NAVTRAEQUIPCEN: IH-267

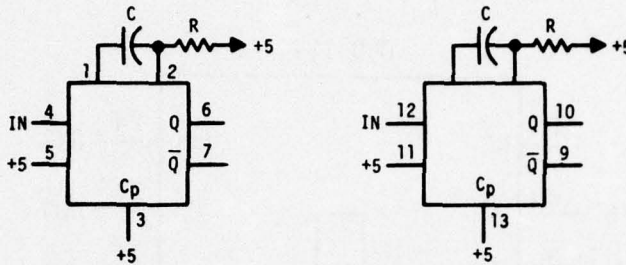

DUAL ONE-SHOT
9602 DC

Vcc, PIN 16 (*USE 0.01 μ f CAP. BETWEEN Vcc & GND)
GND, PIN 8

- | | |
|---------------|----------------------|
| 1. T = 850 ns | R = 27k, C = 100 pf |
| 2. T = 150 ns | R = 7.5 k, C = 22 pf |
| 3. T = 100 ns | R = 5 k, C = 22 pf |

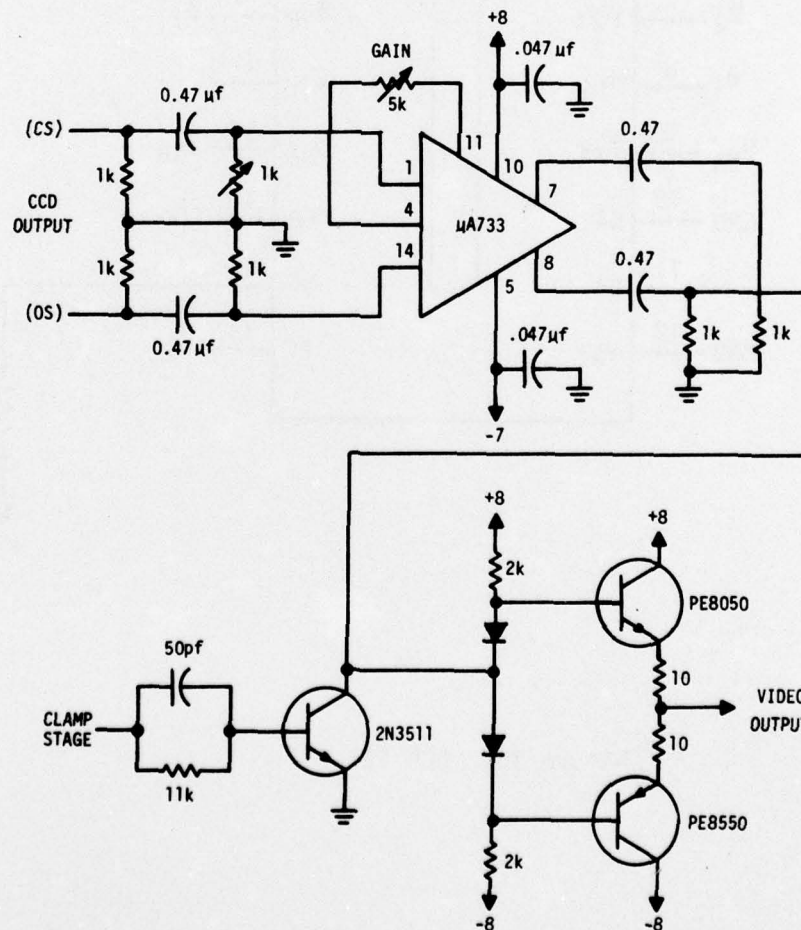

Figure 9. Dual One-Shot and Output Amplifier

NAVTRAEQUIPCEN IH-267

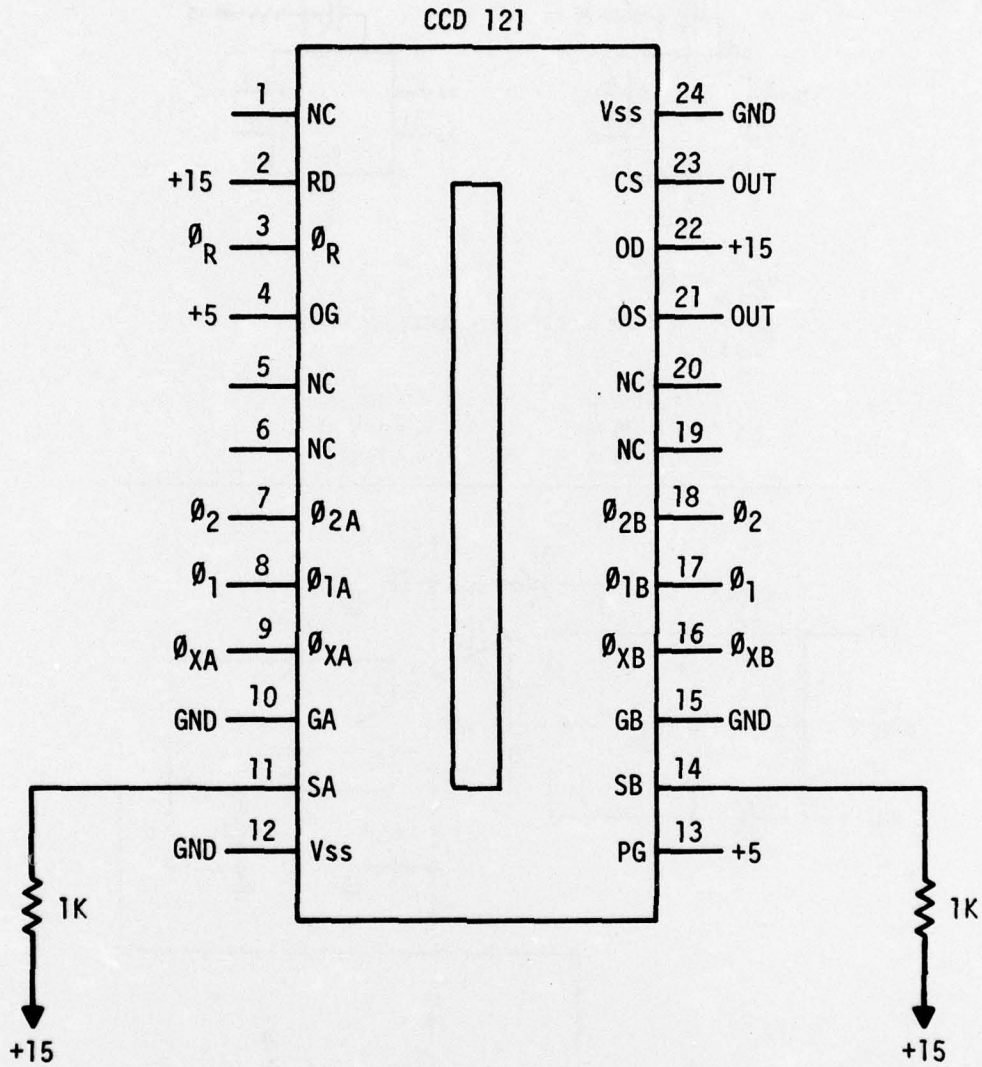
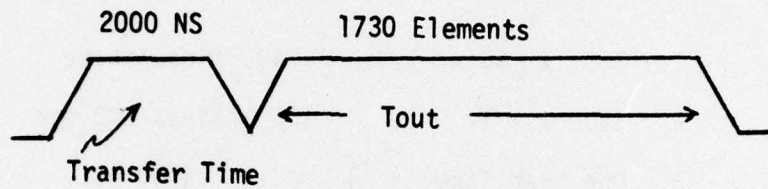

Figure 10. CCD 121

NAVTRAEQUIPCN IH-267

APPENDIX A
CCD CLOCKING

Total Scan Time



- I. Required: 3 minute resolution between lines
30 frames /sec
12 CCD's /frame

1. $360^\circ \times 60 \frac{\text{min}}{\text{Deg}} \times \frac{1 \text{ line}}{3 \text{ min}} = 7200 \text{ lines/frame}$
2. $7200 \text{ lines/frame} \times \frac{1 \text{ frame}}{12 \text{ CCD's}} \times 30 = 18\text{K} \frac{\text{lines}}{\text{CCD Sec}}$
3. Time for 1 total CCD scan = $\frac{1}{18\text{K}} = 5556 \text{ NS}$
4. $T_{\text{out}} = \text{Total scan} - 200 \text{ ns} = 53556 \text{ ns}$
5. Clocking rate: $\frac{1730}{T_{\text{out}}} = 32 \text{ MHz}$
6. Minimum Input clock is 64 MHz

NAVTRAEQUIPCEN IH-267

APPENDIX A (Cont)

II. Required: 4 Minute Resolution

1. $360 \times 60 \times 1/4 = 5400$ lines/frame
2. $5400 \times 1/12 \times 30 = 13500$ lines/CCD sec
3. One Scan Time = $\frac{1}{13500} = 74000$ ns
4. $T_{out} = 72000$ ns
5. Clock rate: $\frac{1730}{72000 \text{ NS}} = 24$ MHz
6. Minimum Input Clock = 48 MHz

NAVTRAEQUIPCEN IH-267

APPENDIX B

CCD LOADING

$$C\theta_r = 1 \text{ pf load}$$

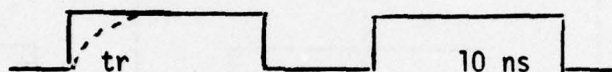

$$\text{Trise} = 2.2 RC$$

1. Let $tr = 2.2 \text{ ns} = 2.2 RC$

$$R = \frac{1 \text{ ns}}{C} = 1000 \text{ ohms}$$

$$I_{\text{peak}} = \frac{7V}{TK} = 7 \text{ ma}$$

2. $C\theta_1 = C\theta_2 = C\theta_x = 400 \text{ pf}$

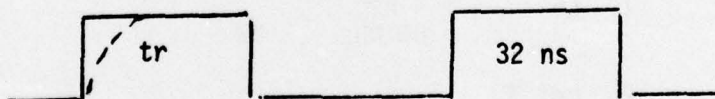

Let $tr = 10 \text{ ns} = 2.2 RC$

$$R = \frac{5 \text{ ns}}{C} \approx 12 \text{ ohms}$$

$$I_{\text{peak}} = \frac{7}{12} \approx 700 \text{ ma}$$

NAVTRAFQUIPCEN IH-267

APPENDIX C

BANDWIDTH REQUIREMENTS

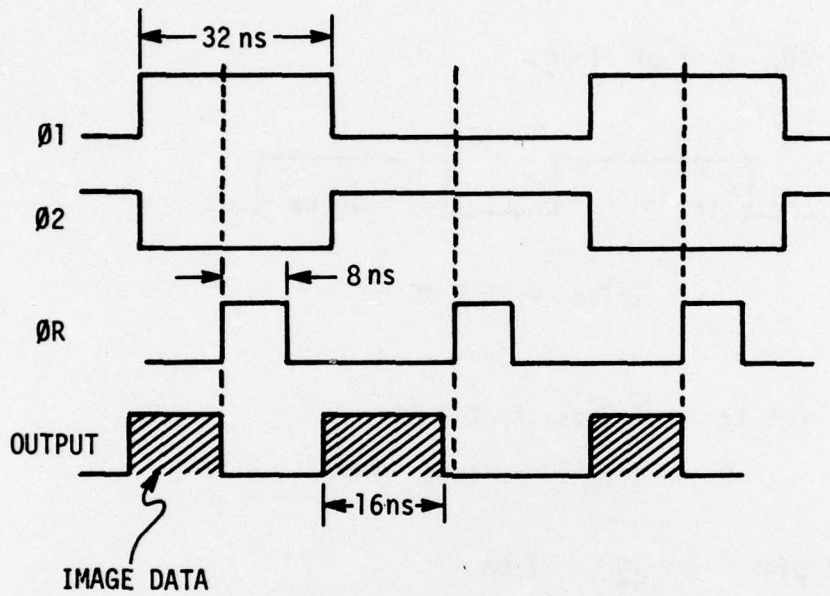

$$T_{rise} = 2.2 RC = \frac{1}{3f}$$

1. Let $T_r = 4 \text{ ns}$
 $f = 80 \text{ MHz}$ BW
2. Let $T_r = 8 \text{ ns}$
 $F = 40 \text{ MHz}$ BW

NAVTRAEQUIPCEN IH-267

APPENDIX D

POWER SUPPLY REQUIREMENT PER SYSTEM

I. Logic Circuitry:

$V_{cc} = +5 \text{ V}$
 $I_{\text{Drain}} = 700 \text{ ma}$

II. Drivers and Output Amplifier

a. $E_i = +15 \text{ V}$
 $V_{cc} = +8 \text{ V}$
 $I_D = 1 \text{ A.}$

Device: $\mu \text{ A } 7808 \text{ UC}$
* Use 10W Heat Sink

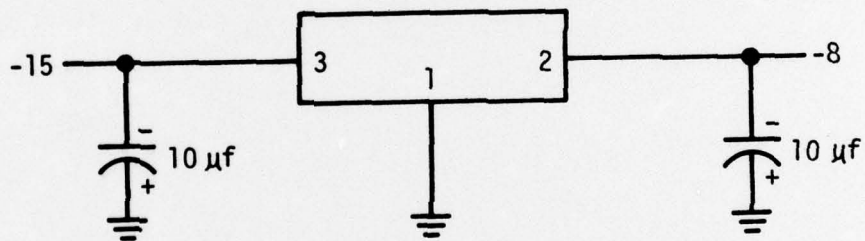

b. $E_i = -15 \text{ V}$
 $V_{cc} = -8 \text{ V}$
 $I_D = 300 \text{ ma}$

Device: $\mu \text{ A } 7908 \text{ UC}$
* Use 10 W. Heat Sink

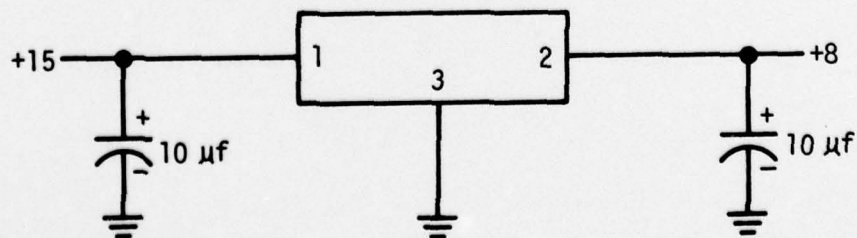

NAVTRAFQUIPCEN IH-267

DISTRIBUTION LIST

Commanding Officer
Naval Training Equipment Center
Orlando, Florida 32813 (28)

Defense Documentation Center
Cameron Station
Alexandria, Virginia 22314 (12)

Naval Electronics Systems Command
Attn: L. Sumney
Washington, D. C. 20360 (1)

Naval Electronics Systems Command
Attn: N. Butler
Washington, D. C. 20360 (1)

Naval Electronics Systems Command
Attn: John Merz
Washington, D. C. 20360 (1)