

AD-AU32 721

ARMY COMMUNICATIONS-ELECTRONICS ENGINEERING INSTALLAT--ETC F/G 17/2.1
DEB STAGE 1 CONUS LINK TESTING INTERIM REPORT.(U)
OCT 76 J J MCDONNELL, E NEW, S T SCHOCH

UNCLASSIFIED

CCC-CED-76-DTEP-014

NL

| OF |
AD
A032721



END

DATE
FILMED
1-77

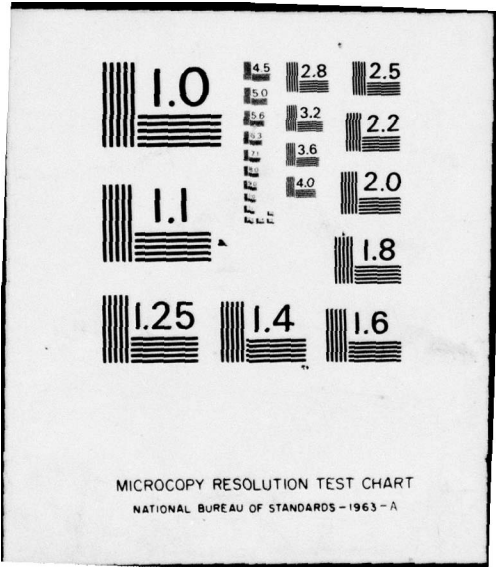

MICROCOPY RESOLUTION TEST CHART
NATIONAL BUREAU OF STANDARDS-1963-A

ADA 032721

CCC-CED-76-DTEP-014

15

DEB STAGE 1-COMUS LINK TESTING
INTERIM REPORT

CPT JOHN J. McDONNELL
CPT EDWARD NEW
SFC STEPHEN T. SCHOCH

DDC
DEC 2 1976
C

OCTOBER 1976

Approved for public release; distribution unlimited

HEADQUARTERS
US ARMY COMMUNICATIONS-ELECTRONICS ENGINEERING INSTALLATION AGENCY
Fort Huachuca, Arizona 85613

DISTRIBUTION STATEMENT

Approved for public release.

Distribution unlimited.

DISPOSITION INSTRUCTIONS

Destroy this document when no longer needed.

Do not return it to the originator.

DISCLAIMER

The findings in this report are not to be construed as an official Department of the Army position unless so designated by other authorized documents.

The use of trade names in this document does not constitute an official endorsement or approval of the use of such commercial hardware or software. This document may not be cited for purpose of advertisement.

ERRATA SHEET

DD Form 1473, Block 11 - Change to read:

U.S. Army Communications Command
DCS for Operations and Plans (CC-OPS)
Ft. Huachuca, Arizona 85613

Page 36: AFCS/EPS ----- 2
Change to read:

AFCS/EPPD ----- 2
AFCS/DOYT ----- 2
1842 EEG/DCTE ----- 2
1842 EEG/DCIM ----- 2

Page 37: USACC, ATTN: CC-FD-MMR ---- 4
ATTN: CC-POA-SM ---- 2
Change to read:

USACC, ATTN: CC-OPS-SM ---- 4
ATTN: CC-OPS-ST ---- 2

USACSA, ATTN: CCM-EU-ED --- Delete

Add: ESD, ATTN: DCF
Hanscom AFB, Mass ----- 2
01731

UNCLASSIFIED

SECURITY CLASSIFICATION OF THIS PAGE (When Data Entered)

REPORT DOCUMENTATION PAGE		READ INSTRUCTIONS BEFORE COMPLETING FORM
1. REPORT NUMBER CCC-CED-76-DTEP-014	2. GOVT ACCESSION NO.	3. RECIPIENT'S CATALOG NUMBER
4. TITLE (and Subtitle) DEB Stage 1 CONUS LINK TEST, INTERIM REPORT		5. TYPE OF REPORT & PERIOD COVERED Interim Report for May - Sep 1976
7. AUTHOR CPT John J. McDonnell, CPT Edward New SFC Stephen T. Schoch		6. CONTRACT OR GRANT NUMBER(s)
9. PERFORMING ORGANIZATION NAME AND ADDRESS US Army Communications-Electronics Engineering Installation Agency and US Army Electronic Proving Ground, Fort Huachuca, Arizona 85613		10. PROGRAM ELEMENT, PROJECT, TASK AREA & WORK UNIT NUMBERS
11. CONTROLLING OFFICE NAME AND ADDRESS U.S. Army Communications Command, DCSOPS, Vice Assistant Chief of Staff for Force Development, Fort Huachuca, Arizona 85613		12. REPORT DATE 29 October 1976
14. MONITORING AGENCY NAME & ADDRESS (if different from Controlling Office) US Army Communications Systems Agency Fort Monmouth, NJ 07703		13. NUMBER OF PAGES 41
		15. SECURITY CLASS. (of this report) UNCLASSIFIED
		15a. DECLASSIFICATION/DOWNGRADING SCHEDULE
16. DISTRIBUTION STATEMENT (of this Report) Approved for public release, distribution unlimited.		
17. DISTRIBUTION STATEMENT (of the abstract entered in Block 20, if different from Report)		
18. SUPPLEMENTARY NOTES To be entered in Defense Documentation Center.		
19. KEY WORDS (Continue on reverse side if necessary and identify by block number) microwave communications digital transmission 3-level partial response duo-binary biternary		
20. ABSTRACT (Continue on reverse side if necessary and identify by block number) CONUS link testing was initiated to establish a data base and performance assessment of a similar microwave system in advance of the final implementation of the DEB Stage-1 program. Six AN/FRC 162 radios, two AN/FRC 165 radios, and ten T1-4000 multiplexers were used to establish four terminals with the capability of propogating over eight paths, one of which had a length of 82 miles. Mathematically predicted fade margins were not realized. A large difference was noted in the number of fades recorded at each terminal receiver, over one path.		

DD DC
 RECEIVED
 DEC 2 1976
 C

over

A noteworthy number of fade rates in excess of 70 dB/second was observed, and over 0.5% of recorded fade depths were 30 dB or greater. Except for four drop-outs, the long term BER for the 82-mile link was 1.4×10^{-12} . The BER was 1.85×10^{-8} after eight transmission links of baseband repeaters, but with a 10 dB fade margin. Variability among multiplexer sensitivities was important in determining the distribution of errors in the baseband repeater tests.

10 to the minus 8th power

10 to the minus 12th power

ACCESSION	<input checked="" type="checkbox"/>
RTIS	<input type="checkbox"/>
E.O.	<input type="checkbox"/>
UNCLASSIFIED	<input type="checkbox"/>
INSTRUMENTATION	
BY	
EXEMPTION/AVAILABILITY CODES	
DATE OF SPECIAL	
A	

TABLE OF CONTENTS

<u>PARAGRAPH</u>	<u>PAGE</u>
1. BACKGROUND	
1.1 Introduction	1
1.2 Approach to the Task	1
1.3 General Test Objectives	7
1.4 Summary of Findings	7
2. GENERAL	
2.1 Description of Equipment	9
2.2 Summary of AN/FRC 162 Test Results	9
2.3 Test Methodology and Limitations	11
2.4 Unscheduled Test Observations	11
3. DETAILS OF TESTING	
3.1 Received Signal Levels: Predicted vs Actual	15
3.2 Path Fading: Depth, Rate, and Duration	18
3.3 Bit Error Rate vs Received Signal Level	20
3.4 Baseband Repeater Operation	21
3.5 Multiplexer Performance	30
<u>APPENDICES</u>	
A. Terminal Equipment Specifications	32
B. Mule Mountain - Mount Lemmon Path Profiles	33

LIST OF ILLUSTRATIONS

<u>FIGURE</u>	<u>PAGE</u>
1. Simplified Map: 82-Mile Link	2
2. Photograph of Mount Lemmon Microwave Site	3
3. Photograph of Mule Mountain Microwave Site	4
4. Photograph of Site Sibyl	5
5. Photograph of CTA Microwave Site	6
6. AN/FRC 162 Bit Error Rate vs Received Signal Level Characteristic Curves	10
7. AN/FRC 162 Bit Error Rate vs Unavailability	12
8. Typical Characteristics of Noise Power Ratio vs Input Loading	14
9. Test Configuration for Received Signal Level Measurement	16
10. Predicted vs Actual Received Signal Level Relationship .	17
11. Test Configuration for Baseband Repeater Operation	22
12. Eight-Hop Transmission Diagrams	23
13. Baseband Frequency Response Characteristics for 8-Hop Transmission	25
14. Baseband Frequency Response Characteristics for 1, 2, 3, and 4-Hop Transmissions	26
15. Oscillographs of Eye Patterns for Baseband Repeater Operation	27
16. Part I-Oscillographs of Sequential Baseband Spectra (Repeater Operation)	28
16. Part II-Oscillographs of Sequential Baseband Spectra (Repeater Operation)	29
17. Mule Mountain-Mount Lemmon Path Profile (K=4/3).....	33
18. Mule Mountain-Mount Lemmon Path Profile (K=3/3).....	34
19. Mule Mountain-Mount Lemmon Path Profile (K=2/3).....	35

LIST OF TABLES

<u>TABLE</u>		<u>PAGE</u>
1.	Microwave Paths and Lengths	1
2.	Long Link Fade Rates	19
3.	Long Link Fade Depths	19
4.	Long Link Fade Durations	20
5.	Received Signal Level Distribution During Bit Error Rate Measurements	21
6.	Baseband Repeater Performance	24
7.	Terminal Equipment Specifications	32

1. BACKGROUND.

1.1 Introduction.

1.1.1 This document reports the results of tests performed on the Defense Communication System (DCS) microwave radio system modified for three-level partial response, operated over multiple-hop microwave links. The US Army Communications-Electronics Engineering Installation Agency (USACEEIA) was assigned the task of establishing a four-path microwave complex, including an 80-mile line-of-sight link to collect propagation and system engineering data in support of the Digital European Backbone (DEB) Stage I Program. This system was tested as part of the US Army Communications Command (USACC) Digital Transmission Evaluation Project (DTEP) during the period of May to October 1976.

1.1.2 USACEEIA was authorized to perform this mission by Department of the Army message, DAMO-TSC-T, 272145Z June 1975; and U.S. Army Communications Systems Agency (USACSA) message, CCM-SP-C, 251936Z July 1975. USACSA, Fort Monmouth, New Jersey, is responsible for managing the DTEP. Conduct of the tests was tasked to the US Army Electronic Proving Ground (USAEPG), Fort Huachuca, Arizona, under the technical guidance and supervision of USACEEIA, Fort Huachuca, Arizona.

1.2 Approach to the Task.

1.2.1 Some DEB microwave links exceed 50 miles in length and cover mountainous terrain. To simulate this condition work was initiated in July 1975 and completed in May 1976 establishing a terminal at Mount Lemmon near Tucson, Arizona, and a second terminal at Mule Mountain near Bisbee, Arizona. These terminals were integrated with two other sites at Fort Huachuca (CTA), and Benson, Arizona (Site Sibyl). Figure 1 is a simplified map which illustrates the geometrical, topographic configuration of the four terminals. Table 1 lists the four microwave paths and their respective lengths in miles. Figures 2 through 5 are photographs of each of the four terminals used in this study.

Table 1. Microwave Paths and Lengths

<u>PATH</u>	<u>DISTANCE</u>
CTA - Site Sibyl.	32.1 miles
Site Sibyl - Mount Lemmon	47.3 miles
Mule Mountain - Mount Lemmon.	82.0 miles
Mule Mountain - CTA	23.7 miles

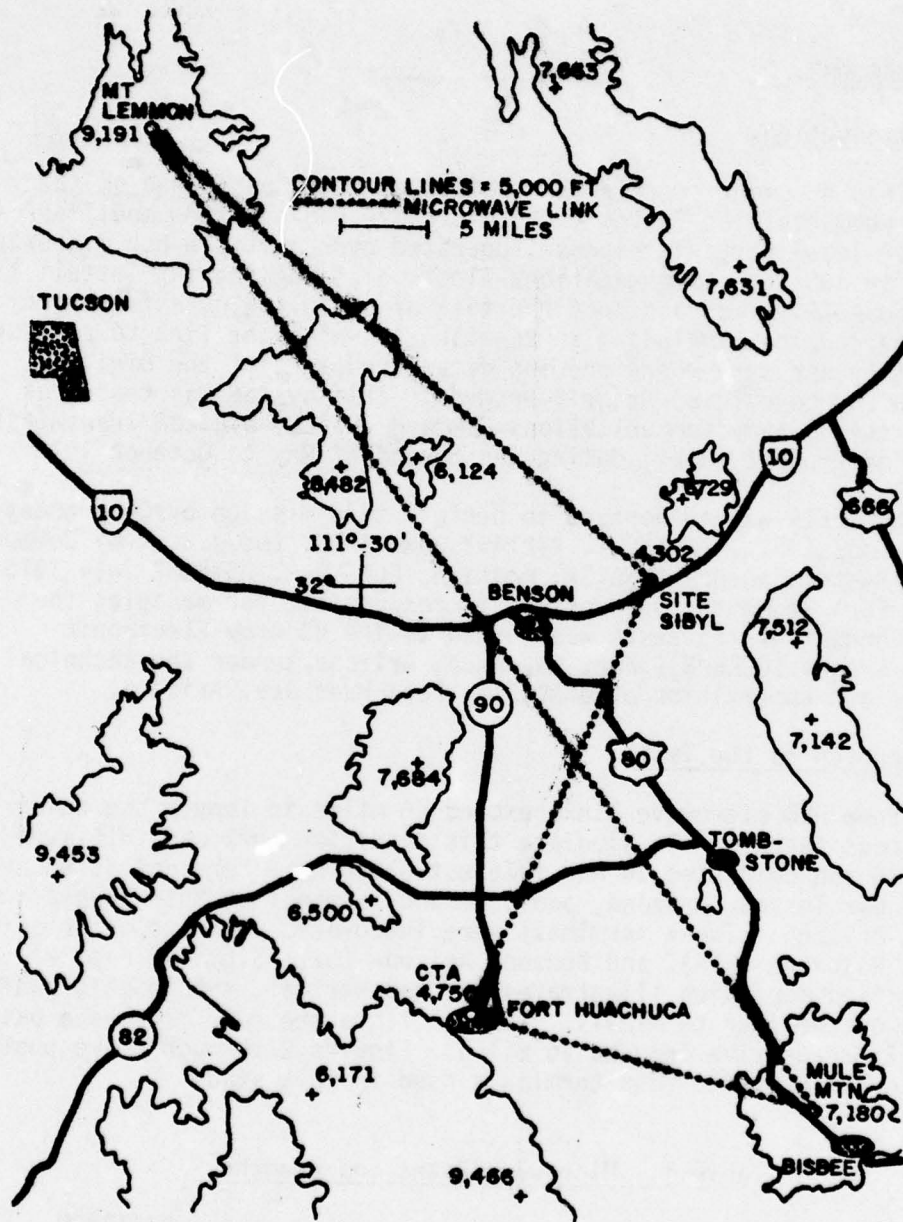

Figure 1. Simplified Map: 82-Mile Link

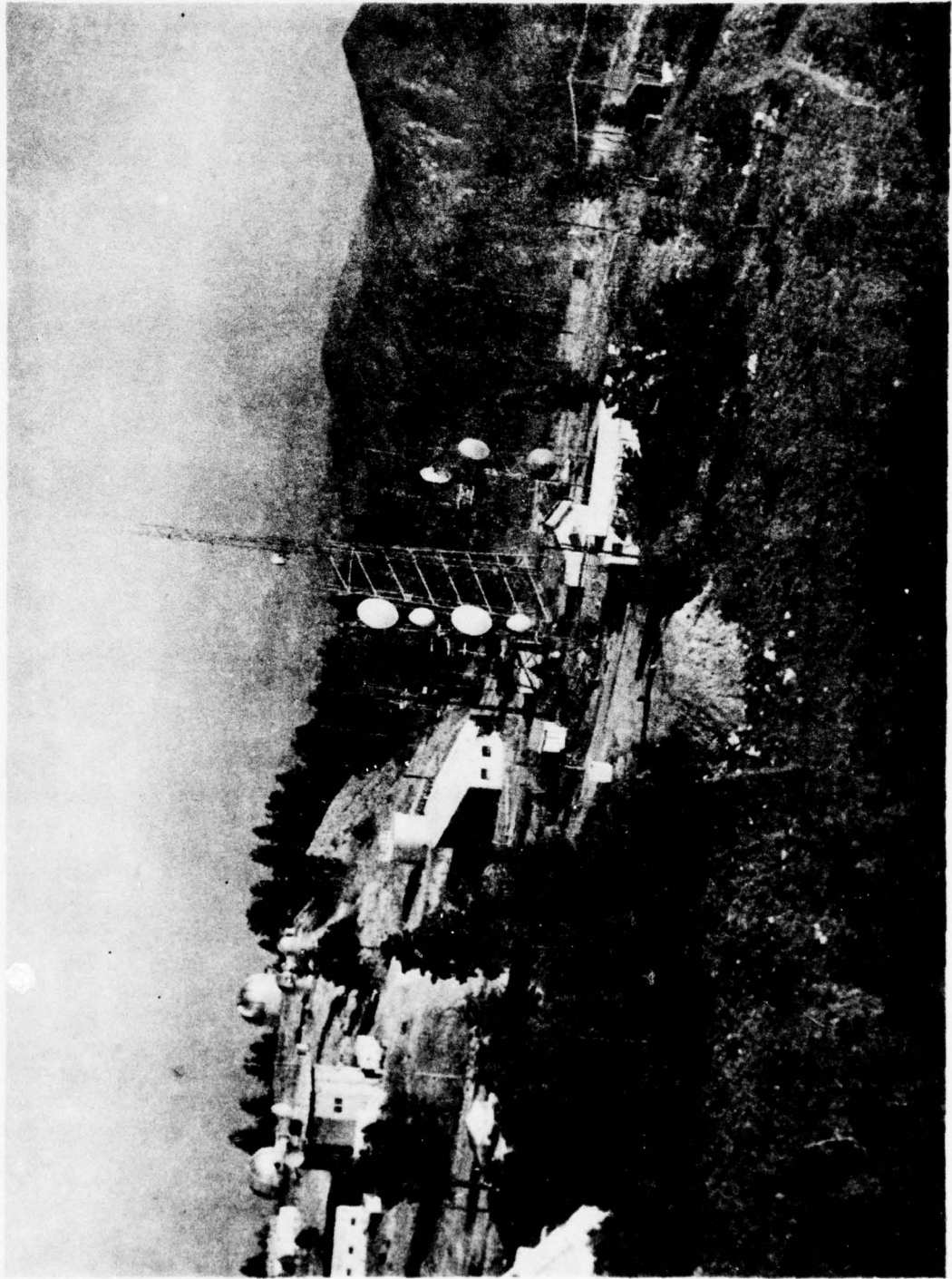

Figure 2. Photograph of Mount Lemmon Microwave Site

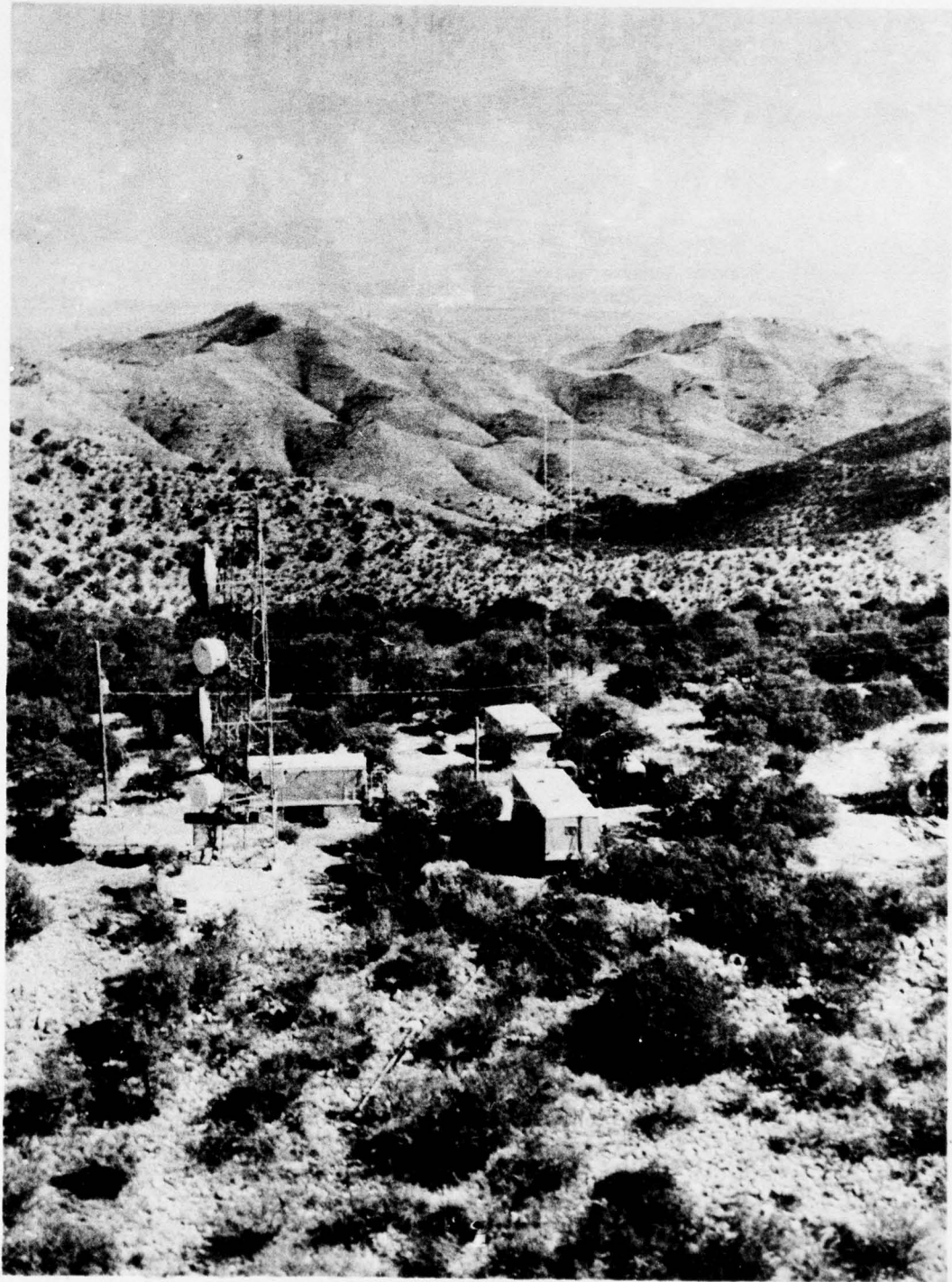

Figure 3. Photograph of Mule Mountain Microwave Site

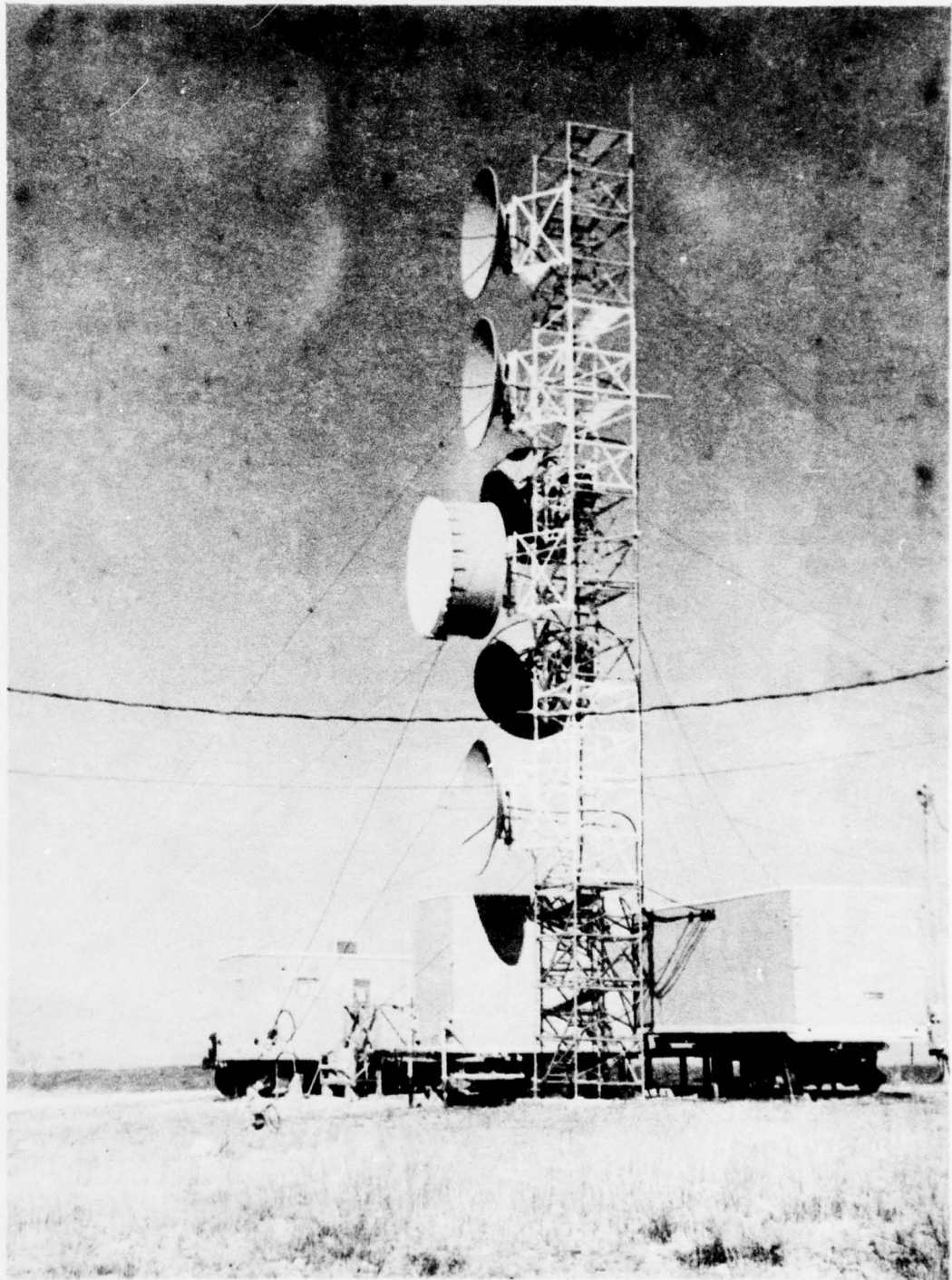

Figure 4. Photograph of Site Sibyl

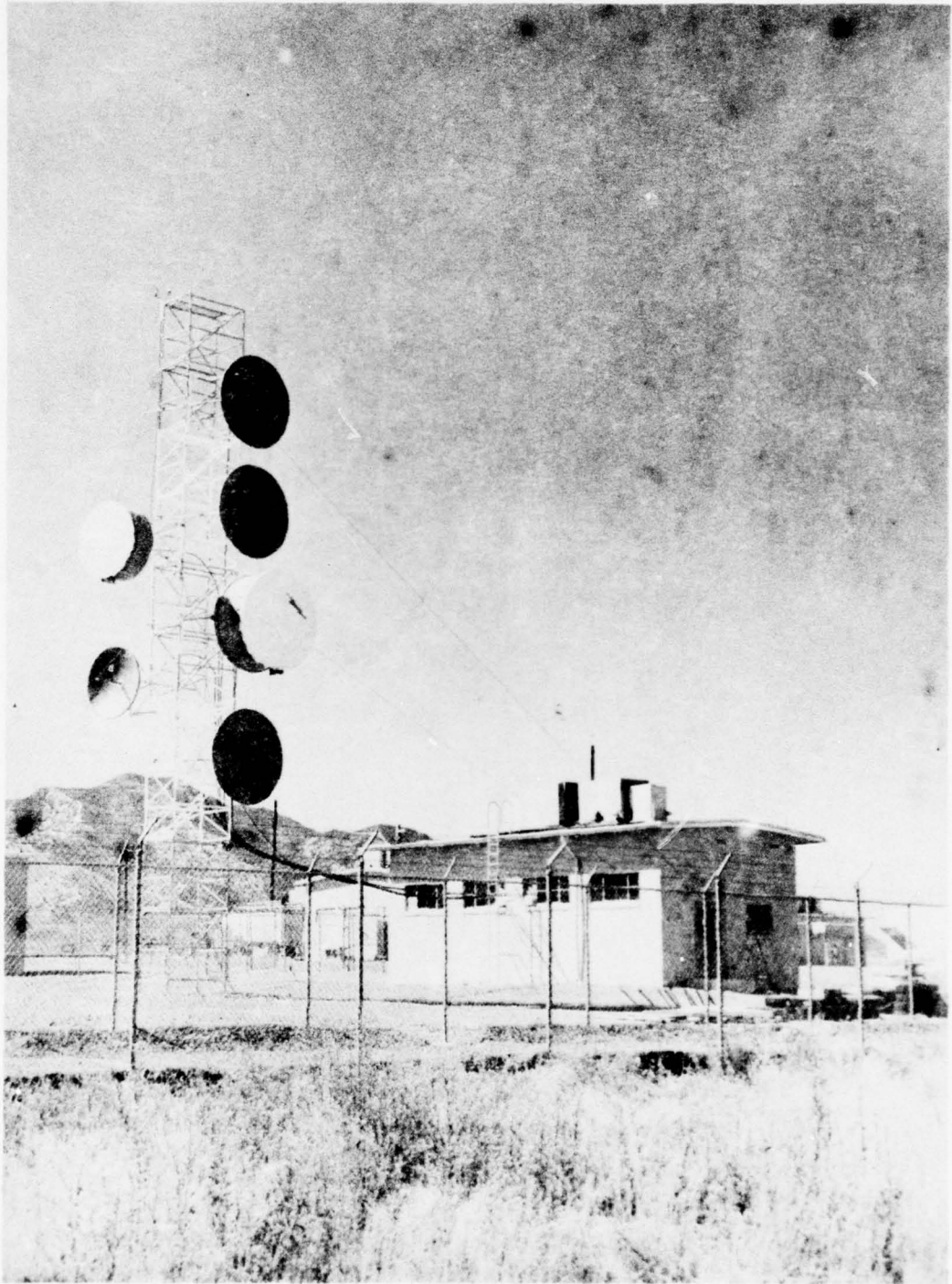

Figure 5. Photograph of CTA Microwave Site

1.2.2 To establish the priorities of engineering and testing, the areas of investigation were divided into four categories. Category I includes data collection and preliminary engineering analysis of received signal levels (RSL's), fade margins, fade depths, fade rates, fade durations, bit error rate (BER) vs RSL, multiplexer reframes, and baseband repeater operation. Category II includes data collection and engineering analysis of cross-polarization, space diversity receiver switching and 3-level logic violations, as well as final engineering analysis of long-term studies initiated in Category I. Category III is scheduled to encompass study of power spectrum, carrier-to-interference effects, correlation of short and long paths, and further tests of multiplexer performance. Evaluation of a degradation monitor and baseband impulse noise are addressed under Category IV. This document reports Category I activities, and a final report to be published in June 1977 will encompass Category II, III and IV findings.

1.3 General Test Objectives. The purpose of these tests performed on the CONUS link is to establish a data base and performance assessment of a similar microwave system in advance of the final implementation of DEB Stage 1. These tests measure the key parameters of partial response transmission over a microwave line-of-sight link. Comparison of actual measurements of RSL availability to mathematical predictions establish validity of those models, and confidence in the reliability of similar path predictions. Measurement of fade depths, rates, and durations forms a basis to calculate space diversity availability, expected BER availability, and correlation of error occurrence. BER vs RSL computations are the basic mode of system performance assessment. Baseband repeater performance indicates the feasibility of operating long links without the regeneration of data at each terminal. Multiplexer assessment identifies possible sources of error generation and can provide a valid indication of system quality before errors occur.

1.4 Summary of Findings. Fade margins as computed by instantaneous measurements of RSL's over the 82-mile link were not realized. While the mathematical model predicted no RSL's lower than -71 dBm, actual measurements resulted in 0.2% of all samples below this signal level. In general, above 99.0% availability a large discrepancy existed between the actual and predicted values of RSL. The number of fades recorded for one direction of transmission differed significantly from those recorded for the opposite direction of transmission. Correlation of fades over the long-link indicate the limited effectiveness of space diversity. A significant number of fade rates in excess of 70 dB/second were observed. More than 0.5% of the measured fade depths were 30 dB or greater. Fades in excess of 50 seconds duration at one receiver accounted for 19% of the recorded fades. Except for four dropouts, which must be considered, for over 23,515 minutes of testing, the average BER was computed to be 1.4×10^{-12} . After eight links of

repeaters without data regeneration a BER of 1.85×10^{-8} was measured, but the final terminal fade margin of 10 dB indicates a low availability for this performance. Multiplexer violations occurred when errors did not occur, and as violations increased, errors occurred, but without a precise correspondence. Certain waveguide connectors used in these tests were found to be unsatisfactory.

2. GENERAL.

2.1 Description of Equipment.

2.1.1 The primary equipment used in this test included ten T1-4000 multiplexers, six AN/FRC 162 radio systems, and two AN/FRC 165 radio systems.

2.1.2 The T1-4000 is a time division multiplexer (TDM) that accepts eight individual T1 lines, each at a nominal rate of 1.544 Mb/s. The multiplexer uses bit stuffing to cause all lines to attain a common rate, and low pass filters the resultant nonreturn to zero (NRZ) data stream to produce an analog partial response signal. Data is recovered in the receiver by passing the partial response waveform through amplitude slicers, and the resulting square waves from the high level and low level slicers are sent to an NRZ converter. The multiplexer uses a shift register scrambler to randomize the bit stream, which prevents the occurrence of energy concentration at discrete frequencies in the transmitted RF spectrum.

2.1.3 The AN/FRC 162 is a one-watt, frequency modulated radio system that operates in the 8 GHz band. The radio contains an on-line transmitter and receiver, a hot standby transmitter, and an errorless baseband switched diversity receiver. The baseband has been designed to accept an analog partial response signal with a bandwidth of 6.3 MHz. The service channel and supervisory channels are inserted in the baseband at 8.1 and 8.5 MHz. The output radio frequency (RF) spectrum is confined to a 14 MHz bandwidth by a 14 MHz bandpass filter and a modulation index of 0.5.

2.1.4 A traveling wave tube (TWT) final amplifier is added to the AN/FRC 162 to produce a 5 watt transmitter. In this configuration, the radio is identified as the AN/FRC 165.

2.2 Summary of AN/FRC 162 Test Results.

2.2.1 The AN/FRC 162 radio system is the heart of the DEB Stage 1 equipment and therefore of primary interest in this phase of the DTEP. For a thorough discussion of testing and engineering analysis, the reader should refer to Digital Transmission Evaluation Project, AN/FRC 162 Test, Final Report, CCC-CED-76-DTEP-011, published May 1976.

2.2.2 The BER vs RSL curve showed a performance variation among four radio combinations of 2.5 dB, which was somewhat dependent on alignment of the transmitter-receiver combination and differences in noise figure. The best combination yielded a curve displaced 3.5 dB from the referenced theoretical limits. These relationships are depicted in figure 6.

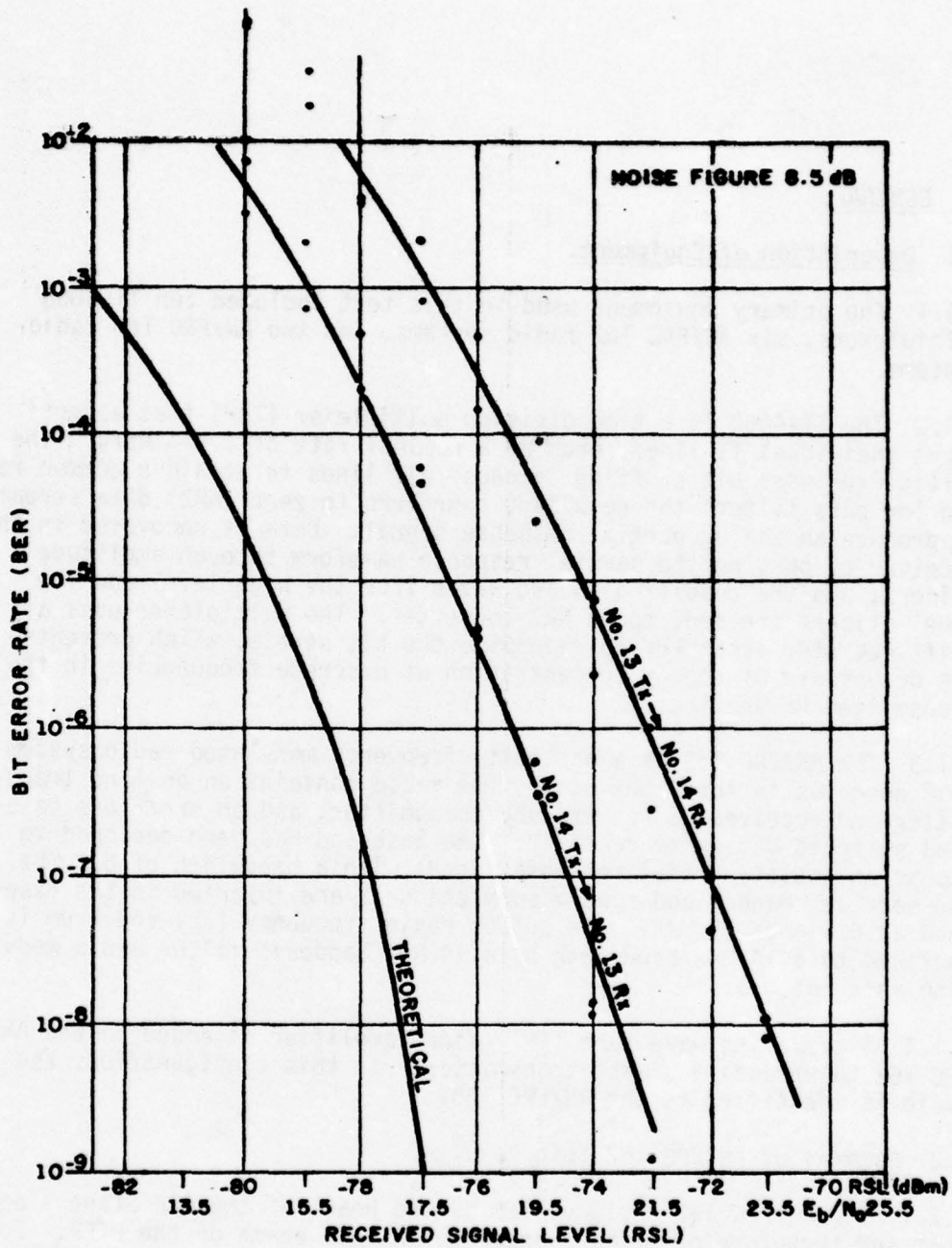

AN/FRC 162

Figure 6 Bit Error Rate vs Received Signal Level Characteristic Curves

Resistance to co-channel interference varied, with a 2 dB degradation apparent at a carrier-to-interference ratio (C/I) equal to 18 dB and 8 dB degradation apparent at a C/I equal to 12 dB. The worst interference effects under conditions of swept frequency interference occurred at 6.3 MHz from the carrier frequency. If FCC out-of-band limitations had been required, the spectrum would not have met the 14 MHz mask. The first shoulder would require up to 10 dB additional attenuation for compliance. The 99% power bandwidth was 12 MHz. The errorless receiver diversity switch operated error-free under normal conditions at high and low RSL's.

2.2.3 Availabilities of various BER's over the CTA to Site Sibyl microwave link are plotted in figure 7. This display indicates degradation due to the path and operational considerations not accounted for in back-to-back tests.

2.3 Test Methodology and Limitations.

2.3.1 The procedures in testing equipment and systems followed a published test plan adapted from standard practices as established in Technical Evaluation Line of Site and Troposcatter Links, DCS Quality Assurance Program, DCAC 310-70-57, Supplement 1, October 1974. Details of specific methodology are discussed under "Procedure" in each test section.

2.3.2 All RSL's recorded were referenced to the waveguide flange at the rack. All BER measurements used a pseudo-random pattern in excess of 1,000,000 bits (2^{20}) in length. All data collected was used in analysis except those portions obviously not representative of typical performance and clearly correlated to equipment or procedural failures.

2.3.3 No unusual limitations were encountered on this study. Limits on data were established by accuracy, stability, and resetability of the test equipment which were monitored constantly for correct operation and calibration. Calibration procedures followed Calibration Requirements for the Maintenance of Army Materiels, DA TB 43-180, December 1975.

2.4 Unscheduled Test Observations.

2.4.1 During the installation of equipment establishing the four terminals used in this project, the AN/FRC 162 radios were not equalized for baseband signal delay due to unavailability of delay equalization submodules. Preliminary tests and subsequent baseband repeater tests indicated that the radios performed satisfactorily. Additional information that delay equalization did not appreciably affect the three-level

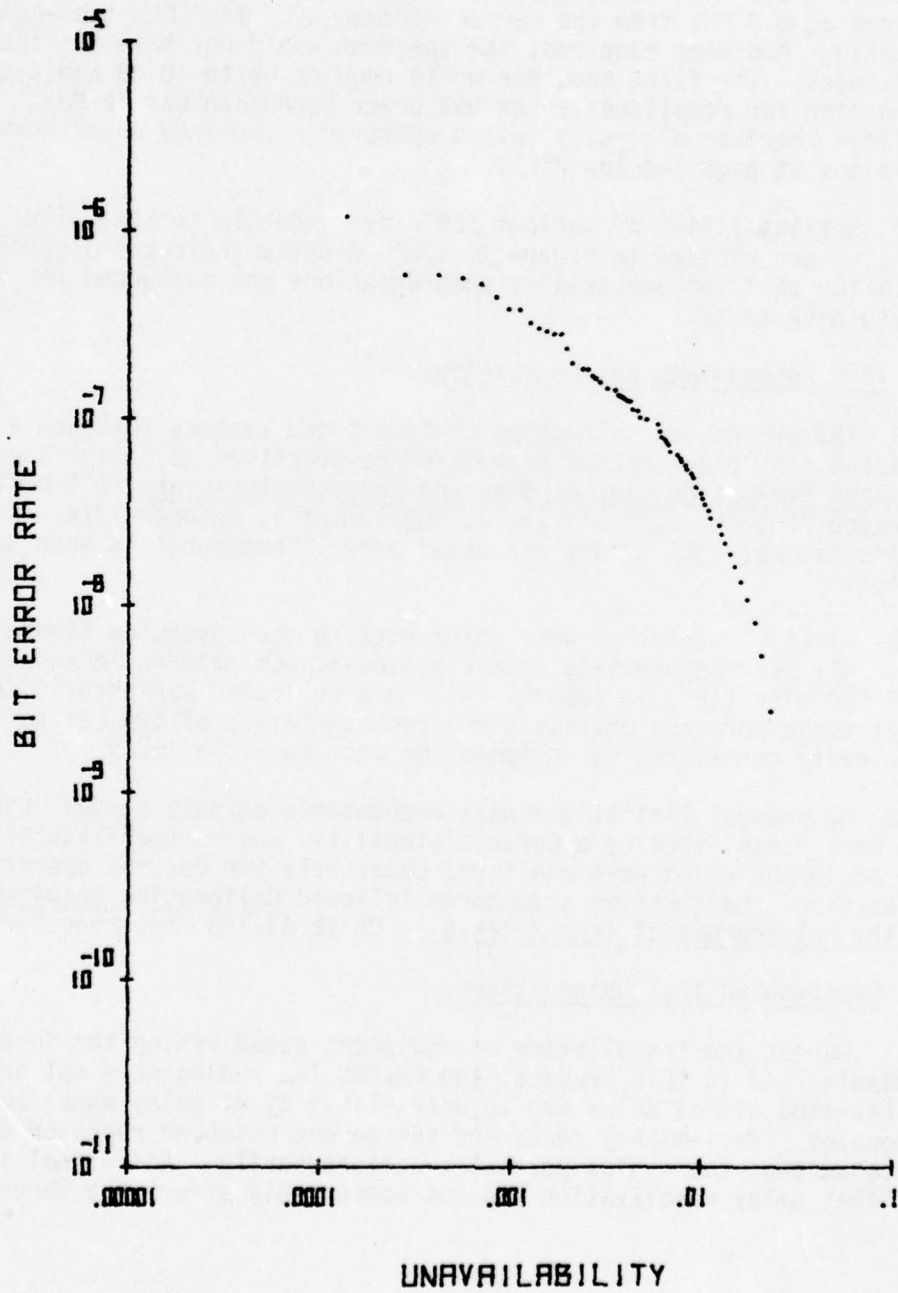

Figure 7. AN/FRC 162 Bit Error Rate vs Unavailability

partial response signal was reported in AFCS Technical Report, AN/FRC 162 Digital Radio Characterization, June 1976. Figure 8 shows a typical response technique operated in a constantly overloaded condition. In contrast to most FM systems, which are specified to have a noise power ratio (NPR) of 55 dB, this technique indicated a constant NPR of approximately 34 dB at the normal 2.2 dBm baseband input. This high level of intermodulation distortion inherent in the radio reduced to an insignificant proportion the effect of further distortion caused by unequal signal delay.

2.4.2 The Mount Lemmon-Mule Mountain link produced interference at the Site Sibyl receiver for the Mount Lemmon-Site Sibyl link. The Mount Lemmon site transmitted an 8.3655 GHz carrier to Site Sibyl, and an 8.3795 GHz carrier to Mule Mountain. The main beams were separated by approximately 16° , but radiation, probably from side lobes of the 5 watt output of the Mount Lemmon-Mule Mountain path were received at Site Sibyl approximately 20 dB below the other, desired signal. To attain a 1×10^{-6} BER performance level, the Site Sibyl receiver required a -56 dB RSL when the interfering signal was present, and only -72 dBm when this transmission was terminated. At the baseband level in the Site Sibyl receiver, the interferer was 10 dB below the peak power of the desired signal. A third measure of this interference effect yielded data which indicated a 15-20 dB degradation of the noise floor as measured at 6 MHz in a 3.1 kHz band.

2.4.3 Waveguide connectors manufactured by Prodelin were found to be deficient in matching rigid to semi-rigid waveguide. After tuning, this connector interface resulted in a 16-22 dB return loss over the frequency band of 15-20 MHz. Military Standard 188-313, Subsystem Design and Engineering Standards and Equipment Technical Design Standards for Long-Haul Communication Traversing Microwave LOS Radio and Tropospheric Scatter Radio; paragraph 5.11.2.2 states a requirement for a minimum return loss of 26 dB. Similar connectors made by Andrew Corporation interfaced waveguides with a resulting return loss of 30 dB over the same frequency range. The difference in performance may be explained by the difference in design. The Andrew Corporation device uses five tuning screws while Prodelin uses three. While Prodelin may manufacture a connector that is electrically equivalent to the Andrew device, the connector procured for these tests was not suitable.

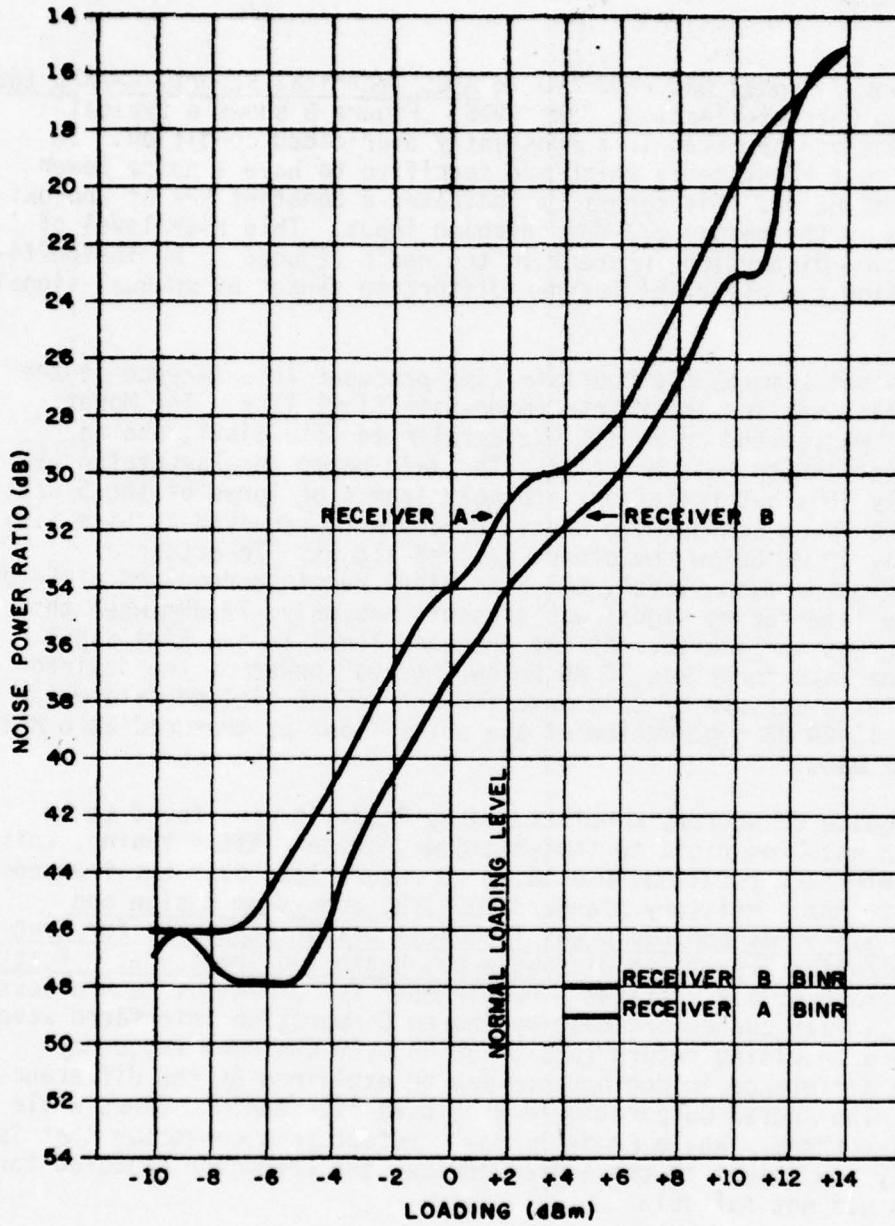

Figure 8. Typical Characteristics of Noise Power Ratio vs Input Loading

3. DETAILS OF TESTING.

3.1 Received Signal Levels: Predicted vs Actual.

3.1.1 Objective. The purpose of this test is to compare actual measurements of RSL availability to mathematical predictions. This comparison yields information concerning the reliability of the predictions of other similar microwave paths.

3.1.2 Procedure. A path profile was computed and plotted using techniques based on National Bureau of Standards Transmission Loss Predictions for Tropospheric Communication Circuits, Technical Note Number 101. Appendices A and B provide technical information and actual path profiles, respectively. Automatic gain control (AGC) voltages in the receiver under test were calibrated to actual RSL values, thereby permitting convenient monitoring of the RSL via the AGC variation. This calibration was performed daily. These voltages were recorded by continual strip chart recording, and at intervals by a digital printer as illustrated in figure 9. Instantaneous values were recorded at 1, 2, and 5-minute intervals. A total of 72,115 samples of RSL were recorded over a period of 88,673 minutes.

3.1.3 Results and Analysis.

3.1.3.1 Figure 10 shows the relationship between the predicted RSL availability and the actual availability. Actual data presented include RSL values recorded at 1-minute and 5-minute intervals and represents 71,495 samples taken over 87,433 minutes of continuous recording over the period of 15 July - 1 October. Data at 1-minute intervals give a higher degree of resolution to the period of testing but do not differ significantly from that data tabulated at 5-minute intervals.

3.1.3.2 It is evident from figure 10 that the model of RSL availability indicates better performance than that actually achieved. Up to approximately 99.0% availability, the recorded RSL's closely shadow the mathematical model, but for higher percentages of RSL availability, the discrepancy is quite large. The model predicts a 99.95% availability of -52 dBm or higher, while actual data show that an RSL of -80 dBm or higher was measured with that availability.

3.1.3.3 Instantaneous fade margins predicted for this microwave path were not attained. While the model predicted that RSL's lower than -71 dBm would not occur, in fact 0.20% of all time, the RSL was less than the -71 dBm level. There was general correlation between receivers for fading over the 82-mile link; and generally no correlation for fading between long and short links. The correlation over the long link indicates the limited effectiveness of space diversity.

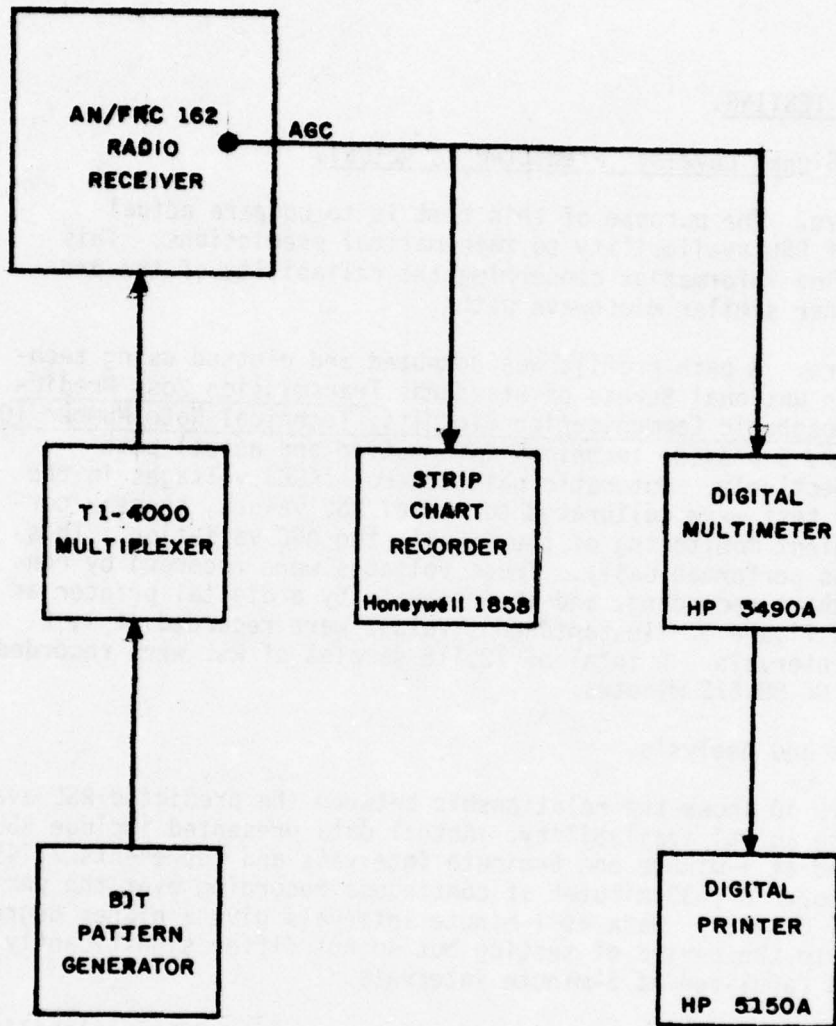

Figure 9. Test Configuration for Received Signal Level Measurement

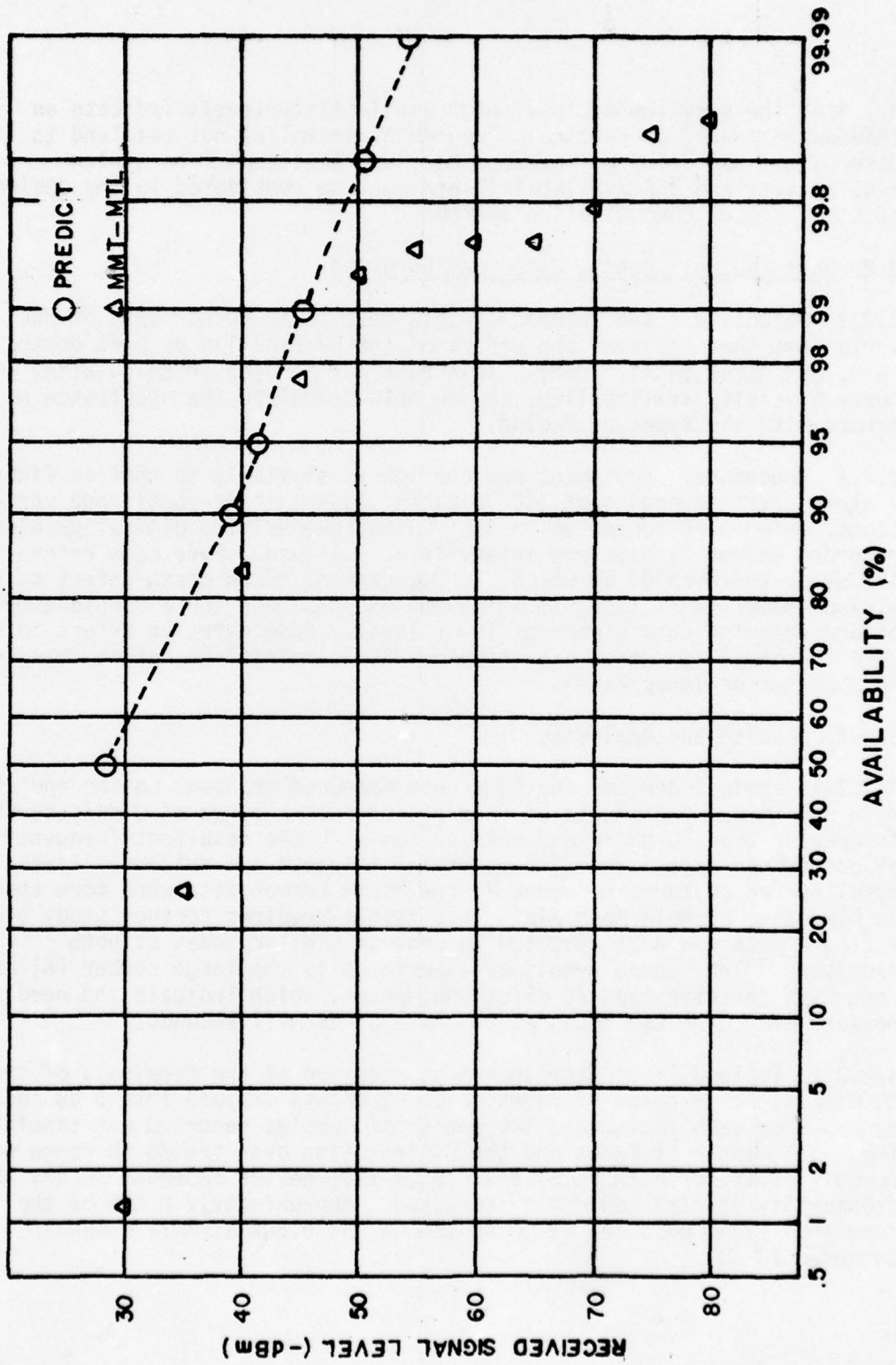

Figure 10. Predicted vs Actual Received Signal Level Relationship

3.1.3.4 The very low RSL's at high availability levels indicate an inadequate model, or particular equipment anomalies not resolved to date. This operating performance has important impact on system availability and BER availability and must be considered in the design of other signal communication systems.

3.2 Path Fading: Depth, Rate, and Duration.

3.2.1 Objective. The purpose of this test is to gather data of RSL variations that indicate the effect of the propagation path on depth, rate, and duration of fading. This data may be used in calculating space diversity availability, and to help correlate the occurrence of errors with the types of fading.

3.2.2 Procedure. Equipment was configured similarly to that in figure 9. A strip chart recording of AGC voltages measured time-continuous variations, which were converted to RSL. Simultaneously, a digital printer recorded values at discrete intervals of 1 minute. Fade rate refers to the slope (dB/second) at which the RSL varies. Fade depth refers to a minimum power level (dBm) to which the RSL descends for a single event before changing to a higher or lower level. Fade duration refers to the time (seconds) for which a particular RSL is maintained before changing to a higher or lower level.

3.2.3 Results and Analysis.

3.2.3.1 Table 2 depicts the fade rate measured at Mount Lemmon and at Mule Mountain. Increments of 5 dB/second over a range of 0 dB/seconds to greater than 70 dB/second were chosen with the resultant frequency of occurrence tabulated. Two points of interest are evident. First, the total number of fades recorded at the Mount Lemmon Site were more than double those at Mule Mountain. This result requires further study because a single path would be expected to produce similar fades at both receivers. The second result of importance is the large number (6) of very fast (greater than 70 dB/second) fades, which indicate the need to measure and correlate fades at the rate of dB/milliseconds.

3.2.3.2 Table 3 lists fade depths as recorded at the terminals of the 82-mile link. A range of fades up to 50 dB was divided into 5 dB increments. For each increment, the number of samples recorded was tabulated. The total number of fades and the distribution over the 50 dB range was roughly equal for both receivers. When fade depths exceeded 30 dB, the probability of elevated BER's increased. Approximately 0.66% of the tabulated fades recorded at Mount Lemmon and 0.50% at Mule Mountain exceeded 30 dB.

Table 2. Long Link Fade Rates

<u>FADE RATE (dB/sec)</u>	<u>NUMBER OF FADES AT RECEIVER</u>	
	<u>Mount Lemmon</u>	<u>Mule Mountain</u>
1 - 5	59	4
6 - 10	107	8
11 - 15	50	12
16 - 20	33	15
21 - 25	5	25
26 - 30	15	11
31 - 35	9	11
36 - 40	7	13
41 - 45	0	10
46 - 50	3	1
51 - 55	1	7
56 - 60	1	4
61 - 65	0	1
66 - 70	3	1
70+	<u>16</u>	<u>16</u>
TOTAL	309	139

Table 3. Long Link Fade Depths

<u>FADE DEPTH (dB)</u>	<u>NUMBER OF FADES AT RECEIVER</u>	
	<u>Mount Lemmon</u>	<u>Mule Mountain</u>
5 - 10	3172	3279
11 - 15	667	551
16 - 20	148	253
21 - 25	65	206
26 - 30	4	91
31 - 35	18	12
36 - 40	4	6
41 - 45	4	1
46 - 50	<u>1</u>	<u>3</u>
TOTAL	4083	4402

3.2.3.3 Duration of fades over the 82-mile link were sampled for 10-second increments over periods up to 3 minutes. Table 4 shows the frequency of occurrence at each terminal for the various durations. The referenced RSL from which a fade was measured was a nominal -33 dBm for 95% of all time. The total number of fades recorded at Mount Lemmon was more than twice that recorded at Mule Mountain. The distribution of durations showed that 95% of fades measured at Mount Lemmon were of duration 50 seconds or less, whereas 19% of those fades recorded at Mule Mountain were in excess of 50 seconds. The nonreciprocal fading on the same path remains unexplained at this time.

Table 4. Long Link Fade Durations

<u>FADE DURATION (sec)</u>	<u>NUMBER OF FADES AT RECEIVER</u>	
	<u>Mount Lemmon</u>	<u>Mule Mountain</u>
1 - 10	95	51
11 - 20	107	29
21 - 30	62	16
31 - 40	17	7
41 - 50	20	10
51 - 60 (1 min)	4	3
61 - 70	5	1
71 - 80	1	1
81 - 90	2	1
91 - 100	1	7
101 - 110	2	3
111 - 120 (2 min)	0	3
121 - 130	0	2
131 - 140	0	1
141 - 150	0	2
151 - 160	0	0
161 - 170	0	1
171 - 180 (3 min)	0	1
TOTAL	316	139

3.3 Bit Error Rate vs Received Signal Level.

3.3.1 Objective. The purpose of this test is to record the number of errors occurring over a period of time in order to compute a BER. Simultaneously, the RSL is measured to correlate BER with RSL's. This measure is the basic mode of system performance assessment.

3.3.2 Procedure. A bit pattern generator was connected to a T1 input of the T1-4000. A random bit pattern was connected to a second T1 input and looped six times in order to provide the final 12.5526 Mb/s input to the AN/FRC-162. Errors were counted on a bit error test set, while RSL's were monitored as previously depicted in figure 9.

3.3.3 Results and Analysis. Errors were counted for 21,705 samples of 65 seconds duration. Four times, each for a period of less than 15 seconds, the system lost synchronization causing an indeterminate number of errors. Except for these dropouts, only three errors were recorded. Therefore, excepting 4 dropouts, the long-term average BER was computed to be 1.4×10^{-12} . Table 5 shows the distribution of RSL's recorded over the period of time which included sample times for error measurements. Dropouts were caused by simultaneous deep fades causing RSL's below operational threshold for both receivers.

Table 5. Received Signal Level Distribution During Bit Error Rate Measurements

<u>RECEIVED SIGNAL LEVEL (dBm)</u>	<u>NUMBER OF SAMPLES</u>
-25	2
-25 to -30	204
-30 to -35	7910
-35 to -40	18380
-40 to -45	6027
-45 to -50	1040
-50 to -55	50
-55 to -60	4
-60 to -65	0
-65 to -70	0
-70 to -75	1
-75 to -80	0
-80	0

3.4 Baseband Repeater Operation.

3.4.1 Objective. The purpose of this test is to study the degradation of signal quality as the signal is relayed from one terminal to another without regeneration of the data by multiplexers. Baseband frequency response, BER, and percent error free samples are reported to indicate this degradation.

3.4.2 Procedure. Figure 11 depicts the test configuration for baseband repeater operation. The test signal was repeated up to a maximum eight links, employing seven baseband repeaters. Figure 12 depicts the two route configurations used to attain this maximum.

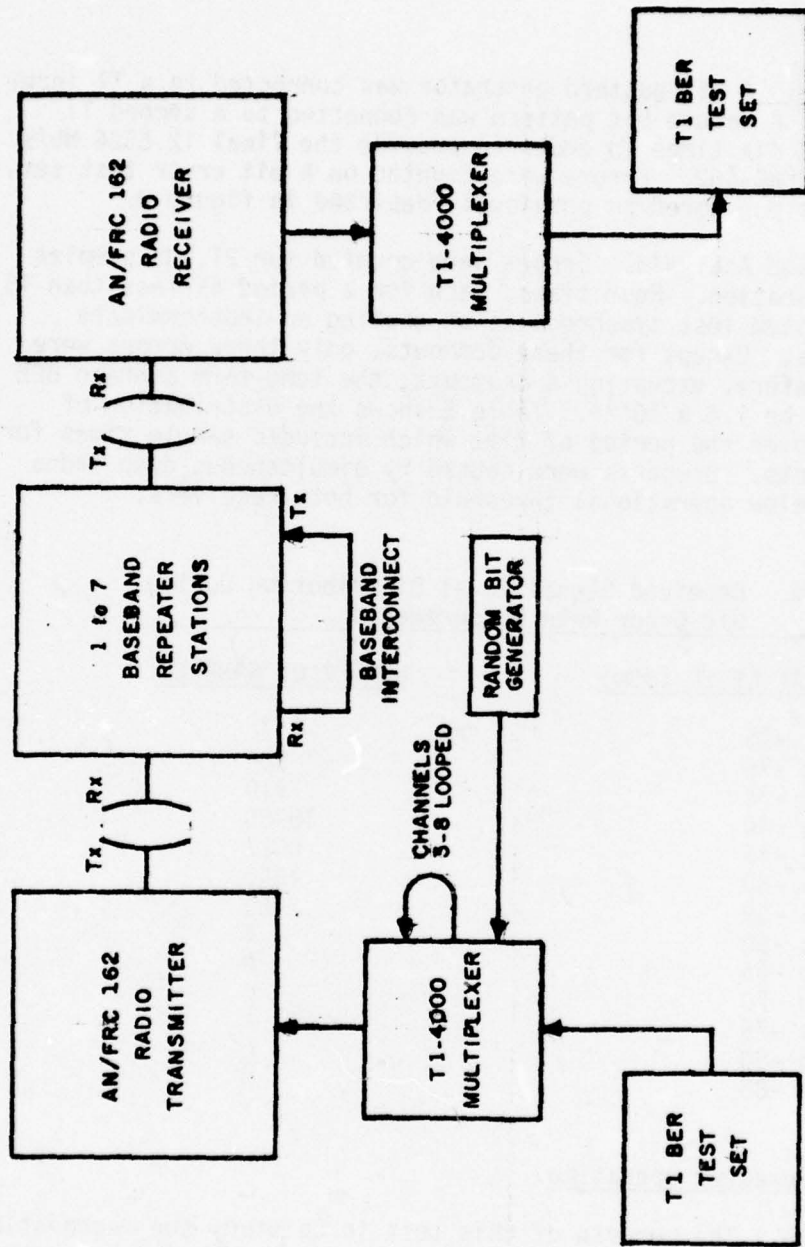

Figure 11. Test Configuration for Baseband Repeater Operation

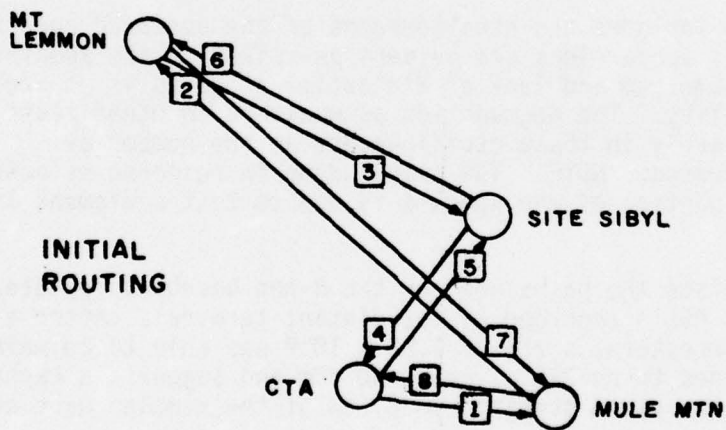
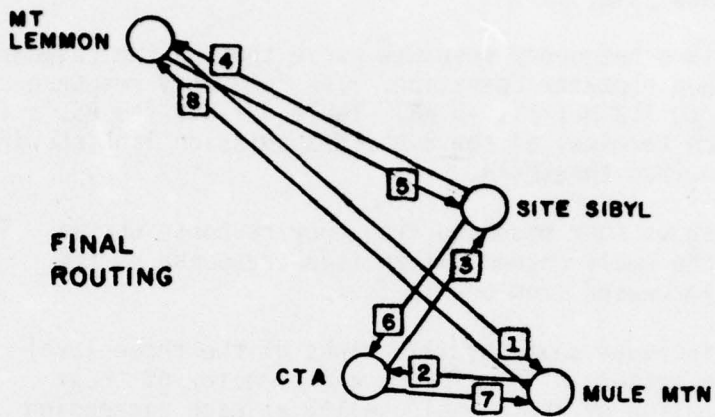

Figure 12. Eight-Hop Transmission Diagrams

3.4.3 Results and Analysis.

3.4.3.1 Figure 13 is a frequency response curve showing the baseband response for the 8-hop repeater operation. The frequency response can be stated as 370 Hz to 7.2 MHz ± 1 , -3 dB. Table 6 lists the RSL's for a BER of 10^{-6} at each terminal of the 8-hop transmission link showing the elevation of required threshold.

3.4.3.2 Figure 14 shows four baseband frequency response curves. The illustration shows the small change in amplitude response as the number of hops was increased from one to four.

3.4.3.3 Figure 15 includes seven oscillographs of the three-level partial response eye pattern. The clarity and symmetry of these patterns is an indication of the signal quality at each succeeding repeater terminal. Degradation can be seen to accumulate and appear especially poor at Site Sibyl (4th terminal) where interference from another transmitter located at Mount Lemmon was a factor.

3.4.3.4 Figure 16 includes ten oscillographs of the baseband spectra. The 8.1 and 8.5 MHz subcarriers are evident as spikes in the spectrum. The shape of the spectrum and lack of distortion products is an indication of signal quality. The degradation as measured in other tests does not appear clearly in these oscillographs as the number of repeaters was increased. NOTE: The slight drop in response evident at the low frequency portion of the spectra is due to test equipment limitations.

3.4.3.5 Table 6 lists the paths used on the 8-hop baseband repeater with the resultant RSL's recorded at the distant terminal. After eight hops of baseband repeaters, a BER of 1.85×10^{-8} was able to be maintained. This BER corresponded to an RSL of only -40 dBm and suggests a rather low availability. At the ninth terminal 98.8166% of the samples were errorless.

Table 6. Baseband Repeater Performance

<u>PATH</u>	<u>RECEIVED SIGNAL LEVEL (dBm) TO GIVE 1×10^{-6} BER</u>
Mount Lemmon to Mule Mountain	-70.0
Mule Mountain to CTA	-67.0
CTA to Site Sibyl	-60.0
Site Sibyl to Mount Lemmon	-60.0
Mount Lemmon to Site Sibyl	-54.0
Site Sybil to CTA	-68.0
CTA to Mule Mountain	Not measured
Mule Mountain to Mount Lemmon	-40.0

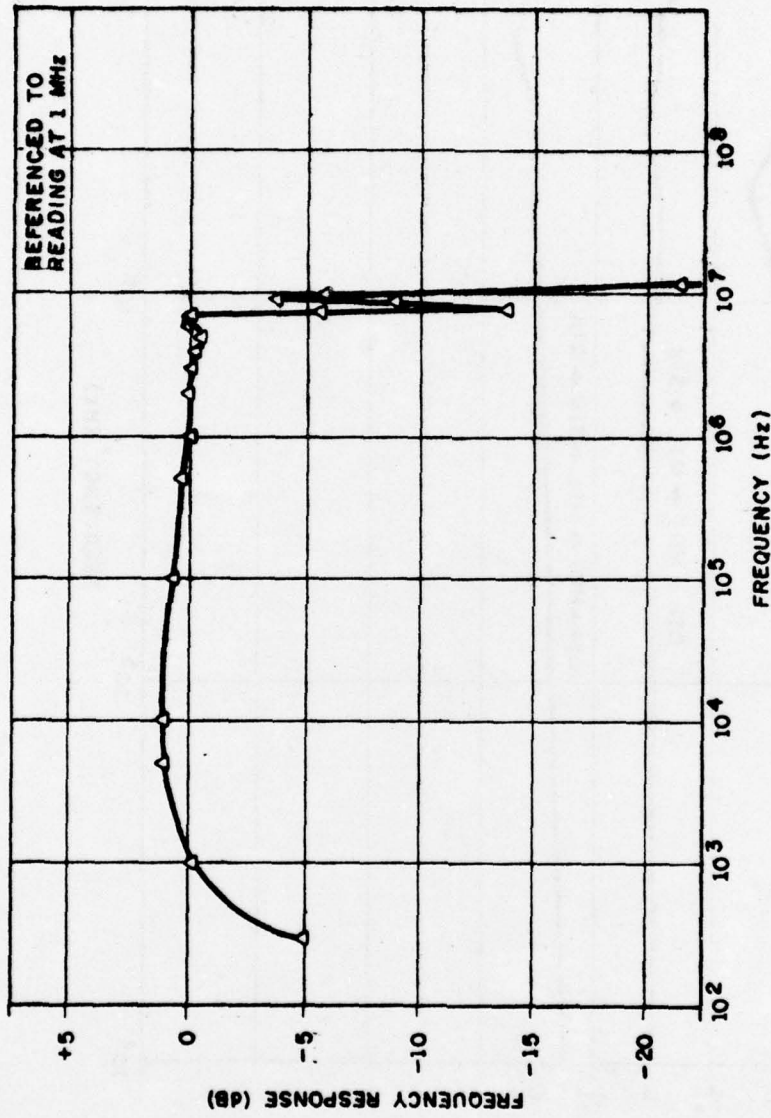

Figure 13. Baseband Frequency Response Characteristics for 8-Hop Transmission

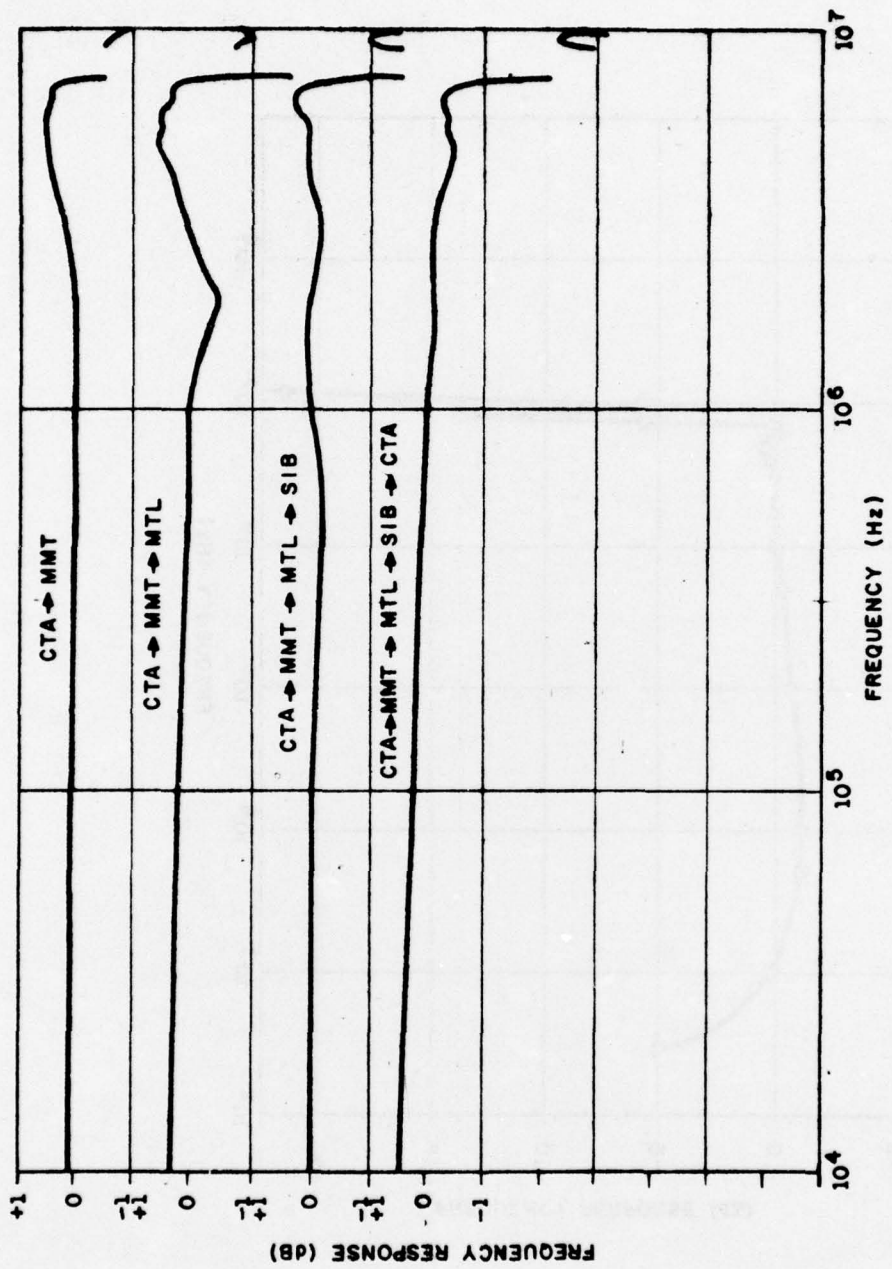
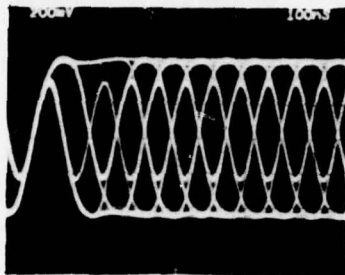
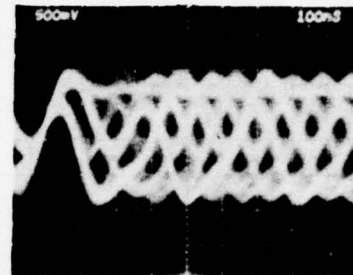

Figure 14. Baseband Frequency Response Characteristics for 1,2,3, and 4-Hop Transmissions



Reference



6th Terminal

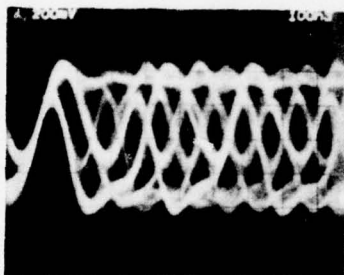

3rd Terminal

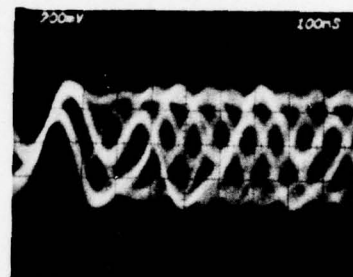

7th Terminal

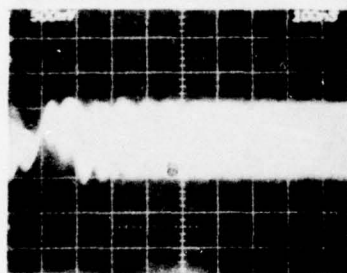

4th Terminal



8th Terminal

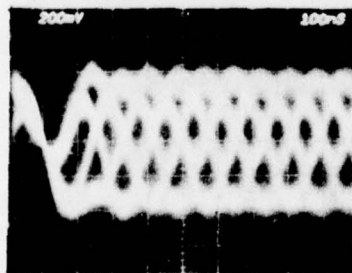

5th Terminal

Figure 15. Oscillographs of Eye Patterns for Baseband Repeater Operation

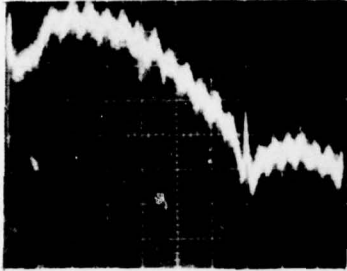

Multiplexer Output
Reference

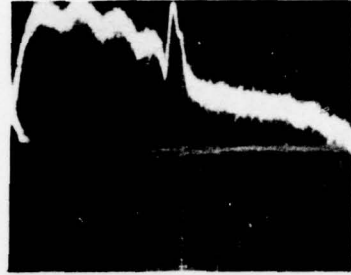

3rd Terminal

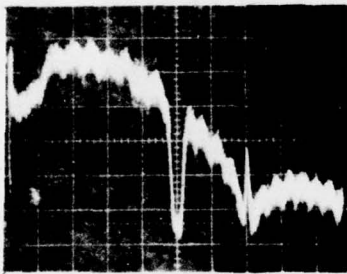

Radio Output
Reference

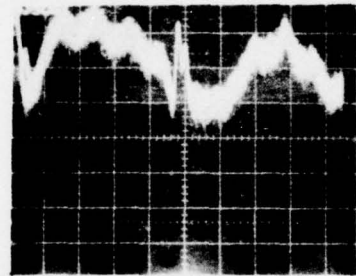

4th Terminal

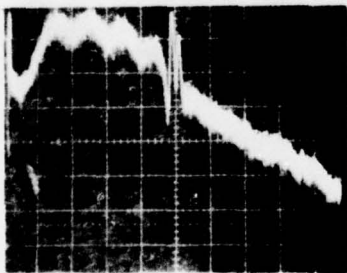

2nd Terminal

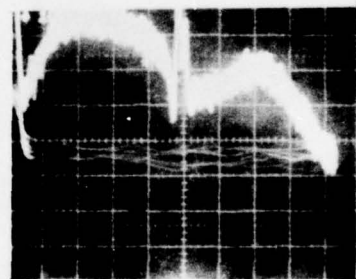

5th Terminal

Figure 16. Part I-Oscillographs of Sequential Baseband Spectra
(Repeater Operation)



6th Terminal

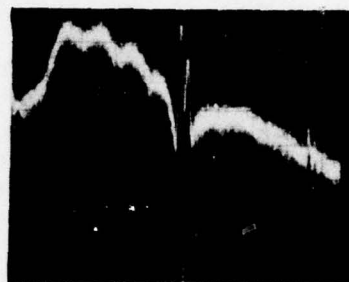

8th Terminal

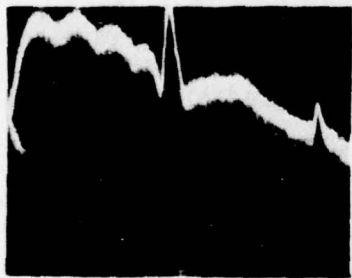

7th Terminal

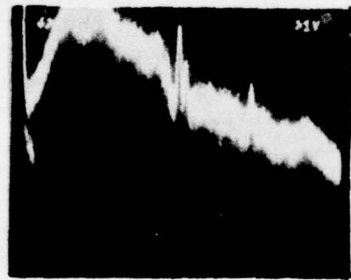

9th Terminal

Figure 16. Part II-Oscillographs of Sequential Baseband Spectra
(Repeater Operation)

3.4.3.6 Results from this test confirmed that any combination of radios and multiplexers will support a BER of 5×10^{-9} or better after four relays of baseband repeaters. Although a gradual degradation of signal quality occurred as the number of repeaters was increased, the greatest variability of BER performance was caused by differing multiplexer sensitivities. Because of these differences in sensitivity, errors were recorded at one site when errors were not recorded at another subsequent site. In these instances, the second multiplex was better able to demultiplex the slightly degraded signal.

3.4.3.7 Results indicated that the system performance may be improved by using signal conditioning between the radio baseband output and the multiplexer input in order to remove out of band noise and the two subcarrier signals. Baseband repeaters created a system filter between two terminals. That is, at the repeater site the multiplexer used to monitor the baseband signal received perturbations caused by out of band noise, which was effectively removed by the band limiting characteristics of the transmitter. In this way the end terminal was not affected by the total out of band noise generated between the initial terminal and the intermediate repeater.

3.5 Multiplexer Performance.

3.5.1 Objective. The objective of this test is to record the number of major and minor multiplexer reframes. A major reframe indicates resynchronization of the entire data stream at the 12.5526 Mb/s level, and a minor reframe indicates resynchronization of a T1 data stream within the total data stream. Reframes give indications of lowered signal quality and are an indication of performance degradation.

3.5.2 Procedure. A chart recorder (Honeywell 1858) was connected to the appropriate test points of the second-level multiplexer to record three-level partial response violations. Simultaneously, RSL's were recorded as described in section 3.1.2. Data for two multiplexers were gathered as the RSL was varied by introducing attenuation in the transmitter waveguide.

3.5.3 Results and Analysis.

3.5.3.1 Violations did occur when errors did not occur. When errors and violation occurred simultaneously, there was no constant ratio between the numbers of violations and the number of errors. However, as the numbers increased in magnitude the ratio of violations to errors diminished. In addition to errors causing reframes, these reframes created additional errors.

3.5.3.2 For multiplexer A, no major reframes occurred with an RSL of -81 dBm, or higher. This RSL corresponded to a BER of 1×10^{-3} , and 172,000 violations/second. Similarly, no minor reframes occurred with an RSL of -75 dBm or higher. This RSL corresponded to a BER of 3×10^{-5} and 1812 violations/second. The maximum number of violations that occurred without an error was 214.

3.5.3.3 For multiplexer B, no major reframes occurred with an RSL of -78 dBm or higher. This RSL corresponded to a BER of 5×10^{-2} , and 240,000 violations/second. Similarly, no minor reframes occurred with an RSL of -74 dBm or higher. This RSL correlated with a BER of 4×10^{-4} , and 12,000 violations/second. The maximum number of violations that occurred without an error was 860.

APPENDIX A

Table 7 Terminal Equipment Specifications

SITE ABBREVIATION	LINK TO	TYPE EQUIPMENT	FREQUENCY (GHz)	TRANS/RECEIVER	POWER (Watts)	TOWER HEIGHT (Ft) -	ANTENNA HEIGHTS (Ft)	ANTENNA DIAMETER (Ft)	PATH LENGTH (Miles)	PREDICTED RECEIVE SIGNAL LEVEL (dbm)
CTA	SIB	AN/FRC-162	8.398/8.2975	1	60-39/19	8	32.1	-35		
	MMT	AN/FRC-162	8.275/8.11	1	60-44/24	6	23.7	-41		
SIB	CTA	AN/FRC-162	8.2975/8.398	1	60-39/19	8	32.1	-35		
	MTL	AN/FRC-162	8.2045/8.3655	1	60-44/24	8	47.3	-40.7		
MMT	CTA	AN/FRC-162	8.11/8.275	1	60-35/10	6	23.7	-41		
	MTL	AN/FRC-165	8.2185/8.3795	5	60-46/20	12	82	-32		
MTL	MMT	AN/FRC-165	8.3795/8.2185	5	80-66/36	12	82	-32		
	SIB	AN/FRC-162	8.3655/8.2045	1	80-51/21	8	47.3	-40.7		

APPENDIX B

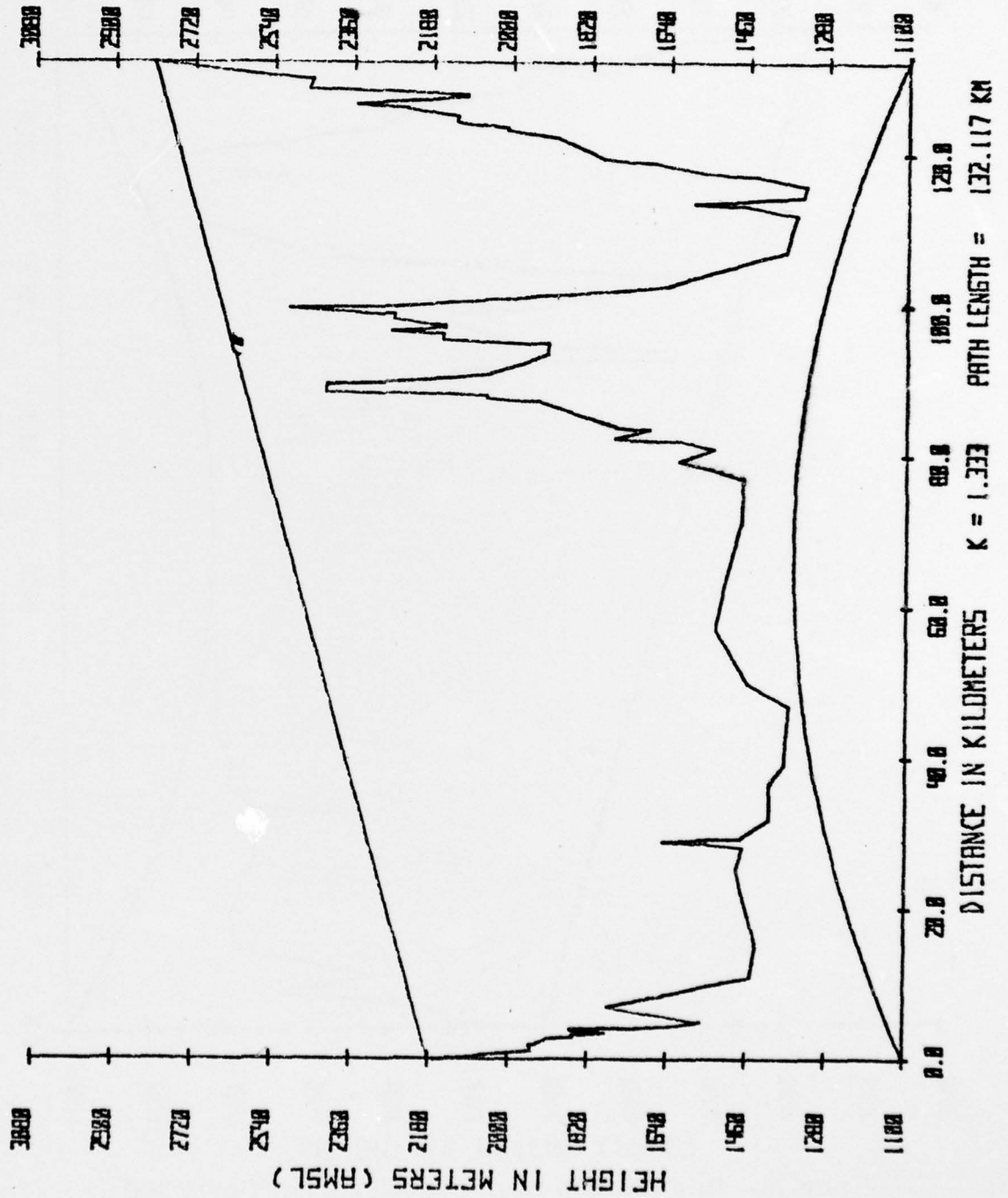

Figure 17. Mule Mountain-Mount Lemmon Path Profile ($K=4/3$)

APPENDIX B

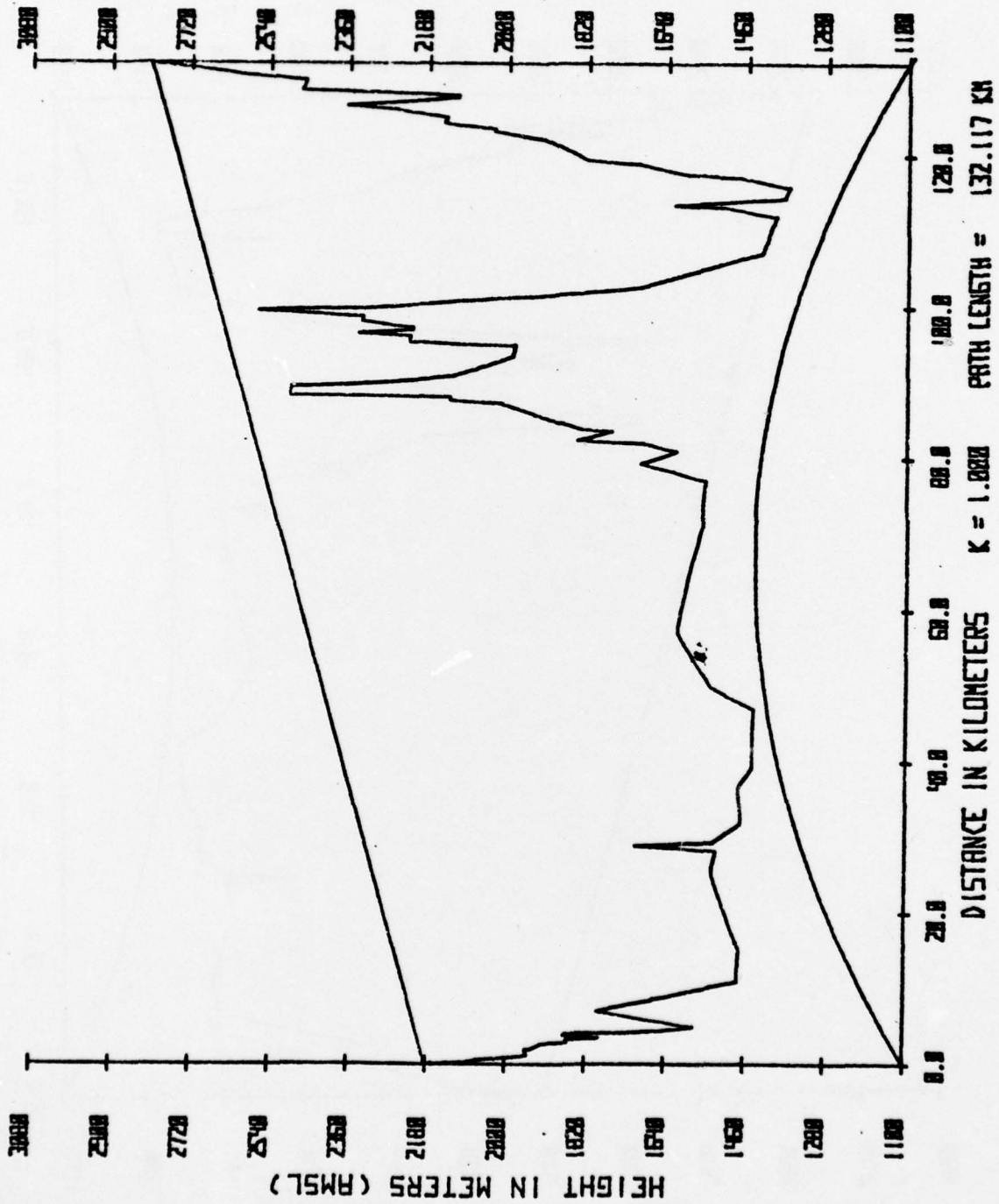

Figure 18. Mule Mountain-Mount Lemmon Path Profile (K=3/3)

APPENDIX B

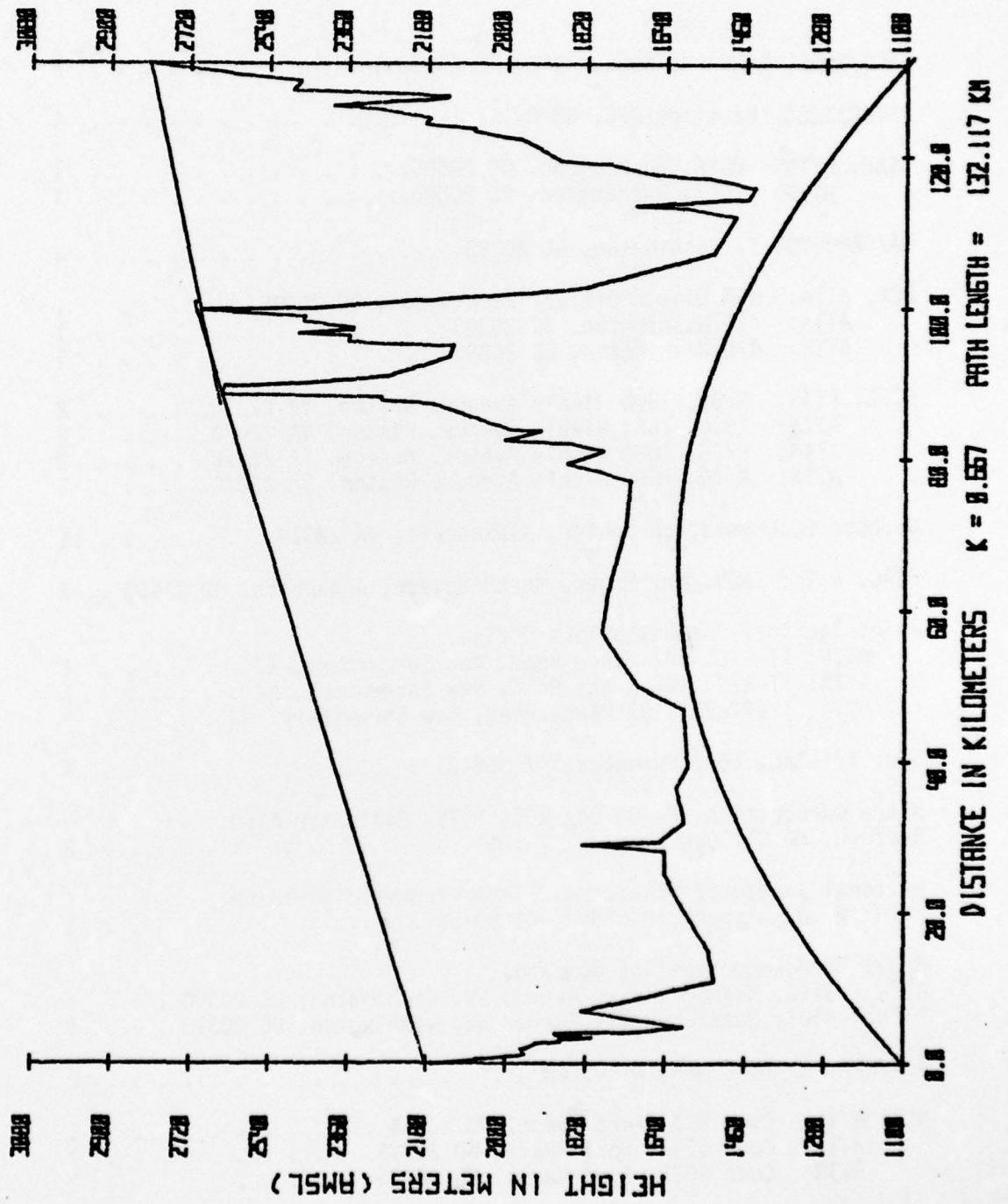

Figure 19. Mule Mountain-Mount Lemmon Path Profile (K-2/3)

DISTRIBUTION

COPIES

AFCS/EPES, Richards Gebaur AFB, MO 64030 2

AFTEC/TEEC, Kirtland AFB, NM 87115 1

CSAF, ATTN: RDPE, Washington, DC 20305. 1
 ATTN: PRCX, Washington, DC 20305. 1

DA/DAMO-TCS-T, Washington, DC 20305. 4

DCA, ATTN: NSA Liason Office, Washington, DC 20305. 1
 ATTN: 430, Washington, DC 20305 1
 ATTN: 470, Washington, DC 20305 1

DCEC, ATTN: R105, 1860 Wiehle Avenue, Reston, VA 22070. 2
 ATTN: R220, 1860 Wiehle Avenue, Reston, VA 22070. 2
 ATTN: R230, 1860 Wiehle Avenue, Reston, VA 22070. 2
 ATTN: R710, 1860 Wiehle Avenue, Reston, VA 22070. 2

Defense Documentation Center, Alexandria, VA 22314 15

ECAC, ATTN: ACV, Mr. Mager, North Severn, Annapolis, MD 21402 . 3

Joint Tactical Communications Office,
 ATTN: TT-E-E, 197 Hance Road, New Shrewsbury, NJ 1
 ATTN: TT-E-S, 197 Hance Road, New Shrewsbury, NJ 1
 ATTN: TT-RT-TA, 197 Hance Road, New Shrewsbury, NJ 1

JTO, Tri-Tac, Fort Huachuca, AZ 85613. 1

Mitre Corporation, P. O. Box 208, ATTN: Mail Stop A160,
 Bedford, MA 01730. 2

National Bureau of Standards, Electromagnetic Division,
 ATTN: W. J. Alspach, Boulder, CO 80302 1

Naval Telecommunications Command,
 ATTN: 3426, Massachusetts Avenue NW, Washington, DC 20390 . . . 1
 ATTN: 4401, Massachusetts Avenue NW, Washington, DC 20390 . . . 1

NCA/EPE, Griffis AFB, NY 13440 2

NSA, ATTN: Code R15, Fort Meade, MD 20755 1
 ATTN: Code S254, Fort Meade, MD 20755. 1
 ATTN: Code 4023, Fort Meade, MD 20755. 2

COPIES

RADC, ATTN: DCLD, Griffis AFB, NY 13440	2
ATTN: DCC, Griffis AFB, NY 13440.	1
USACC, ATTN: CC-FD-MMR, Fort Huachuca, AZ 85613	4
ATTN: CC-POA-SM, Fort Huachuca, AZ 85613	2
USACEEIA, ATTN: CCC-CED, Fort Huachuca, AZ 85613.	10
ATTN: CCC-TCD, Fort Huachuca, AZ 85613.	2
ATTN: CCC-TED, Fort Huachuca, AZ 85613.	5
USACSA, ATTN: CCM-EU-ED, Fort Monmouth, NJ 07703	2
ATTN: CCM-TD, Fort Monmouth, NJ 07703.	2
ATTN: CCM-SP, Fort Monmouth, NJ 07703.	1
ATTN: CCM-SG, Fort Huachuca, AZ 85613.	1
ATTN: CCM-RD, Fort Monmouth, NJ 07703.	1
US Department of Commerce, Office of Telecommunications, Institute for Telecommunications Sciences, ATTN: Richard Skerjanec, Boulder, CO 80302.	2
USAECOM, ATTN: AMSEL-NL-P3, Fort Monmouth NJ 07703.	1
ATTN: AMSEL-NL-D, Fort Monmouth, NJ 07703.	1
USAEPG/STEEP-MT-GR, Fort Huachuca, AZ 85613.	4

