

AD-A032 810

COMSTOCK AND WESTCOTT INC CAMBRIDGE MASS
DOUBLE-DECK SOLAR EXTREME ULTRAVIOLET SPECTROMETERS.(U)
JUL 76 J F MCGRATH, J P PADUR

F/G 14/2

F19628-73-C-0253

UNCLASSIFIED

AFGL-TR-76-0160

NL

1 of 2
ADA032810

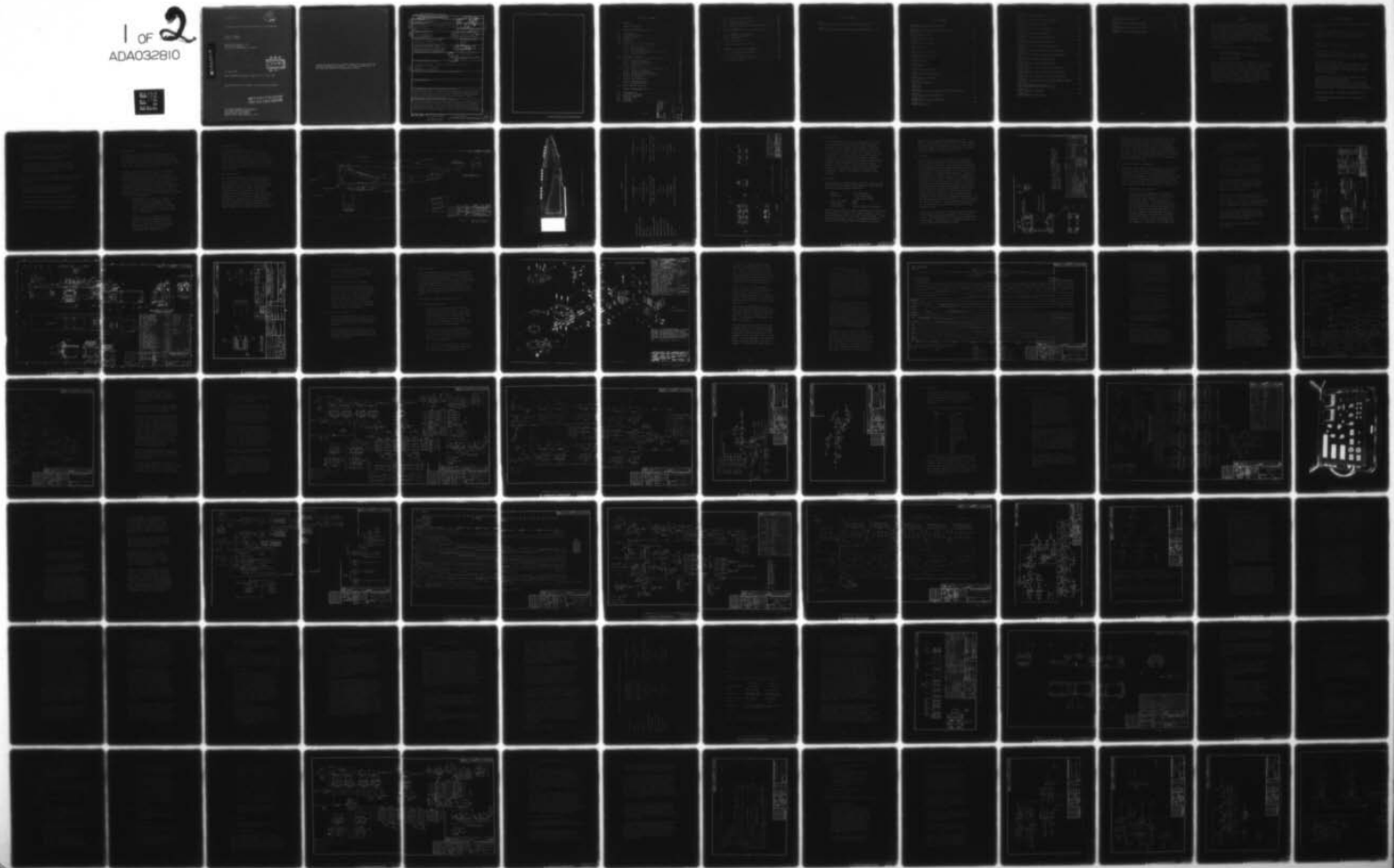

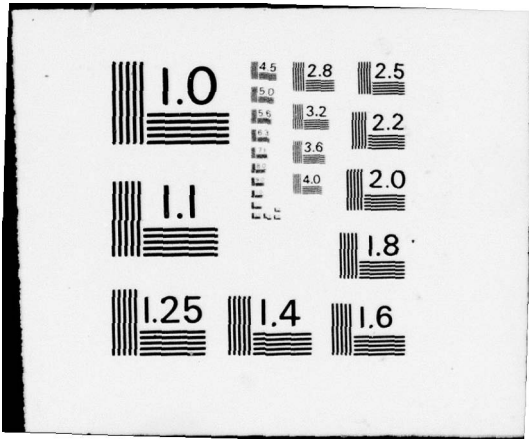

AFGL-TR-76-0160

12
NW

DOUBLE-DECK SOLAR EXTREME ULTRAVIOLET SPECTROMETER

John F. McGrath
Joseph P. Padur

Comstock & Wescott, Inc.
765 Concord Avenue
Cambridge, Massachusetts 02138

AD A 032810

DD
REC
DEC 3
R
LL
A

31 July 1976

Final Report for Period 1 May 1973 - 30 June 1976

Approved for public release; distribution unlimited

COPY AVAILABLE TO DDC DO
PERMIT FULLY LEGIBLE PROC

AIR FORCE GEOPHYSICS LABORATORY
AIR FORCE SYSTEMS COMMAND
UNITED STATES AIR FORCE
HANSCOM AFB, MASSACHUSETTS 01731

Qualified requestors may obtain additional copies from the Defense Documentation Center. All others should apply to the National Technical Information Service.

UNCLASSIFIED

SECURITY CLASSIFICATION OF THIS PAGE (When Data Entered)

19 REPORT DOCUMENTATION PAGE		READ INSTRUCTIONS BEFORE COMPLETING FORM	
1. REPORT NUMBER AFGL TR-76-0160 ✓	2. GOVT ACCESSION NO.	3. RECIPIENT'S CATALOG NUMBER 9	rept.
4. TITLE (and Subtitle) DOUBLE-DECK SOLAR EXTREME ULTRAVIOLET SPECTROMETERS.		5. TYPE OF REPORT & PERIOD COVERED Final 1 May 1973 - 30 June 1976 ✓	
7. AUTHOR(S) John F. McGrath Joseph P. Padur	15	6. PERFORMING ORG. REPORT NUMBER	
9. PERFORMING ORGANIZATION NAME AND ADDRESS Comstock & Wescott, Inc. ✓ 765 Concord Avenue Cambridge, Massachusetts 02138		8. CONTRACT OR GRANT NUMBER(S) F19628-73-C-0253 new	
11. CONTROLLING OFFICE NAME AND ADDRESS Air Force Geophysics Laboratory Hanscom AFB, Massachusetts 01731 Monitor/Charles W. Chagnon/LKO	11	10. PROGRAM ELEMENT, PROJECT, TASK AREA & WORK UNIT NUMBERS 66880601 62101F 686688	
14. MONITORING AGENCY NAME & ADDRESS (if different from Controlling Office)	12	12. REPORT DATE 31 July 1976	
	149 p.	13. NUMBER OF PAGES 98	
16. DISTRIBUTION STATEMENT (of this Report) Approved for public release; distribution unlimited		15. SECURITY CLASS. (of this report) Unclassified	
17. DISTRIBUTION STATEMENT (of the abstract entered in Block 20, if different from Report)		15a. DECLASSIFICATION DOWNGRADING SCHEDULE	
18. SUPPLEMENTARY NOTES			
19. KEY WORDS (Continue on reverse side if necessary and identify by block number) Extreme Ultraviolet, Ultraviolet, Monochromators, Spectrometers, Spectrophotometers, Photometers, Instrumentation, Rockets, Detec- tors, Vacuum, Field Services, Rocket Launches, Upper Atmosphere Physics, Solar Radiation, Ground Support Equipment (GSE), Electronics, Flight Electronics			
20. ABSTRACT (Continue on reverse side if necessary and identify by block number) This report describes the design, development, and fabrication of two solar extreme ultraviolet double spectrometers for sounding rockets. Both instruments are of the grazing-incidence grating spectrometer design. The report also describes the design and fabrication of ground support equipment (GSE) for the two instru- ments and field services supporting the launch of two instruments.			

DD FORM 1 JAN 73 1473

EDITION OF 1 NOV 65 IS OBSOLETE

UNCLASSIFIED

SECURITY CLASSIFICATION OF THIS PAGE (When Data Entered)

094400

JB

SECURITY CLASSIFICATION OF THIS PAGE(When Data Entered)

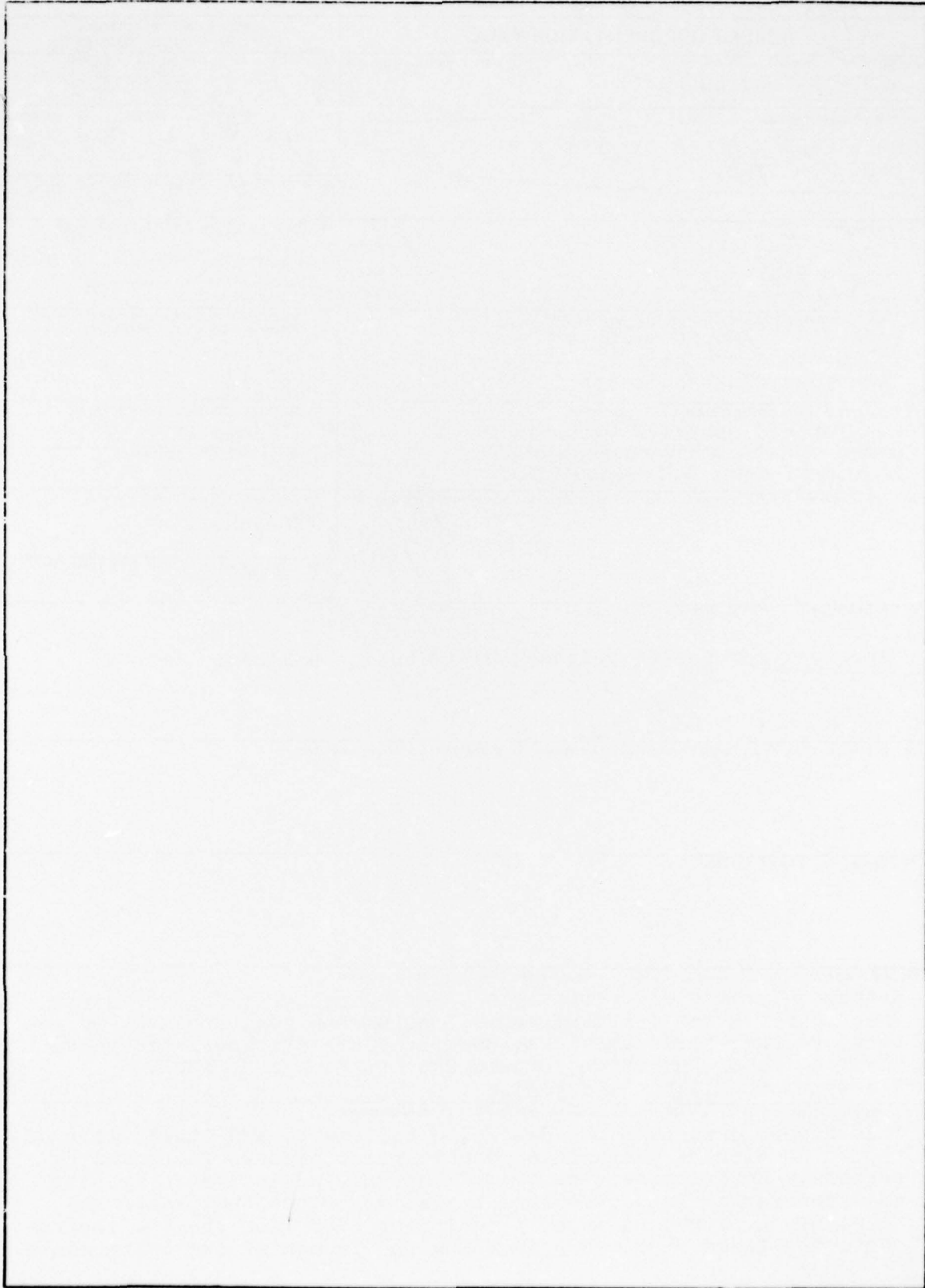

SECURITY CLASSIFICATION OF THIS PAGE(When Data Entered)

TABLE OF CONTENTS

1.	GENERAL	1
2.	RELATED CONTRACTS	3
3.	ROCKET SPECTROMETER NO. 59	5
3.1	Introduction	5
3.2	Instrument Package	6
3.3	Entrance Aperture	6
3.4	Grating Mount	15
3.5	Gratings	15
3.6	Detectors	16
3.7	Wavelength Scanning Subsystems	19
	3.7.1 Take-Up Pulley Assembly	19
	3.7.2 Drive Assembly	20
	3.7.3 Flexible Belt Drive	27
	3.7.4 Detector-Amplifier Carrier Assembly	27
	3.7.5 Detector Modules	27
3.8	Optical Alignment	28
3.9	Electronics for Rocket Spectrometer No. 59	28
	3.9.1 General Discussion	28
	3.9.2 Physical Configuration	35
	3.9.3 Circuit Description	36
	3.9.4 Commutator	49
3.10	Ground Support Equipment for RM-59 and RM-60	50
	3.10.1 General Discussion	50
	3.10.2 Technical Description	55
	3.10.3 Readouts/Controls/Operation	69
	3.10.4 Performance	72
3.11	Testing and Calibration	73
	3.11.1 Detector Tests	73
	3.11.2 Acceptance Tests	73
3.12	Field Support Services	74
4.	ROCKET SPECTROMETER NO. 60	75
4.1	Introduction	75
4.2	Instrument Package	75
4.3	Entrance Aperture	75
4.4	Grating Mount	79
4.5	Gratings	79
4.6	Detectors	79

ACCESSION TO	RTIS	DTIC	UNANNOUNCED	JUSTIFICATION
White Service				
ENT SERVICE				
37 OF THE PUBLIC AVAILABILITY GROUP MAIL ROOM OF SPC/AF				

4.7	Wavelength Scanning Subsystem	86
4.7.1	Take-Up Pulley Assembly	86
4.7.2	Drive Assembly	86
4.7.3	Flexible Belt Drive	86
4.7.4	Detector Amplifier Carrier Assembly	87
4.8	Optical Alignment	87
4.9	Electronics for Rocket Spectrometer No. 60	87
4.9.1	General	87
4.9.2	Physical Configuration	88
4.9.3	Circuit Description	88
4.9.4	Commutator	89
4.10	Testing and Calibration	89
5.	ROCKET SPECTROMETER NO. 59-II	93
5.1	General	93
5.2	Electron Spectrometer Electronics	93
5.2.1	Ground Support Equipment	97
5.3	Photometer Electronics	116
5.3.1	Ground Support Equipment	131
5.4	Field Support Services	131

LIST OF TABLES

TABLE I	11
Technical Characteristics of Rocket Spectrometer #59	
TABLE II	77
Technical Characteristics of Rocket Spectrometer #60	

LIST OF FIGURES

Figure 1	7
Proposed Double Deck Spectrometer	
Figure 2	9
Photograph - Rocket Spectrometer No. 59	
Figure 3	13
Slit Assembly (.001)	
Figure 4	17
Grating Mount Assembly	
Figure 5	21
Take-Up Pulley Assembly	
Figure 6	23
Belt Drive Unit	
Figure 7	25
Switch Actuator Assembly	
Figure 8	29
S.W. Channeltron Assembly	
Figure 9	33
Timing Diagram	
Figure 10	37
Block Diagram	
Figure 11	41
Motor Drive/Timer RM-59	
Figure 12	43
Photon Counter/Shift Register	
Figure 13	45
PS/Test/Output Schematic	
Figure 14	47
Pulse Amp Channeltron	
Figure 15	51
Commutator	
Figure 16	53
Photograph - Rocket Spectrometer 59/60 GSE Console	
Figure 17	57
Block Diagram Console RM-59/60	
Figure 18	59
Timing Diagram Console RM-59/60	
Figure 19	61
Timer Console III	

Figure 20	83
Data Decode/Display Console	
Figure 21	65
Time Base, Square Wave Counter Console	
Figure 22	67
Franklin Printer Drive Console	
Figure 23	81
Internal Assembly RM-60 Collimator	
Figure 24	83
Collimator and Eye Block Assembly	
Figure 25	91
Schematic - Motor Drive/Timer RM-60	
Figure 26	95
Timing Diagram Electron Spectrometer	
Figure 27	99
Schematic - Timer Electron Spectrometer	
Figure 28	101
Schematic - Test/Output Electron Spectrometer	
Figure 29	103
Counter/Shift Register Electron Spec/Photometer	
Figure 30	105
Step Generator Electron Spectrometer	
Figure 31	107
Block Diagram - Electron Spectrometer	
Figure 32	109
Block Diagram - Console Electron Spectrometer	
Figure 33	111
Timing Diagram - Console Electron Spectrometer	
Figure 34	117
Schematic - Timer Console Electron Spectrometer	
Figure 35	119
Schematic, Step Decode Electron Spectrometer Console	
Figure 36	121
Time Base/Square Wave Counter - Electronic Spectrometer/Photo Console	
Figure 37	123
Block Diagram - Photometer	
Figure 38	125
Timing Diagram - Photometer	

Figure 39	127
Timer Photometer RM-59-II	
Figure 40	129
Schematic P.S., Output Photometer	
Figure 41	133
Timing Diagram Photometer, Console	
Figure 42	135
Schematic, Timer Photometer Console	

1. GENERAL

This report covers the design, development, and engineering activities of Comstock & Wescott, Inc. in support of a research program of the Air Force Geophysics Laboratory (AFGL). The work discussed in this report covers the design, development, and fabrication of two double-deck grazing incidence grating spectrometers (RM-59 and RM-60). It also includes the integration of two Government furnished auxiliary experiments.

The principal engineers on this contract were

Mr. John F. McGrath,
Director of Mechanical Engineering, and

Mr. Joseph P. Padur,
Project Physicist.

Work in the field of electronics, including the flight electronics and ground support equipment (GSE), was subcontracted to TRI-CON Associates, Inc. and was conducted under the direction of Mr. Chester G. Kuczun and Mr. Robert S. Hills. Other technical contributors to the contract were Messrs. Charles W. Peterson, William F. Burke, and George W. Guay of Comstock & Wescott, Inc., and Messrs. Norbert F. Robertie and Timothy A. Doyle of TRI-CON Associates, Inc.

2. RELATED CONTRACTS

The following contracts have preceded the contract covered by this report:

AF19(604)-1097, 1954 to 1956.

Contract concerned with development of a soft X-ray radiation source and an associated high vacuum system.

AF19(604)-1889, 1956 to 1959.

Measurements of EUV and soft X-rays.

AF19(604)-5693, 1959 to 1961.

Investigation of extreme ultraviolet solar radiation and clarification of role of photoelectron emission.

AF19(604)-7496, 1960 to 1963.

Development of a number of rocket and satellite monochromators and retarding potential detectors. Specific reference is made to the Final Report AFCRL-64-773 of this contract.

An associated contract which ran concurrently with AF19(604)-7496 was AF19(628)-2975.

This was concerned with research into the photoemission properties of materials and with the investigation and development of various spectroscopic instruments.

AF19(628)-4317 was an extension of AF19(604)-7496.

Contract AF19(628)-5188 covered a further extension of this work.

Contract F19628-68-C-0239 covered an extension of the work performed under the former contract and preceded the work covered by this report.

Contract F19628-72-C-0048 covered a modification of a Double-Deck EUV Spectrophotometer.

Contract F19628-72-C-0254 covered design, development, and fabrication of a double spectrophotometer consisting of one grazing incidence and one normal incidence grating spectrophotometer.

Other contracts carried out by Comstock & Wescott in the field of space instrumentation, but not directly related to this contract, are:

AF19(628)-253 - Research directed toward Design of Instrumentation for Investigation of Aerospace by Rocket and Satellite Probe Techniques.

AF19(628)-4988 - Rocket and Satellite Probe Techniques.

F19628-68-C-0307 - Continuation of AF19(628)-4988.

F19628-72-C-0027 - Continuation of F19628-68-C-0307.

3. ROCKET SPECTROMETER NO. 59

3.1 Introduction

RM-59 was a grazing incidence, double-deck spectrometer designed to measure eight fixed wavelengths continuously during a rocket flight as part of the Aladdin 74 program. The eight selected wavelengths were: 284\AA , 304\AA , 584\AA , 630\AA , 736\AA , 912\AA , 1026\AA , and 1206\AA .

The instrument was a Rowland mount spectrometer designed for use with two meter radius of curvature gratings, illuminated at an angle of incidence of 86 degrees from the grating normal. There were two parallel optical paths (decks) with entrance aperture, grating, scanning and detection systems and electronics, independently and simultaneously operated to monitor the eight specified wavelengths in the solar spectrum. Earlier versions of this type of instrument are described in the following references:

- (a) Wiederhold, P. R. and J. F. McGrath, Jr., "Instrumentation for Studies of Solar Extreme Ultraviolet Radiation," Final Report, November 1968, Contract AF19(628)-5188, Comstock & Wescott, Inc., Cambridge, Mass. AFCRL-69-0004.
- (b) Padur, J. P., J. F. McGrath, Jr., and P.R. Wiederhold, "Instrumentation for Studies of Solar XUV Radiation," Final Report, February 1972, Contract AF19628-68-C-0239, Comstock & Wescott, Inc., Cambridge, Mass. AFCRL-72-0133.

3.2 Instrument Package

The magnesium spectrometer package as originally proposed is illustrated in Figure 1. Figure 2 is a reproduction of a photograph of the instrument as delivered to AFGL for calibration. Table I contains a summary of the technical characteristics of this instrument. Descriptions of the individual components are given in the following sections.

3.3 Entrance Aperture

The entrance aperture for each deck was similar to the one shown in Figure 3 which includes an electroformed slit, etched slit height limiter, and polarized aperture plates. The slits were of electroformed nickel on a base of beryllium copper, and had a high degree of dimensional accuracy (as well as sharp slit edges) due to the inherent accuracy of the photoforming manufacturing process. One side of the slit housing was used as a reference surface to align the slit, and was also used for temporary mounting of an optical target in the optical alignment procedure.

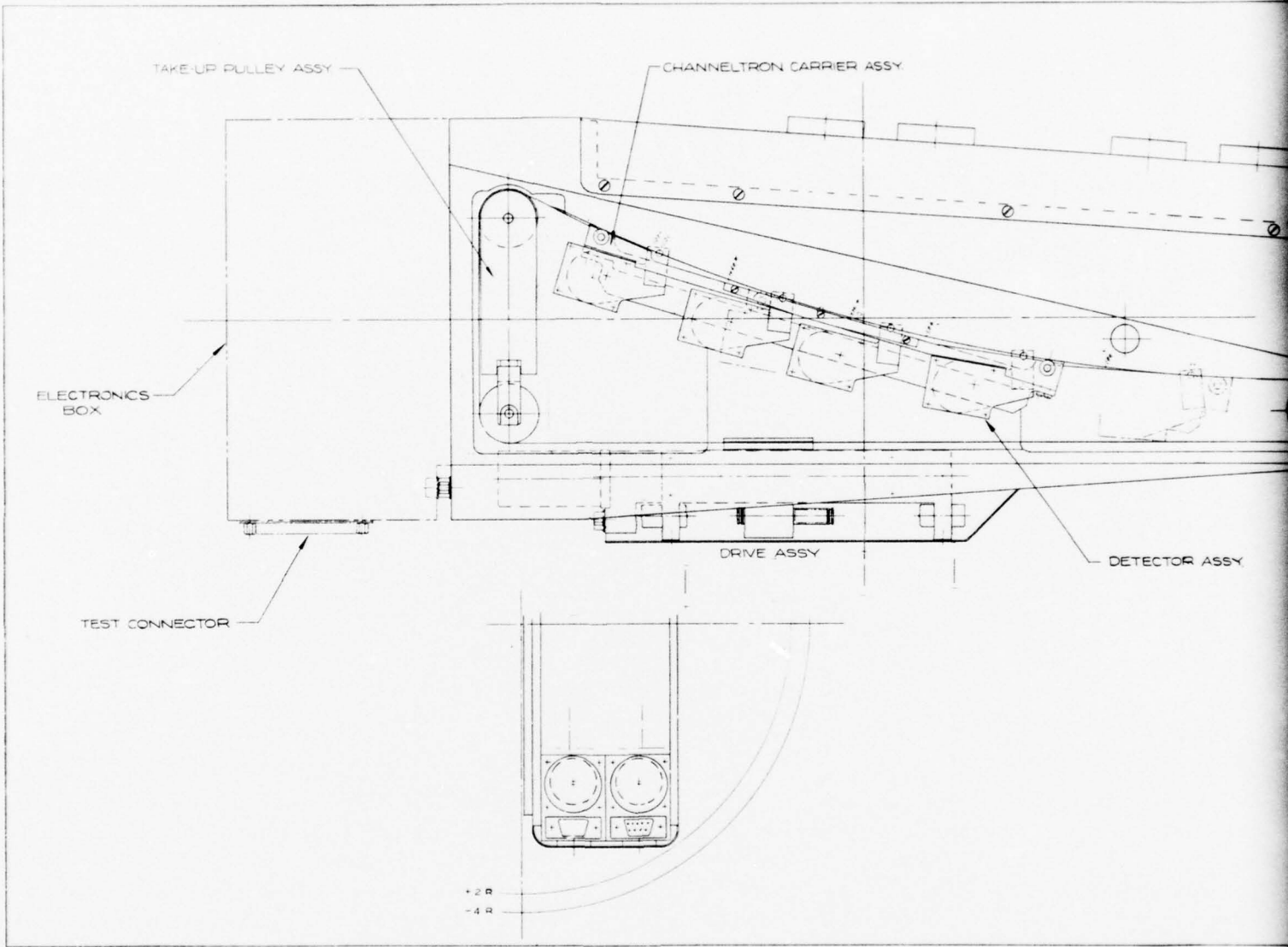

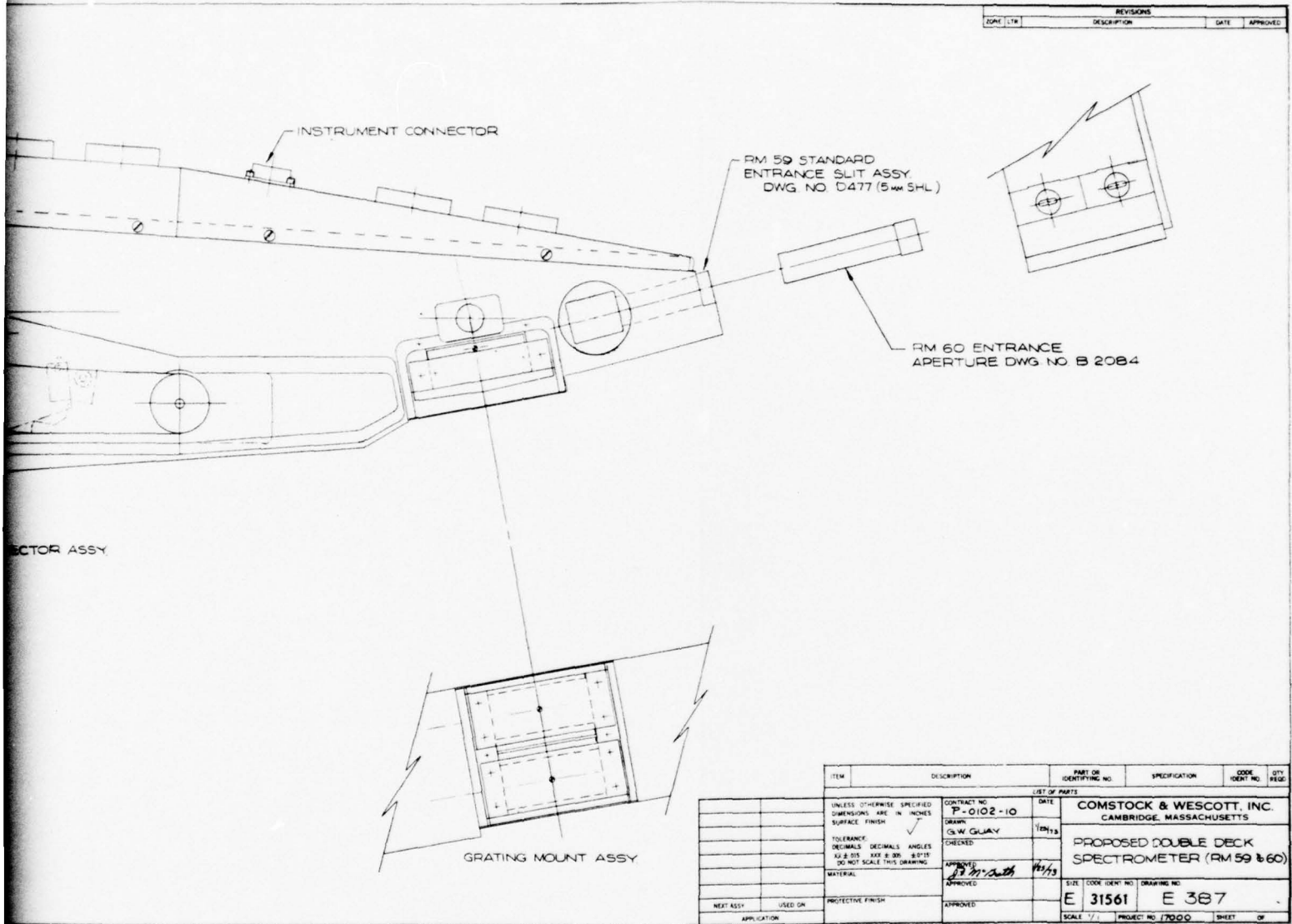

REVISIONS			
DATE	DESCRIPTION	DATE	APPROVED

ITEM	DESCRIPTION	PART OR IDENTIFYING NO.	SPECIFICATION	CODE IDENT NO.	QTY.
LIST OF PARTS					
	UNLESS OTHERWISE SPECIFIED DIMENSIONS ARE IN INCHES SURFACE FINISH	CONTRACT NO. P-0102-10 DATE 1/28/53	COMSTOCK & WESCOTT, INC. CAMBRIDGE, MASSACHUSETTS		
	TOLERANCE DECIMALS ANGLES .001 & .015 .001 & .001 .015 DO NOT SCALE THIS DRAWING	CHECKED G.W. GLAV	PROPOSED DOUBLE DECK SPECTROMETER (RM 59 & 60)		
	MATERIAL	APPROVED <i>P. Smith</i> 1/13	SIZE	CODE IDENT NO.	DRAWING NO.
	NEXT ASSY	USED ON	E 31561	E 387	
	PROTECTIVE FINISH	APPROVED	SCALE 1/1	PROJECT NO. 17000	SHEET OF
	APPLICATION				

Figure 1. Proposed Double Deck Spectrometer

Handwritten mark

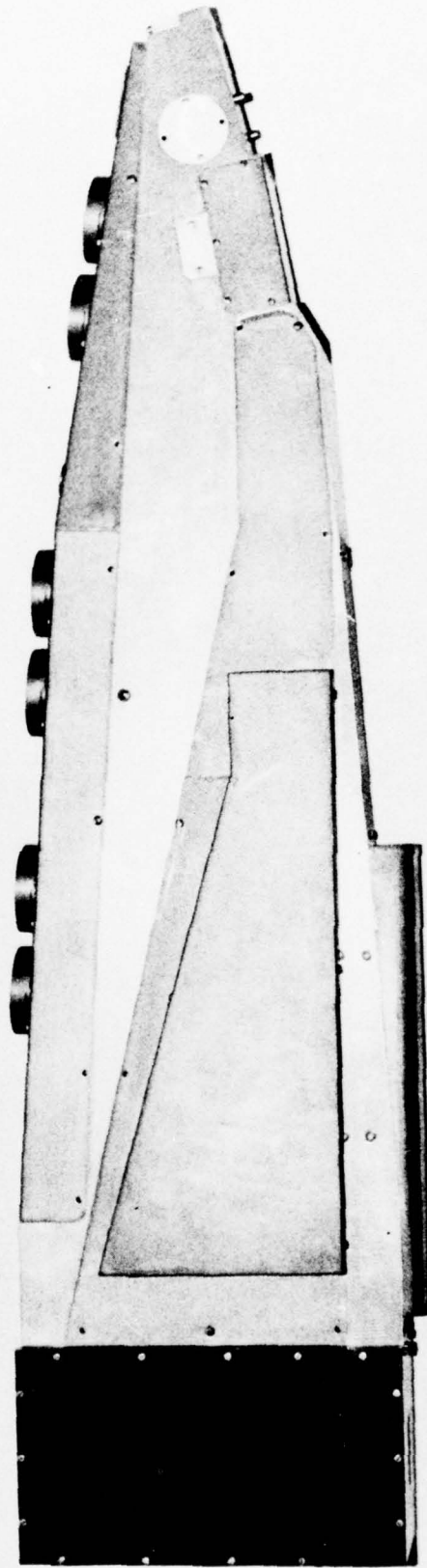
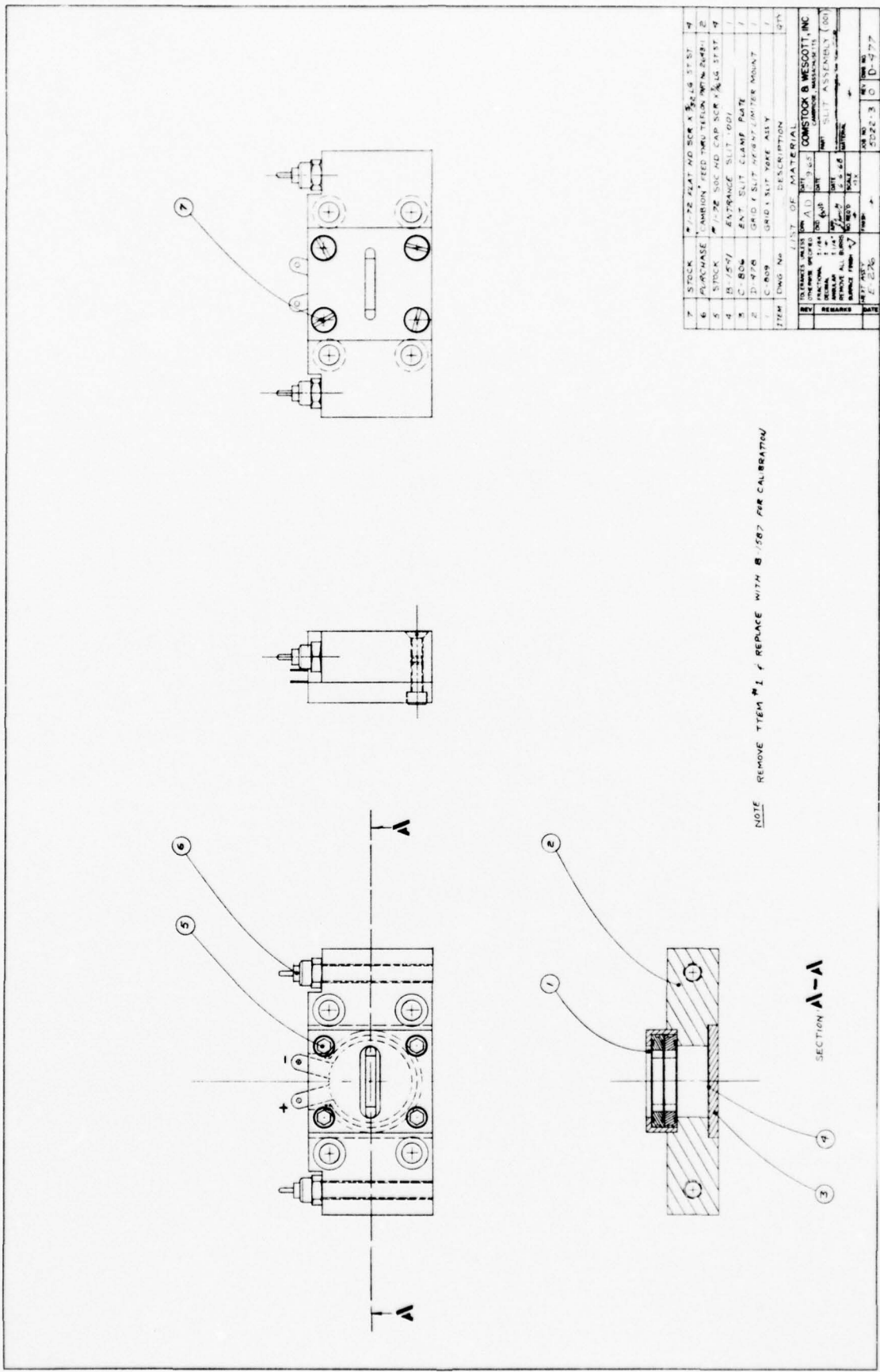

Figure 2. Rocket Spectrometer No. 59

TABLE I

TECHNICAL CHARACTERISTICS OF ROCKET SPECTROMETER NO. 59

	Top Deck	Bottom Deck
Entrance Slit	.05 mm	.05 mm
Slit Height Limiter	4 mm	4 mm
Grating	300 ℓ /mm gold replica	300 ℓ /mm gold replica
Exit Slit	.127 mm	.127 mm
Detectors	4 channel electron multipliers	4 channel electron multipliers
Wavelengths Covered	304 \AA , 630 \AA , 912 \AA , 1206 \AA	284 \AA , 584 \AA , 736 \AA , 1026 \AA
Steps per Scan	20	20
Distance per Step	.127 mm	.127 mm
Duration of Scan	2 sec	2 sec
Stepping Rate	10 steps/sec	10 steps/sec
Resolution	2.2 \AA FWHM	2.2 \AA FWHM
Filter	Al filter with 304 \AA Detector	None



ITEM	QTY	DESCRIPTION	UNIT	REVISION
7	1	GRID SLIT TUBE ASSY		
6	1	GRID SLIT CLAMP PART		
5	1	GRID SLIT MOUNT (MOUNT)		
4	1	EXTENSIVE SLIT (001)		
3	1	GRID SLIT MOUNT (MOUNT)		
2	1	GRID SLIT TUBE ASSY		
1	1	GRID SLIT TUBE ASSY		

REV	REVISION	DATE
1	INITIAL	
2	REVISION	
3	REVISION	
4	REVISION	
5	REVISION	
6	REVISION	
7	REVISION	

TO ORDER	UNIT	QTY	REVISION
COMSTOCK & WESCOTT, INC.			
1000 WASHINGTON ST.			
ROSLINDALE, MASSACHUSETTS			
PHONE: 617-882-1100			
FAX: 617-882-1101			
TELETYPE: 617-882-1102			
INTERNET: WWW.COMSTOCK-AND-WESCOTT.COM			

Figure 3. Slit Assembly (.001)

3.4 Grating Mount

The grating mount for each deck consisted of a stiff, accurately-ground base plate with three reference surfaces for positioning of the grating. Clamps for the grating were provided opposite the three reference surfaces to apply clamping force through cyclized rubber pads. Each assembly was removable from the instrument as a unit without disturbing the grating clamps. Mounting surfaces were provided in the instrument which were machined to the accuracy needed to assure the maintenance of proper focus on the Rowland circle at all wavelengths within the range of the instrument. Figure 4 illustrates the grating mount assembly.

3.5 Gratings

The gratings for this instrument were two identical gold coated replicas (Bausch & Lomb Catalog No. 35-52-39-30) with the following characteristics:

Ruling	300 grooves/mm
Ruled Area	32 mm ruled width 24 mm groove length
Blaze Wavelength	4650 \AA
Blaze Angle	4 $^{\circ}$ 00'
Grating Blank	1986 mm radius, fused quartz

Provisions were made for visual verification of the instrument alignment (entrance slit, grating, and exit slits) during integration with the solar pointing control. These provisions included a means of determining whether the solar visible radiation was illuminating the grating

properly in the elevation and azimuthal planes. In order to check whether this radiation did pass through the exit slit in the azimuthal plane, a grating substitute was provided, enabling one to traverse the visible radiation along the entire Rowland circle.

3.6 Detectors

Four (4) Galileo Model #4500 channel electron multipliers (CEM's) were used in each deck for measuring the diffracted radiation. These detectors were potted in an elastomer and positioned behind their respective exit slits with the cone portion of the channel at grazing incidence to the diffracted radiation. Prior to assembly in the instrument, each of the CEM-amplifier combinations were shown to exhibit a well defined counting plateau for count rates up to 100,000 counts per second when illuminated with EUV radiation. The CEM's were operated with a positive potential of 3,000 volts on the anode with respect to ground; 400 volts on the throat, and about 20 volts on the cone entrance for charged particle rejection. Each CEM was also well shielded to reject any radio frequency interference. The background count rate was less than one count per second for each of the units. The amplifiers were mounted atop the CEM assemblies with minimum lead length to reduce unwanted pickup.

Provisions for alignment of the exit slits with respect to the entrance slit were supplied in the exit slit mounts. This adjustment was in the plane perpendicular to the plane of dispersion of the grating and was optically referenced to the grating normal.

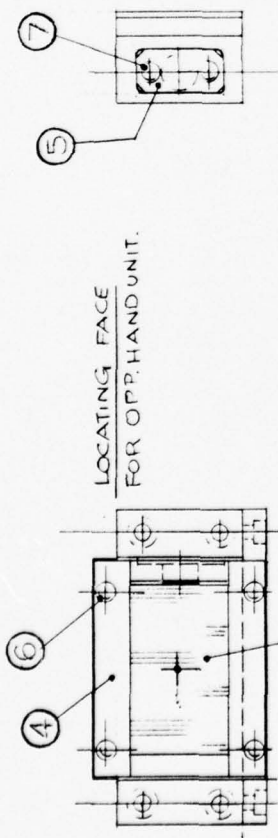

1, UNIT CAN BE ASSEMBLED AS AN OPPOSITE HAND UNIT DEPENDING ON FLIGHT POSITIONS OF TWO INSTRUMENTS (TYPE I)

ITEM	DESCRIPTION	PART OR IDENTIFYING NO.	SPECIFICATION	CODE IDENT. NO.	QTY. REQD.
7	FLAT HD. SCREW		#4-40 X 3/16 LG		2
6	SOC. HD. CAP. SCREW		#4-40 X 5/16 LG		8
5	PRESSURE PAD	B1993			1
4	GRATING CLAMP	B1994			1
3	SIDE PANEL	B1995			1
2	SIDE PANEL	B1992			1
1	GRATING MOUNT BODY	C1116			1

Figure 4. Grating Mount Assembly

During the calibration of this instrument, three detectors failed at various times. Past experiences have revealed shorts and/or opens in either of the three leads from the CEM but never a complete breakdown of the CEM, so they were replaced without full knowledge of the cause. When the problem again arose with RS-60, an investigation of the manufacturing process of the detectors was undertaken. The results of this investigation are given in Section 4.6.

3.7 Wavelength Scanning Subsystems

Each wavelength scanning system consisted of a detector/amplifier carrier assembly, a flexible drive belt, a motor drive assembly, and a take-up pulley assembly. Each deck was designed to scan across four spectral lines in the EUV in two seconds, with data points on either side of the peak count, for background correction. The data sampling time was 100 milliseconds in both decks.

3.7.1 Take-Up Pulley Assembly

The take-up pulley assembly is illustrated in Figure 5 and consisted of one pulley supported by a single housing at the rear of the Rowland circle. It contained sprocket pins, was adjustable, and accommodated a certain amount of belt misalignment through the use of a gimbaled mounting arrangement. The housing contained a thumbscrew-actuated adjustment mechanism that provided a predetermined amount of belt tension with amplitude restraint to prevent belt disengagement during vibration. Adjustment of the thumbscrew

to a position midway between its end-position stops (approximately 1/32 inch) provided the proper belt tension.

3.7.2 Drive Assembly

The drive assembly for each deck consisted of a 28-volt permanent magnet dc motor with a 90° step increment, an integral gearhead, a flexible coupling, a recirculating ball lead screw, drive belt bracket and counterweight, limit switches, and housing. It is shown in Figure 6.

The lead screw had a pitch of 0.100 inch. When driven through a gearhead with a reduction ratio of 10:1, it produced a linear motion of the drive belt bracket of .0025 inch per step of the motor.

A modification in the electronic design was made in order to "double-step" the motor in the flight mode so that the drive belt bracket would increment by .005 inch. This modification will be discussed in the electronics section.

Limit switches were adjustable for any desired scanning range. The switch actuators had overtravel plungers designed to prevent damage to the switches (Figure 7).

The switches used were Texas Instruments Type AT-362.

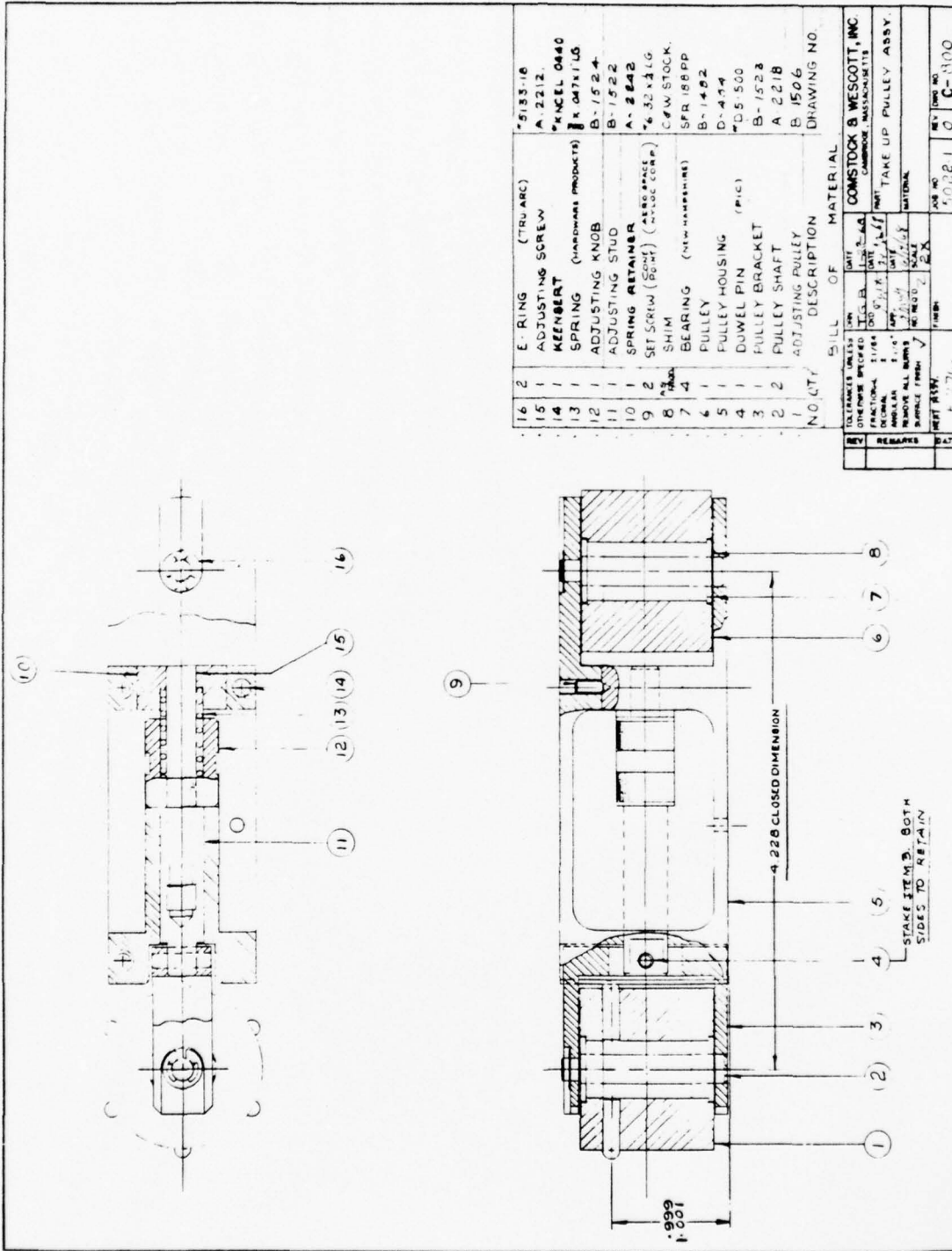
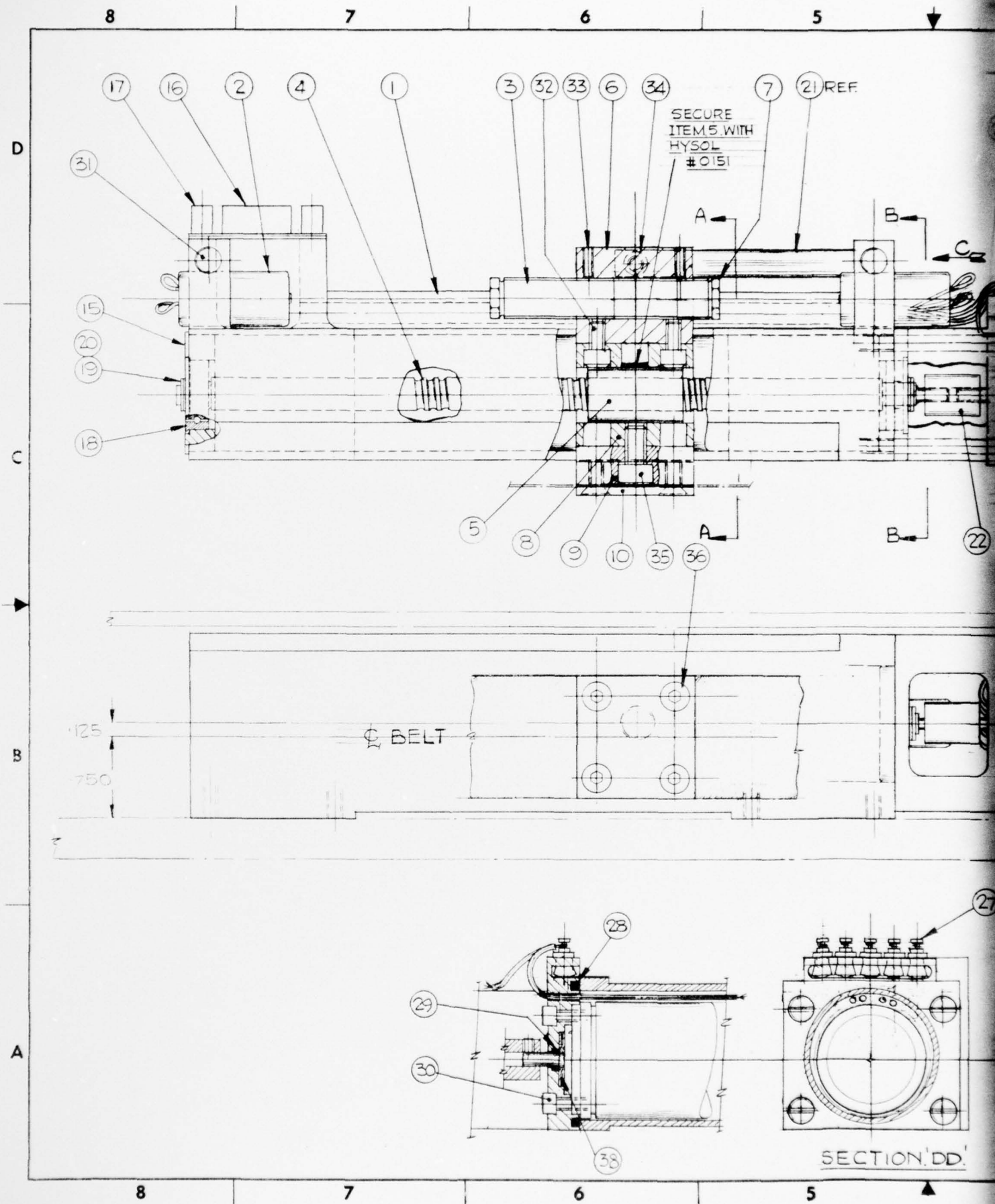
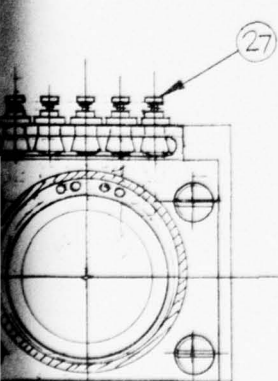
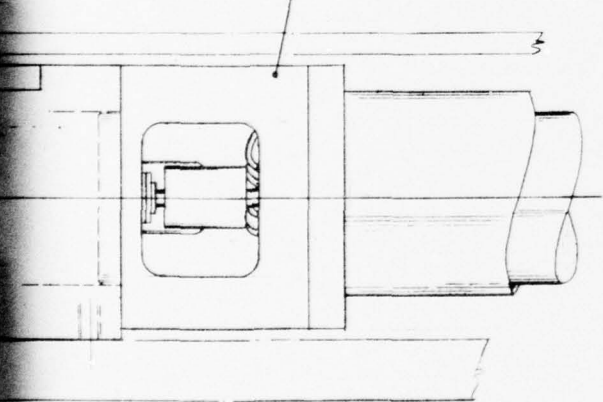
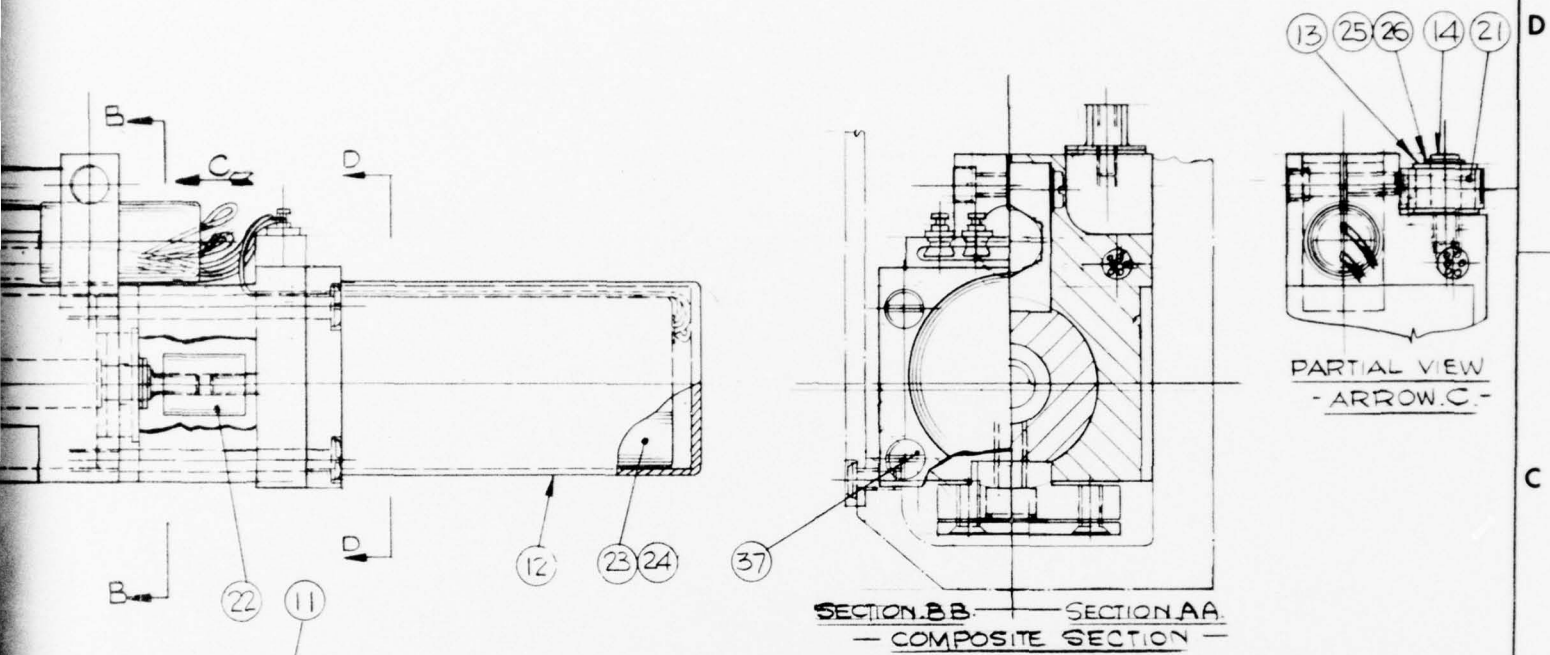

Figure 5. Take-Up Pulley Assembly



REVISIONS				
ZONE	LTR	DESCRIPTION	DATE	APPROVED

REF



38	SEAL RETAINER	B 2009			1
37	BINDER HEAD SCREW	ST ST	#6-32 X 1/2		4
36	FLAT HD. CAP SCREW	ST ST	#4-40 X 1/2		4
35	SOC. HD. CAP SCREW	ST ST	#8-32 X 1/2		1
34	PAN HD. SCREW	ST ST	#4-40 X 1/2		1
33	SOC. HD. SET SCREW	ST ST	#2-56 X 1/8		1
32	SOC. HD. CAP SCREW	ST ST	#6-32 X 1/2		1
31	SOC. HD. CAP SCREW	ST ST	#6-32 X 1/2		1
30	SOC. HD. CAP SCREW	ST ST	#4-40 X 1/2		1
29	SEAL	ARADT-ALLISON G	#004108530A	REFLON	1
28	O RING		#2-24		1
27	INSULATED TERMINAL	SEAELECTRO	STEM 2 FTUR		5
26	SHIMS	PIC	BB-24		1
25	RETAINING RING	PIC	22-2		1
24	MOTOR				1
23	GEARHEAD				1
22	COUPLING	HELI-CAL	#40320-44		1
21	NEGATOR	HUNTER SPINS	F 5H4D12		1
20	SHIM	PIC	BB-24		1
19	RETAINING RING	PIC	22-2		1
18	BEARING	FARNER	AMMVESIK007		1
17	FEMALE SCREW LOCK	CANNON	D204B-2		1
16	5 PIN CONNECTOR	CANNON	DE DP		1
15	BEARING HOUSING	A 2669			1
14	NEGATOR SPOOL SHAFT	A 2667			1
13	NEGATOR SPOOL	A 2668			1
12	MOTOR GEARHEAD COVER	B 2004			1
11	TRANSITION BLOCK	E 1121			1
10	BELT CAPRON PLATE	A 2672			1
9	BELT SUPPORT BLOCK	B 2007			1
8	NOT HOUSING	B 2003			1
7	SWITCH ACTUATOR ASSY	A 2418			1
6	ADJUSTMENT SCREW SUPPORT	B 2003			1
5	BALL SCREW NUT	A 2645			1
4	BALL SCREW	A 2001			1
3	SWITCH ACTUATOR ASSY	B 1875			1
2	REVERSING SWITCH ASSY	A 2670			1
1	BELT DRIVE BODY	D 753			1

ITEM	DESCRIPTION	PART OR IDENTIFYING NO.	SPECIFICATION	CODE IDENT NO.	QTY REQD.
LIST OF PARTS					
UNLESS OTHERWISE SPECIFIED DIMENSIONS ARE IN INCHES SURFACE FINISH 64		CONTRACT NO. 72-0254 DATE 6/5/72		COMSTOCK & WESCOTT, INC. CAMBRIDGE, MASSACHUSETTS	
TOLERANCE DECIMALS ANGLES XX ± 0.15 XXX ± 0.05 ± 0°15' DO NOT SCALE THIS DRAWING		DRAWN <i>Quinn</i> CHECKED <i>RMA</i> APPROVED <i>SM</i>		BELT DRIVE UNIT	
MATERIAL E 370		APPROVED		SIZE CODE IDENT NO. DRAWING NO. D 31561 D.754	
NEXT ASSY USED ON APPLICATION		PROTECTIVE FINISH		SCALE 2/1 PROJECT NO. 5029-2 SHEET 1 OF 1	

SECTION DD

REVISIONS		DATE	APPROVED
LTR	DESCRIPTION		

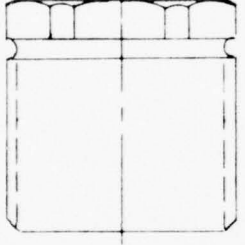
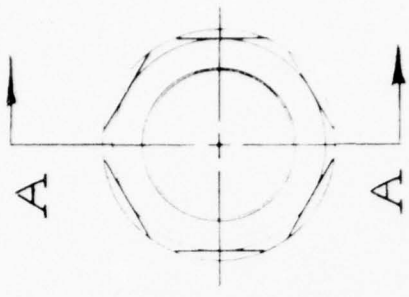
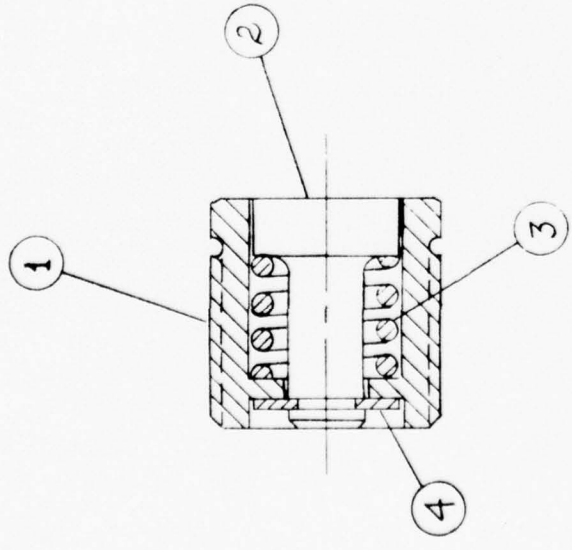

4		SNAP RING (TRUARC NO. 5133-12)	1
3		SPRING (HDWR PROD. 1/4 x .031 x 1/4 Lg.)	1
2	A2417-1	PLUNGER	1
1	B-1672	ACTUATOR HOUSING	1
ITEM	PART NO.	DESCRIPTION	QTY.
CONTRACT NO.		DATE	
AF 0239		5/2/69	
DRAWN			
JMW			
CHECKED			
APPROVED			
APPROVED			
APPROVED			
APPROVED			
COMSTOCK & WESCOTT, INC.		CAMBRIDGE, MASSACHUSETTS	
SWITCH ACTUATOR ASS'Y.			
SIZE	CODE IDENT NO	DRAWING NO.	
A	31561	A-2416	
SCALE	4X	PROJECT NO	5023-2
		SHEET	1 OF 1
			5023-7
UNLESS OTHERWISE SPECIFIED DIMENSIONS ARE IN INCHES			
SURFACE FINISH		✓	
TOLERANCE:		DECIMALS DECIMALS ANGLES	
XX ± .015 XXX ± .005 ± .0°15'			
MATERIAL			
D-736	AM-57		
D-566	AM MOD. 5023		
NEXT ASSY	USED ON		
APPLICATION			

SECTION AA

MODERN BLUE PRINT CO., INC. K426

Figure 7. Switch Actuator Assembly

3.7.3 Flexible Belt Drive

The drive belt was manufactured from 4 mil heat-treated beryllium-copper strip and fixed to the two axles on the detector-amplifier-carrier assembly.

3.7.4 Detector-Amplifier Carrier Assembly

The D-A carriers were manufactured from aluminum alloy and mounted four detector-amplifier exit slit modules on the Rowland circle so that four bands of wavelength would be covered when the carrier was scanned through the total wavelength range. The carriers rode on the machined Rowland circle on four wheels, consisting of ABEC-7 class ball bearings.

3.7.5 Detector Modules

The detector modules were similar to units supplied on previous contracts and are typified in Figure 8 showing the module less amplifier.

The spiral detector was mounted in a Kel-F housing and potted in silicone rubber. The silicone compound used to support the detector was G.E. RTV-11.

3.8 Optical Alignment

Reference surfaces were provided on the grating seat and entrance and exit slits for mounting targets to be used in the optical alignment. The exit slits had a fixed slit-jaw spacing and their mount was adjustable to provide parallelism with the entrance slit to $\pm 2 \times 10^{-4}$ radians. The slits were mounted onto the Rowland circle so that the surface of the slit was normal to the dispersed radiation when the slit was at mid-scan.

3.9 Electronics for Rocket Spectrometer No. 59

3.9.1 General Discussion

A separate electronic subsystem was built for each deck of the instrument. Each subsystem included a high voltage power supply, a divider board, a pulse amplifier for each of the four detectors, and three logic cards, one of which mounted a dual plus and minus fifteen volt power supply.

The three logic cards of each deck were mounted in a single electronics box. Other than the common box and a common electrical connector, the electronics of each deck were entirely separate.

The current pulses from the four detectors were processed by the instrument electronics. The pulses were counted and the count

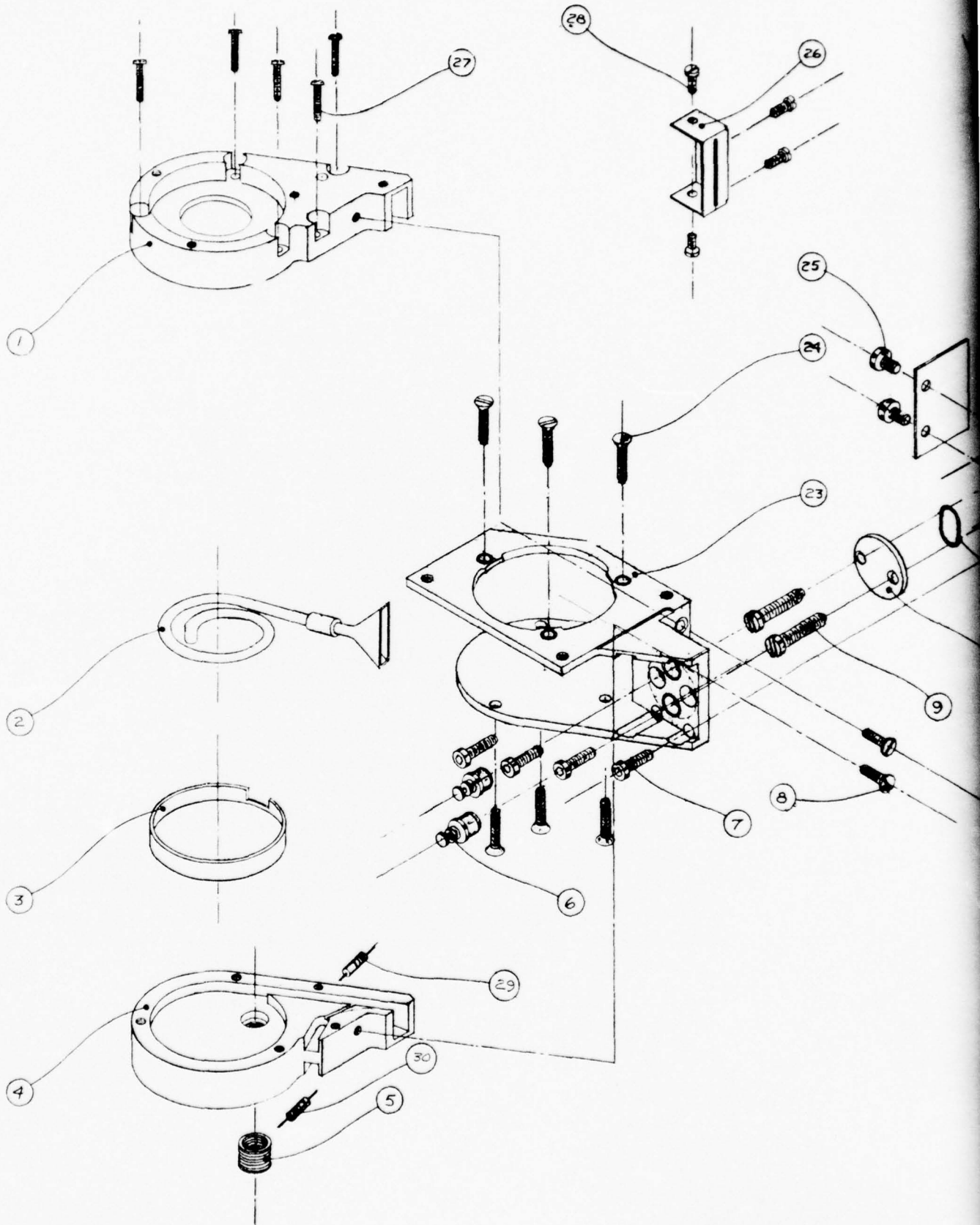

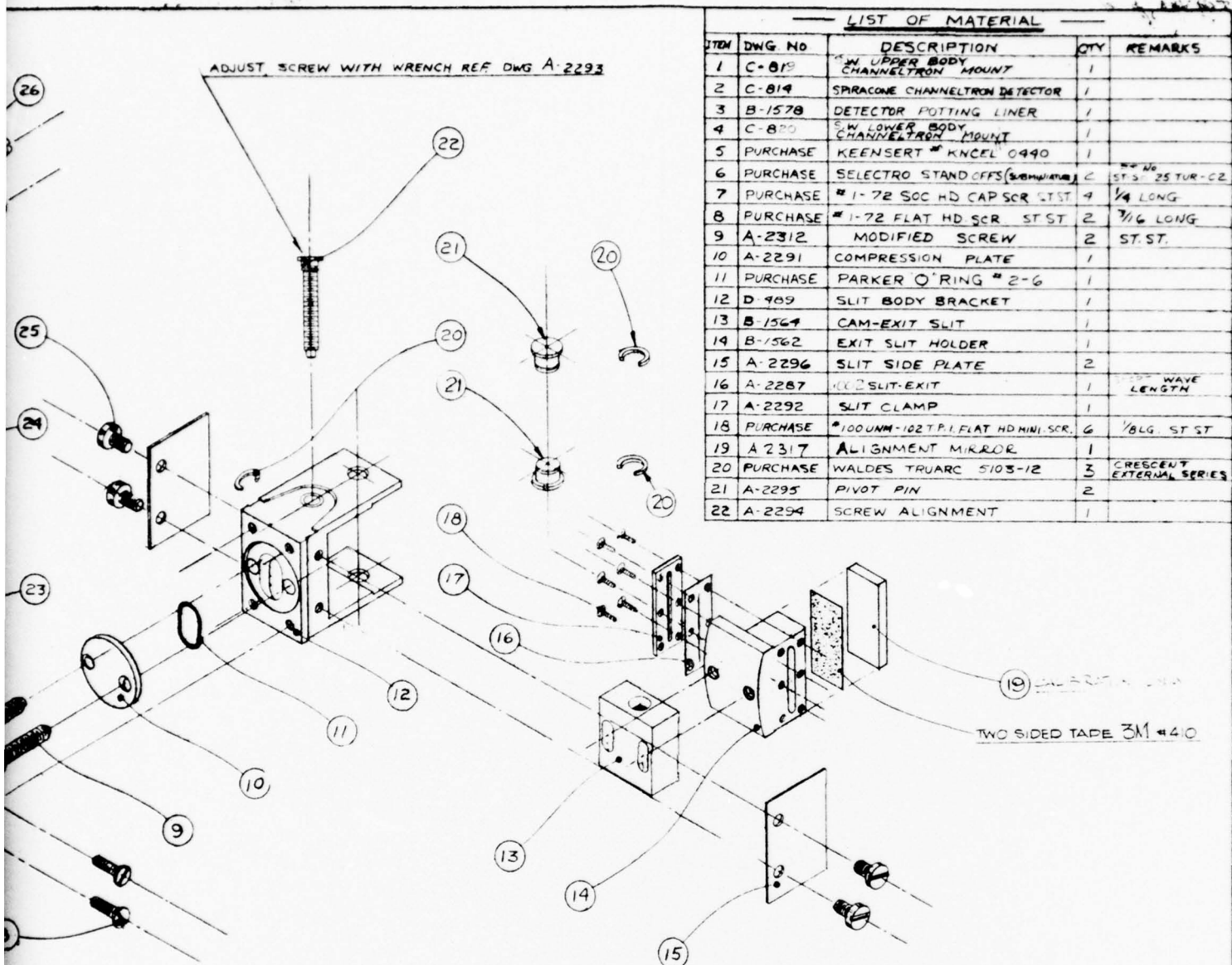

LIST OF MATERIAL

ITEM	DWG NO	DESCRIPTION	QTY	REMARKS
1	C-815	S.W. UPPER BODY CHANNELTRON MOUNT	1	
2	C-814	SPRACONE CHANNELTRON DETECTOR	1	
3	B-1578	DETECTOR POTTING LINER	1	
4	C-820	S.W. LOWER BODY CHANNELTRON MOUNT	1	
5	PURCHASE	KEENSERT # KNCCL 0490	1	
6	PURCHASE	SELECTRO STAND OFFS (SUBMITTER) C STS 25 TUR-C2	1	
7	PURCHASE	# 1-72 SOC HD CAP SCR ST ST	4	1/4 LONG
8	PURCHASE	# 1-72 FLAT HD SCR ST ST	2	3/16 LONG
9	A-2312	MODIFIED SCREW	2	ST. ST.
10	A-2291	COMPRESSION PLATE	1	
11	PURCHASE	PARKER O RING # 2-6	1	
12	D-989	SLIT BODY BRACKET	1	
13	B-1564	CAM-EXIT SLIT	1	
14	B-1562	EXIT SLIT HOLDER	1	
15	A-2296	SLIT SIDE PLATE	2	
16	A-2287	SLIT-EXIT	1	WAVE LENGTH
17	A-2292	SLIT CLAMP	1	
18	PURCHASE	#100UNM-102T.P.I. FLAT HD MINI. SCR.	6	1/8 LG. ST ST
19	A-2317	ALIGNMENT MIRROR	1	
20	PURCHASE	WALDES TRUARC 5103-12	3	CRESCENT EXTERNAL SERIES
21	A-2295	PIVOT PIN	2	
22	A-2294	SCREW ALIGNMENT	1	

23	D-500	DETECTOR MOUNTING BRKT	1	WAVE LENGTH
24	STOCK	#0-80 FLAT HD SCR ST ST	6	3/16 LONG
25	STOCK	#1-72 BINDER HD SCR ST ST	4	3/16 LONG
26	C-823	REJECTION SHIELD	1	WAVE LENGTH
27	STOCK	#0-80 PAN HD SCR ST ST	5	3/16 LONG
28	STOCK	#0-80 PAN HD SCR. ST. ST.	4	1/8 LONG
29		RESISTOR 1 MEG 1/4 WATT	1	
30		RESISTOR 100K 1/4 WATT	1	

REV	TOLERANCES UNLESS OTHERWISE SPECIFIED	DRN	A.D.	DATE	13 MAY 65	COMSTOCK & WESCOTT, INC. CAMBRIDGE, MASSACHUSETTS
REV	FRACTIONAL ±1/64 DECIMAL ±.005 ANGULAR ±1/4° REMOVE ALL BURRS SURFACE FINISH #7	QCD		DATE		
REV		APP		DATE	5-13-65	PART S.W. CHANNELTRON ASSY D/DECK MOND.
REV		NO RECD		SCALE	EX	MATERIAL
REV	D493	PHYS		JOB NO	5022-50	REV DWG NO 0 D-512

29 Figure 8. S.W. Channeltron Assembly 2

converted to a binary coded decimal number. The magnitude of the number is a function of the radiation intensity. The electronics also controlled the wavelength scan drive motor and generated a decimal number representing the wavelength of the radiation being processed by the detector electronics.

Each of the above decimal numbers, or words, consisted of four decimal digits and each digit was comprised of four binary coded decimal bits. In addition, a 16-bit synchronization word was generated which facilitated the computer data reduction.

The six words described above (sync word, scan position word, and four detector words) made up a PCM data frame consisting of 96 bits (6 words of 16 bits each). A separate PCM data channel was used for each deck.

The frame rate was the same as the scan stepping rate of 10 per second and was synchronized with it so that the scanner would move to the next position at the beginning of the PCM frame (Bit 1 of sync word). A timing diagram of the PCM data format and logic waveforms is given in Figure 9. Note that the first two bits

of the PCM data are of greater amplitude than the remaining bits. This permitted the start of each frame to be detected by amplitude discrimination, in lieu of digital techniques requiring comparison of 16 bits. Thus, the ground support equipment was greatly simplified to work reliably on clear strong signals present in the laboratory and prior to launch. The digital sync word was used by the computer for reducing actual flight data.

For flight the PCM data were brought through the interface connector and were used to modulate IRIG channels H and 19 sub-carrier oscillators in an S-band telemetry deck. These sub-carrier channels have a nominal rise time of 70 and 250 microseconds which is more than adequate for transmission of the PCM signal which has a non-return-to-zero form and a bit width of 1041.6 microseconds.

In addition to the PCM data signals containing the detector photon counts and wavelength information, three voltage monitors for each deck were also brought out to the interface connector and were commutated onto a low frequency sub-carrier oscillator. The commutator, described in a later paragraph, incorporated sixteen segments

XTAL OSC. 9.6 KHz

100 MS

96 BITS / FRAME
1.04167 MS / BIT

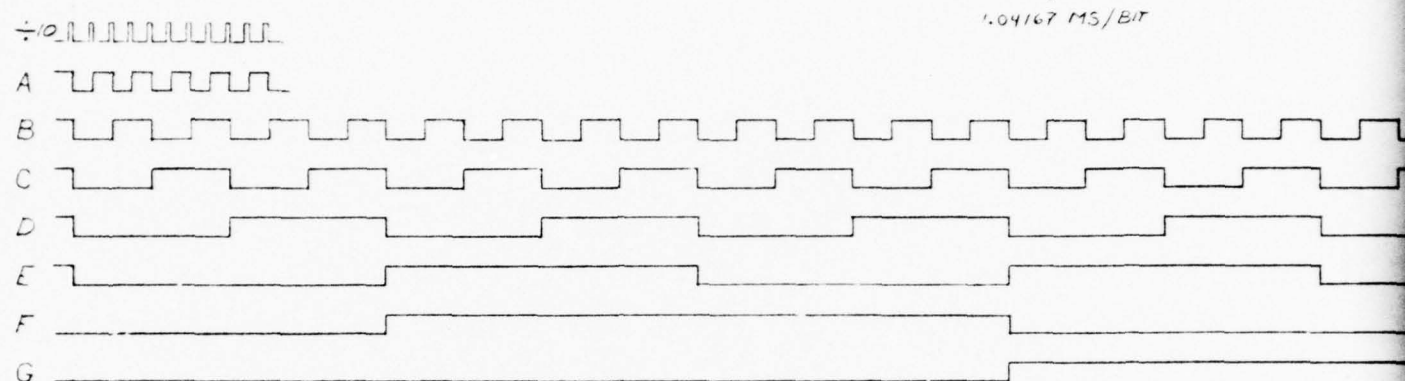
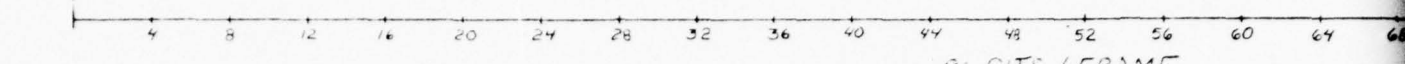

MT RM60
LOAD / FRAME SYNC

CLEAR

MOTOR TRIP RM59

COUNTS ADDED TO WL COUNTER AT BEGINNING OF MOTOR TRIP (RM59)

MOTOR PULSE RM59

COUNT ADDED TO WL COUNTER AT END OF MOTOR PULSE (RM60)

MOTOR PULSE RM60

12 MS

SW / INHIBIT

SSW

WL

SWL SHIFT

DET 1

S01

DET 2

S02

DET 3

S03

DET 4

S04

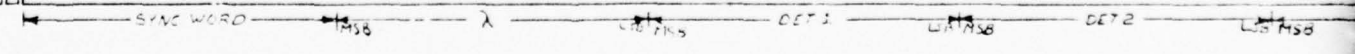

DATA FORMAT
124 MHz BIT
100 MS / FRAME

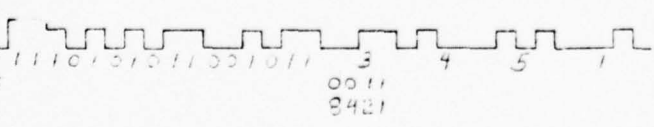

0011
9421

LOGIC

	E	F	G	
1	0	0	0	SYNC FF
2	1	1	0	WL EF
3	0	1	0	DET1 EF
4	1	0	1	DET2 EF
5	0	0	1	DET3 EF
6	1	0	0	DET4 EF

ZONE		LTR		REVISIONS		DATE	APPROVED
				DESCRIPTION			

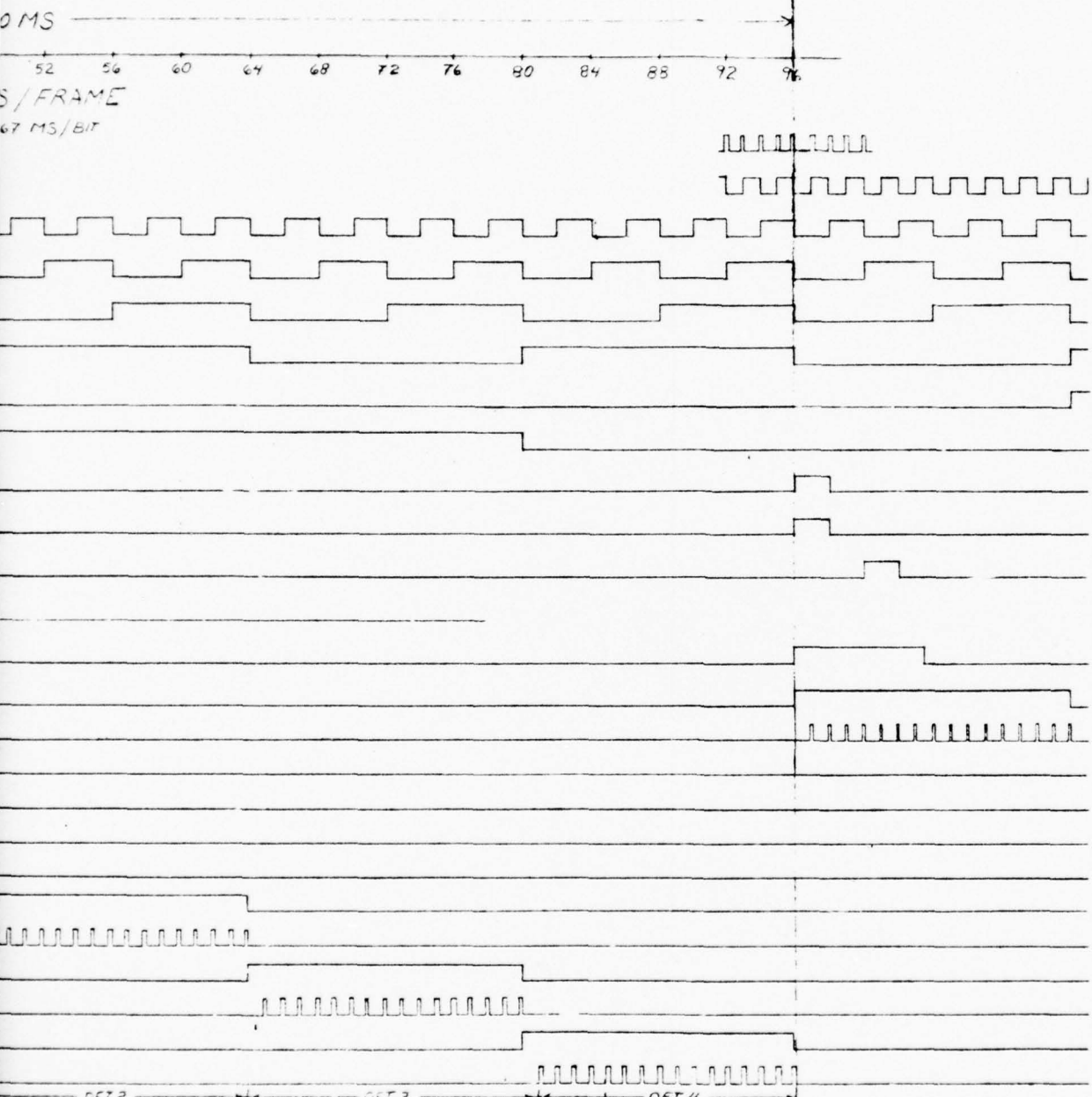

LOGIC

E	F	G	
0	0	0	SYAC EFF
1	1	0	WL EF
0	1	0	DET1 EF
1	0	1	DET2 EF
0	0	1	DET3 EF
1	0	0	DET4 EF

QTY	ITEM NO.	PART NO.	DESCRIPTION	CODE IDENT
			LIST OF MATERIALS	
UNLESS OTHERWISE SPECIFIED			CONTRACT NO. 24-25	Tri-Con Associates TIMING DIAGRAM RM-59/60 SIZE D CODE IDENT NO. 522 SCALE INT SHEET
TOLERANCES			DRAWN CHECKED ISSUED	
.00 ±			MECHANICAL	
.000 ±			ELECTRICAL PHILLS	
ANGLES ±			PHOTO OPTICAL	
✓ FINISHED SURFACE ROUGHNESS			STRUCTURAL	
CENTERS PERMISSIBLE			WEIGHTS	
DIMENSIONS IN INCHES AND APPLY AFTER PROCESSING			PROJ APPD	
APPROVED				
NEXTassy USED ON APPLICATION				

Figure 9. Timing Diagram

7

and each segment was sampled for two seconds. This sample time was chosen to permit the commutator output to be read on a simple voltmeter, the two seconds giving enough time for the monitor voltage to settle out and be observed before the commutator would move to the next segment. The monitors for each deck were:

- a) high voltage on the detectors,
- b) +13 volt internal power supply,
and
- c) -13 volt internal power supply.

The instrument operated from a 28-volt (nominal) silver cell battery with a one ampere-hour capacity located external to the instrument. The battery voltage was also monitored and commutated.

All the integrated circuit logic was of the complementary symmetry, metal oxide semiconductor (COS/MOS) type.

3.9.2 Physical Configuration

Each electronic system was made up of three sections: Four analog pulse amplifiers located on the channel-electron-multiplier assemblies on the moving carriage, three digital-logic cards located in a box at the rear of the instrument

housing, and high voltage assemblies board located on top of the housing. Dual (+13V, -13V) low voltage regulated power supplies were mounted on the digital-logic cards. Hence, all electronics were internal to the housing and shielded from receiving or producing external radio frequency interference. The card box was also shielded from the detectors and vented directly to the outside of the housing away from the instrument entrance aperture. The instrument electrical interface connectors were hard mounted to the housing to prevent the umbilical cable from dangling.

3.9.3 Circuit Description

A block diagram of the instrument electronics is given in Figure 10.

Each detector amplifier was used to feed pulses to a separate photon counter (consisting of four decade counters) on a single counter card. The binary-coded-decimal output from the counters representing the number of photons collected by the detector in 83.3 milliseconds was transferred to the 16-bit shift register and shifted out as words three through six to the PCM output line during the following frame.

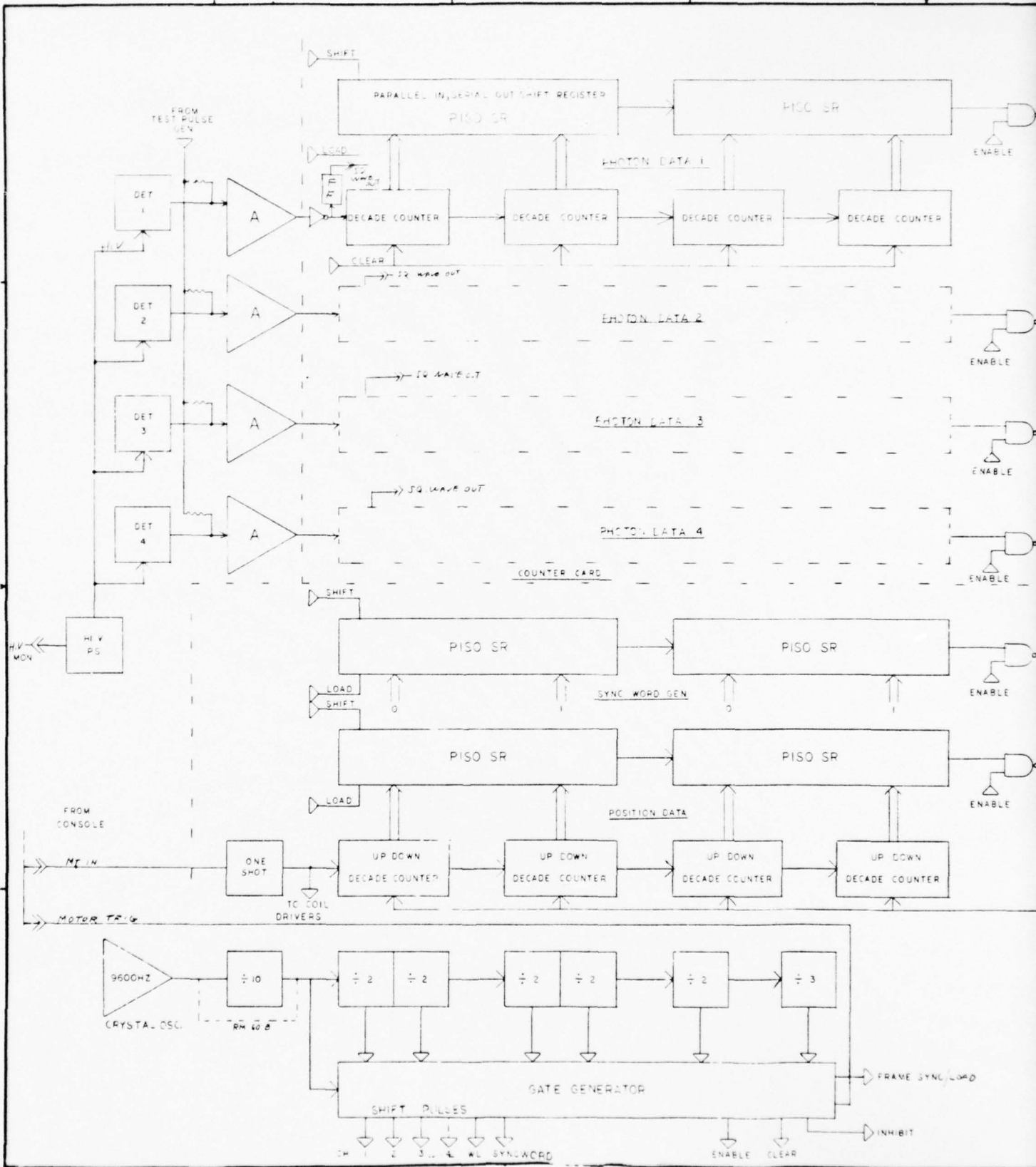

ZONE		LTR		REVISIONS		DATE	APPROVED

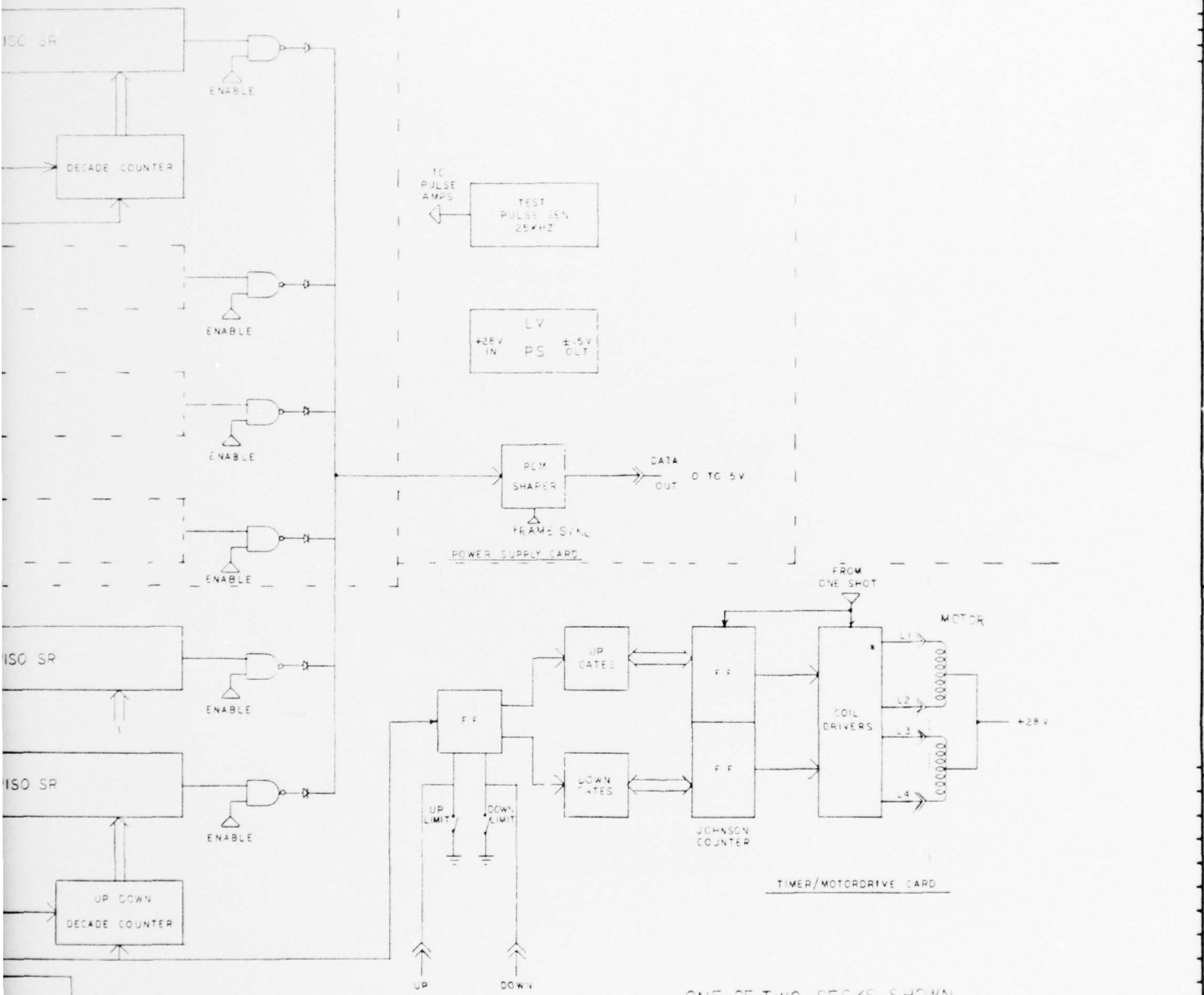

ONE OF TWO DECKS SHOWN

QTY	ITEM NO.	PART NO.	DESCRIPTION	CODE IDENT
LIST OF MATERIAL				
UNLESS OTHERWISE SPECIFIED			Tri-Con Associates	
TOLERANCES			DRAWN CHECKED ISSUED	
.00 ±			MECHANICAL	
.000 ±			ELECTRICAL	
ANGLES ±			PHOTO-OPTICAL	
✓ FINISHED SURFACE ROUGHNESS			STRUCTURAL	
CENTERS PERMISSIBLE			WEIGHTS	
DIMENSIONS IN INCHES AND APPLY AFTER PROCESSING			PROJ APPD	
NEXT ASSY	USED ON	APPROVED	SIZE	CODE IDENT NO.
APPLICATION			D	521
			SCALE	WT
				SHEET

2

The wavelength-scanner position was counted in four decade counters on the motor drive readout cards, transferred to a 16-bit shift register, and shifted out as word two.

The sync word (1110101011001011) was generated on the timer card and was shifted out as word one of the PCM frame.

The six PCM words were combined, and processed on the PS/test/output card to give a nominal 5 volt signal to the FM/FM telemetry deck. This card also contained a test oscillator which, when enabled by the GSE console, generated 25000 pulses/second to check the operation of the pulse amplifiers and counters. A DC-to-DC regulated power supply, also on this card, changed the battery 28 volts to +13 volts and -13 volts needed by the pulse amplifiers and integrated circuits.

The logic circuits for driving the four-position stepping motor were included with the scanner position circuits on the motor drive/timer card.

The timer card contained, in addition to the sync word generator, the PCM clock oscillator and logic circuits to generate the necessary sync pulses, shift pulses, load,

inhibit, and counter reset signals. The clock oscillator was crystal controlled to .01 percent in frequency.

As shown in the timing diagram, the transfer and reset counter signals occur during the first half of the first word of the PCM frame. The photon counters were inhibited during the whole first word and thus accumulated counts during five-sixths of the frame or 83.3 milliseconds.

The high voltage power supply operated from the 28-volt battery and produced 3000 volts. The output voltage was filtered and applied to the anodes of the four detectors. A resistor divider was used to supply 400 volts to the throat terminals of the detectors. Also, a tap at approximately 4 volts was used for a voltage monitor.

The schematics of the printed circuit cards are given in Figures 11, 12, and 13.

The pulse amplifier schematic is shown in Figure 14. The input reference level is set at 10 millivolts. Output for pulses larger than 10 millivolts are 4-volt pulses which are counted by the counter for that channel located on the counter card in the electronics box.

REVISIONS			
ZONE	LTR	DESCRIPTION	DATE

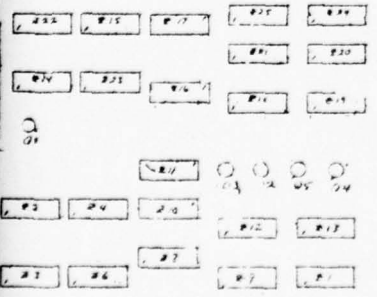
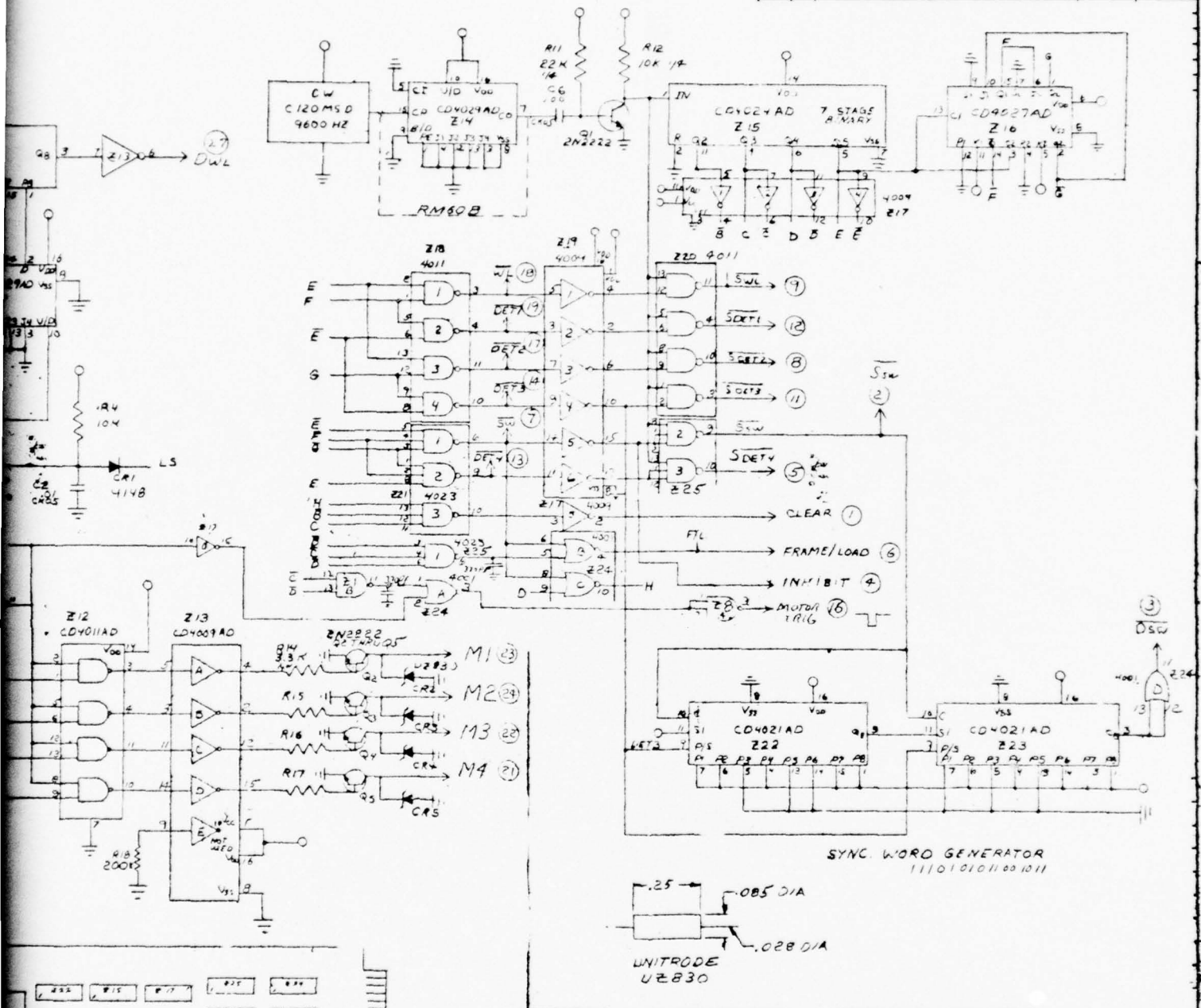

QTY	ITEM NO.	PART NO.	DESCRIPTION	LOGE IDE. #
LIST OF MATERIAL				
UNLESS OTHERWISE SPECIFIED			CONTRACT NO. 7-59	
TOLERANCES			DRAWN CHECKED ISSUED	
.00 ±			MECHANICAL	
.000 ±			ELECTRICAL	
ANGLES ±			PHOTO-OPTICAL	
✓ FINISHED SURFACE ROUGHNESS			STRUCTURAL	
CENTERS PERMISSIBLE			WEIGHTS	
DIMENSIONS IN INCHES AND APPLY AFTER PROCESSING			PRJG APPD	
NEXT ASSY USED ON APPLICATION			APPROVED	
			Tri-Con Associates	
			SCHEMATIC MOTOR DRIVE/TIMER RM 59 (1-59-4)	
			SIZE D	
			COOE IDENT NO. 743	
			SHEET	

41 Figure 11. Motor Drive/Timer RM-59

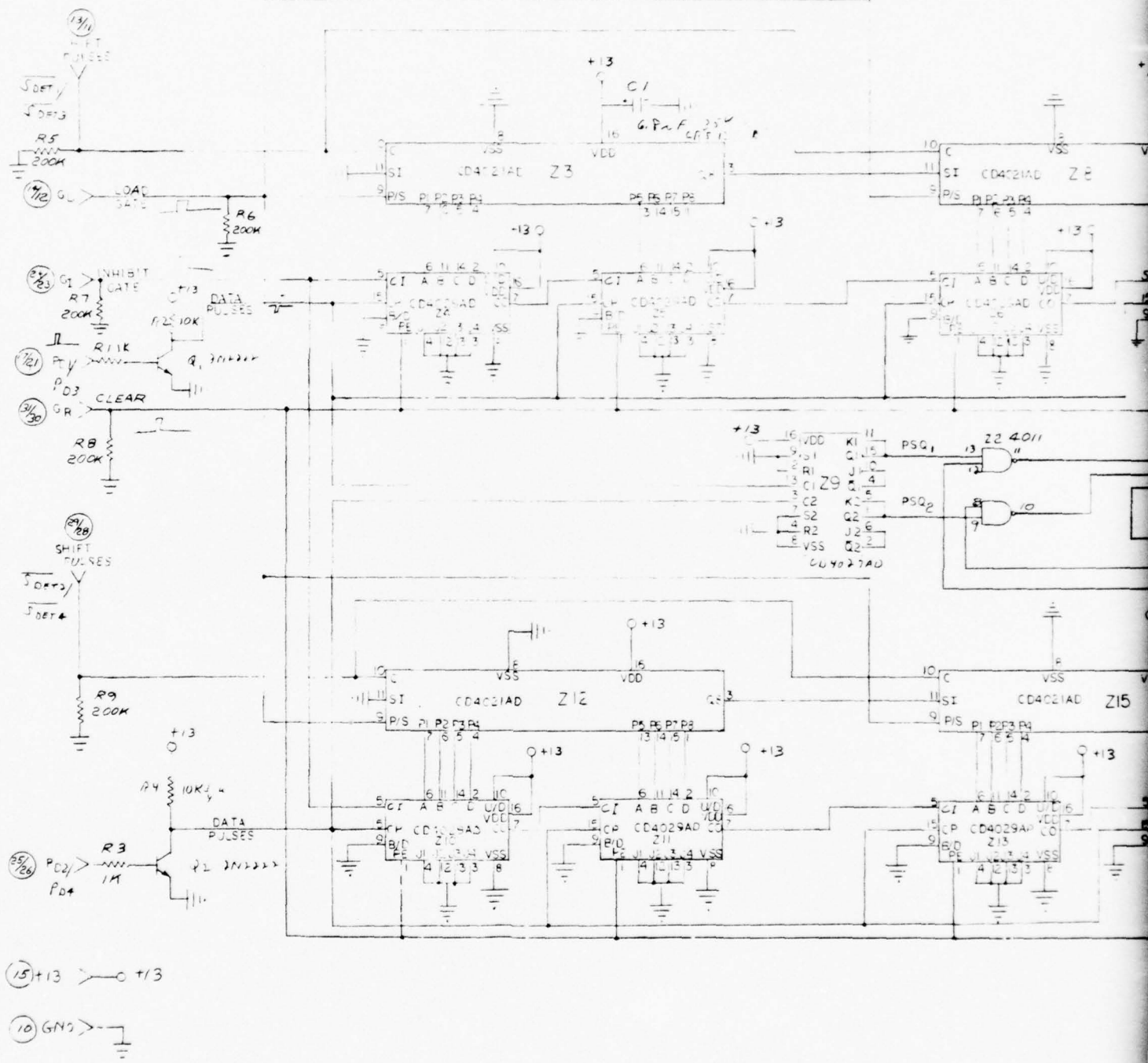

ZONE LTR		REVISIONS	DATE	APPROVED

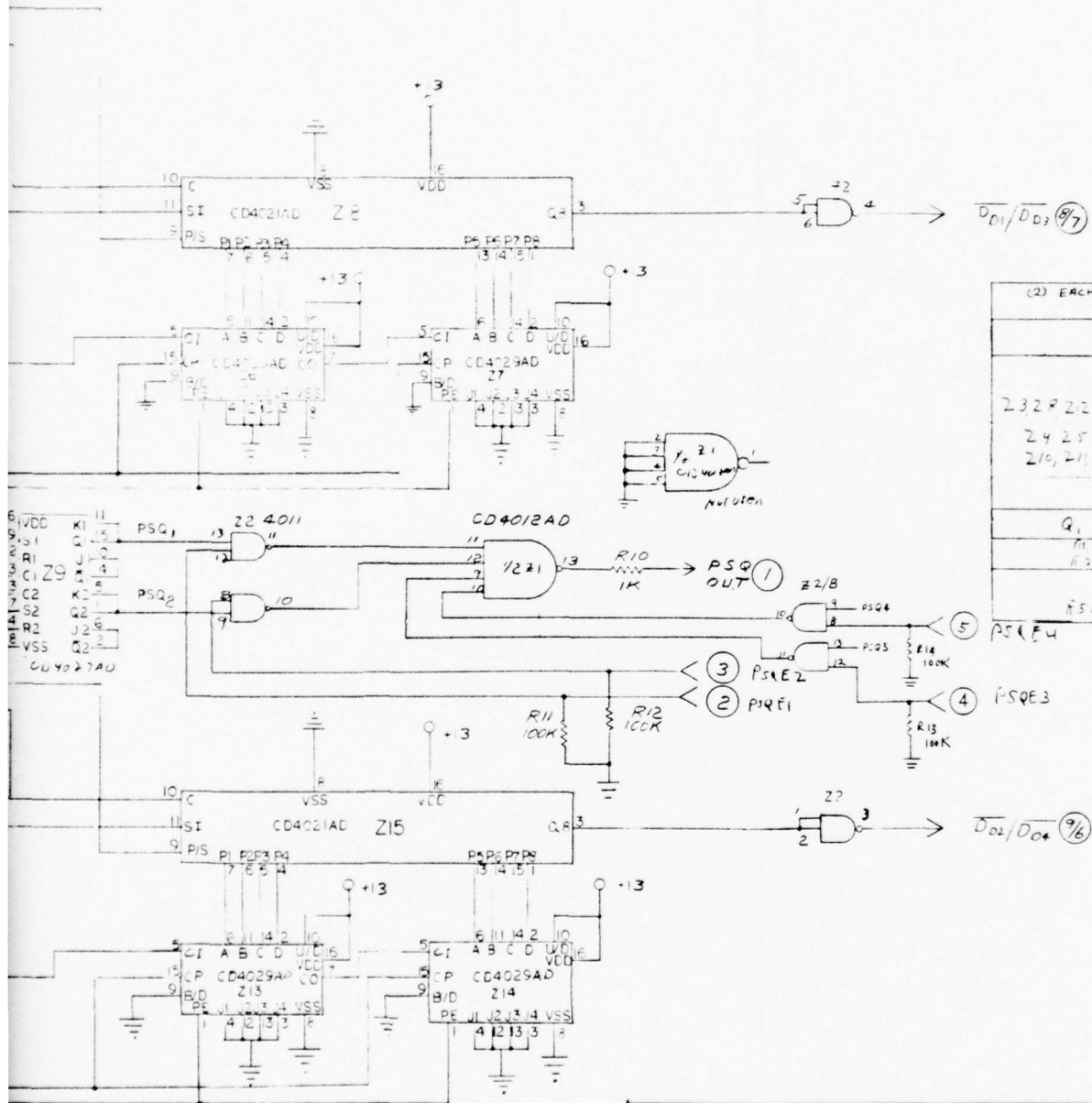

(2) EACH REQUIRED EXCEPT Z1 (0) EACH		
Z1	CD4012AD	14P4
Z2	CD4011A	14P4
Z3, Z4, Z5, Z6, Z7, Z8, Z9, Z10, Z11, Z12, Z13, Z14, Z15, Z16, Z17, Z18, Z19, Z20, Z21, Z22, Z23, Z24, Z25, Z26, Z27, Z28, Z29, Z30, Z31, Z32, Z33, Z34, Z35, Z36, Z37, Z38, Z39, Z40, Z41, Z42, Z43, Z44, Z45, Z46, Z47, Z48, Z49, Z50, Z51, Z52, Z53, Z54, Z55, Z56, Z57, Z58, Z59, Z60, Z61, Z62, Z63, Z64, Z65, Z66, Z67, Z68, Z69, Z70, Z71, Z72, Z73, Z74, Z75, Z76, Z77, Z78, Z79, Z80, Z81, Z82, Z83, Z84, Z85, Z86, Z87, Z88, Z89, Z90, Z91, Z92, Z93, Z94, Z95, Z96, Z97, Z98, Z99, Z100	CD4011A	14P4
Z24, Z25, Z26, Z27, Z28, Z29, Z30, Z31, Z32, Z33, Z34, Z35, Z36, Z37, Z38, Z39, Z40, Z41, Z42, Z43, Z44, Z45, Z46, Z47, Z48, Z49, Z50, Z51, Z52, Z53, Z54, Z55, Z56, Z57, Z58, Z59, Z60, Z61, Z62, Z63, Z64, Z65, Z66, Z67, Z68, Z69, Z70, Z71, Z72, Z73, Z74, Z75, Z76, Z77, Z78, Z79, Z80, Z81, Z82, Z83, Z84, Z85, Z86, Z87, Z88, Z89, Z90, Z91, Z92, Z93, Z94, Z95, Z96, Z97, Z98, Z99, Z100	CD4029A	16
Z29	CD4029AD	16
Q1, Q2, Q3, Q4, Q5, Q6, Q7, Q8, Q9, Q10, Q11, Q12, Q13, Q14, Q15, Q16, Q17, Q18, Q19, Q20, Q21, Q22, Q23, Q24, Q25, Q26, Q27, Q28, Q29, Q30, Q31, Q32, Q33, Q34, Q35, Q36, Q37, Q38, Q39, Q40, Q41, Q42, Q43, Q44, Q45, Q46, Q47, Q48, Q49, Q50, Q51, Q52, Q53, Q54, Q55, Q56, Q57, Q58, Q59, Q60, Q61, Q62, Q63, Q64, Q65, Q66, Q67, Q68, Q69, Q70, Q71, Q72, Q73, Q74, Q75, Q76, Q77, Q78, Q79, Q80, Q81, Q82, Q83, Q84, Q85, Q86, Q87, Q88, Q89, Q90, Q91, Q92, Q93, Q94, Q95, Q96, Q97, Q98, Q99, Q100	2N3222	10, 18
R1, R2, R3, R4, R5, R6, R7, R8, R9, R10, R11, R12, R13, R14, R15, R16, R17, R18, R19, R20, R21, R22, R23, R24, R25, R26, R27, R28, R29, R30, R31, R32, R33, R34, R35, R36, R37, R38, R39, R40, R41, R42, R43, R44, R45, R46, R47, R48, R49, R50, R51, R52, R53, R54, R55, R56, R57, R58, R59, R60, R61, R62, R63, R64, R65, R66, R67, R68, R69, R70, R71, R72, R73, R74, R75, R76, R77, R78, R79, R80, R81, R82, R83, R84, R85, R86, R87, R88, R89, R90, R91, R92, R93, R94, R95, R96, R97, R98, R99, R100	10K, 100K	10, 100
C1	CD4029A	16
F1, F2, F3, F4, F5, F6, F7, F8, F9, F10, F11, F12, F13, F14, F15, F16, F17, F18, F19, F20, F21, F22, F23, F24, F25, F26, F27, F28, F29, F30, F31, F32, F33, F34, F35, F36, F37, F38, F39, F40, F41, F42, F43, F44, F45, F46, F47, F48, F49, F50, F51, F52, F53, F54, F55, F56, F57, F58, F59, F60, F61, F62, F63, F64, F65, F66, F67, F68, F69, F70, F71, F72, F73, F74, F75, F76, F77, F78, F79, F80, F81, F82, F83, F84, F85, F86, F87, F88, F89, F90, F91, F92, F93, F94, F95, F96, F97, F98, F99, F100	500K, 100K	500, 100

NOTE: 1) PSQ3 & PSQ4 ARE FROM #9 ON SECTION B
2) 2ND HALF OF R1 NOT USED (T.R. 100K)

QTY	ITEM NO.	PART NO.	DESCRIPTION	CODE IDENT

UNLESS OTHERWISE SPECIFIED			CONTRACT NO.		
TOLERANCES	.00	±	DRAWN	CHECKED	ISSUED
MECHANICAL	.000	±			
ELECTRICAL	ANGLES	±			
PHOTO-OPTICAL					
STRUCTURAL					
WEIGHTS					
PROJ. APPD					
APPROVED					

LIST OF MATERIAL		Tri-Con Associates	
SCHEMATIC			
PHOTO COPY/PRINT			
REGISTER (2 PER CARD)			
RM-53/60			
SIZE	CODE IDENT NO.		
D	555		
SCALE	WT		

43 Figure 12. Photon Counter/Shift Register

ZONE	DATE	DESCRIPTION	APPROVED

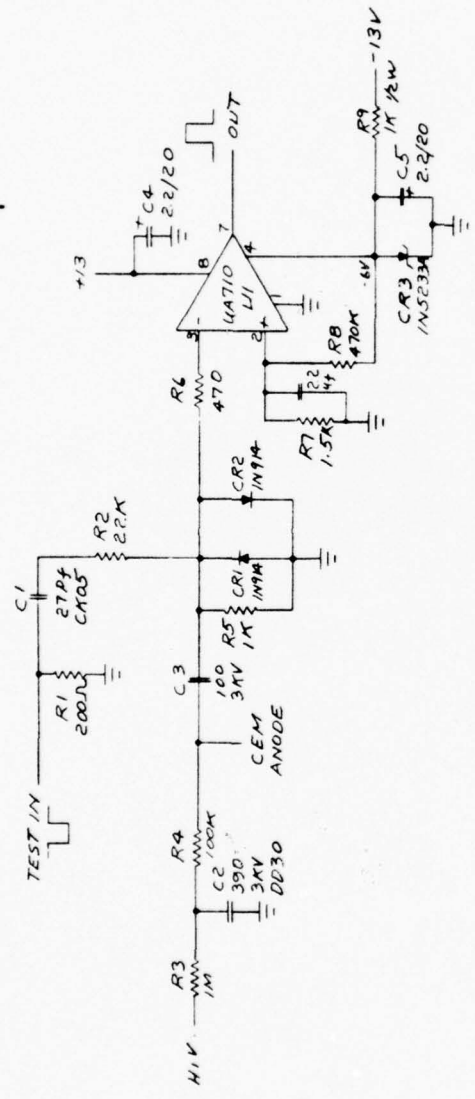

ALL RESISTORS 1/4W UNLESS NOTED

QTY	ITEM NO.	PART NO.	DESCRIPTION	CODE IDENT
LIST OF MATERIAL				
UNLESS OTHERWISE SPECIFIED		CONTRACT NO.	C-725	
TOLERANCES		DRAWN	CHECKED	ISSUED
.00	±	MECHANICAL		
.000	±	ELECTRICAL		
ANGLES	±	PHOTO OPTICAL		
✓	FINISHED	STRUCTURAL		
✓	SURFACE ROUGHNESS	WEIGHTS		
CENTERS PERMISSIBLE		PROJ.	APPRO	
DIMENSIONS IN INCHES		APPROVED		
AND APPLY AFTER PROCESSING				
NEXT ASSY APPLICATION		USED ON		

Tri-Con Associates

PULSE AMP CHANNELTRON RM59/60

SIZE CODE IDENT NO. **C** SCALE **1:1** SHEET **C-589**

Figure 14. Pulse Amp Channeltron

3.9.4 Commutator

The commutator combined onto one channel the monitor voltages of both instruments and the instrument battery. The commutated signal was transmitted on sub-carrier IRIG channel 16.

The sixteen segments were assigned as follows:

<u>Segment</u>	<u>Signal</u>
1,2	Ground
3	+2.5 volt Cal.
4,5	+5.0 volt Cal.
6	Top deck H_1V
7	Top deck +13V
8	Top deck -13V
9	Bottom deck H_1V
10	Bottom deck +13V
11	Bottom deck -13V
12	Battery
13	Spare
14	Spare
15	Spare
16	Spare

A schematic of the commutator is shown in Figure 15. A unijunction oscillator drives a 7-stage binary. The last 4 stages drive a 4 to 16 line decoder. The 16 sequential outputs enable 16 bilateral switches made up of 4 quads. The commutator operates directly from the instrument battery and performs correctly if the battery voltage is more than 18 volts.

3.10 Ground Support Equipment for RM-59 and RM-60

3.10.1 General Discussion

A GSE console was designed and built for use with both the RM-59 and RM-60 instruments. It was used to operate the instruments during acceptance and environmental test, calibration, integration, and in the field prior to launch. The console was also used to decode PCM photon count and wavelength data from both real time TM signals and flight magnetic tapes for quick look data reduction.

The panel is an "inverted pan" configuration which allowed cable connectors to be located on the sides. The raised panel has room below it for electronics and power supplies. Patch cables are carried inside the cover. The case dimensions are 33 cm by 46 cm by 18 cm high. The weight was 11.5 Kg. A photograph is shown in Figure 16.

Four power supplies are mounted to the bottom of the case. One of these supplies 28-volt power to the instrument with separate control of both low voltage and high voltage.

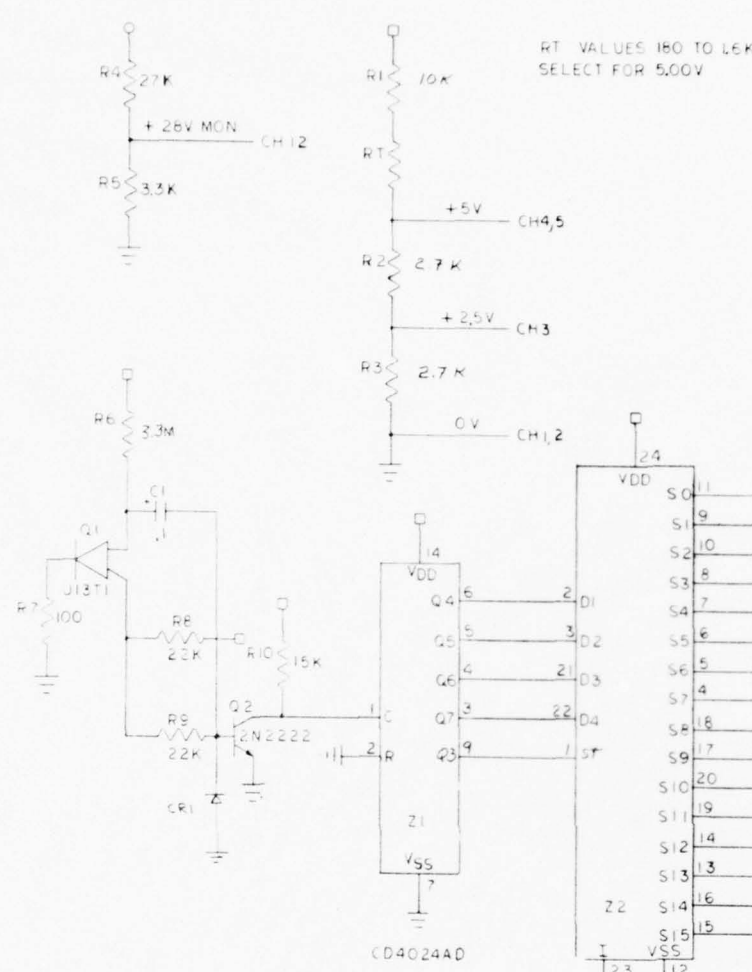

RT VALUES 180 TO 1.6K
SELECT FOR 5.00V

- KEY -
- — +28
 - — +13
 - |— GND
 - |— C4 14F
 - * — PNE5C

CANNON DAM15 P

1	2	3	4	5	6	7	8	9	10	11	12	13	14	15
			CH4	CH7	CH8	CH9	CH10	CH11		CH3	CH4	CH5	CH5	CH5
			HIV1	-13 #1	-13 #1	HIV2	-13 #2	-13 #2		PHI	PHR	TEMP1	TEMP1	TEMP1
														CH5

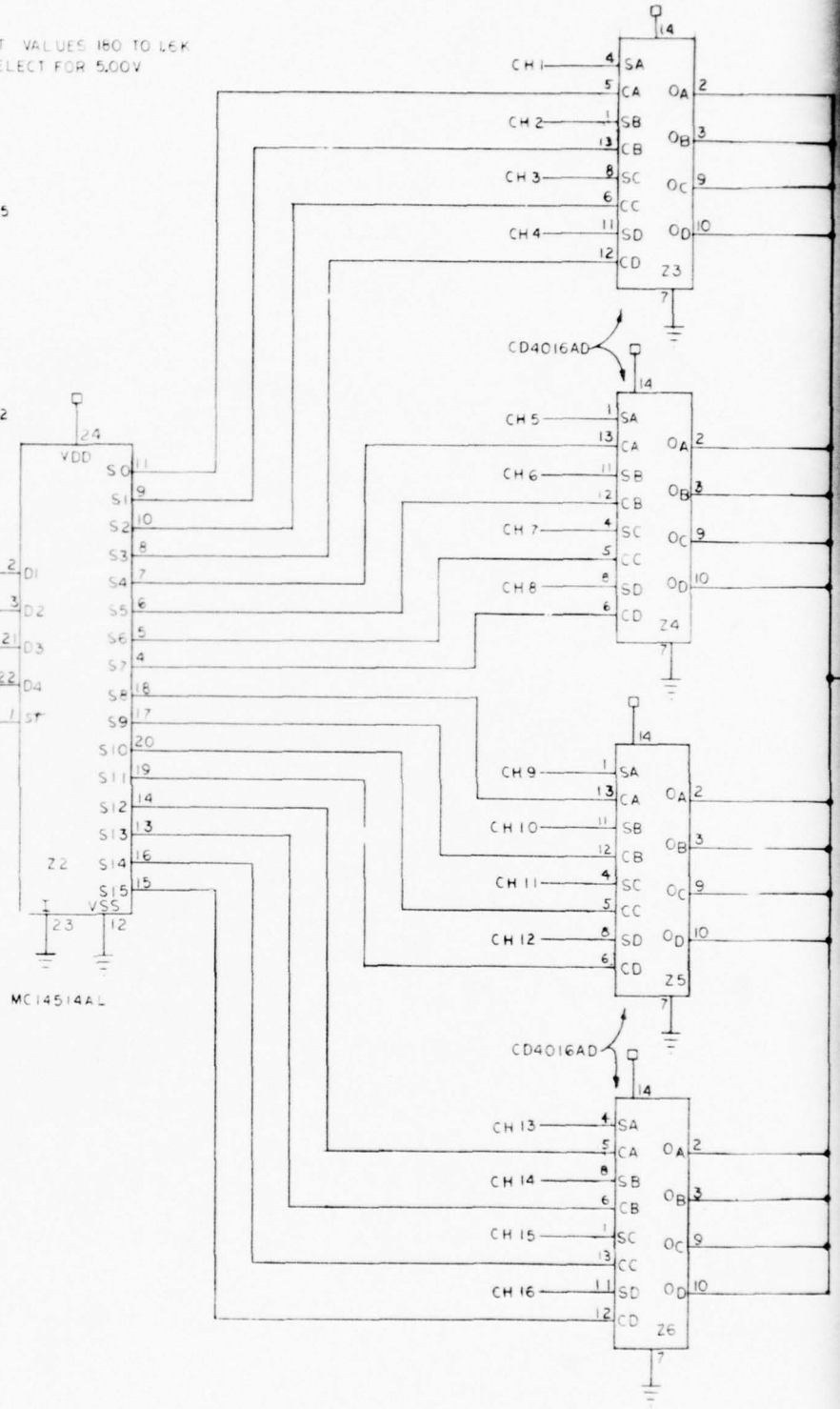

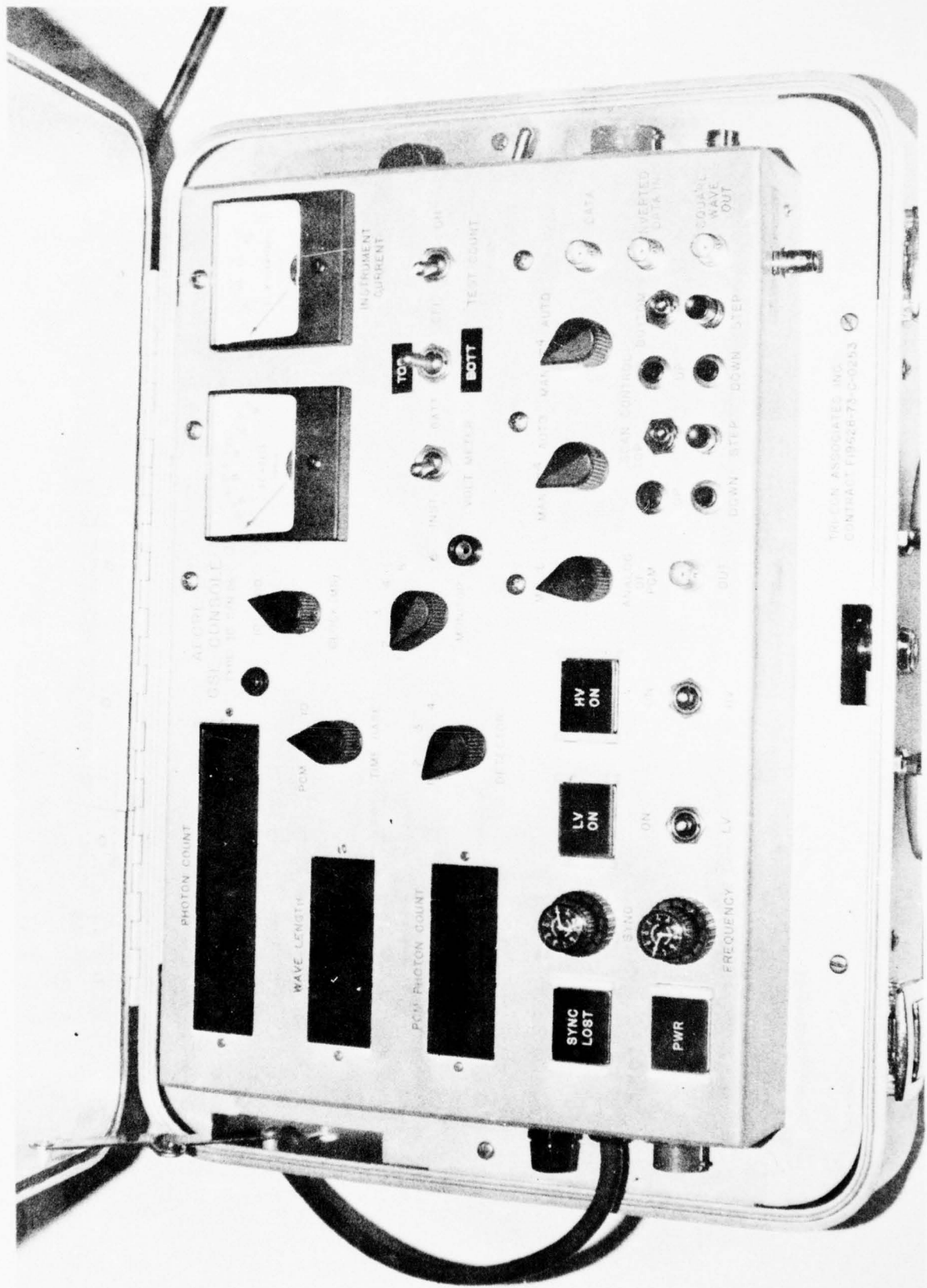

Figure 16. Rocket Spectrometer 59/60 GSE Console

A blower draws in air through the bottom of the case to cool the power supplies and electronics since the case must dissipate about 50 watts.

The electronics were contained on five printed circuit cards in a card rack fastened to the underside of the panel.

3.10.2 Technical Description

A block diagram of the console is given in Figure 17. A timing diagram is given in Figure 18.

The logic was contained on five printed circuit cards designated timer, data decode photon, data decode wavelength, time base, and printer drive.

The timer card contained the clock oscillator and logic to generate the sample pulses required by the data decoding cards. A schematic is given in Figure 19.

Since one deck of instrument RS-60 operates at 100 steps per second while the other deck and both decks of RS-59 operate at 10 steps per second, the console clock oscillator runs at the frequency required for the faster stepping deck and its output is counted down by a factor of 10 when the console is used with the other decks. Its mode is controlled by a front panel switch.

The data decoding cards sampled the PCM data and stored the respective data word in registers to operate the front panel displays, the printer drive card, and the digital to analog converter. A schematic of the cards is given in Figure 20.

The time base card generated the 1-second and 10-second time bases for the 7-digit decode scaler, also contained on the card. This is illustrated in Figure 21.

The BCD information used to drive the displays was converted on the printer drive card from 0 volts and +5 volts for 0 and 1, respectively, to 0 volts and -6 volts required by the printer. A schematic is given in Figure 22.

The photon count BCD information was converted to an analog voltage by an Analog Devices, Inc. digital-to-analog converter Model DAC-12QZ. Three BCD digits were converted to a 10-volt full scale output with a linearity error of \pm the least significant bit. The analog output was useful for producing an intensity versus wavelength plot from magnetic tape of the flight data.

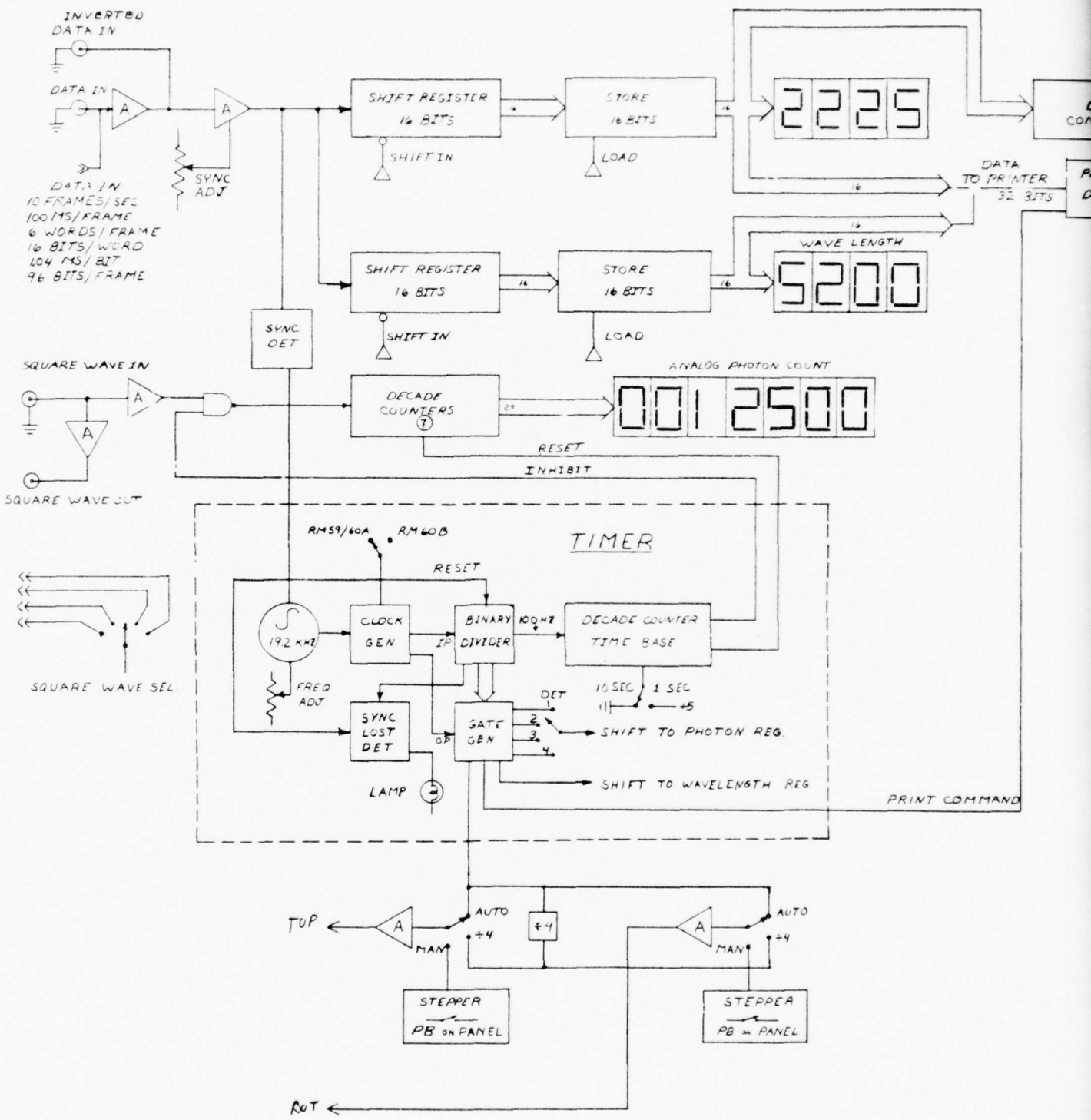

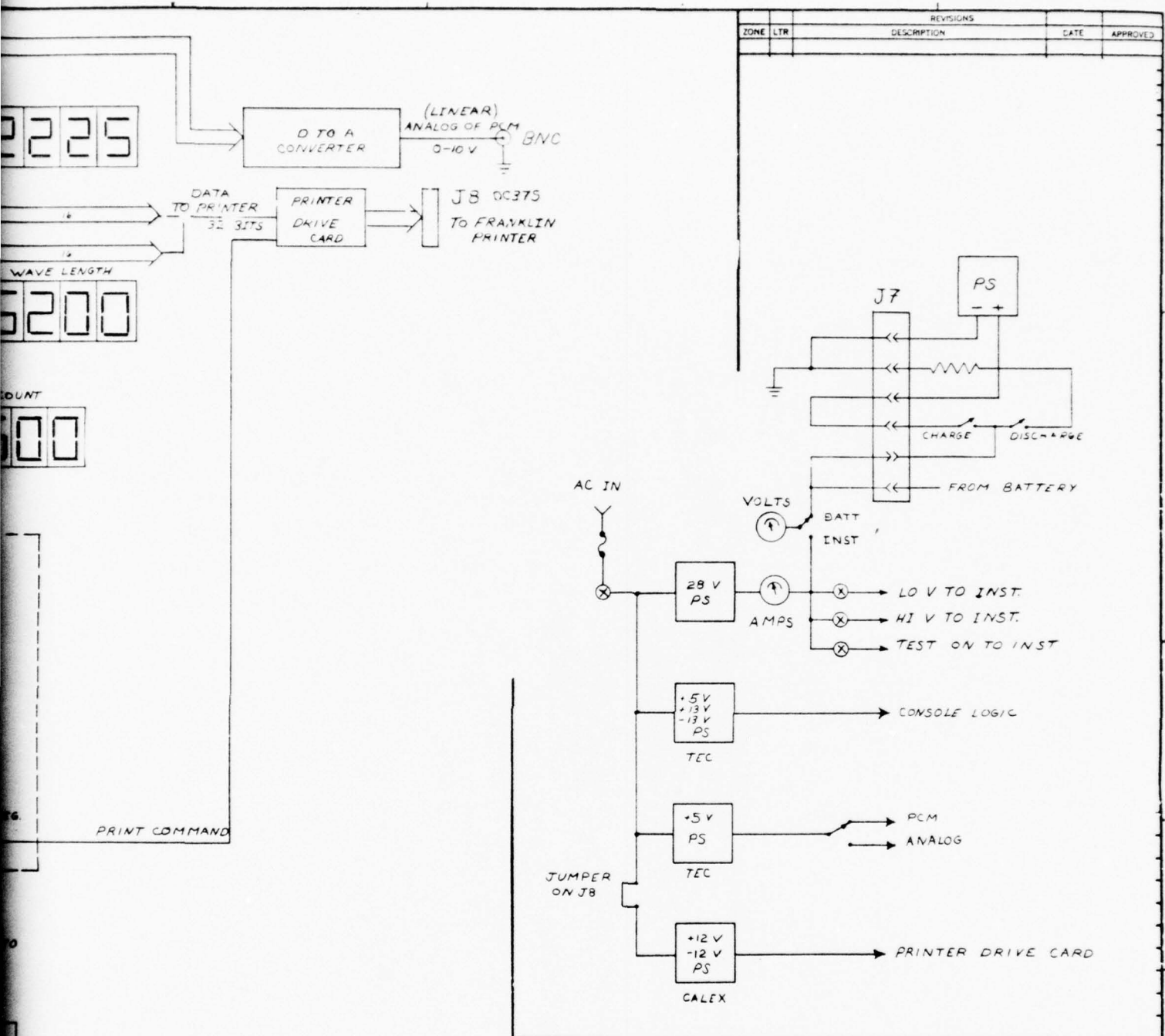

ZONE		LTR		REVISIONS	DATE	APPROVED
				DESCRIPTION		

QTY	ITEM NO.	PART NO.	DESCRIPTION	CODE IDENT
LIST OF MATERIAL				
UNLESS OTHERWISE SPECIFIED			CONTRACT NO. 0125	Tri-Con Associates BLOCK DIAGRAM CONSOLE RM-59/60 SIZE CODE IDENT NO. D 524
TOLERANCES			DRAWN CHECKED ISSUED	
.00 ±			MECHANICAL	
.000 ±			ELECTRICAL	
ANGLES ±			PHOTO-OPTICAL	
✓ FINISHED SURFACE ROUGHNESS			STRUCTURAL	
CENTERS PERMISSIBLE			WEIGHTS	
NEXT ASSY USED ON			PROJ APPD	
			APPROVED	

Figure 17. Block Diagram Console RM-59/60

192 KHZ
OSC

100/10 MS

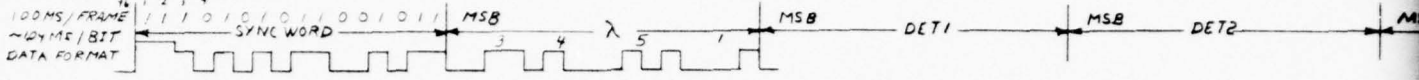
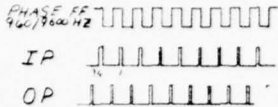
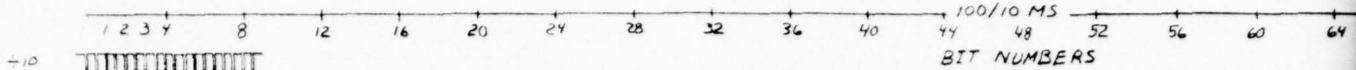

DATA SYNC
TIMER RESET

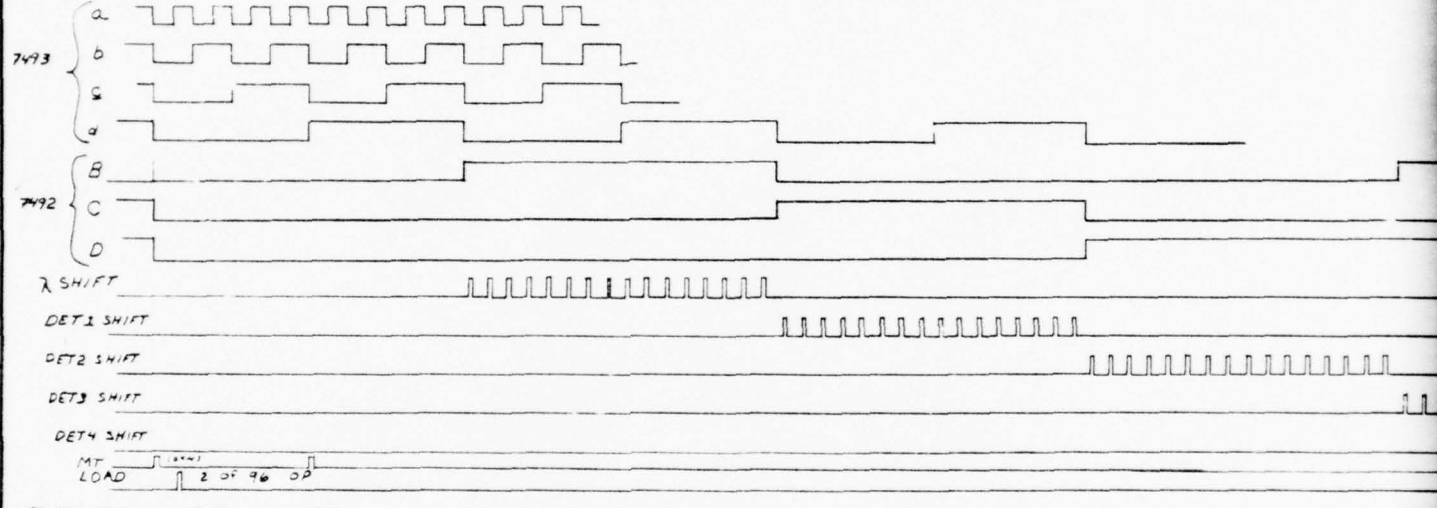

PRINT COMMAND 3 + 4 OF 96

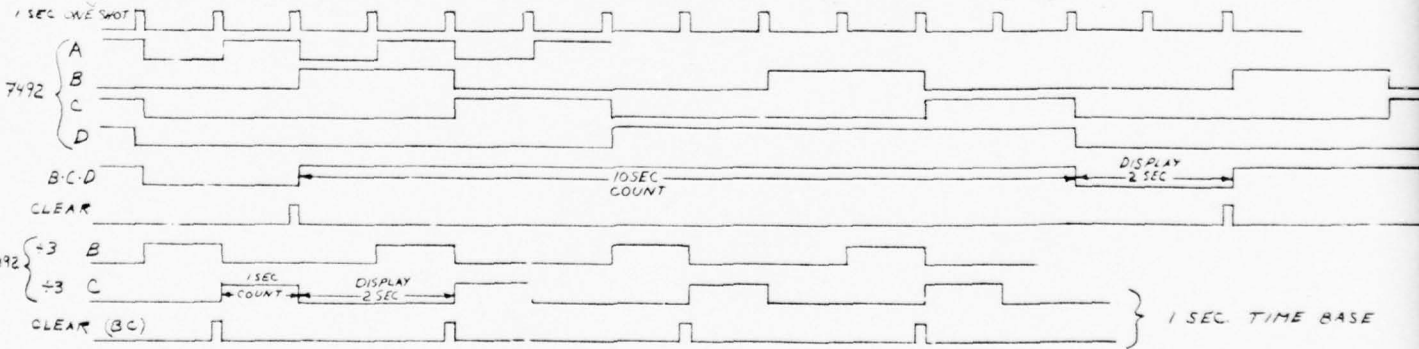

ZONE		REVISIONS		DATE	APPROVED
LTR		DESCRIPTION			

MS
48 52 56 60 64 68 72 76 80 84 88 92 96
NUMBERS

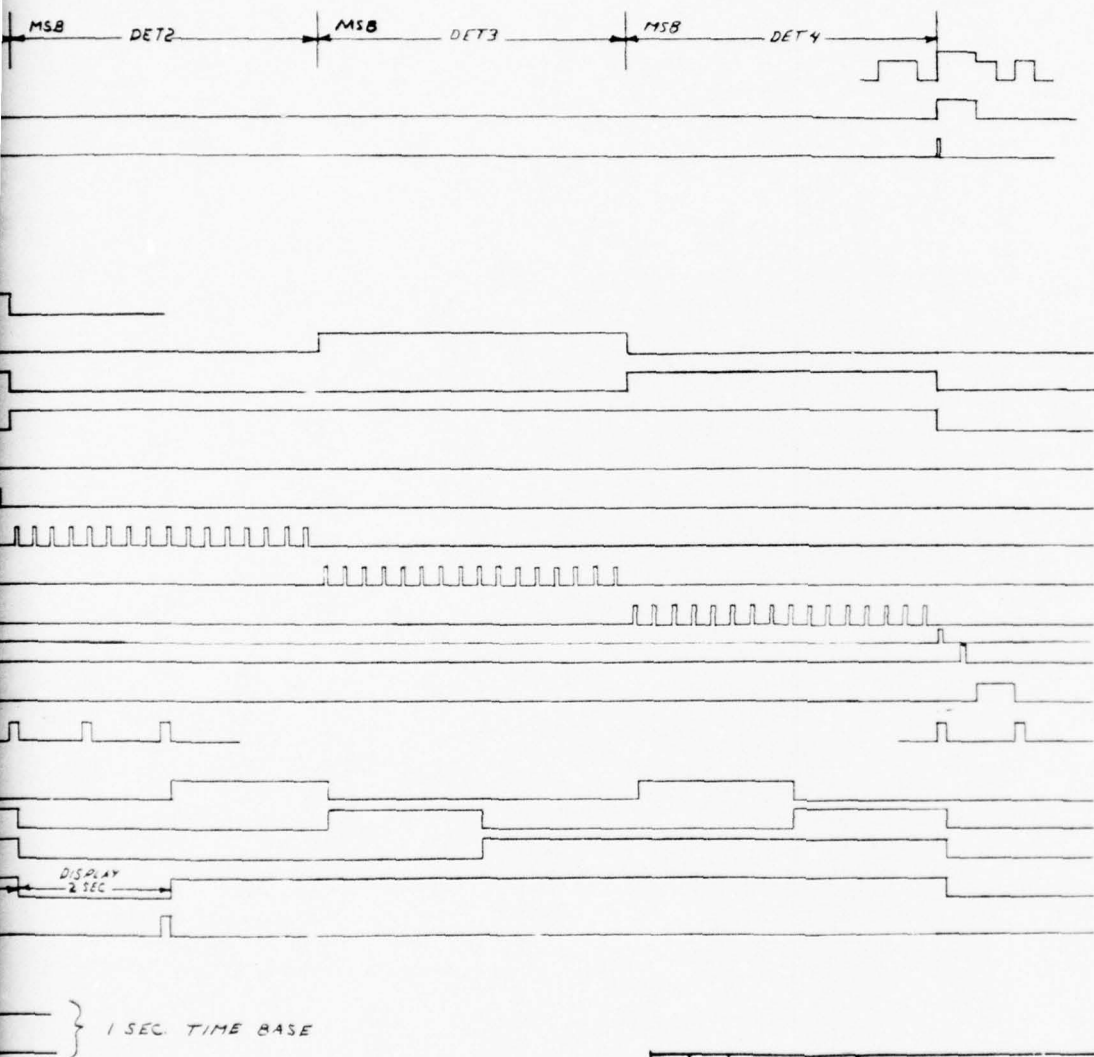

7492

COUNT	B	C	D
0	0	0	0
1	1	0	0
2	0	1	0
3	0	0	1
4	1	0	1
5	0	1	1

QTY	ITEM NO.	PART NO.	DESCRIPTION	CONTRACT NO.	CODE IDENT
			LIST OF MATERIAL		
			Tri-Con Associates		
			TIMING DIAGRAM		
			CONSOLE RM 59/60		
			UNLESS OTHERWISE SPECIFIED	DRAWN	CHECKED
			TOLERANCES		ISSUED
			.00 ±		
			.000 ±		
			ANGLES ±		
			✓ FINISHED SURFACE ROUGHNESS		
			CENTERS PERMISSIBLE		
			DIMENSIONS IN INCHES AND APPLY AFTER PROCESSING		
			NEXT ASSY		
			USED ON		
			APPLICATION		
				WEIGHTS	
				PROJ APPD	
				APPROVED	
				SIZE	CODE IDENT NO.
				D	527

Figure 18. Timing Diagram Console RM-59/60

2

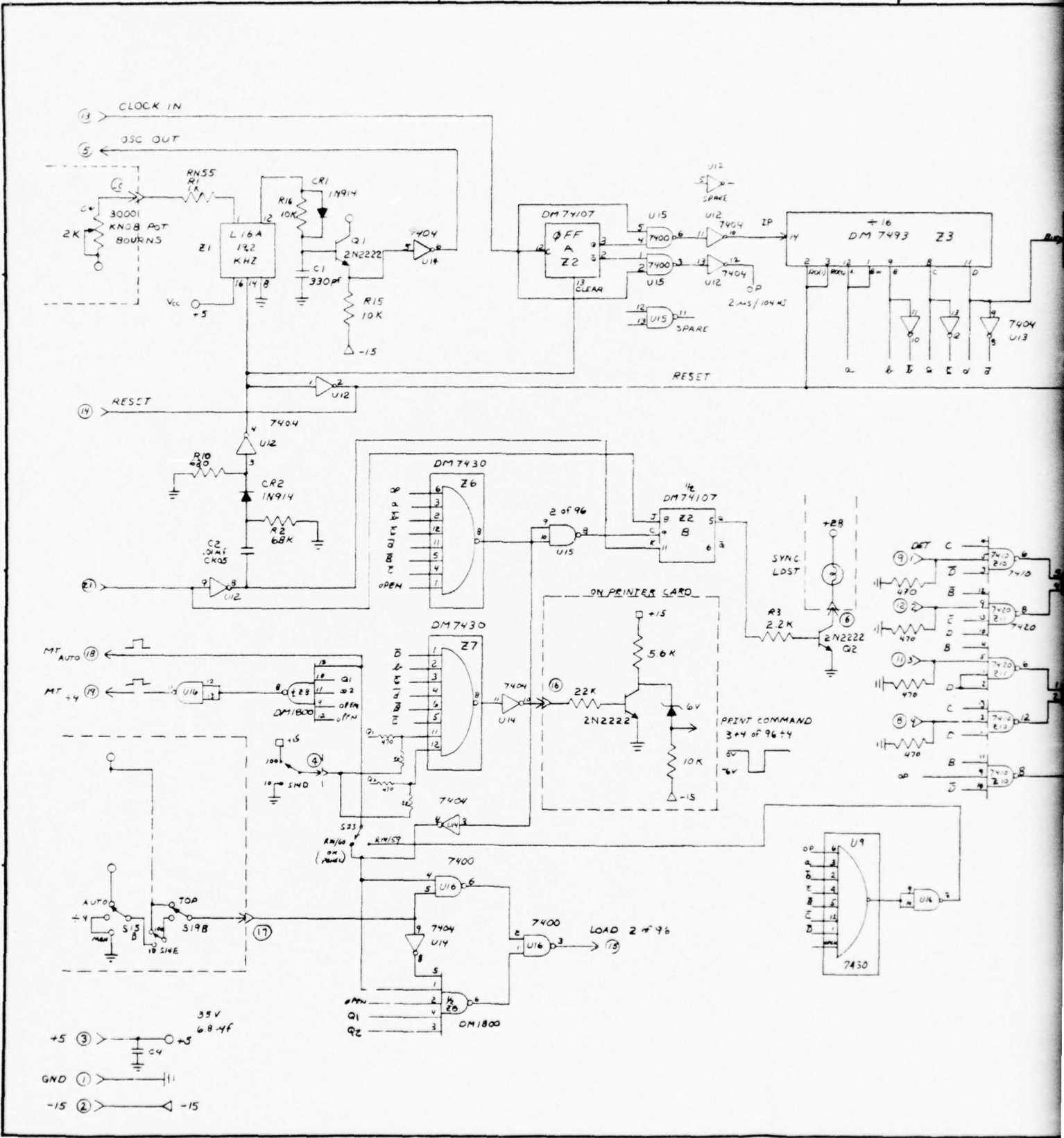

PRECEDING PAGE BLANK-NOT FILMED

ZONE LTR		REVISIONS	DESCRIPTION	DATE	APPROVED
Z1			L16A CW 192 KHZ		1
Z2,Z5			DM74107 N		2
Z3			DM7493 N		1
Z4			DM7492 N		1
Z9,Z6,Z7			DM7430 N		2
Z8			DM1800 N		1
Z10			DM7410 N		1
Z11			DM7420 N		1
U12,U13,U14			DM7404 N		3
U15,U16,U18			DM7400 N		3
R1			1000 Ω RN55C		1
R2			6.8 K		1
R3			2.2 K		1
R10			680 Ω		1
R11,R12,R13,R14			470 Ω		4
R15,R16			10 K		2
U1,QE			2N2222		2
CR1,CR2			1N914		2
C1			330 pF		1
C2			01 μF CK25		1
C4			6.8 μF 35V		2

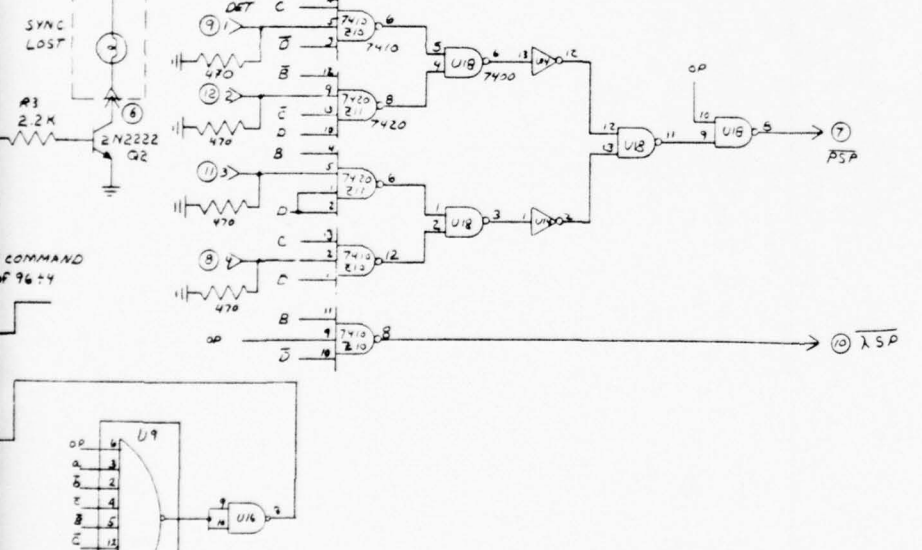
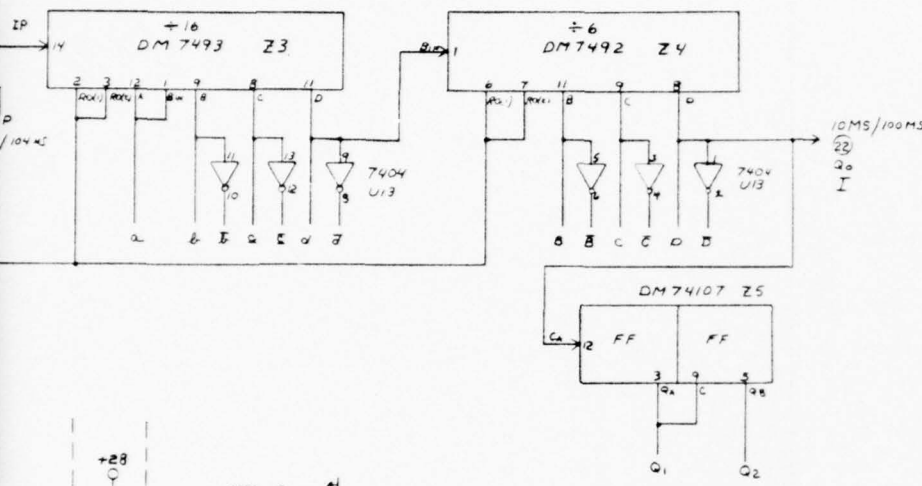

- 1 GND
- 2 -15V
- 3 +5V
- 4 $1/104$
- 5 OSC OUT
- 6 SYNC LOST
- 7 \overline{RSP}
- 8 DET4
- 9 DET1
- 10 \overline{XSP}
- 11 DET3
- 12 DET2
- 13 CLOCK IN
- 14 RESET
- 15 LOAD
- 16 BIT 3,4
- 17 S6 B
- 18 MT AUTO
- 19 MT +4
- 20 FREQ
- 21 DATA SYNC
- 22 G0

P5
AWAY FROM PANEL

QTY	ITEM NO.	PART NO.	DESCRIPTION	CODE IDENT
LIST OF MATERIAL				
UNLESS OTHERWISE SPECIFIED		CONTRACT NO. C-25		
TOLERANCES		DRAWN CHECKED ISSUED		
.00 ±		MECHANICAL		
.000 ±		ELECTRICAL		
ANGLES ±		PHOTO OPTICAL		
✓ FINISHED SURFACE ROUGHNESS		STRUCTURAL		
CENTERS PERMISSIBLE		WEIGHTS		
DIMENSIONS IN INCHES AND APPLY AFTER PROCESSING		PROJ. APPD		
NEXT ASSY USED ON APPLICATION		APPROVED		
		SIZE CODE IDENT NO.		
		D		560
		SCALE		1/8" = 1"

Tri-Con Associates

TIMER CONSOLE
RM 59/60

Figure 19. Timer Console III

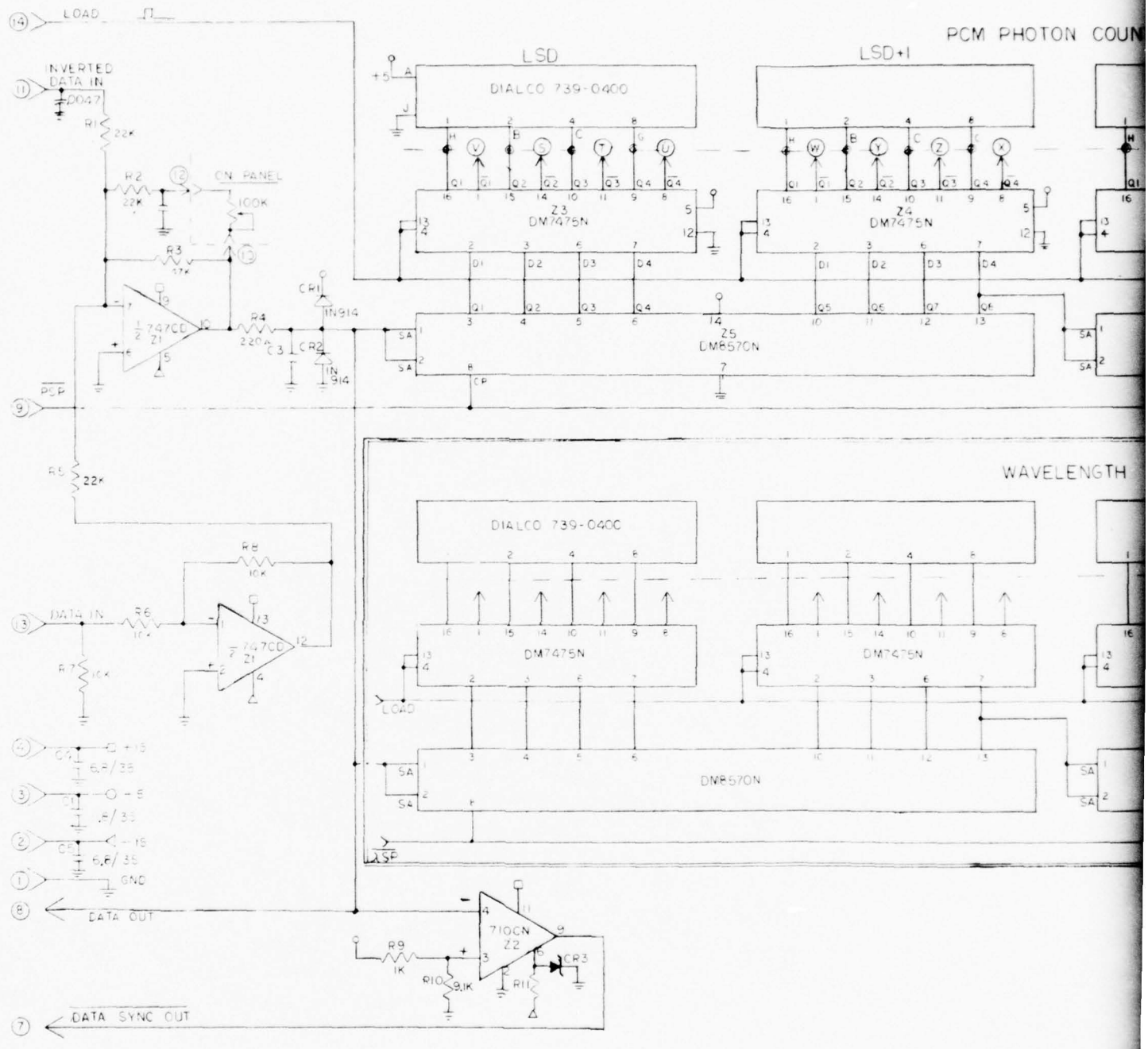

REVISIONS				
ZONE	LTR	DESCRIPTION	DATE	APPROVED

PCM PHOTON COUNT

LSD+1

LSD+2

MSD

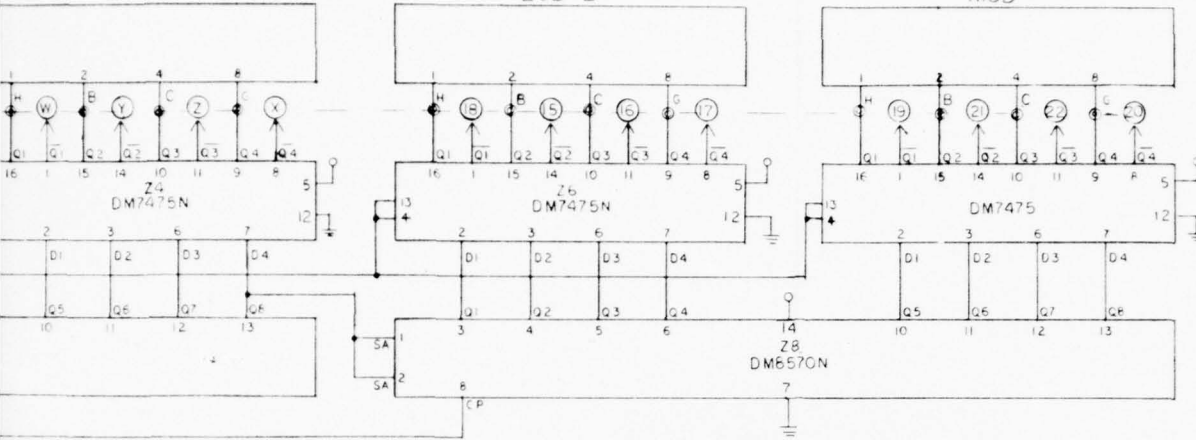

WAVELENGTH

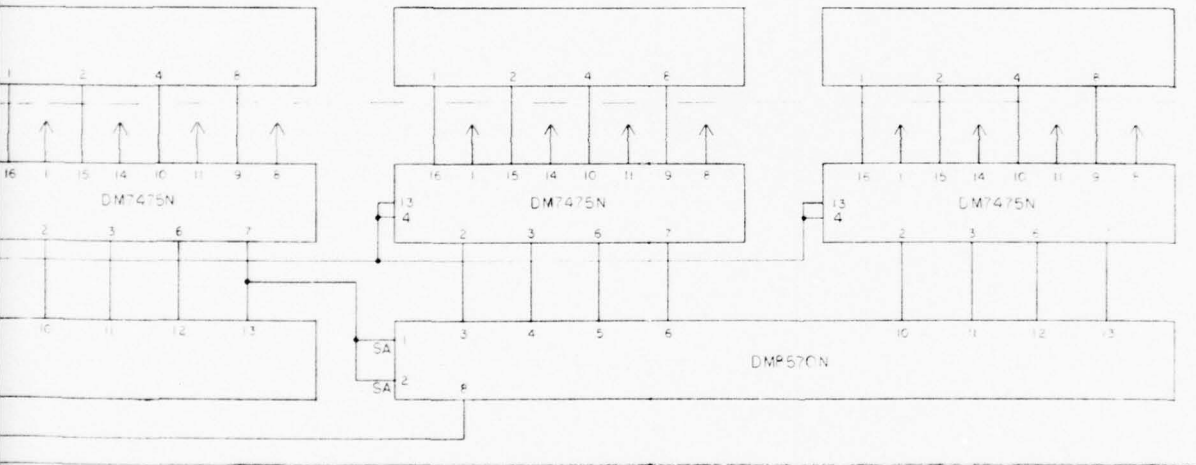

QTY	ITEM NO.	PART NO.	DESCRIPTION	CODE IDENT
LIST OF MATERIAL				
UNLESS OTHERWISE SPECIFIED			CONTRACT NO. 115	Tri-Con Associates DATA DECODE/DISPLAY CONSOLE RM-58-I, II RM 59/50 SIZE CODE IDENT NO. 238 SCALE WT BMEET
TOLERANCES			DRAWN CHECKED ISSUED	
.00 ±			MECHANICAL	
.000 ±			ELECTRICAL	
ANGLES ±			PHOTO-OPTICAL	
✓ FINISHED SURFACE ROUGHNESS			STRUCTURAL	
CENTERS PERMISSIBLE			WEIGHTS	
DIMENSIONS IN INCHES AND APPLY AFTER PROCESSING			PROJ APPD	
APPROVED				
NEXT ASSY USED ON APPLICATION				

Figure 20. Data Decode/ Display Console

2

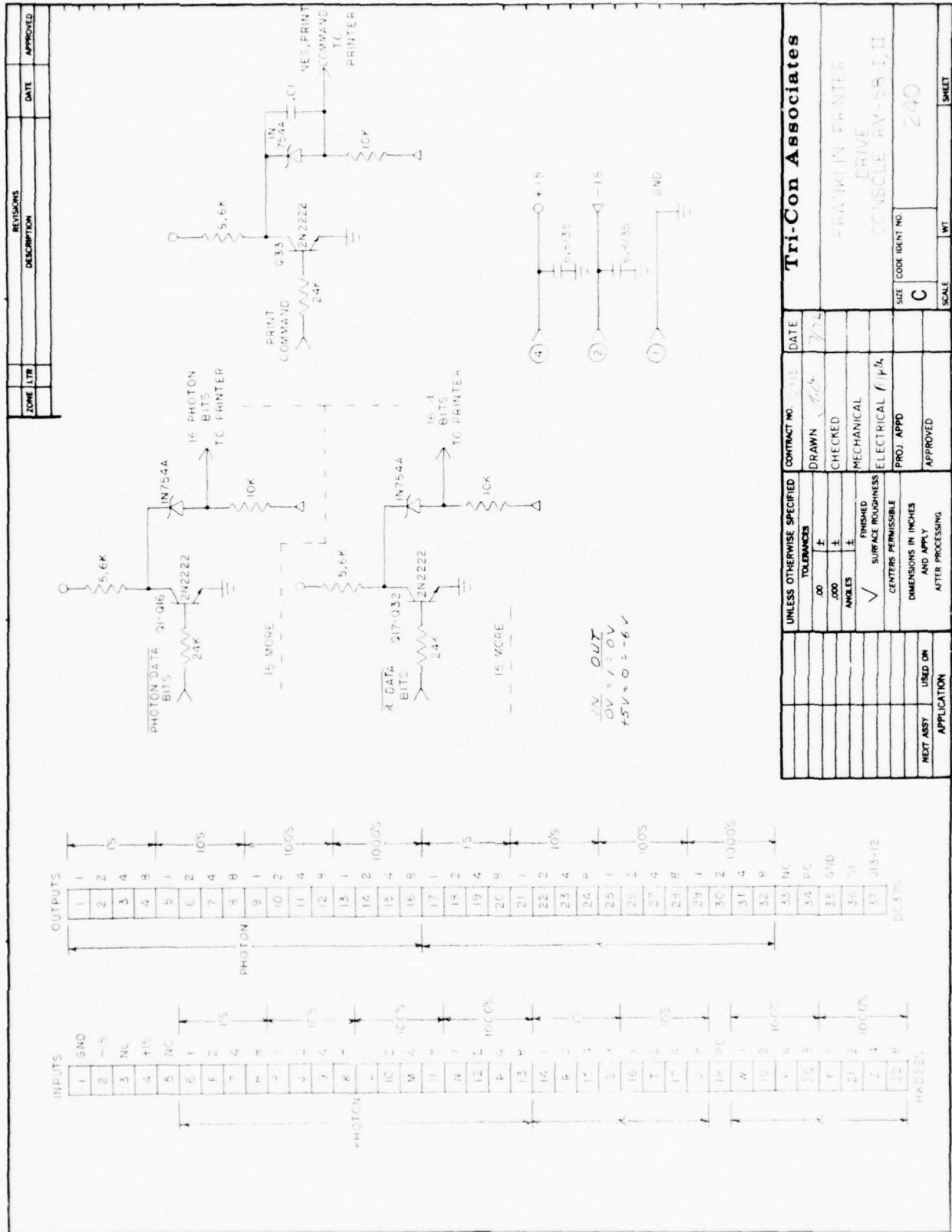

ZONE	REV	DESCRIPTION	DATE	APPROVED

UNLESS OTHERWISE SPECIFIED		CONTRACT NO.	DATE
TOLERANCES			7-72
∅	F	DRAWN	
.000	±	CHECKED	
ANGLES	±	MECHANICAL	
✓	ENHANCED	ELECTRICAL	1/4
	SURFACE ROUGHNESS	PROJ APPD	
	CENTERS PERMISSIBLE	APPROVED	
	DIMENSIONS IN INCHES		
	AND APPLY		
	AFTER PROCESSING		
MET ASSY	USED OR		
	APPLICATION		

Tri-Con Associates	
FRANKLIN PRINTER	
DRIVE	
CONSOLE RM-58 I, II	
SIZE CODE IDENT NO.	240
SCALE	
WT	
SHEET	

Figure 22. Franklin Printer Drive Console RM-58-I, II

3.10.3 Readouts/Controls/Operation

For bench operation and calibration, the console was connected to the instrument by the test harness. In this configuration, power was supplied to the instrument from the console 28-volt supply, was controlled by the low voltage (LV) and high voltage (HV) switches, and monitored by the front panel meters. The PCM data from the instrument were decoded by the electronics in the console. This data consisted of four digit decimal numbers representing photon counts from each detector and a four-digit number representing wavelength scanner position. Photon count from the detector selected by the DETECTOR switch was displayed by the lighted readout labeled PCM PHOTON COUNT. The wavelength scanner position was displayed on the lighted readout labeled WAVELENGTH.

In order to sample and decode the PCM signal, the console clock must be synchronized both in phase and frequency with the PCM frame. The sync control adjusts the amplitude of the PCM data signal to match the frame-sync detector threshold. Improper adjustment was indicated by the SYNC LOST lamp. When the lamp was off, the console clock was being locked in phase with the PCM data frame at the start of each frame. The frequency of the console clock was adjusted to match the PCM bit rate

by the FREQUENCY control. Proper adjustment was achieved when the correct test count was displayed on the PCM PHOTON count readout. The test count generator in the instrument was enabled by 28 volts controlled by the TEST COUNT toggle switch on the console panel. The correct count for RM-59 and RM-60 (bottom deck) was 2083 (25000 pulses per second counted for 83.33 milliseconds). The correct count for RM-60 (top deck) was 0229 (25000 pulses per second counted for 9.167 milliseconds).

With the test harness connected to the test connector on the instrument, the scanner in the instrument was controlled by the console. (In flight, the scanner was stepped when its stepping logic was triggered by a pulse generated in the flight timer electronics.) The console generated and controlled separate trigger pulses. With the SCAN CONTROL switch on AUTO, the pulses occurred at the flight stepping or frame rate of 10 per second for RM-59 and the bottom deck of RM-60 and 100 per second on the top deck. With the scan control on $\div 4$, the scan was stepped every fourth frame on RM-59 and RM-60 (bottom deck) but photon count was displayed and printed out on the Franklin printer for every frame. On RM-60 (top deck) with the scan control on $\div 4$, the scan was stepped every fourth frame and the photon count was displayed and printed out every fourth frame or 25 lines per second

which the printer can handle. With the SCAN CONTROL switch on MAN (manual), the scanner was stepped by the STEP push button switch. The direction of scan was controlled by the UP and DOWN push button switches.

To assist in calibration, the console contained a 7-digit decade scaler which measured the frequency of the square wave output of the instrument. The count accumulated in either 1 or 10 seconds, as selected by the TIME BASE switch, was displayed on the readout labeled PHOTON COUNT. The number displayed was one-half the actual photon count. The lamp to the right of the display indicated when the counter gate was open. The display time was two seconds in both the 1 second and 10 second count modes. The SQUARE WAVE BNC connector provided a buffered output square wave signal that could be counted by an external counter, if desired. The time base for the 1 second and 10 second counting intervals was derived from the console clock which was synchronized with the instrument crystal clock and thus was accurate to ± 0.01 percent.

An analog voltage proportional to either the three most or three least decimal digits of the PCM PHOTON COUNT was brought out on the BNC connector labeled OUT. The most (M) or least (L) significant digits were selected by the ANALOG OF PCM switch.

The console could be used to display PCM photon count and wavelength as decoded from a PCM signal derived from a real time telemetry signal or magnetic tape playback. In this case the data were usually inverted in sense and could be handled by using the INVERTED DATA BNC input connector. The connector labeled DATA was either input or output since it was in parallel with the data wire on the console instrument connector.

The console drove a Franklin Printer to print out wavelength and photon count on the same line. Since the printer has a maximum print rate of 30 lines per second, the PRINT position of the SCAN CONTROL switch was used. This reduced the stepping rate of the instrument by 4 if it were being controlled by the console and also held the displayed data and printer data for 4 frames giving an apparent frame rate of 25 ($100 \div 4$) frames per second or printer lines per second.

3.10.4 Performance

The consoles were used to operate the instruments during calibration. They were used at Ball Brothers Research Corporation for the integration and performance tests. At the launch site the instruments in the tower were operated and set in the proper mode for launch by the consoles located in the blockhouse.

Immediately after launch, the consoles were used to produce quick look data reduction at the site telemetry station.

3.11 Testing and Calibration

Prior to instrument calibration, which was done by AFGL personnel at their facility, various tests were conducted by the contractor before acceptance. Reports and/or data were supplied on the following performances:

3.11.1 Detector Tests

A well-defined counting plateau for count rates of 10^5 counts per second was established for each CEM by illuminating it with EUV radiation. This was done before potting with a test amplifier and repeated after potting with its own flight amplifier. Background count rates when operated at plateau conditions without illumination were obtained in both instances. Data for the above were supplied to the contractor with delivery of the instrument.

3.11.2 Acceptance Tests

Prior to acceptance of the instrument, it underwent specific tests at AFGL by Government personnel. These tests are enumerated in a report filed by Comstock & Wescott with the Contract Monitor titled, "Test and Acceptance Plan for Rocket Spectrometer No. 59" dated 15 February 1974.

The instrument, prior to acceptance, was also subjected to a series of vibration tests at AFGL.

3.12 Field Support Services

Provision of support during integration with the pointing control and also during launch of the instrument were called for in this contract. This included a trip to Ball Brothers Research Corporation in Boulder, Colorado, and also a trip to Wallops Island, Virginia. Support also included the maintenance and operation of a Government-owned field vacuum system (including a helium leak detector).

This instrument was launched (with the nose cone evacuated) at 1545 E.D.T. on 29 June 1974, aboard an Aerobee 170 rocket from Wallops Island, Virginia. Useful data were received on seven of the eight detectors; no quantitative data were obtained from the detector monitoring the 1206 \AA wavelength. The instrument was recovered from the water after flight and checks then showed that six of the eight detector amplifiers no longer functioned. No definite determination was made on the cause of these malfunctions. Other pertinent information on the launch of this instrument is contained in a letter report dated 15 July 1974 titled, "Letter Report on Instrumentation and Flight of RM-59."

4. ROCKET SPECTROMETER NO. 60

4.1 Introduction

This instrument was a grazing-incidence double-deck spectrometer capable of scanning in either a continuous or a stepping mode while measuring the spectral distribution of the intensity of solar extreme ultraviolet radiation in the wavelength ranges of 55Å to 305Å and 220Å to 1220Å. Each wavelength range was divided into four overlapping bands; and each band was scanned by moving an assembly consisting of an exit slit and a channel electron multiplier (CEM) along the Rowland circle. The four CEM's on each deck were operated simultaneously during laboratory calibration. The inclusion of a more complex entrance aperture than on the previous instrument enabled this unit to study specific plage areas of the sun.

4.2 Instrument Package

The instrument housing was similar to RM-59 and was machined from a similar magnesium alloy casting (AZ-91C). It also followed the design depicted in Figure 1. Table II summarizes the technical characteristics of this instrument.

4.3 Entrance Aperture

An objective of the aperture design for RM-60 was to restrict the instrumental field of view to approximately 2×10^{-6} steradian.

The complete viewing constraints, however, were to limit the instrumental field of view to five arc minutes in the azimuth and five arc minutes in the elevation directions. This objective was easily attained in the elevation direction (parallel to the plane of dispersion) but required the use of a multi-grid, multi-channel collimator in the orthogonal (slit height) direction in order to enhance the throughput of the instrument.

The design of the collimator followed the geometric principles outlined by McGrath and Harwit* in which the value for $(1 - x)$ was chosen as 0.72. This relatively large transmission value was chosen in order to minimize the total slit height and provide an acceptable match with the exit slits at the longest wavelength scanned by the instrument.

A short collimator was originally proposed for this application but was soon increased in length in order to minimize loss of intensity due to Fraunhofer diffraction at the entrance slits of the collimator.

Since the permissible slit width increases directly with an increase in collimator length, whereas the diffraction profile varies inversely with the slit width, it is possible to realize a rapid gain in throughput with modest increases in the collimator length. An additional increase in the width of the collimator entrance grid slits was possible by interpreting the instrumental field of view to mean an unattenuated field of view.

* Applied Optics 8, 837 (1969)

TABLE II

TECHNICAL CHARACTERISTICS OF ROCKET SPECTROMETER NO. 60

	Top Deck	Bottom Deck
Entrance Slit	{.0508 mm (Flight) .127 mm (Calibration)	.025 mm
Grating	1200 ℓ /mm gold replica	300 ℓ /mm gold replica
Exit Slit	{.0508 mm (Flight) .127 mm (Calibration)	.025 mm
Detectors	4 CEM (MgF ₂ coated cones)	4 CEM (MgF ₂ on two shortest wavelengths)
Wavelengths Covered	55 \AA - 310 \AA	220 \AA - 1220 \AA
Steps per Scan	1400	5200
Distance per Step	.06096 mm	.01524 mm
Duration of Scan	140 sec	52 sec
Stepping Rate	10 steps per sec	100 steps per sec
Resolution	0.22 \AA FWHM	0.43 \AA FWHM

This interpretation permitted larger entrance apertures that provided an angular response to a distant point source that showed a flat topped triangular characteristic with a total width at cutoff equivalent to 7.5 arc minutes.

Figure 23 illustrates the basic collimator grid/spacer subassembly while Figure 24 illustrates the collimator support housing and eyeblock mount.

4.4 Grating Mount

Same as in 3.4.

4.5 Gratings

The gratings for RM-60 were also gold coated Bausch & Lomb replicas with the following characteristics:

	<u>Deck A</u>	<u>Deck B</u>
Bausch & Lomb No.	35-52-39-70	35-53-39-30
Ruling	1200 grooves/mm	300 grooves/mm
Ruled Area	32 mm ruled width 24 mm groove length	32 mm ruled width 24 mm groove length
Blaze Wavelength	1160 Angstroms	4650 Angstroms
Blaze Angle	4° 00'	4° 00'
Grating Blank	Both -- 1986 mm radius, fused quartz as in the previous instrument (RM-59).	

4.6 Detectors

The Galileo No. 4500 oval cathode channel electron multiplier was also used in this instrument for

photon detection. Because of the expected lower count rates due to the restricted field of view, a MgF_2 coating was deposited by Acton Research Corporation on the inside of the cone of six of the detectors (those at the shorter wavelengths) to increase the photoelectric yield. The same testing procedures as that described in Section 3.6 were also carried out here.

During the calibration of this instrument at AFGL, one of the detectors failed in a manner similar to that experienced with RM-59. A resistance check of the defective detector from this instrument and the three from RM-59 disclosed an open circuit between the anode and throat of the CEM's. The resistance value when received, tested, potted, and tested again was always about 1.5×10^9 ohms, but when measured after loss of signal would be $> 10^{12}$ ohms. After extensive correspondence with Galileo Electro-Optics, it was determined that they had made some changes in their production process. Prior detectors were constructed as a one-part glass component whereas the detectors used in RM-59 and RM-60 were two-part glass assemblies. The collector caps on the later detectors had to be connected to the inner glass (conductor) by evaporation of a chromium strip.

This strip had opened in the failed units during calibration, rendering the CEM useless. According to Galileo, no repair could be done on the component itself once this occurred. They conclude that a "screening" test by them might have detected the bad ones in the lot if such a test had been applied. All previously used CEM's of the one-part glass were "unscreened" with a

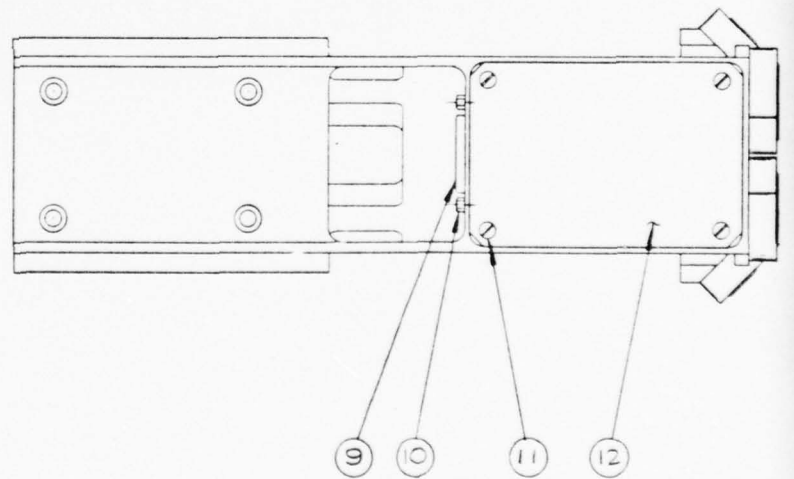
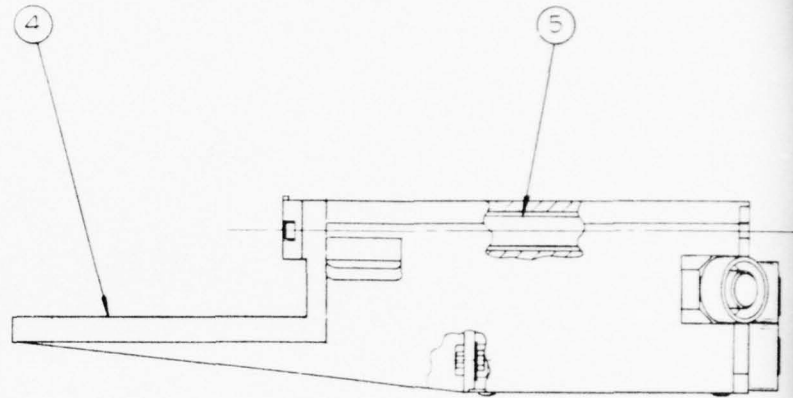
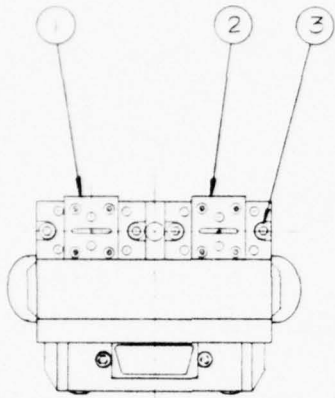

REVISIONS				
ZONE	LTR	DESCRIPTION	DATE	APPROVED

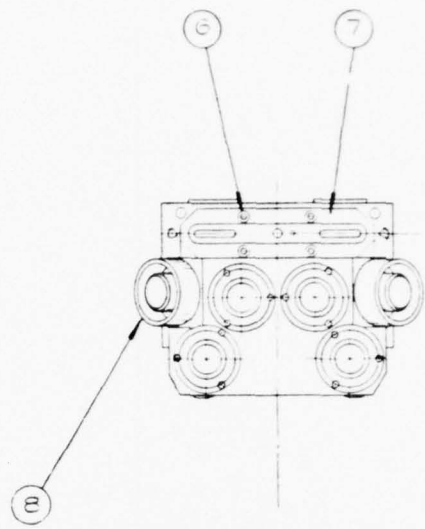
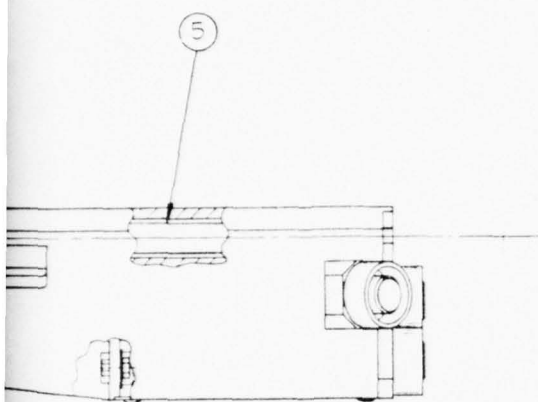

NOTES
1. TO BE INSTALLED BY AERO-JET

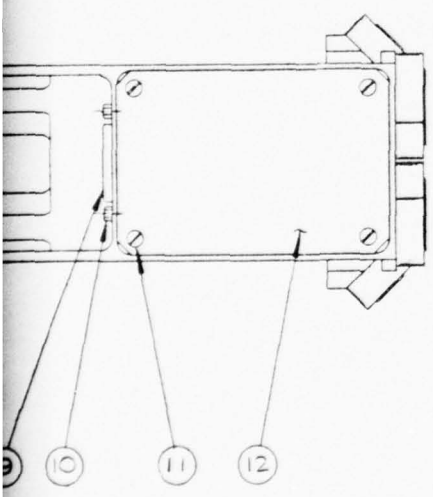

12	COVER	A 2771		1	
11	PAN HD SCREW	"4-40 UNC x 1/4 LG	ST STL	4	
10	SCREW LOCK (FEMALE)	020418-2	ITT CANNON	2	
9	CONNECTOR	0AM-15P	ITT CANNON	1	
8	SENSOR ASSY		SEE NOTE 1	6	
7	POLARIZED APERTURE ASSY	A 2757		1	
6	SOC HD CAP SCREW	"2-56 UNC x 3/8 LG	ST STL	4	
5	SOLAR ALIGNMENT SENSOR ASSY	B 2146		1	
4	COLLIMATOR & EYE BLOCK HOUSING	J 041		1	
3	SOC HD CAP SCREW	"6-32 UNC x 3/8 LG	ST STL	4	
2	INTERNAL ASSEMBLY (SHORT X)	B 2134-1		1	
1	INTERNAL ASSEMBLY (LONG X)	B 2134-2		1	
ITEM	DESCRIPTION	PART OR IDENTIFYING NO.	SPECIFICATION	CODE IDENT NO.	QTY REQD

LIST OF PARTS

UNLESS OTHERWISE SPECIFIED DIMENSIONS ARE IN INCHES SURFACE FINISH		CONTRACT NO. 75-0233	DATE	COMSTOCK & WESCOTT, INC. CAMBRIDGE, MASSACHUSETTS
TOLERANCE DECIMALS ANGLES XX ± 0.15 XXX ± .005 ± 0.15 DO NOT SCALE THIS DRAWING		DRAWN T.W. JAY	3-27-53	
MATERIAL		CHECKED	APPROVED	COLLIMATOR AND EYE BLOCK ASSEMBLY
E 391	10022	APPROVED	10/1/53	SIZE CODE IDENT NO. DRAWING NO.
NEXT ASSY	USED ON	PROTECTIVE FINISH	APPROVED	D 31561 D 812
APPLICATION				SCALE PROJECT NO. SHEET OF

83 — Figure 24. Collimator and Eye Block Assembly

hundred percent success of operation after installation. The fatigue failure rate on the new standard production stock is twenty to thirty percent as now quoted by Galileo.

Future orders will specify a one-part glass assembly with the collector cap epoxied to the output face of the CEM. The orders will also require a full screening according to the following specifications prior to acceptance.

GAIN -

The CEM gain (G_{CEM}) shall be greater than 5×10^7 for an anode voltage (V_A) less than 2700 volts when operating at a count rate of 2000 counts per second throughout the LIFETIME tests.

LIFETIME -

The minimum total accumulated counts shall equal 1×10^9 and shall be sampled at 5×10^8 count intervals. The maximum total accumulated counts shall not exceed 2×10^9 . It is required that V_A (at which $G_{\text{CEM}} = 5 \times 10^7$ at 2 KHz) shall not increase more than 50 volts between two consecutive intervals. Results will be recorded at each interval.

FWHM -

Evaluated at $G_{\text{CEM}} = 5 \times 10^7$ at 2 KHz, the FWHM = 30%. Results will be recorded at each interval.

CHANNEL ELECTRON MULTIPLIER RESISTANCE

(R_{CEM}) -

Over the duration of the LIFETIME tests, R_{CEM} shall not change by more than 10%. Data will be recorded at each interval.

4.7 Wavelength Scanning Subsystem

The wavelength scanning subsystem was similar to that described in Section 3.7 but with the distance between limit switches extended. The scan times for a complete continuous spectrum scan in this instrument were 52 seconds for the 220 \AA to 1220 \AA range and 140 seconds for the 55 \AA to 310 \AA range. The data frame time was 100 milliseconds and 10 milliseconds, respectively.

4.7.1 Take-Up Pulley Assembly

The same as that described in Section 3.7.1.

4.7.2 Drive Assembly

The drive assembly was the same as that described in Section 3.7.2 for the short wavelength deck but a 40:1 gearhead was used in the long wavelength deck of this instrument, resulting in a step increment of .0006 inch (.01524 mm).

4.7.3 Flexible Belt Drive

The same as that described in Section 3.7.3.

4.7.4 Detector Amplifier Carrier Assembly

The same as that described in Section 3.7.4 except that the detectors were equidistantly apart in order to supply overlapping wavelength coverage.

4.8 Optical Alignment

Identical reference surfaces for alignment of gratings, entrance slits, and exit slits were also provided for this instrument as those noted in Section 3.8.

4.9 Electronics for Rocket Spectrometer No. 60

4.9.1 General

The electronic subsystems built for the two decks of RM-60 instrument were similar to those built for RM-59. However, there were differences as required for differing scan rates.

As mentioned in Section 3.9.1, the logic cards of both decks were mounted in the same electronics box.

A timing diagram is given in Figure 9. Note that the scan motor moves only one position per frame instead of two as it did in RM-59. This is possible because less torque is required since the carriage motion is less per frame. The frame was

10 per second on the top deck and 100 per second on the bottom deck. The console, as described in Section 3.10, could operate in either mode.

For flight, the PCM data would have been brought through the interface connector and the bottom deck PCM would modulate IRIG channel H subcarrier oscillator in the S-band telemetry deck which could adequately carry the 104 microsecond PCM bit width. The top deck PCM which operated at one-tenth the rate of the bottom deck could be carried on a narrower band width channel.

4.9.2 Physical Configuration

The physical configuration of RM-60's electronic system was exactly the same as that of RM-59.

4.9.3 Circuit Description

The block diagram of RM-60 electronics was the same as RM-59. See Figure 10.

The top deck motor drive/timer card contains a 12 millisecond "one shot" motor pulse generator and the bottom deck card an 8 millisecond "one shot."

As shown in the timing diagram, the transfer and reset counter signals occur during the first half of the first word of the PCM frame. The photon counter in the top deck was inhibited during the first word of the six word frame or one-sixth of 100 milliseconds. Thus, the accumulate time was 83.3 milliseconds. On the bottom deck the photon counter was inhibited for only one-half of the first PCM word or one-twelfth of the time giving an accumulative time of eleven twelfths of 10 milliseconds or 9.17 milliseconds.

The schematic of the motor drive/timer card is given in Figure 25. Other schematics are the same as those of RM-59.

4.9.4 Commutator

The same type commutator was to be used with RM-60 as with RM-59.

4.10 Testing and Calibration

Prior to actual calibration by AFGL personnel, the detector tests and acceptance tests, as enumerated in Section 3.11, were carried out on this instrument. They are noted in a report filed by Comstock & Wescott with the Contract Monitor titled, "Test and Acceptance Plan for Rocket Spectrometer No. 60," dated 19 July 1974.

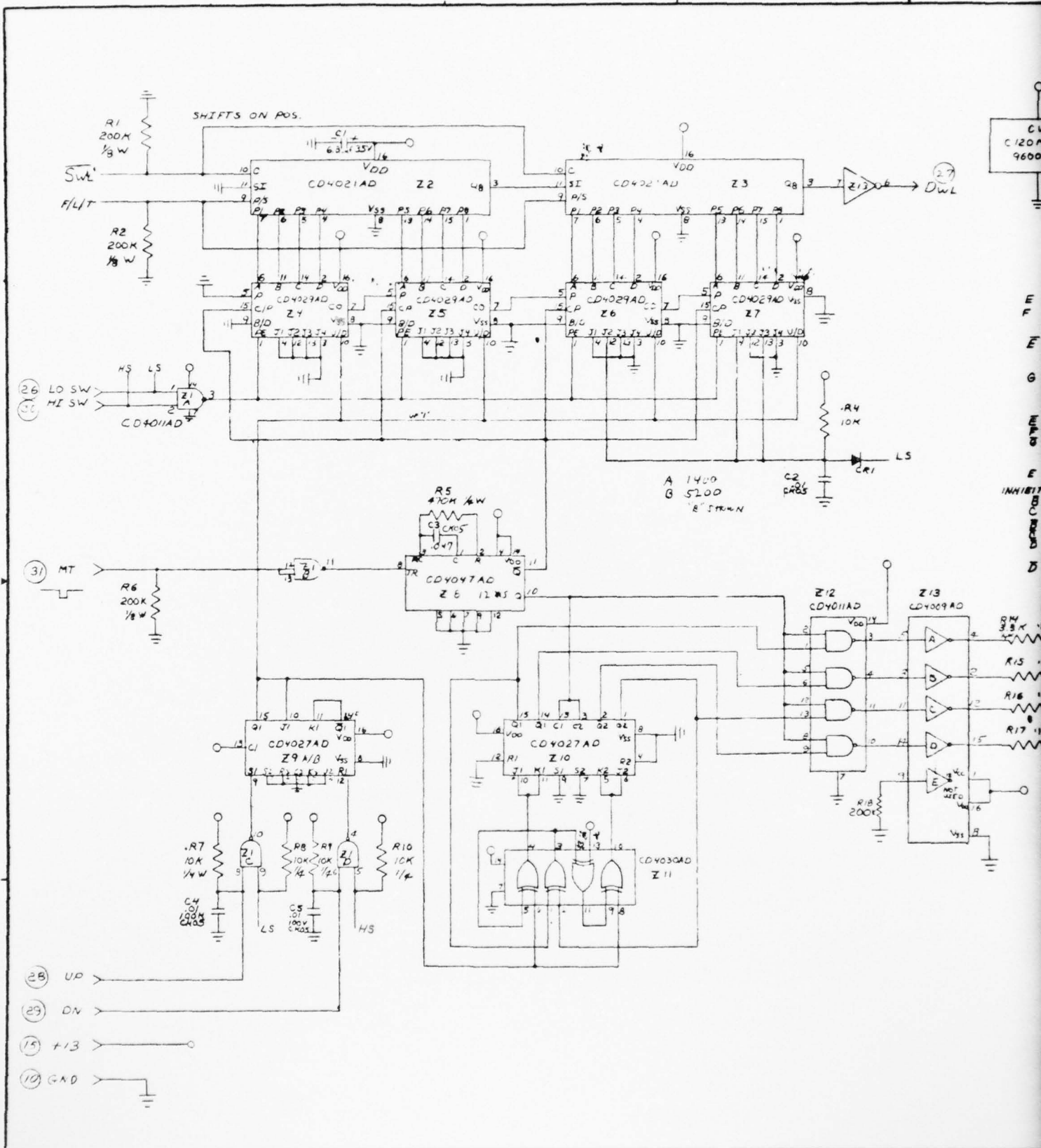

CW
C120M
9600

E
F
G
H
I
J
K
L
M
N
O
P
Q
R
S
T
U
V
W
X
Y
Z

R14
R15
R16
R17
R18
R19
R20
R21

ZONE		REVISIONS		DATE	APPROVES
LTR		DESCRIPTION			

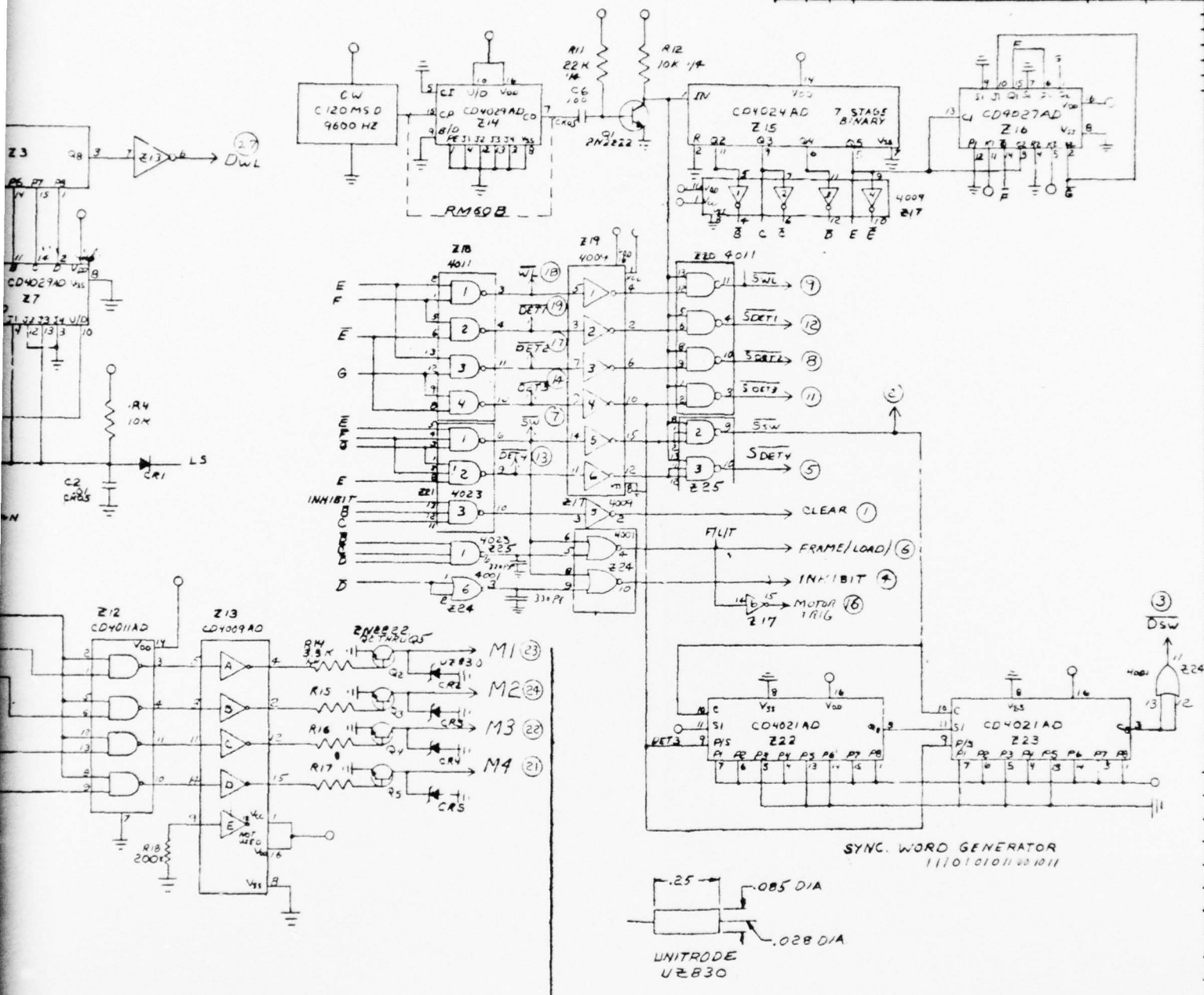

QTY	ITEM NO.	PART NO.	DESCRIPTION	CODE IDENT
			LIST OF MATERIALS	
UNLESS OTHERWISE SPECIFIED			CONTRACT NO. C-25	Tri-Con Associates
TOLERANCES			DRAWN CHECKED ISSUED	
.30 ±			MECHANICAL	SCHEMATIC MOTOR DRIVE/TIMER RM-60
.000 ±			ELECTRICAL	
ANGLES ±			PHOTO-OPTICAL	
✓ FINISHED SURFACE ROUGHNESS			STRUCTURAL	
CENTERS PERMISSIBLE			WEIGHTS	SIZE CODE IDENT NO. D 557
DIMENSIONS IN INCHES AND APPLY AFTER PROCESSING			PROJ APPD	
NEXT ASSY USED ON			APPROVED	
APPLICATION				

Figure 25. Schematic Motor Drive/Timer RM-60

5. ROCKET SPECTROMETER NO. 59-II

5.1 General

The recovered double deck instrument from the Wallops Island launch (RM-59) was redesignated as RM-59-II. The eight (8) CEM detectors were replaced along with eight new pulse amplifiers. Detector tests and acceptance tests were performed as enumerated in Section 3.11. This instrument had the same technical characteristics as that listed in Table I.

Along with the grazing-incidence spectrometer, two Government furnished auxiliary experiments were added to the payload. They were an Electron Spectrometer and a side viewing Photometer for which electronic boards, ground support equipment, and integration services were furnished by the contractor. A description of the components and services supplied is covered in the following sections.

5.2 Electron Spectrometer Electronics

An electronic subsystem was designed and built to energize the government-furnished electron spectrometer detector.

The electronics generated 64 different voltages which were applied in sequence to the detector plates. The electrons collected at each voltage (energy level) were multiplied in a channel electron

multiplier in the detector assembly and the current bursts (each burst representing one electron) were counted in a 4 decade decimal counter (16 bits).

The 16-bit electron count, along with six binary bits (representing each of the 64 detector voltage levels at which the electrons were collected) and a 16-bit sync word comprised the PCM frame. A timing diagram is given in Figure 26. The frame rate was 50 per second. Thus, the electron collection time for each voltage step was 20 milliseconds (actually 15 microseconds less than 20 milliseconds or 19.985 milliseconds).

The detector voltages range from less than a volt to more than 64 volts and the ratio of successive voltages was held to better than one-half of one percent. A table of voltages is given in the test acceptance plan for the electron spectrometer, dated 25 September 1975.

A high voltage power supply and filter card for the electron multiplier was mounted adjacent to the multiplier. The output pulses from the multiplier were amplified in a pulse amplifier and fed to the counter and logic boards which were located in a card rack mounted on the same base plate as the detector itself.

REVISIONS	DATE	APPROVED
DESCRIPTION		
ZONE LTR		

0.117 MS/MIT

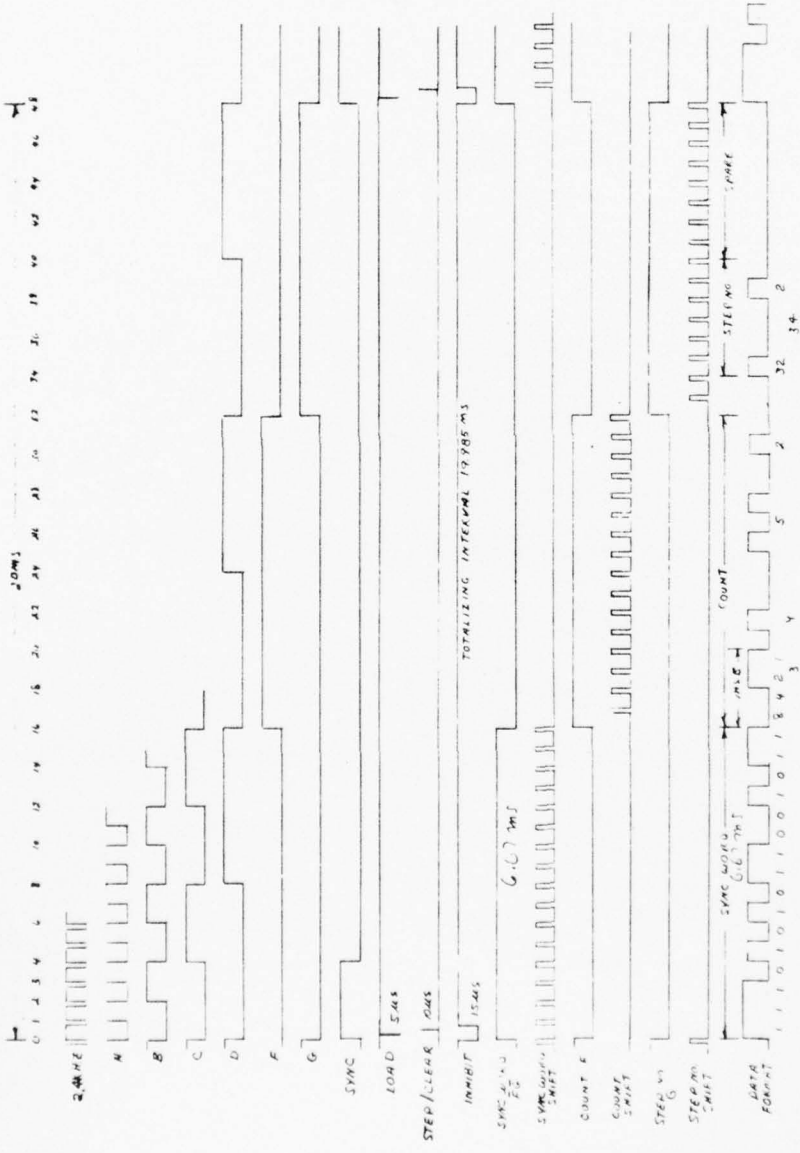

UNLESS OTHERWISE SPECIFIED		CONTRACT NO. 6-745	DATE 5-19-53
TOLERANCES		DRAWN <i>A. G. S.</i>	
.00 ±		CHECKED	
.000 ±		MECHANICAL	
ANGLES ±		ELECTRICAL	
✓ FINISHED SURFACE ROUGHNESS		PROJ. APPD	
CENTERS PERMISSIBLE		APPROVED	
DIMENSIONS IN INCHES AND APPLY AFTER PROCESSING			
MEET ASY	USED OR		
APPLICATION			

Tri-Con Associates	
TIMING DIAGRAM	
ELECTRON SPECTROMETER	
SIZE	CODE IDENT NO
C	730
SCALE	WT
	SHEET

Figure 26. Timing Diagram Electron Spectrometer

The card rack contained five printed circuit cards and two low voltage power supplies. The five cards were

- ... a timer card to generate the PCM frame logic;
- ... a test/output card which contained a test generator and also circuits to combine the electron count, step number, and sync word to make the complete PCM output waveform;
- ... a counter card;
- ... a step generator card; and
- ... a step drive card.

Schematics of the cards are given in Figures 27, 28, 29, and 30. A block diagram is given in Figure 31.

5.2.1 Ground support Equipment

A GSE console was designed and built to operate the electron spectrometer system during acceptance and environmental test, calibration, integration, and in the field prior to launch. The console was also used to decode the electron count and voltage step from the flight magnetic tape for quick look data reduction immediately after the rocket flight.

The console is very similar to that built for the RM-59/60 instruments.

A block diagram is given in Figure 32 and a timing diagram is in Figure 33.

The panel is an "inverted pan" configuration which allowed cable connectors to be located on the sides. The raised panel has room below it for electronics and power supplies. Patch cables are carried inside the cover. The case dimensions are 33 cm by 46 cm by 18 cm high. The weight is 11.5 Kg.

Four power supplies are mounted to the bottom of the case. One of these supplies 28-volt power to the instrument with separate control of both low voltage and high voltage.

A blower draws in air through the bottom of the case to cool the power supplies and electronics since the case must dissipate about 50 watts.

The electronics were contained on five printed circuit cards in a card rack fastened to the underside of the panel.

In order to sample and decode the PCM signal, the console clock must be synchronized both in phase and frequency with the PCM frame. The sync control adjusts the amplitude of the PCM data

ZONE	LTR	REVISIONS	DESCRIPTION	DATE	APPROVED

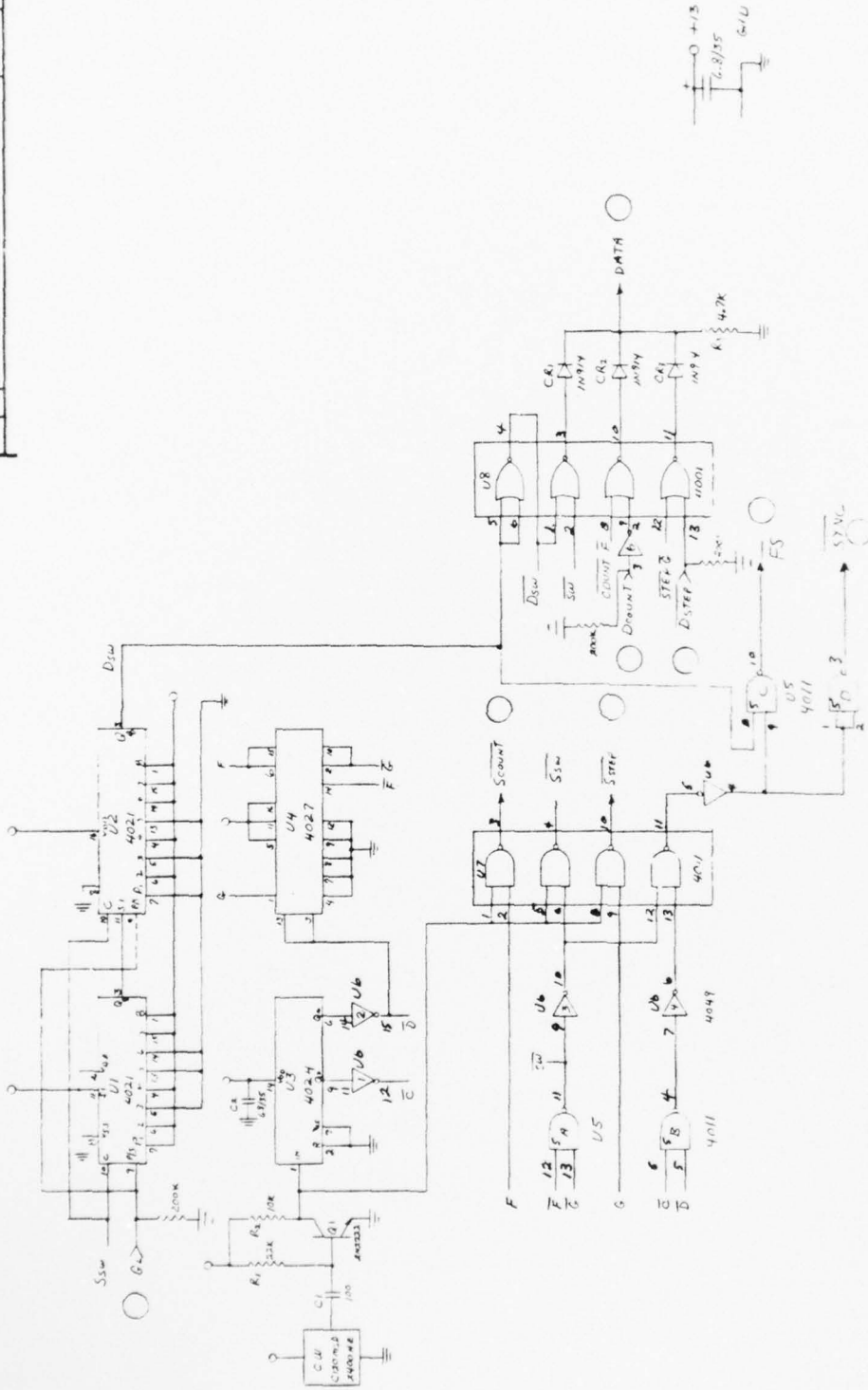

UNLESS OTHERWISE SPECIFIED		CONTRACT NO.	DATE
TOLERANCES		5-125	5-12-73
.00	±	DRAWN	S. G. J.
.000	±	CHECKED	
ANGLES	±	MECHANICAL	
✓	FINISHED SURFACE ROUGHNESS	ELECTRICAL	
CENTERS PERMISSIBLE		PROJ. APPD	
DIMENSIONS IN INCHES AND APPLY AFTER PROCESSING		APPROVED	
NEXT ASSY USED ON APPLICATION			

Tri-Con Associates	
SCHEMATIC - TIMER	SIZE CODE IDENT NO. 733
ELECTRON SPECTROMETER	SCALE 1/8" = 1"

Figure 27. Schematic - Timer Electron Spectrometer

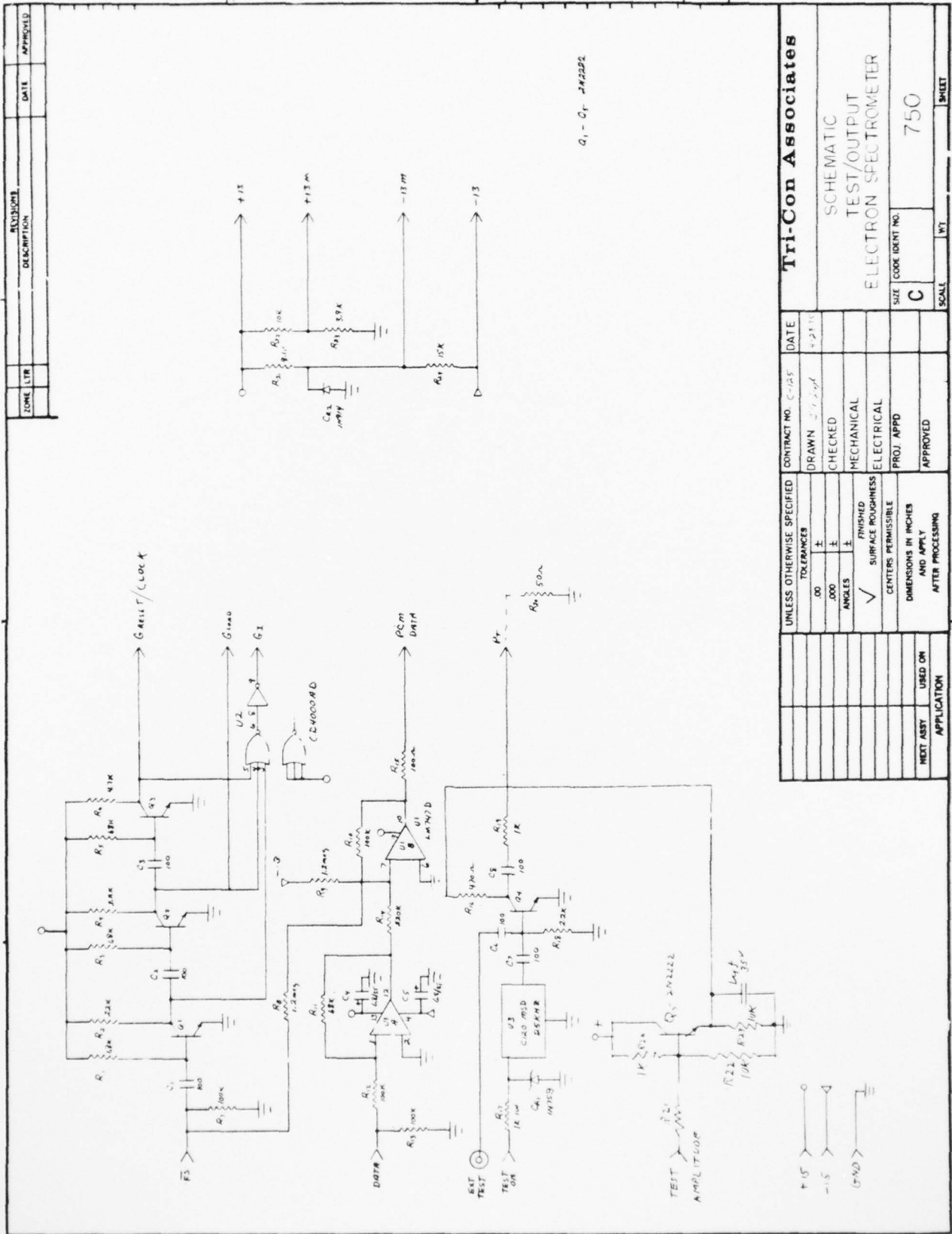

ZONE	LTR	REVISIONS	DATE	APPROVED
		DESCRIPTION		

UNLESS OTHERWISE SPECIFIED		CONTRACT NO. C-105	DATE	Tri-Con Associates	
TOLERANCES		DRAWN	4-2-75	SCHEMATIC	
.00 ±		CHECKED		TEST/OUTPUT	
ANGLES ±		MECHANICAL		ELECTRON SPECTROMETER	
✓ FINISHED SURFACE ROUGHNESS		ELECTRICAL		SIZE	CODE IDENT NO.
CENTERS PERMISSIBLE		PROJ. APPD		C	750
DIMENSIONS IN INCHES AND APPLY		APPROVED		SCALE	WT
AFTER PROCESSING					
MEET ASY	USED ON				
APPLICATION					

Figure 28. Schematic - Test/Output Electron Spectrometer

LAY

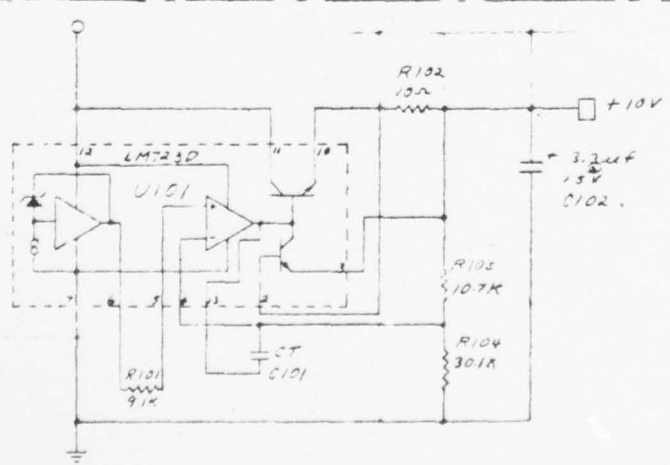
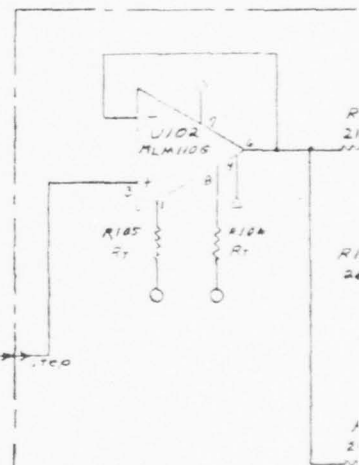
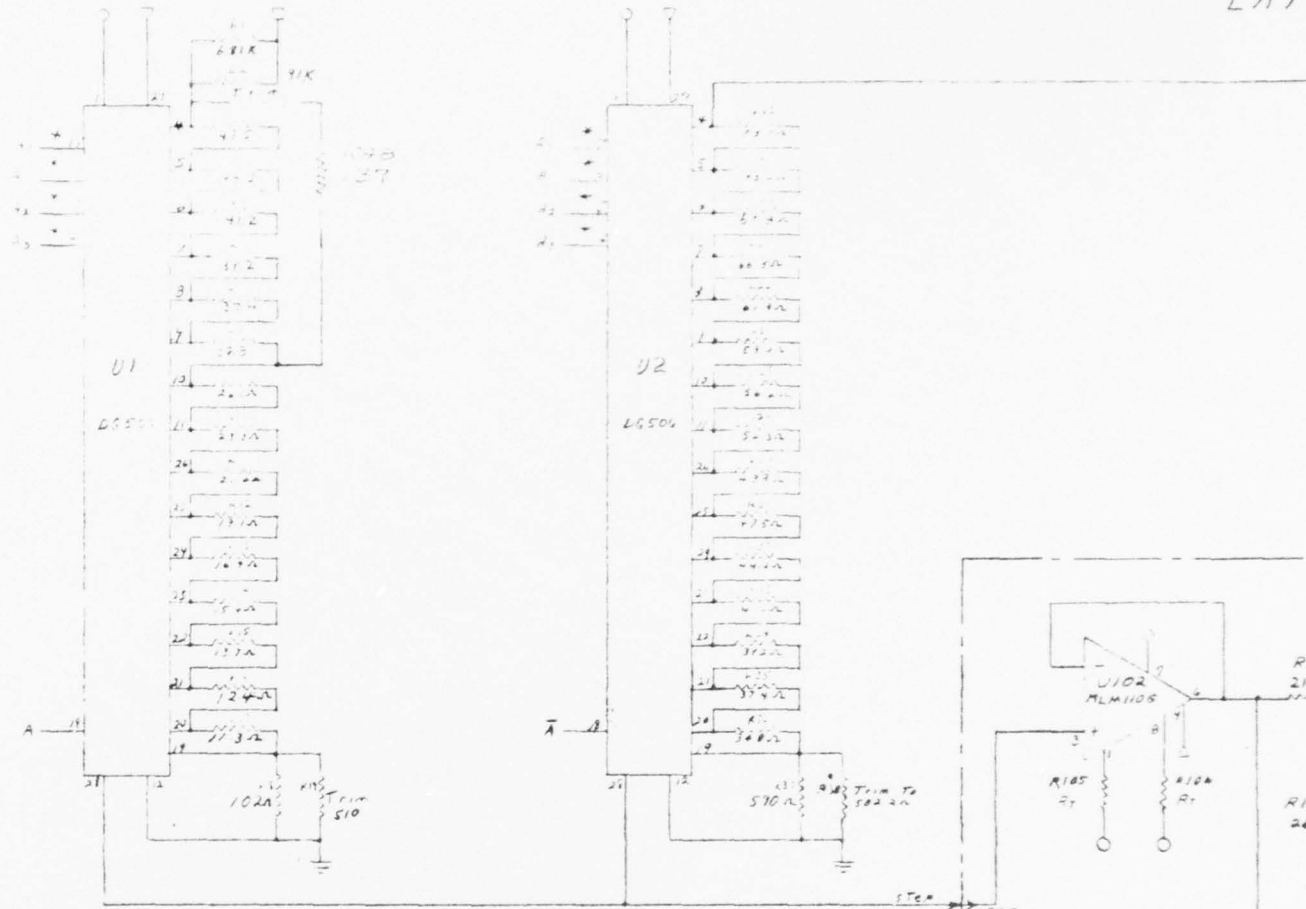

LAYOUT C

AD-A032 810

COMSTOCK AND WESTCOTT INC CAMBRIDGE MASS
DOUBLE-DECK SOLAR EXTREME ULTRAVIOLET SPECTROMETERS.(U)
JUL 76 J F MCGRATH, J P PADUR

F/G 14/2

F19628-73-C-0253
NL

UNCLASSIFIED

AFGL-TR-76-0160

2 of 2
ADA032810



END

DATE
FILMED
1 - 77

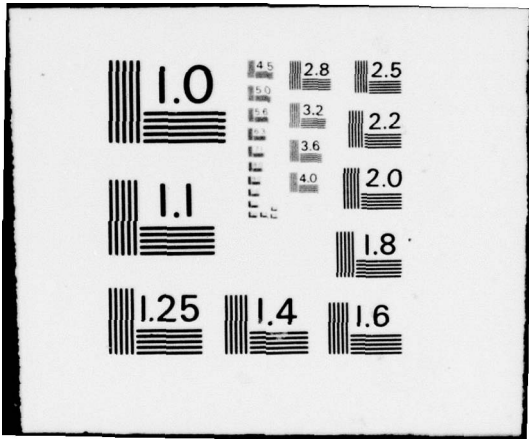

LAYOUT C 755

REVISIONS				
ZONE	LTR	DESCRIPTION	DATE	APPROVED

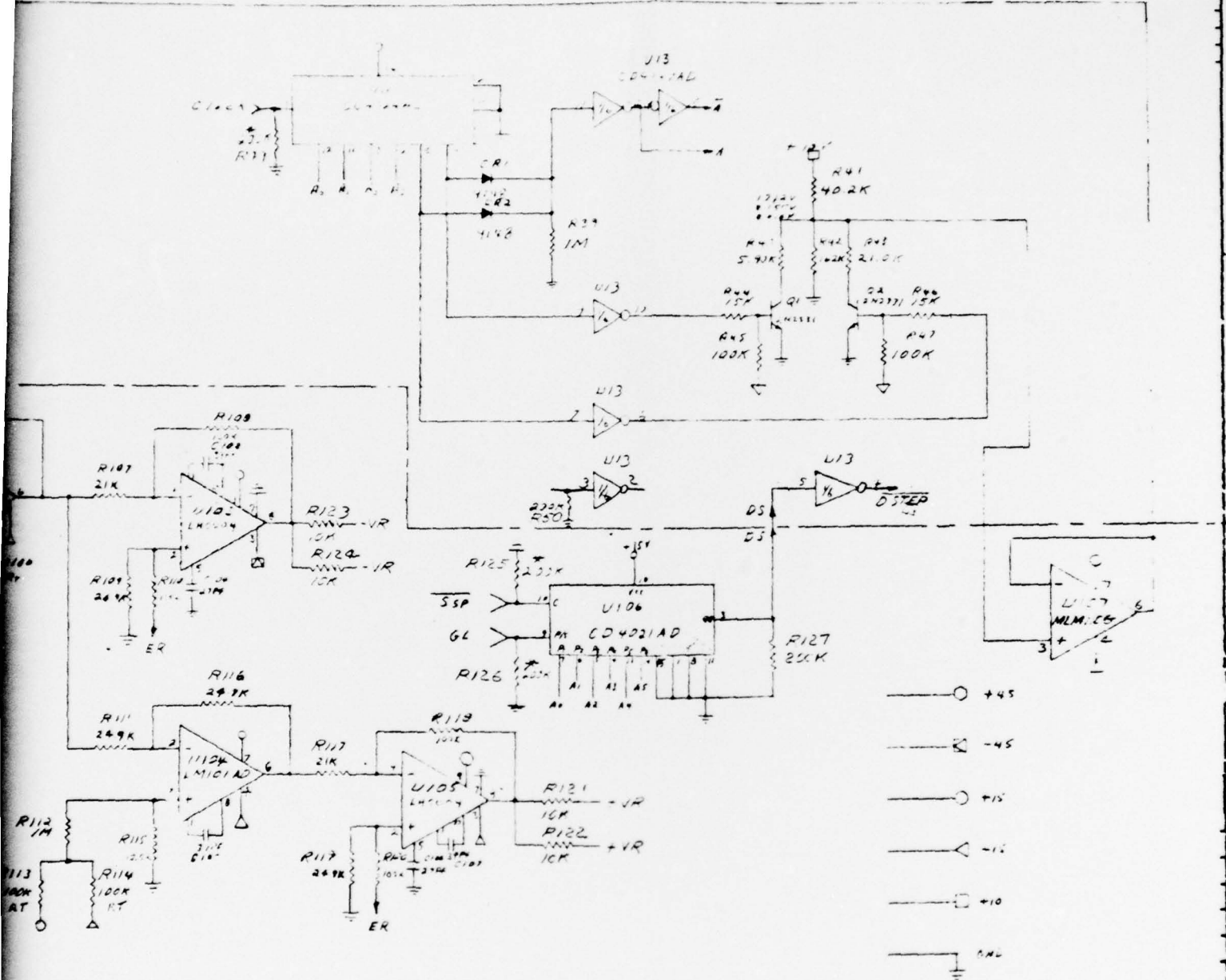

LAYOUT C 754

UNLESS OTHERWISE SPECIFIED		CONTRACT NO.	DATE	Tri-Con Associates	
TOLERANCES		DRAWN	CHECKED		
	00 ±			STEP GENERATOR ELECTRON SPECTROMETER	
	.000 ±				
	ANGLES ±			SIZE CODE IDENT NO. D 728	
	✓ FINISHED SURFACE ROUGHNESS				
	CENTERS PERMISSIBLE			SCALE WT SHEET	
	DIMENSIONS IN INCHES AND APPLY AFTER PROCESSING				
NEXT ASSY	USED ON				
APPLICATION					

Figure 30. Step Generator Electron Spectrometer

2

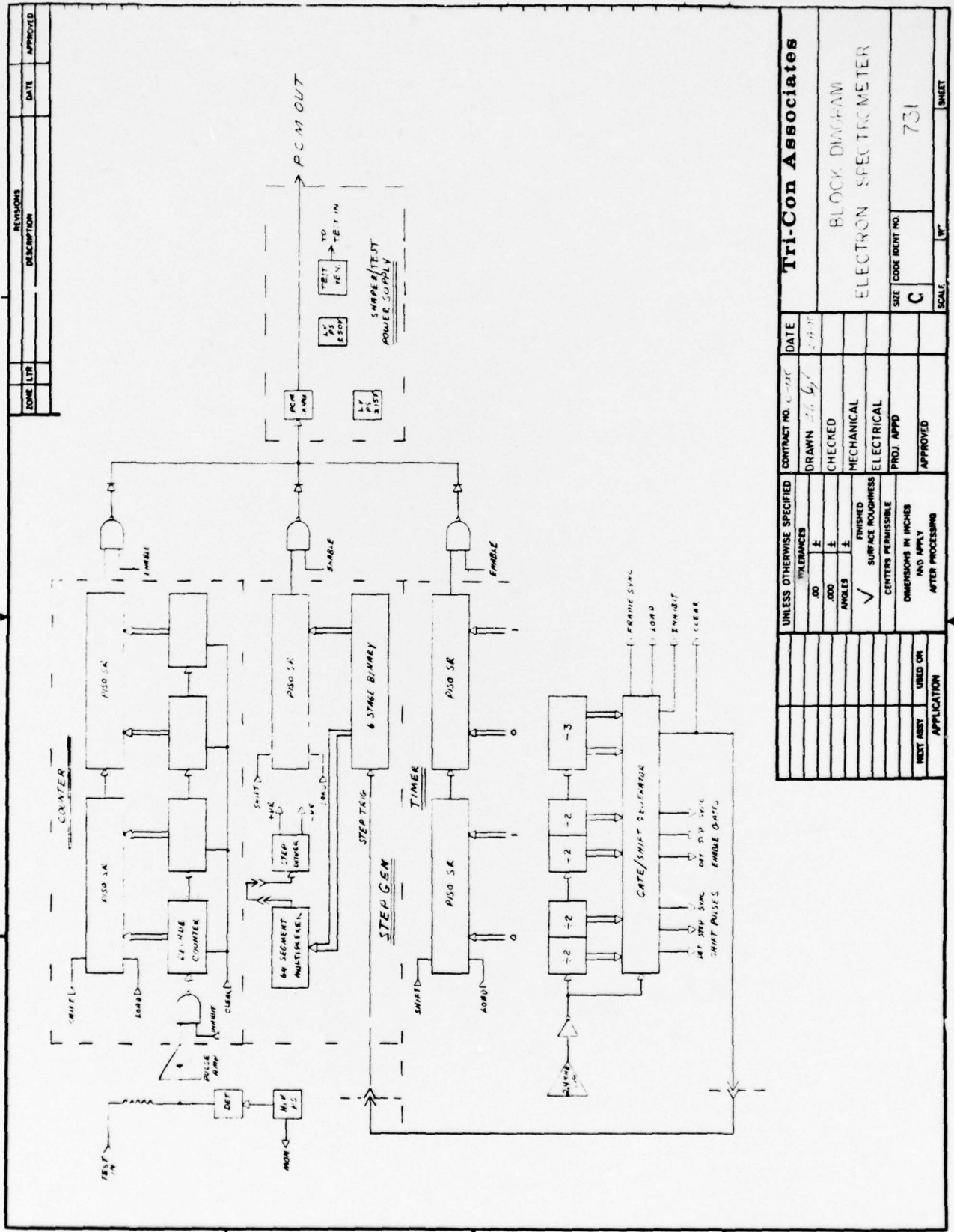

ZONE LTR	REVISIONS DESCRIPTION	DATE	APPROVED

UNLESS OTHERWISE SPECIFIED		CONTRACT NO. 10-238	DATE 3-27-57	Tri-Con Associates	
TOLERANCES	.00	DRAWN 2/16/57		BLOCK DIAGRAM	
F	.000	CHECKED		ELECTRON SPECTROMETER	
ANGLES	±	MECHANICAL		SIZE CODE BENT NO.	731
FINISHED SURFACE ROUGHNESS	✓	ELECTRICAL		SCALE	1/4"
CENTERS PERMISSIBLE DIMENSIONS IN INCHES AND APPLY AFTER PROCESSING		PROJ. APPD			
APPROVED					

Figure 31. Block Diagram - Electron Spectrometer

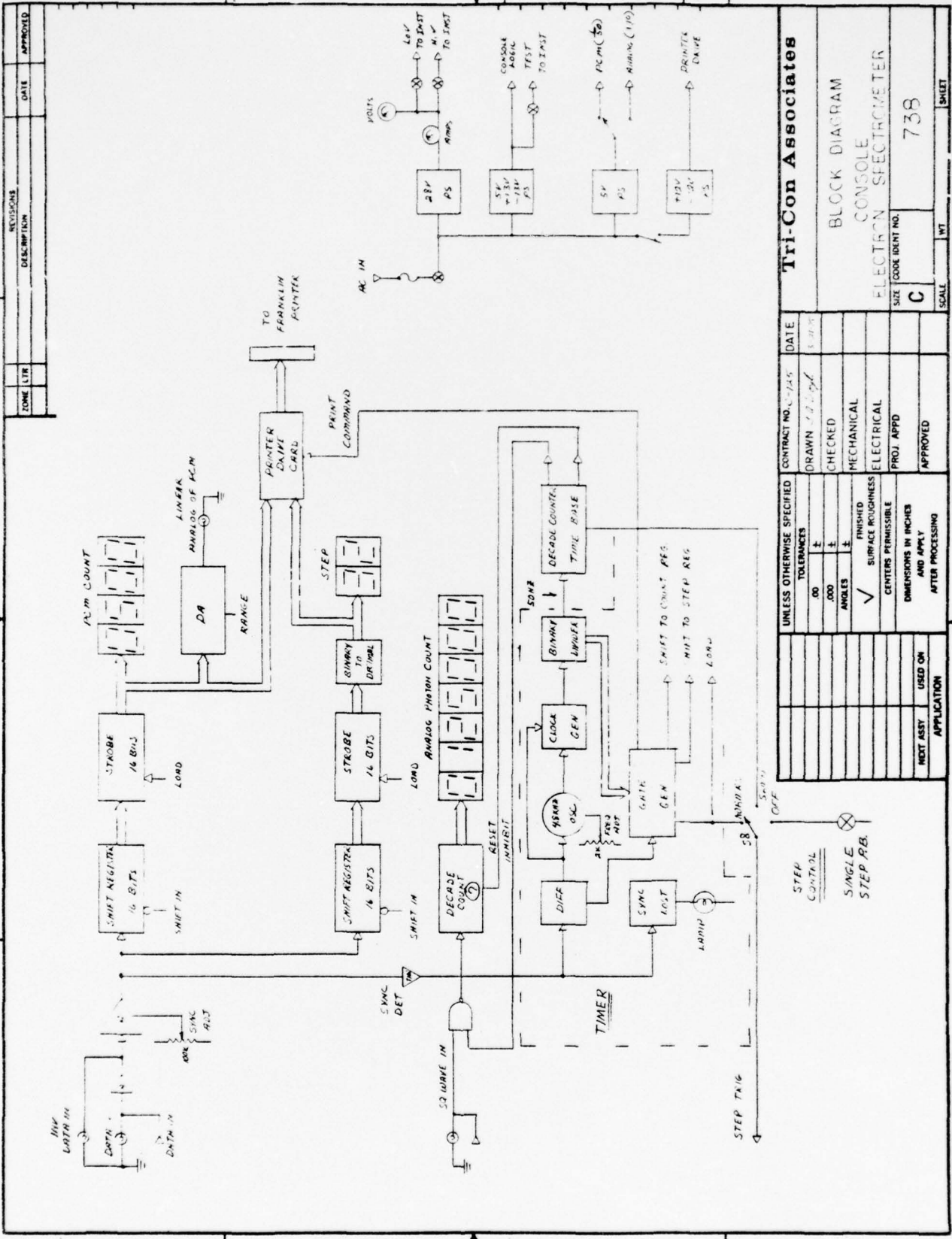

UNLESS OTHERWISE SPECIFIED		CONTRACT NO. C-745	DATE
TOLERANCES		DRAWN <i>[Signature]</i>	8-20-55
± .000		CHECKED	
± .005		MECHANICAL	
± .010		ELECTRICAL	
± .020		PROJ. APPD	
± .030		APPROVED	
± .040			
± .050			
± .060			
± .070			
± .080			
± .090			
± .100			
± .125			
± .150			
± .175			
± .200			
± .250			
± .300			
± .375			
± .450			
± .500			
± .625			
± .750			
± .875			
± 1.000			
± 1.250			
± 1.500			
± 1.750			
± 2.000			
± 2.500			
± 3.000			
± 3.750			
± 4.500			
± 5.000			
± 6.250			
± 7.500			
± 8.750			
± 10.000			
± 12.500			
± 15.000			
± 17.500			
± 20.000			
± 25.000			
± 30.000			
± 37.500			
± 45.000			
± 50.000			
± 62.500			
± 75.000			
± 87.500			
± 100.000			
± 125.000			
± 150.000			
± 175.000			
± 200.000			
± 250.000			
± 300.000			
± 375.000			
± 450.000			
± 500.000			
± 625.000			
± 750.000			
± 875.000			
± 1000.000			
± 1250.000			
± 1500.000			
± 1750.000			
± 2000.000			
± 2500.000			
± 3000.000			
± 3750.000			
± 4500.000			
± 5000.000			
± 6250.000			
± 7500.000			
± 8750.000			
± 10000.000			
± 12500.000			
± 15000.000			
± 17500.000			
± 20000.000			
± 25000.000			
± 30000.000			
± 37500.000			
± 45000.000			
± 50000.000			
± 62500.000			
± 75000.000			
± 87500.000			
± 100000.000			
± 125000.000			
± 150000.000			
± 175000.000			
± 200000.000			
± 250000.000			
± 300000.000			
± 375000.000			
± 450000.000			
± 500000.000			
± 625000.000			
± 750000.000			
± 875000.000			
± 1000000.000			

Tri-Con Associates		CONTRACT NO. C-745	DATE
BLOCK DIAGRAM			
CONSOLE			
ELECTRON SPECTROMETER			
SIZE	CODE IDENT NO.		
C	738		
SCALE	WT		
			SHEET

Figure 32. Block Diagram - Console Electron Spectrometer

ZONE	LTR	REVISIONS	DESCRIPTION	DATE	APPROVED

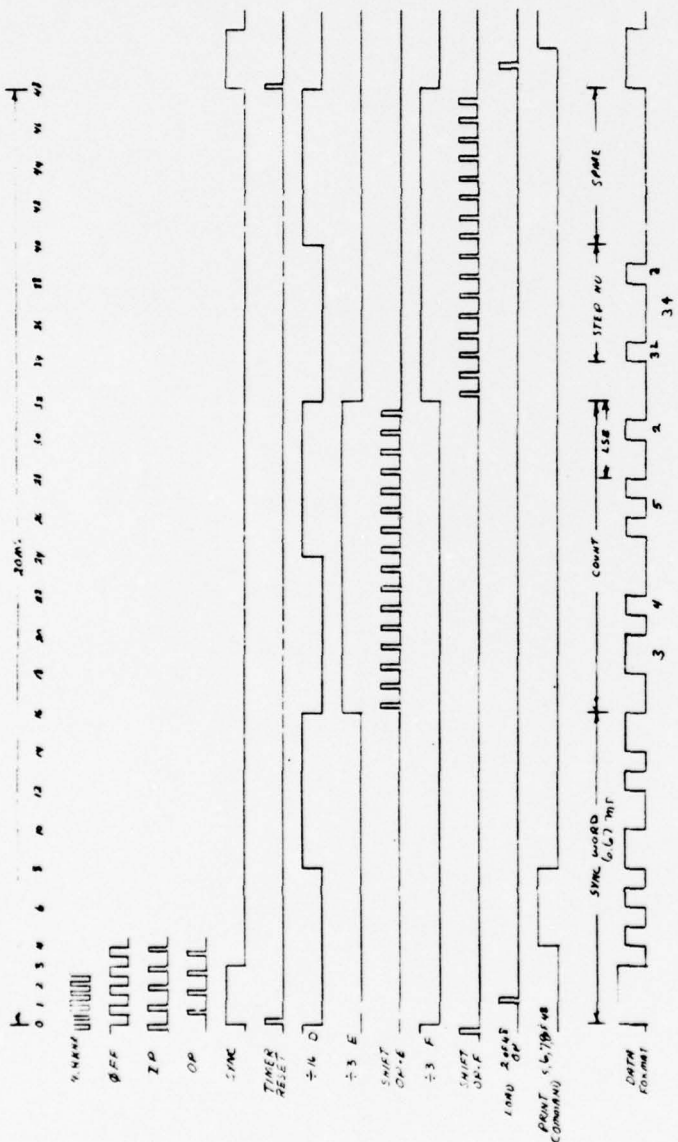

Tri-Con Associates		CONTRACT NO. C-125	DATE
DRAWN <i>S. G. G.</i>		CHECKED	1957
MECHANICAL		ELECTRICAL	
PROJ. APPD		APPROVED	
UNLESS OTHERWISE SPECIFIED		FINISHED SURFACE ROUGHNESS	
TOLERANCES		CENTERS PERMISSIBLE	
± .001	± .002	DIMENSIONS IN INCHES	
± .005	± .010	AND APPLY AFTER PROCESSING	
± .015	± .030	APPLICATION	
± .030	± .060	USED ON	
± .060	± .120		
± .120	± .250		
± .250	± .500		
± .500	± 1.000		
± 1.000	± 2.000		
± 2.000	± 4.000		
± 4.000	± 8.000		
± 8.000	± 16.000		
± 16.000	± 32.000		
± 32.000	± 64.000		
± 64.000	± 128.000		
± 128.000	± 256.000		
± 256.000	± 512.000		
± 512.000	± 1024.000		
± 1024.000	± 2048.000		
± 2048.000	± 4096.000		
± 4096.000	± 8192.000		
± 8192.000	± 16384.000		
± 16384.000	± 32768.000		
± 32768.000	± 65536.000		
± 65536.000	± 131072.000		
± 131072.000	± 262144.000		
± 262144.000	± 524288.000		
± 524288.000	± 1048576.000		
± 1048576.000	± 2097152.000		
± 2097152.000	± 4194304.000		
± 4194304.000	± 8388608.000		
± 8388608.000	± 16777216.000		
± 16777216.000	± 33554432.000		
± 33554432.000	± 67108864.000		
± 67108864.000	± 134217728.000		
± 134217728.000	± 268435456.000		
± 268435456.000	± 536870912.000		
± 536870912.000	± 1073741824.000		
± 1073741824.000	± 2147483648.000		
± 2147483648.000	± 4294967296.000		
± 4294967296.000	± 8589934592.000		
± 8589934592.000	± 17179869184.000		
± 17179869184.000	± 34359738368.000		
± 34359738368.000	± 68719476736.000		
± 68719476736.000	± 137438953472.000		
± 137438953472.000	± 274877906944.000		
± 274877906944.000	± 549755813888.000		
± 549755813888.000	± 1099511627776.000		
± 1099511627776.000	± 2199023255552.000		
± 2199023255552.000	± 4398046511104.000		
± 4398046511104.000	± 8796093022208.000		
± 8796093022208.000	± 17592186044416.000		
± 17592186044416.000	± 35184372088832.000		
± 35184372088832.000	± 70368744177664.000		
± 70368744177664.000	± 140737488355328.000		
± 140737488355328.000	± 281474976710656.000		
± 281474976710656.000	± 562949953421312.000		
± 562949953421312.000	± 1125899906842624.000		
± 1125899906842624.000	± 2251799813685248.000		
± 2251799813685248.000	± 4503599627370496.000		
± 4503599627370496.000	± 9007199254740992.000		
± 9007199254740992.000	± 18014398509481984.000		
± 18014398509481984.000	± 36028797018963968.000		
± 36028797018963968.000	± 72057594037927936.000		
± 72057594037927936.000	± 144115188075855872.000		
± 144115188075855872.000	± 288230376151711744.000		
± 288230376151711744.000	± 576460752303423488.000		
± 576460752303423488.000	± 1152921504606846976.000		
± 1152921504606846976.000	± 2305843009213693952.000		
± 2305843009213693952.000	± 4611686018427387904.000		
± 4611686018427387904.000	± 9223372036854775808.000		
± 9223372036854775808.000	± 18446744073709551616.000		
± 18446744073709551616.000	± 36893488147419103232.000		
± 36893488147419103232.000	± 73786976294838206464.000		
± 73786976294838206464.000	± 147573952589676412928.000		
± 147573952589676412928.000	± 295147905179352825856.000		
± 295147905179352825856.000	± 590295810358705651712.000		
± 590295810358705651712.000	± 1180591620717411303424.000		
± 1180591620717411303424.000	± 2361183241434822606848.000		
± 2361183241434822606848.000	± 4722366482869645213696.000		
± 4722366482869645213696.000	± 9444732965739290427392.000		
± 9444732965739290427392.000	± 18889465931478580854784.000		
± 18889465931478580854784.000	± 37778931862957161709568.000		
± 37778931862957161709568.000	± 75557863725914323419136.000		
± 75557863725914323419136.000	± 151115727451828646838272.000		
± 151115727451828646838272.000	± 302231454903657293676544.000		
± 302231454903657293676544.000	± 604462909807314587353088.000		
± 604462909807314587353088.000	± 1208925819614629174706176.000		
± 1208925819614629174706176.000	± 2417851639229258349412352.000		
± 2417851639229258349412352.000	± 4835703278458516698824704.000		
± 4835703278458516698824704.000	± 9671406556917033397649408.000		
± 9671406556917033397649408.000	± 19342813113834066795298816.000		
± 19342813113834066795298816.000	± 38685626227668133590597632.000		
± 38685626227668133590597632.000	± 77371252455336267181195264.000		
± 77371252455336267181195264.000	± 154742504910672534362390528.000		
± 154742504910672534362390528.000	± 309485009821345068724781056.000		
± 309485009821345068724781056.000	± 618970019642690137449562112.000		
± 618970019642690137449562112.000	± 1237940039285380274899124224.000		
± 1237940039285380274899124224.000	± 2475880078570760549798248448.000		
± 2475880078570760549798248448.000	± 4951760157141521099596496896.000		
± 4951760157141521099596496896.000	± 9903520314283042199192993792.000		
± 9903520314283042199192993792.000	± 19807040628566084398385987584.000		
± 19807040628566084398385987584.000	± 39614081257132168796771975168.000		
± 39614081257132168796771975168.000	± 79228162514264337593543950336.000		
± 79228162514264337593543950336.000	± 158456325028528675187087900672.000		
± 158456325028528675187087900672.000	± 316912650057057350374175801344.000		
± 316912650057057350374175801344.000	± 633825300114114700748351602688.000		
± 633825300114114700748351602688.000	± 1267650600228229401496703205376.000		
± 1267650600228229401496703205376.000	± 2535301200456458802993406410752.000		
± 2535301200456458802993406410752.000	± 5070602400912917605986812821504.000		
± 5070602400912917605986812821504.000	± 10141204801825835211973625643008.000		
± 10141204801825835211973625643008.000	± 20282409603651670423947251286016.000		
± 20282409603651670423947251286016.000	± 40564819207303340847894502572032.000		
± 40564819207303340847894502572032.000	± 81129638414606681695789005144064.000		
± 81129638414606681695789005144064.000	± 162259276829213363391578010288128.000		
± 162259276829213363391578010288128.000	± 324518553658426726783156020576256.000		
± 324518553658426726783156020576256.000	± 649037107316853453566312041152512.000		
± 649037107316853453566312041152512.000	± 1298074214633707007132624082305024.000		
± 1298074214633707007132624082305024.000	± 2596148429267414014265248164610048.000		
± 2596148429267414014265248164610048.000	± 5192296858534828028530496293220096.000		
± 5192296858534828028530496293220096.000	± 10384593717069656057060992466440192.000		
± 10384593717069656057060992466440192.000	± 20769187434139312114121984932880384.000		
± 20769187434139312114121984932880384.000	± 41538374868278624228243969865760768.000		
± 41538374868278624228243969865760768.000	± 83076749736557248456487939731521536.000		
± 83076749736557248456487939731521536.000	± 166153499473114496912975879463042784.000		
± 166153499473114496912975879463042784.000	± 332306998946228993825951759326085568.000		
± 332306998946228993825951759326085568.000	± 664613997892457987651903518652171136.000		
± 664613997892457987651903518652171136.000	± 1329227995784915975303807037304342272.000		
± 1329227995784915975303807037304342272.000	± 2658455991569831950607614074608684448.000		
± 2658455991569831950607614074608684448.000	± 5316911983139663901215228149217368896.000		
± 5316911983139663901215228149217368896.000	± 10633823966279327802430456298434737792.000		
± 10633823966279327802430456298434737792.000	± 21267647932558655604860912596869475584.000		
± 21267647932558655604860912596869475584.000	± 42535295865117311209721825193738951168.000		
± 42535295865117311209721825193738951168.000	± 8507059173023462241944365038747790336.000		
± 8507059173023462241944365038747790336.000	± 17014118346046924483888730077495580672.000		
± 17014118346046924483888730077495580672.000	± 34028236692093848967777460154991161344.000		
± 34028236692093848967777460154991161344.000	± 68056473384187697935554920309982322688.000		
± 68056473384187697935554920309982322688.000	± 136112946768375395871109840619964645376.000		
± 136112946768375395871109840619964645376.000	± 272225893536750791742219681239292907744.000		
± 272225893536750791742219681239292907744.000	± 544451787073501583484439362478585815488.000		
± 544451787073501583484439362478585815488.000	± 108890357414700316696887872495717162976.000		
± 108890357414700316696887872495717162976.000	± 21778071482940063339377574499143525952.000		
± 21778071482940063339377574499143525952.000	± 43556142965880126678755148998287051904.000		

signal to match the frame-sync detector threshold. Improper adjustment was indicated by the SYNC LOST lamp. When the lamp was off, the console clock was being locked in phase with the PCM data frame at the start of each frame. The frequency of the console clock was adjusted to match the PCM bit rate by the FREQUENCY control. Proper adjustment was achieved when the correct test count was displayed on the PCM PHOTON count readout. The test count generator in the instrument was enabled by 28 volts controlled by the TEST COUNT toggle switch on the console panel. The correct count was 500 (25000 pulses per second counted for 20 milliseconds).

With the test harness connected to the test connector on the instrument, the voltage in the instrument was controlled by the console. (In flight, the voltage was stepped when its stepping logic was triggered by a pulse generated in the flight timer electronics.) The console generated and controlled separate trigger pulses.

With the step control on NOR (normal) the analyzer voltage was stepped at the normal rate of 50 per second. With the switch on SLO, the rate was 1 per second.

To assist in calibration, the console contained a 7-digit decade scaler which measured the frequency of the square wave output of the instrument. The count accumulated in either 1 or 10 seconds, as selected by the TIME BASE switch, was displayed on the readout labeled PHOTON COUNT. The number displayed was one-half the actual photon count. The lamp to the right of the display indicated when the counter gate was open. The display time was two seconds in both the 1-second and 10-second count modes. The SQUARE WAVE BNC connector provided a buffered output square wave signal that could be counted by an external counter, if desired. The time base for the 1-second and 10-second counting intervals was derived from the console clock which was synchronized with the instrument crystal clock and thus was accurate to ± 0.01 percent.

An analog voltage proportional to either the three most or three least decimal digits of the PCM PHOTON COUNT was brought out on the BNC connector labeled OUT. The most (M) or least (L) significant digits were selected by the ANALOG OF PCM switch.

The console could be used to display PCM photon count and wavelength as decoded from a PCM signal derived from a real time

telemetry signal or magnetic tape playback. In this case the data were usually inverted in sense and could be handled by using the INVERTED DATA BNC input connector. The connector labeled DATA was either input or output since it was in parallel with the data wire on the console instrument connector.

The photon count BCD information was converted to an analog voltage by an Analog Devices, Inc. digital-to-analog converter Model DAC-12QZ. Three BCD digits were converted to a 10 volt full scale output with a linearity error of \pm the least significant bit. The analog output was useful for producing a count versus voltage step plot from magnetic tape of the flight data.

Schematics of the console printed circuit cards are given in Figures 34, 35, 20, 36, and 22.

The console was used to operate the instrument during calibration. It was used at Ball Brothers Research Corporation for the integration and performance tests.

Immediately after launch, the console was used to produce quick look data reduction at the site telemetry station.

5.3 Photometer Electronics

An electronic subsystem was designed and built to interface the output pulses from a government furnished photometer detector assembly with the rocket PCM telemetry system. Electronics to energize a mechanism for alternate insertion of two filters in front of the detector was also made.

The government-furnished detector included a photomultiplier, high voltage power supply, and pulse amplifier. The output pulses from the pulse amp were counted and converted to PCM data along with a sync word and filter position information by circuits on three printed circuit cards which were located in a separate section of the electron spectrometer assembly. A block diagram is shown in Figure 37 and a timing diagram in Figure 38.

The timer card generated PCM frame logic at the rate of 10 frames per second. The counter card contained a 4-digit decimal counter and shift register. Thus, the system was capable of handling pulse rates up to 100,000 pulses per second directly. Since the counter recycles to zero and fills again if there are more than 10,000 counts per frame, by inspection of the data the number of recycles can be determined and a very high count rate can be measured.

The power supply/output card contained a ± 15 volt power supply and output shaper.

Schematics are given in Figures 39, 29, and 40.

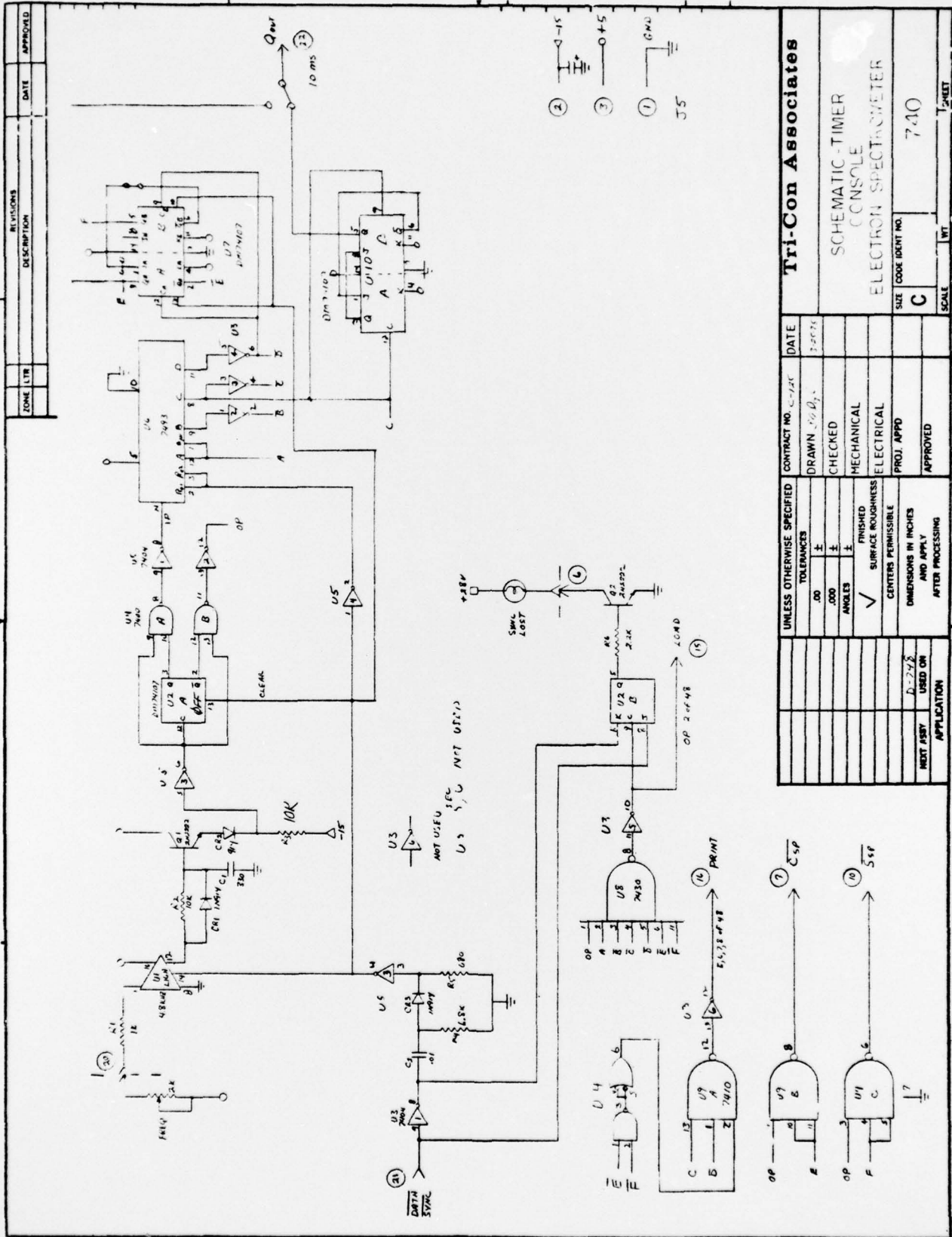

Figure 34. Schematic - Timer Console Electron Spectrometer

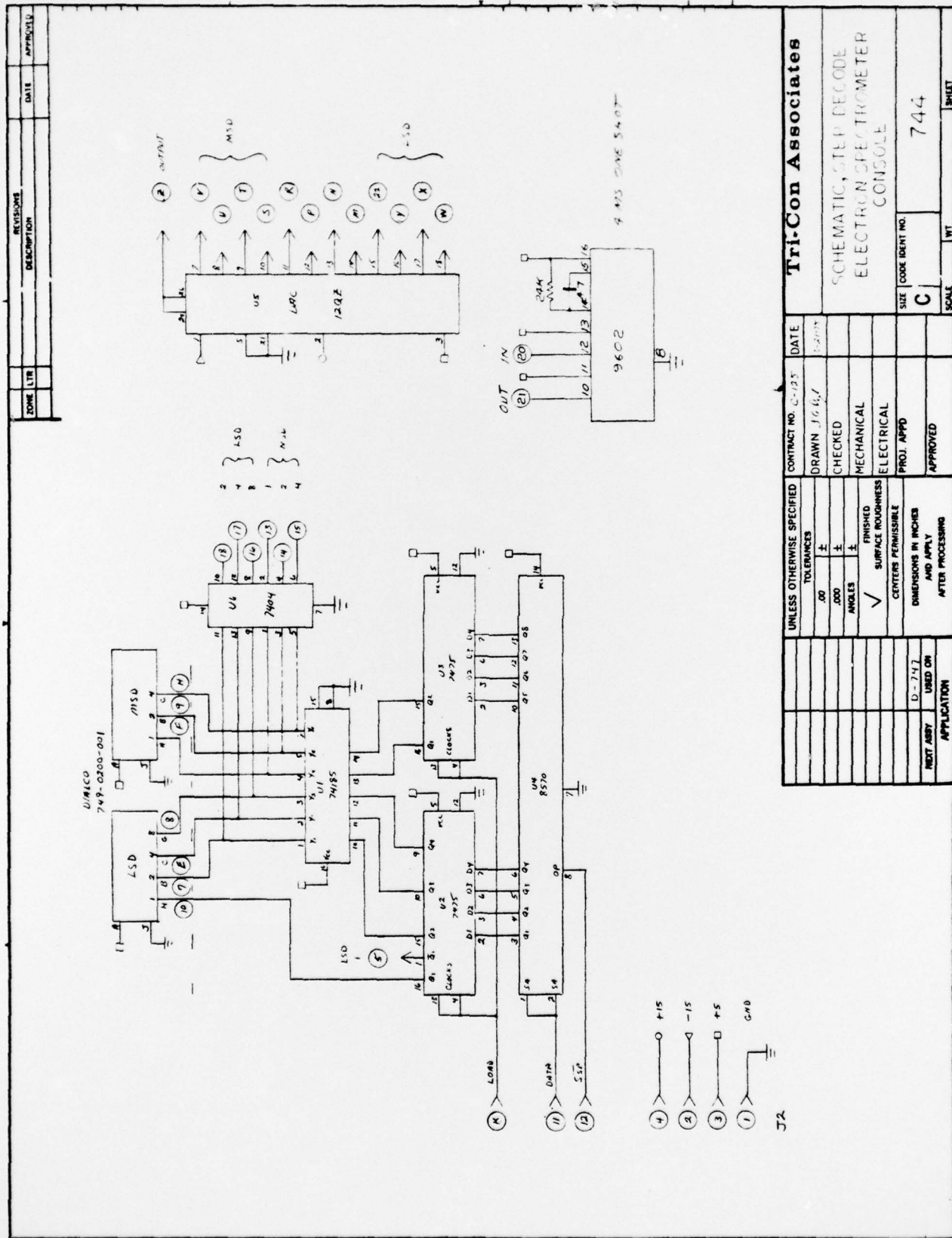

Figure 35. Schematic, Step Decode Electron Spectrometer Console

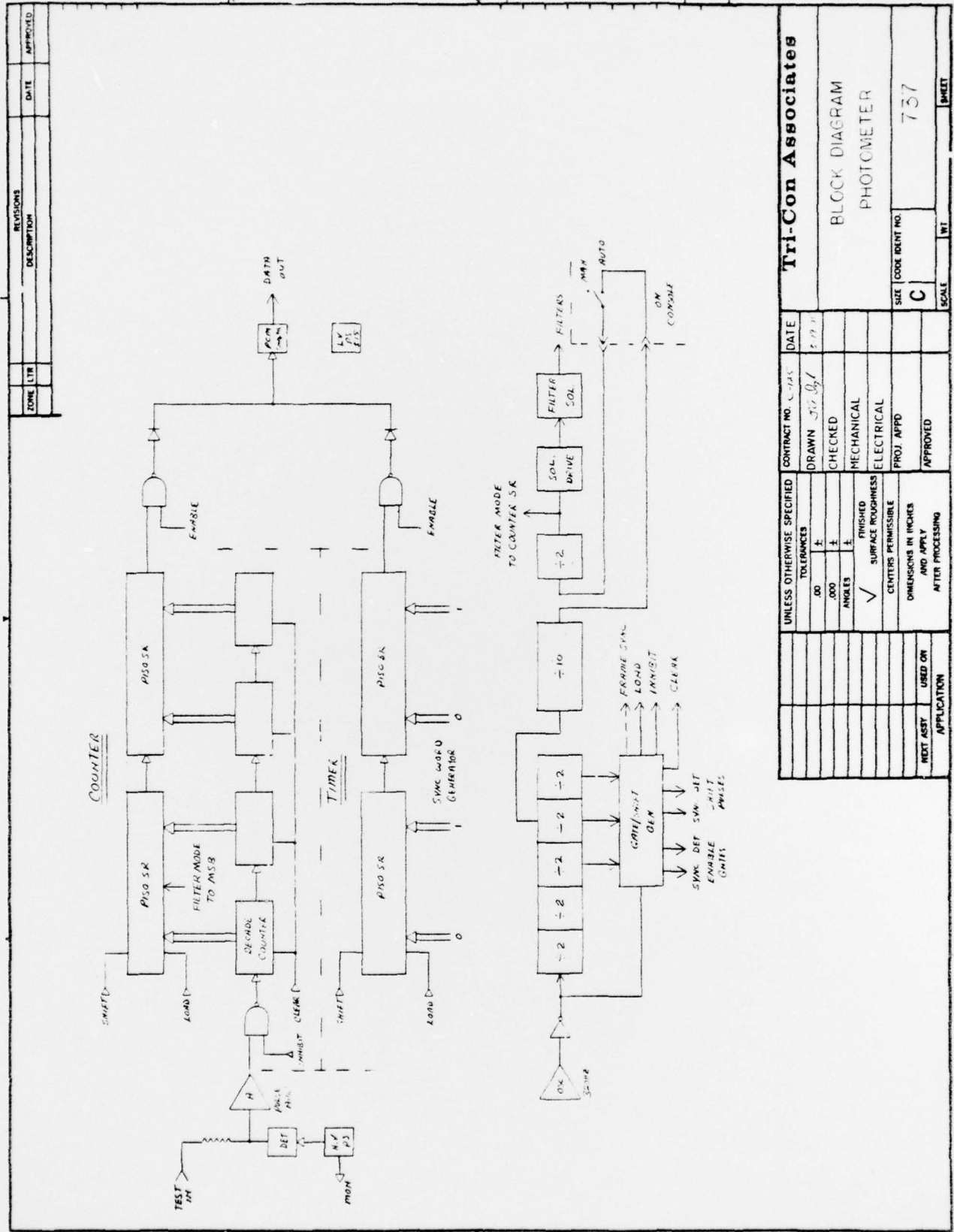
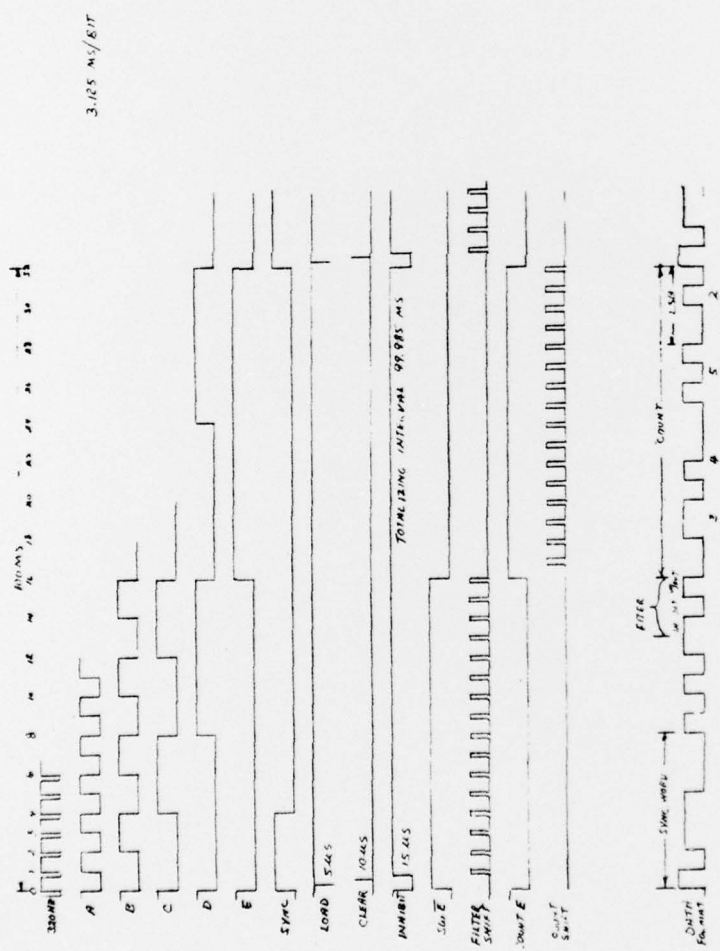

Figure 37. Block Diagram - Photometer

ZONE	REVISES	DATE	APPROVED
	DESCRIPTION		



UNLESS OTHERWISE SPECIFIED		CONTRACT NO. C-125	DATE
TOLERANCES		DRAWN 10/6/67	7-19-68
.00 ±		CHECKED	
.000 ±		MECHANICAL	
.005 ±		ELECTRICAL	
✓ FINISHED SURFACE ROUGHNESS		PROJ. APPD	
CENTERS PERMISSIBLE		APPROVED	
DIMENSIONS IN INCHES AND APPLY AFTER PROCESSING			
NEXT ASY	USED ON		
APPLICATION			
Tri-Con Associates		SIZE	CODE IDENT NO.
TIMING DIAGRAM		C	729
PHOTOMETER		SCALE	1/1

Figure 38. Timing Diagram - Photometer

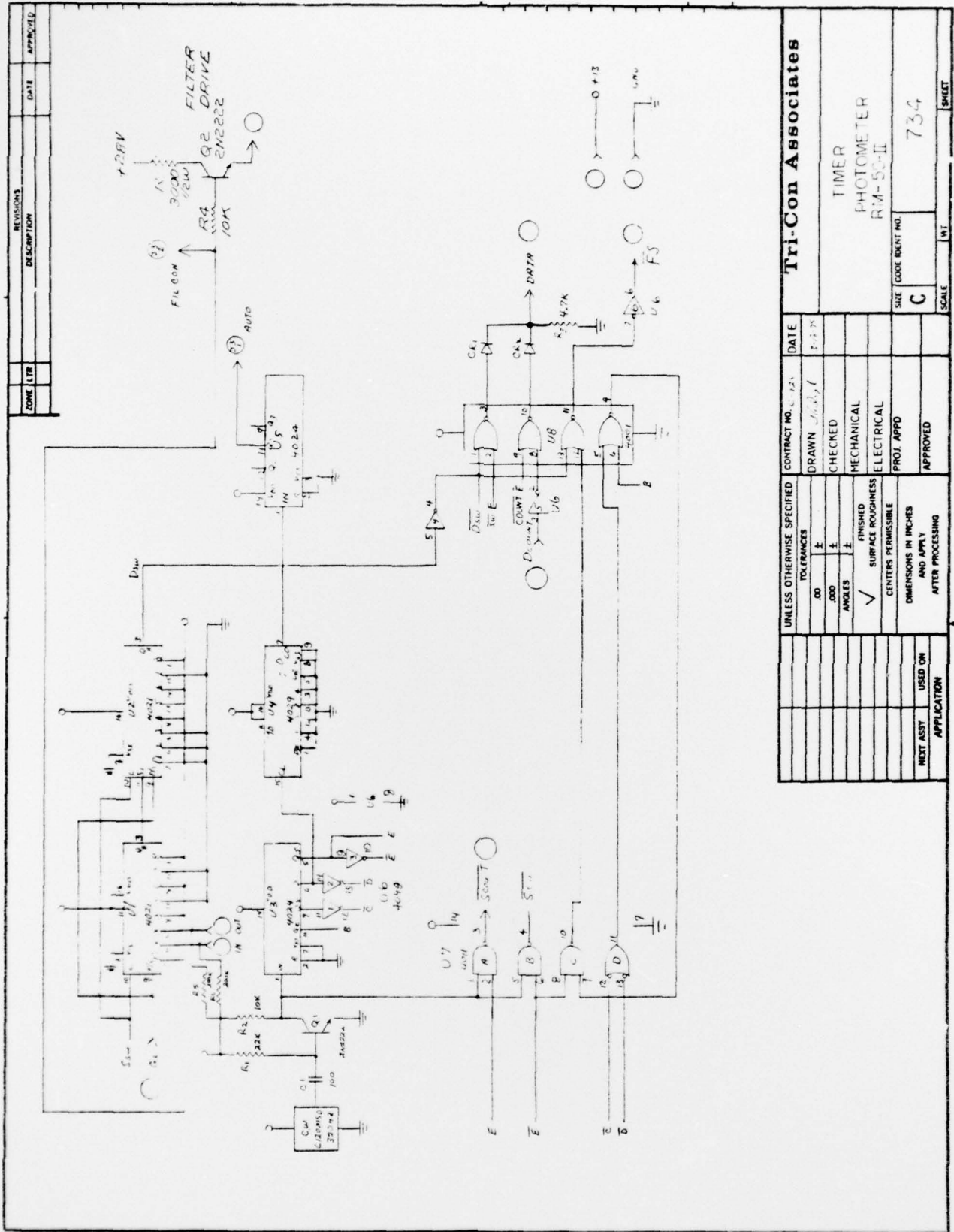

ZONE LTR	REVISIONS	DESCRIPTION	DATE	APPROVED

UNLESS OTHERWISE SPECIFIED		CONTRACT NO.	DATE
TOLERANCES		7-12-51	7-12-51
.00	±		
.000	±		
ANGLES	±		
FINISHED SURFACE ROUGHNESS			
CENTERS PERMISSIBLE			
DIMENSIONS IN INCHES AND APPLY AFTER PROCESSING			
MECHANICAL	CHECKED		
ELECTRICAL			
PROJ. APPD			
APPROVED			
NEXT ASY	USED ON		
APPLICATION			

Tri-Con Associates	
TIMER PHOTOMETER RM-59-II	
SIZE (CODE IDENT NO.)	734
SCALE	
WT	
SHEET	

Figure 39. Timer Photometer RM-59-II

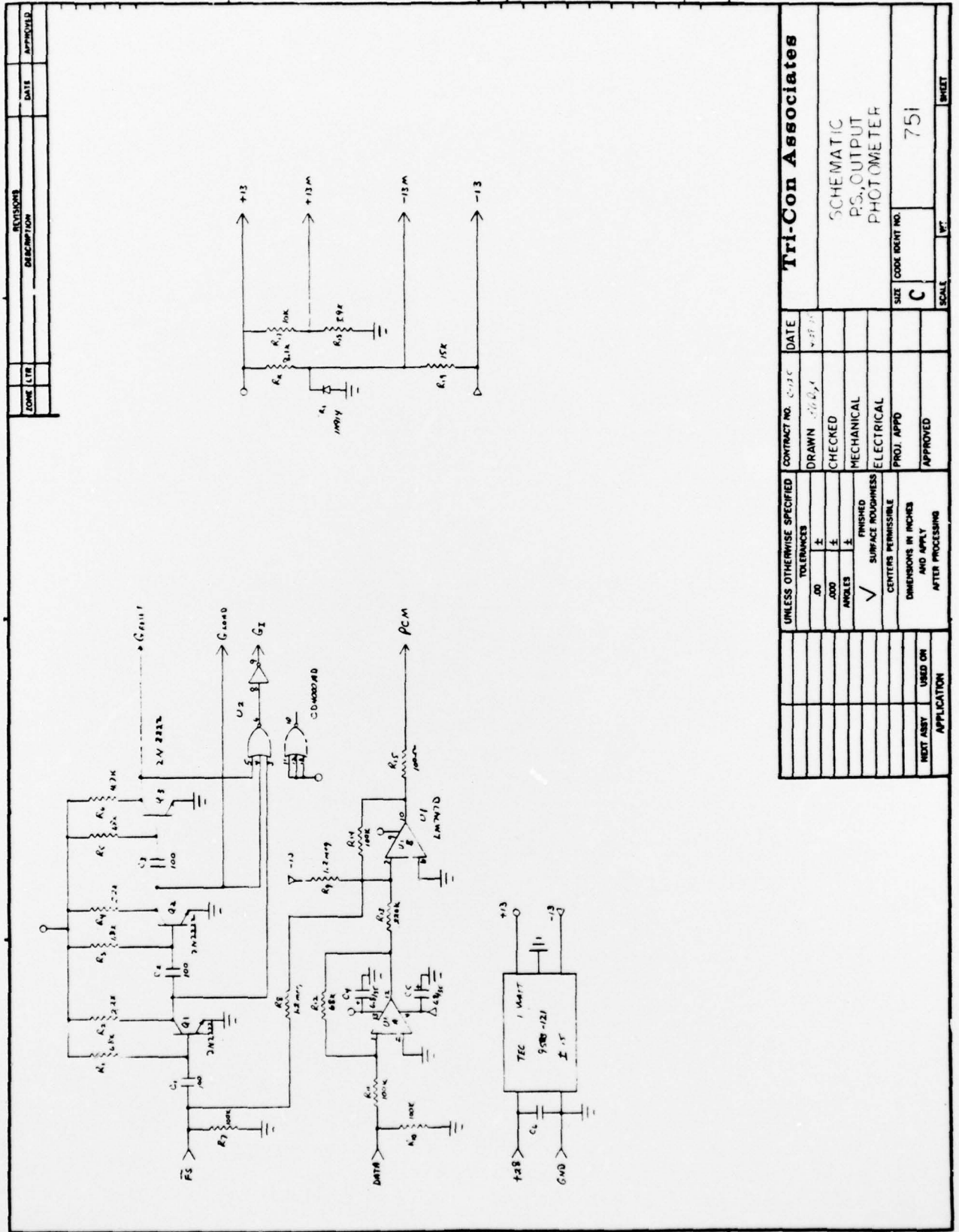

REVISIONS	DATE	APPROVED

UNLESS OTHERWISE SPECIFIED		CONTRACT NO.	DATE
TOLERANCES		4250	4-25-61
DIM	±		
ANGLES	±		
FINISHED SURFACE IRREGULARITIES			
CENTERS PERMISSIBLE			
DIMENSIONS IN PARENTS AND APPLY AFTER PROCESSING			
MFG ASY	USED OR APPLICATION		

Tri-Con Associates	
SCHEMATIC P.S. OUTPUT PHOTOMETER	
SIZE CODE BENT NO.	751
SCALE	1" = 1"
SHEET	1

Figure 40. Schematic P.S., Output Photometer

5.3.1 Ground Support Equipment

To operate the photometer system during acceptance and environmental test, calibration, integration, and in the field prior to launch, a console that already existed was modified to operate at the correct frame rate and format.

A new timer card was designed and fabricated. A timing diagram is given in Figure 41 and a schematic in Figure 42. The data decode card and time base card were used without modification. Schematics are given in Figures 20 and 36. The printer drive card of the original console was also used. See Figure 22.

5.4 Field Support Services

Support services were provided for integration of this instrument and its auxiliary experiments with the pointing control at Ball Brothers Research Corporation in Boulder, Colorado, and also at the launch facility at WSMR, New Mexico. Leak checks were made on the nose cone and F-section at both times. These services are detailed in a letter report to the Contract Monitor dated 1 March 1976.

The payload was launched (with the nose cone evacuated) at 1220 MST on 24 February 1976 aboard an Aerobee 170 rocket from the Aerobee 350 Tower at White Sands Missile Range in New Mexico. Data were received from the Electron

Spectrometer, the side viewing Photometer, as well as from seven of the eight CEM detectors (no data again from the 1206⁰A detector). Due to a separation of the instrument payload between the F- and E-sections upon chute deployment, a successful recovery was not obtained. Some of the payload components were recovered a few weeks later, but due to the damaged condition of these components, a comprehensive post-launch analysis of the detector problem could not be carried out.

REVISED	DATE	APPROVED
DESCRIPTION		

3.105 MS/617

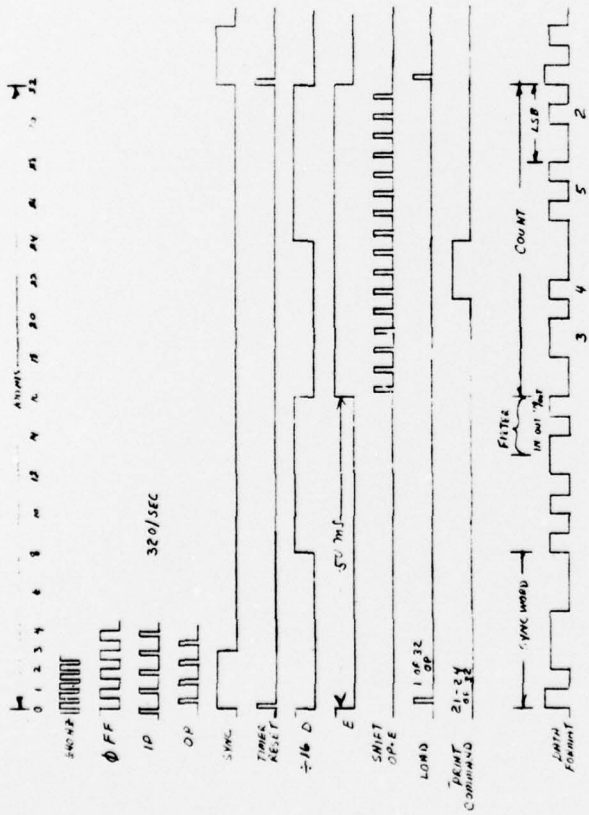

UNLESS OTHERWISE SPECIFIED		CONTRACT NO. 4-105	DATE 3-10-58
TOLERANCES		DRAWN 10/24	
.00 ±		CHECKED	
.000 ±		MECHANICAL	
ANGLES ±		ELECTRICAL	
✓ FINISHED SURFACE ROUGHNESS		PPD. APPD	
CLYTERS PERMISSIBLE		APPROVED	
DIMENSIONS IN INCHES AND APPLY AFTER PROCESSING			
MEET ASSY USED ON APPLICATION			

Tri-Con Associates	
TIMING DIAGRAM	
PHOTOMETER, CONSOLE	
SIZE	735
SCALE	
WT	
SHEET	

Figure 41. Timing Diagram Photometer, Console

