

AD-A032 838

ARMY COMMUNICATIONS-ELECTRONICS ENGINEERING INSTALLAT--ETC F/G 17/2
DIGITAL TRANSMISSION EVALUATION PROJECT RDS-806 TEST.(U)
FEB 75 H F BOWER, E F NEW, D M LAIDA

UNCLASSIFIED

CCC-CED-75-DTEP-003

NL

| OF |
AD
A032 838

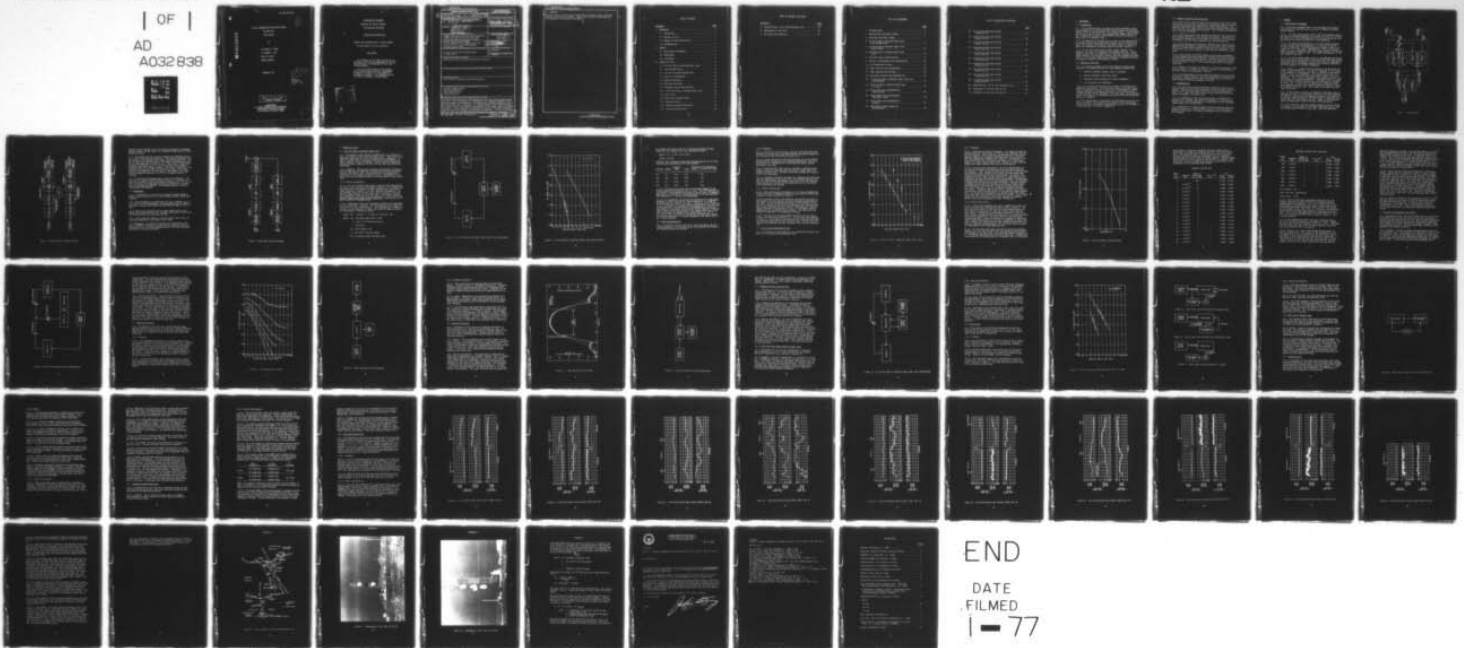

1

DIGITAL TRANSMISSION EVALUATION PROJECT

RDS-80G TEST

FINAL REPORT

BY

CPT HAROLD F. BOWER

1LT EDWARD F. NEW

DAVID M. LAIDA

ARNOLD HEMMILA

FEBRUARY 1975

DDC
RECEIVED
DEC 2 1976
A

ADA 032838

DISTRIBUTION STATEMENT A
Approved for public release;
Distribution Unlimited

HEADQUARTERS
U.S. ARMY COMMUNICATIONS-ELECTRONICS
ENGINEERING INSTALLATION AGENCY
Fort Huachuca, Arizona 85613

1473

DISTRIBUTION STATEMENT

Approved for public release.

Distribution unlimited.

DISPOSITION INSTRUCTIONS

Destroy this document when no longer needed.

Do not return it to the originator.

DISCLAIMER

The findings in this report are not to be construed as an Official Department of the Army position unless so designated by other authorized documents.

The use of trade names in this document does not constitute an official endorsement of approval of the use of such commercial hardware or software. This document may not be cited for purpose of advertisement.

ACCESSION for

NTIS	Write Section	<input checked="" type="checkbox"/>
DOC	Roll Section	<input type="checkbox"/>
UP/DOWN		
DATE/TIME		
CY		
DISTRIBUTION/AVAILABILITY CODES		
APPENDIX OF SERIAL		

A

UNCLASSIFIED

SECURITY CLASSIFICATION OF THIS PAGE (When Data Entered)

REPORT DOCUMENTATION PAGE		READ INSTRUCTIONS BEFORE COMPLETING FORM
1. REPORT NUMBER	2. GOVT ACCESSION NO.	3. RECIPIENT'S CATALOG NUMBER
4. CCC-CED-75-DTEP-003, CCC-CED-DTEP-004		
4. TITLE (and Subtitle)		5. TYPE OF REPORT & PERIOD COVERED
DIGITAL TRANSMISSION EVALUATION PROJECT RDS-80G TEST. FINAL REPORT		FINAL REPORT. 19 Aug -
6. PERFORMING ORG. REPORT NUMBER		7. AUTHOR(s)
CCC-CED-DTEP-004 16 Dec 74		CPT Harold F. Bower, LT Edward F. New, David M. Laida Arnold/Hemmila
9. PERFORMING ORGANIZATION NAME AND ADDRESS		10. PROGRAM ELEMENT, PROJECT, TASK AREA & WORK UNIT NUMBERS
US Army Communications-Electronics Engineering Installation Agency & US Army Electronic Proving Grounds, Ft Huachuca, Az 85613		12. 60 p.
11. CONTROLLING OFFICE NAME AND ADDRESS		12. REPORT DATE
US Army Communications Command, Assistant Chief of Staff for Force Development, Ft Huachuca, AZ 85613		28 Feb 75
14. MONITORING AGENCY NAME & ADDRESS (if different from Controlling Office)		13. NUMBER OF PAGES
US Army Communications Systems Agency, Ft Monmouth, NJ		53
		15. SECURITY CLASS. (of this report)
		Unclassified
		15a. DECLASSIFICATION/DOWNGRADING SCHEDULE
16. DISTRIBUTION STATEMENT (of this Report)		
Approved for public release; distribution unlimited.		
17. DISTRIBUTION STATEMENT (of the abstract entered in Block 20, if different from Report)		
18. SUPPLEMENTARY NOTES		
To be entered in Defense Documentation Center		
19. KEY WORDS (Continue on reverse side if necessary and identify by block number)		
microwave communication digital communication Phase Shift Keying Angle Modulation		
20. ABSTRACT (Continue on reverse side if necessary and identify by block number)		
The Raytheon RDS-80G digital multiplex/radio system was tested in back-to-back and actual link configuration for determination of transfer parameters and to develop standard test techniques. The system has a maximum propagation rate of 20.85 Mb/s (312 voice channels) in a 14 MHz bandwidth in the 8 GHz band. BER vs RSL characteristics are displayed and analyzed as the primary mode of equipment evaluation. Actual link data is presented for analysis of cross-polarization characteristics and fading at two microwave frequencies. Carrier to interference data, T1 line tests and theoretical predictions are compared. Frequency		

DD FORM 1 JAN 73 1473 EDITION OF 1 NOV 65 IS OBSOLETE

UNCLASSIFIED 405 982

SECURITY CLASSIFICATION OF THIS PAGE (When Data Entered)

20. ABSTRACT:

stability, data rate variations, pulse jitter, switching errors, and frame time were measured and discussed. Power spectral density characteristics are compared to FCC spectrum requirements.

TABLE OF CONTENTS

<u>PARAGRAPH</u>	<u>PAGE</u>
1. BACKGROUND	1
1.1 Introduction	1
1.2 Approach to Task	1
1.3 Summary of Results/Conclusion.	2
1.4 Recommendations.	2
2. GENERAL	3
2.1 Description of Equipment	3
2.2 Methodology.	6
2.3 Limitations.	6
3. DETAILS OF TESTS.	8
3.1 Bit Error Rate vs Received Signal Level.	8
3.2 Link Characteristics	11
3.3 Link Bit Error Rate Availability	12
3.4 Carrier to Interference.	18
3.5 Spectrum Evaluation.	20
3.6 Data Rate Variations	23
3.7 Frequency Accuracy and Stability	26
3.8 T1 Bit Error Rate vs Received Signal Level	26
3.9 Pulse Jitter	28
3.10 Mean Time to Acquire Frame.	31
3.11 Switching Errors.	31
3.12 Interface Between Multiplexers.	34
3.13 Cross-Polarization Test	36

TABLE OF CONTENTS (continued)

APPENDIXES	PAGE
A. Simplified Map: CTA to Sibyl Microwave Link.	49
B. Photographs of Site Sibyl	50
C. FCC Docket 19311 Abstract	52

LIST OF ILLUSTRATIONS

	<u>PAGE</u>
1. RDS-80G System.	4
2. Multiplex Bay Functional Diagram.	5
3. Radio Bay Functional Diagram.	7
4. Bit Error Rate vs Received Signal Level Test Configuration.	9
5. Bit Error Rate vs Received Signal Level (back-to-back).	10
6. Bit Error Rate vs Received Signal Level (link).	13
7. Bit Error Rate vs Unavailability.	15
8. Carrier to Interference Test Configuration.	19
9. C/I Characteristic Curves	21
10. Power Spectrum Test Configuration.	22
11. Power Spectrum with FCC Mask	24
12. Data Rate Variation Test Configuration	25
13. T1 Bit Error Rate vs Received Signal Level Test Configuration.	27
14. Bit Error Rate vs Received Signal Level (T1 rate).	29
15. Pulse Jitter Test Configuration A (output/input)	30
16. Pulse Jitter Test Configuration B (20.85 Mb/s rate).	30
17. Pulse Jitter Test Configuration C (output)	30
18. Mean Time to Acquire Frame Test Configuration.	32

LIST OF ILLUSTRATIONS (continued)

	<u>PAGE</u>
19. Cross-Polarization Data Excerpt (1500-6 Dec 74).	37
20. Cross-Polarization Data Excerpt (2040-6 Dec 74).	38
21. Cross-Polarization Data Excerpt (0540-7 Dec 74).	39
22. Cross-Polarization Data Excerpt (0900-7 Dec 74).	40
23. Cross-Polarization Data Excerpt (1140-7 Dec 74).	41
24. Cross-Polarization Data Excerpt (1440-7 Dec 74).	42
25. Cross-Polarization Data Excerpt (0500-8 Dec 74).	43
26. Cross-Polarization Data Excerpt (0720-8 Dec 74).	44
27. Cross-Polarization Data Excerpt (1740-8 Dec 74).	45
28. Cross-Polarization Data Excerpt (0700-8 Dec 74).	46
29. Simplified Map: CTA to Sibyl Microwave Link	49
30. Photograph of Site Sibyl (24 Jan 75)	50
31. Photograph of Site Sibyl (24 Jan 75)	51

1. BACKGROUND.

1.1 Introduction.

1.1.1 This document reports the results of tests performed on engineering models of the Raytheon RDS-80G digital microwave transmission system in back-to-back and active link configurations. This equipment was tested as part of the US Army Communications Command (USACC) Digital Transmission Evaluation Project (DTEP) during the period of 19 August 1974 to 16 December 1974.

1.1.2 By Department of the Army tasking, USACC issued Communications-Electronics Mission Order B74FUS136 in October 1973 to initiate the DTEP. This project contributes to the Army's efforts in the area of commercial development evaluations under DCA Circular 330-195-2.

1.1.3 The US Army Communications Systems Agency (USACSA), Fort Monmouth, New Jersey, is responsible for managing the DTEP. Actual conduct of the tests was delegated to the US Army Electronic Proving Ground (USAEPG), Fort Huachuca, Arizona, under the guidance and supervision of the US Army Communications-Electronics Engineering Installation Agency (USACEEIA), Fort Huachuca, Arizona.

1.2 Approach to the Task.

1.2.1 The tasking documents for the DTEP establish several broad functions of equipment testing to be investigated and determined:

- a. Interface parameters between items of equipment.
- b. Transfer parameters within the system.
- c. Propagation path influences on transfer parameters.
- d. Test techniques and methodology.

1.2.2 To facilitate testing and limit variables, evaluations were scheduled in two phases. The first phase, known as the back-to-back tests, consisted of a series of tests with the equipment in a common location connected by waveguide and cabling. This configuration allowed accurate baseline parameters, test techniques, and performance tests which could not be conducted on an active link with the desired degree of confidence.

1.2.3 The second phase of evaluations was performed on an active link from Fort Huachuca to a repeater site located in Texas Canyon near Benson, Arizona, a distance of approximately 32 miles (51 kilometers). A simplified map is provided in Appendix A.

1.3 Summary of Results and Conclusions.

1.3.1 Plots of bit error rate (BER) versus received signal level (BER) measured in a back-to-back configuration demonstrated that all receivers were performing within the manufacturer's specified tolerances. The attempt to duplicate these curves by artificially fading the transmission over a 32 mile link proved unsatisfactory. This procedure was dismissed as a viable test procedure.

1.3.2 Statistical analysis was employed to determine link availability and increase confidence in data derived from testing. The results of this approach demonstrated a high degree of correlation to anticipated performance, and offers great potential for future evaluations.

1.3.3 The RF spectrum was evaluated to determine the 99 percent power bandwidth and the degree of compliance with FCC Docket 19311 criteria. Analysis indicated that 99 percent of the power was contained in less than 14 MHz, yet the FCC spectrum limitations were exceeded by a small margin.

1.3.4 Errors caused by switching between various back-up components in both automatic and manual modes were recorded confirming compliance with the manufacturer's specifications. The diversity switch created no errors when switching, even when differentially delayed by approximately 40 percent of a bit. This error-less switching is of special importance.

1.3.5 Attempts to interface the RDM-413 time division multiplexer (TDM) with two types of D2 primary multiplexers resulted in modification of the TDM to achieve an operational interface.

1.3.6 Brief measurements of cross-polarized transmission on an active link were performed, showing a relatively high degree of isolation was maintained. Detailed analysis was not completed due to the lack of severe weather conditions, equipment, and time.

1.4 Recommendations.

1.4.1 The statistical sampling techniques employed in tests of this equipment appear to offer great potential in link and system characterization. This technique should be applied to this and other equipments over a longer time frame in order to more precisely define procedures, techniques, and application.

1.4.2 The technique of clock switching employed in the RDM-413 to establish the 1.544 Mb/s rate should be evaluated in a multi-hop configuration to determine advantages or disadvantages of this technique against others on a systems basis.

1.4.3 Variations in T1 channel loading should be performed when measuring BER versus RSL at the 1.544 Mb/s rate to clarify the varying degrees of performance in TDM/radio measurements such as reported in this document.

2. GENERAL.

2.1 Description of Equipment.

2.1.2 Three basic configurations of this equipment are available. Each employs the same basic units, but each is capable of various channel loading.

2.1.2.1 The first configuration offers a 192 voice channel capacity and uses the RDM-408 multiplexer at an output bit rate of 13.13 Mb/s. The radio bay is the RS-842 operating at a 1 b/s per Hz density with 99 percent of the power contained in a 14 MHz bandwidth.

2.1.2.2 The second configuration has a 312 voice channel capacity with the RS-842 radio bay operating at a 1.5 b/s per Hz density. In this configuration, the multiplexer uses the basic frame, is designed for 13 T1 lines, and is named RDM-413. With a multiplexer output bit rate of 20.85 Mb/s, the radio output occupies a 99 percent power bandwidth of 14 MHz or less. This second configuration is the unit tested in the DTEP.

2.1.2.3 The third configuration consists of two RDM-408 multiplexers, each processing 192 voice channels, and two RS-842 radio bays operating on the same RF frequencies. The two radio bays are connected to orthogonally polarized antenna feedhorns for an overall capacity of 384 voice channels in a 14 MHz RF bandwidth.

2.1.3 Figure 2 is a simplified block diagram of the functions performed in the multiplex bay. The input is comprised of 13 circuits of the standard T1 format and bit rate of 1.544 Mb/s in the RDM-413 (eight T1 lines for the RDM-408). For simplicity only one line is detailed in the figure and descriptions refer to the 13 port configuration. The T1 line is converted in the interface card to a format suitable for equipment operations. Additional pulses are added in the stuffer circuitry to build each T1 circuit up to a constant bit rate. The 13 input lines are sequentially sampled and frame pulse sequences and stuff cues added to compose a single bit stream at a nominal 20.85 Mb/s rate. This stream is then applied to the radio transmitter.

2.1.4 In the receive circuitry, the composite 20.85 Mb/s stream is separated into the 13 T1 de-stuffer circuits as the frame sequences are removed. Stuff pulses are removed according to the cueing pulses and the remaining nominal 1.544 Mb/s stream is converted from internal logic to the half-width bipolar T1 format in the interface card for transmission to the first level (PCM) multiplexer.

2.1.5 The 20.85 Mb/s interface between the RDM-413 and the RS-842 is normally in a non-return to zero (NRZ) format when the two bays are located within 50 feet of each other. When the separation

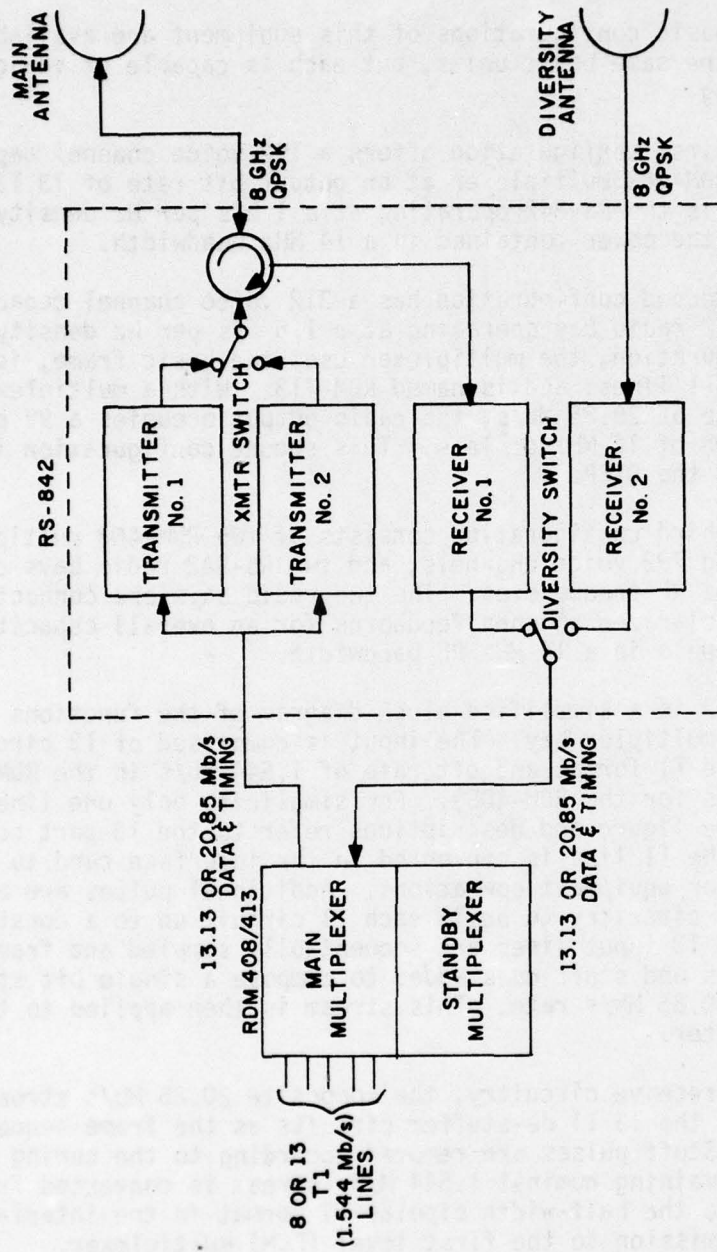

Figure 1. RDS-80G System

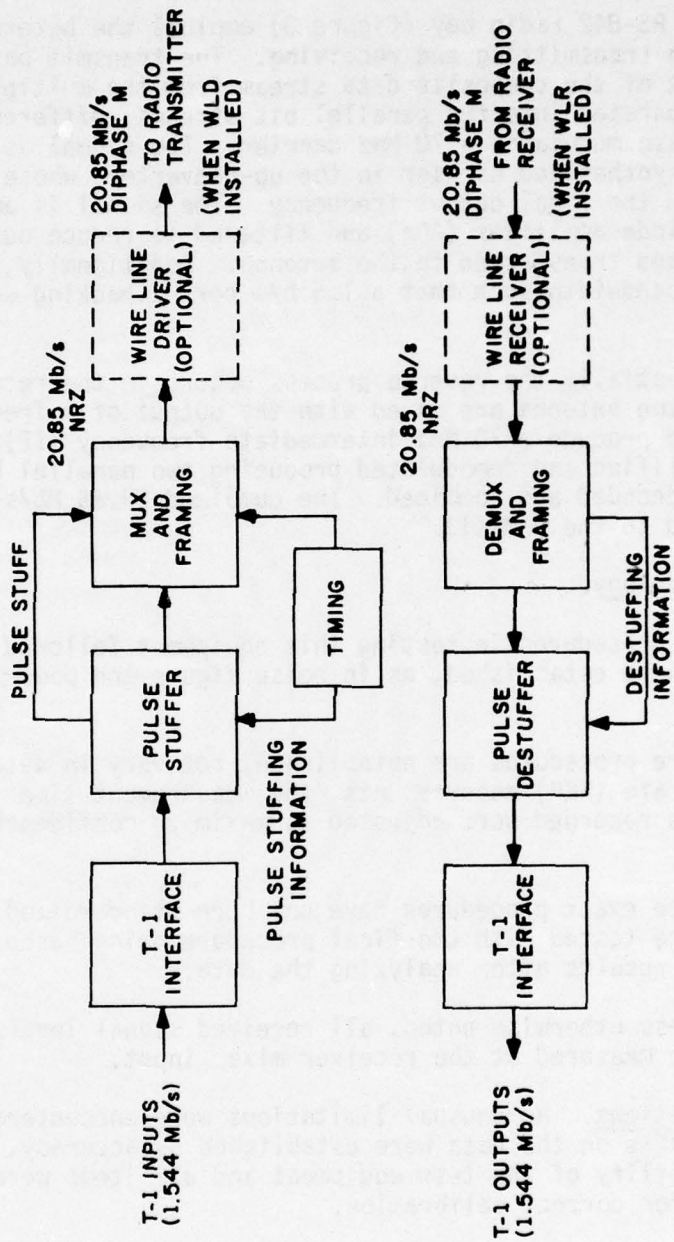

Figure 2. Multiplex Bay Functional Diagram

exceeds 50 feet, optional wire line drivers and receivers are employed which convert the NRZ signals to a Diphase-M format over the intervening cable span.

2.1.6 The RS-842 radio bay (figure 3) employs the heterodyne principle in both transmitting and receiving. The transmit path begins with the receipt of the composite data stream from the multiplex bay. The data is separated into two parallel bit streams, differentially encoded, and phase modulates a 70 MHz carrier. The signal is mixed with a frequency synthesized carrier in the up-converter, whose output is centered on the final output frequency. The signal is amplified in an avalanche diode amplifier (ADA) and filtered to reduce out-of-band emissions and transferred to the antenna. Additionally, the filter restricts bandwidth such that a 1.5 b/s per Hz packing density is achieved.

2.1.7 Essentially the reverse process occurs in the receiver. Signals from the antenna are mixed with the output of a frequency synthesizer to produce a 70 MHz intermediate frequency (IF). The IF signal is amplified and demodulated producing two parallel bit streams which are decoded and combined. The combined 20.85 Mb/s stream is transmitted to the RDM-413.

2.2 Methodology.

2.2.1 The procedures in testing this equipment followed standard practice where established, as in noise figure and power output measurements.

2.2.2 Where procedures are established, but vary in details, as in bit error rate (BER) measurements, the measurement time and number of data points recorded were adjusted to maximize confidence in the results.

2.2.3 Where exact procedures have not been standardized, various methods were tested with the final procedure being based on the validity of the results after analyzing the data.

2.2.4 Unless otherwise noted, all received signal levels (RSL) recorded were measured at the receiver mixer input.

2.3 Limitations. No unusual limitations were encountered in this study. Limits on the data were established by accuracy, stability, and resetability of the test equipment and all items were constantly monitored for correct calibration.

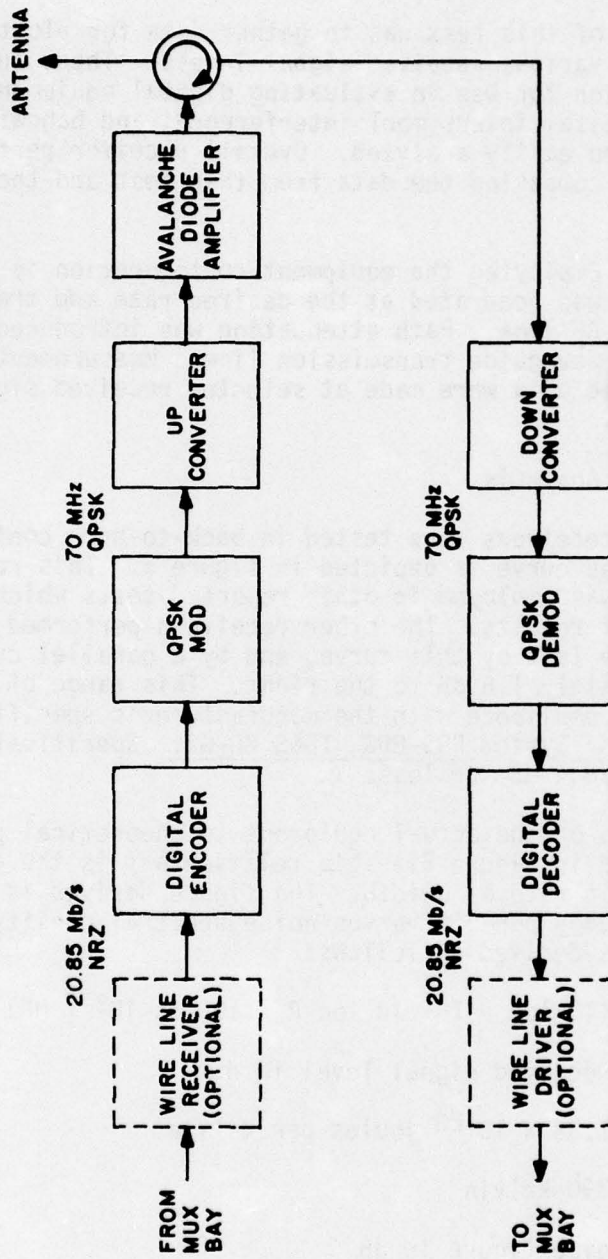

Figure 3. Radio Bay Functional Diagram

3. DETAILS OF TESTS.

3.1 Bit Error Rate vs Received Signal Level.

3.1.1 The purpose of this test was to gather data for plotting bit error rate against various received signal levels. These curves yield important information for use in evaluating digital equipment. Effects of thermal noise, intersymbol interference, and bandwidth are readily apparent and easily analyzed. Overall receiver performance can be analyzed by comparing the data from this test and theoretical predictions.

3.1.2 Procedure. Employing the equipment configuration in figure 4, pseudo-random data was generated at the desired rate and transmitted over the simulated RF link. Path attenuation was introduced with attenuators in the waveguide transmission line. Measurements of errors in the received data were made at selected received signal levels (RSL).

3.1.3 Results and Analysis.

3.1.3.1 All four receivers were tested in back-to-back configuration. For clarity only one curve is depicted in figure 5. This receiver was selected since it was employed in other reported tests which facilitates comparison of results. The other receivers performed in a region bounded on the left by this curve, and by a parallel curve displaced by approximately 1.6 dB to the right. This range of performance demonstrates compliance with the manufacturer's specification for Digital Transmission System RDS-80G, TD&S 80-G2. Specifically, a 10^{-7} BER at an RSL of -75.4 dBm or less.

3.1.3.2 Comparison of the actual equipment to theoretical performance is also illustrated in figure 5. This relationship is the signal-to-noise ratio in a bit rate bandwidth. The figure derived is numerically equal to the energy per bit versus noise spectral density (E_b/N_0). The relationship is derived as follows:

$$E_b/N_0 = \text{RSL} - (10 \log k T + 10 \log R + 10 \log 10^3 + \text{NF})$$

Where: RSL = received signal level in dBm

$$k = 1.38 \times 10^{-23} \text{ joules per kelvin}$$

$$T = 290 \text{ kelvin}$$

NF = noise figure in dB

R = bit rate in bits-per-second

10^3 = correction factor from dBW to dBm

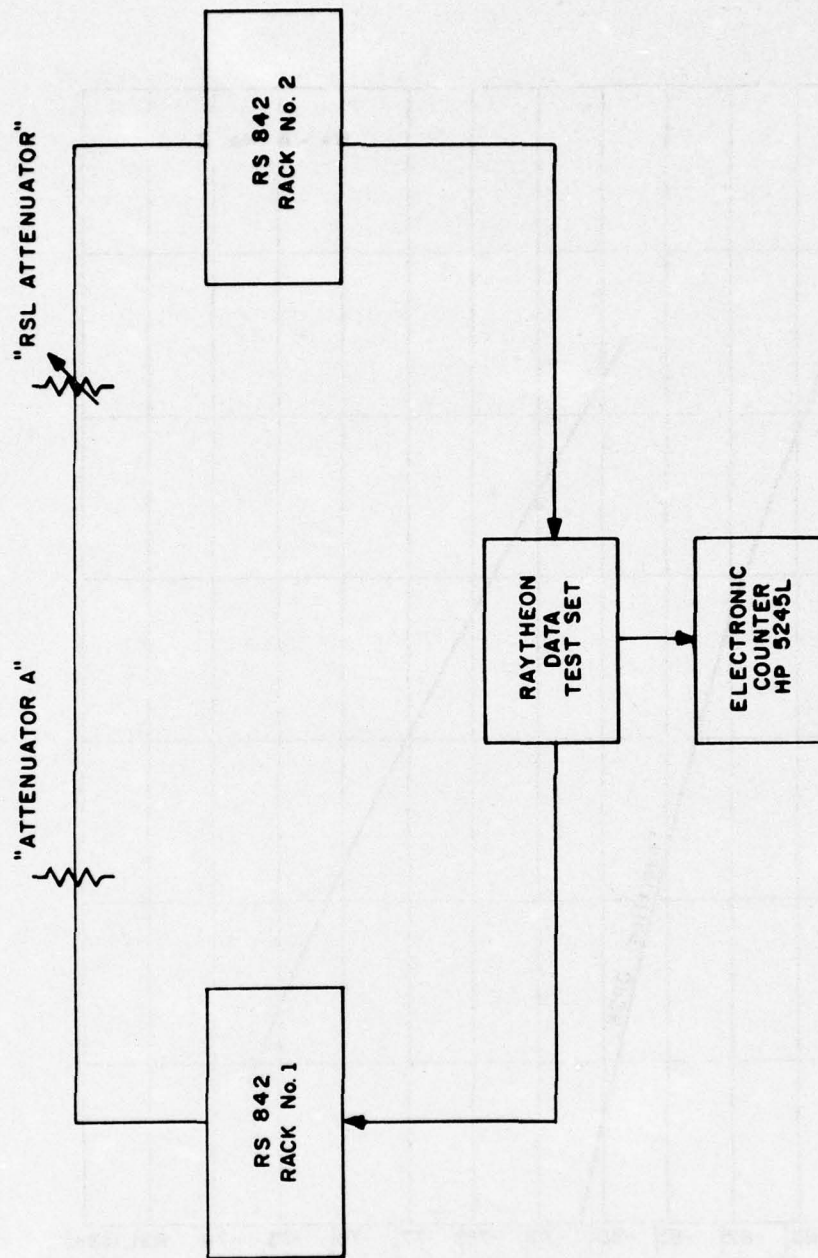

Figure 4. Bit Error Rate vs Received Signal Level Test Configuration

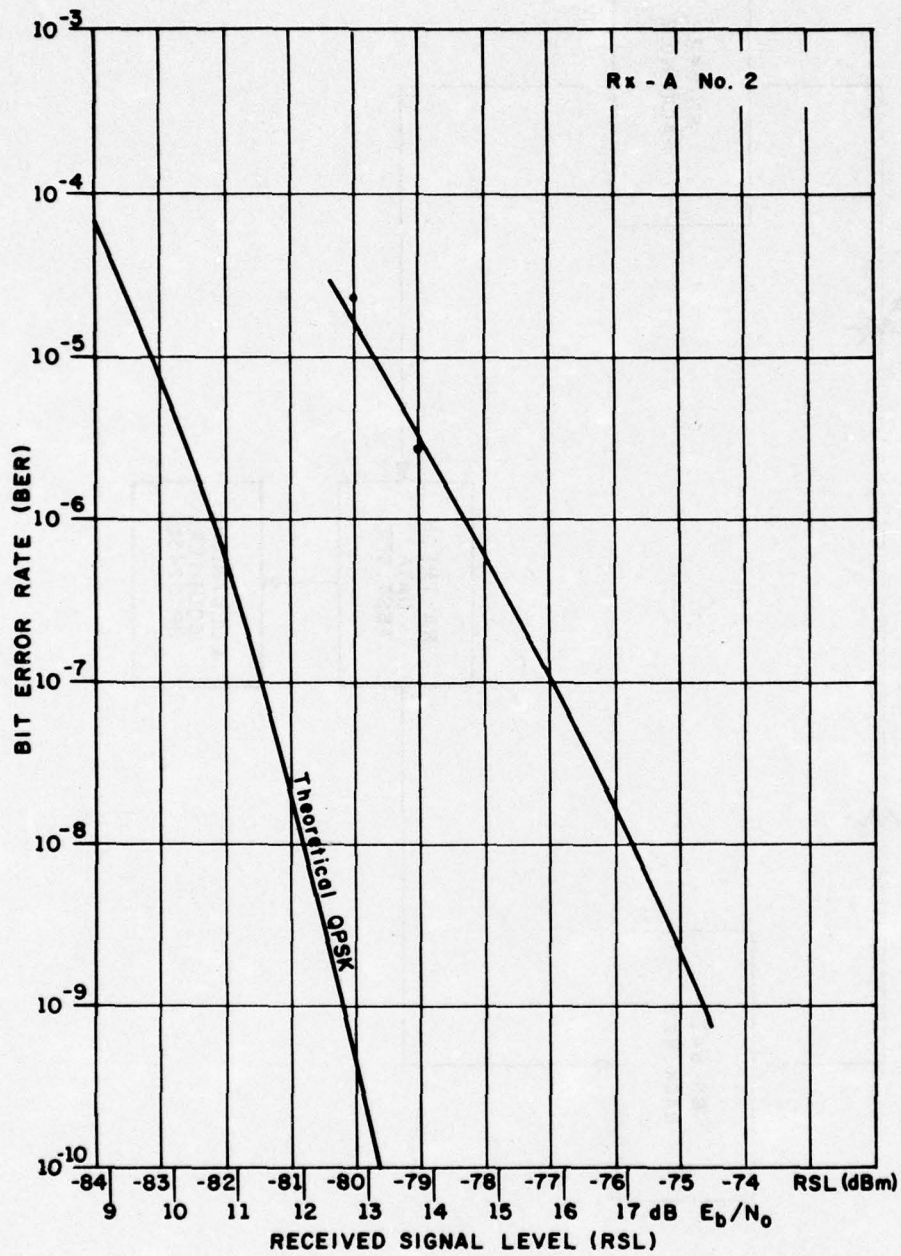

Figure 5. Bit Error Rate vs Received Signal Level (back-to-back)

For example, selecting an RSL of -77 dBm and inserting the noise figure for this receiver of 8.0 dB, the formula yields:

$$E_b/N_0 = -77 - (-174 + 73.2 + 8.0)$$

$$E_b/N_0 = 15.8 \text{ dB}$$

Similarly, this procedure yielded the following results for all four receivers when calculated at 10^{-7} BER threshold

Receiver	NF(dB)	Threshold (dBm)	E_b/N_0	Difference from Theoretical ($E_b/N_0 = 11.4 \text{ dB @ } 10^{-7} \text{ BER}$)
A-1	8.2	-76.4	16.2	4.8
A-2	8.0	-77.0	15.8	4.4
B-1	8.1	-75.6	17.1	5.7
B-2	8.2	-75.6	17.0	5.6

3.1.3.3 The E_b/N_0 value calculated in this manner depends on the system bandwidth being equal to the bit rate. Since the bandwidth of this system is approximately two-thirds of the bit rate, increased degradation is to be expected in the performance of the same equipment when compared to a 1 b/s per Hz configuration.

3.1.3.4 The performance specified by the manufacturer in TD&S 80-G2 (previously cited) lists the 10^{-7} BER thresholds as -75.4 dBm for 20.85 Mb/s and -78.3 dBm for 13.13 Mb/s. Referring to the formula in 3.1.3.2, the change in bit rates would constitute only a 2.0 dB change in the threshold. The additional 0.9 dB degradation in specified performance is attributable to distortion effects caused by filtering. Some of these effects are outlined in the October 1974 issue of the IEEE Transactions on Communications, Volume COM-22, No. 10, in an article titled "The Effect of Tandem Band and Amplitude Limiting on the E_b/N_0 Performance of Minimum (Frequency) Shift Keying (MSK)," by H. Robert Mathwich.

3.2 Link Characterization.

3.2.1 The objective of this test was to verify the BER vs RSL performance measured in back-to-back tests, and ascertain the effects of the transmission path on the data.

3.2.2 Procedure.

3.2.2.1 With the RF link activated, receivers and transmitters were selected in discrete pairs with eight possible combinations among the two transmitters and two receivers at each site.

3.2.2.2 Having selected the transmitter/receiver pair to be tested, attenuation was introduced in the waveguide transmission line to reduce the RSL to a desired value in the threshold region, and BER measurements were made.

3.2.2.3 Received signal level data was obtained by constantly monitoring a strip-chart recorder which displayed IF signal level calibrated to values of RSL. Recorded values were averaged for the duration of each measurement.

3.2.2.4 Equipment limitations dictated that attenuation be controlled from the Communications Test Area (CTA), Fort Huachuca terminal only, such that when receiver measurements were made at CTA, the received signal strength was varied, and for transmission to the Site Sibyl, the transmit power was adjusted.

3.2.3 Results and Analysis.

3.2.3.1 This technique was discarded as a viable test procedure due to the difficulty in adequately determining the mean RSL during tests resulting in wide variability in results.

3.2.3.2 Equipment failures attributed to wide thermal variations in the repeater van restricted the available equipment combinations for this test. Of the two combinations tested in the direction of the Site Sibyl repeater to the CTA at Fort Huachuca, both were discarded when it was discovered that the excessive temperature variations adversely affected the transmitter circuitry. Subsequently, ambient temperatures were maintained nearly constant. One combination was tested by transmitting in the opposite direction.

3.2.3.3 The results of the measurements employing the main transmitter at the CTA and the receiver no. 1 at Site Sibyl are displayed in figure 6. Wide scattering was observed with pronounced differences existing among data taken on two successive days. At this point the technique was abandoned and other procedures were explored (paragraph 3.3).

3.3 Link Bit Error Rate Availability.

3.3.1 The objective of this analysis was to determine the time availability of a specified BER performance level.

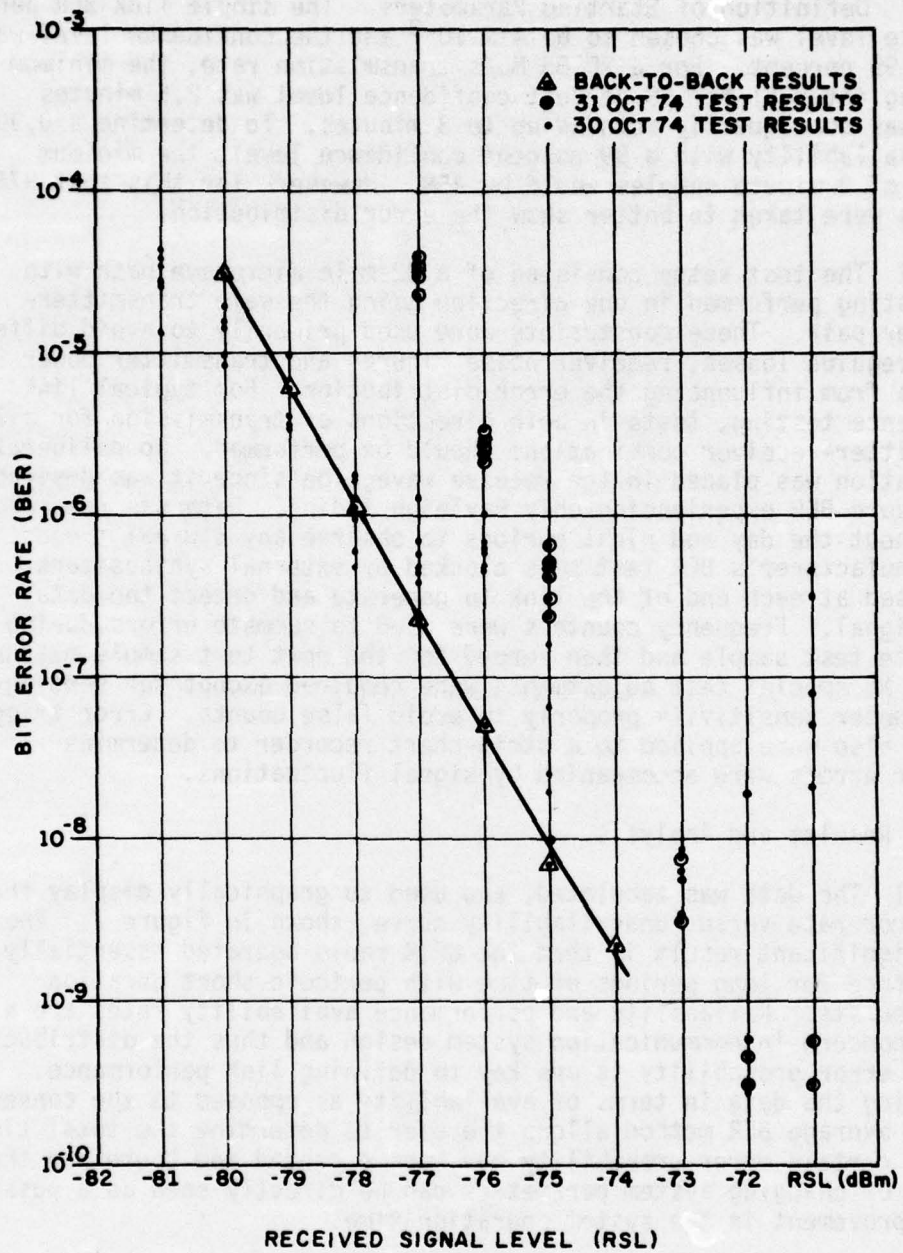

Figure 6. Bit Error Rate vs Received Signal Level (link)

3.3.2 Procedure.

3.3.2.1 Definition of Starting Parameters. The single link BER performance level was chosen to be 4×10^{-9} and the confidence level was set at 99 percent. For a 20.85 Mb/s transmission rate, the minimum sampling interval for 99 percent confidence level was 2.5 minutes which was subsequently rounded up to 3 minutes. To determine a 0.99 time availability with a 99 percent confidence level, the minimum number of 3 minute samples would be 458. However, for this test 976 samples were taken to better show the error distribution.

3.3.2.2 The test setup consisted of a 32 mile microwave path with all testing performed in one direction using the same transmitter-receiver pair. These constraints were used primarily to avoid different waveguide losses, receiver noise figures and transmitter power outputs from influencing the error distribution. For typical link acceptance testing, tests in both directions of transmission for all transmitter-receiver combinations should be performed. No deliberate attenuation was placed in the receive waveguide since it was desirable to measure BER experiencing only Rayleigh fading. Data was recorded throughout the day and night periods to observe any diurnal trends. The manufacturer's BER test sets clocked by external synthesizers were used at each end of the link to generate and detect the data test signal. Frequency counters were used to summate errors during a 3 minute test sample and then zeroed for the next test sample measurement. No special test adjustments were required except for setting the counter sensitivity properly to avoid false counts. Error trigger pulses also were applied to a strip-chart recorder to determine whether errors were accompanied by signal fluctuations.

3.3.3 Results and Analysis.

3.3.3.1 The data was tabulated, and used to graphically display the bit error rate versus unavailability curve, shown in figure 7. The most significant result is that the QPSK radio operated essentially error free for long periods of time with periodic short duration error bursts. Reliability and performance availability rates are a major concern in communication system design and thus the distribution of the error probability is one key to defining link performance. Analyzing the data in terms of availability as opposed to the conventional average BER method allows the user to determine the total time that a certain error probability has been exceeded and therefore the effect of changing system parameters can be directly seen as a possible improvement in the system operation time.

3.3.3.2 The following table shows that 930 of the 976 three minute samples were error free and that error free operation was maintained 95.19 percent of the test time. The planned performance objective of 4×10^{-9} BER was maintained 98.36 percent of the time. To demonstrate an availability of 99.995 percent at a confidence level of 99 percent

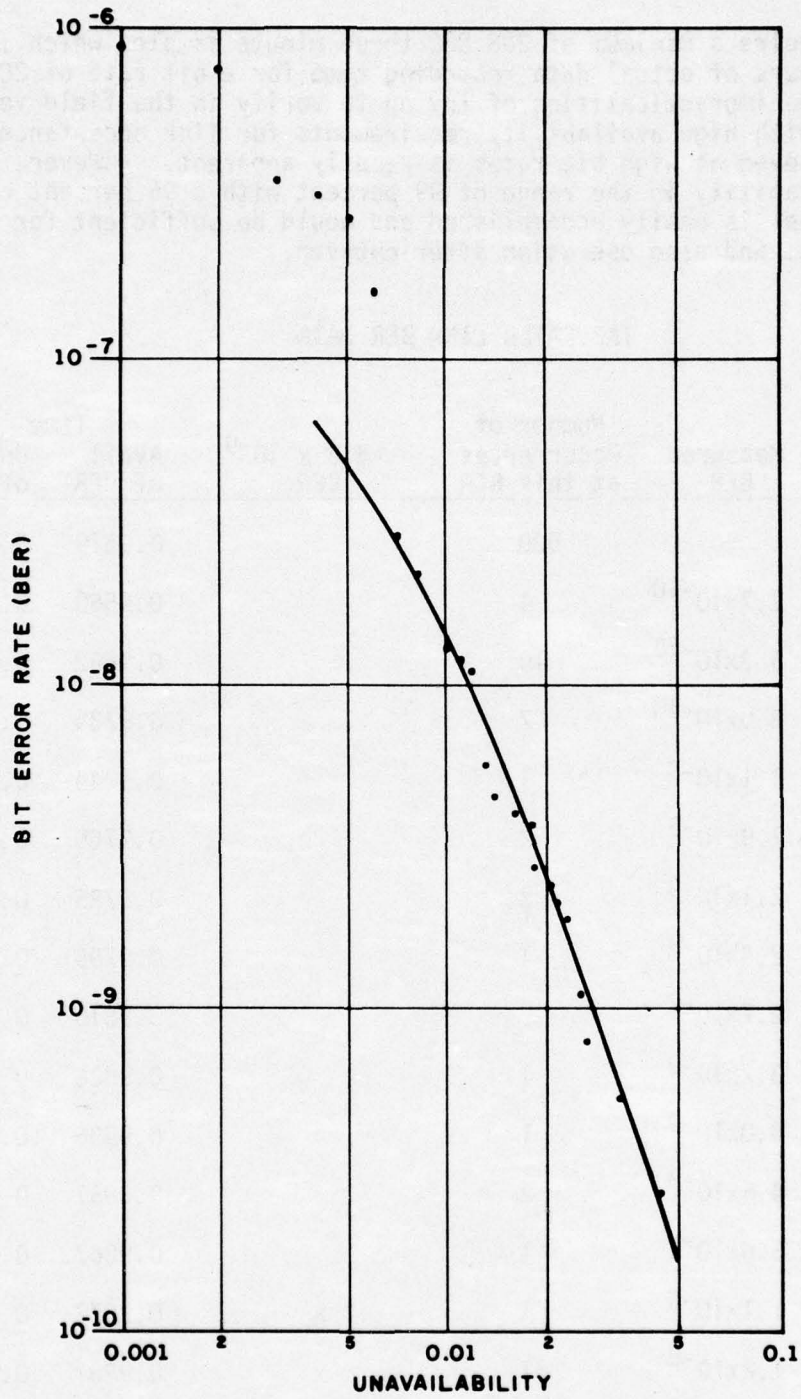

Figure 7. Bit Error Rate vs Unavailability

would require a minimum of 208,883 three minute samples which is 10,444 hours of actual data recording time for a bit rate of 20.85 Mb/s. The impracticalities of trying to verify in the field very low BER with high availability requirements for link acceptance purposes even at high bit rates is readily apparent. However, measuring availability in the range of 99 percent with a 95 percent confidence level is easily accomplished and would be sufficient for link acceptance and also operation after cutover.

TABULATED LINK BER DATA

Number of Errors	Measured BER	Number of Occurrences at this BER	>8.8 x 10 ⁻⁹ BER	Time	
				Avail of BER	Unavail of BER
0		930		0.9519	0.0481
1	2.7x10 ⁻¹⁰	4		0.9560	0.0440
2	5.3x10 ⁻¹⁰	10		0.9662	0.0338
3	8.0x10 ⁻¹⁰	7		0.9734	0.0266
4	1.1x10 ⁻⁹	1		0.9744	0.0256
7	1.9x10 ⁻⁹	2		0.9765	0.0235
8	2.1x10 ⁻⁹	2		0.9785	0.0215
9	2.4x10 ⁻⁹	1		0.9795	0.0205
10	2.7x10 ⁻⁹	2		0.9816	0.0184
14	3.7x10 ⁻⁹	1		0.9826	0.0174
15	4.0x10 ⁻⁹	1		0.9836	0.0164
17	4.5x10 ⁻⁹	2		0.9857	0.0143
21	5.6x10 ⁻⁹	1		0.9867	0.0133
43	1.1x10 ⁻⁸	1	x	0.9877	0.0123
45	1.2x10 ⁻⁸	1	x	0.9887	0.0113
47	1.3x10 ⁻⁸	1	x	0.9898	0.0102
82	2.2x10 ⁻⁸	1	x	0.9918	0.0082
83	2.2x10 ⁻⁸	1	x	0.9918	0.0082

TABULATED LINK BER DATA (continued)

Number of Errors	Measured BER	Number of Occurrences at this BER	>8.8 x 10 ⁻⁹ BER	Time	
				Avail of BER	Unavail of BER
108	2.9x10 ⁻⁸	1	x	0.9928	0.0072
596	1.6x10 ⁻⁷	1	x	0.9939	0.0061
1000	2.7x10 ⁻⁷	1	x	0.9949	0.0051
1217	3.2x10 ⁻⁷	1	x	0.9959	0.0041
1305	3.5x10 ⁻⁷	1	x	0.9969	0.0031
2928	7.8x10 ⁻⁷	1	x	0.9980	0.0020
3369	9.0x10 ⁻⁷	1	x	0.9990	0.0010

Total Samples: 976

Total Test Time: 2928 minutes

Total Errors: 11,015

3.3.3.3 With any performance measurement there must be a performance objective and there should be an allowable tolerance boundary around the objective. This is very true for BER link measurements since the BER does not remain a fixed value because of the numerous dynamic impairments that co-exist in the system. For the purpose of this test, with a 4×10^{-9} BER as the objective, the 99 percent confidence upper bound was calculated to be 8.8×10^{-9} . Thus, for any BER measured that is better than 8.8×10^{-9} there is 99 percent confidence that at least an overall 4×10^{-9} is being delivered.

3.3.3.4 The measured data shows there were 12 occasions when a 8.8×10^{-9} was not maintained in a 3-minute test block. However, the worst test block still supported a BER of 9×10^{-7} . Experience from the CTA to Site Sibyl link has shown repeatedly that error bursts are generally 100 or less errors.

3.3.3.5 Figure 7 is a graph of BER plotted against percent of time of unavailability. One problem of BER measurements is the case where zero errors are recorded and thus division of zero by the number of bits transmitted to calculate BER is impossible. Since zero error is less than one real error, the BER is conventionally said to be less than the BER calculated from one error. However, zero error for a given transmission rate and sampling

time does represent a real BER. From the data table a 2.7×10^{-10} BER is supported 95.60 percent of the time and an unknown BER is supported 95.19 percent of the time. By extending the curve of figure 7, the 0.0481 unavailability axis indicates a BER of 1.9×10^{-10} . Thus, if zero errors were recorded in a 3-minute period at a rate of 20.85 Mb/s, the BER in that period would be 1.9×10^{-10} . The spread between 1.9×10^{-10} (0 error) and 2.7×10^{-10} (1 error) may not intuitively be great enough, yet it must be remembered that the difference between no error and 1 bit in error out of 3.8 billion bits is very small.

3.3.3.6 Figure 7 shows an apparent discontinuity in the curve. However, the problem lies in the fact there is a large increase in the number of errors counted for a one step change in number of events at the high end of the availability data. For example, in the table there was one event of a 596 error burst and one event of a 1,000 error burst. This means that for 99.39 percent of the time there were 596 or less errors in a 3-minute test period, and for 99.49 percent of the time there were 1,000 or less errors in a 3-minute test period. Yet between the 99.49 percent availability and 99.39 percent availability, there were also 999 or less errors, 998 or less, 997 or less, on down to 598 or less, 597 or less errors, etc. Had each of these error counts occurred at least once, the plot would have been a smooth, continuous curve.

3.3.3.7 A point of interest is the comparison of the 1.9×10^{-10} BER supported for 95.19 percent of the time against the average BER over the entire test time. A total of 11,015 errors was recorded over a total test time of 2,928 minutes, giving an average BER of 3.0×10^{-9} . Thus, a few large error bursts can give a false indication of an otherwise essentially error free system.

3.4 Carrier-to-Interference (C/I) Ratio.

3.4.1 The purpose of this test was to gather data in a controlled environment (back-to-back) for plotting bit error rate against various received signal levels for five cases of added interference. These curves yield results necessary for the study of electromagnetic compatibility (EMC), and isolation between orthogonal planes of polarization as well as isolation among other systems in close geographic and spectral proximity.

3.4.2 Procedure. The test procedure included measuring data for C/I ratios of 12 dB, 15 dB, 18 dB, 21 dB, and 24 dB, as well as the no-interference case. The equipment was connected as illustrated in figure 8. Calibration was conducted by setting the "RSL Attenuator" to zero and varying the "Interference Attenuator" to adjust the C/I level. A zero interference level was combined with a

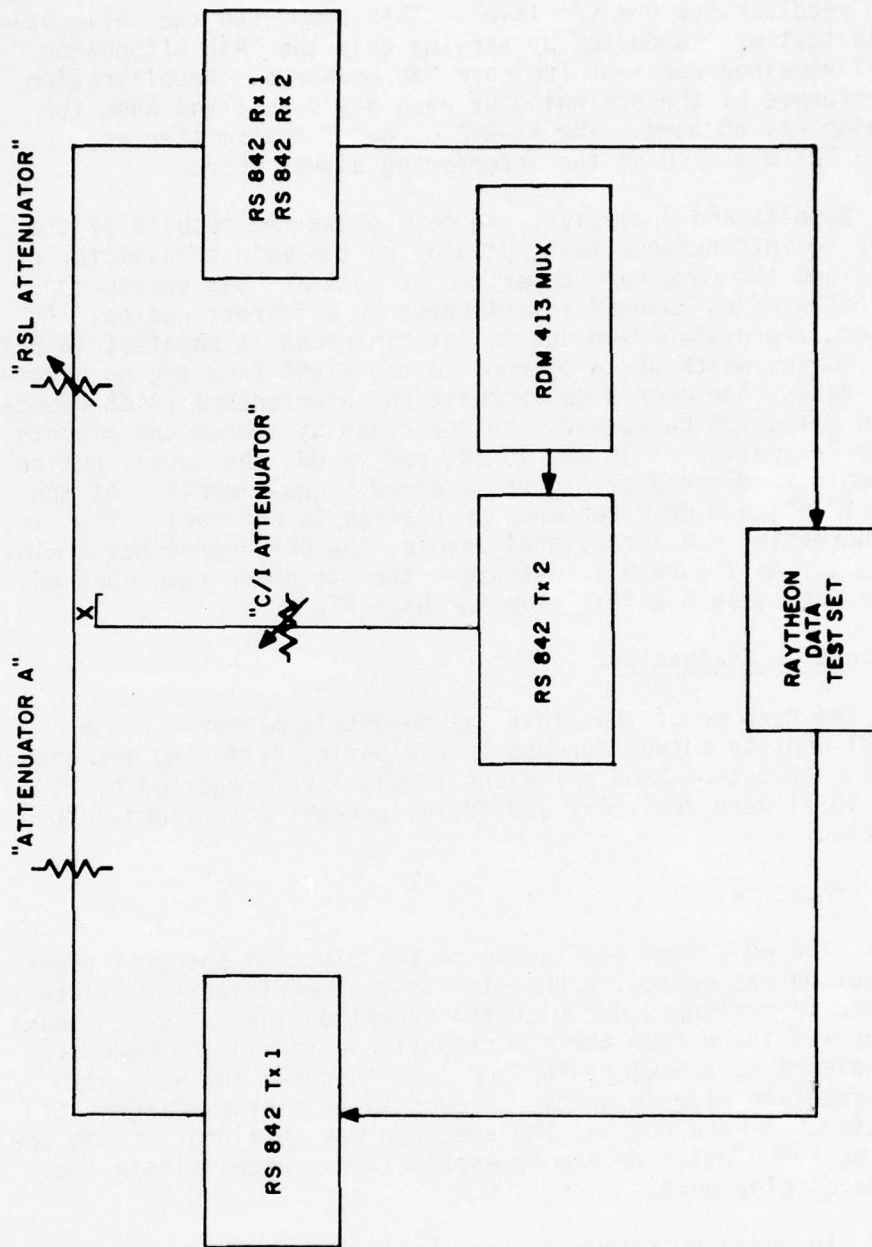

Figure 8. Carrier to Interference Test Configuration

steady transmitter signal and the power was measured at the receiver mixer. Then the transmitter was disabled and the "Interference Attenuator" was adjusted for the appropriate power reading at the receiver for one C/I level. This completed the calibration and the test was conducted by varying only the "RSL Attenuator." The C/I remained constant for each RSL measured. Recalibration was performed at the beginning of each day's test and when the waveguide was changed. The RS-842 number 2 transmitter and RDM-413 TDM was used at the interfering signal source.

3.4.3 Results and Analysis. Figure 9 shows the results of the carrier to interference test, displaying the main transmitter of rack B, and the receiver number two of rack A. Six curves show the effects of co-channel interference in different ratios. As expected, the degradation due to interferences is manifest in BER vs RSL curves which are displaced to the right from the no interfering case. For each 3 dB increase in interference (3 dB reduction in C/I), the curve moves to the right by increasing amounts. For the C/I ratios of 18 dB, 15 dB, and 12 dB, the curves noticeably begin to diverge at higher received signal levels. At the C/I of 12 dB, a wide divergence or plateau is apparent. That is, with increasing received signal levels, the BER approaches a minimum limit. As figure 9 illustrates, the bit error rate does not improve more than 5×10^{-5} even for high RSL's.

3.5 Spectrum Evaluation.

3.5.1 The purpose of this test was to obtain measured power spectral density curves for use in evaluating filtering techniques. Rejection of out-of-band emissions to the level required by FCC Docket 19311 were analyzed, and the 99 percent power bandwidths calculated.

3.5.2 Procedure.

3.5.2.1 The equipment configuration for plotting spectral power distribution was basically the same as that employed for C/I testing described in section 3.4.2 with the exception that a small amount of power was taken from the directional coupler in the waveguide and displayed on a Hewlett-Packard 141T spectrum analyzer with the appropriate plug-in units. Figure 10 is a block diagram of the system. A hard copy of the spectrum was obtained through the use of an X-Y plotter driven by appropriate sources within the analyzer display unit.

3.5.2.2 In order to reference the displayed spectrum accurately to the appropriate FCC Docket 19311 requirements, total radiated power measurements of both modulated and unmodulated carriers also were made employing a Boonton 42 AD power meter with a 41-4B power sensor.

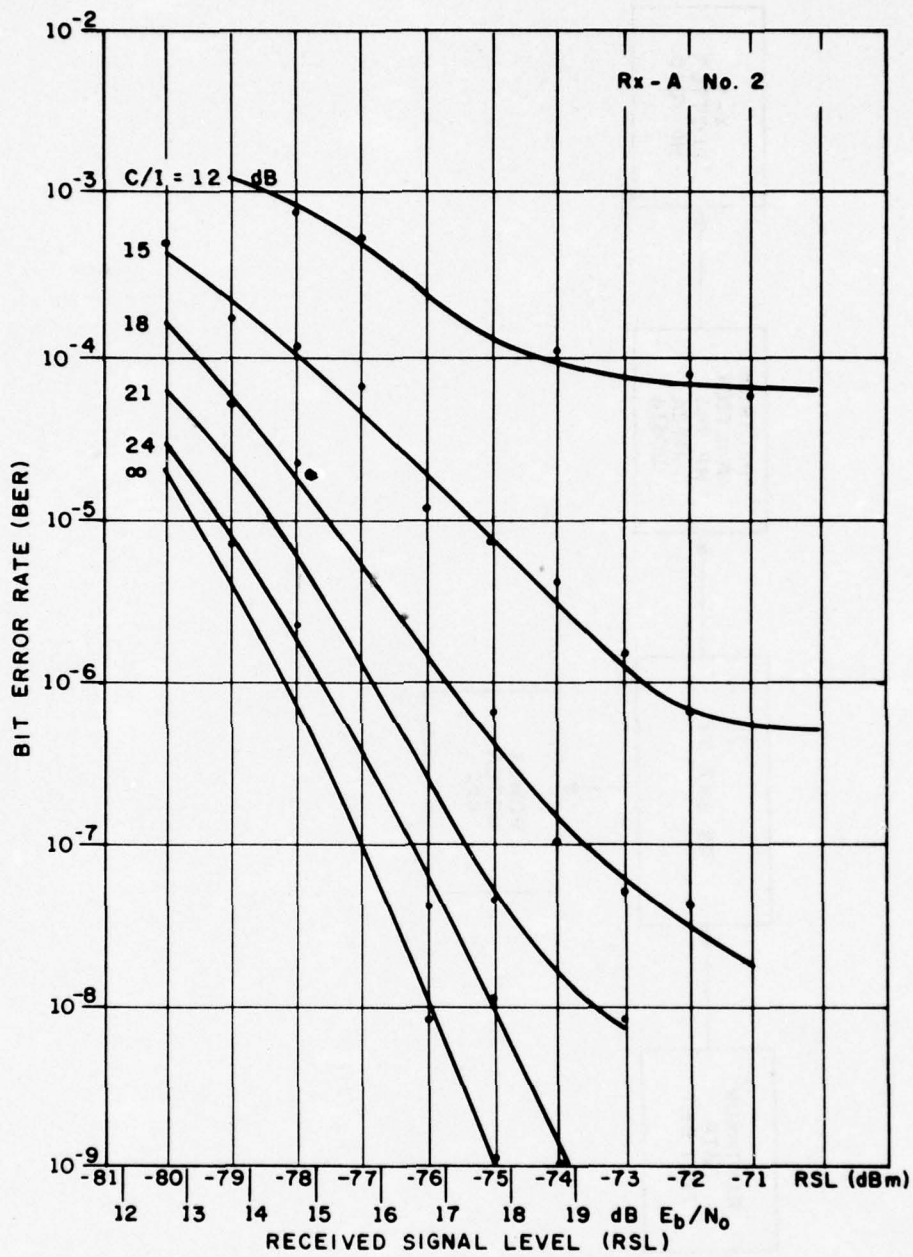

Figure 9. C/I Characteristic Curves

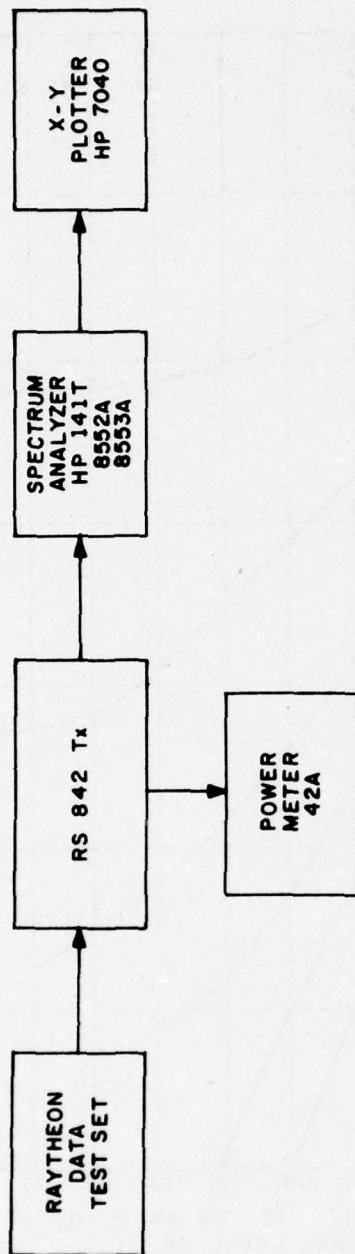

Figure 10. Power Spectrum Test Configuration

3.5.3 Results and Analysis.

3.5.3.1 Close correlation was observed among all transmitted spectra. The median curve is illustrated in figure 11. The major differences were in the energy densities of the sidebands which amounted to approximately 2 dB at their peaks. Integration of the spectrums revealed negligible effects due to power density variations.

3.5.3.2 Manual integration of the spectrum was performed in 0.5 MHz increments. Resulting values were then equated to the +27.2 dBm measured power output, allowing application of the FCC Docket 19311 emission criteria as well as calculation of the 99 percent power bandwidth.

3.5.3.3 The 99 percent power bandwidth was determined to be 13.2 MHz. According to older standards, this indicates that the system is suitable for operation in a 14 MHz RF channel. The FCC Docket 19311 limitations superimposed on the spectrum in figure 11 demonstrate that the transmitter does not comply with the newer criteria failing by a small margin. Slightly increased attenuation of the RF filter skirts of about 2 dB at $f_c \pm 7$ MHz and 6-7 dB at $f_c \pm 12$ MHz should result in compliance with the Docket 19311 limitations.

3.6 Data Rate Variations.

3.6.1 The purpose of this test was to establish variations in system performance as a function of the baseband bit rate. The data rates were varied above and below the 1.544 Mb/s nominal rate until the system ceased operation. The data derived from this test may be used to determine the required stability within the multiplex hierarchy.

3.6.2 Method. The test equipment used to measure effects of data rate variation is illustrated in figure 12. An external synthesizer clocks the data test set which drives the RDM413 multiplexer. The signal is multiplexed, looped back, demultiplexed, and then measured by the data test set. Errors were monitored on the electronic counter. The point of last synchronization determined the maximum deviation in data rate.

3.6.3 Results and Analysis. The manufacturer's stated requirements were no degradation for a nominal 1.544 Mb/s with all channels loaded and a tolerance of +200 b/s and a -309 b/s. This range is from 1.543691 Mb/s to 1.544200 Mb/s. While the actual test was conducted on every main and standby multiplexer and demultiplexer channel, only one channel was loaded at one time. This technique is different from that specified by the manufacturer. The data reveals that the manufacturer's tolerances were met for no degradation in performances. The actual variation from the normal rate

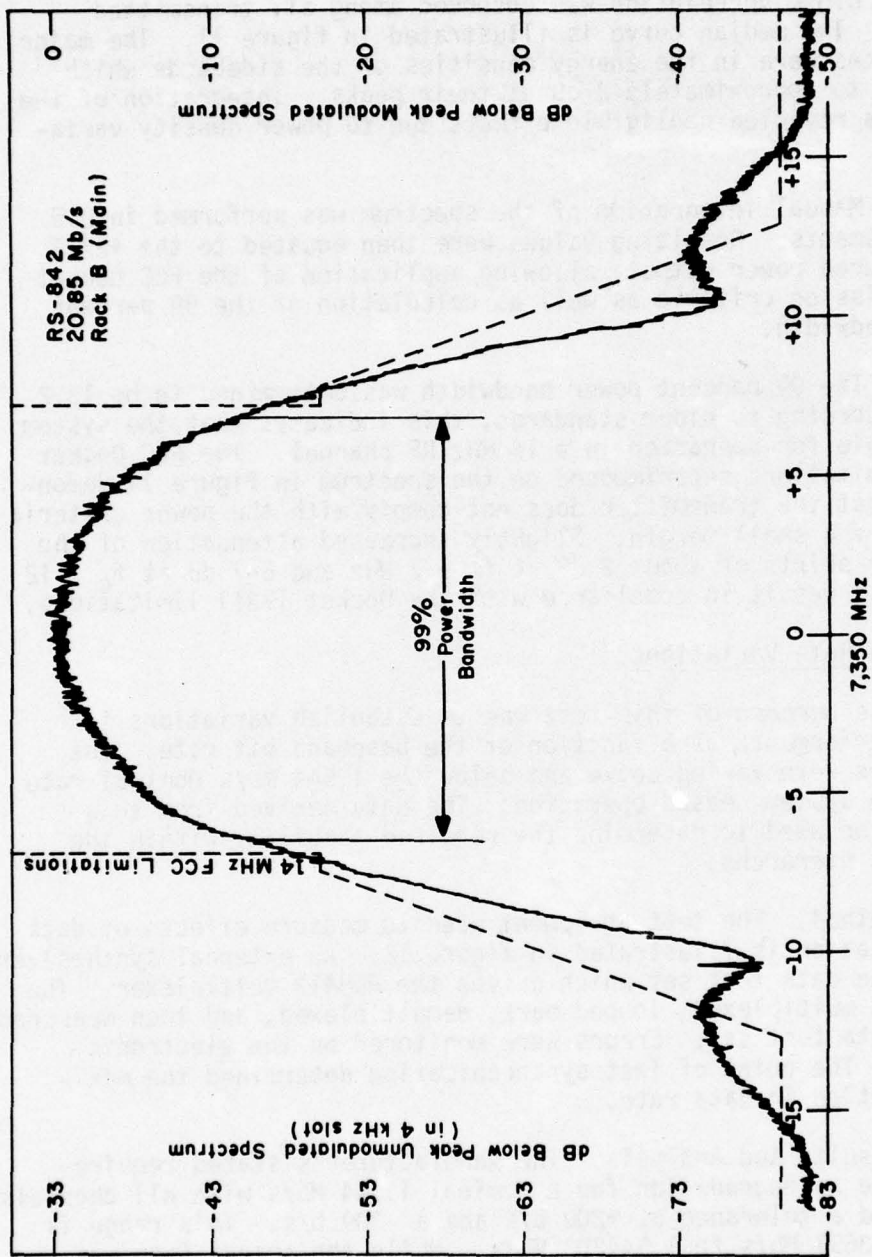

Figure 11. Power Spectrum with FCC Mask

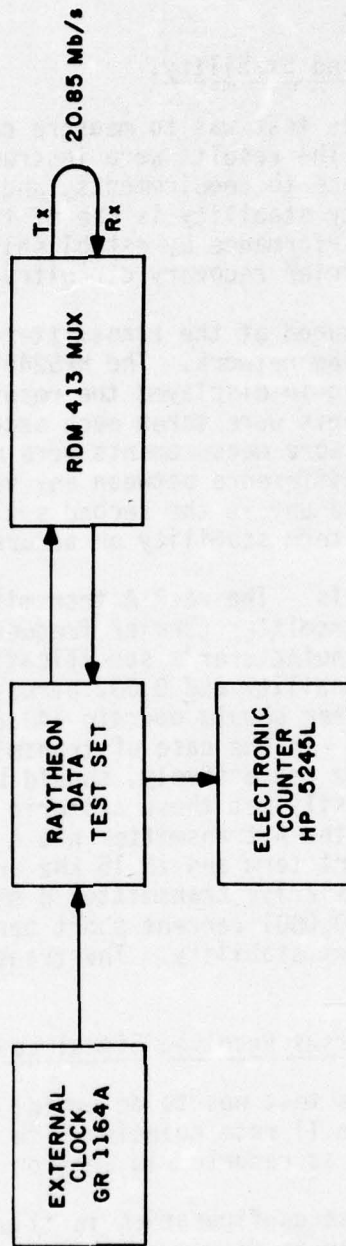

Figure 12. Data Rate Variation Test Configuration

was +250 b/s and -350 b/s which corresponds to a range of 1.543650 Mb/s to 1.544250 Mb/s. At these points, the channel totally degraded. Observations of jitter showed no measurable change with the variation of T1 rate.

3.7 Frequency Accuracy and Stability.

3.7.1 The purpose of this test was to measure carrier frequency accuracy and stability. The results were instrumental in determining degree of compliance to requirements, and to manufacturer's specifications. Frequency stability is one of the factors which determine the receiver performance by establishing the tracking range required by the carrier recovery circuitry.

3.7.2 Frequency was measured at the transmitter monitor point located at the RF branching network. The HP5245L Electronic Counter with 5255A RF plug-in displayed the results. For short term stability, measurements were taken each second for 10 seconds. Then, after 90 hours, 10 more measurements were made at one second intervals. The maximum difference between any value in the first set of 10 measurements and any in the second set of 10 measurements was recorded as the long term stability or accuracy.

3.7.3 Results and Analysis. The rack A transmitter was tuned to 8.16 GHz and the B transmitter carrier frequency was 7.35 GHz. Therefore, to meet the manufacturer's specifications of 0.0005 percent/sec short term stability and 0.002 percent long term stability, the A transmitter should operate ± 40.8 kHz short term, and ± 163.2 kHz long term. In the case of transmitter B, tolerances of ± 36.8 kHz and 147.3 kHz respectively, should be met. In the test, the transmitters easily met these criteria and for the worst case of main or standby, the A transmitter had a variation of 9.37 kHz or 0.0001 percent short term and 15.15 kHz or 0.0002 percent long term stability. Similarly, transmitter B showed a maximum variation of 9.15 kHz or 0.0001 percent short term and 15.92 kHz or 0.0002 percent long term stability. The transmitters proved to be quite stable.

3.8 T1 Bit Error Rate Versus Received Signal Level.

3.8.1 The purpose of this test was to determine if the BER vs RSL characteristics at the T1 rate coincide with the wideband BER vs RSL characteristic as reported in section 3.1.

3.8.2 Procedure. The test configuration is illustrated in figure 13. The RDM413 multiplexer is driven by the data test set at 1.544 Mb/s. The signal is accepted by the RS842, transmitted to the receiver which interfaces with the demultiplexer. The data test set evaluates the signal and the electronic counter displays errors. Simulated path attenuation was employed by using a combination of fixed and variable waveguide attenuators.

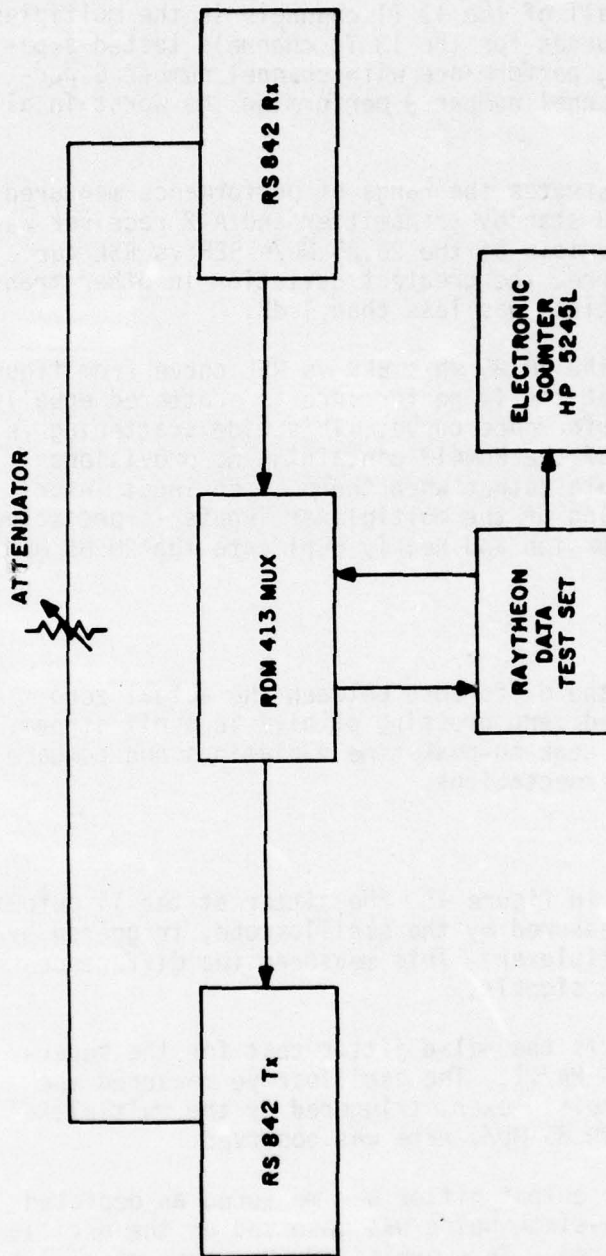

Figure 13. T1 Bit Error Rate vs Received Signal Level Test Configuration

3.8.3 Results and Analysis.

3.8.3.1 Equipment limitations did not permit applying independent random data streams on all of the 13 T1 channels in the multiplex. Therefore, BER vs RSL curves for the 13 T1 channels tested separately exhibited varying performance with channel number 6 performing the best and channel number 3 performing the worst in all combinations tested.

3.8.3.2 Figure 14 illustrates the range of performance measured. The combination of the B standby transmitter and A-2 receiver was selected to enable comparison of the 20.85 Mb/s BER vs RSL curve in figure 14. Furthermore, the greatest deviation in other transmitter-receiver combinations was less than 1 dB.

3.8.3.3 Superimposing the 20.85 Mb/s BER vs RSL curve from figure 6 on figure 14 shows that the T1 performance is scattered equally about the 20.85 Mb/s performance curve. This wide scattering is thought to be a result of the RDM413 containing no provisions for "randomizing" the data output when there is no input information. Increased loading of the multiplexer inputs is predicted to narrow the data dispersion and nearly duplicate the 20.85 Mb/s performance.

3.9 Pulse Jitter.

3.9.1 Pulse jitter is the difference between the actual zero crossing and the expected zero crossing of bits in a bit stream. The test was to measure peak-to-peak time variations and compare them to manufacturer's expectations.

3.9.2 Procedure.

3.9.2.1 As illustrated in figure 15, the jitter at the T1 output rate (1.544 Mb/s) was measured by the oscilloscope, triggered by the T1 input to the multiplexer. This measured the difference between input and output signals.

3.9.2.2 Figure 16 depicts the pulse jitter test for the super-group signal rate (20.85 Mb/s). The oscilloscope measured the transmit output of the multiplexer, triggered by the multiplexer timing. Jitter at the 20.85 Mb/s rate was observed.

3.9.2.3 The multiplexer output jitter was measured as depicted in figure 17. The fifty-sixth pulse was observed on the oscilloscope, internally triggered. This exhibited the worst case jitter of the multiplexer output alone.

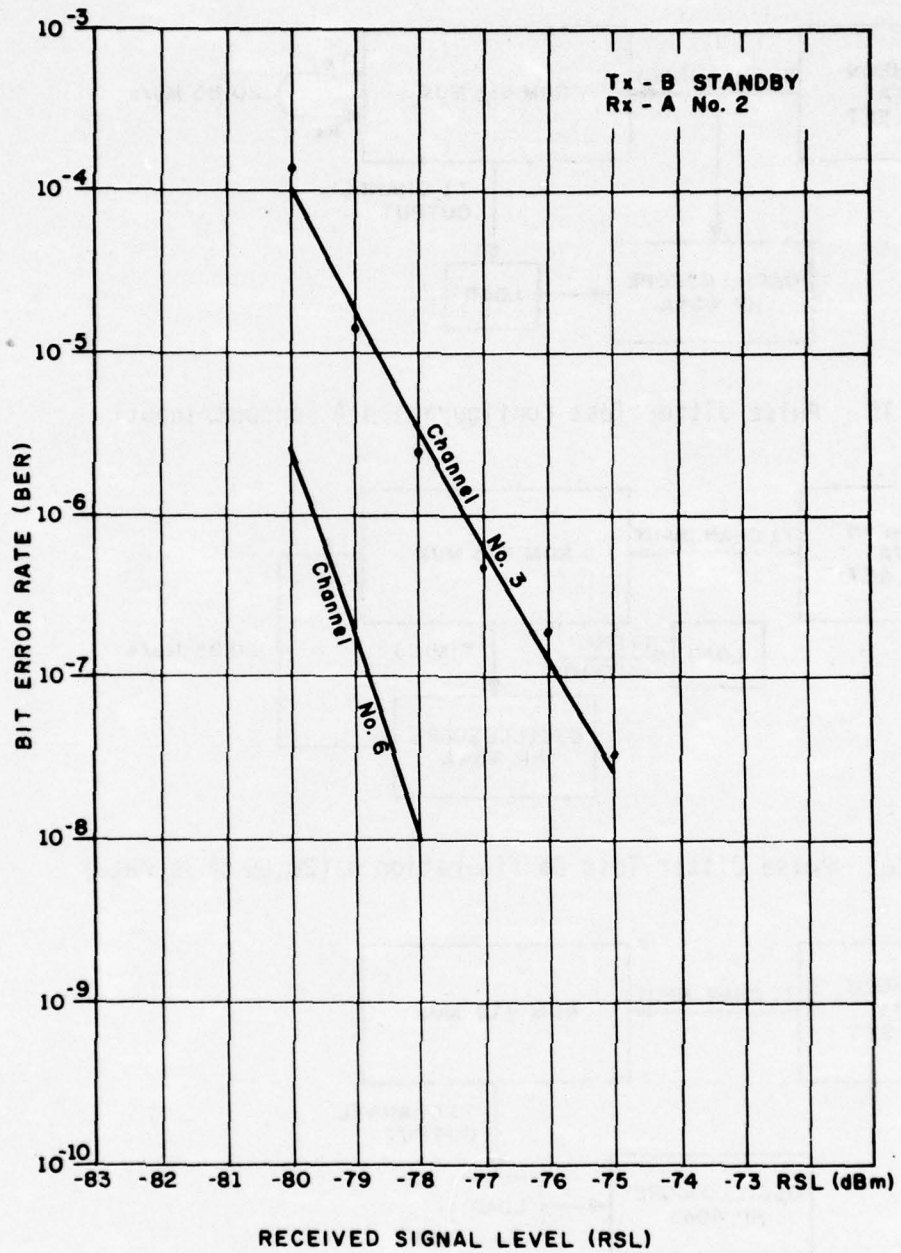

Figure 14. Bit Error Rate vs Received Signal Level (T1 rate)

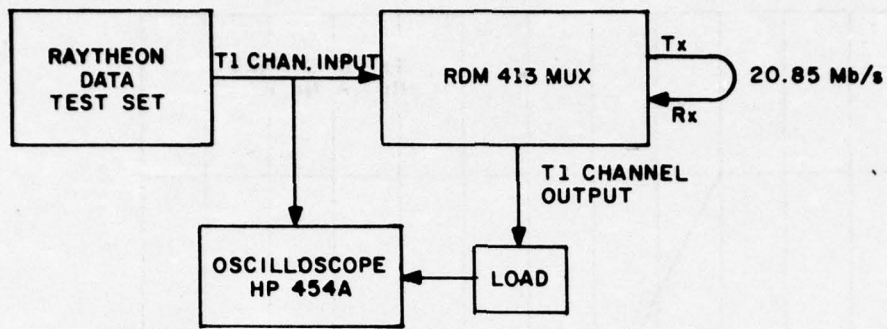

Figure 15. Pulse Jitter Test Configuration A (output/input)

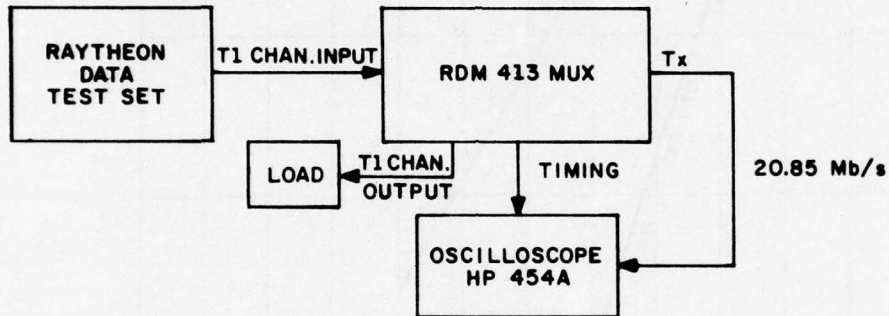

Figure 16. Pulse Jitter Test Configuration B (20.85 Mb/s rate)

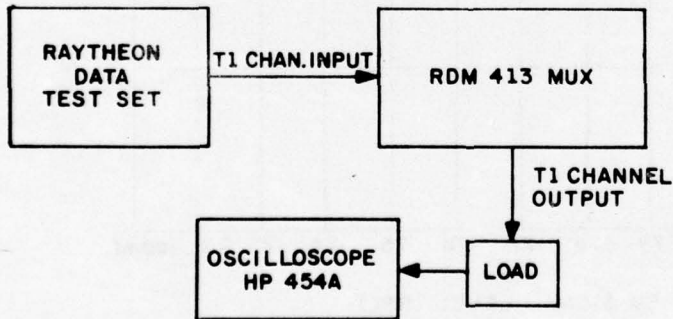

Figure 17. Pulse Jitter Test Configuration C (output)

3.9.3 Results and Analysis.

3.9.3.1 The jitter measured on the oscilloscope shows the time variations of the pulse with respect to the pulse input to the multiplexer. The jitter was constant for all RSL's from saturation to that level, producing 2.6×10^{-3} BER, and measured to be 300 nanoseconds.

3.9.3.2 At the 20.85 Mb/s data rate (TDM output port) and the whole RSL range, there was no observable jitter.

3.9.3.3 The jitter measured in this configuration is that pulse variation which the interfacing equipment will actually "see." For all combinations of transmitters, receivers, and the whole range of RSL's, the jitter was measured to be 75 nanoseconds. Pulse jitter increased from the first pulse to the fifty-sixth bit with no further increase. This variation exceeds the manufacturer's specification by 7 percent.

3.10 Mean Time to Acquire Frame.

3.10.1 The purpose of this subtest was to record the minimum and maximum time required for the multiplexer to acquire frame (synchronize) and then to compute the mean time from this data to compare with the manufacturer's objective.

3.10.2 Method. Figure 18 shows the test configuration to gather this data. The switch is an SN7400 flip-flop wired to pin 1 of U19 of the receiver common card in the multiplexer. The output triggered the oscilloscope and the time delay information was read directly from the oscilloscope.

3.10.3 The manufacturer required a maximum 5 milliseconds for the multiplexer to acquire frame at normal operating RSL's. The main multiplexer exhibited framing times of 200 microseconds to a maximum of 620 microseconds for 25 trials. Similarly, the standby multiplexer times ranged from 180 microseconds to 650 microseconds. The equipment performed well within the limits specified by the manufacturer. The calculated mean times to acquire frame were 411 microseconds for the main and 378 microseconds for the standby multiplexer.

3.11 Switching Error.

3.11.1 The purpose of this section was to measure errors generated when transmitters, receivers, and multiplexers were switched. In the testing of receivers with a "hit-less" (error-less) switch, verification of error free switching was the objective. In the testing of multiplexers and transmitters, the manufacturer's requirements were compared to collected data.

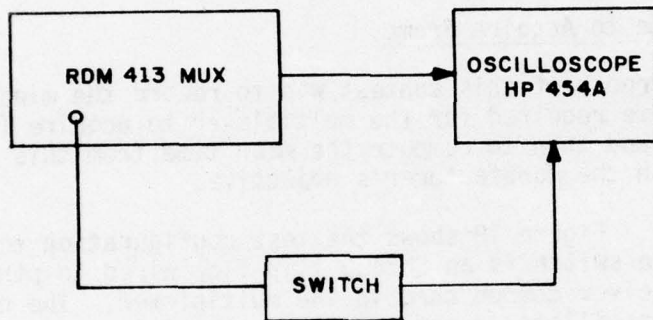

Figure 18. Mean Time to Acquire Frame Test Configuration

3.11.2 Method.

3.11.2.1 The RDS-80G was connected in standard back-to-back configuration and the transmitters were manually switched. Five transfers were performed from main to standby transmitters and five transfers were made from standby to main transmitters.

3.11.2.2 In a similar equipment connection, the transmitters were faulted five times. Faults were simulated by interrupting the 70 MHz IF drive, inducing switching errors, which were recorded.

3.11.2.3 In a similar equipment connection, the T1 line was inserted into channel one of the main multiplexer. The main transmitters were manually switched 10 times to standby and an equal number of transfers were performed in the reverse sequence.

3.11.2.4 In the first of the three subtests on receiver switching, manual and remote switching were studied. The procedure was to vary the receiver input level and at the moment of switching record the errors. The unit was set in the maintenance mode.

3.11.2.5 For the second receiver subtest, the received levels were set close enough to establish automatic switching at a rate slightly greater than one per second. The frequency counter measured the errors generated.

3.11.2.6 A delay line was introduced between receiver one and receiver two by installing sections of RG-59 cable. The delay was increased by 19 nanoseconds and the units set to manual/remote mode. Again, errors were recorded at switch time.

3.11.2.7 Automatic and manual switching of the multiplexer was tested. Errors were measured by feeding a T1 signal to the RDM413 from the data test set and detecting the errored data on the T1 stream recovered from the RDM413. Manual switching was performed by depressing the appropriate switch, and automatic switching was enacted by failing the supergroup at the front panel test jacks. Errors were counted for both modes.

3.11.3 Results and Analysis.

3.11.3.1 When transmitters were switched manually from main to standby, transmitter B exhibited an average of 25 errors for five transfers. Similarly, at the 20.85 Mb/s rate, transmitter B standby averaged two errors when switched to the main mode. The manufacturer's specification for this type of switching was not stated.

3.11.3.2 When the IF was faulted five times, no errors were recorded when the transmitters switched automatically. The manufacturer's specification is given as a switch time of 20 nanoseconds. At 20.85 Mb/s, each bit space is 48 nanoseconds and no errors should be seen. The manufacturer's goal was attained in this test.

3.11.3.3 In the third subtest where the main multiplexer drove the transmitter B, an average of 158 errors was recorded when the main transmitter was switched to standby. Similarly, an average of 81 errors was observed when the standby transmitter was switched to main. The errors observed in this section should correlate closely with those reported in section 3.11.3.1, but there were significantly more errors in this subtest. The reason for this discrepancy is being studied.

3.11.3.4 For the case of manual/remote switching at 20.85 Mb/s rate in receiver rack A, no errors were observed. Error-free switching was the stated manufacturer's specification.

3.11.3.5 For automatic switching, the manufacturer's design was to cause no errors. The data confirmed the error-free operation.

3.11.3.6 In the case of the manual/remote switching with a 19 nanosecond differential delay, again no errors were measured as specified by the manufacturer. Nineteen nanoseconds at the supergroup rate corresponds to approximately 0.4 bit space.

3.11.3.7 Manual switching performance of the multiplexer is not specified by the manufacturer. The stated objectives of the automatic mode was a switching time of less than 150 milliseconds or 147,000 bit spaces. The average number of errors measured in the manual mode at the transmitter when switched from main to standby multiplexer was 4,690 and 5,596 when switched from standby to main at the receiver. The main to standby transfer yielded 5,476 errors and 8,365 errors for the standby to main switch. Averages for the automatic switching at the transmitter multiplexer were 6,637 errors for main to standby and 9,017 errors for standby to main switching. At the receiver, 11,700 errors were measured when the multiplexer was switched from main to standby and 8,765 errors for the standby to main transfer. The worst case switching generated 14,000 errors which is one order of magnitude better than the stated objective.

3.12 Interface Between Multiplexers.

3.12.1 The objective of this test was to determine whether the RDM-413 time division multiplexer (TDM) would interface and operate with the CY-104 and TD-968A D2 multiplexers.

3.12.2 Procedure. The T1 input and output lines of the RDM413 were connected in normal loop fashion to the respective terminals of the CY-104 and TD-968.

3.12.2 Results and Analysis.

3.12.2.1 The D-2 multiplexer would not acquire a stable frame lock when the interconnection was completed. Further investigation revealed that frame would be acquired for a short period and then would be lost for approximately 10 milliseconds. This chronic loss of frame lock rendered the equipment unsuitable for reliable operation.

3.12.3.2 The unstable synchronization was found to be the result of the T1 regeneration technique in the RDM413. In lieu of pulse rate averaging circuitry, two oscillators were used on a time-sharing basis such that the long term average data rate was identical to the rate transmitted from the distant terminal. In the original configuration, the two clocks generated 24.707712 MHz and 24.797824 MHz. These signals were then divided by 16 to clock the T1 outputs between 1.544232 and 1.543614 MHz. These rates correspond to T1 +150 and -250 parts per million (ppm). Specified tolerances of T1 +100 and -200 ppm would thereby ensure operation within the limits of the equipment.

3.12.3.3 The first attempt to interface the equipment was to readjust the clock circuitry of the TD-968 to a higher rate in an effort to force the RDM413 to clock output data consistently from the higher frequency clock. A slight improvement was realized, but lock was not retained for long enough periods to permit testing.

3.12.3.4 The internal clocks in the RDM413 were replaced with external frequency synthesizers and the frequency difference reduced to the point where enough stability in frame lock was obtained to perform tests. The following chart illustrates the results:

	Clock frequencies	T1 rate frequencies	T1 tolerance
CY-104	24.704956 MHz	1.54405975 MHz	±39.6 ppm
	24.703000 MHz	1.5439375 MHz	
TD-968	24.707000 MHz	1.5441875 MHz	±67.8 ppm
	24.704348 MHz	1.54402175 MHz	

NOTE: The TD-968 was adjusted to operate higher than the nominal T1 rate of 1.544 Mb/s. The T1 tolerance column is based on an equal frequency variation about the center frequency.

3.12.3.5 The normal RDM413 clock spacing appears to perform satisfactorily with D-1 and D-3 type primary multiplexers which have a line rate tolerance of ±100 ppm but as shown above, had to be considerably reduced to interface with a D-2 type multiplexer having a line rate tolerance of ±50 ppm. Further differences in the method of timing

recovery between the D-1/D-3 and D-2 approaches still do not permit totally satisfactory interfaces due to the difficulty of D-2 type multiplexers in maintaining lock in the presence of nearly instantaneous data rate transitions.

3.12.3.6 Although the technique of clock averaging poses a problem aspect as related here, the technique does possess potential merit on a system basis. The manufacturer's claim is that the technique of switching between two clocks introduces a certain amount of "jitter" into the system which will not increase over tandem RF links. This may be worthy of further investigation over a multilink system to evaluate the technique. Jitter of this type is known as "slewing jitter" and was not included in the tests reported in section 3.9.

3.13 Cross-Polarization Test.

3.13.1 The objective of this test was to gather RSL data to evaluate cross-polarization characteristics on a limited basis. The technique of cross-polarization doubles the communication traffic without increasing frequency spectrum occupation. However, antenna design and orientation, multipath interference, co-channel transmissions, and atmospheric variations reduces cross-polarization isolation and efficiency. This section presents isolation data on an operating link (see figures 29, 30, and 31) and an analysis predicting general performance characteristics of cross-polarization.

3.13.2 Procedure.

3.13.2.1 The link transmitted data from Site Sibyl on its vertically polarized antenna to the CTA compound. The transmitter at Sibyl for the horizontally polarized antenna was disabled. At the CTA, the received signal level was recorded on a strip chart for both the vertical and horizontal feed horns. The vertically polarized received signal was then compared to the horizontally polarized received signal. This difference was the measure of cross-polarization isolation.

3.13.2.2 Received signal level data was also recorded from a vertically polarized 11 GHz radio on the same test link. This data was used to compare fading of an 11 GHz radio with an 8 GHz radio.

3.13.3 Results and Analysis.

3.13.3.1 This test was conducted over a continuous period of 65 hours and 6 minutes from 1415 on Friday, 6 December 1974 to 0721 Monday, 9 December 1974. During this period there was no precipitation. The temperature ranged from lows of 30 to 34 degrees Fahrenheit to highs of 52 to 62 degrees Fahrenheit over the test period. The maximum wind velocity ranged from 8 to 14 knots occurring approximately at mid-day. Sunset was at 1717 and sunrise at 0708.

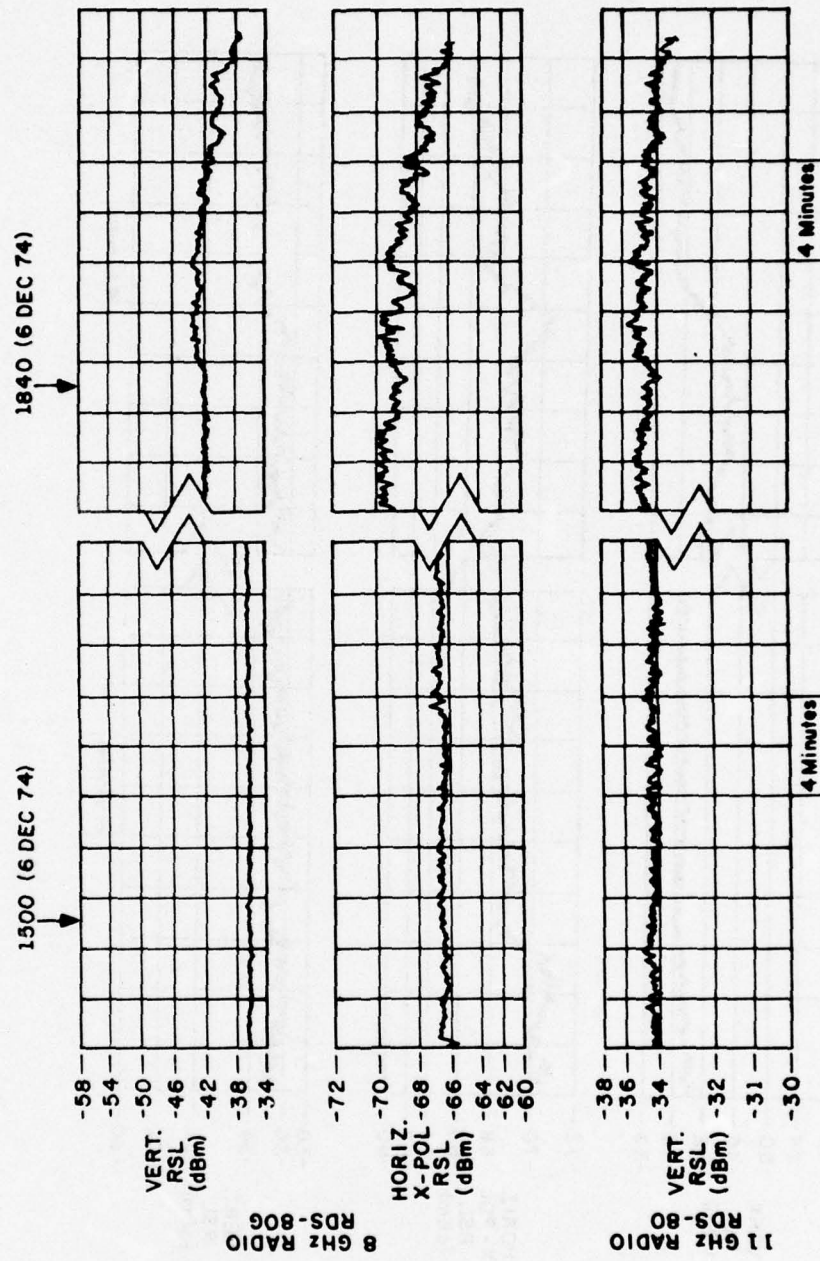

Figure 19. Cross-Polarization Data Excerpt (1500-6 Dec 74)

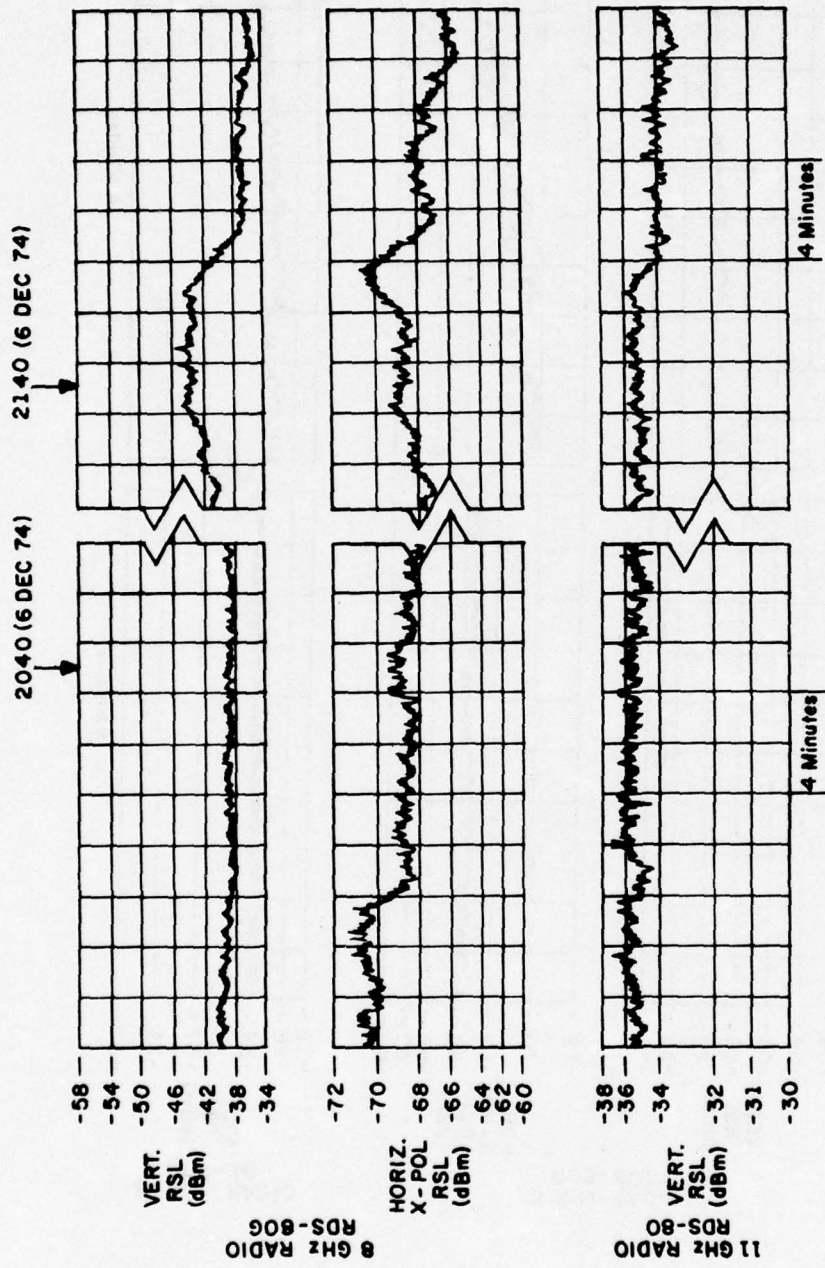

Figure 20. Cross-Polarization Data Excerpt (2040-6 Dec 74)

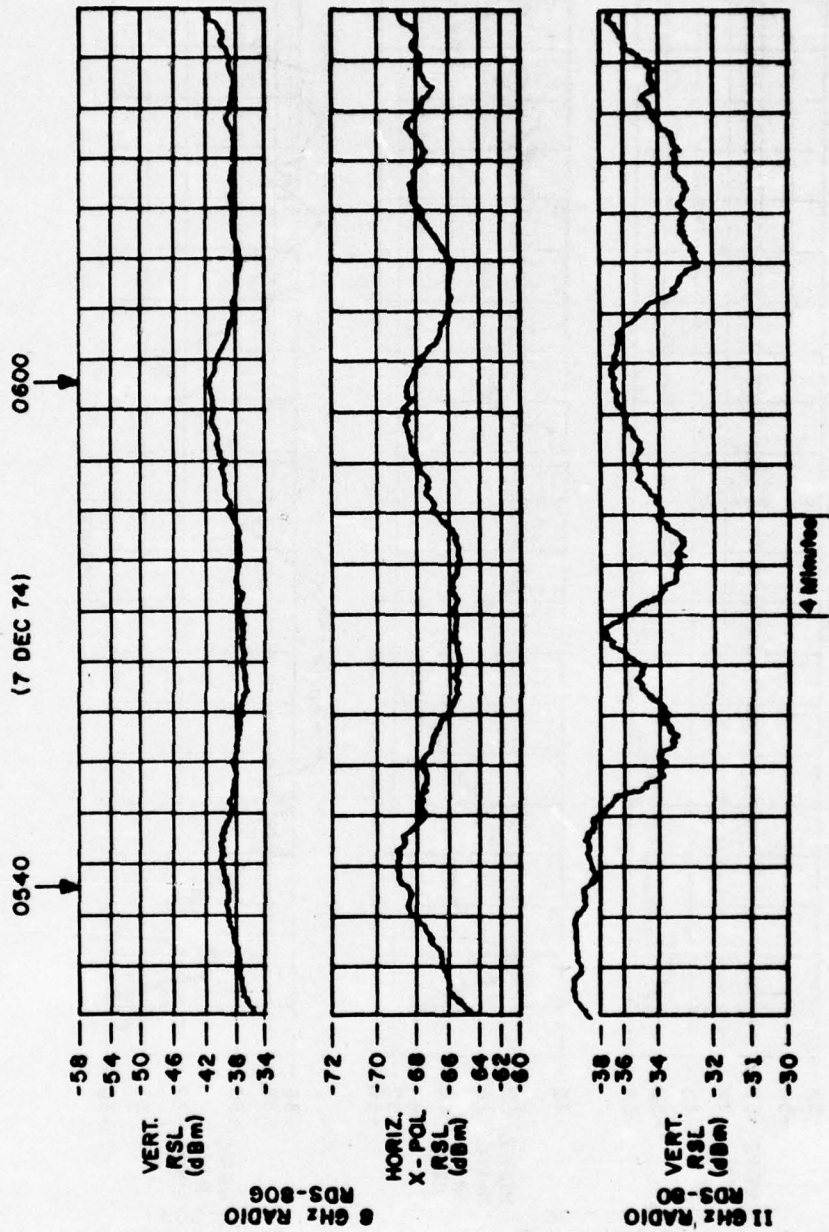

Figure 21. Cross-Polarization Data Excerpt (0540-7 Dec 74)

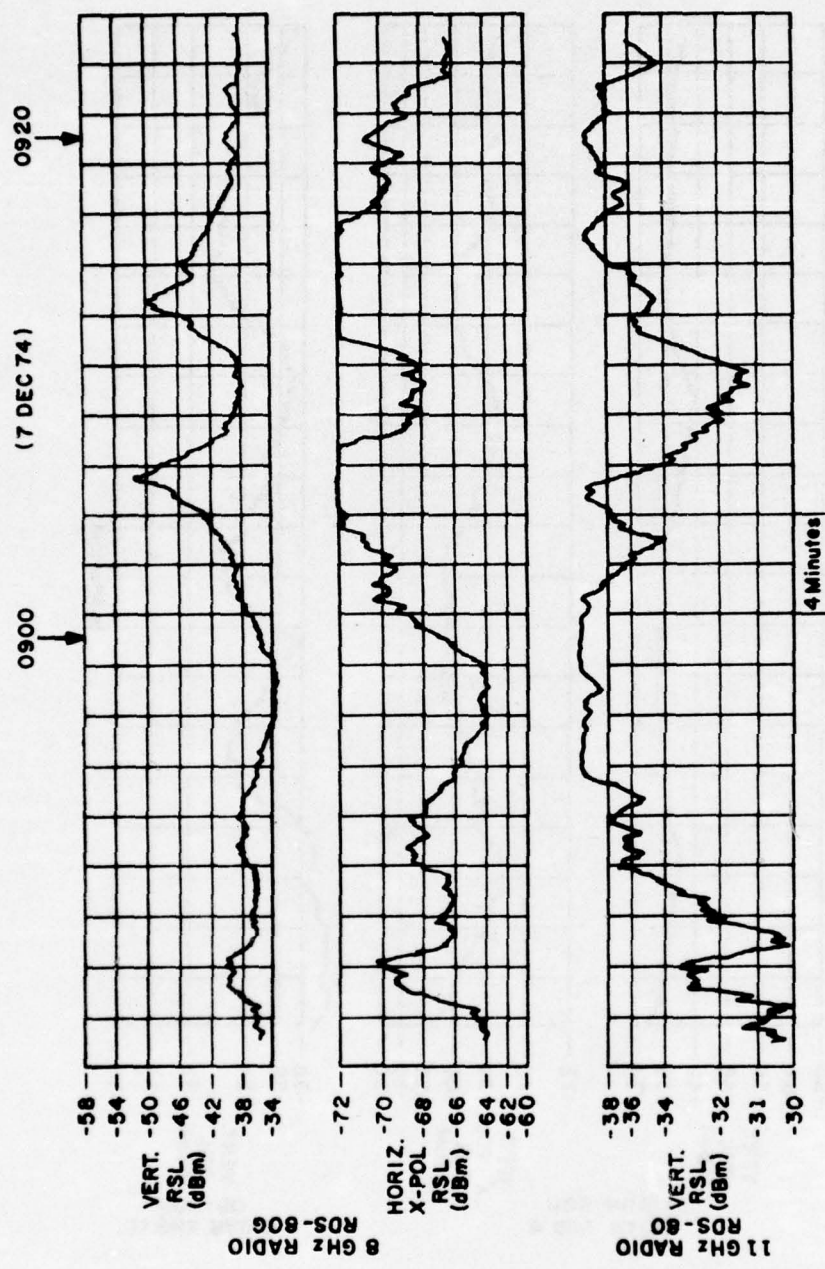

Figure 22. Cross-Polarization Data Excerpt (0900-7 Dec 74)

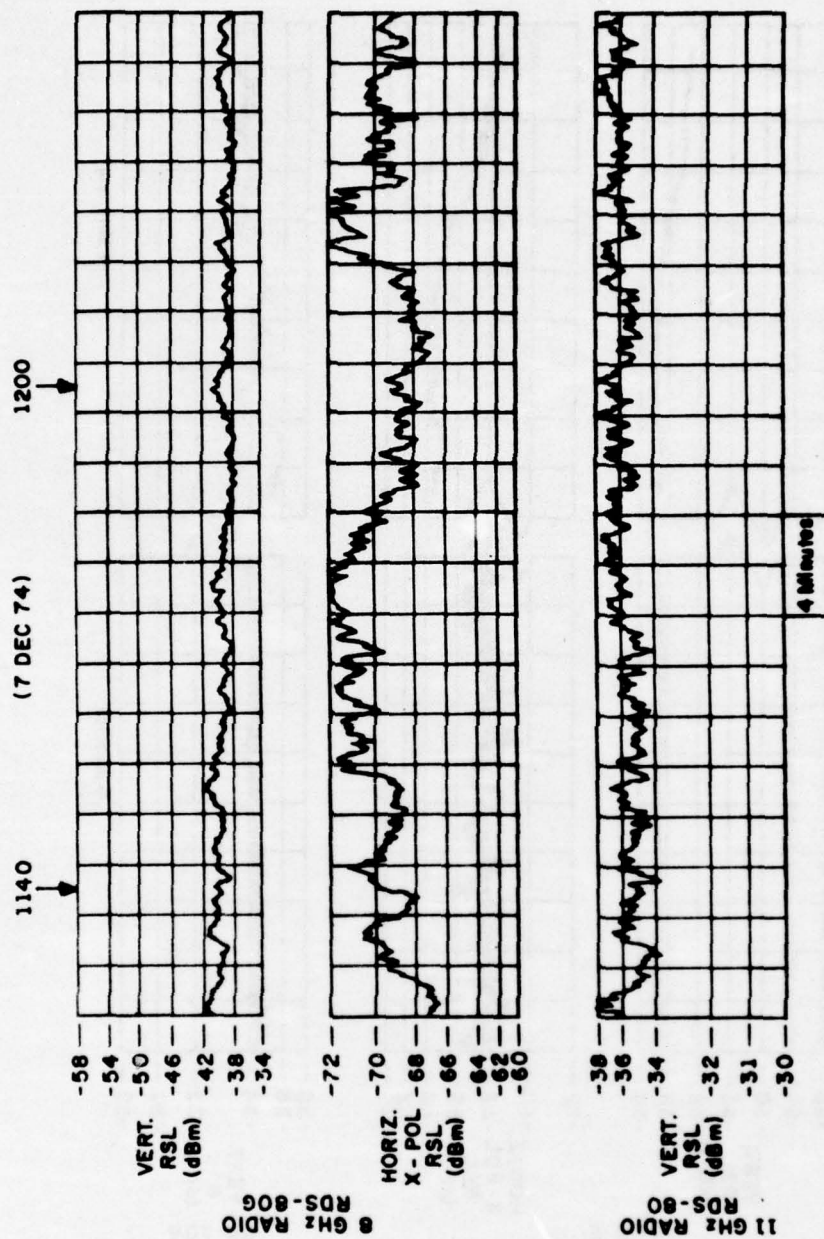

Figure 23. Cross-Polarization Data Excerpt (1140-7 Dec 74)

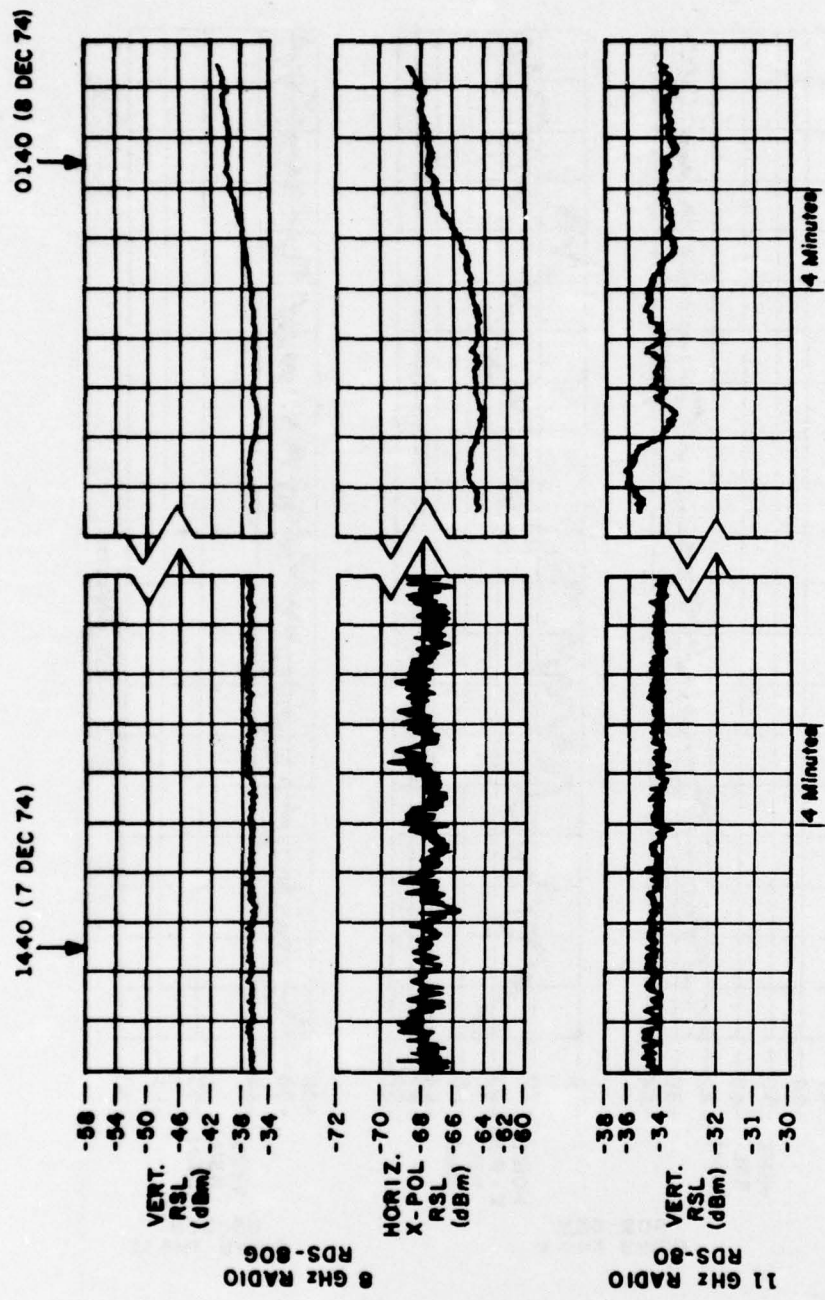

Figure 24. Cross-Polarization Data Excerpt (1440-7 Dec 74)

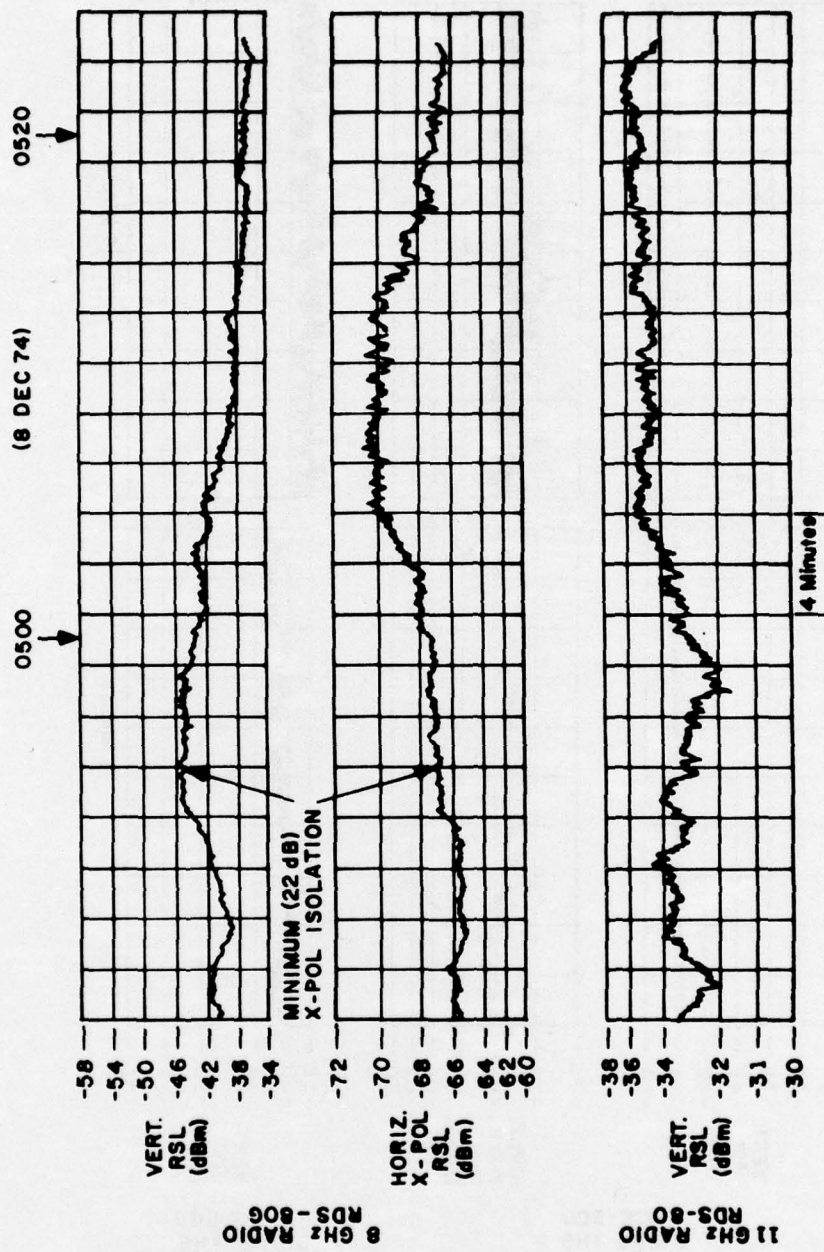

Figure 25. Cross-Polarization Data Excerpt (0500-8 Dec 74)

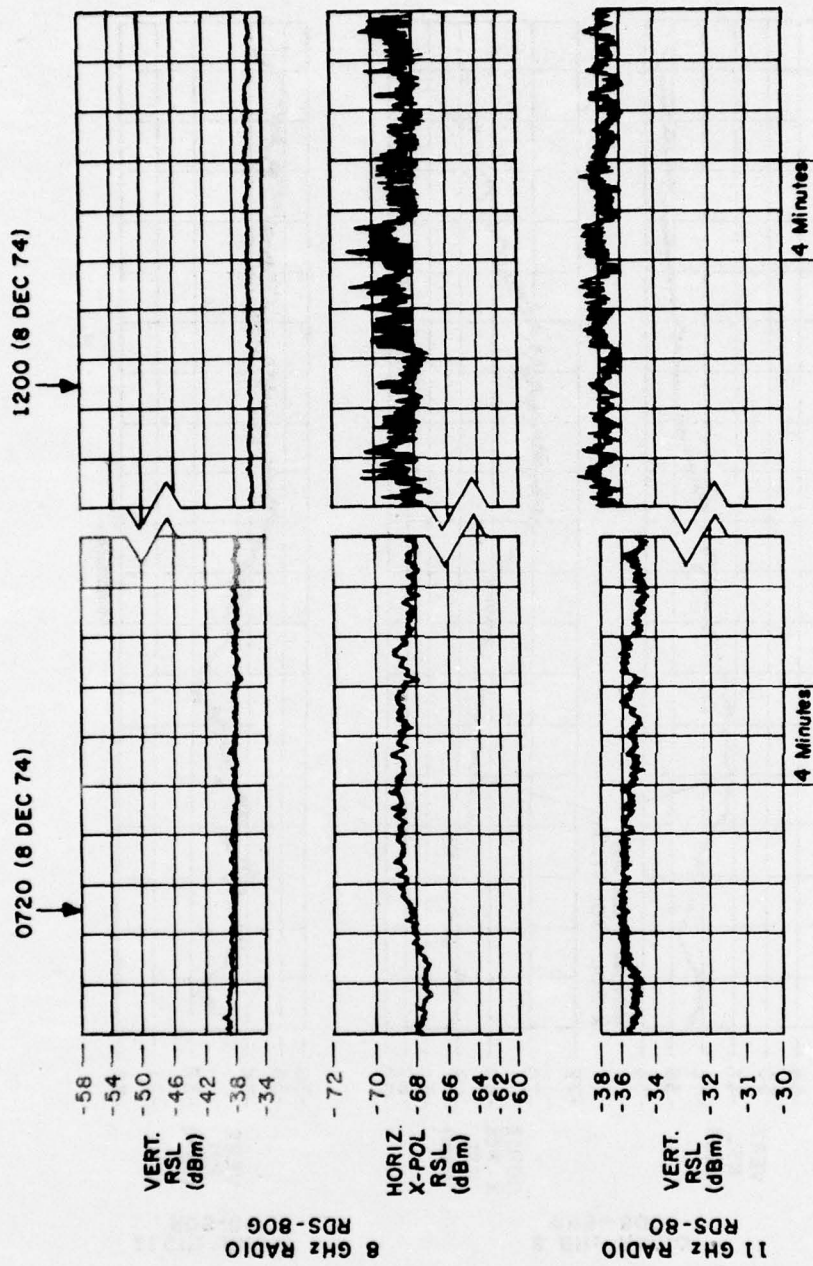

Figure 26. Cross-Polarization Data Excerpt (0720-8 Dec 74)

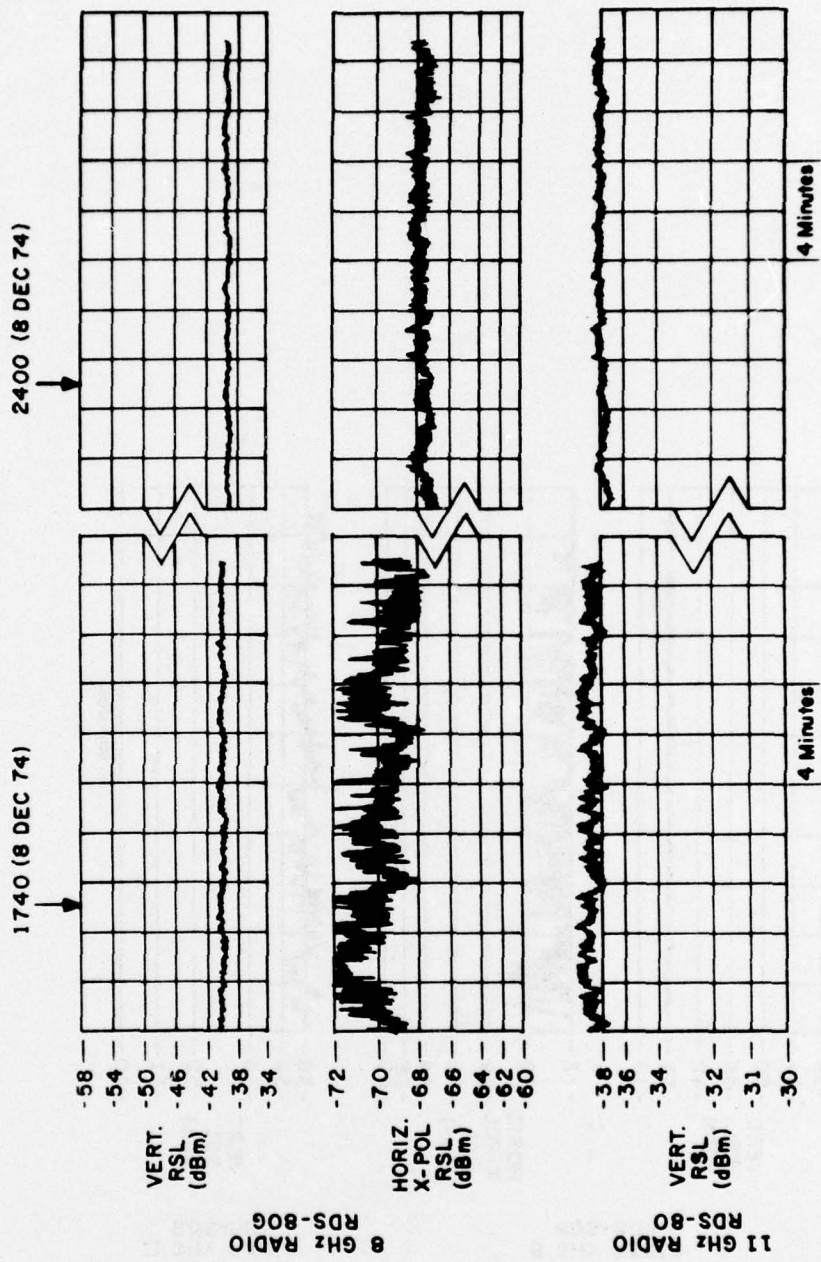

Figure 27. Cross-Polarization Data Excerpt (1740-8 Dec 74)

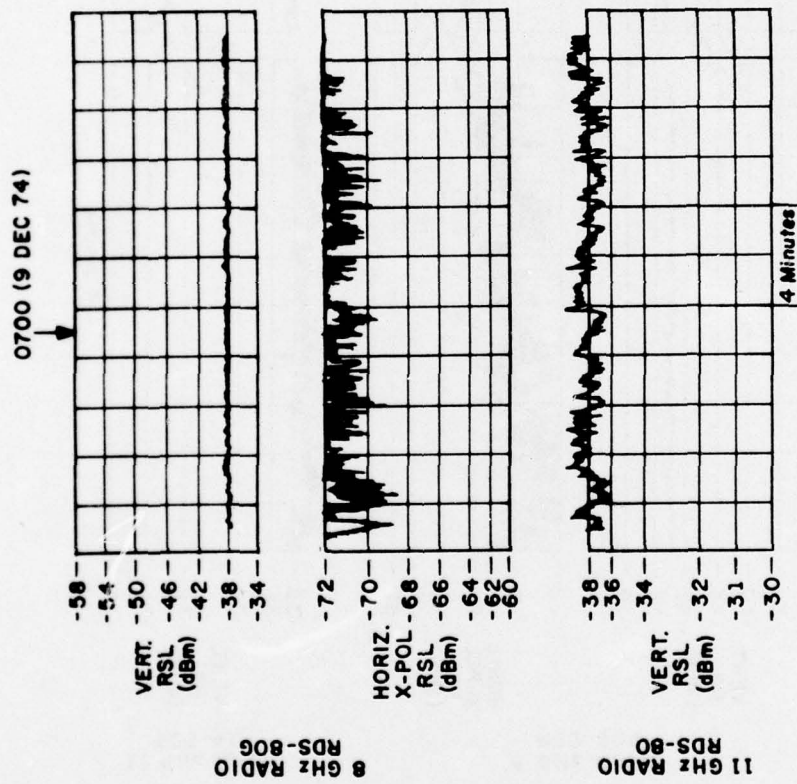

Figure 28. Cross-Polarization Data Excerpt (0700-8 Dec 74)

3.13.3.2 The results are presented in figures 19 through 28 showing portions of the strip chart recordings typical of the long time interval.

3.13.3.3 There were 48 errors recorded for the RDS-80G (8 GHz radio) and 9 for the RDS-80 (11 GHz radio). The errors occurred in two bursts, one at 1502 on 8 December 1974 and the other at 0357 on 9 December 1974. The errors were measured at the T1 bit rate (1.544 Mb/s). The received signal level for both vertical and horizontal X-pol received signal level indicated no extreme changes which might have caused the errors.

3.13.3.4 The received signal level for the RDS-80G ranged from -34 dBm to -58 dBm. The received signal level was -38 dBm or higher for about 80 percent of time. The lowest level, -58 dBm, occurred as sharp peaks lasting only for short periods, in the order of minutes. In general, the received signal level did not go below -46 dBm for periods longer than 5 minutes. The X-pol isolation ranged from a low of 22 dB to greater than 35 dB. The X-pol isolation was 30 dB or greater for more than 90 percent of the test period. The low of 22 dB existed only for less than 10 minutes (see figure 25). The low range of 22 dB to 25 dB lasted less than one hour. The lows occurred during the early morning of 8 December, 0200 to 0500. During this period, no errors were recorded.

3.13.3.5 Analysis of the strip chart recordings of received signal level of the RDS-80G compared to the X-pol received signal level indicates a correlation of variations in levels 90 percent of the time. That is, a decrease or increase in one is reflected in the other. There are periods of time (see figure 25 at 0506) where there is no correlation. An increase in one shows a decrease in the other. The magnitude of increases or decreases in the received signal levels and X-pol are not equal.

3.13.3.6 There appears to be no correlation between time of day and the recording variations. The recordings display the random nature of the signals during the same time period on each day, including sunsets and sunrises.

3.13.3.7 There appears to be some correlation between signal variations at 8 GHz and 11 GHz as most data indicates, however, as shown figures 21, 22, 24, and 25, when there was an increase or decrease in the 8 GHz level there was an opposite variation in the 11 GHz received signal level. Figure 19 shows that at 8 GHz there is approximately a 4 dB decrease in signal level while at 11 GHz the signal level changed only 1 dB. Figure 21 shows the opposite at 8 GHz the received signal is $-39 \text{ dBm} \pm 2 \text{ dB}$ while at 11 GHz it was $-36 \text{ dBm} \pm 3 \text{ dB}$. At 0550 on 7 December 1974, the 8 GHz level was fairly constant but the 11 GHz radio showed a peak.

3.13.3.8 The analysis indicates that the required X-pol isolation is attainable on this test link under ideal weather conditions. It shows that there is a random nature in the receive signals which are not correlated to time of day or frequencies tested.

APPENDIX A

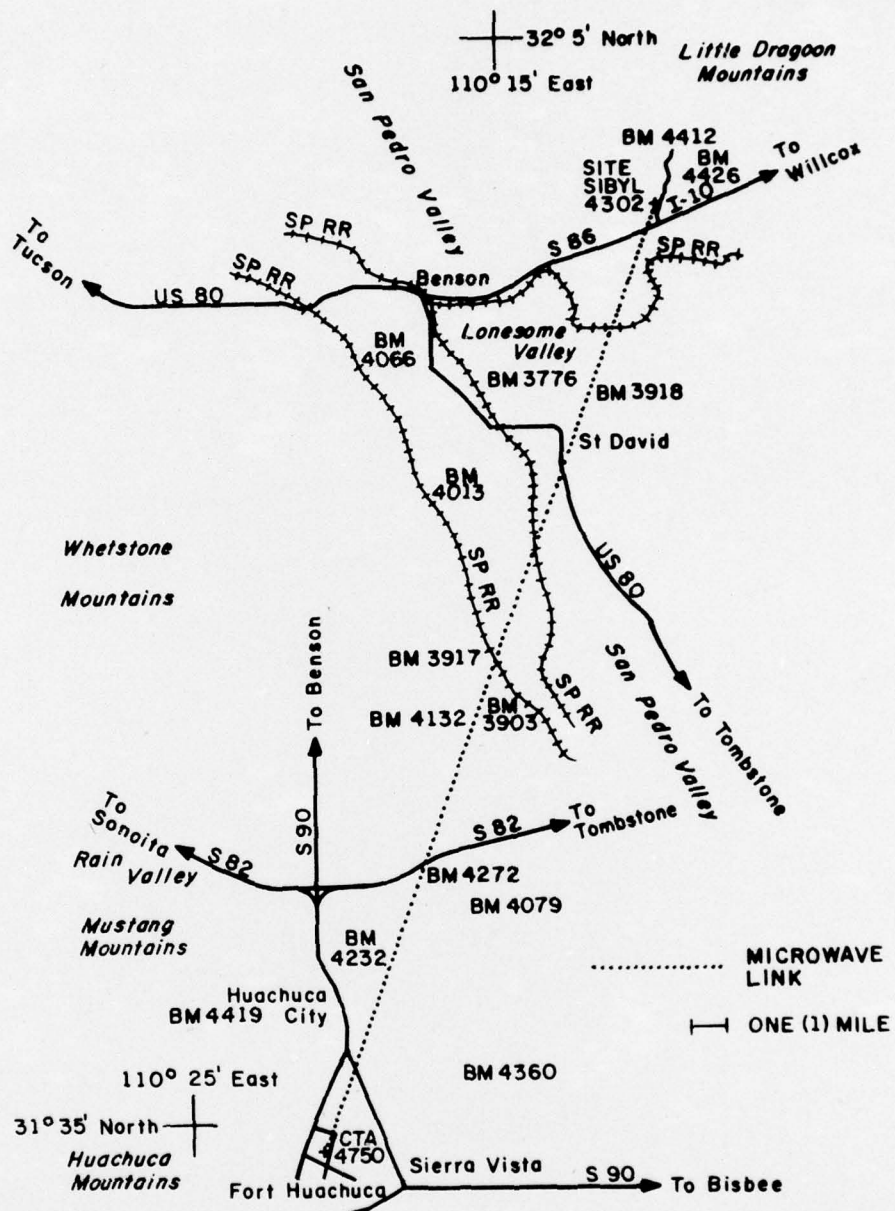

Figure 29. Simplified Map: CTA to Sibyl Microwave Link

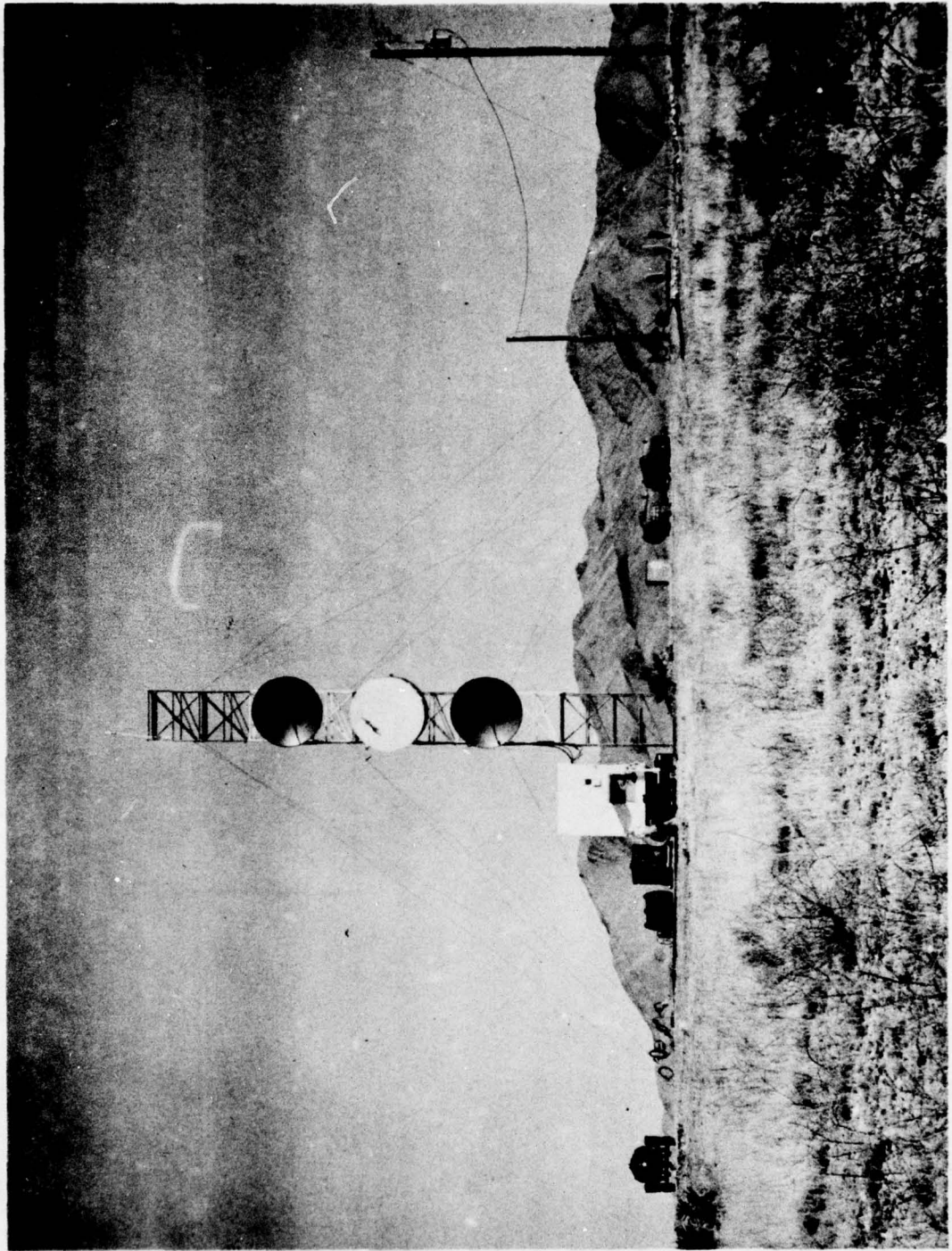

Figure 31. Photograph of Site Sibyl (24 Jan 75)

APPENDIX B

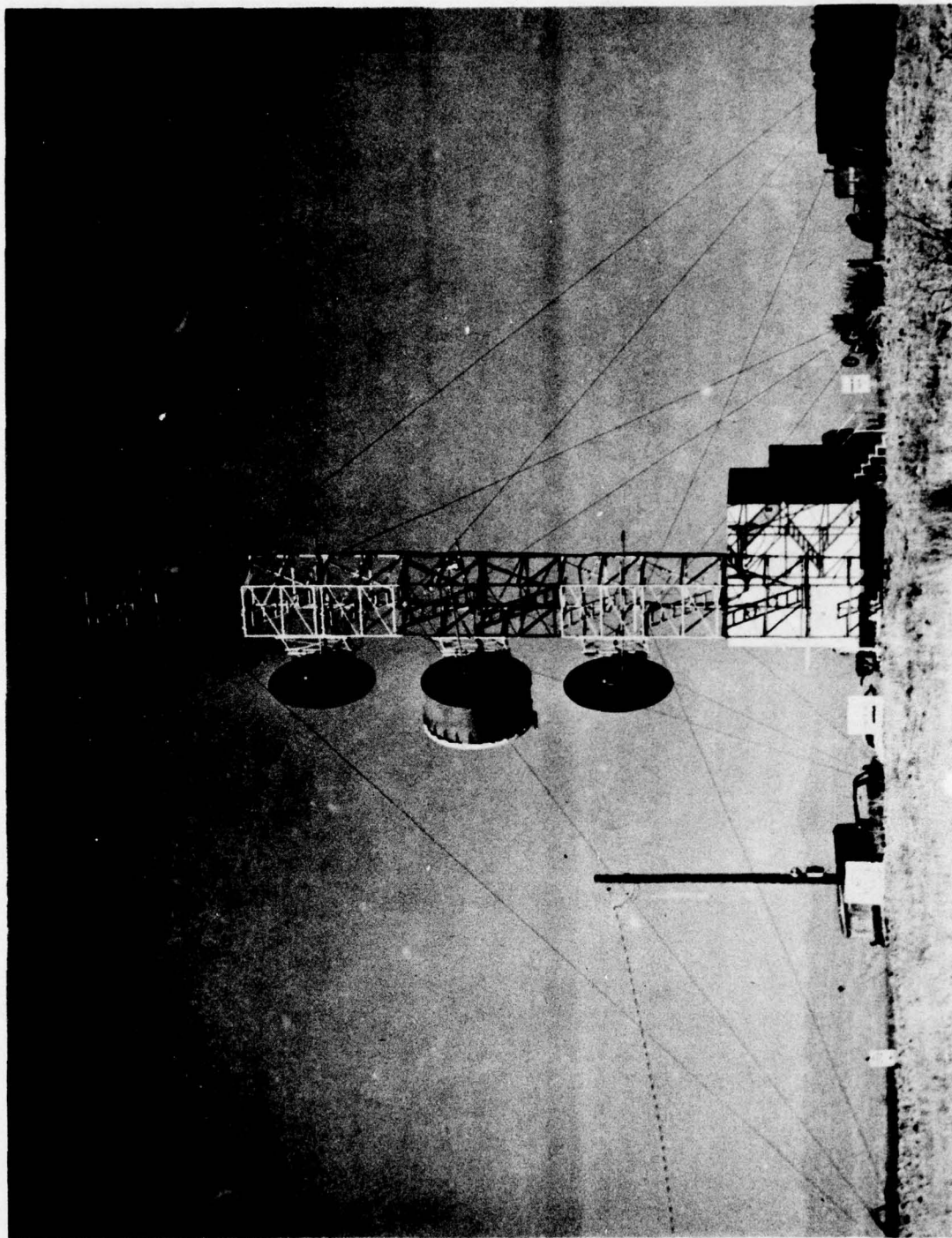

Figure 30. Photograph of Site Sibyl (24 Jan 75)

APPENDIX C

FCC Docket Number 19311 was formally released on 27 September 1974 to be effective 1 November 1974. Pertinent points of this docket with respect to this report are the determination of necessary bandwidth and the emission limitations restriction. The determination of the necessary bandwidth of digital modulation using PSK (F9Y) is given by the formula $B_n = \frac{2RK}{\log_2(S)}$

Where: B_n = necessary bandwidth in MHz
 R = bit rate in bits-per-second
 K = 1
 S = number of signaling states

Substituting the values for 12.6 Mb/s data into a QPSK transmitter yields:

$$B_n = \frac{2 (12.6 \times 10^6) (1)}{\log_2(4)}$$

$$B_n = \frac{25.2 \times 10^6}{2} = 12.6 \text{ MHz}$$

This means that for a system employing QPSK modulation, the necessary bandwidth in hertz is numerically equal to the bit rate in bits-per-second.

For systems operating below 15 GHz, the radiated emissions must be contained within a "mask" comprised of several segments. Measurements to apply these segments are required to be made in 4 kHz band increments. The attenuation required below the mean power output is given by the formula:

$$A = 35 + 0.8 (P-50) + 10 \log_{10}(B)$$

Where: A = attenuation (in decibels) below the mean output power level
 P = percent removed from the carrier frequency
 B = authorized bandwidth in MHz

This must be tempered by two additional limitations. First, the attenuation greater than 50 percent removed must be a minimum of 50 dB, and secondly, attenuation greater than 80 dB is not required.



DEPARTMENT OF THE ARMY
U. S. ARMY COMMUNICATIONS COMMAND
FORT HUACHUCA, ARIZONA 85613

FEB 27 1975

CC-OPS-SM

SUBJECT: Digital Transmission Evaluation Project (DTEP), RDS-80G Final Test Report

SEE DISTRIBUTION

1. Inclosed for your information is the RDS-80G Final Test Report CCC-CED-DTEP-004, prepared for this command by the U. S. Army Communications-Electronics Engineering Installation Agency (USACEEIA).
2. This report presents results of both back-to-back and link tests of the RDS-80G. Link tests were performed on a link of approximately 32 miles (51 kilometers).
3. These tests were part of investigations of digital wideband aspects conducted at Ft Huachuca, AZ. Under the DTEP, commercially developed items, concepts, and techniques which have potential for digital DCS and non-DCS communications requirements are evaluated. The information obtained is applied to development of realistic digital criteria, standard digital test methods, and guidelines for effective modernization of communications systems.
4. Additional DTEP reports will be provided as they become available.

FOR THE COMMANDER:

1 Incl
as

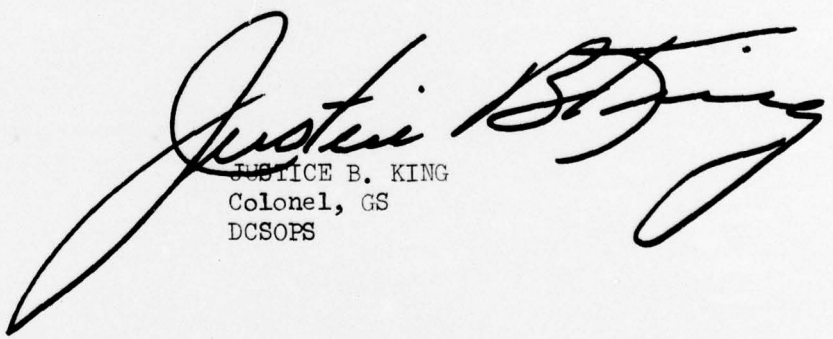
JUSTICE B. KING
Colonel, GS
DCSOPS

CC-OPS-SM

SUBJECT: Digital Transmission Evaluation Project (DTEP), RDS-80G Final Test Report

DISTRIBUTION:

DIR DCA, ATTN: Code 470, Washington, DC 20305 (1 cy)
DIR NSA, ATTN: Code R 15, Ft Meade, MD 20755 (2 cys)
CDR DCEC, ATTN: R220, 1860 Wiehle Ave., Reston, VA (2 cys)
HQ DA, ATTN: DAMO-TCS-T, Washington, DC 20305 (4 cys)
CDR USACSA, ATTN: CCM-CS, Ft Monmouth, NJ 07703 (2 cys)
CDR Rome Air Development Center, ATTN: DCLD, Griffis AFB, NY 13440 (1 cy)
CSAF, Washington, DC 20330 (3 cys)
CDR Naval Telecommunications Command, ATTN: 3426, 4401 Massachusetts Ave NW,
Washington, DC 20390 (2 cys)
CDR USAECOM, ATTN: AMSEL, Ft Monmouth, NJ 07703 (1 cy)
CDR USATECOM, ATTN: AMSTE, Aberdeen Proving Ground, MD 21005 (1 cy)
National Bureau of Standards, Electromagnetics Division, ATTN: W. J. Alspach, Boulder,
CO 80302 (1 cy)
NCA/EPE, Griffis AFB, NY 13440 (2 cys)
OT/ITS, Boulder, CO 80302 (1 cy)
CDR AFCS, ATTN: EPES, Richards-Gebaur AFB, MO 64030 (1 cy)
CDR USAEPG, ATTN: STEEP, Ft Huachuca, AZ 85613 (1 cy)
DIR DCA, ATTN: NSA Liaison Office, Washington, DC 20305 (1 cy)
Defense Documentation Center, Cameron Station, Alexandria, VA 22314 (1 cy)

DISTRIBUTION

	<u>COPIES</u>
DCA/470, Washington, D. C. 20305	1
DCEC/R220, 1860 Wiehle Avenue, Reston, VA 22070.	2
DA/DAMO-TCS-T, Washington, D. C. 20305	4
USACC/CC-FD-MMR, Fort Huachuca, AZ 85613	4
USACC/CC-POA-ST, Fort Huachuca, AZ 85613	2
USACSA/CCM-EU-ED, Fort Monmouth, NJ 07703.	2
USAECOM/AMSEL-NL-P3, Fort Monmouth, NJ 07703	1
NCA/EPE, Griffis AFB, NY 13440	2
RADC/DCLD, Griffis AFB, NY 13440	2
HQ AFCS/EPES, Richards-Gebaur AFB, MO 64030.	2
Naval Telecommunications Command, ATTN: 3426, 4401 Massachusetts Avenus, NW, Washington, D. C. 20390.	2
US Department of Commerce, Office of Telecommunications, Institute for Telecommunications Sciences, ATTN: Richard Skerjanec, Boulder, CO 80302	2
USAEPG/STEEP-MT-GR, Fort Huachuca, AZ 85613.	4
USACEEIA	
CCC-CED.	10
CCC-TED.	5
CCC-TCD.	2
NSA, Code 4023, Fort Meade, MD	2
DCA, ATTN: NSA Liaison Office, Washington, D. C. 20305.	1
National Bureau of Standards, Electromagnetics Division, ATTN: W. J. Alspach, Boulder, CO 80302.	1
Defense Documentation Center	15