

AD-A032 859

MATERIALS RESEARCH LABS MARIBYRNONG (AUSTRALIA)  
WEATHERING OF FILAMENT-WOUND GLASS-EPOXY TUBES, (U)  
MAY 76 J G WILLIAMS  
MRL-R-662

F/G 11/4

UNCLASSIFIED

NL

| OF |  
AD  
A032 859



END  
DATE  
FILMED  
1-77



12  
B.S.

ADA 032859

**DEPARTMENT OF DEFENCE**  
**AUSTRALIAN DEFENCE SCIENTIFIC SERVICE**  
**MATERIALS RESEARCH LABORATORIES**  
**MARIBYRNONG VICTORIA**

**REPORT**

**MRL-R-662**

**WEATHERING OF FILAMENT-WOUND GLASS-EPOXY TUBES**

John G. Williams

APPROVED  
FOR PUBLIC RELEASE

D D C  
RECORDED  
NOV 30 1976  
D



MELBOURNE

© Commonwealth of Australia  
MAY, 1976

**UNCLASSIFIED**

|                                 |              |                          |
|---------------------------------|--------------|--------------------------|
| DDO                             | Defn Section | <input type="checkbox"/> |
| UNANNOUNCED                     |              | <input type="checkbox"/> |
| JUSTIFICATION                   |              |                          |
| BY                              |              |                          |
| DISTRIBUTION/AVAILABILITY CODES |              |                          |
| Dist.                           | AVAIL.       | and/or SPECIAL           |
| A                               |              |                          |

**DEPARTMENT OF DEFENCE**  
**AUSTRALIAN DEFENCE SCIENTIFIC SERVICE**  
**MATERIALS RESEARCH LABORATORIES**  
**MARIBYRNONG VICTORIA**

**REPORT**

74

MRL-R-662

6

WEATHERING OF FILAMENT-WOUND GLASS-EPOXY TUBES

10

John G. Williams

11

May 76

12

24p.

DDC  
**RECEIVED**  
 NOV 30 1976  
**RECEIVED**  
 D

---

POSTAL ADDRESS: Chief Superintendent, Materials Research Laboratories,  
 P.O. Box 50, Ascot Vale, Victoria 3032, Australia

---

409014

JB

---

1. Security Grading/Release  
Limitation :

(a) Document content :  
Unclassified

(b) This Page :  
Unclassified

2. Document Type/Number :

MRL-R-662

---

3. Document Date :

MAY, 1976

---

4. Title and Sub-Title :

WEATHERING OF FILAMENT-WOUND GLASS-EPOXY TUBES

---

5. Personal Author : John G. Williams

6. Corporate Author : Materials Research Laboratories,  
Maribyrnong, Victoria

---

7. Abstract (See Reverse)

---

8. Descriptors :  
Composite Materials  
Weathering  
Filament Wound Materials  
Launch Tubes

9. Cosati Classifications :

1104, 1407

---

11. Task Reference No.:

RD73 TASK 68/1

---

10. Library distribution :

MRL (Maribyrnong)  
MRL (S.A. Branch)  
MRL (N.S.W. Branch)  
WRE  
Campbell Park Library  
ADSATIS Annex

12. Sponsoring Agency  
Reference :

-

---

13. Cost Code :

34760

---

14. Imprint :

MARIBYRNONG - MRL - 1976

---

ABSTRACT

↓  
Filament-wound glass-epoxy tubes manufactured for use as a rocket-launcher component have been used to study weathering of unstressed composites in a hot-wet environment. Tubes were exposed in three forms: as wound; after grinding to a fixed diameter; and after coating with alkyd paint. Burst pressure and torsional rigidity tests were used to study the mechanical effects of degradation.

No significant deterioration could be detected mechanically after exposure in an unstressed state for two years at JTRU Innisfail, North Queensland. Minor loss of superficial glass fibre was observed on ground, uncoated specimens, but this relatively small deterioration was prevented by the use of the standard coating system. ↙

## C O N T E N T S

|  | <u>Page No.</u> |
|--|-----------------|
| 1. INTRODUCTION                                    | 1               |
| 2. EXPERIMENTAL                                    | 3               |
| 2.1 Materials                                      | 3               |
| 2.2 Manufacturing Process                          | 3               |
| 2.3 Mechanical Testing                             | 4               |
| 2.3.1 Torsional Rigidity                           | 4               |
| 2.3.2 Burst Pressure                               | 4               |
| 2.4 Exposure                                       | 5               |
| 3. RESULTS   | 5               |
| 3.1 Meteorological Data                            | 5               |
| 3.2 Visual Changes and Microbiological Examination | 5               |
| 3.3 Torsional Rigidity                             | 6               |
| 3.4 Burst Pressure                                 | 7               |
| 4. DISCUSSION                                      | 7               |
| 5. CONCLUSIONS                                     | 8               |
| 6. ACKNOWLEDGEMENTS                                | 8               |
| 7. REFERENCES                                      | 9               |

## WEATHERING OF FILAMENT-WOUND GLASS-EPOXY TUBES

### 1. INTRODUCTION

Composite materials, especially glass-fibre reinforced plastics, have been extensively used in military items, for example in radomes, hulls for small naval vessels, in target aircraft and mini-remotely-piloted vehicles, as bodywork in light weight transport, as rocket motor cases and launcher tubes and in piping for oil and lubricants. Usage is increasing with the development of high modulus fibres. Within Defence Science and Technology suggested uses include mortar components (1) and laser range-finder tripods (2).

The properties of glass-fibre composites have been reviewed by McCrum (3) and the factors affecting deterioration during outdoor exposure have also been extensively reviewed (4,5,6). One of the major problems in interpretation of data on weathering of composites is the variability of results (6) arising from inadequate control of significant variables such as sample preparation and insufficient definition of environmental factors in exposure conditions.

Recent trials (7,8) on exposure of thick walled, filament-wound rocket motor cases, at a number of sites including JTRU, Innisfail, North Queensland, showed that apparent severe degradation could be seen after two years exposure under hot-wet conditions. In those trials the principle mechanical measurement was a hydrostatic burst pressure test incorporating an internal liner. The liner in this test tends to seal minor flaws caused by faults in the matrix and consequently the test is sensitive primarily to the integrity of the glass. Reductions of about 20-30% in burst pressure after five years were recorded.

Day and Readdy (9) have studied the effect of weathering under temperate conditions on small hoop-wound cylinders, when exposed "as-wound", machined, and machined and coated; they found that degradation of all samples was unexpectedly slow. They suggested that the difference between their results and those of Maciejczyk et al. (8) could be related either to the use of bidirectionally wound cylinders or to the hot-wet conditions used by Maciejczyk. Either variable could have an influence on the rate of degradation. The accelerating effect of tropical conditions has been frequently reported (4-6). Wright (10) has studied the exposure of composites based on thermoplastic matrices at the hot-wet site at JTRU,

Innisfail, and at a temperate site (in Britain), and has shown that for those materials the rate of deterioration at the hot-wet site was approximately double that at the temperate site. Several authors (11-14) have suggested that moisture permeates slowly through the resin to the interfacial region causing a loss of adhesion of fibre to matrix which results in loss of strength and stiffness. Augl (14) has determined permeation rates in composites and has related water absorption with strength properties determined at elevated temperatures. As the moisture permeability of resin systems is very low compared to other plastics (13,14) it has been suggested that mechanical damage could accelerate degradation as then access of moisture through cracks in the matrix and along the fibre/matrix interface could occur (6,9).

In bidirectionally wound composites, individual fibre tows in one orientation are interwoven with successive fibre tows laid down in the other orientation as the pattern builds up in each layer. This results in creation of local stresses due to waviness in the fibres, and the formation of many resin-rich areas, compared to unidirectionally or hoop wound composites.

The present trial was designed to exaggerate the apparent rate of degradation by the use of thin walled samples which have a high surface area with exposed glass, as might represent the situation of a partially damaged component stored in the field.

The item selected for exposure was a glass reinforced, epoxy tube produced by filament winding. The tubes were manufactured at Explosives Factory, Maribyrnong (15) as a prototype component of the M72 Al launcher for the light anti-tank weapon (LAW). At one stage of manufacture surplus resin was ground off the external surface thus exposing glass and glass-resin interface. Tubes in this condition were taken to represent damaged specimens. The tubes in the end-item were painted and some samples of coated tubes were exposed to ascertain if any degradation which did occur could be prevented by the use of a standard surface coating (9,16,17). The M72 Al launcher has been in service for some years, in both tropical and temperate climates, and no reports of deterioration due to exterior exposure have been received.

In the present study, tubes were exposed at the hot-wet, cleared site at JTRU, Innisfail in three conditions :

- (i) as-wound
- (ii) after grinding off the outer surface
- (iii) after grinding and painting

## 2. EXPERIMENTAL

### 2.1 Materials

The resin system was based on a standard, unmodified bisphenol A resin, obtained from Dow Chemical (Aust) Ltd. (Resin DER 330). The curing agent was nadic methyl anhydride obtained from Hitachi Corporation (Methyl Himic Anhydride) and the accelerator was 2,4,6 tris-(dimethylamino methyl) phenol obtained from Robert Bryce and Co. Ltd. (DMP-30). The mixing ratio was :

|                        |           |
|------------------------|-----------|
| Resin DER 330          | 100 pt wt |
| Methyl Himic Anhydride | 80 pt wt  |
| DMP-30                 | 2.5 pt wt |

The glass fibre used was 20-end roving, E-glass supplied by Australian Fibre Glass Pty.Ltd.. It was AFG type K879 and was treated with an epoxy-compatible silane based finish (finish 879).

### 2.2 Manufacturing Process

The winding machine used was a McLean-Anderson Model W2 unit. Tubes were produced in 3.3 m lengths on a steel mandrel, which had been lightly coated with silicone oil release agent. Four layers of wet-impregnated glass were wound on to the mandrel at a helix angle of  $69^{\circ}$ . During winding the glass was pulled from the centre of the cheeses giving a twist of approximately  $720^{\circ}$ /metre. The band width employed was approximately 100 mm and a full layer was wound on during a single traverse of the mandrel. The system, therefore, can be considered unidirectional with no interweaving within the layer. The cure schedule was :

|  |       |
|--|-------|
| Initial cure at $100^{\circ}\text{C}$                        | 2 h   |
| Heating time between $100^{\circ}$ and $200^{\circ}\text{C}$ | 0.5 h |
| Post cure at $200^{\circ}\text{C}$                           | 2 h   |

After cure and removal from the mandrel, tubes were cut to length using a carbide disc cutter. Some of the as-wound tubes were centre-less ground to the required outside diameter in the presence of an unidentified oil-water cutting compound. Some of these ground tubes were then abraded with 360 grit paper, dried, degreased with mineral turpentine, sprayed with an air-drying grey alkyd primer, lightly abraded with 360 grit paper and coated with a single application of lustreless olive drab alkyd. The total film thickness was determined by microscopic examination to be about 50  $\mu\text{m}$ . The surface coatings consisted of an undercoat designated "Undercoat for Oil and Petrol Resistant Enamel Grey (18)" (Ref. No. A160, ex National Paint Products), and a finishing coat designated "Lustreless Olive Drab (19)" (Ref. No. X1088, ex Wattyl Pty.Ltd.). Dimensions of the ground tubes were length, 610 mm, internal diameter, 68 mm and external diameter, 71 mm. The

as-wound tubes had an outside diameter of approximately 73 mm. Glass content of as-wound and ground tubes were determined by ignition to be 51 and  $61 \pm 1\%$ , by weight, respectively.

## 2.3 Mechanical Testing

The physical tests used to monitor the changes in the tubes due to exposure were torsional rigidity and burst pressure. The first test was selected as it was non-destructive, was expected to be sensitive to variation in the interfacial region, and to be particularly sensitive to the surface properties of the tube. Burst pressure was used to correlate with other trials (8) and with manufacturing data (15).

### 2.3.1 Torsional Rigidity

Prior to exposure, the torsional rigidity of all tubes was determined (20). Thereafter, as specimens were withdrawn from exposure, the measurements were repeated. The test was also carried out on a control tube which was kept in an air conditioned laboratory for the duration of the trial.

A schematic diagram of the apparatus used for determining torsional rigidity is shown in Figure 1. The tubes were gripped by expanding a neat-fitting rubber insert inside the ends until the outside surface of the tube gripped the inside surface of two cylindrical caps, through which the torque was transmitted. The torque was applied by rotating a chuck at one end of the tube and was measured at the other end which was supported in an air bearing. The torque was determined using a tensile load cell rigidly fixed to a lever attached to the tube. The angular deflection of the tubes was measured between two light-weight levers using two linear displacement transducers.

The transducer outputs were fed differentially into the X channel and the force cell output was fed into the Y channel of an X-Y recorder. Thus, as the chuck was slowly rotated manually, a graph of torque versus differential deflection was obtained.

As the clamping system used in the torsional rigidity test required a close tolerance in both inside and outside diameters, it was necessary to machine the ends of the as-wound tubes to the same outside diameter as the ground specimens. The ground end was radiused to the original diameter to prevent undue stress concentration at that point. During exposure all ends were protected with black PVC insulation tape to maintain the close tolerances.

### 2.3.2 Burst Pressure

When a hydrostatic pressure is applied within an unsupported tube a bending moment will develop perpendicular to the tube axis due to slight variations in wall thickness and rigidity. Premature failure will then occur due to the high tensile stress in the outer surface approximately half-way along the tube. A jig was designed to prevent this. It consisted (21) of two cylindrical end fittings machined to within a close tolerance of the internal diameter of the tube and rigidly connected by a cylindrical spacer

of smaller diameter. Different spacers could be used for testing tubes of different lengths. A rubber ring on each end piece acted as a pressure seal but the tube was not otherwise restrained.

The pressurising system utilised a manually adjusted air-operated pump giving pressure magnification of up to 100 times the inlet air pressure with water as the pressure medium. Pressure was indicated on a dial gauge with a maximum-indicating needle. No internal liner was used.

Preliminary tests were carried out to establish the reproducibility of the test and the effects of grinding and of tube length. If the pressure was raised rapidly to about 50 MPa, failure of as-wound tubes was observed to occur after 20 seconds while at 30 MPa, the time to failure was about 120 seconds. To reduce the time dependence of the burst pressure to within experimental scatter, the rate of application of pressure was controlled to ensure that failure occurred within 10-20 seconds of commencing the test.

#### 2.4 Exposure

Twenty tubes were exposed horizontally (axis E-W) at JTRU, Innisfail on a rack at 45° facing north (Figure 2). Exposure commenced during February 1973. Specimens were withdrawn after 1, 3, 6, 12 and 24 months. Specimens withdrawn after one month showed no visual deterioration or change in torsional rigidity and were resubmitted to exposure to be withdrawn after 24 months (ground tube) and 48 months (as-wound tube).

### 3. RESULTS

#### 3.1 Meteorological Data

Meteorological data for the trial period is shown in Table 1. Values are given for the maximum, minimum and mean daily values for the elapsed periods between withdrawals but are the cumulative values for rainfall (in mm and hours duration) and total sun hours. During the second year of exposure, ultraviolet radiation was monitored from the change in optical density of polyphenylene oxide films. The mean value for total horizontal ultraviolet radiation for 1974 was 9659 BLEE units (Black Lamp Energy Equivalent (22)). Generally the meteorological data indicate that the conditions during the exposure period were not unusual for the area.

#### 3.2 Visual Changes and Microbiological Examination

Variation of the visual appearance of the tubes after exposure is described in Table 2. Prior to exposure, the glass is only just visible in the translucent composite and the helical winding pattern cannot be seen clearly. After three months exposure of the ground tubes, the pattern of the fibres in the exposed outer surface could be clearly discerned. After 12 months some fibres were largely unsupported on the outside of the tube for a distance extending over about one quarter of the circumference centred about the point of maximum exposure. Figure 3 shows detail of this fibre prominence after 24 months. For periods of exposure over 3 months the tubes showed increasing roughness and the exposed glass was mildly irritating to the skin unless carefully handled.

Microbiological examination of the exposed tubes showed a wide range of organisms growing on and in the tubes including a range of fungi, lichen and some algae. No utilisation of the resin in the metabolism of the organisms or other mode of attack on the system could be detected. Growth occurred preferentially on the rougher surfaces caused by the original grinding, superficial erosion or chalking during exposure, or collected debris. This growth was probably due to improved adhesion on the rougher surface and to greater water retention in these areas. Unexposed cured resin without glass was tested for fungal resistance and showed no detectable utilisation by the standard fungal cultures (23).

### 3.3 Torsional Rigidity

Torsional rigidity values for tubes before and after exposure are given in Table 3.

The results are quoted as values for the rigidity of the tube, not as modulus values, and therefore reflect variations in sample diameter and wall thickness.

The material modulus (G) is related to the tube stiffness (S), for homogeneous materials by the equation :

$$G = \frac{32}{(D^4 - D_o^4)} \cdot S$$

where D is the outside diameter and  $D_o$  is the inside diameter. For ground tubes the estimated modulus from the  $D_o$  above equation is  $5.0 \pm 0.5$  GPa. For as-wound tubes the error introduced in determining the outside diameter is high due to the uneven nature of the surface and the material is macroscopically heterogeneous due to the resin-rich surface. Thus direct calculation of modulus is of little significance.

The standard deviation for as-wound tubes is 0.40 kNm/rad .m and for ground tubes is 0.84. The grinding process appears to have resulted in increased scatter in torsional rigidity. As-wound tubes show excellent reproducibility even though the tube wall thickness was not controlled. This indicates that the outer layer of resin does not contribute significantly to the torsional rigidity. For the ground tubes which are machined to a close tolerance in wall thickness, the scatter indicates a variation introduced during machining. The decrease in torsional rigidity on machining indicates that a portion of the glass was removed during the process. Assuming that the shear modulus of the composite is not affected by grinding and that the resin-rich surface has no effect on rigidity, the effective outside diameter of the as-wound tubes can be calculated using the above equation and the modulus calculated from the ground sample. Such calculations indicate that between 35 and 45% of the glass has been removed. If the modulus of the ground tubes was significantly lower than the effective composite in the unground tubes due to loss of effective reinforcement or if the outer layer of resin in the unground tubes carried a significant proportion of the torque, the calculated value for the amount of glass removed would be reduced.

An estimate of the proportion of glass removed can also be obtained from the geometry of the tube and glass contents before and after grinding. Calculations show that approximately one third of the glass was removed indicating that the assumptions in the calculation from the loss of stiffness are reasonable.

No significant change in torsional rigidity was detected in any tube as a result of weathering.

### 3.4 Burst Pressure

In order to ascertain reproducibility of the test a number of 3.3 m lengths of tube were cut into 300, 450, 600 mm lengths. No significant variation in burst pressure could be attributed to position in the tube or selection of tube. From the results shown in Table 4, it could be suggested that increase of the length of the specimen tends to reduce the apparent burst pressure. This indicates a slight increase in the probability of finding a major flaw as the length is increased.

The burst pressure for 300 mm specimens cut from exposed tubes are shown in Table 5. Ground tubes were cut in half transversely to give replicate specimens, but only a single 150 mm long specimen could be cut from the as-wound tubes due to the machining of the ends. No effect which could be attributed to exposure was detected and observation of the failure mode showed no increased tendency for failure to initiate in the exposed area of the tube.

## 4. DISCUSSION

Torsional rigidity was determined because it is particularly sensitive to variation in the physical properties of the outer layers of a sample. The accuracy of this test is approximately 4%. Thus on a ground specimen it can just detect a loss of 0.05 mm of effective composite (3% of the wall thickness). For an easily observed change of 10% in rigidity 0.15 mm would need to be lost.

Burst pressure determined without using an internal liner tends to result in failure by leaking from isolated weak points is damaged or degraded specimens and, consequently, also should detect any loss of strength due to deterioration. Only one test, after 6 months exposure of a ground tube, showed a low burst pressure caused by leakage from a localised flaw. No significant loss of strength or stiffness has occurred in these tubes during the exposure period.

These results can be contrasted with trials (7,8) where similar systems showed significant reductions in hydrostatic burst pressure using lined cylinders. The results of Day and Readdy (9) are this confirmed and extended to thin wall, unidirectional, helically wound tubes exposed in a tropical environment. The visual degradation observed which leads to the release of irritant glass fibres on contact can be eliminated by the use of a standard coating system. This is usually required in any case, for other purposes. Damage to the surface coating should not initiate significant losses of strength due to moisture ingress to the composite at that point.

In view of the variability of results of weathering of composites reported in the literature (6), it is difficult to generalise about the results reported here. The tubes were exposed unstressed and only a single resin system was studied. The results indicate, however, that composite materials can be produced that are stable under unstressed static conditions in a tropical environment.

## 5. CONCLUSIONS

Samples of as-wound, ground and surface coated epoxy/glass tubes have been exposed in an unstressed condition for two years in the hot-wet conditions at JTRU, Innisfail, North Queensland. No significant deterioration could be detected mechanically although samples modified by grinding showed some loss of superficial glass when examined visually. This minor deterioration could be prevented by the use of a standard alkyd coating.

It is concluded that tropical exposure for at least two years in an unstressed state has little significant effect on the strength of the Australian produced, filament wound, glass-epoxy tube of the M72 A1 launcher.

## 6. ACKNOWLEDGEMENTS

Thanks are due to Explosives Factory, Maribyrnong, Department of Industry and Commerce, for the supply of components and manufacturing data as well as for assistance in the determination of burst pressure.

The assistance of the following groups at MRL is also gratefully acknowledged :

Metallurgical Mechanics Group (Mechanical Properties Section);  
for the measurement of torsional rigidity.

Paints Group (and Government Paint Committee); for advice on  
and application of coatings.

Textiles Group (Mycology Section); for mycological examination  
of exposed tubes.

## 7. REFERENCES

1. Baker, A.A., Ellis, R. and Hutchison, M.M. (1974). "Construction of an Experimental Carbon Fibre Reinforced Plastic Bipod Leg for an 81 mm Mortar Unit". Metallurgy Report 95 and Structures and Materials Report 351, Aeronautical Research Laboratories, Department of Defence, Melbourne, Australia.
2. LeMaistre, C.W. and Irving, R.D. (1975). "Lightweight Composite Tripod". Technical Memo to be published, Weapons Research Establishment, Department of Defence, Salisbury, Australia.
3. McCrum, N.G. (1971). "A Review of the Science of Fibre Reinforced Plastics". Her Majesty's Stationary Office, London, England.
4. Rugger, G.R. and Titus, J.B. (1966). "Weathering of Glass Reinforced Plastics". Plastec Report 24, Plastics Technical Evaluation Center, Picatinny Arsenal, Dover, New Jersey, USA.
5. Matthen, J., Wiechers, M. and Scott, K.A. (1971). "A Review of the Literature on the Ageing and Weathering of Plastics, Pts. 4 and 5". Rubber and Plastics Research Association, Shrewsbury, England.
6. Hiscock, J. (1974). "A Study of the Effect of Environment on the Properties of Glass Reinforced Plastic". Report RP477, Westland Helicopters, Yeovil, England.
7. Bonk, R.B. and Teetsel, D.A. (1971). "Resistance of Plastics to Outdoor Weathering : Glass Filament Wound Epoxies". Tech. Report 2102 Addendum No. 9, Picatinny Arsenal, Dover, New Jersey, USA.
8. Maciejczyk, J., Bonk, R.B. and Levi, D.W. (1973). "Weathering of Composites. I. Review of Epoxide Glass Filament Wound Structures". Tech. Report 4467, Picatinny Arsenal, Dover, New Jersey, USA.
9. Day, L.E. and Readdy, A.F. (1970). "Feasibility of Glass-Filament-Wound Plastics for Army Rocket Motor Cases; Progress Report 9; The Effects of Indoor Storage and Outdoor Weathering on Naval Ordnance Laboratory (NOL) Ring Test Specimens". Tech. Report 3918, Picatinny Arsenal, Dover, New Jersey, USA.
10. Wright, J. (1972). "Outdoor and Accelerated Weathering of Elastomers and Plastics; The Assessment of an Accelerated Test Chamber". Tech. Report 107, Explosives Research and Development Establishment, Waltham Abbey, England.
11. Eakins, W.J. (1969). "Interfaces in Composites". ASTM STP 452, American Society for Testing and Materials, Philadelphia, USA.
12. Broutman, L.J. (1966). Polym. Eng. Sci., 3, 263.
13. Manson, J.A. and Chiu, E.H. (1973). J. Polym. Sci., Polym. Symp., 41, 95.

14. Augl, J.M. (1975). Private communication. Naval Surface Weapons Center, White Oak, Silver Spring, USA.
15. Boseley, D.D., Ebdon, M.P. and Jones, P.G. (1972). "Development of Manufacture of Tube Outer for M72A1 Launcher for Light Anti-Tank Weapons". Work Report 1971/13, Explosives Factory, Maribyrnong, Department of Manufacturing Industry, Maribyrnong, Australia.
16. Oleesky, S.A. and Mohr, J.G. (1964). "Handbook of Reinforced Plastics". Society of Plastics Industry, Reinhold, N.Y., USA.
17. Alumbaugh, R.L. and Rue, T. (Jnr.) (1970). "Reinforced Plastics Laminate Panels - Physical Tests of Panels Removed after the Fourth Exposure Period". Tech. Note N-1084, Naval Civil Engineering Laboratory, Port Hueneme, California, USA.
18. —. (May 1975). Specification "Undercoat for Enamel". GPC-U-23, MRL, Government Paint Committee, Maribyrnong, Australia.
19. —. (May 1975). Specification "Enamel Lustreless Olive-Drab". GPC-E7, MRL, Government Paint Committee, Maribyrnong, Australia.
20. Wycherley, G. (1975). "Report on M72 LAW - Outer Tube Samples". Laboratory Report T74/67, M6-2200, Materials Research Laboratories, Maribyrnong, Australia.
21. —. (1975). "Hydrostatic Pressure Test Equipment - Filament Tubes". Drawing No. 2406/01 and 02 (1975), Materials Research Laboratories, Maribyrnong, Australia.
22. Davis, A., Gordon, D. and Howell, G.V. (1973). "Continuous World-Wide UV Monitoring Programme". Tech. Report 141, Explosives Research and Development Establishment, Waltham Abbey, Essex, England.
23. —. (1972). "Methods of Testing Materials for Resistance to Fungal Growth; Pt. 1: General Principles of Testing". Australian Standard 1157, Pt.1, Standards Association of Australia, Melbourne, Australia.

TABLE 1

METEOROLOGICAL DATA FOR THE TRIAL

PERIOD (a) - JTRU INNISFAIL

| Environmental Factor                        | Withdrawal Period (Mths) |      |      |      |      |
|---|--------------------------|------|------|------|------|
|   | 1                        | 3    | 6    | 12   | 24   |
| <u>Data for Periods Between Withdrawals</u> |                          |      |      |      |      |
| Temperature (°C)                            |                          |      |      |      |      |
| Highest Daily Max.                          | 32                       | 30   | 29.5 | 34   | 37   |
| Average Daily Mean                          | 26.5                     | 24.3 | 21.8 | 25.4 | 21.8 |
| Lowest Daily Min.                           | 21                       | 16   | 13   | 15   | 8    |
| Relative Humidity (%)                       |                          |      |      |      |      |
| Highest Daily Max.                          | 98                       | 98   | 100  | 99   | 100  |
| Average Daily Mean                          | 88                       | 85   | 84   | 85   | 80   |
| Lowest Daily Min.                           | 52                       | 45   | 44   | 25   | 18   |
| <u>Cumulative Data</u>                      |                          |      |      |      |      |
| % Time RH over 70%                          | 93                       | 95   | 90   | 89   | 79   |
| Rainfall (mm)                               | 1021                     | 2031 | 2413 | 5303 | 8489 |
| Duration Rain (h)                           | 168                      | 360  | 487  | 1075 | 1654 |
| Total Sun Hours<br>(Campbell-Stokes)        | 142                      | 421  | 953  | 1916 | 4324 |

(a) February, 1973 - February, 1975

**TABLE 2**  
**VISUAL ASSESSMENT OF TUBES**  
**AFTER 24 MONTHS EXPOSURE**

| Specimen Type     | Fibre Prominence  | Chalking                   | Colour Change   |
|-------------------|-------------------|----------------------------|---|
| As-wound          | No change         | No change                  | Slight yellowing of matrix                                  |
| Ground            | Severe prominence | Not determined             | Not determined  |
| Ground and coated | No change         | Slight chalking of coating | Slight green tinge on coating due to microbiological growth |

**TABLE 3**

**TORSIONAL RIGIDITY OF TUBES**

| Specimen No. | Tube Type       | Torsional Rigidity, kNm/rad. m |         |          |          |           |           |
|--------------|-----------------|--------------------------------|---------|----------|----------|-----------|-----------|
|              |                 | Unexposed                      | 1 month | 3 months | 6 months | 12 months | 24 months |
| 1            | Ground          | 1.87                           | 1.98    |          |          |           | 1.76      |
| 2            | Ground          | 1.68                           |         |          |          |           | 1.81      |
| 3            | Ground          | 1.78                           |         | 1.79     |          |           |           |
| 4            | Ground          | 1.95                           |         | 2.01     |          |           |           |
| 5            | Ground          | 1.94                           |         |          | 1.95     |           |           |
| 6            | Ground          | 2.02                           |         |          |          | 2.05      |           |
| 7            | Ground          | 1.71                           |         |          |          |           | 1.74      |
| 8            | Ground & Coated | 1.89                           |         |          | 1.95     |           |           |
| 9            | Ground & Coated | 1.68                           |         |          |          | 1.52      |           |
| 10           | Ground & Coated | 2.28                           |         |          |          |           | 2.32      |
| 11           | As-wound        | 3.53                           | 3.67    |          |          |           |           |
| 12           | As-wound        | 3.53                           | 3.50    |          |          |           |           |
| 13           | As-wound        | 3.36                           | 3.27    |          |          |           |           |
| 14           | As-wound        | 3.42                           | 3.30    |          |          |           |           |
| 15           | As-wound        | 3.42                           |         |          | 3.53     |           |           |
| 16           | As-wound        | 3.27                           |         |          | 3.47     |           |           |
| 17           | As-wound        | 3.36                           |         |          |          | 3.30      |           |
| 18           | As-wound        | 3.47                           |         |          |          | 3.33      |           |
| 19           | As-wound        | 3.50                           |         |          |          |           | 3.53      |
| 20           | As-wound        | 3.39                           |         |          |          |           | 3.53      |
| 21           | Control, Ground | 2.07                           | 2.12    | 2.07     | 2.18     | 2.10      | 2.11      |

**TABLE 4**  
**SUMMARY OF BURST PRESSURES**  
**OF UNEXPOSED TUBES**

| Length,<br>mm   | Mean<br>Pressure,<br>MPa | Standard<br>Deviation,<br>MPa | No. of<br>Samples |
|-----------------|--------------------------|-------------------------------|-------------------|
| <b>As-wound</b> |                          |                               |                   |
| 300             | 35.8                     | 3.11                          | 10                |
| 450             | 38.0                     | 2.36                          | 4                 |
| 600             | 30.1                     | 1.93                          | 6                 |
| <b>Ground</b>   |                          |                               |                   |
| 600             | 17.0                     | 1.1                           | 6                 |

**TABLE 5**

**HYDROSTATIC BURST PRESSURE OF TUBES**

| Specimen No. | Tube Type       | Hydrostatic Burst Pressure, MPa |              |               |               |
|--------------|-----------------|---------------------------------|--------------|---------------|---------------|
|              |                 | 3 months (a)                    | 6 months (b) | 12 months (b) | 24 months (b) |
| 1            | Ground          |                                 |              |               | 17.2, 17.2    |
| 3            | Ground          | 16.4                            |              |               |               |
| 4            | Ground          | 20.3                            |              |               |               |
| 5            | Ground          |                                 | 7.6, 18.6    |               |               |
| 6            | Ground          |                                 |              | 19.3, 23.4    |               |
| 7            | Ground          |                                 |              |               | 22.0, 17.2    |
| 8            | Ground & Coated |                                 | 21.3, 20.7   |               |               |
| 9            | Ground & Coated |                                 |              | 15.1, 17.9    |               |
| 10           | Ground & Coated |                                 |              |               | 20.0, 20.7    |
| 14           | As-wound        | 21.3 (c)                        |              |               |               |
| 15           | As-wound        |                                 | 38.6         |               |               |
| 16           | As-wound        |                                 | 35.8         |               |               |
| 17           | As-wound        |                                 |              | 39.3          |               |
| 18           | As-wound        |                                 |              | 41.3          |               |
| 19           | As-wound        |                                 |              |               | 37.9          |
| 20           | As-wound        |                                 |              |               | 37.9          |

(a) 600 mm sample tested

(b) 300 mm sample tested

(c) Tube burst in machined end

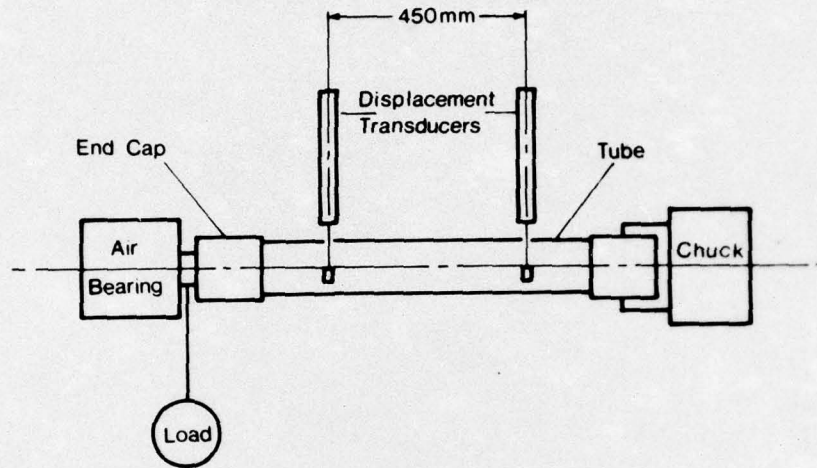

FIGURE 1 - Schematic Diagram of the Apparatus for Determination of Torsional Rigidity (20) (Plan view).

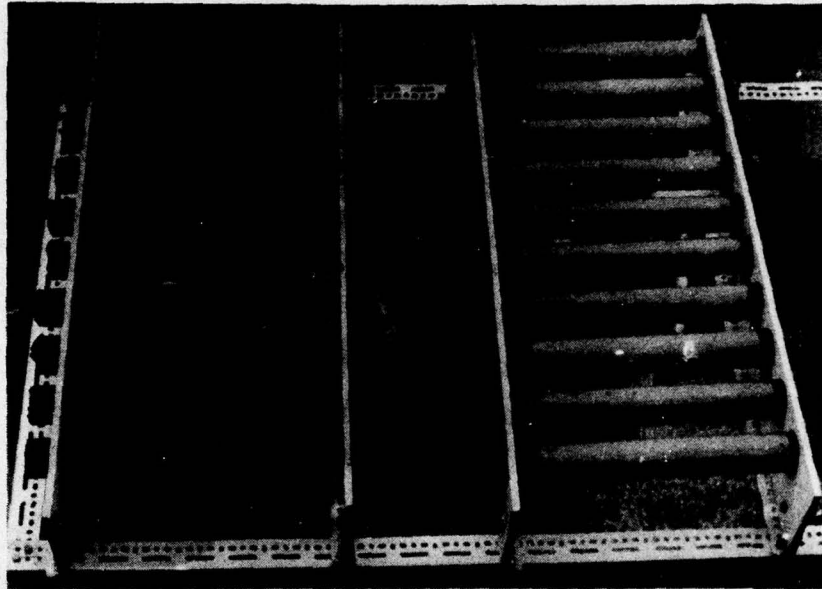

FIGURE 2 - Specimens on Exposure at the Hot-Wet Cleared Site, JTRU, Innisfail.

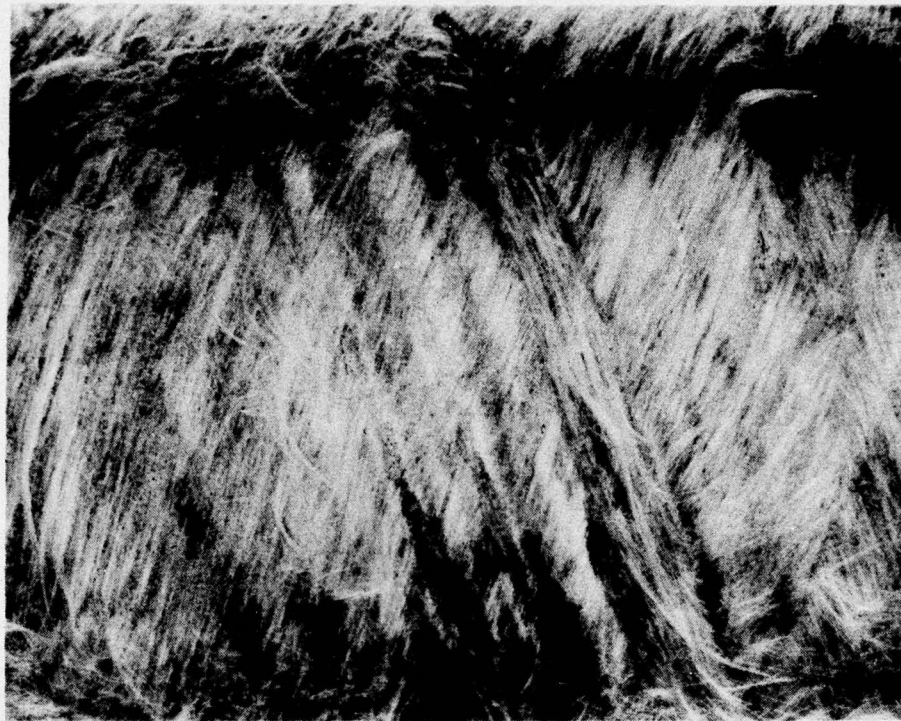

FIGURE 3 - Fibre Prominence on the Surface of a Ground  
Tube After Exposure for 2 years. (x 4 mag)

DISTRIBUTION LIST

MATERIALS RESEARCH LABORATORIES

Chief Superintendent  
Superintendent, Organic Chemistry Division  
Mr. P. Dunn  
Library  
Dr. J.G. Williams  
Branch Superintendent, S.A. Branch  
Librarian, N.S.W. Branch (Through Officer-in-Charge)  
Librarian, S.A. Branch  
Officer-in-Charge, Joint Tropical Research Unit

DEPARTMENT OF DEFENCE

Chief Defence Scientist (2 copies)  
Executive Controller, ADSS  
Superintendent, Central Studies Establishment  
Superintendent, Defence Science Administration, DSTO  
Head, Laboratory Programs Branch  
Army Scientific Adviser  
Air Force Scientific Adviser  
Naval Scientific Adviser  
Chief Superintendent, Aeronautical Research Laboratories (3 copies)  
(1 copy - Attention: Dr. M. Hutchison)  
(1 copy - Attention: Dr. A.A. Baker)  
Director, Weapons Research Establishment (2 copies)  
(1 copy - Attention: Dr. J. Baxter, WR & D Wing)  
Senior Librarian, Weapons Research Establishment  
Librarian, R.A.N. Research Laboratory  
Document Exchange Centre (14 copies)  
Directorate of Quality Assurance (Air Office)  
Chief Superintendent, Engineering Development Establishment  
Director of Equipment (Army Office)  
Principal Librarian, Campbell Park Library ADSATIS Annex

DEPARTMENT OF MANUFACTURING INDUSTRY

Principal Librarian, Central Office Library  
NASA Canberra Office  
Head, B.D.R.S.S. (Aust.)  
Controller (Munitions Supply)  
Manager, Explosives Factory, Maribyrnong  
Manager, Small Arms Factory, Lithgow

OTHER FEDERAL AND STATE DEPARTMENTS AND INSTRUMENTALITIES

The Chief Librarian, Central Library, C.S.I.R.O.  
Australian Atomic Energy Commission Research Establishment,  
(Attention: Library)

(MRL REPORT 662)

DISTRIBUTION LIST

(Continued)

MISCELLANEOUS - OVERSEAS

Senior Representative, Department of Manufacturing Industry,  
England  
Dr. C.L.M. Cottrell, Assistant Director/Armour & Materials,  
Military Vehicles & Engineering Establishment, England  
Reports Centre, Directorate of Materials Aviation, England  
Chief, Accessioners Division, Defence Documentation Center,  
USA (2 copies)  
Library - Exchange Desk, National Bureau of Standards, USA  
U.S. Army Standardization Group, Office of the Scientific  
Standardization Representative, Canberra, A.C.T.  
Senior Standardization Representative, U.S. Army Standardization  
Group, Canberra, A.C.T.  
Chief, Research and Development, Defence Scientific Information  
Service, Canada (2 copies)  
The Director, Defence Scientific Information & Documentation  
Centre, India  
Colonel B.C. Joshi, Military, Naval and Air Adviser, High  
Commission of India, Red Hill, A.C.T.  
Director, Defence Research Centre, Malaysia  
Exchange Section, British Library, England  
Official Publications Section, British Library, England  
Librarian, Periodicals Recording Section, National Reference  
Library of Science and Invention, England  
INSPEC: Acquisition Section, Institution of Electrical Engineers,  
England  
Overseas Reports Section, Defence Research Information Centre,  
England  
Director, Explosives Research and Development Establishment,  
England  
Director, Royal Aircraft Establishment, England  
Director General, Defence Research Establishment Ottawa, Canada.