

AD-A033 051

NATIONAL AVIATION FACILITIES EXPERIMENTAL CENTER ATL--ETC F/G 1/3
AIRCRAFT CABIN COMPARTMENTATION CONCEPTS FOR IMPROVING POSTCRAS--ETC(U)
OCT 76 R HILL, P N BORIS, G R JOHNSON

UNCLASSIFIED

FAA-NA-76-12

FAA-RD-76-131

NL

1 OF 1
AD A033051



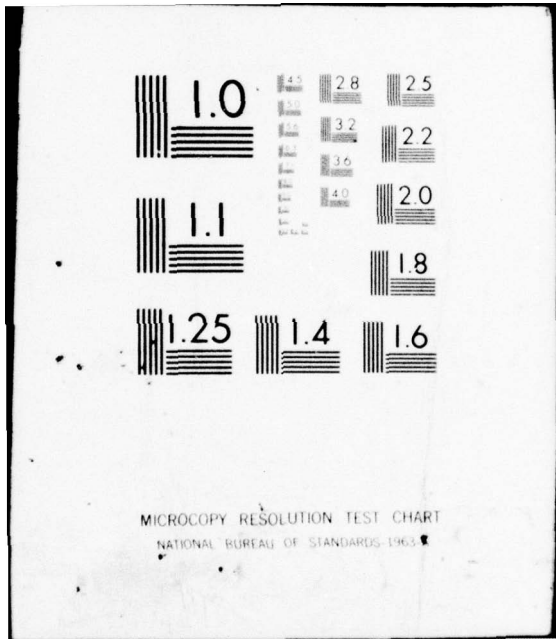

MICROCOPY RESOLUTION TEST CHART
NATIONAL BUREAU OF STANDARDS-1963-A

Report No. FAA-RD-76-131

(12)
NA

**AIRCRAFT CABIN COMPARTMENTATION CONCEPTS
FOR IMPROVING POSTCRASH FIRE SAFETY**

ADA 033051

**Richard Hill
Paul N. Boris
George R. Johnson**



D D C
RECEIVED
DEC 7 1976
C
[Handwritten signature]

OCTOBER 1976

FINAL REPORT

Document is available to the public through the
National Technical Information Service
Springfield, Virginia 22151

Prepared for

**U. S. DEPARTMENT OF TRANSPORTATION
FEDERAL AVIATION ADMINISTRATION
Systems Research & Development Service
Washington, D.C. 20590**

NOTICE

This document is disseminated under the sponsorship of the Department of Transportation in the interest of information exchange. The United States Government assumes no liability for its contents or use thereof.

1. Report No. 18 FAA-RD-76-131 19	2. Government Accession No.	3. Recipient's Catalog No.	
6. Title and Subtitle AIRCRAFT CABIN COMPARTMENTATION CONCEPTS FOR IMPROVING POSTCRASH FIRE SAFETY		11. Report Date October 1976	12. Performing Organization Code
7. Author(s) Richard Hill, Paul N. Boris, and George R. Johnson		14. Performing Organization Report No. FAA-NA-76-12	174p.
9. Performing Organization Name and Address Federal Aviation Administration National Aviation Facilities Experimental Center Atlantic City, New Jersey 08405		10. Work Unit No. (TRAIS)	
12. Sponsoring Agency Name and Address U.S. Department of Transportation Federal Aviation Administration Systems Research and Development Service Washington, D.C. 20590		11. Contract or Grant No. 181-521-000	
15. Supplementary Notes		13. Report and Period Covered 9. Final Rept. Jan 1975 - Jan 1976	
16. Abstract Aircraft cabin compartmentation was investigated as a means of increasing escape time for passengers during a postcrash cabin fire. The size and configuration of various partitions and/or 'curtains were investigated to determine their effectiveness in providing protection from a cabin fire by limiting the spread of heat, smoke, carbon monoxide (CO), and the depletion of oxygen from the vicinity of the fire to other areas of the cabin. The results of these tests indicated that a tightly sealed partition and/or curtain afforded the greatest protection from the spread of a given amount of heat, smoke, CO, and depletion of oxygen. The results also indicated that the use of compartmentation can adversely affect the intensity of a fire in an unclosed area, creating more products of combustion. Except for a limited number of cases, the amount of protection provided by the partition exceeded the increase in fire intensity.			
17. Key Words Aircraft Fires Aviation Safety Fire Safety Postcrash Cabin Fire Compartmentation		18. Distribution Statement Document is available to the public through the National Technical Information Service, Springfield, Virginia 22151	
19. Security Classif. (of this report) Unclassified	20. Security Classif. (of this page) Unclassified	21. No. of Pages 74	22. Price

240550

JP

TABLE OF CONTENTS

	Page
INTRODUCTION	1
Purpose	1
Background	1
DISCUSSION	1
Equipment Description and Configuration	1
List of Instrumentation	7
Test Description and Procedure	7
Discussion of Results	13
Series I	13
Series II	17
Series III	30
Series IV	30
Series V	47
Series VI	47
Summation	55
SUMMARY OF RESULTS	64
CONCLUSIONS	65
REFERENCES	66

ADMISSION for

NTB	White Section	<input checked="" type="checkbox"/>
DCS	Buff Section	<input type="checkbox"/>
UNANNOUNCED JUSTIFICATION		
BY _____		
DISTRIBUTION/AVAILABILITY CODE		
Dist.	Avail. Code	or 2nd Class
R		

LIST OF ILLUSTRATIONS

Figure		Page
1	DC7 Test Article	2
2	Component and Instrumentation Location (Protected Section)	4
3	Component and Instrumentation Location (Fire Load Section)	5
4	Fire Load Rack	6
5	Partition and Curtain Configurations (4 Pages)	11
6	Foam-to-Seats Equivalence	16
7	Large-Fire Temperature Levels (Five Foam Panels)	18
8	Large-Fire Oxygen Levels (Five Foam Panels)	19
9	Large-Fire CO Levels (Five Foam Panels)	20
10	Large-Fire Smoke Levels (Five Foam Panels)	21
11	Curtain Installation	22
12	Temperature Levels Using Two Foam Panels (No Airflow)	23
13	Oxygen Levels Using Two Foam Panels (No Airflow)	24
14	CO Levels Using Two Foam Panels (No Airflow)	25
15	Smoke Levels Using Two Foam Panels (No Airflow)	26
16	Temperature Levels Using Two Foam Panels (2,800 ft ³ /min Airflow)	28
17	Smoke Levels Using Two Foam Panels (2,800 ft ³ /min Airflow)	29
18	Temperature Levels (Airflow Through Door Exit)	31
19	Smoke Levels (Airflow Through Door Exit)	32
20	Minimum Aisle Width per Federal Aviation Regulation (FAR 25.815)	33
21	Temperature Levels Using FAR Partition (No Airflow)	34

LIST OF ILLUSTRATIONS (Continued)

Figure		Page
22	Oxygen Levels Using FAR Partition (No Airflow)	35
23	Smoke Levels Using FAR Partition (No Airflow)	36
24	Temperature Levels Using FAR Partition (2,800 ft ³ /min Airflow)	37
25	Smoke Levels Using FAR Partition (2,800 ft ³ /min Airflow)	38
26	Curtain Halfway Down	40
27	Temperature Levels with Seats Installed at Partition	41
28	Smoke Levels with Seats Installed at Partition	42
29	Temperature Range Between Aft and Forward (No Airflow)	43
30	Smoke Range Between Aft and Forward (No Airflow)	44
31	Temperature Levels with Seats Installed at Partition (2,800 ft ³ /min Airflow)	45
32	Temperature Levels Far Forward (2,800 ft ³ /min Airflow)	46
33	Smoke Levels with Seats Installed at Partition (2,800 ft ³ /min Airflow)	48
34	Smoke Levels Using 18-Inch Header	49
35	Decorative-Type Partition	50
36	Temperature Levels Using Decorative Partition (No Airflow)	51
37	Oxygen Levels Using Decorative-Type Partition (No Airflow)	52
38	CO Levels Using Decorative-Type Partition (No Airflow)	53
39	Smoke Levels Using Decorative-Type Partition (No Airflow)	54
40	Temperature Levels Using Decorative-Type Partition (2,800 ft ³ /min Airflow)	56

LIST OF ILLUSTRATIONS (Continued)

Figure		Page
41	Oxygen Levels Using Decorative-Type Partition (No Airflow)	57
42	CO Levels Using Decorative-Type Partition (2,800 ft ³ /min Airflow)	58
43	Smoke Levels Using Decorative-Type Partition (2,800 ft ³ /min Airflow)	59
44	Heat and Smoke Protection (No Airflow)	60
45	Heat and Smoke Protection with 2,800 ft ³ /min Airflow (Including Change in Fire Dynamics)	61
46	Heat and Smoke Protection with 2,800 ft ³ /min Airflow (Excluding Change in Fire Dynamics)	62

INTRODUCTION

PURPOSE.

This project was part of a research and development program by the Federal Aviation Administration (FAA) to increase passenger survival time following a postcrash fire. More specifically, this project evaluates the protection from the hazards of an internal cabin fire using various cabin compartmentation concepts.

BACKGROUND.

The cabin environment ensuing an aircraft postcrash fire is obviously hazardous to life, but can also impede rescue attempts and inhibit or incapacitate occupants from escaping. For the purpose of clarification, the discussion in this report is predicated upon a "survivable" aircraft accident, i.e., where the fuselage remains substantially intact, and there are minimal disabling injuries to the occupants.

The concept of cabin compartmentation has been studied by the Aerospace Industries Association of America, Inc. (AIA) (Report No. AIA CDP-2) (reference 6) and to a lesser extent by NAFEC (Report No. FAA-RD-70-81) (reference 7). The AIA tests, using a 727 fuselage with a fuel fire entering a simulated rupture, demonstrated that a partition with a closed curtain would significantly reduce smoke and toxic gases and eliminate flame propagation throughout the protected section of a passenger cabin during a crash fire. Compartmentation was one of the few fire protection concepts recommended for further study by the AIA. The previous tests at NAFEC were conducted in a small trailer (640 ft³) and demonstrated that a 37-inch curtain hung from the ceiling was effective in shielding the upper part of the trailer from flash-fire propagation.

DISCUSSION

EQUIPMENT DESCRIPTION AND CONFIGURATION.

The test article used during this project was a DC7 fuselage (figure 1). The test section of the fuselage consisted of two areas, one being protected from the fire by the partition or curtain, and the other the fire source section. The protected section was approximately 2,200 cubic feet in volume and was located between stations 260 and 596. The extreme forward end of the protected section, which housed the instrumentation, was isolated from the test area by an aluminum bulkhead containing three plexiglass windows and a removable door. The door provided access during test preparation and was sealed prior to test commencement. Two of the three windows were used as camera locations for 16 millimeter (mm) film and video tape and the third for visual observation. The other end of the protected section was separated from the fire source section by various configurations of partitions and/or curtains. The protected

- THERMOCOUPLES
- ◇ CO & O₂ PICKUP AREAS
- SMOKEMETER PICKUP AREAS
- ▨ OVER WING ESCAPE HATCHES

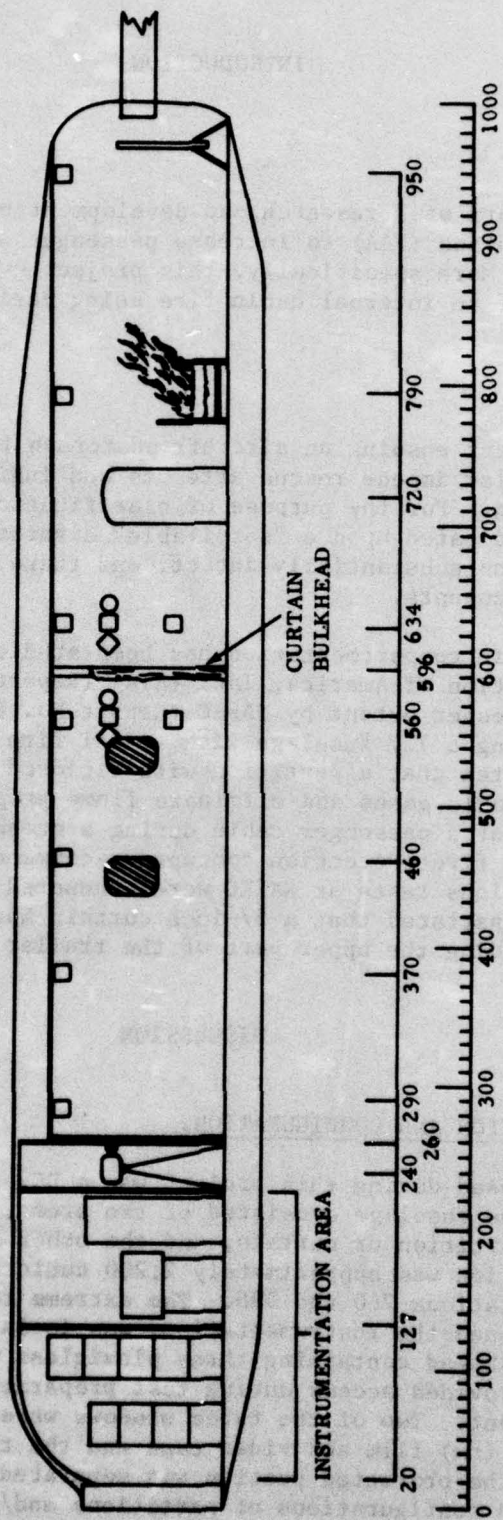

76-12-2

FIGURE 1. DC7 TEST ARTICLE

section was insulated with a Kaowool[®] fiberglass fabric composite protecting the ceiling, and fiberglass fabric covering the sidewalls and hatrack. This section also contained four over-the-wing emergency exits (figure 2), two on each side, which were fully open during all of the test. Wind breaks, consisting of aluminum boxes with the bottoms open, were installed over each of the exits to minimize the effect of ambient wind. Each of the four exits was 25 inches high and 21 inches wide.

Instrumentation in the protected section (forward section) consisted of six chromel alumel thermocouples, located as shown in figures 1 and 2, one oxygen (O_2) and carbon monoxide (CO) sample line located 3 feet forward of the curtain, 5-feet 6-inches from the floor in the center of the aisle, and one sample line at the same location for measuring smoke density. Other equipment in the protected section included an exit sign located on the test partition, a clock for timing the tests on film, and lights for photography.

The fire section (aft section) of the fuselage, located between stations 596 and 978 (figure 3), was separated from the protected section by the test partition and/or curtain. A solid aluminum partition formed the aft bulkhead of the fire section at station 978. The bulkhead was covered with Kaowool and fiberglass cloth for fire and heat protection. The aft bulkhead also contained the opening for the air duct which directed air into the fire section of the fuselage, simulating wind effects through an open exit or rupture. During all airflow tests, except those with the rear entrance door open, a 2,800 ft^3/min airflow was used. A 2,800 ft^3/min airflow represents the airflow created by a 1.8-mi/h wind blowing in an open 6-foot by 3-foot exit or an 8.8-mi/h wind through a 21- by 25-inch opening. This rate of airflow was maintained by a calibrated orifice in the inlet duct and straightened by a number of small tubes in the inlet duct, just prior to discharging into the test section. A baffle was placed 1 foot in front of the duct exit in order to equalize distribution of the air throughout the fire test section and avoid direct impingement on the fire.

The side walls and ceiling of the fire section were lined with Kaowool and fiberglass cloth and a thin (0.016 inch) titanium sheet directly over the fire load to minimize fire damage to the test article. Untreated urethane foam, with a density of 1.5 lb/cu ft, was used during this test program with each slab, 36 by 36 by 4 inches. A metal fire-load rack was constructed to hold the test foam in either a horizontal or vertical position (figure 4). A catch pan, located under the rack, protected the floor under the fire load with additional protection provided by asbestos hardboard which covered the entire fire section floor. A small trough was located at the base of the rack with spark ignition leads at one end to ignite a small quantity of fuel (2 oz.) which, in turn, ignited the foam.

Instrumentation in the fire section of the fuselage included five thermocouples at various locations, and sample lines, 3 feet aft of the curtain, 5 feet 6 inches from the floor in the center of the aisle, for monitoring O_2 , CO , and smoke density (figure 3).

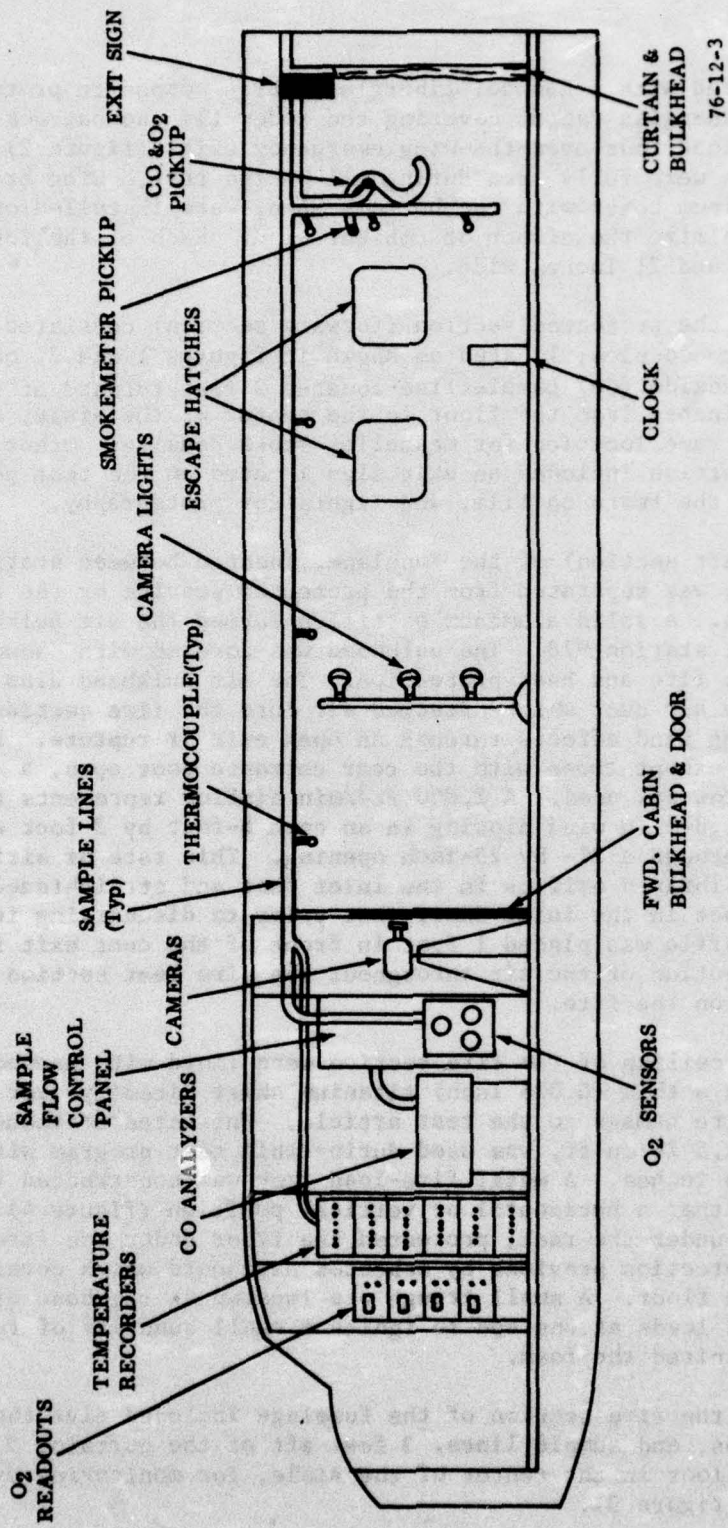
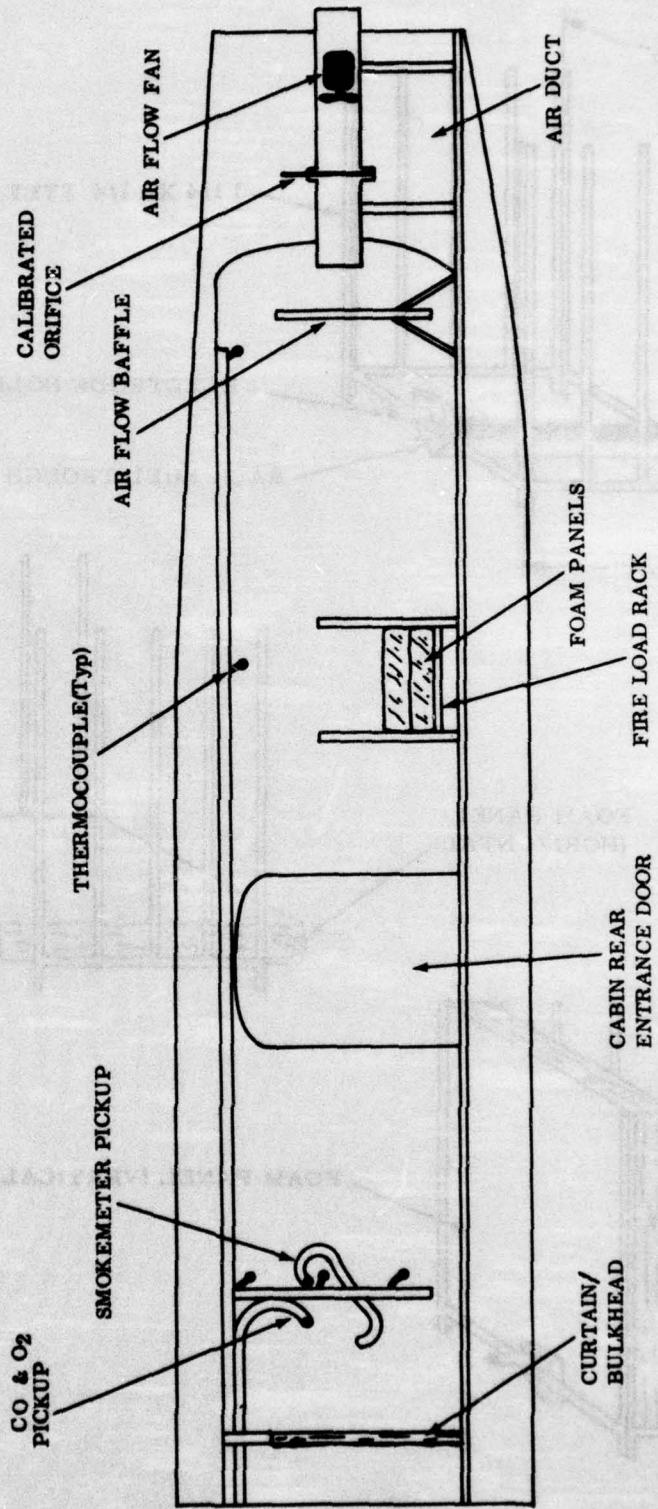

FIGURE 2. COMPONENT AND INSTRUMENTATION LOCATION (PROTECTED SECTION)



76-12-5

FIGURE 3. COMPONENT AND INSTRUMENTATION LOCATION (FIRE LOAD SECTION)

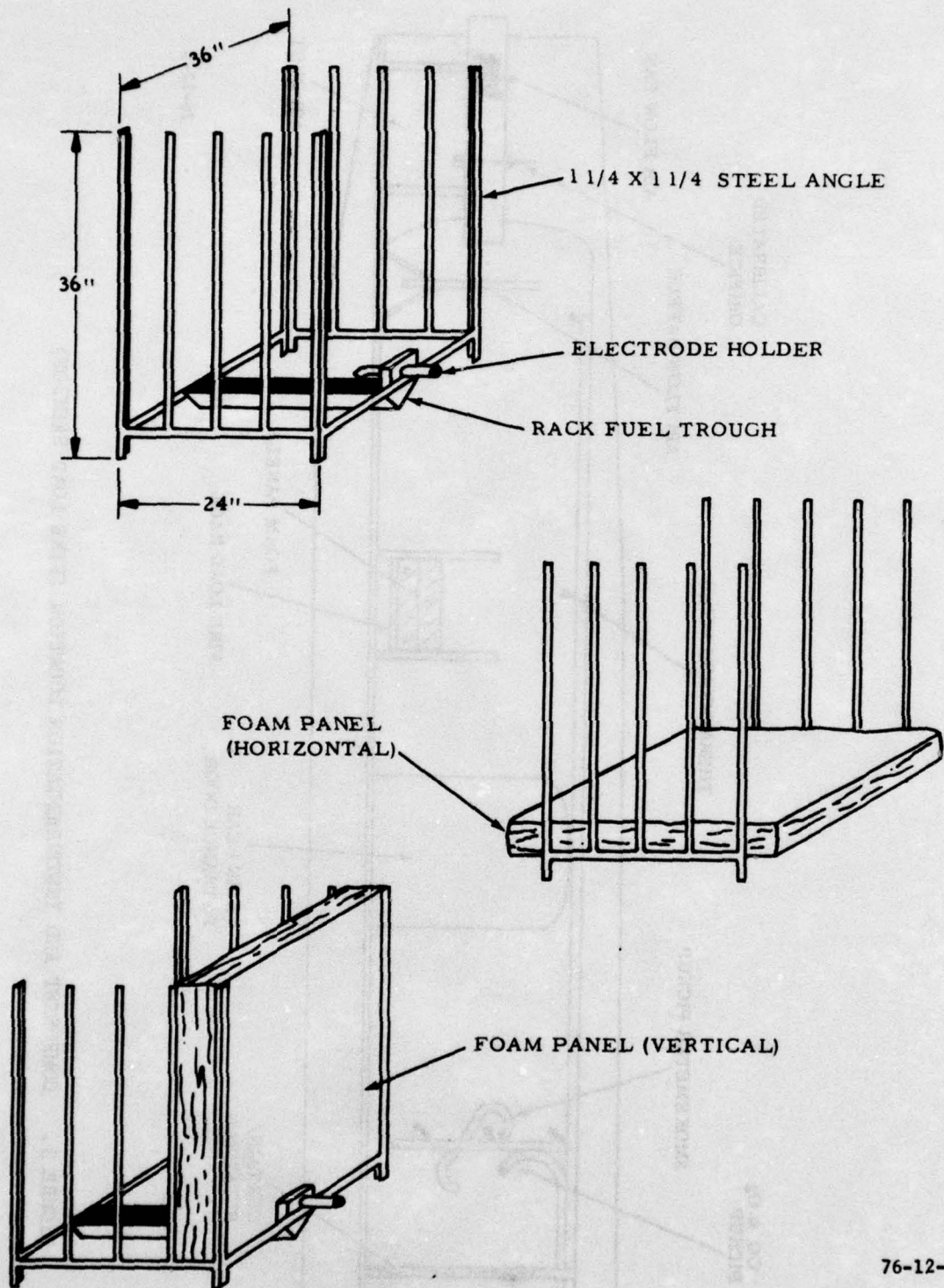

FIGURE 4. FIRE LOAD RACK

The partition and/or curtain configuration was varied during the test program and will be discussed during the analysis of each test phase. All partitions used were constructed of aluminum and the curtains were made of Kynol[®] cloth.

LIST OF INSTRUMENTATION.

TEMPERATURE MONITORING. Cabin temperature measurements were accomplished utilizing eleven (11) chromel/alumel (type K) Ceramo[®] thermocouples, with temperature information permanently recorded on an Esterline-Angus model D-2020 digital data acquisition recorder (see figure 1).

OXYGEN MEASUREMENTS. Oxygen concentration information was obtained by passing a continuous sample of cabin atmosphere through two Beckman model 715 process oxygen monitor sensors, which measured the sample oxygen concentration by the diffusion of oxygen through a gas-permeable membrane exposed to the sample stream (see figure 1). These data were also recorded on the Esterline-Angus digital recorder.

CARBON MONOXIDE MEASUREMENTS. Carbon monoxide (CO) concentrations were monitored by passing a continuous sample of cabin atmosphere through two Beckman model 864 infrared analyzers, where the flowing mixtures were analyzed to determine the concentration of CO. The analysis was based on a differential measurement of the absorption of infrared energy. This information was also recorded on the Esterline-Angus digital recorder (see figure 1).

SMOKE MEASUREMENTS. Cabin smoke concentration information was obtained by drawing samples of cabin atmosphere through two 1-foot-long cylinders, each containing a 3 V d.c. bulb in one end and a Weston model 856 type 1 photocell in the opposite end. The amount of light transmission over this 1-foot space was thus measured. The cylinders were mounted external to the aircraft. Smoke information was also recorded on the Esterline-Angus recorder (see figure 1).

VIDEO COVERAGE. All tests were observed and permanently recorded utilizing a Sony AVC-3400 television camera and an AV-3400 videocorder[®].

TEST DESCRIPTION AND PROCEDURE.

During this test program a total of 37 tests were conducted (see table 1). These 37 tests can be broken down into six distinct series. Series No. 1 consisted of tests 1, 2, 3, and 8 and was the only series using five panels of urethane foam as the fire load. An aluminum partition with an 80-inch by 32-inch opening was installed during this series (refer to figure 5 for all configurations). Series No. 2 used the same partition configuration; however, the fire load was reduced to two panels of foam. This was the longest series of tests, comprising tests Nos. 4 through 15 inclusive, except test No. 8.

All remaining series of tests (except test No. 26) used two panels of foam as the fire load. The four tests in series 3 differed from series 2 in that the size of the opening in the partition was 80 inches high and 20 inches wide above 25 inches from the floor, and 15 inches wide below 25 inches from the floor. This is the minimum aisle width per FAR 25.815 (figure 5B).

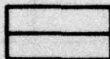

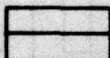

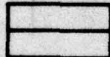

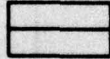

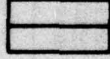

TABLE 1. TEST CONFIGURATION

TEST NUMBER	FIRE LOAD	AIRFLOW (ft ³ /min)	PARTITION CONFIGURATION	TEST NUMBER	FIRE LOAD	AIRFLOW (ft ³ /min)	PARTITION CONFIGURATION
1				9			
2		2800		10			
3				11		2800	
4				12			
5		2800		13			
6		2800		14			
7				15			
8				16			

TABLE 1. TEST CONFIGURATION (Continued)

TEST NUMBER	FIRE LOAD	AIRFLOW (ft ³ /min)	PARTITION CONFIGURATION	TEST NUMBER	FIRE LOAD	AIR FLOW (ft ³ /min)	PARTITION CONFIGURATION
17			M/A/W CURTAIN CLOSED 	25		2800	CURTAIN TO FLOOR AFT OF SEATS
18		2800	M/A/W CURTAIN CLOSED 	26			3" HEADER
19		2800	M/A/W CURTAIN OPEN 	27		2800	3" HEADER
20			TWO PASSENGER SEATS 	28		2800	18" HEADER
21		2800	TWO PASSENGER SEATS 	29			18" HEADER
22			CURTAIN ROLLED ACROSS SEAT TOPS 	30			DECORATIVE PANELS
23		2800	CURTAIN ROLLED ACROSS SEAT TOPS 	31		2800	DECORATIVE PANELS
24			CURTAIN TO FLOOR AFT SEATS 	32			DECORATIVE PANELS SIDES CLOSED

TABLE 1. TEST CONFIGURATION (Continued)

TEST NUMBER	FIRE LOAD	AIRFLOW (ft ³ /min)	PARTITION CONFIGURATION
33		2800	 DECORATIVE PANELS SIDES CLOSED
34			 DECORATIVE PANELS TOP & SIDES CLOSED
36		2800	 DECORATIVE PANELS TOP & SIDES CLOSED
36			 DECORATIVE PANELS COMPLETELY CLOSED
37			 DECORATIVE PANELS CLOSED & CURTAIN OPEN

CABIN DIMENSIONS

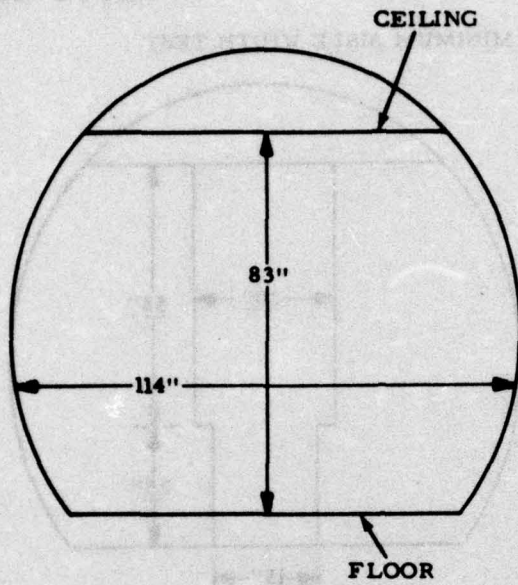

A

TEST #1 - #2 -
#10 - #11 - #12

PARTITION

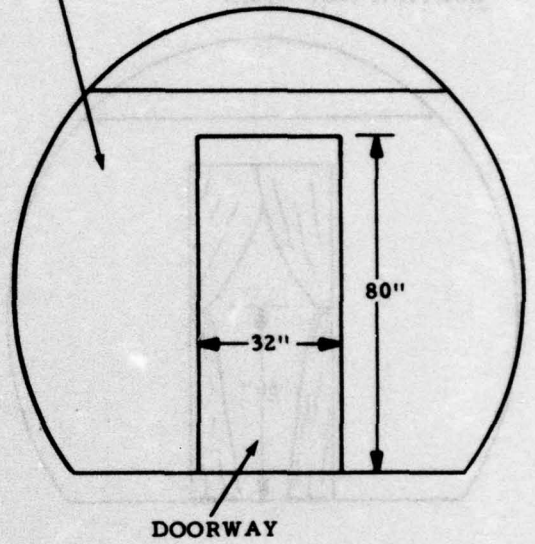

B

CURTAIN
FULL CLOSED

TEST #3-#4-#5
#6-#7-#8
#13-#15
#36

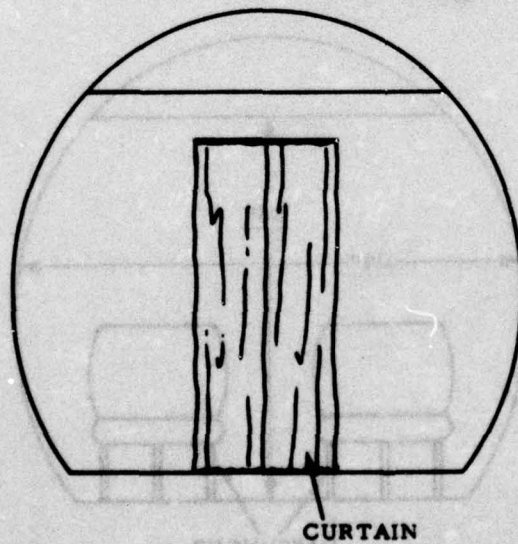

C

CURTAIN
PARTIAL OPEN

TEST #9

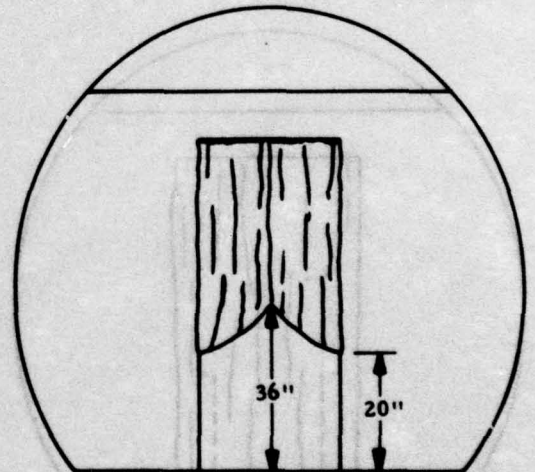

D

76-12-8A

FIGURE 5A. PARTITION AND CURTAIN CONFIGURATIONS (SHEET 1 OF 4)

TEST #14

CURTAIN TIED OPEN

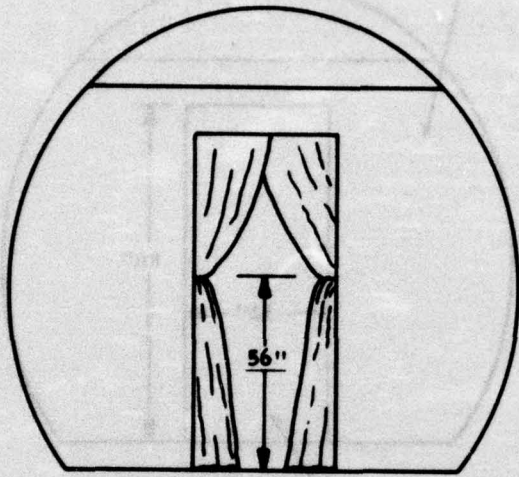

E

TEST #16 - #19

MINIMUM AISLE WIDTH TEST

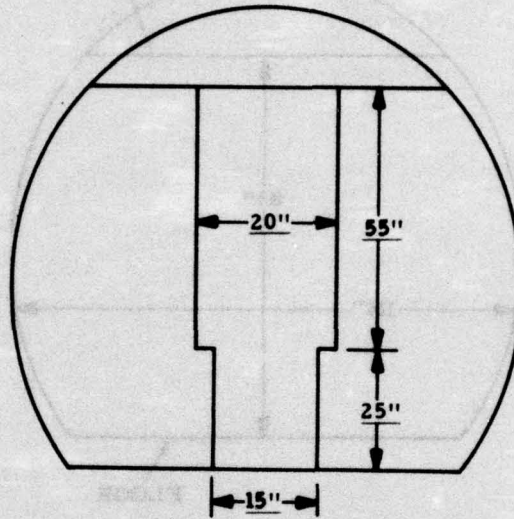

F

TEST #17 - #18

CURTAIN CLOSED

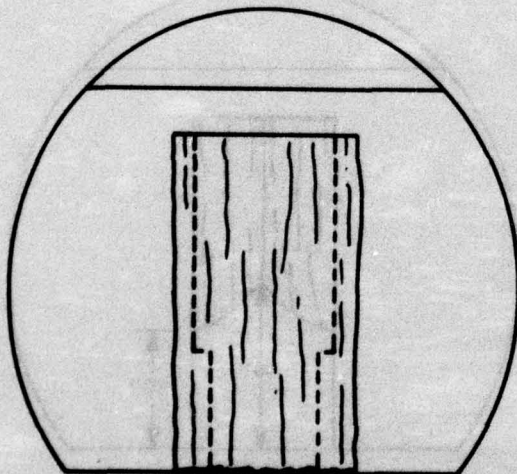

G

TEST #20 - #21

NO PARTITION

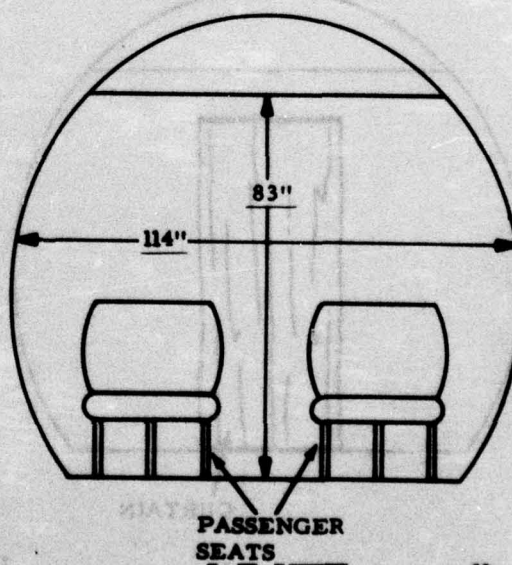

H

76-12-88

FIGURE 5B. PARTITION AND CURTAIN CONFIGURATIONS (SHEET 2 OF 4)

The fourth series consisted of six tests (tests 20 through 25). For this series, the aluminum partition was completely removed and a row of seats and curtains was installed. The use of a curtain alone was evaluated during this series.

Series No. 5 evaluated various header configurations: tests 26 and 27 involved a 3-inch header, and tests 28 and 29 an 18-inch header (figure 5C).

The final eight tests of the program (series 6) evaluated the effectiveness of decorative-type partitions, the variable being the openings on the top, sides, and bottom (figure 5D).

Each of these series contained tests with and without airflow, and as later described, curtains, seat, and partition combinations.

Prior to each test, all instrumentation was calibrated and checked out. Two ounces of aviation fuel placed in the trough under the fire load served as an ignition source. When five panels of foam were used, it was necessary to extinguish the fire after 3 minutes, using CO₂; when two panels were used, the fire load was completely consumed in approximately 3 minutes.

DISCUSSION OF RESULTS.

Before actual discussion of test results, a few prefacing comments should be made. The times to reach certain levels of smoke, CO, temperatures, etc., are dependent upon the fire size. These times should be used to compare test results, but not necessarily be related to the actual escape time during a postcrash ground fire situation. Additionally, the fire dynamics vary with and without airflow, making comparisons between the two difficult. An important aspect to keep in mind is that the resultant products of combustion of any fire is a function of the fuel and fire dynamics. Therefore, the relative quantities between various tests in evaluating the compartmentation concepts are of more concern during this program, rather than absolute quantities. In order to best evaluate the partition and curtain configurations, the data from the forward section of the fuselage are compared with that from the forward section for other tests, and the same approach is taken for comparison in the aft section. Less emphasis is placed on the comparison of data on the protected and fire side of the curtain/partition for any particular test, since any vertical partition between fire and nonfire zones tends to affect fire dynamics. A better understanding of curtain/partition effectiveness can be gained by comparing data at any particular point with that from the same point of another test.

SERIES I.

For this first series of tests (1, 2, 3, and 8), an aluminum partition with a 32-inch/80-inch opening separated the fire zone from the protected zone. All four tests in this series used a fire load of five pieces of foam (figure 6), and because of the severity of the fire, this was the only series using this quantity of foam. A comparison of the effectiveness of a curtain in the doorway and the effect of sealing a curtain with no forced airflow through the fuselage, can be seen by comparing tests No. 1, 3, and 8.

TEST #22 - #23

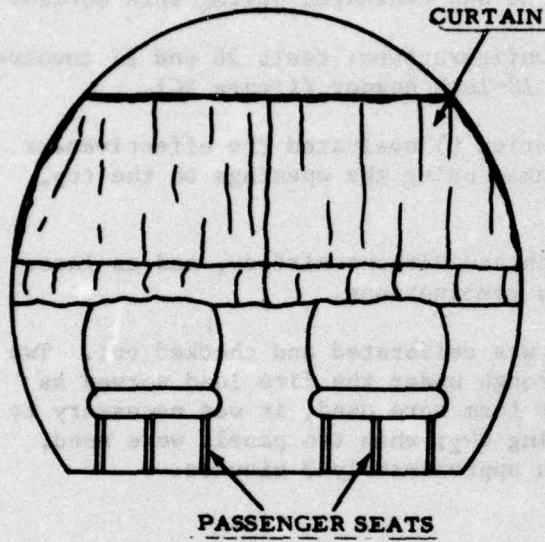

I

TEST #24 - #25

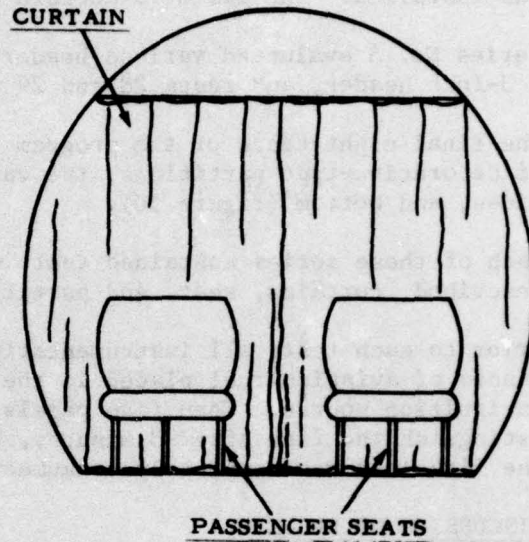

J

TEST #26 - #27

ALL COMPONENTS REMOVED

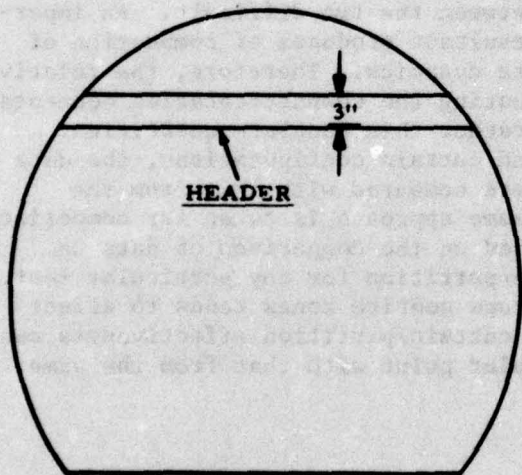

K

TEST #28 - #29

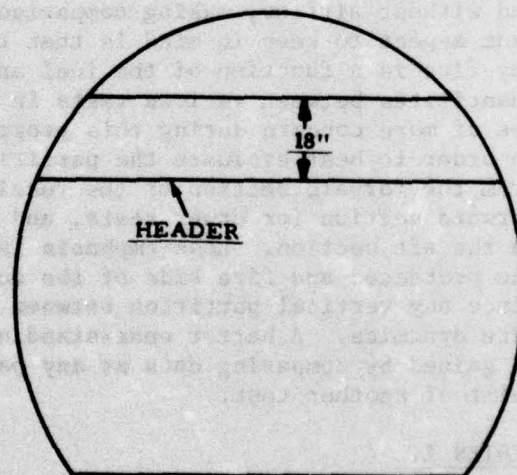

L

76-12-8C

FIGURE 5C. PARTITION AND CURTAIN CONFIGURATIONS (SHEET 3 OF 4)

TEST #30 - #31

X = OPEN AREAS

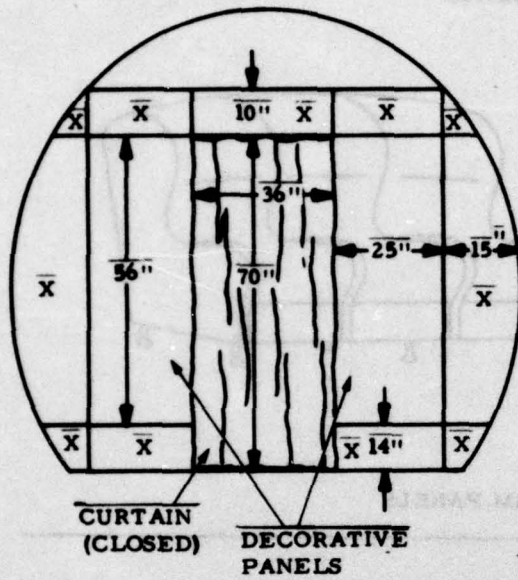

TEST #32 - #33

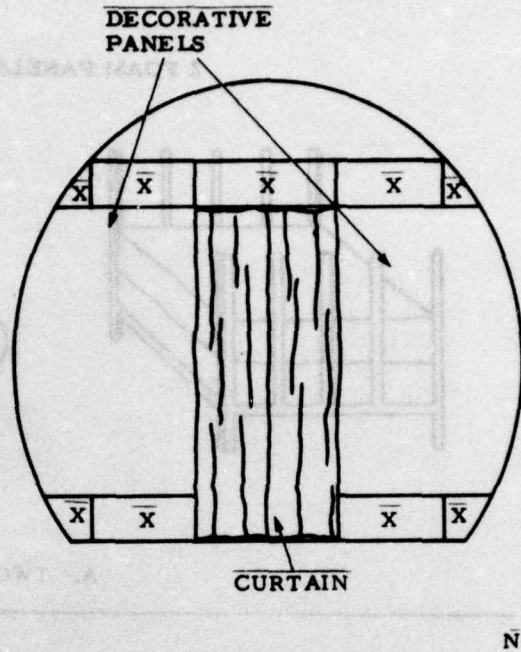

TEST #34 - #35

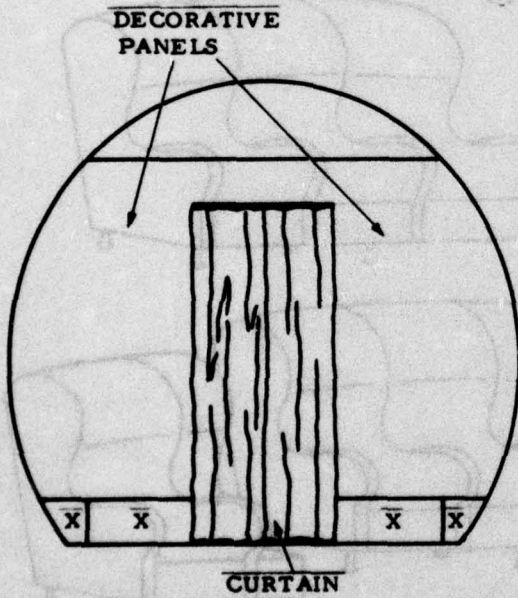

TEST #37

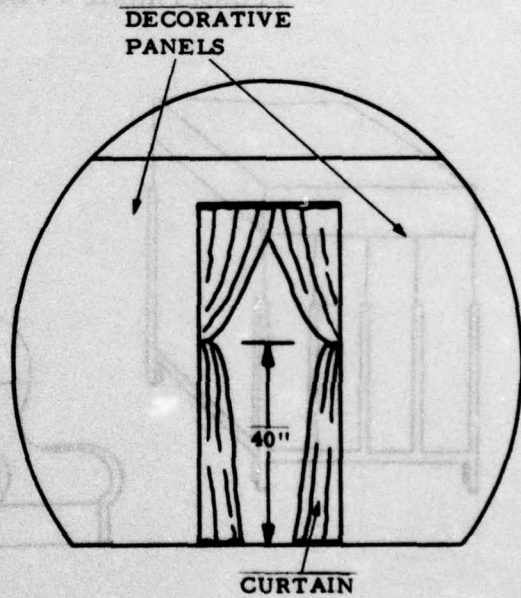

76-12-80

FIGURE 5D. PARTITION AND CURTAIN CONFIGURATIONS (SHEET 4 OF 4)

2 FOAM PANELS = 3 SEATS

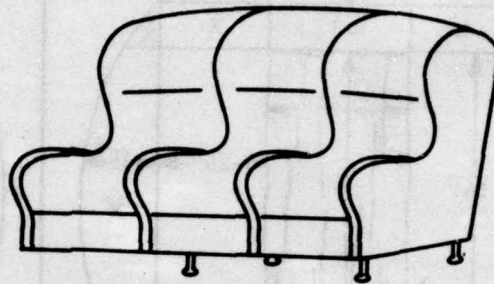
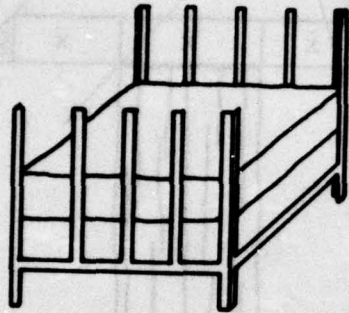

A. TWO FOAM PANELS

5 FOAM PANELS = 7 1/2 SEATS

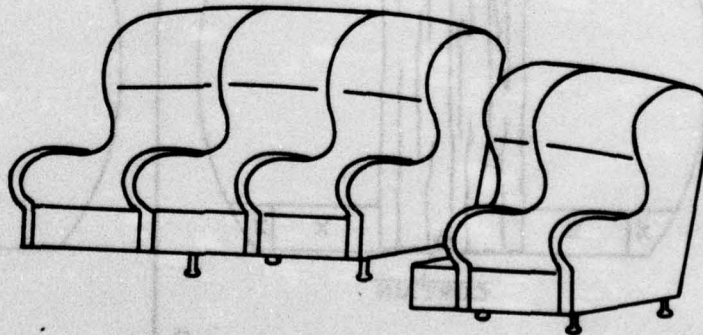
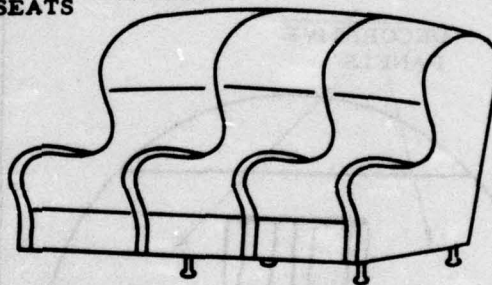
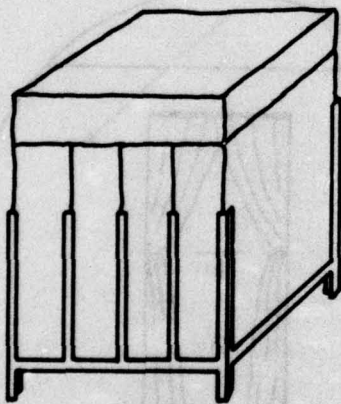

B. FIVE FOAM PANELS

76-12-9

FIGURE 6. FOAM-TO-SEATS EQUIVALENCE

Figure 7 shows the comparison of temperatures at approximate eye level (66 inches from floor) 3 feet on either side of the partition; figure 7A being the protected side and figure 7B the fire side of the partition. Protection from temperature was afforded by a curtain, added protection was gained by sealing the curtain. The rise and peak temperatures were greater in the fire zone when no curtain was installed. Figure 8 represents the oxygen concentration at eye level, 3 feet on either side of the partition. The oxygen-measuring equipment indicates an approximate 20-second delay in response. A correction for response time was not made in preparing the data.

The temperature for test Nos. 3 and 8 becomes steady with time at about 120 seconds. The response time for the oxygen-measuring equipment also becomes steady at approximately the same time during the test. The dense smoke precluded visual observation, but, at these low oxygen levels, combustion was low or nonexistent, and a near steady-state condition existed. A further indication that supports this supposition is the carbon monoxide levels, as shown in figure 9. With the curtain installed, the CO level increased substantially, with a further increase when the curtain was taped. This increase in CO was the result of incomplete combustion caused by reduced oxygen available to the fire. Thus, the quantity of CO on the protected side of the partition was greatest with the curtain installed. The fourth parameter measured was smoke (light transmission). As seen in figure 10, the smoke level conformed to the same pattern as the temperature. The use of the curtain greatly affected the quantity of smoke in the protected zone, and additional protection was realized with the curtain sealed. Figure 11 shows the curtain installation used in those tests.

SERIES II.

Series II consisted of 11 tests using the same partition and opening as the first series, except that the fire load was reduced from the five pieces of foam, to two (figure 6). In three of the 11 tests, the affects of airflow on the effectiveness of compartmentation was evaluated.

NO AIRFLOW. Of the seven tests conducted with no airflow, a comparison of the data shown in figure 12 through 15 illustrates the salient aspects of this series. The curtain was installed for tests 4, 7, and 9; test 10 had no curtain. Figure 15 shows the eye-level temperature, (A) 3 feet forward of the partition and (B) 3 feet aft of the partition. Although the temperature level was considerably lower using two panels of foam as compared to five panels, the pattern of the temperature profiles was somewhat similar for both fire loads. A significant increase in protection was obtained using a curtain, with a further increase when the curtain was sealed with tape. The test using a partially open curtain provided some thermal protection early in the test, but eventually (about 2 minutes) thermal protection abated to near intolerable levels.

In the aft section, as in the series I tests, when available oxygen to the fire was diminished with a curtain, the thermal rise was slower. The curtain therefore, served to contain the heat and reduce heat production.

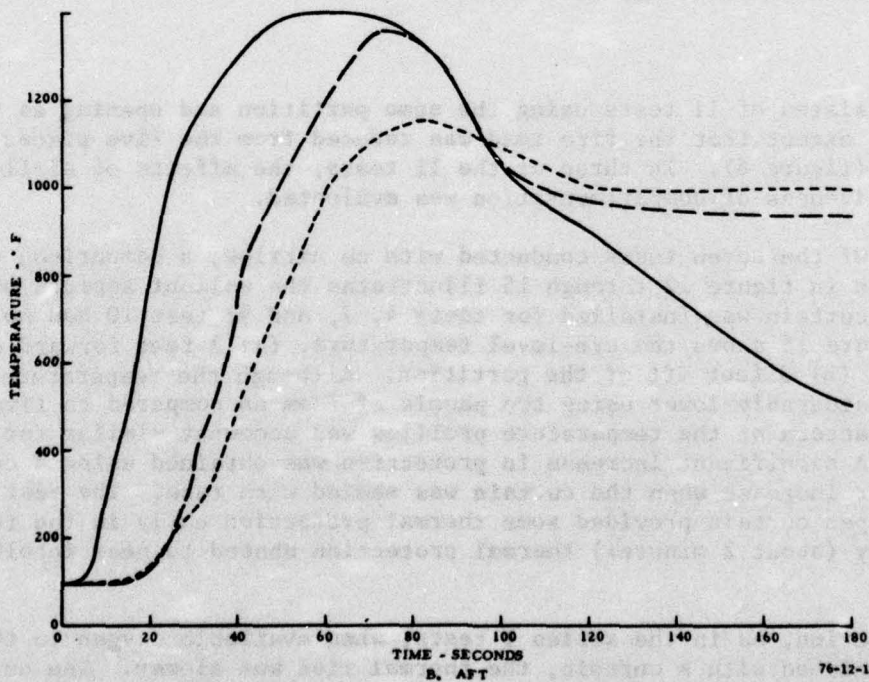
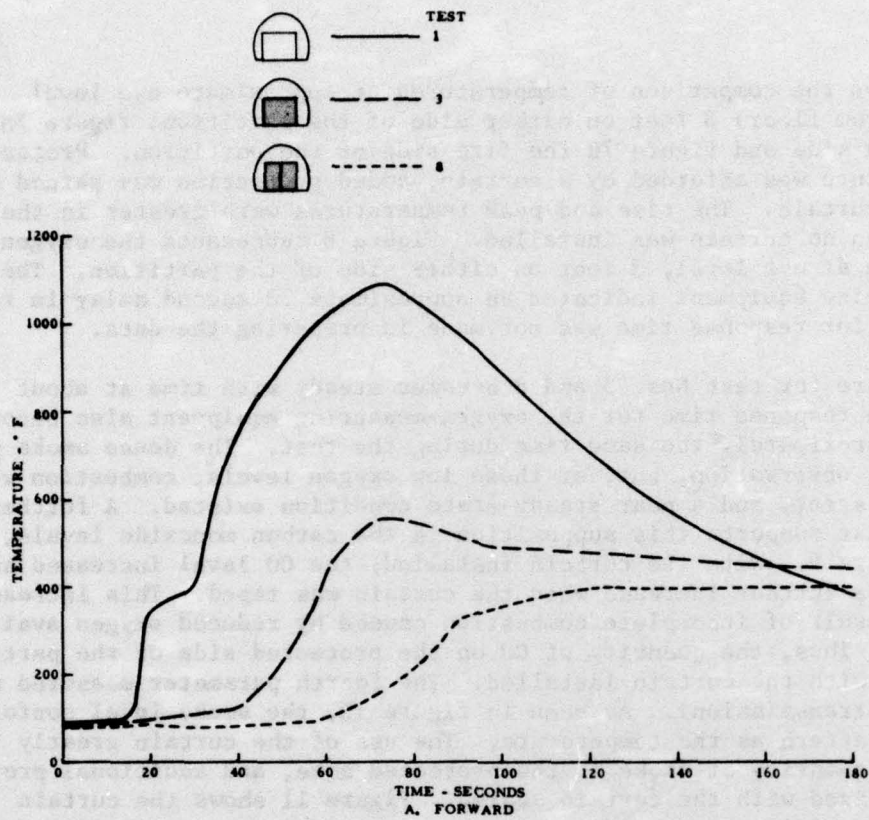

FIGURE 7. LARGE-FIRE TEMPERATURE LEVELS (FIVE FOAM PANELS)

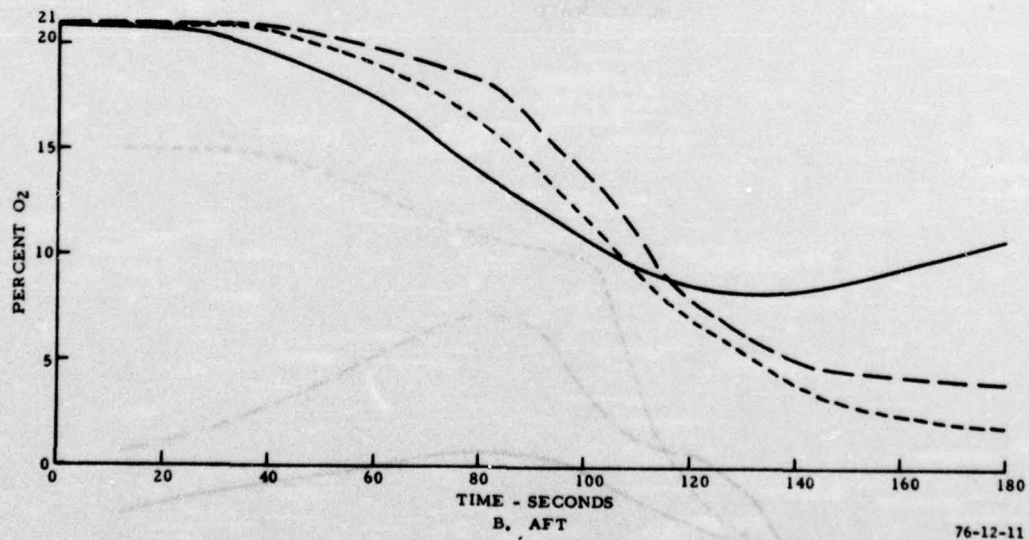
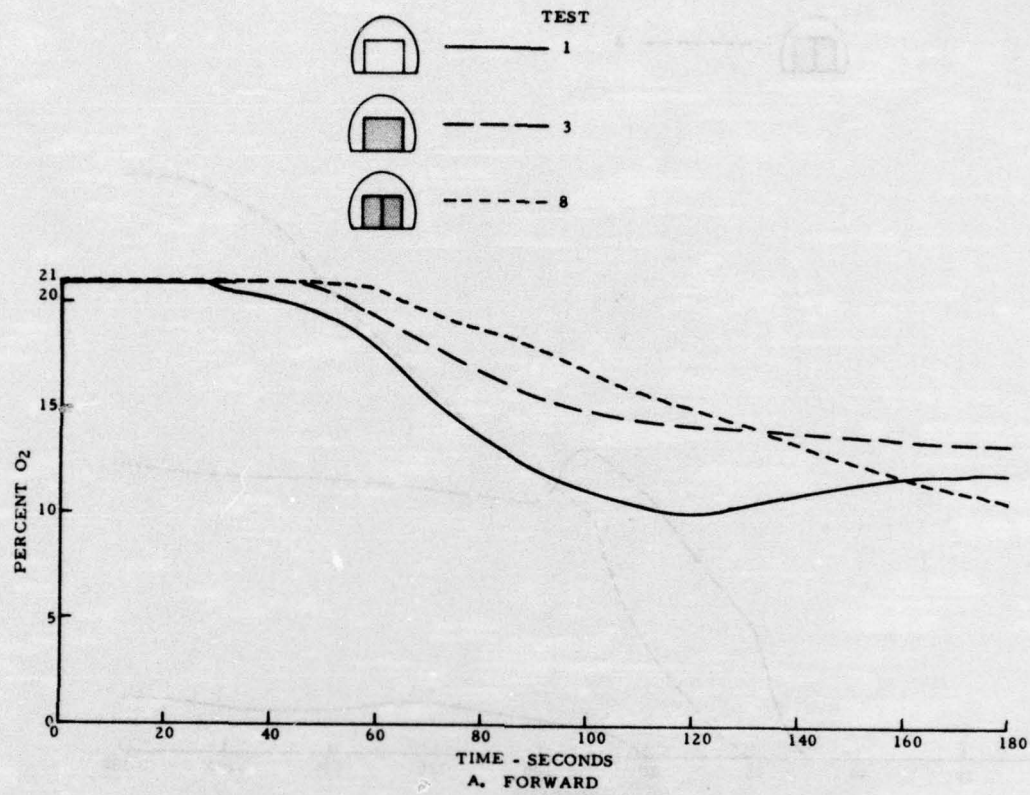

FIGURE 8. LARGE-FIRE OXYGEN LEVELS (FIVE FOAM PANELS)

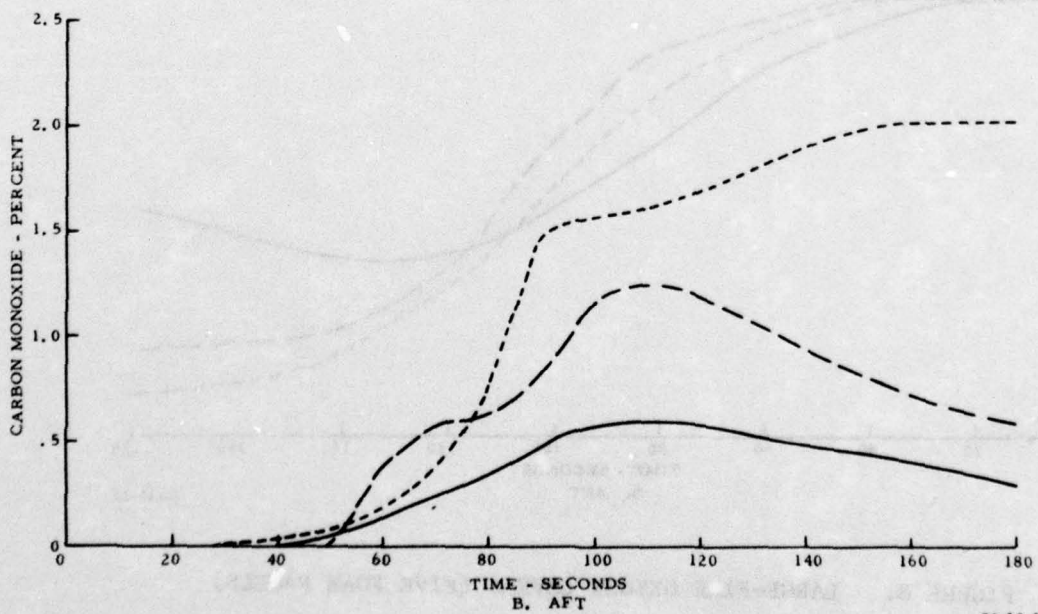
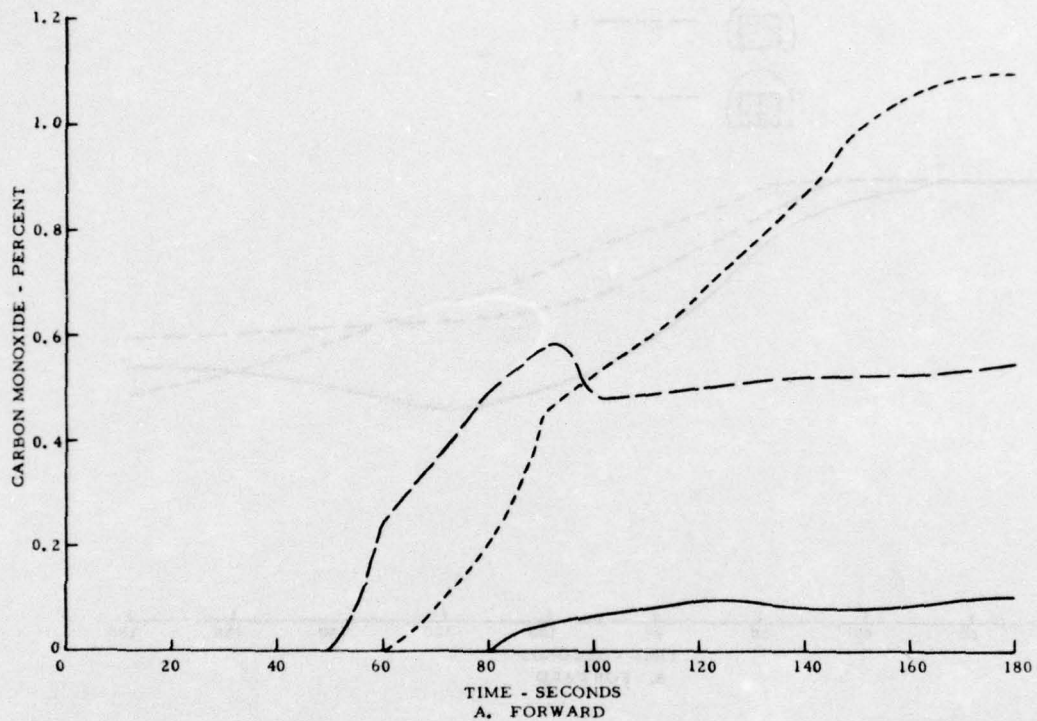
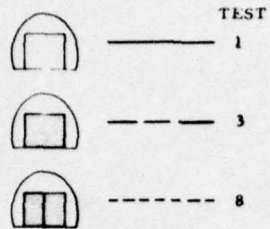
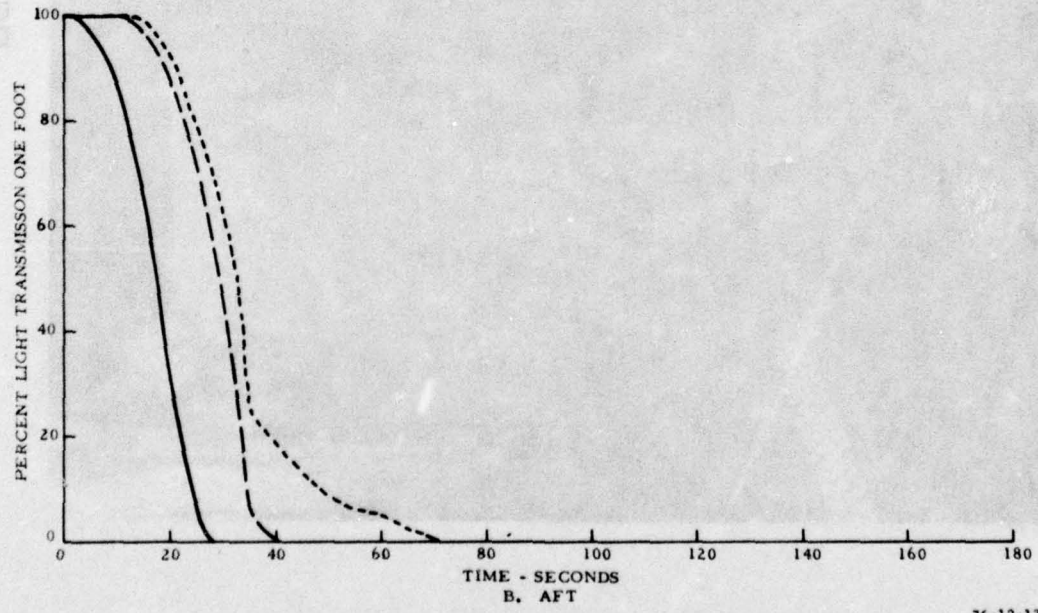
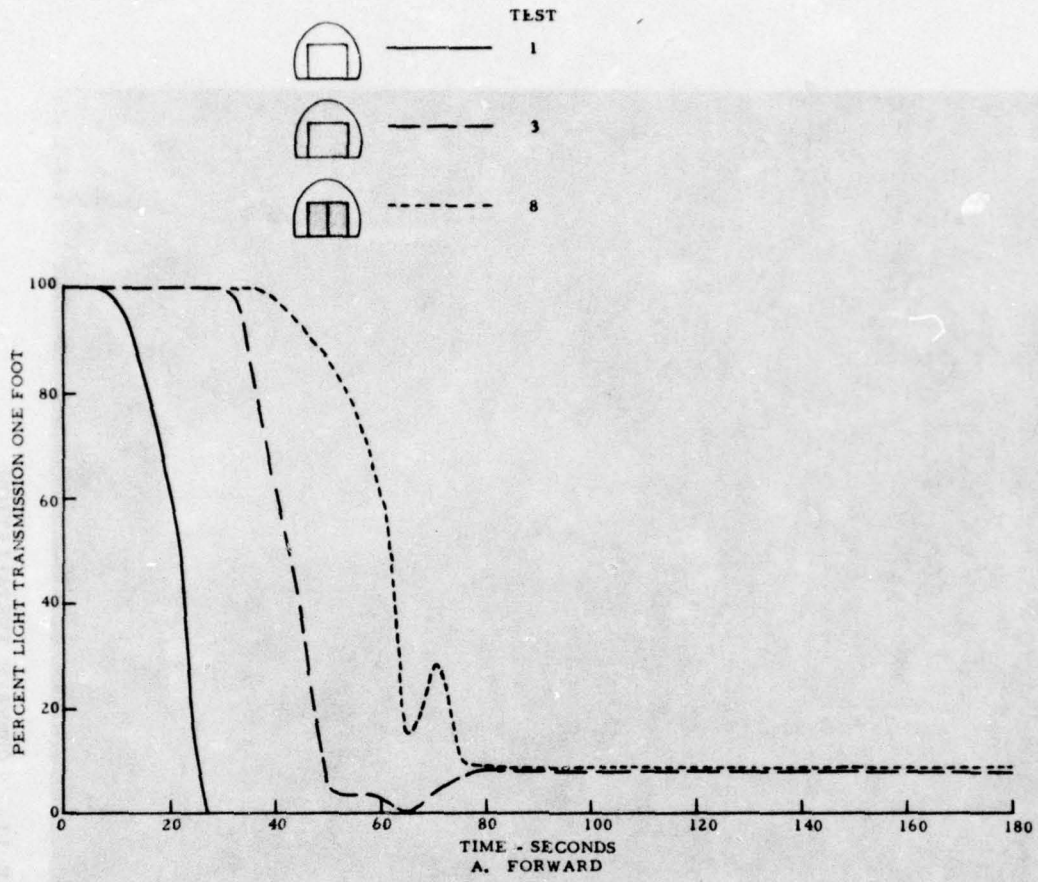

FIGURE 9. LARGE-FIRE CO LEVELS (FIVE FOAM PANELS)

76-12-12



76-12-13

FIGURE 10. LARGE-FIRE SMOKE LEVELS (FIVE FOAM PANELS)



76-12-14

FIGURE 11. CURTAIN INSTALLATION

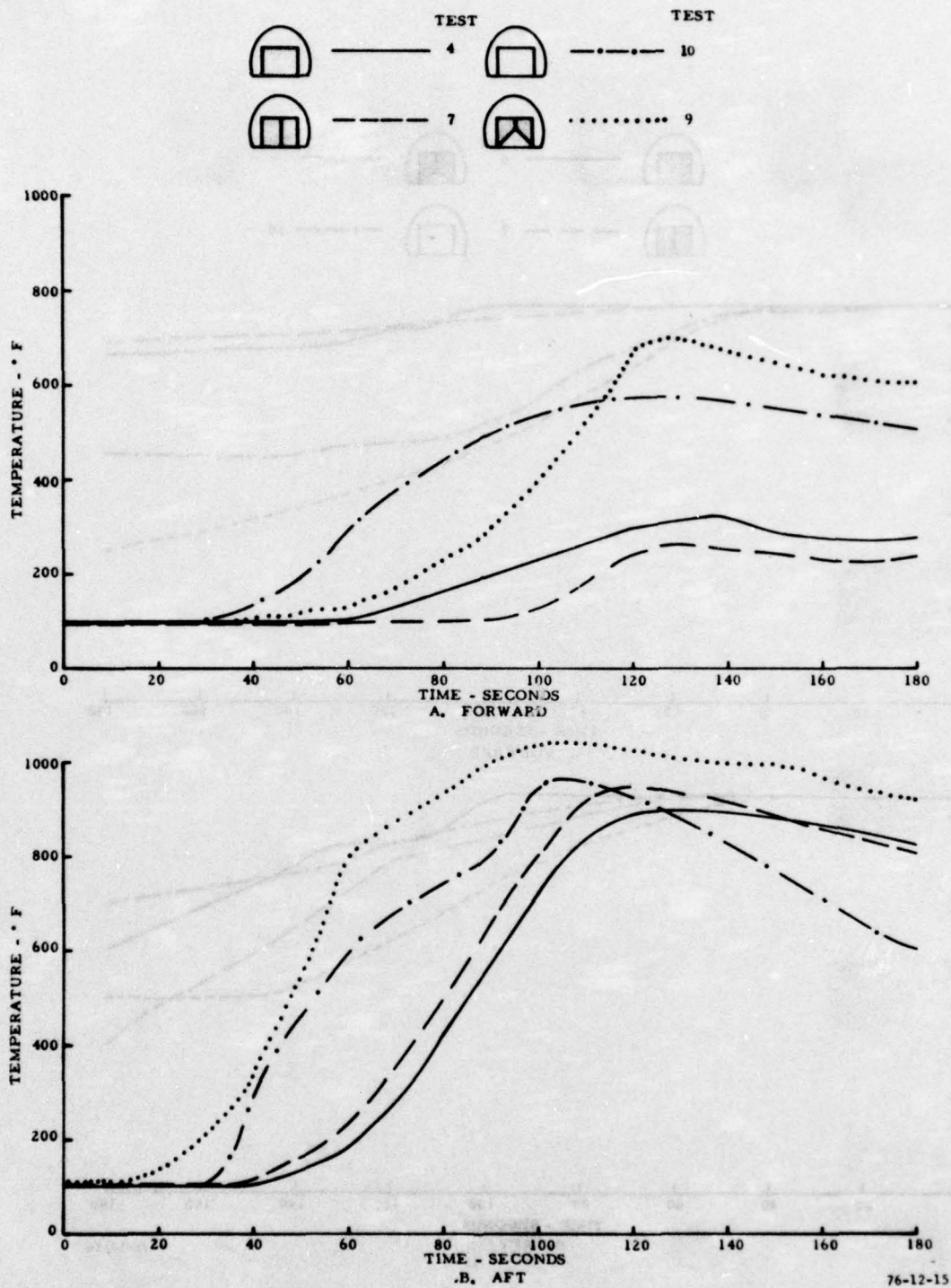

FIGURE 12. TEMPERATURE LEVELS USING TWO FOAM PANELS (NO AIRFLOW)

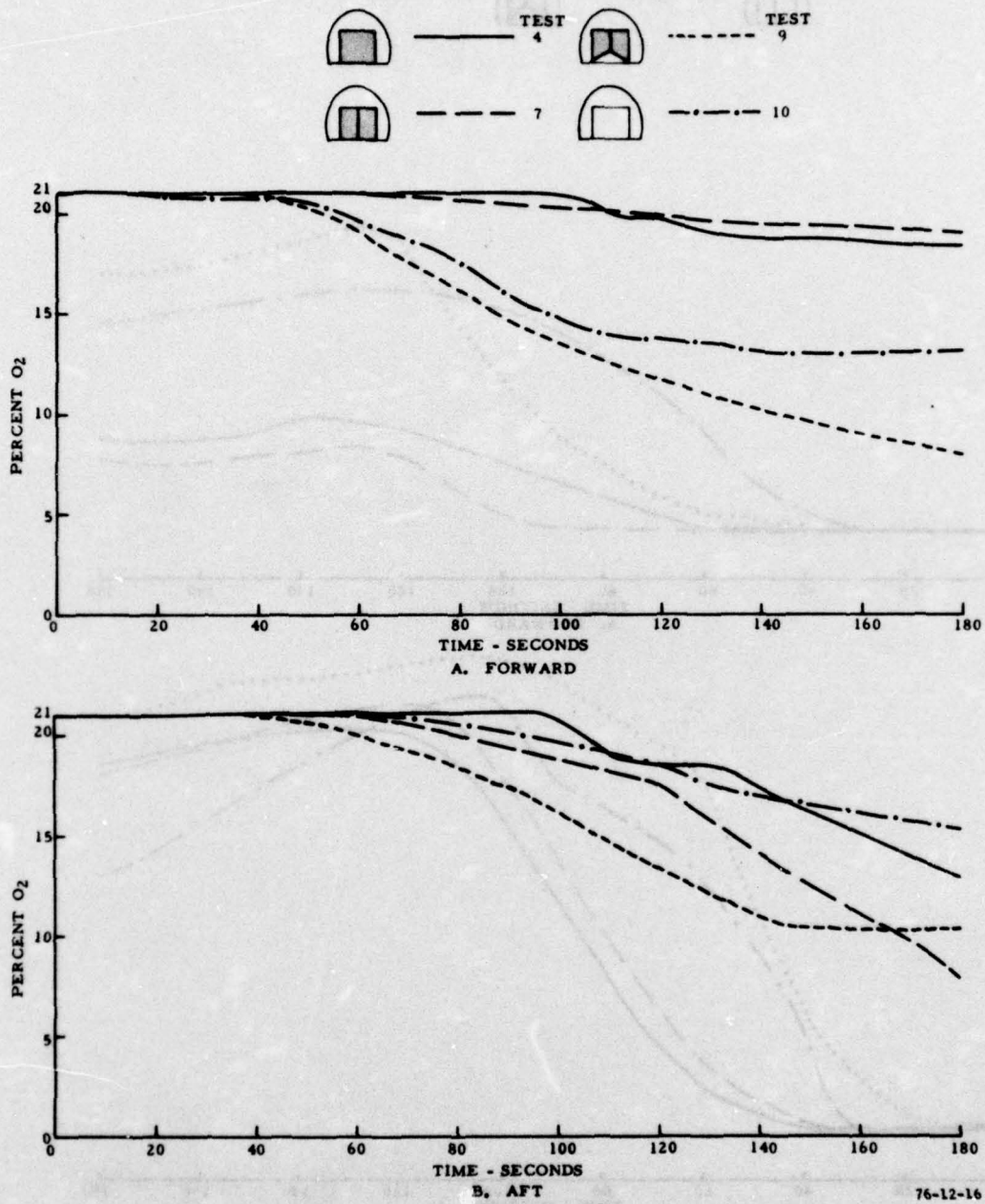

FIGURE 13. OXYGEN LEVELS USING TWO FOAM PANELS (NO AIRFLOW)

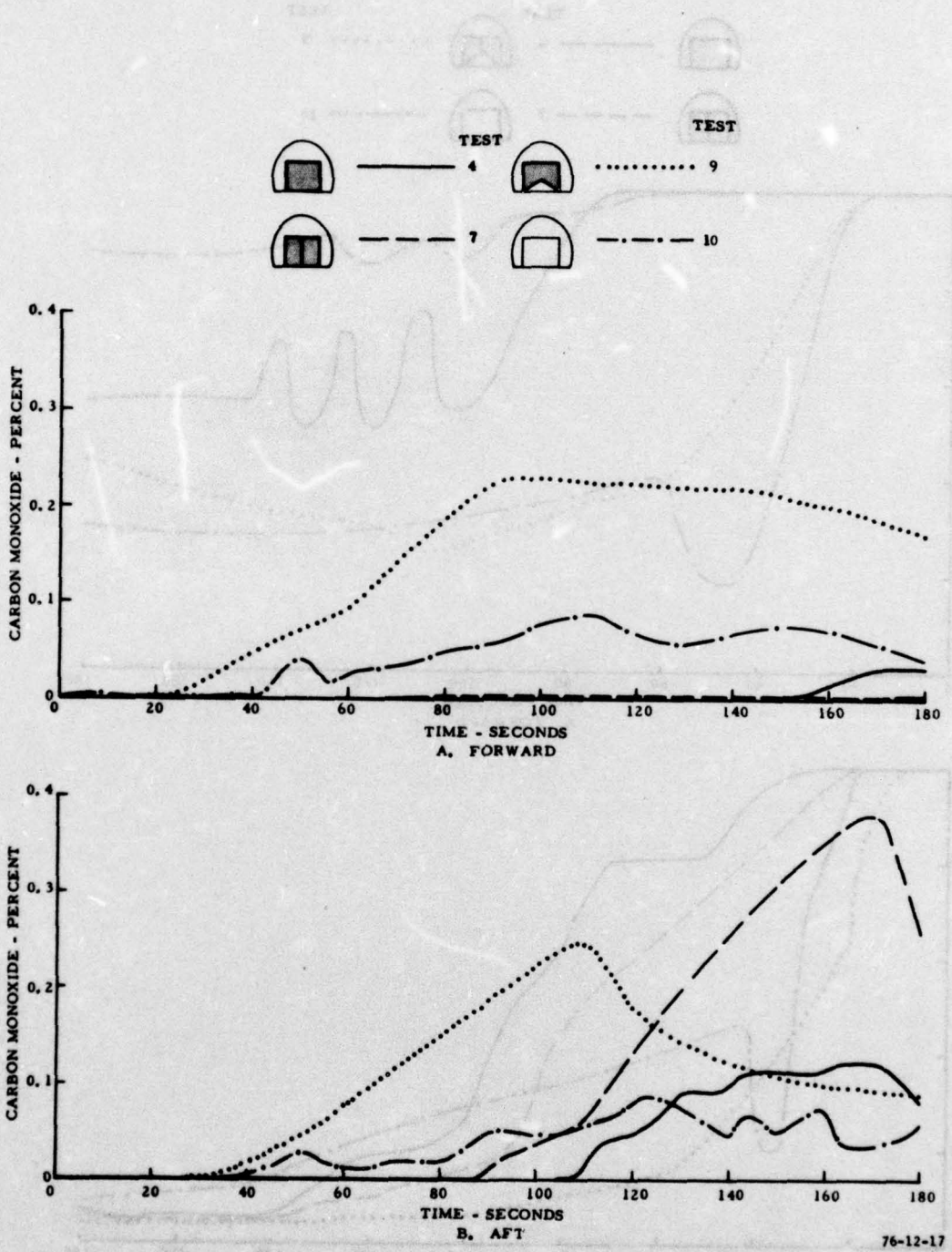

FIGURE 14. CO LEVELS USING TWO FOAM PANELS (NO AIRFLOW)

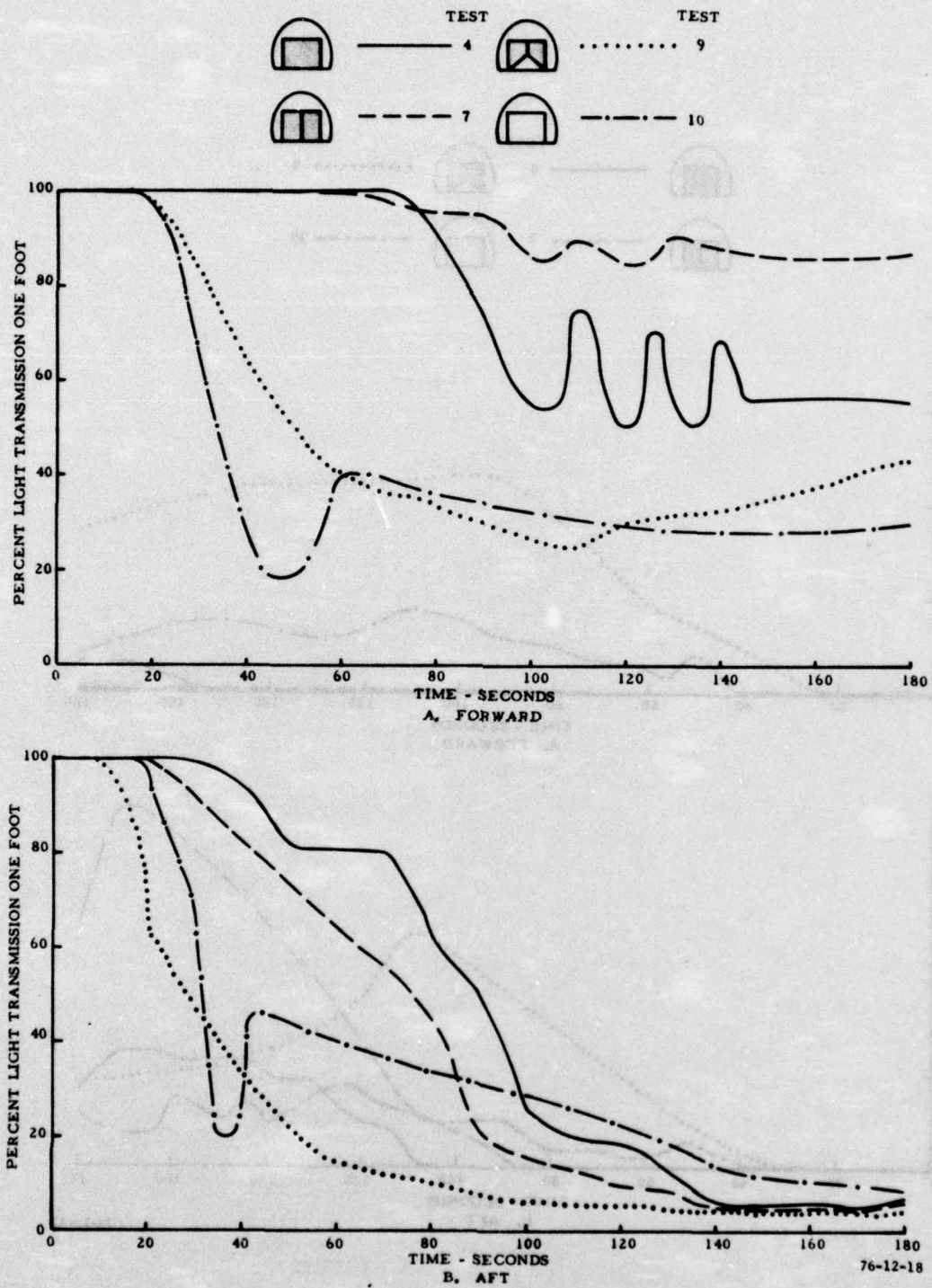

FIGURE 15. SMOKE LEVELS USING TWO FOAM PANELS (NO AIRFLOW)

The oxygen levels followed a similar pattern as in series I, with the concentrations being higher in series II because of the smaller fire load. Again, the oxygen concentration at eye level in the forward section was much lower when no curtain was used. The oxygen concentration (figure 13A) at 2 minutes was 14 percent, as compared to 20 percent with a curtain. The worst case occurred with the curtain installed but left partially open at the bottom. As in series I, the oxygen concentration at eye level on the fire side of the partition was similar to that for the curtain fully open or closed. Oxygen concentration at that point with the curtain partially open was much lower (figure 13B). As in series I, these measured O₂ levels near the partition do not necessarily represent the amount of oxygen available to the fire.

The aft CO concentrations show a similar pattern as in series I. The highest concentrations occurred when the curtain was installed. The highest aft concentration (figure 14B) was recorded with the curtain closed and sealed, but the more rapid rise occurred when the curtain was partially open at the bottom. Unlike series I, the fully closed taped curtain prevented the spread of CO to the protected area (figure 14A). It is assumed that this difference in results is related to the fire intensity, the smaller fire causing less circulation of air, and less pressure buildup in the fire section; therefore, less flow from one compartment to the other. The least protection from CO occurred with the curtain open at the bottom, with CO levels of 0.23 percent in 90 seconds, as compared to 0.05 percent with no curtain, and no CO recorded when the curtain was fully closed.

Again, as in series I, the effects of the curtain on fire intensity is seen by observing smoke levels in both the protected and fire areas (figure 15A and B). Light transmission (visibility) is less in the fire zone without a curtain, than when the curtain was fully closed. Very little protection is afforded by the partially closed curtain.

The data from tests were similar to data from tests 10 and 4.

2,800 ft³/min - AIRFLOW. Three tests were conducted in series II using a forced airflow of 2,800 ft³/min. This, when calculated, equates to an air velocity of 40 feet per minute in the fire zone.

The plot of temperature at eye level (figure 16) shows that the thermal protection provided by the curtain is reduced under this condition. Sealing the curtain provides some short-term protection, but did not approach the level as when no airflow was present. An open door 2 feet by 6 feet could produce the same airflow with a steady 2.7-mi/h breeze.

The curtain provided limited protection against smoke (figure 17), but unlike tests with no airflow and a sealed curtain, slightly more smoke entered the protected area. This was due to the fact that much more smoke was generated when the curtain was taped. Forced ventilation affects fire dynamics, altering the effect the curtain configuration has on the burn rate and products of combustion. Very little drop in oxygen occurred during these airflow tests, and little or no CO was recorded.

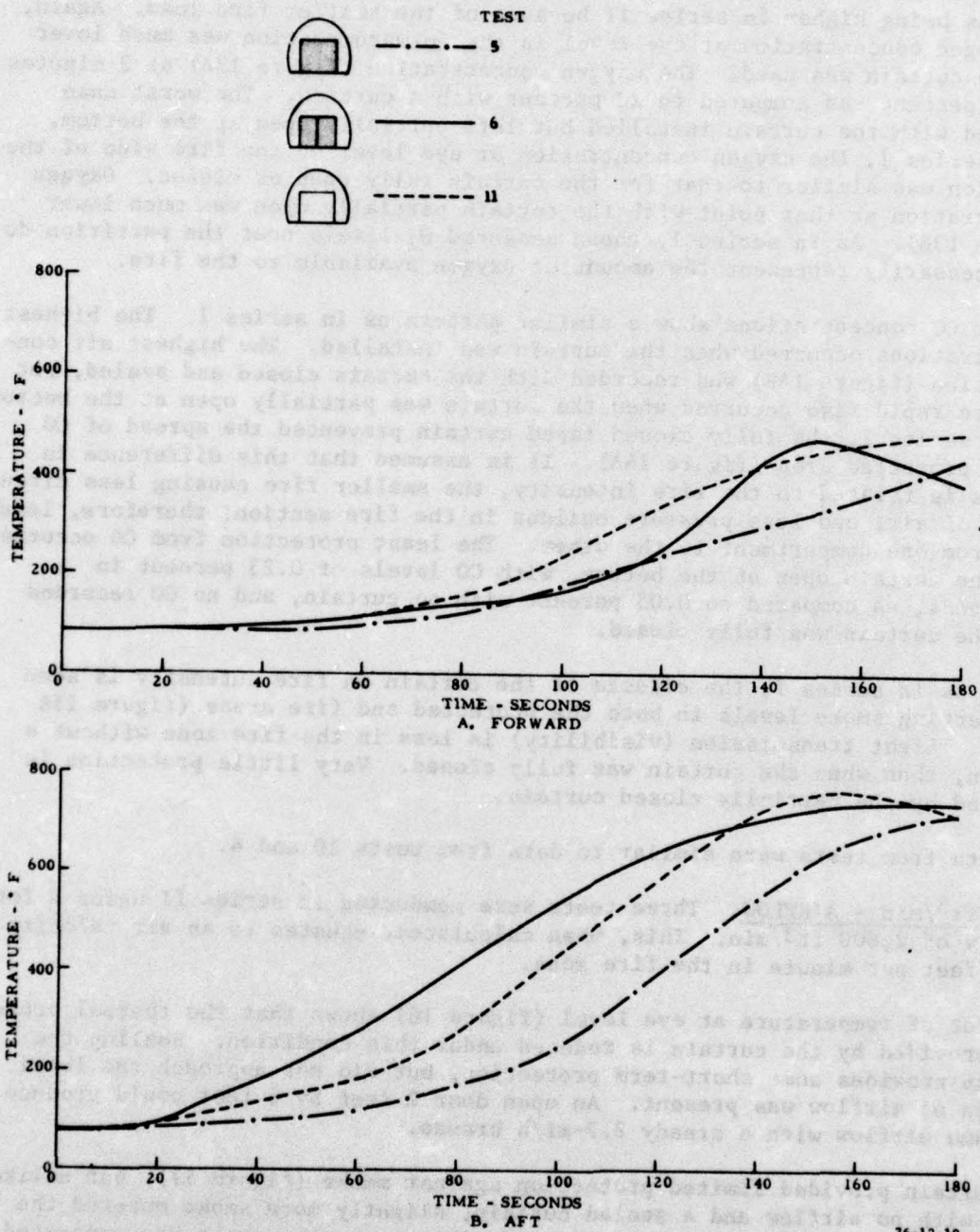

FIGURE 16. TEMPERATURE LEVELS USING TWO FOAM PANELS (2,800 ft³/min AIRFLOW)

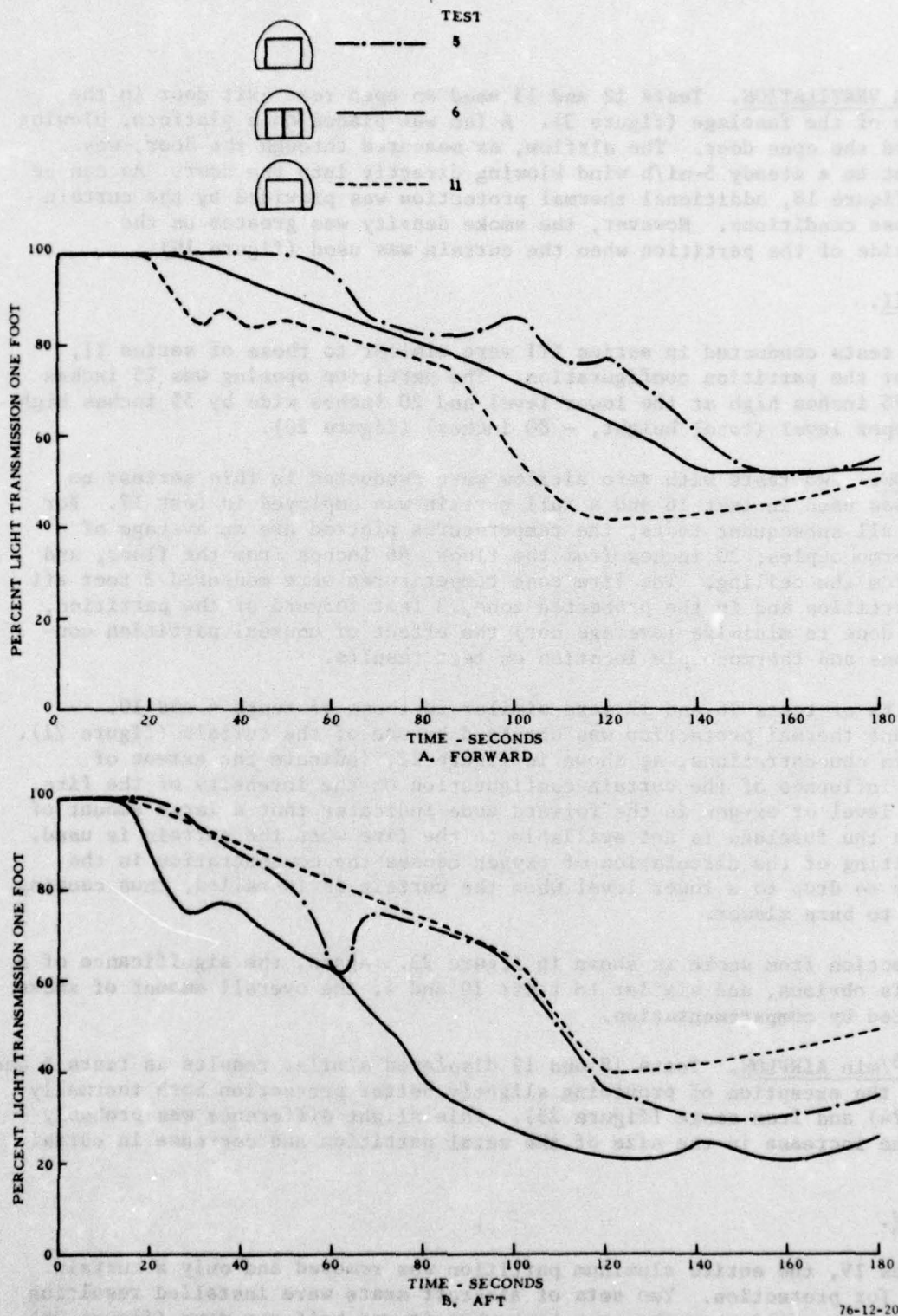

FIGURE 17. SMOKE LEVELS USING TWO FOAM PANELS (2,800 ft³/min AIRFLOW)

OPEN-DOOR VENTILATION. Tests 12 and 13 used an open rear exit door in the fire zone of the fuselage (figure 3). A fan was placed on a platform, blowing air toward the open door. The airflow, as measured through the door, was equivalent to a steady 5-mi/h wind blowing directly into the door. As can be seen in figure 18, additional thermal protection was provided by the curtain under those conditions. However, the smoke density was greater on the forward side of the partition when the curtain was used (figure 19).

SERIES III.

The four tests conducted in series III were similar to those of series II, except for the partition configuration. The partition opening was 15 inches wide by 25 inches high at the lower level and 20 inches wide by 55 inches high at the upper level (total height, - 80 inches) (figure 20).

NO AIRFLOW. Two tests with zero airflow were conducted in this series: no curtain was used in test 16 and a full curtain was employed in test 17. For this and all subsequent tests, the temperatures plotted are an average of three thermocouples; 20 inches from the floor, 66 inches from the floor, and 1 inch from the ceiling. The fire zone temperatures were measured 3 feet aft of the partition and in the protected zone, 3 feet forward of the partition. This was done to minimize (average out) the effect of unusual partition configurations and thermocouple location on test results.

The results of tests 16 and 17 were similar to those of tests 4 and 10. Significant thermal protection was obtained by use of the curtain (figure 21). The oxygen concentrations, as shown in figure 22, indicate the extent of possible influence of the curtain configuration on the intensity of the fire. The high level of oxygen in the forward zone indicates that a large amount of oxygen in the fuselage is not available to the fire when the curtain is used. This limiting of the circulation of oxygen causes the concentration in the fire zone to drop to a lower level when the curtain is installed, thus causing the fire to burn slower.

The protection from smoke is shown in figure 23. Again, the significance of a curtain is obvious, and similar to tests 10 and 4, the overall amount of smoke was reduced by compartmentation.

2,800 ft³/min AIRFLOW. Tests 18 and 19 displayed similar results as tests 5 and 11, with the exception of providing slightly better protection both thermally (figure 24) and from smoke (figure 25). This slight difference was probably due to the increase in the size of the metal partition and decrease in curtain area.

SERIES IV.

For series IV, the entire aluminum partition was removed and only a curtain was used for protection. Two sets of aircraft seats were installed resulting in the curtain resting on the seat back when it was half-way down (figure 26).

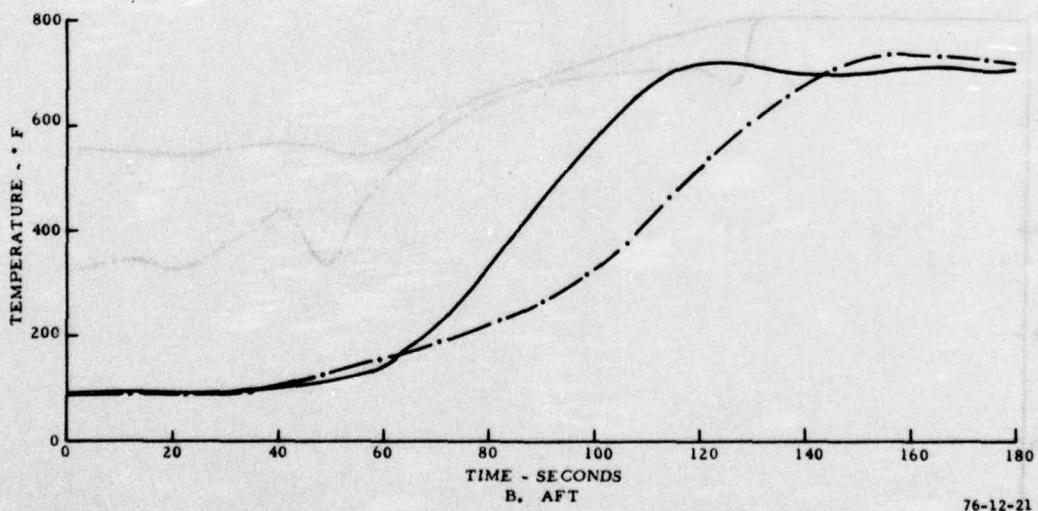
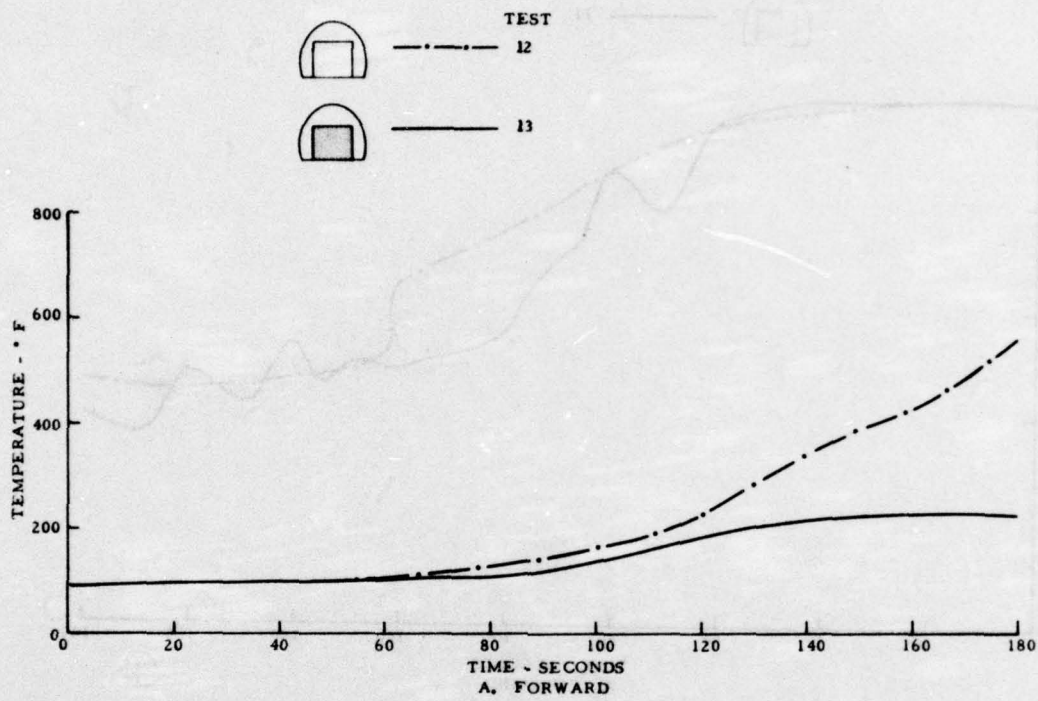

76-12-21

FIGURE 18. TEMPERATURE LEVELS (AIRFLOW THROUGH DOOR EXIT)

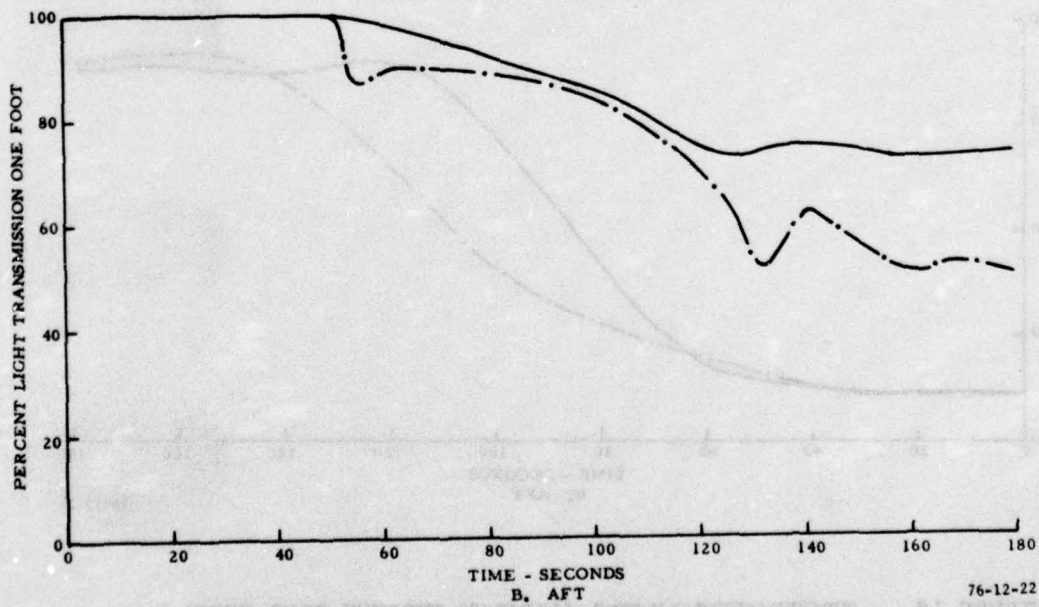
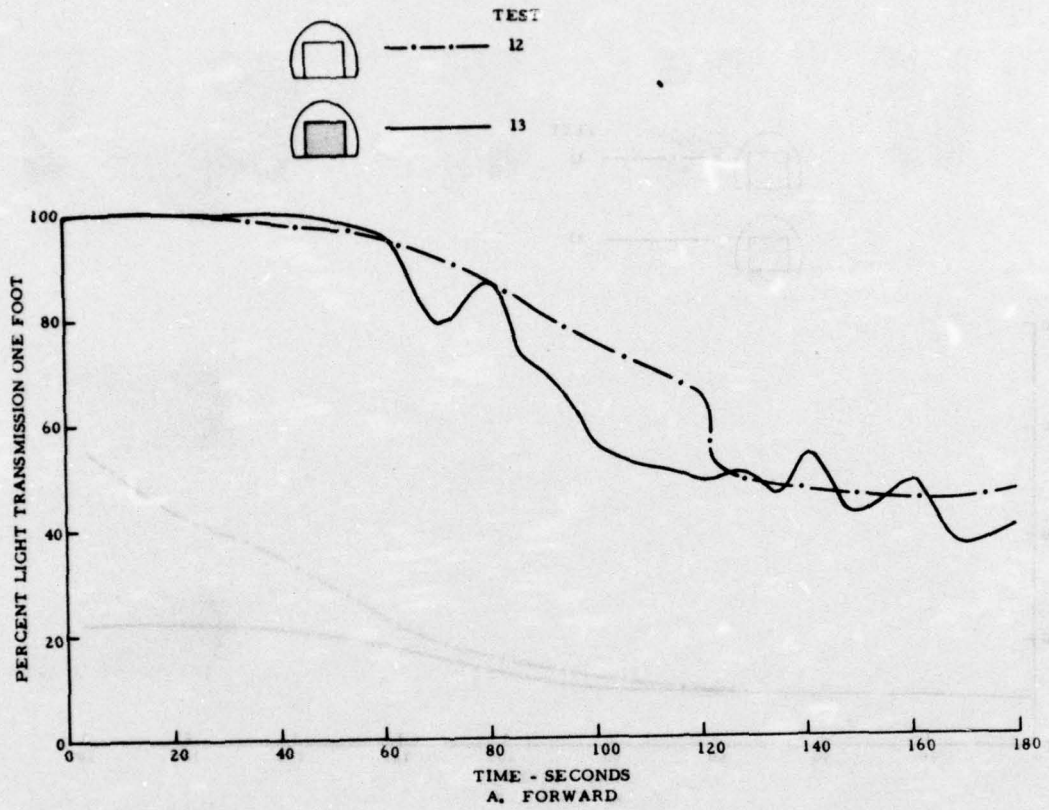

FIGURE 19. SMOKE LEVELS (AIRFLOW THROUGH DOOR EXIT)

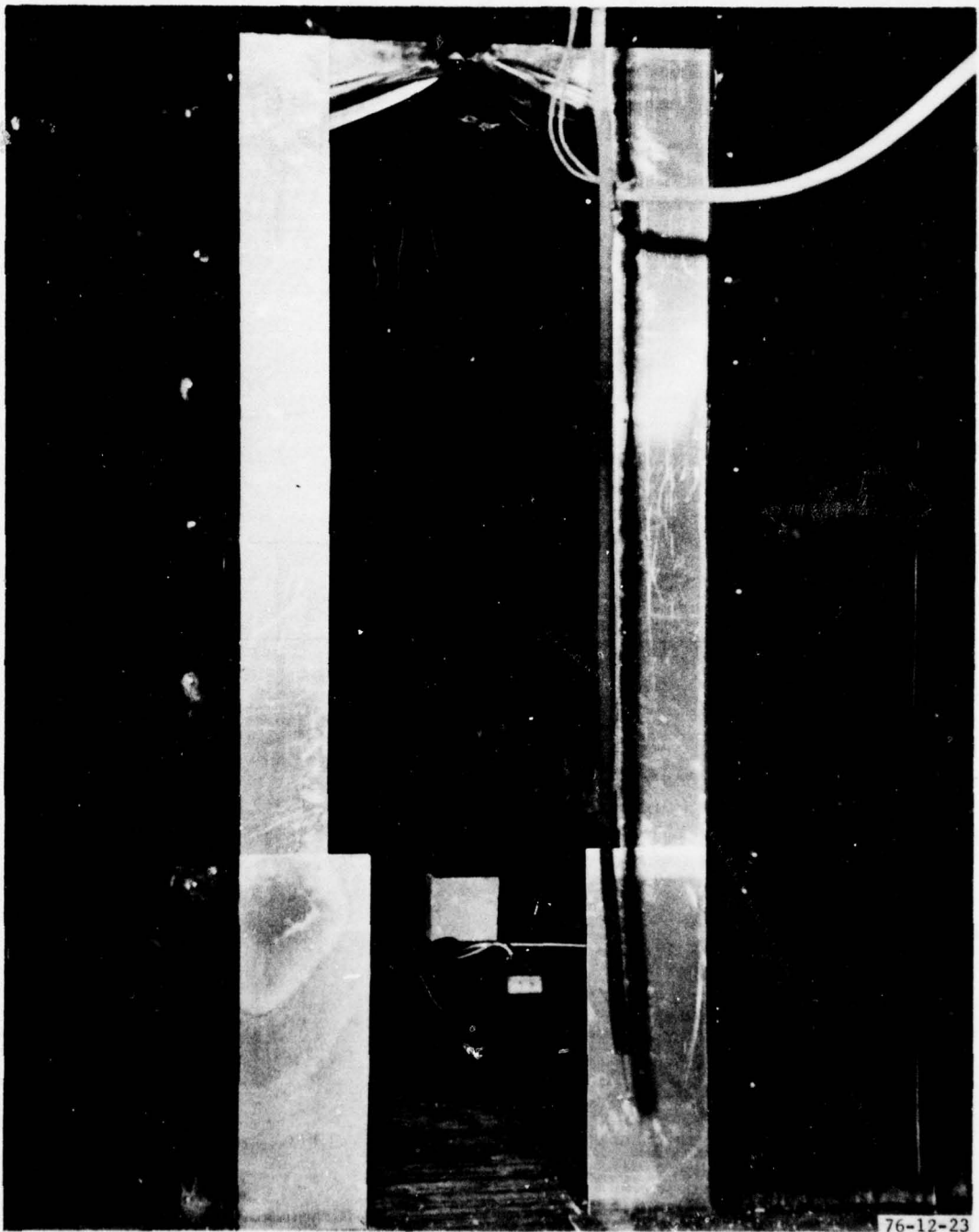

FIGURE 20. MINIMUM AISLE WIDTH PER FEDERAL AVIATION
REGULATION (FAR 25.815)

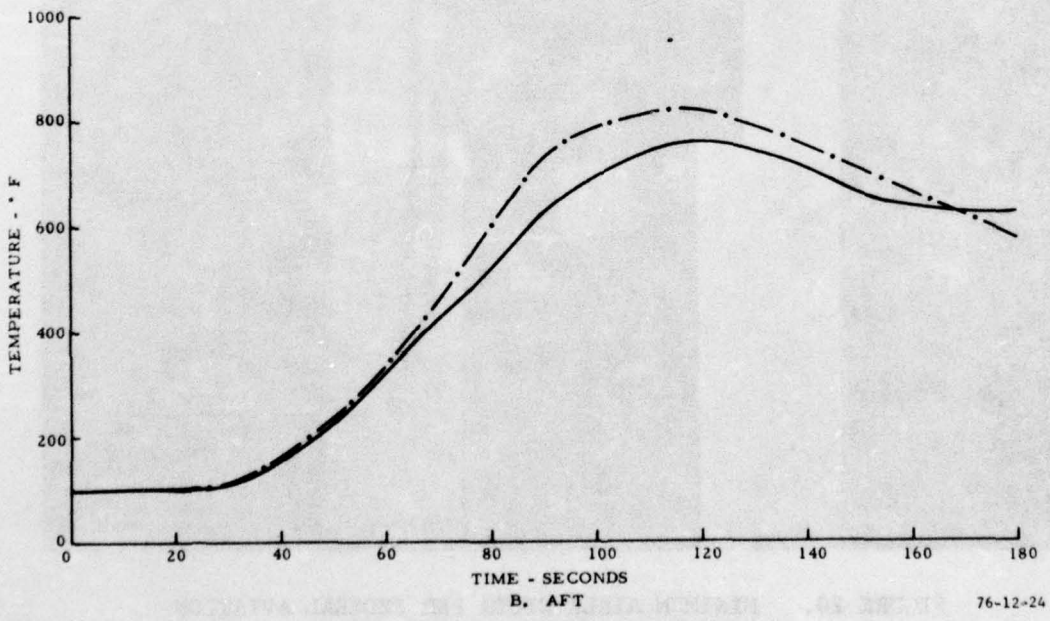
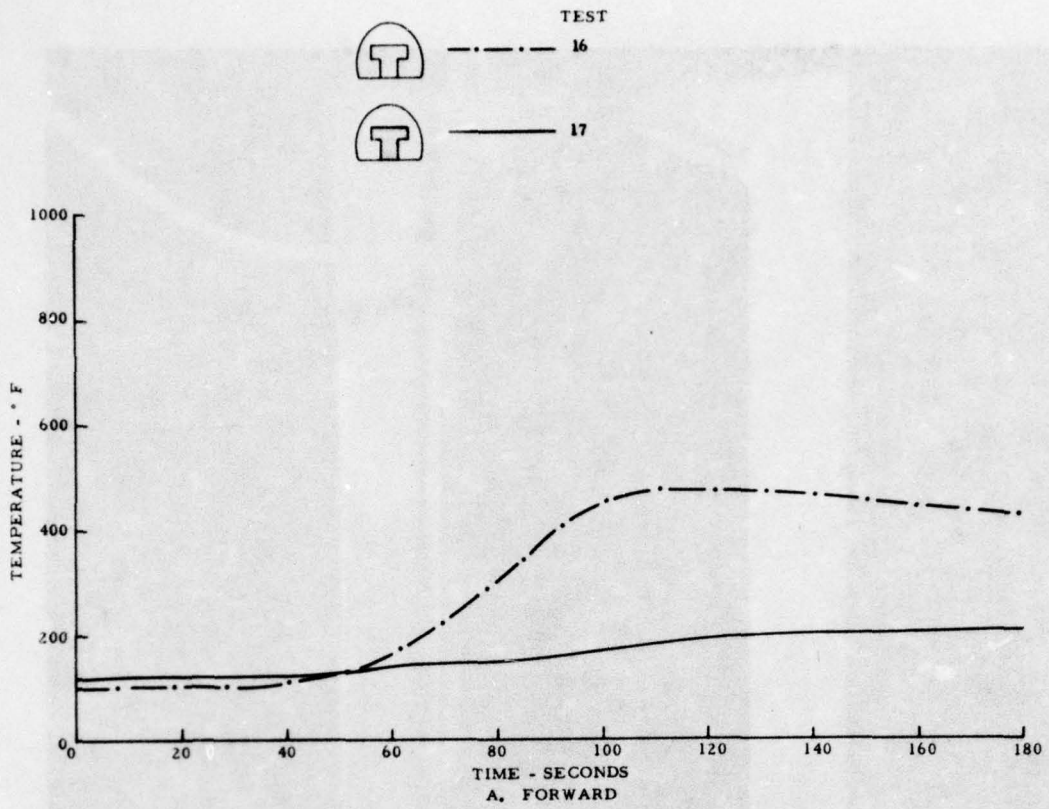

FIGURE 21. TEMPERATURE LEVELS USING FAR PARTITION (NO AIRFLOW)

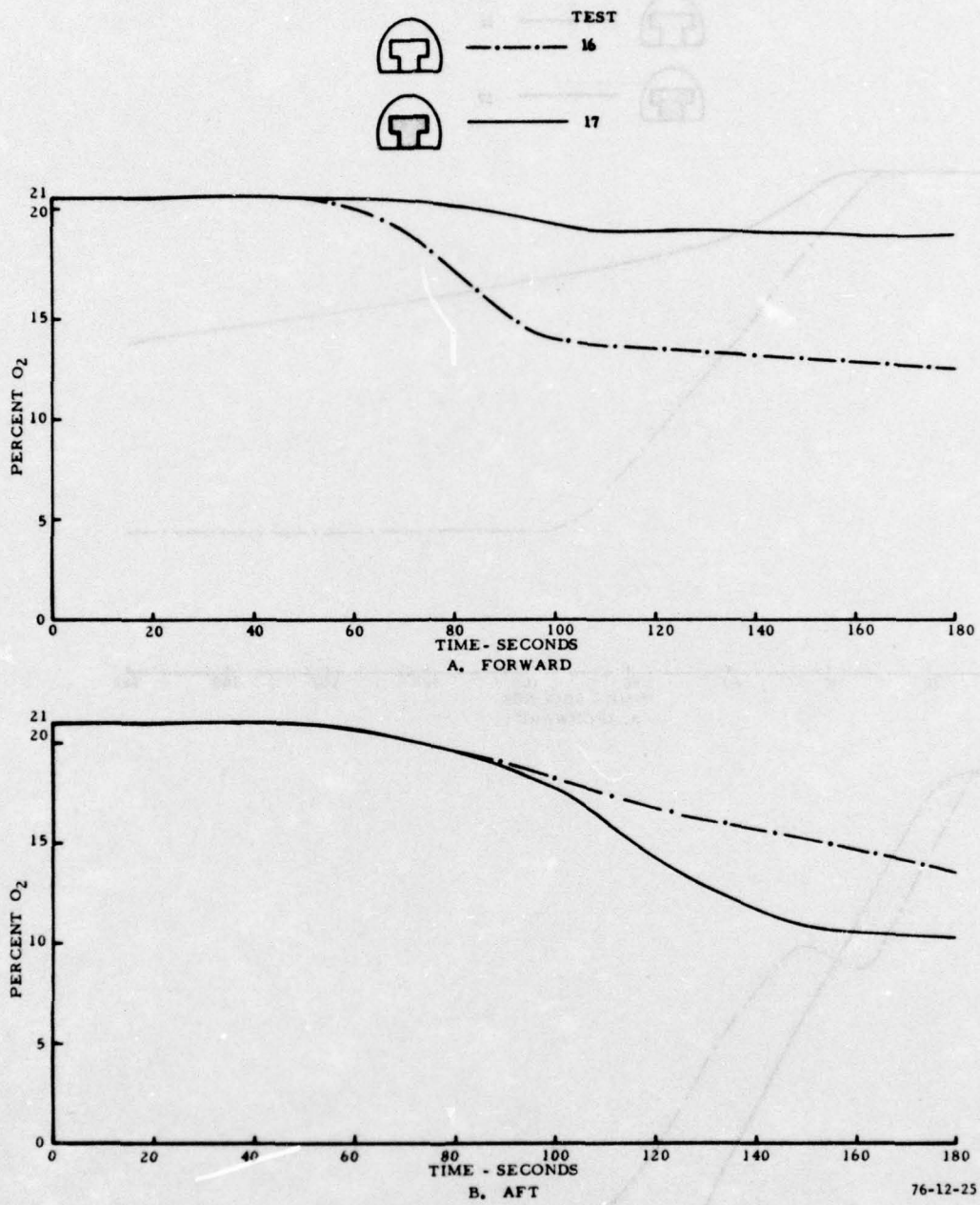

FIGURE 22. OXYGEN LEVELS USING FAR PARTITION (NO AIRFLOW)

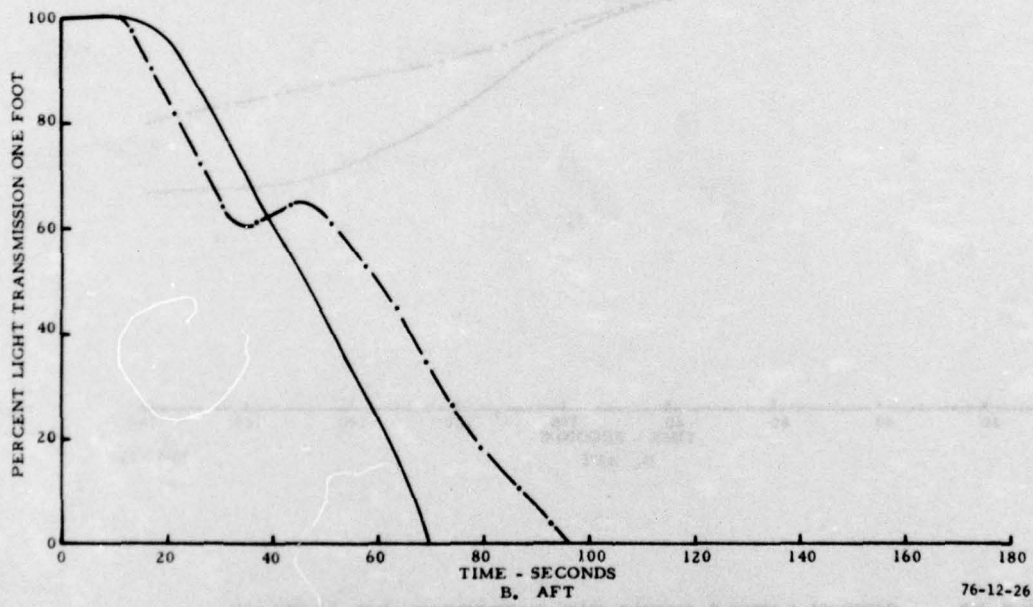
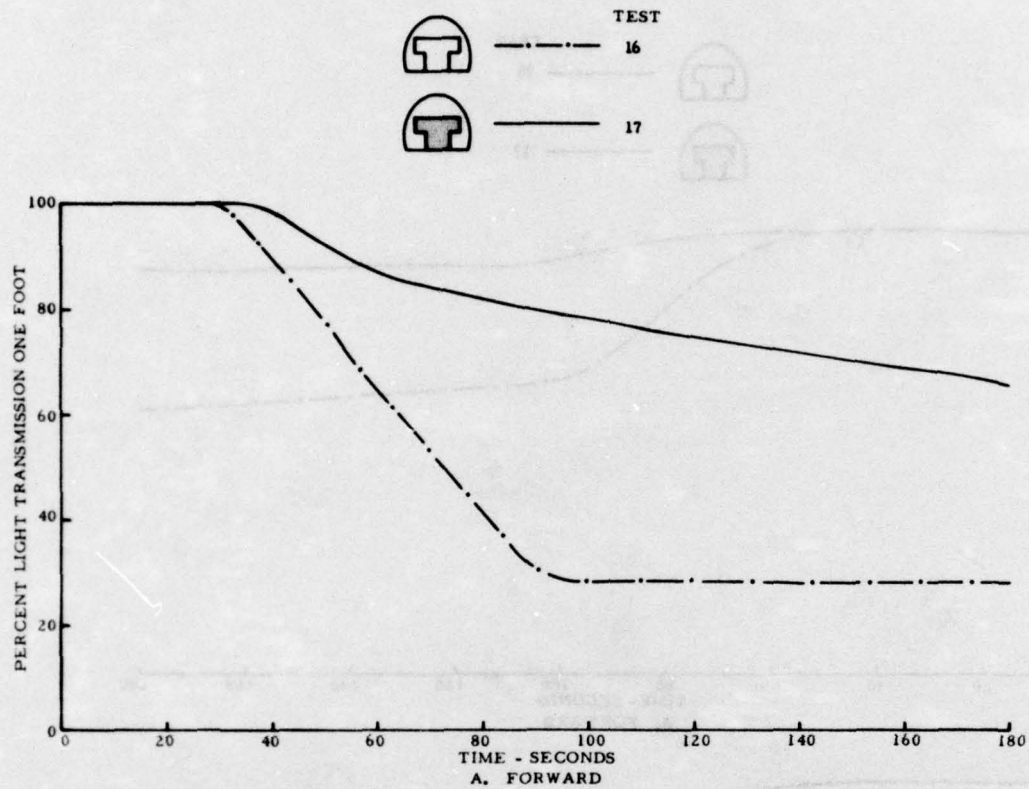
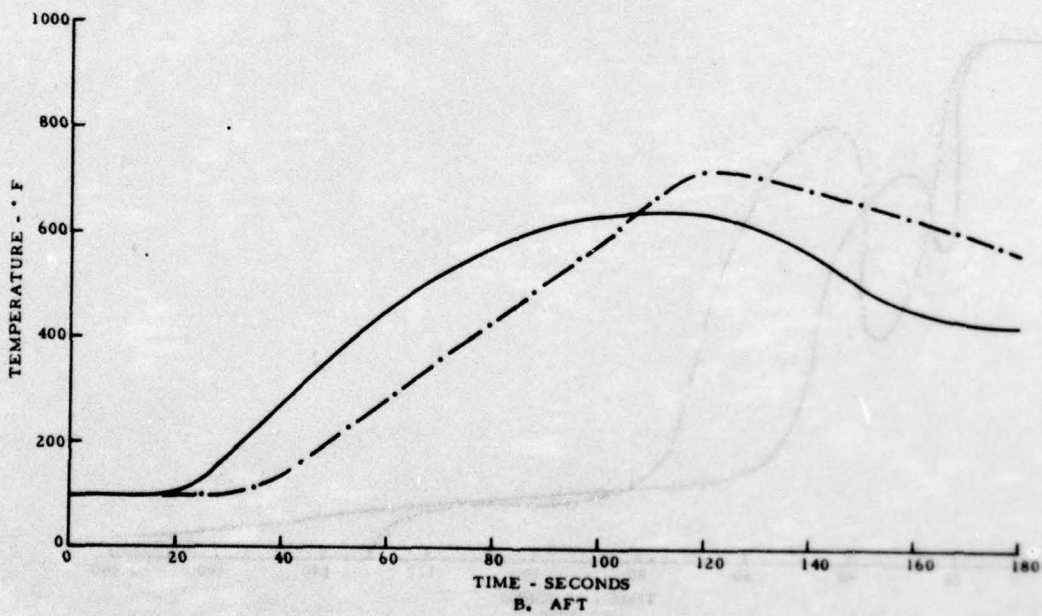
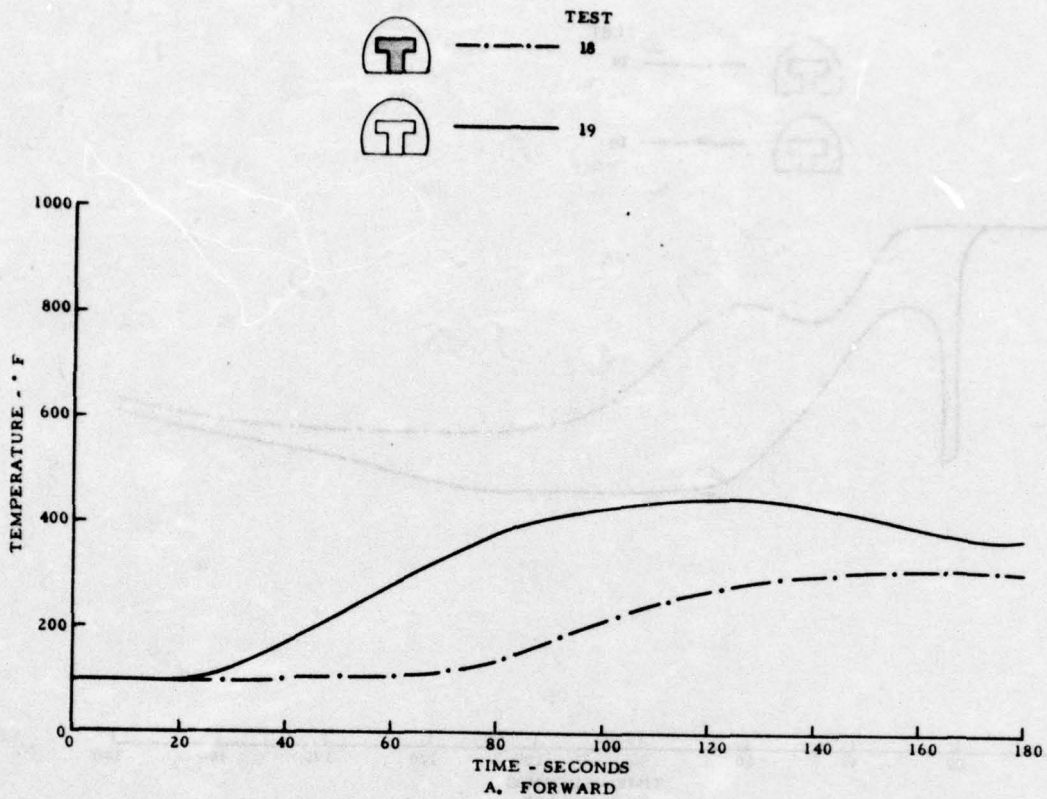
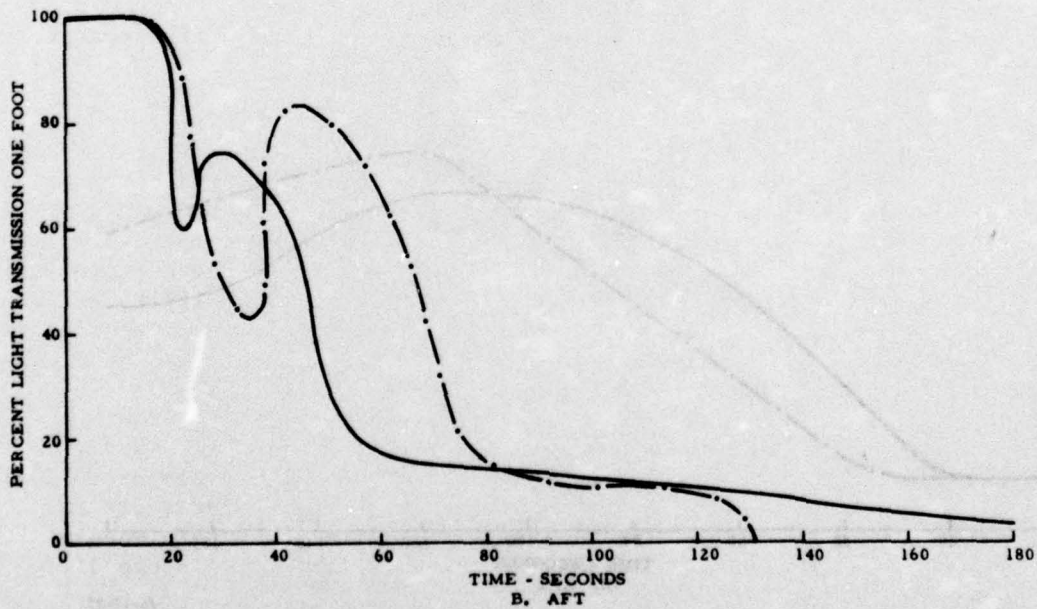
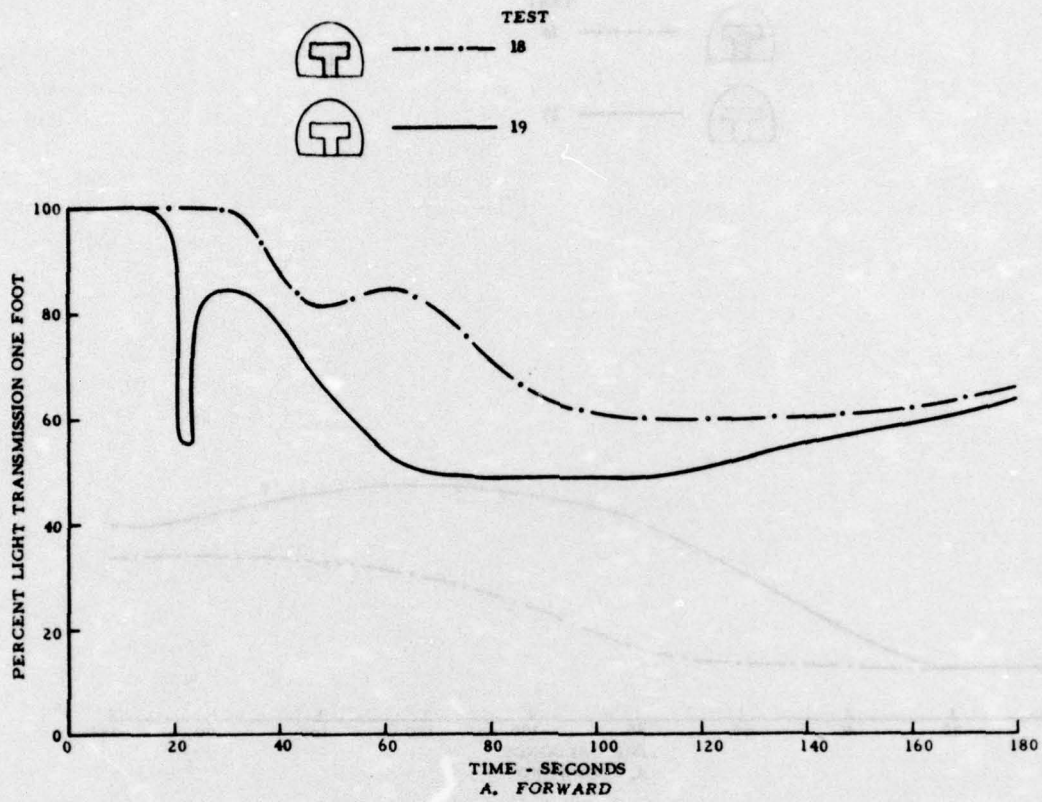

FIGURE 23. SMOKE LEVELS USING FAR PARTITION (NO AIRFLOW)



76-12-27

FIGURE 24. TEMPERATURE LEVELS USING FAR PARTITION (2,800 ft³/min AIRFLOW)



76-12-28

FIGURE 25. SMOKE LEVELS USING FAR PARTITION (2,800 ft³/min AIRFLOW)

NO AIRFLOW. Three tests were conducted in this series with no forced airflow. Test 20 used no curtain, while in test 22, the curtain was down to the seat back, (figure 26) and in test 24, the curtain was down to floor level. The results of these tests (figure 27) showed that significant thermal protection could be obtained when a curtain was lowered only to the top of the seat backs. The partition configuration in these three tests were similar to that of tests 4, 9, and 10. The results of tests with the curtain open and the curtain fully closed were very similar, the major difference occurring with the partially closed curtain. Various reasons could account for this difference, with the probable cause being a combination of the difference in configuration with the curtain half open during each test, and the difference in the temperature locations during the two series (i.e., series I graphs are eye-level temperatures, and series IV are an average temperature).

The smoke density pattern follows that of the temperature, in that protection is provided with the use of a curtain. As seen in figure 28, the protection for the first 80 seconds with the curtain down to the seat back or extended to the floor was comparable. After 80 seconds, there was greater protection from the full curtain.

Figures 29 and 30 provide a brief overview of the protection afforded by three types of partition configurations. At 90 seconds, there was a 100° F difference in temperature between the forward and aft zones when no curtain was used, as compared to 360° F when a curtain was deployed to the seat backs, and 560° F when the curtain was fully deployed. The smoke displayed similar trends. At 90 seconds and no curtain, the difference in percent light transmission between the forward and aft section was slight, while a difference of 56 percent was exhibited with the curtain half-way down. A difference of 64 percent was recorded with the curtain fully deployed.

2,800 ft³/min AIRFLOW. As previously discussed in tests with airflow, the amount of protection provided by a curtain was reduced, as compared to that provided when there is no forced ventilation. Figure 31 shows that some protection can be obtained when the curtain is dropped to the seat backs. The level of protection was greatest, i.e., the lowest recorded temperature levels, with the curtain deployed to the seat backs. However, with the curtain fully extended to the floor, the greatest fore and aft temperature difference occurred. The aspect that has remained constant throughout the tests described is that the greatest temperature difference between fire and nonfire zones occurs with the curtain fully extended to the floor, with lesser difference occurring with the curtain to the seat backs, or with no curtain. Therefore, disregarding the effects a curtain configuration may have on fire dynamics, the greatest degree of protection, i.e., largest fore and aft temperature difference, occurs with the opening fully closed. Comparing figures 31A and 31B, the difference between forward and aft zones with no curtain was 40° F; with the curtain to the seat backs and to the floor, the temperature differences were 260° F, and 420° F, respectively.

Figure 32 is an average of three thermocouples in the far forward section of the fuselage (thermocouples Nos. 1, 2, and 3). Although no direct comparison

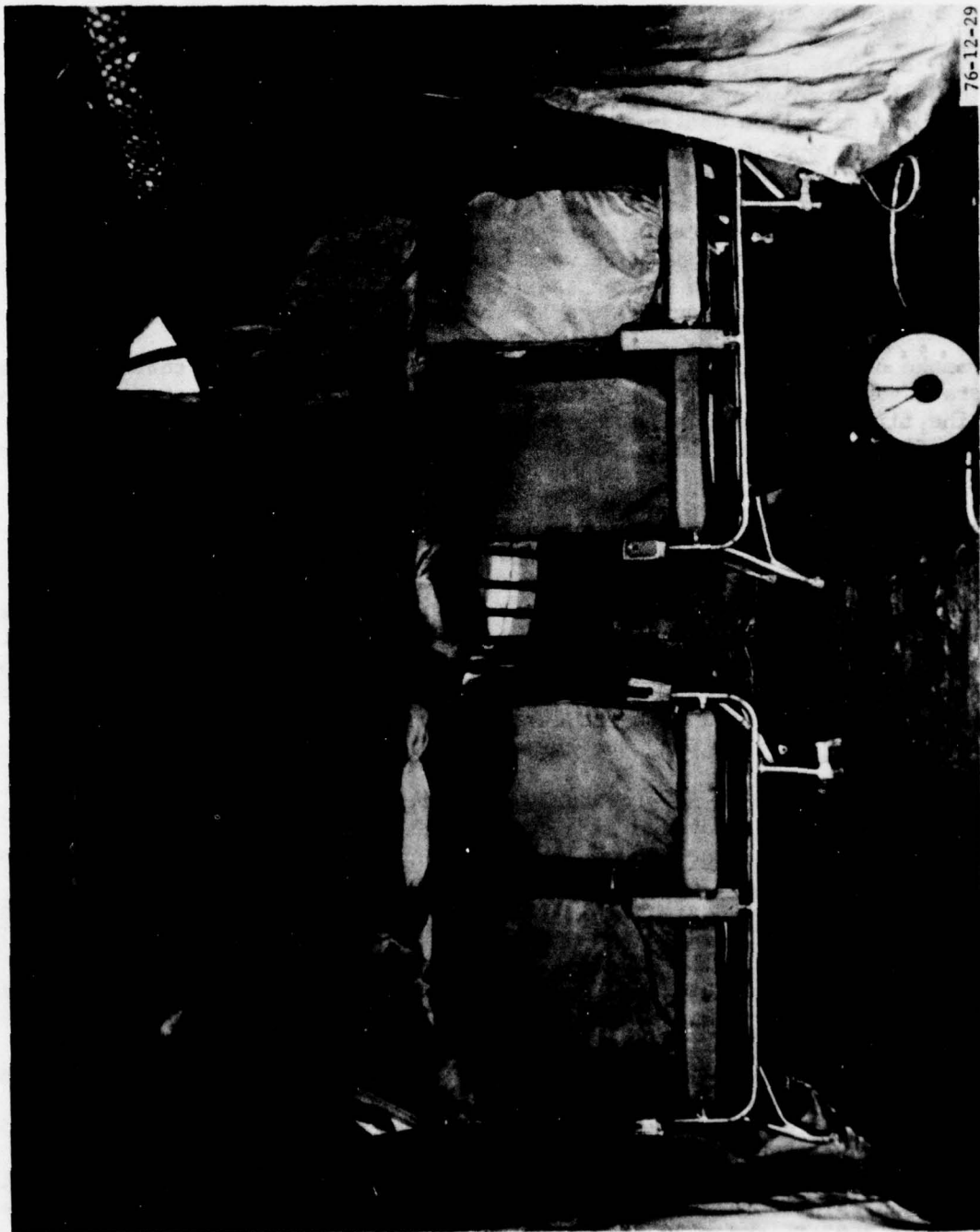

76-12-29

FIGURE 26. CURTAIN HALFWAY DOWN

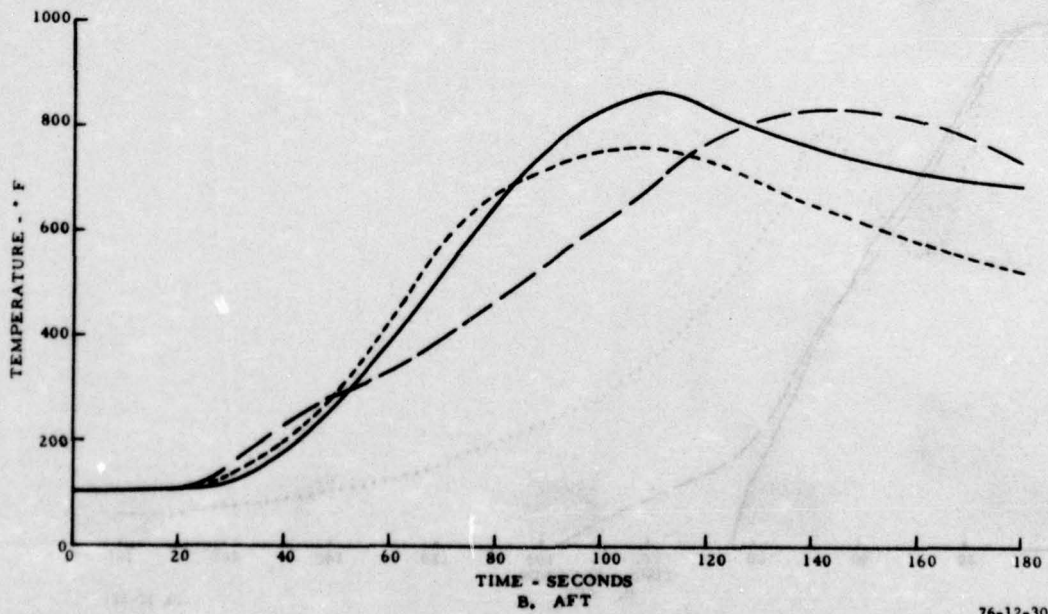
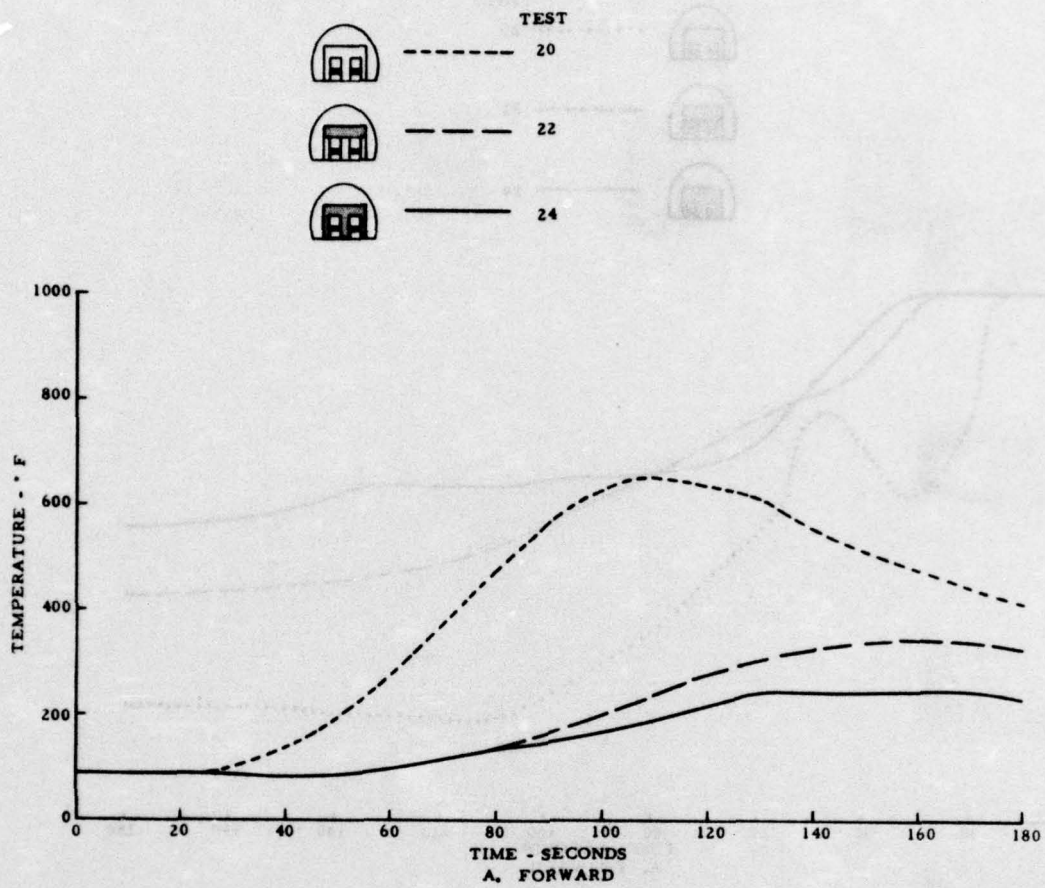

76-12-30

FIGURE 27. TEMPERATURE LEVELS WITH SEATS INSTALLED AT PARTITION

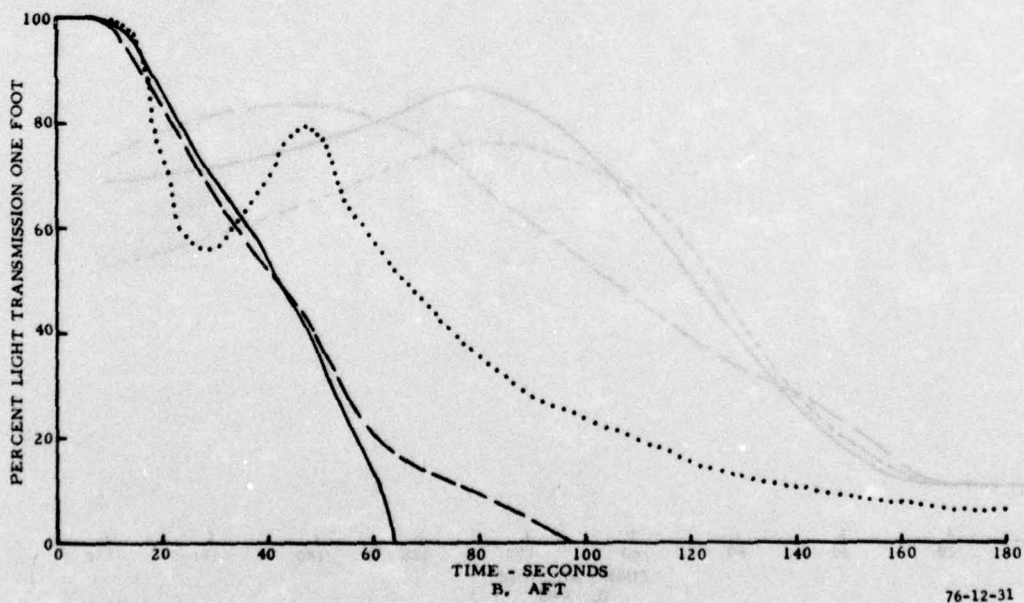
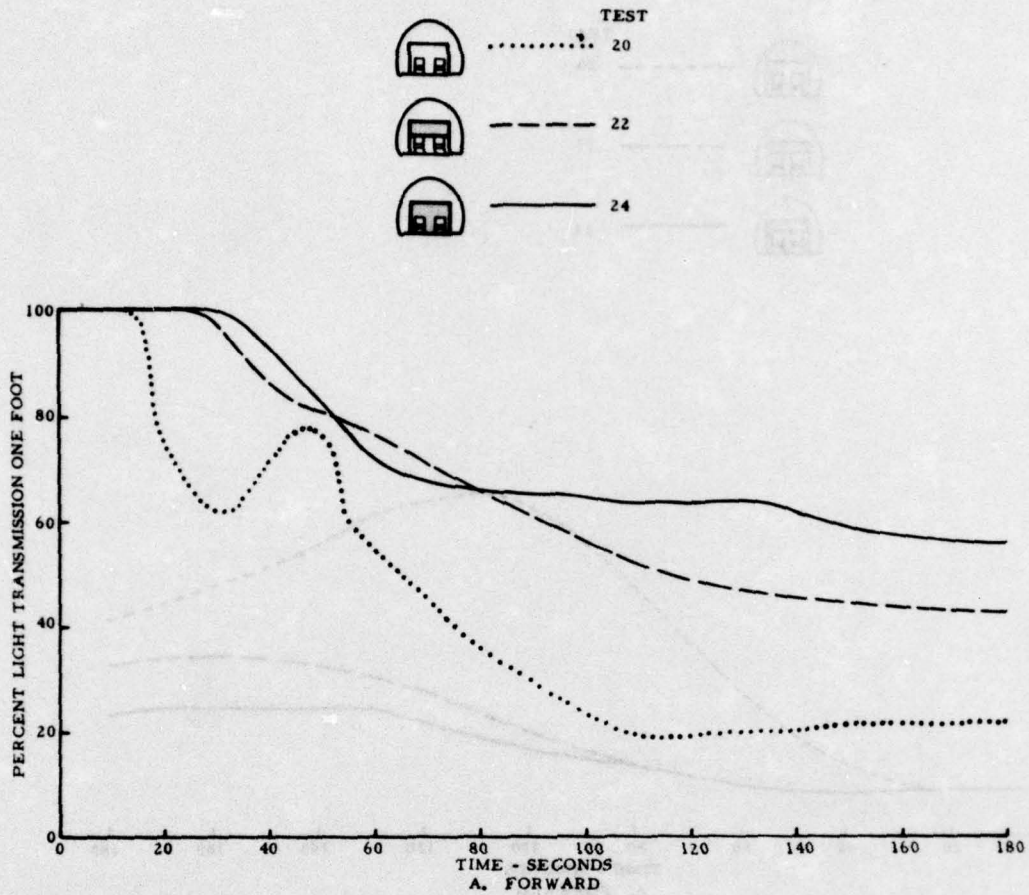

FIGURE 28. SMOKE LEVELS WITH SEATS INSTALLED AT PARTITION

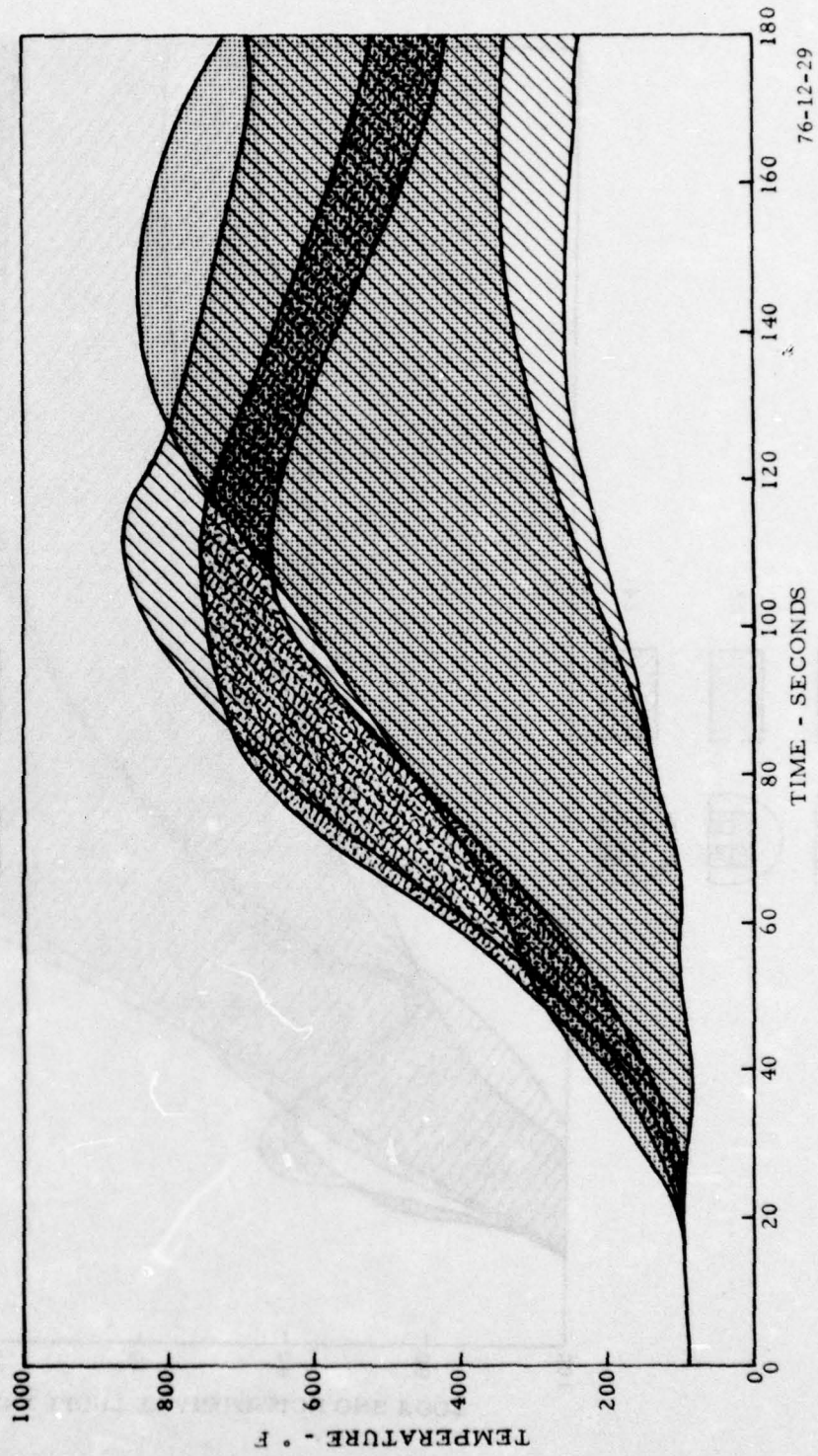
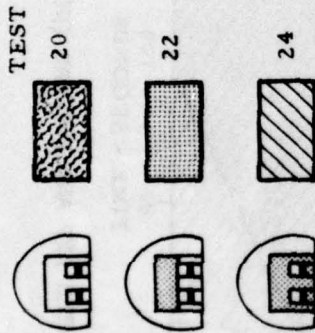

FIGURE 29. TEMPERATURE RANGE BETWEEN AFT AND FORWARD (NO AIRFLOW)

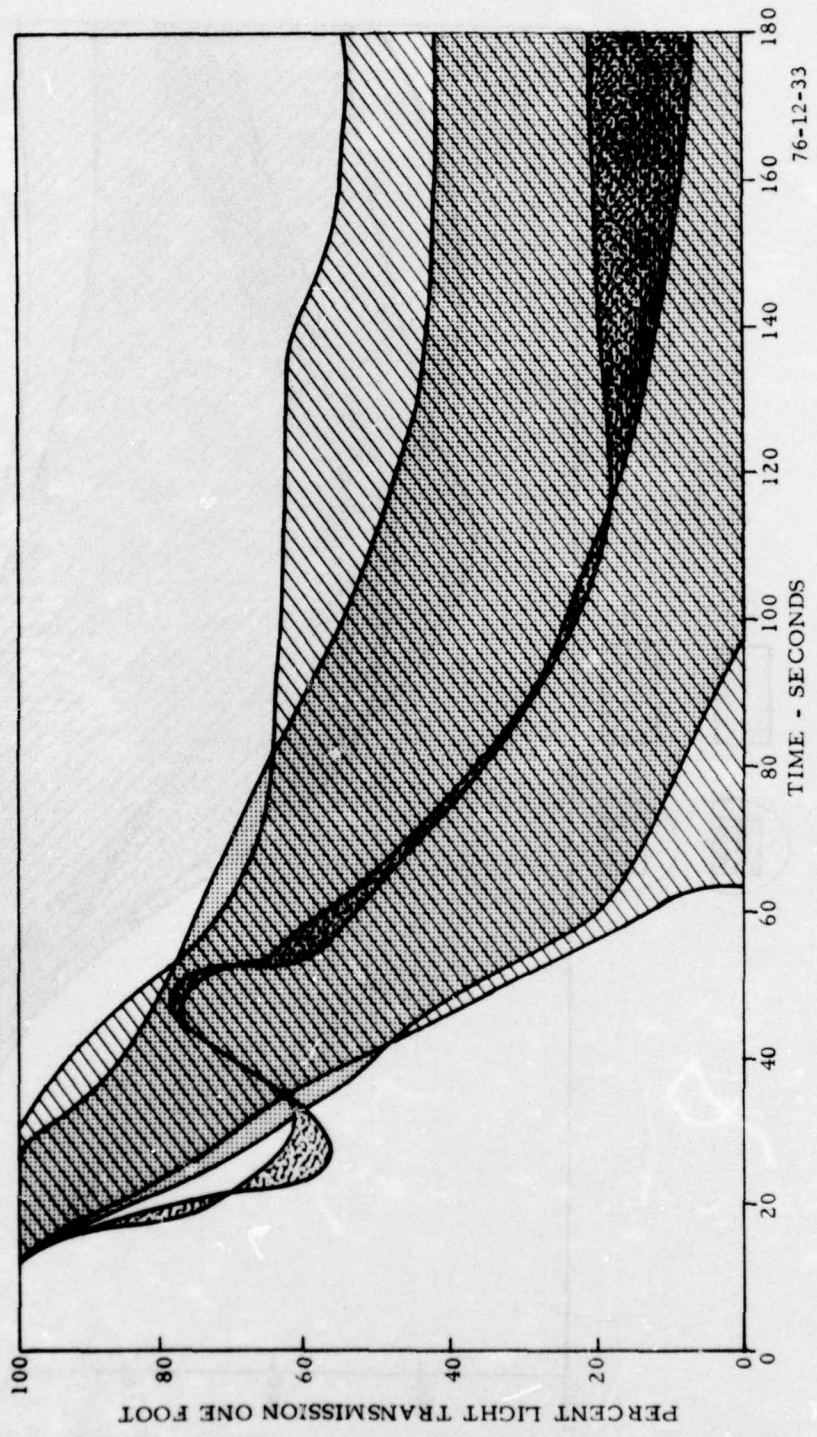
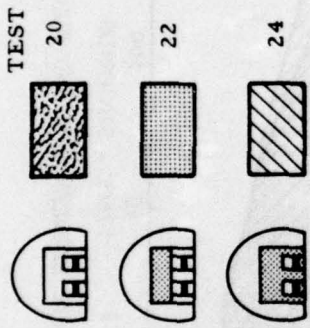

FIGURE 30. SMOKE RANGE BETWEEN AFT AND FORWARD (NO AIRFLOW)

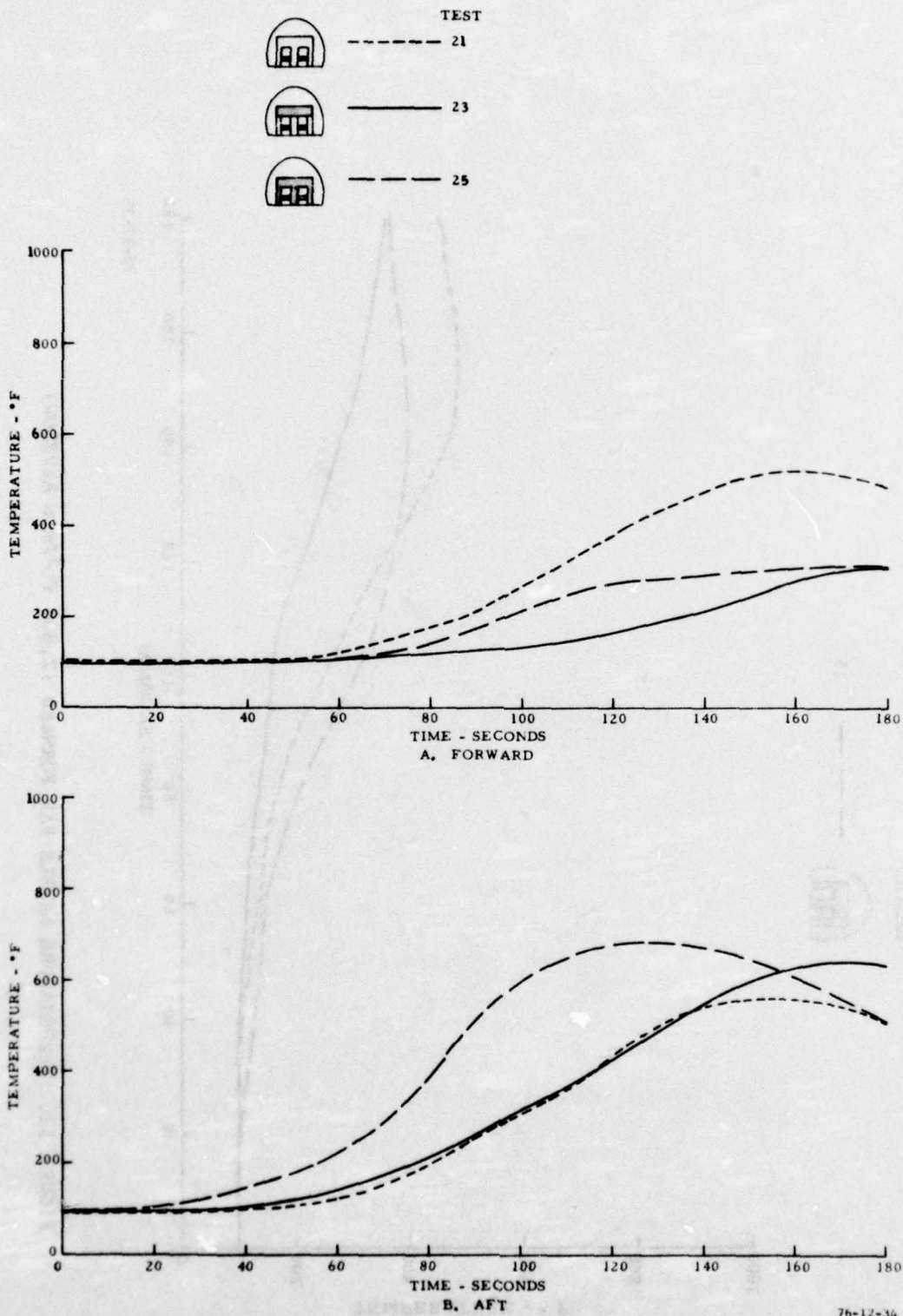
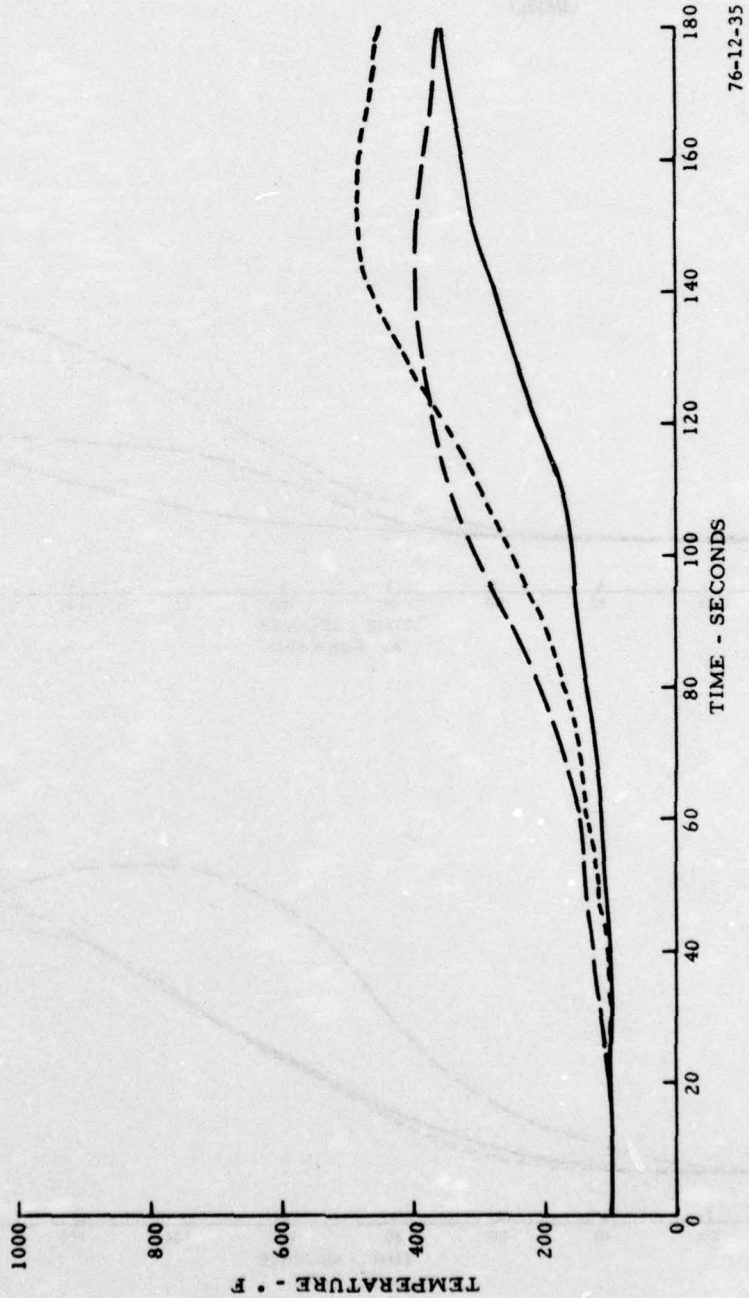
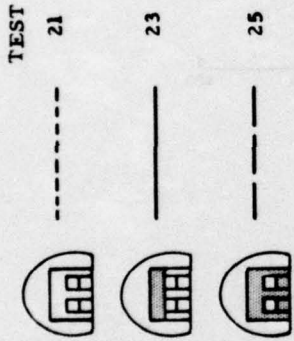

FIGURE 31. TEMPERATURE LEVELS WITH SEATS INSTALLED AT PARTITION (2,800 ft³/min AIRFLOW)

76-12-34



76-12-35

FIGURE 32. TEMPERATURE LEVELS FAR FORWARD (2,800 ft³/min AIRFLOW)

is made with figure 31A, there is an indication that the amount of protection can vary with location in the protected section of the fuselage. The temperature far forward (figure 32), for the curtain fully deployed, rises more sharply than either of the other two configurations for the first 2 minutes. However, the temperature in the fire zone (figure 31B) shows the temperature rise for the same configuration also to be raising more sharply than the other two. The partition configuration undoubtedly contributes to this result.

The level of protection from smoke followed a similar trend, as did thermal protection. Lower absolute levels were obtained with the curtain deployed to the seat backs. Although this is not what one may expect, again, the effect of the curtain configuration on fire dynamics cannot be discarded. Similarly, by comparing the forward and aft smoke levels for an individual test (figures 33A and 33B), the greatest difference occurs with the curtain extended to the floor, and the least, with no curtain.

SERIES V.

3-INCH HEADER TESTS. There were virtually no differences between the test data of a 3-inch header and no header, with or without airflow.

18-INCH HEADER TESTS. Very little difference in temperature was detected with the use of an 18-inch header, either with or without airflow. A degree of smoke protection was provided without airflow (figure 34) for the first minute. That protection was reduced and all but eliminated when airflow was supplied during the test (figure 34).

SERIES VI.

The sixth and final series of tests consisted of three airflow tests and five tests without airflow. An aircraft decorative-type partition was simulated, with openings at the top, sides, and bottom (figure 35). The amount of protection provided by that configuration and variations thereof were explored.

NO AIRFLOW. The results of the five tests conducted without airflow are shown in figures 36 through 39.

The results of the five tests were compared to that of test 20 which used no partition. It can be seen from figure 36 that the addition of any partition gives some thermal protection, and the larger the partition, the more protection provided. The oxygen concentration followed the same general trend as did the temperature. The least oxygen depletion on the protected side occurred with a fully closed curtain (figure 37), while the greatest occurred with the fully open configuration. Varying levels of oxygen depletion were recorded between the two extremes. The CO levels, as in the previous series, did not follow the trend of the temperature or O₂, but rather, the level of CO in the protected area increased as partial compartmentation was employed (figure 38). As before, this increase was not due to the inability of the configuration to restrict the flow of CO, but by the

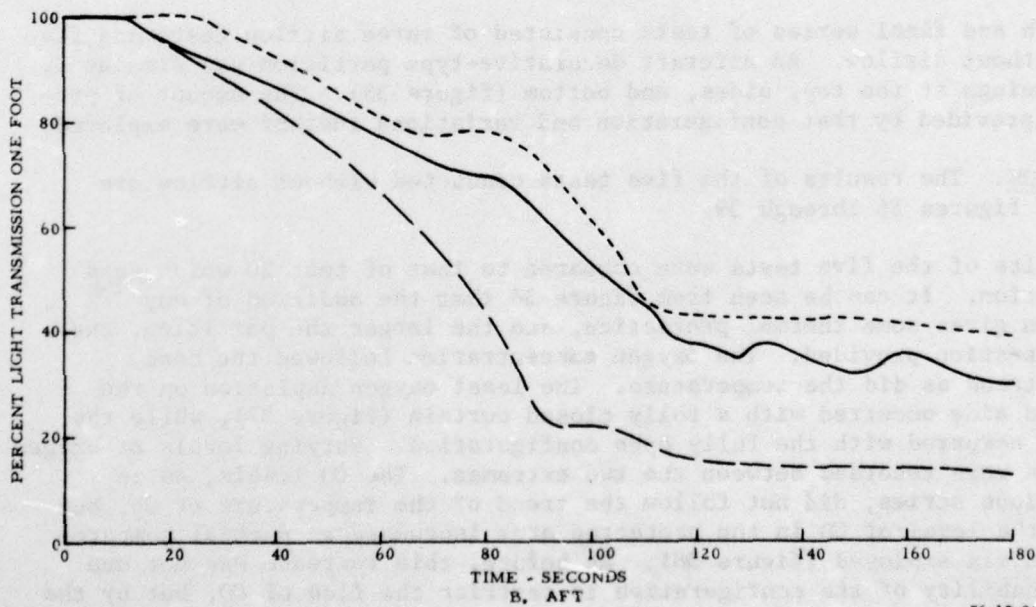
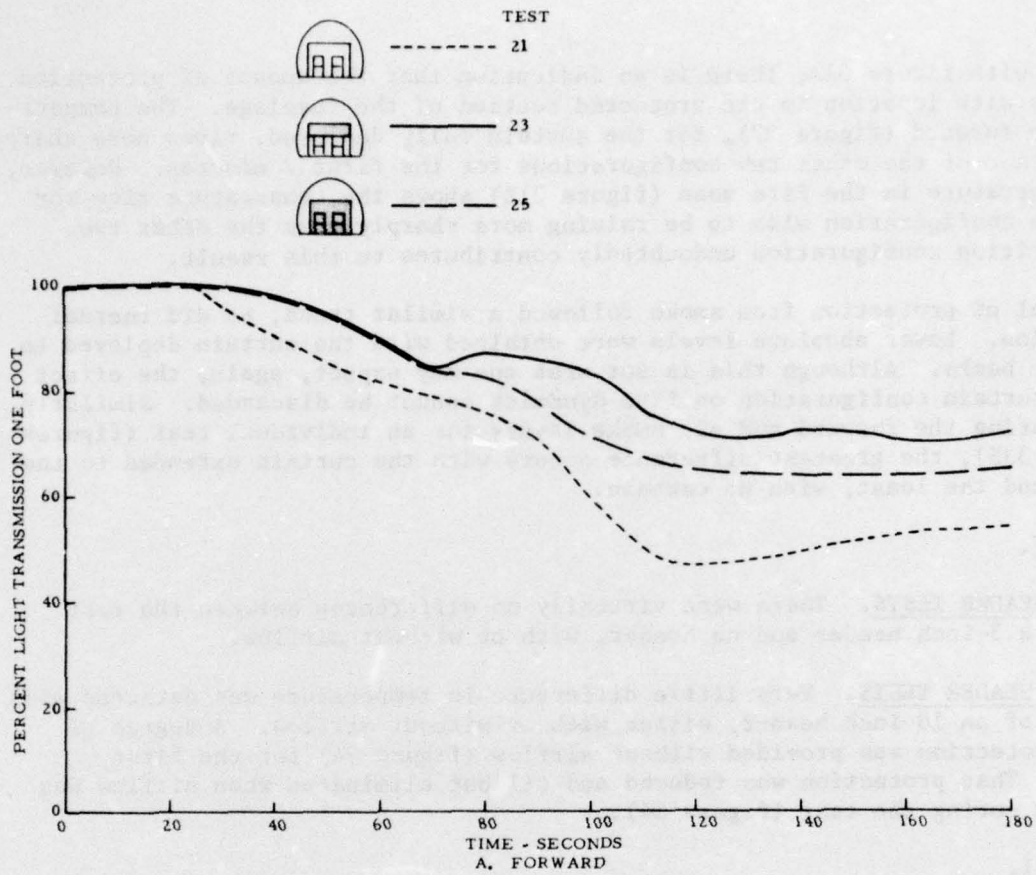

76-12-36

FIGURE 33. SMOKE LEVELS WITH SEATS INSTALLED AT PARTITION (2,800 ft³/min AIRFLOW)

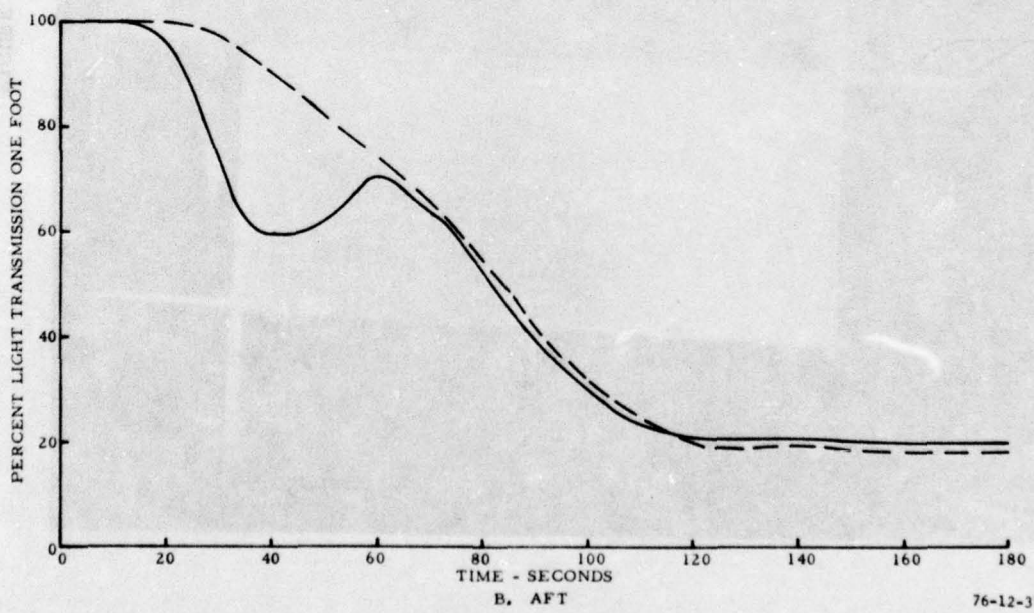
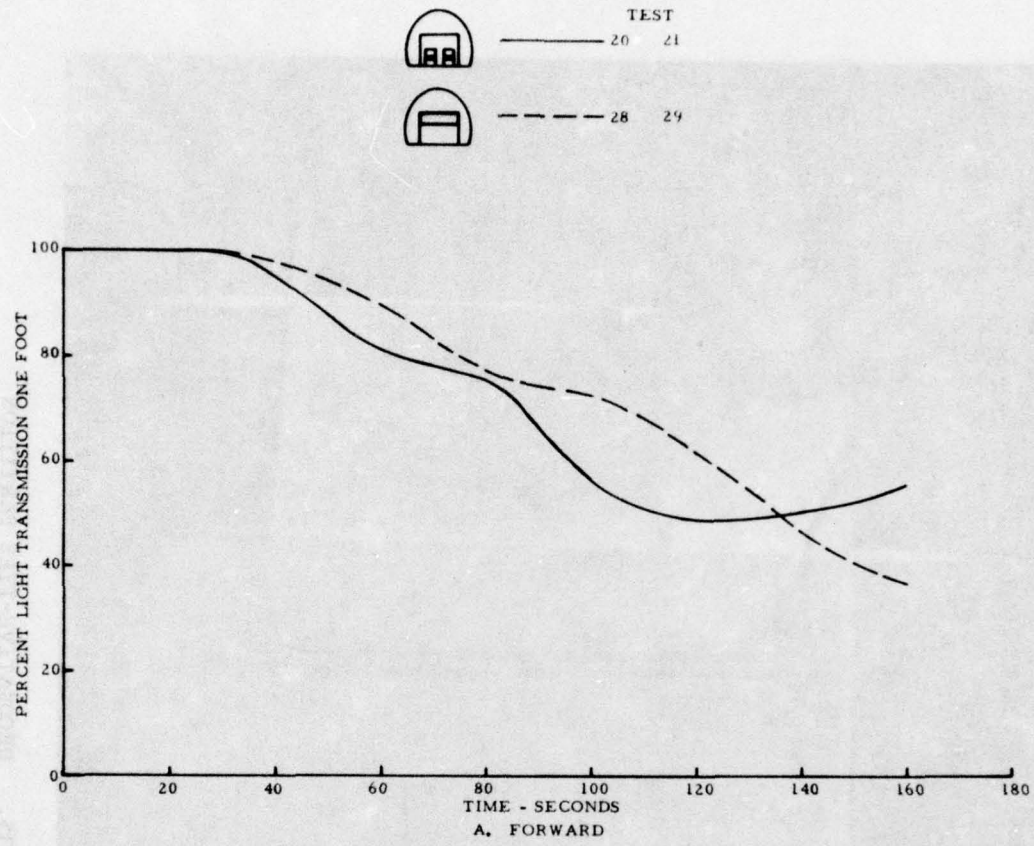

FIGURE 34. SMOKE LEVELS USING 18-INCH HEADER

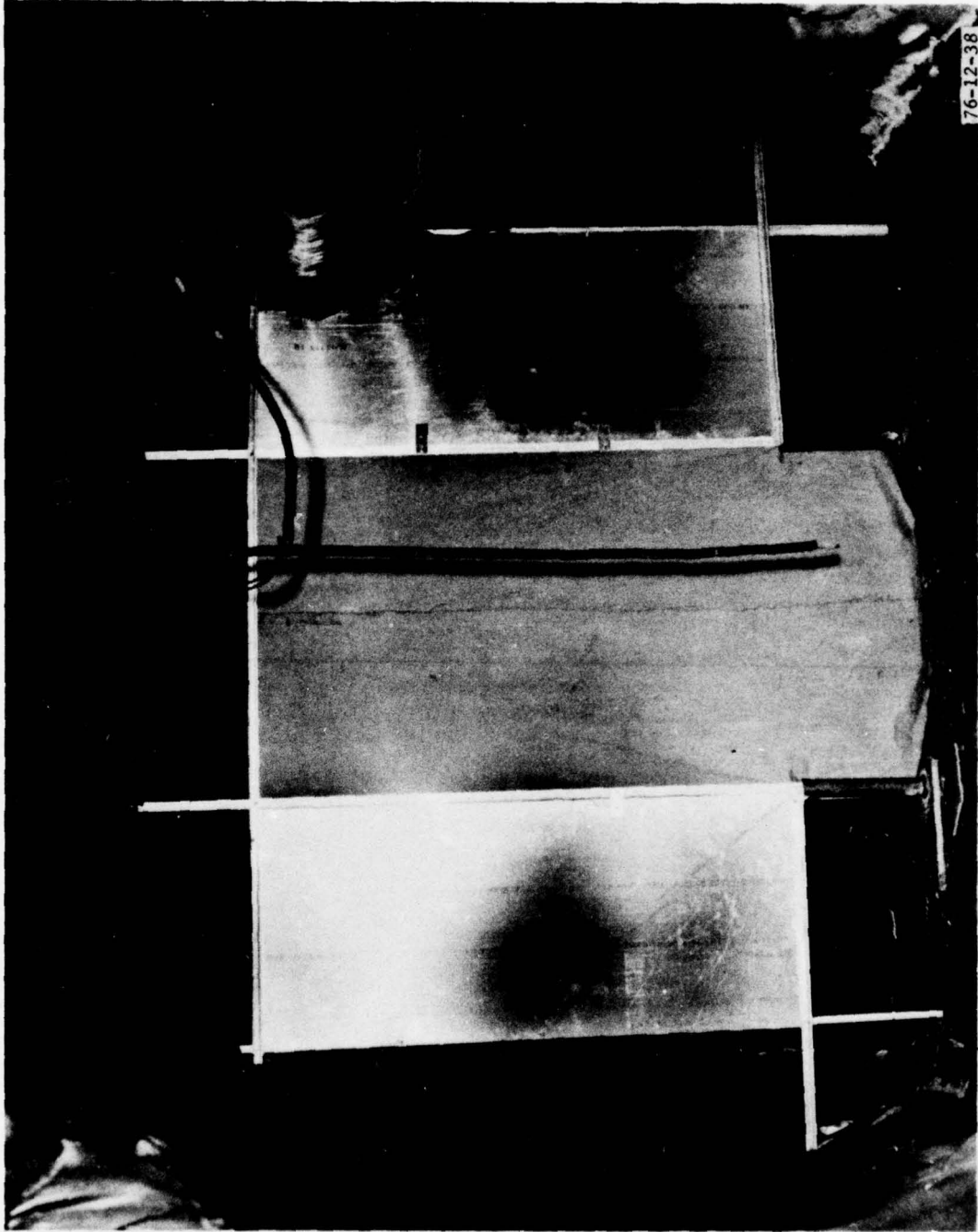

FIGURE 35. DECORATIVE-TYPE PARTITION

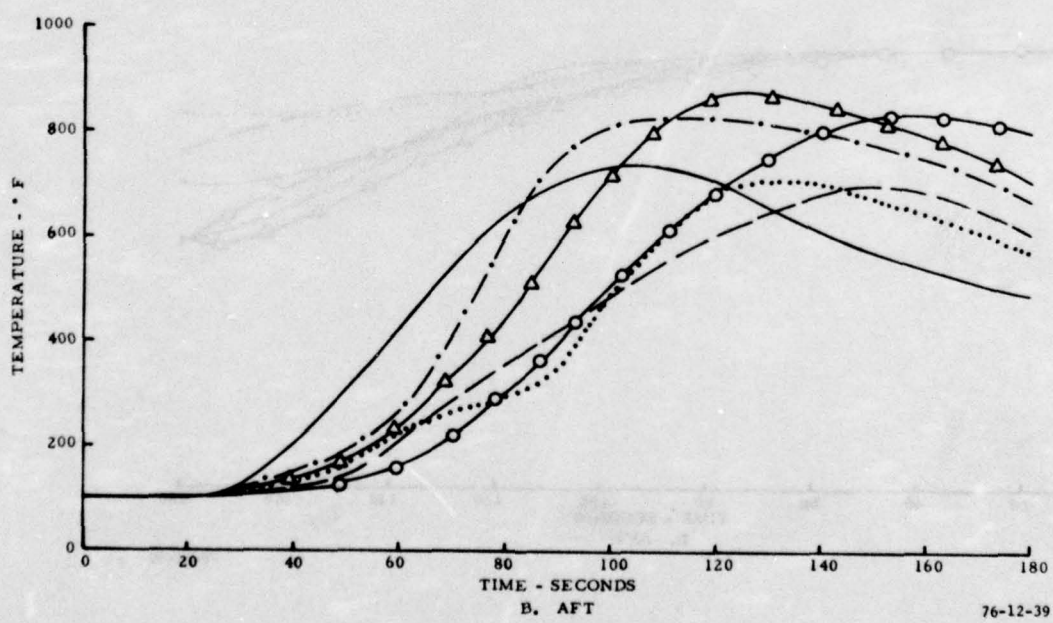
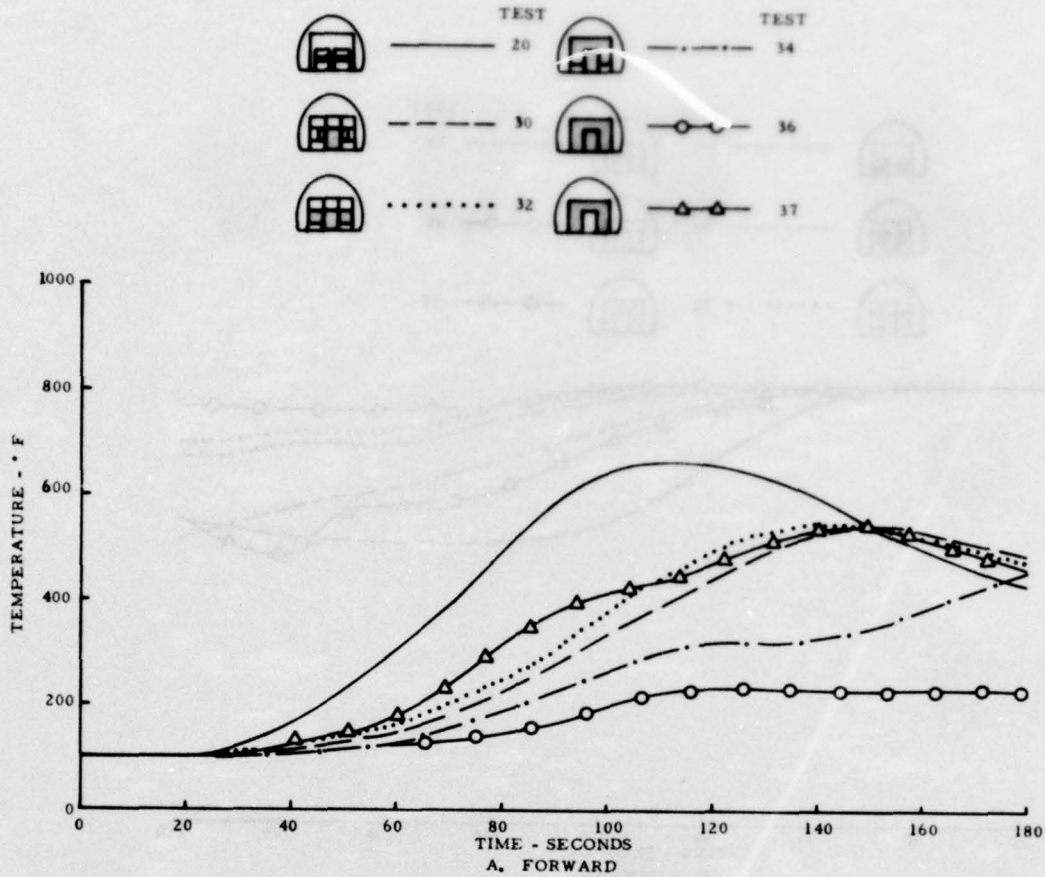
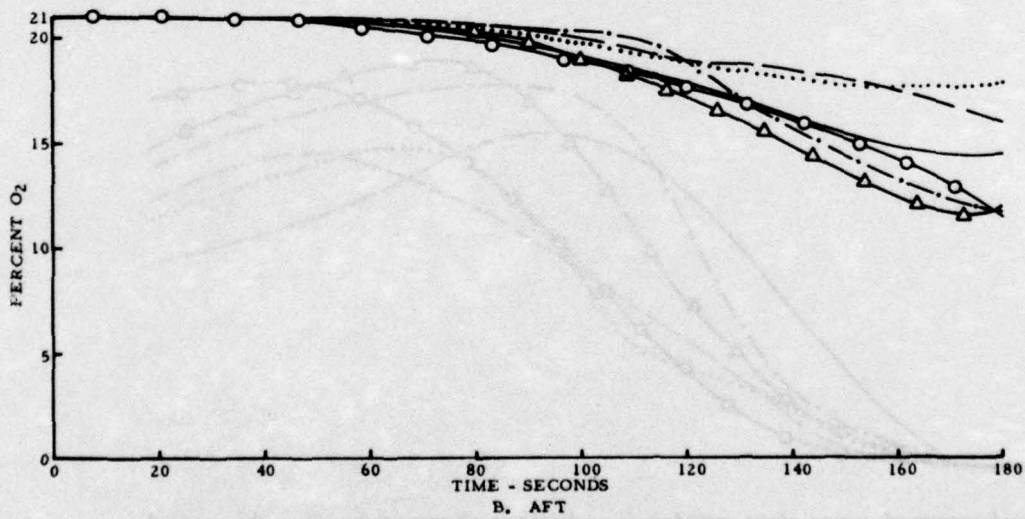
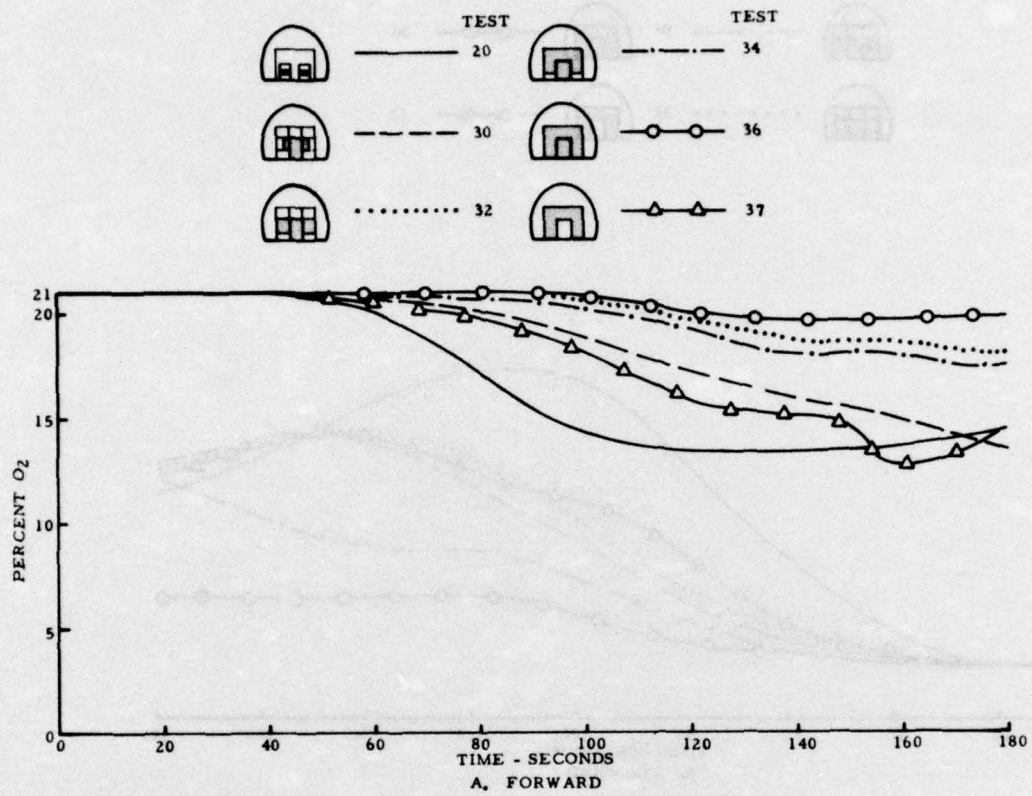

FIGURE 36. TEMPERATURE LEVELS USING DECORATIVE PARTITION (NO AIRFLOW)



76-12-40

FIGURE 37. OXYGEN LEVELS USING DECORATIVE-TYPE PARTITION (NO AIRFLOW)

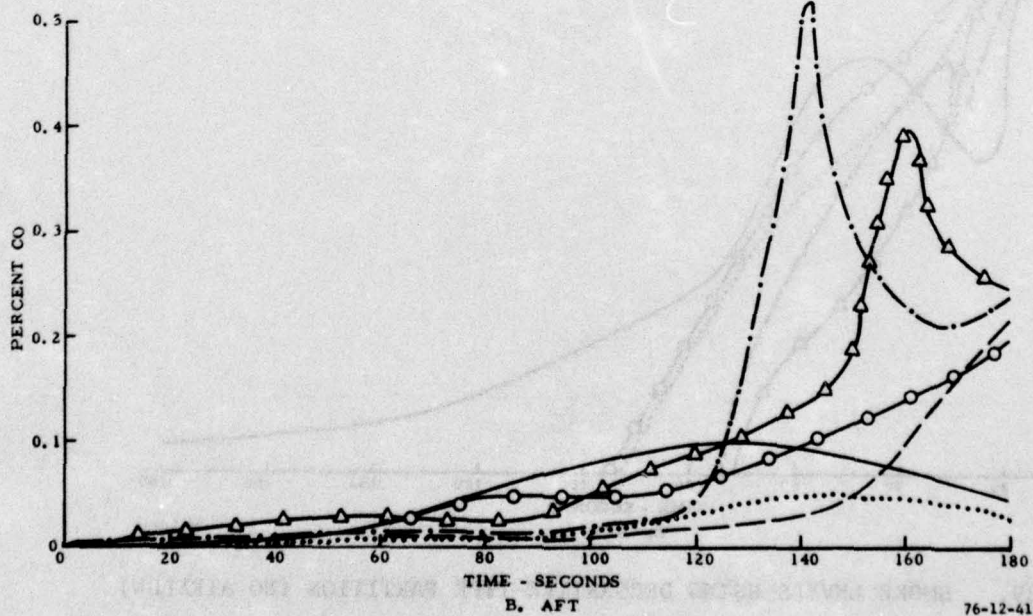
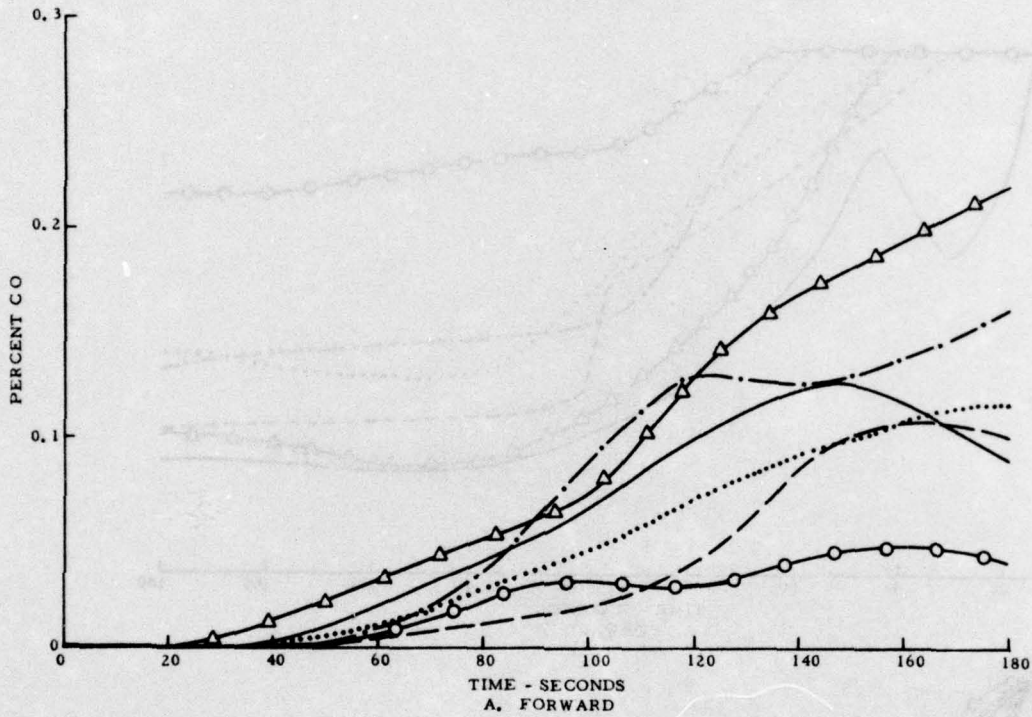
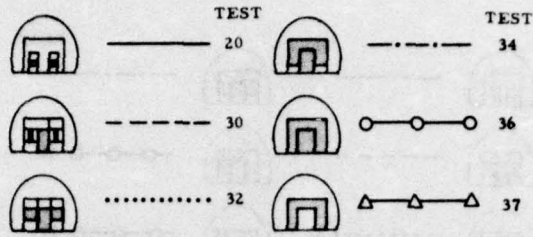

FIGURE 38. CO LEVELS USING DECORATIVE-TYPE PARTITION (NO AIRFLOW)

76-12-41

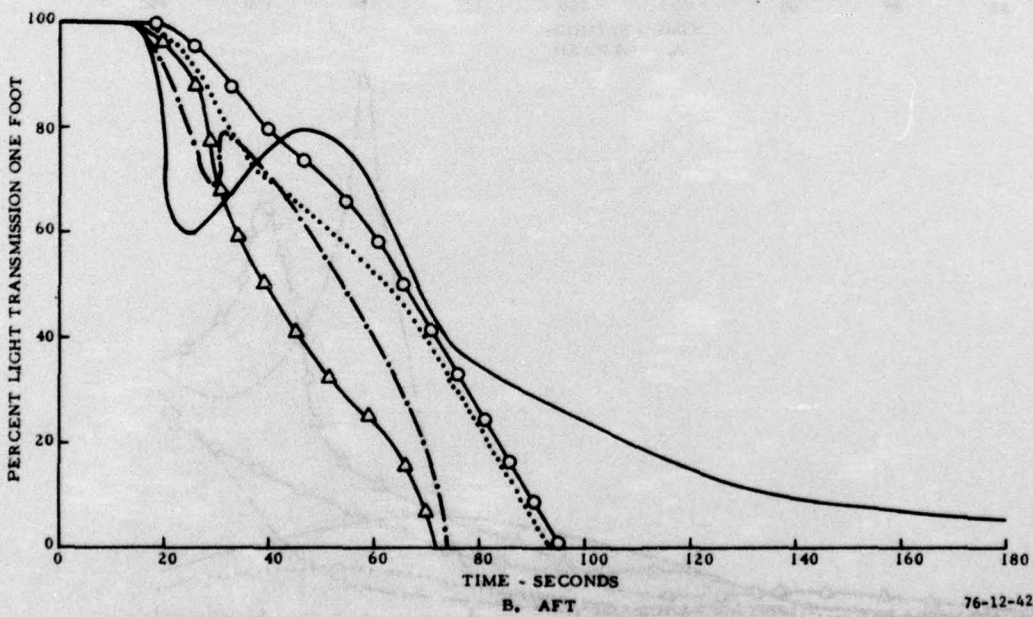
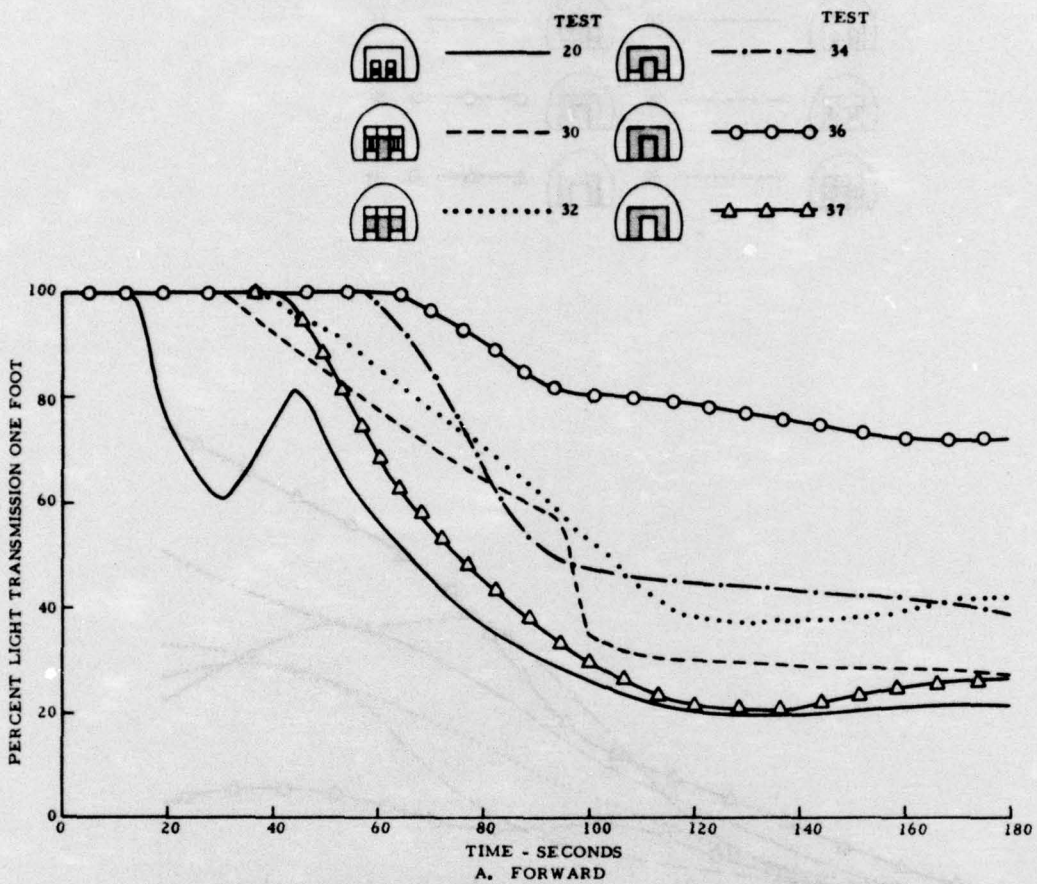

FIGURE 39. SMOKE LEVELS USING DECORATIVE-TYPE PARTITION (NO AIRFLOW)

effect of the configuration on the dynamics of the fire. When certain configurations were used, inhibiting free flow of oxygen to the fire load resulted in higher concentrations of CO produced. Smoke level data (figure 39) indicate that some protection can be realized with minimum partition size for a short time (up to 1 minute). Longer term protection was afforded as partition size increased, with the only configuration providing tolerable conditions after 2 minutes, being the fully closed partition and curtain.

2,800 ft³/min AIRFLOW. Similar to previous airflow tests, the partition configuration influences fire dynamics, indicating that, in some cases, better protection (i.e., lower levels) was obtained when no partition or curtain was used. Figure 40 illustrates that the best thermal protection was realized with no partition. It was apparent that the fire intensity and heat buildup were less when no partition was used. However, in comparing aft and forward zones at 90 seconds, the temperature difference was 30° F with no curtain; 120° F with the sides, top, and bottom of the partition open; 160° F with the top and bottom open; and 440° F when the bottom was open.

Airflow into the fuselage maintained oxygen concentration at relatively high levels on both sides of the partition, except for test 35 where the O₂ dropped below 15 percent on the fire side of the partition (figure 41). Due to the forced ventilation, the high oxygen level kept the CO concentrations low, and similar to other airflow tests, the highest concentration of CO resulted when the partition was largest in size installed (figure 42).

When comparing the smoke density of the four configurations on the protected side (figure 43A), the level of protection after 90 seconds increased with increasing partition size. Prior to 90 seconds, the data spread was not as great, except for test 33. As with temperature, the amount of smoke was a function of partition configuration. Figure 43 indicates that more smoke was produced in the aft zone when any type of partition was used, as compared to that when there was no partition. However, when a forward and aft comparison was made, a greater degree of protection was provided as the size of the partition was increased. At 60 seconds, the difference in light transmissions between the forward and aft section increased as the size of the partition increased. A 2-percent difference was noted with no partitions, and a 20-percent difference was noted using the partitions open at the bottom.

SUMMATION.

In order to best show the trend of smoke and temperature protection from the use of compartmentation, figures 44, 45, and 46 were developed. Figures 44 and 45 represent the change in protection, 3 feet from the partition in the protected section, as the amount of partitioning was increased.

Figure 44 curves depict a no airflow condition and show a very impressive increase in protection as the size and tightness of the curtain was increased. The time to reach 250° F doubled for a closed and taped curtain as compared to an open fuselage. For the same conditions, the time to reach 85-percent light transmission differed by a factor of six.

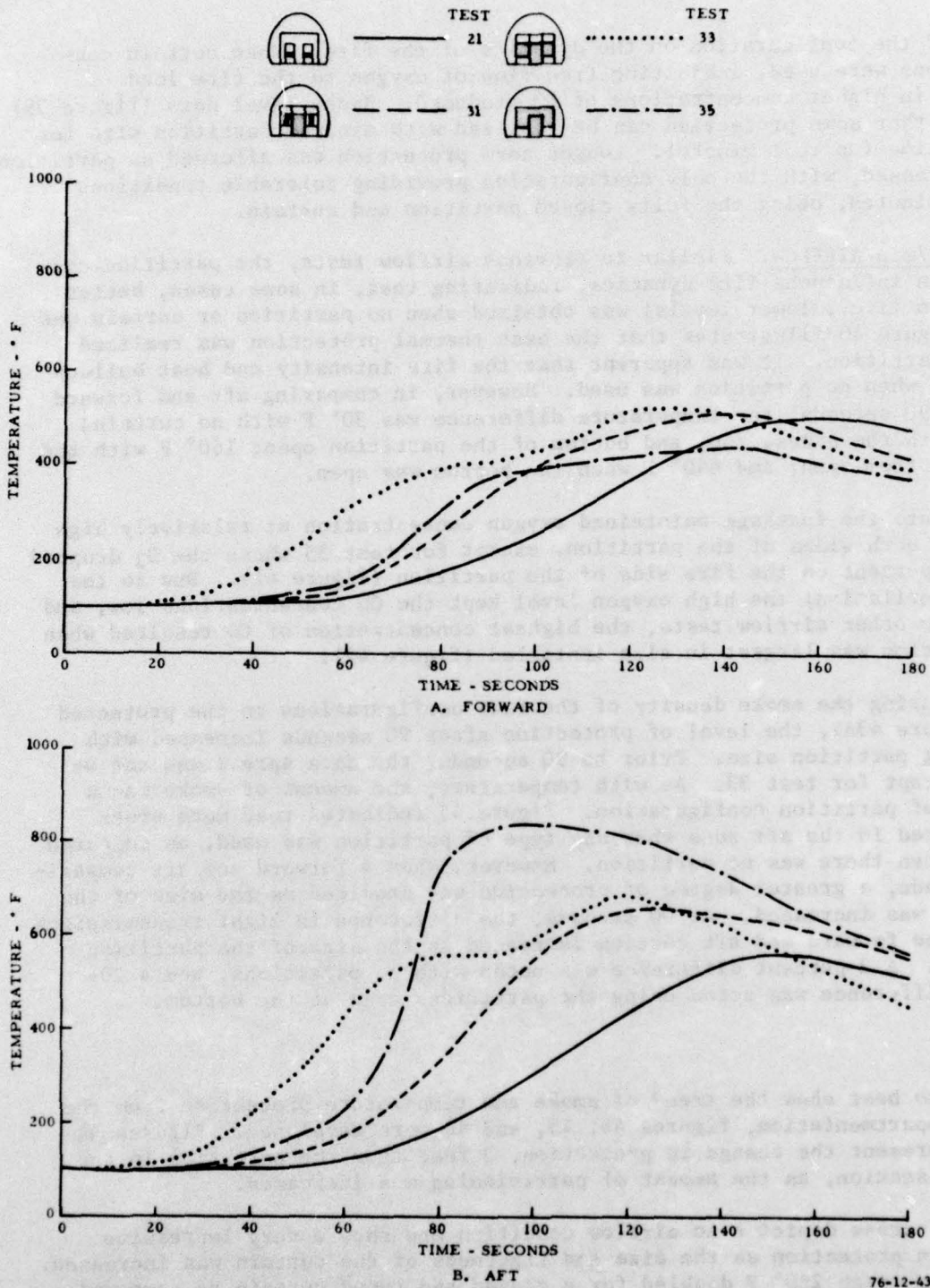

FIGURE 40. TEMPERATURE LEVELS USING DECORATIVE-TYPE PARTITION (2,800 ft³/min AIRFLOW)

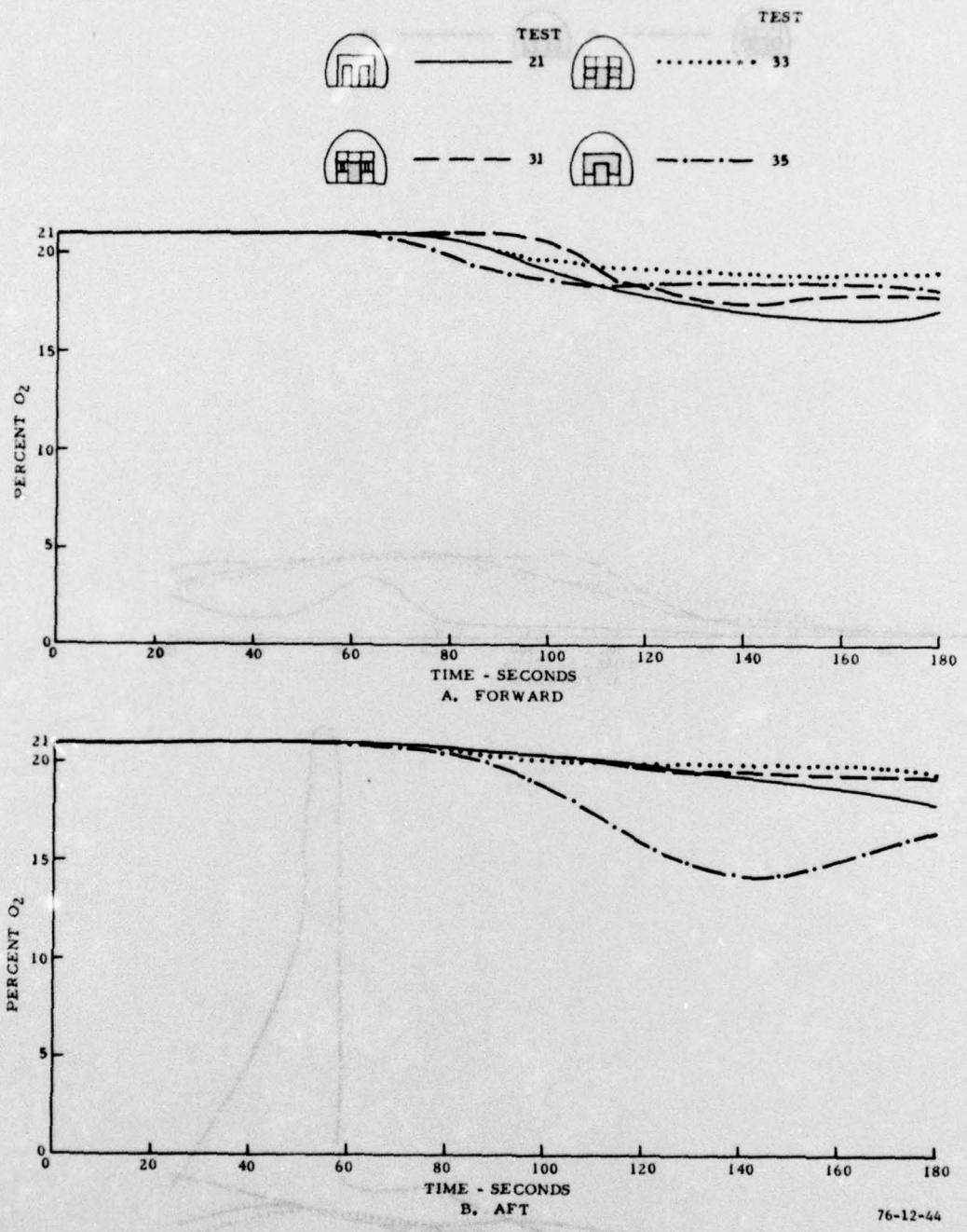

FIGURE 41. OXYGEN LEVELS USING DECORATIVE-TYPE PARTITION (NO AIRFLOW)

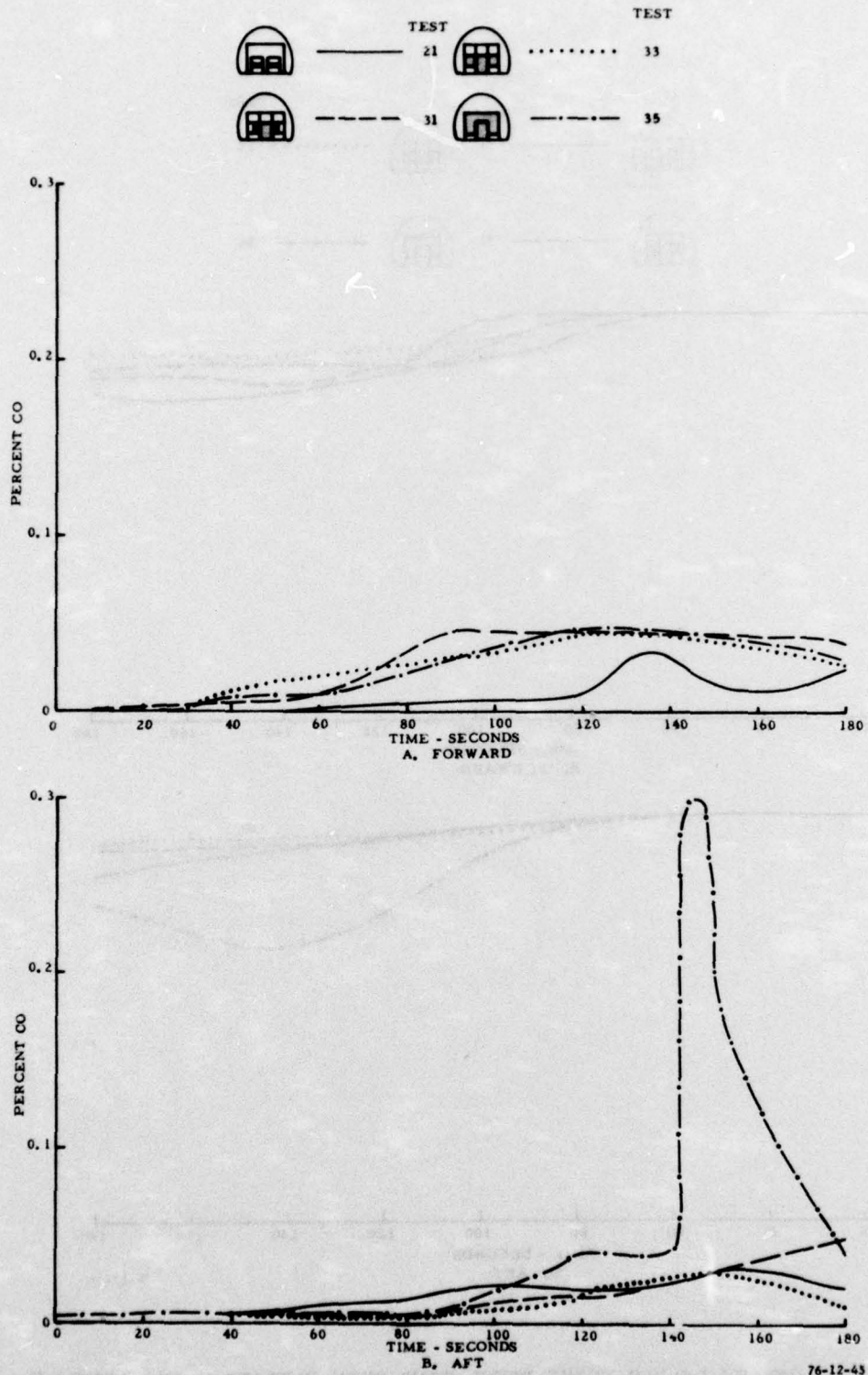
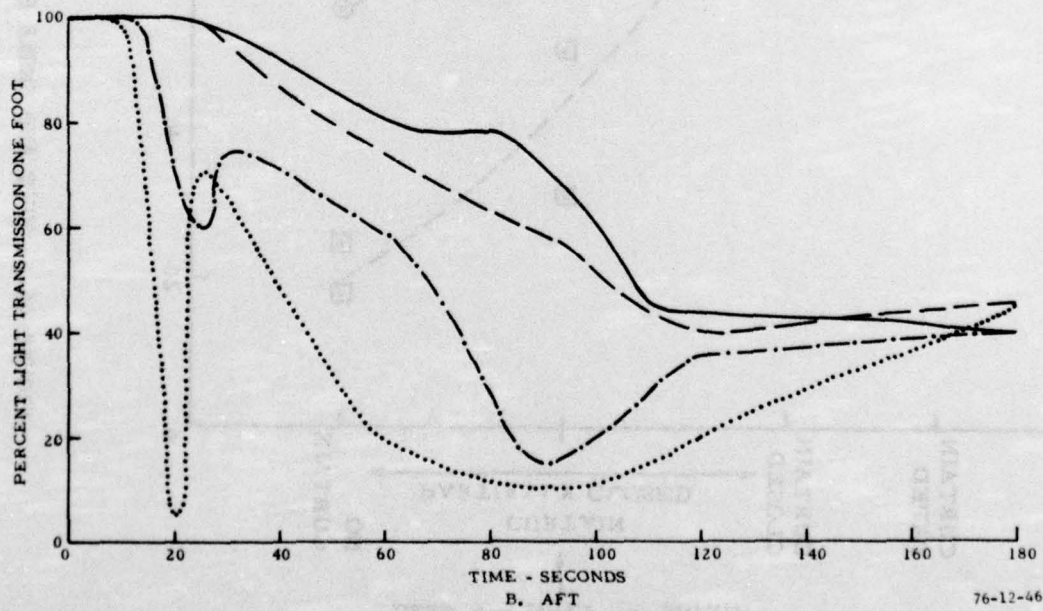
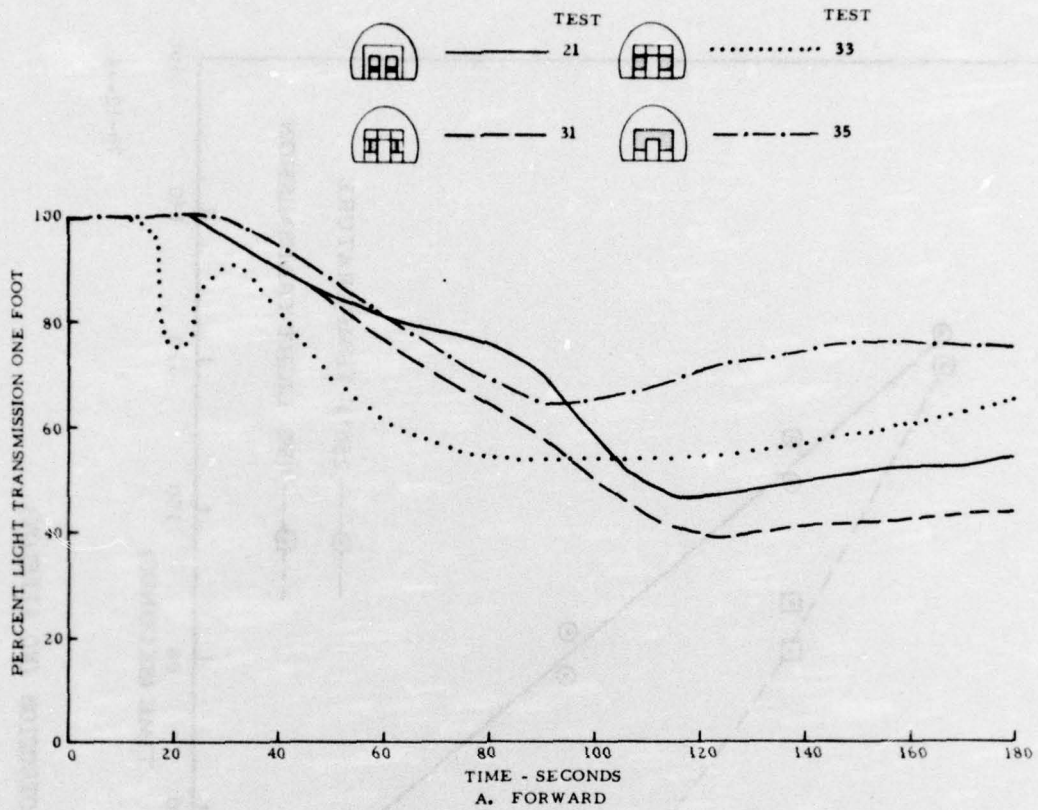
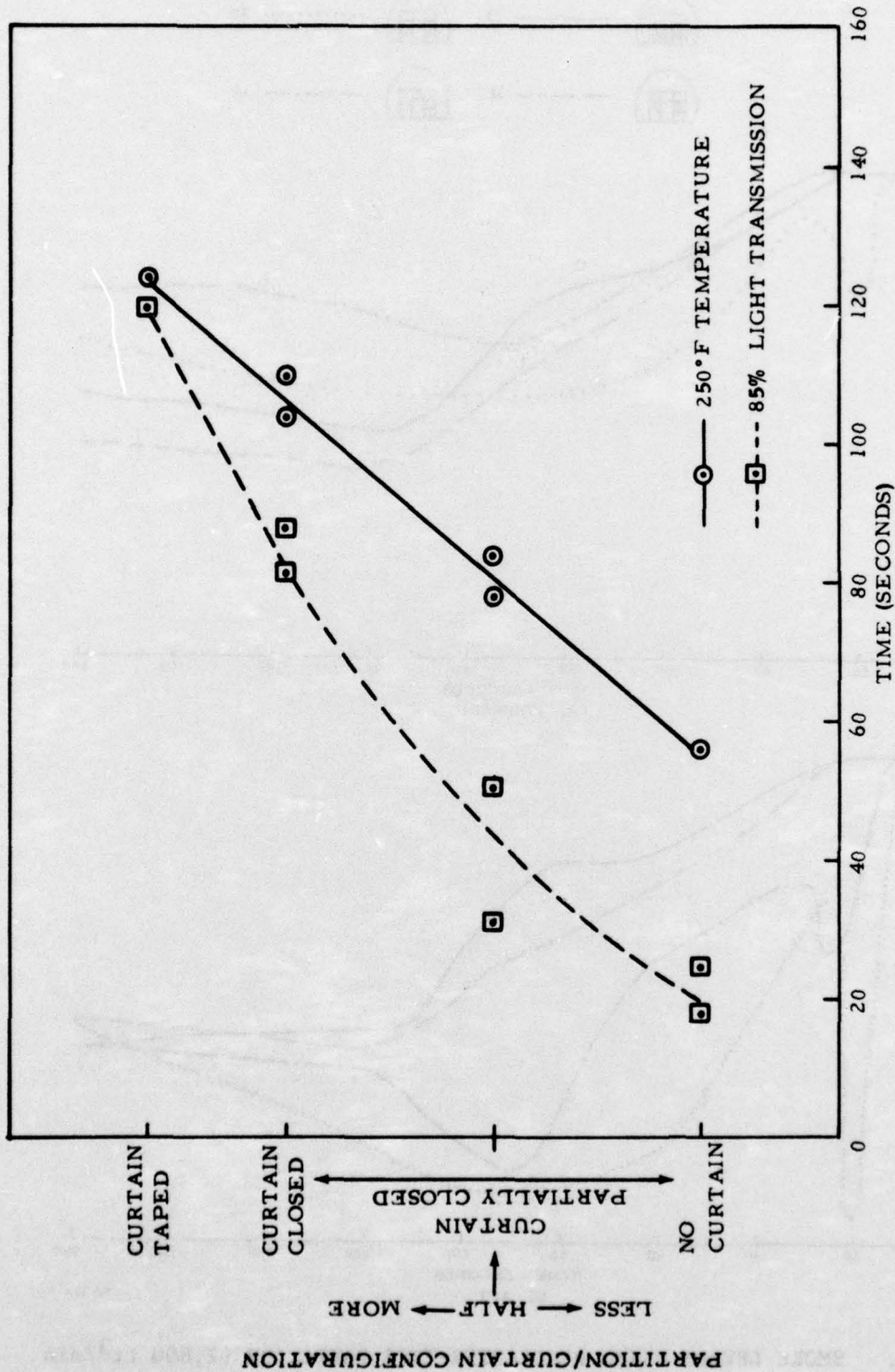

FIGURE 42. CO LEVELS USING DECORATIVE-TYPE PARTITION (2,800 ft³/min AIRFLOW)



76-12-46

FIGURE 43. SMOKE LEVELS USING DECORATIVE-TYPE PARTITION (2,800 ft³/min AIRFLOW)



76-12-44

FIGURE 44. HEAT AND SMOKE PROTECTION (NO AIRFLOW)

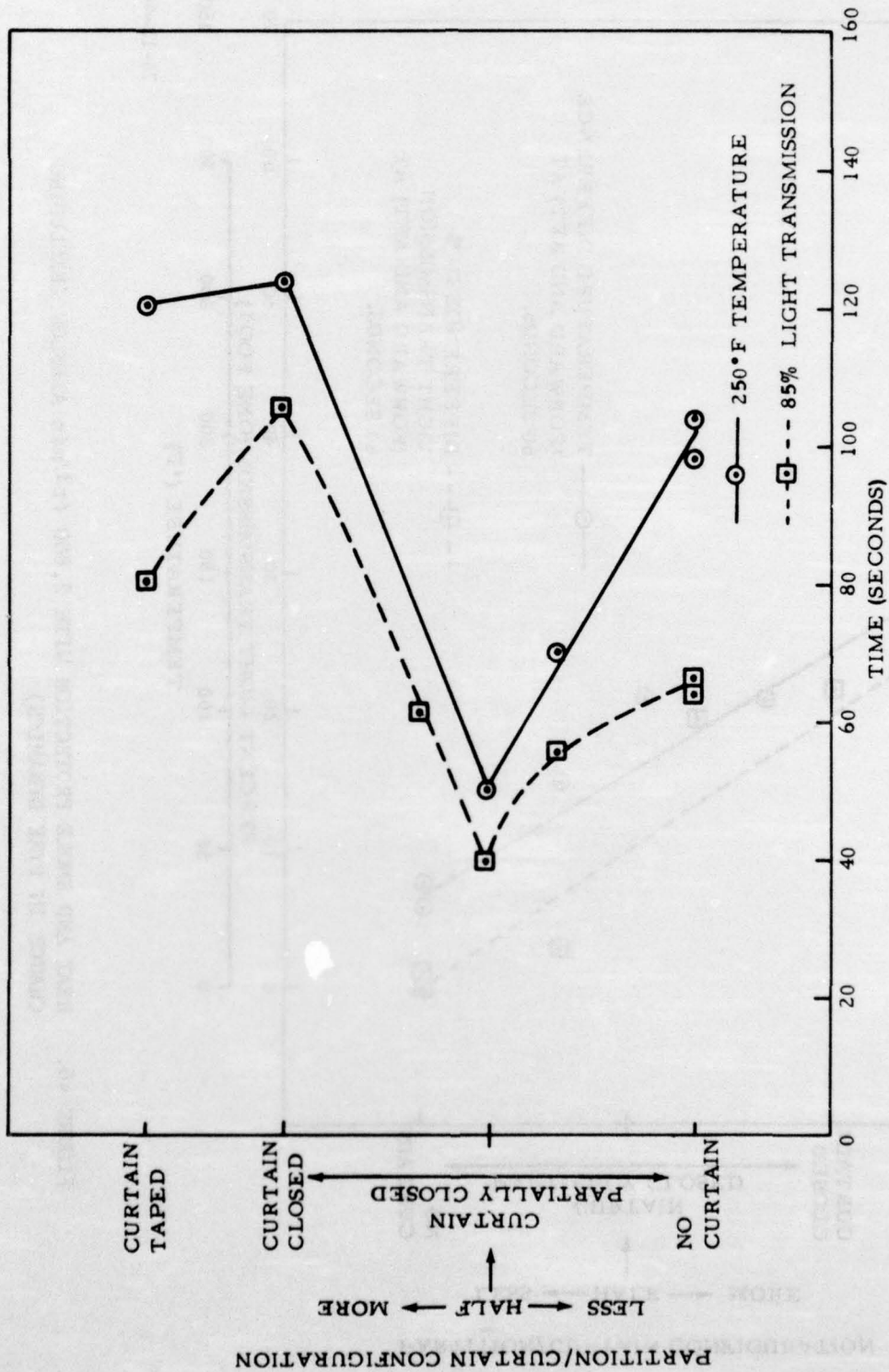

76-12-45

FIGURE 45. HEAT AND SMOKE PROTECTION WITH 2,800 ft³/min AIRFLOW (INCLUDING CHANGE IN FIRE DYNAMICS)

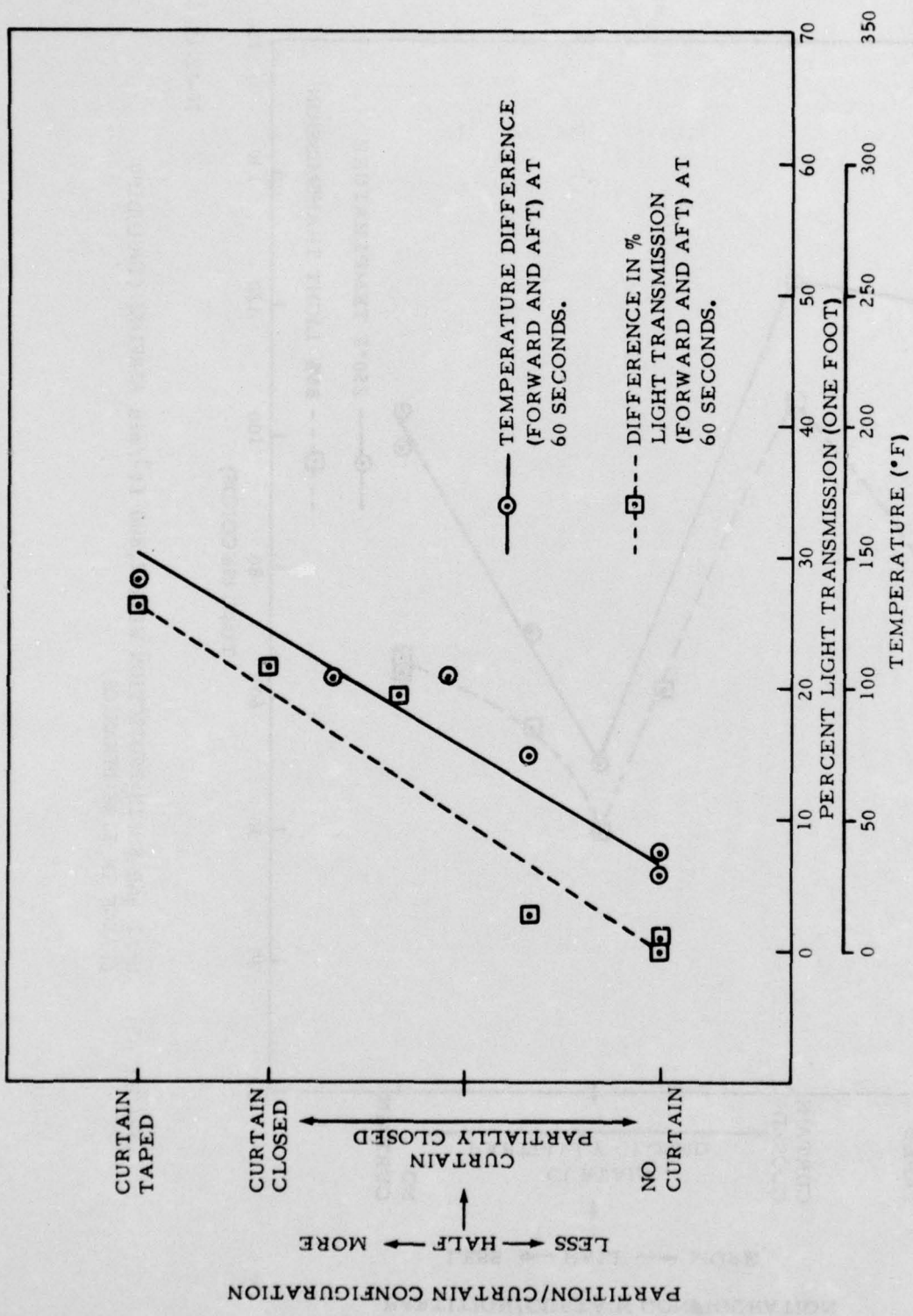

76-12-46

FIGURE 46. HEAT AND SMOKE PROTECTION WITH 2,800 ft³/min AIRFLOW (EXCLUDING CHANGE IN FIRE DYNAMICS)

PARTITION/CURTAIN CONFIGURATION

LESS → HALF → MORE

With a 2,800 ft³/min airflow, the protection provided from an interior fire did not always increase as the size and tightness of a partition/curtain was increased. As shown in figure 45, the times to reach 250° F and 85-percent light transmission decreased as the partition/curtain size increased, until the partition/curtain size was greater than half the cross sectional area of the fuselage; at which point, the amount of protection began to increase. The cause for this erratic behavior was not the inability of the partition/curtain to stop the heat and smoke, but the change in fire dynamics when compartmentation was used. This can be seen in figure 46, where a comparison was made between the smoke and temperature levels forward and aft of the partition/curtain for the same tests as shown in figure 45. The amount of protection provided from one side of the partition/curtain to the other during the same test increased as the size and tightness of the partition/curtain increased; thus indicating that a partition and/or curtain can provide an effective fire/gas barrier, but can also change the intensity of an internal fire and, under some conditions, reduce the overall escape time.

SUMMARY OF RESULTS

1. The use of any partition or curtain in the aircraft cabin altered fire dynamics, circulation propensities, and heat transfer between fire and nonfire zones during the internal fuselage fire.
2. In the absence of forced ventilation, the degree of protection from temperature, smoke, and oxygen depletion was a function of the size of the partition and/or curtain. The greatest degree of protection was obtained with a fully closed and taped curtain. The least protection occurred with no partition.
3. With no forced ventilation, CO concentrations in both the protected and fire section were highest when partitions and/or curtains were used.
4. With no forced ventilation, the difference between the CO levels in the protected and fire section increased as the size of the partition increased.
5. With and without forced ventilation, an 18-inch header provided a slight amount of smoke protection, but little or no protection against heat, CO, or oxygen depletion.
6. With airflow, in some cases, more protection was provided when no curtain was used, and the amount of protection decreased as the size of the partition was increased. This was due to the fact that the partitions changed the dynamics of the fire, creating a more intense fire as the size of the partition was increased.
7. When a comparison was made between the forward and aft levels of smoke, temperature, O₂, and CO with airflow, the results showed that a greater difference was obtained as the size of the partition and/or curtain was increased. Therefore, if the dynamics of the fire were not effected by the compartmentation (such as an external fire entering the cabin), the larger the partition, and the tighter it was sealed, the greater was the protection provided in forward zone.

CONCLUSIONS

1. Compartmentation and forced ventilation affect the combustion characteristics and fire dynamics of an internal fuselage fire. Compartmentation provides protection when the fire is not changed by the compartment configuration (that is, an external fire) or where the amount of hazards stopped by the configuration exceeds the added amount produced by the change in fire intensity.
2. The protection against temperature, smoke, and O₂ depletion, with little or no airflow, is a function of partition size, with the best being a tightly sealed partition and/or curtain. In a few cases (especially involving CO), the effects of the partition on the intensity of the fire can overshadow the effects of the partition on increasing the hazards on the protected side of the partition.
3. A large increase in theoretical escape time can be obtained by using compartmentation for both an internal and external fire, if little or no airflow is present.

REFERENCES

1. CAB Accident Report, File No. 1-0003, July 20, 1962.
2. Snow, Clyde C., Carroll, John J., and Allgood, Mackie A., Survival in Emergency Escape From Passenger Aircraft, FAA Report No. AM 70-16, Oct. 1970.
3. Leroy, C. Haden, Survival Study: Modern Commercial Jet Aircraft Landing Accident with Subsequent Interior Fire, presented to the Aerospace Med. Assn. 38th Annual Scientific Meeting, April 11, 1967.
4. Aircraft Accident Report, NTSB-AAR-74-15, November 8, 1974.
5. Aircraft Accident Report, NTSB-72-20, June 1, 1972.
6. Anonymous, Fire Suppression, and Smoke and Fume Protection, Aerospace Industries Association of America, Inc., Report AIA-CDP-2.
7. Marcy, J. F., Air Transport Cabin Mockup Fire Experiments, Federal Aviation Administration, NAFEC, Report FAA-RD-70-81, December 1970.
8. Armstrong, Maj. Gen. Harry G., Aerospace Medicine, Williams and Wilkens Co., Baltimore, 1961.
9. Kimmerle, George Dr. Med., Aspects and Methodology for the Evaluation of Toxicological Parameters During Fire Exposure, JFF/Combustion Toxicology, Vol. I, Feb. 1974, p. 4-51.
10. Schulte, John H., Effects of Mild Carbon Monoxide Intoxication, Archives of Environmental Health, Vol. 7, Nov. 1963, p. 524 -530.
11. Fire Protection Handbook, 13th ed., 1969.
12. Briodu, A. and McMasters, A. W., Effects of Mass Fires on Personnel in Shelters, USDA, Tech. Rpt. No. 50, Aug. 1960.
13. Forbes, W. N., Sargent, F., and Roughton, F. J. W., The Rate of Carbon Monoxide on Uptake by Normal Men, American Journal of Physiology, Vol. 143, 1945, p. 594-608, pp. 167-176.
14. Stewart, Richard D., The Effect of Carbon Monoxide on Man, JFF/Combustion Toxicology, Vol. I, Aug. 1974, pp. 167-197.
15. Kishitani, K., Study on Injurious Properties of Combustion Products of Building Materials at Initial Stages of Fire, Journal of Faculty Engineering, University of Tokyo, 1971.
16. Sullwan, T., Systematic Action of Gases, A Manual of Pharmacology, 7th ed., W. B. Saunders Co., Philadelphia, 1948.

17. Pryor, A. J. and Yuill, C. H., Mass Fire Life Hazard, Southwest Research Institute, San Antonio, Tex., Report AD642790, Sept. 1966.
18. Buettner, Konrad, Effects of Extreme Heat on Man, Journal of American Medical Association, Oct. 28, 1950, pp 732-738.
19. Pessman, Gerard J., Appraisal of Hazards to Human Survival in Airplane Crash Fires, NACA TN 2996, Sept. 1953.
20. Report of Evacuation, CAB Report SA-388, File No. 1-0032, Exhibit 6-B, Feb. 3, 1966.
21. Connolly, Donald W., Postcrash Fire Fighting Studies on Transport Category Aircraft, SRDS Report No. RD-65-50, May 1965.