

AD-A033 062

BOEING AEROSPACE CO SEATTLE WASH
INTEGRATED PROPULSION CONTROL SYSTEM. VOLUME IV. METHODOLOGY.(U)
AUG 76 L O BILLIG

F/G 21/5

F33615-73-C-2035

UNCLASSIFIED

AFAPL-TR-76-61-VOL-4

NL

1 OF 2
AD
A033062



THIS REPORT HAS BEEN DELIMITED
AND CLEARED FOR PUBLIC RELEASE
UNDER DOD DIRECTIVE 5200.20 AND
NO RESTRICTIONS ARE IMPOSED UPON
ITS USE AND DISCLOSURE.

DISTRIBUTION STATEMENT A

APPROVED FOR PUBLIC RELEASE;
DISTRIBUTION IS UNLIMITED.

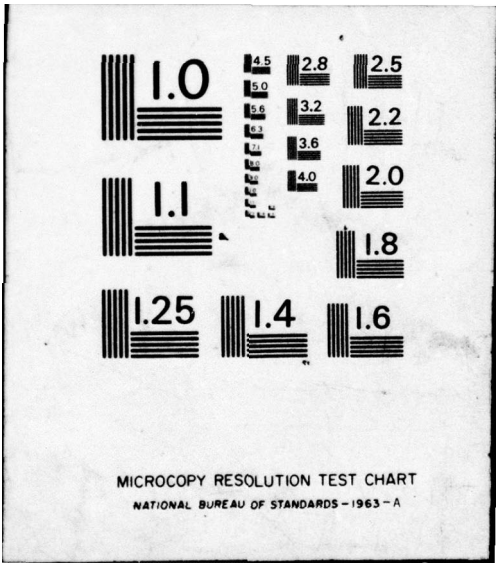

MICROCOPY RESOLUTION TEST CHART
NATIONAL BUREAU OF STANDARDS - 1963 - A

ADA 033062

AFAPL-TR-76-61
VOLUME IV

12

**INTEGRATED PROPULSION CONTROL SYSTEM (IPCS)
FINAL REPORT
VOLUME IV
METHODOLOGY**

**BOEING AEROSPACE COMPANY
P.O. BOX 3999
SEATTLE, WA. 98124**

AUGUST 1976

**TECHNICAL REPORT AFAPL-TR-76-61 VOLUME IV
FINAL REPORT FOR PERIOD 1 MARCH 1973 - 30 AUGUST 1976**

Approved for public release; distribution unlimited

DDC
RECEIVED
DEC 6 1976
RECEIVED
A

**COPY AVAILABLE TO DDC DOES NOT
PERMIT FULLY LEGIBLE PRODUCTION**

**AIR FORCE AERO-PROPULSION LABORATORY
AIR FORCE WRIGHT AERONAUTICAL LABORATORIES
AIR FORCE SYSTEMS COMMAND
WRIGHT-PATTERSON AIR FORCE BASE, OHIO 45433**

NOTICE

When Government drawings, specification, or other data are used for any purpose other than in connection with a definitely related Government procurement operation, the United States Government thereby incurs no responsibility nor any obligation whatsoever; and the fact that the government may have formulated, furnished or in any way supplied the said drawings, specifications, or other data, is not to be regarded by implication or otherwise as in any manner licensing the holder or any other person or corporation, or conveying any rights or permission to manufacture, use, or sell any patented invention that may in any way be related thereto.

This final report was submitted by Boeing Aerospace Company, under contract F33615-73-C-2035. The effort was sponsored by the Air Force Aero Propulsion Laboratory, Air Force Systems Command, Wright-Patterson AFB, Ohio under Project Number 3066, Task Number 03 and Work Unit Number 42 with Joseph J. Batka, AFAPL/TBC as Project Engineer. Mr. G. W. N. Lampard of Boeing Aerospace Company was technically responsible for the work.

This report has been reviewed by the Information Office, (ASD/OIP) and is releasable to the National Technical Information Service (NTIS). At NTIS, it will be available to the general public, including foreign nations.

This technical report has been reviewed and is approved for publication.

Joseph J. Batka
JOSEPH J. BATKA
Project Engineer

FOR THE COMMANDER

Charles E. Bentz
CHARLES E. BENTZ
Technical Area Manager - Controls

BY	DATE
DISTRIBUTION/AVAILABILITY CODES	
Dist.	Avail. and/or special
A	

Copies of this report should not be returned unless return is required by security considerations, contractual obligations, or notice on a specific document.

UNCLASSIFIED

SECURITY CLASSIFICATION OF THIS PAGE (When Data Entered)

19 REPORT DOCUMENTATION PAGE		READ INSTRUCTIONS BEFORE COMPLETING FORM
1. REPORT NUMBER AFAPL-TR-76-61-Vol [redacted] - 4	2. GOVT ACCESSION NO.	3. RECIPIENT'S CATALOG NUMBER
4. TITLE (and Subtitle) Integrated Propulsion Control System, Final Report, Volume IV, METHODOLOGY.		5. TYPE OF REPORT & PERIOD COVERED Technical Report (Final) 1 Mar 73-30 August 76
7. AUTHOR(s) Leon O. Billig		6. PERFORMING ORG. REPORT NUMBER
9. PERFORMING ORGANIZATION NAME AND ADDRESS Boeing Aerospace Company P. O. Box 3999 Seattle, WA 98124		8. CONTRACT OR GRANT NUMBER(s) F33615-73-C-2035
11. CONTROLLING OFFICE NAME AND ADDRESS Air Force Aero-Propulsion Laboratory (AFAPL/TBC) Air Force System Command Wright Patterson AFB OH 45433		10. PROGRAM ELEMENT PROJECT, TASK AREA & WORK UNIT NUMBERS P.E. 62203F, PROJ 3066/Task 306603, W.U. 30660342
14. MONITORING AGENCY NAME & ADDRESS (if different from Controlling Office)		12. REPORT DATE August 76
17. DISTRIBUTION STATEMENT (of this Report) Approved for Public Release; Distribution Unlimited.		13. NUMBER OF PAGES 109
18. SUPPLEMENTARY NOTES		15. SECURITY CLASS. (of this report) UNCLASSIFIED
19. KEY WORDS (Continue on reverse side if necessary and identify by block number) Gas turbine testing, digital controls, propulsion controls, F-111, TF30, flight testing, integrated control		15a. DECLASSIFICATION/DOWNGRADING SCHEDULE
20. ABSTRACT The IPCS program proved that the operational capability of aircraft can be expanded by use of integrated propulsion controls. The techniques employed to achieve this improved performance include (1) early planning for integration, (2) early involvement of all concerned parties, and (3) freer communication, down to the working engineer level, than is considered common. Proper use and management of these three items constitutes the IPCS methodology. The goal of the Methodology document is to provide assistance in establishing the philosophy and direction that will minimize program risk and cost.		

UNCLASSIFIED

SECURITY CLASSIFICATION OF THIS PAGE (When Data Entered)

059 610

act

CONTENTS

<u>SECTION</u>	<u>PAGE</u>
ILLUSTRATIONS	4
TABLES	5
NOMENCLATURE	6
1.0 INTRODUCTION	9
1.1 PURPOSE AND SCOPE OF METHODOLOGY DOCUMENT	10
1.2 OVERVIEW OF VOLUME IV	10
1.2.1 Program Management	11
1.2.2 Development of System Requirements	11
1.2.3 Control Mode Design	11
1.2.4 Software Development	12
1.2.5 Hardware Development	12
1.2.6 System Integration and Test	12
2.0 PROGRAM MANAGEMENT	14
2.1 PLANNING	14
2.1.1 Time Line	14
2.1.2 Resources	18
2.2 ASSIGNMENT OF RESPONSIBILITIES	18
2.2.1 Company Relationships	18
2.2.2 Integrating Contractor	18
2.2.3 Division by Product Lines	18
2.2.4 Division by Technology	20
2.3 COMMUNICATION	20
2.3.1 Protection of Proprietary Information	20
2.3.2 System Definition and Configuration Control	23
2.3.3 Costs and Schedules	23
2.3.4 Informal Documentation	23
2.3.4.1 Coordination Memos	23
2.3.4.2 Telephone Communication	23
3.0 DEVELOPMENT OF REQUIREMENTS	24
3.1 PLANT DEFINITION DATA	24
3.1.1 Airframe Definition	25
3.1.2 Engine Definition	25
3.1.3 Electronic Interface Definition	28
3.2 PERFORMANCE - STABILITY TRADES	28
3.3 BASELINE CONTROL ALGORITHM	35
3.3.1 The Integrated Control Algorithm	36
3.3.2 Specialized Integrated Control Loops	37
3.3.2.1 Buzz Detection and Suppression	37
3.3.2.2 Real-Time Distortion Measurement	37
3.3.2.3 In-flight Airflow Optimization	37
3.3.2.4 Anticipation Signals	39
3.4 COMPONENT REQUIREMENTS	40
3.4.1 Propulsion System Components	40
3.4.2 Controller Requirements	42
3.4.2.1 Control Algorithms to be Implemented	42
3.4.2.2 Functional Description	44
3.4.2.3 Environment	44
3.4.2.4 Interfaces	44
3.4.2.5 Installations	46
3.4.2.6 Software	46
3.4.2.7 Pressure Capability	46

3.4.2.8	Power Conditioning	46
3.4.2.9	Input/Output	47
3.4.2.10	Built-In-Test Equipment (BITE)	47
3.4.2.11	Expansion Options and Flexibility Features	47
3.4.2.12	Signal Noise	47
3.5	RELIABILITY REQUIREMENTS	49
3.5.1	Purpose and Scope	49
3.5.2	Reliability Tasks	50
3.5.2.1	Reliability Program Plan	50
3.5.2.2	Subcontractor Control	50
3.5.2.3	In-House Reliability Program Requirements	50
3.5.2.4	Parts Program	50
3.5.2.5	Failure Modes and Effects Analysis (FMEA)	51
3.5.2.6	Numerical Reliability Requirements	51
3.5.2.7	Failure Reporting, Analysis, and Corrective Action	51
3.5.2.8	Design Reviews and Coordination Meetings	51
3.5.2.9	Project Organization	52
3.5.3	Assessment of the IPCS Reliability Program	52
3.5.4	Engine Reliability Requirements	52
3.5.5	Electronic Reliability Requirements	52
3.6	QUALITY ASSURANCE PROGRAM PLANNING	54
4.0	CONTROL MODE DESIGN	55
4.1	THE ANALYTICAL DESIGN TEAM	55
4.2	ANALYTICAL TOOLS	56
4.2.1	Digital Simulation	56
4.2.1.1	Digital Engine Simulation	57
4.2.1.2	Inlet Simulation	59
4.2.1.3	Digital Simulation Configuration	60
4.2.1.4	Field Deck Procedure and Alternatives	62
4.2.2	Hybrid Simulation	63
4.2.2.1	Use of Hybrid Simulations for Propulsion Control Development	63
4.2.2.2	Real Time Plant Simulation (RTPS) Recommendations	66
4.2.3	Stability Models	67
4.2.3.1	Extraction of Linear State Models	67
4.2.3.2	Transfer Function Generation Technique	69
4.2.3.3	Selecting the State Variables	70
4.2.3.4	Classical Operations on Linear Models	70
4.2.4	Application of Optimal Control Theory	71
4.2.4.1	Non-Linear Trajectory Optimization	72
4.2.4.2	Linear Quadratic Synthesis	72
5.0	SOFTWARE DEVELOPMENT	73
5.1	DEVELOPMENT PROCESS	73
5.2	SOFTWARE CONFIGURATION CONTROL	74
5.3	DOCUMENTATION OF REQUIREMENTS	74
5.4	RESOURCE UTILIZATION	75
5.4.1	Memory Size and Process Time	75
5.4.2	Word Length	75
5.5	SOFTWARE TESTING	76
5.6	FIELD SUPPORT	76
5.7	SOFTWARE DEVELOPMENT FOR ROM	77
6.0	HARDWARE DEVELOPMENT	78

6.1	ENGINE RELATED COMPONENTS	78
6.1.1	Transducer Selection	78
6.1.2	Gas Path Probes	79
6.1.3	Output Interfaces	80
6.2	INLET AND AIRFRAME RELATED COMPONENTS	80
6.2.1	Manufacturing Technique and Procedures	80
6.2.2	Modification of Aircraft Structure	80
6.2.3	Wiring	80
6.3	CONTROLLER DEVELOPMENT	81
6.3.1	System Studies and Recommendations	81
6.3.1.1	On vs Off Engine Mounting of Electronics	81
6.3.1.2	Power Requirements	82
6.3.1.3	Back-up System, Fail Safe, Fail Operational, Redundancy	82
6.3.1.4	Mechanical Design	83
6.3.1.5	Testability, Maintainability, Dispatchability	83
6.3.1.6	Interface to Other Systems	83
6.3.1.7	Computer Configuration	84
6.3.1.8	Memory Configuration	84
6.3.1.9	Transducer and Actuator Interface Requirements	85
6.3.1.10	Input/Output (I/O) Design	88
6.3.1.11	Software	88
6.3.1.12	Cabling	92
6.3.2	Controller Design, Fabrication, and Test	92
6.4	FLIGHT ASSURANCE TESTING	92
6.4.1	Flight Assurance Testing (FAT) of Engine Related Components	92
6.4.2	Flight Assurance Testing of Electronic Equipment	93
6.4.3	Flight Assurance Testing of Airframe-Mounted Equipment	94
6.5	SHOCK MOUNTING OF EQUIPMENT	96
6.6	SPARES PHILOSOPHY	96
7.0	SYSTEM INTEGRATION AND TEST	98
7.1	INTEGRATION PHILOSOPHY - THE STEP-BY-STEP APPROACH	98
7.2	TEST REQUIREMENTS	98
7.2.1	Engine and Fuel System Test Requirements	100
7.2.2	Inlet Test Requirements	100
7.2.2.1	Sensing Inlet Control Signals	100
7.2.2.2	System-Level Tests of Inlet Control Laws	101
7.3	TEST TIMING	101
7.4	TEST DATA	102
7.4.1	Instrumentation	104
7.4.2	Data Recording and Processing	105
8.0	REFERENCES	109

Illustrations

Figure		Page
1.1-1	Integrated Propulsion Control System Demonstrator Program	10
2.1-1	Demonstrator Program Milestone Time Line	15
2.1-2	Timing and Decision Points to Contract Item Specification	16
2.1-3	Demonstrator Program Flow Chart	17
2.2-1	Contractor Relationships	19
2.2-2	Analytical Control Design Plan	21
2.3-1	Document Tree	22
2.3-2	IPCS Coordination Memo Form	22
3.1-1	Influence of Engine Definition on Control Requirements	26
3.1-2	Example System Interconnections	26
3.1-3	Example Packaging Diagram	32
3.1-4	Example Electronics Block Diagram	33
3.3-1	Gas Generator Control Loop	38
3.3-2	Airflow Trade Study	39
3.3-3	Anticipation Signal Used in IPCS Inlet Control Loop	40
3.4-1	Information Flow Diagram	41
3.4-2	Shock Probe Transducer Temperature	42
3.4-3	Functional Block Diagram	43
3.4-4	Implementation Diagram	45
3.4-5	DPCU Start-Up Flow Diagram	48
4.2-1	Estimated Engine Performance	58
4.2-2	Comparison of Baseline Engine Data to Engine Simulation	58
4.2-3	Digital Propulsion Simulation Configuration	61
4.2-4	Sample Rate Studies	64
4.2-5	Real-Time Plant Simulation Configuration	68
6.3-1	Electronic Signal Processing of Pressure Transducers	86
6.3-2	Electronic Signal Processing for Position Transducers	86
6.3-3	Electronic Conversion for Position Outputs	87
6.3-4	Recommended Input Electronics Configuration	87
6.3-5	Timing Control of Input Electronics	89
6.3-6	Scratch Pad Memory Timing Sequence (Partial)	90
6.3-7	Input/Output Electronics 128 Word Address Counter	91
6.3-8	Recommended Output Electronics Configuration	91
6.4-1	Vibration Input to DPCU Box	95
7.1-1	Step-by-Step Integration and Test	99
7.3-1	Configuration Schedule	103
7.4-1	Data Handling Scheme	106
7.4-2	On-Board Data Recording	106
7.4-3	Data Processing Package	107
7.4-4	Typical PDP11 Machine Plot	107

Tables

Table		Page
3.1-1	Aircraft and Mission Constraints	25
3.1-2	Airframe - Propulsion Interaction	25
3.1-3	Sample Input Signal Table	29
3.1-4	Sample Output Signal Table	30
3.1-5	Sample Preliminary Design Requirements for an Electronic Controller	31
3.2-1	Inlet Disturbances	35
3.5-1	IPCS Reliability Program Assessment	53
4.2-1	Trades in Logistics of Digital Simulation	63

IPCS NOMENCLATURE

A/B	Afterburner
ABC1-ABC8	Afterburner Control Scheduled Functions in BOMDIG
Aj	Nozzle Area
A/D	Analog-to-Digital
ATP	Acceptance Test Procedure
BITE	Built In Test Equipment
BLFT	Baseline Flight Test
BOM	Bill-of-Materials
BOMDIG	Bill-of-Material Digital Control
CADC	Central Air Data Computer
CCU	Computer Control Unit
CDR	Critical Design Review
CFE	Contractor Furnished Equipment
CLBT	Closed-Loop Bench Test
CMU	Computer Monitor Unit
CPC	Computer Program Component
CPCEI	Computer Program Contract End Item
CPU	Central Processor Unit
D/A	Digital-to-Analog
dB	Decibel
DCS	Digital Computer System
DCU	Digital Computer Unit
DEM	Diffuser Exit Mach Number
DFRC	Dryden Flight Research Center
DIB	Discrete Input Buffers
DIO	Direct Input/Output Channel
DMA	Direct Memory Access Channel
DOB	Discrete Output Buffers
DPCU	Digital Propulsion Control Unit
DS	Design Specifications
ECS	Environmental Control System
EIB	Engine Interface Box
ENC	Exhaust Nozzle Control
ENC1-ENC8	Exhaust Nozzle Scheduled Control Functions in BOMDIG
EPR	Engine Pressure Ratio
EX	Excitation
FAT	Flight Assurance Test
FBCANG	Feedback Cam Angle
FMEA	Failure Mode & Effect Analysis
FMECA	Failure Mode, Effect, and Criticality Analysis
GFE	Government Furnished Equipment
GSE	Ground Support Equipment
HPC	High Pressure Compressor
HSPT	High Speed Paper Tape Punch & Reader
HMC	Hydromechanical Control
Hz	Hertz (= cycles per second)
I.C.	Initial Condition
ICD	Interface Control Document
IFU	Interface unit
I/O	Input/Output
KD	Distortion Index
LLMUX	Low Level Multiplexer
LM	Local Mach Number
LPC	Low Pressure Compressor
LRD	Lamp and Relay Drivers
LVDT	Linear Variable Differential Transformer

MFC	Main Fuel Control
MFC1-MFC7	Scheduled Functions in the BOM fuel Control, Represented by Tables or Polynominal Curve Fits in BOMDIG
MN	Airplane Mach Number
MSB	Most Significant Bit
MTBF	Mean Time Between Failures
MUX	Multiplex or Multiplexer
NSP	Non Standard Part
N1	Low Pressure Rotor Speed, PRM
N2	High Pressure Rotor Speed, RPM
OCV	Oscillator Controlled Voltage Circuits Demodulators
P	Pressure, See Illustration next page for Station Designations
Pb	Burner static pressure
PC	Programmable Clock
P/C	Printed Circuit
PCM	Pulse Code Modulation
PDR	Preliminary Design Review
PIL	Priority Interrupt Lines
PLA	Power Lever Angle
PLM	Local-Mach Total Pressure Signal
P/N	Part Number
POT	Potentiometer
PPH	Pounds Per Hour
PPS	Pounds Per Second
PRBC	Pressure Ratio Bleed Control (12th Stage Bleed)
PRI	Power Recovery Interrupt
PSLM	Local-Mach Static Pressure Signal
PSU	Power Supply Unit
RAM	Random Access Memory
RFD	Recycling Frequency-to-Digital Converters
RMS	Root Mean Square
ROM	Read Only Memory
RNI	Reynolds Number Index
RSS	Root Sum Square
RTC	Real Time Clock
RTD	Recycling Time-to-Digital Converters
SFCO	Software Field Change Order
S&H	Sample and Hold
SIA	Simulation Interface Adapter
SLS	Sea Level Static
SMD	Stepping Motor Drivers
SMITE	P&WA Technique for Iterative Solutions in Digital Simulation Program
S/N	Serial No.
SOAPP	P&WA Modular Program Assembly Procedure
SOD	Solenoid Drivers
STE	Special Test Equipment
T	Temperature
T/C	Thermocouple
TIGT	Turbine Inlet Gas Temperature
TSU	Test Set Unit
TTY	Teletype
VCO	Voltage Controlled Oscillator
Vex	Sensor Excitation Voltage
Vo	Sensor Output Voltage
Wa	Airflow Rate, lb/hour
WAR2	Corrected Air Flow Rate at Station 2
Wf	Fuel Flow Rate, Gas Generator, lb./hr.
WFG	Commanded Fuel Flow Rate, Gas Generator
WFZ1	Commanded Afterburner Fuel Flow, ith Zone, i=1,..., 5
XAJP	Resolver Angle on Nozzle Position Feedback
XAJV	Nozzle Control Pilot Valve Position
XCON	Cone Actuator Position
XOO	Afterburner Control Power Piston Position
XSPK (XORLS)	Spike Position (normalized spike position)

A suffix "S" indicates a sensed variable .

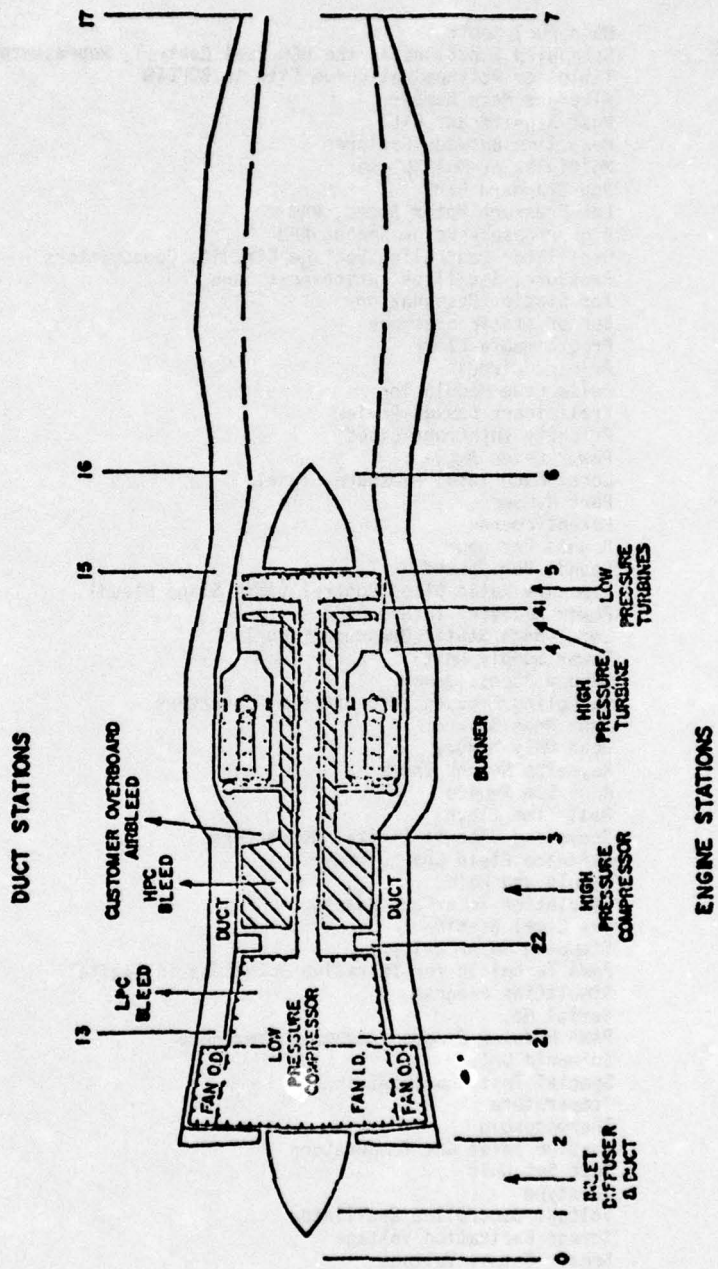

SUMMARY

The IPCS program has proven that considerably higher levels of flight system performance can be obtained by using a highly integrated propulsion system control. The techniques employed to achieve this improved performance go far beyond the use of such advancing technology as digital electronics or control mode analysis. They include (1) early planning for integration, (2) early involvement of all concerned parties, and (3) freer communication between all concerned parties, down to the working engineer level, than is considered common in weapons system programs. Proper use and management of these three items constitutes the IPCS methodology. The goal of the Methodology document is to provide assistance in establishing the philosophy and direction that will minimize program risk and cost.

Planning is the first task that must be addressed jointly by program participants. A time line showing a sequence of 64 key events is provided as a guide. Division of responsibilities should be negotiated within contractual constraints and documented in proposals to the customer. This division should reflect the resources that each organization can bring to bear. In many cases the resources are owned by the government; availability and possible use of these facilities should be explored in depth.

One contractor must have responsibility for making overall system studies and decisions. If the customer elects to retain this responsibility, he should be prepared for substantial involvement with the contractors in all aspects of their work; technical, contractual, and financial.

The development of requirements is a term applied to those activities that lead to a detailed set of preliminary hardware component and subsystem requirements and software requirements. These activities include much of the preliminary design and many system trade studies. Check lists and time-phased decisions are identified to the intercompany design team. The development of requirements is an iterative process that benefits from the free exchange of information.

A compendium of engineering practice that was successfully applied in the IPCS program is provided in the areas of hardware and software development and system integration and test. Recommendations in these areas reflect the IPCS philosophy of early planning, involvement of all parties, and free communication.

1.0 INTRODUCTION

The IPCS program has proven that considerably higher levels of flight system performance can be obtained by utilizing a highly integrated propulsion system control.

The techniques employed to achieve this improved performance go far beyond the use of such advancing technology as digital electronics or control mode analysis. They include: 1) Early planning for integration; 2) Early involvement of all concerned parties; 3) Freer communication between all concerned parties than is considered common in weapons system programs.

Proper use and management of these three items constitutes the IPCS methodology.

1.1 PURPOSE AND SCOPE OF METHODOLOGY DOCUMENT

The historical trend of aircraft controls development has been toward greater functional integration to maximize aircraft mission capability. This trend is expected to continue as analytical techniques are refined and flightworthy digital electronic hardware becomes more readily available.

The planning, organization, and control of the program to develop an integrated control system, which requires the crossing of both corporate and technical boundaries, imposes a heavy burden upon the program management. This, Volume IV of the IPCS final report, documents the joint experience, conclusion, and recommendations of the program participants relative to the chronology, principles, and procedures to be used in the development of an integrated propulsion control system of the future, as they would apply it.

The secondary purpose of this document is to provide guidance to the development process itself. Therefore, we have given strong emphasis to those activities that take place very early in the program.

We have described a successful methodology that can be applied in the development of an integrated propulsion control system for a high performance aircraft of the future. It is assumed that a new engine will be developed for this aircraft and that this engine and the inlet will be controlled by a digital electronic computer supported by appropriate electronic, electrohydraulic, and electromechanical devices. The controls development program activities treated in this document are summarized in Figure 1.1-1.

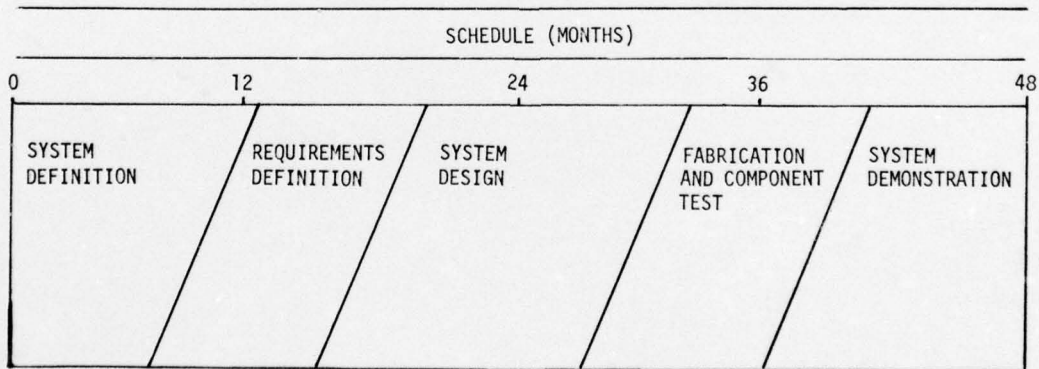

Figure 1.1-1 Integrated Propulsion Control System Demonstrator Program

Although the IPCS program was highly successful, it was a technology demonstration program, limited in scope, and greatly constrained by the pre-existence of the engine and aircraft. It is necessary to extrapolate IPCS experience in the context of subsequent and anticipated developments in order to treat a flight system probably larger in scope and subjected to other constraints.

1.2 OVERVIEW OF VOLUME IV

The primary usefulness of this document will occur in the early stages of the development program, when many important decisions must be made and the supporting technical staffs may not be fully organized. Our goal is to provide assistance in establishing the philosophy and direction that will minimize program risk and cost.

Specific areas treated herein are:

- Program management
- Development of system requirements
- Control mode design
- Software development
- Hardware development
- System integration and testing

We have attempted to identify the most important data, trades, and decisions that are required in each of these areas, and to provide guidance on the approach to finding the data and making the trades and the decisions.

1.2.1 Program Management

The topics of planning, communication, assignment of responsibility, and contractor relationships are covered in the Program Management section.

Planning is the first crucial task that must be performed jointly by the organizations contemplating the system-development exercise. It is essential that all the participants become involved in the development of a detailed time-phased flow diagram that identifies the time frame and the organization responsible for each subtask. Such a diagram is also useful in estimating the resources and information required to complete each task.

The assignment of responsibility to each contractor team member should be negotiated when the program is in the planning stage. These agreements should be documented in proposals to the customer and should be reflected in the work statements of the several contracts when they are let, if an associate contractor relationship is used in preference to the prime-sub arrangement.

Free interchange of information at the working engineer level was a basic rule that proved to be invaluable to the IPCS program. Discipline is important, but it is essential that it is not restrictive. This interchange will be more and more important as the degree of integration increases. The subsystem designer must have a good comprehension of the overall system.

1.2.2 Development of System Requirements

The "development of requirements" is a term applied to those activities that lead to a detailed set of preliminary hardware and software requirements. The outputs of the activities discussed under this heading are the following:

- A baseline controller configuration
- Definition of sensors and actuators required for controller implementation
- Electronic and physical interface definition
- Computer processor capability requirements
- Reliability and safety requirements
- Power requirements
- Environmental control and/or tolerance requirements

The development of component requirements is discussed in Section 3.3. Component requirements can be established only after the plant has been defined and the basic control algorithm has been designed. This lends urgency to those activities because detailed hardware, software, and control mode design cannot proceed until component requirements are defined. In addition the maximum possible lead time should be provided for component development and/or procurement.

Reliability requirements, Section 3.5, are a subset of the component requirements but are listed separately because of the specialized skills needed to develop them.

The development of requirements is an iterative process that benefits from the free exchange of information. Initial requirements estimates must be examined and updated as information becomes available.

1.2.3 Control Mode Design

Control mode design bridges the gap between the baseline design developed per paragraph 3.3 and the detailed definition of control modes required for physical implementation of the system. The following results are achieved in the process:

- Confirmation of the baseline control algorithm
- Development of logic networks
- Selection of gains, setpoints, and compensation
- Corroboration of component accuracy and frequency response requirements
- Development of failure detection and back-up modes

An analytical design team composed of working level personnel from the airframe, control, and engine companies should be established to perform the control mode design. Their fundamental design tool will be a non-linear digital dynamic simulation of the propulsion system and relevant portions of the airframe. A hybrid simulation used for specialized studies and software checkout and linear models used for loop design are derived from the digital simulation. The rapidly developing science of optimal controls should be explored for loop design.

1.2.4 Software Development

Conventional software development techniques were applied successfully during the IPCS program. It was concluded that verification testing should be done with the operational hardware and with the control loop closed by a real-time plant simulation. Field support during ground testing should include at least one software engineer to support test shift operations and one experienced individual whose primary responsibility is to design software modifications and maintain documentation.

1.2.5 Hardware Development

Hardware development covers the specification, design, procurement or fabrication, and testing of components that meet the requirements discussed in paragraph 1.2.2. It is commonly found that the components needed to meet specific requirements are unavailable, impossible with existing technology, or more expensive than anticipated. The requirements must be reassessed and the options weighed. Hopefully the requirements can be relaxed. Otherwise the penalty must be assumed. If this is unfeasible it may be necessary to redesign the control mode to eliminate the offending requirement. A program to generate new component technology should be attempted only as a last resort.

1.2.6 System Integration and Test

We strongly support the step-by-step approach to system integration and testing. Interface tests should be initiated by the controls manufacturer as soon as the hardware and software components become available. Final pre-delivery checkout of software should be performed on the actual control computer with its interface unit, using a real-time simulation to close the loop.

The IPCS fuel bench test procedure is sound and is adaptable to other programs. In addition, a closed-loop wind-tunnel test of a fully actuated inlet model is recommended, particularly if the inlet operates in a mixed-compression mode. Sea-level-static testing, followed by altitude testing of the demonstrator engine is recommended; initial tests would be run using a bell-mouth inlet. The introduction of a boiler-plate version of the flight inlet during the sea-level test program is desirable, particularly if the inlet is actuated during ground or low speed flight operation.

It is recommended that a data recording package be designed for use in ground and flight tests, together with a mobile data processing van that is moved from facility to facility during the entire test program. This approach will provide rapid data turnaround through the use of an on-site dedicated data processing facility and eliminate the requirement for interfacing with the facility data processing systems.

One of the conclusions drawn from the program is that the tests were too closely spaced on the schedule; there was not enough time between the tests to absorb the results. Another conclusion was that control mode development would be facilitated by a real-time plant simulation at the test site to close the control loops for software checkout.

2.0 PROGRAM MANAGEMENT

Development of an integrated control system requires adaptation of management disciplines to the special situation in which equipment built by one contractor will operate under the influence of a controller designed and built by another contractor to a set of requirements established by a contractor team. Subjects which must be given special consideration are:

- Planning
- Resources
- Responsibility
- Communication

The main objective of the management effort is to ensure that available resources are judiciously applied to achieve the end objective most effectively. Existing corporate organizations generally provide the discipline and structure which are necessary for effective control, but modifications to commonly accepted practice may be needed for smooth running efficiency. The capabilities and resources of each of the contractors must be recognized and used. Duplication of effort must be avoided, and opportunities for redistribution of work outside of traditional responsibility boundaries must be taken when it is apparent that benefits in efficiency or productivity will result.

2.1 PLANNING

Careful planning is crucial to any program. It is particularly important in the development of an integrated system which depends upon the interaction of several contractors and agencies. Efficiency of operation depends upon distribution of tasks over the period of time available.

2.1.1 Time Line

A sequence of 64 events has been set down in the time line shown in Figure 2.1-1. Five overlapping major phases have been split out covering the period of time which starts with the identification of a system application, and ends with the selection of contractors to proceed with the development of the system prototype. The time line has been structured to fit an engine/supersonic-inlet integration program. If the program involved other integration aspects, e.g., a subsonic VSTOL program, it would be necessary to substitute different events.

The end point has been selected to correspond to the end points of the System Development Program shown in Figure 58 of reference 1, reproduced here as Figure 2.1-2. The five major phases are System Definition and Preliminary Design, Requirements, System Design, Fabrication and Component Test, and System Demonstration.

Analysis is not shown as a phase, since it is necessary to continue a comprehensive analysis for the duration of the development of the system.

Simulation, controls analysis, performance, test data reduction, must proceed at different levels of emphasis to support the design, build and test of the system. A program flow chart, which shows how the program functions flow is shown in Figure 2.1-3.

This initial scheme will obviously need to be converted to a more detailed multi-tier schedule, that will permit precise tracking of milestones which measure progress and accomplishments of the program.

2.1.2 Resources

It is not possible to define the scope of the program or the participation of the contractors without due concern for possession and scheduling of resources such as test facilities and computers.

Technological capability must also be examined, such as the design and manufacture of:

- Airframes
- Engines
- Control systems
- Electronics
- Software

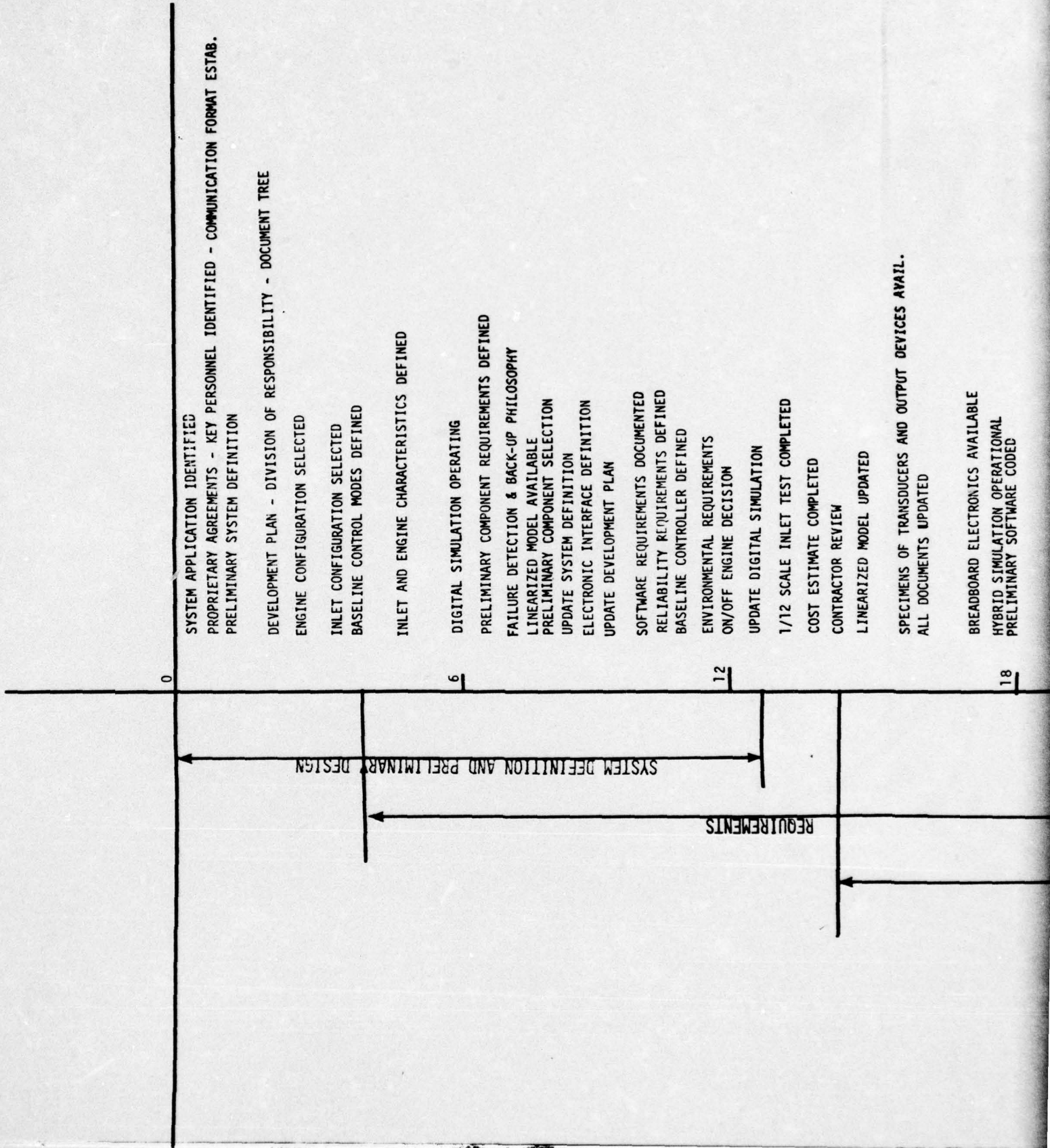

BASELINE CONTROLLER DEFINED

ENVIRONMENTAL REQUIREMENTS
ON/OFF ENGINE DECISION

UPDATE DIGITAL SIMULATION

1/12 SCALE INLET TEST COMPLETED

COST ESTIMATE COMPLETED

CONTRACTOR REVIEW

LINEARIZED MODEL UPDATED

SPECIMENS OF TRANSDUCERS AND OUTPUT DEVICES AVAIL.
ALL DOCUMENTS UPDATED

BREADBOARD ELECTRONICS AVAILABLE
HYBRID SIMULATION OPERATIONAL
PRELIMINARY SOFTWARE CODED

UPDATE DIGITAL SIMULATION

CLOSE LOOP ON BREADBOARD SYSTEM + REAL-TIME SIMULATION
RFQ FOR DEMONSTRATOR PROGRAM RELEASED

DOCUMENT ALL INTERCOMPANY AGREEMENTS
PROPOSAL SUBMITTED

UPDATE LINEAR MODELS

UPDATE REAL TIME SIMULATION

CONTRACTORS SELECTED FOR DEMONSTRATOR PROGRAM

UPDATE DEVELOPMENT PLAN

START FAB/PROCUREMENT OF MOBILE TEST DATA SYSTEM

UPDATE REQUIREMENTS

CUSTOMER REVIEW

START PROCUREMENT OF LONG-LEAD ITEMS

UPDATE DIGITAL SIMULATION

DESIGN OF DEMONSTRATOR SYSTEM COMPLETE

DESIGN REVIEW

START HARDWARE & SOFTWARE FABRICATION

12

18

24

30

REQUIREMENTS

SYSTEM DESIGN

ICATION AND COMPONENT TEST

2

START PROCUREMENT OF LONG-LEAD ITEMS

30

UPDATE DIGITAL SIMULATION

DESIGN OF DEMONSTRATOR SYSTEM COMPLETE

DESIGN REVIEW

START HARDWARE & SOFTWARE FABRICATION

FABRICATION AND COMPONENT TEST

36

PROTOTYPE RFQ RELEASED

CHECKOUT OF DATA SYSTEM COMPLETE

FIRST CONTROLLER AND SOFTWARE DELIVERED

START CLOSED - LOOP WIND TUNNEL TESTS; 1/6 SCALE ACTUATED MODEL

PROTOTYPE PROPOSAL SUBMITTED

BENCH TEST PLAN RELEASED

SECOND CONTROLLER DELIVERED

START FUEL BENCH TEST

42

CONTRACTORS SELECTED FOR PROTOTYPE PROGRAM

START PROTOTYPE DESIGN

DEMONSTRATOR ENGINE RUNS, SEA LEVEL STATIC

SOFTWARE UPDATED

DRAFT SYSTEM SPEC. RELEASED

SOFTWARE UPDATE

START ALTITUDE TEST OF DEMONSTRATOR ENGINE

SYSTEM SPECIFICATION RELEASED

48

15

SYSTEM DEMONSTRATION

Figure 2.1-1 Demonstrator Program Milestone Time Line

3

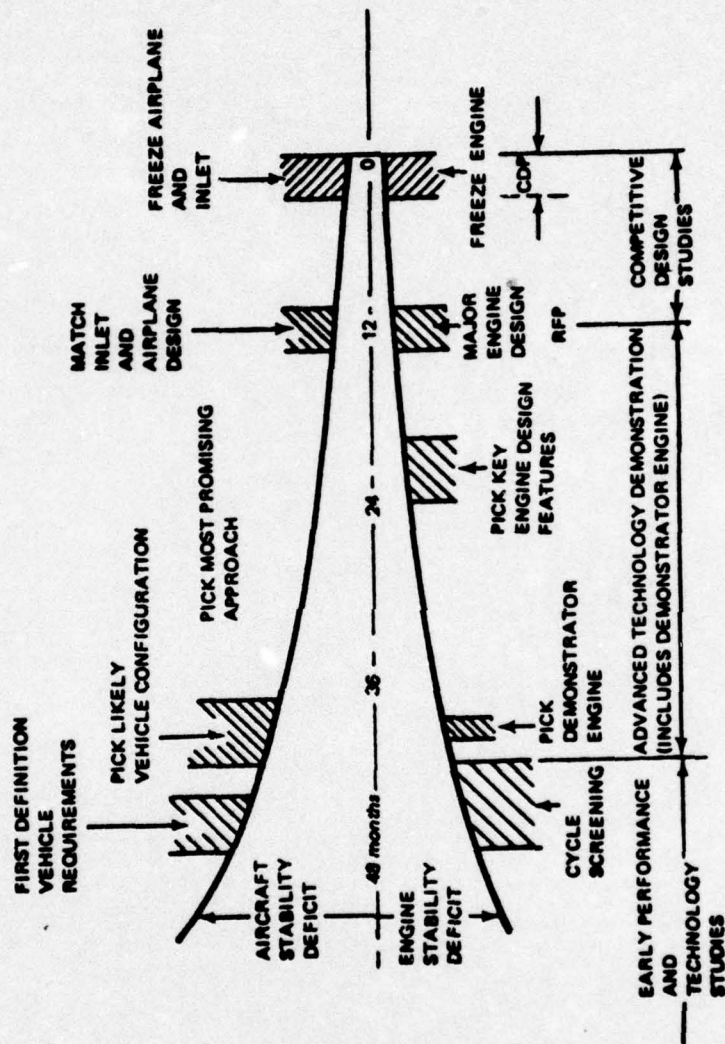

Figure 2.1-2 Timing and Decision Points to Contract Item Specification

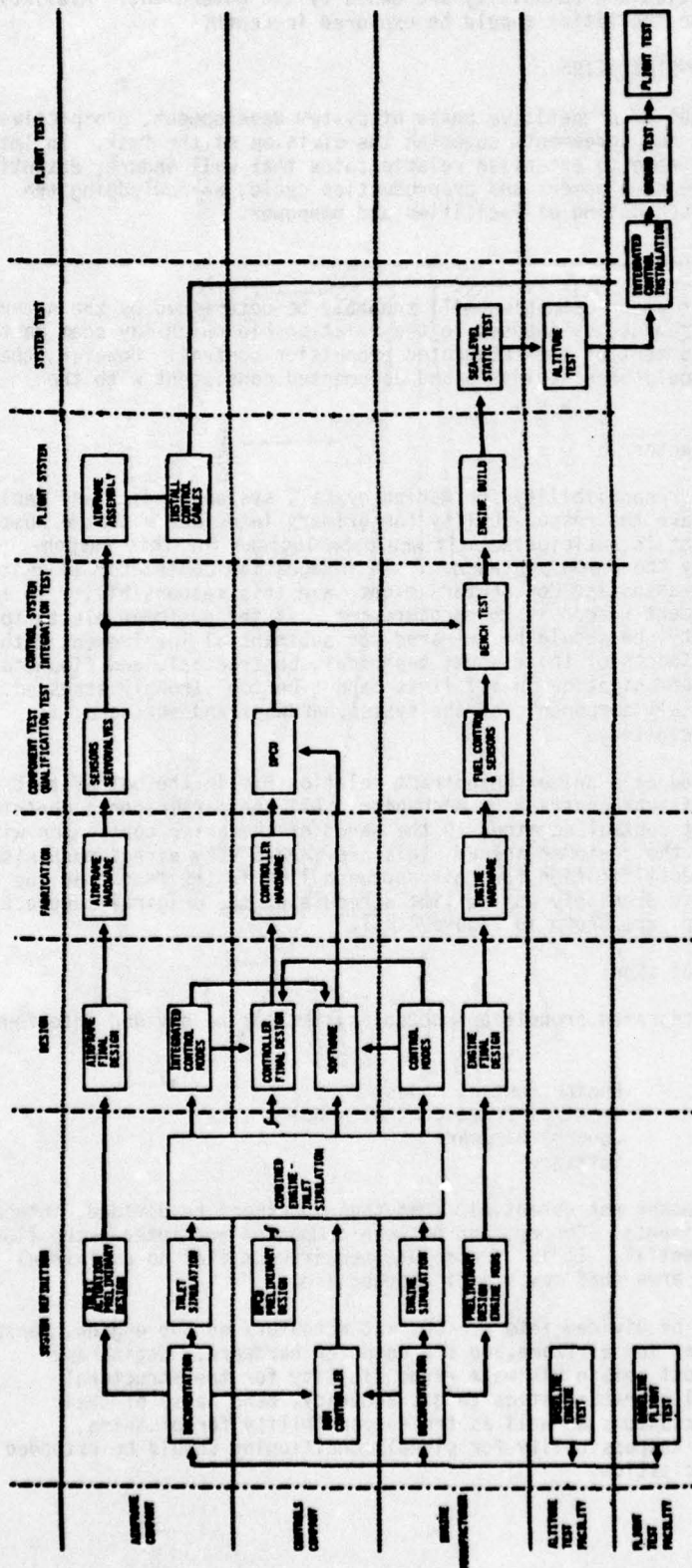

Figure 2.1-3 Demonstrator Program Flow Chart

In many cases the facilities and capability are owned by the government. Availability and possible use of these facilities should be explored in depth.

2.2 ASSIGNMENT OF RESPONSIBILITIES

During the pre-contractual or competitive phase of system development, prospective participants should work out agreements covering the division of the task. In interest of continuity it is desirable to establish relationships that will endure, essentially unchanged, throughout the development and preproduction cycle, acknowledging the phasing of the work and scheduling of facilities and manpower.

2.2.1 Company Relationships

Contractual relationships among companies will probably be determined by the nature of the anticipated procurement, as opposed to the relationship which may seem most attractive for the development of the integrated propulsion control. However, the working relationships should be established and documented consistent with the contractual constraints.

2.2.2 Integrating Contractor

One contractor must have responsibility for making overall system studies and decisions. This contractor should have the responsibility for primary interface with the customer. If a single prime contract is anticipated, it would be logical for this responsibility to be assumed by the prime contractor. An integration contractor is another possibility. One of the associate contractors might have this responsibility in the case of a typical government weapon system procurement. If the customer elects to retain this responsibility, he should be prepared for substantial involvement with the contractors in all aspects of their work; technical, contractual, and financial. The importance of open communication in all links cannot be too strongly stressed. Configuration control of all components of the system, hardware and software, is another important responsibility.

The IPCS program was based on a prime/subcontract relationship in the belief that it provided the most efficient contracting mechanism. All the participants contributed to program direction, but control remained in the hands of the prime contractor with direct responsibility to the customer agency. This provided a very direct mechanism for rapid decision making. Justification for this approach lies in the fact that the 3-year program was completed precisely on the time schedule of the original contract. The intercompany relationships are shown in Figure 2.2-1.

2.2.3 Division by Product Lines

The development of an integrated propulsion control system can be divided into four areas:

- Engine control modes
- Inlet/airframe control modes
- Control hardware
- Software

It would be natural, although not essential, that these packages be divided, intact, among the program participants. Cooperation between companies and inter-group flow of communication are essential. It is an absolute requirement that no unilateral decisions be made in one area that may impact another area.

The control hardware may be divided into sensors and actuators on the engine, sensors and actuators in the inlet and airframe, and the computer hardware. Engine and airframe manufacturers must retain ultimate responsibility for the structural integrity and operational characteristics (e.g., accuracy, band pass) of their respective sensors and actuators as well as the responsibility for plumbing, mounting brackets, etc. Responsibility for signal conditioning should be extended to include transducer excitation.

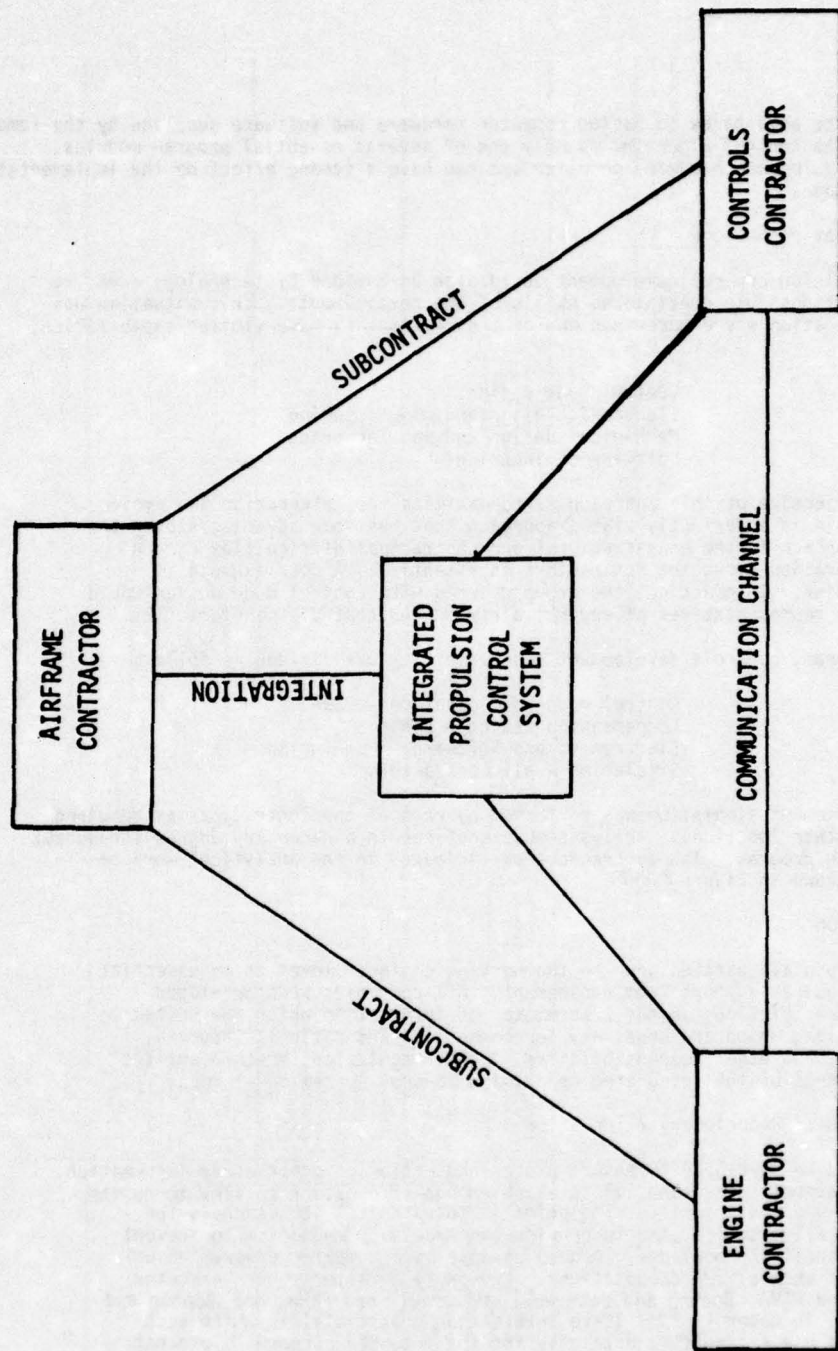

Figure 2.2-1 Contractor Relationships

There are definite advantages to having computer hardware and software supplied by the same organization. The control algorithm is only one of several essential program modules. Some of these modules are hardware peculiar and can have a strong effect on the implementation of the control modes.

2.2.4 Division by Technology

Integrated propulsion control development could also be divided by technology areas to take advantage of possible specialized skills of the participants. This situation has particular application where more than one of the contractors have similar capabilities, for example:

- Control mode design
- Electronic design and manufacturing
- Mechanical design and manufacturing
- Software engineering

The important objective of this approach is to maximize the integration and avoid duplication. This is a perfectly viable approach that has some advantages over the product line approach if the organizational and contractual difficulties can be overcome. Cooperation among the contractors is essential. A good example is control mode design. In practice, the group charged with control mode design would probably include representatives of engine, airframe and controls manufacturers.

In the IPCS program, controls development responsibility was divided as follows:

- Control mode configuration - P&WA
- Compensation Design - Boeing
- Electronics and Software - Honeywell
- Simulation - all contractors

Under this arrangement simulation was performed by each of the contractors as required to support the other functions. Analysis must continue to a necessary degree throughout all phases of the program. The contractors participated in the analytical work of the program as shown in Figure 2.2-2.

2.3 COMMUNICATION

Communication among all parties down to the working engineer level is an essential function that requires support from management. All companies have developed disciplines and restrictions on the transmittal of information which are suited to their own situation, which are necessary for commercial and national security, public relations, and other responsibilities. These regulations must be adapted to the special needs of the integrated propulsion control system development.

2.3.1 Protection of Proprietary Information

Agreements should be developed to ensure proper protection of proprietary information. Intercompany agreements are essential to allow enough information to flow to do the job efficiently and conveniently. The point is to establish the channels for communication of all material, and to provide the necessary mechanism to prevent improper use of specific knowledge. A good example is a computer program which may be capable of specialized computations. Two-party agreements were executed between Boeing and P&WA, Boeing and Honeywell, Honeywell and P&WA, and Boeing and General Dynamics, in order to facilitate information transmittal in which each company agreed to use transmitted data only for the intended purpose to protect it, and not to make any unauthorized use of it. In each case, the two companies made reciprocal agreements and defined the formalities to be observed.

2.3.2 System Definition and Configuration Control

The contractors must be able to depend upon being able to work from a consistent definition of the system at all times. It is thus essential to maintain a formal system of documentation which the technical participants can use without inconvenience. Such a system is outlined in Figure 2.3-1. Some of these documents are normal requirements in the formal documentation of the contract, others are not. The document control mechanism must be flexible and easily used in order to ensure that updates are made when needed. The documentation system is the key to effective configuration control.

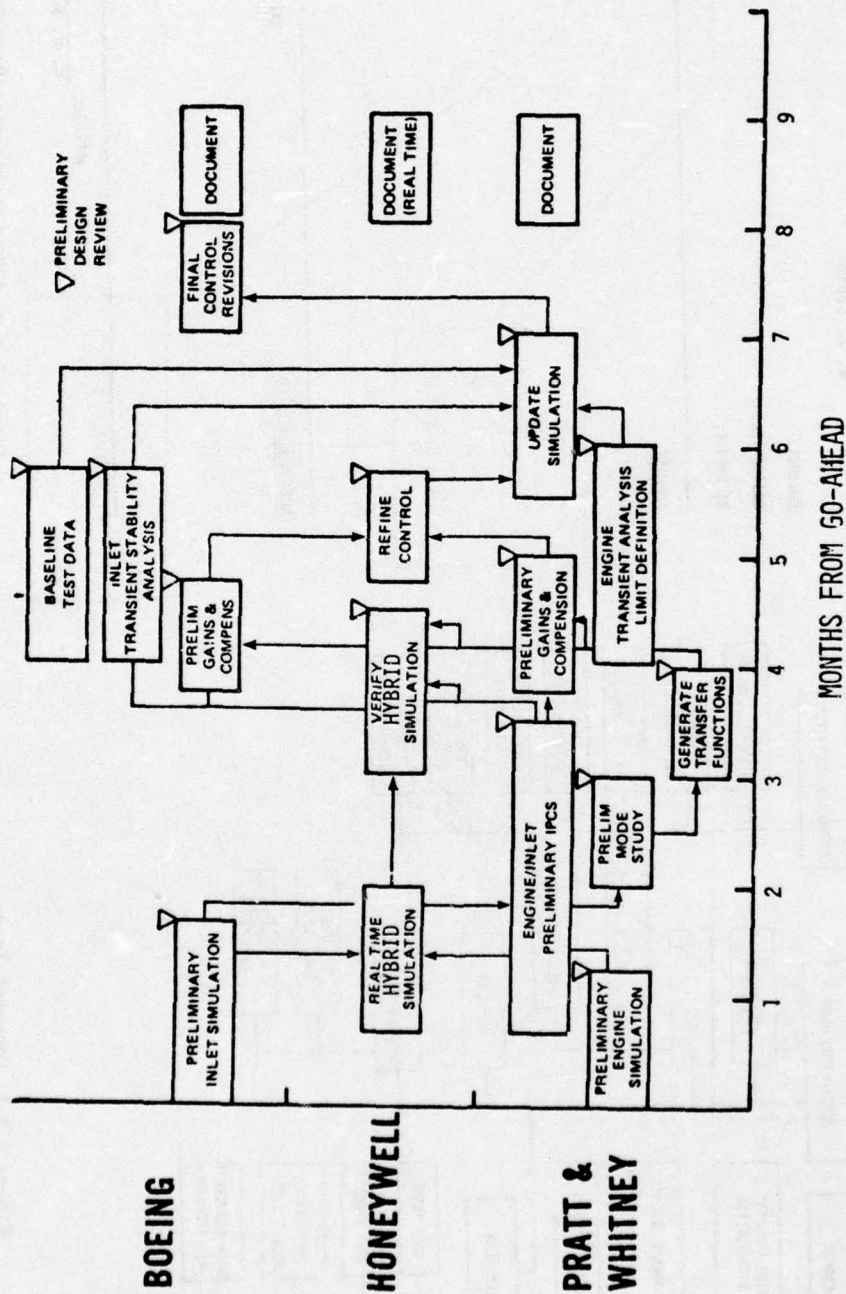

Figure 2.2-2 Analytical Control Design Plan

BOEING/HONEYWELL/PRAATT & WHITNEY
 INTEGRATED PROPULSION CONTROL SYSTEM

COORDINATION MEMO NO. _____ DATE _____

TO: E. G. Johnson
 G. J. Sevich

SUBJECT:

ORIGINATOR:

REFERENCE:

SUMMARY

ACTION REQUESTED

DATE

APPROVAL G. W. N. Lampard

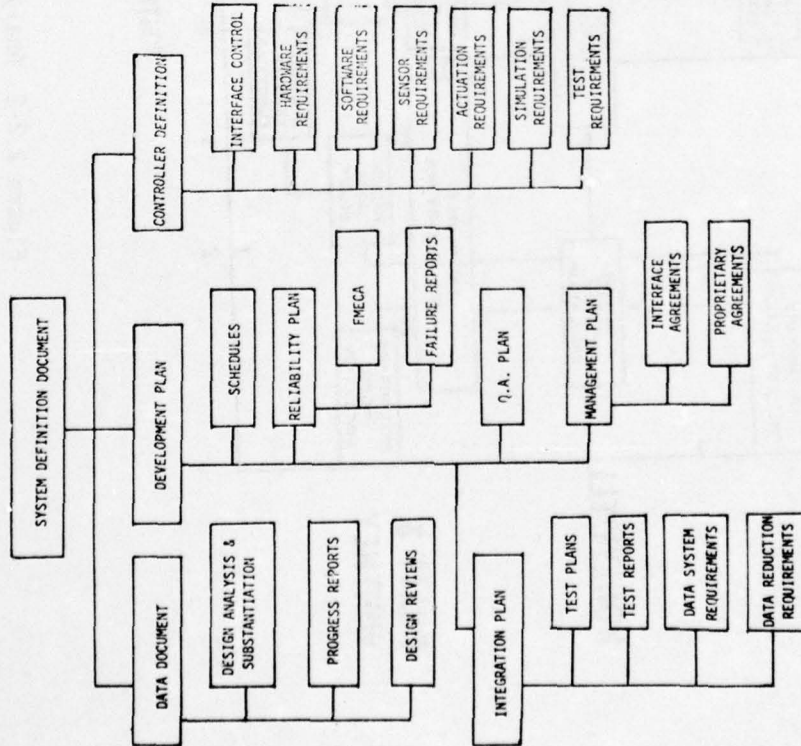

Figure 2.3-2 IPCS Coordination Memo Form

Figure 2.3-1 Document Tree

A configuration-controlled glossary of terms should also be provided in the Systems Definition document. Use of these terms should be required by all development areas to ensure compatibility.

2.3.3 Costs and Schedules

Formal and informal transmittal of cost and schedule data are essential for the program to be kept under control. Routine monthly transmittal of information is not adequate for precise control, and informal supporting communication agreements may have to be set up to provide cost control.

Visibility is necessary within a time frame to provide response which will control the costs. During periods of heavy expenditure rate, weekly updates of costs and schedules are probably necessary for effective intra-company, and inter-company control.

2.3.4 Informal Documentation

A means of rapid "semi formal" documentation is necessary so that information can be transmitted which is not subjected to the restrictions resulting from contractual formality. Users of such a system should understand that their messages do not possess contractual commitment, although, obviously this does not relieve the user from responsible use of the medium.

2.3.4.1 Coordination Memos

Written technical communications were handled with an effective "Coordination Memo" system, which was used to exchange data and to document telephone commitments when required. A simple format is important to encourage free use of this convenient system and it should be a vital part of any cooperative development program. The form used for IPCS coordination memos is shown in Figure 2.3-2. Each IPCS coord memo was sent by the originating contractor to both of the other major contractors on the program. This is considered an essential feature of open communication.

2.3.4.2 Telephone Communication

Use of direct verbal communication among team members is essential. Communication by telephone played a major role in the IPCS program. In order to permit a free exchange of technical information, each individual had to understand the overall program well enough to exercise sound judgment and make valid commitments. In addition, an efficient, internal telephone memorandum system was required to keep key personnel advised of the substance of the conversations. This technique proved effective for the small R&D effort, but the magnitude of a major development program could reduce this procedure to chaos unless discipline is practiced. In that case, limiting the interchange to one individual in each key discipline might be equally effective and should not be a management burden. As an alternative, it might be feasible to assign to each individual a counterpart in the other company(s) that he may contact freely.

A small effort to use commonly available facilities such as speaker phones, three party conference calls and facsimile machines can considerably enhance the rate at which problems are dealt with. Again it usually falls upon program managers to provide such facilities and encourage their use.

3.0 DEVELOPMENT OF REQUIREMENTS

The "development of requirements" is a term applied to those activities that lead to a detailed set of preliminary hardware component and subsystem requirements and software requirements. The major activities covered under this heading are the compilation of data, preliminary design of control modes, and trade studies. These activities should begin with the release of the Development Plan (see the time line in Figure 2.1-1) and should proceed concurrently with the preliminary design of the engine and airframe. Basically, they bridge the gap between the preliminary system definition and hardware and software design and procurement activities. The output of the activities discussed in this heading will be the following:

- A baseline controller configuration
- Definition of sensors and actuators required for control implementation
- Electronic and physical interface definition
- Computer processor capability requirements
- Reliability and safety requirements
- Power requirements
- Environmental control and/or tolerance requirements

These activities will last approximately a year. Considerable interaction between control and performance groups should occur during this period for two reasons: 1) To ensure that plants are controllable to the degree necessary to provide the performance levels being predicted by the performance group. 2) To ensure that performance/stability groups utilize the full range of flexibility offered by sophisticated controls. At the end of this time, a cost estimate will be possible and a contractor review should be conducted to evaluate the suitability of the baseline controller.

3.1 PLANT DEFINITION DATA

The paragraphs below define the major portion of the information about the plant-engine, inlet, and relevant portions of the airframe - that is required to perform the design and preliminary development of an integrated propulsion control system. In some cases not all the data are required for any one flight system but it is impossible to predict precisely which items may be safely eliminated from the list. Similarly it is impossible to define in advance the accuracy and detail required. Hence, the following urgent recommendations are made:

1. A document should be established at the preliminary definition stage of system development to provide the framework to assemble and disseminate the information described above. The initial release may be based upon technology program data, government specifications, requests for proposals, engineering estimates, etc. but it should be complete as possible. Sources of information should be clearly identified; it should be the user's responsibility to ensure that the data are accurate enough for his requirements.
2. Responsibility for compiling and updating the data document should be assigned to data administrators clearly identified within each company that is participating in the system development. These people should have unrestricted communication with their counterparts in other companies. Program managers within each company should ensure that their data administrators have the support and resources required to carry out their jobs.
3. Persons using the data document should communicate their requirements to the data administrator as well as transmitting in a timely manner all new information that they generate or comes into their possession. It is not recommended that persons needing information be prohibited from pursuing it on their own, but rather that all information be retained in a common, standard pool.
4. Data document updates should be scheduled at intervals compatible with the system development plan.

The paragraphs below address the information that should be included in the document.

3.1.1 Airframe Definition

The airframe definition referred to here covers all aspects that impact the propulsion controls; that is, a compilation of constraints and requirements that the propulsion system and its controller must satisfy in order for the aircraft to perform its intended functions. These include the aircraft and mission constraints, a description of the inlet, a definition of airframe - propulsion system interactions, and environmental considerations.

The aircraft mission definition includes the flight envelope, the point(s) in the flight envelope to which the aircraft is optimized, the design mission profile, the propulsion system response requirements, and aircraft constraints. Some of the relevant constraints are listed in Table 3.1-1.

There is considerable current interest in the use of the propulsion system to augment the aircraft lift and/or control forces. The concept is so new that it is impossible to define positively the data that will be required. However, some candidates are listed in Table 3.1-2.

Table 3.1-1 Aircraft and Mission Constraints

Maneuver Limits	Crew Size
Noise and Emission Limits	Ground Servicing Requirements
Safety Restrictions	Ships Power
Reliability Requirements	Operability
Noise Abatement	Thrust Vectoring
Boundary Layer Blowing	Customer Bleed
Flight Control Augmentation	Component Environment
Location of Engines	

Table 3.1-2 Airframe-Propulsion Interaction

Propulsion system drag characteristics
Inlet spillage drag
Bypass drag
Boundary-layer bleed drag
Aft-end drag - effect of variable nozzle, blow-in doors, etc.
Ingestion of hot gases
Effect of propulsion forces on aircraft stability and control
Effect of propulsion flowfield on aircraft lift, drag, stability, and control

3.1.2 Engine Definition

The typical engine development process starts with a set of mission requirements that serve as criteria for engine cycle and configuration studies. A controls observer in the cycle selection procedure would be most useful. Possible constraints in control implementation should be a factor during cycle selection to ensure that propulsion system goals are achievable.

These advanced studies eventually lead to selection of an optimum cycle and configuration, and it is then that sufficient information should be available to begin the control development process, as indicated in Figure 3.1-1. When the engine cycle and configuration are selected, the following information is generally known:

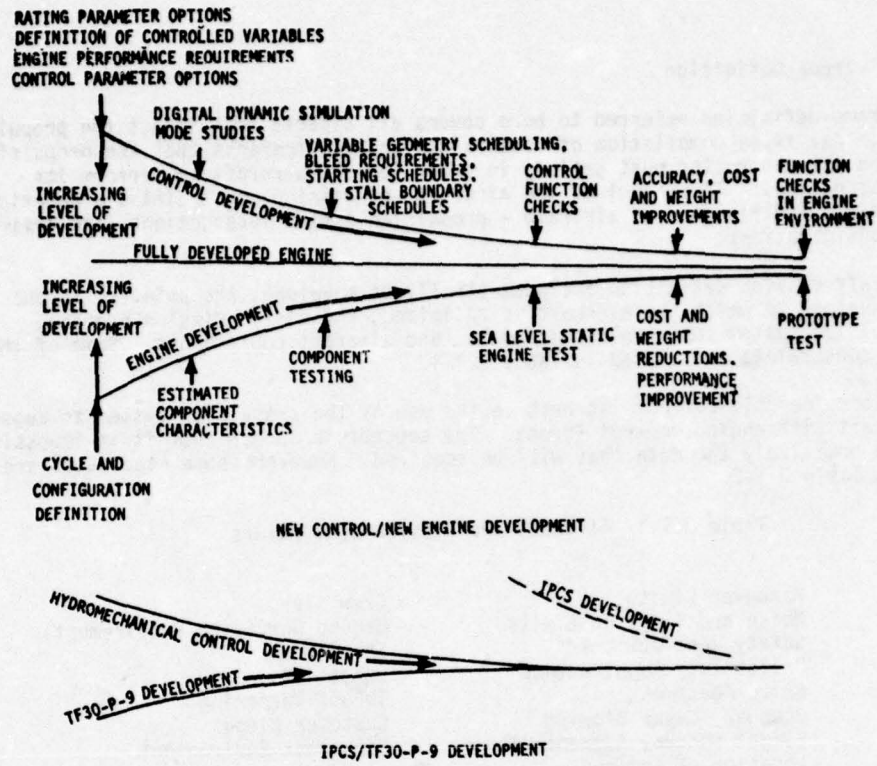

Figure 3.1-1 Influence of Engine Definition on Control Requirements

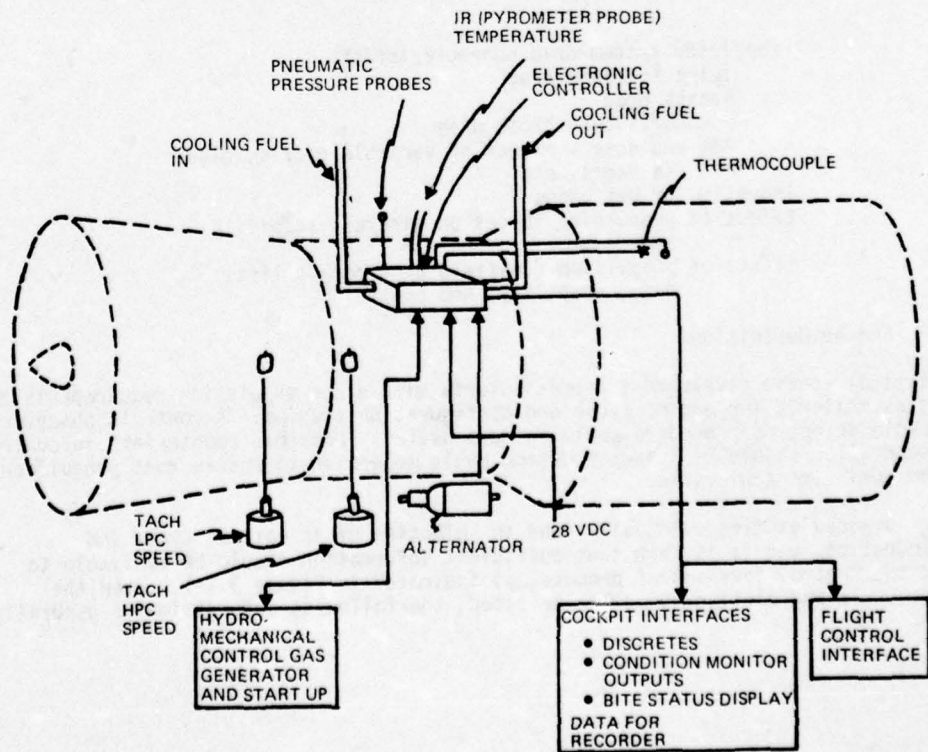

Figure 3.1-2 Example System Interconnections

Engine operational requirements (thrust, TSFC, weight, thrust response, range of operation, stability requirements and mechanical design limits).

Engine controlled variables (fuel flow, stator vane angle, nozzle area, turbine area, compressor bleeds).

Options for sensed variables (pressure ratios, corrected speeds, temperatures, Mach numbers, etc.)

Engine rating options (turbine discharge pressure ratio, turbine inlet temperature, low rotor speed, etc.).

Ranges of sensed variables.

This information is sufficient to begin control mode studies. In general each controlled variable will be used in an integrated manner to achieve overall propulsion system goals rather than as a fix for specific problems. Thus compressor bleeds are used to provide performance/stability trades in flight rather than just as a means of providing surge margin during starting.

Engine rating requirements such as turbine inlet temperature or corrected speed limits influence the selection of steady state governing parameters and sensor requirements.

In the early stages of engine development, a dynamic engine simulation (Section 4.1.1) is used to predict steady state and transient engine operation to evaluate control modes and generate schedules. The simulation includes estimated engine component characteristics that become better defined as development progresses through component rig testing. As the simulation is updated to incorporate component test results, the control studies are reviewed to ensure that the control operation meets all requirements. Typical component characteristics that influence control design are listed below.

Compressor stall boundaries for limiting transient fuel flow.

Inlet distortion tolerance characteristics and airflow range.

Burner lighting characteristics for fuel management during the starts.

Compressor bleed requirements for starting and stall protection.

Optimum afterburner fuel distribution for schedule development.

Turbine inlet temperature limits for limiting transient fuel flow

Rotor speed and burner pressure limits.

It is important that the influence of projected sensor and computational accuracy be included even during the preliminary computer studies to determine if the candidate control modes are feasible.

Refinements and modifications are made after the engine test, but these changes have a smaller effect on control design than the earlier phases of engine development.

The IPCS control development began after the TF30-P-9 engine was in service, and control requirements were well defined at the outset. A dynamic simulation was developed from component characteristics and refined until it closely approximated engine operation at sea level static and at altitude. New control modes were developed and schedules were generated to meet established control requirements with the aid of the simulation. A comparison of IPCS control and new control development in relation to engine development is shown in Figure 3.1-1.

3.1.3 Electronic Interface Definition

The electronic interface definition portion of the Plant Definition will be the result of the trade studies by the intercompany team as discussed at the beginning of this section. These experts will address themselves to developing the optimum baseline: sensor, actuator, power air-frame electronic interface, and to the adequate definition of these interfaces. The definition of interfaces will also include a baseline definition of the controller: installation, size, weight, power limitations, hydraulic interface and fuel/air cooling interface.

Tables 3.1-3 and 3.1-4 provide examples of I/O interface tables that provide the type of data required for the electronic interfaces. Tables 3.1-5 provides a table of requirements for the electronic controller. Figure 3.1-2, 3.1-3, and 3.1-4 show examples of a controller block diagram and pictorials of the mechanical configuration for the electronic controller. These tables and figures demonstrate the type of Electronic Interface Definition required to commence design of the electronic controller. Tables and figures similar to these were developed during the IPCS Program to establish an early definition of the plant and the electronic controller/plant interface requirements.

3.2 PERFORMANCE - STABILITY TRADES

The primary means of effecting flight system performance, once the basic airframe configuration and engine cycle have been selected, is in the hands of the various control groups. In the case of a moderately complex system such as the F-111/TF30 and future Variable Cycle Engine (VCE) concepts, the control has an extremely strong influence on performance. The basic goal is to maximize performance when destabilizing effects are small, such as during cruise, and to provide adequate stability during disturbances such as maneuvers or other transients. Since engine and airframe interactions affect both performance and stability, control integration is required to achieve this goal. The advent of relatively reliable digital computers has made practical the sensing and logic necessary to perform the trade in real time. This trade, made in flight, was the primary means used to improve the performance of the F-111/TF30 system on this program.

Control concepts to apply this capability include the following:

- Engine bleed only when near-instability exists as measured by some direct or indirect means. Engine thrust and fuel consumption during cruise should be improved.

- Direct control of afterburner fuel-air ratio and fan match to produce both performance and stability benefits while operating closer to the limits.

- Direct measurement of critical variables to control fuel flow during engine transients to improve transient times by operating closer to the compressor stability and turbine temperature limits.

- Inlet air bleed and geometry resets during measured disturbances.

To factor the control capabilities and limitations into the design process, control specialists must participate in the propulsion system design activity. Basic decisions at the propulsion component level, such as inlet sizing and compressor surge margin should be made with full visibility into control accuracy and response capabilities.

The performance benefit of additional variable geometry must be assessed with consideration for the impact on inlet, engine and control system cost, weight and reliability. The results of these objective trade studies will support the design decisions that must be made throughout the preliminary design of the propulsion system.

Table 3.1-3 Sample Input Signal Table

Parameter	Name	Range	Transducer	DECC Filtering	Conversion Accuracy Goal	Max Time Between Updates	Expected Cnvt Technique *
Temperature	T1 (Engine Inlet)	-55 to 205°C	Resistor, (R & Type-TBS)	16 Hz (TBS)	±0.25% (TBS)	20 ms (TBD)	Bridge and Buffer Amplifier (BABA) A/D, LL
Temperature	T2 (HP CMPR IN)	-20 to 320°C	Resistor, (R & Type-TBS)	16 Hz (TBS)	±0.25% (TBS)	20 ms (TBD)	BABA, A/D, LL
Temperature	T13 (Fan Out)	-20 to 320°C	Resistor, (R & Type-TBS)	16 Hz (TBS)	±0.25% (TBS)	20 ms (TBD)	BABA, A/D, LL
Temperature	T4-1 (HP/LP Turb Inlet)	-20 to 1485°C	Pt-Rh TC (Mv Range-TBS)	16 Hz (TBS)	±0.25% (TBS)	20 ms (TBD)	LL BUFF (G=170) A/D, LL
Temperature	TP (Transducer Package)	-54 to +100°C	Resistor, (R & Type-TBD)	16 Hz (TBS)	±0.25% (TBS)	20 ms (TBD)	(BABA), A/D, LL
Pressure	PT1A	0 - 50 psia	Bridge-SS (or Osc - TBD)	16 Hz (TBS)	±0.25% FS to 20% FS ±0.5% FS Beyond 80% FS (St. Line 20% to 80%)	20 ms (TBD)	A/D (or F/D - TBD), LL
Pressure	PT1B	0 - 50 psia	Bridge-SS (or Osc - TBD)	16 Hz (TBS)	±0.25% FS to 20% FS ±0.5% FS Beyond 80% FS (St. Line 20% to 80%)	20 ms (TBD)	A/D (or F/D - TBD), LL
Pressure	PT4-1A	0 - 100 psia	Bridge-SS (or Osc - TBD)	16 Hz (TBS)	±0.5% F.S.	20 ms (TBD)	A/D (or F/D - TBD), LL
Pressure	PT4-1B	0 - 100 psia	Bridge-SS (or Osc - TBD)	16 Hz (TBS)	±0.5% F.S.	20 ms (TBD)	A/D (or F/D - TBD), LL
Pressure	PT3A	0 - 400 psia	Bridge-SS (or Osc - TBD)	16 Hz (TBS)	±0.25% F.S.	20 ms (TBD)	A/D (or F/D - TBD), LL
Pressure	PT3B	0 - 400 psia	Bridge-SS (or Osc - TBD)	16 Hz (TBS)	±0.25% F.S.	20 ms (TBD)	A/D (or F/D - TBD), LL
Pressure	PT7	0 - 125 psia	Bridge-SS (or Osc - TBD)	16 Hz (TBS)	±0.25% FS to 20% FS ±0.5 to FS Beyond 80% FS (St. Line 20% to 80%)	20 ms (TBD)	A/D (or F/D - TBD), LL
Pressure	PT13	0 - 100 psia	Bridge-SS (or Osc - TBD)	16 Hz (TBS)	±0.25% FS to 20% FS ±0.5 to FS Beyond 80% FS (St. Line 20% to 80%)	20 ms (TBD)	A/D (or F/D - TBD), LL
Pressure	PT3 - PS3	0 - 40 psia	Bridge (or - TBD)	16 Hz (TBS)	±0.25% FS	20 ms (TBD)	A/D (or F/D - TBD), LL
Position	WFGS (Fuel MTRG Valve)	(TBS)	LVDT (5 KHz Ex)	32 Hz (TBS)	±0.25% (TBS)	5 ms (TBD)	5 KHz Ex, LVDT Demod, A/D, HL
Position	FIGVS (Fan INL Guide Vane)	(TBS)	LVDT (5 KHz Ex)	32 Hz (TBS)	±0.25% (TBS)	20 ms (TBD)	5 KHz Ex, LVDT Demod, A/D, HL
Position	CVGS (CMPR VAR GEO)	(TBS)	LVDT (5 KHz Ex)	32 Hz (TBS)	±0.25% (TBS)	20 ms (TBD)	5 KHz Ex, LVDT Demod, A/D, HL
Position	HPTVS (H P TURB Vane)	(TBS)	LVDT (5 KHz Ex)	32 Hz (TBS)	±0.25% (TBS)	20 ms (TBD)	5 KHz Ex, LVDT Demod, A/D, HL
Position	LPTAS (L P TURB ACT)	(TBS)	LVDT (5 KHz Ex)	32 Hz (TBS)	±0.25% (TBS)	20 ms (TBD)	5 KHz Ex, LVDT Demod, A/D, HL
Position	1AIPS (PRI Noz)	(TBS)	LVDT (5 KHz Ex)	16 Hz (TBS)	±0.25% (TBS)	20 ms (TBD)	5 KHz Ex, LVDT Demod, A/D, HL
Position	2AIPS (SEC Noz)	(TBS)	LVDT (5 KHz Ex)	16 Hz (TBS)	±0.25% (TBS)	20 ms (TBD)	5 KHz Ex, LVDT Demod, A/D, HL
Position	AWFGS (AUG MTRG Valve)	(TBS)	LVDT (5 KHz Ex)	16 Hz (TBS)	±0.25% (TBS)	20 ms (TBD)	5 KHz Ex, LVDT Demod, A/D, HL
LVDT EXCIT. (See Outputs)	Reference 5 KHz (or 1 KHz or 3.9 KHz - TBD)	(TBD)	N/A	N/A	±0.25% (TBS)	20 ms (TBD)	5 KHz, De-mod A/D, HL
Position	PLA-1	0-10 Vdc	TBS	16 Hz (TBS)	±5 mv of Reading	20 ms (TBD)	+2, A/D, HL
Position	PLA-2	0-10 Vdc	TBS	16 Hz (TBS)	±5 mv of Reading	20 ms (TBD)	+2, A/D, HL
Position	PLA-3	0-10 Vdc	TBS	16 Hz (TBS)	±5 mv of Reading	20 ms (TBD)	+2, A/D, HL
Self Test	A/D Test #1 (REF)	5.0 to 5.25	N/A	N/A	±2.5 mv of Reading	20 ms (TBD)	+2, A/D, HL
Self Test	A/D Test #2 (AN)	+0.1 to -0.1	N/A	N/A	±2.5 mv of Reading	20 ms (TBD)	A/D, LL
Temperature	TBT	±5 vdc	(See #38)	(See #38)	±0.25%	20 ms (TBD)	A/D, HL
Spares	(Measure +5, -5 vdc Excitation, Etc.)						A/D, (1-LL, 2-HL)
Speed (#-TBS)	NL	440-4440 Hz with Gearing (TBS)	Magnetic Tach (Geared) (TBS)	Signal ~5 Vpp use 1.25v Threshold (TBS)	±0.5% of FS (TBS)	20 ms (TBD)	10-1 Range F/D
Speed (#-TBS)	NH	440-4440 Hz with Gearing (TBS)	Magnetic Tach (Geared) (TBS)	Signal ~5 Vpp use 1.25v Threshold (TBS)	±0.5% of FS (TBS)	20 ms (TBD)	10-1 Range F/D
Digital Data	DD-1	TBS	P/S Cnvt'r 16 Bits Data 2 Bits Sync (TBD)	60-18 Bit Words at 1200 words per sec (TBD)	Single Chnl 50', Zo = 75 (TRD)	Direct Digital Cnvt and Mag Tape Record Cap. (TBD)	Miller Code Barker Frame Sync (TBD)
Digital Data	DD-2	TBS	P/S Cnvt'r 16 Bits Data 2 Bits Sync (TBD)	60-18 Bit Words at 1200 Words Per Sec (TBD)	Single Chnl 50', Zo = 75 (TBD)	Direct Digital Cnvt and Mag. Tape Record Cap. (TBD)	Miller Code Barker Frame Sync (TBD)
Discretes	DISIN-X - Duct Pilot Fill - Duct Main Fill - Inlet Reset	±5 vdc ±20v CMV (28v - Signals) (TBS)				20 ms (TBD)	8-Bit Bytes Level-Shift to DECC
Temperature	TBT (Turbine Blade)	±15 vdc ±5%	Supply 1w Ex (TBS)	Integrate and Clip (TBS)	±0.5% of F.S. (TBS)	20 ms (TBD)	Signal Condition, A/D, HL
Discrete	Light Off Detector	(TBS)	Study Alternates (TBS) Excitation Gen (TBS)	(TBS)	(TBS)	20 ms (TBD)	Special Signal Cond'g, Schmitt-Trigger, DISIN8

Table 3.1-4 Sample Output Signal Table

No.	Output Device	Name	Range	Output Specification	Accuracy Goal	Expected Technique*
1	Torque motor	WFGE (Main Fuel Flow)	±40 ma	100 Ω, 8 bits + sign monotonic, 2-wire shielded	±1 bit	D/A, S&H, current driver
2	Torque motor	IGVR (INL GD Vane Rate)	±40 ma	100 Ω, 8 bits + sign monotonic, 2-wire shielded	±1 bit	D/A, S&H, current driver
3	Torque motor	CGR (Comp Geo Rate)	±40 ma	100 Ω, 8 bits + sign monotonic, 2-wire shielded	±1 bit	D/A, S&H, current driver
4	Torque motor	AFF (Avg Fuel Flow)	±40 ma	100 Ω, 8 bits + sign monotonic, 2-wire shielded	±1 bit	D/A, S&H, current driver
5	Torque motor	Spare	±40 ma	100 Ω, 8 bits + sign monotonic, 2-wire shielded	±1 bit	D/A, S&H, current driver
6	Air motor	HPTR (HP Turb Rate)	±100 ma (±400 ma limit)	< 55 Ω, 8 bits + sign monotonic, 2-wire shielded	±1 bit	D/A, S&H, current driver
7	Air motor	LPJFR (LP Jet Flap Rate)	±100 ma (±400 ma limit)	< 55 Ω, 8 bits + sign monotonic, 2-wire shielded	±1 bit	D/A, S&H, current driver
8	Air motor	PNR (PRI Noz Rate)	±100 ma (±400 ma limit)	< 55 Ω, 8 bits + sign monotonic, 2-wire shielded	±1 bit	D/A, S&H, current driver
9	Air motor	SNR (Sec Noz Rate)	±100 ma (±400 ma limit)	< 55 Ω, 8 bits + sign monotonic, 2-wire shielded	±1 bit	D/A, S&H, current driver
10	Air motor	Spare	±100 ma (±400 ma limit)	< 55 Ω, 8 bits + sign monotonic, 2-wire shielded	±1 bit	D/A, S&H, current driver
11	Control diacretes DISO-X X = 1 FE 21 MFCOS 20 MFCOR 31 P&M COS 30 P&M COR 4 DFCO 5 DMCO 6 IGN'N #1 7 F/O 8 SPARE 9 SPARE 10 IGN'N #2 (TBS) ↓ 16	Fuel Enrich Main Fuel Cos MF Cutoff Reset Pilot & Main Cos P&M Cutoff Reset Duct Fuel C/O Duct Main C/O IGN #1 F/O (TBS)	125 ma driver 125 ma driver 125 ma driver 3 A driver 125 ma driver 125 ma driver 125 ma driver 125 ma driver 125 ma driver	2-wire shielded twisted tr, tr > 100 μsec + 50 vdc max (Switching 28 vdc - TBS) (4 A total output cap. - TBS) (2 AC IGN'R power inputs, SWG - TBS)	Switching 28 ±2 vdc (TBS) V _{CE sat} 1V/A max	DISO - 16-bit buffer, output solenoid drivers (12)
12	LVDT excitation	LVDT-EX	10 vrms ±1% 5 kHz ±10% (or 1 kHz or 3.9 kHz ?) TBD	Distortion < 1% 5 watts Z _o < 10 Ω CT XFMR output Short circuit protect frequency derived from DCU clock	V ±1% F ±10% (TBS) Dist < 1%	<ul style="list-style-type: none"> Binary countdown of computer crystal controlled clock (modulo-counter if necessary) Active filter -- Butterworth to generate sine Output buffer driver
13	PLA excitation	PLA-EX	10 vdc	±1% NI to FL 1 watt Z _o < 100 Ω Short circuit protect	---	No sweat
14	Serial data	See Input Signal Table, Input Nos. 35 and 36				
15	Spare D/A Voltage output Chnl 6)	(TBD) For test and indicators	±10 vdc (TBD)	100 Ω, 8 bits + sign	±1 bit	D/A, S&H

*Dependent on TBD and TBS.

Table 3.1-5 Sample Preliminary Design Requirements for an Electronic Controller

Example Requirements for the Electronic Controller
Design Aim Requirements
Production Flight System Cost: 40K maximum Weight: 20 lb. maximum Size: (3 x 12 x 6) in. maximum Power Dissipation: 100 W maximum Reliability, MTBF: 30,000 hr (Use selective redundancy and Provide fail/safe back-up system) Maintainability: (Provide BITE and condition monitor) (Replacement time: 1 hr maximum)
Environmental Requirements
Temperature: -65° to +185°F (Heat exchanger and fuel/air cooling provided) Vibration: ±15G (90 to 2000 c. p. s. with two minute dwell at resonances) (Aero-flex Vibration Isolators provided) Altitude: to 100,000 ft Humidity: Up to 100% Shock: 15G for 11 msec (3 axis)
Electrical Interface Requirements
Inputs: Per Table Outputs: Per Table Power: Dedicated 3 ϕ alternator supplied Cabling: Use fiber optics where possible Pneumatic/Hydraulic Interface Requirements Cooling fuel: See related spec Pressure probes: See related spec

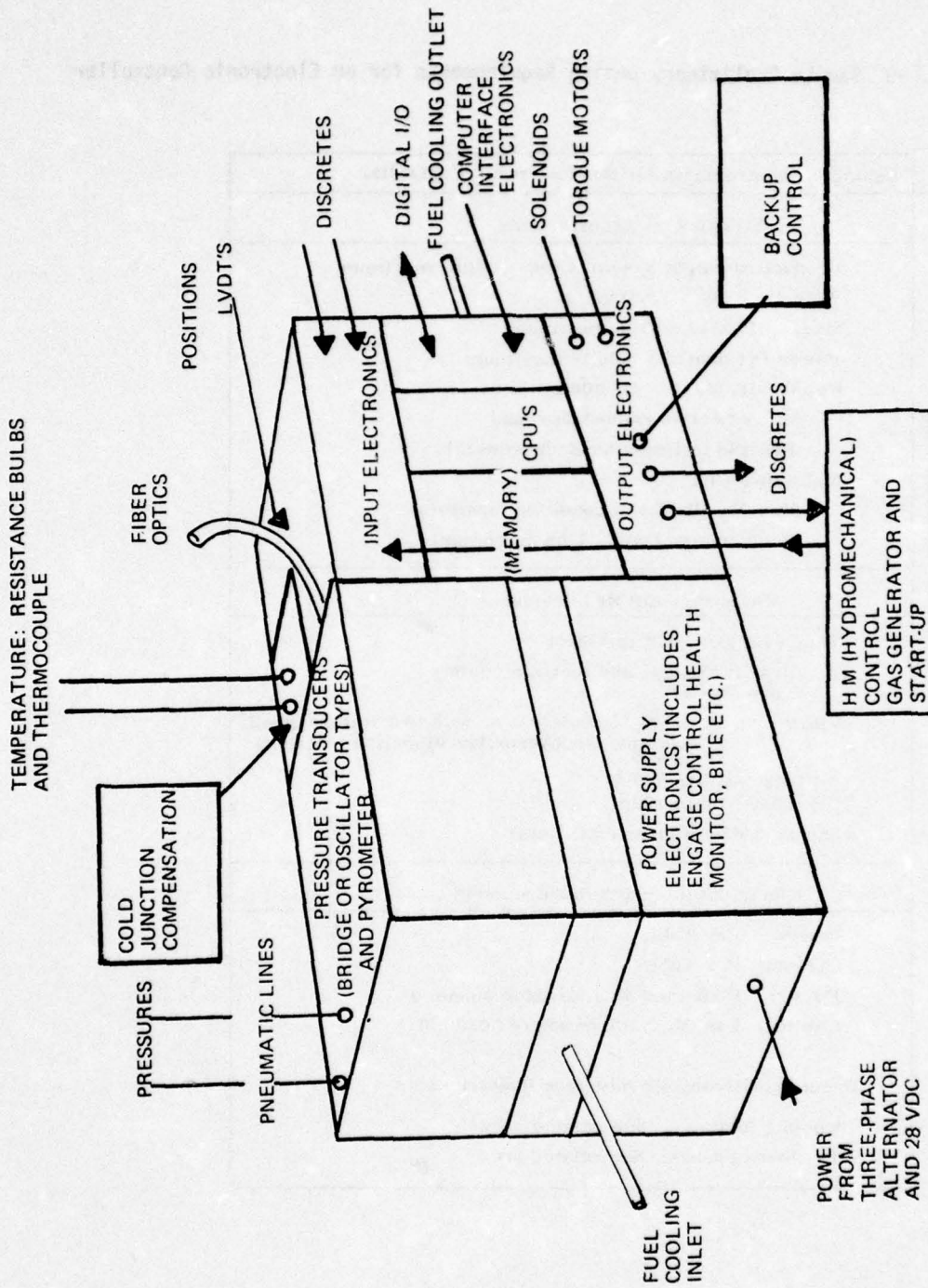

Figure 3.1-3 Example Packaging Diagram (Single Box)

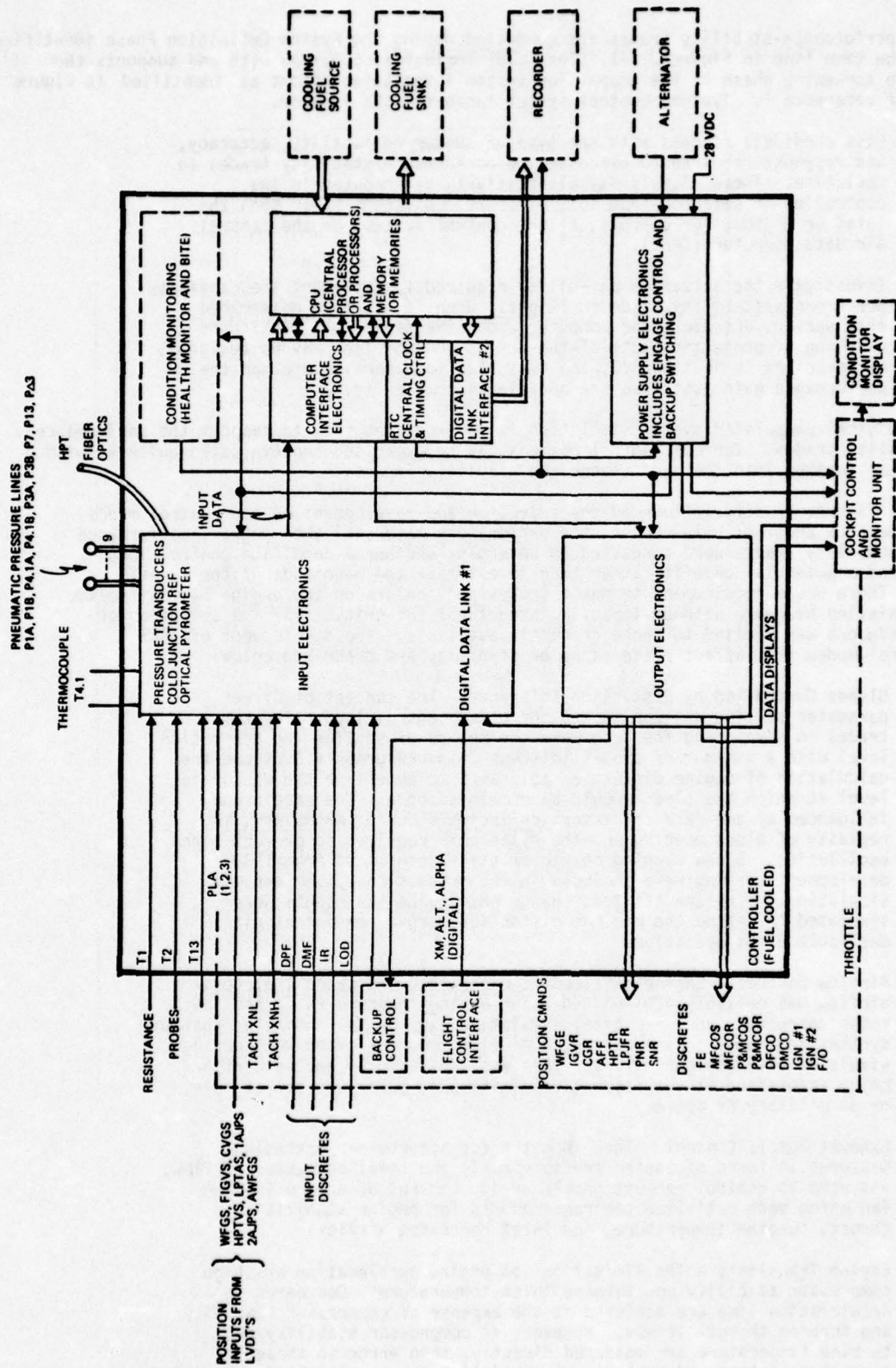

Figure 3.1-4 Example Electronics Block Diagram

The performance-stability trades are conducted during the System Definition Phase identified on the time line in Figure 2.1-1. The study logically coincides with and supports the cycle screening phase of the propulsion system integration effort as identified in Figure 58 of reference 1. Typical control system support tasks include:

List candidate signals with the type of sensor, reliability, accuracy, and response required to exercise the performance/stability trades in real time. These signals may alternatively be computed in the controller or obtained from some aircraft subsystems other than the inlet or engine; for example, flight control system, or the central air data computer (CADC).

Investigate the actuation capability required to implement the candidate performance/stability trade in flight. When it has been determined that sensor, actuator, and computer requirements are all within the existing or projected state-of-the-art, a control loop may be designed, as described in Section 3.3, and evaluated to determine whether the performance gain justifies the additional complexity.

The digital propulsion system simulation is an excellent tool to support the performance-stability trades. Various control options may be exercised and evaluated quickly, with a clear insight into the performance and stability impact.

Three factors greatly influenced the selection and development of new control modes in the IPCS program: (1) Due to the exploratory nature of the program, performance and stability trades were conducted to determine whether a candidate control loop offered a potential benefit rather than to estimate the magnitude of the benefit. (2) There was a requirement to mount probes and sensors on the engine by modification of existing hardware without impacting structural integrity. (3) The selection of transducers was limited to those currently available. The development of IPCS control modes that affect performance or stability are described below:

Bleeds Controlled by Distortion Tolerance - The concept of direct parameter sensing was applied to the bleed control loop. The key trades in developing the loop were the method of sensing the distortion level with a minimum of probes (discussed in paragraph 4.5.2) and the calculation of engine distortion tolerance to determine the distortion level at which the bleeds would be commanded open. The margin was influenced by the rate of distortion increase during maneuvers, the rapidity of bleed opening and the hysteresis required to prevent bleed oscillation. Bleed opening characteristics determined from TF30 development testing were included in the propulsion system dynamic simulation. Airplane attitude change and engine transients were simulated to define the minimum distortion margin consistent with desirable bleed operation.

Airflow Control - Engine development experience indicates that total airflow was reliably synthesized using engine pressure ratio and low rotor corrected speed. Digital simulation experience indicated that the synthesized total engine corrected airflow mode performed well during simulated altitude conditions. This was indicated by engine airflow being maintained at the respective limits when power was set at idle, or at military or above.

Exhaust Nozzle Control - The fan match for afterburner operation, measured in terms of engine pressure ratio and total corrected airflow, was used to control exhaust nozzle area. Control of area using the fan match mode satisfied the requirements for engine stability, thrust, turbine temperature, and inlet corrected airflow.

Engine Transients - The limitations on engine acceleration are high compressor stability and turbine inlet temperature. Decreases in acceleration time are achieved at the expense of compressor stability and turbine thermal stress. However, if compressor stability and turbine temperature are measured directly, then error in these parameters introduced by indirect scheduling can be minimized. Previous studies in the industry indicated compressor discharge Mach number had

potential for controlling compressor excursions during transients. In addition, the Air Force and Honeywell had developed a fluidic turbine inlet temperature measuring system. The results of this previous work suggested modes to limit high compressor discharge Mach number and turbine inlet temperature during engine accelerations. These were developed using the digital simulation to generate the mode requirements and schedules needed for demonstration during engine test.

Low compressor stability and burner flameout limit engine deceleration rates - The engine deceleration limit provides flameout protection, but low compressor instability occurs at some flight conditions. Again taking advantage of previous work, the low compressor discharge Mach number was selected as the stability protection parameter.

The inlet phenomena that tend to limit or degrade engine and vehicle performance are flow distortion, pressure recovery, flow oscillations (e.g., turbulence and buzz) inlet unstart (mixed compression inlet), and bypass and/or bleed drag. Several of these phenomena are fundamental to the engine/air frame integration problem and are treated in depth by Brimelow (reference 1). The inlet subsystem must also be able to tolerate the disturbances listed in Table 3.2-1. In general, the occurrence or severity of these phenomena is a function of flight condition so that fixed stability margins built into the system to tolerate worst cases will penalize the aircraft over the entire flight envelope. Methods of sensing the disturbances must therefore be developed. In the event that the disturbances cannot be sensed, predicting and correcting for them, open loop, is the less desirable, low performance alternative.

The trades and selections made during the IPCS mode development program were consistent with its intent and purpose identified during the study phase. The simulation was used to eliminate some options and provide the basis for final mode selection as agreed upon at the Preliminary Design Review. No changes were made to the basic engine mode during Final Design, except as required for schedule definition, logic refinement, and failure analysis.

Table 3.2-1 Inlet Disturbances

External disturbances	Engine corrected airflow transients
Gusts	Aircraft maneuvers
Aircraft angle-of-attack and yaw	A/B light-off or shut down
Hot gas reingestion	Temperature (T2) transients
Weapons firing or launching of stores	
Major Failures	
Engine shutdown	
Compressor stall	
Gas generator flame-out	
A/B flame-out	

3.3 BASELINE CONTROL ALGORITHM

This section treats the selection of the fundamental input-output relations that are designed or programmed into the control system; open-loop or closed-loop control, isochronous or droop governors, etc. The design of the control algorithm is constrained first by the ability to measure the requisite signals. In fact seven of the eleven IPCS gas generator control loops employed new or unconventional control signals. In evaluating candidate control signals, one must remember to include signal conditioning inaccuracy in the error budget and to allow for signal conditioning time in the stability analysis (See paragraph 4.3.3.4.) After it has been determined that the signal can be sensed with satisfactory accuracy and frequency response, questions of safety, logic, etc. may be addressed.

It is recommended that control algorithms be based as far as possible upon existing successful designs and that these existing concepts be extended as appropriate to incorporate new signals, new actuators, or other novel features.

3.3.1 The Integrated Control Algorithm

The control algorithm may be represented by a block diagram of the mode showing the inputs, outputs, and loops used to control the propulsion system. The preliminary algorithm acts as a basis for a first pass estimate of hardware and software requirements, and must therefore be formulated very early in the program. Refer to time line, Figure 2.1-1.

The procedure used to develop the first pass (baseline) control algorithm involves reviewing the propulsion requirements and determining answers to the following questions:

1. What are the performance/stability goals of the flight system?
2. What are modes of existing systems?
3. How can we improve over the existing system?
4. What propulsion components require controlled positioning?
5. Why are they needed?
6. What are the constraints?

Loops are added to the control to meet requirements in the most direct manner feasible. In reviewing the requirements, care should be taken to relate each requirement to a measurable criterion to determine whether the requirement is satisfied. A review of the performance existing propulsion systems and their modes will indicate how well that control system met its requirements. Information of this nature is invaluable as a basis for establishing mode concepts geared to improvement.

The algorithm is formulated to provide the control intelligence to satisfy the requirements of the propulsion system in the most direct manner feasible, within the constraints of component technology. If existing sensor and actuator technology does not permit direct measurements to satisfy the requirements, analysis is performed to evaluate the performance benefits of new technology devices versus signal synthesis or open-loop schedules. The analysis consists of evaluating the new devices by comparing them to existing hardware, considering reliability, steady state accuracy, dynamic response, cost, weight, and risk to the program. These factors must be evaluated early in the algorithm design process as the outcome will determine the mode of control. Establishing component requirements for the engine in this manner becomes a process iterative with the engine algorithm design.

The IPCS mode used direct measurements of critical parameters to maintain engine limits. In addition destabilizing influences such as distortion were measured and changes made to accommodate the disturbances. The key IPCS features incorporated in the control algorithm were as follows:

1. Isochronous high rotor speed control for accuracy of speed control.
2. Direct turbine inlet temperature measurement for temperature limiting
3. Total engine airflow synthesis for airflow limiting
4. Direct low rotor speed measurement for speed limiting
5. Direct compressor discharge Mach Number measurement for compressor stall protection.

The inlet fulfills two primary functions on the aircraft; provide properly conditioned airflow to the engine and minimize aircraft drag. On some high-performance aircraft it interacts with the flight controls to the point that it may be used to supplement the normal control surfaces or, at the least, flight control interaction must be considered when the inlet control modes are designed.

In an integrated system, the inlet control may act in any one of three ways:

1. Position inlet surfaces in response to signals sensed locally.
2. Develop information or signals that are used in the control of other subsystems.
3. Position inlet surfaces in response to signals from other subsystems.

All three functions were performed by the IPCS inlet control, as discussed in volumes II and III of this report.

The key integration features selected during the IPCS algorithm design process were as follows:

1. Direct measurement of distortion for operation of bleeds to improve distortion tolerance only when needed.
2. Direct measurement of inlet/engine airflow to match engine and inlet airflows.
3. Direct measurement of buzz to provide automatic recovery.

The integration features were formulated during joint design sessions and were added to the control to comply with the requirements of the propulsion system.

The preliminary block diagrams issued at the first tripartite "Preliminary Mode Study Session" had a format as shown on Figure 3.3-1. Diagrams like this were used to determine the first pass estimate of control component and software requirements.

3.3.2 Specialized Integrated Control Loops

Four integrated engine/inlet control loops that can be of direct benefit to flight system performance are described in this section. Three of these were demonstrated in the IPCS flight test program. Exploratory work on a sensor to reduce the fourth to practice was successful.

3.3.2.1 Buzz Detection and Suppression

The IPCS provided the first flight demonstration of the buzz detector developed originally for the Supersonic Transport (SST), reference 2. The essence of the detector is a circuit that responds to large amplitude inlet pressure oscillations over a frequency spectrum that straddles the anticipated buzz frequency. It is not necessary to examine the wave form of any individual pressure pulse. The required response to a buzz signal is an increase in inlet airflow. (Some other recovery strategy may work with other inlet designs.) The SST inlet increased airflow by opening bypass doors; since the F-111 inlet had no bypass doors, buzz was suppressed by accelerating the engine.

The success of buzz detector in the IPCS flight tests and the SST wind tunnel tests provides confidence that buzz can readily be detected and it can be suppressed by an integrated propulsion control system, provided that a strategy is available that will stabilize the flow.

3.3.2.2 Real-Time Distortion Measurement

The success of the IPCS distortion loop hinged on the fact that the F-111 distortion pattern was consistent and repeatable. This condition is probably true of many other installations. In such cases it should be possible to correlate signals from a small number of probes to an accepted distortion parameter. Note that it is not necessary to obtain correlation under all conditions, but only under those conditions and for those distortion levels where significant degradation of stall margin or performance would occur.

A distortion signal may be used to drive the inlet, closed-loop, to a low-distortion configuration, or it may be used to drive the engine, open-loop, to a configuration tolerant of distortion. The low-distortion inlet configuration must be determined experimentally. The distortion tolerance of the engine is discussed in paragraph 3.2.1.

3.3.2.3 In-flight Airflow Optimization

Inlet drag is generally considered to be a function of the engine/inlet airflow match and not to be subject to modulation by the propulsion control system. This situation may change when it becomes possible to vary engine airflow independently of thrust, or, more precisely, to vary airflow independently of fuel flow. A trade may then be as indicated by Figure 3.3-2.

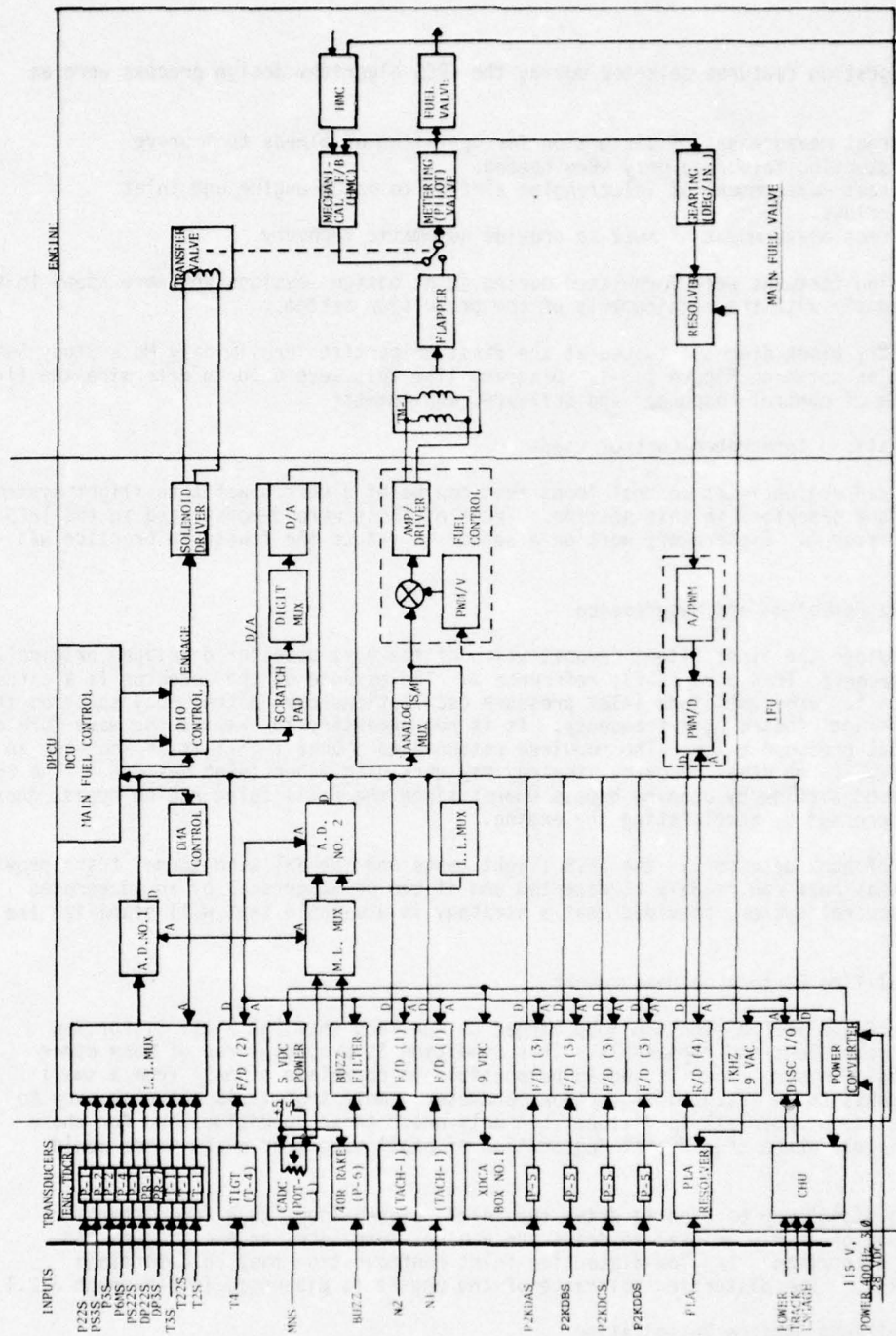

Figure 3.3-1 Gas Generator Control Loop

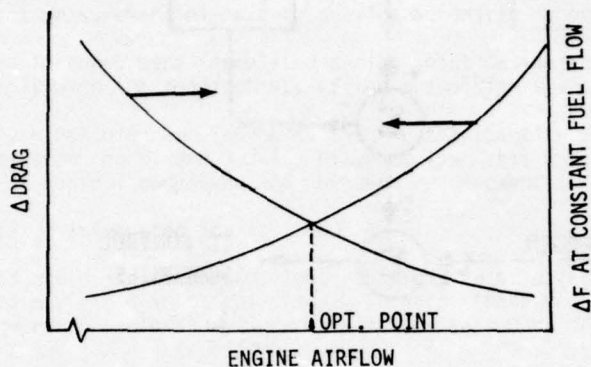

Figure 3.3-2 Airflow Trade Study

The shock probe design explored during the baseline IPCS flight tests (Vol II, paragraph 5.2.4.5) was developed specifically to make inflight airflow optimization possible. The relation between the probe signal and drag increment will have to be determined experimentally, as will the relation between engine thrust and airflow.

It will be noted that the temperature of the transducer mounted in the probe base lagged the free-stream temperature by a significant amount (see Figure 3.4-2). This lag makes it possible to consider the use of an uncooled transducer if the aircraft is capable of only a short supersonic dash.

3.3.2.4 Anticipation Signals

There are many phenomena that induce changes in engine airflow and/or inlet capture area; afterburner light-off or shut-down, engine speed changes, resetting of compressor stators or bleeds, etc. Most of these either result from engine control action or are sensed by the engine control system before the disturbance propagates to the inlet and can be detected by sensors located there.

If the amplitude and rate of the disturbance are such that it threatens inlet airflow stability, it is comparatively simple, with an integrated control system, to anticipate the disturbance in the inlet control loop. The inlet geometry may then be shifted to accommodate the transient, either ahead of time or coincident with its arrival.

The feasibility of this approach was demonstrated on the IPCS. The signal to the afterburner zone one shut-off valve (SOV1) was used to pulse the inlet duct exit Mach number signal (PRDEM) to anticipate the airflow transient that accompanies afterburner light-off. The feature is diagrammed in Figure 3.3-3.

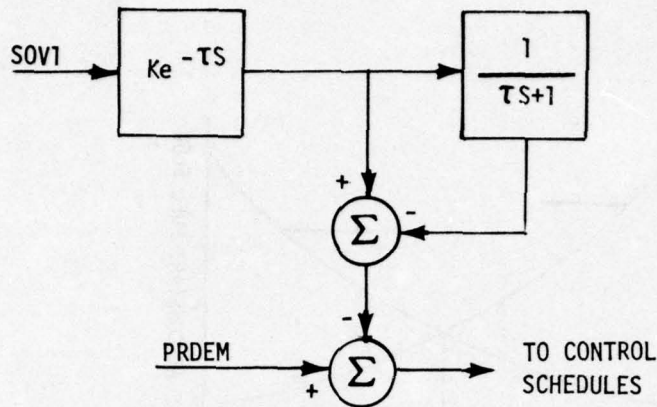

Figure 3.3-3 Anticipation Signal Used in IPCS Inlet Control Loop

It will be noted that the anticipation signal was used to bias the inlet control signal rather than to bias the surface positions directly. Our analysis indicated that this approach is preferable because of the non-linearity between airflow increments and surface positions.

3.4 COMPONENT REQUIREMENTS

The development of component requirements involves the three-way trades between performance, reliability, and cost. This task should be initiated formally as soon as the tentative control algorithm is completed. It may be advisable to make the initial set of requirements somewhat rigorous. These should then be subjected to regular, scheduled reviews to ensure compatibility within the developing system and to relax the early, rigorous requirements as far as possible in the interest of economy and maintaining schedules.

3.4.1 Propulsion System Components

The process of defining component requirements starts with the preliminary control algorithm to develop a flow diagram that indicates the measurements, actuators, and interfaces required. The preliminary algorithm acts as a basis for an initial estimate of hardware requirements that must be followed by an extensive trade study between these requirements and hardware availability. The trade study identifies the hardware to be designed, fabricated, and tested. The algorithm is then modified to reflect these results.

Examples of trade studies that establish the component requirements include the following:

1. Performance trades - After the initial control signals are identified from the algorithm it is necessary to evaluate each individual measurement to determine whether the particular measurement could be synthesized from other measurements, thus eliminating the hardware, risk and cost involved in making the measurements and yet maintain the accuracy and response for loop control.

2. Hardware trades - The hardware trades are really a trade between hardware requirements and performance penalty. It is necessary to determine the number of measurements required at each station to obtain consistent and repeatable signals without compromising the flow path or the structural integrity of the engine.
3. Installation trades - The engine environment is one of the first considerations in determining engine component requirements. If the control algorithm indicates usage of a signal sensed at a location not readily accessible, then a trade is made on the design implementation problems (time, cost, complexity, durability) and weighed against the performance loss associated with a substitute measurement.

Information flow diagrams, which are schematics of the control system interfaces, present a visual picture of the component requirements and are helpful in conducting trade analyses. The initial flow diagrams are derived from the engine control algorithm. The information flow diagram for one of the IPCS control modes is shown on Figure 3.4-1. The design engineer reviewed the diagram and listed all the components to indicate their performance requirements.

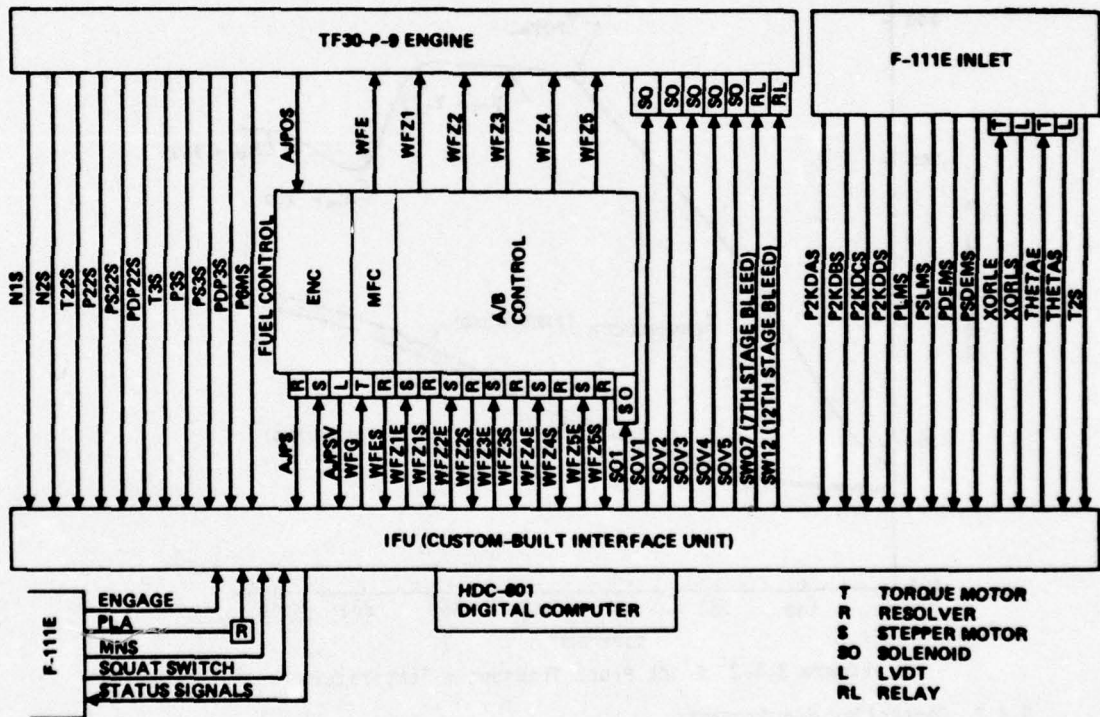

Figure 3.4-1 Information Flow Diagram

There exists a trade between control mode requirements and hardware. The control mode usually indicates direct measurements as the best approach, while hardware studies indicate minimizing measurements as being the most reliable and cost effective, and least risky to the program. In several instances, it was possible to eliminate measurement requirements. For example, the initial flow diagram indicated a need for total pressure and temperature measurements at the entrance of the low pressure compressor. After an initial review of the design requirements for the probes, it was decided that a cost savings could occur if an alternative measurement were used. In this case, it was possible to define a performance correlation that permitted use of engine inlet pressures and temperatures instead. Accuracy analyses, including engine to engine variations and engine degradation, were very important in establishing parameter substitution in lieu of direct measurements.

The environment to which airframe components are exposed tends to be more benign than that on the engine. This generalization must be evaluated carefully, however, in the case of high performance aircraft, where both the temperature and vibration levels in the inlet area may approach those associated with the engine bay. The time for which the components are exposed may be much shorter for those units mounted in (or on) the airframe, however. For example, Figure 3.4-2 shows the temperature history of a transducer that was mounted on the cowl of the IPCS F-111E test aircraft. Since the F-111 is capable of only a short period of high-speed flight, the thermal lag of the transducer was sufficient to prevent over-temperature. Figure 3.4-2 also indicates that it is possible to calculate the thermal history of components with reasonable accuracy even when the geometry and the flowfield are complicated.

Passive protection, e.g., synthetic foam, should be considered for sensors that dissipate so little power internally that self-heating is not a problem. (See Section 6.5.).

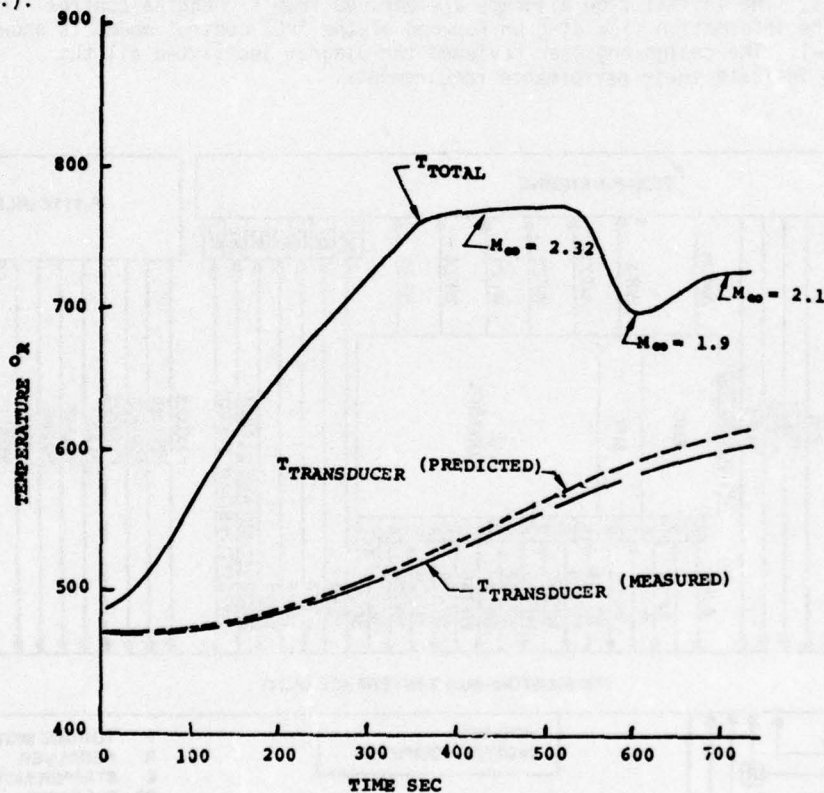

Figure 3.4-2 Shock Probe Transducer Temperature

3.4.2 Controller Requirements

The development of controller requirements constitutes a system engineering task that will generate a detailed design specification for the controller. An analysis of the control algorithms provides the basis for specifications for the processor (computer) memory and software. The number of control loops, the number of bi-variate and univariate functions, the logical control switching functions, data-bank sizing, and control loop response times provide the data required to establish processor speed, instructions list, memory size, and configuration requirements. These specifications will become part of the "Base-line Propulsion System Definition and Requirements" document.

3.4.2.1 Control Algorithms to be Implemented

The baseline control algorithms defined in Section 3.2 will be restated from the standpoint of the controller. FORTRAN statements excerpted directly from the digital simulation program may be used to develop Functional Control System block diagrams similar to Figure 3.4-3 which was developed for the IPCS.

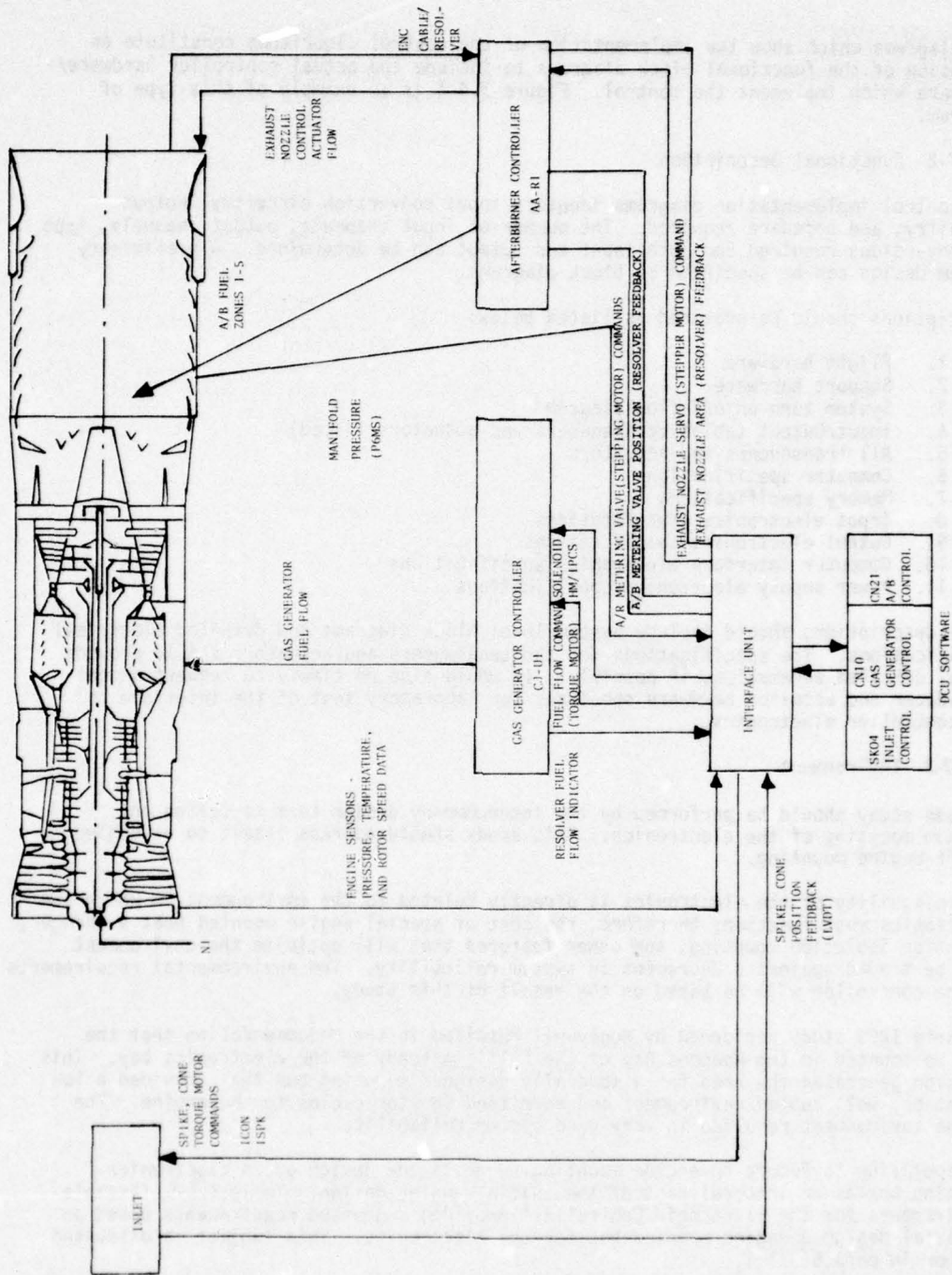

Figure 3.4-3 Functional Block Diagram

The diagrams which show the implementation of the control algorithms constitute an expansion of the functional block diagrams to include the actual controller hardware/software which implement the control. Figure 3.4-4 is an example of this type of diagram.

3.4.2.2 Functional Description

The control implementation diagrams identify input conversion circuitry, output circuitry, and software required. The number of input channels, output channels, type of conversions required for both input and output can be determined. A preliminary system design can be specified by block diagrams.

Descriptions should be provided as listed below:

1. Flight hardware
2. Support hardware
3. System turn-on/off flow diagram
4. Input/Output tables (transducers and actuators listed)
5. All transducers and actuators
6. Computer specifications
7. Memory specifications
8. Input electronics specifications
9. Output electronics specifications
10. Computer interface electronics specifications
11. Power supply electronics specifications

These descriptions should include system level block diagrams and detailed electrical specifications. The specifications for the transducers and actuators should provide actual detailed schematics, if possible. It would also be timely to request actual transducer and actuator hardware specimens for laboratory test of the interface to the controller electronics.

3.4.2.3 Environment

A trade study should be performed by the intercompany design team to define the optimum mounting of the electronics. This study should address itself to on-engine vs off-engine mounting.

The reliability of the electronics is directly related to the environment in which the electronics must function; therefore, the cost of special engine mounted heat exchanger, vibration isolation mounting, and other features that will optimize the environment must be traded against a decrement in system reliability. The environmental requirements of the controller will be based on the result of this study.

An early IPCS study performed by Honeywell resulted in the recommendation that the DPCU be mounted in the Weapons Bay of the F-111 instead of the electronics bay. This decision generated the need for a specially designed mounting box that provided a low vibration, well cooled environment and permitted shorter cables to the engine. The benign environment resulted in very good system reliability.

Extrapolation to future on-engine mounting suggests the design of an electronics mounting box as an integral part of the initial engine design. Table 3.1-5, "Example Requirements for the Electronic Controller" provided suggested requirements based on a special designed engine mounted box for the electronics. This subject is discussed further in para 6.3.1.1.

3.4.2.4 Interfaces

The DPCU interfaces were listed in the design specification by tables and wire lists. The early definition of these wire lists was important as it established connector/cable configuration control, EMI characteristics and cable weight data. In addition to the wiring interface, pneumatic and hydraulic interfaces must be defined. Cooling air (if used) must be specified, for example.

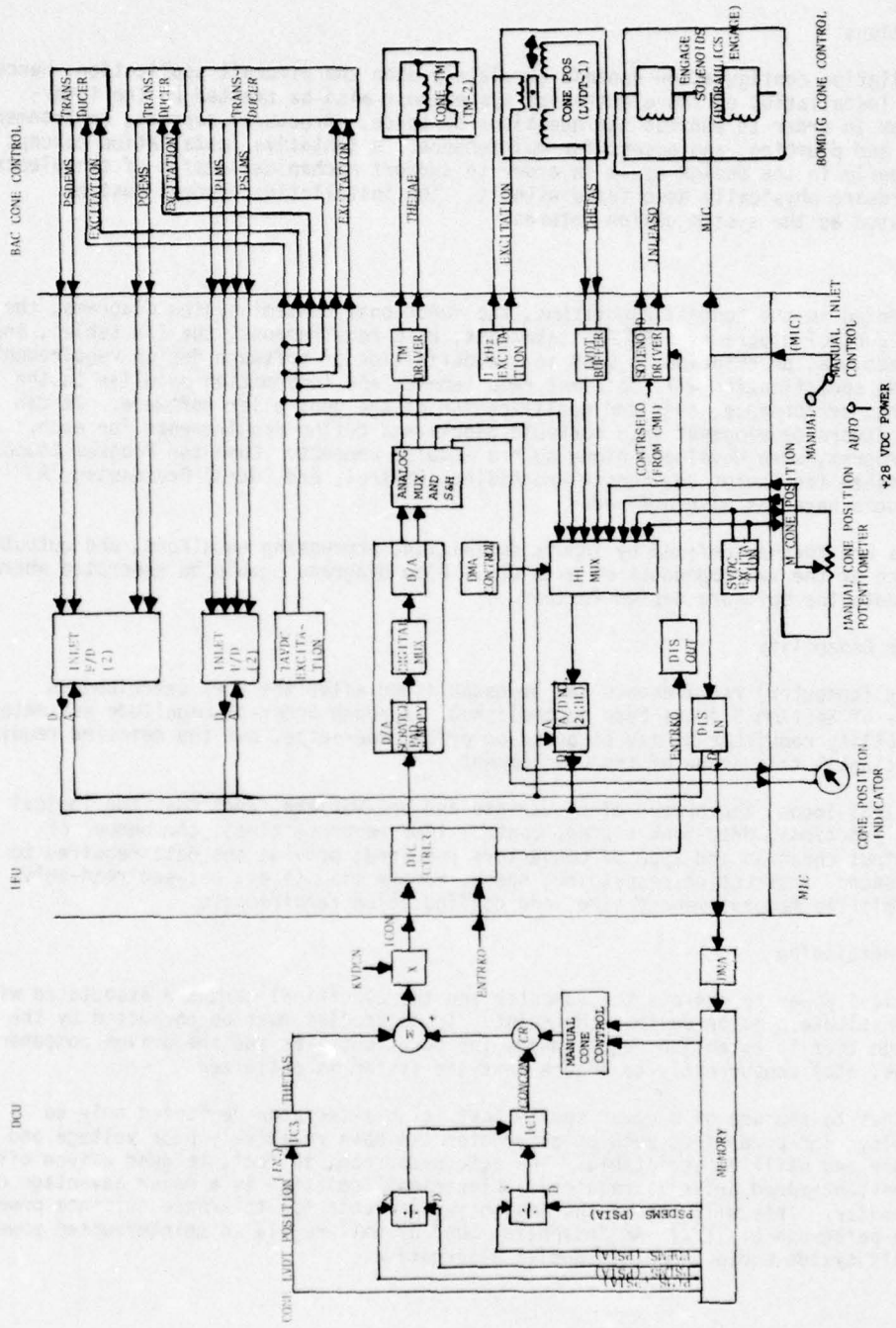

Figure 3.4-4 Implementation Diagram

3.4.2.5 Installations

The optimum installation configuration depends completely upon the aircraft application. Hence the packaging and installation of the electronics system must also be treated by the inter-company design team in order to address the questions of space, structural support, environment, routing of wiring and plumbing, and access for maintenance. A tentative installation concept must be selected early in the design cycle in order to support mechanical design of the electronics module and the hardware physically associated with it. The installation concept must be reviewed and adjusted as the system design matures.

3.4.2.6 Software

Information documented in the control algorithms, the functional control system diagrams, the implementation of control diagrams, FORTRAN statements, BITE requirements, the I/O tables, and the controller functional description is used in the definition of software design requirements. The software design specification will document requirements and information peculiar to the design, development, performance, test and qualification of the controller software. It can also divide the software development into workable blocks and define requirements for each. The IPCS/BOMDIG programs were developed along such a modular concept. Computer Program Components (CPC) were established for Executive, Sensor Processing, Control, and Output Processing. A computer program data base was also defined.

The software CPC's are further defined by inputs definition, processing equations, and outputs definition for each of the subcomponents of each CPC. Flow diagrams should be generated where required to delineate the software design further.

3.4.2.7 Processor Capability

Detailed processor (computer) requirements can be established after the work described in earlier paragraphs of Section 3.4 has been accomplished. A rough order-of-magnitude estimate of processor capability requirements may be based on prior experience, but the detailed requirements must be left until this stage of the development.

The number of control loops, the number of bi-variate and uni-variate functions, the logical control switching functions, data-bank sizing, control loop response times, the number of hardware input/output channels and type of convertors required; provide the data required to specify the processor: instruction repertoire, speed, memory mix, (i.e., between read-only, read-write, and volatile memory) memory size, and configuration requirements.

3.4.2.8 Power Conditioning

Sources of electrical power to operate the computer and the electrical hardware associated with the controller constitute a major design constraint. Trade studies must be conducted by the intercompany design team to establish requirements for power supplies and the driven components (motors, solenoids, etc) concurrently to ensure that the system is optimized.

There are advantages to the use of a power source that is an alternator dedicated only to propulsion controls. The power from such an alternator can have relatively poor voltage and frequency tolerance and still be acceptable. The alternator can, in fact, be gear driven off the engine; no constant-speed drive is required. Electrical isolation is a major advantage of a dedicated alternator. This will reduce the design requirements for tolerance nuisance power transients. (See paragraph 6.3.1.2) An "essential bus" of well-regulated uninterrupted power within the aircraft system would be an attractive alternative.

3.4.2.9 Input/Output

The requirements for the input and output electronics are directly related to the sensors and actuators selected. Care must be taken in the selection of those devices so they will not complicate I/O design requirements. Stepping motors, vibrating crystal pressure transducers, special 33V dc devices, high power solenoids, and the TIGT sensor are examples of devices used on IPCS that required a complex I/O configuration. These trades are discussed further in paragraph 6.3.1.9.

Tolerance and timing requirements should be analyzed to prevent "over-kill" designs. In addition, as a design goal, control algorithms should be developed that will reduce the tolerance requirements as far as possible. Liberal I/O tolerance specifications will enhance system reliability, because circuits with fewer parts can be used.

3.4.2.10 Built-In-Test Equipment (BITE)

Both hardware BITE and software test routines were used effectively on IPCS. The following design methodology was used:

1. Development of a DPCU start-up/shut-down flow diagram (Figure 3.4-5).
2. Development of System Block Diagram with defined features relating to start-up/shut-down requirements.
3. The development of status and engage boolean equations after preliminary hardware and software design was completed.
4. Definition of status and engage hardware requirements.
5. Preliminary Failure Modes and Effect Analysis (FMEA) of total system.
6. Inclusion of additional hardware design features based on preliminary FMEA.
7. Development of additional software test routines as required.

The development of BITE requirements should follow the same development procedure. The initial requirements should include a flow-diagram similar to Figure 3.4-5. In addition, the concept of BITE must be applied in both hardware and software. DCU self-testing should provide 99 percent confidence that any DCU failure will be detected. In addition, manual emergency shut-down must be provided as last ditch protection.

3.4.2.11 Expansion Options and Flexibility Features

The development of expansion option and flexibility requirements for a prototype system should include certain features:

1. Input electronics that can write 128 memory words through DMA. The DCU must not be able to write in those 128 locations.
2. Provide 50% spare memory capability. Note that the cost of core is decreasing while the cost of programming is increasing..
3. Provide spare input and output channels. Eight spare analog and eight spare discrete channels are suggested each for the input electronics and the output electronics.

3.4.2.12 Signal Noise

The IPCS experience with signal noise and sensor accuracy was deceptively pleasant. Transducers were selected to meet conservative requirements, electronics and cabling were constructed to best possible practice in terms of shielding, grounding etc., and computer capability, core and cycle time, were ample. Cost of these elements was not a major concern.

In a production program system cost considerations will force the use of minimum acceptable equipment and difficult decisions. The following guidelines are offered based on the IPCS experience.

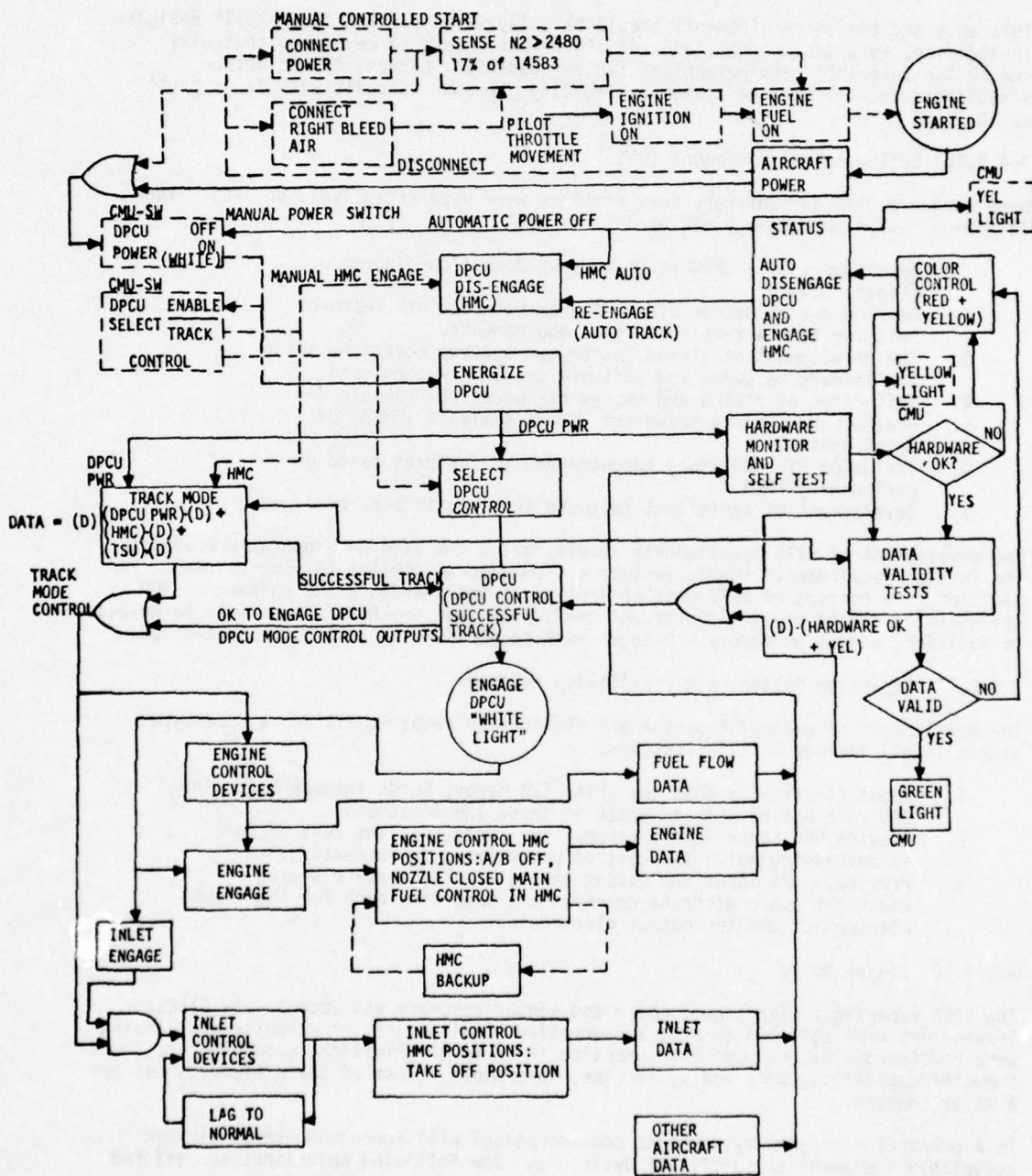

Figure 3.4-5 DPCU Start-Up Flow Diagram

1. Analog processing circuitry and cabling design should emphasize noise suppression over cost.
2. 12 bit A/D-D/A converters are a good practical compromise between cost and utility.
3. When using digital or AC sensors beware of beat frequency or carrier frequency aliasing and sampling effects.
4. Noise sensitivity of control algorithms should be emphasized as a trade parameter in selecting control algorithms.

IPCS experience confirms that good design practices result in a quiet system. These include:

1. Single point ground,
2. Twisted pair wiring for noise reduction,
3. Isolate digital and analog signals in wiring harnesses,
4. Use both low frequency and RF shields,
5. Careful attention to high frequency effects in electronics box grounding system design.

High frequency noise and aliasing in the analog sampling process are avoided by low pass filters on the input side of the multiplexer. Selection of these filters is based on system characteristics - design sample rate, available sensor performance and controller sample rate. A first order lag with a 16 Hz corner provided acceptable results for IPCS.

The N1, N2, and T4 sensors exhibited excessive noise levels during the IPCS program. The N1 and N2 noise were eliminated by increasing the sample rate to obtain a sampling duty cycle, defined as number of events sampled/total samples generated, of 70%. Initially this was thought of as a simple averaging approach to minimizing random noise. After data reduction it is evident that the relatively low original sampling duty cycle, 11%, created a potential aliasing situation and tachometer characteristics and/or gear train resonance were of a frequency to be mapped into the low frequency control range.

3.5 RELIABILITY REQUIREMENTS

3.5.1 Purpose and Scope

The reliability methodology discussed here has been derived from the experience accumulated during the IPCS program and a post-program assessment of significant aspects. The basic IPCS reliability program ended at the final design review, the failure reporting program continued throughout the test program, however. Sufficient time has elapsed to employ some of the IPCS techniques on other programs. On these programs the IPCS methods proved effective. In other cases the rationale used to conduct certain activities proved useful and eliminated the proverbial "starting from scratch".

It was assumed that the future program is sufficiently similar to the IPCS program that the reliability methodology can be applied directly.

The discussion of reliability methodology covers two areas: (1) program control requirements such as developing a program plan, establishing a parts selection and control program, subcontractor control and failure reporting, analysis and corrective action, and (2) analysis requirements such as numerical estimates of system reliability and FMEA's.

The specific goal of the IPCS reliability program was to preclude three different approaches to each reliability task. With the combined reliability experience of the three contractors, it was demonstrated to be possible to formulate one, consistent approach to meet the program requirements. If a future program were to involve subcontractors with less reliability experience than the IPCS team, it may be beneficial to tailor the reliability program for the subcontractor and dictate specific approaches and methods.

3.5.2 Reliability Tasks

This section deals with the requirements appropriate to the design, development and test of an integrated propulsion control system and the rationale used to develop the methods and procedures to carry out the required tasks.

3.5.2.1 Reliability Program Plan

The IPCS statement of work specified each reliability task or requirement. These tasks form the basis of the traditional reliability specification MIL-STD-785A. The unique aspect of the IPCS statement of work was that the methods of accomplishing the tasks, usually spelled out in great detail in the MIL-STD, were left to prime contractor to define. There are good reasons for this approach:

1. The IPCS program was an exploratory development program and Government was aware of the possible need to develop unique approaches to satisfy the requirements within the time and cost constraints of the program.
2. MIL-STD-785A methods can be quite costly and are justified for large programs of long duration where both hardware and data management problems are well defined.

The IPCS reliability program developed by each contractor presented a brief statement of each task to be performed, the organization responsible for that task, the methods to be used, and the schedule for each task output.

3.5.2.2 Subcontractor Control

Subcontractors' interpretations of MIL-STD-785A can vary. On IPCS it was the responsibility of the Prime Contractor to bring these differing, but not necessarily conflicting, approaches together to accomplish the reliability requirements of the program. This was accomplished through the Reliability Program Plan, approved by the Prime Contractor and through person-to-person contact within the various engineering specialistics.

3.5.2.3 In-House Reliability Program Requirements

Most large corporations have Policy Statements addressing Reliability. The Reliability Manager is required to define project reliability requirements for each new program which reflect the contractual aspects of the Program and identify the working relationships between Design, Reliability and related organizations. These documents serve to guide the in-house activities relating to satisfying the Program reliability requirements. On an experimental program, only a minimum number of in-house procedures are necessary to accomplish the required tasks. The rationale for developing in-house operating procedures is to ensure that reliability gets the support needed to accomplish the required tasks; no more - no less.

3.5.2.4 Parts Program

One of the most important aspects of a new development program is the policy on Parts Selection and Control. On IPCS, the Program Plan clearly defined part quality levels and derating requirements. The selection of parts served to establish for the Subcontractors the reliability philosophy for their programs. The rationale for including the parts program in the reliability plan was to avoid producing a separate document which is costly and, more importantly to keep this significant item in the reliability document itself. MIL-STD-749B provided the mechanism for justifying the usage of non-standard parts (NSPs), i.e., parts not on the preferred parts list, since many circumstances can preclude the use of preferred parts.

The philosophy clearly specified in the IPCS Statement of Work required that ER (Established Reliability) level parts be used. With the parts quality spelled out, IPCS developed a straight forward parts program listing every part type and its corresponding MIL-SPEC. Parts not available from the IPCS parts list were used and justified per MIL-STD-749B. The customer was provided with every NSP written on the program to provide visibility on the non-standard parts that were used.

3.5.2.5 Failure Mode and Effects Analysis (FMEA)

MIL-STD-785A requires a Failure Mode and Effects Analysis. This analysis can be a very powerful and useful study since on a small program all possible failures can be examined and traced through the system to establish the effects on the system during various phases of the mission. This analysis serves better to identify design problems than a numerical prediction, as it requires the designers to examine the system end-to-end without being concerned about the probability of occurrence. If a failure mode is deemed critical, the reliability analyst can then assign a probability value or failure rate to prioritize the failure modes and provide Management with a guide for a redesign strategy, if necessary. Particular emphasis was placed on examining failure mode effects at interface points, e.g., where Honeywell's IFU interfaced with P&WA actuators. Each IPCS contractor performed the FMEA on their own hardware and traced the effects of the failure through the system and assessed the criticality of each. Interface failure modes were cross-checked to determine the effect of failure modes on the system and each contractor's hardware. In this way a countercheck was made possible on the failure effects at the system level.

One of the benefits of the FMEA is the identification of backup modes of operation required in the event a primary unit fails. Backup modes include the use of redundant or alternative combinations of hardware or software to accomplish the same function.

3.5.2.6 Numerical Reliability Requirements

Numerical requirements, in terms of an MTBF or Probability of Success are imposed on most military program, although this was not the case for IPCS. The requirements can take either of two forms:

1. A minimum acceptable value (to be demonstrated by analysis or test)
2. A goal (failure to meet the goal would not incur penalty)

The requirement establishes reliability as a performance criterion that will be given the same level of consideration in design as any other parameter so that the concepts under evaluation will not be compromised with respect to the reliability requirements.

In the case of IPCS the goal was not only to advance the state-of-the-art relative to digital computer control of an aircraft propulsion system but also to ensure the safety of the flight crew. In fact, since reliability is an important consideration in the acceptability of electronic digital controls, reliability became an objective in itself.

It is important that the appropriate model representing the failure probability distribution of the system under analysis be selected. Only good judgement and experience with similar systems can provide the basis for choosing the proper mathematical model.

3.5.2.7 Failure Reporting, Analysis, and Corrective Action

MIL-STD-785A requires an extensive effort for failure reporting, analysis, and corrective action. These requirements are absolutely necessary on a large program in order to accumulate failure data and to document corrective action. The failure reporting system requires a single report immediately following the failure, followed by an analysis and corrective action report approved by Reliability and the Program Manager.

3.5.2.8 Design Reviews and Coordination Meetings

Separate design reviews were held during the IPCS program for each contractor. At these reviews the reliability prediction, FMEA and parts program tasks were discussed. Since the ground rules were previously established, the Government presentations were always consistent: At each review Boeing presented an overview of the total IPCS reliability program. The intention there was to avoid a fragmented reliability story throughout the program.

3.5.2.9 Project Organization

On IPCS, the three contractor reliability groups reported directly to their respective Program Managers. This is generally not the case on large programs. The major benefits of this approach are:

1. The program manager is constantly aware of the status of the reliability program.
2. Reliability can get immediate resolution of problems within his own organization or between the subcontractors.
3. The program manager has the reliability group at his disposal to work special problems without adding to the work load of the Design Manager.

3.5.3 Assessment of the IPCS Reliability Program

As indicated in Section 3.5.1, enough time has elapsed since completion of the IPCS reliability program to "stand-back" and evaluate the merits or shortcomings of the approaches taken. Table 3.5-1 summarizes the results of this evaluation.

The IPCS FMEA approach was recently used on the Boeing Compass Cope program with much success. A parts control problem was experienced on a subsequent program because procedures similar to those used on IPCS were not followed.

3.5.4 Engine Reliability Requirements

Reliability requirements for propulsion system control are determined by the requirements established for the overall "weapons system" by the customer. The system integrator establishes a numerical reliability "budget" value or target for the propulsion system which when factored together with other airplane system will meet the customer requirements. The propulsion system reliability budget is divided between the various major components of the system to permit definition of the requirements imposed upon the propulsion control system.

Reasonable numerical reliability requirements should be established by the system integrator early in the design process, so that the requirements could be met as far as possible by using off-the-shelf components and state-of-the-art design procedures.

The key to success of a reliability design is to provide a contractor environment where there is free and continual communication between the working-level reliability personnel of the participating contractors throughout the program. This not only provides the basis for exchange of the best information required but permits a timely resolution of problem areas. Good documentation of all decisions relating to reliability is essential. The documentation should be in two levels. One would be a formal exchange of information between contractors using the coordination memo system. The other would be a less formal meeting between working level engineers at each contractors site to permit early identification of the reliability impact on the various components being designed.

In summary, successful reliability functioning requires a program management decision to permit the flexibility required to do the job at a level wherein reliability personnel of each contractor get to know each other and work together to arrive at a point where the overall system reliability budget is not exceeded.

3.5.5 Electronic Reliability Requirements

It is important that an electronics specialist be involved in the initial engine development. This involvement is necessary so that the mechanical, thermal, and electrical interfaces can be optimized to provide a reliable controller.

Reliability is obtained through the application of all of the following basic considerations:

Table 3.5-1 IPCS Reliability Program Assessment

TASK	IPCS APPROACH		SUCCESS ASSESSMENT
	PRO	CON	
Reliability Program Plan	Revised document after coordination meeting defined parts control program, FMFA, predicted ground-rules and failure reporting procedures	Initial document too vague, schedules not per contract, CDRL items not recognized/ addressed properly	Based on past experience the prime contractor should have been more specific at the outset of the program. The resultant coordination meeting however was the key toward establishing the requirements and working relationships among the three contractors on IPCS which carried through the entire contract.
Subcontractor Control	The close working relationships established early in the program were the key to meeting all reliability objectives		The success of any program, large or small, depends on the cooperation of all concerned. The IPCS approach of unrestricted communication among the design and reliability engineers was an extremely successful approach. This represented a departure from the usual approach of n-levels of management approval of what is going on at the working level.
Prediction	All ground rules agreed upon by the three contractors, all data sources were identified mathematical reliability function was agreed upon.	Software reliability was included in the system reliability model but not adequately addressed due to lack of data	The prediction effort went smoothly, compared to other programs, because data was available on the DPCU and engine components.
Failure Modes and Effects Analysis (FMEA)	The three contractors were experienced in FMEA's and adopting common groundrules was no problem.	Due to the time constraints of the program it was not possible to go "inside" the DPCU. Only the outputs of the DCU, IFU were examined.	The FMEA was the most significant reliability accomplishment of the reliability program. The interfaces among/between the three contractors' hardware were thoroughly examined. In contrast to a prediction where there are known variations in failure rates, the FMEA identifies and qualitatively assesses the criticality of every failure mode. The results provided each contractor and the Safety Board with the engineering confidence that the IPCS system was reliable and safe.
Parts Program	Part quality levels were agreed on, derating criteria (although different within each company) were tailored to common levels; Non-standard part criteria were established	Non-standard part justification data was not as complete as expected but did meet the intent of MIL-STD-749B	Documentation requirements for NSP's per MIL-STD-749B can be satisfied by joint Government/ Contractor agreement to minimize the paper-flow thereby reducing cost. Specification of part quality level early in the program and identification of the specific part specifications applicable to the program includes later misunderstanding. This approach was very successful on IPCS.
Failure Reporting, Analysis and Corrective Action	A simplified approach was adopted, in contrast to MIL-STD-785A but was adequate for IPCS	In some cases, simplicity led to complacency, not deliberately but due to schedule and other problems failure reporting was sometimes "not per spec."	This simplified approach seems to provide as much data as a large data collection program. On large programs the amount of failure data requires more formalized procedures for processing, such as computer print-outs, monthly reports, etc. On IPCS and smaller programs of short (3-4 yrs) duration a failure reporting system similar to IPCS is quite adequate.
Program Management	Reliability reported directly to the Program Manager		This was a highly successful approach since Reliability had direct access to the Program Manager at all times. On larger programs Reliability is often times part of Systems Engineering without direct access to the Program Manager.

1. System Configuration - The application of the following as appropriate: Backup control, dual channel redundant, triple channel redundant, crossfeed, BITE (Hardware and Software), DCU Self-test, asynchronous I/O channels with synchronous BITE and crossfeed, redundancy of sensors and actuators.
2. Selection of Reliable Component
3. Component De-Rating
4. Conservative Design
5. Low-Risk Packaging
6. Design for Relief of Environmental Requirements
7. Quality Control Inspections
8. Temperature-Cycling of Complete Operating System
9. Acquire adequate operational time on the complete operating system to eliminate infant mortality prior to shipment.
10. Vibration of complete operational system
11. All-inclusive testing
12. Pride in workmanship

Items 2 through 12 of this list are obvious and were applied in the development, design, fabrication, and testing of the Honeywell DPCU. Item 1, however, provides an additional possibility for greatly increasing the reliability of the controller. The use of crossed redundant channels and conventional airborne electronic environment can provide reliability numbers greater than 30,000 hours for a flight control system. Assuming that a flight control system has complexity equivalent to an engine control system, it is feasible to configure a system with like reliability.

3.6 QUALITY ASSURANCE PROGRAM PLANNING

Assignment of a Q.A. specialist will occur during contract definition and approximately 60 days before proposal submittal. His assignment during this period will include participation in initial planning with other functional groups, i.e., Engineering, Manufacturing, Materiel, etc. Development of a basic quality approach will be initiated and become a part of the proposal. This will include a general description of the Company's Quality organization and system plus a planned approach for performing the desired degree of quality inspections, surveillances and documentation required. For the proposal effort, this information will be generated against known or recommended planned tasks and schedules. The Quality proposal will define quality tasks during the design effort, manufacturing, procurements, testing and integration. For example, during a specification test operation, Quality support or participation will be recommended and correlated to the test schedule.

In this manner, an estimate of the required Quality resources and manpower can be established and made a part of the proposal. An estimate of this nature can be established for each known task including a definition of the personnel qualifications required for completing the task. The manloading can be time-phased against the proposed schedules. It must be recognized that the initial proposal effort is preliminary and will require expanding or updating as program requirements become more definitive.

The Q.A. specialist's effort during this contract definition phase may be a full-time assignment or part-time depending on the scope of the work to be accomplished and on the budget allocated for the effort.

4.0 CONTROL MODE DESIGN

Control mode design bridges the gap between the conceptual design developed per paragraph 3.3 and the detailed definition of control modes required for physical implementation of the system. The following results are achieved in the process.

- Confirmation of the baseline control algorithm
- Development of logic networks
- Selection of gains, setpoints, and compensation
- Corroboration of component accuracy and frequency response requirements defined per paragraph 3.3
- Development of failure detection and back-up modes to meet reliability requirements of paragraph 3.5.

The paragraphs below discuss the analytical tools used for control mode design - computer simulation, classical linear analysis, and optimal control theory. Special emphasis is given to the use of computer simulation because of the role it can also play in hardware and software testing and in making the transition from subsystem to system-level testing.

Some of the options available for failure detection and back-up modes are discussed in light of IPCS experience.

4.1 THE ANALYTICAL DESIGN TEAM

The propulsion control mode design process starts with a Preliminary Design Phase using the conceptual mode design developed during the requirements definition phase and continues through system development, frequently into the early deployment of the flight system. An Analytical Design Team should be formed early in the process and consist of members from each contractor. The team should include airframe, engine, and control manufacturer personnel familiar, not only with control system operations, but also with their respective plant requirements, operating characteristics, and design processes. Some members should be identified early in the design process as responsible for test design and support in order to achieve continuity between the design and test process. The design team would work through a series of joint design sessions to arrive at a Mode Design.

After delivery of hardware and software, the design team would support the test program as required to ensure that satisfactory control operation is achieved; essentially continuous support should be provided at the test site.

Figure 2.2-2 shows the preliminary design phase work breakdown schedule used in the IPCS program to identify the division of responsibility, the joint design sessions, and document exchanges.

The first period should be used by each contractor in preparation for the First Joint Contractor Analytical Design Session. The responsibilities of each contractor at the first meeting would be to:

1. Describe their propulsion system components.
2. Review their analytical capabilities and computer facilities.
3. Identify requirements and design criteria.
4. Summarize design progress to date, and lastly, but certainly not least,
5. Introduce team members from each contractor to each other.

The goals listed below should be pursued at the first meeting:

1. Establish meeting objectives
2. Agree on system requirements
3. Determine analytical procedures
4. Define contractor assignments
5. Agree on a schedule for making decisions
6. Brainstorm ideas
7. Exchange technical material
8. Establish ground rules, priorities, and success criteria.

Each meeting should conclude with a list of action items and due dates for each contractor responsibility.

The first meeting would probably set the pattern for the remaining meetings. The total number of joint design sessions would be agreed upon at the first session for the preliminary design phase. Each session would follow a procedure that involves reviewing the work performed, establishing approaches, setting priorities, and establishing work assignments. The duration of the design sessions could be two weeks or two days depending upon the task at hand. The first session would be the most important and most difficult one, since it is here that the actual program participants establish requirements and design approaches.

In the IPCS program the "joint session" design approach worked well, providing a means for communication which was considered a very important part of the design process, that resulted in maximum coverage of all problems identified by the various contractors. The general procedure for obtaining a mode configuration was for one contractor to present an approach to satisfy requirements, and for the other contractors working to critique. The result was a committee refinement of a particular design which was then committed to simulation for demonstration. This approach was very effective with many decisions made by the committee. In the event the analytical team could not arrive at a decision the alternatives were presented to the program managers.

The assignment of action items was made on the basis of which contractor had the facilities, resources, and experience to do a particular job. In some cases assignments were made on a personal basis rather than on a contractor basis due to the familiarity each contractor had with each others team members. This resulted in the most qualified contractor personnel assigned to perform particular tasks.

Each contractor on the IPCS program identified a "lead engineer" early in the design process. The lead engineer was responsible for the contractor's contribution to the mode design. It would be advisable for the lead engineer to remain on the program through the test phase wherein his tasks would involve coordination and mode design changes. He would be responsible for maintaining a consistent level of design contribution and interfacing with the other contractors. He would also serve to screen communications to avoid confusion.

4.2 ANALYTICAL TOOLS

There are three fundamental tools available to support the intuition and judgement of the controls engineer; simulations, classical stability models, and optimal control theory. The first two were used extensively on the IPCS program. Optimal control is discussed because it was explored briefly on the IPCS program and because it may be relevant to future programs. The material presented in this Section is discussed in substantial detail because the field is developing so rapidly that standardized, generally accepted, techniques have not yet evolved. Hence management guidance may be required in organizing the analytical tasks.

Dynamic simulations of the F-111 propulsion system formed the foundation for the IPCS control system development and software validation. Two types of simulations were generated. The first was an entirely digital simulation developed for a large digital computer such as a CDC 6600. The second was a comprehensive hybrid simulation, based upon the digital simulation that was developed by Honeywell. The following paragraphs describe the simulations used in the IPCS program and make recommendations for future applications.

4.2.1 Digital Simulation

The IPCS digital simulation incorporated most of the system definition data that were available, thus forming a convenient repository for masses of detailed information. Linear state models extracted from the digital simulation were used to study control system stability and response. The digital simulation was the principal test bed for evaluating new control modes.

A good digital simulation satisfies three requirements:

1. It is a comprehensive source of standard information on the steady-state and dynamic characteristics of the plant to be controlled.
2. It is a basis for analytical stability models.
3. It is a test bed for evaluating candidate control features.

The digital transient propulsion system simulation is used for early control design checkout, mode evaluation, gain and compensation selection, and schedule generation. It is used in later development stages to help interpret test results and investigate new development problems. The extent to which it serves these purposes is dependent upon its detail, accuracy and frequency response. To satisfy these usage requirements the propulsion system digital simulation should model the following subsystems:

1. Engine
2. Inlet and relevant portions of the airframe
3. Control system
4. Sensors
5. Actuators

In addition the simulation should make provision for, or include simple aircraft dynamic models to permit studies of flight control related loops - for example autothrottle, buzz suppression, CCV/HIMAT/VTOL flight control systems and inlet distortion control.

The heart of the system simulation is the engine simulation discussed in paragraph 4.2.1.1 below. Successful system development requires integration of the engine simulation with controller, inlet, sensor and actuator simulations. The problems and potential solutions associated with this integration activity are discussed in Section 4.2.1.2.

4.2.1.1 Digital Engine Simulation

The digital engine simulation used for IPCS and for foreseeable engine development programs is a transient engine simulation consistent with the requirements of ARP 1257, with good fidelity for frequencies less than 30 Hz.

The initial digital simulation will be based on predicted engine performance and component characteristics. As component rig tests provide better definitions of component characteristics, the simulation should be updated to reflect these results. This primarily involves refitting compressor and turbine maps from their early estimates to their demonstrated performance levels. Variable geometry and bleed effects on compressor speed-flow, efficiency, and surge line should be included in the simulation as appropriate. Engine match changes resulting from the component testing should also be included in the simulation.

The simulation should eventually predict accurately engine response to changes in all controllable parameters. These include fuel flow, compressor variable geometry, compressor bleeds, compressor face conditions, variable turbine area, afterburner fuel flow and variable exhaust nozzle area. It should also predict engine response over the entire flight envelope (altitude, Mach number), as well as other influences such as service bleed, horsepower extraction, and heat transfer effects. The effects of most of these factors are usually known with sufficient accuracy early in the development process to facilitate control studies. The incorporation of bleed valve dynamics, actuator dynamics, and sensor response characteristics further enhances the usefulness of the simulation, providing refinements to the engine response predictions that permit more accurate assessment of control gains, compensations, and hysteresis.

As development progresses to engine test, component interaction effects are identified, and the simulation must be adjusted accordingly. Interaction effects can be simulated by variable scaling of the compressor and turbine speed-flow and efficiency characteristics. Engine test data also provide the first check on the simulation predictions for transient operation. Heat transfer effects, rotor inertias, and volume distribution can be evaluated by inputting the fuel flow trace measured during the transient and comparing predicted engine response with the measured response. Alternatively a programmable digital controller can automatically generate engine step responses to input variables.

Although the IPCS program began with a fully developed engine, the transient simulation evolved in three phases. The first phase was a SMITE simulation which was developed prior to IPCS conception and was used for early studies. The second phase was conversion to the SOAPP (State-of-the-Art Performance Program) system to improve simulation flexibility and facilitate link-up with the F-111 inlet model. Component maps were also updated during this conversion to provide better agreement with the sea level static production engine data. The third phase consisted of fine tuning component maps to match altitude performance demonstrated by one of the engines assigned to the IPCS program. A comparison of the initial and final simulation predictions with engine test data is shown in Figures 4.2-1 and 4.2-2.

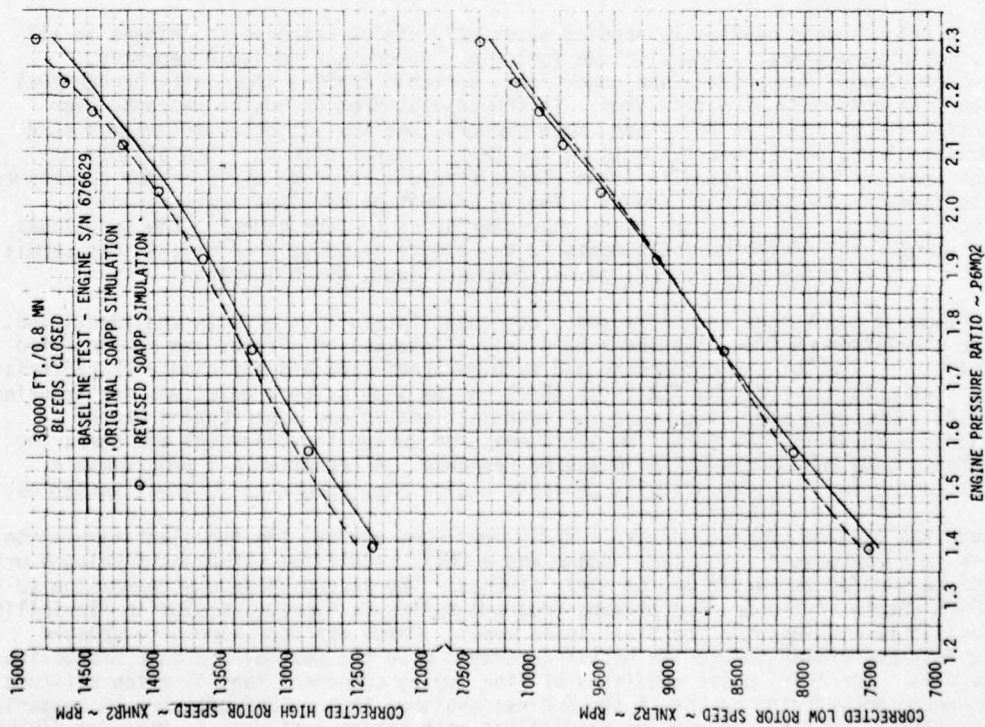

Figure 4.2-1 Estimated Engine Performance

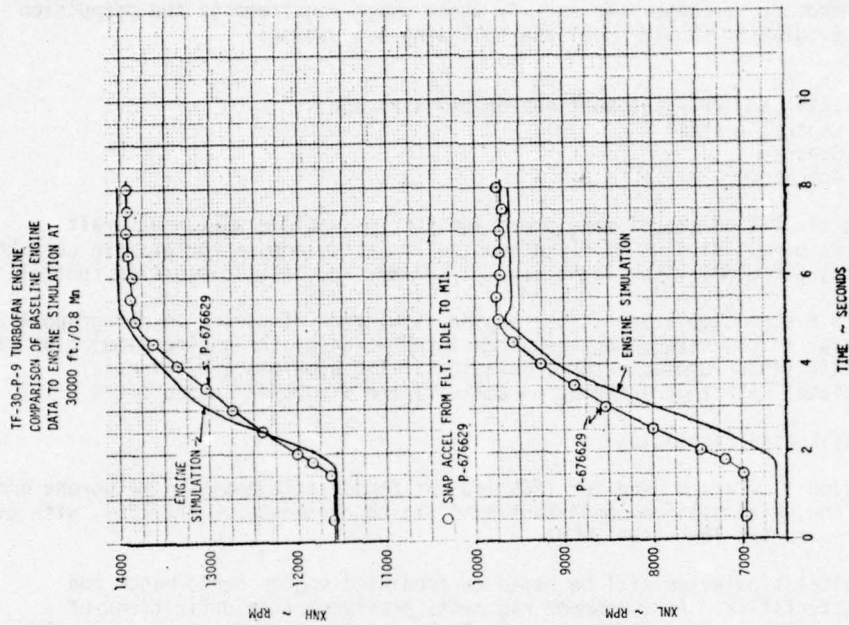

Figure 4.2-2 Comparison of Baseline Engine Data to Engine Simulation

Though continual simulation refinements will ultimately lead to predictions that are ever closer to measured data, there is a trade between the development effort required to achieve high accuracy and the benefits accrued therefrom. If a programmable controller is used during early engine development testing, simulation accuracy becomes less critical because gains, compensations, and schedules can be easily modified. If this control flexibility is not available during early engine development, then simulation accuracy becomes more important in minimizing the number of changes required. In addition, good simulation accuracy in predicting engine operation around the flight envelope can minimize surprises during initial flight testing. The TF30-P-9 engine simulation predictions were predominantly within 3 percent of measured steady state performance.

Engine simulation frequency response requirements depend upon the frequency response of the control parameters. Most of the conventional control parameters such as fuel flow, rotor speeds, and burner pressure are influenced primarily by rotor inertia effects, and a frequency response of 10-20 Hz is adequate. Other control parameters intended to detect and control higher response phenomena such as incipient compressor stall or afterburner rumble require a much higher (50-100 Hz) simulation frequency response. For a development program in which a hybrid simulation is available (Section 4.3), these high frequency phenomena may possibly be implemented in the hybrid simulation if required. Controller response to the signal in question can be verified on the hybrid without a significant increase in simulation complexity by use of a relatively simple simulation intended only to duplicate the input-output characteristics of the phenomena and not its physical processes.

If a requirement exists to study in detail the particular phenomena in question a separate specialized simulation may be required.

4.2.1.2 Inlet Simulation

Computer technology has progressed to the point where fairly detailed and accurate simulations of inlet flowfields are possible. These simulations are, however, expensive in computer time and core space so that the question of the level of detail and fidelity required for propulsion control development must be addressed here. In general, the inlet simulation must be able to predict flow conditions (pressure, temperature, distortion) at the compressor face to support the engine simulation and it must predict control signals well enough to support inlet controls development. (It may also be necessary in some future program to predict the external flowfield to support the development of flight controls, but since that problem was not addressed in the IPCS program, there is no basis for a discussion here).

It appears at this time that a one-dimensional compressible flow model supported by empirical (i.e., test) data is adequate for controls development. A simple two-lump compressible flow model was used on the IPCS program. (A block diagram is shown by Figure 2.2-1, volume II.) The empirical pressure recovery data were biased by a throat Mach number parameter. Simple first order lags applied to the inlet control signals and the two-lump duct volume provided the only simulation of duct dynamics. It should be noted, however, that the inlet control loops were not closed on inlet aerodynamics.

It is possible to make major simplifications in the inlet simulation equations by working with the critical flow area, A^* , rather than Mach number. A simple constant relates A^* to corrected weight flow, i.e., $A^* = .02022 \text{ WAR}^2$ where A^* is given in square feet and WAR^2 is given in pounds per second. The ratio A^*/A (or reciprocal) is a unique continuous function of Mach number, with continuous derivatives in a flow field that is either uniformly subsonic or uniformly supersonic. Thus any function of Mach number may readily be mapped into a function of A^*/A . It is possible to integrate the flow into and out of a control volume but it may be preferable to apply compensation to the model predictions using e.g., the method of Willloh, reference 3 to generate transfer functions.

The simulation of large amplitude disturbances such as inlet start, unstart, or buzz represent a difficulty for a low frequency digital simulation, as do related phenomena (stall, etc.) for the engine. When these phenomena require study in their own right a separate simulation should be provided. For IPCS with a familiar airframe and external compression inlet this was not necessary. Under other circumstances it may be. In any case a crude model of such phenomena should be provided in the hybrid simulation to verify controller logic. The IPCS inlet model could be made to oscillate by programming an artificial recovery curve for airflows below the buzz threshold, so that recovery decreased as airflow decreased. It cannot be claimed, however, that this oscillation represented buzz, or that it approximated buzz better than a sinusoidal or saw-tooth wave form or a duct empty-fill cycle. Nevertheless the closed loop buzz control system response produced by this model was an adequate representation of installed performance, indicating the utility of such crude models in controller design.

4.2.1.3 Digital Simulation Configuration

It is very difficult to define precisely the fidelity and details that must be provided by the digital simulation. Some aspects of this were discussed in earlier paragraphs. The organization of the program, on the other hand, has a strong bearing on its usefulness and the ease and economy with which it can be applied. IPCS experience and recommendations in this area are discussed below.

Most modern large scale engine simulations, including SOAPP, use a predictor-corrector technique that permits the simulation to advance through time in relatively large steps, say 0.1 second. This has two important ramifications. First, there is the obvious limit on the frequency response of the simulation. That has not been a significant limitation to date although it may be a problem with some future engines. The second, and more important consequence follows from the fact that the digital controller uses, typically, a sampling interval shorter than 0.1 second. There is a fundamental incompatibility when a digital subsystem, operating on a short time step, is programmed into a simulation that runs at a longer time step. The most obvious result of this is that the iteration technique will frequently fail to converge when minor changes are made to the control algorithm during the development phase. Furthermore, the control mode, as programmed on the digital simulation, is one step further removed from the flight software. Some of the IPCS contractor personnel feel that there is very strong incentive to run the digital simulation at time steps corresponding to the controller sampling interval.

The cost impact associated with running the simulation at the controller sampling interval cannot be assessed at this time. First of all, simulation computer time is not necessarily directly proportional to the inverse of the simulation interval, halving the simulation interval will not double the computer time. Secondly, most computer accounting methods are set up so that computer time is only a portion of the total charge. Finally, it is not possible to price the impact of running the simulation at time steps other than the sampling interval. The problem was not clearly identified on the IPCS program in time to estimate the cost increment. Thus we can only call attention to the situation at this time and urge that it be addressed from the very start of any future program.

Figure 4.2-3 is a propulsion system digital simulation program configuration that would isolate the various parts of the propulsion system control. This configuration would allow the control algorithm to be contained in one routine and will simplify the mode software definition as discussed below. Separate modules for sensors and actuators will permit ease of handling measurement noise and errors and interface hardware dynamics and simplify maintenance of the simulation.

The control algorithm should resemble the desired flight software configuration as closely as possible. It should use the same equations, in the same order, since the order in which calculations are performed affects the result. Units, sign conventions, and coordinate systems should reflect actual hardware. If, as was the case in IPCS, sign changes and offsets in various servo loops were distributed amongst sensors, actuators, electronics, and software, each element should be represented algebraically even if its dynamics are not significant.

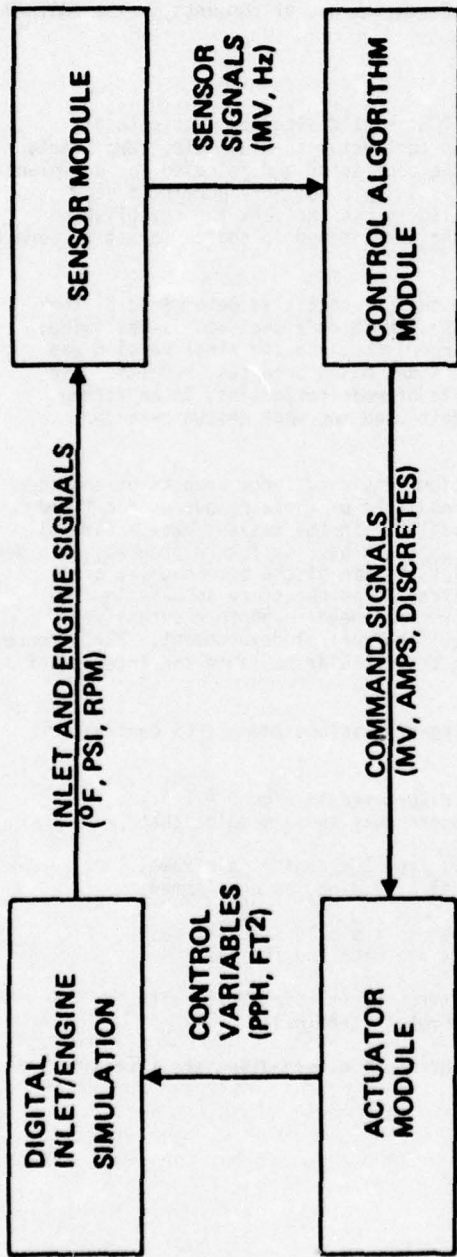

- | | | | |
|----------------|-----------------|--------------------------|--------------------------|
| <u>Modules</u> | <u>Sensors</u> | <u>Control algorithm</u> | <u>Actuators</u> |
| Inlet/engine | Response | Software | Servos |
| Inlet model | Accuracy | Mode algorithm | Servo drivers |
| Engine model | Noise | Control sample time | Rate/position limits |
| Probe effects | Hardware signal | Sensor calibrations | Response characteristics |
| Fuel manifolds | Conditioning | | Hardware signal |
| Nozzle loading | | | Conditioning |

Figure 4.2-3 Digital Propulsion Simulation Configuration

Logic networks should be identical. Techniques used for digital filtering should be identical; if, for example, Tustin's method is used in the flight software, then Tustin's method should be used in the simulation. It should in fact be possible essentially to reproduce the FORTRAN listing of the control module in the document that is used to specify the flight software requirements. This will save a significant amount of labor and will eliminate an important error source. Extensive use of comments in the FORTRAN will further assist in formal documentation.

4.2.1.4 Field Deck Procedure and Alternatives

The design procedure agreed upon at the early IPCS joint design sessions with all contractors was to provide a field deck for each contractor to use. (The term "field deck" refers to a digital program prepared by one contractor and released for out-plant use by other contractors or governmental agencies.) This not only permitted each contractor to evaluate the mode concepts, but also to use the deck for establishing their contribution to the mode design. The decks were issued in source format to permit ease of deck operations to change the mode.

Field decks were issued at various times in the design process as determined by the extent of program changes in effect at P&WA. The BOMDIG mode deck was issued twice, once for definition of the mode for baseline comparisons, and the final version was issued to provide an update of the inlet/engine model based upon test results. The IPCS deck was issued five times at various levels of mode refinement, in an attempt to maintain a level of consistency with the models used for mode design by each contractor.

Issuance of a field deck is an expensive operation requiring large amounts of engineer and programmer manpower and computer time. Expenditure of these resources for field deck operations detracts from those normally available in the design phase. Careful consideration should therefore be given to the approach used in future programs in order to satisfy both budgetary and schedule constraints. Some of the alternatives are presented below. In considering these alternatives it is necessary to bear in mind that both the engine and the airframe manufacturer may need to perform extensive simulation studies for purposes other than propulsion control development. Furthermore, the customer may require access to a simulation on a regular basis in the interest of maintaining visibility and program control.

The following alternatives were identified during discussions among IPCS contractor personnel:

1. Issue field decks in modular form as diagrammed in Figure 4.2-3. Minimize the number of updates and update only those modules that have changed significantly.
2. Co-locate all control designers (i.e., from the engine, airframe, and control manufacturers) at one facility during the development program.
3. Communicate all simulation requirements to a single site (by mail, telecon, telefax, etc.) where the runs are made and the results transmitted back to the sender.
4. Run all simulations on a common computer. Users communicate with this computer via telephone links and remote terminals.

The major advantages and disadvantages of each of these alternatives are listed in Table 4.2-1.

Table 4.2-1 TRADES IN LOGISTICS OF DIGITAL SIMULATION

METHOD	ADVANTAGES	DISADVANTAGES
1. Issue field decks	All users have ready access to simulation on their own computers. Minimum intercompany accounting problems. Decks available for studies other than propulsion control development.	Expense and inconvenience of preparing field decks and educating users.
2. Colocate designers	Minimum computer expense Close communication between engine/airframe/control manufacturers and control designers.	"Outplant" personnel lose contact with their home organizations. Difficult to maintain continuity of personnel. Possible personnel problems. Travel and maintenance expense. Simulation not generally available for other uses.
3. Communicate requirements to single site	Minimum computer usage	Serious communication problems. Long turn-around times. Tendency to skimp on simulation studies
4. Remote terminal to single computer	Ready access as in 1.	Expense of terminal and phone link.

4.2.2 Hybrid Simulation

4.2.2.1 Use of Hybrid Simulations for Propulsion Control Development

The main tool for control studies at Honeywell was the non-linear engine simulation using the hybrid computer. This simulation was driven in two modes, 10-to-1 slow time with the control algorithms programmed in FORTRAN on a SIGMA V computer and a real-time mode with the assembly language control algorithms programmed on the actual digital computer to be used in flight. There was a very large step involved in going from the FORTRAN to the DAP-16 assembly language used in the real-time program. For example, the FORTRAN program did not address the I/O problems associated with actual sensors and actuators. An evaluation of memory and computing speed requirements based on the FORTRAN listing would have given erroneous answers. Individual compensation and functions used to obtain better accuracy and scaling of both sensors and output commands used up more resources than generally expected.

The slow-time FORTRAN simulation was used at Honeywell to study sample time effects. The results of one of these studies are shown in Figure 4.2-4. One of the interesting conclusions was that care should be used in implementing block diagrams drawn by persons unfamiliar with digital control requirements. Difficulty in the BOMDIG development was encountered when block diagrams describing logical operations were drawn in arithmetic form and combinations of logical and arithmetical statements were used in the generated program.

The sample times -- both for the major sample and the minor sample times (a multiple of five milliseconds) -- shown to be adequate for BOMDIG and IPCS were then used when programming and studying control behavior in real-time.

The hybrid facility was used jointly by two programs on a day-to-day basis, the IPCS program and the Space Shuttle Main Engine Control program. About one-half hour was required to change over from one simulation to the other. Once set up, a flight condition could be changed in about 10 minutes by simply loading in a deck of cards which defined the new pressure and temperature conditions and initialized the engine at the new conditions. Real to slow-time transition was obtained by simply throwing one switch which simultaneously changed all the capacitor values on the integrators.

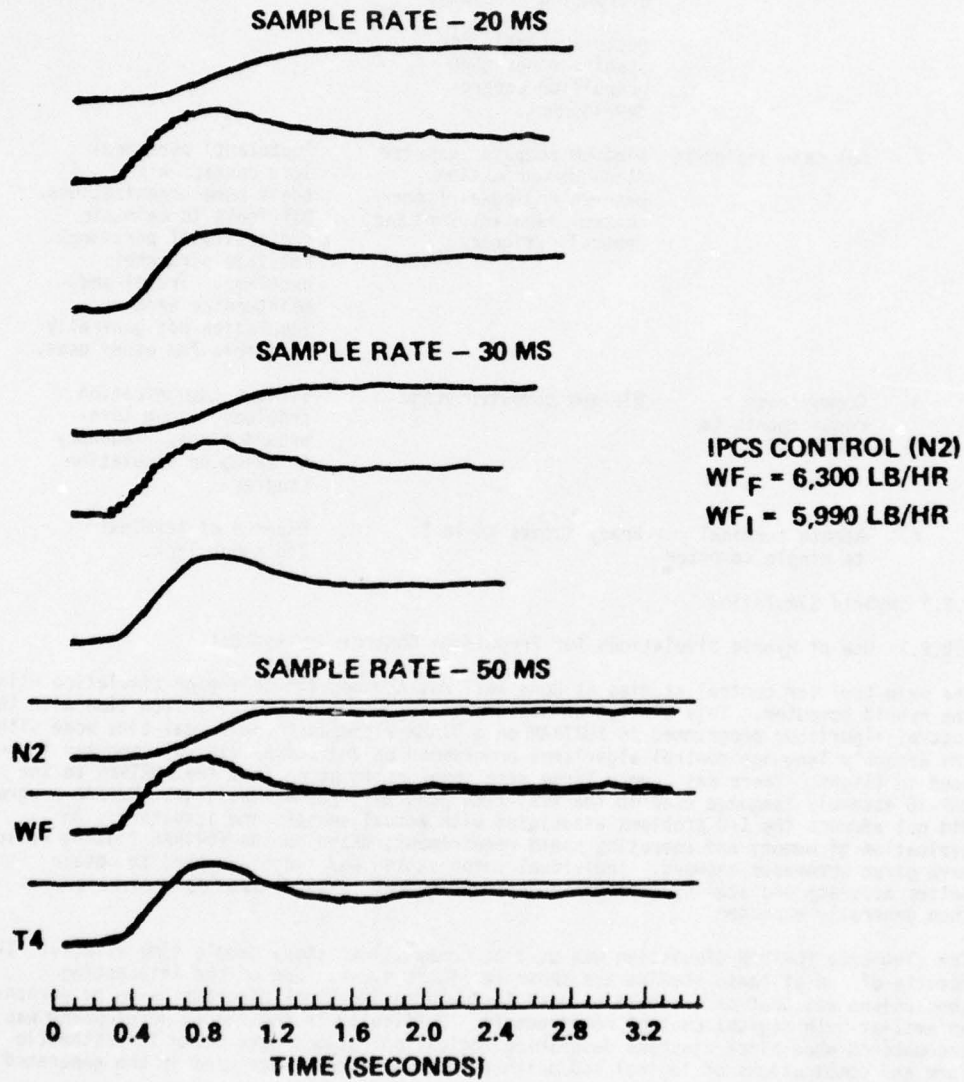

Figure 4.2-4 Sample Rate Studies

The non-linear hybrid engine simulation was set up in terms of "corrected" or generalized parameters. This was required for the compressor because a supersonic inlet delivered a variable compressor face total pressure but in addition, the flexibility provided by the generalized maps used allowed flight conditions to be changed quickly.

All of the integrators were in the analog portion of the hybrid and so were not affected significantly by the computing speed of the digital part of the hybrid. This digital part of the simulation was used for compressor map functional generation as well as for those other non-linear engine relationships requiring complex functional descriptions. Computing time was on the order of five milliseconds to complete all required calculations. A rough rule of thumb is that six to eight "points" are required to define a sine wave. At a five millisecond sample time this indicates that the Honeywell hybrid simulation may be used for control studies in the frequency range to 25 Hz. Good frequency response is particularly required in the study and evaluation of engine control loops such as turbine inlet temperature, compressor discharge pressure and Mach number and A/B phenomena affecting engine back pressure. Also, the switching characteristics when going from one control mode to another may be regarded as a high frequency problem in that precise definition of the time when switching should occur requires a good high frequency engine definition. This was particularly noticeable in the IPCS program where a complete low frequency digital simulation of a suggested control change indicated behavior that was not attainable when the change was actually implemented on the aircraft.

The hybrid simulation proved invaluable in two major areas -- it allowed many hours of software "debug" time in an actual real time environment and it provided the only tool to study some destabilizing control aspects not evaluated anywhere else. The all-digital simulation did not, for instance, simulate the stepper motor used in the exhaust nozzle controller. This motor could drive at the rate of 15 steps/30 milliseconds and so, therefore, could drive for half a sample period and stop part way through the period. The proper control configuration for this loop was evaluated on the hybrid. It could have been also on a complete digital simulation by using much finer time increments. The cost of the digital simulations would have increased very significantly.

The many hours of software debug time provided by the hybrid allowed many of the coding problems such as overflow, scaling errors, plain coding errors and dynamic compensation problems to be corrected before they became expensive. This was a significant contribution in saving of time and expense during the bench, wind tunnel and flight phases of the program.

In any future programs, many hours of software "debug" time against a real time engine simulation will prove invaluable in both cost and time when considered against the alternatives of later schedule impact due to ill-defined software configurations. Such studies will be particularly important in production programs where large margins in memory and computing speed may not be available and I/O skew problems may be much more significant.

The actual real time computer program was evaluated on the hybrid computer at four flight conditions. These were sea level static; 0.9 Mach, 45,000 feet altitude; 1.6 Mach, 45,000 feet altitude; and 2.1 Mach, 45,000 feet altitude. The rationale for this choice of conditions is as follows: Conditions of constant total pressure at the compressor face may be imposed at given points in an aircraft flight envelope if the supersonic inlet is assumed operating at its design condition. This pressure is the primary forcing function in determining the pole-zero location of the engine characteristics. The pole-zero locations are affected only in a relatively minor way by compressor face total temperature. Hence checking the engine at the above four flight conditions can be interpreted as a check of many other flight conditions also, i.e., those with the same compressor face total pressure. Sea level static is used because most of the initial engine running is done at that condition, 0.9 Mach because this is perhaps the minimum total pressure to be encountered, 2.1 because this is both a supersonic inlet operating condition as well as a maximum or large total pressure condition and 1.6 Mach as a median case for which the inlet surfaces were also modulated in flight.

As stated in Volume II the IPCS program was designed to be a conservative, success oriented program. Therefore, control development paths were followed which were known to be successful and would, therefore, contribute to a minimum of program extensions during the expensive phases of the bench and engine test program. As a matter of fact, the test programs in these phases were shortened from those originally planned. This reduction was possible only because of the thorough software verification process conducted in the non-expensive areas of the program -- when bench, engine, wind tunnel, and flight test facilities were not impacting the costs.

4.2.2.2 Real Time Plant Simulation (RTPS) Recommendations

As discussed above, some form of real time plant simulation is essential for in-house checkout and development of controller hardware and software. The same simulation capability is necessary for closed loop bench testing. Finally the RTPS is required at each engine test site to verify software and troubleshoot controller problems with a minimum of engine run time. This leads to the conclusion that the RTPS, in addition to being a detailed real time simulation, should be portable and configured to permit rapid substitution of it for the engine or elements thereof. The following paragraphs define the RTPS requirements based on IPCS experience, and present a basic simulation configuration.

The RTPS performs three functions:

- 1) Provides closure of all control loops associated with the controller,
- 2) Facilitates study of conditions and phenomena not feasible with other simulations - start, buzz, rumble, failure modes, finite word length and interface effects
- 3) Provides test crew training in troubleshooting and hands-on experience with real time operation of the control system hardware and software.

During the early part of a development program these functions permit development of controller hardware design in a relatively efficient manner and independent verification of controller design and digital simulation performance early in the design process. Later the RTPS, its configuration stabilized, provides an indispensable tool for software checkout and troubleshooting.

In order to perform the above functions, the RTPS must meet various requirements.

In those areas where comparison is possible the RTPS must accurately replicate the large scale digital engine simulation. The degree of accuracy required is best expressed qualitatively - if the controller must be changed to accommodate the RTPS or if the RTPS tends to become a scape-goat for system problems it is inadequate. Techniques for conversion of large scale digital simulations to equations suitable for RTPS use are currently being developed at P&WA. Since these techniques are automated they promise to be superior to developing a separate RTPS math model from first principles. Caution should be exercised in their use, however, since they will tend to eliminate the inherent double check provided by an independent simulation.

The RTPS should represent all phenomena that the controller is designed to sense or control. Problems were found in the field in most control functions not thoroughly checked by simulated closed loop operation - buzz and stall are examples. These representations need not be terribly precise - cases must be considered on their own merits. As a rule of thumb, one should remember that any reasonable controller should tolerate at least 2:1 gain variation in the forward loop; hence the plant simulation, if only critical for functional checkout, need only be this good.

The RTPS must be portable and adaptable to use in various test facilities. This implies use of current technology in implementing it. Current technology will also provide more repeatable, reliable operation and simpler interfaces. Portability and adaptability are essential to permit use of one simulation for all field support activities, reducing development costs and repeatability problems.

Those sections of the simulation representing engine performance and fixed system elements should be subject to good configuration control in the field. This is essential to provide repeatable simulation results. However, plentiful accessible spare capacity should be provided in the RTPS to meet unanticipated simulation requirements.

Finally, one person, preferably one of the developers of the RTPS should be assigned to provide field support of the RTPS throughout the test program. This is essential if the RTPS is to provide the continuous reliable support required of it.

The simulation should have the configuration shown in Figure 4.2-5. The Actuator Simulation Section provides detailed simulation of controller loads, actuator dynamics, and actuator servo loop closure feedback signals. Where cost effective, actual hardware may be incorporated in this section. The output of the Actuator Simulation Section is a set of scaled plant input variables - fuel flows, bleed states, etc. The engine and inlet simulation are implemented electronically in a manner permitting simulation of phenomena over the entire range of frequencies expected in and of interest in the plant. Noise generators may be incorporated where appropriate.

The Sensor Simulation Section converts scaled variables output by the Engine/Inlet simulation to simulated transducer outputs.

The RTPS is constructed to permit interfacing with flow bench hardware by breaking connectors at the interface between the Engine/Inlet Simulation and the I/O sections. By making this simulation an integral part of the Propulsion System Test Equipment program costs and schedules will be reduced since the simulation will be available for use at all times. Thus software field changes may be checked out quickly on-site without incurring engine or bench user time penalties and the risk of damage to engine hardware through software errors.

Spare capacity is provided in each section of the simulation to permit adding details or new elements to the simulation. Depending on the scope of the controller, the RTPS may incorporate additional features - aircraft rigid body dynamics for example. The dedicated parts of the RTPS should be fully defined and checked out prior to Bench Test. Thus the entire unit can come under rigid configuration control when it leaves the vendors plant. This will assure a consistent documented simulation throughout the remainder of the development program.

4.2.3 Stability Models

Gas turbine engines are notoriously non-linear. Most of the discontinuities, however, occur at operating boundaries, so that the engine may be considered piecewise linear over much of its operating envelope. The designer has several options. He may elect to represent the controller as a set of single-input, single-output loops and apply root-locus or other standard linear methods. Alternatively, it may be possible to estimate values of gain and the form of compensation that will give satisfactory performance. A simplified simulation may be set up to evaluate these by stepping through a range of gains, time constants, etc., comparing the system response to standard disturbances. Combinations of these techniques have been used successfully in many situations.

The rapidly developing science of optimal control theory offers a third alternative that may eventually be far superior to the others. This technique optimizes multiple input, multiple output systems to predetermined criteria that are programmed on the computer. The constraints of single-input, single-output loops are eliminated, the process is highly automated, and the computer applies the optimization criteria consistently.

4.2.3.1 Extraction of Linear State Models

Linear state models are extracted from the SOAPP simulation via perturbation techniques. (See Appendix to Vol II.) These procedures have progressed, reducing time and manpower required for model extraction, such that special subroutines for the purpose are compiled with the non-linear digital model of the propulsion system and automatically provide linearized models at the operating point of interest upon request.

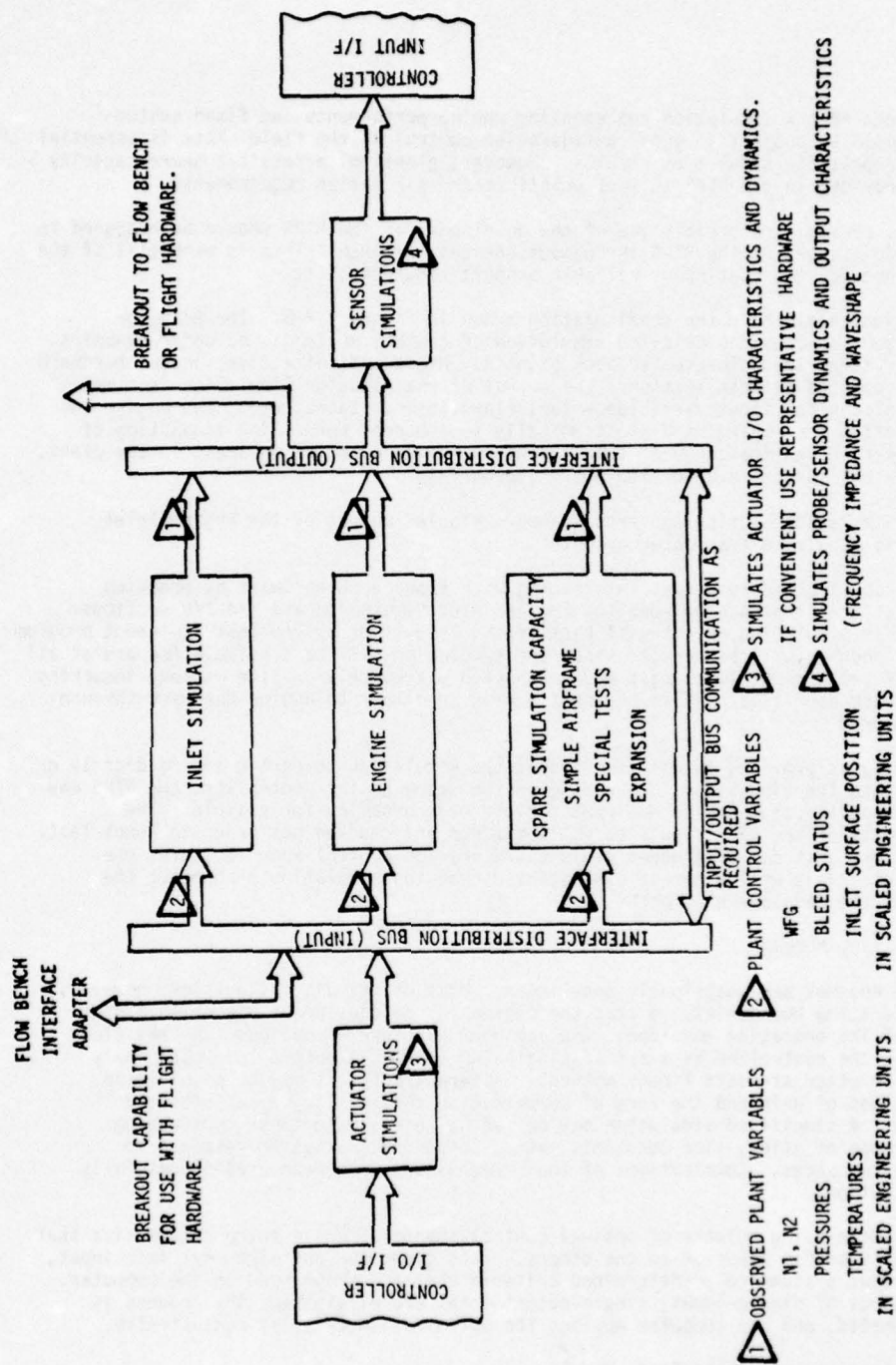

Figure 4.2-5 Real-Time Plant Simulation Configuration

4.2.3.2 Transfer Function Generation Techniques

Having found the system matrices by perturbation techniques transfer functions are obtained using State Variable Techniques. The state variable representation of a linear system consists of the following two Matrix equations:

$$\begin{aligned}\dot{X} &= A X + B U \\ Y &= C X + D U\end{aligned}$$

where X is the vector of state variables such as pressures and rotor speeds, U is the vector of control inputs such as fuel flow, and Y is the vector of observed parameters such as airflow and Mach numbers. The plant matrix, A , and its elements are the partials from each state variable to each state variable time derivative. The control matrix, B , defines the effect of each control input on each state variable time derivative. The output matrix, C , defines the relationship between the observed parameters and the state variables, and the output matrix, D , defines the relationship between the observed parameters and the control input, U .

The above equations are manipulated using Matrix operations, and substituting the Laplace operator "S" for time derivatives results in the following equation for transfer functions:

$$G(S) = \frac{Y}{U} = C(SI-A)^{-1}B+D; \quad \frac{X}{U} = (SI-A)^{-1}B$$

where I is the Identity Matrix.

The state variable technique for extracting transfer functions from the non-linear model has been found to be the most cost effective and accurate procedure to date.

The chief computational problem is in the calculation of $(SI-A)^{-1}$ for high order systems. The form of $(SI-A)^{-1}$ is that of a rational function consisting of a matrix polynomial numerator defining all possible transfer function numerators and a scalar polynomial denominator which is the characteristic polynomial of the A matrix. Clearly the roots of this characteristic polynomial are the eigenvalues of the A -matrix and also are the poles of the system transfer functions.

Methods such as Leveriers Algorithm (4) attempt to compute $(SI-A)^{-1}$ in its entirety by the use of high powers on the A -matrix which is not numerically sound. In addition the characteristic polynomial is formed and rooted for the poles - again a numerically unsound procedure for high order systems.

The best technique is to obtain the eigenvalues of A by the QR transformation (5), multiply the eigenvalues together to form the characteristic polynomial and then use a more modern method for the numerators (6), (7) which only attempt to produce a single transfer function numerator at a time.

The method of Patel (6) is easily coded and requires the determination of two matrix characteristic polynomials, the desired transfer function numerator polynomial then being found as the difference between the two characteristic polynomials. Provided sufficient precision is retained in the polynomial coefficients by working via eigenvalues, the method is numerically sound.

The method due to Davison (7) appears to be numerically sound but somewhat more difficult to use since it determines transfer function zeros as the eigenvalues of a specially constructed matrix, which do not tend to infinity as certain constants within the matrix change value.

Thus the program is required to partition the matrix eigenvalues into two groups, one tending to infinity, the other remaining substantially constant. The constant group are the desired zeros.

Both methods are practical, the difference is mainly one of convenience.

4.2.3.3 Selecting the State Variables

The correct selection of the state variables is necessary to result in transfer functions that contain meaningful frequency content. Minimizing the number of states will also serve to simplify the data and minimize processing cost.

For linear model generation, the following factors should be considered to arrive at the minimum order model possible:

States with dynamics more than one decade higher in frequency than the frequency range of interest are usually ignored.

Frequency range of interest should be determined from sensor and actuator response characteristics. In other words if it is desired to control some high response state but available sensor and actuator responses are not fast enough to "sense and control" these states, there is little incentive to include these states in the linear model.

Other states with slower response can also be eliminated, but the validity of doing this must be evaluated on the nonlinear model - i.e., evaluate impact on resultant closed loop performance - and also eliminate states associated with low frequency poles which are nearly cancelled by zeros (such as heat storage states) since these will have little impact on closed loop response.

The number of states in the simplified linear model must be no less than the number of desired isochronous control loops; i.e., the model must have as many degrees of freedom as there are independent integral control loops. This may require including some states associated with higher frequency dynamics.

The most general way to generate a linear model is to generate the full state model and then use a modal analysis procedure in which system eigenvalues are calculated, and a set of eigenvalues are selected for elimination from which the appropriate states to be eliminated can be back calculated.

The number of states should be agreed upon by the design team before the design process gets to the gain and compensation design phase. Models with a minimum number of states consistent with the above criteria should be selected. This will avoid the time consuming process of inverting higher order state matrices (SI-A), saving manpower and computer time required to process the data.

It is recommended that the extraction of linear models be performed in a continuous operation at one contractor location. The preferred location would be the one with the greatest expertise in operating the non-linear propulsion system model and the associated model extraction subroutines. This will avoid the unnecessary transmittal of perturbation data and lost time associated with dividing the process among contractors.

4.2.3.4 Classical Operations on Linear Models

Classical methods of control analysis were applied successfully during the IPCS program. The procedure used is as follows:

- Generate linear state models at a series of operating conditions.
- Compute transfer functions from the linear state models.
- Construct a series of point designs, using root-locus, Bode or other recognized methods.
- Program schedules of gains and time constants as functions of characteristic, unifying operating variables. (PS3 was used)

The following criteria were adopted as goals to be used in controller compensation design:

- The gain margin of all loops shall be at least 6 dB.
- Loops designated as limiting (maximum or minimum) shall have no overshoot when subjected to a step input.
- Overshoot, where permitted, shall not exceed the value attained under BOM control as predicted by the SOAPP simulation.
- Rise time of each loop shall be as fast as the value attained under BOM control.
- Settling time of variables shall not exceed that of the BOM control as predicted by the SOAPP simulation.

Candidate designs were tested over the operating envelope using the SOAPP simulation and adjusted as necessary.

The resulting controller was used with few modifications through the entire test program and provided acceptable results. However, more specific design criteria and closer review of early test data would have benefitted the IPCS program.

Based on IPCS experience, the anticipated controller performance should be formally documented as a part of the contract Interface Control Document (ICD) or other specification. The anticipated performance should be defined in terms of the parameters presented above - loop gain, margin, etc. - and in addition allowable steady-state tracking error for each loop should be established. Where appropriate, for example, gain margin and steady-state error budgets documenting tolerance allowances should be included. Formal documentation of these data provides a number of benefits:

1. Organizes the design/analysis process around a focal point.
2. Provides all program management customer and contractor, with visibility of system performance.
3. Provides a reference to which test data are compared - problems are more quickly identified and resolved.

The anticipated controller performance is not intended to be a contractual requirement. Thus as testing progresses and it is found to be unnecessarily tight in some areas and too loose in others it should be adjusted based on a consensus of engineering judgement without contractual implications.

Controller design and modification using an engine simulation are practical only if the engine simulation adequately represents the engine. A portion of the anticipated controller performance documentation should define simulation requirements related to specific control parameters of interest. As early as possible in the test program, compliance with these requirements should be documented. Where a programmable digital controller is available, simulation fidelity is relatively easy to check since the controller can provide clean programmed fuel flow inputs to the engine; the response is easily evaluated on the digital simulation.

4.2.4 Application of Optimal Control Theory

Optimal Control Theory has been applied to design of propulsion system controls to verify suitability of the technique as a viable design tool. Confidence has been established that certain techniques may be used as design tools for future control mode study efforts. These techniques are:

1. Linear Quadratic Synthesis (LQS), and
2. Non-linear Trajectory Optimization

Because of the complexity of the calculations performed, these design tools are applied in an off-line fashion, using computer simulation of the propulsion system to determine the control mode and values of loop gains and compensation. Generalized computer programs now exist for performing these analyses. LQS can be applied efficiently to the design of small perturbation and regulator controls for either single-input, single-output, or multi-input, multi-output systems. The nonlinear trajectory optimization technique can be applied to optimizing large perturbation transients with the resulting transients on engine and control variables used to determine the best way to schedule the transient references for the regulator control.

Also, the nonlinear technique can be applied to the optimization of gains of a preselected control mode structure or to the reoptimization of LQS derived feedback gains in the event that important gain terms have to be abandoned due to such problems as inability to sense the required engine variable for the feedback loop.

4.2.4.1 Non-Linear Trajectory Optimization

The non-linear optimization program requires a non-linear simulation of the plant being controlled, a set of nominal system input trajectories, a set of system constraints, and a performance index. The system inputs are put into the program by breaking down their trajectories into a time series (optimization intervals) and specifying the value at the end of each interval. A modified conjugate gradient technique is then used to calculate direction of movement of each input over each optimization interval to improve the performance index. Supplementary limiting calculations allow the system to move only along feasible directions, which result in performance improvement without violating system constraints. The results of this calculation are open-loop optimal trajectories on the system input that provide optimum performance.

The non-linear optimization program was not used as a basis for control mode design during the IPCS program, but was applied to selected transient control problems to demonstrate applicability to the mode design process. Optimization was demonstrated of the trajectories on main burner fuel flow (WF) and exhaust nozzle area (AJ) to obtain improved thrust response for a gross acceleration at sea level static conditions. Trajectories were optimized on WF, AJ, inlet spike position and second cone angle to obtain improved thrust response and distortion margin for an angle of attack and engine power transient at one supersonic flight condition. Optimization of the integral gain and lead time constant for the high compressor discharge mach number loop of the IPCS control mode was also demonstrated for a gross acceleration at sea level static conditions. In all cases, the results obtained were similar to those obtained with the classical analysis procedure. The key benefit is that the nonlinear optimization technique accommodates loop interaction effects and is less dependent than the classical approach on a trial-and-error process and intuition of the control engineer. This, in addition to the application of the technique to gross transient optimization of other propulsion systems has established confidence in this technique as a tool to be used routinely in the control mode design process.

4.2.4.2 Linear Quadratic Synthesis

The linear quadratic synthesis program is based upon the piecewise linear/piecewise optimal design technique developed at the United Technology Research Center. This technique requires the linearization of the engine simulation and the solution of the Matrix Riccati equation, for a specified performance index, at selected operating points to determine the gains for a feedback controller. Closed loop operation with these gains is then evaluated on the non-linear engine simulation to determine if the desired performance is obtained, and if not, the gains are recalculated with an appropriately modified performance index.

The linear quadratic synthesis technique (LQS) design tool cannot be used to optimize a gross transient response of a non-linear system directly. This may seem like a very obvious statement, however, there has been a great deal of misunderstanding about just how powerful LQS can be for engine control design. LQS determines a set of feedback gains to provide good regulation and small perturbation response about a specified set point. It does not define how to schedule these set points either in the steady or transient state. Thus, during a gross transient, the LQS derived control mode regulates to these transient set points, but it is really the transient motion of these set points that determines the gross transient performance. Some other technique, such as the nonlinear trajectory optimization technique must be used to determine how best to move these set points to obtain the desired gross transient performance.

Because this technique was in its infancy, it was not applied to design of the IPCS control mode. Since that time, however, studies of application of this technique to other propulsion systems have established confidence in the linear quadratic synthesis technique as an efficient design tool to be included as an important element of the overall control design process.

5.0 SOFTWARE DEVELOPMENT

5.1 DEVELOPMENT PROCESS

The IPCS software development process proceeded in an orderly and systematic manner through the establishment and maintenance of design specifications. The functional interface and performance requirements were established in the form of a Design Specification, Part I (see paragraph 5.2). That document establishes the design requirements baseline for the design and qualification testing of each computer program. The preliminary and detailed design are documented via the preparation of a Design Specification, Part II. That document contains narrative and graphical information describing the computer program information and process flow.

The development process was initiated by defining the program's functional interface and performance requirements in the Part I specification. Subsequently, the design proceeded in two phases; the preliminary design and the detailed design phases.

During the preliminary design phase, the individual computer program components (CPCs) were identified. The various functional requirements set forth in the Part I specification were then allocated among the CPCs. The CPCs were selected based upon the similarity of the BOMDIG and IPCS requirements such that most of the design and code developed for BOMDIG could also be applied to IPCS. Four CPCs were identified, Executive CPC, Sensor Processing CPC, Output Processing CPC, and Control CPC. The first three remain essentially unchanged between the two programs. The Control CPC, which provides the control algorithms, is, of course, significantly different. This approach is recommended even if only one set of control laws is being developed. Isolation of the control law permits deferral of control law implementation until the design, code and debug of the other functions are completed, permitting additional time for control law refinement and cost effective update of the control algorithms through the various test phases.

A preliminary design review was conducted subsequent to completion of preliminary design. Due to the time available and the make-up of the design review audience, the review consisted of a presentation to show evidence of technical progress rather than a review as such. Although this, in retrospect, proved acceptable due to the R&D nature of the program, a more detailed investigation would seem appropriate for a production configuration.

Subsequent to preliminary design, the detailed design phase was entered. The Part II specification was completed during this phase providing a detailed description of the computer program data base and a detailed description of each CPC including information and process flow. This information was provided to the level of detail to commence coding.

Test procedures were also prepared during this period. The procedures were divided into three categories. The first of these focused attention on those requirements which could be verified on a stand-alone computer facility without flight hardware. The second focused attention on those requirements which could be verified only using the flight hardware. The last category involved use of the flight hardware and propulsion module simulation and exercised the software over a pre-defined set of flight conditions. The first two categories proved useful during software debug, even though the schedule did not permit completion of all the planned tests. In general, features such as schedules and compensation networks should be evaluated in open-loop tests. It is recommended that other verification be performed exclusively with the controller hardware and ground-support equipment.

A critical design review was conducted subsequent to completion of detailed design. This review was similar to the preliminary design review and the same remarks apply.

The programming phase consisted of three activities; namely, coding, informal testing (often referred to as debug) and CPC integration.

Finally, the verification test phase was entered and completed prior to the beginning of bench tests.

5.2 SOFTWARE CONFIGURATION CONTROL

Proper configuration management and control is an essential element in the successful pursuit of any computer program design and development effort. Without proper control, software flexibility can destroy what might otherwise be a well-managed effort. On the other hand, the change procedure must not be so ponderous that it is an unnecessary burden.

During software development, the specifications were placed under the direct control of the software project engineer. Prior to verification testing, the specifications and the computer programs were released to the configuration control of the technical Program Manager. Release of the computer program listing is a necessary pre-requisite for verification testing.

5.3 DOCUMENTATION OF REQUIREMENTS

Software design-to and test-to requirements are delineated in two specifications; one for each of the programs, BOMDIG and IPCS. These specifications have a format and content compatible with MIL-STD-583. These specifications were prepared using a magnetic tape system which significantly reduced the clerical effort and turn-around time for specification change updates.

The information contained in these specifications was obtained from several sources since the requirements imposed on software typically arise from several sources. The control algorithms were taken largely from the Boeing/Honeywell ICD supplemented, when necessary, by coordination memos. Detail information concerning the interface between the software and the DCU, IFU, sensors, actuators, etc. was taken largely from Honeywell hardware specifications being prepared in parallel. Preparation, release to configuration control and maintenance of these two specifications, their format and their content served this program well and are recommended for other programs. One improvement would have been to include the block diagrams describing the IPCS control laws in the IPCS software specification in addition to the control equations. A FORTRAN listing of the control laws programmed for the digital simulation as discussed in Section 4.2.1 is an acceptable means of documenting the control equations.

The control algorithms for BOMDIG were described in the ICD via block diagrams. The control algorithms for IPCS were described via block diagrams and via a sequence of FORTRAN statements. Those FORTRAN statements and their sequence were obtained as a by-product of the algorithm development activity.

Block diagrams represent an analog model of a physical system in which processes are carried out over a continuum in parallel with other processes. This model must then be translated into a digital model (flow chart) in which the processes are carried out within a discrete set and in a specific sequence. That translation is not one-to-one and there exists the attendant risk of increased cost and schedule to obtain a digital model having acceptable performance characteristics.

The IPCS control was defined using both models. The digital model was used directly to establish the software requirements. The analog model served to clarify the operations being performed and provide insight into dynamic behavior necessary to establish digital scale factors and debug and test the software subsequent to coding.

The use of the digital model to define the control algorithms permits a longer algorithm development period since the time required subsequently to code and test the digital model is considerably less than that for an analog model. Definition of the digital model in FORTRAN is not necessary, but the language should be one widely known and/or easily readable and understandable without ambiguities.

Ideally, the control law algorithms should be developed, communicated and controller-implemented in a high-order language easily understood by all personnel involved in controller development. The choice of language is difficult. The language should be one which can be efficiently implemented in the controller computer (including ROM configurations) to reduce recurring costs and should provide for word length and process time adjustments when run on the algorithm development computer facility. These requirements immediately rule out the use of FORTRAN. The choice will typically involve some level of compiler and/or language development depending upon the state-of-the-art and/or availability of compilers existing at the time the decision must be made in order to obtain a timely analysis of cost effectiveness.

If such a language is not or cannot be made available, the approach used on IPCS is recommended; FORTRAN as a development and communication language and assembly language for controller implementation.

5.4 RESOURCE UTILIZATION

5.4.1 Memory Size and Process Time

The initial concepts of the control algorithms and implementation were used to establish initial estimates of the memory size and process time required. These initial estimates were low, but enough capacity had been provided to meet all program goals.

The initial low estimates were without significant penalty only because the hardware design was based upon a recognition of the R&D nature of the program. The primary benefiting factors were a full 16K of memory and the 5 msec sample interrupt design (which permitted a later necessary 50% extension of the IPCS sample period). Had this been a production program with the attendant emphasis on recurring per-unit costs, the requirement to match computer capability to system requirements would be much more stringent. About six months into the program, the control laws were sufficiently defined and the hardware design was sufficiently far along to warrant a new estimate. At this point, the inadequacy of the initial concept became apparent. As a result the emphasis of software design switched from conservation of both resources to that of process time alone and the sample interval for IPCS was increased from 20 to 30 milliseconds.

Subsequently, software design concentrated on the development of the BOMDIG program (which is identical to the IPCS program except for the control laws and the difference in sample period) while the analysts concentrated on refining the IPCS control laws for later implementation in software. Near the end of this period, that is, once the final control algorithms were selected, the resource requirements for IPCS were again estimated. The result was that a concentrated effort was necessary to condense the control laws, primarily in the number of data points used to describe the various univariate and bivariate functions. This effort was successful and over a thousand data points were deleted without adverse effect on control performance.

The impact on cost and schedule would have been significant if the reduction could not have been achieved without basic modifications of the then-existing control concepts. Control designers must keep in mind that the control must not only be physically realizable, but must be realizable within the resources available. It is recommended that memory size and process time be more frequently projected with budgets established for growth during bench, SLS, altitude and flight tests. Furthermore, these projections should be closely monitored to the extent that potential problems can be identified and resolved before they can cause cost/schedule impact.

5.4.2 Word Length

The dynamic range and precision of control variables within the digital computer are limited by the computer word length. A cursory analysis, prior to selection of the HDC-601, indicated that a 16 bit word length would be sufficient. The double-precision (31 bits) arithmetic available in the HDC-601 could be used to gain additional range or precision is necessary. It proved to be unnecessary except in the gas generator fuel command (isochronous governor) integrator.

Care was taken during the detailed software design to scale all data, using fixed-point binary scale factors, to achieve maximum precision based solely upon needed range (maximum magnitude expected). Problems were expected since the control laws were being developed in parallel using FORTRAN having significantly greater precision and, for all practical purposes, infinite range.

Only one problem was encountered. Control law analysts specified large constant values in the IPCS loop select logic which gave rise to an inability to select the proper loop due to insufficient precision. However the large constants were in fact arbitrary and were subsequently rescaled (from 10,000 to 31, for example) to accommodate both range and precision within the 16 bit word.

5.5 SOFTWARE TESTING

Software testing proceeded in three phases as follows:

- 1) Informal or debug phase
- 2) Verification phase
- 3) Category II test phase

The informal or debug phase was the last step in the software implementation process to prepare the software for verification. The software was not under configuration control during debug to facilitate handling the large number of anticipated changes in a cost effective manner.

However, the software was placed under configuration control during verification testing. This was necessary since it is the intent of verification testing to establish assurance that the software being delivered meets its requirements. Hence, the configuration must be identified and controlled so to relate the configuration(s) tested to that delivered.

As indicated in paragraph 5.1, the verification tests for BOMDIG and IPCS were divided into three categories. This division was made with the thought that some verification could be performed prior to the availability of the flight hardware. In retrospect, this was not cost effective and did not contribute to an intended schedule pull-in. It is recommended that verification testing be performed exclusively with flight hardware and ground support equipment with all closed-loop control performance testing performed against a real-time dynamic simulation of the propulsion module.

Verification testing included control of the simulated propulsion module at various flight conditions. Key simulation performance parameters were recorded on a graphic plotter and compared against those recorded earlier using a FORTRAN control algorithm model at the same conditions. This proved extremely beneficial since it afforded performance verification in a closed-loop dynamic environment closely simulating the expected flight environment. It is recommended that this type of testing be the main thrust of future verification efforts supplemented by specific open-loop tests for those functions for which the simulation does not provide an acceptable environment.

The bench tests at East Hartford provided further software verification implicit in the system level test. Indeed, the bench tests did provide an environment different than that provided by the hybrid simulation.

Due to the lack of time between the availability of the flight hardware and its shipment for bench tests, software verification focused primarily on those functions for which the simulation was best suited. As a consequence, some problems remained to be uncovered during bench test. Some level of dependence on the use of the bench test facility for software verification seems appropriate as will be discussed in Section 7.0 of this document.

5.6 FIELD SUPPORT

Except for two or three errors uncovered during the early bench testing, all software field changes reflected changes in software requirements. This was not unusual and can be expected. The flexibility afforded by a digital system is clearly a significant factor in the cost-effective development of a controller for either a new or existing engine.

On IPCS, changes subsequent to delivery for bench tests were introduced via patches to the software. The computer programs were then updated at Honeywell and new program tapes incorporating these changes were shipped. New tapes were not prepared on a frequent basis (flight tests were performed using only the third revision of the original IPCS tape) and each revision involved literally hundreds of requirement changes. Honeywell had no in-house facility for verifying the changes. Such facilities must be available to support a production program.

Although the sequence of bench, SLS altitude and flight test progressed on schedule with technical success, the software requirement change process warrants improvement to reduce the risk of test schedule impact. Updates should be done more frequently. Patches should be limited to those changes required to maintain the test schedule. The first three major tests after software delivery - bench test, sea-level test, and altitude test - were, for most part, two-shift operations that were supported on-site by one software engineer. This one engineer supported both test shifts as well as designing, implementing, and documenting all required software changes. As a result, some mistakes were unavoidable and the attendant documentation was clearly inadequate. It is recommended that future test programs be supported by at least one software engineer to support test operations and one experienced individual at the test site who is responsible only for software design changes and maintenance of documentation. At appropriate intervals, new tapes, incorporating all changes made since the last formal revision would be issued by the control vendor. These new revisions would be subject to some level of verification testing using a flight hardware configuration and propulsion model simulation prior to shipment to the test site. In addition, the test set unit (TSU) should have the capability to close the control loop for software checkout in the field.

5.7 SOFTWARE DEVELOPMENT FOR ROM

The use of Read Only Memory (ROM) within the controller presents no problems in the software development process provided the two considerations addressed below are observed.

Although the IPCS experience did not include the use of ROM, the recommendation, herein is based upon Honeywell experience on other programs. This experience encompasses successful production programs, both commercial (digital air data system) and military (helmet sight) and numerous R&D and demonstration programs.

A necessary condition to achieve a successful ROM program is to use alterable memory during development and the initial phases of controller testing. Honeywell uses commercial, off-the-shelf, electrically alterable (RAM) memory. These are interfaced to the flight computer in a manner which is both electrically and physically (except for size and power requirements) identical to the ROM interface. This configuration is used during software debug and verification and subsequent system level tests whenever the environment permits. Honeywell has used commercial memory during flight test where safety-of-flight has not been a factor. The number of alterable configurations available, usually two or more, is a function of the number of simultaneous test and support activities in progress.

The recommended transition from RAM to read-only memory is during the last phase of ground based tests just prior to flight tests. This would permit maximum flexibility during all phases of pre-flight test while permitting sufficient lead time for ROM fabrication. The transition can, of course, be delayed if the alterable memory configuration is one which is flightworthy.

The second necessary condition to achieve a successful ROM program is to develop the software, beginning at the initial setting of requirements, to operate in the ROM configuration. In general, software developed without this goal in mind will not function in a ROM environment without extensive modification. If the controller software is developed in an assembly language, the separation of variables and constants according to the RAM/ROM configurations does not increase complexity or add to cost and schedule if (and only if) that separation is initiated at the onset. The same is true if a high-order language is used provided that language supports the use of ROM and the compiler can generate code compatible with the specific configuration. If not, some level of cost and/or schedule penalty is likely.

6.0 HARDWARE DEVELOPMENT

Hardware development covers the specification, design, procurement and/or fabrication, and flight assurance testing of components and subsystems that meet the requirements discussed in Section 3.0. The iterative nature of a development program will be especially evident in the hardware area. It is commonly found that the components needed to meet specific requirements are unavailable, impossible with existing technology, or are more expensive than anticipated. The requirements must be reassessed and the options weighed. Hopefully the requirements can be relaxed. Otherwise the extra cost, weight, space, or environmental protection burden must be assumed. If this is unfeasible it may be necessary to redesign the control algorithm to eliminate the offending component. A program to generate new component technology should be attempted only as a last resort.

It is of course imperative that hardware requirements not be changed unilaterally. In a closely integrated system, the impact of a single change can propagate through the entire system.

6.1 ENGINE RELATED COMPONENTS

For either an R&D type program or a production type new engine program, certain requirements should be established during the Preliminary Design Phase of the program to aid in the development trade studies to permit selection of the hardware. These requirements are as follows:

1. Accuracy, Response, and Resolution
2. Reliability, and Maintainability
3. Flexibility
4. Cost
5. Schedule (procurement and development time)
6. Weight and Volume

Each one of these requirements must be assigned a weighting function to permit the design engineer to evaluate those factors most important to his program. The criteria used to select hardware may be weighted to provide accuracy, response and resolution for the control mode, while maintaining maximum reliability. This would be done by using "existing" developed hardware with minimum engine plumbing and modification changes. This approach would probably suffer in flexibility, weight and volume, as these factors become secondary considerations.

When it is necessary to develop new hardware rather than to use existing components, this requirement should be identified during the study phase of the program to allow for development time of the individual component. It is equally important that if a newly developed component is to be used, that a reliable functional backup be provided.

In the IPCS program, reliability and accuracy were the dominant criteria, and a backup or synthesis was provided for all items considered to be at the newest level of design or proven performance. For example, the TIGT fluidic sensor system was new to the TF30-P-9 engine. As a backup the software was configured to synthesize the turbine inlet temperature signal. As it turned out, the TIGT sensor could not be installed in one of the engines due to a modification problem. The impact of this was minimized because the T4 signal synthesis was available as alternative source of the temperature signal.

The following subsections will discuss the criteria for hardware selection and how they could be applied to other programs.

6.1.1 Transducer Selection

Sensor selection is critical to any propulsion control system. The accuracy and response of each sensor may have a major impact on the accuracy and dynamic characteristics of the related control loops. Engine parameters vary over a wide range throughout the flight envelope; thus the control sensors selected must be capable of maintaining acceptable accuracy with a considerable turndown ratio (maximum value/minimum value). The engine nacelle is a hostile environment that exposes transducers to variations in temperature and to vibration that will reduce their useful life if they are not protected.

The approach to transducer selection starts with establishment of performance requirements. The next step is to review existing hardware to determine if proven components can be used. Two types of errors, steady state and dynamic (or transient), must be considered. Steady-state errors can be reduced by calibration if they are repeatable, as in the case of non-linearity, or if they can be related to environment, as in the case of thermal shift of a pressure transducer. Dynamic errors can be compensated if they are predictable and not excessive. Typical sensing devices exhibit a constant incremental error throughout their operating range, and the major impact on system accuracy occurs at the low end of the operating range when the error becomes a large percentage of the measured value.

The locations of the sensors are usually determined by a configuration trade study that considers factors such as performance, cost, weight, and reliability. The outcome of such a study may indicate that the sensors should be located on the engine to minimize pneumatic line lengths for best transient accuracy. This outcome satisfies the performance requirements. However the transducers may not be designed to tolerate the engine environment. If the configuration studies require the electronic control to be on the engine, the transducers may be packaged with the control, assuming that it is environmentally protected. If the control is mounted off the engine, separate environmental protection may be required for the transducers. An approach that may be selected to minimize transducer changes with environment and improve reliability is to package all sensors into a common cooled, insulated package.

The IPCS program considered both the strain-gage and vibrating cylinder pressure transducers for pressure measurement with the strain-gage type being selected for the engine. The strain-gage type was sufficiently accurate for the IPCS control loops and previous test experience had demonstrated their reliability.

The transducer box for the IPCS program had difficulty with braze welds that did not cover the required area, as detected by X-Ray measurements after vibration testing. The alternative was to eliminate fuel cooling, fill the box with silicone oil and rely on the insulation blanket for the required environmental protection. This approach was acceptable for the IPCS mission because of the limited time of exposure to high temperatures.

6.1.2 Gas Path Probes

The guidelines for gas path temperature and pressure probe selection are as follows:

1. Define signals that are required to control the engine.
2. Establish a priority of these measurements as to their impact on engine control.
3. Determine accuracy and number of probes required.
4. Assess the impact of these measurements on engine design or modification, structural impact to engine, and effect on engine schedule, cost, weight, maintainability, and reliability.

Probe design trade studies must be conducted to define such factors as probe configuration, location (axial, radial), and the number of probes required for obtaining consistent and repeatable measurements. Information to support these studies is obtained from analytical studies, rig testing and past engine experience.

The approach used in the IPCS program was to identify the probes required from the component requirements chart shown as Figure 3.1-1. Each measurement was evaluated to assess its impact on engine modification and probe development. All efforts were made to minimize the number of measurements required. This was accomplished by reworking the control mode algorithm to an acceptable configuration with a minimum number of measurements by using parameter substitution or signal synthesis. Only those signals determined to be critical for control were retained.

The basis for selection of gas path pressure probe design for the IPCS program was to meet the mode requirements while maintaining a high level of reliability. This was done by selecting proven reliable probe designs which had been used in previous programs. The same was true for temperature probes, where TF30 Bill-of-Material probes were retained.

6.1.3 Output Interfaces

The first step in selecting the output interface for a digital electronic control is to perform a trade study to identify the optimum approach for the application. The trade study must consider the following: steady state accuracy, transient response, reliability, maintainability, cost, weight, and size. Data from actual design and test experience, and requirements of the engine will provide the baseline for selection of candidate interface devices.

In the IPCS program, the output interfaces were selected by using the devices that most conveniently interfaced with existing hardware. A torque motor servo stage was selected to position the metering valve of the main fuel control upon command from the digital computer. Stepper motors were selected to control the zone metering valves and exhaust nozzle servo in the afterburner and exhaust nozzle control. In both systems resolvers were used to feed back the position of the valves.

The torque motor and stepper motors were selected for the different applications because each addressed the available hydraulic interfaces in the most reasonable manner. Both components had been used in similar flight applications and were, therefore, proven designs which increased the reliability of the system. The results of the IPCS tests indicated that the torque motor and stepper motors did in fact meet the accuracy and response requirements of the IPCS control modes.

6.2 INLET AND AIRFRAME RELATED COMPONENTS

Most of the hardware developed for propulsion control by the airframe manufacturer will be used in installing purchased components or equipment supplied by the controls or engine manufacturer. This includes mounts, environmental protection, and aircraft wiring. Some pressure probes may also be fabricated by the airframe manufacturer. The comments below are based upon IPCS experience in these areas.

6.2.1 Manufacturing Techniques and Procedures

The "red-line" drawing system lends itself readily to research and development programs, where only a small number of parts are to be produced. This allows the fabrication of the part to proceed without extensive drawing revision due to changes required during the manufacturing sequence. These changes are maintained in red-line form on a "master-drawing" and not incorporated in the original until the part is completed, has passed Flight Assurance Testing and is ready for QC approval. This approach saves much time during the development of new parts.

Materials technology groups should be consulted, early in the preliminary design phase, for feasibility studies if special techniques are being considered. Parts requiring special techniques such as critical welds should be avoided unless ample time is allowed to develop the technique.

6.2.2 Modification of Aircraft Structure

It is mandatory that structural drawings and cognizant personnel be available if changes are required to the aircraft structure. If drawings from outside the company are required, arrangements must be made to make them available on an easy and rapid basis. Approval of structural changes should be obtained from the design group that did the original design. Before initiating any changes much can be gained by discussing the proposed changes with the originating design group. Budget will have to be provided for this within the company. If the original design was done outside the company, a sub-contract for these services will probably be required.

6.2.3 Wiring

Wiring techniques will vary between research and production type programs. During "one time only" research programs, wire bundles can be fabricated and routed on installation. Clamping can be accomplished using existing structure to clamp to. Special shielding can be avoided through the use of Zip On Shielding. Special wire and connectors should be avoided because of problems of availability and cost.

6.3 CONTROLLER DEVELOPMENT

The development of the controller hardware should be performed concurrently with the development of the engine. An electronics system engineer should be available to perform trade studies in conjunction with the engine designers. System level studies to optimize the electronics environment would be performed during this period of development.

A chronological plan to be applied in the development of a controller for future propulsion control systems is presented here. Discussions provided in each development area discussing tradeoffs and/or providing recommendations are based on the experience gained during the IPCS program. The discussions are organized chronologically:

1. System studies and recommendations
2. Controller specifications, design, fabrication, and test

The initial system tradeoff studies and recommendations constitute the major portion of the following dissertation. Specification, hardware/software design, fabrication, and testing discussions relate to the relatively conventional procedures for development of a control system.

6.3.1 System Studies and Recommendations

6.3.1.1 On vs Off Engine Mounting of Electronics (Controller Company Viewpoint)

The IPCS Digital Propulsion Control Unit (DPCU) Controller was shock mounted in the weapons bay of the F-111. The aircraft environmental control system (ECS) provided cooling air. This off-engine special mounting was selected to enhance the reliability of this R&D controller. The off-engine environment provided a relatively easy, low-cost and low-risk design.

In the consideration of a production engine controller, however, there are some disadvantages to an off-engine mounting:

- a. Controller is not an integral part of the engine.
- b. Long heavy cabling may be necessary.
- c. Special airframe mount, with shock mounting and cooling, is needed.

If an engine mounting can be designed such that comparable shock mounting and cooling is provided on engine, the controller can be an integral part of the engine and long heavy cabling will be not required. The on vs off engine mounting then becomes a question of whether the engine can be designed to provide a controlled environment for the controller, and what the penalty of this is in comparison to cabling penalties, etc. of off-engine mounting.

Off engine mounting is completely practical as demonstrated by IPCS and can be implemented with conventional electronic assemblies. The hardware will, of course, be state-of-the-art, and consequently much smaller and require less power than IPCS, which makes off-engine mounting even more viable. There are three possible off-engine configurations:

1. Near to Engine (3 to 8 feet) such that pressure probe pneumatic lines can be run directly from controller to engine. This close-to-the-engine configuration, will hopefully provide an environment that is easily controlled to ensure the standard avionics electronic environment. A recent study indicates that the close-to-engine environment is not always greatly improved over the engine environment. This approach would have to be reviewed for each new airframe installation and would impose reoccurring costs for each installation. For these reasons a close-to-engine mount may have no significant advantage over the on-engine mount.

2. Farther away from the Engine (8 to 20 feet) such that the pressure and temperature transducers must be mounted on-engine in a transducer box. This configuration is equivalent to IPCS, and is therefore a proven method. The disadvantages, however, are the cable weight and special mounting required for each new airframe installation. If the weight of cable and special mounting requirements (to guarantee a conventional avionics electronics environment) can be obtained at a lower cost per airframe than on-engine, this approach is preferred.
3. A great distance from the Engine (over 20 feet). It now becomes applicable to consider a bus system with an on-engine mounted I/O converter with multiplexing and a MIL-STD-1553 or equivalent type bus. This approach is not attractive, as the on-engine mounted electronics to provide the I/O-mux requires the same consideration as the controller on-engine. The added complexity of designing two boxes for the controller is a decided disadvantage. This approach is attractive only when the I/O-mux is placed relatively close to the engine and a central total avionics processor system is used. This approach presents problems with engine acceptance testing, unless a separate backup controller is provided with each engine.

6.3.1.2 Power Requirements

The power source for the IPCS Program was the conventional MIL-STD-704 3 ϕ 400 Hz/28V dc power available on the F-111. However, the IPCS electronics design was complicated by the need to accommodate the power bus transients caused by bus transfers and load switching. This complication would be eliminated by a dedicated alternator, assuming that ground power is provided for initial start-up. The initial start-up power transient would be masked by a controller start-up timer.

A conventional alternator where the output voltage is related to rotor shaft speed is considered the best choice by Honeywell based on a study of four alternator design concepts. The output voltage from the 3-phase alternator will vary from 28V dc to 400V dc after full wave rectification. The alternator is designed to operate at 460° and can supply a maximum load of 300W. The maximum shaft speed is 36K RPM and ten percent shaft speed will supply a minimum of 28V dc output from the full wave rectifier. Alternators for this type application would be mounted inside the engine accessory gear box. The rotor material would be Alnico.

The 28V dc to 480V dc output of the full-wave-rectifier assembly will be converted to 28 + 6V dc by a switching regulator. This 28V dc supply would provide approximately 150W capability to drive solenoids, etc., and 150W to the electronic controller. A pulse width modulated inverter would supply the estimated 100 watts required by the electronic controller. The efficiency of this supply will be greater than 65 percent.

6.3.1.3 Back-up System, Fail Safe, Fail Operational, Redundancy

The discussion of reliability in section 3.5.6 covers the various design and quality features that can be used to enhance the reliability of the controller. In addition, the discussions of on vs off engine mounting imply that the electronics environment must be controlled to be equivalent to or better than the standard electronics avionics environment (-65°F to +160°F; 5G, 500 cycle vibration) in order to ensure reliability. Assuming that these design, quality, and environment requirements are fulfilled; a reliability MTBF greater than 30,000 hours is obtainable by use of crossed redundancy and a backup system.

The term crossfeed refers to switching subassemblies of redundant channels between the channels to bypass a faulty subassembly. When a channel-one sensor fails, for example, the channel-two redundant sensor is switched to supply inputs to both channels. Failed subassemblies are identified through an automatic built-in-test (BIT), and the switching is performed by solid-state devices. This crossfeed-redundancy can provide a fail-operational/fail safe system. Crossfeed redundancy has been used by Honeywell in a number of flight control systems and the Space Shuttle Main engine controller.

The addition of other IPCS features such as automatic reversion to a simple hydro-mechanical backup. Manual selection of the same backup would provide an additional fail-operational (reduced capability) system. In addition, a manual engine shut-down capability will provide for fail safe operation of multi-engine aircraft.

6.3.1.4 Mechanical Design

The engine design should if feasible, provide for shock mounting and insulation of the electronics controller. An air-cycle heat exchanger could then be used to cool the controller. The controller should be designed such that its internal power dissipation will be less than 100W as a design goal.

If these conditions can be satisfied, the electronics packaging can consist of standard packaging concepts with electronic circuitry designed such that internal power dissipation with a maximum ambient of 160°F will never exceed a 125°C junction temperature.

6.3.1.5 Testability, Maintainability, Dispatchability

The DPCU utilized in IPCS provided good testability, maintainability, and dispatchability for a research system. A production system will require a design which provides automatic integral preflight, a semi-automatic flight line tester, and a Least Replaceable Unit (LRU) repair station. The mechanical design must consider ease of replacement of LRU's to improve maintainability. In addition, the inclusion of dual redundant crossfed channels or other backup would improve dispatchability.

6.3.1.6 Interface to Other Systems

The principal IPCS Interfaces were those between the controller and the engine (sensors and actuators); the manual inlet control; the NASA recording system; and the aircraft installation. These interfaces have great potential for problems, therefore, coordination and design review meetings at the working engineer level must be held at regular intervals to review these interfaces. Such meetings held during the IPCS program were more effective than the use of interface specifications alone would have been.

Another technique used was the loan of actual sensors and actuators to the control designer during the circuit breadboarding stages. This facilitated checkout of the interface long before the integration of the system, and many potential problems were avoided.

The design of the I/O for the IPCS controller considered failure modes of interfacing equipment. Current limiting and voltage clamping were used to protect the DPCU. It is recommended that like precautions be taken on future engine controller designs.

Perhaps the best indicator of synergy in the IPCS program was the ability of Boeing, P&WA, Honeywell, NASA/Lewis, and NASA/DFRC personnel to work together in the solution of interface problems. An early definition of the I/O was established within a month of go-ahead. Constant review and update of these I/O tables and specifications by all parties established good working relationships. Movement of the controller to the field test arenas of Hartford, Connecticut; Cleveland, Ohio; and Edwards, California, was marked by a high degree of cooperation and "esprit de corps".

The following recommendations are provided based on IPCS experience:

1. Provide early preliminary I/O tables and specifications which are reviewed and updated throughout the early stages of the program.
2. Hold working coordination meetings to brainstorm, and to define interfaces.
3. Provide actual interface hardware to the control designer during the breadboard stages of development.
4. Specify clamping and current limiting requirements at the interfaces. Specify other design requirements to protect the controller in the event of an external failure.
5. Establish and demand "esprit de corps" between participants in the program. Insist: You must work together!

6.3.1.7 Computer Configuration

The chronological development of control systems has in the past usually started out with the selection of the computer. The system has then been configured around that computer. The IPCS computer was selected that way, and the flexibility of this computer insured that a system for a research program could be configured.

Design trade studies using state-of-the-art microprocessors in various configurations must be performed. The specifications must not prevent the computer systems designer from configuring the optimum computer for the system. It is recommended that a trade study between a single processor and a multi-processor be performed.

The multi-processor system, if selected, could use a micro-processor for control of the I/O. This micro-processor would provide control of the analog-digital converters, etc.: it would convert raw data to corrected data, and would perform other data handling calculations. The results of its work would be periodically placed in I/O scratch-pad memory which would be accessed by the algorithm solution processor(s). This I/O processor approach is further described in section 6.3.1.10, I/O Design. A second processor (and possibly a third) would be used for performing the basic algorithm solutions. The anticipated advantages of a multi-processor system are adequate capacity with the use of slower and less expensive processors, better power distribution fewer potential EMI problems, and easier programming.

A single-processor system if selected, could be very similar to the HDC-601 used on IPCS, although with the deletion of some features. It would probably be one of the new militarized state-of-the-art micro-processors.

6.3.1.8 Memory Configuration

The lowering cost of solid-state memory devices indicate that they will ultimately replace core and plated wire memories. These memories not only promise lower cost, but also provide smaller size and ease of interfacing. In the early development of the controller, volatile Random Access Memory (RAM) can be used in conjunction with a cassette for permanent storage of the program. At each power up the RAM would be externally loaded from the cassette. When the controller program has been perfected, the fixed program locations can be placed in Read-Only Memory (ROM), while the variable locations will continue as RAM. Device constants such as those associated with specific pressure transducers or engine trimming can be saved in Programmable Read-Only Memory (PROMS). A small ROM can be installed as an integral part of each pressure transducer, so that changing a transducer will automatically change the constants associated with the unit.

The configuration and control of the controller memory depends upon the computer configuration selected as a result of the computer tradeoff study. Another effect on memory configuration and control is its dependency on the redundancy configuration selected for the controller.

The recommendations for memory configuration are:

1. Use solid-state memories
2. Use all RAM's loaded by cassettes during initial development
3. Use integral ROMS for devices with specific constants
4. Convert the final fixed program into ROMS
5. Provide some RAM for scratch-pad memory requirements
6. Final memory configuration is dependent upon computer and reliability-redundancy tradeoff studies

6.3.1.9 Transducer and Actuator Interface Requirements

A number of the sensors and actuators used on IPCS required an inordinate amount of electronics in the I/O interface. Figures 6.3-1, -2, -3, provide trade comparisons of various IPCS electronic I/O conversions. These may be used in studies for the design of an I/O that consists of A/D converters, D/A converters, S&H circuitry, analog MUX circuitry, demod circuitry, and torque motor drivers. The recommended I/O is described in Section 6.3.1.10 "I/O Design". These recommendations reflect the electronic circuit design optimization only.

Figure 6.3-1 compares the amount of hardware, accuracies, conversion times, and other features of strain-gage vs. quartz crystal pressure transducers. These comparisons are primarily concerned with the electronics required for conversion of the two signal types. IPCS has demonstrated that stable A/D converters with accuracy less than +0.1% are obtainable. It has also been shown that frequency-signal pressure transducers can be converted with an accuracy better than 0.06%. Correction and calibration constants were applied by the computer for both conversion methods. The new state-of-the-art solid-state strain-gage bridge pressure transducers promise accuracy comparable to the quartz crystal transducers.

IPCS experience indicates that a pressure transducer which provides a DC voltage signal is preferred over a frequency signal transducer if either is capable of providing the desired accuracy. Less time and hardware required for the conversion make the DC signal desirable. The IPCS MUX-A/D conversion required 205 microseconds, while Frequency-to-Digital (F/D) conversion required 10 to 15 milliseconds.

IPCS demonstrated that position measurements can be made either by resolvers or by LVDTs. Another possibility is a Rotational Variable Differential Transformer (RVDT), which has conversion and excitation requirements similar to the LVDT. Figure 6.3-2 provides a comparison of these position sensors. If an A/D converter is present, the LVDT or RVDT position sensor is desirable as the amount of hardware required is less than that required for a Resolver-to-Digital (R/D) converter. The time to convert with a R/D converter is 1 MS (for a 1 KHz excitation) while the IPCS A/D converter performed the conversion in 205 microseconds. Less hardware and time to convert are features that make the LVDT and RVDT the attractive position sensors.

The resolver conversion can also be performed by demodulation, A/D conversion, and then a ratio calculation by the computer. This method requires precision excitation or a measurement of the excitation for correction by the computer.

The impact of output actuators on the electronics design is shown in Figure 6.3-3. This chart shows that the IPCS stepping motor outputs required more hardware and more power than the torque motor outputs. The D/A - S&H outputs were also used for other uses such as data acquisition or indicator drivers. The D/A usage can be easily expanded by the addition of output mux, S&H, and current source torque motor driver circuitry.

The lower hardware and power requirements and the greater flexibility of torque motor interface electronics over stepping motor interface electronics indicates that torque motors are attractive for position outputs.

STRAIN-GAGE PRESSURE TRANSDUCERS (DC INPUT)

CONVERSION ACCURACY $\pm 0.1\%$
 205 MSEC TO CONVERT
 DIFFERENTIAL INPUT (ANALOG)
 3 CARDS FOR 1-15 INPUTS
 8 CARDS FOR 17-31 INPUTS
 4 WIRES + SHIELD/INPUT
 CAPABILITY FOR OTHER
 INPUTS

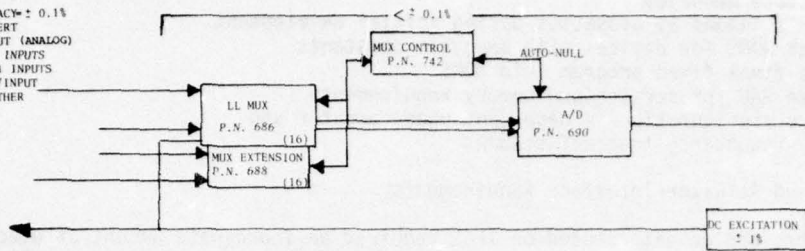

COMMENTS ON SOFTWARE INPUT PROCESSING

EXCITATION SPAN AND OFFSET CORRECTION APPLIED AUTOMATICALLY TO ENHANCE ACCURACY.

PAROS-PRESSURE TRANSDUCERS (FREQUENCY INPUT)

CONVERSION ACCURACY $\pm 0.06\%$
 10 - 15 MSEC TO CONVERT
 SINGLE-ENDED INPUT (DIGITAL)
 3 CARDS FOR 6 INPUTS
 4 CARDS FOR 8 INPUTS
 8 CARDS FOR 16 INPUTS
 3 WIRES + SHIELD/INPUT
 GROUND RETURN THROUGH SYSTEM FRAME
 GROUND (POTENTIAL NOISE PROBLEM)
 PRECISION STABLE CLOCK REQUIRED

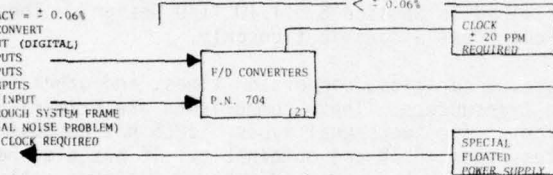

DIGITAL DATA AND CONTROL

EACH DEVICE REQUIRES CALIBRATION PARAMETER STORAGE

HONEYWELL SOLID-STATE PRESSURE TRANSDUCERS ARE STATE OF THE ART: PROVIDE CAPABILITY FOR AUTOMATIC TEMPERATURE CORRECTION AND USE RATIO-METRIC DESIGN CONCEPT
 RANGES POSSIBLE: 1 TO 10,000 PSI
 ACCURACY: $\pm 0.03\%$ OF FULL SCALE
 STATIC, TOTAL, OR DIFFERENTIAL
 PRESENTLY USED ON THE DC10 DIGITAL AIR DATA SYSTEM
 COMMERCIAL VERSIONS USED ON VARIOUS AUTOMOTIVE APPLICATIONS

Figure 6.3-1 Electronic Signal Processing of Pressure Transducers

RESOLVERS - ROTATION

$\pm 40^\circ$ RANGE
 $\pm 0.5^\circ$ END-TO-END ACCURACY*
 4 CARDS FOR EIGHT INPUTS
 40 WIRES FOR EIGHT INPUTS
 1 MSEC CONVERSION TIME
 (AT 1 kHz EXCITATION)

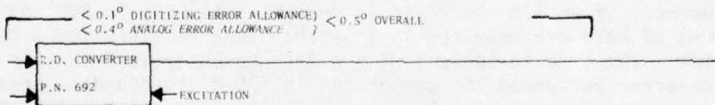

COMMENTS ON SOFTWARE INPUT PROCESSING

LINEAR, FAILURE TEST ONLY

LVDT'S - LINEAR

± 0.1 INCH TO ± 10 INCH RANGE
 $< 1.1\%$ LINEARITY AND TEMPERATURE
 $< 22.5\%$ OF POSITION*
 2 CARDS FOR EIGHT INPUTS (INCLUDES EXCITATION CONVERSION)
 USE EXISTING A/D AND MUX
 52 WIRES FOR EIGHT INPUTS
 0.205 MSEC CONVERSION TIME

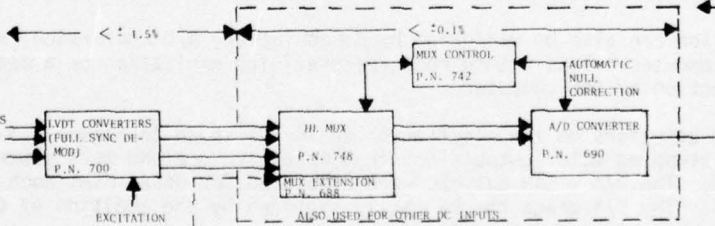

DIGITAL DATA AND CONTROL

LVDT AND RVDT USE RATIO (INPUT TO EXCITATIONS) CONVERSION TO ENHANCE ACCURACY

RVDT'S - ROTATION

$\pm 40^\circ$ RANGE
 $< 0.5^\circ$ END-TO-END ACCURACY*
 2 CARDS FOR EIGHT INPUTS (INCLUDES EXCITATION CONVERSION)
 USE EXISTING A/D AND MUX
 52 WIRES FOR EIGHT INPUTS
 0.205 MSEC CONVERSION TIME

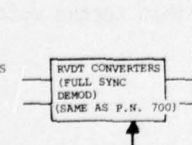

*CALIBRATION OF INSTALLED POSITION REQUIRED

Figure 6.3-2 Electronic Signal Processing for Position Transducers

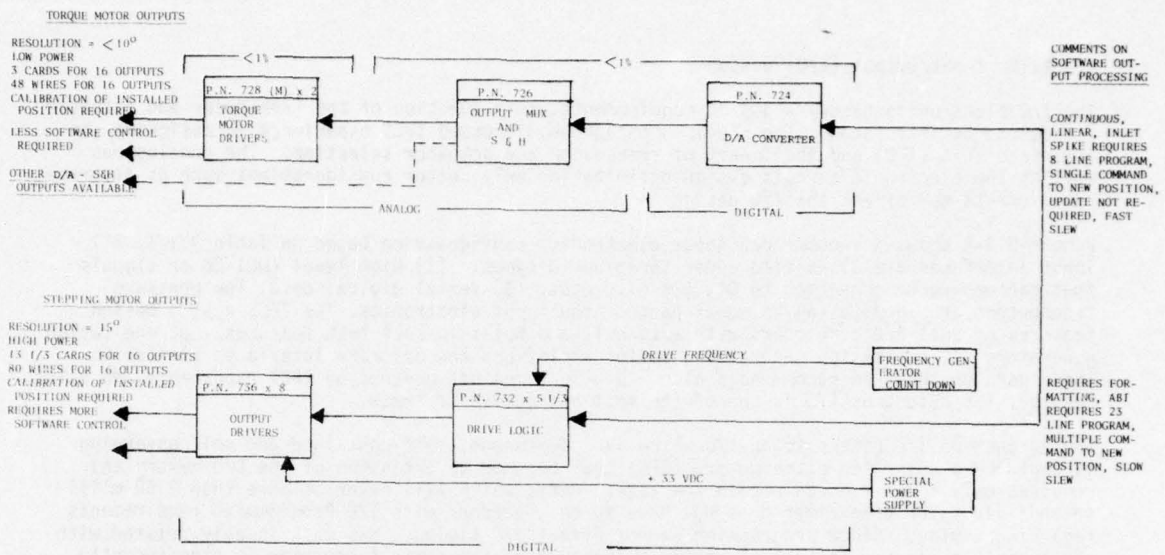

Figure 6.3-3 Electronic Conversion for Position Outputs

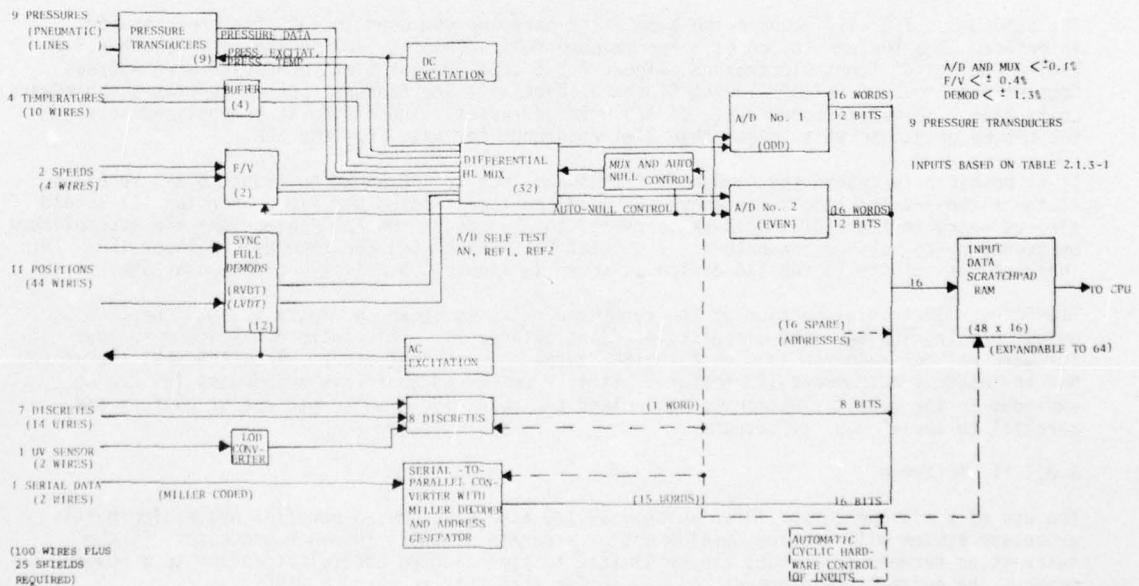

Figure 6.3-4 Recommended Input Electronics Configuration

6.3.1.10 Input/Output (I/O) Design

The I/O electronics hardware design requirements are a function of the transducer and actuator devices to be interfaced. The previous paragraph discussed IPCS experience in designing the interface unit (IFU) and the impact of transducer and actuator selection. The conclusions reflect the electronic circuit design optimization only; other considerations such as accuracy requirements may affect the I/O design.

Figure 6.3-4 shows a recommended input electronics configuration based on Table 3.1-1. All input interfaces are classified under three basic types: (1) high level (HL) DC or signals that can easily be converted to DC, (2) discretes, (3) serial digital data. The pressure transducers are shown as an integral part of the input electronics. The IPCS system design features of dual A/D converters with auto-null and built-in self test features. DC excitation generators, AC excitation generators, buffer amplifiers and discrete interfaces similar to those used on IPCS are recommended also. New features not covered by IPCS experience, do exist, however. An autonomous I/O is one of the most attractive of these.

The Autonomous I/O refers to an I/O which is independent, self-contained and self governing. It would have a scratch patch memory (SPM) that becomes an extension of the CPU memory and requires only to be read to obtain the latest data, which will never be more than 2.56 milli-seconds old. The programmer does not have to be concerned with I/O Programming requirements regarding timing. Since programming cannot effect I/O timing. His task is only related with the propulsion system control algorithm. The load on the central computer is significantly reduced, because instructions are not required for the I/O control. A micro-processor can perform data conversion and validity testing. It can also perform built-in-test and limited backup control.

An autonomous I/O makes it easy to implement an I/O interface to a serial bus (such as the MIL-STD-1553 bus) because only a remote scratch pad memory (SPD) must be interfaced. The SPM acts as an external interrupt buffer. The serial bus also provides inherent capability for cross-feeding at the I/O to CPU interface for redundant system reliability optimization.

The autonomous I/O will require the same basic hardware now used in IPCS for the computer interface. The implementation of a recommended full autonomous I/O is shown by Figure 6.3-5 Timing Control of Input Electronics, Figure 6.3-6 Input/Output Electronics 128 Word Address Counter and Figure 6.3-7 SPM-Timing Sequence (Partial). The Address Counter generates a hardware controlled 2.56 milli-second cycle of 128 word addresses. The timing is established so that the CPU never has to wait longer than 2 microseconds for data from the SPM.

It is possible to expand the number of A/D inputs from the 32 shown on Figure 6.3-5 to 64 as state-of-the-art techniques can reduce by half the time allotted per A/D conversion. It should also be noted that the DISIN can be increased to 8 words if the F/D conversions are accomplished by frequency-to-voltage converters. The total DISIN discretes can then be 8 x 16 or 128. This inherent flexibility in the I/O design as shown in Figure 6.3-5 is a decided advantage.

The Output Electronics portion of the recommended I/O is shown in Figure 6.3-8. The IPCS output electronics DA - S&H circuitry used was autonomous. This feature was added so that software was not required to update the S&H outputs to prevent droop. The IPCS IFU, therefore, had an integral autonomous I/O feature. It is recommended that this autonomous feature be expanded in the output electronics to include the servicing of discrete output buffers and parallel to serial digital outputs.

6.3.1.11 Software

The use of a microprocessor in an autonomous I/O as a distributed parallel processing multi-processor system will require development of separate software for each processor. If the interaction between processors can be limited to time enabled control of access to a common memory, the software development can be simpler than that required by IPCS.

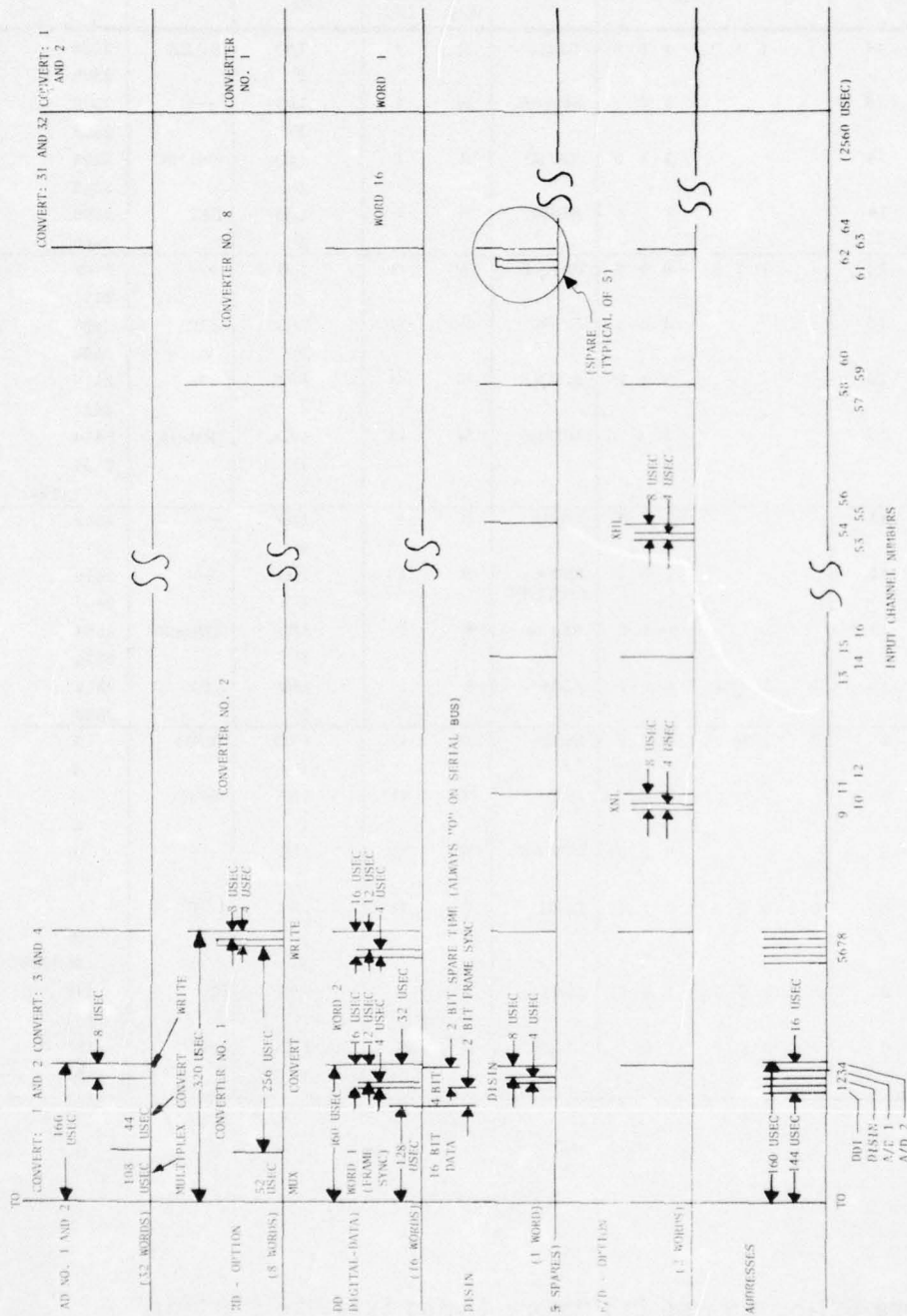

Figure 6.3-5 Timing Control of Input Electronics

Channel Number	I/O	Address Counter	Address Control	Convert	T ₀ ^(IE) _{OE}		Access Processor/ I/O	Function	Time (μsec)	
					W/R	I/O				
116	I	14	1 1 1 0	1 0 0	DDI15	R	I	I/O	BUZZ	2386
								P		2388
117	I	14		1 0 1	SPARE	R	I	I/O	---	2390
								P		2392
118	I	14		1 1 0	ADI50	R	I	I/O	EXMDC	2394
								P		2396
119	I	14		1 1 1	ADI5E	R	I	I/O	LEI	2398
								P		2400
120	O	15	1 1 1 1	0 0 0	SPARE	W	O	I/O	---	2402
								P		2404
121	O	15		0 0 1	DA16	W	O	I/O	HM4	2406
								P		2408
122	O	15		0 1 0	SPARE	W	O	I/O	---	2410
								P		2412
123	O	15		0 1 1	DD016	W	O	I/O	DDW15	2414
								P		2416
								P		2544 (128)
124	I	15		1 0 0	DDI16	R	I	I/O	---	2546
								P		2548
125	I	15		1 0 1	RE8- OPTION	R	I	I/O	---	2550
								P		2552
126	I	15		1 1 0	AD160	R	I	I/O	ADREF	2554
								P		2556
127	I	15	1 1 1 1	1 1 1	AD16E	R	I	I/O	LE2	2558
								P		2560
0	O	0	0 0 0 0	0 0 0	DIS01	W	O	I/O	DIS01	2
								P		4
1	O	0		0 0 1	DA1	W	O	I/O	WFE	6
								P		8
2	O	0		0 1 0	SPARE	W	O	I/O	---	10
								P		12
3	O	0	0 0 0 0	0 1 1	DD01	W	O	I/O	DDFS	14
								P		16
								P		144 (128)
7	I	0	0 0 0 0	1 0 0	DDI1	R	I	I/O	XM	146
								P		148
5	I	0	0 0 0 0	1 0 1	DISIN	R	I	I/O	DISIN	150
								P		152

Figure 6.3-6 Scratch Pad Memory Timing Sequence (Partial)

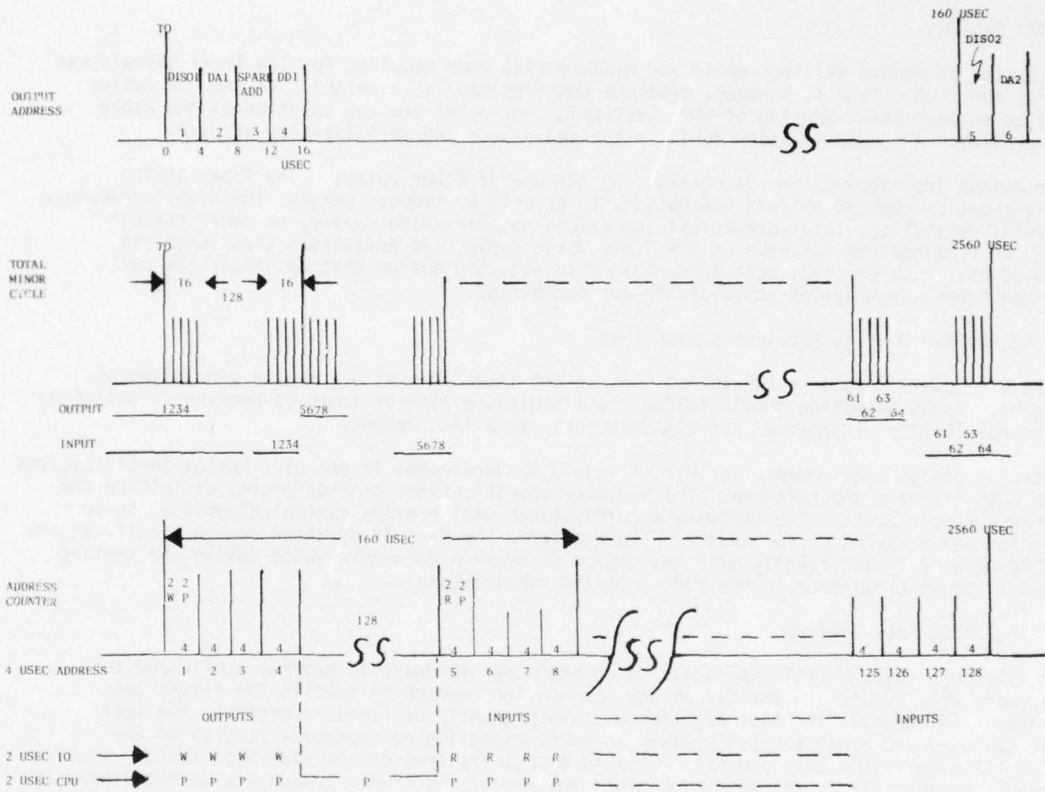

Figure 6.3-7 Input/Output Electronics 128 Word Address Counter

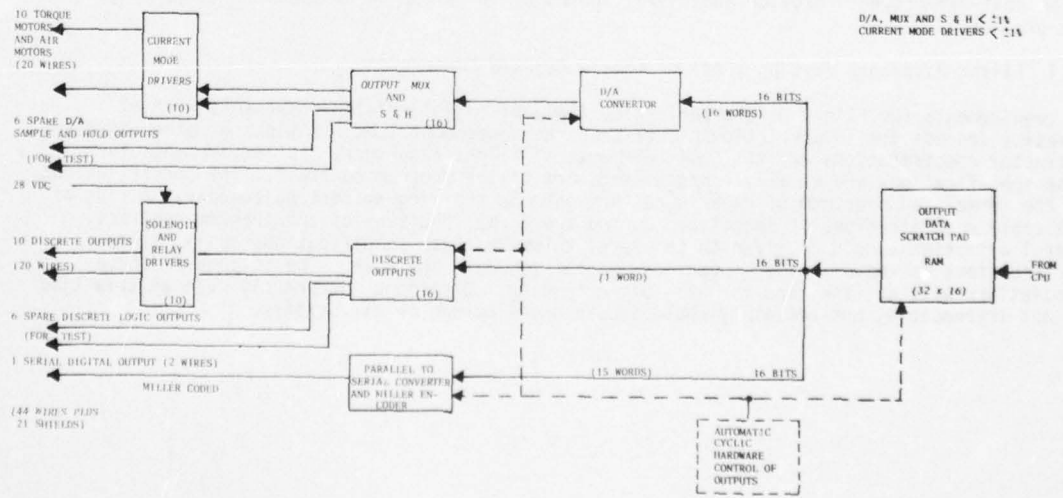

Figure 6.3-8 Recommended Output Electronics Configuration

AD-A033 062

BOEING AEROSPACE CO SEATTLE WASH
INTEGRATED PROPULSION CONTROL SYSTEM. VOLUME IV. METHODOLOGY. (U)
AUG 76 L O BILLIG

F/G 21/5

F33615-73-C-2035

UNCLASSIFIED

AFAPL-TR-76-61-VOL-4

NL

2 of 2
AD
A033062

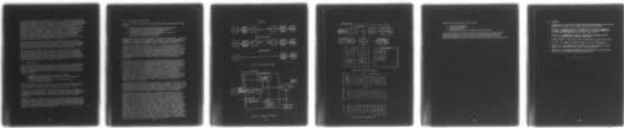

END

DATE
FILMED
1 - 77

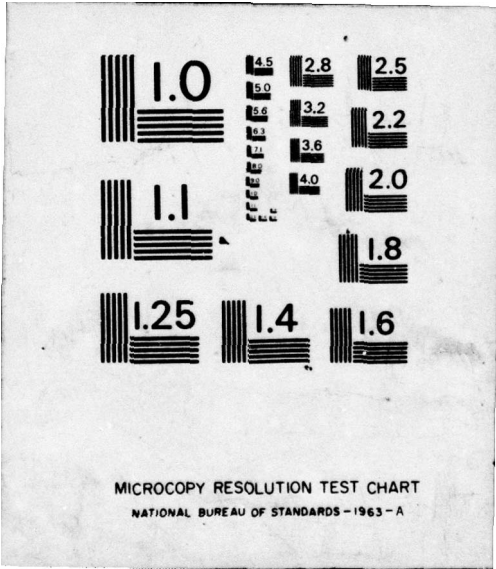

MICROCOPY RESOLUTION TEST CHART
NATIONAL BUREAU OF STANDARDS - 1963 - A

6.3.1.12 Cabling

The selection of double shielded cable and differential mode coupling for low level signals was effective for IPCS. It did, however, generate considerable cable weight. The shorter cables related to an on-engine mounting of the electronic controller are one solution to the cable weight problem. A second solution could be the conversion and serialization of data.

Further system improvements may be obtained by the use of fiber optics. The fiber optics coupling promises reduced emi/rfi susceptibility as well as reduced weight. The high temperature (450-700°C) capability, total electrical isolation, no spark/fire hazard, no short circuit loading, no ringing/echo features of the fiber optic cable, are advantages that force its consideration. A trade study must be performed to select a system that optimizes the cable design and takes advantage of state-of-the-art technology.

6.3.2 Controller Design, Fabrication and Test

A system breadboard should be fabricated, tested and interfaced with a hybrid simulation of the engine. Parts selection should follow the expeditious plan of order-of-preference selection with the possibility of approved non-standard parts as a last resort.

The detailed design requirements definition should be documented in two-part Design Specifications (DS) for both hardware and software. The hardware specifications provide system definition and performance requirements. The software specifications will provide control algorithms to be implemented and methodology for their implementation. The Part II of these design specifications should be developed concurrently with the design to provide documents which define the testing required to prove compliance to the Part I design requirements.

6.4 FLIGHT ASSURANCE TESTING

Flight assurance testing (FAT) is conducted on prototype hardware to provide confidence that the hardware will survive in the flight environment long enough to fulfill the flight test objectives. In general, the test articles must subsequently be flown; therefore, the tests must be designed and conducted judiciously to avoid expending an excessive portion of the articles lifetime in the test process. This is especially true of the vibration tests. It may for example be possible to use mass simulators instead of electronic components during vibration tests to develop shock mounts, etc. It may be determined that the standard military specifications, e.g., MIL-E-5400, call out testing to environmental conditions that are far more severe than the component will encounter in operation. In this case it may be advisable to seek a deviation from the specified test. If, however, the full Mil-Spec test must be conducted and it is suspected that an undue portion of the life of a key component is consumed in the process, it may be cost-effective to provide additional spares of the affected component for the flight-test program.

6.4.1 Flight Assurance Testing (FAT) of Engine Related Components

The requirements for Flight Assurance Testing (FAT) of engine related components must of necessity address the interrelationship between the government specifications or other involved contractor specifications and the basic elements of flight assurance. The requirements for these specifications are usually a negotiated part of the program contract. The specifications are the formalized spectrum of experience that governs the program test philosophy. A list of applicable specifications is negotiated during the formal drafting of the program contract. Careful attention should be given to the level to which these specifications apply, since specifications can have a major impact on program schedule and cost. The outcome of these negotiations will set the tone for all future testing. Decisions incorrectly made at this time are not irrevocable, but certainly could impose undue burden on all parties.

The system's suitability for flight must be established prior to performing the actual flight test portion of the program. Three methods to establish the necessary level of assurance are:

1. Flight Assurance by similarity-
The selection of hardware that has a documented history of successful use on prior flight test programs.
2. Flight assurance by analysis-
The use of design analysis techniques to provide the necessary indications that program hardware have adequate safety margins.
3. Flight assurance by test-
The use of tests carefully planned to probe the areas of the design which have the least documented history, or the use of system tests run to establish the viability of the overall program.

Note that the use of one avenue does not necessarily exclude the use of another. These are complementary functions and judgment must be used in their application, because of their potentially large impact on program cost and program schedule. This judgment must be tempered by the applicability of the previously established contract specifications. Obviously, the minimum risk program position, and consequently minimum cost and minimum schedule position, is assumed if all the program hardware is similar to hardware which has a documented history of successful prior use. Hence, a program goal must be to maximize the use of hardware with successful prior use. Since by its very nature the development program is concerned with proving an untried principle, through test, some untried hardware would be expected. A two-fold approach is required to assure that this hardware is suitable for flight.

First, it must be adequately shown by analysis that adequate safety margins exist in critical areas of the design. The "Critical Areas" are of necessity a judgment on the part of the design system, which encompasses the designer, the stress analyst, the metallurgist, and the project engineer. At this point in time a design is still on paper; therefore, changes can be easily effected with minimum program impact.

Second, the required individual hardware test sequences must be established during this preliminary design phase. Individual hardware test sequences are established by a combination of the judgment of the personnel associated with the design of the part, their knowledge of the system that will contain the part, and the specification associated with the program contract.

6.4.2 Flight Assurance Testing of Electronic Equipment

Flight Assurance Testing from the electronic manufacturers standpoint will vary depending his degree of responsibility in the program and the stage of the program. In an ideal program such as IPCS, where the control manufacturer is an integral part of the team and has participated from the outset, he may not have specified the control mode, but he will have been plainly involved in its implementation and modification. As such, he will have a real time simulation of the propulsion plant and the initial development FAT will be of two types:

1. System hardware integration tests where the fundamental operation of the hardware and its software will be tested with a real time simulation of the plant to ensure compatibility.
2. Hardware tests conducted with abbreviated program of environmental testing simulating flight conditions to demonstrate that the hardware is suitable for initial development type flight tests.

It is important for the planner to recognize the need for the controls manufacturer to:

- 1) have the appropriate test requirements from the engine and airframe manufacturers.
- 2) have a tailored real time simulation of the engine;
- 3) to incorporate time in the program schedule for the various FAT;
- 4) have the test procedure documentation preparation and approval cycles planned;
- 5) have appropriate peripheral equipment to test the hardware;
- 6) have planned the hardware and software development programs to ensure synchronization and finally, since the program inevitably entails change to the initial hardware, extra hardware and peripherals should be provided so that the controls vendor can verify the changes that are made.

FAT of the hardware include the following type testing: 1) functional of both a short (abbreviated) form and long (complete) form to establish pre and post test condition of the equipment; 2) high and low temperature conditions; 3) altitude conditions; 4) vibration; 5) shock, etc. Initial tests are generally non destructive, intended only to ensure that the equipment is flightworthy, as opposed to qualification tests which establish life/durability and associated performance.

Engine mounted equipment which is subject to environmental extreme in its life should also be required to demonstrate fatigue resistance from long term thermal cycling between thermal extremes. It is important to recognize this requirement in the planning stage because it has a profound effect upon the design itself as well as the test program.

6.4.3 Flight Assurance Testing of Airframe - Mounted Equipment

The IPCS program did not generate any unusual requirements in the FAT of airframe mounted equipment. The vibration tests had by far the most significance for items such as the shock probe, the LVDTs used for sensing inlet surface positions, and the DPCU box.

The shock probe and LVDTs were vibrated to $\pm 15g$ over the frequency range from 90 to 2000 hz per NASA DFRC Process Specification No. 21-2. The test articles were marked "For Ground Use Only" subsequent to the tests and so were not flown.

The DPCU box, which contained the DCU, the IFU, and the PSU, was vibrated only to $\pm 5g$ since it was to be mounted in the weapons bay and so was subjected to lower vibration levels than equipment mounted in the inlet area. The vibration input is shown by Figure 6.4-1. Wooden blocks ballasted to simulate the weight and c.g. location of the electronic components were installed during these tests instead of those components.

No shock isolation was used in the original configuration and vibration loads as high as $\pm 21g$ were measured at some box locations with a $\pm 5g$ input at the mounting pads. This was clearly unacceptable since the electronic modules were also designed to tolerate $\pm 5g$.

The tests on the DPCU box were re-run with standard-sized pads of synthetic rubber used for shock isolation. The properties of the material, BMS 1-50 Duro 60 rubber and BMS 1-11 Duro 60 rubber were known. It was possible, with some experimentation with pad thickness and configuration, to reduce with frequency and amplitude of box resonance to acceptable levels. The spring constants and damping coefficients of the rubber mounts as calculated from the known configuration and the properties of the rubber were used to select shock mounts of standard design.

Tests run using the production shock mounts, Barry Model T64-AB-35 on the forward end of the box assembly and Model T64-AB-80 on the aft end, verified the mount selection. Subsequent tests run with the electronic components installed instead of the mass simulators were conducted without incident.

The following aspects of the experience related above are considered relevant to IPCS methodology:

1. It is extremely difficult to design structures that will not amplify input vibrational loads at some frequency. If a module must tolerate a specified vibration level at the mounts, then almost certainly some form of isolation must be provided or some of the components must be able to tolerate much higher levels.
2. The use of mass simulators spared the electronic component from the abuse they would otherwise have suffered during the preliminary and developmental tests of the mounting system.
3. The spring constants and damping coefficients required for satisfactory vibration isolation can be determined experimentally by using material of known dimensions and properties. It is not suggested that this approach replace analysis, but it can supplement and verify analysis and is certainly a viable approach when a solution must be found quickly.

REF: NASA/DFRC PROCESS SPEC. 21-2

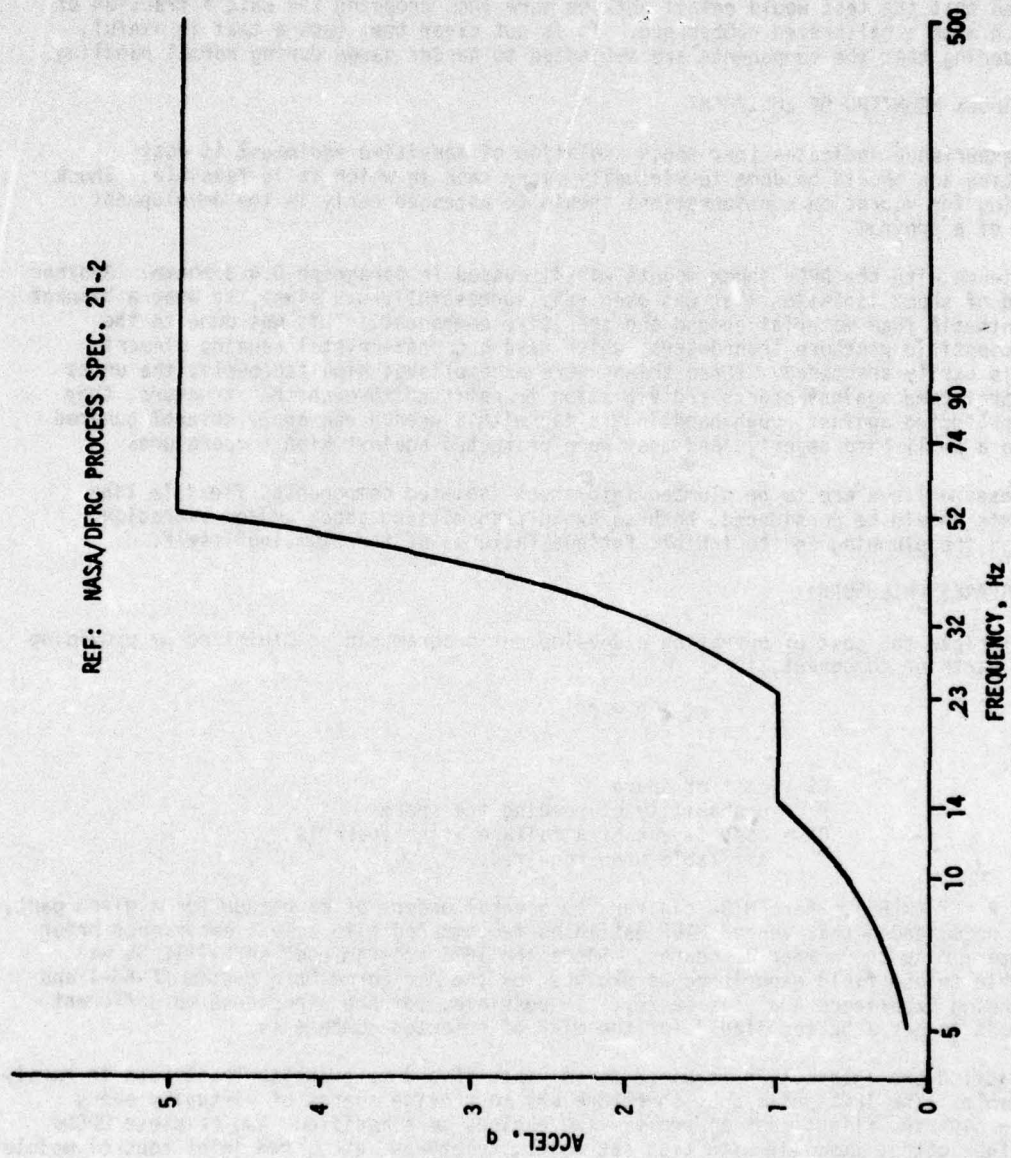

Figure 6.4-1 Vibration Input to DPCU Box

4. Mass simulators cannot represent precisely the compliance and damping characteristics of other hardware components; therefore, it is important to conduct final verification testing with the flight configuration.

The shock tests that had been specified for the DPCU (15g half-sine pulse of 11 msec duration) were deleted from the test plan with government approval when it was learned that the test would entail nothing more than dropping the unit a fraction of an inch onto a calibrated rubber pad. It is not clear that such a test is useful, considering that the components are subjected to harder usage during normal handling.

6.5 SHOCK MOUNTING OF EQUIPMENT

IPCS experience indicates that shock isolation of sensitive equipment is cost effective and should be done in virtually every case in which it is feasible. Shock mounting for vibration considerations should be assessed early in the development phase of a program.

Experience with the DPCU shock mounts was discussed in paragraph 6.4.3 above. Another method of shock isolation that was used very successfully was simply to wrap a blanket of synthetic foam material around the sensitive component. This was done to the Paroscientific pressure transducers, which have a quartz-crystal sensing element that is easily shattered. Three things were accomplished simultaneously; the units were protected against shocks and vibration transmitted through the structure, they were protected against rough handling (a tap with a wrench can apply several hundred g's to a small hard object), and they were protected against high temperatures.

If pressure lines are to be plumbed into shock-isolated components, flexible line segments should be considered, both to avoid transmitting shock and/or vibration through the plumbing and to inhibit fatigue failures of the plumbing itself.

6.6 SPARES PHILOSOPHY

In principle the cost of operating a development program can be minimized by providing spare parts or components if

$$CS < P * CF$$

where:

CS = cost of spare
P = probability of needing the spare
CF = cost impact of a failure if no spare is available when required.

Since $P = f(\text{MTBF})$, where MTBF can vary by several orders of magnitude for a given part, it is recommended that vendor MTBF estimates be compared with actual experience prior to determining the number of spares. Since the IPCS program used an F-111E it was possible to use field experience as provided by the Air Force Data System AF-66-1 and the Boeing Experience Analysis Center. If possible, compare experience on different aircraft to get a better "feel" for the MTBF of selected components.

In practice the information required to estimate CF and to exercise the trades is rarely available. The IPCS philosophy therefore was to provide spares of virtually every item except the flight test aircraft: Two engines were modified, two complete DPCUs were fabricated, complete with test set units, teletypes, etc., two inlet control modules and two sets of inlet position transducers were provided. In the case of pressure transducers, two engine sets plus one spare of each part number of the well developed MB Alinco units were procured. The Paroscientific transducers were not considered mature, proven designs at the time, so 1-1/2 ship sets, or 12 units were purchased.

The fluidic T4 transducers were considered to be short-lived expendible items, so enough units were provided to last through the projected engine operating time. These were not therefore considered spares in the accepted sense of the term.

The IPCS spares philosophy proved to be completely satisfactory. Absolutely no test time was lost due to unavailability of spare components or parts provided as IPCS hardware. On the other hand, if all unused parts were returned to the manufacturers for a full cash rebate, the sum recovered would be only about 0.3% of the cost of the program.

The availability of two complete sets of hardware also greatly facilitated the conduct of the test program. With four major system-level tests, there were three instances where a set of hardware was moved to a test site, set up and check-out initiated before the previous test in the series had been completed.

In summary, based on IPCS experience, there does not appear to be any justification for procuring and maintaining less than one complete set of spares for a major development program. The decision on whether to procure more must be based upon the following considerations:

1. Cost of additional spares
2. Probability of requiring additional spares
3. Lead time required to procure additional units
4. Impact to program if spare is not available when required

The cost of additional spares is usually known firmly only when the initial procurement is made, unless the price of additional units, to be procured later, is written into the purchase contract. The probability of requiring additional spares may be estimated from the expression

Total projected unit operating time

2 (MTBF X No of spares)

The degree of conservatism that is adopted must be based upon the impact to the program if a replacement component is unavailable for the projected lead time.

7.0 SYSTEM INTEGRATION AND TEST

There are two ways in which a complex system may be integrated and tested. One approach is to build and assemble a complete system and hope that it works. The other possibility is to organize a step-by-step progression of tests of increasing complexity, with each test building upon the results of the previous test.

The put-it-all-together-and-try-it-approach is attractive and cost effective if it can be done inexpensively and with low risk. No complex system has ever been known to work at first trial, however, and a high-performance propulsion system requires a very costly test facility. Trouble shooting during facility occupancy is notoriously expensive. Furthermore there is a finite and increasing probability that a minor flaw would cause destruction of the test article and extensive damage to the test facility.

Under the circumstances we strongly support the step-by-step approach. Our recommendations relative to the planning and execution of system integration and test activities are given below.

7.1 INTEGRATION PHILOSOPHY - THE STEP-BY-STEP APPROACH

The integration and test philosophy recommended for propulsion controls on a high-performance aircraft is diagrammed in Figure 7.1-1. The sequence shown is essentially that followed during the IPCS program, with some additional steps that would be required if a complex inlet were used on the aircraft.

Interface tests would be initiated by the controls vendor as soon as the hardware and software components become available. Specimens of each type of engine and inlet sensor and electromechanical or electrohydraulic component should be supplied by the engine and airframe manufacturers. The ability of the electronics to excite the transducers and condition the signals must be demonstrated. The ability of the electronics to interface with the actuators - drive stepper motors, solenoids, etc - should also be demonstrated at this time.

Final pre-delivery checkout will be performed on the actual control computer with its interface unit, using a real-time simulation to close the loop as discussed in Section 5.0.

At least two sets of electronic hardware should be supplied for the subsystem tests. The IPCS fuel bench test procedure is basically sound and is adaptable to other programs. In addition, a closed-loop wind-tunnel test of a fully actuated inlet model is recommended, particularly if the inlet operates in a mixed-compression mode. The scale of this model should be as large as required to reproduce full-scale geometry and Reynolds number effects with fidelity. A 1/6 - scale model is probably a reasonable minimum size.

Sea-level-static testing of the demonstrator engine would probably be initiated using a bell-mouth inlet. The introduction of a boiler-plate version of a flight inlet during the sea level test program is desirable, however, particularly if the inlet is actuated during ground or low speed flight operation.

An altitude test and full scale wind tunnel test of a complete propulsion module are shown to complete the integration test program. The decision of whether to perform the altitude test during the demonstrator program must be evaluated on a case by case basis. The full scale wind tunnel test should probably be deferred to the prototype program.

7.2 TEST REQUIREMENTS

The key to establishing the specific test requirements is to identify the test events needed to assure suitability for flight. This requires a plan that focuses attention on the various components and subsystems to be tested to permit a timely sequence of events that build upon each other. Each test event builds up to the next test event that uses more of the system. Thus each test acts as a building block for the next test up to the point of certification. Once the test sequence is established, detailed test plans for each are written to establish the test events, requirements, schedules, limits, and acceptance criteria.

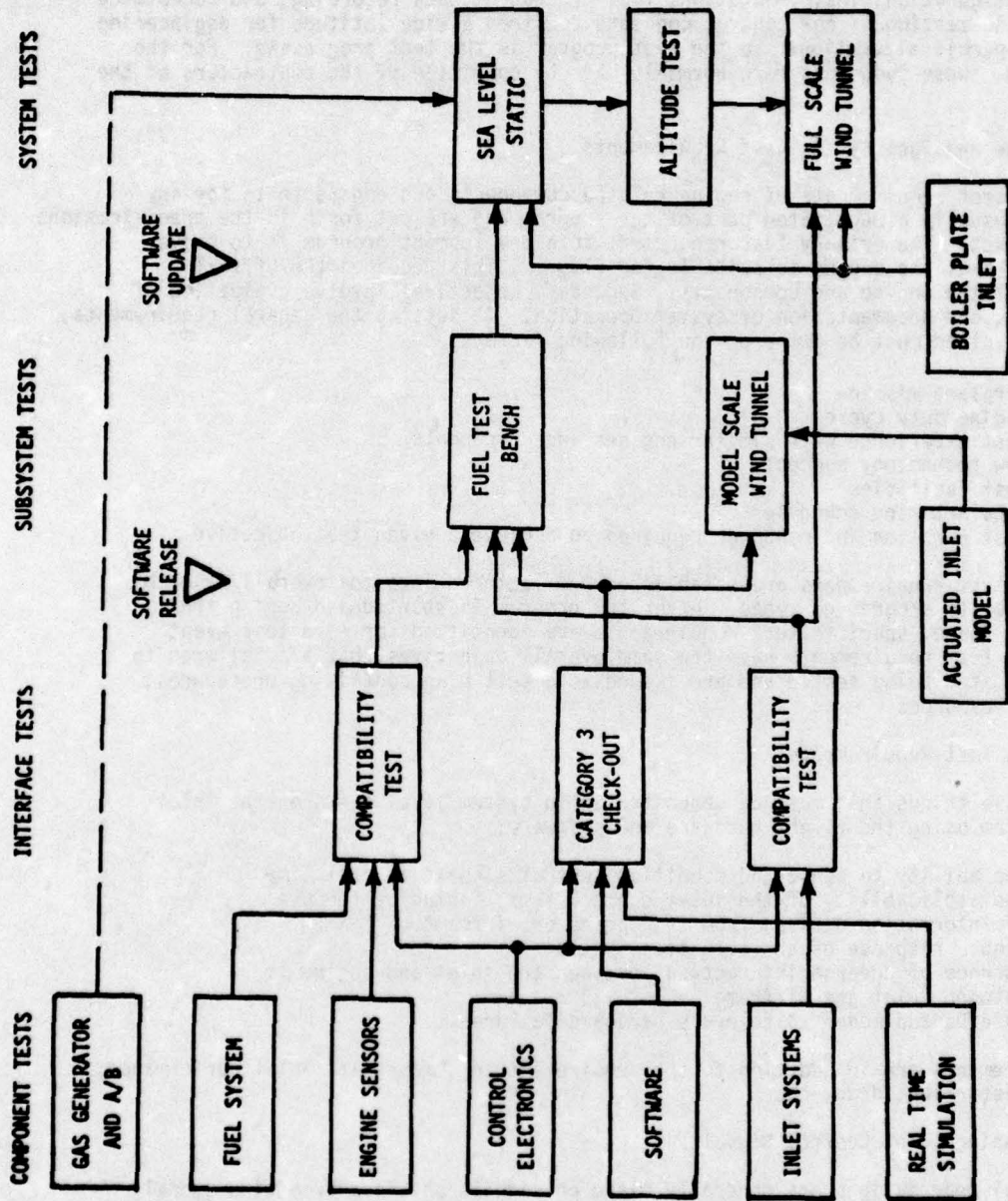

Figure 7.1-1 Step-by-Step Integration and Test

The component test requirements for the IPCS program were identified in Flight Assurance Test Plans that outlined all of the inlet, fuel system, and engine changes and electronic components and how they were to be tested. The tests included individual component open loop bench testing, vibration testing, system closed loop bench testing, and full scale engine testing under both sea level and altitude conditions. Each test event was conducted with a test plan which identified the test hardware, the facility, the test configuration, instrumentation, test procedure, data recording, and acceptance criteria. The testing of new control concepts required a wide latitude for engineering judgment to permit alterations to the test program as the test progressed. For the IPCS program, these judgments were normally made by committee of the contractors at the test site.

7.2.1 Engine and Fuel System Test Requirements

The general test requirements of engine related components and engine tests for any program are usually a negotiated part of the program and are set forth in the specifications of the contract. The primary test requirement in a development program is to prove through test that the engine is suitable for flight. This requires the official acceptance of the engine and components. Secondary objectives involve evaluation of new concepts, and documentation of system operation. In setting the general requirements, personnel involved must be aware of the following factors:

1. Airplane mission
2. Engine duty cycle
3. Past experience with similar engines and components
4. New technology concepts
5. Test facilities
6. Manufacturing schedules
7. Test duration and manpower required to achieve a given test objective.

The general test requirements are established and factored into the overall program schedule prior to program go ahead. After the program is started and during the Final Design Phase, specific test requirements are identified for each test event. The specific test requirements have the same overall objectives, but are tailored to the specific item being tested and are issued as a test plan containing procedures, limits, and resources.

7.2.2 Inlet Test Requirements

There are five things that must be demonstrated in system level tests of the inlet control system using the flight hardware and software:

1. The ability to sense and condition control signals in real time.
2. The applicability of the inlet control laws, including the use of information derived from the engine or airframe.
3. Proper response of the actuation system.
4. Absence of adverse interactions between the inlet and engine or between inlet and airframe.
5. Safe backup modes to tolerate hardware failures.

These requirements are in addition to the requirement to demonstrate inlet performance; recovery, distortion, drag, etc.

7.2.2.1 Sensing Inlet Control Signals

Inlet control mode designs are generally based on signals obtained from wind tunnel tests of small scale models. (See paragraph 3.1.1.2 and 3.2.2.) It is important that these be corroborated both statically and dynamically using flight hardware and software. The following areas of concern should be addressed:

1. Model scale effects and manufacturing tolerances can affect the signal characteristics. This is particularly true of supersonic flow.

2. Pneumatic line dynamics can introduce both phase lag and transient errors. The transient errors are caused by differences in the responses of the static-pressure and total-pressure legs of Mach sensors. The differences may stem from differences in line configuration or from differences in probe response between the static and total pressure sides.
3. The transducer environment - temperature, vibration, and EMI - can affect the signal accuracy.
4. Signal conditioning hardware and software should be demonstrated under realistic operating conditions. Items such as counters, timers, A/D converters, calibration data, signal ranges, and scaling are amenable to bench testing. Signal noise is a potentially troublesome element that cannot be evaluated reliably without the wind tunnel or flight testing of large scale inlet hardware. (See section 3.4.3.12 for the treatment of signal noise.)

7.2.2.2 System-Level Tests of Inlet Control Laws

Ideally inlet control laws should be demonstrated in wind-tunnel tests of large-scale models under closed-loop control. (No wind tunnel tests were conducted during the IPCS program - this accounts for our timidity in modifying the bill-of-materials control mode for use with the advanced engine control modes.) If a mixed-compression inlet is used, the closed-loop wind tunnel tests should be made mandatory. If an external-compression inlet is used, the closed-loop wind tunnel tests may be eliminated if no unacceptable hazards are associated with inaccuracies in inlet surface positions.

The IPCS inlet control laws as well as the modified actuation system were tested as part of the fuel test bench operation. (Volume II, Section 6.0.) Inlet aerodynamics were simulated on an analog computer. Pressure transducers were replaced by voltage controlled oscillators (VCOs) driven by the analog inlet simulation. Engine/inlet interaction was implemented through interconnections between the analog inlet simulation and the real time hybrid engine simulation. The inlet actuators and their position feedback transducers were installed in a test fixture that simulated inertial loads but not aerodynamic loads.

The principal limit of the applicability of the IPCS bench test approach is that imposed by the fidelity and range of the engine and inlet simulation. These should be adequate to perform the following:

1. Exercise all normal and back-up inlet control loops over the entire flight envelope.
2. Investigate the effects of all significant engine-inlet interactions
3. Simulate failures of all critical components.

7.3 TEST TIMING

The integration and test timing requirements for any program are of major importance to the ultimate success and cost impact of the particular program. It is to this end that extreme thought and care should be exercised in establishing the base test schedule to be followed and also to allow for revisions to this schedule as the testing progresses.

There is, for each different program, an optimum test schedule that can be established at the outset of a program. This optimum schedule should allow for the following:

1. Sufficient test time to complete the goals established for each intended test.
2. Sufficient schedule time to allow for analysis of the test data before proceeding to the next phase of testing.
3. Flexibility in the test schedule to allow for additional testing if necessary.

To expand on item 1, a most difficult scheduling exercise at the proposal stage of a program, it should be recognized that this scheduling requirement must be an iterative process continuing to the end of the test itself. Guidelines that could be followed to meet this goal are as follows:

1. Realistic appraisal of the test time requirements based on previous experience.
2. Comprehensive test plan established as early in the program as possible.
3. Detailed schedule for each test outlining the flow of hardware and test goals.

The second item, sufficient time for analysis of data between test, is self explanatory. The tendency to sacrifice this scheduled time to make up for delays in testing or to perform additional testing must be resisted.

The third point presents a real problem when only one set of components, engine, etc. are being tested because it is not possible to schedule additional testing around the open periods created by other test schedules. This still remains, whatever the level or amount of testing, an optimum schedule criterion that should be pursued.

The major constraint to any test schedule or its flexibility is the cost impact due to delays, or additional testing. This points out the need for skilled program managers to assess the test schedule and apply sound judgement to either extension or termination from the standpoint of ultimate program success versus cost impact.

The IPCS program was involved with the integration and test timing between three companies with three different pieces of hardware. It also involved two sets of hardware from each company. Reference the test schedule, Figure 7.3-1, as an example. The original proposed test schedule was not the most workable schedule, however, the iteration process of the scheduling which took place as the program progressed resulted in a test schedule and sequence of events which was very reasonable. The test plans for each test defined the test requirements and the acceptance criteria but also allowed for flexibility in the actual test sequence to obtain the maximum utilization of test time. Also outlined in the test plan were the detailed schedule of events and their proposed completion date. This proved very useful in maintaining a test sequence in line with the time requirement. It is important that this type schedule be broken down into the smallest increments of testing possible to prevent an oversight of a test event and also to prevent lingering on one test to the point of not completing the overall test program.

The time allowed between test events for data analysis in the IPCS program was crunched because of scheduling and cost considerations. This is not desirable and should be avoided if possible. (See Section 7.4 below).

The flexibility in the IPCS test schedule was demonstrated during the sea level static engine testing. During the testing of engine P-676629 the proposed 20 hours of test time proved insufficient to complete the testing required to solve the problems that were identified during test. An extension was allowed by mutual agreement of the contractors which proved very beneficial in the ultimate success of the program even though a penalty was imposed on the scheduling and cost of the program.

7.4 TEST DATA

A digital control has the capability to output large amounts of data on engine and control operation. If properly used the data can significantly reduce the time required to identify and solve development problems. The task of processing and displaying the large quantity of data should not be underestimated.

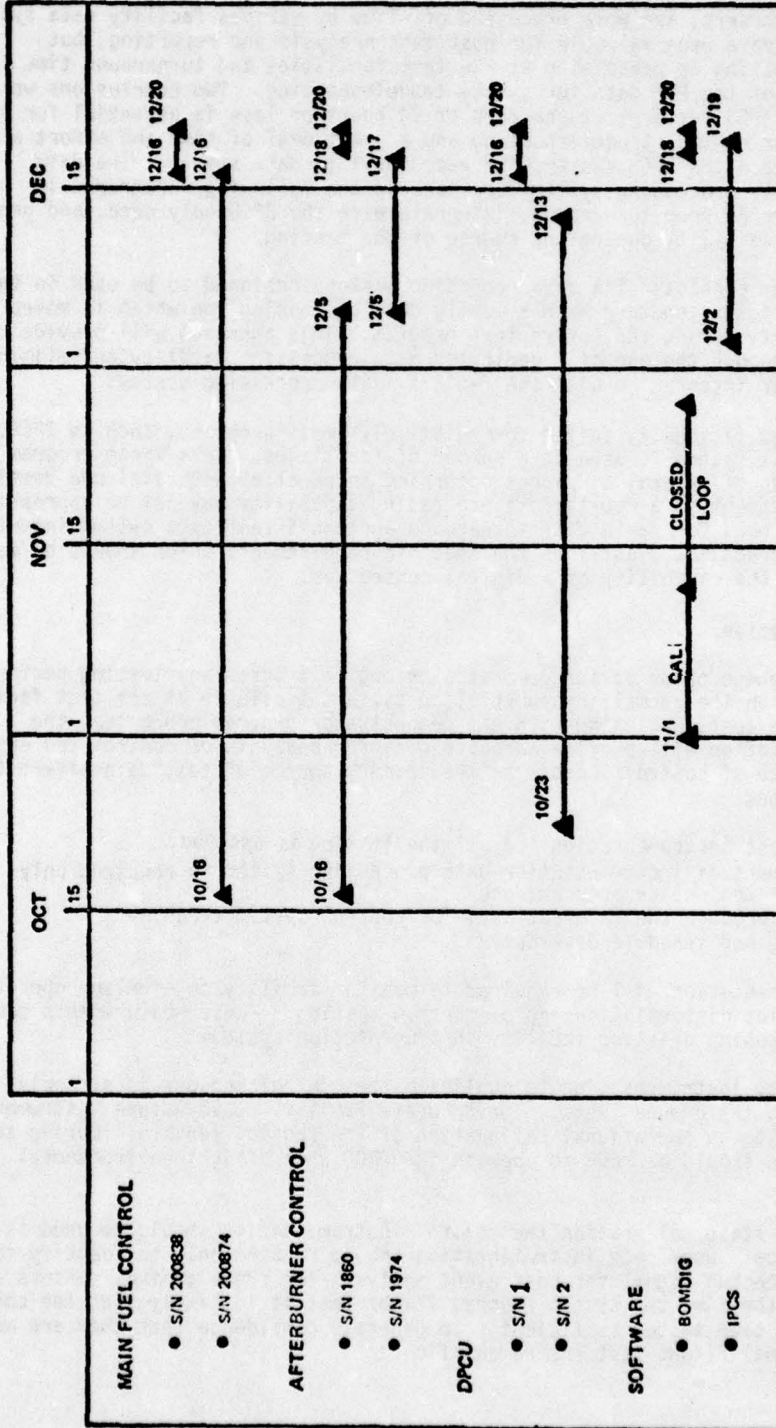

Figure 7.3-1 Test Configuration Schedule

In the IPCS program two sources of DPCU data were used - 11 channels of analog data and 59 channels of 20 sample per second PCM data. The analog data were available for on-line display on a stripchart recorder. The PCM data were displayed on-line on an octal display and stripchart recorders, and were processed off-line by various facility data systems. The processed PCM data were valuable for post test analysis and reporting, but difficulties in setting up processing at the test facilities and turnaround time largely prevented the use of the PCM data for system troubleshooting. Two conclusions were apparent from the IPCS testing: turnaround of 24 hours or less is essential for any data to be used for control troubleshooting and a great deal of time and effort are required to interface the DPCU system with each facility data system. The data acquisition and data processing system described in the following paragraphs is designed to achieve 24 hour turnaround, integrate with the DPCU only once, and provide the maximum data visibility during the course of the testing.

The proposed system consists of a data recording package designed to be used in the ground and flight tests together with a mobile data processing van which is moved from facility to facility during the entire test program. This approach will provide rapid data turnaround through the use of a dedicated data processing facility and eliminate the requirement for interfacing with the facility data processing systems.

The proposed system is ideally suited for relatively small programs, such as IPCS, in which a single test system is used at a number of facilities. In a large program with flight testing of several airplanes occurring in parallel with altitude testing of engines, the concept of a mobile data processing capability may not be appropriate. However, the same need for rapid data turnaround and consistent data system interfaces will exist. Paragraph 7.4.2 outlines the specific requirements which should be met to take advantage of the capability of a digital controller.

7.4.1 Instrumentation

During the study phase prior to the demonstrator engine program any testing performed will have to rely on the normal instrumentation systems available at the test facility. However, for those tests beginning with the demonstrator program bench test the control instrumentation will provide adequate data for analysis of control and engine operation. The use of control sensors as the primary source of test data offers the following advantages:

1. Consistent instrumentation for all the testing is assured.
2. Development of instrumentation data processing system is required only once for the entire program, and
3. it will produce the relevant data for control system troubleshooting and schedule development.

Additional instrumentation will be required to monitor facility or airplane operation and to measure inlet distortion during distortion testing. These measurements can generally be made using existing facility instrumentation systems.

The use of facility instrumentation to duplicate the control sensors is strongly recommended during the ground tests. The accurate facility steady-state instrumentation is needed to provide an operational calibration of the control sensors. During this testing provisions should be made to operate the DPCU under flight environmental conditions.

Except for steady-state calibration the control instrumentation should be used as the primary data source. Duplicate instrumentation should be used only to identify failed sensors and as a backup signal for post event analysis for those control sensors which have failed. By the time the system reaches flight test it is likely that the control sensors will have been tested sufficiently to generate confidence that they are more accurate than normal flight test instrumentation.

7.4.2 Data Recording and Processing

As a result of the IPCS experience the following data handling requirements have been defined:

1. On-line stripchart display of DPCU data including discrete bits with at least 10 bit resolution on continuous variables.
2. Turnaround of 24 hours or less on reduced data.
3. Ready availability (within 24 hours and preferably essentially on line) of plots of any selected variables.
4. Consistent data interface for all tests.

A system designed to meet these requirements is described in this section. It has been designed for a relatively small program in which testing is performed sequentially at a number of test facilities. This design may not meet the needs of all programs, but the basic data processing requirements still exist regardless of program size.

The data handling scheme, illustrated in Figure 7.4-1, was designed starting with the flight test requirements. For flight test it is necessary to have on-board data recording as well as telemetering to a ground station. At the ground station the data will be recorded again as a backup for the flight recording and displayed for on-line analysis. In flight the DPCU data would be converted from parallel to serial data, recorded, and telemetered to the ground. For ground testing on the airplane the same data handling would be used except the telemeter link would be replaced with a cable. In the ground test facilities the on board recording and transmitting would be eliminated.

The construction of two identical data recording packages would serve two purposes: spare components would be available during the flight test program and one unit could be installed along with the data processing hardware in a mobile data processing van. The van could then be used for data processing during all the ground tests and serve as a ground station during the flight tests. In this way the sometimes difficult job of interfacing between the DPCU and test facility data recording systems can be eliminated and the development of data processing software could be done once for the test program rather than done over again at each facility. The van capability described in the following paragraphs would provide good on-line display with a dedicated facility for all of the final data processing, eliminating the need for off-line processing by either the facility or the contractors. This bypasses turnaround problems frequently experienced at test facilities. Facility instrumentation used in addition to the DPCU data should be recorded on normal facility systems using a common time code for correlation.

The data recording package, Figure 7.4-2, consists of a 14 track tape recorder, a time code generator, and a converter to transform the data from the DPCU from a parallel bit stream on separate wires to a single channel of serial bit PCM data. A switching system will allow the use of the package in a record-only mode taking the converted data from the onboard package during testing with the airplane. The extra channels of the tape recorder will be used to direct record analog data available from the DPCU.

The data processing serves two purposes: on-line and quick turnaround of data for troubleshooting and test planning, and data reduction for longer term analysis and reporting. The package proposed for the data van, Figure 7.4-3, provides both of these functions. The on-line display consists of four 8 channel stripchart recorders which can take inputs from either the DPCU analog data or the PCM data processed by a decom unit and digital-to-analog converters. The PCM data are also transmitted to the mini-computer for storage on disk or tape and digital processing. Data from the computer can be selected either for printouts or for plotting on a very rapid turnaround basis for system troubleshooting. During off-hours when testing is not underway the computer can be used to print large volumes of data and write magnetic tapes for production of microfilm, if desired, for long term data storage. The plotting hard copy capability will satisfy the reporting requirements for plots. Data availability will permit visual comparison of events occurring at different times during the test. Thus of all the data processing, only the routine printing of microfilm must be done by equipment other than that which is contained in the van on-site. A similar system designed around a PDP11 was used at Boeing during the IPCS program for generating data plots. Figure 7.4-4 is an example of such a plot. Unfortunately the equipment was not dedicated to IPCS and thus was not available at the test sites.

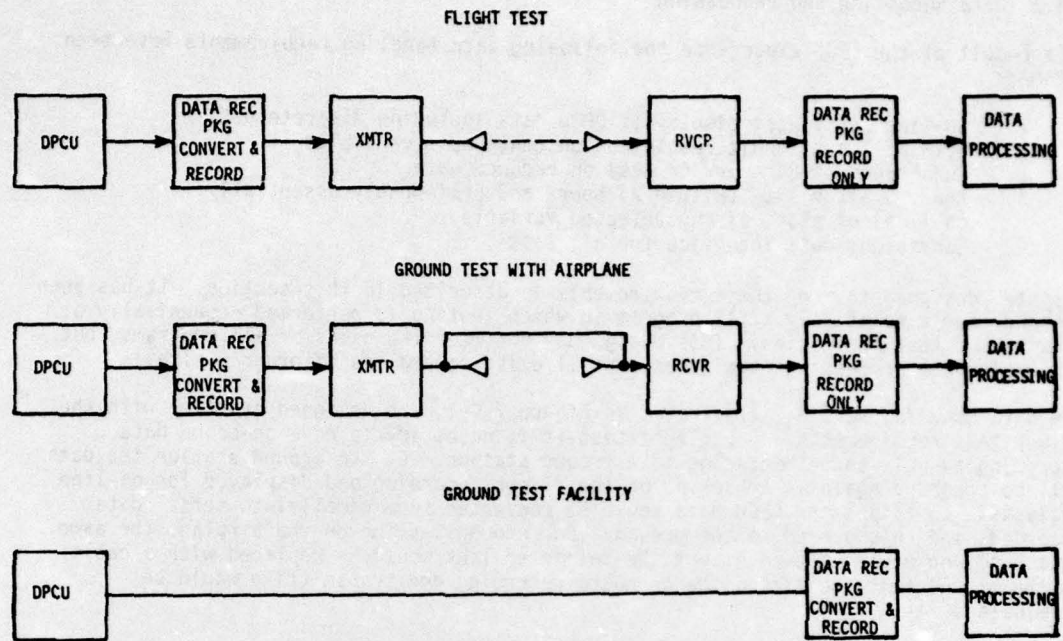

Figure 7.4-1 Data Handling Scheme

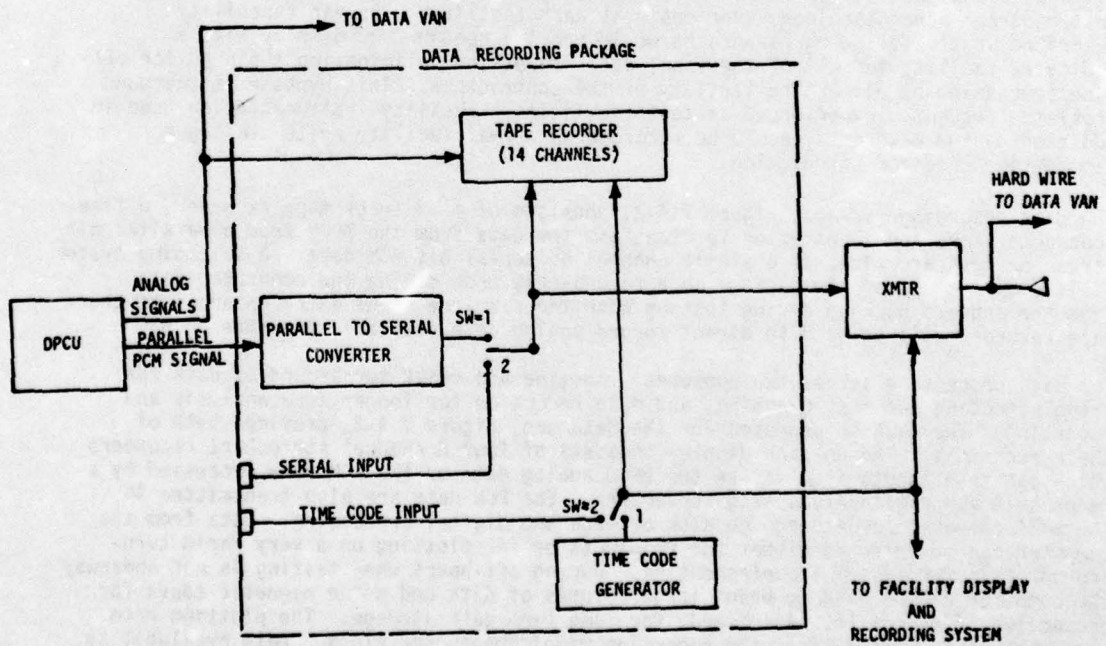

Figure 7.4-2 On-Board Data Recording

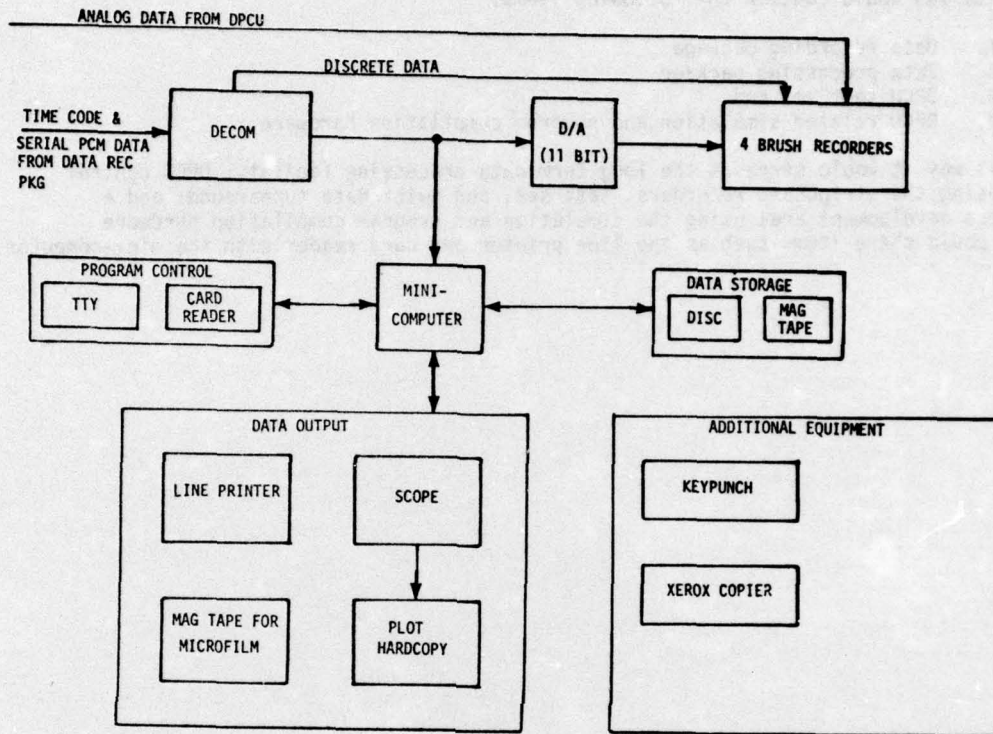

Figure 7.4-3 Data Processing Package

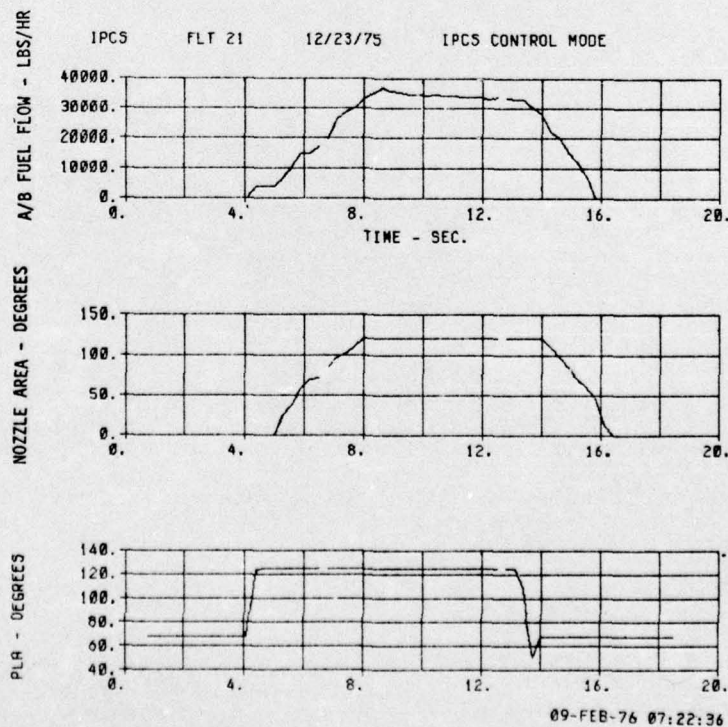

Figure 7.4-4 Typical PDP11 Machine Plot

The data van would contain the following items:

1. Data recording package
2. Data processing package
3. DPCU test set and
4. DPCU related simulation and program compilation hardware

In this way it would serve as the long term data processing facility; DPCU control room using the stripchart recorders, test set, and quick data turnaround; and a software development area using the simulation and program compilation hardware which could share items such as the line printer and card reader with the mini-computer.

8.0 REFERENCES

1. Brimelow, et al., Techniques for Establishing Propulsion System Stability, Technical Memorandum APTA TM-69-12, Project 3066, Wright-Patterson AFB (1969).
2. Billig, L. O., Automatic Detection and Suppression of Inlet Buzz, Progress in Astronautics and Aeronautics, 34, (Instrumentation for Airbreathing Propulsion) MIT Press, Cambridge, Massachusetts and London, England (1973).
3. Willoh, R. G., A Mathematical Analysis of Supersonic Inlet Dynamics, NASA TN D-4969, Lewis Research Center, Cleveland, Ohio (1969).
4. Wilberg, Donald M., "State Space & Linear Systems" Schamm's Outline Series (1971).
5. Wilkinson, "The Algebraic Eigenvalue Problem" Oxford, The Clarendon Press
6. Patel, R. V., "On the Computation of Numerators of Transfer Functions of Linear Systems" IEEE Transactions on Auto Control, August 1973 pp 400.
7. Davison, E. G., "A Computational Method for Finding the Zeros of a Multivariable Linear Time Invariant System" Automatica Vol 6 May 1970.