

AD-A033 095

OREGON STATE UNIV CORVALLIS SCHOOL OF OCEANOGRAPHY
EXPOSURE. A NEWSLETTER FOR OCEAN TECHNOLOGISTS. VOLUME 4, NUMBE--ETC(U)
NOV 76 R MESECAR

F/G 13/10
N00014-67-A-0369-0007
NL

UNCLASSIFIED

| OF |
AD
A033095

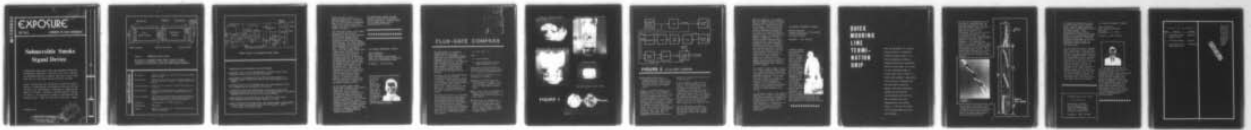

END

DATE

FILMED

1 - 77

AD A 088095

EXPOSURE

vol. 4 no. 5

a newsletter for ocean technologists

Submersible Smoke Signal Device

A submersible smoke signal device was designed at Woods Hole Oceanographic Institution (June 1975) as an aid in recovering subsurface moorings by making them easy to sight when they return to the surface several miles from the ship.

Thirty seconds after the mooring has reached the water's surface, a smoke grenade is ignited that blows off the top end cap of the smoke signal's container and generates red smoke for 1 minute. As shown in the cross-section drawing in Figure 1, the top end cap is held in place only by snug fitting O-rings. When the end cap is blown off, a short

November 1976

DISTRIBUTION STATEMENT A
Approved for public release;
Distribution Unlimited

DDDC
RECEIVED
DEC 8 1976
C

1473

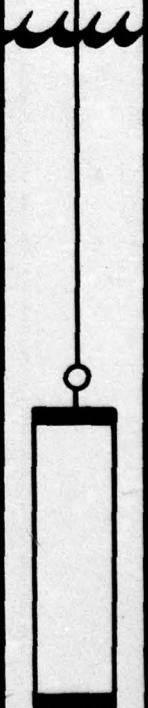

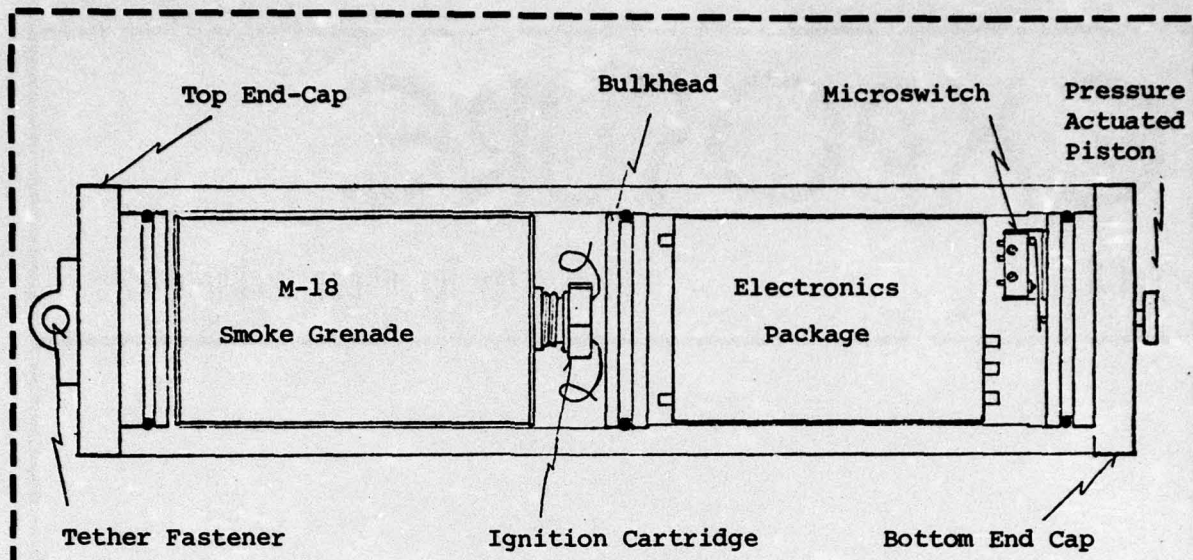
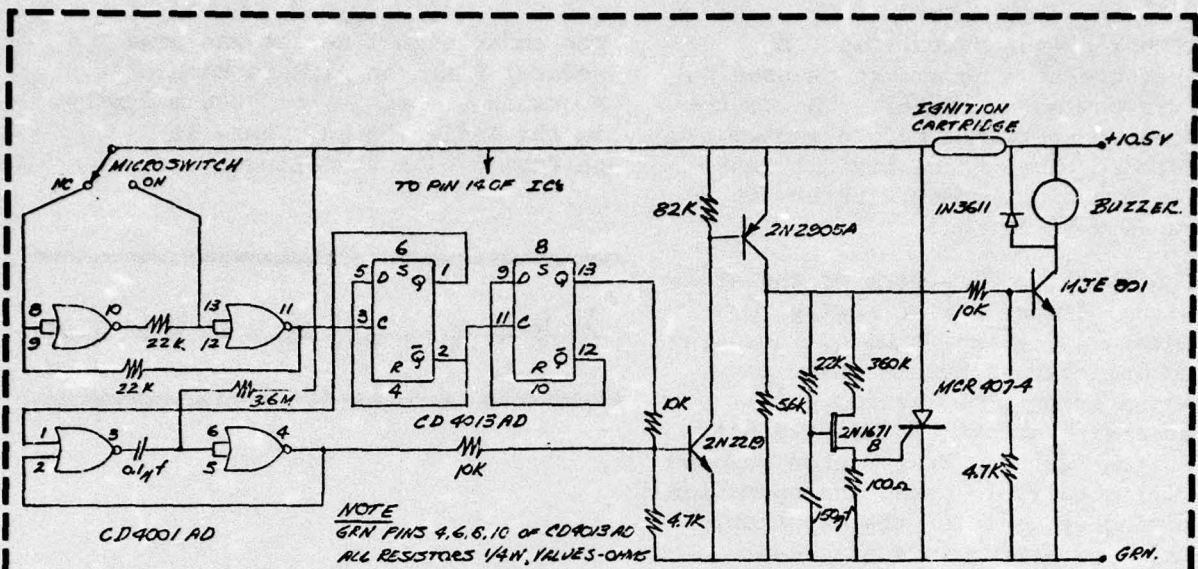

Figure 1. SUBMERSIBLE SMOKE SIGNAL

Not shown is a doughnut-shaped spacer between the smoke grenade and the bulkhead. Also, the electronics package is connected to the bottom end cap with three screws and spacers.

specifications

Electronics:	Cosmos IC programs timer and firing circuit plus audible status indicator.
Surface Sensor:	Pressure actuated piston driving a SPDT microswitch, 65 PSIG "in" and "out" at 35 PSIG. Is integral part of the end cap.
Ignition Cartridge:	Horex model 1395, generates 10-inch flame and 900 PSIG in 10 cm ³ .
Smoke Generator:	GFE military M-18 smoke grenade. Standard color, red (available in other colors). Generates smoke for 1 minute.
Case Construction:	Hard anodized and painted 6061-T6 aluminum tube and end caps with O-ring seals. Watertight and pressure-proof bulkhead between electronics and smoke generator.
Dimensions:	3¼ inch diameter, 14 inches long overall.
Depth Rating:	5500 meters.
Battery:	Seven size AA alkaline cells. Service life more than 1 year while underwater.



DESCRIPTION OF THE ELECTRONIC CIRCUIT FUNCTIONS:

- Sections C and D of the CD4001AD make a latching circuit which prevents contact bounce from the microswitch.
- The counter, consisting of FF1 and FF2, which are sections of CD4013AD, counts microswitch closures from the latching circuit output.
- Sections A and B of the CD4001AD make up a pulse generator which is triggered by the Q1 output of the counter.
- Transistors 2N2219 and 2N2905A form an electronic switch which provides power to transistor 2N1671B, the 30-second timer, and control operation of MJE 801 to turn on the internal buzzer.
- The 30-second timer triggers the SCR, MCR 407-4, which shorts the ignition cartridge to ground, causing it to fire.
- When the ignition cartridge fires, the supply voltage is interrupted to the control circuit and the MJE 801 is turned off. After firing, there is no battery drain.

tether prevents its loss. A pressure-sensing switch is used to fire the smoke signal. The device does not activate before submerging because the control circuit must sense a high pressure before it is capable of firing.

The operational status of the smoke signal device can be easily determined at any time by listening to an internal buzzer that is actuated by a depressing and releasing stroke of the external switch piston. Four piston strokes will completely cycle the operational timing sequence of the electronic unit. Starting in a quiescent state, the first piston stroke gives a short buzz, indicating it is armed and ready for launching. A second piston stroke causes a continuous buzz and the ignititon cartridge would fire in 30 seconds if the pressure switch piston was not pushed two more times to bring the timing sequence back to the quiescent state. There will be no buzz when the electronics is inoperative, the smoke grenade has not been installed, or after the smoke grenade has been fired. Prior to installing the smoke grenade, an electrical test is made to confirm the timing status of the electronics to prevent an accidental grenade prefire.

An earlier model smoke signal device used a diaphragm type pressure sensor that was found to be unreliable. Also, potential corrosion problems existed because the pressure sensor was made of stainless steel and the external housing was aluminum. All available sensors seemed to have similar problems so another pressure sensing design was done of aluminum and was included into the end cap instead of being a separate component. This design uses a loaded piston to actuate a microswitch.

The smoke signal device was used several times on Richard Koehler's Acoustic Dropsonde, to 5000 m depths, in the Indian Ocean, where it performed without failure.



FOR FURTHER INFORMATION, CONTACT:

Harold Armstrong
Buoy Laboratory
Dept. of Physical Oceanography
Woods Hole Oceanographic Institution
Woods Hole, Massachusetts 02543

Telephone: (617) 548-1400

Harold Armstrong has been employed at W.H.O.I. since 1962. He is a Senior Research Assistant in the Buoy Laboratory and is currently involved with the servicing and deployment of current meters for the Polymode Program.



Flux-Gate Compass Assembly

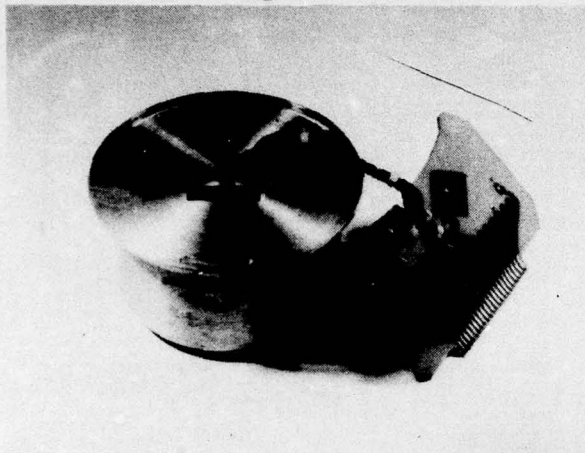

Flux-Gate Compass on Current Meter

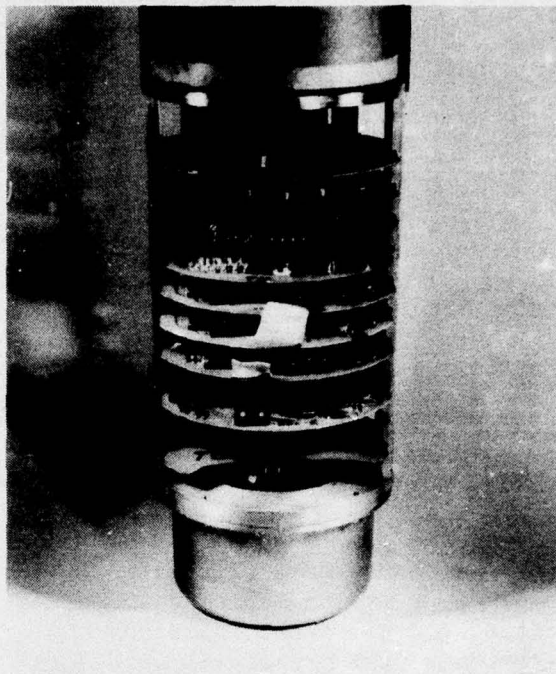

Flux-Gate Compass With Cover Removed

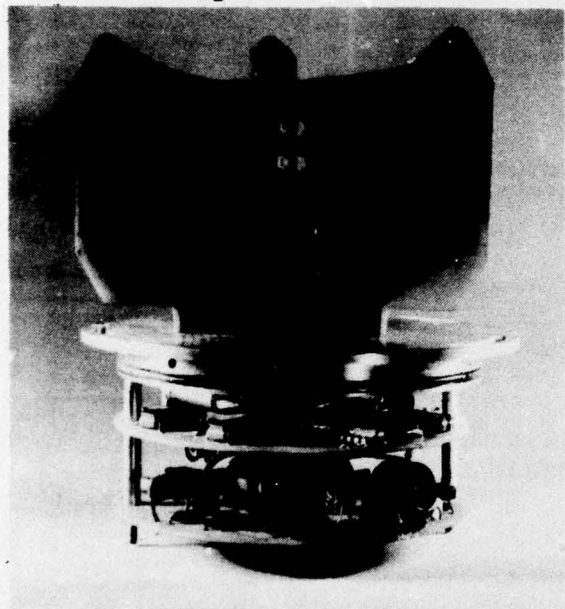

Flux-Gate Sensor

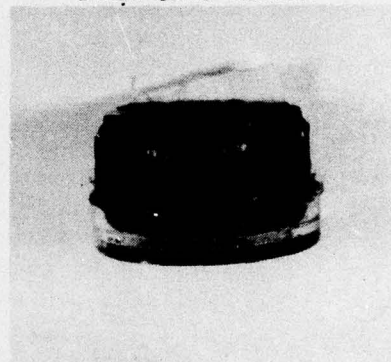

Flux-Gate Compass Circuit Cards

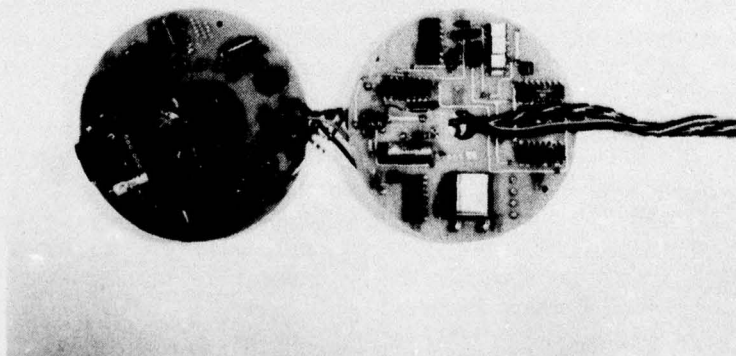

FIGURE 1.

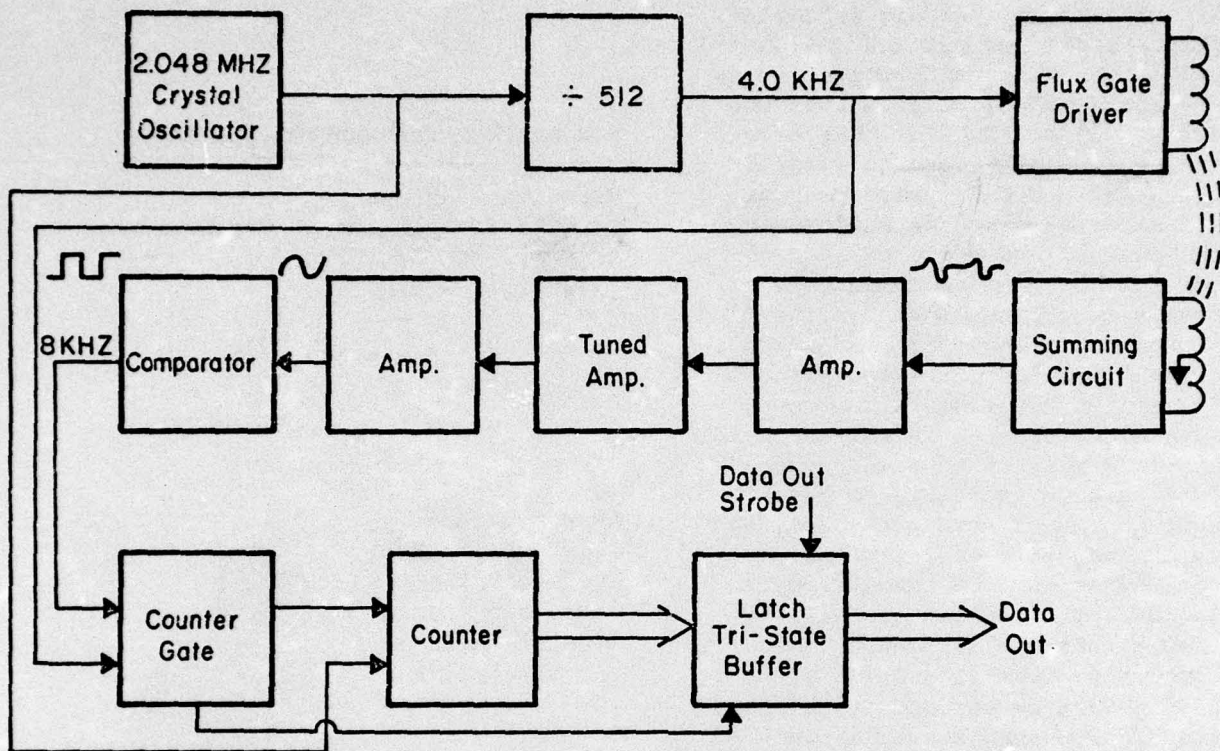

FIGURE 2. FLUX GATE COMPASS

- The stored reading may be transferred at any time (via a tristate output) by applying the "Data Out" strobe. This reading is held until the next reading cycle.

Figure 2 is a block diagram of the compass circuit. The 2.048 MHz oscillator output clocks the counter used for the phase measurement. It is also divided by 512 to provide the 4 kHz signal to drive the toroid primary. The two secondary outputs are combined in the summing circuit to produce the signal mentioned above. This signal is amplified and filtered by the next three stages to produce a clean, high amplitude sinusoidal wave form. The comparator then converts this to a

square wave suitable for driving the following logic.

A phase reading is made once each cycle of the 4 kHz signal by the counter. The counter gate starts the counter on the positive transition of the 4 kHz and stops it on the positive transition of the comparator output. Once the counter has stopped, the counter gate latches the data into the buffer. A compass bearing of 258.6° will produce a count of 225, so the output has a least significant bit weight of 1.4° .

The one shot maintains power to the high-current stages for 20 ms. The counter, counter gate, latch, and one shot comprise the standby circuitry.

After the compasses are assembled, they are checked out and calibrated. Typical overall calibration errors are about $\pm 3^\circ$ of bearing over the entire range. Much of this error is non-linearity, due to magnetic effect of component placement on the electronic boards surrounding the sensor, and could be reduced by careful movement of components or magnetic compensation. In the process of going from hand-wired circuit boards to printed circuit assemblies, very small component movements resulted in increases in non-linearity of several degrees. Care must be exercised to be sure that the exact same parts are used as the magnetic effect of all components must be considered in layout. The typical overall temperature coefficient of the compass is less than 0.1 degrees of bearing change per degree Celsius temperature change over a range of 0 to 30° Celsius.

The overall compass package results in a compact, moderate power, rugged unit. The elimination of bearings and magnets has overcome most of the problems encountered with our past mechanical compasses. Since the flux-gate sensor is designed to be part of an aircraft-deployed sonabuoy, it is inherently very rugged. To date we have experienced no mechanical problems with this compass in either shipment or at sea use.

In the future we plan to use magnetic compensation to reduce local magnetic error due to component placement and further reduce on-power consumption by improved drive circuit and amplifier design. A modification is also planned to give component outputs of direction for a vector measuring current meter under development.

FOR FURTHER INFORMATION, CONTACT:

Meredith Sessions
Scripps Institution of Oceanography
Post Office Box 1529
La Jolla, CA 92037

Telephone: (714) 452-3032

Meredith Sessions is a Development Engineer at Scripps Institution of Oceanography. He has been involved in the design of oceanographic instruments and mooring systems for the past 17 years at Scripps. He is presently engaged in the development of current meters, an automatic coastal wave monitoring system, equatorial current measurements, and operating a program to measure synoptic temperature sections in the North Pacific Ocean utilizing aircraft-expendable bathythermographs deployed from U.S. Navy fleet aircraft.



QUICK MOORING LINE TERMI- NATION GRIP

After the deployment of a bottom-anchored surface or subsurface suspended mooring system, it is often advantageous to have an expedient mooring line termination method once the anchor is in place. For many traditional types of mooring lines, such as single or hollow braid synthetic ropes, quick line termination techniques have been developed and applied. However, equivalent termination capabilities for parallel lay-constructed lines have not been available that do not compromise the line-loading factor. It was for this reason that the Quick Termination Grip was developed.

The rope to be terminated was 1/4-inch dacron, manufactured by the Columbian Rope Company under the trade name NOLARO. This rope was selected for our particular application because it is nontorquing, will not kink, and has a low elongation factor. The construction of this rope consists of equally tensioned parallel dacron fibers in a low-twist yarn. Depending on the required rope diameter, a suitable number of these yarns are bundled in parallel under equal tension and then protected by an extruded plastic jacket. This construction technique permits about 70-75 percent utilization of the fiber strength with minimum internal abrasion.

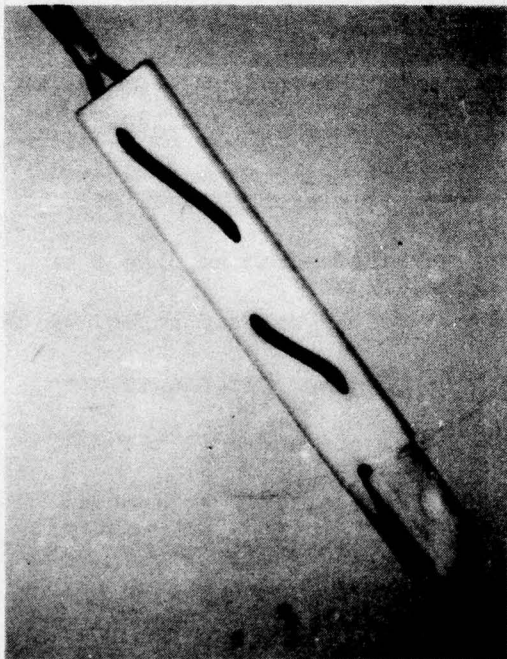
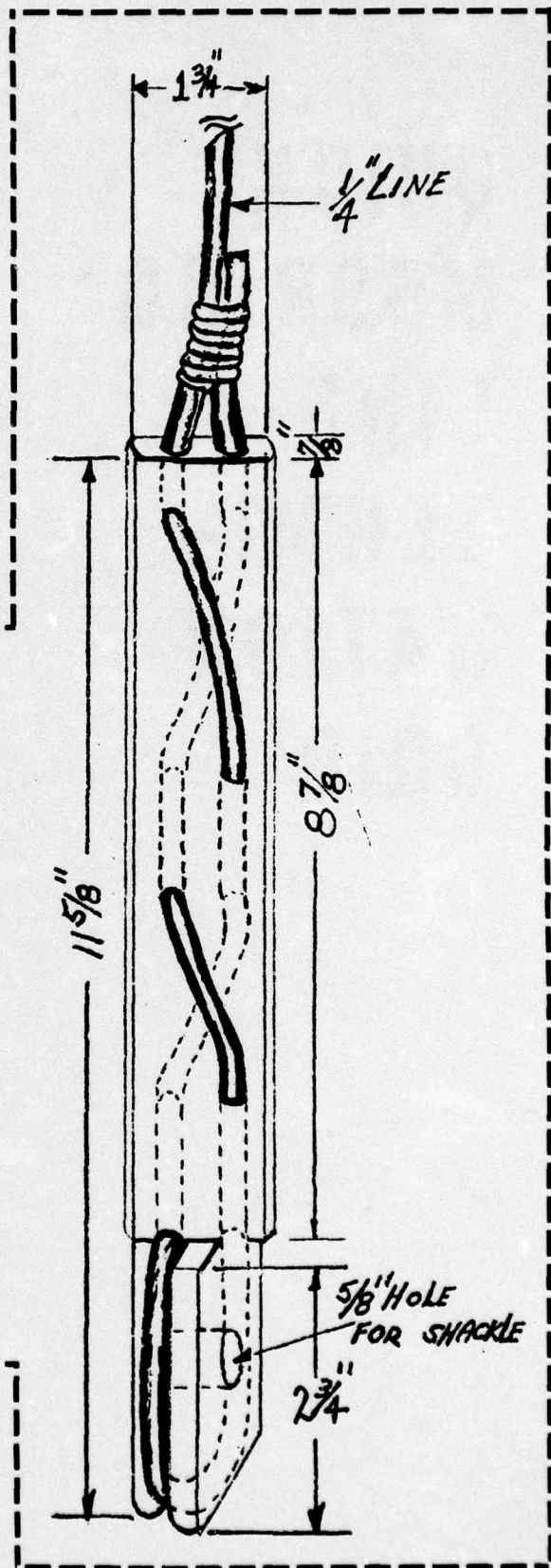

FIGURE 1.

For the best utilization of dacron fiber strength, the manufacturer recommends an eye splice termination at each end which can be factory made or by anyone experienced in splicing conventional rope.



An alternative termination method is using a socket with a casting resin. Both of these termination methods were unacceptable because of the time required. Other termination methods, quickly applicable for a modest line-loading factor, are a double-ended Chinese finger or Kellem grip. The Quick Termination Grip makes use of these principles without losing the termination integrity when the line goes slack.

The grip shown in Figure 1 was made from 12-inch long, 2-inch diameter nylon round stock. Nylon was chosen because it is easy to machine and had the required strength. The grip was constructed to give a straight penetration of the cable from the thimble part of the grip at one end into the friction section. By weaving the rope in and out at varying angles, enough friction is applied to all surface areas to insure strength for the rated load. The 1/4-inch dacron line is rated at 2100 lb breaking strength. In all tests using the nylon Quick Termination Grip, the cable parted at or above the rated strength.

FOR FURTHER INFORMATION, CONTACT:

Dario Ciuffetelli
Naval Research Laboratory
Code 8140
Washington, D.C. 20390

Telephone: (202) 767-3040

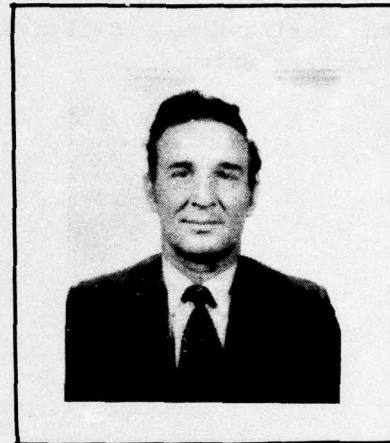

Dario Ciuffetelli was formerly a Research Assistant to Dr. T. Pochapsky at the Columbia University Hudson Laboratory, where he was associated with internal wave studies and the search for the submarine THRESHER. After moving to the Engineering Branch of the Naval Research Laboratory, he worked with the Ambient Noise Buoy Program and, for the past three years, he has been involved in the development program for the Moored Environmental Profiles System.

To submit copy or get on the

EXPOSURE

mailing list, contact:
Dr. Rod Mesecar, Editor
School of Oceanography
Oregon State University
Corvallis, Oregon 97331

Telephone: (503) 754-2206



T A B L E O F C O N T E N T S

Page	Article	Author
1	Submersible Smoke Signal Device	Armstrong
5	Flux-Gate Compass	Sessions
9	Quick Mooring Line Termination Grip	Ciuffetelli

EXPOSURE
Rod Mesecar, Editor
School of Oceanography
Oregon State University
Corvallis, Oregon 97331

FIRST CLASS MAIL

REPORT DOCUMENTATION PAGE		READ INSTRUCTIONS BEFORE COMPLETING FORM
1. REPORT NUMBER Vol. 4 No. 5	2. GOVT ACCESSION NO.	3. RECIPIENT'S CATALOG NUMBER
4. TITLE (and Subtitle) EXPOSURE. A newsletter for ocean technologists. Volume 4, Number 5.	5. TYPE OF REPORT & PERIOD COVERED ⑦ technical report.	
7. AUTHOR(s) ⑩ Dr. Roderick Mesecar (Ed.)	6. PERFORMING ORG. REPORT NUMBER	8. CONTRACT OR GRANT NUMBER(s)
9. PERFORMING ORGANIZATION NAME AND ADDRESS School of Oceanography, Oregon State University Corvallis, OR 97331	10. PROGRAM ELEMENT, PROJECT, TASK AREA & WORK UNIT NUMBERS NR 083-102	11. REPORT DATE ⑪ November 1976
11. CONTROLLING OFFICE NAME AND ADDRESS NORDA, NSTL Bay St. Louis, MS 39520 Attn: Code 410	12. REPORT DATE	13. NUMBER OF PAGES 12
14. MONITORING AGENCY NAME & ADDRESS (if different from Controlling Office) ⑫ 13p.	15. SECURITY CLASS. (of this report) (U)	15a. DECLASSIFICATION/DOWNGRADING SCHEDULE
16. DISTRIBUTION STATEMENT (of this Report) Approved for public release; distribution unlimited		
17. DISTRIBUTION STATEMENT (of the abstract entered in Block 20, if different from Report) Vol 4 no 4 - A030 600		
18. SUPPLEMENTARY NOTES Published every two months by the School of Oceanography, Oregon State University, Corvallis, Oregon 97331		
19. KEY WORDS (Continue on reverse side if necessary and identify by block number) Ocean technology; instrumentation This report describes the development of a		
20. ABSTRACT (Continue on reverse side if necessary and identify by block number) Submersible Smoke Signal Device, Flux-gate Compass, and Quick Mooring Line Termination Grip.		