

AD-A033 115

ARMY ELECTRONICS COMMAND FORT MONMOUTH N J
A 60 GHZ DIGITAL FM SIMPLEX SYSTEM.(U)
SEP 76 E FLIEGLER
ECOM-4434

F/G 17/2.1

UNCLASSIFIED

NL

| OF |

AD
A033115



END

DATE
FILMED
1-77



12
J

ADA 033115

Research and Development Technical Report
ECOM - 4434

A 60 GHz DIGITAL FM SIMPLEX SYSTEM

DDC
DEC 8 1976
C

Emanuel Fliegler
ADV TECH TEAM, MTA COMM / ADP LABORATORY

September 1976

DISTRIBUTION STATEMENT
Approved for public release;
distribution unlimited.

ECOM

US ARMY ELECTRONICS COMMAND FORT MONMOUTH, NEW JERSEY 07703

NOTICES

Disclaimers

The findings in this report are not to be construed as an official Department of the Army position, unless so designated by other authorized documents.

The citation of trade names and names of manufacturers in this report is not to be construed as official Government indorsement or approval of commercial products or services referenced herein.

Disposition

Destroy this report when it is no longer needed. Do not return it to the originator.

UNCLASSIFIED

SECURITY CLASSIFICATION OF THIS PAGE (When Data Entered)

REPORT DOCUMENTATION PAGE		READ INSTRUCTIONS BEFORE COMPLETING FORM
1. REPORT NUMBER ⑭ ECOM-4434	2. GOVT ACCESSION NO.	3. RECIPIENT'S CATALOG NUMBER ⑨
4. TITLE (and Subtitle) ⑤ A 60 GHz Digital FM Simplex System.		5. TYPE OF REPORT & PERIOD COVERED Final Report. July 1975-August 1976.
7. AUTHOR(s) ⑩ Emanuel/Fliegler		8. CONTRACT OR GRANT NUMBER(s)
9. PERFORMING ORGANIZATION NAME AND ADDRESS USAECOM Adv Tech Team, MITA Comm/ADP Laboratory DRSEL-NL-RM-1, Ft Monmouth, NJ 07703		10. PROGRAM ELEMENT, PROJECT, TASK AREA & WORK UNIT NUMBER ⑬ 61101A, 1T161101A91A, 09 313 C8
11. CONTROLLING OFFICE NAME AND ADDRESS Commander US Army Electronics Command DRSEL-NL-RM-1, Ft Monmouth, NJ 07703		12. REPORT DATE ⑪ September 1976
14. MONITORING AGENCY NAME & ADDRESS (if different from Controlling Office) ⑫/20p.		13. NUMBER OF PAGES 21
		15. SECURITY CLASS. (of this report) UNCLASSIFIED
16. DISTRIBUTION STATEMENT (of this Report) Approved for public release; distribution is unlimited		15a. DECLASSIFICATION/DOWNGRADING SCHEDULE N/A
17. DISTRIBUTION STATEMENT (of the abstract entered in Block 20, if different from Report) Same as 16.		
18. SUPPLEMENTARY NOTES N/A		
19. KEY WORDS (Continue on reverse side if necessary and identify by block number) Millimeter waves; FM-digital communications; Gunn oscillators, waveguide		
20. ABSTRACT (Continue on reverse side if necessary and identify by block number) A 60 GHz digital FM simplex radio utilizing waveguide is described. This system is operational and will be used as a reference to be compared with future integrated circuit and hybrid millimeter radios. A Gunn Local oscillator was developed which effects significant receiver noise reduction. Subsystem measurements show good characteristics for 1 km propagation.		

DD FORM 1 JAN 73 1473 EDITION OF 1 NOV 68 IS OBSOLETE

UNCLASSIFIED
SECURITY CLASSIFICATION OF THIS PAGE (When Data Entered)

037620 AB

UNCLASSIFIED

SECURITY CLASSIFICATION OF THIS PAGE(When Data Entered)

[A large rectangular area is completely redacted with a thick black border.]

UNCLASSIFIED

SECURITY CLASSIFICATION OF THIS PAGE(When Data Entered)

Acknowledgement

The author acknowledges the valuable assistance provided by several individuals in completing this program.

Mr. Louis A. Coryell's assistance in modifying and fabricating I.F., power supply and baseband circuitry and aiding in laboratory tests was invaluable, as was Mr. Delbert Mammen's assistance in circuit fabrication and equipment layout.

ACCESSION for		
NTIS	White Section	<input checked="" type="checkbox"/>
D C	Blue Section	<input type="checkbox"/>
UWA. STANCO		<input type="checkbox"/>
JUSTIFICATION		
BY		
DISTRIBUTION/AVAILABILITY CODES		
DISC.	AVAIL.	OR/OR SPECIAL
A		

TABLE OF CONTENTS

Introduction.....	1
Discussion.....	2
Millimeter Wave System Performance.....	11
Summary and Conclusions.....	16

ILLUSTRATIONS

Figure	Table	
1	Impatt Cavity.....	5
2	Modified Gunn Cavity.....	6
3	Gunn Oscillator Characteristics..... (Varian Diodes)	8
4	Gunn Oscillator Characteristics..... (Microwave Associates Diodes)	9
5	Gunn Oscillator Characteristics..... (Varian Model WF101A)	10
6	Digital FM Simplex Communication System.....	12
7	Rain Rate VS Rain Attenuation.....	14
8	Channel Reliability VS Rain Rate.....	15

INTRODUCTION

Millimeter wave radios provide wide band data transmission over ranges up to 5 km in clear weather (2.1 km in heavy rain) and is preferred over existing cable equipments for command post distribution and other tactical applications. Significant advantages are evident in signal hiding, transportability, faster set up/tear down time and compactness, compared to the physical and electrical vulnerability of cable. Further, communications signals propagated at 60 GHz provide ECM proof operation. Transmission is progressively attenuated by atmospheric oxygen absorption (15 dB/km), thus precluding signal overreach and jamming by remote sources.

Diminutive transceivers are now being developed using hybrid integrated circuit techniques and miniature antennas, which offer great compactness in design. These techniques portend significant reductions in transceiver costs in the near future.

This report describes the development and operation of a digital FM System operating at 60 GHz in waveguide, and significant improvements in receiver operation which have been achieved with the development of a Gunn oscillator.

This radio will be used as a reference for comparison with newly developed, state-of-the-art miniature subsystems. The overall objective is to develop an efficient, low cost digital FM transceiver operating at 60-75 GHz with data rates up to 20 Mb/s for command post distribution systems.

DISCUSSION

A 60 GHz FM simplex radio has been constructed in waveguide with substantial enhancement in receiver signal to noise characteristics. The transmitter is an FM bias modulated Impatt oscillator, which provides +18 dBm of CW power (65 mw). The modified receiver consists of a short slot hybrid balanced mixer, a 90° hybrid IF power combiner, a 60 MHz IF amplifier, FM limiter discriminator, and a newly developed Gunn local oscillator.

1. The transmitter is an FM bias modulated rf oscillator which accepts digital modulation at frequencies up to 25 MHz/sec. FM deviation is approximately 15 MHz. Slight modifications have been made on the Impatt oscillator so that an operating bias level of 205 ma has been found, which corresponds to a center frequency of 59.6 GHz. This operating point corresponds to an optimum condition for low noise reception at the receiver. Output power is +18 dBm.

2. Temperature Stabilization of Impatt Oscillator¹
The Impatt diode oscillator in the transmitter portion of the 60 GHz communication system operates at frequencies near the center of the atmospheric window. It is desirable to limit the fading of amplitudes of transmitted signals to a minimum practical level. A change of 5 GHz across the atmospheric window from 62.5 GHz to 67.5 GHz will produce a total amplitude change of 13 dB. This is a practical limit for system consideration. Under these conditions, the frequency drift of our Impatt transmitter must be limited to 5 MHz. The frequency stability of the Impatt diode oscillator is 50 MHz/°C. The temperature stabilization of the transmitter must be held to + 0.5°C or 0.9°F. This temperature stabilization tolerance falls within the practical limit of available techniques.

Experimental data collected on the Impatt oscillator operating in the laboratory at 22.3°C room ambient is as follows;

¹MOBDES Report, J. W. Christian, COL., USAR, 31 Jan 75.

COOLING CONDITIONS	IMPATT DIODE CURRENT	STABILIZED TEMPERATURE	STABILIZATION TIME	DEGREE RISE ABOVE AMBIENT
CONVECTION ONLY	235 ma	33.1 ⁰ C	20 min.	+10.8 ⁰ C
FORCED AIR 15 CFM	235.2 ma	28.0 ⁰ C	18 min.	+5.7 ⁰ C

The manufacturers rating on the Impatt diode oscillator relative to temperature operation is 0⁰C to 50⁰C. The laboratory experiment conducted above, indicated a 10.8⁰C rise above ambient with no cooling conditions other than convection from the black body radiation heat sink, which surrounds the Impatt diode cavity. This operating temperature is only 16.9⁰C below the maximum rated temperature of the device when operated in an ambient air temperature of 22.3⁰C.

Under the cooling conditions noted above, the Impatt diode oscillator could not be allowed to operate in an ambient temperature environment above 39.2⁰C or 102.5⁰F. If we impose a 5⁰C safety margin, the maximum operating temperature for the ambient air environment would be 34.2⁰C or 93.5⁰F. These operating conditions are not considered practical. If we employ forced air cooling of the Impatt diode oscillator and allow a 5⁰C safety margin, we can increase the safe operating ambient temperature to 39.3⁰C or 102.7⁰F. These conditions are only practical under controlled field testing conditions.

3. ANTENNA The transmitting and receiving antenna that is employed for the 60 GHz experimental communications system is a six inch diameter parabolic dish with a feed horn. This dish has a coupled gain of 37 dB, and a beamwidth of 2.3 degrees. Sidelobe levels are greater than 20 dB below the main lobe for each antenna, according to the manufacturers data.

4. LOCAL OSCILLATOR In order to reduce very high receiver noise figure (~ 16 dB), a new local oscillator was developed by incorporating a Gunn diode into a Hughes (Model 44096H) cavity.*

*Hughes Aircraft Co., Torrance, California.

Design particulars are as follows: Referring to Figure 1, the Impatt cavity consists of waveguide section with a stud mounted Impatt diode centrally emplaced in a position one half guidewave length away from a variably positioned waveguide short circuit.

A DC bias pin contacts the diode and forms a coaxial line perpendicular to the waveguide section. An R-F choke behind this pin effectively eliminates RF leakage out to the power supply. A step impedance transformer in front of the diode matches the 64 ohm Impatt diode impedance to the waveguide impedance.

In order to modify this cavity into a Gunn device, it was necessary to take the low Gunn diode impedance into account. Values were on the order of 12-16 ohms and some lower.

A simple conical coaxial resonator design developed by Eastman² served to provide impedance matching and proper cavity operation in conjunction with a tunable waveguide short circuit. This circuit is depicted in Figure 2. For a conical section of radial transmission line, the impedance is given approximately by: $Z_0 = 60 \theta$

Where θ is normally the angle between the top and bottom walls of the radial line, i.e. when the line forms part of the cavity structure as shown in Figure 2a. Note that the resonator includes an offset coaxial transmission line which is mutually coupled to the diode.³

To simplify the design, and avoid mutual coupling, a simple conical cap^{4,5} or disc was designed, to be placed over the diode with the dc pin fed through the disc to contact the diode.

The coaxial radial resonator circuit is shown in Figure 2b. For a 16 Ω diode impedance $\theta \approx 15^\circ$; here θ is the conical angle of the disc. The diameter of the disc is $\sim \sqrt{2}$ at 60 GHz. It was found, however, that this value had to be reduced by 20% in order to compensate for the discontinuity capacitance⁶ formed at the junction of the dc pin to the disc.

2 "Multiaxis Radial Circuit for Transferred Electron Devices," L. F. Eastman, Electronics Letters, Vol 8, No. 6, Feb 72.

3 Ibid.

4 "Resonant Cap Structures for Impatt Diodes," I.S. Groves, & D. E. Lewis, Electronics Letters, Vol 8, No. 4, Feb 72.

5 B. Fank, Varian Assoc., Palo Alto, California, Private Communications.

6 Microwave Engineers Handbook and Buyers Guide, 1966, page 97.

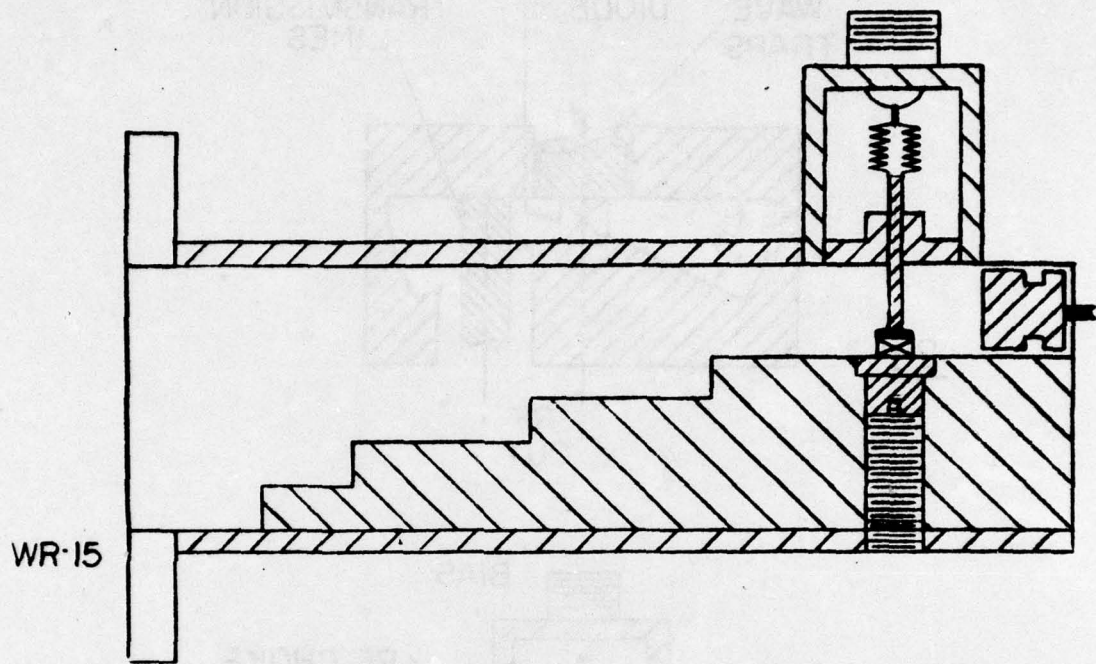

FIGURE 1

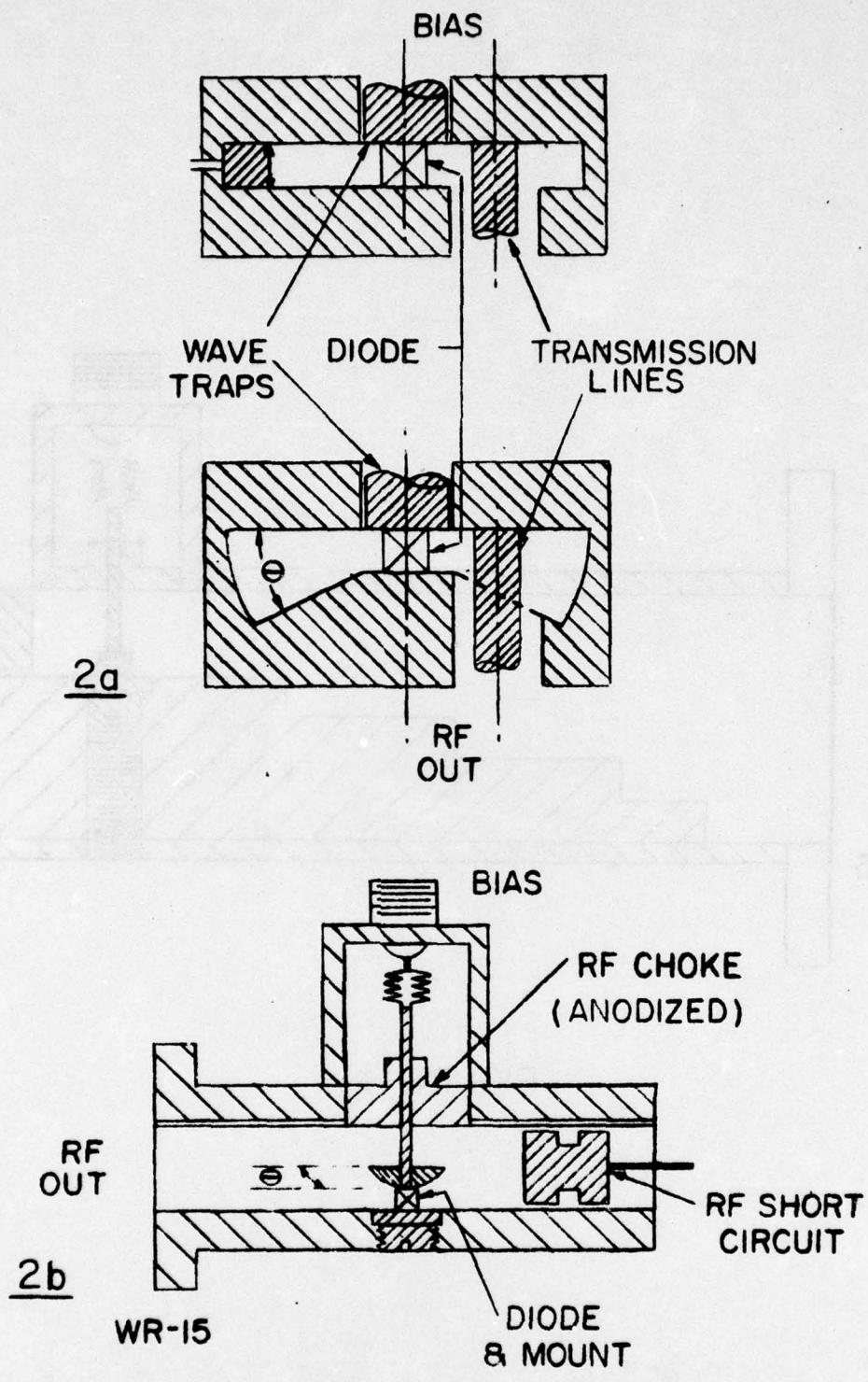

FIGURE 2

In order to match the radial resonator to the waveguide impedance and establish a wide tuning bandwidth, the vertical position of the disc along the pin as referenced to the waveguide height was critical. Several diodes were tested. Two early devices from Varian Associates each required disc emplacement $\sim .005$ from the waveguide wall above the diode, separated by a teflon dielectric. Figure 3 shows the oscillator characteristics. The characteristics for a Microwave Associates diode is shown in Figure 4. Note that this device drew high bias current; impedance matching with the resonator was very difficult and many mode jumps were encountered.

The best results were obtained using a Varian (Model WF101A) diode, and was the simplest to match to the waveguide. By placing the conical resonator directly above the diode, a 16.7% tuning range was achieved, as shown in Figure 5. This device was then used as the final reference system LO. An isolator and a variable attenuator provided low VSWR at the mixer and control of sufficient r-f power for driving the balanced mixer.

5. BALANCED MIXER A short slot hybrid combines the antenna input and the local oscillator output and divides the power equally to the two matched silicon Schottky barrier diodes, which are emplaced in their respective mounts. An OSM connector takes the mixer output to an Intermediate Frequency (IF) pre-amplifier. In order to reduce the system noise level, each mixer diode was externally biased so that the mixer could be operated in the "starved LO" condition. A power supply was fabricated, which provided (3v) 0.5 ma diode currents respectively. It was found that for microwatt levels of LO power, the minimum discernable signals (MOS) at signal=noise occurred at -79 dBm (with transmitter output =+18 dBm) compared to -69 dBm under normal LO biasing conditions. A noise figure measurement at the mixer input was 10 dB (DSB). This value takes into account the use of the Gunn LO. It was thus found that noise levels were improved by ~ 8 dB, simply by replacing the Impatt oscillator with the Gunn device.

6. I F AMPLIFIER A linear IF amplifier with 60 MHz center frequency was chosen originally, because of the availability of amplifiers and discriminators at this frequency at reasonable cost. Forty MHz bandwidth was chosen to accommodate the 20 Mb/s data rate. Using digital FM with 14 MHz of frequency shift, the bandwidth will pass 99% of the spectrum power. The 70 dB amplifier gain is ample for received signals of -70 dBm or greater. Input noise figure is 2.5 dB.

The IF amplifier has a closed loop provision built in with Automatic Gain Control (AGC) delay (about 10 m sec) to establish desired output level. AGC may be disabled and Manual Gain Control via an external potentiometer will provide 50 dB of Manual Control.

A video output of 0.5 volts (min) is provided by a direct coupled emitter follower.

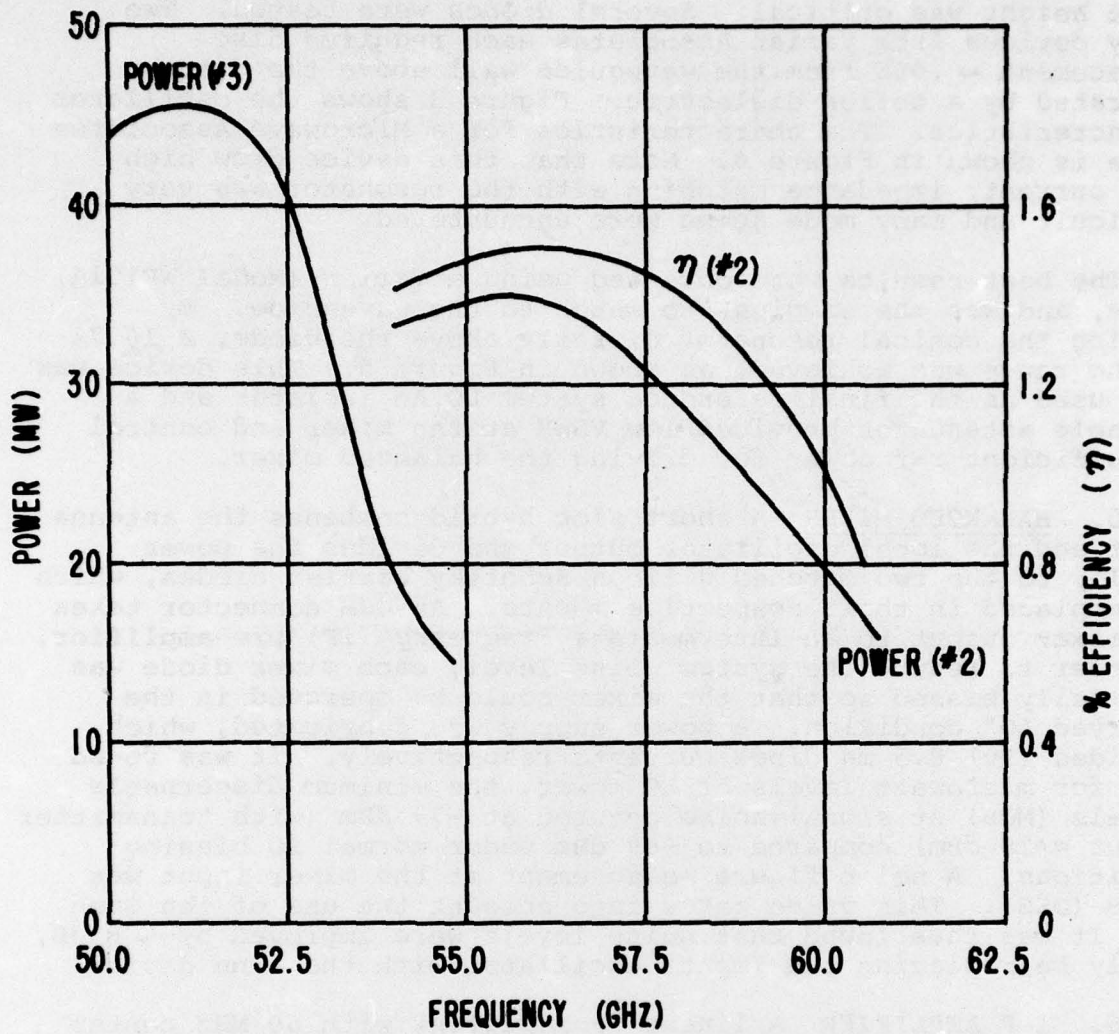

FIGURE 3. GUNN OSCILLATOR CHARACTERISTICS (VARIAN DIODES)

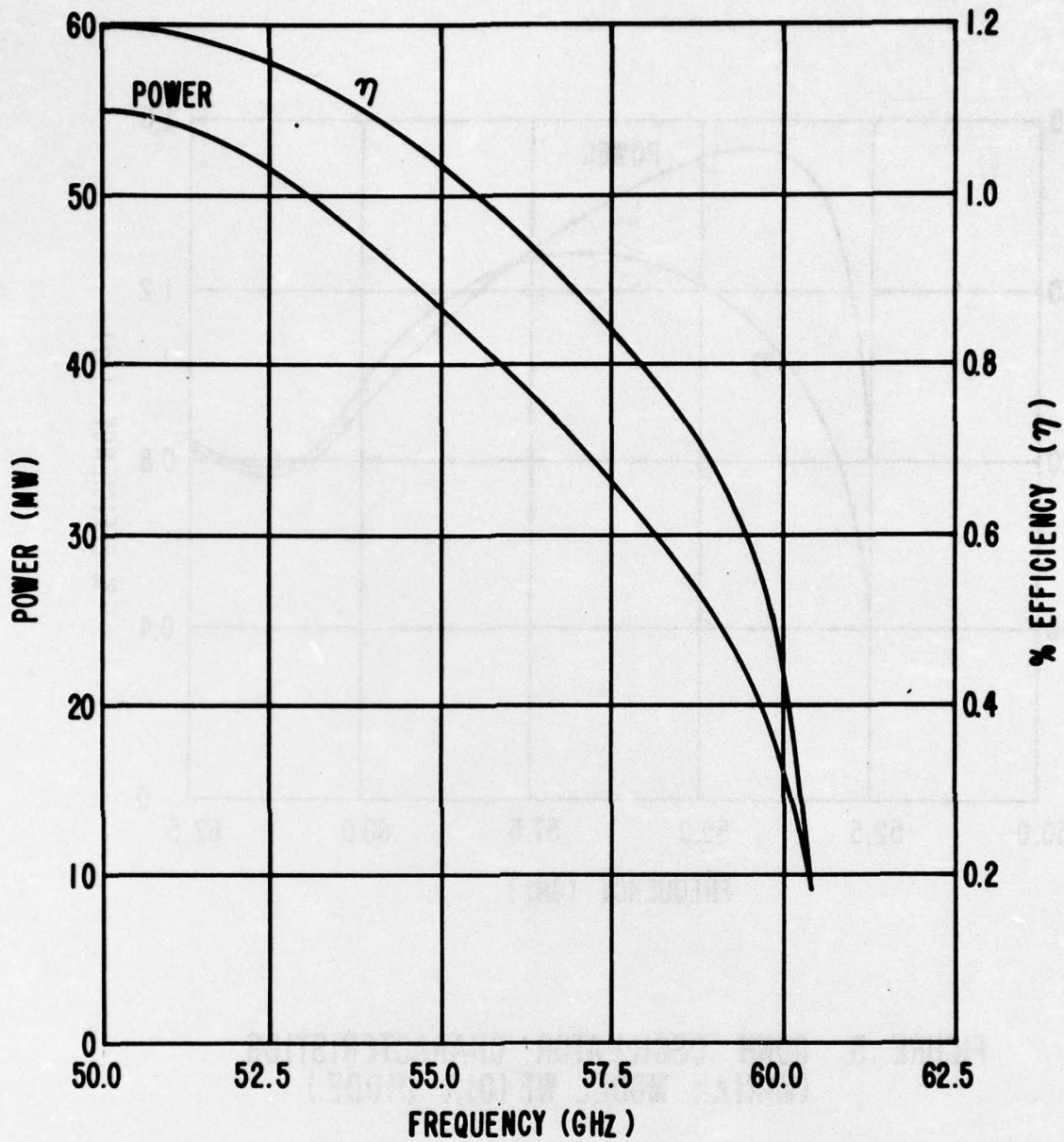

FIGURE 4. GUNN OSCILLATOR CHARACTERISTICS
(MICROWAVE ASSOCIATES DIODES)

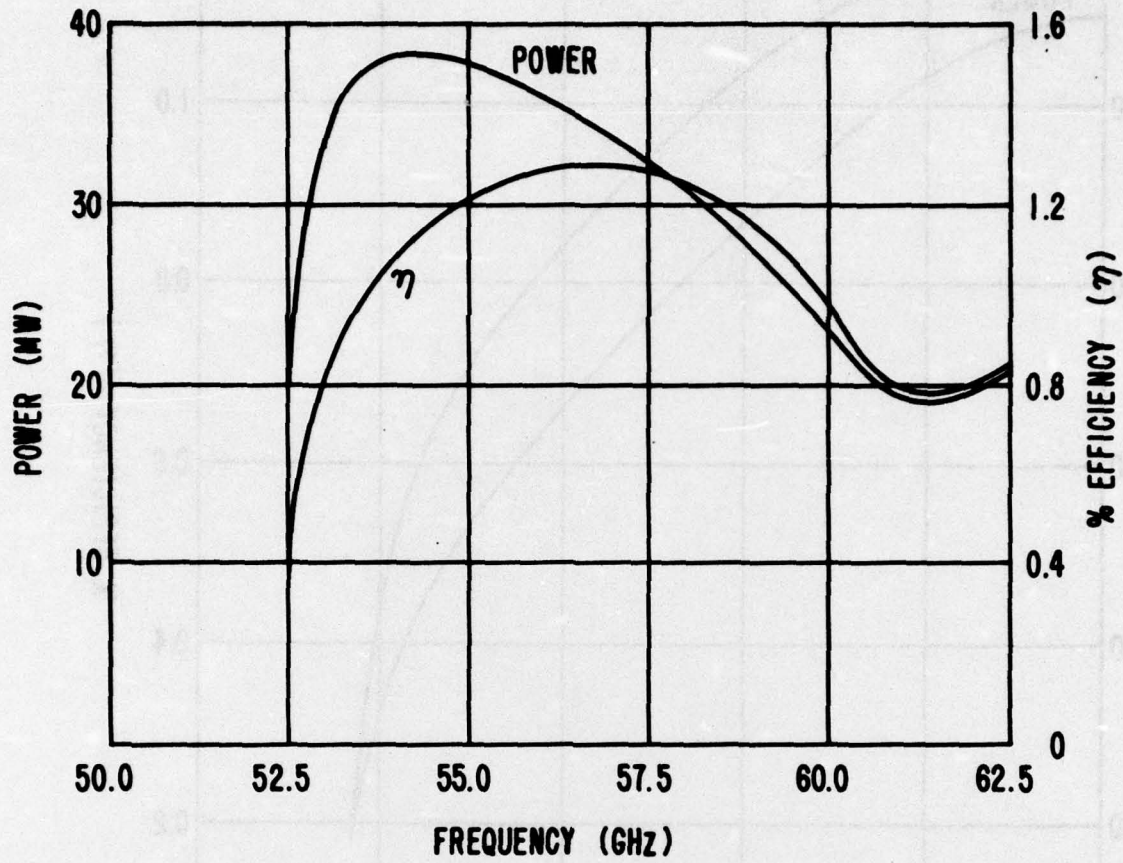

FIGURE 5. GUNN OSCILLATOR CHARACTERISTICS
(VARIAN MODEL WF101A DIODE)

7. DISCRIMINATOR The linear discriminator has a 60 MHz center frequency and 40 MHz peak to peak bandwidth. The linear (better than 3% over the linear range) bandwidth is 32 MHz and video baseband is 10 MHz, which allows only a 10 Mb data rate (max) without distortion. Limiting starts with a signal of -30 dBm or better. Hard limiting at 0 dBm input. A wideband low distortion video amplifier (AC coupled emitter follower) provides the main video output. There is a supplementary output of approximately 0.1v. main output voltage by direct coupling to the main output. This voltage is used to control the frequency of the LO to 60 MHz below the transmitter signal by controlling the DC bias current of the LO.

Future plans include the use of a discriminator with a wider video baseband to accommodate a 20 Mb/s data rate.

8. FM SYSTEM Frequency shifting is accomplished by varying the bias current (or modulating the DC input current of the IMPATT diode). It was found that a 1 ma increase in the bias current results in about a 10 MHz decrease in the frequency. For a system capability of 20 Mb data rate, 1.4 mA modulation of the bias current will give the needed 14 MHz shift at 60.0 GHz transmitter frequency.

The output of the IF amplifier is fed to the discriminator which provides the output data. The supplementary output (direct coupled with 1/10 the main output voltage) provides AFC by regulating the DC bias current. A block diagram of a 60 GHz FM communication system is shown by Figure 6.

MILLIMETER WAVE SYSTEM PERFORMANCE

Signal Frequency: 60 GHz

The use of short millimeter waves for communication between a command center or computer complex where distances are in the order of a kilometer or less warrants the use of the 60 GHz absorption band. The high attenuation of a signal in such a band provides a degree of intercept security not realized at frequencies that fall within the atmospheric windows. Adequate power is available and small antennas provide sufficient signal level. The parameters for a 60 GHz short range communication system are as follows:

	<u>Clear Weather</u>
Path length	1 km
Transmit power (65mw)	+18 dBm
Transmit Antenna Gain (6" dish)	+37 dB
Receive Antenna Gain (6" dish)	+37 dB
Free Space Loss	-128 dB

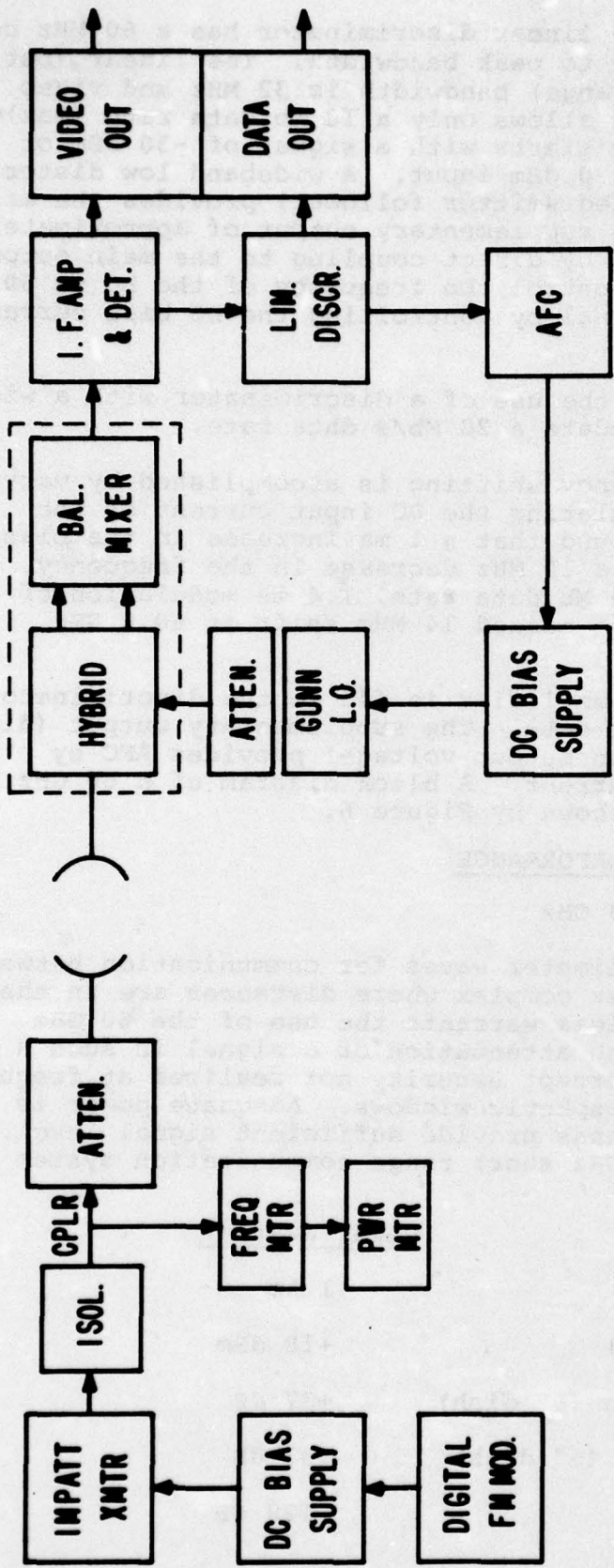

FIGURE 6. DIGITAL FM SIMPLEX COMMUNICATION SYSTEM

Clear Weather

Terminal loss	2dB
Oxygen and Water vapor loss	15 dB
Rain loss	0 dB
Received signal power	-53.0 dBm
Carrier to Noise ratio for threshold	13 dB
Receiver noise figure	13 dB (SSB)
Receiver bandwidth	20 MHz
Receiver threshold power	-75.0 dBm
Signal Margin	22.0 dB
Signal-to-Noise ratio	39.5 db for $\beta = 4.3$
Transmission Reliability	99.9999%

Reference to Figure 7⁷ indicates that a signal margin of 12.6 dB over a 1 km path will allow for a rain intensity of about 75 mm/hr before the available margin has been expended. Reference to Figure 8 shows that for this rain rate a transmission reliability in the order of 99.9% can be expected for the Washington, DC area where rain of this intensity occurs slightly under three hours during the year. In Freetown (sierra Leone) Africa, this margin would provide for a reliability of approximately 99.80%.

It is of interest for intercept purposes to determine the maximum distance at which a 60 GHz signal can be detected under clear weather conditions. Calculations indicate this distance to be 2.15 kilometers. At this distance, the received signal level is equal to the noise level of the receiver.

Should it be desired to extend the range of the system to 2 km with the same clear weather transmission reliability, additional gain would be required in the system. This may be accomplished by increasing the transmitter power to 200 mw and using 12 inch diameter parabolic antennas at both ends of the link. If the intercept aspects of the link are not an essential criteria, then by shifting the frequency of the system to 70 GHz, which is just outside of the atmospheric absorption band, transmission over a 2 km path can be provided with the same clear weather reliability (99.99%) with a transmitter power of 20 milliwatts and a 6 inch antenna-dish.

7. CADPL Engineering Memorandum, May '73, "60 GHz Communication System" L. E. Moore, DH Shedd.

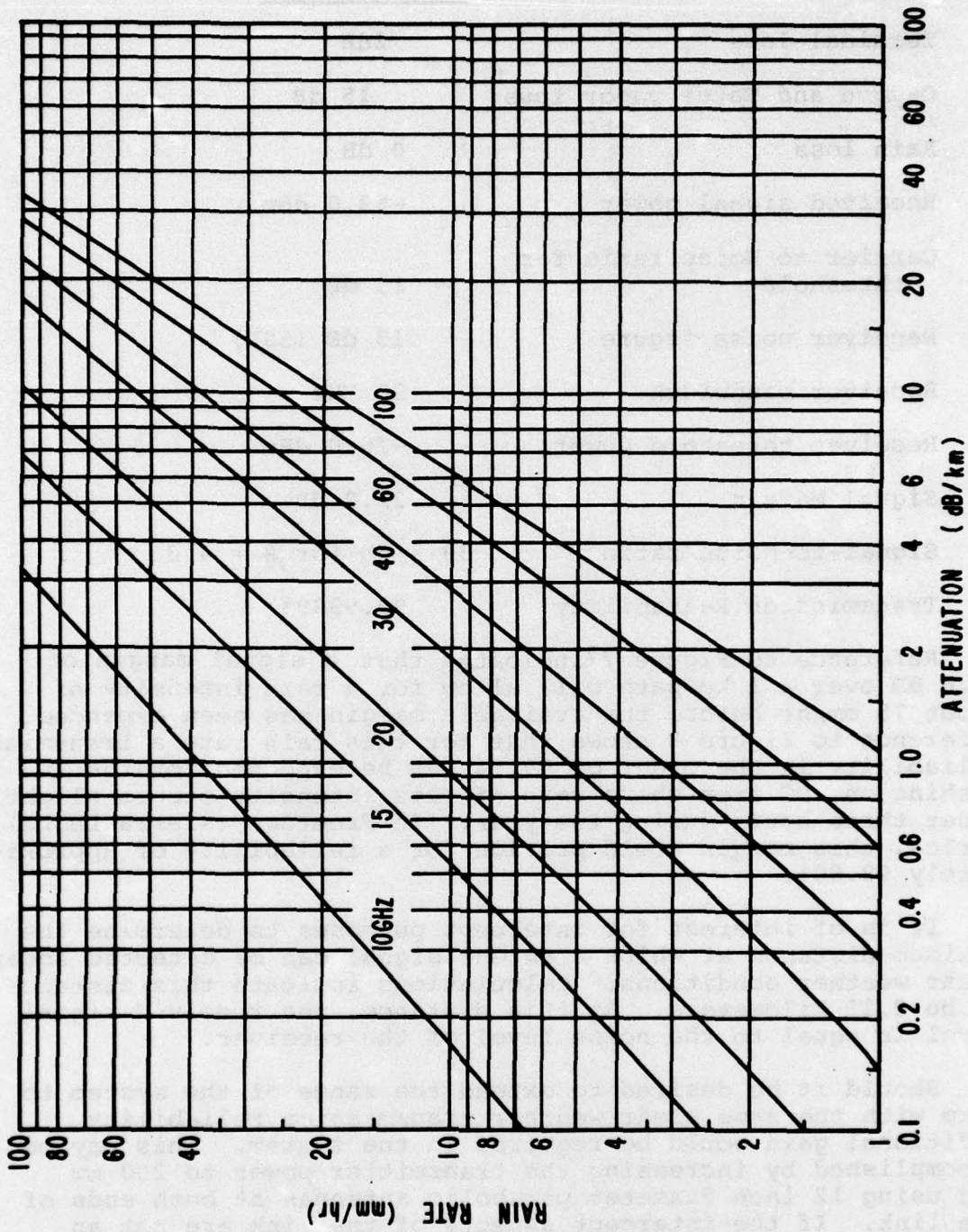

FIGURE 7. RAIN ATTENUATION

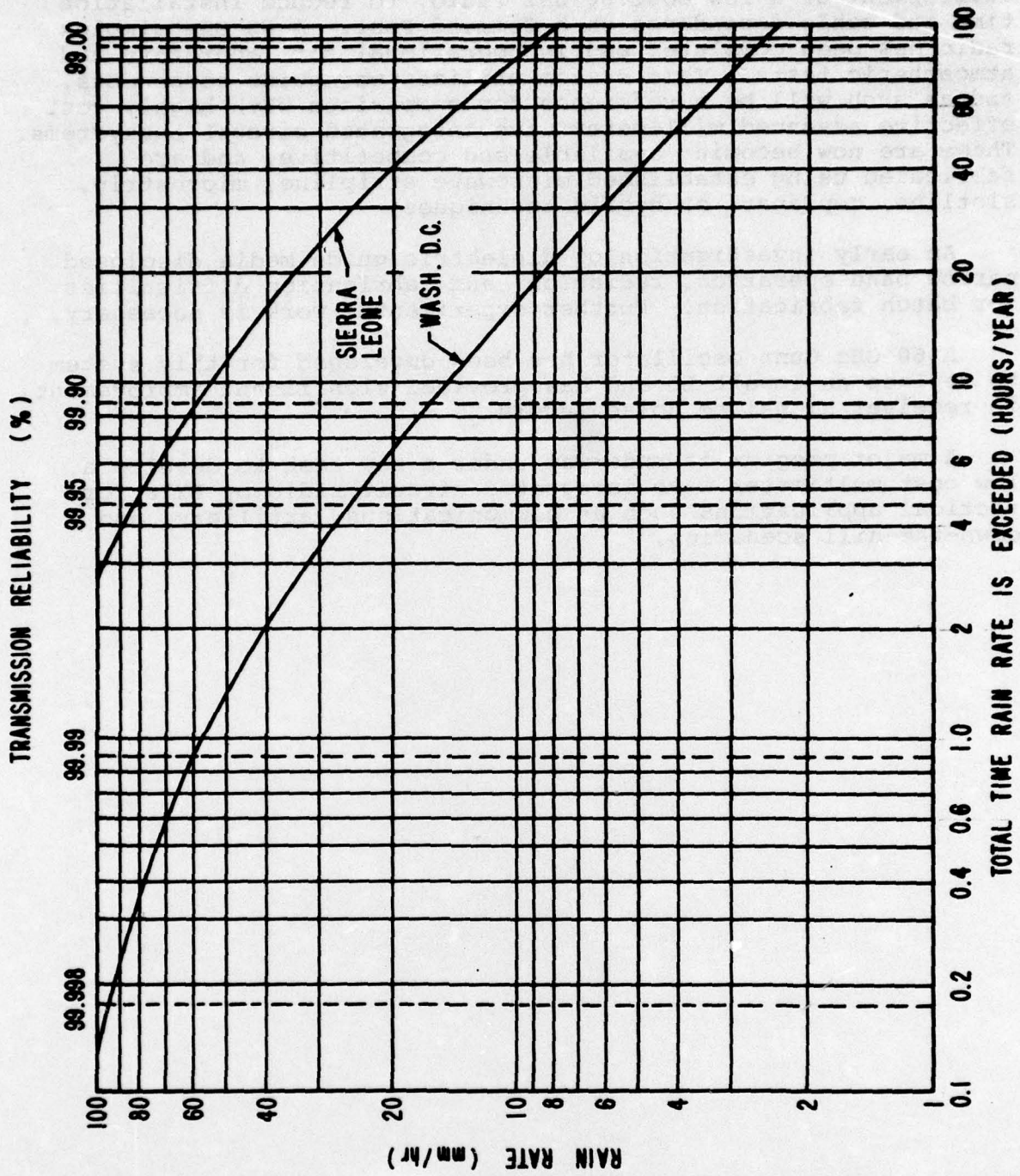

FIGURE 8. RELIABILITY

SUMMARY AND CONCLUSIONS The goal of this program is the development of a low cost 60 GHz radio, to reduce installation time and cable dependence on a Command Post. A 60 GHz simplex radio has been completed and is operational for laboratory and atmospheric tests. This system utilizes waveguide components, and as such will be a reference for comparison with highly cost effective advanced millimeter wave integrated circuit subsystems. These are now becoming available and competitive, and are fabricated using established microwave stripline, microstrip, slotline, coplanar, or hybrid techniques.

An early investigation of dielectric guide media disclosed narrow band operation, radiation, and fabrication difficulties for batch fabrication. Further experimental work is necessary.

A 60 GHz Gunn oscillator has been developed for this system to replace an Impatt LO and has provided significant improvement in receiver signal to noise levels.

A major program is underway under a new task to develop a low cost multimeter wave integrated circuit radio by FY78 for tactical applications such as communications, artillery, and down-the-hill scenarios.