

AG A033118

COPY NO. 24

TECHNICAL REPORT 4955

RESPONSE OF PRIMARY EXPLOSIVES TO
GASEOUS DISCHARGES IN AN IMPROVED
APPROACHING-ELECTRODE
ELECTROSTATIC SENSITIVITY APPARATUS

MAURICE KIRSHENBAUM

OCTOBER 1976



APPROVED FOR PUBLIC RELEASE; DISTRIBUTION UNLIMITED

PICATINNY ARSENAL
SCIENTIFIC AND TECHNICAL INFORMATION BRANCH

PICATINNY ARSENAL
DOVER, NEW JERSEY

Archive 87:4955

The findings in this report are not to be construed as an official Department of the Army position.

DISPOSITION

Destroy this report when no longer needed. Do not return to the originator.

UNCLASSIFIED

SECURITY CLASSIFICATION OF THIS PAGE (When Data Entered)

REPORT DOCUMENTATION PAGE		READ INSTRUCTIONS BEFORE COMPLETING FORM
1. REPORT NUMBER Technical Report 4955	2. GOVT ACCESSION NO.	3. RECIPIENT'S CATALOG NUMBER
4. TITLE (and Subtitle) Response of Primary Explosives to Gaseous Discharges in an Improved Approaching-Electrode Electrostatic Sensitivity Apparatus	5. TYPE OF REPORT & PERIOD COVERED	
	6. PERFORMING ORG. REPORT NUMBER	
7. AUTHOR(s) Maurice S. Kirshenbaum	8. CONTRACT OR GRANT NUMBER(s)	
9. PERFORMING ORGANIZATION NAME AND ADDRESS Feltman Research Laboratory Picatinny Arsenal, Dover, NJ	10. PROGRAM ELEMENT, PROJECT, TASK AREA & WORK UNIT NUMBERS DA Project 1W662617AH79 AMCMS Code 661617.11.H7905	
11. CONTROLLING OFFICE NAME AND ADDRESS	12. REPORT DATE October 1976	
	13. NUMBER OF PAGES 61	
14. MONITORING AGENCY NAME & ADDRESS (if different from Controlling Office)	15. SECURITY CLASS. (of this report) Unclassified	
	15a. DECLASSIFICATION/DOWNGRADING SCHEDULE	
16. DISTRIBUTION STATEMENT (of this Report) Approved for public release; distribution unlimited.		
17. DISTRIBUTION STATEMENT (of the abstract entered in Block 20, if different from Report)		
18. SUPPLEMENTARY NOTES		
19. KEY WORDS (Continue on reverse side if necessary and identify by block number) Electrostatic sensitivity apparatus RD1333 lead azide Approaching electrode apparatus Tetracene Electrostatic sensitivity of primary explosives Spark discharge Basic lead styphnate Arc discharge		
20. ABSTRACT (Continue on reverse side if necessary and identify by block number) <p>This report describes an improved, approaching-needle electrostatic sensitivity apparatus as well as the instrumentation used for measuring time-dependent gaseous discharge characteristics. It is shown that the addition of resistances in series with the gap changes the nature of the discharge as found previously for the fixed-gap apparatus. The energy delivered from the storage capacitor to the gap is 3-6% for an arc discharge and 15-25% for a spark discharge.</p>		

UNCLASSIFIED

SECURITY CLASSIFICATION OF THIS PAGE(When Data Entered)

19. Key Words (continued)

Electrical discharge characteristics
Gaseous discharge
Energy dissipated in the gap

20. Abstract (continued)

The initiation of basic lead styphnate, RD1333 lead azide, and tetracene by gaseous discharge is a strong function of the energy delivery rate. The threshold initiation energy values were considerably less in the spark mode (long duration discharge) than in the oscillatory or arc modes (short duration discharges). The ranking of the sensitivity of these three primary explosives did not vary with the mode of discharge as found previously for the fixed-gap, parallel-plate apparatus.

To meet the need for a single, standardized electrostatic sensitivity apparatus and test method able to distinguish between primary, booster or main charge explosives and to rank the sensitivity of explosives, the approaching needle apparatus used in this study, with slight modifications, is proposed to the Joint Service Committee for adoption as a Tri-Service standard.

UNCLASSIFIED

SECURITY CLASSIFICATION OF THIS PAGE(When Data Entered)

The citation in this report of the names of commercial firms or commercially available products or services does not constitute official endorsement or approval of such commercial firms, products, or services by the U.S. Government.

ACKNOWLEDGMENTS

The author wishes to thank Mr. E. Homentowski for his helpful advice in the design of the electrical circuits and Mr. K. Edwards for his help in designing and fabricating the approaching-electrode apparatus.

TABLE OF CONTENTS

	<u>Page No.</u>
Introduction	1
Experimental	2
Apparatus	2
Materials	2
Procedure	2
Point-to-Plane Geometry	2
Plane-to-Plane Geometry	3
Minimum Initiation Energy Determination	4
Results	4
Gaseous Discharge Characteristics	4
Reproducibility	10
Efficiency of Energy Dissipated in the Gap	10
Initiation Energy Values	14
Effect of Humidity and Electrode Configuration on Initiation Probability	17
Discussion	19
Effect of Energy Delivery Rate on Initiation Probability	19
Improved Apparatus for Assessing Electrostatic Hazards	19
Conclusions	23
References	24

Appendixes

A	Description of Apparatus	27
B	Proposed Electrostatic Sensitivity Test Procedure	41

	Distribution List	51
--	-------------------	----

Tables

1	Reproducibility of determinations using RD1333 lead azide (Minimum fire point)	11
2	Initiation energy values of three primary explosives	15
3	Effect of spark starting position on results for RD1333 lead azide ($R = 100 \text{ k}\Omega$ $C = 1176 \text{ pF}$)	18
4	Energy characteristics of apparatuses in current use	22

Figures

1	Typical current characteristics	6
2	Dependence of duration of discharge on series resistance and charging capacitance	8
3	Representative current - voltage waveforms	12
4	Charging circuit	31
5	Approaching-electrode assembly	32
6	Needle-plane electrode assembly	33
7	Plane-to-plane electrode assembly	34

8	Needle assembly	35
9	Schematic showing operation of approaching assembly	36
10	Proposed electrical circuit	39

INTRODUCTION

Electrostatic sensitivity tests are used to assess the electrostatic hazards associated with the processing and handling of explosives. There is, however, no standard electrostatic test, because those in current use were independently designed and fabricated by government or private laboratories for internal purposes. Although, in principle, the tests are similar, the parameters of the equipment are different. Consequently, widely varying minimum energy values can be obtained for the same explosive. It is also possible for the ranking of the sensitivities of explosives to vary with the same apparatus when the test parameters or the rate of energy delivery are changed (Ref 1).

Many of the differences have been explained (Ref 1-3). It has been shown that the electrical circuit, the electrode configuration, the cathode properties, and the nature of the explosive all play important roles. In a previous study (Ref 1,2), the gaseous discharge characteristics of a fixed-gap apparatus having parallel-plate electrodes were determined. It was shown that the electric discharge through a gas can exist as an arc or a spark. It was also shown that the initiation probability and the ranking of the sensitivities of primary explosives vary with the rate of energy delivery.

In the present study, the approaching-electrode method was evaluated. The following objectives were adopted:

1. To develop a versatile, approaching-electrode apparatus and test procedure which is safe, convenient, and capable of yielding meaningful and reproducible results.
2. To determine the current and voltage characteristics of the gaseous discharge for an arc, a spark, and an oscillatory discharge with the approaching-electrode apparatus.
3. To determine the extent to which the mode of discharge affects the initiation probability of a primary explosive and its relative sensitivity.
4. To determine the effect of humidity, gap length, and electrode configuration on the initiation probability of primary explosives.

EXPERIMENTAL

Apparatus

The approaching-electrode apparatus consisted of a variable high voltage power supply, a capacitor-charging circuit, an electrostatic voltmeter, an approaching-electrode assembly (gap and electrode configuration could be varied), a high-speed oscilloscope, and an electrometer. A detailed description of the apparatus is contained in Appendix A.

Materials

RD1333 lead azide: Lot Number OMC 2-2

Basic lead styphnate: Lot Number OMC 68-14

Tetracene: Lot Number OMC 67-18

The explosive powders were stored in desiccators containing anhydrous CaSO_4 for at least 24 hours prior to test. The firing chamber was maintained at $35 \pm 3\%$ relative humidity by continuously passing dry air through the chamber.

Procedure

Two electrode systems were used to measure the electrostatic sensitivity of the explosives: the point-to-plane and plane-to-plane geometries. The procedures were as follows.

Point-to-Plane Geometry

The selected capacitance and resistance units were connected in the firing circuit (Fig 4). The base electrode was adjusted so that a 0.18 mm (0.007") preset gap would be obtained when the approaching electrode was depressed rapidly by the spring (Fig 5). The explosive powder, varying in weight from five to ten milligrams (depending on the bulk density of the explosive), was placed on the steel sample holder in a pile at least 1 mm thick (Fig 6). The sample holder was then placed on the base electrode with the powder directly under the needle. The spring-loaded approaching electrode was then cocked and the power supply was turned on (Fig 4). By activating the reset switch, the storage capacitor was charged to the desired voltage, which was read on the electrostatic

voltmeter. When the approaching electrode spring was released, the needle rapidly moved downward to the preset gap distance at an average speed of about 51 cm (20 inches) per second, which is equivalent to 0.05 mm/100 μ sec, and immediately rose to its initial position. The threshold voltage for gap breakdown determined the distance between the needle and the lower electrode when the discharge first occurred. The discharge occurred through the interstices of the powder. Initiation or non-initiation of the explosive was observed.

One to three trials were carried out on each sample of explosive on the same sample holder, the number of trials depending on whether the sample initiated. The same material was reused in order to increase the number of tests conducted in a day. However, a new portion of the sample was exposed to each discharge by moving the holder about on the base electrode. After each explosive initiation, the needle was replaced and the sample holder cleaned first, with No. 400 and then with No. 600 emery cloth, and finally, polished with crocus cloth. The needles used were Duotone, steel, phonograph needles, 1.5 mm diameter by 15.2 mm long, with a 26° cone angle and a 0.05 mm radius tip. In some of the trials, with no series resistance, a confining nylon washer (3.2 mm thick by 19 mm o.d. by 8 mm i.d.) was attached to the sample holder in order to reduce dispersal of explosive caused by the gaseous discharge.

Plane-to-Plane Geometry

A procedure similar to the one used for the needle-plane system was used for the plane-to-plane geometry (Fig 7). An explosive sample, varying in weight from three to eight milligrams (depending on the bulk density of the explosive), was placed in the sample holder consisting of a 4.8 mm diameter hole in a disc of a 0.19 mm thick polyvinyl chloride electrical tape on a 19 mm diameter flat steel disc serving as the sample holder. After being tapped gently so that the powder completely covered the bottom and distributed itself evenly across the hole, the sample holder was placed on the base electrode. The base electrode was so adjusted that when the movable electrode was completely depressed, the preset gap distance would be the thickness of the electrical tape, 0.19 mm, and the upper electrode would be directly above the explosive powder. After each trial, a fresh sample was used, whether or not initiation had occurred. After each initiation, the steel pin was replaced and the sample holder cleaned, first with No. 400, then with No. 600 emery cloth, and finally polished with crocus cloth. The pin electrode was 0.48 mm in diameter and 14.9 mm in length, with flat ends having a 0.25 mm radius rounded edge.

Minimum Initiation Energy Determination

Sensitivity measurements were carried out for each explosive for the oscillatory, the arc, and the spark discharge. A 2 kilohm ($2\text{ k}\Omega$) or a $100\text{ k}\Omega$ resistor was added in series with the gap to produce the arc or the spark discharge, respectively. No resistance was added for the oscillatory discharge. The individual capacitors used had values of 54, 115, 276, 636, 1176, 2030, 3400, 4950, and 6980 pF. The capacitors and resistors selected for voltage-capacitance values were placed in the firing circuit. The starting point was usually the largest capacitor, unless a lower value, based on experience, was known to be capable of initiation. The energy of the discharge was reduced in increments by decreasing the initial voltage across the capacitance until no initiation was obtained in 25 consecutive trials. The voltage was reduced from 7500 V in 500 V steps until the voltage was 2000 V. Then, the voltage was decreased in 150 V steps. The starting voltage was usually 7500 V, unless a lower value, based on experience, was known to be capable of initiation. The resistance and/or capacitance was then changed and the procedure repeated. This was continued until minimum values were obtained for all the capacitances and resistances.

The degree of explosive powder consumption varied, from low levels, evidenced by the emission of a very small amount of smoke (barely visible) or a slight burn mark on the steel sample holder, to complete burning or detonation. With fine powders it was difficult to tell whether ignition actually occurred, or whether the smoke observed was just finely divided particles of the explosive dispersed by the discharge. The criterion for ignition used in this study was that at least 50% of the explosive had to be consumed. However, the nature of the explosive reaction was noted in all cases.

RESULTS

Gaseous Discharge Characteristics

A series of experiments was carried out to characterize the gaseous discharges in air for the approaching-electrode apparatus as a function of the capacitance and resistance in the discharge circuit. These experiments showed that the characteristics were very similar to those observed for the fixed-gap, parallel-plate apparatus (Ref 1,2).

When a charged capacitor was discharged through the spark gap, several different modes of discharge occurred depending upon the value of the series resistance. With no series resistance in the discharge circuit, the current and voltage of the gaseous discharge varied in an oscillatory (underdamped) manner due to a $1.3 \mu\text{H}$ inductance inherent in the circuit. The current and voltage were slightly out of phase, with the voltage leading the current. Addition of resistance to the circuit damped out the discharge and resulted in an overall shortening of the discharge time. The discharge time reached a minimum when the added resistance resulted in a critically damped circuit. Further increases in resistance resulted in unidirectional (overdamped) discharges of longer duration. With large series resistances (hundreds of kilohms) the discharge was no longer continuous but took the form of bursts of sparks due to relaxation oscillations. Figure 1 shows the current waveforms for several values of series resistances when a 1176 pF capacitor charged to 3000 V was discharged to ground through the spark discharge circuit containing a 0.18 mm preset gap.

In addition to changing the character of the discharge, changing the series resistance also changed the duration of the discharge (Fig 2) and thus changed the energy delivery rate. The effective duration of the oscillatory (zero resistance) discharge was in the 0.1 to $1 \mu\text{sec}$ range; the peak current was in the 30 to 100 A range. With the use of a $2 \text{ k}\Omega$ resistor the effective arc discharge time was 1 to $20 \mu\text{sec}$ in duration and the peak current was in the 2 to 7 A range. The effective duration of the spark discharge was hundreds of microseconds. Its peak current was only a few milliamperes.

A third effect of adding series resistance was to change the fraction of the energy stored in the capacitor that was dissipated in the spark gap. This effect is considered in detail in another section of the report (Efficiency of Energy Dissipated in the Gap).

The effect of increasing the capacitance in the circuit can be seen in Figure 2. An increase in the capacitance increased the duration of the discharge in addition to increasing the energy available to the spark.

Gaseous discharge was obtained only intermittently when the voltage was decreased below 2000 V with the 0.18 mm gap or below 4000 V with a 0.64 mm gap. Therefore, no tests were conducted at voltages below

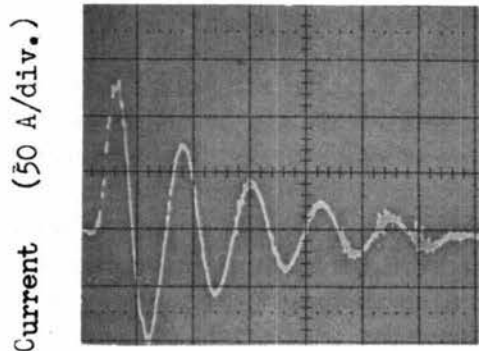

Discharge Time
(200 nsec/div.)

a) $R = 0$ ohms

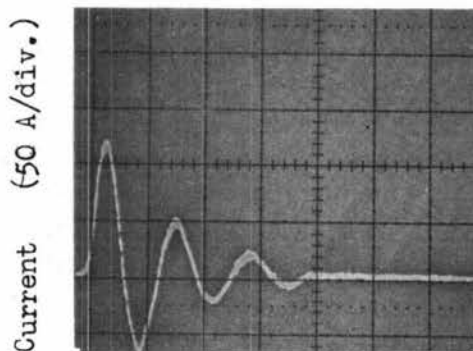

Discharge Time
(200 nsec/div.)

b) $R = 3.3$ ohms

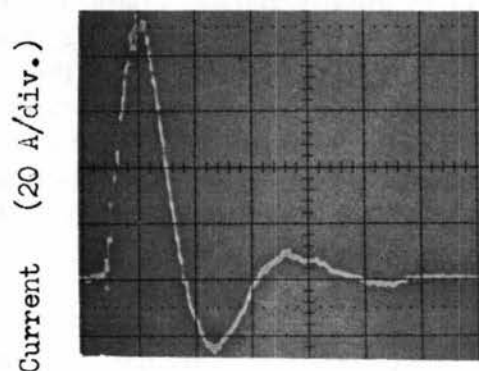

Discharge Time
(100 nsec/div.)

c) $R = 20$ ohms

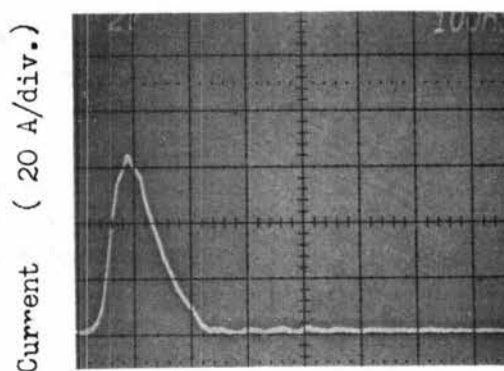

Discharge Time
(100 nsec/div.)

d) $R = 56$ ohms

Fig 1 Typical current characteristics

(1176 pF capacitor charged
to 3,000 V)

Current (10 A/div.)

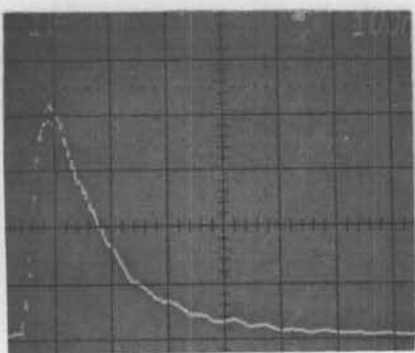

Discharge Time
(100 nsec/div.)
e) $R = 100$ ohms

Current (0.5 A/div.)

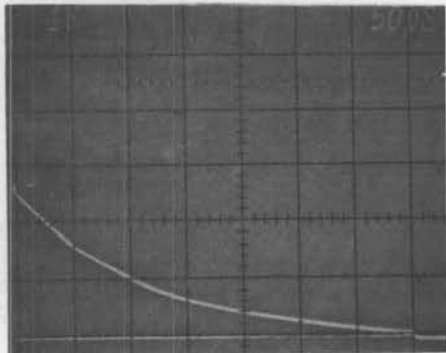

Discharge Time
(1 μ sec/div.)
f) $R = 2$ kilohms

Current (10 mA/div.)

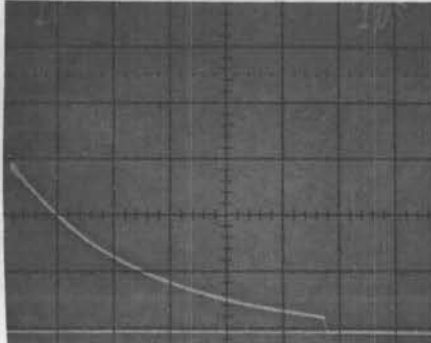

Discharge Time
(50 μ sec/div.)
g) $R = 100$ kilohms

Current (1 mA/div.)

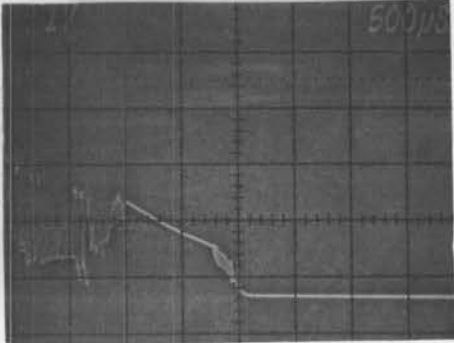

Discharge Time
(500 μ sec/div.)
h) $R = 1$ megohm

Fig 1 (continued)

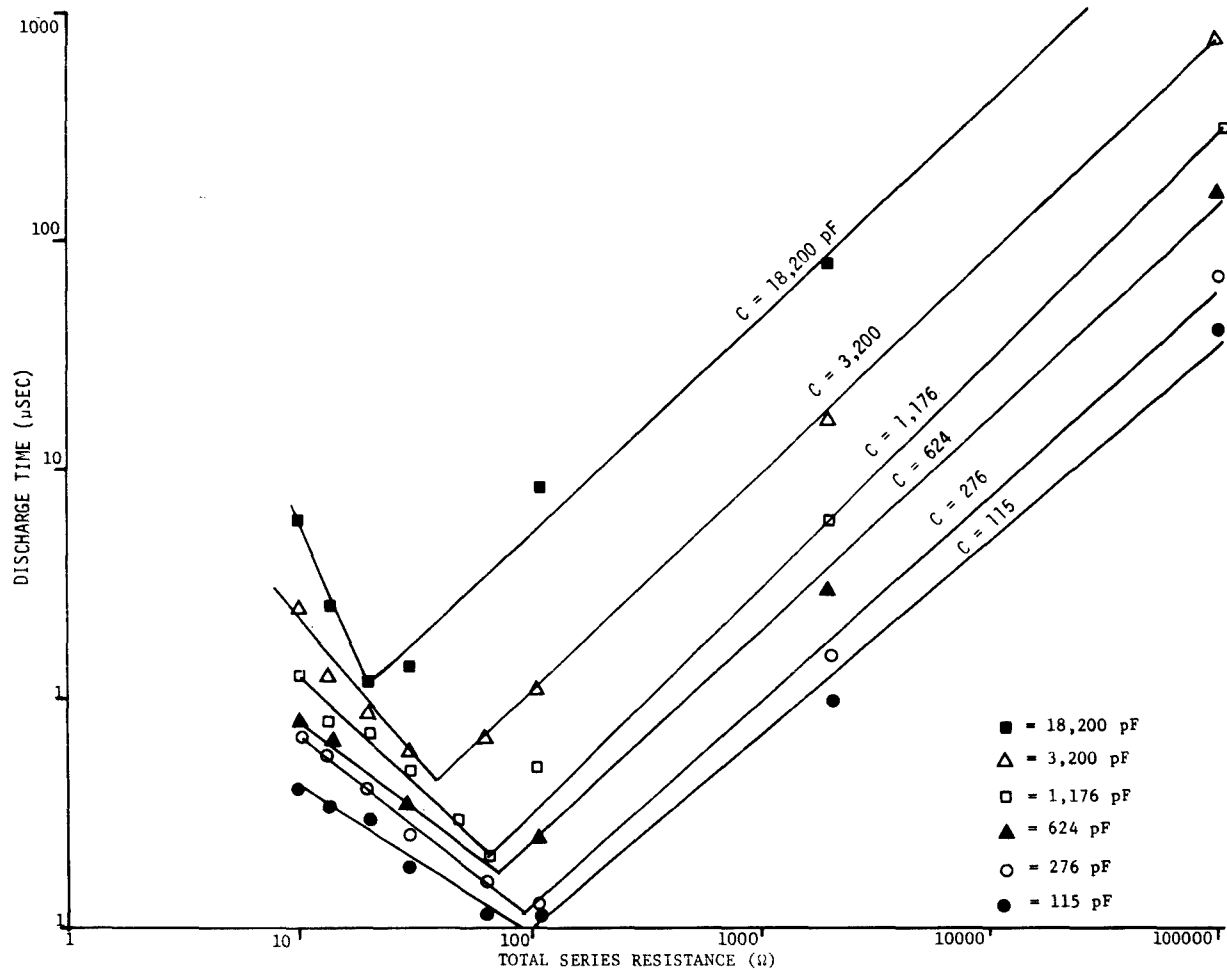

Fig 2 Dependence of duration of discharge on series resistance and charging capacitance (Series resistance includes the 7.5 ohm resistance of the gap. Minimum discharge time occurred when the discharge circuit became critically damped.)

these values. The shape of the electrode plays an important role in gaseous discharge. Lower threshold voltages for constant-gap-length breakdown were noted for gaseous discharge in the plane-plane configuration than in the needle-plane electrode geometry. The addition of powder to the gap decreased the threshold voltage for breakdown with the needle-plane electrodes, but increased it for the plane-plane electrode configuration. A possible explanation for this phenomenon is photon feedback which was discussed in detail in Reference 2.

The shape of the approaching electrode also affects corona discharge. With the charged needle electrode in the raised position, 22 mm (7/8 inch) above the base electrode, it was observed that corona discharge started when the charging voltage attained 7500 V. The charge flowed through the gap at a rate of 1 microcoulomb/sec. With the charged, pin-electrode, however, no corona discharge was observed for voltages up to 8800 V, the highest voltage used.

For a better understanding of electrostatic sensitivity data, it is important to recognize that unidirectional discharge can occur as arcs or sparks (glow discharge). Both modes may occur in a single discharge, depending primarily on the resistance in the discharge circuit and to a lesser extent on the initial voltage. An arc is a post-breakdown discharge in which thermionic emission from the cathode is responsible for sustaining the discharge. The most characteristic features of an arc are the low post-breakdown voltage drop across the gap, which is usually of the order of tens of volts (30-125 V), and the high current flow, larger than 0.3 - 0.5 A. An arc may be formed for series resistances as large as 10-20 kilohms, and for gaps as large as 1.3 mm (0.050 in.). A spark discharge, on the other hand, is a post-breakdown regime in which the discharge is maintained by secondary emission of electrons from the cathode by ion-bombardment. The voltage drop across the spark is typically 300-400 V and the current is in the milliampere range. Representative current and voltage waveforms for an arc and a spark are shown in Figure 3 for resistances of 2, 10, and 100 kilohms. Figure 3A represents an arc discharge. The voltage across the gap, which was initially sufficiently high to break down the gap (greater than 1400 V), rapidly decreased to the low post-breakdown voltage of approximately 35-125 V (seen as level a in Figure 3A) and remained at this low voltage until the discharge ceased. The voltage across the gap then increased to the open circuit voltage due to the residual charge on the storage capacitor (level b), since there was no longer a voltage drop across the series resistor. The current (dashed line) decreased as the storage capacitor

discharged in a conventional capacitor discharge pattern from several amperes to below a minimum sustaining value (point c), at which time the discharge ceased.

With the 100-kilohm resistor (Fig 3C), a spark discharge was obtained. The parameters are the same as for Figure 3A except for the higher series resistor. The behavior is similar to that of the arc (Fig 3A) except that the post-breakdown voltage was higher, approximately 300-450 V, and the peak current was lower, about 30 milliamperes. For an intermediate resistance (10-kilohms) (Fig 3B), the waveforms show that there was a transition during the discharge from an arc to a spark. The gap voltage during the discharge jumped abruptly from 100 V (arc) to 350 V (spark) with a change in the slope of the current waveform. In the transition range the nature of the discharge can be different for repetitive tests. No changes were observed in the current and voltage waveforms when aluminum, brass, or stainless steel electrodes were substituted for the steel base (negative) electrode.

Reproducibility

Three series of tests were carried out with RD1333 lead azide to determine the reproducibility of the approaching-electrode apparatus. Two of the tests were for the needle-plane electrodes, and one was for the plane-plane electrodes. The results, summarized in Table 1, show excellent reproducibility. The reproducibility tests were conducted for the minimum firing point. The first and third tests were for an oscillatory discharge ($C = 1176 \text{ pF}$, $R = 0$), while the second test was for a spark ($C = 624 \text{ pF}$, $R = 100 \text{ k}\Omega$). Twenty-five trials were carried out at each test level and this is probably the source of the excellent statistical reproducibility of the tests. In addition, the humidity was kept constant and a minimum sample height of 0.18 mm was maintained to insure that the discharge occurred entirely within the sample. The effects of humidity and gap length are discussed in another section of the report.

Efficiency of Energy Dissipated in the Gap

The fraction of the total stored energy that was dissipated in the gap varied with the circuit parameters. There was a marked difference (400-500%) in the post-breakdown voltage drop across the gap of the arc and of the spark, whereas the differential of the charge (total current) flowing in an arc vs a spark was only about 10%.

Table 1

Reproducibility of determinations using RD1333 lead azide
(Minimum fire point)

Needle-plane	Two experiments, two months apart (oscillatory discharge; series resistance = 0; storage capacitance = 1176 pF) First experiment: 45,000 ergs ($45,000 \times 10^{-7}$ J) Second experiment: 45,000 ergs
Needle-plane	Four experiments, two weeks between the first and second, one day between second and third, and eight months between the third and fourth (Spark discharge: series resistance = 100 k Ω ; storage capacitance = 624 pF) First experiment: 7,300 ergs* Second experiment: 5,800 ergs Third experiment: 5,800 ergs Fourth experiment: 5,800 ergs
Plane-plane	Two experiments, three weeks apart (oscillatory discharge; series resistance = 0; storage capacitance = 1176 pF) First experiment: 45,000 ergs Second experiment: 45,000 ergs

NOTE: Twenty-five trials were carried out at each test level.

*The minimum energy determined in the first experiment was one step (500 V) higher than that of the other three experiments.

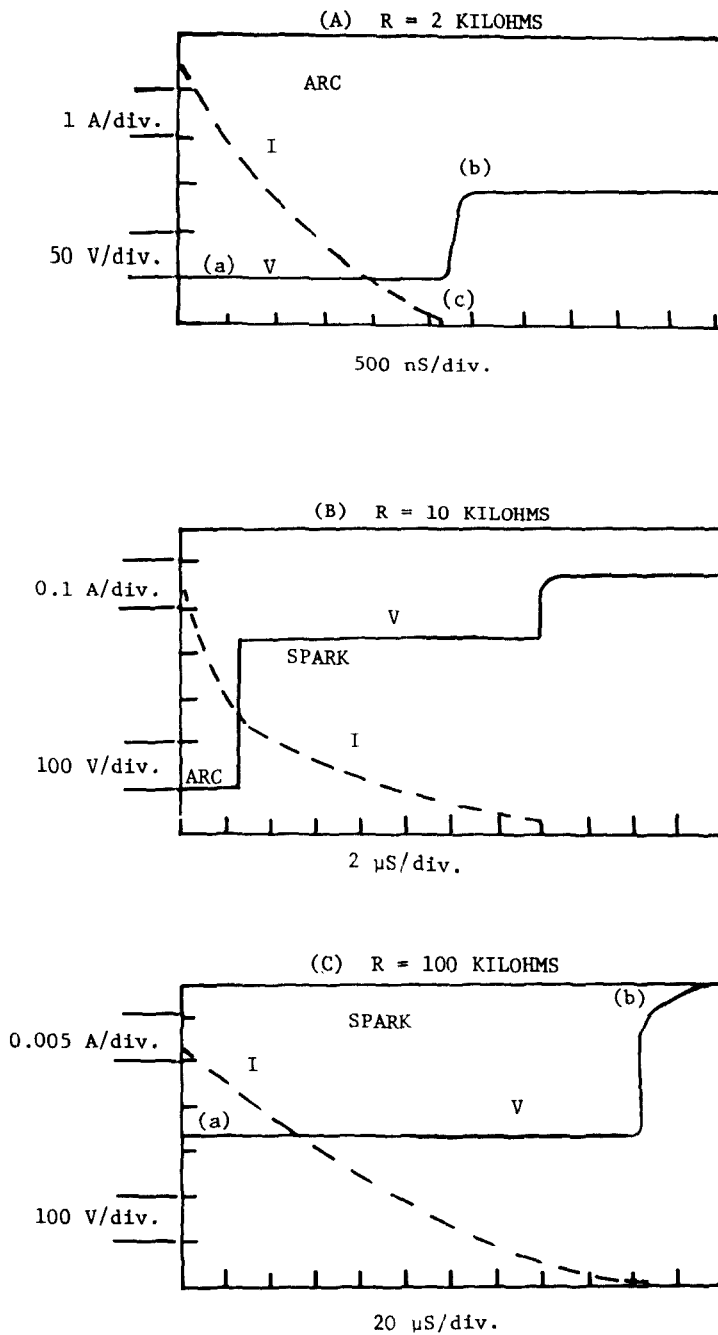

Dashed Line: Current vs. Time

Solid Line: Voltage vs. Time

Fig 3 Representative current - voltage waveforms

The energy dissipated in the gap may be written,

$$E_{\text{gap}} = \int V_g(t) I_g(t) dt \quad (1)$$

where

$V_g(t)$ = instantaneous gap voltage

$I_g(t)$ = instantaneous gap current

The voltage waveforms (Fig 3) show that the voltage drop for either an arc or a spark is approximately constant. Thus, Equation 1 may be rewritten,

$$\begin{aligned} E_{\text{gap}} &= V_g \int I_g dt \\ &= V_g Q_g \end{aligned} \quad (2)$$

where Q_g is the total charge passing through the gap. The total charge in microcoulombs (μC) was determined by measuring the final voltage, V , across a one microfarad capacitor, C , in series with the gap,

$$Q_g = CV \quad (3)$$

The total energy available in the storage capacitor, E_{cap} , is,

$$E_{\text{cap}} = 1/2 C_0 V_0^2 \quad (4)$$

where

C_0 = capacitance of the storage capacitor

V_0 = voltage to which the capacitor is initially charged

The efficiency is the fraction of the total energy in the storage capacitor which is dissipated in the gap containing the sample; thus,

$$\frac{E_{\text{gap}}}{E_{\text{cap}}} = \frac{2Q_g V_g}{C_0 V_0^2} \quad (5)$$

For an arc discharge (series resistance = 2 k Ω), the efficiency decreased from 6 to 3% as the storage capacitance was decreased from 2000 to 276 pF. Keeping the storage capacitance constant, the efficiency remained practically constant as the charging voltage was decreased from 4500 to 2000 V. For a spark discharge (series resistance = 100 k Ω), on the other hand, the efficiency remained practically constant at each voltage level as the storage capacitance was decreased from 2000 to 624 pF. For each capacitance, however, the efficiency decreased from 22 to 16% as the charging voltage was increased from 2000 to 45000 V. For an oscillatory discharge (no added series resistance), it was estimated that 90% of the stored energy was dissipated in the gap.

Initiation Energy Values

The minimum initiation energy values for basic lead styphnate, RD1333 lead azide and tetracene were determined for an oscillatory, an arc, and a spark discharge by means of both the approaching-needle and the approaching-plane electrodes. The results are shown in Table 2. The 50% initiation energy values for a spark discharge (needle) are also listed in Table 2. Lead styphnate is the most sensitive explosive and tetracene is the least in this test. The minimum energy required to initiate lead styphnate was only about one-twentieth or one-hundredth of that needed for lead azide or tetracene, respectively, under the particular test conditions. The 50% values indicated a similar trend; one-third or one-ninth for each of the two explosives, respectively. The minimum values obtained for lead styphnate may also have been limited by the lowest capacitance of the apparatus (54 pF) and the threshold voltage for gap breakdown. It is noted that lower initiation energy values were obtained in the spark mode than in the oscillatory or arc modes.

In a previous study using a fixed-gap, parallel-plate apparatus (Ref 1), it was shown that the ranking of the initiation of three primary explosives varies for the three different discharge modes. However, no variation in initiation ranking was observed as function of discharge mode using the approaching-needle apparatus. The data (Table 2) show that the fixed-gap, parallel-plate apparatus yielded lower initiation energy values for RD1333 lead azide and tetracene but higher values for basic lead styphnate than with the approaching-electrode apparatus. Two opposing trends can be used to propose an explanation of the foregoing results. The initiation energy values may have been lower for the fixed-gap, parallel-plate

Table 2

Initiation energy values of three primary explosives

<u>Discharge</u>	<u>Minimum Energy (10^{-7} J)</u>								
	<u>Basic Lead Styphnate</u>			<u>RD 1333 Lead Azide</u>			<u>Tetracene</u>		
	<u>AN</u>	<u>APP</u>	<u>FGPP</u>	<u>AN</u>	<u>APP</u>	<u>FGPP</u>	<u>AN</u>	<u>APP</u>	<u>FGPP</u>
Oscillatory	< 2,000	< 830	4,400	47,000	47,000	3,000	280,000	56,000	18,500
Arc	70	< 30	1,100	20,000	19,000	1,700	53,000	26,000	4,000
Spark	200	< 150	900	4,700	4,500	1,400	20,000	4,500	1,300
	<u>50% Points (10^{-7} J)</u>								
Spark	6,700	-	2,600	27,000	-	5,500	62,000	-	> 9,600

NOTES: AN = approaching needle

APP = approaching (pin) plane-to-plane

FGPP = fixed-gap, parallel-plate

electrodes because that configuration confined the powder more than did the needle-plane geometry and permitted more efficient "coupling" between the discharge and the powder. Also, the higher lead styphnate values recorded with the fixed-gap apparatus may have been due to the fact that the minimum initiation energy was not actually reached with lead styphnate. The lowest initiation energy values attainable with the fixed-gap apparatus were limited by the threshold voltage needed to break down the gap to produce a discharge and the lowest capacitance of the apparatus, 250 pF. (The approaching-electrode apparatus had a minimum capacitance of 54 pF.) The threshold voltage for gap breakdown depends upon the electrode shapes and materials, the gaseous medium, the separation of the electrodes and, to a lesser degree, the external circuit parameters.

Although the initiation probabilities of the explosives were greater for a spark than an arc, much faster initiation times were observed for the arc discharges, approximately 1 μ sec compared to about 150 μ sec for a spark. The faster initiation times can, most likely, be attributed to the higher temperature of the arc.

To demonstrate that the apparatus can be used to distinguish between primary, booster, and main-charge explosives, a wide variety of explosives were tested at an energy of 0.02 J, which is the charge energy that an ungrounded person can accumulate (Ref 4,5); however (Ref 6), this is about five times the maximum energy that an ungrounded person could discharge. Those explosives which are ignited at the 0.02-J level are in the primary explosive category. Thus, basic lead styphnate, RD1333 lead azide, dextrinated lead azide and tetracene all ignited. But, as expected, tetryl, PETN, superfine PETN, RDX, HMX, TNT, and Composition B did not ignite. Considerably greater energy (0.1 J) is required to initiate a booster explosive such as PETN. There is no electrostatic distinction between booster and main-charge explosives. Thus, primary explosives are easily differentiated from booster and main-charge explosives.

Effect of Humidity and Electrode Configuration on Initiation Probability

Humidity

It was demonstrated that lower initiation-energy values are obtained with the approaching-needle apparatus for dry powders tested at $35 \pm 3\%$ relative humidity than for powders maintained and tested at $60 \pm 5\%$. For example, the 50% initiation value for dry RD1333 lead azide for a spark discharge increased from 28,000 to $40,000 \times 10^{-7}$ J for the higher humidity conditions.

Electrode Configuration

It was also found that similar 50% initiation values were obtained for a 0.18 and for a 0.63 mm preset gap if the spark occurred in the explosive powder. However, higher values of spark energies were obtained for both the 0.18 and 0.63 mm gaps if the spark started above (out of) the explosive powder instead of occurring entirely within the powder (Table 3). It appears, therefore, that a maximum preset gap length and a minimum sample height have to be specified to insure that the discharge occurs entirely within the sample. Otherwise a variable portion of the gap energy would be lost and higher minimum energy values would be recorded. With the approaching-plane apparatus, it is not possible for the discharge to occur entirely within the sample since the pin does not penetrate the powder.

It was observed during the study with the approaching-pin apparatus that the explosive powder was more readily initiated if the same powder was subjected to a second trial. For example, although no initiation occurred in lead azide in 25 trials with fresh samples each time at $47,000 \times 10^{-7}$ J (oscillatory discharge; $R = 0$, 1176 pF capacitor charged to 3000 V), the explosive usually detonated at $47,000 \times 10^{-7}$ J if the same sample was subjected to another trial. To determine whether the increased sensitivity of lead azide was due to the initial electric field exposure or the initial impact or compaction of the powder, another series of tests were conducted. In these tests, each lead azide sample was subjected to two trials. In the first trial, no voltage was applied to the approaching pin and the pin only flattened the powder. In the second trial, voltage was applied (the energy was kept at $47,000 \times 10^{-7}$ J) and the lead azide sample usually detonated. It was determined that lead azide would detonate at an energy as low as $21,000 \times 10^{-7}$ J (oscillatory discharge; $R = 0$, 1176 pF capacitor charged to 2,000 V), if the sample was first compacted with the movable electrode.

Table 3

Effect of spark starting position on results for RD1333 lead azide

(R = 100 kΩ, C = 1176 pF)

<u>Base electrode material</u>	<u>Preset gap (mm)</u>	<u>Spark starting position with respect to sample</u>	<u>Energy (J x 10⁻³)</u>
Steel	0.18	External	3.4
Steel	0.18	Within	2.8
Steel	0.63	External	3.6
Steel	0.63	Within	2.6
Stainless steel	0.18	External	4.2
Stainless steel	0.18	Within	3.3

DISCUSSION

Effect of Energy Delivery Rate on Initiation Probability

The experimental data show that the energy required in the gap to ignite the three primary explosives by gaseous discharge was a strong function of energy delivery rate. For example, the minimum initiation-energy values were considerably less in the spark mode than in the oscillatory or arc modes. In a previous study (Ref 1) using a fixed-gap, parallel-plate apparatus, which confined the powder and prevented it from blowing away, it was also shown that long duration discharges were more efficient in producing initiation than short duration discharges of equal energy and that the energy required for ignition was markedly dependent upon the energy delivery rate. Priede (Ref 7) demonstrated that when a 50 k Ω series resistance was added to the capacitive discharge circuit, the minimum ignition energy for a hydrogen-air mixture was reduced to half that determined for the circuit without the resistance. Boyle and Llewellyn (Ref 8) were able to ignite dust clouds of magnesium or aluminum with less energy by a factor of ten when a series resistance of 10 to 100 k Ω was placed in the discharge circuit.

The initiation probability of individual explosives depends on transfer of energy from an external stimulus to the explosive sample. It is possible that the lower initiation probability of oscillatory and of arc discharges (short duration discharges) is due to a combination of factors rather than to any single one. The energy delivery rate dependency, however, suggests a time-dependent process, in which a minimum discharge (heat source) is maintained long enough to give rise to a propagating self-supporting hot-spot in the explosive crystal.

Improved Apparatus for Assessing Electrostatic Hazards

There is a need for a single, standardized electrostatic sensitivity test apparatus and procedure for characterizing explosives. A well designed apparatus should be able to (1) distinguish between primary, booster, or main-charge explosives, and (2) rank the sensitivities of explosives. The apparatus should be simple, safe, and capable of yielding meaningful and reproducible results. The approaching-needle apparatus used in the present study meets the above requirements and is proposed for adoption as a standard test. A detailed operating procedure and a description of the apparatus are given in the Appendix. Adoption of the apparatus and procedure should yield a proper assessment of the electrostatic hazards associated with the processing and handling of explosives.

Many different electrostatic sensitivity test apparatuses have been used in an attempt to determine the relative sensitivity of explosives. Although modifications have been made to reduce their shortcomings, the tests in current use are still crude. In particular, of the many variables that need to be specified, the existing devices indicate only the total energy available in the storage capacitor. With the aid of the information provided in this report on the effect of different variables on the probability of initiation, refinements were made to the existing techniques so that the test would give a better evaluation of electrostatic hazards. The proposed apparatus is simple, safe, and capable of yielding meaningful and reproducible results. It is able to rank the sensitivity of explosives as well as to distinguish between primary, booster, and main-charge explosives. It avoids the arc discharge and the discontinuous discharge regions (see "Gaseous Discharge Characteristics" in the Results section of this report). To obtain an unambiguous measure of the relative sensitivity to the spark mode with voltages in the 1-5 kV range, the series resistance is in the 100 k Ω range, which limits peak spark current to less than 0.1 A. A special sample holder was designed which will allow the reproducible detection of a limited amount of reaction in the sample. At present, for booster and main-charge explosives, it is difficult to determine whether ignition actually occurred, or whether the smoke observed was just finely divided particles of the explosive dispersed by the discharge. The sample holder confines the explosive for a time long enough to allow a self-sustaining reaction to get underway. Preliminary tests show that a satisfactory sample holder could consist of a 0.9 - 1.6 mm thick nylon or polyethylene washer (4.8 mm i.d.) fastened (or taped with double adhesive tape) to the top of the 19 mm diameter flat steel disc used in the present study, leaving a space 4.8 mm by 0.9 - 1.6 mm high to contain the explosive. Electrical insulating tape (0.19 mm thick) placed over the opening provides adequate confinement. In using the sample holder, the steel needle punctures the tape and a discharge occurs through the interstices of the powder. A reaction is indicated by a severed tape, whereas no reaction is evidenced by a punctured but otherwise intact tape.

At present, there are three different electrostatic sensitivity apparatuses recommended in the Tri-Service Manual (Ref 9) for use in qualifying primary, booster, and main-charge explosives. The apparatus for qualifying primary explosives is the Naval Surface Weapons Center's approaching-needle apparatus (Ref 10,11) designed

and built by Wyatt more than 15 years ago. Although it was a good apparatus for the time, it lacks many required features; for example, a fine adjustment control is needed for setting the gap. There is, in fact, no preset gap requirement in the Navy test procedure. The approaching needle is allowed to come into contact with the base electrode. Consequently, it is not always known whether the initiation is due to discharge in air or to metal contact. Since a knowledge of the type of initiation is very useful, a test with a preset gap of 0.075 to 0.25 mm should be included in the procedure.

Two types of cathode materials are used in the Wyatt's apparatus: either a steel cathode or a rubber conducting cathode. The steel cathode is used to determine the sensitivity of the explosive to oscillatory discharge or to contact discharge. The conducting rubber cathode is used to determine the sensitivity to spark discharge, since the rubber interposes a large resistance (100 k Ω) in series with the gap.

There are several practical problems with the conducting rubber material. The material is not commonly available and is only vaguely specified. Conducting rubber materials may be nonuniform over small areas and their resistance changes with time. Consequently, it is possible that the resistance of small conducting rubber cathode electrodes could vary quite markedly from test to test. In addition, the rubber will burn from the high energy required when testing insensitive explosives, thus making it difficult to distinguish between smoke from the explosive and smoke from the rubber burning. Although Wyatt's apparatus is used for primary explosives, the procedure requires the explosives to be tested at extremely high energies (Table 4). Three of the four storage capacitors deliver energies which are much greater than those required for main-charge explosives.

The electrostatic qualification test apparatus for booster explosives is the Naval Surface Weapons Center's fixed-gap, needle-plane apparatus (Ref 9, 12). It is used to distinguish between primary and booster explosives. The stored energy is 0.5 J but the energy delivered to the gap is unknown. The apparatus was developed to determine the relative sensitivity of explosives, but it may actually measure apparent sensitivity due to the large capacitor (0.01 mfd) charged to a high voltage (10 kV) and the large fixed gap (1.3 mm). Also, according to the procedure, if a gaseous discharge did not occur with an explosive sample at the 1.3 mm gap, the upper electrode was lowered in 0.13 mm steps until a discharge occurred. No distinction is made between the explosives which allow a gaseous discharge to occur at the 1.3 mm gap and those which require the gap to be reduced.

Table 4

Energy characteristics of apparatuses in current use

<u>Type explosive</u>	<u>Capacitance (mfd)</u>	<u>Voltage (kV)</u>	<u>Stored energy (J)</u>	<u>Type test</u>
Primary	1.0	1.5 - 7.5	1.1 - 28	Approaching needle (NSWC)
	0.1	1.5 - 7.5	0.11 - 2.8	
	0.01	1.5 - 7.5	0.011 - 0.28	
	0.001	1.5 - 7.5	0.0011 - 0.028	
Booster	0.01	10	0.5	Fixed-gap (NSWC)
Main charge	0.02	5	0.25	Approaching needle (NWC)
Main charge	0.5	5	6.25	Approaching needle (NOS)
	0.1	5	1.25	
	0.05	5	0.625	
	0.02	5	0.25	
	0.001	5	0.012	
	0.0005	5	0.006	
	0.0001	5	0.001	

22

NSWC in the Naval Surface Weapons Center

NWC is the Naval Weapons Center

NOS is the Naval Ordnance Station

The acceptance test for main-charge explosives is being carried out using the approaching-needle apparatus of either the Naval Weapons Center or the Naval Ordnance Station, Indian Head. The test at the Naval Weapons Center is a pass-fail test to distinguish between main-charge and primary explosives, i.e., explosives which do not fire at a stored energy level less than 0.25 J (0.02 mfd capacitor charged to 5 kV). The test at the Naval Ordnance Station requires a sequence of trials from 6.25 to 0.0001 J (Table 4).

Thus, the test described herein is strongly recommended as a preferred test for the measurement of electrostatic sensitivity.

CONCLUSIONS

1. The improved, approaching-needle apparatus used in the present study satisfies the need for a single, standardized, electrostatic-sensitivity test apparatus and procedure for characterizing explosives. It is simple, safe, and capable of yielding meaningful and reproducible results. In particular, it distinguishes between primary, booster, or main-charge explosives, as well as ranks the electrostatic-sensitivity of an explosive within these categories.
2. The gaseous discharge characteristics of an approaching-electrode apparatus are very similar to those observed for the fixed-gap, parallel-plate apparatus.
3. The fraction of the total stored energy that was dissipated in the gap varies with the circuit parameters, 3 to 6% for arc discharge and 15 to 25% for spark discharge.
4. Higher initiation energy results are obtained under humid conditions or if the discharge does not occur entirely within the sample.
5. With an approaching-electrode apparatus, the energy of initiation of the three primary explosives as determined by gaseous discharge is a strong function of the energy delivery rate. The minimum initiation energy results are considerably less in the spark mode than in either the oscillatory or the arc modes.
6. With the approaching-electrode apparatus, the three primary explosives tested did not vary in rank with mode of discharge found previously for the fixed-gap, parallel-plate apparatus. Basic lead styphnate was much more sensitive than RD1333 lead azide or tetracene in all three discharge modes. Tetracene was the least sensitive.

7. Compacted explosive powder (low density) may be more sensitive (electrostatically) than loose powder (see "Effect of Electrode Configuration on Initiation Probability").

REFERENCES

1. Kirshenbaum, M.S., *Electrostatic Sensitivity of Explosives As a Function of Circuit Parameters*, Proceedings of the DAE-AF-F/G-7304 Technical Meeting, 29 April - 1 May 1974, Naval Surface Weapons Center, Silver Spring, MD
2. Kirshenbaum, M.S., *Response of Lead Azide to Spark Discharges Via a New Parallel-Plate Electrostatic Sensitivity Apparatus*, Technical Report 4559, Picatinny Arsenal, Dover, NJ, June 1973
3. Westgate, C.R., Kirshenbaum, M.S., and Pollock, B.D., *Electrical and Photographic Characterization of Low-Intensity Capacitor Spark Discharges*, Technical Report 4737, Picatinny Arsenal, Dover, NJ, February 1975
4. Explosive Hazard Assessment Manual of Tests: Test No. 6/66, *The Electric Spark Test, Sensitiveness Collaboration Committee Explosives Research and Development Establishment*, Procurement Executive Ministry of Defence, Waltham Abbey, Essex, England, 1966
5. Brown, F.W., Kusler, D.J., and Gibson, F.C., *Sensitivity of Explosives to Initiation by Electrostatic Discharges*, Report of Investigations 5002, Bureau of Mines, September 1953
6. *Hazards Evaluation of the Cast Double-Base Manufacturing Process*, Allegheny Ballistics Laboratory Report ABL/X-47, Contract NOrd 16640, Hercules Powder Co., December 1960
7. Priede, T., *Initiation of Explosion in Gases*, Ph. D. Thesis, University of London, 1958
8. Boyle, A.R. and Llewellyn, J., *Trans. Chem. Ind.*, 69, 173, 1950
9. *Joint Service Safety and Performance Manual for Qualification of Explosives for Military Use*, Joint Technical Coordinating Group for Air Launched Non-Nuclear Ordnance Working Party for Explosives, Picatinny Arsenal, Dover, NJ, 1971

10. Wyatt, R.M.H., *Electrostatic Spark Sensitivity of Bulk Explosives and Metal/Oxidant Mixtures*, NAVORD 6632, Naval Surface Weapons Center, Silver Spring, MD, June 1959
11. Montesi, L.J., *The Electrostatic Spark Sensitivity of Various Organic Explosive and Metal/Oxidant Mixtures*, NOLTR 65-124, Naval Surface Weapons Center, Silver Spring, MD, March 1966
12. Montesi, L.J., *The Development of a Fixed Gap Electrostatic Spark Discharge Apparatus for Characterizing Explosives*, Proceedings Sixth Symposium on Electroexplosive Devices, The Franklin Institute, Philadelphia, PA, 1969



APPENDIX A
DESCRIPTION OF APPARATUS



The approaching-electrode apparatus consisted of a charging circuit, an approaching-electrode assembly, and a recording system.

Charging Circuit

High voltage was provided by a Beckman variable 0 to 25 kilovolt power supply. The voltage was measured with a model ESD Sensitive Research electrostatic voltmeter, ranges: 0 to 2000 V, 1500 to 5000 V, and 2000 to 10,000 V. Low inductance, high voltage, ceramic-cased, extended-foil capacitors (PK series) from Del Electronics Corporation were used as the energy-storage-discharge capacitors. The circuit was designed so that the appropriate capacitance, from 54 to 50,000 pF, could be manually connected in the circuit, as either a single capacitor or a group of capacitors in parallel, by double-pronged bridge plugs with nonconductive plastic handles. The capacitance of the storage capacitors and the stray capacitance of the electrical leads in parallel with the storage capacitor were measured in situ in the circuit using a General Radio Company Type 1656 Impedance Bridge. The stray inductance responsible for the oscillatory discharge was calculated from the decay of the current trace as a function of time by means of the following formula:

$$L = \frac{(t_2 - t_1)^2}{C \left[4\pi^2 + \left(\ln \frac{I_1}{I_2} \right)^2 \right]}$$

where L is the inductance in henries, C is the capacitance in farads, and t_1 and t_2 are the times in seconds for the values of two consecutive peak currents, I_1 and I_2 . The stray inductance of the experimental apparatus was approximately 1.3 microhenries. The resistance of the gap is dependent upon the gap length. The resistance of the discharge circuit with a 0.18 mm gap was calculated from the decay of the current trace as a function of time by means of the following formula:

$$R = \frac{(t_2 - t_1)^2}{C \left[4\pi^2 + \left(\ln \frac{I_1}{I_2} \right)^2 \right]}$$

where R is the resistance in ohms. The calculated resistance of the experimental apparatus with a 0.18 mm gap was approximately 7.5 ohms. The capacitor output is connected to the approaching-electrode assembly. A current-limiting resistor may be placed between the charged capacitor

and the electrode assembly. High voltage carbon film resistors (Resistance Products Company) were used as the current-limiting resistors. A schematic of the charging circuit is shown in Figure 4.

Approaching-Electrode Assembly

The approaching-electrode assembly (Fig 5) was a spring-operated device in which the upper electrode was rapidly lowered to a preset distance above the base electrode and immediately raised again to its initial position. Adjustments in the gap length were made by raising or lowering the flat, lower (base) electrode by means of a micrometer, which was connected to the lower electrode and was located outside the firing chamber. The approaching-electrode assembly could be used in the conventional point-to-point configuration (Fig 6) or a plane-plane geometry (Fig 7). This was accomplished by attaching to the vertical, actuating rod of the approaching assembly either a phonograph needle holder with a removable steel phonograph needle (Fig 8) or a pin holder with a removable steel pin.

A schematic diagram showing the principle of operation of the approaching-electrode assembly is given in Figure 9. Either a needle electrode or a plane-pin electrode "A" was mounted on a vertical actuating rod "B", which was free to slide through the guide housing "C". Handle "D" was connected to the toggle level assembly "E" and the spring "F". The spring was attached to a wall hook "G". When the handle was pulled to the left position (cocked position), the toggle level assembly raised the vertical actuating rod and engaged the release rod "H". The spring was under maximum tension at this point. When the release rod was pulled, the spring contracted, thereby rapidly lowering the vertical actuating rod to its lowest position and immediately raising it again to its initial position. Handle "D" must be pulled to the left again to cock the device for another trial.

The high-voltage power supply was disconnected from the discharge circuit during the gap-closing operation (Fig 4). In the raised position, the storage capacitor was connected to the high-voltage source. As soon as the approaching electrode started to move downward, the high voltage contact was broken, thus disconnecting the high side of the capacitor from the charging source during discharge. For safety, a high-voltage, double-pole, double-throw pressurized relay (switch) was included to prevent the capacitor from being recharged in the raised position until the reset button was pushed. The relay also discharged to ground any residual voltage remaining in the discharge circuit after the discharge operation was completed.

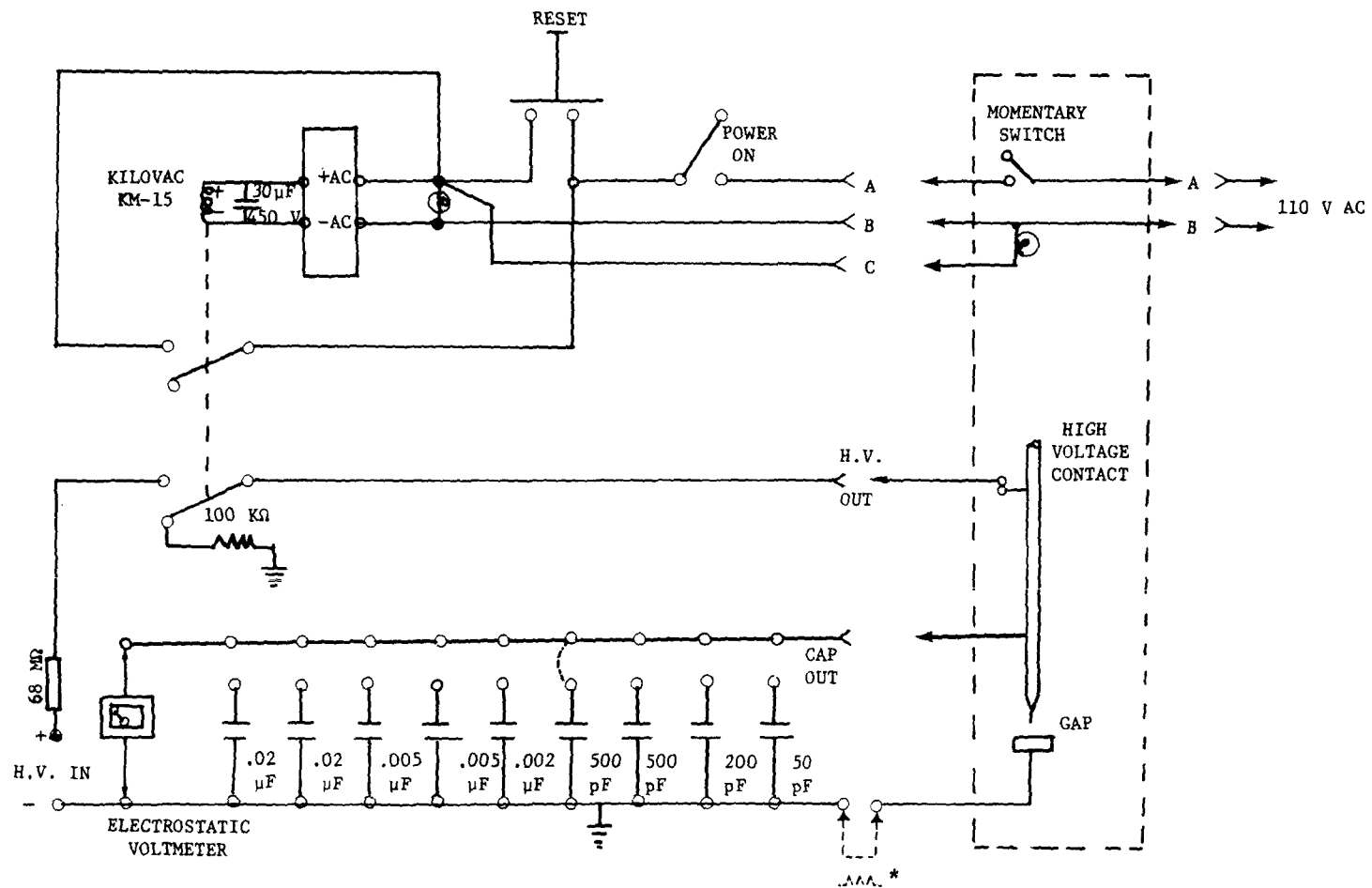

*A 2 k Ω or a 100 k Ω resistor is added to produce the arc or the spark discharge, respectively. No resistance is added for the oscillatory discharge.

Fig 4 Charging circuit

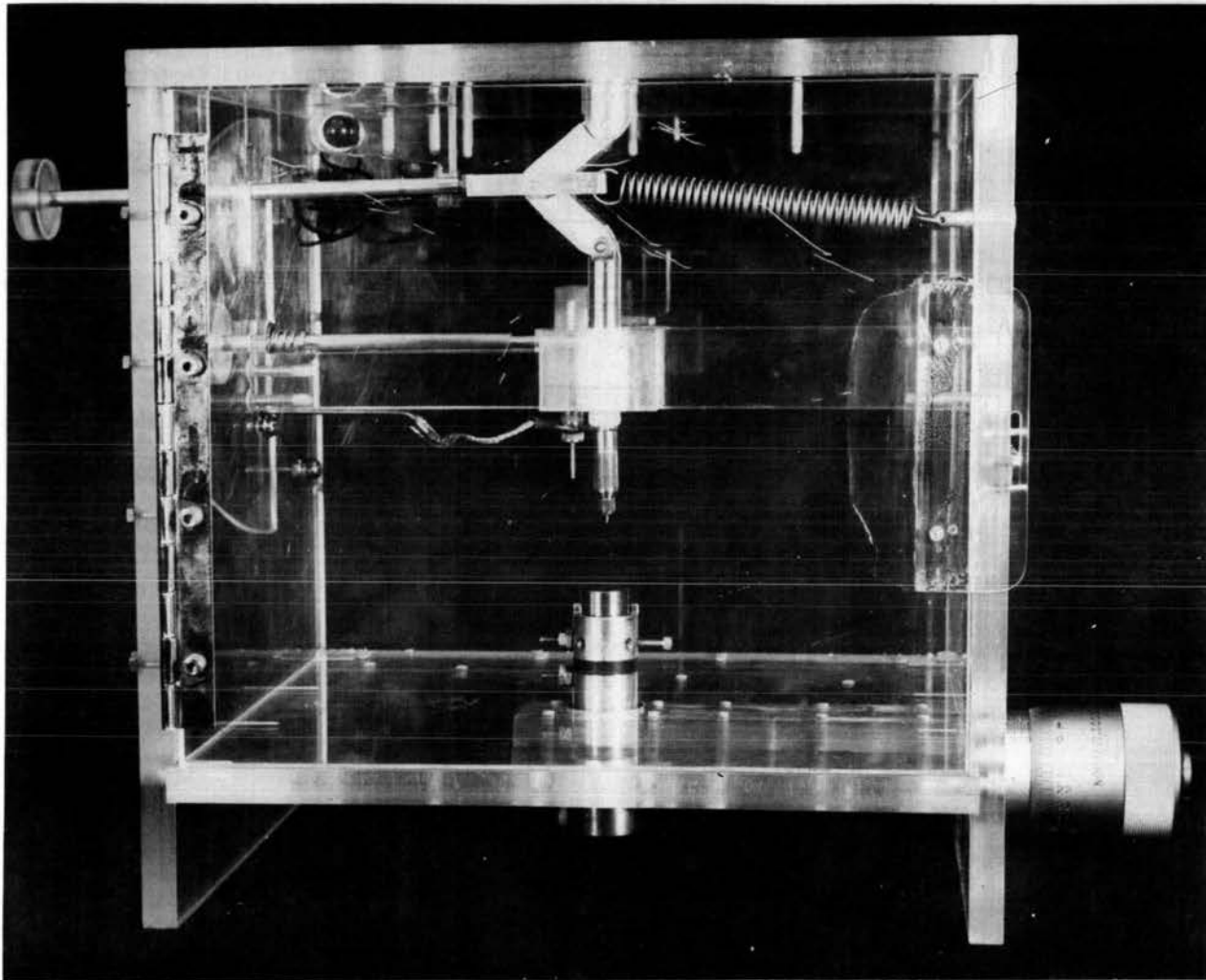

Fig 5 Approaching-electrode assembly

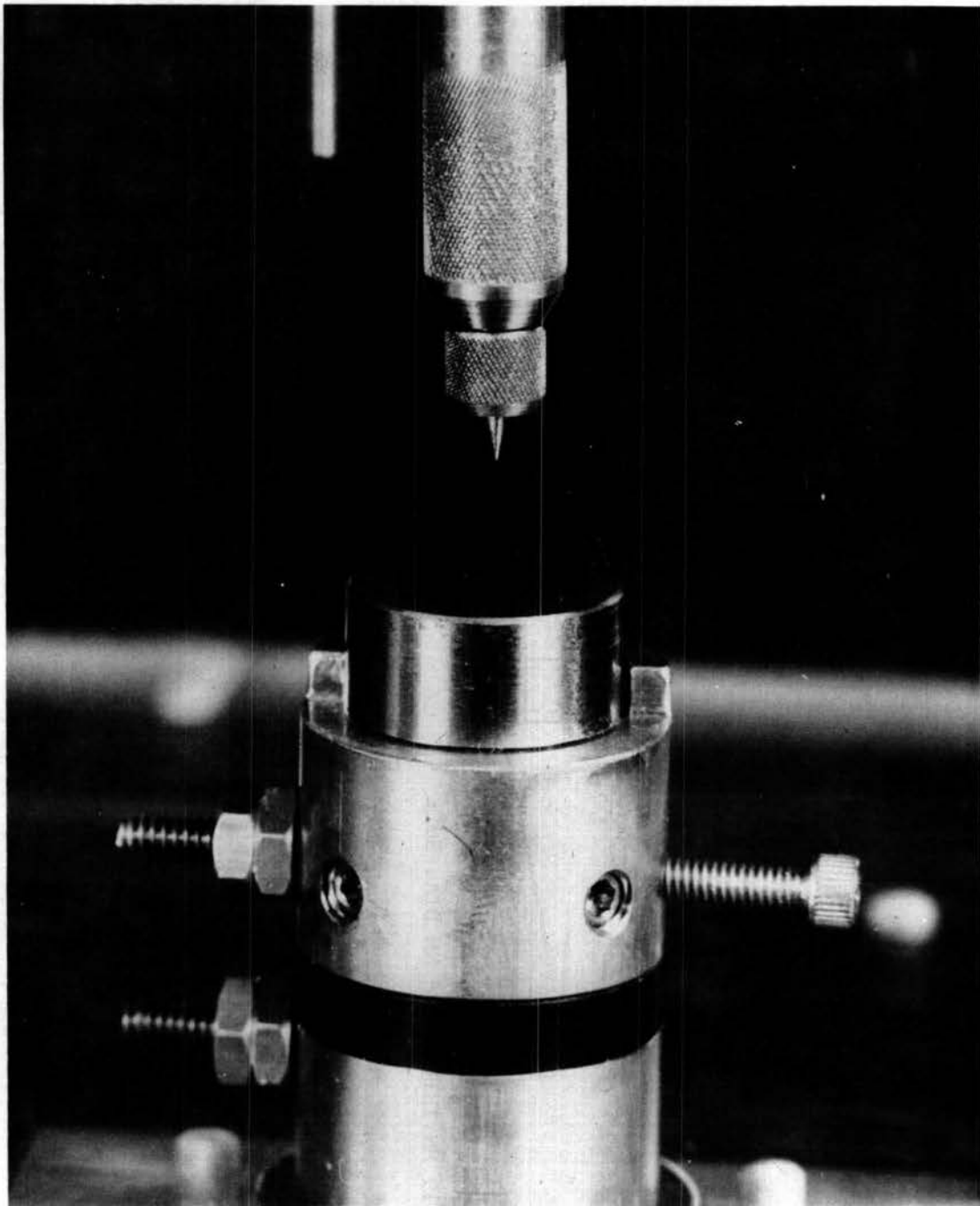

Fig 6 Needle-plane electrode assembly

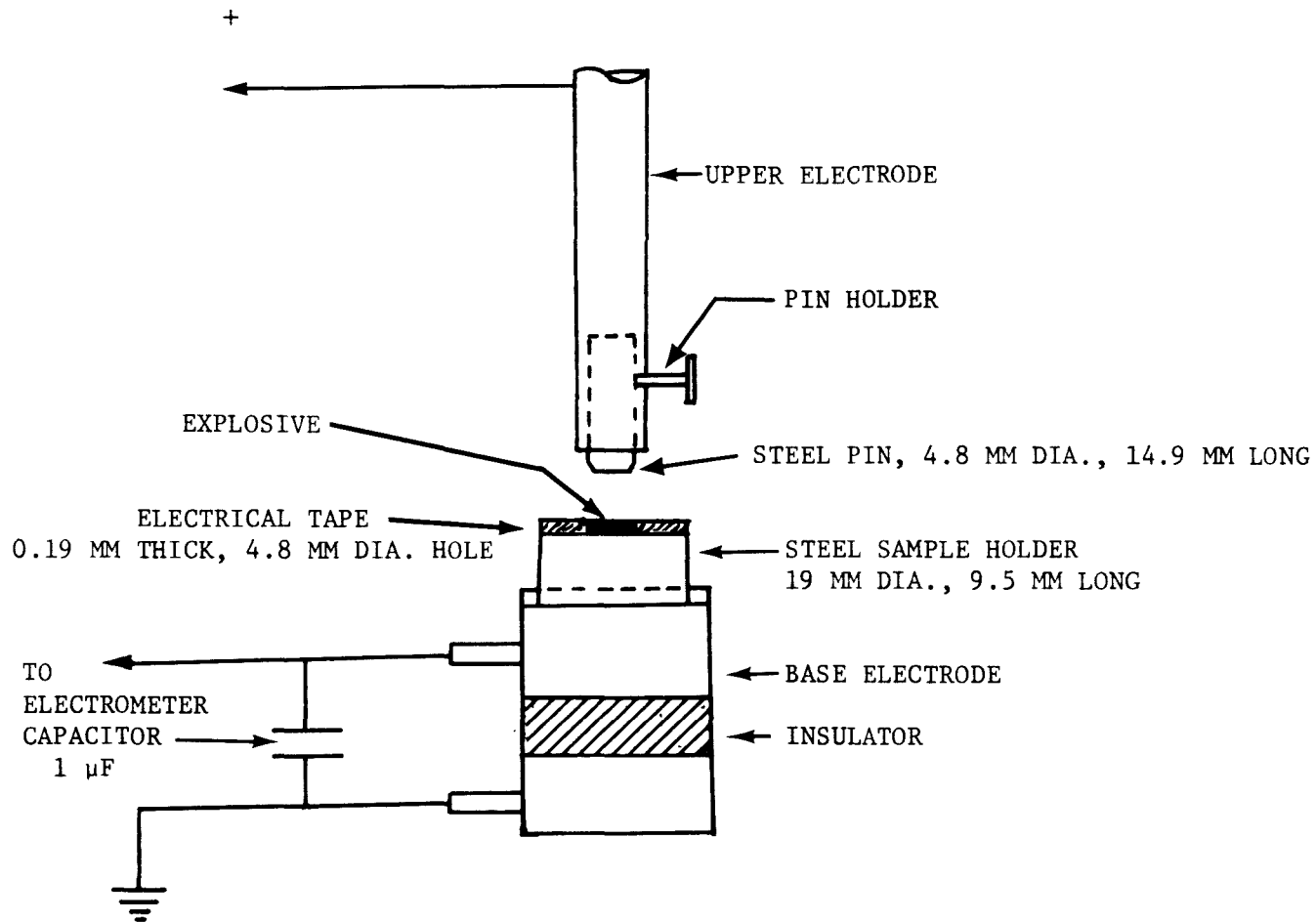

Fig 7 Plane-to-plane electrode assembly

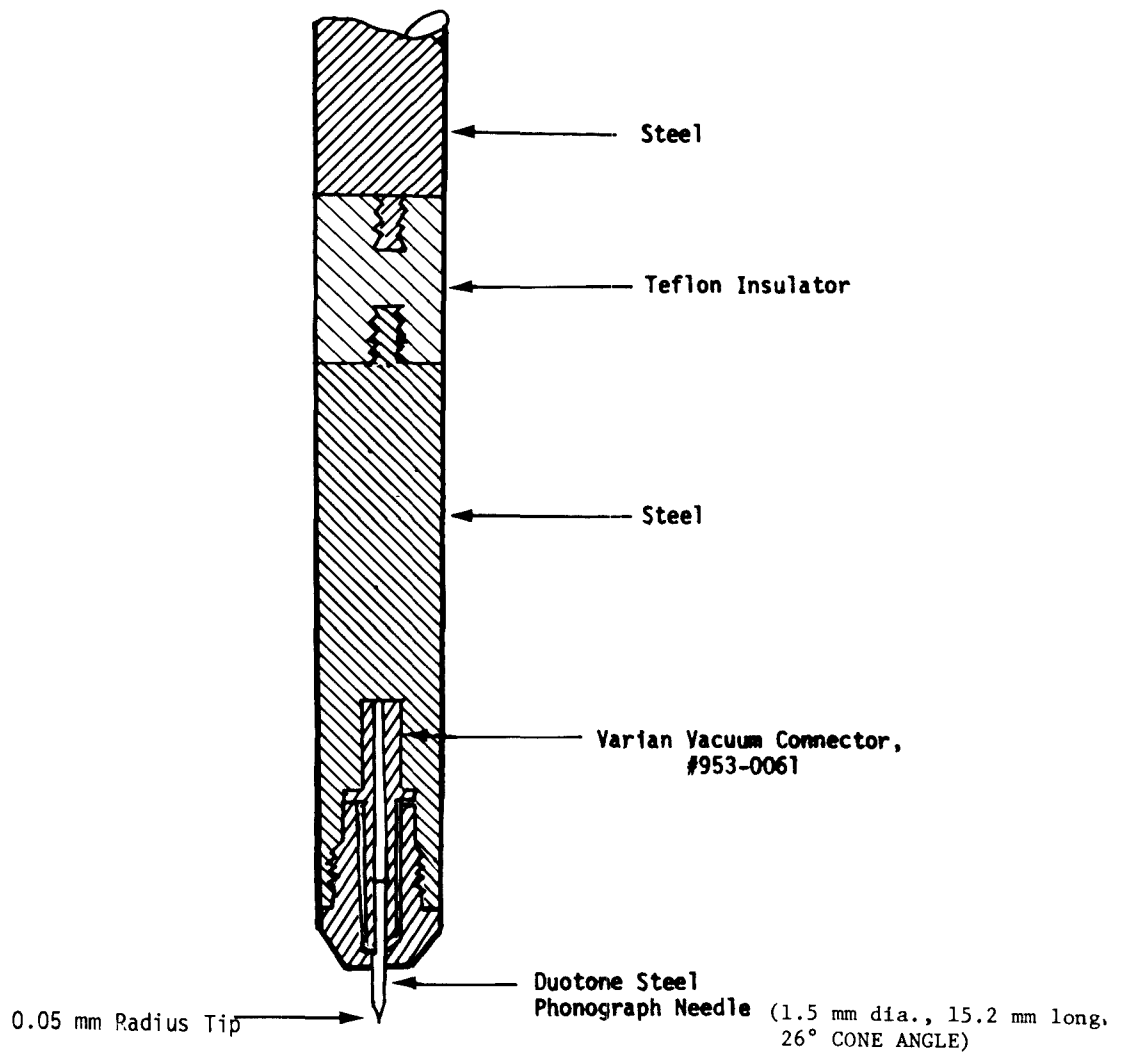

Fig 8 Needle assembly

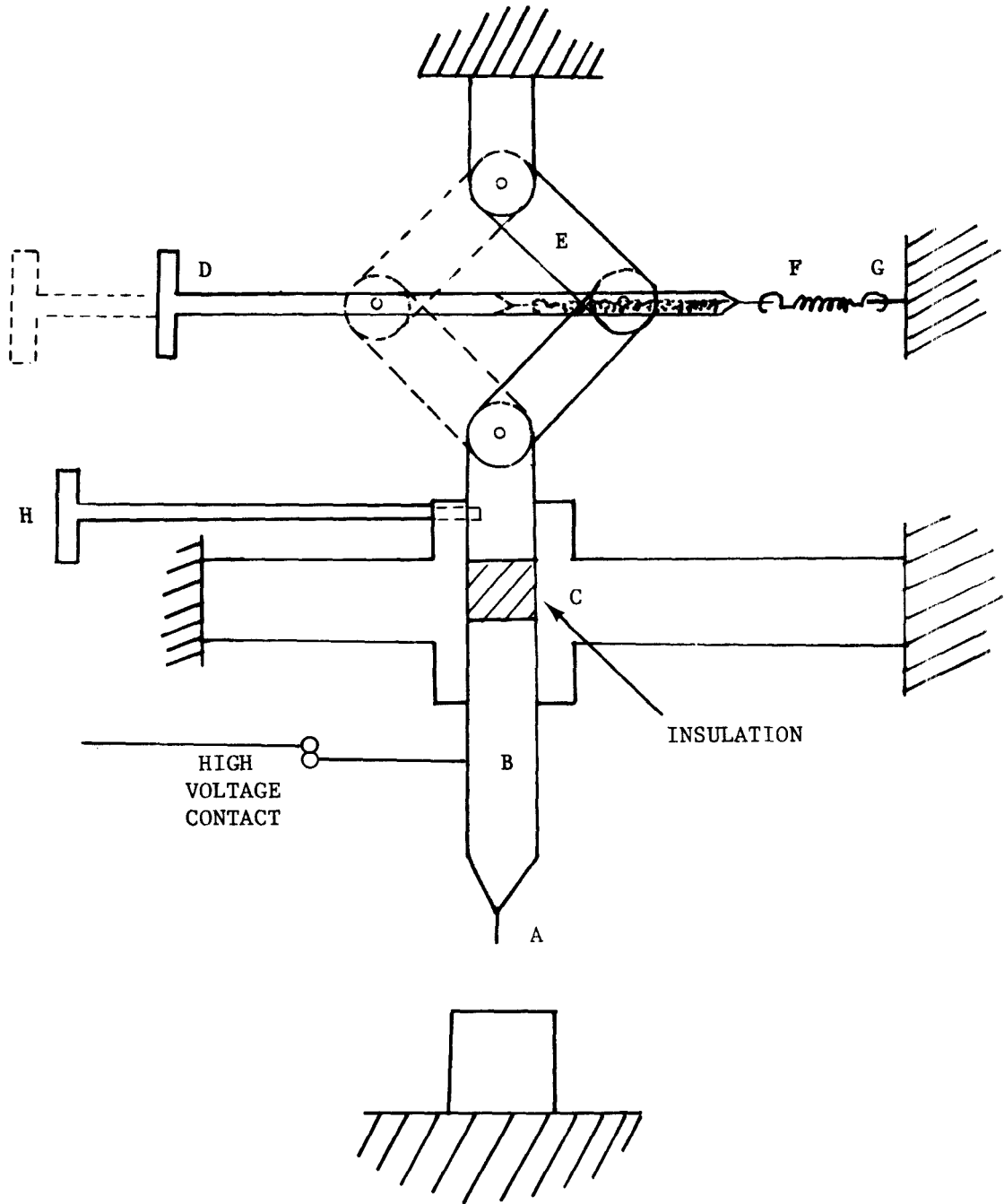

Fig 9 Schematic showing operation of approaching assembly

The upper portion of the base, or lower electrode, served as the explosive sample holder. It was a detachable, solid cylinder of hardened steel, 19 mm diameter by 9.5 mm long. When the approaching electrode was a steel pin (plane-plane geometry) a layer of 0.19 mm thick electrical tape with a 4.8 mm diameter hole for the explosive was taped to the top surface of the steel cylinder. The removable steel pin had a 4.8 mm diameter, 14.9 mm length and rounded edges on the flat ends. The explosive powder was semiconfined between the plane pin and the sample holder. The desired gap between the upper electrode and the sample holder was set and maintained by a micrometer, the latter was connected to the base electrode and was located outside the firing chamber. This gap length was accomplished in the dynamic mode since the gap length setting varies depending on whether the upper electrode is depressed dynamically or remains stationary. The gap was set by first adjusting the micrometer until the electrodes just touched in the dynamic mode. A peak-reading voltmeter and a 6 V battery were connected between the two electrodes to aid in this determination. The base electrode was then lowered the desired length, usually 0.18 mm.

The firing chamber (29.2 cm cube) was made of 1.27-cm thick, clear polymethyl methacrylate (PMMA) and sized to fit into an available humidity control box for future controlled humidity experiments. To reduce charge build-up on the PMMA, the plastic was coated with a layer of an anti-static agent. The chamber should be made of a plastic with a conductive coating and the chamber grounded.

Recording System

The current and voltage characteristics of the gaseous discharge were recorded photographically on a Tektronix 7623 storage oscilloscope. The voltage across the spark gap was determined by direct measurement with a Tektronix P6013A, 1000X attenuator, voltage probe. The current through the gap was determined with a Tektronix CT-2 current transformer or by measuring the voltage drop across a 3.3 ohm resistor in series with the gap. The instantaneous current was taken as V_R/R , where V_R was the instantaneous potential drop across the 3.3 ohm resistor, R . The total charge flowing through the gap was determined by using a Keithley 610C electrometer to measure the final voltage across a one microfarad capacitor in series with the gap. (See section of results entitled Efficiency of Energy Dissipated in the Gap.)

Safety Features

The apparatus incorporated several safety features to protect the operator. The high-voltage power supply was connected to the storage capacitor by means of the high-voltage double-pole, double-throw relay switch (KILOVAC KM-15). The relay switch could not be energized until a series of switches were closed. In the deenergized (open) position, the relay switch shorted to ground the storage capacitor and the approaching-electrode assembly. It also shorted to ground any residual voltage which may have remained in the discharge circuit after the discharge operation was completed. A momentary and a reset switch were in series in the coil circuit of the relay switch. The momentary switch was connected to the approaching-electrode assembly and was closed mechanically by it only when the assembly was cocked in the raised position. The reset switch prevented the storage capacitor from being charged accidentally when the electrode was in the raised position. The reset switch had to be closed manually and could only function after all the other switches in series were closed. It opened automatically whenever any switch was opened and had to be reclosed manually.

In the proposed design for the Tri-Services, the door of the firing chamber should be provided with an interlock switch, which will be connected in the coil circuit of the relay switch. When the door is opened, the relay will be deenergized, which will automatically disconnect the high-voltage power supply from the storage capacitor and short to ground the charged capacitor and the approaching-electrode assembly. The proposed electrical circuit is shown in Figure 10.

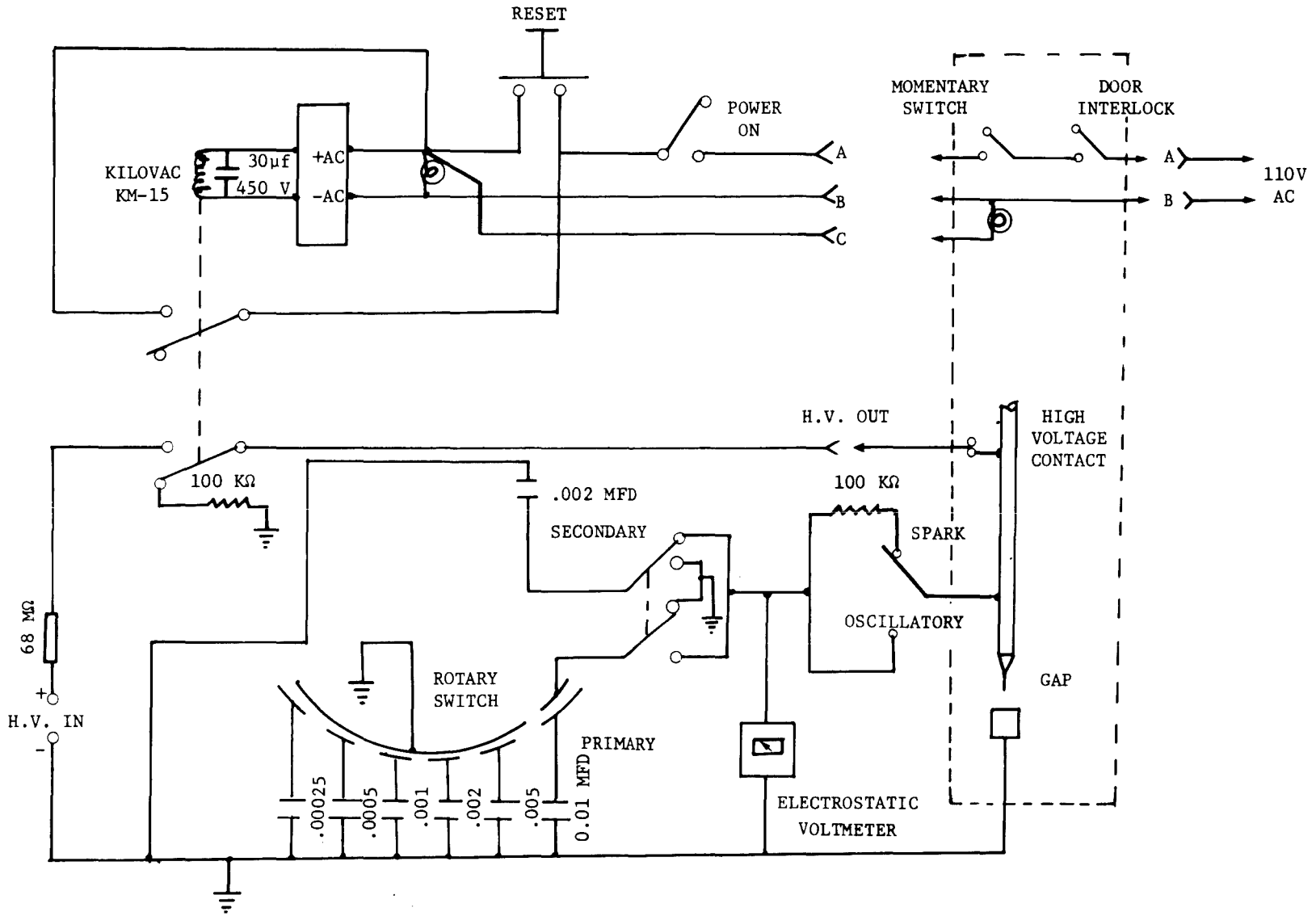
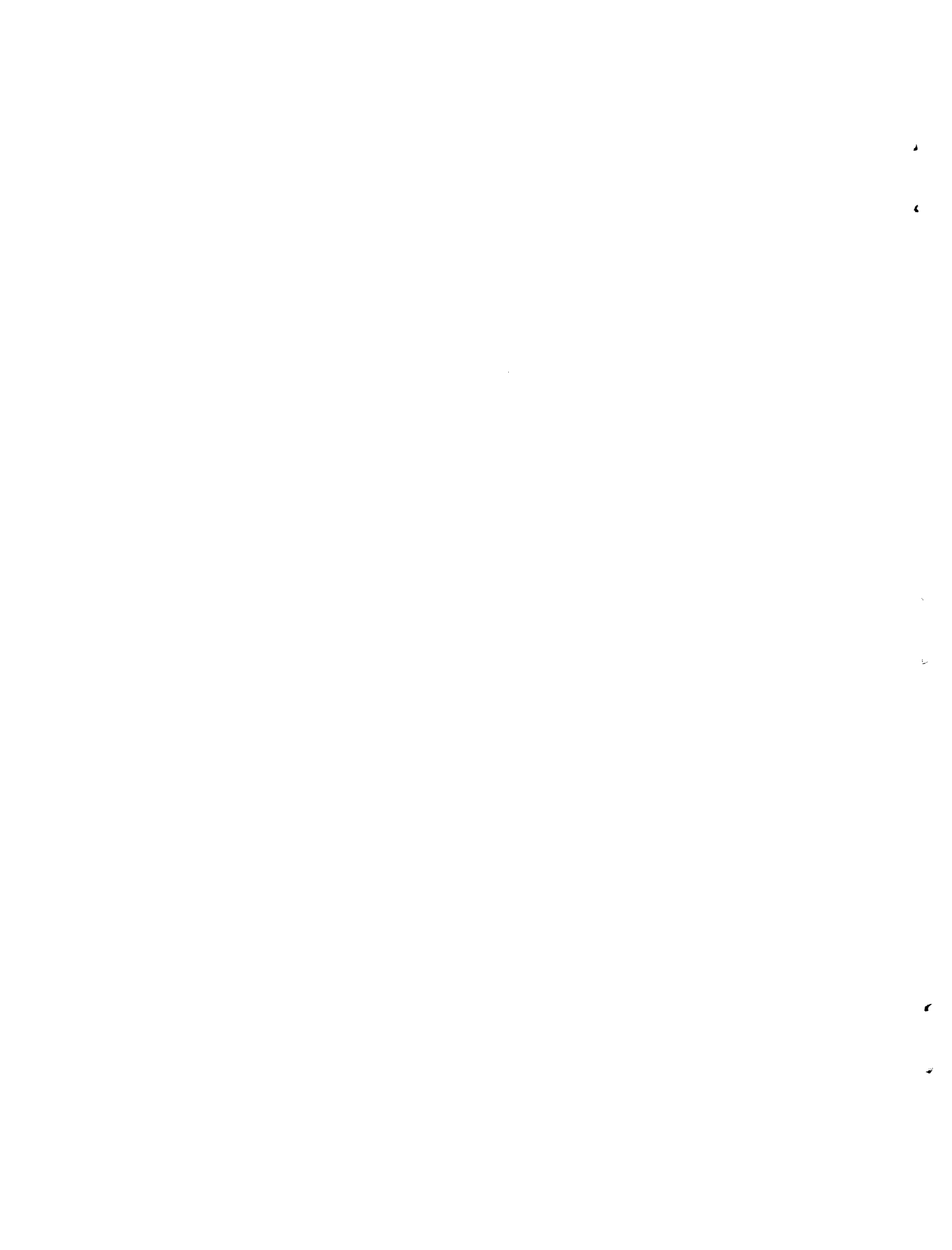

Fig 10 Proposed electrical circuit



APPENDIX B
PROPOSED ELECTROSTATIC SENSITIVITY TEST PROCEDURE



The electrostatic-sensitivity test is divided into two parts, Part I, a screening test to distinguish between primary, booster, or main-charge explosives and Part II, an optional test using a more intensive procedure to rank or compare primary explosives. The approaching-needle apparatus in Appendix A is used for all the tests. The unit is designed to provide an electrostatic discharge at any voltage up to 5 kV from any capacitance from 250 pF to 0.01 mfd. The discharge occurs across an adjustable gap. Explosives are tested confined in either the powder or granular state. The sensitivity level reported is the highest energy level at which no reaction occurred in 25 trials. A reaction is indicated by a severed confining tape, whereas no reaction is evidenced by a punctured but otherwise intact tape.

In Part I, the test materials are to be assessed by using an oscillatory discharge. The energy for this test was fixed at 0.020 J, which is the charge energy that an ungrounded person can accumulate (Ref 4, 5). However, this value is about five times the maximum energy that an ungrounded person could discharge (Ref 6). There is no electrostatic distinction between booster and main-charge explosives. Those materials which are ignited at the 0.02 J level are in the primary explosive category and are relatively sensitive. A further study is recommended according to the procedure in Part II to determine what other precautions are likely to be required. Part II is optional. In this test, primary explosives are to be assessed using oscillatory, spark, and contact discharges.

Test Procedure - Part I

The test materials shall be subjected to an oscillatory discharge.
To operate:

1. Set selector switch to "secondary". (This connects the 0.002 mfd capacitance (high-capacitance bank) to the discharge circuit and shorts the low-capacitance bank to ground.)
2. Set resistance switch to "oscillatory" discharge. (No series resistance is connected for an oscillatory discharge, whereas 100 k Ω resistance is connected in series for a spark discharge.)

3. Set electrode spacing (gap) to 0.18 mm (0.007 inch). This is accomplished in the dynamic mode because the gap length setting is different depending on whether the upper electrode is depressed dynamically or remains static. The gap is set by adjusting the micrometer (attached to the base electrode) until the electrodes just touch when the upper electrode is depressed dynamically. A peak-reading voltmeter and a 6 V battery or equivalent may be connected between the two electrodes to aid in this determination. The base electrode is then lowered 0.18 mm by means of the micrometer. It shall be necessary to readjust the electrode spacing before starting a test or when the upper electrode (needle) is replaced.

4. Place sample holder containing the test material, prepared according to paragraph "Sample Preparation", on the base electrode with the powder directly under the needle. Raise the upper electrode to cocked position by means of handle "D". Close the door (door must be closed to engage interlock).

5. Turn on power supply and adjust voltage control to 4.5 kV.

6. Activate reset switch to charge the capacitor. Adjust power supply until the electrostatic voltmeter reads 4.5 kV.

7. Pull release rod "H" to release the approaching electrode. The charged electrode will rapidly move downwards to the preset gap distance. The needle will puncture the tape, penetrate the sample material, discharge through the interstices of the material, and rise again to its initial position. (The threshold voltage for gap breakdown will determine the distance at which the needle will be above the base electrode when the discharge occurs.)

8. Record reaction or no reaction. A reaction is indicated by a severed tape, whereas no reaction is evidenced by a punctured but otherwise intact tape.

9. Repeat the procedure until no reaction is obtained in 25 consecutive trials. If a reaction is obtained, discontinue the test and record that explosive falls in the primary category.

Qualification Criterion

An explosive shall be reported to have passed the electrostatic sensitivity test and to be acceptable as a booster or main-charge explosive if there are no reactions in the 25 consecutive trials at the 0.02 J level (0.002 mfd capacitor charged to 4.5 kV) .

Sample Preparation

Materials are normally tested dry, in either the powdered or the granular state. The materials shall be stored in desiccators for at least 24 hours prior to test. For cast, molded, and cured extruded explosives, it shall be necessary to pulverize the cured or formed samples in a ball mill. Explosives containing binders or solvents or with curing binders shall be dried, then ground in a ball mill using a dispersing fluid in which none of the ingredients, including the binder, are soluble and finally heated to constant weight at 65°C. Since some explosives are subjected to segregation with respect to particle size or components of mixture, care shall be exercised to insure that the material actually used constitutes a representative sample, with respect to both particle size distribution and composition.

The explosive powder shall be placed in the sample holder. The sample holder shall consist of a 0.9 - 1.6 mm thick nylon washer (4.8 mm i.d.), or equivalent, fastened (double adhesive tape may be used) to the top of a 19 mm (3/4") diameter, flat steel disc leaving a space 4.8 mm diameter by 0.9 to 1.6 mm high to contain the explosive. Electrical insulating tape, 0.19 mm thick, shall be placed over the explosive opening to confine the explosive sample. The sample holder shall then be placed on the base electrode with the powder directly under the needle.

Electrode Replacement

The needle (upper electrode) shall be wiped with a "kimwipe", or equivalent absorbent paper, after every trial. The needle shall be placed and the steel sample holder shall be cleaned and polished after any trial in which there is evidence of a reaction, whenever a test of a new material is started, or when any other condition dictates. In any event, the number of trials prior to cleaning should not exceed ten. Cleaning is done using first, No. 400, then No. 600 emery cloth, and finally, polishing with crocus cloth.

Relative Humidity

The relative humidity shall not exceed 40%. Humidity shall be determined by wet and dry bulb hygrometry or by any other instrument of equal or better accuracy. The firing chamber of the tester may be maintained at the required humidity by continuously passing dry air through the chamber.

Test Procedure - Part II (Optional)

The test material shall be subjected to contact discharge as well as to an oscillatory and to a spark discharge. The oscillatory and the spark discharge tests shall be as follows:

1. Set selector switch to "primary". (This connects the bank of low capacitances to the discharge circuit and shorts the high capacitance bank to ground.)
2. Set resistance switch to "oscillatory" or "spark" discharge. (No series resistance is connected for an oscillatory discharge, while a 100 k Ω resistance is connected in series for a spark discharge.)
3. Set primary capacitance switch to the selected capacitance; 2,000, 1,000, 500, or 250 pF, for oscillatory discharge, and 10,000, 5,000, 2,000, 1,000, 500, or 250 pF, for spark discharge. The starting capacitance is usually the largest value unless a more efficient value based on experience is known.
4. Set electrode spacing (gap) to 0.18 mm (0.007 in.). This is accomplished in the dynamic mode since the gap length is different depending on whether the upper electrode is depressed dynamically or remains static. The gap is set by adjusting the micrometer (attached to the base electrode) until the electrodes just touch when the upper electrode is depressed dynamically. A peak-reading voltmeter and a 6 V battery, or equivalent, may be connected between the two electrodes to aid in this determination. The base electrode is then lowered 0.18 mm by means of the micrometer. It shall be necessary to readjust the electrode spacing before starting a test or when the upper electrode (needle) is replaced.

5. Place sample holder containing the test material (prepared according to paragraph "Sample Preparation" in Part I) on the base electrode with the powder directly under the needle. Raise upper electrode to cocked position by means of handle "D". Close the door. (Door must be closed to engage interlock.)

6. Turn on power supply and adjust voltage control for desired voltage.

7. Activate reset switch to charge the capacitor. Adjust power supply until the electrostatic voltmeter reads the selected voltage. The starting voltage is 4 kV except for either 2,000 pF capacitance (oscillatory discharge) or for 10,000 pF capacitance (spark discharge), when the voltage is to be set at 4.5 or 5 kV, respectively.

8. Pull release rod "H" to release the approaching electrode. The charged electrode will rapidly move downwards to the preset gap distance. The needle will puncture the tape, penetrate the sample material, discharge through the interstices of the material, and rise again to its initial position. (The threshold voltage for gap breakdown will determine the distance at which the needle will be above the base electrode when the discharge occurs.)

9. Record reaction or no reaction. A reaction is indicated by a severed tape, whereas no reaction is evidenced by a punctured, but otherwise intact, tape.

10. Repeat the procedure until no reaction is obtained in 25 trials. If a reaction is obtained, the energy is reduced by decreasing the potential on the capacitor in 500 V increments and the above procedure repeated. The voltage is reduced until the charging voltage is 2500 V and then the next lower capacitance is selected by means of the primary capacitance switch. (Note: Turn off the power supply before changing capacitance.) The test shall be conducted for both oscillatory and for spark discharges.

11. The results are reported as "No reaction at ___J for oscillatory discharge" and "No reaction at ___J for spark discharge" according to the following table.

Oscillatory Discharge

<u>Capacitance (pF)</u>	<u>Voltage (V)</u>	<u>Approx. delivered energy (10^{-7} J)</u>
2,000	4,500	200,000
	4,000	160,000
	3,500	120,000
	3,000	90,000
	2,500	62,000
1,000	4,000	80,000
	3,500	60,000
	3,000	45,000
	2,500	31,000
500	4,000	40,000
	3,500	30,000
	3,000	22,000
	2,000	15,000
250	4,000	20,000
	3,500	15,000
	3,000	11,000
	2,000	7,500

Spark Discharge

<u>Capacitance (pF)</u>	<u>Voltage (V)</u>	<u>Approx. delivered energy (10^{-7} J)</u>
10,000	5,000	200,000
	4,500	150,000
	4,000	125,000
	3,500	100,000
	3,000	75,000
	2,500	50,000

Spark Discharge (continued)

<u>Capacitance (pF)</u>	<u>Voltage (V)</u>	<u>Approx. delivered energy (10^{-7} J)</u>
5,000	4,000	65,000
	3,500	50,000
	3,000	37,000
	2,500	25,000
2,000	4,000	26,000
	3,500	20,000
	3,000	15,000
	2,500	10,000
1,000	4,000	13,000
	3,500	10,000
	3,000	7,500
	2,500	5,000
500	4,000	6,500
	3,500	5,000
	3,000	3,800
	2,500	2,500
250	4,000	3,200
	3,500	2,500
	3,000	2,000
	2,500	1,250

12. Conduct another series of tests for contact discharge.
13. Set resistance switch to "oscillatory".
14. Set primary capacitance switch to the selected capacitance, 1,000, 500, or 250 pF.
15. With the upper electrode completely depressed dynamically, adjust base electrode for zero gap (electrodes touching) by means of the micrometer. It shall be necessary to readjust for zero gap before starting a test or when the upper electrode (needle) is replaced.

16. Repeat steps 5 through 9 except that the starting voltage is 1,000 V and discharge is obtained only upon contact.

17. Repeat procedure until no reaction is obtained in 25 trials. If a reaction is obtained, the delivered energy is reduced by decreasing the potential on the capacitor from 1,000 V to 500 V to 250 V and/or changing the capacitance to the next lower value. (Note: Turn off the power supply before changing capacitances.)

18. The result is reported as "No reaction at ___J for contact" according to the following table.

Contact Discharge

<u>Capacitance (pF)</u>	<u>Voltage (V)</u>	<u>Approx. delivered energy (10^7 J)</u>
1,000	1,000	5,000
	500	1,250
	250	310
500	1,000	2,500
	500	625
	250	150
250	1,000	1,250
	500	310
	250	75

Qualification Criterion

There is no qualification for this test. The test results shall be reported along with those for normal lead styphnate and dextrinated lead azide obtained using the same apparatus and procedure and conducted at the same time.

Sample Preparation, Electrode Replacement, and Relative Humidity

See Electrostatic Sensitivity - Part I.

DISTRIBUTION LIST

	<u>Copy No.</u>
Defense Documentation Center Cameron Station Alexandria, VA 22314	1-12
Commander US Army Materiel Development & Readiness Command ATTN: DRCDE	13
DRCDMD-ST	14
5001 Eisenhower Avenue Alexandria, VA 22333	
Commander US Army Armament Command ATTN: DRSAR-RDT	15
DRSAR-SF	16
Rock Island, IL 61201	
Commander DARCOM Field Safety Activity ATTN: DRXOS-ES	17
Charlestown, IN 47111	
Commander US Army Ballistic Research Laboratories ATTN: Technical Library	18
Dr. P.M. Howe	19
Dr. K. White	20
Dr. K. Anderson	21
Aberdeen Proving Ground, MD 21005	
Commander Frankford Arsenal ATTN: Technical Library	22
Philadelphia, PA 19137	

Commander
Harry Diamond Laboratories
ATTN: Technical Library 23
Washington, DC 20438

Commander
Picatinny Arsenal
ATTN: SARPA-TS-S 24-28
SARPA-S 29
SARPA-AD-E-P, Mr. D. Seeger 30
SARPA-FR-E, Dr. H. Matsuguma 31
SARPA-FR-E-P, Mr. J. Hershkowitz 32
SARPA-FR-E-P, Mr. W. Voreck 33
SARPA-FR-E-P, Mr. M.S. Kirshenbaum 34-58
Dover, NJ 07801

Commander
US Naval Surface Weapons Center
White Oak Laboratory
ATTN: Technical Library (Code 242) 59
Mr. I. Kabik 60
Mr. L. Ayres 61
Mr. H. Leopold 62
Mr. I. Montesi 63
Silver Spring, MD 20910

Commander
US Naval Weapons Center
ATTN: Technical Library 64
Dr. H. Gryting 65
China Lake, CA 93555

Commander
US Ordnance Station
ATTN: Technical Library 66
Indian Head, MD 20640

Commander
Armament Development & Test Center
ATTN: AFB Technical Library 67
Dr. L. Elkins (ADTC/DLIW) 68
Eglin Air Force Base, FL 32452

Commander Iowa Army Ammunition Plant Silas Mason, Mason & Hanger, Inc ATTN: Technical Library Mr. J. Polson Burlington, IA 52601	69 70
Commander Lone Star Army Ordnance Plant ATTN: Technical Library Mr. S. Nettles Texarkana, TX 75501	71 72
Commander Kansas Army Ammunition Plant ATTN: Mr. E. Nabrey Parsons, KS 67357	73
Bureau of Mines Explosives Research Laboratories ATTN: Dr. R. Van Dolah Pittsburgh, PA 15230	74
Los Alamos Scientific Laboratory ATTN: Technical Library GMX-2, Dr. L. Smith Dr. T.E. Larson Los Alamos, NM 87544	75 76 77
Lawrence Livermore Laboratory ATTN: Technical Library Dr. R. McGuire PO Box 808 Livermore, CA 94550	78 79
Sandia Corporation ATTN: Dr. T. Tucker Dr. N. Brown Mr. C. Scott Technical Library Albuquerque, NM 87115	80 81 82 83

The Johns Hopkins University ATTN: Dr. C.R. Westgate Electrical Engineering Dept Baltimore, MD 21218	84
Rutgers University ATTN: Professor L. Rosenthal Electrical Engineering Dept Murray Hall New Brunswick, NJ 08903	85
Dr. J. A. Brown Consultant PO Box 145 Berkeley Heights, NJ 07922	86
Monsanto Research Corporation Mound Laboratory ATTN: Mr. L. D. Haws Miamisburg, OH 45342	87
ICI America, Inc Atlas Explosives Division Reynolds Experimental Laboratory ATTN: Mr. F.B. Janoski PO Box 271 Tamaqua, PA 18252	88
Jet Propulsion Laboratory ATTN: Mr. V. Menichelli 4800 Oak Grove Drive Pasadena, CA 91103	89
Hercules, Inc Alleghany Ballistics Laboratory ATTN: Mr. R.E. Hunt PO Box 210 Cumberland, MD 21502	90

AD A 033 118

(LJ PATR 4955

c. 24, 25, 26, 27, 28,

c. 25, 26, 27, 28,