

AD-A033 138

MASSACHUSETTS INST OF TECH CAMBRIDGE ACOUSTICS LAB
SONAR SIGNAL ANALYZER Q-4X.(U)
APR 58 G FARRELL

F/G 17/1

UNCLASSIFIED

NOBSR-64653

NL

1 OF 2
AD A033138
138

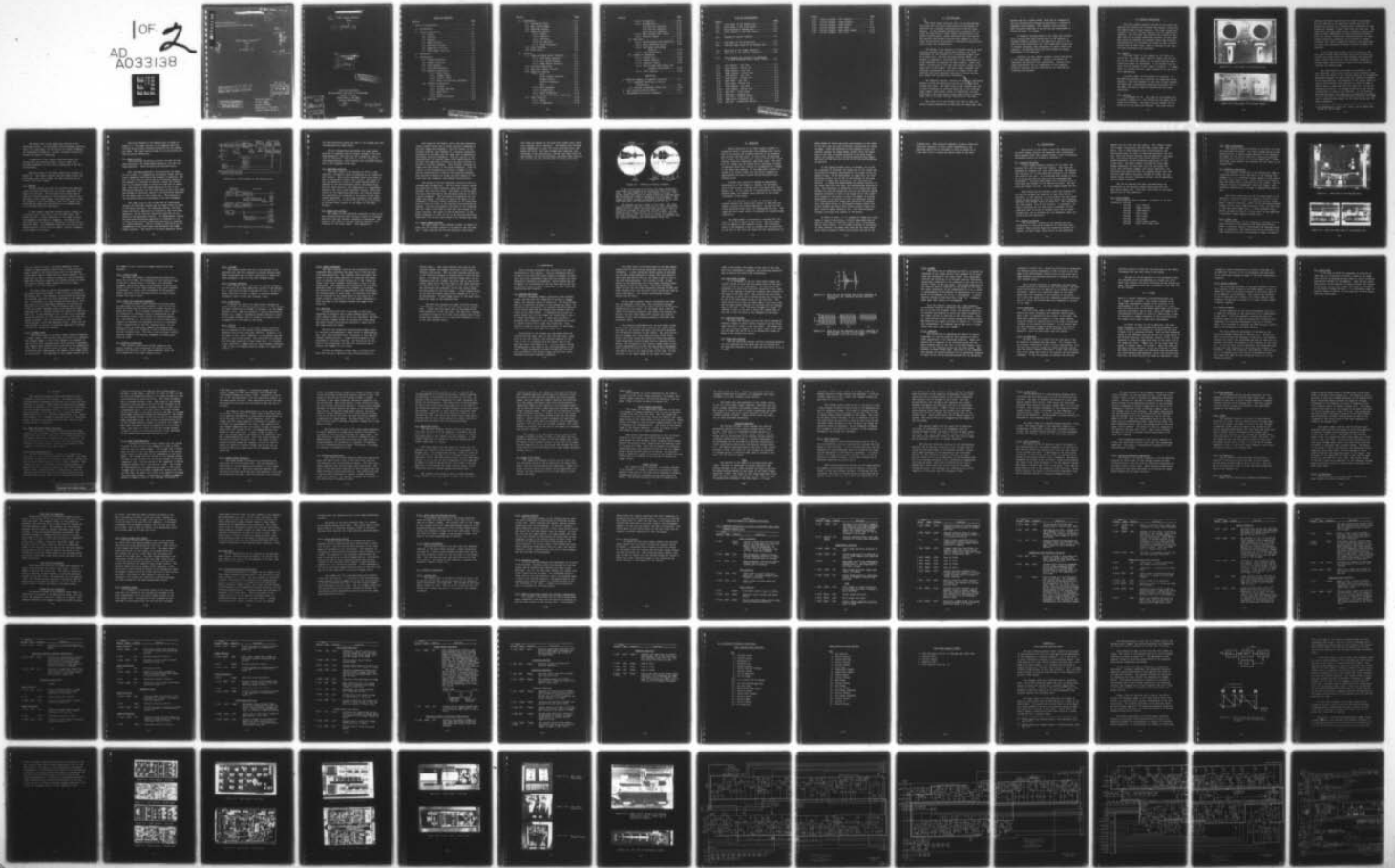

~~SECRET~~ MOST Project -3 FG.

(1)

ADA 033138

Acoustics Laboratory ✓
Massachusetts Institute of Technology

Good

Sonar Signal Analyzer ✓
Q-4X
by
G. Farrell, Jr.

689C
689C1 *eng*
ac
24
67

file: MIT
under contractor's

COPY AVAILABLE TO DDC DOES NOT
PERMIT FULLY LEGIBLE PRODUCTION

DDC
RECEIVED
NOV 26 1978
A

DISTRIBUTION STATEMENT A
Approved for public release;
Distribution Unlimited

Technical Report
1 April 1958
Bureau of Ships
Department of the Navy
Contract NObsr-64653 ✓

SP-2

[REDACTED]

6 Sonar Signal Analyzer
Q-4X.

by
10 G. Farrell, Jr

9 Technical Report.

11 1 Apr 1958

12 100p.

DISTRIBUTION STATEMENT A
Approved for public release;
Distribution Unlimited

Acoustics Laboratory
Massachusetts Institute of Technology
Bureau of Ships
Department of the Navy
Contract NObsr-64653

15

002700
9B

1.

ACCESSION NO.	
NTIS	White Section <input checked="" type="checkbox"/>
DTIC	SCIF Section <input type="checkbox"/>
UNCLASSIFIED	<input type="checkbox"/>
JUSTIFICATION	<i>Not on file</i>
BY	
DISTRIBUTION/AVAILABILITY CODES	
Dist.	AVAIL. AND/OR SPECIAL
A	

Table of Contents

Section	Page
List of Illustrations	vii
1. Introduction	1.1
2. General Description	2.1
2.1 Inputs	2.1
2.2 Controls	2.1
2.3 Displays	2.4
2.4 Range Circuits	2.5
2.5 Amplitude Circuits	2.7
2.6 Range-rate Circuits	2.7
2.7 Power Supply Circuits	2.8
3. Operation	3.1
4. Installation	4.1
4.1 Analyzer Mounting	4.1
4.2 Chassis Locations	4.1
4.3 Parts Numbers	4.2
4.4 Power Requirements	4.3
4.5 External Connections	4.3
4.5.1 Sonar Input	4.3
4.5.2 Trigger Input	4.5
4.5.3 Carrier Input	4.6
4.5.4 Power for Auxiliary Equipment	4.6
4.6 Internal Connections	4.6
4.6.1 Grounds	4.7
4.6.2 Voltage Reference	4.7
4.6.3 ACIM Input	4.7
4.6.4 Filter	4.7
4.6.5 Sweep Condensers	4.8
4.7 Test Unit	4.8



Section	Page
5. Adjustments	5.1
5.1 Cathode Ray Tubes	5.1
5.2 Fast Sweep Trigger.	5.3
5.3 Amplitude Display	5.3
5.4 Range-rate Display.	5.3
5.4.1 Ringer	5.5
5.4.2 Sawtooth	5.5
5.4.3 ACIM Zero.	5.6
5.4.4 DC Amplifier	5.6
5.4.5 Gated Integrator	5.8
5.5 Final Trimming.	5.8
5.6 Field Check	5.9
6. Circuits	6.1
6.1 Sweep and Range Marker Generator.	6.1
6.1.1 Slow Sweep Generator	6.1
6.1.2 Fast Sweep Generator	6.2
6.1.3 Range Marker Generator	6.3
6.2 Deflection Amplifiers	6.4
6.3 Amplitude Display Circuits.	6.5
6.4 Range-rate Display.	6.6
6.4.1 ACIM	6.7
First Clipper Amplifier.	6.7
Ringer Circuit	6.7
Sawtooth Generator	6.8
Gate	6.8
6.4.2 Zero Reference	6.9
6.4.3 DC Amplifier	6.11
6.4.4 Gated Integrator	6.11
6.4.5 Vertical Deflection Amplifiers	6.12
6.5 Power Supplies.	6.13
6.5.1 Input.	6.13
6.5.2 AC Regulator	6.13

Section	Page
6.5.3 DC Supplies	6.13
6.5.4 DC Regulators	6.14
Plus 250-volt Regulator	6.15
Plus 160-volt Regulator	6.15
Minus 250-volt Regulator	6.15
6.5.5 High Voltage Power Supply	6.16
6.5.6 Filament Supply	6.16
6.6 Test Unit	6.17
6.6.1 Synchronizing Pulse Generation	6.17
6.6.2 Relay Operating Circuit	6.18
6.6.3 Echo Range Determining Circuits	6.19
6.6.4 Power Requirements	6.19
6.7 Access to Components	6.19
6.7.1 Display Unit	6.19
6.7.2 Chassis Removal	6.20
6.7.3 Extension Cables	6.20
6.7.4 High Voltage Power Supply and Filament Transformers	6.20
6.7.5 Power Supplies	6.21

Appendices

A. Detailed Summary of Component Functions	A.1
A.1 Component Functions in Circuit Sub-sections	A.1
A.2 Listing of External Connections	A.15
B. Axis Crossing Interval Meter	B.1
C. Photographs and Circuit Diagrams	C.1

List of Illustrations

Figure		Page
2-1.	Front panel of the Display Unit.2.2
2-2.	Front panel of the Power Supply.2.2
2-3.	Block diagram of Display Unit.2.6
2-4.	Block diagram of the Power Supply.2.6
3-1.	Drawing of typical displays.3.0
4-1.	Rear panel of the Display Unit4.4
4-2.	Left and right sides of the Display Unit4.4
5-1.	Wave form at the ringer testpoint.5.4
5-2.	Wave form at the sawtooth testpoint.5.4
B-1.	Block diagram and principle of operation of Axis Crossing Interval Meter (ACIM). . .	.B.3
C-1.	Left chassis - top view.C.1
C-2.	Left chassis - bottom viewC.1
C-3.	Right chassis - top view.C.1
C-4.	Right chassis - bottom view.C.1
C-5.	ACIM chassis - top view.C.2
C-6.	ACIM chassis - bottom viewC.2
C-7.	Main frame - top view.C.3
C-8.	Main frame - bottom viewC.3
C-9.	Power supply - top view.C.4
C-10.	Power supply - bottom viewC.4
C-11.	Test Unit - front panel.C.5
C-12.	Test Unit - chassis top.C.5
C-13.	Test Unit - chassis bottomC.5
C-14.	Right side of Analyzer unit.C.6
C-15.	Top view - transformer channelC.6



Figure		Page
C-16.	Circuit diagram - left chassisC.7
C-17.	Circuit diagram - right chassis.C.8
C-18.	Circuit diagram - ACIM chassisC.9
C-19.	Circuit diagram - main frameC.10
C-20.	Circuit diagram - main power supply.C.11
C-21.	Circuit diagram - test unit.C.12

1. Introduction

The Sonar Signal Analyzer, Q4-X, is an experimental instrument for the direct observation and measurement of amplitude and frequency characteristics of active sonar signals. It was designed primarily as a research tool to study the usefulness of these signal characteristics for target classification, target detection, and fire control. The analysis and display circuits were designed to facilitate the practical utilization of information derived from sonar echoes and reverberation.

The design of the Analyzer is centered around an Axis Crossing Interval Meter (ACIM) which permits the rapid measurement of the frequency of a narrow-band signal such as a sonar echo. The Axis Crossing Interval Meter, described in Appendix B, was developed in this Laboratory to study frequency fluctuations in sonar signals. These frequency fluctuations of the echo are directly related to the range rate of the target. The Sonar Signal Analyzer was developed subsequently to provide, in compact form, the ACIM and auxiliary equipment necessary to derive and display range rate and amplitude information.

The Analyzer contains, besides the ACIM, all amplifiers needed to drive the measuring circuits and two dual-beam cathode ray tubes. The upper beam of each cathode ray tube is used to display the envelope amplitude of the incoming sonar signal, with either linear or logarithmic vertical deflection. The lower beam of each tube is used to display range rate as a linear vertical deflection of the beam.

The first of the two cathode ray tubes is used for normal A-scan presentation of amplitude and range rate. The

second tube has a faster sweep which may be triggered at any pre-selected point during the ping cycle to present an expanded A-scan display. The expanded A-scan permits a more detailed inspection of an echo and the measurement of extent-in-range of a target.

To simplify interpretation of the range rate information, circuits have been incorporated in the Analyzer to provide automatic zeroing of the range rate trace; to provide full-scale deflection for three range-rate values; and to provide smoothing (time averaging) to reduce rapid fluctuations. An auxiliary Test Unit is provided for making adjustments of the Analyzer.

Section 2 of this report contains a brief description of the Sonar Signal Analyzer. Section 3 describes its operation, and Section 4 its installation. Section 5 provides instructions for all adjustments of the Analyzer. Section 6 contains circuit descriptions for checking and servicing the Analyzer.

2. General description

The Sonar Signal Analyzer consists of two units. The Display Unit contains the analysis and display circuits and two high-voltage DC power supplies. The Power Supply unit contains an AC line voltage regulator and two regulated DC supplies. The two units are connected by a cable so that they need not be placed immediately adjacent to each other. Both units are designed for standard relay rack mounting. The Display Unit is provided with slides so that it may be pulled from its dust cover, which is mounted on the rack, for easy maintenance and adjustment.

2.1 Inputs

The power input to the Analyzer is 117 volts, 60 cycles AC. The sonar input should be taken from the output of the audio scan switch of the sonar receiver where a continuous signal is obtainable. It is assumed that the audio will be trained on the target of interest. A trigger input is required from the sonar transmitter at the end of the outgoing ping.

A carrier input to the Analyzer is optional: it provides one possible zero reference for range-rate determination. When the Analyzer is used with a sonar transmitter which has a continuously-operating oscillator (as in the QHB), the carrier input is derived from the sonar oscillator.

2.2 Controls

A photograph of the front panel of the Display Unit is shown in Figure 2-1. The controls on the panel are divided into sections. The upper section contains the two controls for the amplitude displays. The lower section

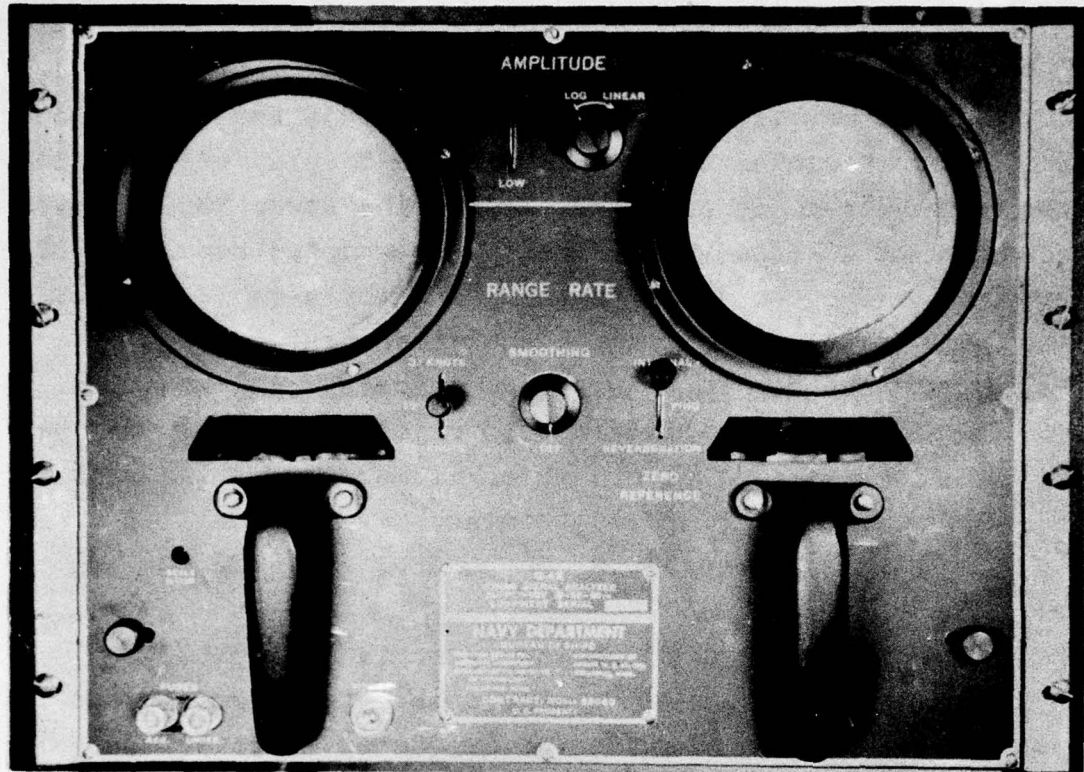

Figure 2-1. Front panel of the Display Unit.

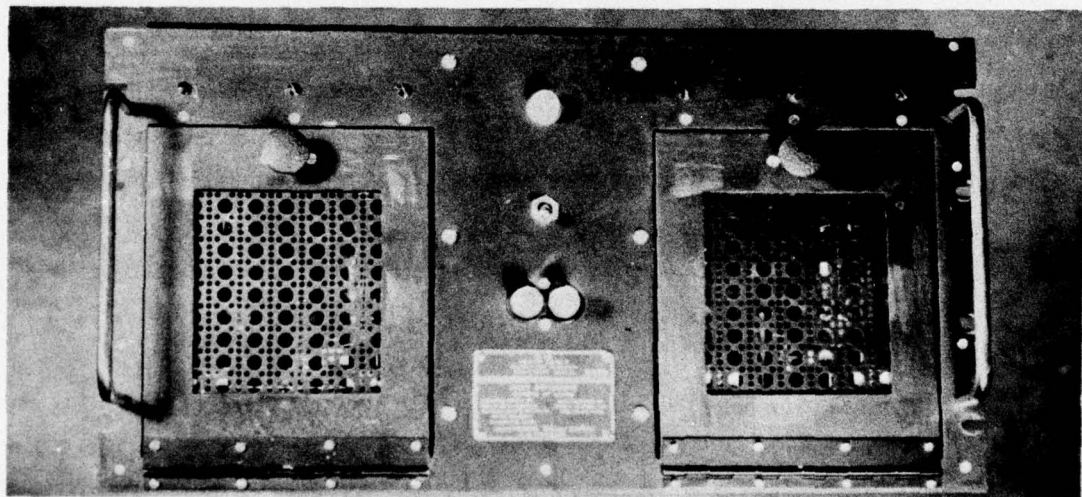

Figure 2-2. Front panel of the Power Supply.

contains the three controls for the range-rate displays. The left* switch in the amplitude control section, the sensitivity control, is a three-position attenuator to compensate for changes of input level from the sonar set. The right knob, the Log-Linear control, operates a switch that selects either logarithmic or linear amplitude displays. With this control turned fully counterclockwise, the logarithmic display is presented; as the control is turned clockwise, the switch changes the display from logarithmic to linear, and continued clockwise rotation increases the amplitude.

In the range rate section, the left switch is the Full Scale control which provides full-scale vertical deflection for range rates of three, fifteen, and forty-five knots. Deflection above the zero reference indicates a closing range, while deflection below the zero reference indicates an opening range.

The right switch in the range rate section is the Zero Reference control which selects a zero reference standard. With the switch in the Internal position, an internally-generated frequency is used as the zero reference standard. In the Ping position, the frequency of the carrier input is used as the reference; this position is used only when a carrier input is available from the sonar set. In the Reverberation position, the average frequency of the initial reverberation is used as the reference. In the Internal and Ping positions, the range rate is measured with respect to one's own ship; in the Reverberation position, the range rate is measured with respect to the ocean medium near the sonar transducer.

* All references to "left" and "right" are as viewed when facing the front panel.

The center knob in the range-rate section is the Smoothing control. In the extreme counterclockwise position, there is no smoothing. As the control is turned clockwise, the smoothing is turned on. Further clockwise rotation increases the amount of smoothing.

In addition to the controls described above, the Display Unit also contains fuses, a pilot light, and a recessed adjustment for the scale illumination of the two oscilloscopes.

The front panel of the Power Supply Unit is shown in Figure 2-2. This panel contains the main power switch, the main fuses, and a pilot light. No other controls are included in the Power Supply.

2.3 Displays

The two cathode ray tubes are provided with engraved scales to permit calibration of the range, amplitude, and range rate displays. The left-hand oscilloscope tube is used for A-scan presentation: the horizontal sweep is proportional to the target range. The right-hand tube is used for expanded A-scan presentation: this tube displays the amplitude and range-rate information on an expanded range scale for more detailed observation.

A range marker, generated electronically, appears as a vertical line on the face of the left-hand tube. The marker provides a visual indication of the range at which the expanded A-scan sweep is triggered. The position of the range marker is adjusted by thumbwheels located directly under the tubes. The thumbwheel under the left tube is the coarse position control for this marker, and the thumbwheel on the right is a vernier.

The block diagram of the Display Unit is shown in Figure 2-3. The upper section of the diagram shows the circuits which provide vertical deflection for the cathode ray tubes. The lower section shows the circuits which provide horizontal deflection.

2.4 Range circuits

The horizontal deflection circuits include the slow-sweep generator, the range-marker generator, and the fast-sweep generator. These circuits are described below.

The slow-sweep generator, which provides the sweep for the A-scan, is triggered by an external signal from the sonar transmitter with which the Analyzer is operated. The rate of this sweep is controlled by an external capacitor. The capacitor is selected to provide a sweep time equivalent to the maximum range at which the sonar set is operating. The output of this sweep generator is fed to the deflection amplifiers for the lower trace on the A-scan tube, and through an electronic switch to the deflection amplifier for the upper trace on the A-scan tube. The operation of the electronic switch is described in the next paragraph.

The upper trace on the A-scan tube is time-shared between the amplitude display and the range marker by means of electronic switches. For amplitude display, the horizontal deflection amplifier is connected to the slow sweep generator, and the vertical deflection amplifier is connected to the amplitude circuits. For range-marker display, the horizontal deflection amplifier is connected to a DC voltage and the vertical deflection amplifier is connected to a pulse generator. The DC voltage is controlled by the thumbwheels on the front panel and determines the range marker position. The output of the pulse generator drives

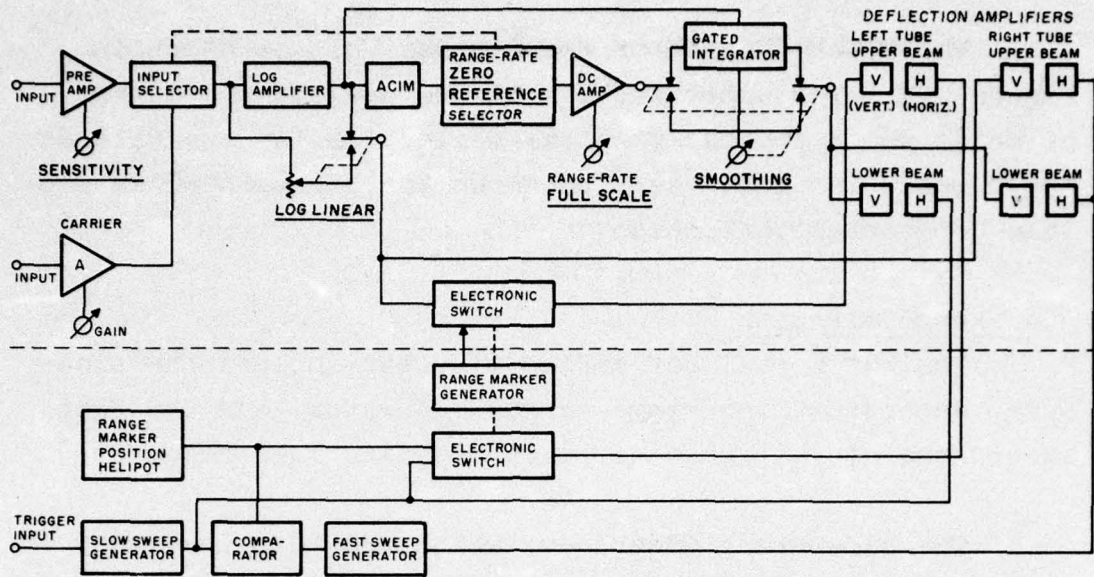

Figure 2-3. Block diagram of the Display Unit.

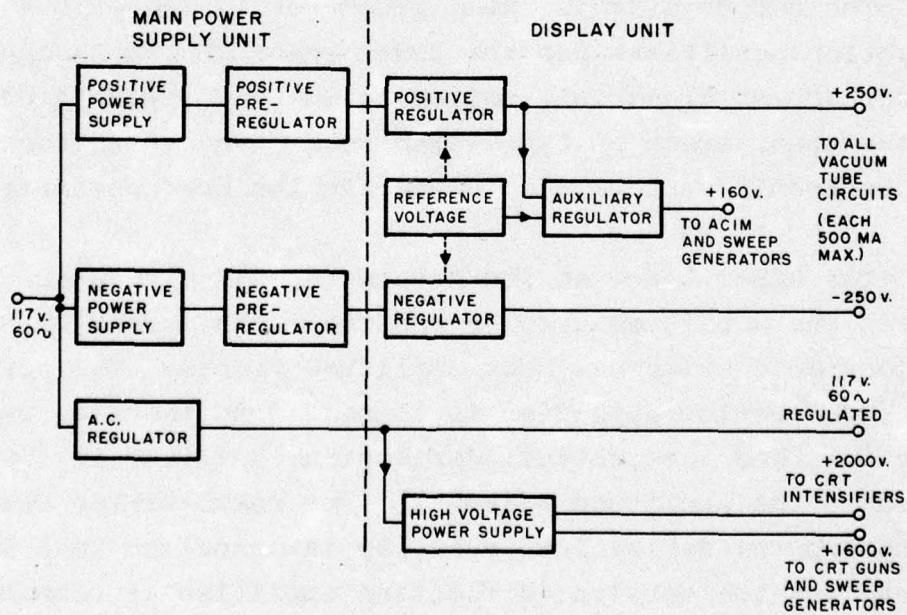

Figure 2-4. Block diagram of the Power Supply.

the beam vertically across the face of the cathode ray tube and generates the range marker.

The DC voltage which determines the range marker position is compared with the output voltage of the slow sweep generator, and, when the two voltages are equal, a pulse is generated. This pulse is used to trigger the fast-sweep generator, which produces the horizontal deflection of the expanded A-scan tube.

2.5 Amplitude circuits

The sonar input to the Analyzer is fed to a pre-amplifier, the gain of which is adjusted by the "sensitivity" control. This control provides three 20-db steps of gain to accommodate varying input levels. The output of this pre-amplifier is fed to an input selector which is operated by the Zero Reference control described below. From the input selector, the signal goes to a logarithmic amplifier and also to the Log-Linear control. With this control in the logarithmic position, the vertical deflection amplifiers are connected to the output of the logarithmic amplifier. In the linear position, these deflection amplifiers are connected through the gain adjustment on the Log-Linear control to the output of the input selector.

2.6 Range rate circuits

The output of the logarithmic amplifier is fed to the Axis Crossing Interval Meter circuits, where the frequency deviation from the reference standard is determined. The output of the ACIM is a voltage linearly related to the frequency of the sonar signal. (See Appendix B.)

The output of the ACIM is fed to the Zero Reference control which selects one of three reference standards as the zero range rate frequency. With the control in the Internal position, the standard is a frequency generated internally in the ACIM, and the range rate is measured as deviations from this frequency. With the control in the Ping position, the carrier signal after amplification is fed into the range-rate circuits by the input selector to provide a reference standard. This provides a measure of range rate with respect to the sonar transducer. With the control in the Reverberation position, a sample of the initial reverberation is used as the reference standard. This provides a measure of range rate with respect to the water near the transducer (Own Doppler Nullification).

The output of the Zero Reference control is fed to a variable-gain DC amplifier. The Full Scale control permits the selection of three different range-rate scales: three, fifteen, and forty-five knots. The output of the DC amplifier may, when selected by the Smoothing control, be fed to a gated integrator. This provides RC integration for the range rate signal. The gate is used at the input of the integrator to prevent violent excursions of the ACIM output such as occur at a null in the envelope from effecting the display. This gate disconnects the input to the integrator when the input to the ACIM is less than the average of the sonar envelope. The output of the DC amplifier, or the gated integrator if used, is fed to the vertical deflection amplifiers for the two lower beams of the cathode ray tubes.

2.7 Power supply circuits

The power supply block diagram is shown in Figure 2-4. There are two DC power supplies, one positive and one negative. These supplies and the pre-regulators associated

with them are mounted on the main Power Supply unit, which also contains the AC regulator. The Display Unit contains final regulators for plus 250 volts, plus 160 volts, and minus 250 volts. The high voltage power supplies, also contained in the Display Unit, provide plus 2000 volts for the cathode ray tube intensifiers, and minus 1900 volts for the cathode ray tube cathodes and the sweep generators.

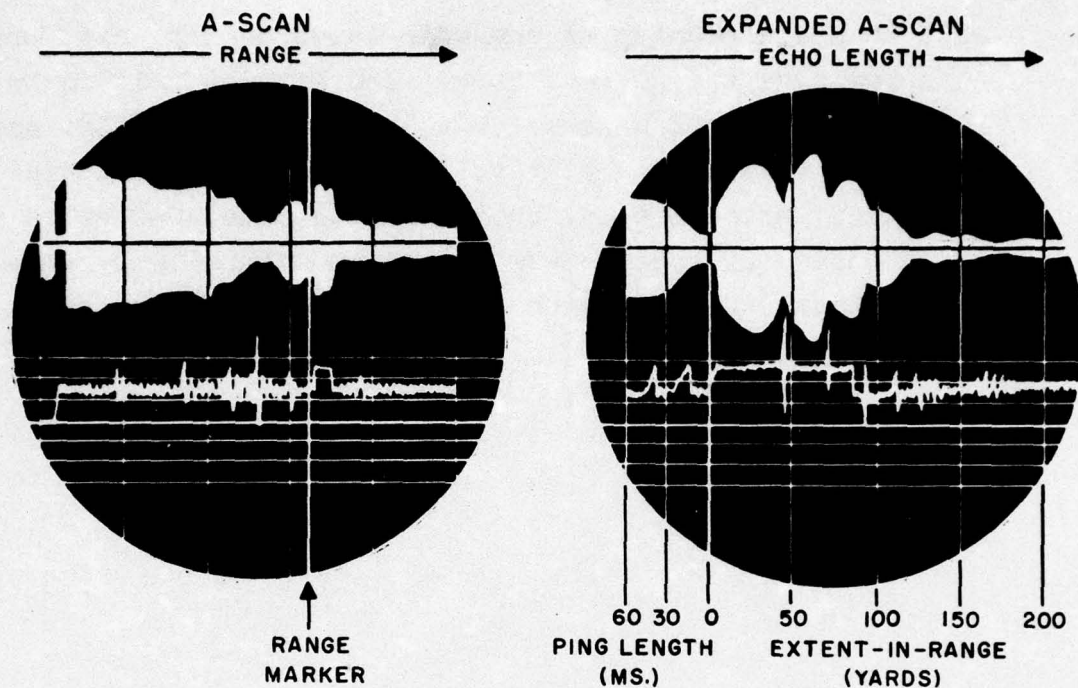

Figure 3-1. Drawing of typical displays.

On the A-scan tube at the left, the upper (amplitude) trace shows the outgoing ping followed by initial reverberation. The range marker is set just ahead of an echo. The bottom (range rate) trace is zeroed during the outgoing ping. The reverberation shows an up-Doppler and the target an additional up-Doppler, clearly indicating a moving target. The range-rate trace becomes increasingly irregular as the amplitude diminishes, and becomes steady during the echo.

The expanded A-scan is shown on the right. The range-rate trace shows that part of the echo is from a stationary target (such as a wake) and permits an accurate estimate of the extent-in-range of the actual (moving) target. If the range-rate Full Scale selector is set on 15 knots, the target range rate is seen to be about 14 knots with respect to the sonar transducer. Own ship's speed may be estimated from the transducer bearing and reverberation range rate.

3. Operation

Typical operation of the Sonar Signal Analyzer in conjunction with a conventional echo-ranging sonar can be used to illustrate the intended function of the displays and controls outlined above. In the course of searching for a target, the operator will normally observe the A-scan display, using the logarithmic amplitude scale. The presence of a target may be deduced from a momentary increase in amplitude which will usually be accompanied by a change in the range-rate display. If the amplitude increase is caused by an actual target, the pip should reappear at approximately the same location during successive echo-ranging cycles.

To assist the operator in making an approximate determination of the range of a target, the horizontal scale of the A-scan is divided into five equal parts (see Figure 3-1). If the sonar set is operating on a 3000-yard maximum range, for example, each division on the A-scan corresponds to 600 yards.

When the presence of a target is suspected, the operator adjusts the sensitivity control to keep the echo signal on scale but suitably magnified. He may find the linear amplitude scale useful in emphasizing the echo. The range-rate Full Scale control is adjusted for maximum usable sensitivity.

The range marker is now moved to coincide with the start of the echo signal on the A-scan. The echo signal will now appear on the expanded A-scan. The horizontal scale of the expanded A-scan is divided into two sections: to the left of the zero line there are two calibrations for

ping lengths of thirty and sixty milliseconds; to the right of the zero line are four fifty-yard calibrations for extent-in-range. With his attention on the expanded A-scan, the operator adjusts the range marker vernier until the beginning of the echo is located properly on the ping length scale; for example, with a thirty-millisecond ping length, the start of the echo will be set at the thirty-millisecond calibration.

If the signal-to-noise ratio is adequate, he is now in a position to determine the range rate of the target and the extent-in-range by observation of the scales on the expanded A-scan. In the measurement of range rate, the Zero Reference control will be set in the Internal or the Ping position if range rates relative to one's own ship are desired. If range-rate measurements are wanted relative to the water near one's own ship, the Reverberation position is used. The difference in deflection of the range-rate trace between the position during the echo and the position during adjacent intervals of time is the range rate of the target with respect to the medium in which the target is moving, independent of the position of the Zero Reference control. If a clearly-observable range-rate indication is present, this indication serves to distinguish between echoes from moving targets and echoes from closely adjacent false targets, such as wakes, knuckles, etc., that have different average velocities with respect to the medium.

If there is difficulty in reading the range-rate trace, owing to rapid fluctuations, a certain improvement may be made by rotating the smoothing control until a reasonably smooth trace results. If too large an amount of smoothing is used, however, the range rate trace may not have sufficient time to reach its final value before the end of the

incoming echo. This should be apparent, however, since the trace will approach its final value exponentially; the smoothing should not be increased to such an extent as to cause this curve to occupy the entire width of the echo.

4. Installation

This section of the report covers the installation of the Sonar Signal Analyzer for operation with conventional echo-ranging sonars that operate between 5 and 25 kilocycles. Adjustment details are treated in Section 5.

4.1 Analyzer mounting

A Sonar Signal Analyzer consists of two units, the Display Unit, and the main Power Supply. Both units are designed for standard 19" relay rack mounting. The Display Unit occupies 14" of rack space and extends 25 1/4" behind the front of the rack. It is provided with slides to allow it to be pulled from its dust cover for adjustment and maintenance. The main Power Supply unit occupies 8 3/4" of rack space and extends 18 3/8" behind the panel. The Display Unit weighs 120 lbs., the Power Supply weighs 135 lbs.

When installing the Analyzer, place the Display Unit so that the cathode ray tubes are at eye level for the operator. If the operator is to be seated, the tube center should be approximately 40" from the floor; for a standing operator, this height should be about 60". The location of the Power Supply unit is not critical. If necessary, the cable connecting the two units may be extended, but consideration must be given to adequate wire size to reduce voltage drop, and to preserve the low impedance output provided by the pre-regulators.

4.2 Chassis locations

The electronic circuits of the Display Unit are constructed on three plug-in chassis to facilitate maintenance. These chassis plug into connectors mounted on a channel, the main frame, which serves as the mechanical

support for the front and rear panels. This channel houses the filament transformers and the high voltage power supplies. Two of these chassis slide in horizontally, one from either side; the third is inserted vertically from the top. The Left chassis contains the pre-amplifier, log amplifier, slow-sweep generator, fast-sweep generator, range-marker generator, and the deflection amplifiers for the A-scan tube. The Right chassis contains the final power supply regulators for plus 250, plus 160, and minus 250 volts, the slow-sweep trigger, the carrier amplifier, and the deflection amplifiers for the expanded A-scan tube. The vertical ACIM chassis contains, besides the ACIM, the log-linear relay, the zero reference circuits, the DC amplifier, and the gated integrator.

The two DC supplies and their pre-regulators are constructed on two separate chassis which plug into the main Power Supply unit. This unit also serves as the mounting for the AC line regulator.

4.3 Parts numbers

Parts numbers, where assigned, correspond to the part location as follows:

100-199	Left chassis
200-299	Right chassis
300-399	ACIM chassis
400-499	Main frame
500-599	Front panel
600-699	Rear panel
700-799	Power supply chassis
800-899	Main Power Supply unit

4.4 Power requirements

The Analyzer requires a source of 110 volts, 60 cycle AC, and draws 1000 watts. The input voltage should be kept above 95 volts to assure proper operation of the Analyzer. The power for the unit is fed into a twistlock connector mounted behind the panel of the Power Supply unit. Above this power input plug is the connector for the cable to the Display Unit.

4.5 External connections

All external connections to the Analyzer are made to connectors mounted on the rear panel of the Display Unit (Figure 4-1), or to terminal strips located on each side of the main frame (Figure 4-2). These strips are accessible when the Display Unit is pulled out on its slides. The two terminal strips are designated "left" and "right," with terminals numbered from 1 through 20 reading from front to rear.

Rear panel connectors include the sonar input to the Analyzer, a three-pin Cannon XL connector, J-603; a five-pin power connector, J-609, for operating external equipment; a twin-ax connector, J-604, for the externally-mounted ringer circuit; and a large connector, J-601, for the cable to the main Power Supply unit. A three-terminal strip, TS-601, permits the use of a filter after the pre-amplifier to provide a higher signal-to-noise ratio.

4.5.1 Sonar input

The sonar input for the Analyzer is obtained from the sonar receiver at the output of the audio scan switch, where a continuous signal, uninterrupted by scanning switching, is obtainable. The sensitivity control provides full-scale deflection without overloading for input voltages of

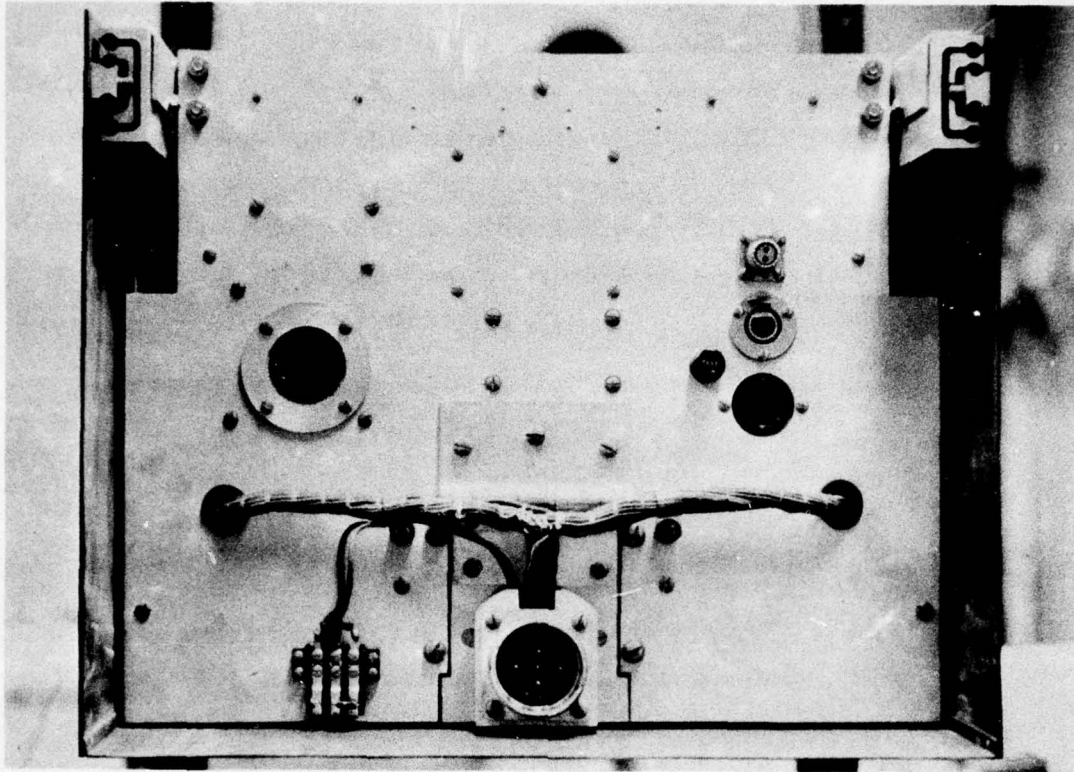

Figure 4-1. Rear panel of the Display Unit.

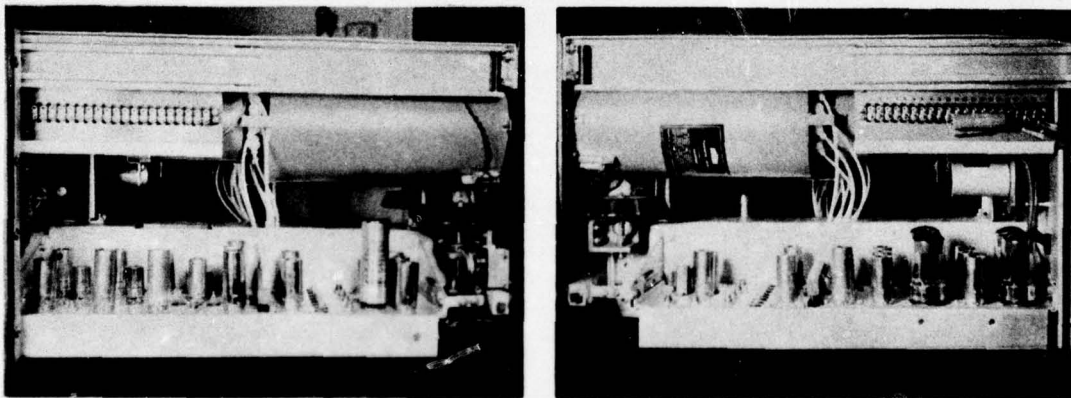

Figure 4-2. Left and right sides of the Display Unit.

0.01, 0.1, and 1.0 volts. The input impedance of the Analyzer is approximately 500,000 ohms, so that the principal loading on the sonar receiver will be the capacity of the cable used to connect the two units together. If a long cable is used, it may be necessary to use an external high-input-impedance amplifier or cathode follower to drive the cable to prevent undue loading and loss of signal strength in the sonar receiver.

The sonar input is fed to the Analyzer on the three-pin Cannon connector (female), J-603, on the rear panel of the Display Unit. The connector is wired with pins one and two grounded, and with pin three connected to the sonar input. On the QHB-A, -C, and -D types of sonar sets, a suitable input for the Sonar Signal Analyzer is available on terminals 4A-18 and 4A-19. These terminals have a relatively low output impedance, and do not require an auxiliary amplifier or cathode follower for cables less than ten feet long. On the AN/SQS-10, 10-A, 11 and 11-A, a suitable output is available on J-401, pin C; pin A on the same connector is ground. This is the output of the audio scan switch and has a very high impedance level. Except for the very shortest of cables, an auxiliary amplifier or cathode follower will always be required.

4.5.2 Trigger input

The A-scan sweep of the Sonar Signal Analyzer requires a trigger signal from the sonar set with which it is operated. This trigger signal is fed to the Analyzer to terminals 17 and 18 on the left terminal strip, with terminal 17 grounded. The trigger, which should occur at the end of the transmitted ping, should be a positive pulse or step. Except for a sharp rise-time on the leading edge, the shape of the trigger pulse is not critical. The amplitude of the trigger should fall in

the range of 5 to 50 volts for proper operation of the Analyzer.

4.5.3 Carrier input

On sonar sets using a continuously-operating oscillator (as in the QHB), the frequency of this oscillator may be used as a carrier input to provide a zero reference standard. The carrier input to the Analyzer is fed to terminals 19 and 20 on the right terminal strip, with terminal 20 grounded. A carrier level adjustment (R-252) permits proper operation of the zeroing circuits for input levels between 0.01 and 10 volts.

4.5.4 Power for auxiliary equipment

A five-pin socket (J-607) mounted on the rear panel provides power for auxiliary equipment. Pin 2 of the connector provides plus 250 volts; pin 3, ground; and pin 4, minus 250 volts. The AC filament connections, pins 1 and 5, are connected to terminals 12 and 13 respectively on the left terminal strip; a fuse (F-601) is connected between pin 1 and terminal 12. To provide 110 volts on these pins, jumpers are required from terminals 12 and 13 to terminals 8 and 9 respectively on the left terminal strip. To provide 6.3 volts on these pins, jumpers are required from terminals 12 and 13 to terminals 10 and 11 respectively on the left terminal strip. The fuse on the rear panel (F-601) prevents damage to the external equipment if wrong connections are made.

4.6 Internal connections

The internal connections include jumpers on the several terminal strips necessary for operation of the Analyzer and selection of the sweep condensers which are to be connected to the right terminal strip.

4.6.1 Grounds

The chassis ground and the circuit ground of the Analyzer have been kept separate to prevent ground loops. These two grounds may be inter-connected by a jumper between terminals 1 and 2 on the left terminal strip.

4.6.2 Voltage reference

The Analyzer may be used with an external reference for the final DC voltage regulators located in the Display Unit. The reference should provide 87 volts. If the internal reference is used, a jumper is required between terminals 3 and 4 on the left terminal strip.

4.6.3 ACIM input

To permit the ACIM to be used without feeding the signal through the amplitude display section of the Analyzer, its input connection is brought to terminal 6 on the right terminal strip. When the Analyzer is used as described in Section 2, a jumper is necessary between terminals 6 and 7 on the right terminal strip to connect the output of the log amplifier to the input of the ACIM.

4.6.4 Filter

A filter, resonant at the sonar carrier frequency, may be connected at the output of the preamplifier on a terminal strip on the rear panel (TS-601). Terminal 1 is the input to the filter, terminal 2 is the ground, and terminal 3 is the filter output. The filter may be obtained from the spare parts kit of most sonar sets. If a filter is not installed, a jumper must be placed between terminals 1 and 3, and a one megohm resistor between the jumper and terminal 2.

4.6.5 Sweep condensers

The right terminal strip has the connections for the condensers which determine the sweep rate of the fast and slow sweep generators. The condenser which determines the speed of the fast sweep generator is connected from terminal 15 to ground; for proper calibration of the "extent-in-range" scale, this condenser should have a value of 0.044 microfarads. The condenser which determines the slow sweep generator speed is connected from terminal 17 to ground, and should have a value of approximately 0.087 microfarads per thousand yards of sonar range. An external relay panel can be connected to the range switch of the sonar set to permit automatic selection of the slow sweep condensers so that the range of the Analyzer matches the range of the sonar set.

4.7 Test Unit

An auxiliary Test Unit is provided to facilitate adjusting the Analyzer and to permit demonstration of Analyzer operation when a sonar set is not available. The Test Unit provides trigger pulses to initiate the A-scan sweep and (with external oscillators) simulates a sonar echo at any range during the sweep.

The Test Unit generates synchronizing trigger pulses at intervals corresponding to range scales of approximately 500, 1000, 3000 and 6000 yards. Provision is also made for external synchronization. A Range Vernier permits a fine adjustment of the pulse interval. For setting up the Analyzer in the laboratory, the Test Unit should be used to provide the trigger for the A-scan.

In order to simulate a sonar echo, a section of the Test Unit operates a Millisec relay (Stevens-Arnold Inc.,

Boston, Mass.). This relay switches the input of the Analyzer between two signals which must be provided by external oscillators. The two fixed contacts and the arm of the relay are brought to binding posts on the Test Unit panel. To simulate an echo with zero range rate, the attenuated output of a single oscillator may be used as the normal input, while the full output of the same oscillator is used as the echo. To simulate an echo with range rate, two oscillators are required, one for the normal signal and the second for the echo signal. A Pulse Length switch on the Test Unit panel selects echo lengths of 6, 30, or 60 milliseconds. An Echo Range control on the panel determines the range of the simulated echo.

The Test Unit receives its power from the five-pin power connector, J-609, on the rear panel of the Display Unit. A short five-pin power cable is provided for the inter-connection of the two units. The Test Unit requires a filament voltage of 6.3 volts; hence, jumpers must be connected from terminals 10 to 12 and from terminals 11 to 13 on the left terminal strip.

5. Adjustments

The following adjustments are required at the time of installation of the Analyzer. Initial adjustments should be made in the laboratory where adequate equipment is available, and final adjustments made when the Analyzer has been permanently installed on shipboard. Before making any adjustments, it is advisable to let the unit warm up for ten or fifteen minutes to permit components to reach operating temperatures and stabilize.

5.1 Cathode ray tubes

With all necessary jumpers installed on the terminal strips, and the Test Unit connected to provide a trigger signal, the Analyzer should be turned on. The first adjustment is to position the beams of the cathode ray tubes. To facilitate this adjustment, the Analyzer should be operated with no sonar input and with relay K-304 removed from its socket on the ACIM chassis. A cliplead must be used to ground either pin 6 of the socket for relay K-304 or pin 7 of V-301B (see Figure C-18). A seven-pin plug with a grounding lead connected to pin 6 may conveniently be used to replace relay K-304 to make this connection. Care should be taken to avoid contact with pin 1 of this plug, since it is at 250 volts when the power is on.

Positioning of the cathode ray tube beams should be started with the upper trace of the left-hand tube. Using R-134 on the left chassis, the vertical position of the trace is set to correspond with the center line of the amplitude scale (see Figure 3-1). R-125 is used to bring the beginning of the sweep to the left-hand marker on the scale. These adjustments can best be made with the Test Unit operating on the 500-yard range and with the corresponding slow-sweep condenser installed.

The lower trace is now positioned in the same manner, using R-148 for the vertical adjustment and R-139 for the horizontal. A lower horizontal width control is provided on the lower sweep amplifier to adjust the total width of this sweep and insure that the two beams cross the face of the tube simultaneously. This control, R-155, is most easily set by displacing one of the beams vertically until the two are close to each other. The lower horizontal width (R-155) and the lower horizontal position (R-139) are then adjusted until the two spots travel across the tube in exact coincidence. The vertical positioning controls should then be reset.

On the right chassis, similar adjustments are made for the expanded A-scan tube. The horizontal position should be adjusted so that the sweep starts at the 60 milli-second mark on the scale. For the upper beam, R-255 adjusts the horizontal position, and R-266, the vertical position. For the lower beam, R-277 adjusts the vertical position; R-267, the horizontal position; and R-279, the horizontal width.

The intensity adjustments for the four beams, R-407, R-413, R-425, and R-432, are located on two panels above the rear of the cathode ray tubes, and should be adjusted for the desired intensity of the traces. The spots should then be brought into focus using controls R-404, R-410, R-423, and R-429, which are located on these same panels. These adjustments should be made with an insulated screwdriver. The intensity of the vertical range marker is adjusted independently by R-178, the intensifier adjustment. This should be adjusted to make the range marker intensity the same as that of the other traces on the tube. If the intensity of the range marker is too high, the retrace

lines of the marker will appear on the face of the tube. With these adjustments completed, the grounding connection may be removed and relay K-304 reinstalled.

5.2 Fast sweep trigger

It is necessary to set the "fast-sweep trigger set finish," R-169, so that the fast sweep starts at the position indicated by the range marker. To facilitate this adjustment, an oscillator should be connected to the sonar input of the Analyzer through the normally open contacts of the relay in the Test Unit. This provides an echo pulse, the position of which can be varied across the A-scan tube by use of the Echo Range control on the Test Unit. The pulse should be set near the right edge of the A-scan tube, and the range marker adjusted to coincide with the leading edge of the echo. The "fast-sweep trigger set finish" adjustment, R-169, is now set to bring the leading edge of the echo to the zero mark on the expanded A-scan scale.

5.3 Amplitude display

The amplitude display circuits may now be checked by feeding a signal of sonar carrier frequency into the sonar input connector, J-603, on the rear panel. The signal fed into this connector appears on the upper trace of the cathode ray tubes and can be set to an appropriate height by means of the sensitivity control.

5.4 Range rate display

With the amplitude display circuits operating properly, the Axis Crossing Interval Meter may now be adjusted for the operating frequency of the sonar set with which it is to be used.

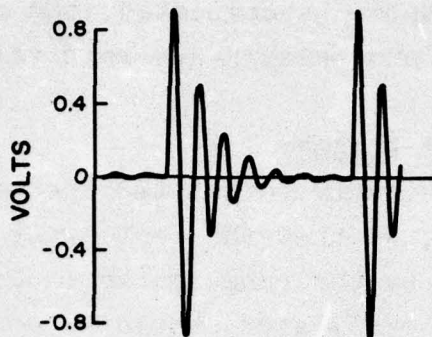

Figure 5-1. Wave form at the Ringer test point (terminal 16, TS-401) when the frequency has been properly adjusted.

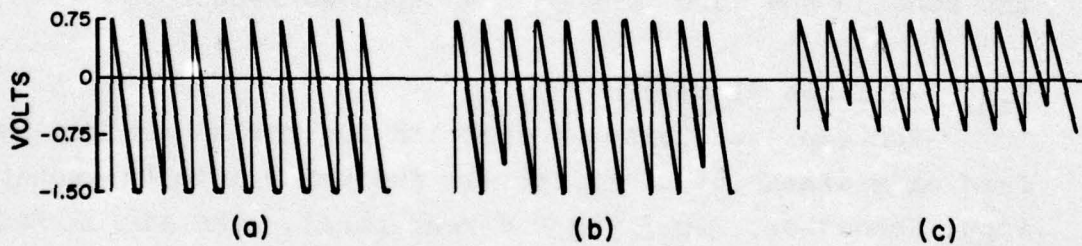

Figure 5-2. Wave form at the Sawtooth test point (terminal 14, TS-401) when: a) R or C is too small, b) R and C are correct, c) R or C is too large.

5.4.1 Ringer

The first step in adjusting the ACIM is to adjust the frequency of the ringer circuit (see Appendix B) to seven times the frequency of the sonar input. This adjustment involves the selection of an external parallel inductance-capacitance combination to be connected to the twin-ax connector, J-604, on the rear panel. The ground connection of the inductor must be connected to the ground in the cable. For sonar frequencies in the neighborhood of 5 kc, a value of approximately 20 millihenrys is appropriate; for 10 kc, about 10 millihenrys; for 25 kc, 5 millihenrys. A toroid inductor should be used which has a high "Q". A General Radio Type 1481 inductor is recommended.

With the inductor connected and a high-frequency oscilloscope (such as a Tektronix 514) connected to terminal 16 on the left terminal strip, the external capacitor is selected and adjusted to yield the proper frequency in the ringer circuit as observed on the oscilloscope. That is, there should be seven cycles during each decay period. The waveform will appear as shown in Figure 5-1. To permit fine adjustments, the condenser may be made up of a fixed silver mica and a small air trimmer.

5.4.2 Sawtooth

The second step in adjusting the ACIM is to select components to form the sawtooth (see Appendix B) with a slope appropriate to the operating frequency. These components are a capacitor to be connected across the two upper binding posts at the rear of the ACIM chassis, and a resistor to be connected across the two lower posts. The resistor is about 50,000 ohms. The value of the condenser lies between 18 micromicrofarads (for an operating frequency of about 25 kc) and 30 micromicrofarads (for an operating

frequency of about 5 kc). During the selection of components, the sawtooth vernier adjustment, R-344, located on the top edge of the ACIM chassis, should be set at mid-scale and a high-frequency oscilloscope connected to terminal 14 of the left terminal strip.

When a proper selection of components has been made, a linear sawtooth is observed on the oscilloscope. The sawtooth should extend as far negative as is possible without bottoming. Figure 5-2-a shows the signal at this point when either the condenser or the resistor is too small; 5-2-b shows the signal with the components properly selected; and 5-2-c shows the waveform when the condenser or resistor is too large.

5.4.3 ACIM zero

With the sonar input to the Analyzer adjusted to exactly the sonar frequency, the sawtooth vernier adjustment, R-344, is adjusted for zero output of the ACIM. The ACIM output appears on terminal 1 of the right terminal strip and should be observed with a zero-center vacuum-tube voltmeter or DC-coupled oscilloscope. If the vernier does not have sufficient range to allow zeroing, the value of the ringer tuning condenser may be adjusted until it is possible to zero the ACIM output with the vernier.

5.4.4 DC amplifier

The next step is to adjust the zero and gain of the DC amplifier following the ACIM output. Set the gain control labeled "ACIM gain" (R-367) to about mid-position, flip the Full Scale switch through its three positions, and adjust the control labeled "ACIM zero," R-365, until the position of the range-rate trace on the cathode ray tube remains unchanged. It may be necessary to readjust the vertical

position controls to make the zero positions of the traces correspond with the zero lines on the scales.

The gain of the DC amplifier is now adjusted so that the frequency shift corresponding to a range rate of 45 knots will produce full-scale deflection on the cathode ray tube. The frequency shift, Δf , is related to the range rate by the formula:

$$\Delta f = 0.69FV_r$$

where F = carrier frequency in kilocycles/second, and V_r = range rate in knots. The overall accuracy of the range-rate measurements depends on the accuracy of the measurements of Δf . An electronic counter, or a precision oscillator such as the General Radio Type 1107-A interpolation oscillator, may be used. Since the range of the interpolation oscillator is from 20 to 5000 cycles, it may be necessary to compare harmonics of this oscillator with the signal source used to make these adjustments.

To adjust the gain of the DC amplifier, the sonar input frequency is first shifted from the frequency of the sonar transmitter by an amount, Δf , as given by the above formula, with V_r equaling 45 knots. With the Zero Reference switch in the Internal position and the Full Scale switch in the 45-knot position, the ACIM gain control, R-367, is then adjusted to bring the range-rate trace to the outer line on the range-rate scale. (Upper line, if the sonar input frequency is raised; lower, if lowered.) Since the ACIM zero and gain controls interact, it will be necessary to repeat the above two steps until the ACIM meets both the gain and zero requirements simultaneously. After both controls have been set, the ACIM circuits are ready for operation. Since

a change in center frequency has no effect on the gain if the ACIM zero (Section 5.4.3) is readjusted, the gain need not be reset when changes are made in the sonar transmitter frequency.

5.4.5 Gated integrator

The remaining adjustment is the gate threshold control. This control, R-389, located on the ACIM chassis, is used to adjust the level of the sonar envelope at which the input to the integrator is disconnected. This control may normally be left in mid-position; however, for certain special measurements, one may wish to adjust it to reject either larger or smaller signals.

5.5 Final trimming

On the completion of the above adjustments, the unit is ready for operation in the laboratory or for installation in the field. Since the automatic zeroing with the Zero Reference switch in the Ping or Reverberation positions will compensate for inaccurate adjustment only over a limited range, it is desirable to readjust the ACIM zeroing to match exactly the frequency of the sonar carrier.

The final ACIM zero adjustment is the same as the initial adjustment described in Section 5.4.3. Unless the sonar set with which the Analyzer is used has a continuously-running oscillator, this adjustment may best be made with an external oscillator set exactly to the frequency of the sonar set. If an oscillator is not available, this adjustment may be made when the transducer is stationary with respect to the water. Under this condition, the ACIM zero (see Section 5.4.3) is adjusted until the initial reverberation shows zero range rate when the Zero Reference control is in the Internal position.

5.6 Field check

If the ship on which the equipment is installed is under way, it is possible to obtain a check on the range rate circuits by pinging directly ahead or astern (relative bearing zero degrees or 180 degrees). With the Zero Reference control in the Internal or Ping positions, the initial reverberation should show a range rate equal to the speed of the vessel through the water. If a stationary target is directly ahead or astern, its echo may also be used to perform this field check.

6. Circuits

This section contains detailed descriptions of the electronic circuits of the Analyzer. The amount of detail included varies, depending upon whether the circuits are conventional or unusual. These circuit descriptions are supplemented by an appendix (A.1) listing the function of each vacuum tube and each adjustable control. The circuit descriptions are given in five sections: 6.1. Sweep and Range Marker Generator; 6.2. Deflection Amplifiers; 6.3. Amplitude Display; 6.4. Range-rate Display; and 6.5. Power Supplies. Section 6.6 describes the Test Unit, while 6.7 describes access to components.

6.1 Sweep and range marker generator

This section of the Analyzer includes the slow sweep generator and its trigger, the fast sweep generator, and the range marker generator. The circuits for these sections of the Analyzer are shown in Figures C-16, C-17, and C-19. It should be noted that not all portions of this circuit are mounted on the same chassis; however, the location of each component is indicated by its part number.

6.1.1 Slow sweep generator

The slow sweep generator receives its trigger from the sonar set with which the Analyzer is operated. The trigger enters the Analyzer on terminal strip TS-401, terminal 18, and is capacitively coupled to V-214, a 2D21 thyratron. This thyratron is used to discharge the slow sweep generator capacitor, which is externally mounted on the right terminal strip, TS-402, between terminal 17 and ground. After the 2D21 has ceased conducting, the slow sweep capacitor is recharged from a current source, which consists of R-417 and

R-418 in series with the negative high-voltage supply, to provide a linear sweep. One-half of a 6AL5 (V-106A) is used to limit the maximum excursion of the sweep voltage in a negative direction to about 200 volts. This sweep voltage is fed to cathode follower V-107A. The output of the cathode follower V-107A provides a DC bias for the filament of the 2D21 to keep the heater-to-cathode voltage of this tube at a reasonable value. It is also fed to a voltage divider (R-247 and R-282) in the grid circuit of the 2D21 to increase the trigger sensitivity during the sweep period. The output of the cathode follower V-107A is also fed to the horizontal width adjustment R-155. The output of potentiometer R-155 is fed through cathode follower V-111B (half of a 12BH7) to the lower horizontal deflection amplifier for the A-scan tube. The output of V-107A is also fed through cathode follower V-112A to an electronic switch, V-113, described in the range marker generator section (6.1.3).

6.1.2 Fast sweep generator

A portion of the slow sweep voltage from the cathode follower V-107A is fed to the comparator V-108A (a 6AL5) used for the fast sweep trigger. The voltage used to determine the start of the fast sweep is provided in the helipot R-527, which is controlled by the thumbwheels on the front panel. The voltage from the helipot is fed through cathode follower V-112B (a 12AT7) to the second cathode of the 6AL5 comparator tube. The two plates of the comparator V-108 are connected together and to the grid of V-109A. The voltage on these plates will be approximately equal to the helipot voltage until the slow sweep voltage has reached this level. At this time, the plates will start to go negative following the slow sweep voltage. V-109 acts as a Schmidt trigger to produce a negative pulse at the time when the plates of

V-108 start to go negative. A reference voltage for the Schmidt trigger is taken from helipot R-527 through the "fast-sweep-trigger-set-finish" R-169. Adjustment R-169 is used to set the beginning of the fast sweep with respect to the range marker position. This adjustment effects the fast sweep position only when the slow sweep is near the end of its path.

The negative pulse generated in V-109 is used to cut off V-107B. As the plate of V-107B rises, an NE2 neon bulb, I-109, ignites and generates a sharp positive pulse which is fed to the grid of V-110, a 2D21 thyratron. This tube charges the fast sweep capacitor (connected to terminal 15 on TS-402) to approximately 160 volts. This capacitor is then charged negatively from its initial voltage of approximately 160 volts through R-416, a 50-megohm resistor connected to minus 1900 volts. A 6AL5, V-106B, is used to limit the maximum negative excursion of this capacitor voltage to approximately 80 volts. This fast sweep voltage is then fed to cathode follower V-111A. The output of this cathode follower biases the filament of V-110 in order to reduce its heater-to-cathode voltage, and drives the two horizontal deflection amplifiers for the expanded A-scan tube V-401.

6.1.3 Range marker generator

The range marker is produced by time-sharing the upper trace of the slow-sweep tube. The time-sharing is controlled by a free-running multi-vibrator, V-114, operating at about one kc. This multi-vibrator operates two electronic switches and drives the pulse generator V-117 and the intensifier circuits. The first switch, V-113, selects

either the range-marker voltage from cathode follower V-112B or the slow-sweep voltage from cathode follower V-112A. The output of this switch is fed through V-116B, a cathode follower, to the upper horizontal deflection amplifier for the A-scan tube. The second switch, V-115, selects an input for the vertical deflection amplifier. During normal display periods, the switch selects the output of the amplitude display circuit; during the range marker period, the switch selects a pulse, generated by V-117, which drives the beam first to the top of the tube, and then vertically downward to generate the range marker. The neon bulbs I-110, I-111, and I-112 are used to provide a constant voltage drop to the grid of V-115A.

The intensifier section of the range marker generator is used to generate a voltage which controls the relative intensity of the beam when producing the range marker. During the period of switching, the beam is blanked out by a negative pulse. During the period when the range marker is being displayed, the intensity is increased to compensate for the increased deflection speed. The amount of increase in intensity is adjusted by R-178.

6.2 Deflection amplifiers

Since there are eight identical deflection amplifiers which use tubes V-104, V-105, V-216, and V-217, only one such amplifier will be described in detail. The lower horizontal amplifier for the slow sweep uses tube V-105A. The input to this deflection amplifier is fed through R-139, the lower horizontal positioning control. Neon bulbs I-105 and I-106 are used to maintain a constant voltage difference across this control. This permits changing the position of the trace without varying its width.

The potentiometer, R-139, is used to vary the DC voltage applied to the deflection plates, thereby shifting the position of the display on the screen of the tube. Capacitor C-122 is used to compensate for high frequency loss across the potentiometer. The output from the potentiometer is fed to one of the deflection plates and to the grid of the deflection amplifier, V-105A, through a ten-to-one dividing network. The plate of this deflection amplifier feeds the inverted signal to the other deflection plate in the cathode ray tube. The ten-to-one divider and V-105A have an over-all gain of about unity and act as a phase inverter to provide push-pull drive for the deflection plates.

6.3 Amplitude display

The amplitude display circuits receive an input from the sonar set with which the Analyzer is operated, and amplify the signal to a level sufficient to drive the deflection amplifiers of the cathode ray tube displays. A logarithmic amplifier is included so that the display may be either logarithmic or linear.

The input signal from the sonar set is fed into the Analyzer on connector J-603 mounted on the rear panel of the Display Unit. This signal goes through a cable to P-401 and J-101 and then to the input of the two-stage feedback pre-amplifier, V-101. The sensitivity control on the front panel selects 1, 10, or 100 for the voltage gain of this amplifier by means of relays K-102 and K-103. The output of the pre-amplifier is fed through the input selector relay, K-101, associated with the zeroing circuit described later.

The output of the relay is fed to a three-terminal strip, TS-601, on the rear panel to permit the insertion of

a filter if desired. The output of this filter drives another feedback amplifier consisting of V-102B and V-103B. The output of this amplifier provides the linear display signal, and also feeds the Logaten (Kalbfell Laboratories, Inc., San Diego, California, type 511C) which produces a logarithmic signal at the input to a third feedback amplifier (V-102A and V-103A), which amplifier provides the logarithmic display signal. The output of this amplifier is fed to the log-linear selector, relay K-301, while the linear signal is fed to this relay through R-524, the Log-Linear Control. Switch S-522 is used to operate the log-linear selector relay, K-301, which is normally in the logarithmic position. As this control is rotated clockwise, the linear display is selected, and the size of the signal is increased with further rotation.

The output of the log-linear selector relay is fed through a cathode follower, V-301A, to the upper vertical deflection amplifier, V-216B, of the fast sweep tube, V-401. The output of the cathode follower is also fed to the upper vertical amplifier for the slow sweep tube through the electronic switch, V-115 (described in the range marker generator section, 6.1.3).

6.4 Range rate display

The range rate display circuits are the ACIM, the zero reference selector, the DC amplifier, the gated integrator, and the vertical deflection amplifiers. These circuits, which are fed by the output of the logarithmic amplifier, provide deflection for the lower traces on both cathode ray tubes.

6.4.1 ACIM

For purposes of circuit description, the ACIM is divided into the first clipper amplifier, the ringer, the second clipper amplifier, the sawtooth generator, and the gate. These circuits are shown in Figure C-18.

First clipper amplifier

The output of the logarithmic amplifier is fed into four stages of clipper amplifiers that are used to generate a square wave with fast rise time. The four stages use both halves of V-302 and V-303, which are 6BQ7A's; the clipping is done by the 1N34A diodes in the grid circuits. These diodes are biased at plus and minus (approximately) one volt to establish the clipping levels. The output of the fourth stage of the clipper amplifier V-303A is coupled to the next stage by means of a pulse transformer.

This pulse transformer saturates so that its output consists of two pulses, one positive and one negative. These pulses are fed through a diode clipping circuit which removes the positive pulse, leaving only the negative pulse at the grid of V-304A. This tube is biased to a normally-conducting state; the sharp pulse cuts the tube off, generating a sharp positive pulse at the plate. The positive pulse is directly coupled to the grid of the cathode follower V-304B, which is normally cut off and which excites the ringer circuit.

Ringer circuit

The ringer circuit, a parallel LC network connected to the cathode of V-304B, is pulsed by the positive spike applied to the grid of this tube and is adjusted to produce a damped sine wave at a multiple of the sonar input frequency. The multiple normally selected for operation in

the ACIM circuit is seven. Resistors R-319 and R-321 are a voltage divider used to provide a low impedance test output (terminal 16 of left terminal strip, TS-401).

The damped sine wave generated in the ringer circuit is fed to a four-stage clipper amplifier, identical with the first clipper amplifier, consisting of tubes V-305 and V-306. The output of V-306A is fed to a pulse transformer and pulse-clipping network, and into a pulse amplifier (V-307A) and cathode follower (V-307B). These circuits then are identical to those described previously.

Sawtooth generator

The cathode follower, V-307, charges the sawtooth-generating capacitor which connects between point A and ground. This capacitor discharges through one-half of a 5751, V-319A, which is a constant current source. The discharge rate is controllable by an external cathode resistor connected between points B and C. A vernier adjustment of the discharge rate is provided by a 5000-ohm potentiometer, R-344, connected in series with the external cathode resistor. The sawtooth thus generated is fed into a dual cathode follower, V-308. The output of this follower is connected to voltage divider, R-348, and R-349, used to provide a test point for the sawtooth signal.

Gate

The sawtooth is the input to a bi-directional gate, V-309. The gate is controlled by a pulse amplifier and cathode follower, V-311, which receives its input pulse from the pulse-forming network at the output of the first clipper amplifier, V-303B. The output of this pulse amplifier, V-311, opens the gate to sample the sawtooth at the time of a negative-going zero crossing of the sonar input. A 47 μf

capacitor, C-318, at the output of the gate, holds the sampled sawtooth voltage between gate openings. A 7-45 μf trimmer capacitor, C-316, cancels any leakage through the gate when it is shut off.

The voltage across C-318 is fed to the grid of V-310, a dual cathode follower, which provides a low impedance signal for subsequent stages. The output of cathode follower V-310 is used to bias the heaters of the gate tube in order to reduce heater cathode leakage in this stage. The output of the dual cathode follower, V-310, is referred to as the raw ACIM output and will have a value of zero volts DC when the sonar input frequency is that for which the ringer and sawtooth values are adjusted. As the frequency increases, the voltage at this point will increase; as the frequency decreases, the voltage will decrease.

6.4.2 Zero reference

The output of the cathode follower V-310 is fed to the Zero Reference selector circuits which provide the three means of zero reference. In the Internal position, the zero reference is solely dependent upon the tuning of the ringer and the adjustment of the sawtooth components. In this position, the signal from cathode follower V-310 is fed directly to a cathode follower, V-312A, which drives the DC amplifier described in Section 6.4.3.

With the Zero Reference selector in the Ping position, the signal is fed through a series RC network, C-321 and R-360, to this same cathode follower. To provide the zero reference, the output of the RC network is grounded and the carrier input is fed into the ACIM at the beginning of the

slow sweep by the input selector relay. During this period, when the output of the capacitor is grounded, the raw ACIM output will be a voltage related to the carrier frequency. The capacitor will be charged to this value. With the ground removed, the voltage on the capacitor will remain constant throughout the ping cycle and will be subtracted from the raw ACIM output. A 5963, V-318, is a mono-stable multi-vibrator which operates the relays K-101 and K-302. Relay K-101 shifts the signal from the normal input to the carrier input. Relay K-302 shorts the RC network output to ground. This multi-vibrator is triggered by the flyback of the slow sweep.

The carrier signal from the sonar set is amplified in V-215B, is transformed to a low impedance level by cathode follower V-215A, and then is fed to the input selector relay. The carrier gain control, R-252, is provided in the input of the amplifier V-215B so that the carrier signal may be adjusted to a level for proper operation.

With the Zero Reference selector in the Reverberation position, the RC network (R-260 and C-321) is again used to couple the raw ACIM output to the cathode follower, V-312A, and is again grounded at the beginning of the slow sweep period. In this reference position, however, the input selector relay, K-101, is not operated, so the reference signal is the average frequency of the reverberation immediately following the ping. Since this reverberation will have a Doppler shift associated with the velocity of the vessel through the water, the resultant zero reference will be the range rate of the water near the transducer (ODN).

6.4.3 DC amplifier

The DC amplifier is a variable-gain feedback amplifier which has sufficient gain to drive the deflection amplifiers. The gain is adjusted discreetly by a front panel switch labeled "Full Scale." This switch has three gain positions which provide full-scale range rates of 3, 15, and 45 knots. For accurate adjustment of the range-rate scales, a gain control, R-367, is provided for this amplifier. A zeroing control, R-365, is used to compensate for any DC drift in the amplifier. The adjustment of these controls is described in the preceding section.

The input stage is a cathode-coupled amplifier, V-313, a 6072. The output stages of the amplifier consist of a conventional DC amplifier, V-314A, and a cathode follower, V-314B. The cathode follower provides low output impedance to drive the feedback network and the following circuits.

6.4.4 Gated integrator

The output of the DC amplifier may be fed either to the smoothing section (the gated integrator) or directly to the vertical deflection amplifiers for the two lower traces of the cathode ray tubes. If smoothing of the ACIM output is desired, a front panel switch, S-521, is operated by rotating the smoothing control, R-523, clockwise. The switch energizes two relays, K-303 and K-304. Relay K-303 connects the input of the gated integrator to the DC amplifier output. The output of relay K-303 is fed to the gate, V-315, and the gate output is fed to the integrator R-523 and C-330. Relay K-304 transfers the input of the deflection amplifiers from the DC amplifier output to the gated integrator output.

The gate portion of the integrator consists of a gate, V-315 (a 12AU7), and its driving circuits, V-316 and V-317. A 6AL5, V-316, is used to rectify the logarithmic amplifier output. Section A of the 6AL5 is used to provide a signal which follows the instantaneous variations in the envelope. Section B generates a similar signal which is fed to an RC integrator, R-384 and C-329, to produce a signal equal to the average value of the envelope. The signal representing the instantaneous value of the envelope and that representing the average value of the envelope are fed to the two grids of V-317. When the instantaneous value of the sonar input falls a predetermined amount (selected by R-389, the gate threshold control) below the average value of the envelope, V-317A conducts. The plate of V-317A is connected to the grids of the gate tube, V-315. When V-317A conducts, the gate is cut off to prevent violent excursions of the range rate display.

The integrating portion of the circuit consists of R-523, the front panel control, and C-330, the integrating capacitor. The amount of smoothing is increased by clockwise rotation of R-523.

6.4.5 Vertical deflection amplifiers

The output of the gated integrator or the DC amplifier, selected by relay K-304, is fed through cathode follower V-301B directly to the two vertical deflection amplifiers for the lower traces on each tube. These deflection amplifiers are identical with those described in the section on range marker generation and sweep circuits.

6.5 Power supplies

The DC power supplies and pre-regulators for the Analyzer are mounted in the Main Power Supply unit. Also mounted in this unit is an AC voltage regulator to supply critical circuits in the Display Unit. The final regulators for the DC voltages are mounted on the right-hand chassis of the Display Unit.

6.5.1 Input

The Analyzer requires a 60-cycle AC power source, nominally 115 volts, and will operate over a voltage range of 95 to 135 volts. The power is fed to the unit through a connector (P-801), shown in Figure C-20, mounted on the rear of the Main Power Supply unit just below the large connector (J-803) used to feed power to the Display Unit. Power from the connector is fed through two ten-amp fuses, F-803 and F-804, to the main switch, S-801. The switch and the fuses are the only front panel controls on this unit. The output of the switch, S-801, is fed to the AC voltage regulator, T-801, to the two DC power supplies, and to non-critical circuits in the Display Unit.

6.5.2 AC regulator

The AC regulator (Raytheon Type VR-6114) has a capacity of 250 watts and will provide 115 volts output over an input voltage range of 95 to 135 volts. The output of the regulator is fed to J-803 and then through the cable to the Display Unit.

6.5.3 DC supplies

There are two identical DC supplies constructed on

plug-in chassis which slide in through doors in the front panel of the Main Power Supply unit. One supply is used to provide the positive voltages necessary in the Display Unit, while the second supply provides the negative voltages. Photographs of the supplies are shown in Figures C-9 and C-10, and the circuit is shown in Figure C-20. The output switch S-801 feeds AC to the primary of the power transformer (T-701) through pins 1 and 2 of P-701. The transformer provides filament and plate voltages for the power supply, and an additional filament winding which is used for the filaments of the series tubes in the final regulator located in the Display Unit.

Each power supply uses two type 83 mercury vapor rectifier tubes with the two plates in each tube connected in parallel through 10-ohm balancing resistors (R-701, R-702, R-703, and R-704). The output of the rectifier tubes is fed to a capacitive input filter made up of C-701, L-701, C-702, and C-705. R-711 and R-712 are used to provide equal voltage drops across C-702 and C-705, which are in series, to increase their voltage ratings. The output of the filter is fed to the plates of two paralleled series regulator tubes (Type 6080), and the cathodes of these tubes provide the pre-regulated output of the supply. The reference of the regulator is V-706, an OB2, and the amplification is provided by V-703, a 6X8. The triode section of the 6X8 is used as an amplifier for the reference voltage, while the pentode section is used to drive the grid of the 6080 series tubes.

6.5.4 DC regulators

The circuits of the DC regulators located on the right chassis are shown in Figure C-17.

Plus 250 volt regulator

The positive output of the positive supply is connected to the plates of the two paralleled 6080 series tubes, V-207 and V-208. The negative output of this supply is grounded. The plus 250 volts is taken from the cathodes of the 6080 regulator tubes. The reference for the positive regulator may be either an internal reference tube, V-206 (a 5651), or may be provided externally if desired. The reference voltage is compared with the output of the 250-volt supply in V-211, a 12AX7, which serves as a comparator stage. The push-pull output from this stage is used to drive V-210 (a 12AX7), a push-pull amplifier stage. The triode section of V-209, a 6U8, is used as an additional stage of amplification for one side of the push-pull signal; the pentode section is used to combine the output of the triode section and the second output of the preceding 12AX7 to provide a push-push output which drives the grids of the 6080 series tubes.

Plus 160 volt regulator

To provide plus 160 volts, an additional regulator is used to drop the plus 250 volts to this value. V-213, a 12BH7, is used as the series tube. The tube is shunted by R-285, a 2000-ohm, 10-watt resistor, to provide additional current at plus 160 volts. The amplifier for this stage is a 6U8. The triode section receives its reference from the same source as the positive regulator, and the pentode section is used to control the grids of the series tubes.

Minus 250 volt regulator

The positive output of the negative power supply is connected to the plates of two 6080 series tubes, V-201 and V-202, the cathodes of which are connected to ground. The negative terminal of the negative supply provides the minus

250 volts. The amplifier which controls the grids of the 6080's is made up of V-203, V-204, and V-205. Except for the source of reference voltage, this amplifier is identical to the one used in the plus 250 volt regulator. To provide a reference for the negative supply, the plus 250 volt supply is used. The voltage is reduced to an appropriate value by a divider made up of R-218 and R-219.

6.5.5 High voltage power supply

The high voltage power supply used for the cathode ray tubes and in the sweep-forming circuits provides plus 2000 volts and minus approximately 1600 volts. The circuits of this supply are shown in Figure C-19. The power transformer and filter for this supply are located within the main channel of the main frame while the rectifiers are located on the rear panel. The high voltage winding of the transformer (T-405) provides 1600 volts RMS. This is fed to two half-wave selenium rectifiers (CR-601 and CR-602) to provide the positive and negative high voltage outputs. The positive output has only a single filter capacitor, C-401, and is fed to the intensifier plates of the cathode ray tubes. The negative supply has an RC filter made up of C-402, R-419, and C-403. The output of this supply is used for the cathodes of the cathode ray tubes and to provide the negative high voltage for the sweep generating circuits.

6.5.6 Filament supply

The filaments of the series tubes in the plus and minus 250 volt regulators are provided by windings on the power transformers on the two power supply chassis in the Power Supply unit. The majority of the filaments in the remainder of the Display Unit are fed from four filament

transformers mounted within the main channel of the Analyzer. The transformers are T-401, T-402, T-403, and T-404. The center taps of T-401 and T-403 are returned to ground and these transformers supply filament power to tubes whose cathodes are at approximately zero potential. The center tap of T-402 is returned to minus 125 volts and this transformer supplies filament current to tubes whose cathodes are returned to potentials of minus 100 volts or lower. The center tap of T-404 is returned to ground and this transformer provides power for the bezel illumination lamps for the cathode ray tubes and also provides the power for the filament connections on the external power connector, J-609.

6.6 Test Unit

In the descriptions of the circuits of the Test Unit which follow, reference should be made to the circuit diagram, Figure C-21, and to the photographs of the Unit, Figures C-11, C-12, and C-13.

6.6.1 Synchronizing pulse generation

Synchronizing pulses to trigger the slow sweep of the Sonar Signal Analyzer are generated in the Test Unit by the multi-vibrator V-1, a 5965. The time constant of the multi-vibrator, and therefore the spacing of the synchronizing pulses, is controlled by the Range Switch which provides proper timing for ranges of 500, 1000, 3000, and 6000 yards. A fifth position of the Range Switch makes provision for the external synchronization. A synchronizing input terminal is provided on the front panel. Minor adjustments of the trigger-pulse rate may be made by the Range Vernier, a screwdriver-adjust control on the front panel. A diode, V-4A (one-half of a 6AL5) is used to limit the maximum

voltage across the capacitors used in the range determining circuits.

One output of the multi-vibrator tube, V-1, serves as the synchronizing pulse output. The second plate of the multi-vibrator is connected through a diode to the multi-vibrator which controls the relay operation described below.

6.6.2 Relay operating circuit

A Millisec relay is used to provide one pulse to simulate initial reverberation and a second pulse to simulate an echo. The arm and two fixed contacts of the relay appear on terminals on the front panel. The operation of the relay is controlled by the one-shot multi-vibrator, V-2, a 5965. The duration of the simulated reverberation and echo is controlled by the Pulse Length Switch. This switch selects any one of three capacitors which vary the time constant of the one-shot multi-vibrator to provide pulse lengths of 6, 30, and 80 milliseconds. A 6AL5 connected to the arm of the Pulse Length Switch is used to limit the voltage across the capacitors in the pulse length circuit.

The trigger for the relay-operating multi-vibrator comes from two sources: 1, the plate of the synchronizing pulse generator which triggers the relay for the simulation of initial reverberation; and 2, from the Schmidt trigger which determines the echo range. The two trigger pulses are fed through diodes which prevent interaction between the synchronizing pulse generating circuits and the echo range pulse generating circuits.

6.6.3 Echo range determining circuits

To determine the position of the relay operation which provides the simulated echo, a 6201 tube (V-3) is used as a Schmidt trigger. The variable input to the trigger is the voltage across the range-determining capacitor in the synchronizing pulse generator, while the Echo Range Control varies the reference voltage fed to the other grid. The output from the Schmidt trigger is fed through a diode to the grid of the relay-operating multi-vibrator.

6.6.4 Power requirements

The Test Unit receives its power from the regulated supplies in the Sonar Signal Analyzer. These connections are made by a five-pin cable between the Test Unit and the five-pin connector, J-609, on the rear panel of the Display Unit. The Unit requires plus and minus 250 volts DC and 6.3 volts AC. The wiring of the connector is shown on the schematic diagram, Figure C-21.

6.7 Access to components

6.7.1 Display Unit

The Display Unit is mounted on slides so that it may be pulled from its dust cover for access to the chassis to permit maintenance and adjustment. Two catches on the front panel release the unit. The top cover is held by four fasteners that release when given a one-quarter turn counter-clockwise.

6.7.2 Chassis removal

The individual chassis of the Analyzer may be taken from their mountings for maintenance by releasing catches at each end. Before removing the chassis, several plug-in connections must be disconnected. On the left chassis, a Cannon three-pin cable connector, P-401, which serves as the main input for the sonar signal, must be removed. On both the left and the right chassis, the leads between the chassis and the cathode ray tube deflection plates must be disconnected, either at the chassis where all eight leads are removable by taking out two screws and pulling out the entire plug bar, or from the caps of the cathode ray tubes. Before taking the ACIM chassis from its track, the twin-ax connector, P-402, located on the left side of this chassis near the top must be disconnected.

6.7.3 Extension cables

To facilitate maintenance and adjustments of circuits of the Analyzer, extension cables are provided so that the chassis may be operated when removed from their normal mountings. For the left and right chassis, two cables with 24-pin connectors are provided. The unshielded cable is always used in the rear connector, while the shielded cable is used in the forward connector. The ground lead on the shielded cable must be clipped to a chassis ground to provide shielding of the leads. A single 32-pin extension cable is provided for the ACIM chassis.

6.7.4 High voltage power supply and filament transformers

The filament transformers and all high-voltage power supply components other than the rectifiers are mounted inside the main channel of the Display Unit. A sub-channel

which mounts the chassis connectors and their components is hinged at the rear to provide access. If access is required, all chassis must be taken from the unit, five screws must be removed from each side of the main channel (see photograph, Figure C-14) and the sub-channel can then be swung down. The filler panel in the bottom cutout of the dust cover must be removed to provide clearance for this sub-channel.

6.7.5 Power supplies

To remove the two power supply chassis from the Main Power Supply unit, the doors covering the supplies should be opened. A retaining screw located in the front center of the chassis must be loosened and the power supply chassis can then be pulled out. When replacing these chassis, care must be used to ensure that the chassis engage the tracks in which they slide, otherwise damage to the connectors may result because of misalignment of the chassis.

Appendix A.

Detailed summary of component functions.

A.1. Component functions in circuit sub-sections (see block diagram, Figure 2-3).

Serial	Part Type	Chassis	Function
<u>Input Attenuator</u>			
S 525		Front Panel	Controls relays K102 and K103 which control an attenuator to alter the gain of the pre-amplifier. In "high," K102 is energized; in "medium," K103 is energized; and in "low," both are released.
K 102	SM5LS	Left	When energized, connects 500-ohm cathode feedback resistor to V101A to allow maximum gain of pre-amp.
K 103	SM5LS	Left	When energized, connects 5k cathode feedback resistor to V101A which reduces gain to medium.
<u>Pre-amplifier</u>			
V 101A	6072	Left	Input stage of sonar input pre-amplifier. Cathode contains input feedback attenuator.
V 101B	6072	Left	Output stage of sonar input pre-amplifier.
<u>Input Selector</u>			
R 252		Right	Attenuates carrier input to V215B.
V 215B	12AX7	Right	Amplifies sonar carrier and feeds V215A.
V 215A	12AX7	Right	Follows amplified sonar carrier from V215B and feeds relay K101.

Part		Chassis	Function
Serial	Type		
V 318	5963	ACIM	One-shot multi-vibrator triggered by flyback of slow sweep energizes K302 directly and K101 (through panel Zero Reference Selector, S524) for a short time at the beginning of the A-scan.
K 101	Terado Micro Relay	Left	Selects amplified sonar input when released or carrier when energized.

Logarithmic Amplifier

V 102B	12AX7	Left	Input stage amplifies selected input.
V 103B	12AT7	Left	Output stage amplifies selected input to drive logaten and amplitude selector.
Logaten		Left	Non-linear circuit in temperature-regulated oven. Output voltage is proportional to the logarithm of the input voltage.
V 102A	12AX7	Left	Input stage amplifies logarithmic output of logaten.
V 103A	12AT7	Left	Output stage amplifies logarithmic output of logaten to drive ACIM and K301.

ACIM

V 302A	6BQ7A	ACIM	First stage of clipper amplifier to increase rise time of signal at axis crossings.
V 302B	6BQ7A	ACIM	Second stage like V302A.
V 303A	6BQ7A	ACIM	Third stage like V302A.
V 303B	6BQ7A	ACIM	Output clipper amplifier to drive pulse-forming network in grid circuit of V304A.

Part		Chassis	Function
Serial	Type		
V 304A	6BQ7A	ACIM	Amplifies pulse from pulse-forming network and drives grid of V304B positive.
V 304B	6BQ7A	ACIM	Applies positive pulse at tuned circuit at J301 and then allows it to oscillate naturally.
J 301		ACIM	Tuned circuit connected here increases ACIM sensitivity about n times when n cycles elapse before sawtooth is sampled.
V 305A	6BQ7A	ACIM	Clipper amplifier like V302A, increases rise time at axis crossings of damped sine wave from tuned circuit connected at J301.
V 305B	6BQ7A	ACIM	Same as V302B.
V 306A	6BQ7A	ACIM	Same as V303A.
V 306B	6BQ7A	ACIM	Same as V303B.
V 307A	6BQ7A	ACIM	Same as V304A.
V 307B	6BQ7A	ACIM	Charges sawtooth condenser positively and then releases it to discharge through V319A to produce a linear sawtooth.
V 319A	5751	ACIM	Acts as constant current source to discharge the sawtooth condenser to produce the sawtooth to be sampled by V309.
V 308	6BQ7A	ACIM	Cathode follower provides low impedance source to supply sampler with the sawtooth and also inverts the sawtooth for neutralizing the shunt capacity of the sampling switch, V309.
V 311A	6BQ7A	ACIM	Amplifies trigger pulse from pulse-forming network in grid circuit of V304A and feeds it to V311B.

Part		Chassis	Function
Serial	Type		
V 311B	6BQ7A	ACIM	Follows pulse from V311A and drives grids of switch tube, V309.
V 309	12AU7	ACIM	Sampling switch tube - allows storage condenser (47 μ f - C318) to charge to the value of the sawtooth at instant when trigger is fed in from V311B.
V 310	5814	ACIM	Follows sampled voltage stored on condenser (C318) and produces the raw ACIM output which is fed to the panel range-rate Zero Reference Selector.

Range-rate Zero Reference Selector

V 107A	12AT7	Left	Follows voltage of slow sweep condenser and feeds inverted slow sweep voltage to V318 (ACIM) which can operate relay K101.
V 318	5963	ACIM	One-shot multi-vibrator triggered by slow sweep energizes K302 directly and K101 (through panel Zero Reference Selector, S524) for a short time at the beginning of the A-scan.
S 524		Panel	Selects range-rate Zero Reference level as follows: On "internal," K101 remains de-energized and the raw ACIM output is fed directly to the DC amplifier by V312A. On "ping," K101 is controlled by V318 and the ACIM output coupled through C321 is zeroed by K302 at the level corresponding to the frequency of the sonar carrier. On "reverberation," K101 is de-energized and the ACIM output coupled through C321 is zeroed by K302 at the level corresponding to the frequency of the reverberation from the water nearby.

Part		Chassis	Function
Serial	Type		
K 101	Terado Micro Relay	Left	Selects amplified sonar input when released, or carrier when energized.
K 302	SM5LS	ACIM	Charges 0.5 μ fd (C321) coupling capacitor to the average value of the raw ACIM output corresponding to the selected signal. When K302 releases, the charge remains on the condenser. The condenser voltage subtracts from the raw ACIM output to produce a voltage which is zero when the raw ACIM output equals the stored voltage. Thus, the ACIM zero is automatically set.
V 312A	12AU7	ACIM	Provides low impedance output from the Zero Reference Selector.

Range-rate Full-scale Selector

R 367		ACIM	"ACIM gain" - internal adjustment for range-rate full-scale.
R 365		ACIM	"ACIM zero" - internal zero adjustment.
V 313A	6072	ACIM	Input stage of adjustable-gain DC amplifier to amplify zeroed ACIM output.
V 313B	6072	ACIM	Second stage of DC amplifier.
V 314A	6BQ7A	ACIM	Amplifies output of V313B and feeds it to V314B.
V 314B	6BQ7A	ACIM	Cathode follower output stage of adjustable-gain DC amplifier drives gated integrator and adjustable feedback resistors of DC amplifier.
S 523		Panel	Shorts out feedback resistors between V313, V314 to decrease the gain of the DC amplifier, thus altering the range-rate scale.

Part			
Serial	Type	Chassis	Function
<u>Gated Integrator</u>			
V 316	6AL5	ACIM	Rectifies and filters the ACIM signal input and applies the resulting envelope as a change of bias voltage to the grids of V317.
V 317B	12AX7	ACIM	The cathode of V317A is driven by V317B which is free to follow the rapid changes in the signal envelope produced by V316. V317A amplifies the grid-to-cathode voltage which is thus the difference between the average and instantaneous values of the envelope. Hence, V317B can turn "on" V317A when the instantaneous value of the envelope is more negative than the average value of the envelope.
V 317A	12AX7	ACIM	Normally cut off, so allows V315 to conduct. Slow changes in grid bias appear equally at both grids of V317, but rapid changes are filtered out by the RC filter at grid of V317A. Thus, the grid of V317A responds to the average value of the signal envelope.
R 389		ACIM	"Gate Threshold" sets the bias of V317A and thus adjusts the amount that the instantaneous envelope must fall below the average envelope before V317A can be turned "on" by V317B.
V 315	12AU7	ACIM	Connects ACIM output to RC integrator when K303 and K304 are energized, but not when the envelope of the input signal to the ACIM is less than the average value of the envelope. This restriction is applied to ignore the violent excursions of the ACIM which appear at rapid-phase reversals of

Part				
Serial	Type	Chassis		Function
				the input signal such as occur when two sine waves partly cancel one another to produce a null or dip in the envelope.
S 521		Panel		When in fully counter-clockwise position, the switch turns off relays K303, K304 which disconnect the gated integrator.
K 303 } K 304 }		ACIM		Both relays operate together when the panel smoothing control is rotated clockwise away from its stop. When energized, the relays insert the gated integrator which smoothes the zeroed ACIM output before it is passed to the lower vertical deflection amplifiers. When released, the relays feed the zeroed ACIM output without smoothing to the lower vertical deflection amplifiers.
R 523	5 meg	Panel		Increases the degree of smoothing by increasing the integrator time constant.
V 301B	6BQ7A	ACIM		Feeds final range-rate voltage to the lower vertical deflection amplifiers.

Amplitude Scale Selector

S 522		Panel		When in fully counter-clockwise position, the switch turns off relay K301 which then selects the logarithmic output for feeding the upper scope traces.
K 301	SM5LS	ACIM		Selects signal output and feeds it to V301A from either the logarithmic or the linear amplifier when the relay is released or energized respectively. The relay is operated by the "log-linear" switch on the linear attenuator on the front panel.

<u>Part</u>			
<u>Serial</u>	<u>Type</u>	<u>Chassis</u>	<u>Function</u>
R 524	100 k	Panel	Attenuator for linearly-amplified signal to be fed to both upper scope traces.

Electronic Switch (Vertical Deflection)

V 115A	12BH7	Left	Connects the range-marker vertical tracing voltage to the upper vertical deflection amplifier when V113A connects the range marker position voltage to the upper horizontal deflection amplifier.
V 115B	12BH7	Left	Connects the amplified signal from V301A when V113B connects the slow sweep voltage to the upper vertical deflection amplifier.

Deflection Amplifiers

A-Scan

Upper Vertical

V 116A	12BH7	Left	Drives deflection plate, J, and inverter, V104B, with voltage switched to it by V115.
R 134		Left	Vertical position control.
V 104B	12AT7	Left	Inverter to drive upper vertical deflection plate, H.

Upper Horizontal

V 116B	12BH7	Left	Drives deflection plate, G, and inverter, V104A, with voltages switched to it by V113.
R 125		Left	Horizontal position control.
V 104A	12AT7	Left	Inverter to drive upper horizontal deflection plate, F.

Part		Chassis	Function
Serial	Type		

Lower Vertical

V 301B	6BQ7A	ACIM	Feeds final range-rate voltage to the lower vertical deflection amplifier.
R 148		Left	Vertical position control.
V 105B	12AX7	Left	Inverter to drive lower vertical deflection plate, D.

Lower Horizontal

R 155		Left	Horizontal width.
V 111B	12BH7	Left	Supplies slow sweep voltage to lower horizontal deflection plate, A, and inverter V105A.
R 139		Left	Horizontal position control.
V 105A	12AX7	Left	Inverter to drive lower horizontal deflection plate, B.

Expanded A-Scan

Upper Vertical

V 301A	6BQ7A	ACIM	Follows signal selected by K 301 and feeds it to upper vertical deflection amplifier.
R 266		Right	Vertical position control.
V 216B	12AX7	Right	Inverts voltage on deflection plate, J, and applies it to deflection plate, H.

Upper Horizontal

V 111A	12BH7	Left	Follows voltage on fast sweep condenser to drive heater of V110 and feed fast sweep to V216A.
R 255		Right	Horizontal position control.

Part		Chassis	Function
Serial	Type		
V 216A	12AX7	Right	Inverts voltage on deflection plate, G, and applies it to deflection plate, F.

Lower Vertical

V 301B	6BQ7A	ACIM	Feeds final range-rate voltage to the lower vertical deflection amplifier.
R 277		Right	Vertical position control.
V 217B	12AX7	Right	Inverts voltage on deflection plate, C, and applies it to deflection plate, D.

Lower Horizontal

R 279		Right	Horizontal size adjustment.
V 111A	12BH7	Left	Follows voltage on fast sweep condenser to drive heater of V110 and feed fast sweep to V217A.
R 267		Right	Horizontal position control.
V 217A	12AX7	Right	Inverts voltage on deflection plate, A, and applies it to deflection plate, B.

Slow Sweep Generator

V 214	2D21	Right	Discharges sweep condenser when externally triggered with positive pulse. Heater-cathode leakage current is reduced by keeping heater close to cathode voltage with V107A.
V 106A	6AL5	Left	Limits end of slow sweep voltage to approximately -200 volts.
V 107A	12AT7	Left	Follows voltage of slow sweep condenser and feeds inverted slow sweep voltage to V318 (ACIM) which can operate relay K101.

Serial	Part Type	Chassis	Function
<u>Fast Sweep Generator</u>			
V 108	6AL5	Left	Comparator: selects whichever is the more negative, the slow sweep voltage or the range marker voltage, and feeds it to V109A.
V 109A	12AT7	Left	Follows output from V108 and drives V109B.
R 169	250 k	Left	Adjusts pulse width of V109B to be constant over full extent of sweep.
V 109B	12AT7	Left	Amplifies difference between comparator output voltage via V109A and part of the range marker voltage via R169.
V 107B	12AT7	Left	Amplifies pulse generated by V109B.
I 109	NE2	Left	When V107B cuts off, it ionizes I109 which produces fast-rising trigger to fire V110.
V 110	2D21	Left	Discharges fast sweep condenser when triggered by I109.
V 106B	6AL5	Left	Limits end of fast sweep voltage to approximately -100 volts.
V 111A	12BH7	Left	Follows voltage on fast sweep condenser to drive heater of V110 and feed fast sweep to V216A, V217A.
<u>Range Marker and Vernier</u>			
R 527	100 k	Panel	Positions the range marker by providing the adjustable voltage which is compared to the sweep voltage by V108.
V 112B	12AT7	Left	Supplies switch V113B with range marker position voltage.
V 112A	12AT7	Left	Provides switch V113A with slow sweep.

Part			
Serial	Type	Chassis	Function

Range Marker Generator

V 114	12BH7	Left	Free-running multi-vibrator operates switches V115, V113, drives marker-tracing generator V117 and feeds pulse-shaping circuits for blanking and intensifying trace as follows: The two 1N98 diodes, D102, D104, deliver a negative blanking pulse from the differentiated square wave whenever the multi-vibrator V114 changes state and V113 and V115 are in the transition state.
-------	-------	------	--

The circuit containing the 500 μ f condenser (C141), R178 and 1N39 (D103) produce a rounded positive pulse which is zero during blanking but increases rapidly and then decays slowly to brighten the range marker trace to compensate for the more rapid movement of the C.R.T. spot at the beginning of its vertical motion.

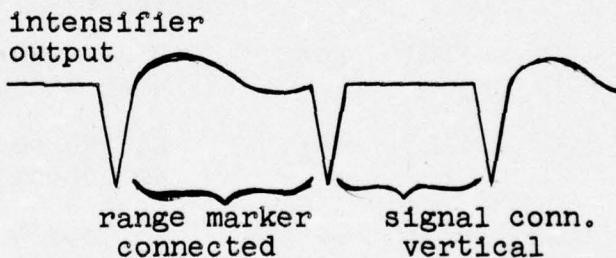

V 117	6135	Left	Allows C133 to charge through R185 to produce the range marker vertical tracing voltage which is fed to V115A.
-------	------	------	--

Electronic Switch (Horizontal Deflection)

V 113A	12BH7	Left	Connects slow sweep voltage to A-scan upper horizontal deflection amplifier when V114A is not conducting.
--------	-------	------	---

Part		Chassis	Function
Serial	Type		
V 113B	12BH7	Left	Connects range marker position voltage to A-scan upper horizontal deflection amplifier when V114B is not conducting.

Reference Voltage

V 206	5651	Right	Internal voltage reference for positive regulator.
-------	------	-------	--

Auxiliary Regulator

V 212	6U8	Right	Controls series tube V213 to maintain +160-volt bus.
V 213	12BH7	Right	The voltage across this series regulator tube drops the +250 volts down to +160 volts.

Positive Regulator

V 211	12AX7	Right	Compares and amplifies the difference between the reference voltage and 1/3 of the +250-volt bus to ground. Use a +87-volt external ref. or the internal ref. V206.
V 210	12AX7	Right	Push-pull DC amplifier follows comparator V211 and drives V209.
V 209A	6U8	Right	Triode inverts one output of DC amplifier to produce one of the push-push outputs to be added in V209B.
V 209B	6U8	Right	Pentode adds push-push outputs of DC amplifier to produce a single-ended output to control series regulator tubes.
V 207) V 208)	6080	Right	The voltage across these series regulator tubes drops the positive supply voltage to +250 volts.

Part		Chassis	Function
Serial	Type		
<u>Negative Regulator</u>			
V 205	12AX7	Right	Compares and amplifies the difference between $1/3$ of the -250 volt bus to ground, and $1/6$ of the -250 volt bus to the +250 volt bus.
V 204	12AX7	Right	Same as V210.
V 203A	6U8	Right	Same as V209A.
V 203B	6U8	Right	Same as V209B.
V 201) V 202)	6080	Right	The voltage drop across these series regulator tubes displaces the negative supply until the negative terminal of the negative supply lies at -250 volts with respect to ground.

A.2 Listing of external connections.

Left Terminal Strip (TS-401)

Pin

- 1 - Chassis Ground
- 2 - Circuit Ground
- 3 - Reference In
- 4 - Reference Out
- 5 - Circuit Ground
- 6 - Cursor Position Voltage
- 7 - Circuit Ground
- 8 - 110 AC Regulated
- 9 - 110 AC Common
- 10) } - 6.3 volts AC CT at Ground.
- 11) }
- 12 - Pin one J609 through F601
- 13 - Pin five J609
- 14 - Check Point (Saw Tooth)
- 15 - Circuit Ground
- 16 - Check Point (Ringer)
- 17 - Circuit Ground
- 18 - Sweep Trigger
- 19 - Circuit Ground
- 20 - No Connection

Right Terminal Strip (TS-402)

Pin

- 1 - Raw ACIM Out
- 2 - Smooth ACIM Out
- 3 - Zeroed ACIM Out
- 4 - Circuit Ground
- 5 - Circuit Ground
- 6 - ACIM Input
- 7 - Logarithmic Signal
- 8 - Logarithmic Signal
- 9 - Linear Signal
- 10 - Circuit Ground
- 11 - Fast Sweep
- 12 - Circuit Ground
- 13 - Slow Sweep
- 14 - Circuit Ground
- 15 - Fast Sweep Condenser
- 16 - Circuit Ground
- 17 - Slow Sweep Condenser
- 18 - Circuit Ground
- 19 - Carrier In
- 20 - Circuit Ground

Rear Power Socket (J-609)

- 1 - Left Terminal Strip No. 12 Through Rear Panel Fuse
- 2 - Positive 250V
- 3 - Circuit Ground
- 4 - Negative 250V
- 5 - Left Terminal Strip No. 13

Appendix B.

Axis Crossing Interval Meter

The Axis Crossing Interval Meter (ACIM) was developed in this Laboratory in 1951 for rapid and precise measurement of the frequency of a periodic signal⁽¹⁾, or of the cycle-to-cycle variations in period of a non-periodic signal. The ACIM measures the time interval between alternate zero crossings of an input signal; i.e., between positive-going or negative-going zero crossings, and produces an output voltage inversely proportional to this time interval. Thus, the ACIM output voltage is directly proportional to the frequency of a periodic input signal.

The original ACIM was a wide-band device, operating over a 100-to-one frequency range from very low frequencies (below 10 cycles per second) up to several hundred kilocycles per second. Subsequent modifications⁽²⁾ permit measurements on periodic signals or on narrow-bandwidth non-periodic signals with increased gain.

The input signal is first amplified and clipped to produce a square wave with periods identical to those of the input signal. The square wave is then fed to a pulse generator which produces a pulse at each positive-going or negative-going zero crossing of the signal. These pulses are used to sample a sawtooth waveform that starts at a fixed voltage and has a constant slope.

(1) MIT-AL Quarterly Progress Report, July-September 1951, pp. 32-34.

(2) MIT-AL Quarterly Progress Report, October-December 1952, pp. 7-8.

The sampling pulse is also fed to a delay circuit. The delayed pulse triggers the sawtooth generator and regenerates the sawtooth which is sampled at the next zero crossing.

Each sampled voltage is held until the next sample is taken. The output of the sampling circuit is thus a stepped waveform, as shown in Figure B-1. The magnitude of each sampled voltage is inversely proportional to the sampling pulse period immediately preceding.

In this form, the ACIM is essentially a wide-band instrument. The gain, bandwidth, and operating frequency range are jointly determined by the amplitude and slope of the sawtooth waveform. The maximum frequency of operation is limited by the delay between the sampling and trigger pulses. The minimum frequency of operation is limited by the holding time of the storage capacitor in the sampling circuit; the charging time of this capacitor may set a limit on the upper frequency of operation with practicable sampling circuits.

Using a 200-volt sawtooth and a delay of one microsecond, the frequency range of the basic ACIM is about 100-to-one, as indicated above, without readjustment of the sawtooth slope. By suitable adjustment of the sawtooth slope and the storage capacitor, the operating frequency range may be set anywhere from about 10 cycles per second up to several hundred kilocycles per second.

The ACIM incorporated in the Sonar Signal Analyzer differs from the basic ACIM described above in that it is especially adapted for measurements on signals of relatively narrow bandwidth. As the bandwidth of a signal is restricted,

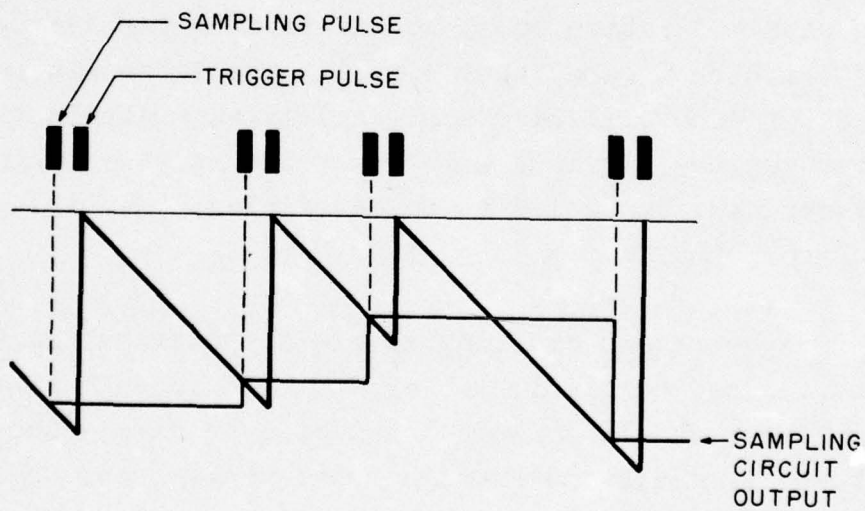
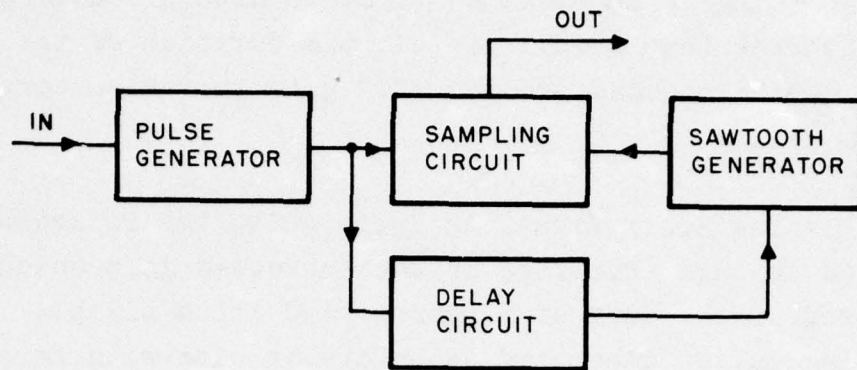

Figure B-1. Block diagram and principle of operation of Axis Crossing Interval Meter.

the total range of fluctuation in period-length is correspondingly restricted. With the a priori knowledge that a zero crossing is constrained to occur within a time interval much shorter than a full period, the duration of the sawtooth can be reduced and the ACIM gain increased correspondingly.

In the Sonar Signal Analyzer ACIM, the following method is used to take advantage of the increased gain which can be realized in the case of a narrow-band input signal. Each sampling pulse (generated as before at alternate zero crossings of the input signal) triggers a damped sine wave from a ringer circuit (a parallel LC circuit) with a highly stable natural frequency set to be seven times the center frequency for which the ACIM is adjusted. The ringer output is amplified and clipped and used to generate a sequence of trigger pulses, each of which in turn triggers a steep-slope sawtooth with a duration equal to one-seventh the average period of the narrow-band input signal. The first six periods of the ringer oscillation serve solely as a stable time delay between the previous sampling pulse and the beginning of the steep sawtooth which is to be sampled; the first six sawteeth are not used.

The next zero crossing of the input signal occurs during the period of time covered by the seventh sawtooth. A sampling pulse is generated and used to sample the sawtooth and to clamp and retrigger the ringer, and the sequence just described is repeated.

The natural frequency selected for the ringer circuit clearly depends on the bandwidth and average frequency of the input signal and on the requirements for increased gain over that provided by the single-sawtooth broad-band ACIM.

Since the ringer inductor and capacitor are external to the SSA circuits, selection of these components is left to the discretion of the operator to meet particular performance requirements. If the inductor and capacitor are replaced by a resistor, the Analyzer ACIM functions as a broad-band unit for use in the frequency range of 30-200 kilocycles per second approximately. Conversion to broad-band operation at lower frequencies would require modifications to the Analyzer circuits to provide a delayed trigger pulse and to increase the storage capacitor in the sampling circuit.

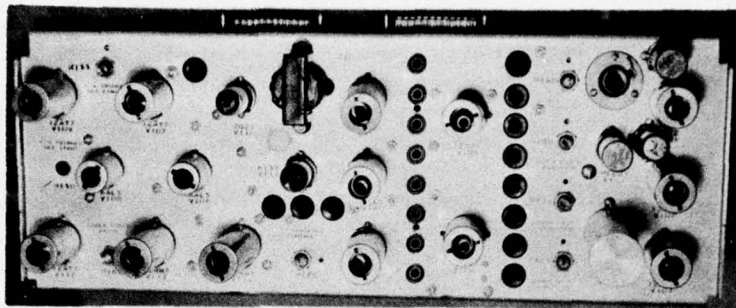

Figure C-1. Left chassis - top view.

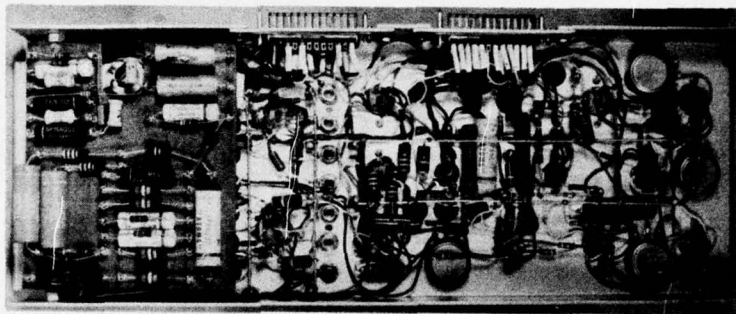

Figure C-2. Left chassis - bottom view.

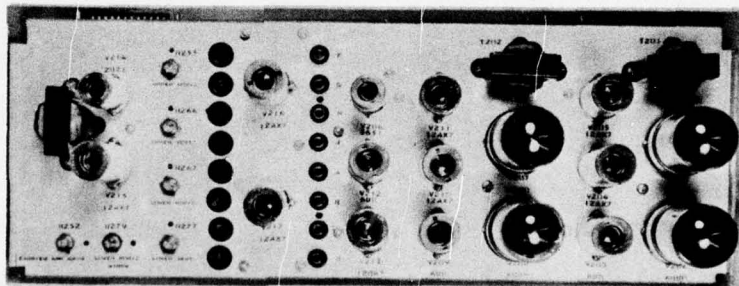

Figure C-3. Right chassis - top view.

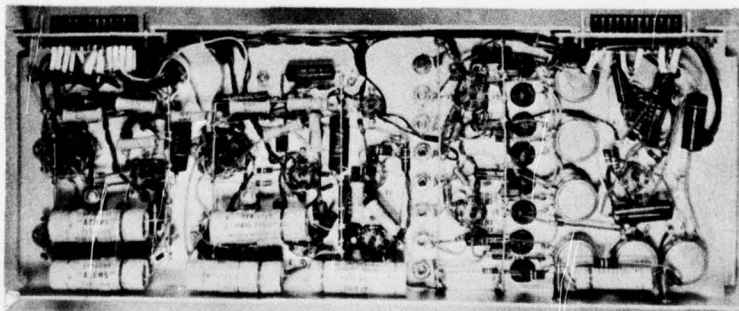

Figure C-4. Right chassis - bottom view.

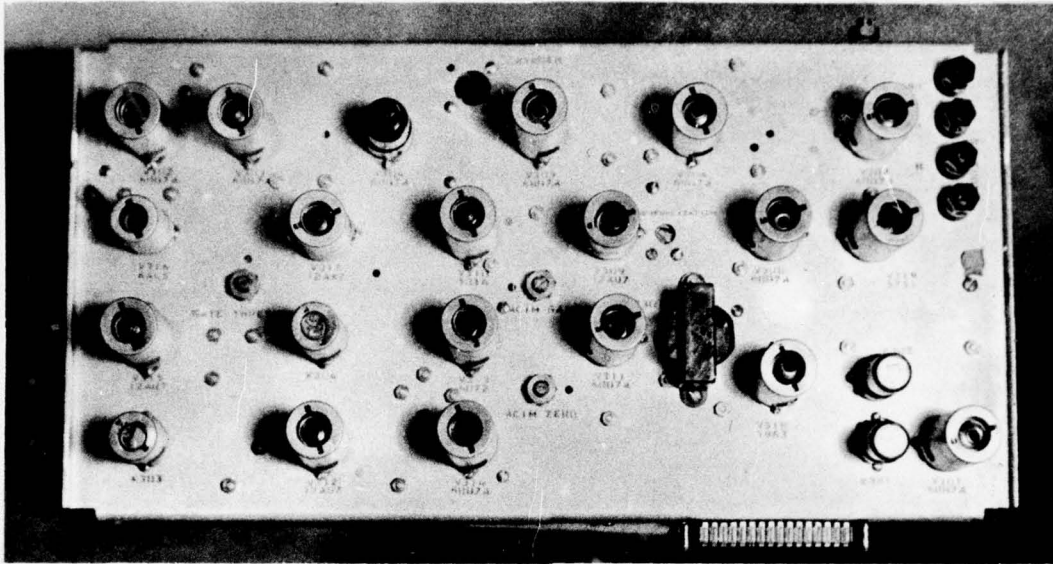

Figure C-5. ACIM chassis - top view.

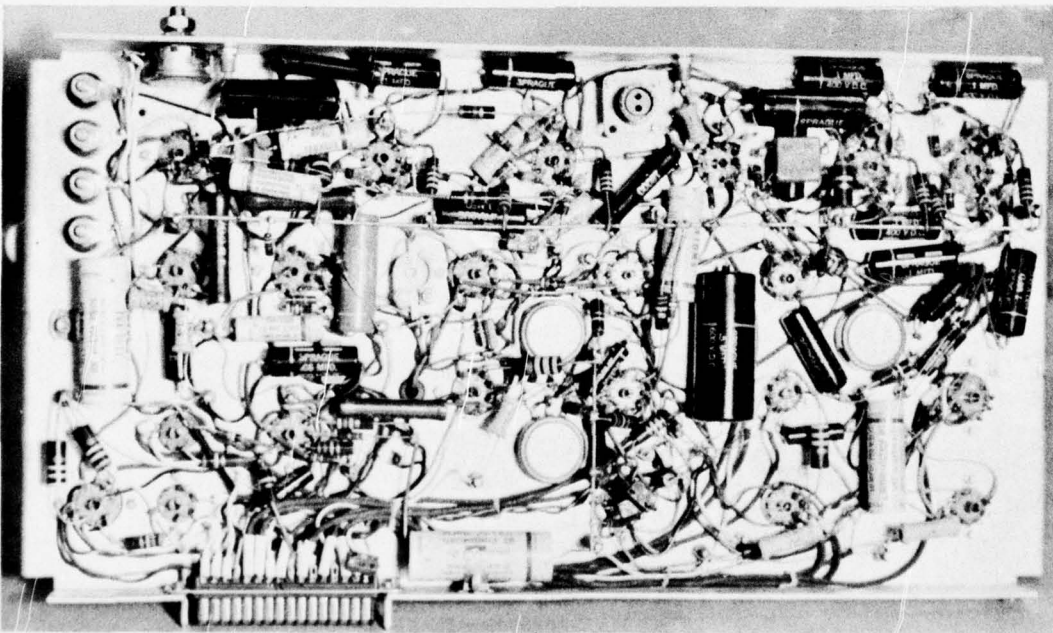

Figure C-6. ACIM chassis - bottom view.

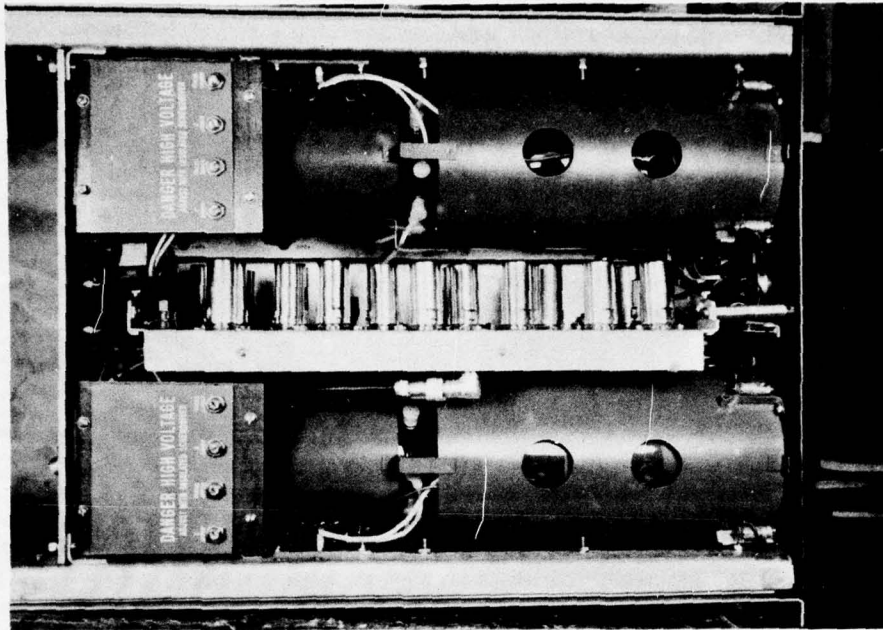

Figure C-7. Main frame - top view.

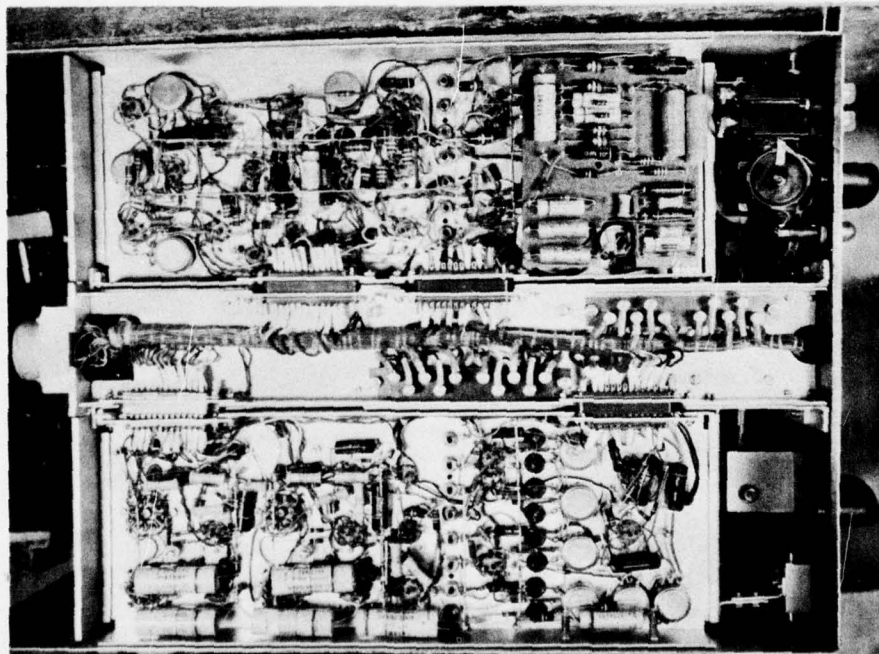

Figure C-8. Main frame - bottom view.

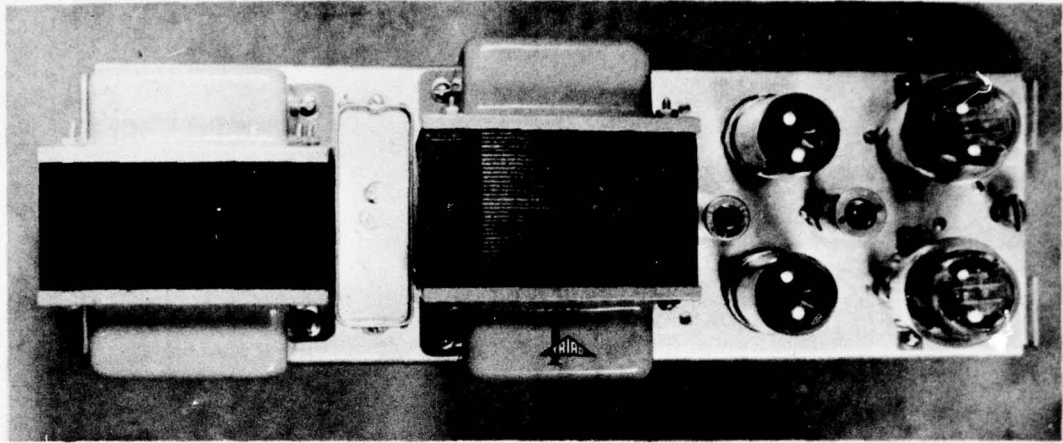

Figure C-9. Power supply - top view.

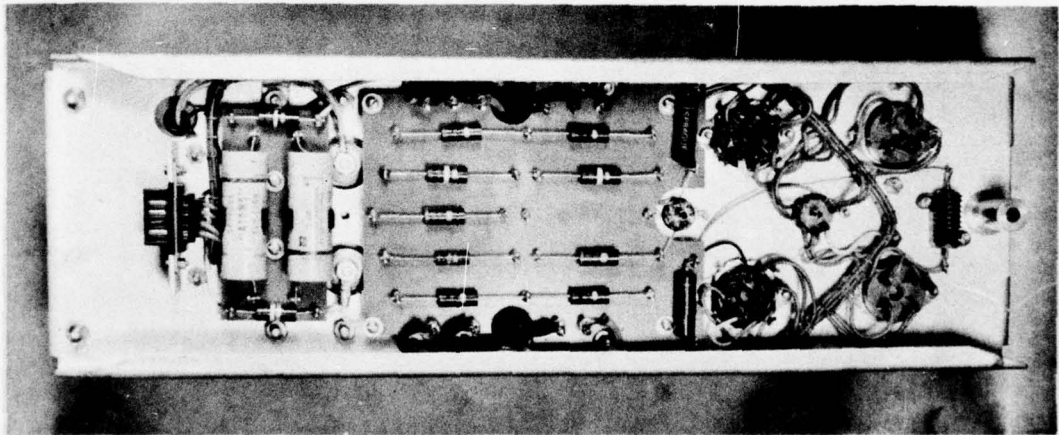

Figure C-10. Power supply - bottom view.

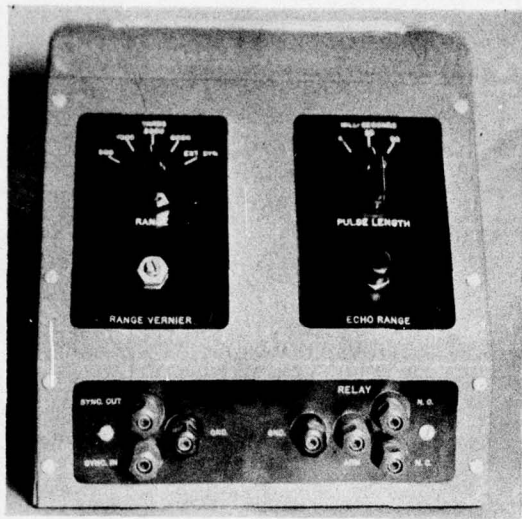

Figure C-11. Test unit - front panel.

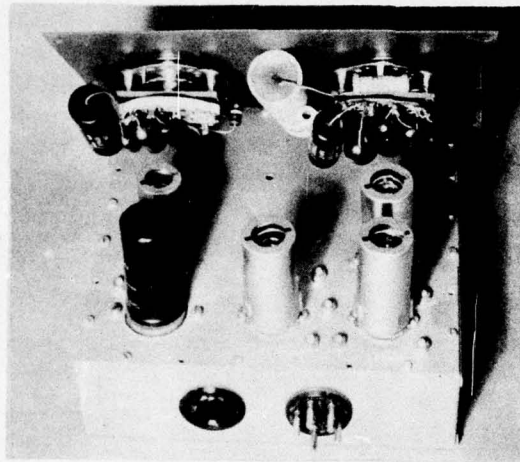

Figure C-12. Test unit - chassis top.

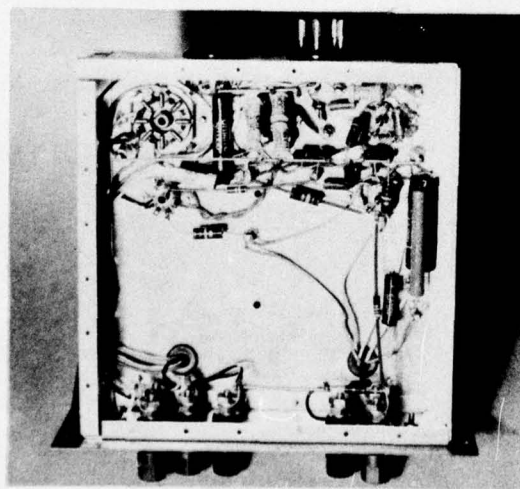

Figure C-13. Test unit - chassis bottom.

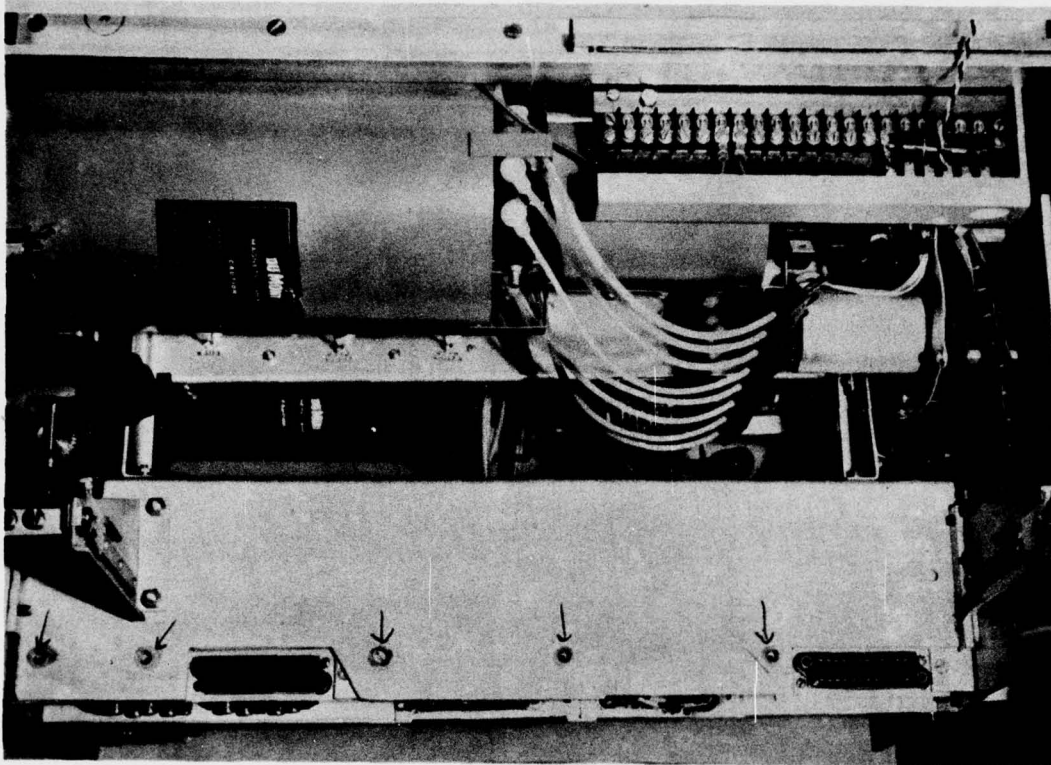

Figure C-14. Right side of Analyzer unit showing screws which must be removed to drop transformer channel. (Left side of Analyzer is similar.)

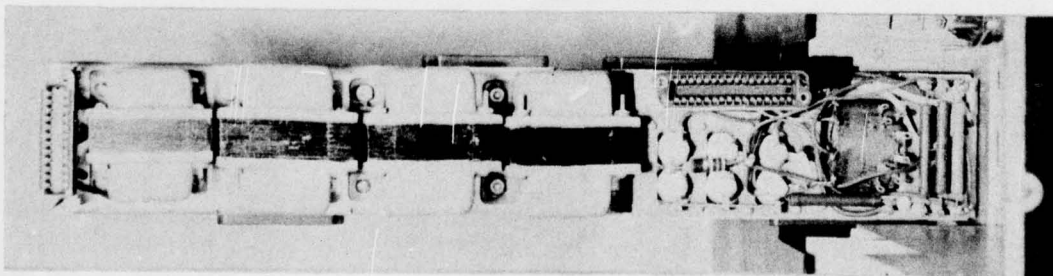
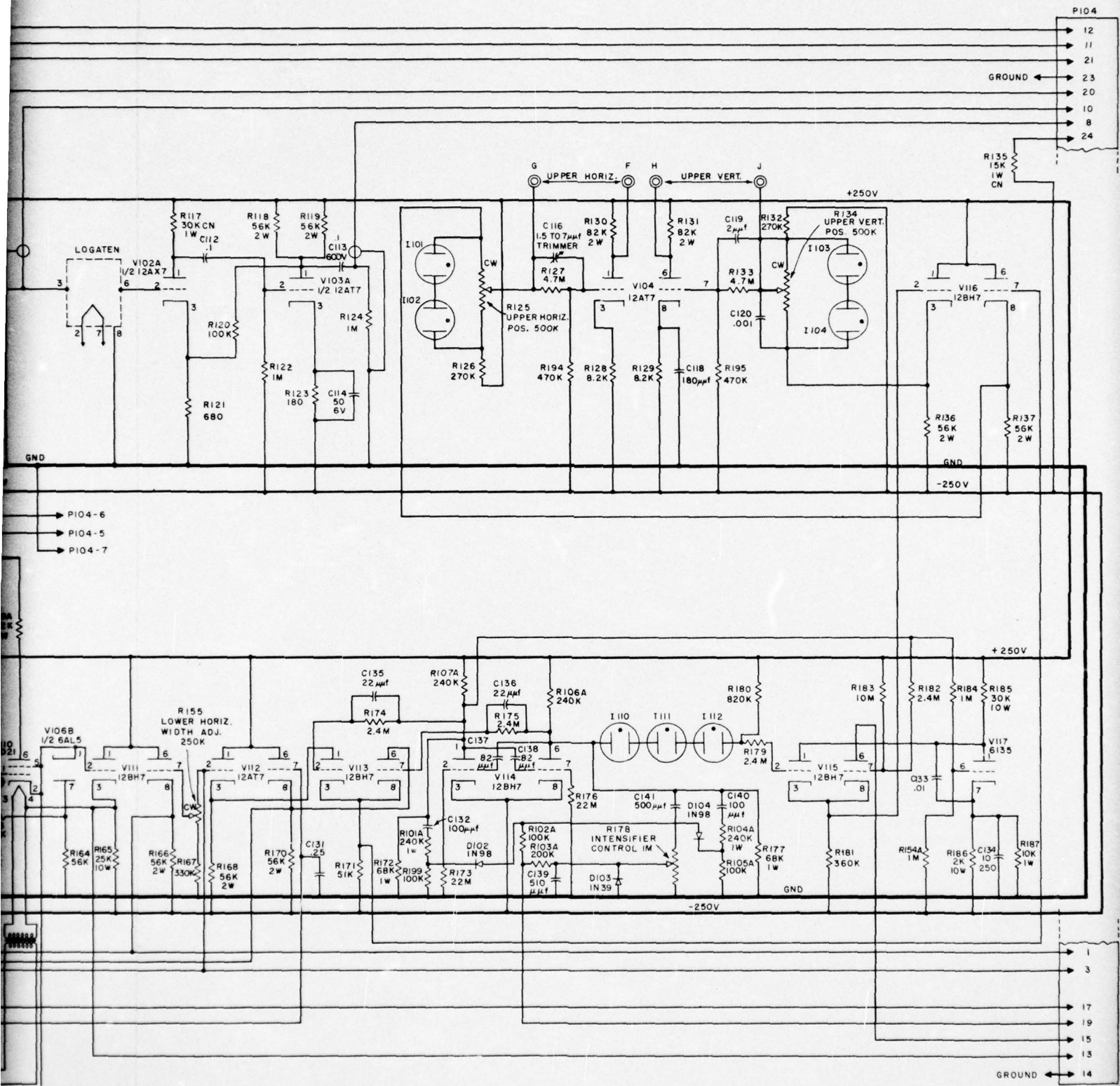

Figure C-15. Top view of transformer channel.



NOTES

1. CONDENSER VALUES IN μ f UNLESS NOTED
2. CONDENSER 400V UNLESS NOTED
3. RESISTOR VALUES IN OHMS UNLESS NOTED
 $K = 1000\Omega$
 $M = 1,000,000\Omega$
4. RESISTORS 1/2 WATT UNLESS NOTED
5. CN DENOTES 1% LOW NOISE RESISTORS
6. I DENOTES NE-2 NEON BULBS

SONAR SIGNAL ANALYZER
 LEFT HAND CHASSIS
 FIGURE C-16

2

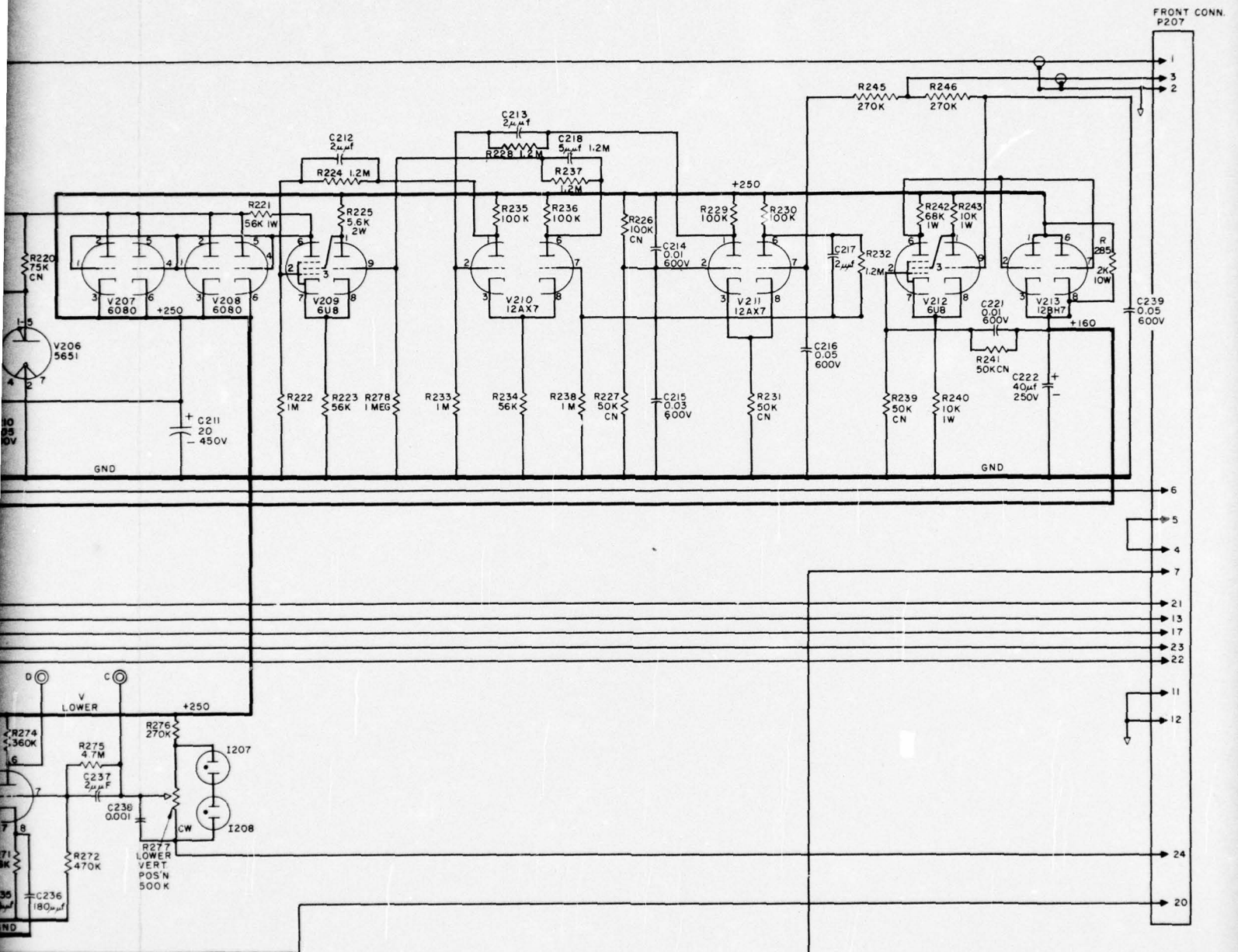

- NOTES:
1. CONDENSER VALUES IN μf UNLESS NOTED
 2. CONDENSER 400V UNLESS NOTED
 3. RESISTOR VALUES IN OHMS UNLESS NOTED
 $\text{K} = 1000 \Omega$
 $\text{M} = 1,000,000 \Omega$
 4. RESISTORS 1/2 WATT UNLESS NOTED
 5. CN DENOTES 1% LOW NOISE RESISTORS
 6. I DENOTES NE-2 NEON BULBS

SONAR SIGNAL ANALYZER
 RIGHT HAND CHASSIS
 FIGURE C-17

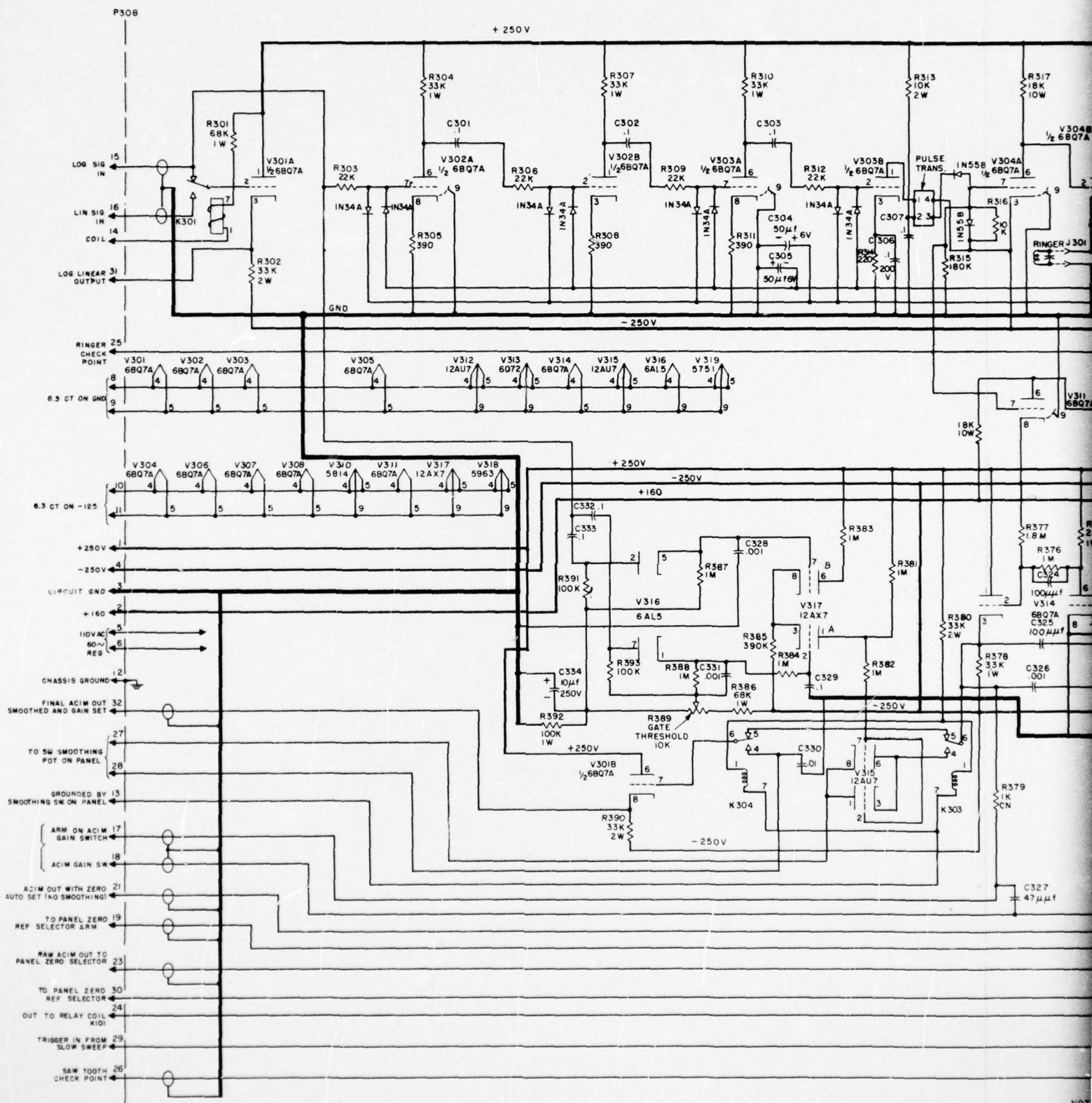

NOT
1.
2.
3.
4.
5.

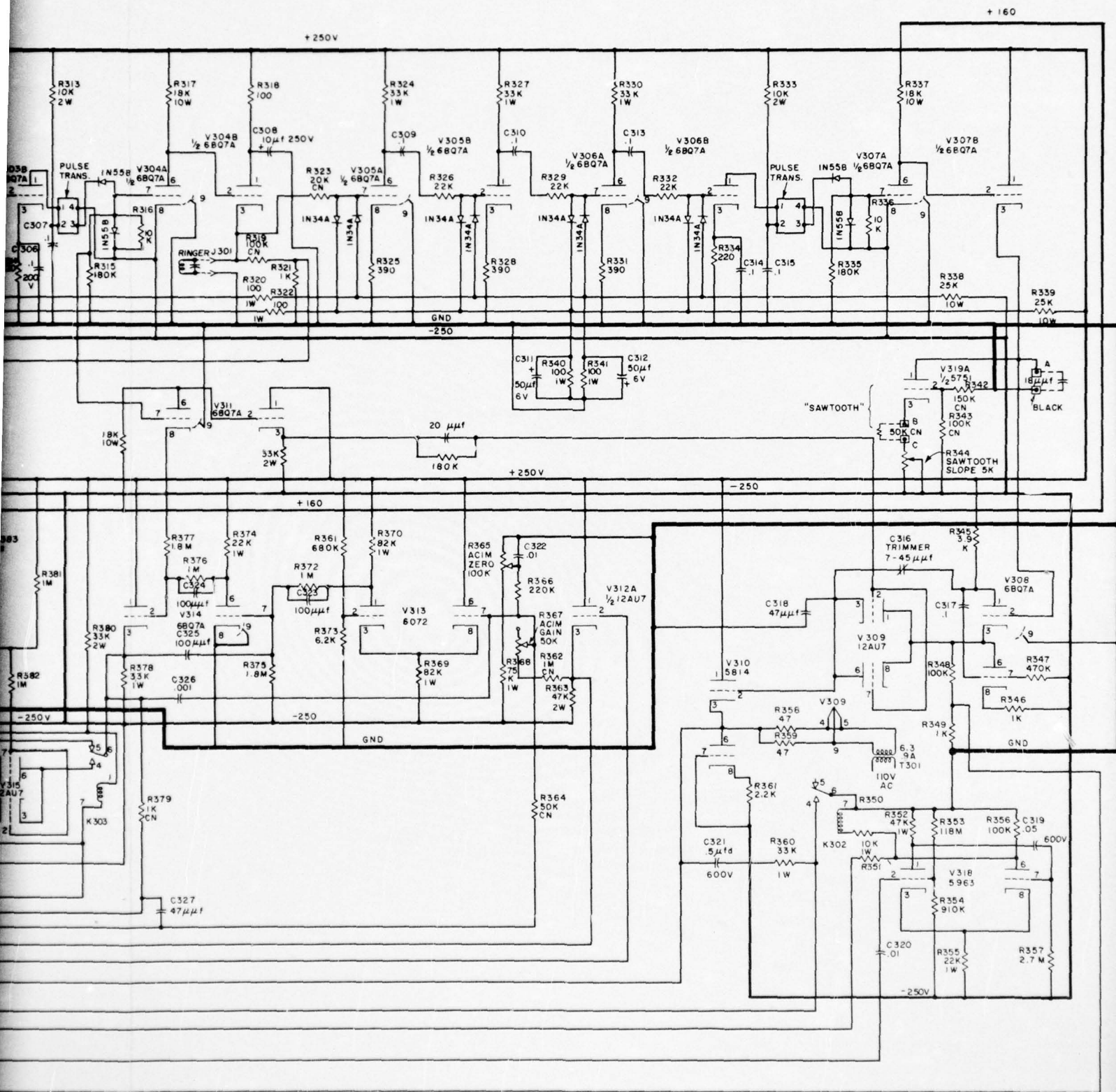

- NOTES:
1. CONDENSER VALUES IN μf UNLESS NOTED
 2. CONDENSER 400V UNLESS NOTED
 3. RESISTOR VALUES IN OHMS UNLESS NOTED
K = 1000 Ω
M = 1,000,000 Ω
 4. RESISTORS 1/2 WATT UNLESS NOTED
 5. CN DENOTES 1% LOW NOISE RESISTORS

SONAR SIGNAL ANALYZER
ACIM CHASSIS
FIGURE C-18

2

AD-A033 138

MASSACHUSETTS INST OF TECH CAMBRIDGE ACOUSTICS LAB
SONAR SIGNAL ANALYZER Q-4X.(U)
APR 58 G FARRELL

F/G 17/1

UNCLASSIFIED

NOBSR-64653

NL

2 OF 2
AD
A033138

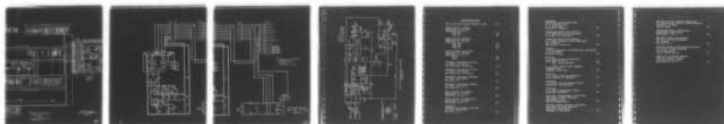

END

DATE
FILMED
2-77

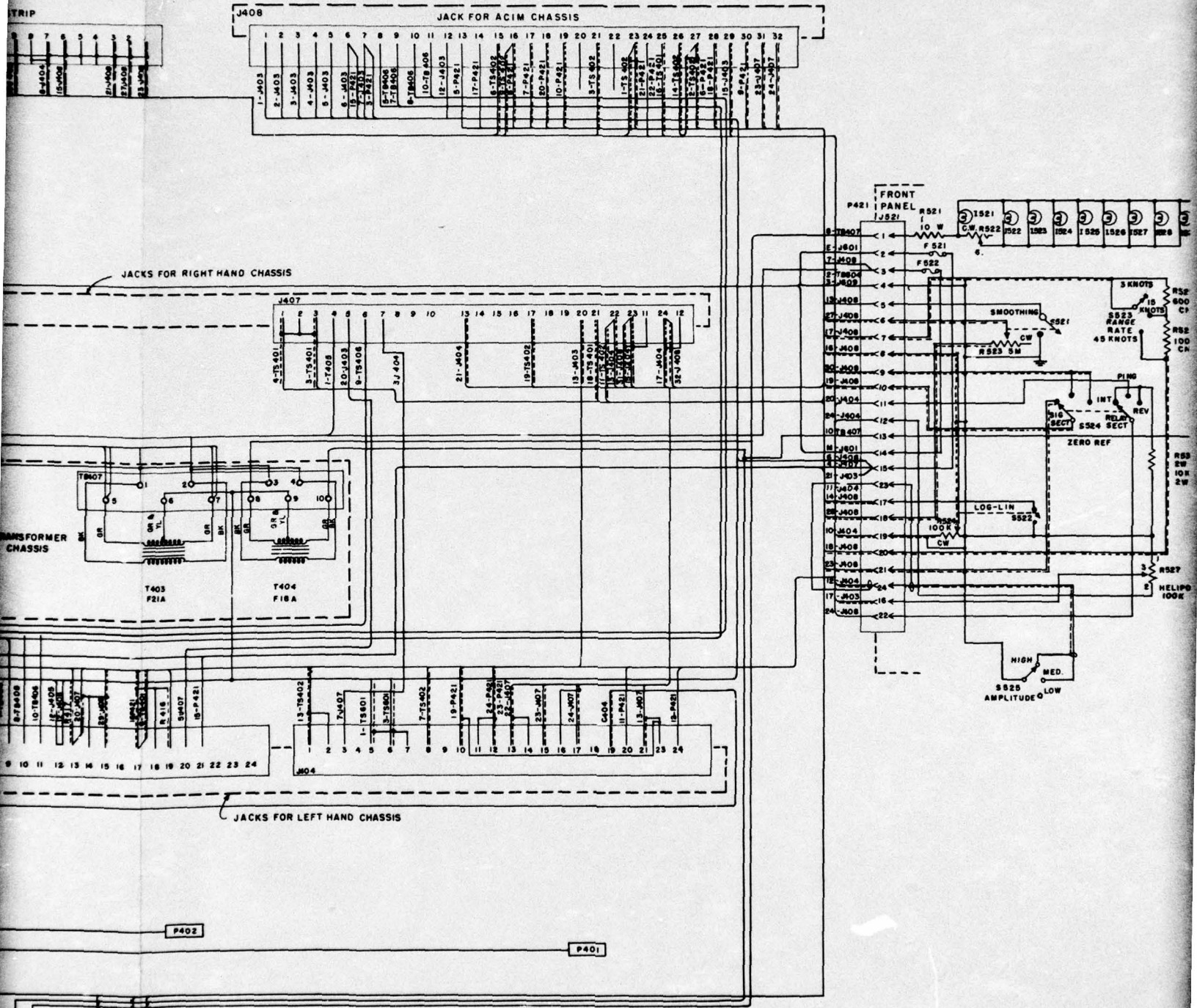

- NOTES:
1. CONDENSER VALUES IN μf UNLESS NOTED
 2. CONDENSER 400V UNLESS NOTED
 3. RESISTOR VALUES IN OHMS UNLESS NOTED
 K = 1000 Ω
 M = 1,000,000 Ω
 4. RESISTORS 1/2 WATT UNLESS NOTED
 5. CN DENOTES 1% LOW NOISE RESISTORS
 6. I DENOTES 6.3V LAMPS

SONAR SIGNAL ANALYZER
 FRAME AND INTERCONNECTIONS
 FIGURE C-19

2

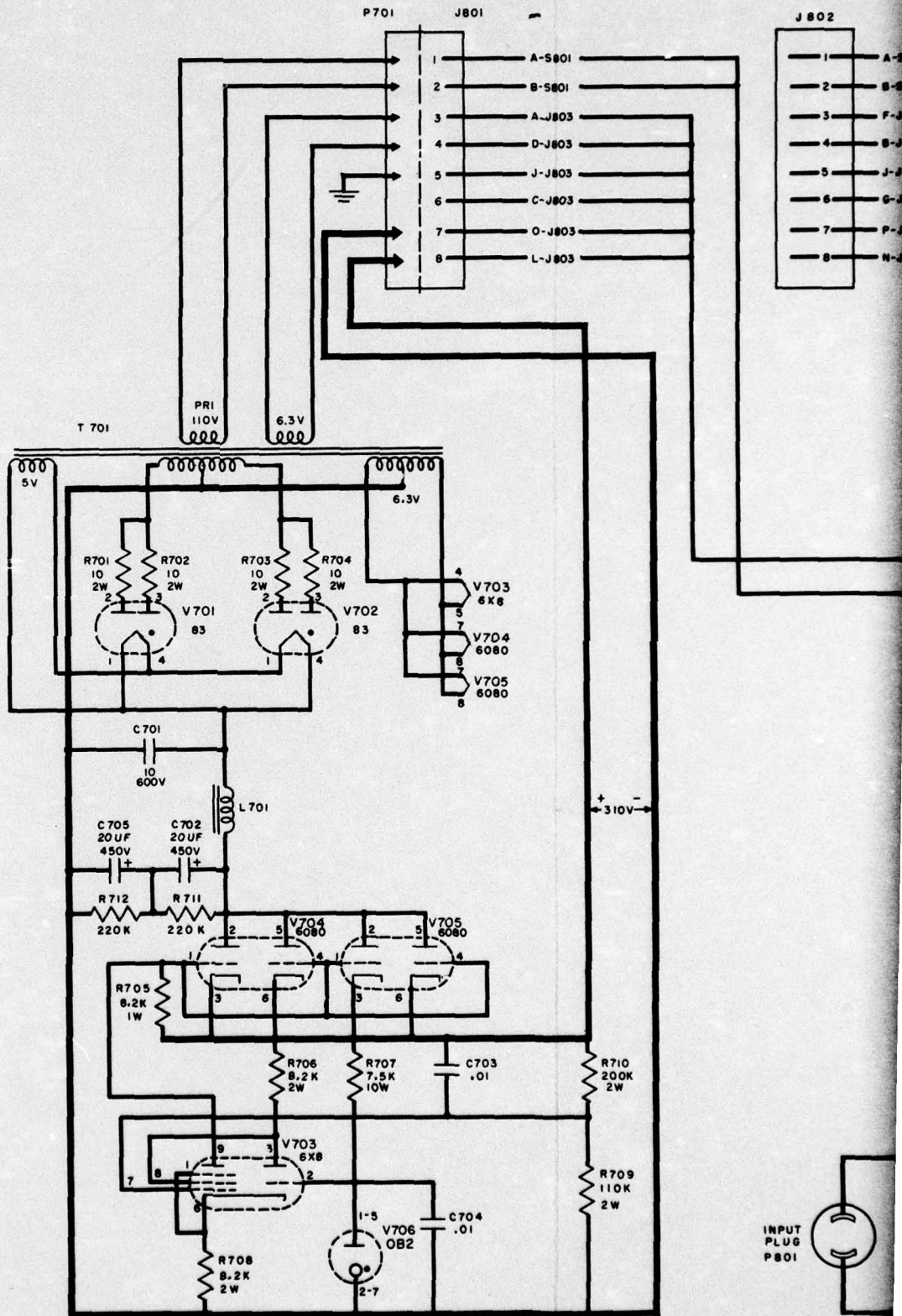

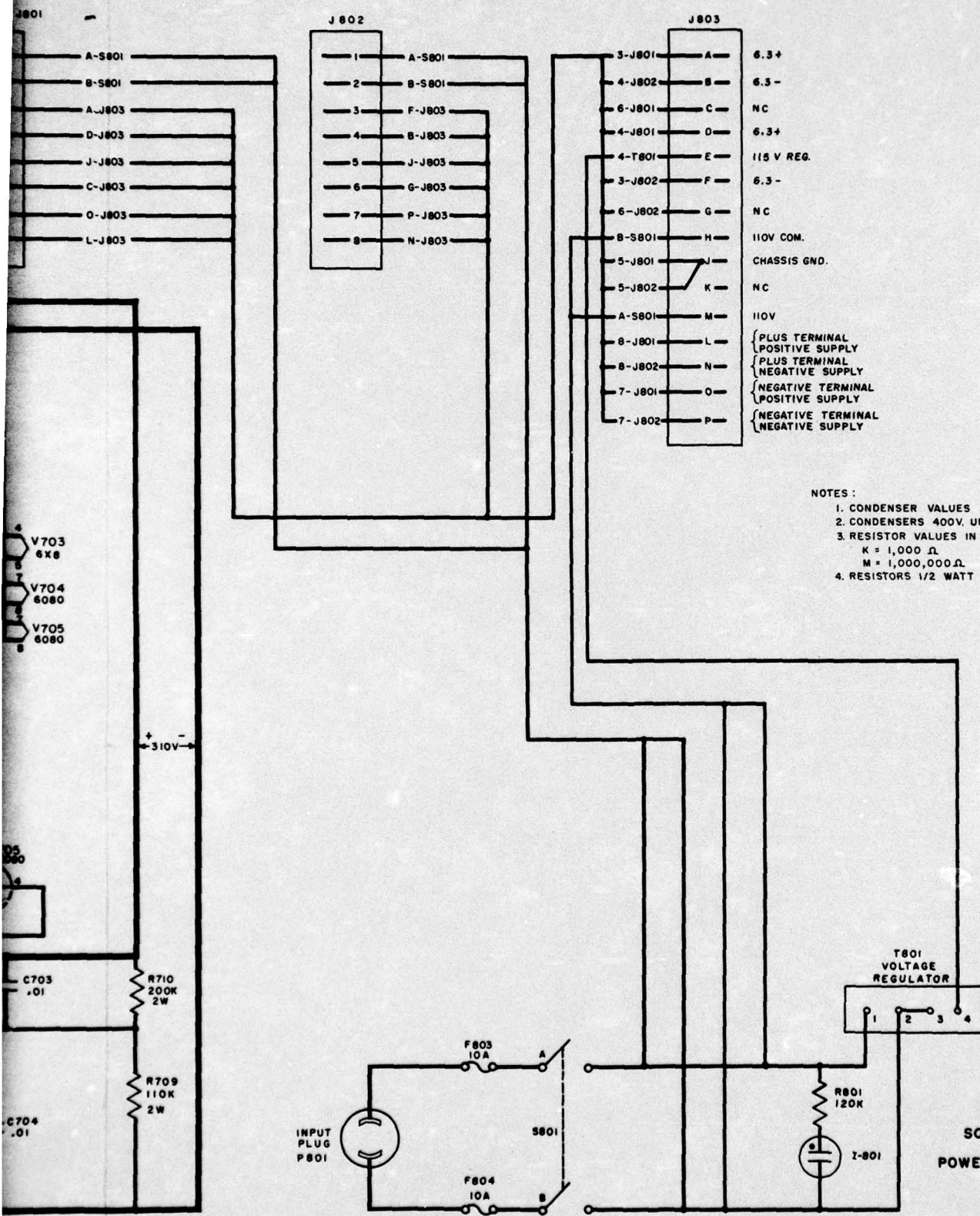

SONAR SIGNAL ANALYZER
POWER SUPPLY AND FRAME
FIGURE C-20

2

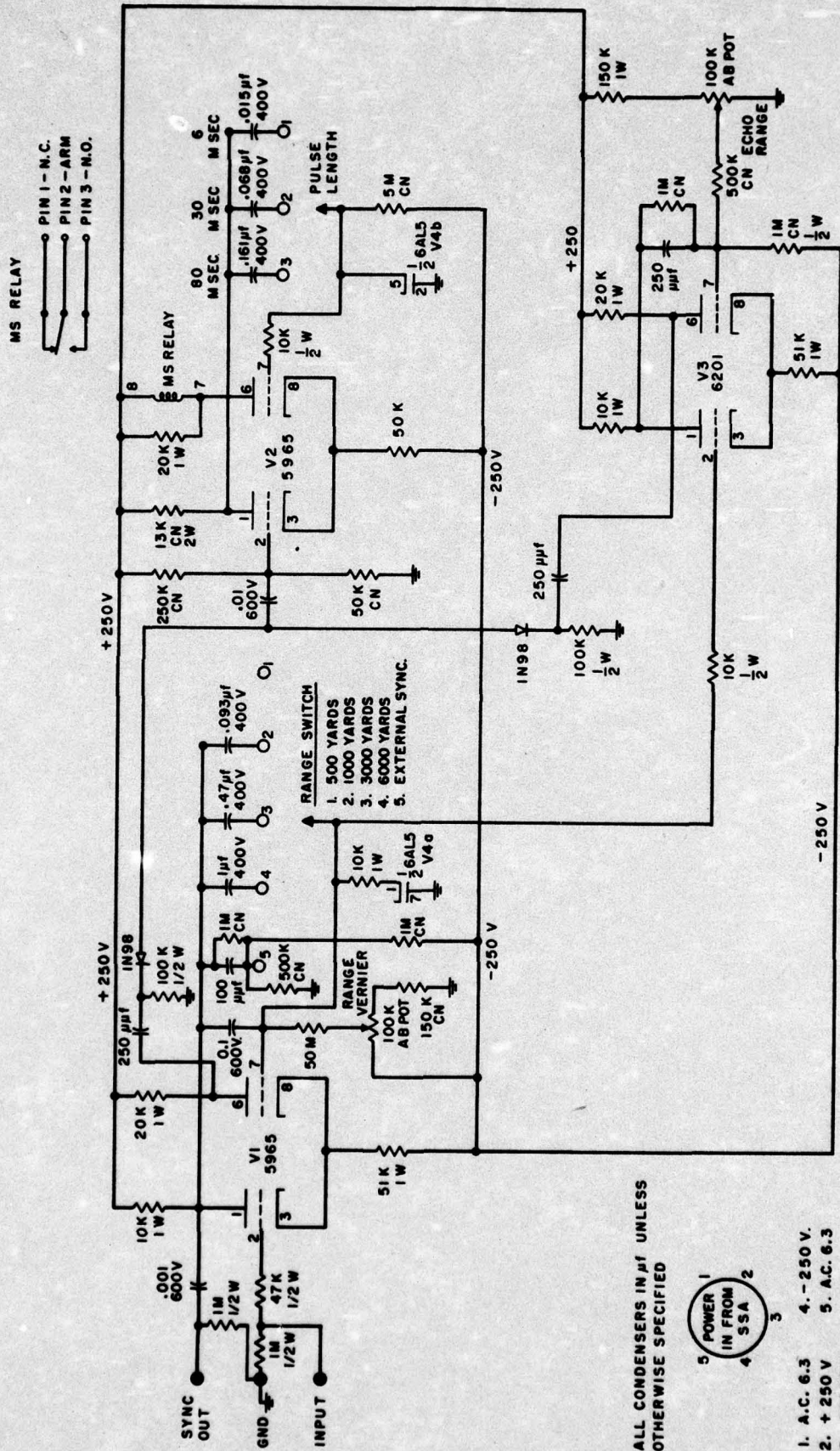

TEST UNIT FOR SONAR SIGNAL ANALYZER
FIGURE C-21

ALL CONDENSERS IN μF UNLESS OTHERWISE SPECIFIED



- 1. A.C. 6.3
- 2. + 250 V
- 3. GROUND
- 4. - 250 V
- 5. A.C. 6.3

Distribution List

With each Sonar Signal Analyzer, Q-4X (4)

Chief, Bureau of Ships
Department of the Navy
Washington 25, D. C.
Code 847 (2)
Code 312 (4)

Chief of Naval Research
Department of the Navy
Washington 25, D. C.
Code 466 (3)
Code 463 (1)
Code 411 (1)

Chief of Naval Operations
Department of the Navy
Washington 25, D. C.
Op-31 (2)
Op-37 (2)

Commander, Submarines Pacific
c/o Fleet Post Office
San Francisco, California (1)

Commander, Destroyers Pacific
c/o Fleet Post Office
San Francisco, California (1)

Commander, Submarines Atlantic
c/o Fleet Post Office
New York, N. Y. (1)

Commander, Destroyers Atlantic
c/o Fleet Post Office
New York, N. Y. (1)

Chief, Bureau of Ordnance
Department of the Navy
Washington 25, D. C. (2)

Chief, Bureau of Aeronautics
Department of the Navy
Washington 25, D. C. (2)

Commander
Submarine Development Group TWO
c/o Fleet Post Office
New York, N. Y. (1)

Commander
Operational Development Force
U. S. Atlantic Fleet
U. S. Naval Base
Norfolk 11, Virginia (1)

Commanding Officer and Director
U. S. Navy Electronics Laboratory
San Diego 52, California (3)

Commanding Officer and Director
U. S. Navy Underwater Sound Laboratory
Fort Trumbull
New London, Connecticut (3)

Director
U.S.Navy Underwater Sound Reference Laboratory
P. O. Box 3629
Orlando, Florida (2)

Director
U. S. Naval Research Laboratory
Washington 25, D. C. (2)
Att: Sound Division (1)

U. S. Naval Ordnance Test Station
Pasadena Annex
Pasadena, California (2)

Director
U. S. Naval Ordnance Laboratory
Silver Spring 19, Maryland (3)

Commander
U. S. Naval Air Development Center
Johnsville, Pennsylvania (1)

Librarian
U. S. Naval Postgraduate School
Monterey, California (1)

Woods Hole Oceanographic Institution
Via Office of Naval Research
495 Summer Street
Boston, Massachusetts (1)

Director, Marine Physical Laboratory
Via Office of Naval Research
1030 East Green Street
Pasadena 1, California (1)

Director, Defense Research Laboratory
Via Resident Rep.-Office of Naval Research
University of Texas
Austin, Texas (1)

Commanding Officer and Director
David Taylor Model Basin
Washington 7, D. C. (2)

Director, Hudson Laboratories
Via Office of Naval Research
346 Broadway
New York, N. Y. (1)

Research Analysis Group-Brown University
Via Office of Naval Research
495 Summer Street
Boston, Massachusetts (1)

Committee on Undersea Warfare
National Research Council
2101 Constitution Avenue
Washington 25, D. C. (1)