

AD-A033 191

TRI-CON ASSOCIATES INC CAMBRIDGE MASS  
DESIGN AND FABRICATION OF SATELLITE ELECTRON BEAM SYSTEM, (U)

F/G 22/2

AUG 76 W B HUBER  
C-140

F19628-75-C-0114

NL

UNCLASSIFIED

AFGL-TR-76-0184

1 of 1  
ADA033191



END

DATE  
FILMED  
2 - 77

ADA033191

AFGL-TR-76-0184

*Handwritten signature and circled number 12*

DESIGN AND FABRICATION OF SATELLITE  
ELECTRON BEAM SYSTEM

William B. Huber

TRI-CON ASSOCIATES, INC.  
765 Concord Avenue  
Cambridge, Massachusetts 02138

Scientific Report No. 1

1 August 1976

**DDC**  
**REGISTERED**  
DEC 7 1976  
**REGISTERED**  
*Handwritten signature*

Approved for public release; distribution unlimited

AIR FORCE GEOPHYSICS LABORATORY  
AIR FORCE SYSTEMS COMMAND  
UNITED STATES AIR FORCE  
HANSCOM AFB, MASSACHUSETTS 01731

**COPY AVAILABLE TO DDC DOES NOT  
PERMIT FULLY LEGIBLE PRODUCTION**

Qualified requestors may obtain additional copies from the Defense Documentation Center. All others should apply to the National Technical Information Service.

UNCLASSIFIED

SECURITY CLASSIFICATION OF THIS PAGE (When Data Entered)

19 REPORT DOCUMENTATION PAGE		READ INSTRUCTIONS BEFORE COMPLETING FORM
1. REPORT NUMBER 18 AFGL TR-76-0184	2. GOVT ACCESSION NO.	3. RECIPIENT'S CATALOG NUMBER
4. TITLE (and Subtitle) 6 DESIGN AND FABRICATION OF SATELLITE ELECTRON BEAM SYSTEM		5. TYPE OF REPORT & PERIOD COVERED Scientific Report No. 1
7. AUTHOR(s) 10 William B. Huber		6. PERFORMING ORG. REPORT NUMBER 14 C-140, Scientific-1
9. PERFORMING ORGANIZATION NAME AND ADDRESS TRI-CON ASSOCIATES, INC. 765 Concord Avenue Cambridge, Massachusetts 02138		8. CONTRACT OR GRANT NUMBER(s) 15 F19628-75-C-0114 new
11. CONTROLLING OFFICE NAME AND ADDRESS Air Force Geophysics Laboratory Hanscom AFB, Massachusetts 01731 Contract Monitor: Herbert A. Cohen/LKB		10. PROGRAM ELEMENT, PROJECT, TASK AREA & WORK UNIT NUMBERS 62101F 16 6690-01-03
14. MONITORING AGENCY NAME & ADDRESS (if different from Controlling Office) 13 35 p.		12. REPORT DATE 11 1 Aug 1976
16. DISTRIBUTION STATEMENT (of this Report) Approved for public release; distribution unlimited		13. NUMBER OF PAGES 35
17. DISTRIBUTION STATEMENT (of the abstract entered in Block 20, if different from Report)		15. SECURITY CLASS. (of this report) UNCLASSIFIED
18. SUPPLEMENTARY NOTES		15a. DECLASSIFICATION/DOWNGRADING SCHEDULE
19. KEY WORDS (Continue on reverse side if necessary and identify by block number) Satellite Electron Beam System		
20. ABSTRACT (Continue on reverse side if necessary and identify by block number) A satellite electron beam system was designed and fabricated using the Machlett Laboratories, Inc., Model EE-65 Electron Gun. The design accommodates six levels of beam current, six levels of beam energy, three focus anode levels as a percentage of beam energy, and operation in a pulsed mode synchronous with the space vehicle PCM system. over continued		

DD FORM 1 JAN 73 1473

EDITION OF 1 NOV 65 IS OBSOLETE

SECURITY CLASSIFICATION OF THIS PAGE (When Data Entered)

390 416

int

UNCLASSIFIED

SECURITY CLASSIFICATION OF THIS PAGE(When Data Entered)

All instrument operating modes are ground commandable with  
no automatic sequential modes of operation.

UNCLASSIFIED

SECURITY CLASSIFICATION OF THIS PAGE(When Data Entered)

TABLE OF CONTENTS

	Page
1. INTRODUCTION. . . . .	1
2. ELECTRON GUN DESCRIPTION. . . . .	1 - 3
3. DESIGN GOALS. . . . .	3 - 6
4. POWER SUPPLY DESIGN . . . . .	7 - 12
5. BEAM CURRENT LEVEL CONTROL. . . . .	12 - 14
6. RESTRICTION ON PERFORMANCE DUE TO DYNAMIC RANGE. . . . .	15 - 17
7. DESCRIPTION OF TELEMETRY INTERFACE CIRCUITS. . . . .	17 - 19

ACCESSION for	
NTIS	White Section <input checked="" type="checkbox"/>
BUD	Ball Section <input type="checkbox"/>
UNCLASSIFIED	<input type="checkbox"/>
RESTRICTED	<input type="checkbox"/>
BY	
DISTRIBUTION/AVAILABILITY CODES	
Dist.	AVAIL. & USE OF SPECIAL
A	

LIST OF TABLES

	Page
TABLE 1. . . . .	20
Beam Energy Command Relay States	
TABLE 2. . . . .	21
TLM Flag Outputs vs Command Status	
TABLE 3. . . . .	22
High Voltage Monitor Circuit Gain (Volts/Volt) vs Beam Energy & Focus Commands	
TABLE 4. . . . .	23
Beam Current Monitor Gains as a Function of Beam Current Commands	

LIST OF DRAWINGS

	Page
D-718 - Sheet 1. . . . .	24
Schematic - Electron Gun Power Supply-Board A	
D-718 - Sheet 2. . . . .	25
Schematic - Electron Gun Power Supply-Board B	
D-716. . . . .	26
Schematic - Beam Current Level And Duty Cycle Control Card	
D-717. . . . .	27
Schematic - TLM Amplifiers and Word Timing Logic	
D-715. . . . .	28
Assembly - Satellite Electron Beam System	
FIGURE 1. . . . .	29
Power Requirements vs Beam Control Command Setting	

## 1. INTRODUCTION

This report details the design of a satellite electron beam system. The system utilizes a Machlett Laboratories, Inc., Model EE65 electron gun which was designed for space-flight applications.

The contract specification call for six levels of electron beam energy, six levels of beam current, three focus anode voltage levels as a percentage of beam energy, and operation in a pulsed mode, synchronous with the spacecraft PCM telemetry system. All instrument operating modes are ground commandable using magnetic latching relays within the instrument. There are no automatic sequential modes of operation.

To prevent poisoning of the oxide-coated cathode at atmospheric pressure prior to spacecraft launch, the electron gun is opened in orbit upon ground command. The instrument is to be used on the SCATHA (Satellite charging at high altitudes) satellite.

## 2. ELECTRON GUN DESCRIPTION

The Machlett EE65 electron gun has a heater - cathode and control grid assembly which is basically that of a power triode. In addition it has a focusing anode, accelerating anode and an end cap or collector. The collector is used as a beam return circuit before the gun is opened.

In the original design of the EE65 there was a band of moly-manganese fired to the outside of a ceramic tube between the end cap and the accelerating anode ring. This band was two mils thick and about one-eighth inch wide. The cold resistance was about one-quarter ohm.

When sixteen volts from a suitable supply was applied to the band, the high current of about sixty amperes heat-stressed the ceramic cylinder causing it to crack evenly around the tube. The end cap was fixed to a spring loaded arm which carried the cap to the side of the gun assembly after the ceramic tube was cracked. In the process of opening the gun the moly-manganese band was open-circuited, shutting off the power drain from the supply. The gun opening required two to three seconds. This method of opening the EE65 electron gun was successfully tested many times and successfully used in sounding rocket instrumentation.

The minimum cell size for flight supplies to provide the sixty amperes was the Yardney HR-15 cell, rated at fifteen ampere-hours.

Since both the voltage and peak power levels are not readily attainable on a satellite, Machlett Laboratories changed the design of the ceramic tube between the accelerating anode ring and the end cap. The moly-manganese band was reduced to one mil thickness by approximately fifty thousandths wide.

This increased the cold resistance to approximately one ohm.

On the inside surface of the ceramic cylinder, directly under the moly-manganese band, a groove was machined to reduce the cylinder wall thickness. Successful tube breakings were made using twenty-eight volts at approximately twenty-five amperes for approximately three seconds.

In addition, a squib-actuated wedge mechanism was designed by W. Lynch of AFGL to separate the end cap from the ceramic cylinder at the brazed joint between the cylinder and the cap. This method of opening the gun was tested successfully many times on dummy guns at atmospheric pressure. The greatly reduced spacecraft power requirement of the squib-actuated wedge mechanism over the heat-stressed band is obviously desirable but the effect of out-gassing of the expended squib on cathode poisoning has not been fully investigated as of the writing of this report.

### 3. DESIGN GOALS

Because of the electron gun application as a stimulus for the SCATHA satellite, the design goals were:

- 1) as much beam current as possible within the restriction of fifty watts maximum with the instrument, and
- 2) as much dynamic range both in beam current and energy as possible.

The first goal depends upon the electron tube geometry and operating conditions. The EE65 electron gun is capable of forming a beam with a current of seventy-five milliamperes at ten kilovolts of accelerating potential. At low energies the beam is poorly defined and a significant amount of power is expended in the anode ring.

End cap and anode ring characteristic curves were plotted for two EE65 electron guns (S/N 384 & 394) in the 500 volt to 3000 volt region. Assuming that twenty watts of beam power requires fifty watts of input power to the instrument, maximum beam current (cap current) at less than twenty watts beam power occurs at an energy level of 1500 volts. At this voltage the cap current is 13 milliamperes. The anode ring current is 4 milliamperes. The control grid draws about 5 ma.

Variation in focus voltage up to ten percent of the accelerating voltage has little effect on the cap current but a large effect on anode ring current in the accelerating voltage range of 500 volts to 3 kv. However, the anode ring current is minimum at a focus anode voltage approximately 1 to 5% of the accelerating voltage and increases with focus anode voltage.

All of the tube characteristic curves were taken at a filament power level of 7.5 volts at 0.9 amperes. Spot checks of the curves at the nominal heater power of 6.3 volts at 0.75 amperes produced similar data.

Further tests were performed down to accelerating voltages of fifty volts to try to determine if a significant beam current could be generated at low energy levels. It was found that beam currents of one milliampere were possible down to energies of one hundred and fifty volts, and beam current of one hundred micro-amperes down to energies of fifty volts.

At the maximum beam current for fifty watts of input power, the power breakdown for a flight instrument is as follows:

Beam Power	19.5 watts
Heater Power	7.5 "
Anode Ring Power	6.0 "
Instrument Control Power	<u>5.0 "</u>
	38.0 watts

Assumed 75% efficiency

50.6 watts input power

Arbitrarily assigning three kilovolts as an upper boundary on accelerating potential, the maximum beam current at this potential in a non-pulsed mode of operation is six milliamperes.

The design goals re-defined with the constraints of maximum beam current at no more than fifty watts input, maximum beam energy of three kilovolts, and a maximum dynamic range are: 6 levels of electron energy: 3 kv, 1.5 kv, 500 V, 300 V, 150 V, 50 V. 6 levels of beam current: 13 ma,

6 ma, 1 ma, .1 ma, .01 ma, .001 ma. The above two parameters to be commandable in any combination. However, the combination of three kilovolts at thirteen milliamperes exceeds the maximum input power level and must be automatically locked out of the command circuits. The combinations of low energy and high currents are not possible due to the electron tube geometry, but, cannot exceed the input power maximum.

In addition to the two six-level functions described above, it is desirable to set one of three possible focus voltages by ground command. Best focus values are 0%, 5%, and 10% of the accelerating potential as determined by least anode ring current for maximum beam current.

Since any space vehicle PCM system can supply PCM word gates of a wide variety of frame word lengths or word bit lengths, it is desirable to operate the electron beams system in a pulsed mode producing another factor of ten or so in average beam current dynamic range as well as provide a dynamic stimulus for the analysis of spacecraft charging phenomena at high altitudes. It was decided to use a duty cycle of one-sixteenth (6.25%).

For a frame length of 128 words and 8 frames per second, a timing gate of 4 words per frame, twice per frame, produces a beam pulse of 3.9 milliseconds and a pulse repetition rate of 16 per second.

#### 4. POWER SUPPLY DESIGN

The schematic diagrams for the electron beam system power supply is shown on Drawing D-718, Sheets 1 and 2.

On Sheet 1, the input power lines contain a filter composed of C101, L101, and C102 to reduce conducted emissions from the power supply switching regulators and power inverters. The output of the filter powers two switching regulators, D101 and D102. D101 with its pass transistor switch circuit Q101 and Q102, storage inductance, L102 commutating diode, CR102 and output filter, C103 and C104, produces a fixed twenty volt regulated output which supplies power for the master inverter oscillator Q201, Q202 and T202 on Sheet 2 and slave power inverter Q105, Q106 and T102.

D102 with its pass transistor switch circuit, Q103 and Q104, energy storage inductance, L103, commutating diode, CR103 and output filter, C110 and C111, produces a four level regulated output voltage, programmed by command relays, K101 and K102.

The master oscillator is a low power, ferrite core, transformer type designed to free-run at twenty Khz. It is synchronized by the presence of a twenty-five Khz signal from the space vehicle system on the primary of T201. The transformer isolates power ground from the signal ground return of the synchronizing signal.

The secondary winding, 7-9 of the master oscillator transformer provides a boot strapped three and one-half volt supply on top of the input twenty-eight volts so that both switching regulator pass transistors may be bottomed at low input line voltage and therefore maintain high switching efficiency.

Windings 10-12 and 13-15 provide base switching signals for both power inverters. Dither signals for both switching regulators are taken from the collectors of the master oscillator switching transistors. Note that these signals are presented to the switching regulators on alternate half cycles of the oscillator. Therefore, the switching regulators and the power inverters are all synchronized to the master oscillator.

The power inverters are non-saturating ferrite core type. The slave power inverter consisting of Q105, Q106 and T102, provide the fixed power supply voltages for the electron beam system. Winding 4-6 of T102 provides +5 volts referred to ground for the TTL logic in the input timing gate circuits. Winding 7-9 provides +15 volts referenced to ground for the telemetry buffer amplifiers and other analog circuits referenced to ground. These voltages are post-regulated by D103 and D104.

Winding 13-15 provide square-wave heater power for the electron gun. This winding floats at the negative high voltage of the beam energy power supply.

Winding 10-12 provide the square-wave power to rectifiers CR220 and filters C214 and 215 producing +35 volts referred to the negative high voltage of the beam energy power supply.

Transformer assembly T101 is a five toroid assembly. Sections A and B with their respective diode bridge assemblies, CR209 and CR210, develop 750 volts each with 20 volts on the center taps of their primaries. Sections C, D and E and their respective bridge rectifiers CR211, CR212 and CR213, develop 500 volts each with 20 volts on the center taps of their primaries.

The five secondary voltage outputs are wired in series to form the beam energy high voltage supply. The primaries of section A and B of T101 are driven by inverter transistors Q105 and Q106 through command relay K103 in the 3 Kv command mode only. The primaries of sections C and D are driven by transistors Q107 and Q108 through command relay, K104, in the 3 Kv and 1.5 Kv command modes only. The primary of section E is always driven by transistors Q107 and Q108. In the 3 Kv, 1.5 Kv and 500 V modes the primary center taps of the transformer are at 20 volts. In the 300 V, 150 V and 50 V modes the center tap of section E is reduced to approximately 12, 6 and 2 volts respectively by changing the feedback divider for switching regulator U102 with relays K101 and K102.

Those secondary supplies that are in the off state in other than the 3 Kv mode of operation look like short circuits due to the forward biasing of the rectifier diodes.

U105 is the diode matrix which determines the states of relays K101 through K104. Table I shows the relay states, sections of T101 energized, and output voltage of programmed switching regulator, U102, as a function of input command signal. Note that the sections of T101 which are powered are a function of K103 and K104 and the programmed regulator voltage is a function of K101 and K102.

Five volt command verification flags are generated which monitor the states of the beam energy relays. F10 and F11 are generated from five volt windings on T101, sections C and E, which are referred to signal ground. When the transformer sections are energized, the 25 Khz signal is half-wave rectified and filtered to produce five volts or a "one" to the PCM system. When the transformer section is not energized, it represents a very low impedance to ground and the negative fifteen volt return of the flag circuit load resistor keeps the rectifier on and produces a negative 0.6 volts or zero to the PCM system. This method of flag generation is required since both available poles of the relays being monitored, K103 and K104, are used.

Flags F12 and F13 monitor the status of K101 and K102. These flags are generated from the logic power supply voltage of +5 volts and are picked off the unused poles of the relays.

The states of the four beam energy level flags as a function of input commands is shown on Table II, F10 through F13.

On sheet two of the power supply schematic, a high impedance divider R212 through R229 is shown across the beam energy supply. This provides taps at the high end of the divider for voltage levels for the focus anode of the electron gun. A tap at the low end is used to develop an analog monitor voltage of the high voltage supply. The bottom end of the divider is established at a virtual ground by means of the beam current control amplifier, to be described later. The divider return current is not measured by this amplifier and therefore does not introduce an error in the control. U201 is a very high impedance unity gain amplifier to buffer the divider monitor. U201 is an inverting amplifier with gain switch as a function of beam energy command. When K101 or K102 or both are set (300 V, 150 V or 50 V command), Q203 is turned on and relay, K203 is closed, shorting out R234, increasing the gain by a factor of approximately ten. The focus relays change the resistor divider at the top of the monitor string of resistors, changing the overall gain of the high voltage monitor slightly.

Table III shows the variation of the high voltage monitor circuit with beam energy and focus commands.

The gun focus anode voltages are approximately 0%, 5% and 10% of the beam energy supply, tapped down from the negative high voltage. The focus switches are small reed relays, K201 and K202 capable of 3 kv isolation between their contacts and their energizing coils. The coils are driven by contacts from command latching relays, K204 and K205. The diode matrix for the three focus commands are CR227 through CR232.

The electron gun accelerating anode is returned to the positive end of the high voltage supply which is at a virtual ground.

#### 5. BEAM CURRENT LEVEL CONTROL

The floating electron gun cathode and grid driver circuit is shown on Schematic D-718, Sheet 2. The other elements of the beam current control loop are shown on Schematic D-716, "Beam Current Level and Duty Cycle Control Card."

U301 is a current to voltage amplifier with command switched gain. Relays K303 through K307 are set, one at a time by means of commands on the six current level command lines, through

diode matrices U303 and U304. R325 is across the amplifier at all times. In the one micro-ampere command mode, none of the five relays is set. In each of the higher current command modes one of the relays is set while all others are reset. This places an additional resistor in parallel with R325, changing the gain of the trans-resistance amplifier.

When the beam is on, the high voltage return current, either through the cap and logarithmic amplifier (to be explained later) or through the open gun and the environment to the space vehicle frame, must all pass through the feedback resistance of the amplifier, U301. The amplifier maintains its input at the reference voltage of pin 3 or zero volts. A positive current into the amplifier forces the output at pin 6 negative until the reference voltage of CRL, 6.4 volts, is reached. At this point Q301 starts to turn off, reducing the current to the photodiode of optoisolator, U204, on Schematic D-718.

This in turn reduces the current through the grounded base amplifier, Q204, and causes the output of amplifier U203 to go negative, shutting off the electron gun.

The control loop then is such that the output of trans-resistance amplifier U301 goes to -6.4 volts by adjusting the beam current of the EE-65 electron gun. The electron gun current is therefore 6.4 volts divided by the resistance placed across U301.

The six commandable levels are: .001 ma, .01 ma, .1 ma, 1 ma, 6 ma, and 13 ma. Q302 is normally off when the command relay K301 is reset (100% Duty Cycle) and K302 is set (Beam On). However, if F11 is high (3 kv command) and  $\bar{E}$  is high (13 ma command) along with F7 (100% Duty Cycle), the condition is detected at pins 1, 2, and 13 on U302, turning on Q302 and shutting off Q301 and ultimately the electron beam. This is the one possible command mode that requires in excess of fifty watts of input power.

6. RESTRICTION ON PERFORMANCE DUE TO DYNAMIC RANGE

Because of the great dynamic range goals in both beam energy levels and beam current levels, certain compromises had to be made. The loop gain of the current control loop would change by 13,000 to one unless some means of compensating the gain change of the transresistance amplifier, U301, is made. Additional relays in order to reduce the loop gain as the beam current level became large were considered and rejected because of weight and volume restrictions. A variable impedance electron gun cathode circuit was used. CR221 through CR226 and R239 through R244 form this variable impedance circuit. As more beam current (or cathode current) is drawn, the voltage across R239 increases, causing more of the diodes to conduct and placing lower impedances across R239. This effectively changes the gain of the electron gun by a factor of one to five thousand from beam currents of one microampere to thirteen milliamperes.

At a beam current of one microampere a few microvolts change between grid and cathode is sufficient to turn the gun off. Accordingly, the beam current at one microampere is one hundred percent modulated by noise, both random and power supply ripple. The lag time constant

in the transresistance amplifier to stabilize the loop at this high gain is in the order of ten milliseconds, and therefore the beam cannot be pulsed at the four millisecond pulse width at this current level.

The power supply noise at the higher beam potentials is higher. Over the complete range of beam potentials the one microampere can be controlled only to within  $\pm$  30 percent.

Even at the ten microampere level the lag time constant in the transresistance amplifier required to stabilize the loop is in the order of one millisecond and the beam pulse is not a faithful reproduction of the square driving pulse. The 100 percent duty cycle control is good to within 5 percent.

At the lowest beam energy level of fifty volts, the gun geometry does not allow control of beam currents above 100 microamperes. At 150 and 300 volts the current cannot be controlled above one milliampere. At 500 volts the current cannot be controlled above six milliamperes.

At the low beam energies the cathode potential with respect to signal ground (beam potential) is a function of beam current because of the variable cathode impedance. The energy level at the fifty volt command mode can vary between 55 volts and 45 volts from one microampere to

one hundred microamperes. The actual change in volts as a function of beam current remains approximately the same for each energy level but the percent variation from nominal energy level decreases as the high voltage level is increased.

## 7. DESCRIPTION OF TELEMETRY INTERFACE CIRCUITS

Schematic D-717 shows the space vehicle interface circuits for the instrument analog outputs and the timing gate input.

U7 is a buffer amplifier with a gain of  $-0.62$  with its reference at ground. This samples the output of the transresistance amplifier which goes negative with beam return current. Since the transresistance amplifier gain changes with beam current commands, Table 4 lists the overall gain from beam return current to telemetry output.

U8, U9, and Q1 form a unipolar logarithmic amplifier which is used to measure the electron gun cap current prior to cap removal.

The transfer characteristic of the amplifier is  $E_{TLM} = \log_{10} I_i + 6$ , where  $I_i$  is in amperes.

The cap current is passed through the logarithmic element to the amplifier power supply and on to the transresistance amplifier for linear measurement and beam current control.

U10 is a temperature monitor. The thermistor (T) is located on a printed circuit card retainer wall at the center of the assembly near the top plate. This is physically close to the electron gun socket where heater power of 4.75 watts is continuously expended when the instrument is on. The transfer characteristic of this circuit is:

$$T(^{\circ}\text{C}) = \frac{1}{A+B \ln R_t + C (\ln R_t)^2} \quad 3 - 273$$

where

$$R_t = \frac{3.78 E_{\text{TLM}} + 5.67}{6.49 - E_{\text{TLM}}} \times 10^3 \text{ ohms}$$

and

$$\begin{aligned} A &= 1.276 \times 10^{-3} \\ B &= 2.380 \times 10^{-4} \\ C &= 8.575 \times 10^{-8} \end{aligned}$$

This produces temperature measurements from 0<sup>o</sup>C to 70<sup>o</sup>C where +5V is equivalent to 0<sup>o</sup>C, and 0V is equivalent to +70<sup>o</sup>C.

Resistor dividers R22 - R23 and R24 - R25 provide monitors for the low voltage power supplies for diagnostic purposes in the case of flight data anomalies.

U1 is a Schmitt trigger input buffer for the beam pulse gating signal and the power supply synchronizing square wave of 25 KHz.

S1 is a monitor microswitch located on the gun break seal mechanism to monitor the deployment of the electron gun cap.

Table 2 is a list of discrete flags used to verify commands and gun cap deployment. Figure 1 is a graph of input power requirements versus the beam energy and current command settings.

COMMAND	RELAY STATES				SECTIONS OF		U102
	K101	K102	K103	K104	T101	REGULATOR	OUTPUT
					ON		
3 KV	Reset	Reset	Set	Set	A, B, C, D, E	20 Volts	
1.5 KV	Reset	Reset	Reset	Set	A, B, C	20 V	
.5 KV	Reset	Reset	Reset	Reset	A	20 V	
.3 KV	Set	Reset	Reset	Reset	A	12 V	
.15 KV	Reset	Set	Reset	Reset	A	6 V	
.05 KV	Set	Set	Reset	Reset	A	2 V	

TABLE 1  
BEAM ENERGY COMMAND RELAY STATES

TABLE 1

TLM FLAG OUTPUTS VS COMMAND STATUS

	F1	F2	F3	F4	F5	F6	F7	F8	F9	F10	F11	F12	F13	F14
<u>BEAM CURRENT LEVEL</u>	0	1	1	1	1	-	-	-	-	-	-	-	-	-
13 ma														
6	1	0	1	1	1	-	-	-	-	-	-	-	-	-
1	1	1	0	1	1	-	-	-	-	-	-	-	-	-
.1	1	1	1	0	1	-	-	-	-	-	-	-	-	-
.01	1	1	1	1	0	-	-	-	-	-	-	-	-	-
.001	1	1	1	1	1	-	-	-	-	-	-	-	-	-
BEAM ON	-	-	-	-	-	1	-	-	-	-	-	-	-	-
BEAM OFF	-	-	-	-	-	0	-	-	-	-	-	-	-	-
BEAM DUTY CYCLE	-	-	-	-	-	-	1	-	-	-	-	-	-	-
100%							0							
6.25%														
FOCUS	-	-	-	-	-	-	-	0	0	-	-	-	-	-
HI	-	-	-	-	-	-	-	1	0	-	-	-	-	-
MED	-	-	-	-	-	-	-	0	1	-	-	-	-	-
LC	-	-	-	-	-	-	-	0	1	-	-	-	-	-
<u>BEAM ENERGY LEVEL</u>	-	-	-	-	-	-	-	-	-	-	-	-	-	-
3KV	-	-	-	-	-	-	-	-	-	1	0	0	0	-
1.5	-	-	-	-	-	-	-	-	-	1	0	0	0	-
.5	-	-	-	-	-	-	-	-	-	0	0	1	0	-
.3	-	-	-	-	-	-	-	-	-	0	0	0	1	-
.15	-	-	-	-	-	-	-	-	-	0	0	1	1	-
.05	-	-	-	-	-	-	-	-	-	0	0	1	1	-
GUN CAP IN PLACE	-	-	-	-	-	-	-	-	-	-	-	-	-	1
GUN CAP DEPLOYED	-	-	-	-	-	-	-	-	-	-	-	-	-	0

<u>HIGH</u> <u>BEAM ENERGY</u>		<u>LOW</u> <u>BEAM ENERGY</u>	
(3 KV, 1.5 KV, 015 KV)		(300 V, 150 V, 50 V)	
Low Focus	- .00146	-	.0149
Med. Focus	- .00139	-	.0143
High Focus	- .00133	-	.0136

HIGH VOLTAGE MONITOR CIRCUIT GAIN (VOLTS/VOLT)  
VERSUS BEAM ENERGY & FOCUS COMMANDS

NOTE: Above values do not take into account the effect of focus anode current at low accelerating voltages. Focus anode current tends to make the High Focus gain increase toward the Low Focus value.

TABLE 3

<u>BEAM CURRENT COMMAND</u>	<u>TRANSRESISTANCE AMPLIFIER GAIN (FEEDBACK RESISTANCE)</u>	<u>X.62 (SIGNAL CONDITIONER) AMPLIFIER GAIN</u>
.001 ma	6.8 meg.	$4.22 \times 10^6$ volts/amp
.01 "	647K	$4.01 \times 10^5$ "
.1 "	63.4K	$3.92 \times 10^4$ "
1.0 "	6.34K	$3.92 \times 10^3$ "
6.0 "	1.05K	$6.51 \times 10^2$ "
13.0 "	.499K	$3.09 \times 10^2$ "

TABLE 4

BEAM CURRENT MONITOR GAINS  
AS A FUNCTION OF BEAM CURRENT COMMANDS



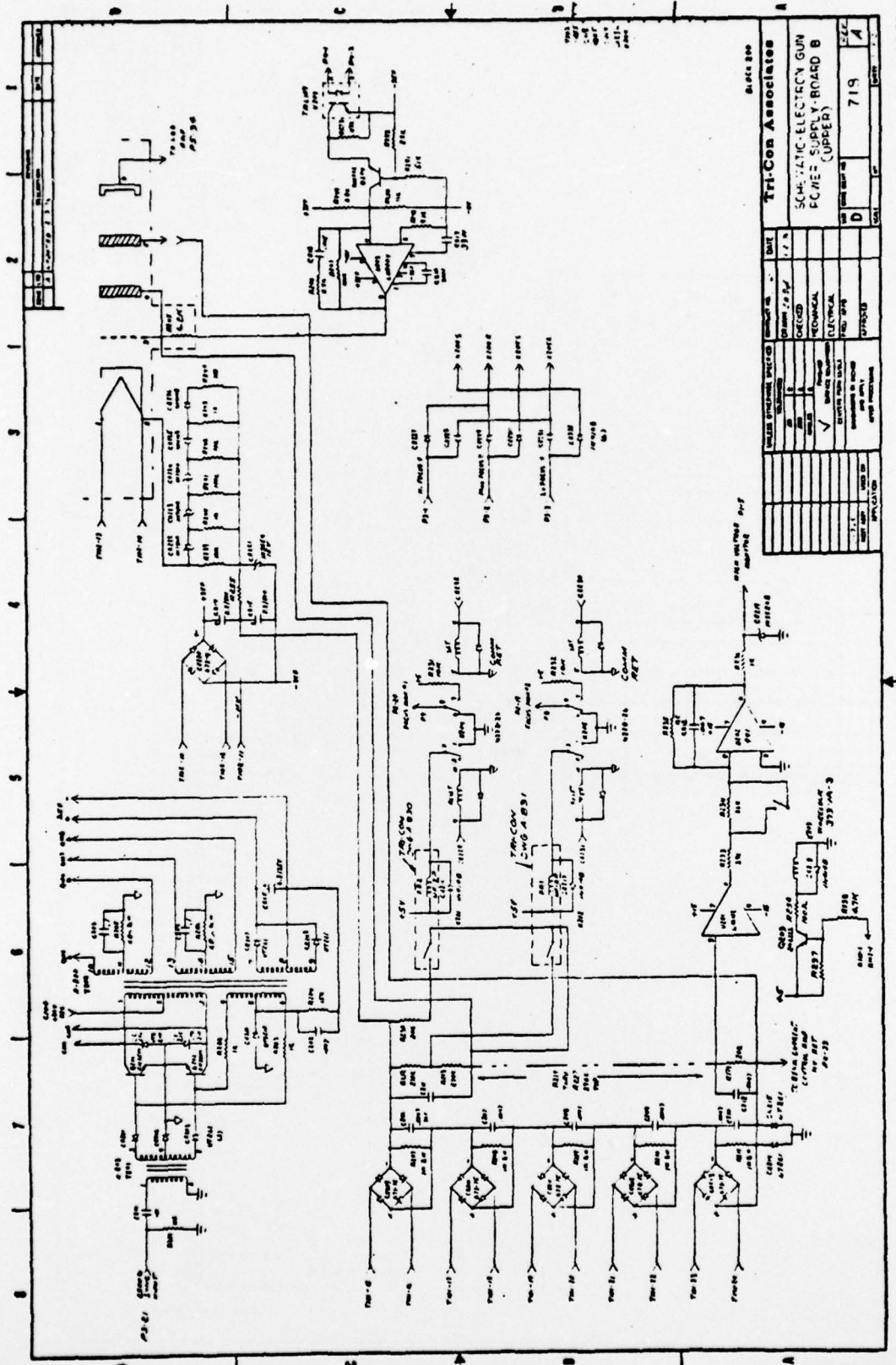

Block 810

Tri-Con Associates	
DATE	11-7-73
DESIGNED BY	W. J. ...
CHECKED BY	...
APPROVED BY	...
REVISIONS	...
REV	DESCRIPTION
1	...
2	...
3	...
4	...
5	...
6	...
7	...
8	...
9	...
10	...
11	...
12	...
13	...
14	...
15	...
16	...
17	...
18	...
19	...
20	...
21	...
22	...
23	...
24	...
25	...
26	...
27	...
28	...
29	...
30	...
31	...
32	...
33	...
34	...
35	...
36	...
37	...
38	...
39	...
40	...
41	...
42	...
43	...
44	...
45	...
46	...
47	...
48	...
49	...
50	...
51	...
52	...
53	...
54	...
55	...
56	...
57	...
58	...
59	...
60	...
61	...
62	...
63	...
64	...
65	...
66	...
67	...
68	...
69	...
70	...
71	...
72	...
73	...
74	...
75	...
76	...
77	...
78	...
79	...
80	...
81	...
82	...
83	...
84	...
85	...
86	...
87	...
88	...
89	...
90	...
91	...
92	...
93	...
94	...
95	...
96	...
97	...
98	...
99	...
100	...





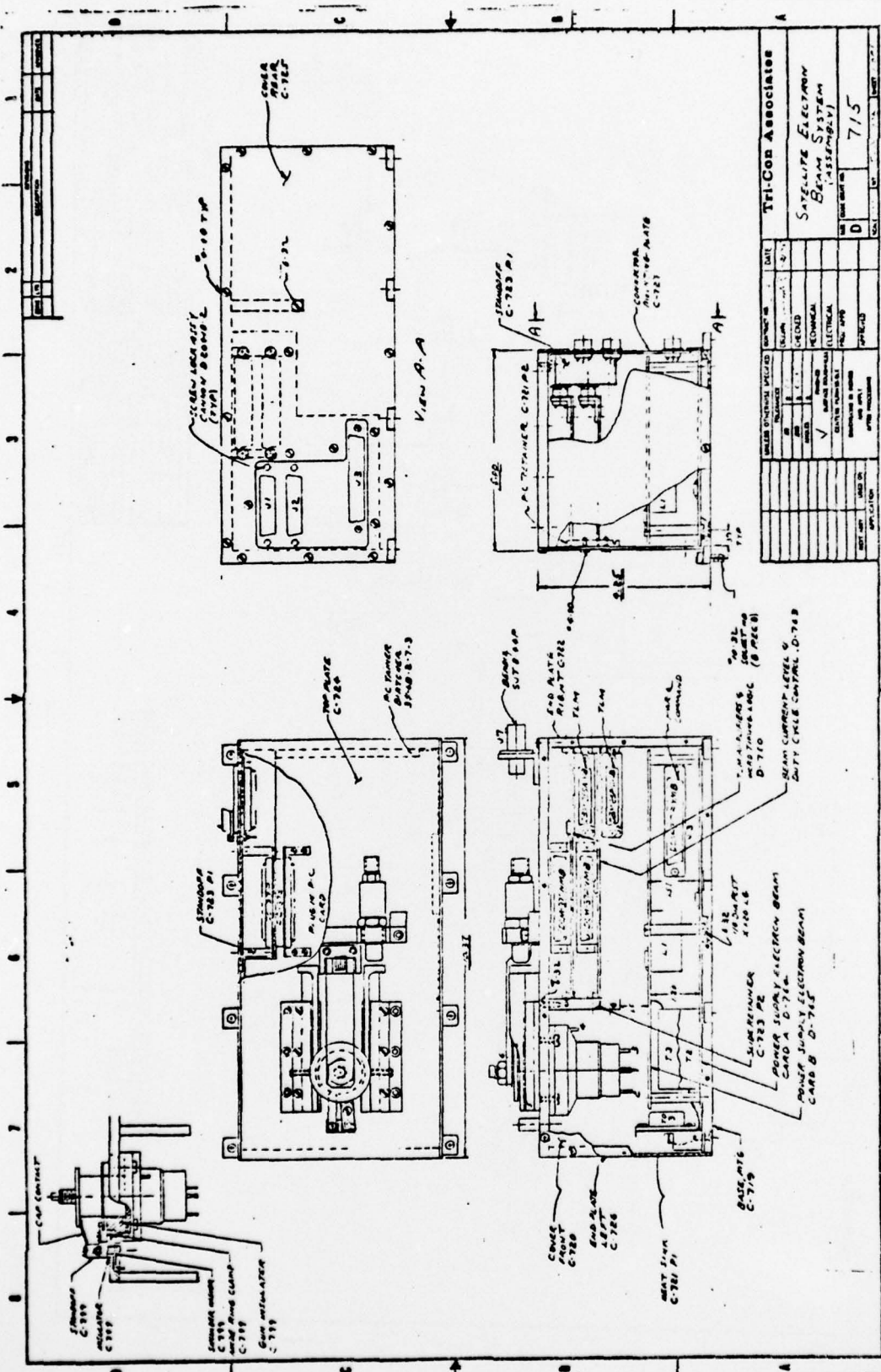

DATE		DRAWN BY		CHECKED BY		APPROVED BY	
<b>TRICOR ASSOCIATES</b> SATELLITE ELECTRON BEAM SYSTEM (ASSEMBLY)				D 715			

SCATHA SC 4-1 POWER REQUIREMENTS vs BEAM CONTROL COMMAND SETTING

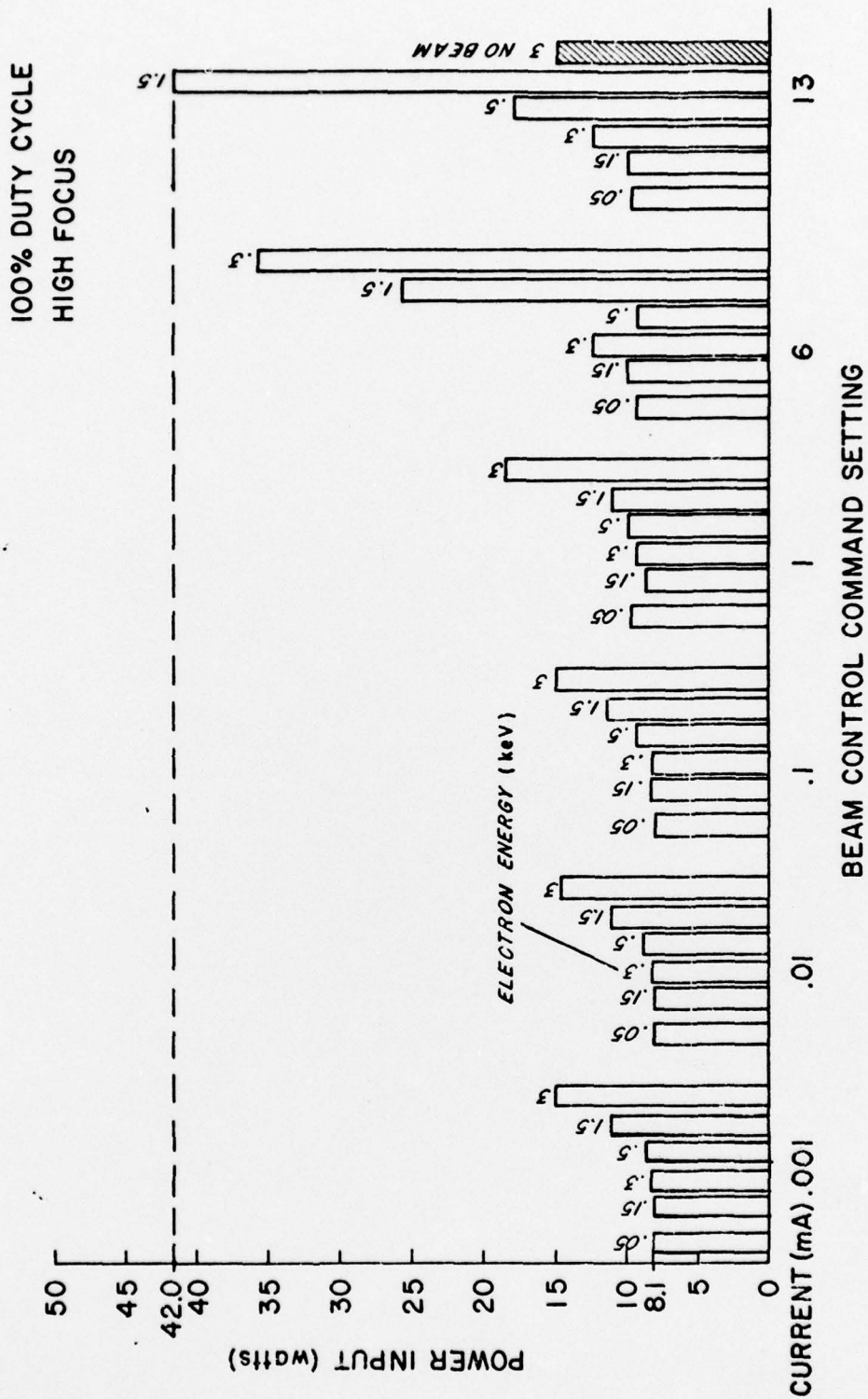

Figure 1