

AD-A033 263

NAVAL OCEANOGRAPHIC OFFICE WASHINGTON D C MARINE SC--ETC F/G 20/1
NORMAL INCIDENCE BOTTOM REFLECTION MEASUREMENTS IN THE TONGUE O--ETC(U)
JUN 64 D A ATKOCIUS

UNCLASSIFIED

NOO-IM-0-13-64

NL

| OF |

AD
A033263

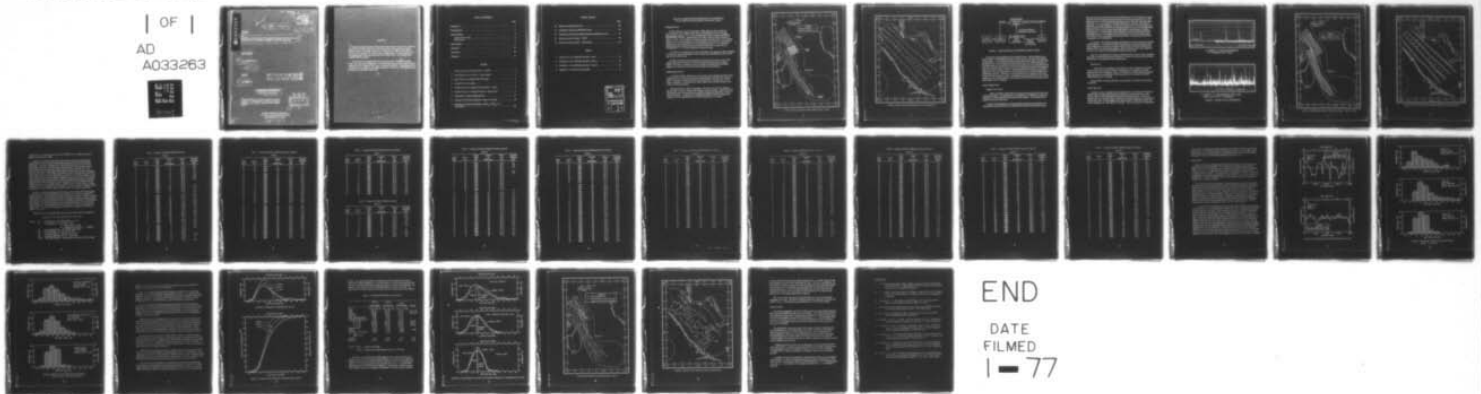

END

DATE
FILMED
1 - 77



MICROCOPY RESOLUTION TEST CHART
NATIONAL BUREAU OF STANDARDS-1963-A

ADA 033263

MOST Project - 2 FG

Good

1

9

INFORMAL
MANUSCRIPT
REPORT

NO. 0-13-64

14 NOO-IM-0-13-64

Jul-Aug 63

TITLE

6 NORMAL INCIDENCE BOTTOM REFLECTION MEASUREMENTS IN THE TONGUE OF THE OCEAN AND EXUMA SOUND, BAHAMAS.

AUTHOR

10 D. A. ATKOCIUS

12 35 p.

DATE

11 JUNE 1964

COPY AVAILABLE TO DDC DOES NOT PERMIT FULLY LEGIBLE PRODUCTION

DISTRIBUTION STATEMENT A

Approved for public release; Distribution Unlimited

This manuscript has a limited distribution, therefore in citing it in a bibliography, the reference should be followed by the phrase UNPUBLISHED MANUSCRIPT.

DDC
RECEIVED
DEC 2 1976
RECEIVED

CP A

MARINE SCIENCES DEPARTMENT
U. S. NAVAL OCEANOGRAPHIC OFFICE
WASHINGTON, D. C. 20390

401 263

Sp-4

-A-

mt

ABSTRACT

↳ Normal incidence bottom reflection loss measurements at 12-kc were conducted from the USS PREVAIL (AGS-20) in the Tongue of the Ocean and Exuma Sound, Bahamas during July through August 1963. Approximately 8000 second bottom reflections were recorded over the 700 miles of tracks steamed in the combined area. The measurements were made underway with an AN/UQN-1 echo sounder and a modified REMPAC system.

The effect of the marginal slopes in the Tongue of the Ocean ^{on} increasing bottom loss values was investigated. Minimizing this effect allowed a more realistic comparison of the Tongue of the Ocean and Exuma Sound data. Results indicate both areas have nearly identical mean bottom losses (19.1 db and 19.2 db) which compare favorably with corrected AMOS data.

A

- B -

TABLE OF CONTENTS

	Page
Introduction	1
Instrumentation	1
Data Collection	4
Tongue of the Ocean	4
Exuma Sound	5
Data Analysis	5
Discussion	20
Conclusions	30
References	51

FIGURES

1 Track Location Chart Areas I and II - TOTO	2
2 Track Location Chart Area III - Exuma Sound	3
3 Block Diagram of Modified REMPAC System	4
4 Sample B and K Recordings	6
5 Station Locations on Tracks of Areas I and II - TOTO	7
6 Station Locations on Tracks of Area III - Exuma Sound	8
7 Fluctuations in Bottom Reflection Loss	21
8 Frequency Distribution Histograms, Area I, II, and III	22
9 Frequency Distribution Histograms, TOTO ₁ , TOTO ₂ , and Exuma Sound	23

FIGURES (Cont'd)

	Page
10 Frequency Distribution Curves	25
11 Cumulative Frequency Distribution Curves	25
12 Comparison of Data and Normal Frequency Distribution Curves	27
13 Bottom Loss Contour Chart - TOTO	28
14 Bottom Loss Contour Chart - Exuma Sound	29

TABLES

1 Summary of bottom reflection loss data - Area I	10
2 Summary of bottom reflection loss data - Area II	12
3 Summary of bottom reflection loss data - Area III	16
4 Comparison of statistical characteristics	26

ACCESSION BY	
NTS	White Section <input checked="" type="checkbox"/>
DDC	Call Section <input type="checkbox"/>
UNANNOUNCED	<input type="checkbox"/>
JUSTIFICATION <i>Folder on file</i>	
BY	
DISTRIBUTION/AVAILABILITY CODES	
Dist. <input type="checkbox"/> AVAIL. <input type="checkbox"/> or SPECIAL	
A	

NORMAL INCIDENCE BOTTOM REFLECTION MEASUREMENTS IN THE TONGUE OF THE OCEAN AND EXUMA SOUND

INTRODUCTION

Bottom reflection measurements using a 12-kc signal at normal incidence were conducted in the Tongue of the Ocean (TOTO) and Exuma Sound in July through August 1963 by U. S. Naval Oceanographic Office personnel aboard the USS PREVAIL (AGS-20). Measurements were made along the tracks indicated in Figures 1 and 2. In the TOTO an attempt was made to collect data over all planned ranges in the Atlantic Undersea Test and Evaluation Center (the Sonar and Acoustic Ranges have been relocated from the areas indicated in Figure 1), in addition to supplementing the existing low frequency data obtained the previous year by NAVOCEANO^{1, 2, 3} in the Weapons and Acoustic Ranges.

The TOTO was divided into two areas to facilitate ship operations and to establish the priority of data requirements in Area I should ship availability not allow surveying the entire TOTO area.

All ship positioning was accomplished by intersection from three or four radar targets when possible and with a radar fix and dead reckoning when necessary. Tracks in the southern portion of Area II could not be completed to the planned length as a complete lack of radar targets precluded any positioning.

INSTRUMENTATION

A modified REMPAC (Reflectivity Measurements in the Pacific) system⁴ as shown in Figure 3 was employed in making the normal incidence reflection loss measurements. Basically, the system consisted of an AN/UQN-1 echo sounder, a linear receiver-amplifier, a Bruel and Kjaer (B&K) single channel graphic recorder, and a low level signal generator.

The system had five modes of operation: (1) receive, (2) receiver calibrate, (3) transmitter calibrate, (4) recorder calibrate, and (5) standby. Modes (2) and (4) were used to insure that the system was properly aligned and calibrated to receive and record signals. Mode (3) was to indicate the stability of the transducer line voltage, but was inoperable due to a lack of components in the system.

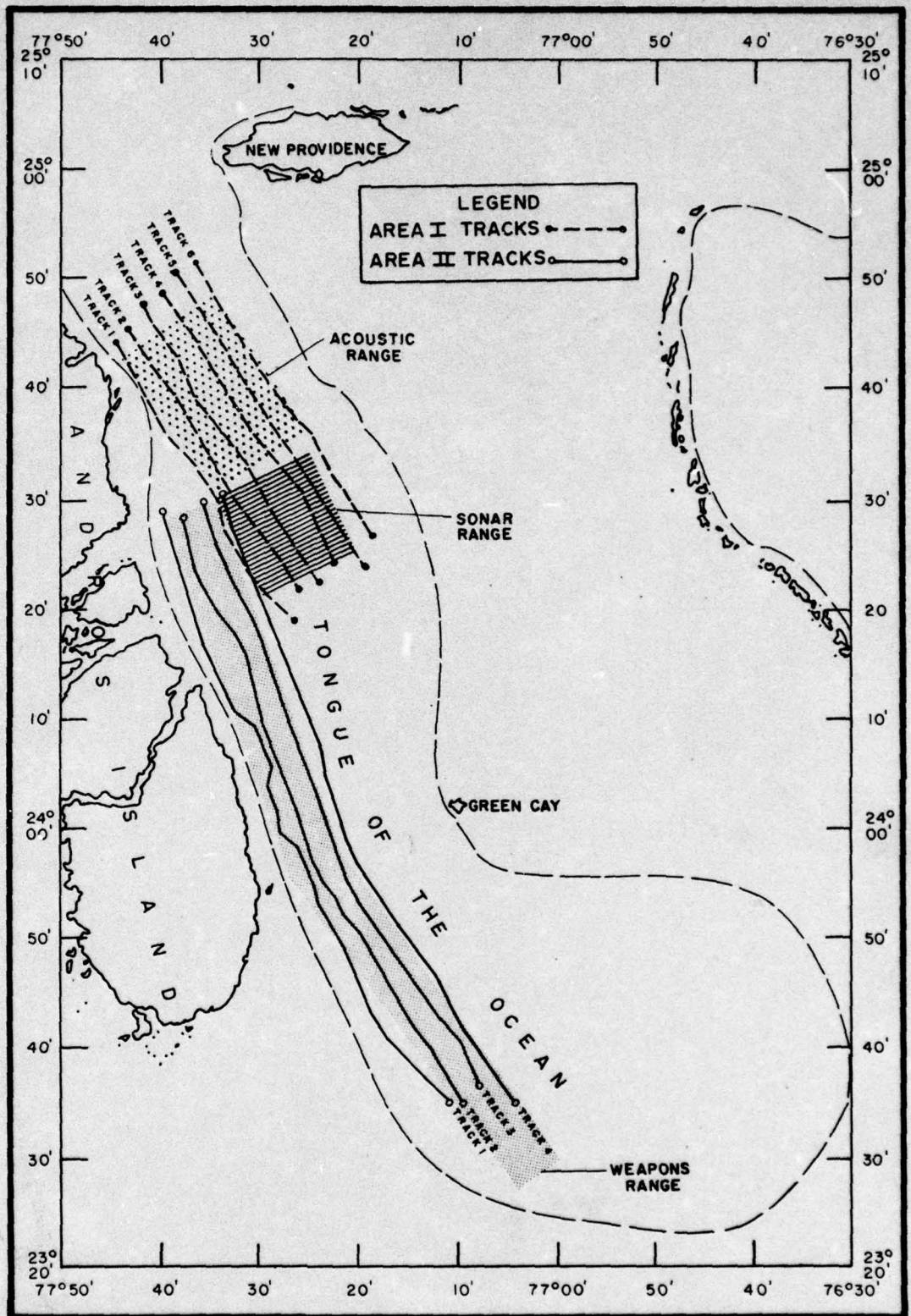

FIGURE 1 TRACK LOCATION CHART AREAS I AND II - TOTO

0-13-64

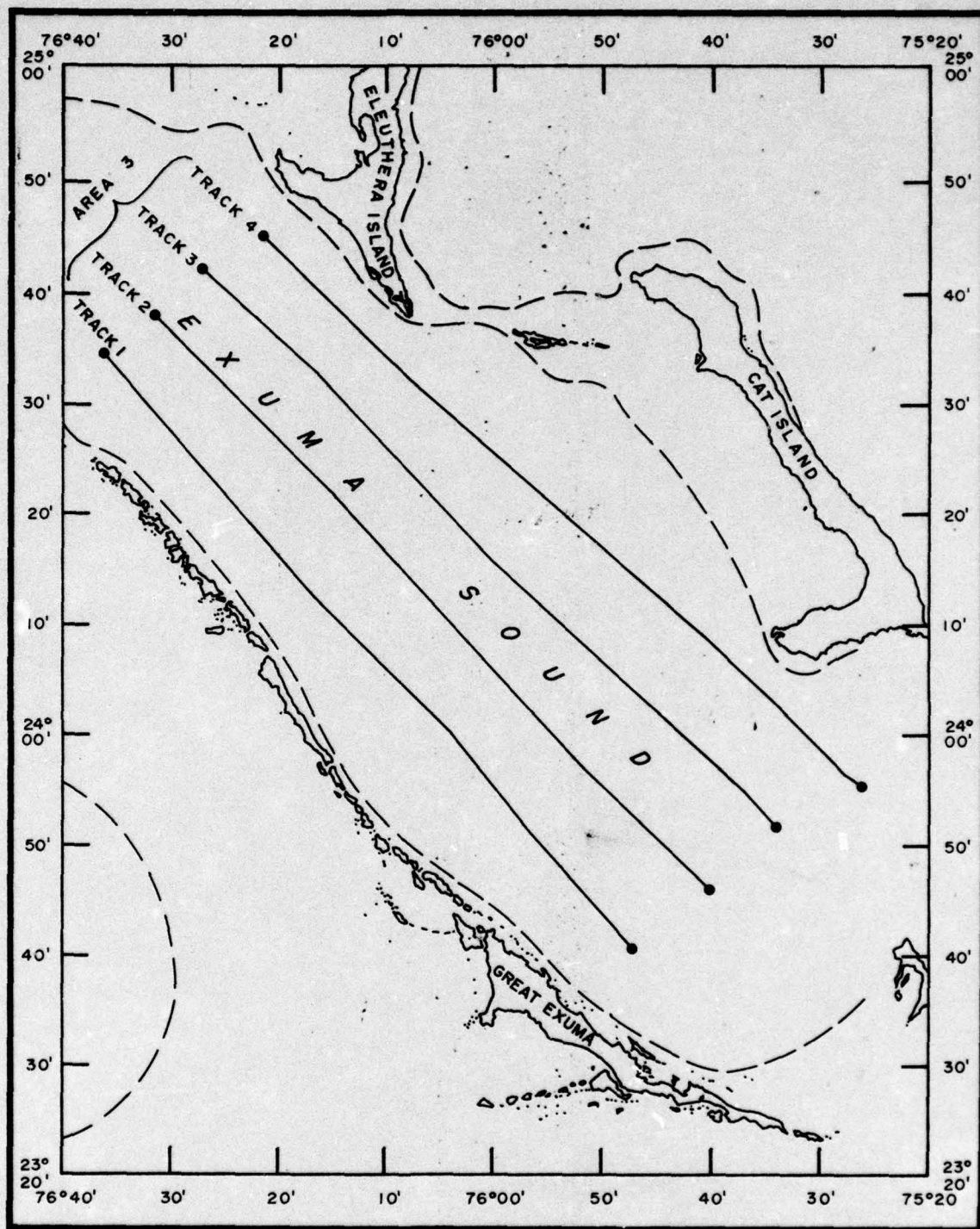

FIGURE 2 TRACK LOCATION CHART AREA III - EXUMA SOUND

0-13-64

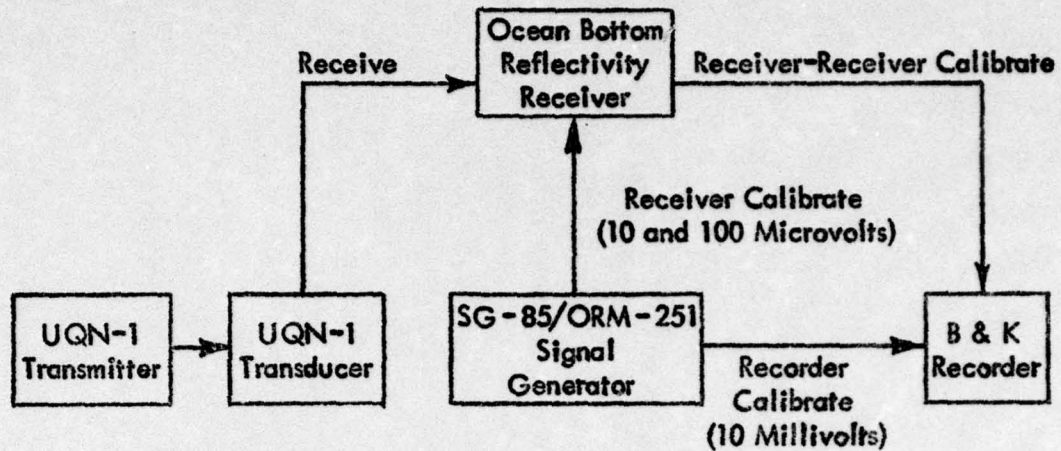

FIGURE 3 BLOCK DIAGRAM OF MODIFIED REMPAC SYSTEM

Two ship-mounted transducers were available for use. Both transducers were checked against a calibrated transducer lowered over the ship's side while drifting in deep waters. The transmitting response of the calibrated transducer was 58.2 db//microbar/volt at 1 meter and the receiving response was -70.9 db//volt/microbar. The peak voltage to the transducer as read on an oscilloscope was approximately 200 volts (141 volts rms) and the source level of the calibrated transducer was calculated to be 101.2 db//microbar at 1 yard. The return signal levels of each of the ship's transducers were nearly identical and only 2 db less than the level measured by the calibrated transducer. Therefore, it was assumed the ship's transducers had output levels of 99.2//microbar at 1 yard. Generally, during operations the ship's forward transducer, mounted flush with the hull, proved less noisy than the dome-type transducer mounted nearer midships.

DATA COLLECTION

Tongue of the Ocean

Bottom reflection measurements were made continuously while the ship was moving at six knots. The echo sounder was operated on the 6000 fathom scale and transmitted a 150 millisecond 12-kc pulse each 30 seconds. At this speed twenty pulses were recorded each mile.

Since the depth transducer was being utilized continuously no fathogram was being printed and depths had to be measured directly from the B&K paper record.

To insure that depths could be read to the desired accuracy of ± 10 fathoms, the paper speed of the B&K recorder was increased from the normal operating speed of 1 millimeter/second to 10 millimeter/second (see Figure 4A) at least each tenth ping (each half mile). For a paper speed of 10 millimeters/second a minimum separation of 5 millimeters was required between outgoing and return pulses to insure the depth error did not exceed 10% (as limited by an average reading accuracy of ± 0.25 millimeters). This factor restricted the accurate operational depth to approximately 1200 feet. Coincidentally, at depths shallower than 1200 feet it became increasingly difficult to distinguish between transmitted and received signals at the normal paper speed. This minimum depth was exceeded several times on run 1 in both Areas I and II with a subsequent loss of usable data.

On occasion, the weather conditions contributed to a loss in quantity and quality of data obtained. Rough seas (Sea State 3 and greater) raised the background noise level considerably and caused a marked increase in ship's roll which decreased the number and/or level of the return signals. Most of the returns that were recorded at this time were obscured in the background noise (see Figure 4B).

Data were collected over six tracks averaging 35 miles each in Area I and along four tracks averaging 60 miles each in Area II. A total of more than 6600 first bottom reflections were recorded over the combined areas.

Exuma Sound

Data collection techniques were the same as those employed in the TOTO except that the ship cruised at a speed of eight knots, thus reducing the density coverage from 20 to 15 pulses per mile. To maintain the desired spacing of accurate depth recordings each half mile, the B&K paper speed was increased to 10 millimeters/second each 7 or 8 pings.

Almost 4000 first bottom reflections were recorded over the four 75 mile tracks in Area III.

DATA ANALYSIS

In order to obtain a common frame of reference for data analysis each track was divided into two-mile segments and each segment was assigned a station number. Figures 5 and 6 indicate the breakdown of each track into stations. There were usually three to six accurate depth recordings on the B&K paper tape for each station. The average value of these readings and a sound velocity of 4960 feet/second were used in computing the water depth for a station. (The sound velocity was determined

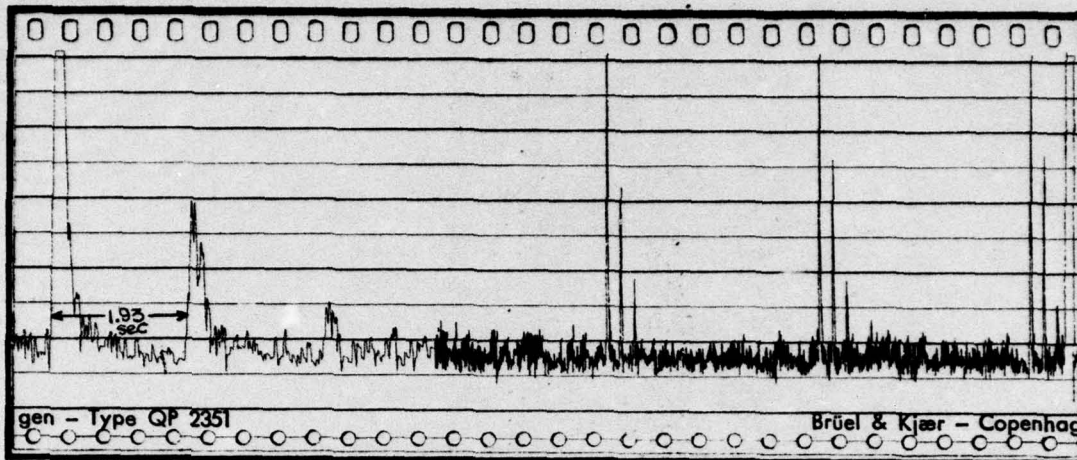

A. EXAMPLE OF DEPTH MEASUREMENT
AT INCREASED PAPER SPEED

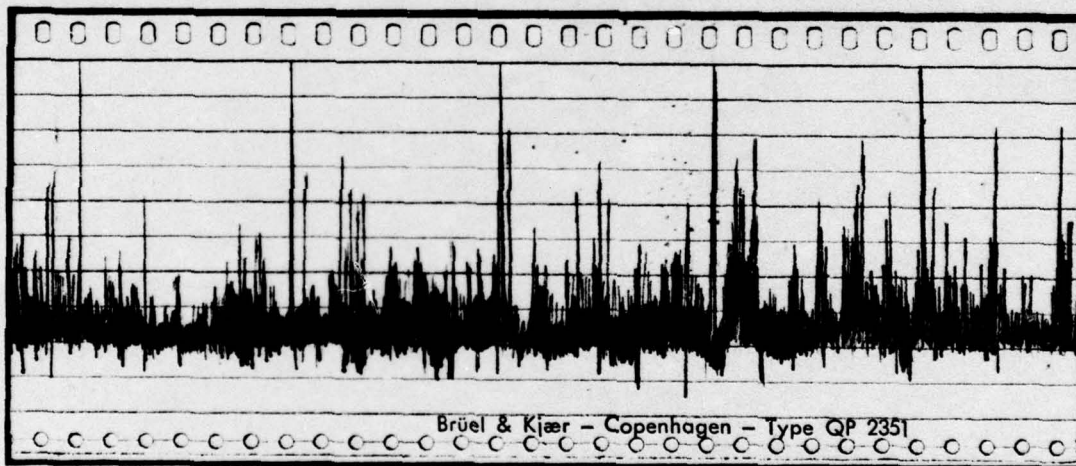

B. EXAMPLE OF HIGH BACKGROUND NOISE LEVEL
DURING SEA STATE 3 CONDITIONS

FIGURE 4 SAMPLE B AND K RECORDINGS

0-13-64

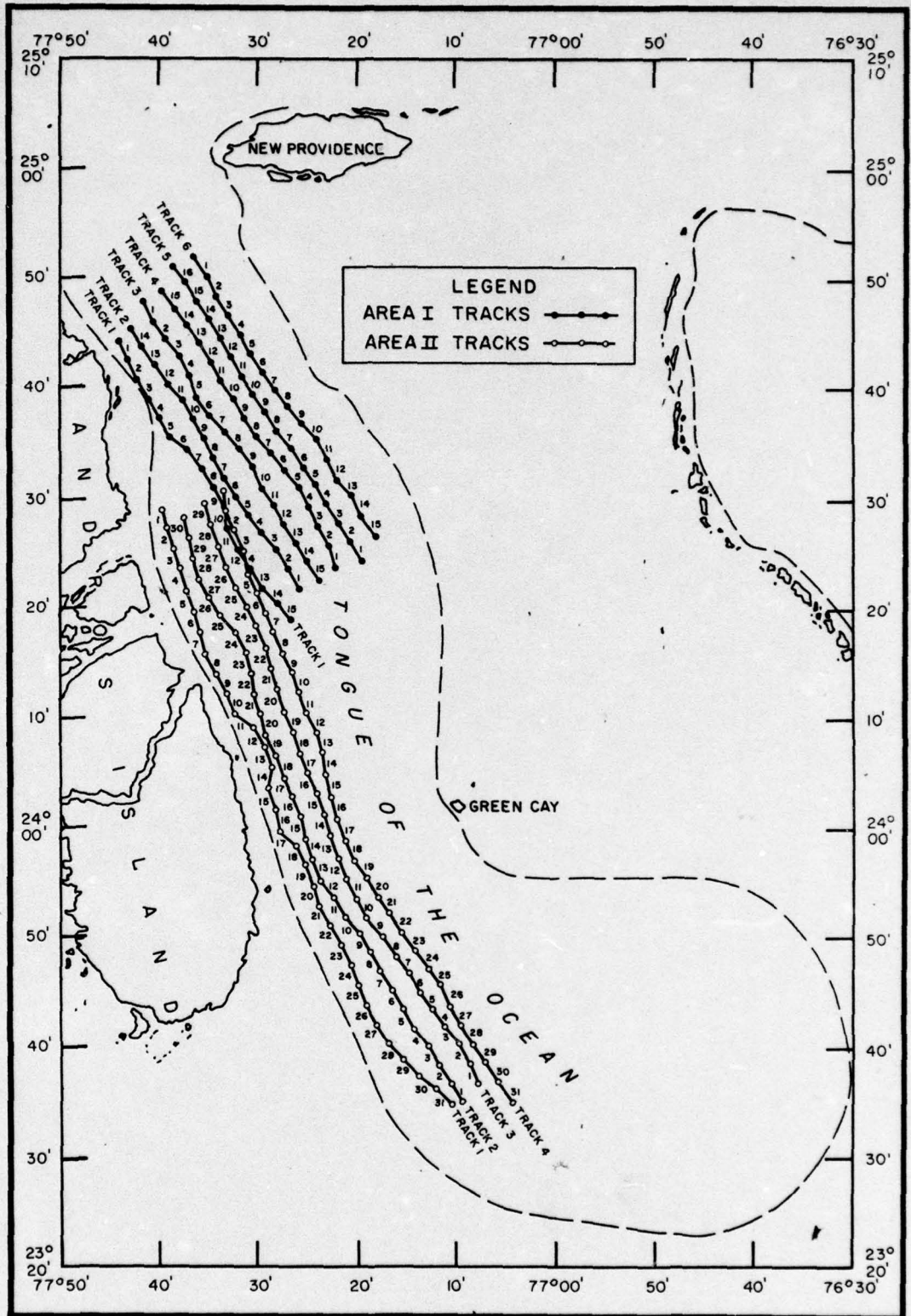

FIGURE 5 STATION LOCATIONS ON TRACKS OF AREAS I AND II - TOTO

D-13-64

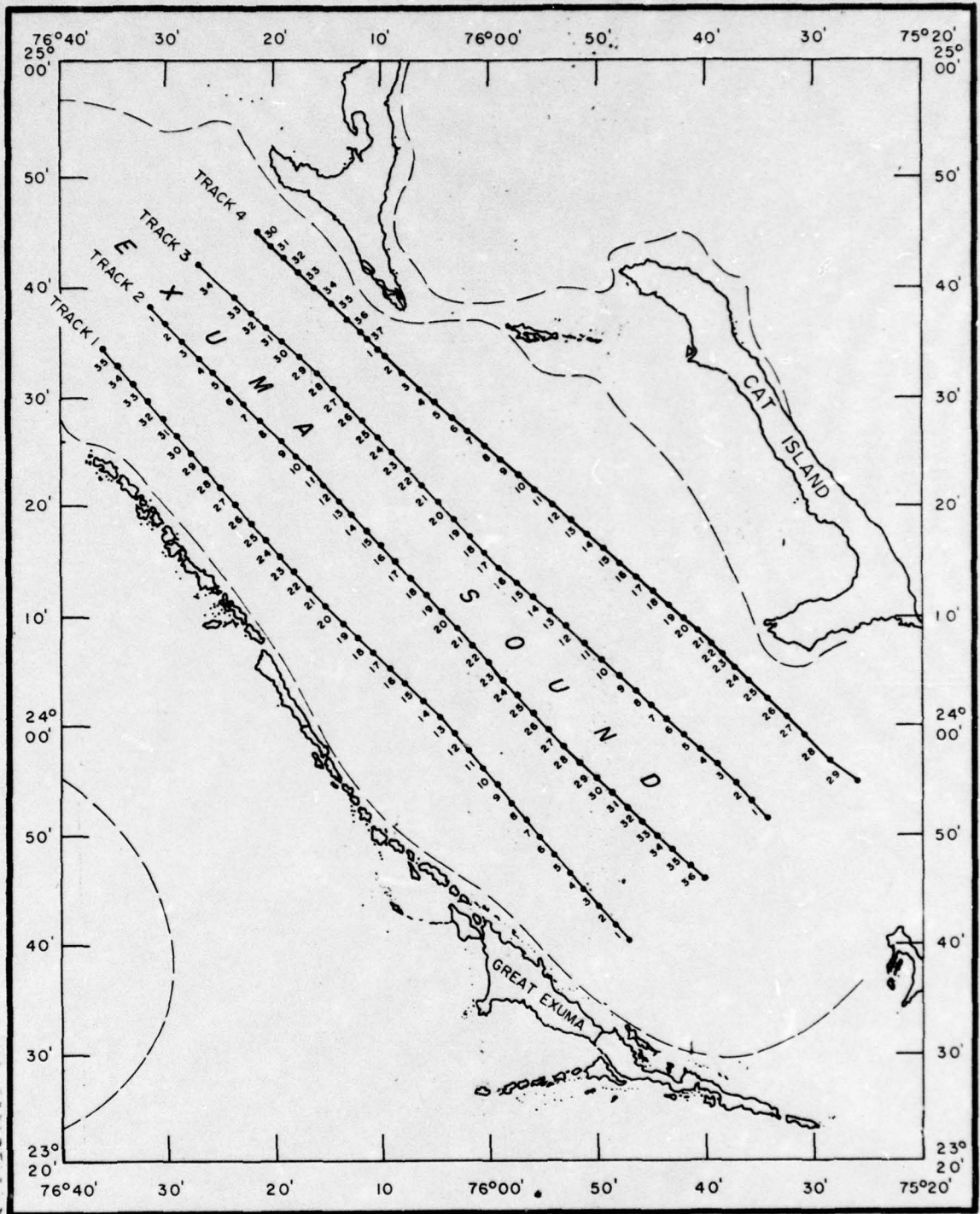

FIGURE 6 STATION LOCATIONS ON TRACKS OF AREA III - EXUMA SOUND

0-13-64

from TOTO oceanographic data and Wilson's Tables⁵ and is a weighted mean for a typical water column in July).

Ideally, each station in the TOTO would contain 40 bottom reflection data values (30 data values in Exuma Sound) from which a mean bottom loss could be determined. Actually, the sample size varied considerably per station as it was affected by fluctuations in ship's speed-over-ground and the loss of signal returns due to shallow depths, rough seas, bottom slopes, bottom roughness, etc. The greatest single factor which reduced the amount of usable data, and thus the sample size of many stations, was that first bottom returns had to be discarded as invalid and only second returns used. The high signal strength of the first bottom returns was outside the linear portion of the amplifier response making the recorded levels erroneous and only second bottom returns could be used in computing bottom losses. The elimination of first returns resulted in a loss of almost 25% of the recorded data (almost 2600 observations had no second returns). Despite all the limiting factors, a reasonable sample size was obtained for most stations. The average number of usable second reflections per station was 21, 29, and 18 for Areas I, II, and III, respectively.

In order to facilitate the analysis of the large amount of data (7912 reflections) a program for computing mean bottom loss per station was written for an IBM 7070 digital computer. Since bottom returns were expressed in decibels, the 7070 computer calculated the antilog of these data values, determined the average absolute value for each station, and then reconverted this value to decibel notation for use in the bottom loss equation. In addition to bottom loss, the standard deviation of bottom returns (which is identical for bottom losses) and the water depth in feet were computed for each station. The results of this program are tabulated separately for each area in Tables 1, 2, and 3.

Mean bottom loss was calculated for each station using the following equation:

$$\text{Bottom Loss} = \text{SL} - \text{PL} + \text{RR} + \text{RG} - \text{AS} - \text{RC} - \text{MPP}$$

where,

- SL = Source Level = 99.1 db/microbar at 1 yard
- PL = Propagation Loss = $20 \log 4D + 4aD$
 - D = Water depth in yards
 - a = Absorption coefficient = 1.1 db/kyd
- RR = Receiving Response = -70.9 db/volt/microbar
- RG = Receiver Gain = 80, 90, 94, or 95 db
- AS = Attenuator Setting = 10, 15, 20, or 25 db
- RC = Recorder Calibration (0 db) = -40 db/volt
- MPP = Mean Peak Pressure = average data value read from B&K record

Table 1 Summary of bottom reflection loss data

Area I

Track No.	Station No.	Water Depth (ft)	Number of Reflections	Bottom Loss (db)	Standard Deviation (db)
1	1	2294	7	24.4	2.8
1	4	1178	11	24.0	5.7
1	5	2696	5	23.9	1.0
1	6	3752	5	21.6	1.6
1	7	4836	15	18.8	3.3
1	8	5372	5	18.0	0.9
1	9	5456	8	18.0	2.3
1	10	5414	2	19.2	
1	11	5372	2	18.2	
1	12	5208	6	19.4	1.2
1	13	5208	10	19.6	1.4
1	14	5146	19	19.3	1.7
1	15	5146	6	19.8	1.6
2	1	5146	5	16.6	2.8
2	2	5208	11	17.9	1.4
2	3	5240	17	17.7	1.1
2	4	5414	24	17.2	2.0
2	5	5456	18	18.4	2.0
2	6	5538	19	18.8	1.2
2	7	5672	19	18.8	1.3
2	8	5610	20	18.6	1.6
2	9	5486	31	17.1	2.8
2	10	4752	20	20.0	1.8
2	11	4504	10	20.4	1.4
2	12	4340	15	21.0	1.7
2	13	3968	15	20.6	3.2
2	14	3833	32	20.0	3.4
3	2	5022	4	17.9	3.3
3	3	5456	6	18.3	4.3
3	5	5406	3	15.5	
3	6	5744	2	14.3	
3	9	5644	6	20.0	1.7
3	10	5744	5	19.7	2.4
3	11	5431	2	18.8	
3	12	5208	6	20.1	2.0

Table 1 Summary of bottom reflection loss data (Cont'd)

Area 1

Track No.	Station No.	Water Depth (ft)	Number of Reflections	Bottom Loss (db)	Standard Deviation (db)
3	13	5208	11	18.4	5.4
3	14	5166	13	20.7	1.4
3	15	5084	22	19.4	4.2
4	1	5208	18	16.7	5.0
4	2	5000	12	19.3	2.1
4	3	5208	34	18.3	2.8
4	4	5300	30	18.7	2.4
4	5	5424	37	17.8	1.8
4	6	5496	26	18.6	1.8
4	7	5672	34	18.3	1.7
4	8	5704	36	17.7	2.4
4	9	5704	25	17.2	1.7
4	10	5858	38	16.4	2.0
4	11	6106	35	17.2	2.1
4	12	6262	21	18.0	1.2
4	13	6423	29	17.9	2.0
4	14	6572	30	17.9	2.0
4	15	6602	27	17.1	1.9
5	1	5084	24	18.3	3.0
5	2	5208	25	18.7	2.5
5	3	5208	37	18.4	1.6
5	4	5208	38	19.5	1.9
5	5	5208	27	19.0	2.5
5	6	5270	46	18.6	2.5
5	7	5486	34	17.1	2.8
5	8	5486	35	18.2	3.3
5	9	5580	29	17.9	2.8
5	10	5610	33	18.1	2.7
5	11	5704	39	18.2	2.0
5	12	5744	33	18.4	1.7
5	13	5858	39	18.9	1.9
5	14	5952	26	18.6	1.5
5	15	6076	18	17.9	2.6
5	16	6014	25	19.1	1.8

Table 1 Summary of bottom reflection loss data (Cont'd)

Area I

Track No.	Station No.	Water Depth (ft)	Number of Reflections	Bottom Loss (db)	Standard Deviation (db)
6	1	4918	16	21.4	2.0
6	2	5000	25	22.2	2.4
6	3	5124	25	21.5	2.0
6	4	5084	30	21.6	2.4
6	5	4910	34	21.4	1.8
6	6	4960	33	20.9	3.6
6	7	5059	37	21.5	1.9
6	8	4836	34	20.8	3.2
6	9	4526	34	22.8	2.6
6	10	4526	40	21.2	2.2
6	11	4836	26	20.1	2.2
6	12	4910	44	19.8	2.8
6	13	4876	35	20.3	2.4
6	14	4886	48	20.9	2.2
6	15	4712	36	20.7	2.3

Table 2 Summary of bottom reflection loss data

Area II

Track No.	Station No.	Water Depth (ft)	Number of Reflections	Bottom Loss (db)	Standard Deviation (db)
1	1	2654	19	23.3	3.9
1	2	3202	28	23.3	2.2
1	3	3286	17	22.7	1.9
1	4	3224	14	20.9	5.0
1	5	3596	12	22.5	2.1
1	6	3720	16	21.5	2.0
1	7	2852	3	22.3	
1	8	2232	5	24.3	2.1
1	9	1570	11	24.1	2.8
1	10	1466	10	26.2	3.7
1	11	1860	12	23.7	4.4

Table 2 Summary of bottom reflection loss data (Cont'd)

Area II

Track No.	Station No.	Water Depth (ft)	Number of Reflections	Bottom Loss (db)	Standard Deviation (db)
1	12	3016	12	22.6	2.5
1	13	3224	6	20.4	1.8
1	14	3100	16	21.4	2.5
1	15	1736	2	25.1	
1	16	1984	6	25.2	3.4
1	17	2542	6	22.5	5.3
1	18	3720	2	20.5	
1	19	3596	3	21.9	
1	23	3720	2	19.5	
1	24	3720	2	20.5	
1	27	4154	2	23.0	
1	28	4526	2	17.2	
1	30	4464	3	19.4	
1	31	4402	8	21.5	1.4
2	1	4464	31	19.2	1.7
2	2	4464	35	19.8	3.1
2	3	4504	33	21.0	1.9
2	4	4494	35	20.3	4.2
2	5	4340	32	21.4	2.3
2	6	4489	35	21.3	1.8
2	7	4464	30	20.5	1.9
2	8	4494	38	20.2	1.6
2	9	4422	32	19.8	1.6
2	10	4402	36	19.2	2.5
2	11	4422	33	19.6	2.2
2	12	4464	43	18.4	1.7
2	13	4154	31	20.5	2.4
2	14	4154	32	21.5	2.4
2	15	4008	38	20.7	2.2
2	16	4067	42	20.0	2.4
2	17	3782	42	22.5	1.9
2	18	3626	38	21.0	2.5
2	19	3596	35	21.4	3.7
2	20	3720	36	21.3	3.1
2	21	4092	45	19.9	3.6

Table 2 Summary of bottom reflection loss data (Cont'd)

Area II

Track No.	Station No.	Water Depth (ft)	Number of Reflections	Bottom Loss (db)	Standard Deviation (db)
2	22	4414	42	19.4	3.8
2	23	4836	43	18.2	2.8
2	24	4836	39	17.5	2.0
2	25	4811	42	18.3	2.9
2	26	4628	39	19.4	4.1
2	27	4395	36	20.4	2.3
2	28	4092	32	21.2	2.5
2	29	4216	35	21.0	2.7
2	30	4154	37	21.5	2.5
3	1	4464	23	18.1	2.0
3	2	4464	33	19.5	2.3
3	4	4464	41	20.5	1.7
3	5	4464	29	19.9	2.2
3	6	4464	35	20.4	1.6
3	7	4504	35	20.3	1.9
3	8	4630	44	21.1	2.2
3	9	4556	36	20.7	1.9
3	10	4504	39	20.4	2.3
3	11	4556	34	19.5	2.4
3	12	4588	31	19.0	2.2
3	13	4494	34	19.4	2.0
3	14	4628	36	19.0	2.3
3	15	4588	29	19.1	2.3
3	16	4628	32	19.0	1.9
3	17	4712	34	19.2	2.0
3	18	4680	30	18.3	1.7
3	19	4742	34	18.5	2.6
3	20	4712	33	19.2	2.4
3	21	4898	35	19.5	2.4
3	22	4866	36	18.6	2.8
3	23	4960	42	18.8	1.3
3	24	4985	46	19.5	2.0
3	25	4960	44	19.8	2.3
3	26	5022	39	19.7	2.4
3	27	5208	33	18.5	2.1
3	28	5124	24	19.8	3.4
3	29	5208	26	18.7	3.6

Table 2 Summary of bottom reflection loss data (Cont'd)

Area II

Track No.	Station No.	Water Depth (ft)	Number of Reflections	Bottom Loss (db)	Standard Deviation (db)
4	1	5372	38	19.1	2.1
4	2	5322	36	18.8	2.8
4	3	5208	34	19.1	1.9
4	4	5208	35	19.0	1.9
4	5	5166	35	18.9	2.3
4	6	5084	40	19.2	2.3
4	7	4960	42	18.6	2.4
4	8	4960	35	19.9	1.8
4	9	4960	43	19.6	2.0
4	10	4928	35	18.9	1.6
4	11	4712	37	18.7	1.5
4	12	4712	38	18.5	1.9
4	13	4742	40	18.4	2.1
4	14	4712	34	18.0	1.8
4	15	4712	42	17.5	2.1
4	16	4680	40	18.1	2.5
4	17	4670	29	18.4	1.8
4	18	4588	40	18.8	3.3
4	19	4504	31	19.2	3.8
4	20	4526	39	19.9	1.7
4	21	4494	33	19.3	1.7
4	22	4504	37	19.2	1.9
4	23	4495	37	19.4	1.8
4	24	4494	39	19.3	2.6
4	25	4504	35	19.3	1.7
4	26	4504	37	19.2	2.5
4	27	4464	38	18.8	2.1
4	28	4464	40	19.3	1.9
4	29	4429	40	17.5	2.6
4	30	4464	40	17.8	2.1
4	31	4464	23	19.4	1.5

Table 3 Summary of bottom reflection loss data

Area III

Track No.	Station No.	Water Depth (ft)	Number of Reflections	Bottom Loss (db)	Standard Deviation (db)
1	1	4794	8	20.2	1.6
1	2	5024	7	19.7	1.5
1	3	5208	9	19.5	1.4
1	4	5451	9	17.7	2.3
1	5	5535	11	18.1	1.3
1	6	5625	17	17.7	1.9
1	7	5602	11	18.8	1.9
1	8	5652	13	18.6	2.0
1	9	5672	15	18.2	1.7
1	10	5749	12	17.7	1.6
1	11	5736	11	18.4	2.7
1	12	5704	11	18.8	2.2
1	13	5697	10	18.7	2.1
1	14	5654	13	19.4	1.0
1	15	5716	16	18.2	1.3
1	16	5625	13	19.0	1.3
1	17	5580	23	18.6	2.6
1	18	5580	16	19.0	1.7
1	19	5649	17	18.3	2.1
1	20	5625	14	19.1	1.5
1	21	5550	8	18.4	1.2
1	22	5404	13	19.4	2.8
1	23	5369	8	19.8	1.6
1	24	5282	6	19.1	2.2
1	25	5357	10	19.4	1.1
1	26	5089	3	19.3	
1	27	4799	3	19.2	
1	28	4538	5	19.0	2.6
1	29	4432	12	20.2	2.2
1	30	4705	12	20.3	1.9
1	31	4910	5	19.8	1.5
1	32	4928	13	20.7	1.3
1	33	4657	12	18.7	5.5
1	34	4595	29	20.4	1.8
1	35	4690	26	20.3	2.0

Table 3 Summary of bottom reflection loss data (Cont'd)

Area III

Track No.	Station No.	Water Depth (ft)	Number of Reflections	Bottom Loss (db)	Standard Deviation (db)
2	1	5344	24	19.8	1.6
2	2	5372	28	19.8	1.7
2	3	5399	32	19.3	1.7
2	4	5387	21	19.5	1.7
2	5	5449	25	19.8	1.7
2	6	5496	26	20.0	1.3
2	7	5555	16	20.3	1.3
2	8	5587	17	20.2	1.0
2	9	5540	26	20.2	1.0
2	10	5630	15	20.0	1.5
2	11	5617	16	20.2	0.8
2	12	5617	7	20.2	1.0
2	13	5821	12	20.2	1.1
2	14	5828	12	20.2	1.0
2	15	5803	16	19.4	1.5
2	16	5821	28	19.0	1.7
2	17	5813	25	19.6	1.7
2	18	5835	30	18.7	1.8
2	19	5878	24	18.8	1.4
2	20	5910	27	18.8	1.9
2	21	5902	20	19.3	1.4
2	22	5969	24	18.9	1.6
2	23	5994	17	19.0	1.6
2	24	5952	14	19.1	1.1
2	25	5927	17	19.2	1.6
2	26	5952	19	19.7	1.3
2	27	6002	18	19.0	1.3
2	28	6014	20	19.2	1.4
2	29	6056	19	19.4	1.0
2	30	6150	16	19.2	1.1
2	31	6101	11	19.1	1.7
2	32	6175	15	17.5	2.6
2	33	6141	24	16.9	2.7
2	34	6113	24	17.9	1.8
2	35	6051	25	18.5	2.0
2	36	5972	22	18.5	1.6

Table 3 Summary of bottom reflection loss data (Cont'd)

Area III

Track No.	Station No.	Water Depth (ft)	Number of Reflections	Bottom Loss (db)	Standard Deviation (db)
3	1	6547	19	17.2	2.5
3	2	6656	2	16.8	
3	3	6674	12	17.8	1.9
3	4	6537	12	17.8	1.5
3	5	6416	18	17.6	1.5
3	6	6376	18	17.6	2.2
3	7	6346	19	18.5	1.1
3	8	6269	14	18.1	2.1
3	9	6205	18	18.4	1.2
3	10	6128	16	19.0	1.3
3	11	6148	20	17.9	2.0
3	12	6106	26	17.8	1.8
3	13	6056	19	17.9	2.6
3	14	6002	23	18.7	1.9
3	15	5937	25	18.8	1.2
3	16	5875	20	19.1	1.7
3	17	5915	24	18.8	1.5
3	18	5878	29	18.5	2.5
3	19	5902	33	18.2	2.2
3	20	5868	21	18.5	2.1
3	21	5840	19	18.5	2.2
3	22	5806	8	19.8	1.7
3	23	5754	8	18.9	1.6
3	24	5716	24	19.3	1.7
3	25	5684	6	20.2	0.7
3	26	5640	12	20.1	0.9
3	27	5550	14	20.0	1.0
3	28	5568	21	19.9	1.3
3	29	5538	14	20.1	1.3
3	30	5476	12	19.9	1.4
3	31	5431	24	20.4	1.4
3	32	5387	24	20.3	1.3
3	33	5364	26	20.0	1.4
3	34	5307	25	20.1	1.4

Table 3 Summary of bottom reflection loss data (Cont'd)

Area III

Track No.	Station No.	Water Depth (ft)	Number of Reflections	Bottom Loss (db)	Standard Deviation (db)
4	1	5156	53	19.6	2.1
4	2	5394	37	18.6	2.0
4	3	5367	34	18.2	3.3
4	4	5300	36	18.9	2.5
4	5	5332	46	18.2	2.6
4	6	5456	31	19.2	1.4
4	7	5476	28	18.4	2.8
4	8	5456	15	19.6	1.0
4	9	5610	19	19.1	1.8
4	10	5630	6	19.4	1.4
4	11	5610	6	19.1	1.6
4	12	5610	9	19.3	1.8
4	13	5662	10	19.0	0.9
4	14	5580	14	19.2	1.5
4	15	5704	12	19.2	1.4
4	16	5711	20	18.7	1.7
4	17	5597	20	18.3	2.0
4	18	5518	27	18.8	2.2
4	19	5456	24	18.7	1.9
4	20	5243	36	19.1	2.5
4	21	5342	37	18.8	2.0
4	22	5049	36	19.7	2.3
4	23	5307	8	18.1	2.7
4	24	5096	4	20.3	1.3
4	25	5506	17	18.5	2.4
4	26	6036	11	18.5	1.4
4	27	6131	17	17.7	2.7
4	28	6478	3	18.7	
4	29	6912	6	18.2	1.0
4	30	4825	36	20.6	1.9
4	31	4545	29	21.2	2.4
4	32	4563	11	20.6	2.4
4	33	4645	22	20.1	3.4
4	34	4561	25	21.9	2.1
4	35	4598	28	19.8	3.0
4	36	4980	30	20.1	2.3
4	37	5163	30	19.8	1.7

The absorption coefficient was determined using the Schulkin and Marsh equation for absorption⁶. The coefficient used for the entire water column was a weighted mean of the coefficients computed for each of the fourteen separate layers used to define the typical temperature and salinity profile for this area in July.

DISCUSSION

Figure 7 gives some indication of the extreme of fluctuations in bottom loss encountered over two-mile stations. The cause of these fluctuations has not been defined and will not be dealt with here. However, it should be noted that variations of the same order have been observed and possible explanations discussed in the analyses of REMPAC data^{7, 8}. Although there was substantial variation in the levels of individual observations of Station 22 (a range of 14 db) the mean bottom loss nearly equaled that of Station 23 (within 0.6 db) - and the latter station had a standard deviation only one-third as large.

That the mean bottom losses showed no great divergences from station to station, and indeed from area to area, proved to be the rule and not the isolated coincidence. Considering the 340 stations from all three areas, the tables indicate the range of bottom losses to be from a low of 14.3 db (Station 6, Run 3, Area I) to a high of 26.2 db (Station 10, Run 1, Area II). If four data values were selected as a minimum sample size, then 18 stations of doubtful value would be eliminated and the range of data then would be 16.4 db to 26.2 db. The frequency distribution histograms of Figure 8 are based on data from stations with four or more observations. Although there is some variation in the general shape of each histogram, the mean losses for the three areas compare favorably (19.1 db, 19.4 db, and 20.0 db).

A more meaningful comparison of areas resulted when the stations of Areas I and II were combined into one representative area for the TOTO and compared to the data of Exuma Sound as in Figure 9. The two different frequency distribution histograms for the combined stations of the TOTO are presented in this figure to indicate the relative effect of slope on bottom losses. The top histogram (TOTO₁) presents all data, whereas the second histogram (TOTO₂) includes only the values for stations in depths greater than 4000 feet. (This depth was arbitrarily chosen in an attempt to eliminate most of the area with slopes greater than 3 degrees - in number, only 25 stations of the 184 total were eliminated). It is clear that the top histogram exhibits a much greater spreading tendency to high loss levels than does the TOTO₂ histogram. This tendency results directly from the fact that the 25 stations in depths less than 4000 feet had a relatively high range of bottom loss values (from 20.0 db to 26.2 db) and a mean loss (22.6 db) almost 3 db greater than that of any other area. For comparison with Exuma Sound, the TOTO₂ histogram provides the more realistic frequency

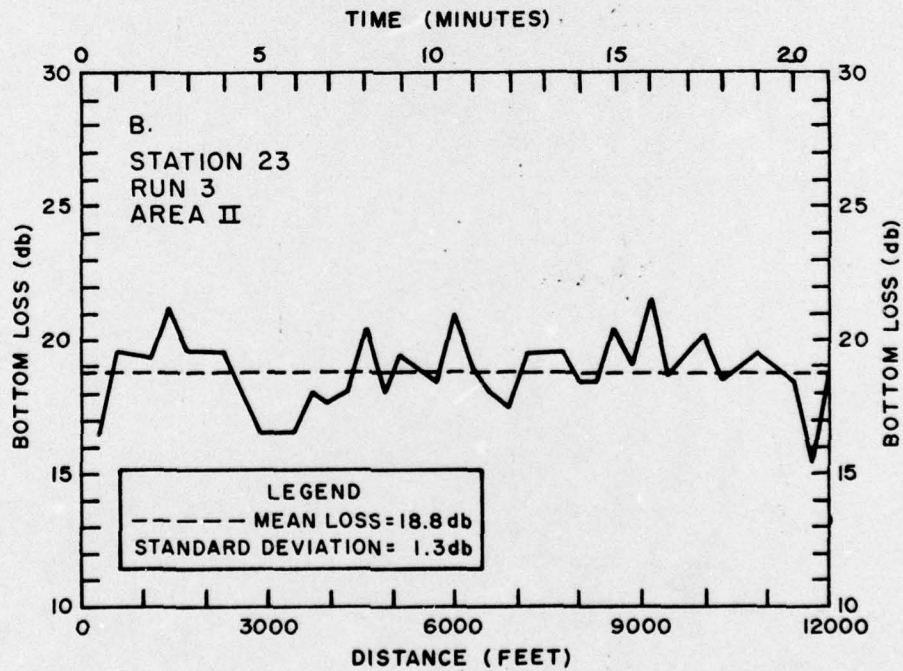
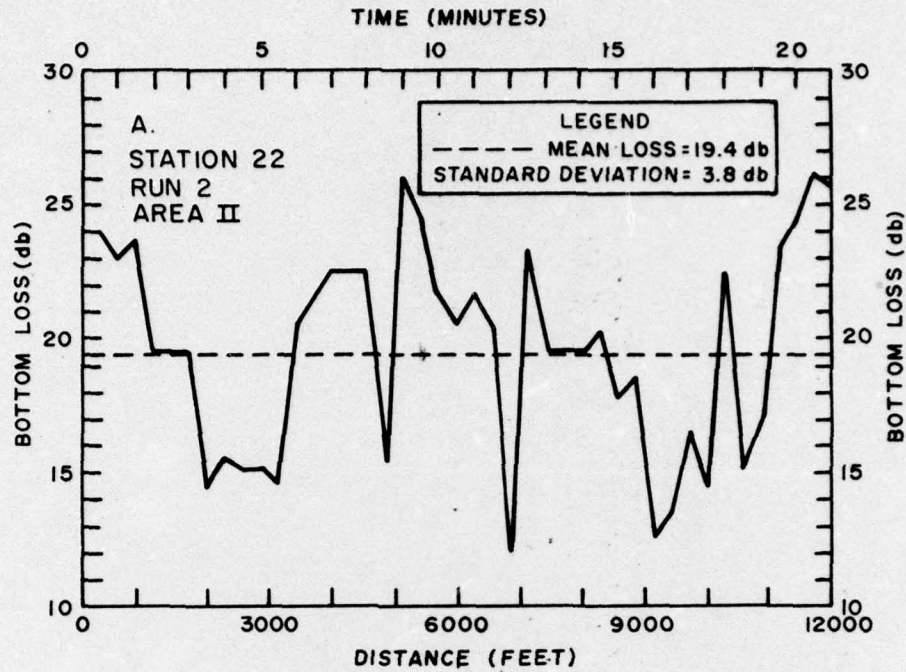

FIGURE 7 FLUCTUATIONS IN BOTTOM REFLECTION LOSS

0-13-64

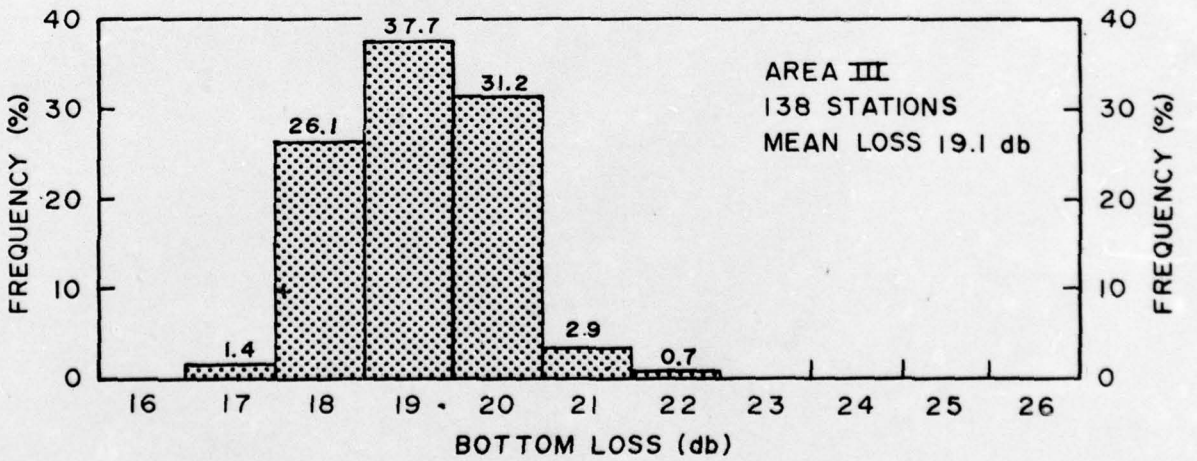
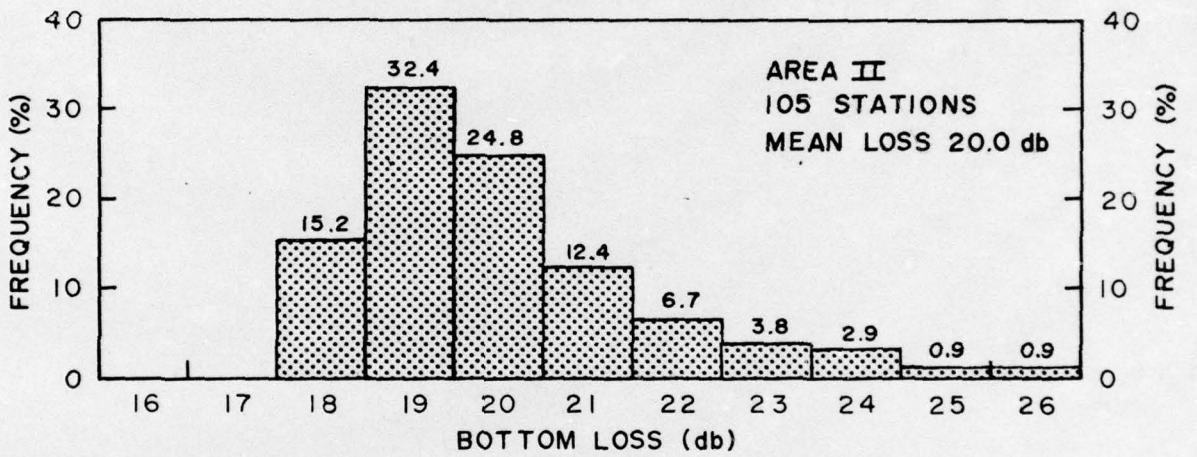
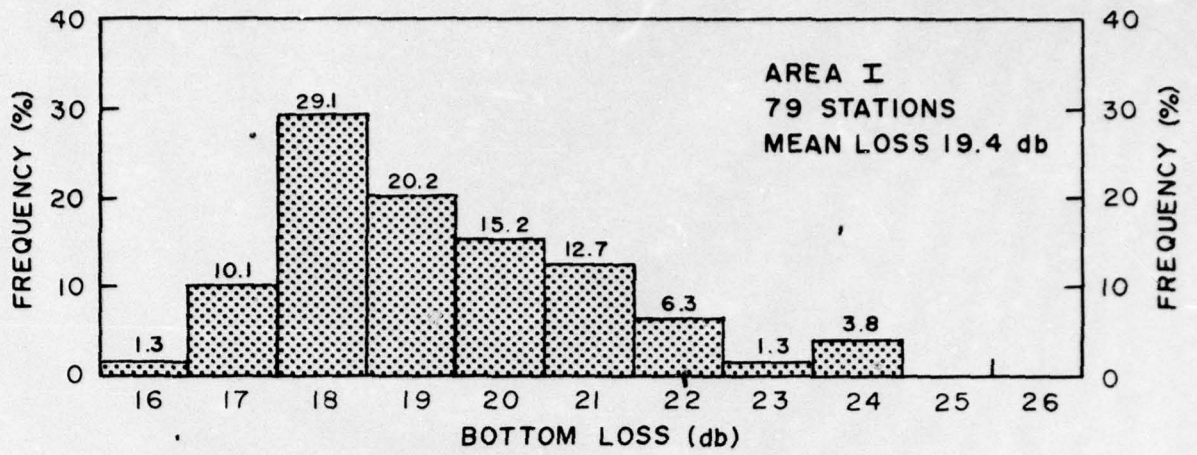

FIGURE 8 FREQUENCY DISTRIBUTION HISTOGRAMS
AREAS I, II, AND III

0-13-64

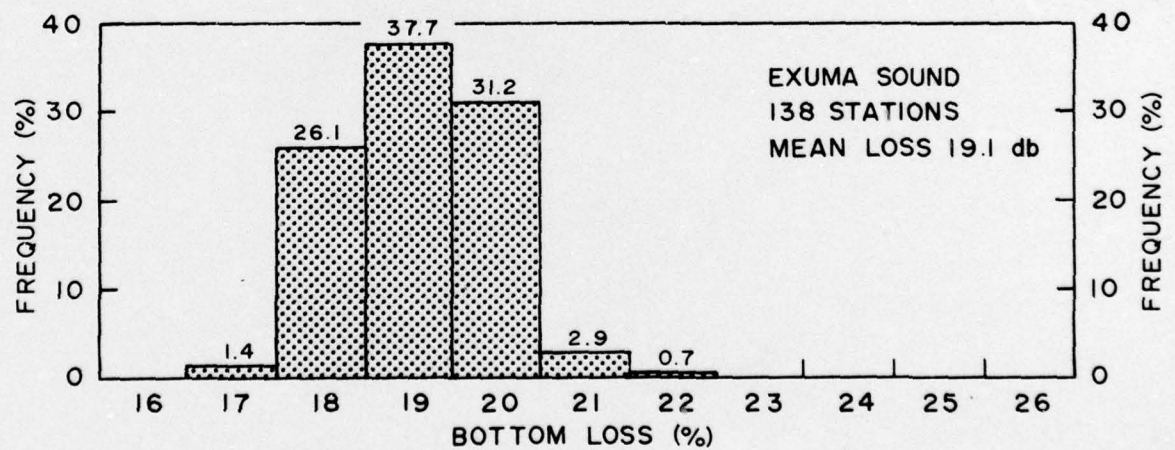
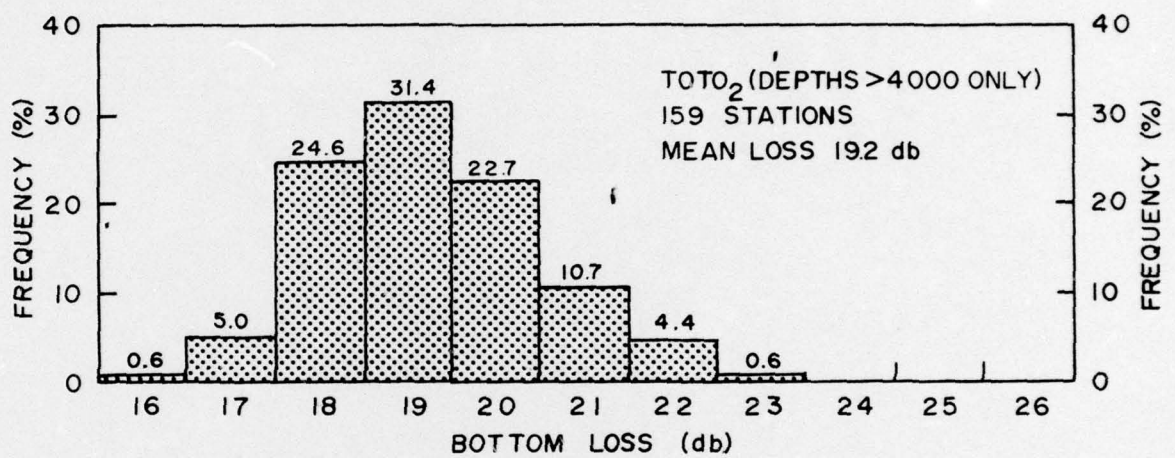
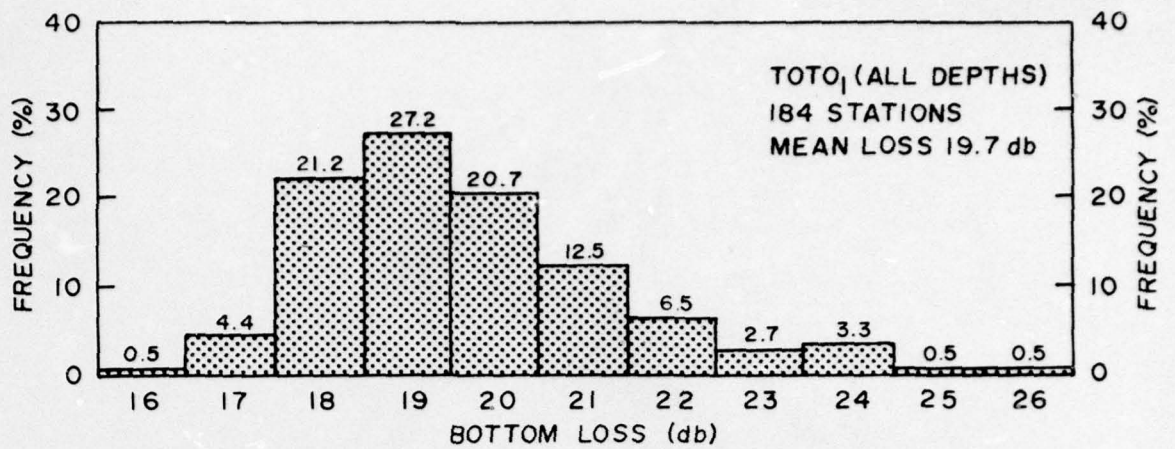

FIGURE 9 FREQUENCY DISTRIBUTION HISTOGRAMS
TOTO₁, TOTO₂, AND EXUMA SOUND

0-13-64

distribution as the entire area traversed in Exuma Sound was over a similarly flat bottom in depths always greater than 4000 feet.

Figure 10 presents the three smoothed frequency distribution curves resulting from drawing line segments joining the mid-points at the top of each column of the respective histograms. These curves clearly indicate: (1) the higher loss values over slopes increased the right skewness of the TOTO₁ distribution, and (2) the closer similarity of TOTO₂, rather than TOTO₁, data with the Exuma Sound data.

The cumulative frequency distribution curves of Figure 11 further emphasize (2) above by indicating that fully 95 to 98% of the data of TOTO₂ and Exuma Sound fall within a range of 16 to 21 db whereas only 85% of the TOTO₁ data are in this range. (NOTE: The percentages used here are to indicate only the similarity in distributions and are not statistical levels of confidence that predict the probability of occurrences about a mean).

Additional and more detailed statistical analyses of the three sets of data were performed and are presented in Table 4 where they can be compared to each other and to normal distribution values. It can be seen from this table and from Figure 12, the comparison of the smoothed distribution curves versus computed normal curves, that all three sets of data do not vary greatly from a normal distribution. Exuma Sound shows the most normal distribution and TOTO₁ shows the greatest deviation from normal in all but one of the fourteen statistical characteristics listed in Table 4.

In a further attempt to define the effect of bottom slope on reflection losses in the TOTO and Exuma Sound contour charts of bottom loss were prepared and are presented in Figures 13 and 14. Those stations with less than 4 reflections were excluded. (The bottom loss values as originally computed to the nearest 0.1 db were plotted rather than rounding loss values to the nearest whole integer as done in the sorting into class intervals in the statistical analyses).

Although the line spacing varied from 5 miles in the TOTO to 12 miles in Exuma Sound, it was sufficiently close to determine general patterns. Specifically, a contour pattern in the TOTO which indicates a definite parallel trend of increasing bottom losses with increasing shoreward slopes and, conversely, the lack of any definite contour pattern in Exuma Sound where strong slopes exist but were not traversed.

An effort was made to correlate cross-sections of bottom loss and bottom slope even though no reflection lines were run normal to the trend of the slope. The most recent charts (NAVOCEANO Charts 5953 and 5956 of February 1963 and Athearn's charts⁹ of December 1960) were used in drawing several bottom cross sections of the

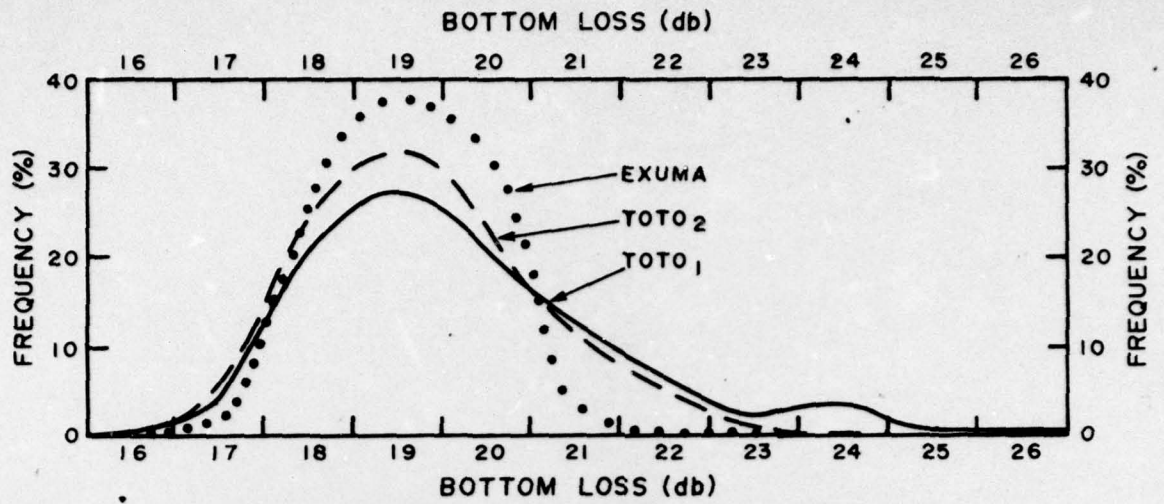

FIGURE 10 FREQUENCY DISTRIBUTION CURVES

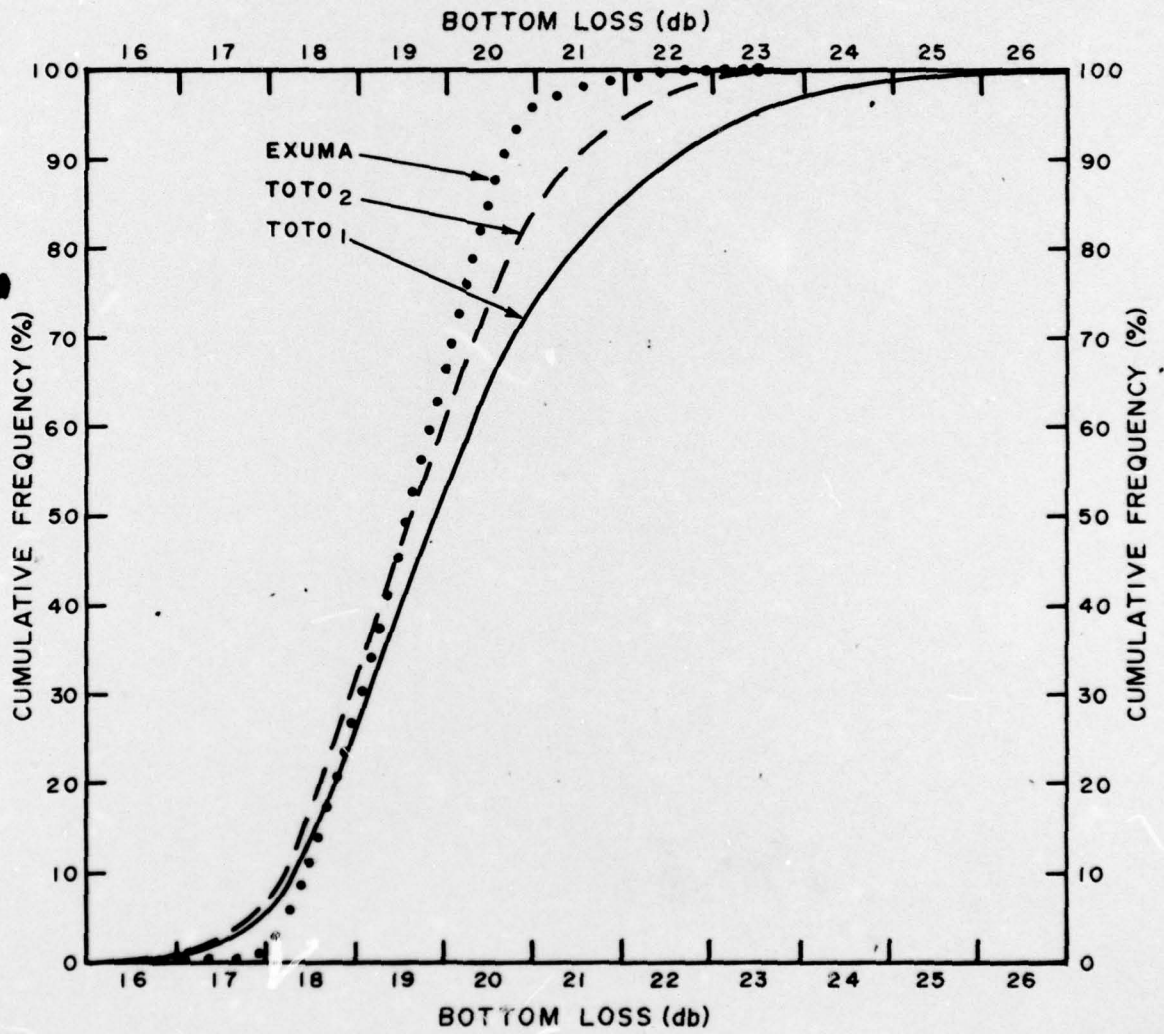

FIGURE 11 CUMULATIVE FREQUENCY DISTRIBUTION CURVES

0-13-64

TOTO. The marked irregularity of the bathymetry of the marginal slopes made specific correlations impossible. (As Athearn observed, gullies nearly normal to the trend of the marginal slopes occur at approximately 1 mile intervals and present considerable relief variations of up to 100 fathoms between gullies and ridges). An approximate increase in loss of 2 to 4 db per mile over marginal slopes was measured.

Table 4 Comparison of statistical characteristics

	TOTO ₁ (184 Stations)	TOTO ₂ (159 Stations)	Exuma (138 Stations)	Normal
Range	16.4 - 26.2 db	16.4 - 22.8 db	16.9 - 21.2 db	
Mode	18.99	18.98	19.04	Same as \bar{X}
Median	19.38	19.13	19.10	Same as \bar{X}
Mean (\bar{X})	19.68	19.23	19.10	
Mean Deviation (MD)	1.35	1.02	0.71	
Standard Deviation (SD)	1.71	1.27	0.90	
$\bar{X} \pm 1$ SD	71.0%	69.0%	67.0%	68.0%
$\bar{X} \pm 2$ SD	95.0%	96.0%	97.0%	95.0%
$\bar{X} \pm 3$ SD	99.2%	99.7%	99.6%	99.7%
Variance (SD) ²	2.94	1.61	0.81	
MD/SD	0.787	0.791	0.789	0.798
Coefficient of Variation $(\frac{SD}{\bar{X}} \times 100)$	8.7%	6.6%	4.7%	
Kurtosis	4.16	2.94	2.77	3.00
Skewness	+0.60	+0.24	+0.11	0.00

NOTE: TOTO₁ - Includes all stations

TOTO₂ - Includes only those stations with depths >4000 feet

However, a more definite correlation between bottom loss and bottom slope emerged when the area of slopes less than 3 degrees was plotted on the bottom loss contour chart (the shaded area of Figure 13). Inside this almost flat area iso-loss contour values seldom exceed 20 db and, in fact, the 3 degree area limit hardly varies outside the 18 to 20 db contour interval. Contrastingly, outside this area, where slopes average 12 to 15 degrees and increase to 30 degrees before reaching

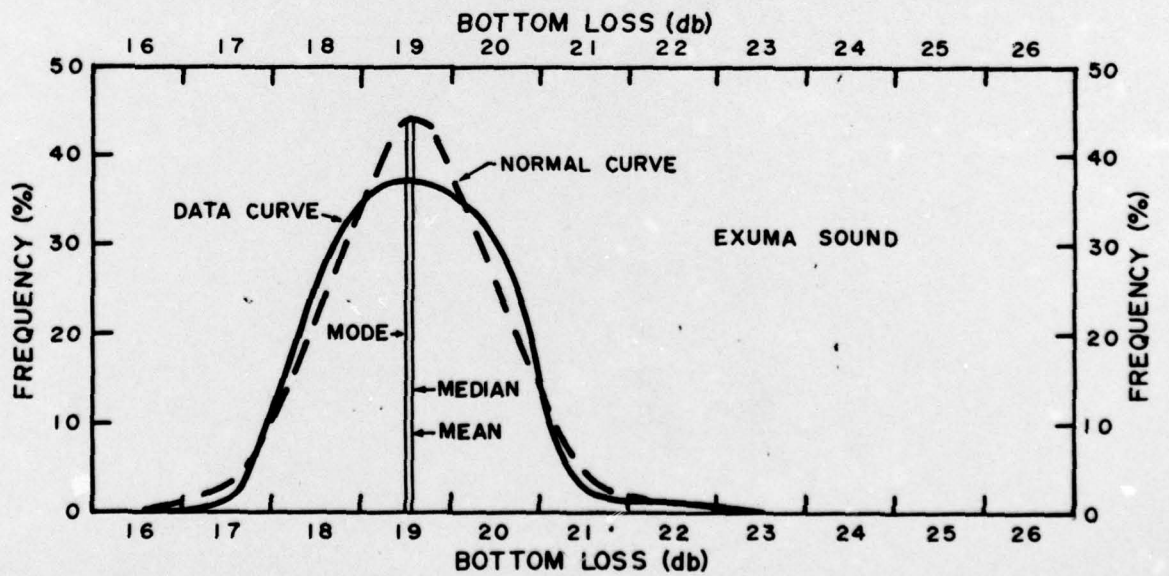
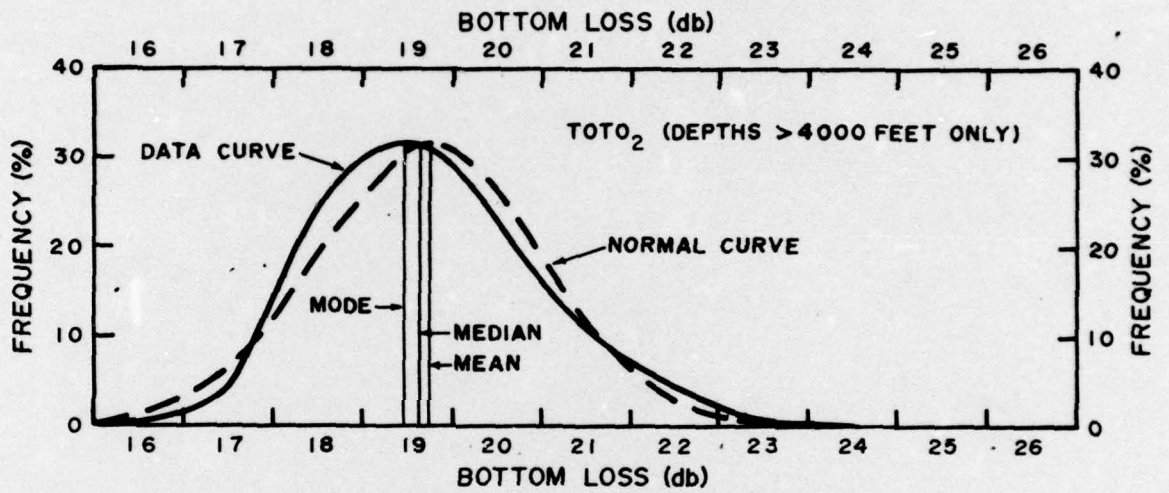
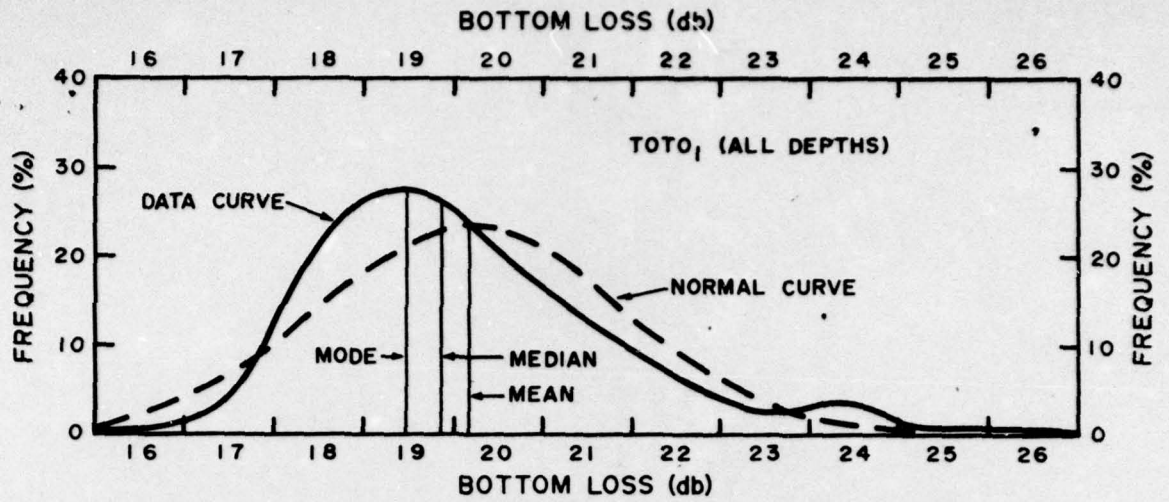

FIGURE 12 COMPARISON OF DATA AND NORMAL FREQUENCY DISTRIBUTION CURVES

0-13-64

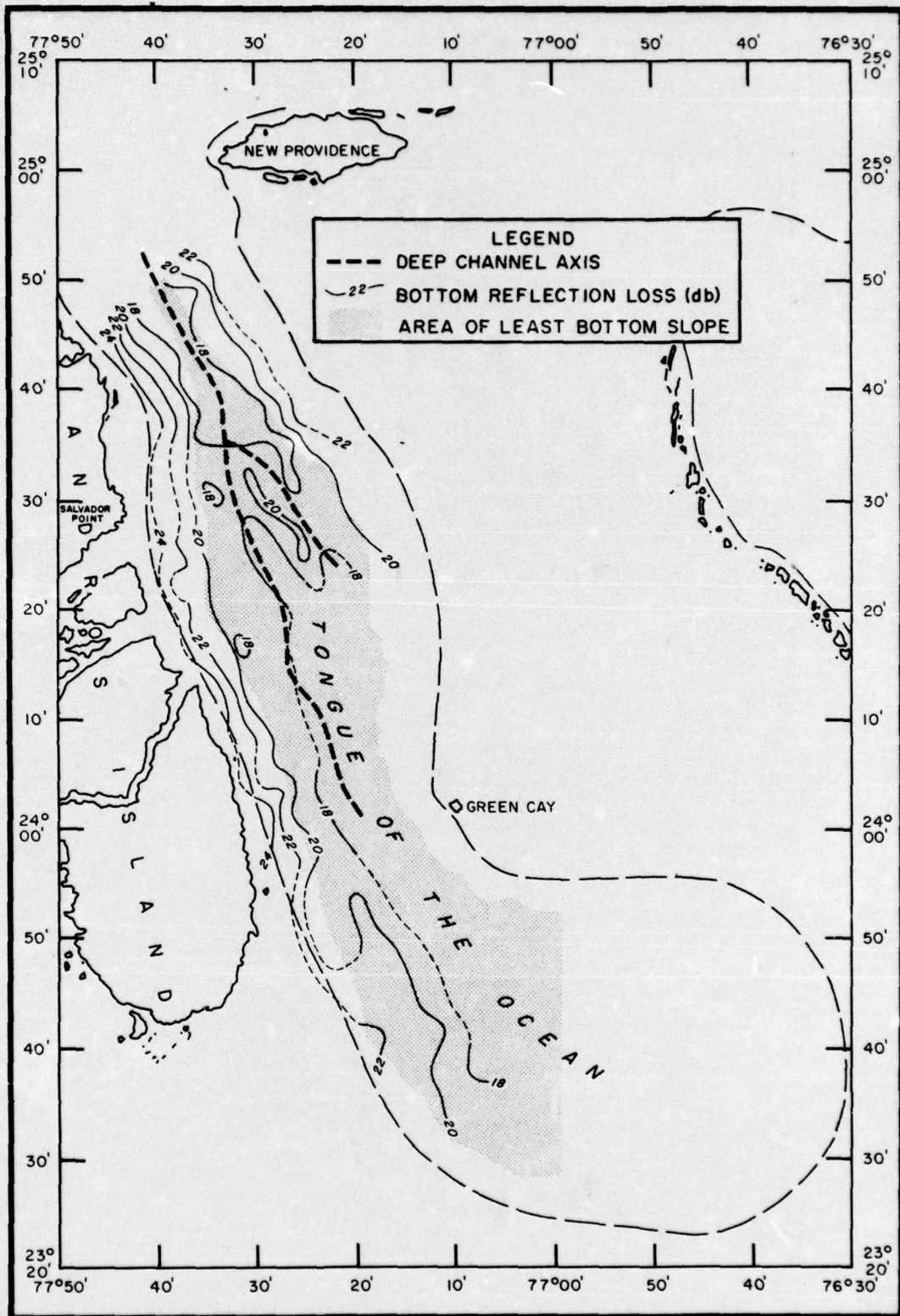

FIGURE 13 BOTTOM LOSS CONTOUR CHART - TOTO

10-15-64

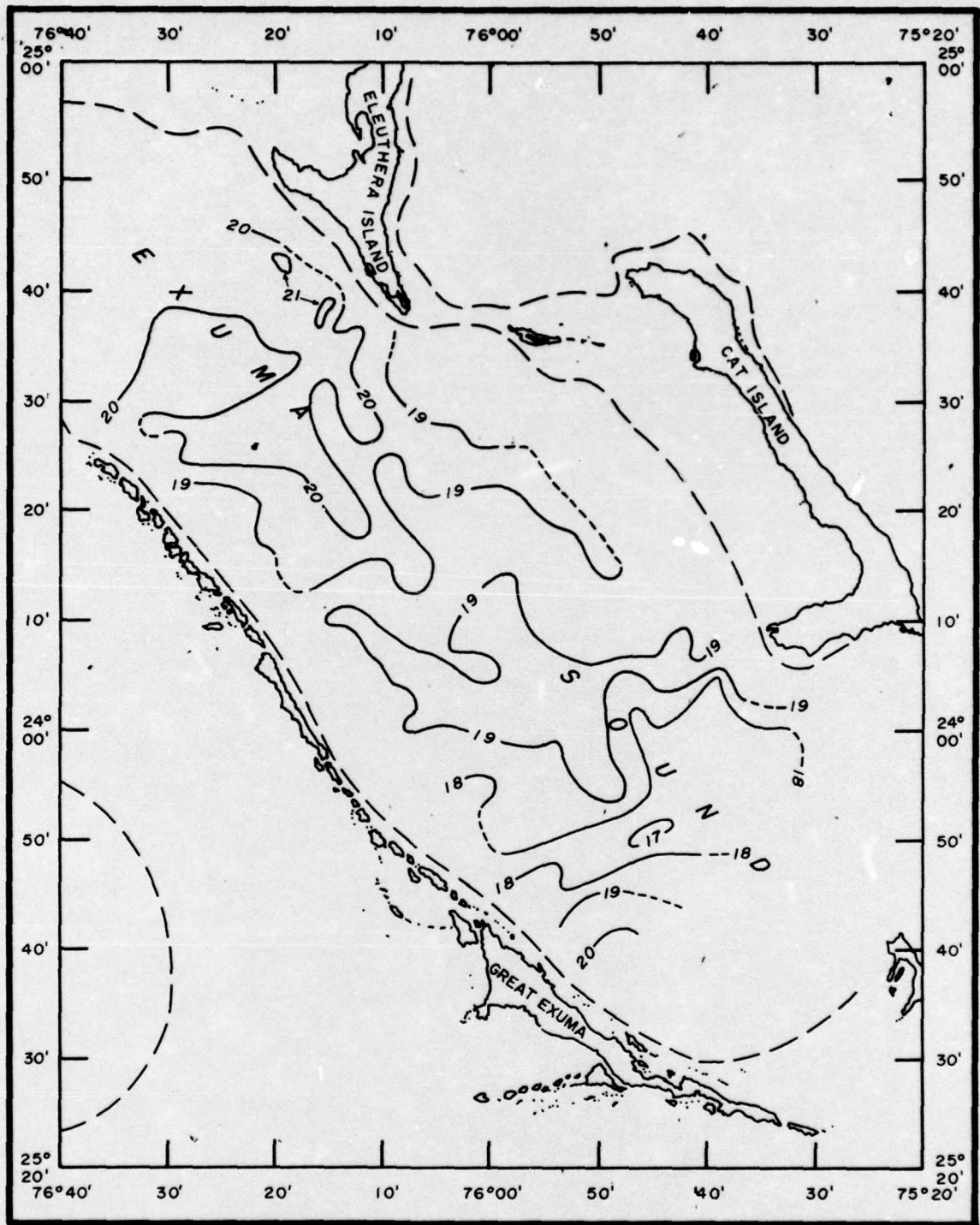

FIGURE 14 BOTTOM LOSS CONTOUR CHART - EXUMA SOUND

0-13-64

the near-vertical escarpment wall inside 600 foot depths, the bottom losses increase to a maximum mean loss of 26.2 db (Station 10, Run 1, Area II). Incidentally, the S-shaped 20-db closure located in the central portion east of Salvador Point appears to be associated with an existing ridge that rises almost 20 fathoms above the surrounding topography. Of the two valleys flanking this rise (and whose axes are indicated by the dash-dot line in Figure 13) the westernmost is the deeper main channel and has side slopes approaching 3 degrees.

Data repeatability was reasonably good in those few instances where tracks overlapped each other. The range of differences between eight sets of stations were from 0.1 db to 1.2 db with an average difference of 0.7 db between stations.

CONCLUSIONS

The separate geographic areas of the TOTO and Exuma Sound exhibit relatively stable and nearly identical bottom loss characteristics - if that portion of the TOTO data obtained over the steeper marginal slopes is discounted. This is clearly proven by comparison of several common statistical measures, i.e. - the mean losses agree to within 0.1 db (19.1 and 19.2), the standard deviations are only 0.4 db apart (0.9 and 1.3), the 95% confidence levels cover essentially the same range (17 to 21 db and 17 to 22 db).

The overall mean loss characteristic of both areas is about 1.5 db higher than the reflection loss (17.6 db) extrapolated from AMOS curves¹⁰ for 12-kc normal incidence and corrected by +6 db for single arrivals. If the AMOS data were adjusted further by applying the same absorption coefficient as used in this report (Winokur⁸ indicated an average difference of about 0.2 db/kyd exists between coefficients) then the difference between the AMOS reflection loss and that presently reported would be less than 1 db.

A definite increase in bottom loss was associated with the increasing marginal slopes of the TOTO. Although no exact determination of this effect could be made, an approximation indicates an increase in loss of 2 to 4 db per mile over slopes averaging 12 to 15 degrees and little or no increase in loss over slopes less than 3 degrees.

A possible indicator that statistically relates increased bottom loss to increased bottom slope is the measure of right skewness of the frequency distributions. These data show that above the upper limit of the 95% confidence level (21 db) there exists an approximate relationship of 1 db increase in loss for each 0.1 unit increase in skewness.

REFERENCES

1. U. S. Naval Oceanographic Office, *Bottom Loss in the Tongue of the Ocean - Spring 1962, Part I: Weapons Range*, NAVOCEANO IMR No. 0-42-63, December 1963, Unpublished Manuscript.
2. - - - *Bottom Loss in the Tongue of the Ocean - Spring 1962, Part II: Acoustic Range*, NAVOCEANO IMR No. 0-59-63, January 1964, Unpublished Manuscript.
3. Halvorsen, R. A., *Bottom Loss and Related Phenomena in the Tongue of the Ocean*, AVCO Marine Electronics Office, June 1963.
4. Commander Destroyer Development Group, Pacific, *Sound Reflection Measurement in the Pacific*, September 1961. (CONFIDENTIAL)
5. U. S. Naval Oceanographic Office, *Tables of Sound Speed in Sea Water*, Special Publication SP-58, August 1962.
6. Schulkin, M. and H. W. Marsh, *Letter on Absorption Constant*, *Journal of the Acoustical Society of America*, Vol. 34, No. 6, p. 864, June 1962.
7. Winokur, R. S. and L. C. Breaker, *Reflectivity Measurements in Pacific Area G*, U. S. Naval Oceanographic Office IMR No. 0-101-63, January 1963, Unpublished Manuscript. (CONFIDENTIAL)
8. Winokur, R. S., *Normal Incidence Bottom Reflection Measurements in Atlantic Area C₁*, U. S. Naval Oceanographic Office IMR No. 0-114-63, June 1963, Unpublished Manuscript. (CONFIDENTIAL)
9. Athearn, W. D., *Bathymetry of the Straits of Florida and the Bahama Islands, Part II, Bathymetry of the Tongue of the Ocean, Bahamas*, *Bulletin of Marine Science of the Gulf and Caribbean*, Vol. 13, No. 3 September 1963.
10. Marsh, H. W. and M. Schulkin, *Sound Transmission of Frequencies between 2 and 25 kilocycles per second (Revised)*, U. S. Navy Underwater Sound Laboratory Technical Memorandum No. 1110-110-54, August 1954.

