

AD-A033 292

GEORGIA INST OF TECH ATLANTA ENGINEERING EXPERIMENT --ETC F/6 20/14
ELECTROMAGNETIC COMPATIBILITY RATIONALE REPORT: RADIATED TEST R--ETC(U)
APR 76 J C TOLER, J A WOODY

UNCLASSIFIED

FAA/RD-76-70

DOT-FA74WA-3372

NL

1 OF 3
AD
A033292

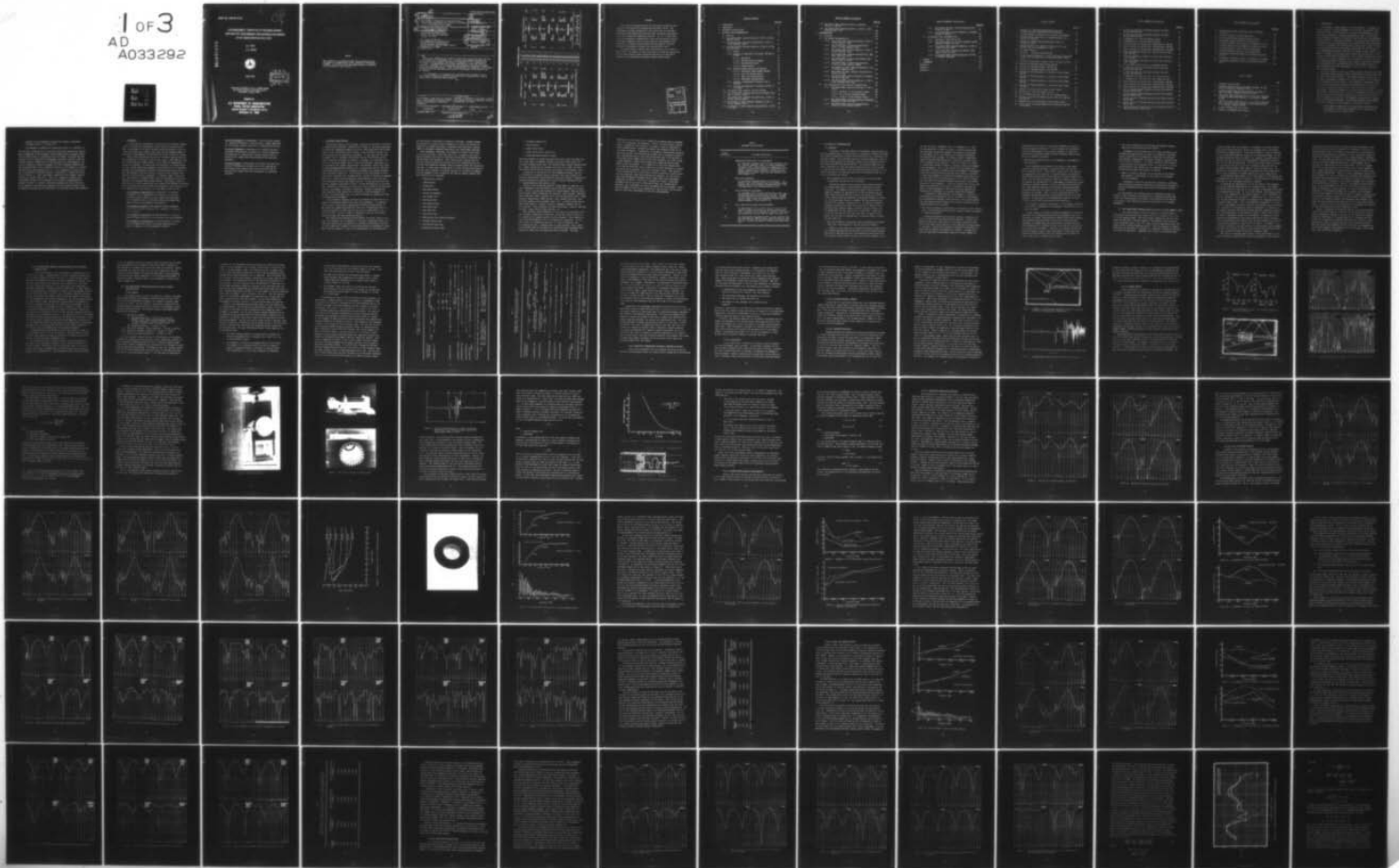

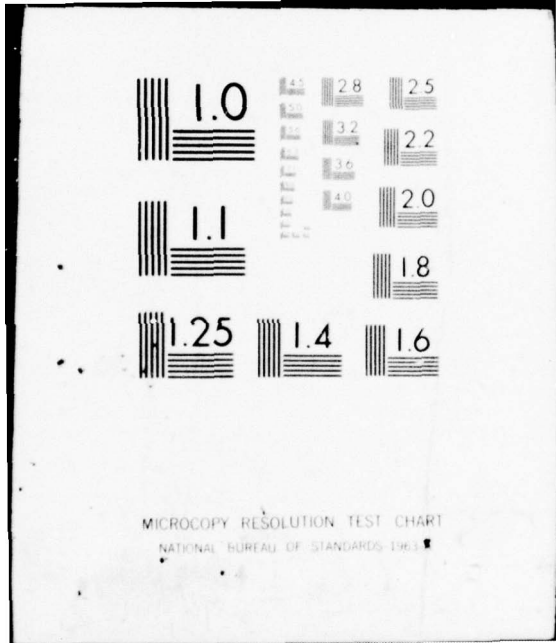

MICROCOPY RESOLUTION TEST CHART
NATIONAL BUREAU OF STANDARDS-1963

Report No. FAA-RD-76-70

12

**ELECTROMAGNETIC COMPATIBILITY RATIONALE REPORT:
RADIATED TEST REQUIREMENTS FOR ELECTRONIC EQUIPMENTS
IN AIR TRANSPORTATION FACILITIES**

ADA033292

J. C. Toler
J. A. Woody



April 1976

DDC
RECEIVED
DEC 14 1976
A

Document is available to the U.S. public through
the National Technical Information Service,
Springfield, Virginia 22161.

Prepared for
U.S. DEPARTMENT OF TRANSPORTATION
FEDERAL AVIATION ADMINISTRATION
Systems Research & Development Service
Washington, D.C. 20580

NOTICE

This document is disseminated under the sponsorship of the Department of Transportation in the interest of information exchange. The United States Government assumes no liability for its contents or use thereof.

DOT/0333012

18. Report No. FAA/RD-76-70	2. Government Accession No.	3. Recipient's Catalog No. 11	
16. Title and Subtitle Electromagnetic Compatibility Rationale Report: Radiated Test Requirements for Electronic Equipments in Air Transportation Facilities		4. Report Date April 1976	6. Performing Organization Code
7. Author(s) J. C. Toler and J. A. Woody		8. Performing Organization Report No. 12 226p.	
9. Performing Organization Name and Address Engineering Experiment Station Georgia Institute of Technology Atlanta, GA 30332		10. Work Unit No. (if any)	11. Contract or Grant No. DOT-FA74WA-3372
12. Sponsoring Agency Name and Address U.S. Department of Transportation Federal Aviation Administration Systems Research and Development Service Washington, D.C. 20590		13. Type of Report and Period Covered Research Rept.	
14. Sponsoring Agency Code ARD-350		15. Supplementary Notes	
16. Abstract This report summarizes the technical efforts and conclusions resulting from an investigation of requirements for a radiated electromagnetic emission and susceptibility test standard applicable to equipments in air transportation facilities. Recommendations are provided regarding the tests that should be performed, acceptable test configurations and procedures, applicable frequency ranges and performance limits. These recommendations are documented in the format of Federal Aviation Administration notices to be attached to MIL-STD-461A and MIL-STD-462. The recommended test configurations, procedures and performance limits, when properly imposed on equipment procedures, will be manifested as improved flight safety, scheduling, and reliability.			
17. Key Words Electromagnetic Compatibility, Radiated Tests, Electromagnetic Emission, Electromagnetic Susceptibility, Electronic Equipments		18. Distribution Statement Document is available to the public through the National Technical Information Service, Springfield, VA 22161	
19. Security Classif. (of this report) Unclassified	20. Security Classif. (of this page) Unclassified	21. No. of Pages 226	22. Price

153850

JP

METRIC CONVERSION FACTORS

Approximate Conversions to Metric Measures

Symbol	When You Know	Multiply by	To Find	Symbol
LENGTH				
m	inches	2.5	centimeters	cm
ft	feet	30	centimeters	cm
yd	yards	0.9	meters	m
mi	miles	1.6	kilometers	km
AREA				
m ²	square inches	6.5	square centimeters	cm ²
ft ²	square feet	0.09	square meters	m ²
yd ²	square yards	0.8	square meters	m ²
mi ²	square miles	2.6	square kilometers	km ²
acres	acres	0.4	hectares	ha
MASS (weight)				
oz	ounces	28	grams	g
lb	pounds	0.45	kilograms	kg
	short tons (2000 lb)	0.9	metric tons	t
VOLUME				
cup	teaspoons	5	milliliters	ml
fl oz	tablespoons	15	milliliters	ml
c	fluid ounces	30	milliliters	ml
pt	cup	0.24	liters	l
qt	quarts	0.97	liters	l
gal	gallons	3.8	liters	l
cu ft	gallons	3.8	liters	l
cu yd	cubic feet	0.76	cubic meters	m ³
cu yd	cubic yards	0.76	cubic meters	m ³
TEMPERATURE (exact)				
°F	Fahrenheit temperature	5/9 after subtracting 32	Celsius temperature	°C

Approximate Conversions from Metric Measures

Symbol	When You Know	Multiply by	To Find	Symbol
LENGTH				
mm	millimeters	0.04	inches	in
cm	centimeters	0.4	inches	in
m	meters	3.3	feet	ft
km	kilometers	1.1	yards	yd
		0.6	miles	mi
AREA				
cm ²	square centimeters	0.16	square inches	in ²
m ²	square meters	1.2	square yards	yd ²
km ²	square kilometers	0.4	square miles	mi ²
ha	hectares (10,000 m ²)	2.5	acres	acres
MASS (weight)				
g	grams	0.035	ounces	oz
kg	kilograms	2.2	pounds	lb
t	metric tons (1000 kg)	1.1	short tons	short tons
VOLUME				
ml	milliliters	0.03	fluid ounces	fl oz
l	liters	2.1	pints	pt
l	liters	1.06	quarts	qt
m ³	cubic meters	0.26	gallons	gal
m ³	cubic meters	35	cubic feet	ft ³
m ³	cubic meters	1.3	cubic yards	yd ³
TEMPERATURE (exact)				
°C	Celsius temperature	9/5 (then add 32)	Fahrenheit temperature	°F

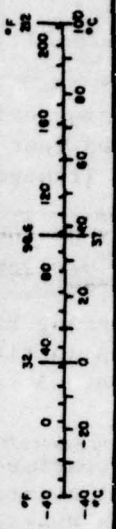
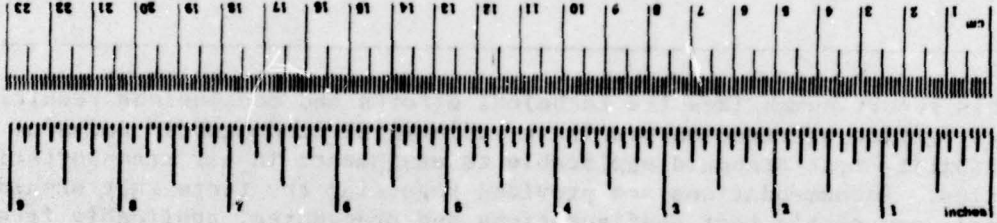

* 1 in = 2.54 exactly. For other exact conversions and more data, see: see NBS Misc. Publ. 286, Units of Length and Measure, N of 22-25, N of 22-26, N of 22-27, N of 22-28.

FOREWORD

This report was prepared within the Electronics Technology Laboratory of the Georgia Tech Engineering Experiment Station. The investigation results documented by this report were in accordance with Contract DOT-FA74WA-3372 and were under the general supervision of Mr. D. W. Robertson, Laboratory Director. Mr. J. C. Toler, Head of the Electromagnetic Compatibility Group, was the Project Director. This report summarizes the activities directed to developing recommendations for Federal Aviation Administration adoption regarding radiated electromagnetic emission and susceptibility tests.

The authors wish to express their appreciation to Mr. Richard S. Smith and Mr. Lee DeHart for their assistance in conducting evaluations on the various hooded antenna configurations and to Mr. Bernard M. Jenkins for his consultation regarding hooded antenna design.

ACCESSION BY	
HTS	White Section <input checked="" type="checkbox"/>
BSC	Buff Section <input type="checkbox"/>
UNANNOUNCED	<input type="checkbox"/>
JUSTIFICATION	
BY	
DISTRIBUTION AVAILABILITY CODES	
Dist.	AVAIL. CODE OR SPECIAL
A	

TABLE OF CONTENTS

	<u>PAGE NO.</u>
1. INTRODUCTION	1
2. TERMINOLOGY	3
3. EQUIPMENT CLASSIFICATION.	5
4. RATIONALE FOR RECOMMENDATIONS	11
4.1 Approach	11
4.2 Test Method RE01, Radiated Emission, 30 Hz to 30 kHz, Magnetic Field	14
4.3 Test Method RS01, Radiated Susceptibility, 30 Hz to 30 kHz, Magnetic Field	17
4.4 Test Method RE02, Radiated Emission, 14 kHz to 10 GHz, Electric Field	18
4.4.1 General	18
4.4.2 Analysis of Measurement Procedures (400 MHz to 10 GHz)	23
4.4.2.1 Open-Field	24
4.4.2.2 Shielded Anechoic Chamber.	25
4.4.2.3 Shielded Enclosures.	25
4.4.2.4 Hooded Antenna	28
4.4.3 Extended Hooded Antenna Investigation	38
4.4.3.1 Adjustable Length Hooded Antenna	40
4.4.3.2 Four Inch Hooded Antenna	43
4.4.3.3 Eight Inch Hooded Antenna.	67
4.4.3.4 Additional Considerations.	77
4.4.4 Analysis of Measurement Procedures (30 to 400 MHz).	88
4.4.5 Analysis of Measurement Procedures (14 kHz to to 30 MHz).	91
4.5 Test Method RS02, Magnetic Induction Fields.	92
4.6 Test Method RE03, Radiated Spurious and Harmonic Emission, 10 kHz to 40 GHz.	95
4.7 Test Method RS03, Radiated Susceptibility, 14 kHz to 10 GHz, Electric Field	96
4.8 Test Method (T) RE04, Radiated Emissions, 20 Hz to 40 kHz, Magnetic Field	98
4.9 Test Method (T) RS04, Radiated Susceptibility, 14 kHz to 30 MHz.	98

TABLE OF CONTENTS (Continued)

	<u>PAGE NO.</u>
4.10 Test Method RE05, Radiated Emission, Broadband, 150 kHz to 1000 MHz	99
4.11 Test Method RE06, Radiated Emission, 14 kHz to 1 GHz, Overhead Power Lines.	100
5. RECOMMENDATIONS	103
5.1 Overview.	103
5.2 Test Method Recommendations	103
5.2.1 Test Method RE01, Radiated Emissions, 30 Hz to 30 kHz, Magnetic Field.	103
5.2.2 Test Method RS01, Radiated Susceptibility, 30 Hz to 30 kHz, Magnetic Field	104
5.2.3 Test Method RE02, Radiated Emission, 14 kHz to 10 GHz, Electric Field.	105
5.2.4 Test Method RS02, Radiated Susceptibility, Mag- netic Induction Fields.	106
5.2.5 Test Method RE03, Spurious and Harmonic Emis- sions, 10 kHz to 40 GHz	106
5.2.6 Test Method RS03, Radiated Susceptibility, 14 kHz to 10 GHz, Electric Fields	107
5.2.7 Test Method (T) RE04, Radiated Emissions, 20 Hz to 50 kHz, Magnetic Field	107
5.2.8 Test Method (T) RS04, Radiated Susceptibility, 14 kHz to 30 MHz.	107
5.2.9 Test Method RE05, Radiated Emission, Broadband, 150 kHz to 1000 MHz	108
5.2.10 Test Method RE06, Radiated Emissions, 14 kHz to 1 GHz, Overhead Power Lines	109
5.3 Test Configuration and Procedure Recommendations. . . .	109
5.3.1 Test Method RE02, Radiated Emissions, 14 kHz to 10 GHz.	109
5.3.1.1 400 MHz to 10 GHz Frequency Range. . .	109
5.3.1.2 30 to 400 MHz Frequency Range.	113
5.3.1.3 14 kHz to 30 MHz Frequency Range . . .	114
5.3.2 Test Method RE03, Radiated Spurious and Harmonic Emissions, 14 kHz to 40 GHz	114
5.3.3 Test Method RS03, Radiated Susceptibility, 30 MHz to 10 GHz, Electric Field.	115

TABLE OF CONTENTS (Continuation)

	<u>PAGE NO.</u>
5.3.4 Test Method (T) RS04, Radiated Susceptibility, 14 kHz to 30 MHz.	116
5.3.5 Test Method RE05, Radiated Emissions, Broadband, 150 kHz to 400 MHz.	116
5.4 Performance Limit Recommendations	116
5.4.1 Approach to Limit Derivation.	116
5.4.2 Test Methods RS03 and (T) RS04, Radiated Susceptibility, 14 kHz to 10 GHz.	117
5.4.3 Test Method RE02, Radiated Emissions, 14 kHz to 10 GHz, Electric Field.	121
5.4.4 Test Method RE03, Spurious and Harmonic Emissions, 14 kHz to 40 GHz	128
5.4.5 Test Method RE05, Radiated Emissions, 150 kHz to 400 MHz, Broadband	130
6. SUMMARY	131
7. REFERENCES.	137
APPENDIX A.	A-1
APPENDIX B.	B-1
APPENDIX C.	C-1

LIST OF FIGURES

	<u>PAGE NO.</u>
1. Diagram of a Conventional Measurement Setup in a Shielded Enclosure Showing Multiple Signal Paths	27
2. Coupling Between Two Antennas As A Function of Frequency	27
3. Coupling Between Antennas in a Shielded Enclosure as a Function of Spacing.	29
4. Diagram of a Hooded Antenna Measurement Setup in a Shielded Enclosure	29
5. Antenna Patterns of an Eighteen Inch Dish with a Log-Periodic Feed at a Frequency of 2 GHz.	30
6. UHF Hooded Antenna	33
7. Two Views of Microwave Hooded Antenna.	34
8. Coupling Between Antennas at 1 Meter Separation, Normalized to Open Field Coupling, Over the Frequency Range 1 MHz to 10 GHz	35
9. Theoretical Beam Width of Hooded Antenna vs Aperture Size.	37
10. Diagram of Adjustable-Length Hooded Antenna.	37
11. Patterns for Unhooded Antenna, 200-500 MHz	41
12. Patterns for Unhooded Antenna, 600-1000 MHz.	42
13. Patterns for Hooded Antenna as a Function of Hood Length, 400 MHz.	44
14. Patterns for Hooded Antenna as a Function of Hood Length, 600 MHz.	45
15. Patterns for Hooded Antenna as a Function of Hood Length, 800 MHz.	46
16. Patterns for Hooded Antenna as a Function of Hood Length, 1000 MHz	47
17. Beamwidth as a Function of Hooded Antenna Length	48
18. Photograph of 4-1/8 Inch Hooded Antenna.	49
19. Gain and VSWR Curves for the 4-1/8 Inch Hooded Antenna	50
20. Patterns for 4-1/8 Inch Hooded Antenna, Nine Foot Spacing, 400-1000 MHz	52
21. Beamwidth of 4 Inch Adjustable Length Hooded Antenna	53
22. Gain of 4-1/8 Inch Hooded Antenna with Separation Distance of One Meter	53

LIST OF FIGURES (Continuation)

	<u>PAGE NO.</u>
23. E_{ϕ} Patterns for 4-1/8 Inch Hooded Antenna, One Meter Spacing, 400-1000 MHz	55
24. E_{θ} Patterns for 4-1/8 Inch Hooded Antenna, One Meter Spacing, 400-1000 MHz	56
25. E_{ϕ} Beamwidth for 4-1/8 Inch Hooded Antenna.	57
26. E_{θ} Beamwidth for 4-1/8 Inch Hooded Antenna.	57
27. Dipole Patterns for Various Test Configurations, 600 MHz.	59
28. Dipole Patterns for Various Test Configurations, 800 MHz.	60
29. Dipole Patterns for Various Test Configurations, 1000 MHz	61
30. Simulated Equipment Patterns for Various Test Configurations, 600 MHz.	62
31. Simulated Equipment Patterns for Various Test Configurations, 800 MHz.	63
32. Simulated Equipment Patterns for Various Test Configurations, 1000 MHz	64
33. Gain and VSWR Curves for 8-1/2 Inch Hooded Antenna.	68
34. E_{ϕ} Patterns for 8-1/2 Inch Hooded Antenna, One Meter Spacing, 500-1000 MHz	69
35. E_{θ} Patterns for 8-1/2 Inch Hooded Antenna, One Meter Spacing, 500-1000 MHz	70
36. E_{ϕ} Beamwidth for 4-1/8 and 8-1/2 Inch Hooded Antennas	71
37. E_{θ} Beamwidth for 4-1/8 and 8-1/2 Inch Hooded Antennas	71
38. Dipole Patterns for Various Test Configurations, 600 MHz.	73
39. Dipole Patterns for Various Test Configurations, 800 MHz.	74
40. Dipole Patterns for Various Test Configurations, 1000 MHz	75
41. Dipole Patterns in Bare Shielded Enclosure with Unhooded Antenna, 498-501 MHz.	79
42. Dipole Patterns in Bare Shielded Enclosure with Unhooded Antenna, 898-901 MHz.	80
43. Dipole Patterns in Shielded Enclosure with Hooded Antenna, 498-501 MHz	81
44. Dipole Patterns in Shielded Enclosure with Hooded Antenna, 898-901 MHz	82
45. Dipole Pattern Variations for 8-1/2 Inch Hooded Antenna in Shielded Enclosure, 698-704 MHz	83

LIST OF FIGURES (Continuation)

	<u>PAGE NO.</u>
46. Standing Waves Along Longitudinal Axis of Shielded Enclosure	85
47. Shielded Enclosure Field Distributions.	87
48. Representative Hooded Antenna Design Features	111
49. Recommended Hooded Antenna Test Configuration	112
50. Narrowband Emission Levels Measured in ARTCC Facilities . .	119
51. Broadband Emission Levels Measured in ARTCC Facilities. . .	120
52. Narrowband Emission Limits for Test Method RE02	123
53. Broadband Emission Limits for Test Method RE02.	124
54. Recommended Transmitter Spurious and Harmonic Emission Limits.	129
55. Recommended Performance Limits for Radiated Test Methods. .	133
56. Recommended Transmitter Spurious and Harmonic Emission Limits.	134

LIST OF TABLES

	<u>Page</u>
I. EQUIPMENT CLASSIFICATION	9
II. FREQUENCY RANGES OVER WHICH AUTOMATED EQUIPMENT IN ARTCC FACILITIES EXCEEDED APPLICABLE LIMITS.	21
III. FREQUENCY RANGES OVER WHICH NON-AUTOMATED EQUIPMENT IN ARTCC FACILITIES EXCEEDED APPLICABLE LIMITS.	22
IV. CORRELATION COEFFICIENTS FOR THE 4-1/8 INCH HOOD COMPARING PATTERNS OF THREE CONFIGURATIONS TO THE ANECHOIC CHAMBER PATTERN.	66
V. CORRELATION COEFFICIENTS FOR THE 8-1/2 INCH HOOD COMPARING TUNED HORIZONTAL DIPOLE PATTERNS OF THREE CONFIGURATIONS TO THE ANECHOIC CHAMBER PATTERN.	76
VI. SUITABLE ANTENNAS FOR USE IN HOODS	110
VII. SUMMARY OF RECOMMENDED TEST METHODS.	132

1. INTRODUCTION

The movement of large numbers of persons traveling for pleasure and business purposes is highly dependent on a safe and efficient air transportation system. This system must be capable of accommodating an estimated annual increase in traveler enplanements of eight to nine percent and an increase in production of general aviation aircraft that approaches 10,000 yearly [1]. Using these estimates, air transportation forecasters now predict that air transportation in the United States could increase by as much as six percent per year and thereby double over the next 12 years. Concerns resulting from these estimates include the fact that there are no corresponding indications that either the number of major airports, the number of runways, the altitude range available for aircraft use, or the amount of radio spectrum allocated air traffic control purposes will double. Consequently, the future appears to offer a situation in which a continually increasing number of travelers will attempt to use an air transportation system that (1) is already operating at near maximum capacity in many instances and (2) will experience at best a low rate of expansion over the next decade.

With this situation in mind, the Federal Aviation Administration (FAA) has undertaken numerous efforts aimed at maintaining the current high level of flight safety and reliability. This research program, directed to developing Electromagnetic Compatibility control documents for FAA adoption, is representative of these efforts. Electromagnetic Compatibility (EMC) is a technical discipline concerned with electromagnetic performance degradation of electronic devices as they function in their operational environment. Under this program, the research objective has been to develop EMC documentation that can be (1) used as a FAA management guide in establishing an effective EMC control program and (2) contractually imposed on FAA procurements to assure that electromagnetic design and test requirements are adequately considered. The developed documents have numbered four and, in addition to this document, are titled as follows:

- Electromagnetic Compatibility Rationale Report--Conducted Test Requirements for Electronic Equipments in Air Transportation Facilities, Report No. FAA-RD-76-69.

- Handbook for Electromagnetic Compatibility Design of Electronic Equipments, Report No. FAA-RD-76-71.
- Electromagnetic Compatibility Program Plan, Report No. FAA-RD-76-75.

This document, concerned with the rationale supporting radiated test requirements recommended for FAA equipment, was developed during a research effort that included surveys of representative FAA facilities, interviews with FAA personnel in both operational and management positions, analyses of FAA procurement methods, classification of FAA equipment into electromagnetic criticality categories, technical exchanges with other government agencies with EMC responsibilities, and an intensive evaluation of the adequacy of currently imposed military EMC standards [2], [3]. It is organized to provide a glossary of applicable terminology (Section 2) immediately following this introduction (Section 1). Next, applicable documents and the equipment classifications are provided (Section 3). Then, the rationale for radiated test requirements (Section 4) is presented and test method recommendations are provided (Section 5). Finally, referenced documents are listed (Section 6) and an appendix is provided that stipulates editorial modifications by which recommended procedures may be incorporated into existing military EMC standards.

2. TERMINOLOGY

A clearly defined terminology is essential to the efficient communication of concepts and requirements in any technical discipline area. This is particularly true within the EMC discipline because of both the similarity between many commonly used terms and the expanding number of areas where electromagnetic interactions have become a matter of concern.

Numerous EMC terminologies for specific technical applications have been documented, but because of their narrow range of applicability, they have often tended to become a barrier to the effective communication of broader EMC concerns. To assure that this difficulty is avoided within the FAA, the EMC terminology presented in MIL-STD-463 [4] is recommended. Although this terminology is directed to military applications, there is more than adequate functional overlap to permit an easy transfer from military to FAA electronic equipments. To expedite usage of this document, definitions of fundamental EMC terms are transferred from military language to FAA language and presented herein. Additionally, technical terms peculiar to this document and not included in MIL-STD-463 are defined. These definitions plus those in MIL-STD-463 provide a sufficient base for the communication of EMC concepts and requirements within the FAA.

Electromagnetic Compatibility--The capability of electronic equipments in air transportation facilities to operate, with a defined margin of safety, in their operational environment and at designed levels of efficiency without performance degradation due to electromagnetic interactions.

Electromagnetic Emission--Electromagnetic energy propagated from source via either radiation (air coupling) or conduction (wire coupling).

Electromagnetic Interference--The manifestation of an electromagnetic emission incident on a susceptible electronic equipment.

Electromagnetic Susceptibility--The characteristic of an electronic equipment that permits performance degradation as a result of exposure to an electromagnetic emission.

Electronic Equipment--An assemblage of circuit devices mounted in a chassis and designed to perform either a signal generation or conditioning function within an air transportation facility.

Electronic Subsystem--A configuration of multiple electronic equipments interconnected via either air or wire coupling and performing an air transportation facility function that is generally more complex than that performed by an individual equipment.

Electronic System--A configuration of multiple electronic subsystems interconnected via either air or wire coupling and performing an air transportation facility function that is generally more complex than that performed by an individual subsystem.

3. EQUIPMENT CLASSIFICATION

During early phases of this program, attention was directed to the matter of establishing an equipment classification listing for use during subsequent considerations regarding equipment criticality versus applicable test methods. However, prior to adopting such a listing, it was necessary to define more precisely what was to constitute an equipment. It was noted that the term "equipment" was not defined in MIL-STD-463 and that MIL-STD-461A and MIL-STD-462 generally considered an equipment to consist of an individual electrical or electronic chassis with its associated cabling. Essentially, all of the figures (for example, Figure RE02-1, MIL-STD-462, Typical Test Setup for Radiated Measurements) depicting test configurations show an individual chassis positioned on top of a workbench and bonded to the ground reference plane covering the bench top. It was noted that the 1958 version of MIL-I-26600 shows a radiated test configuration for a group of individual equipments mounted in a single rack and supposedly interconnected in such a way that they collectively perform some single function. It was also noted that the specific equipment names given in Table I of MIL-STD-461A were, for the most part, indicative of electrical and electronic devices housed in an individual chassis. For example, receivers, transmitters, counters, oscilloscopes, power supplies, signal generators, auto-pilots, flight instruments, arc welders, electrical gauges, etc. are typical listings for communication and non-communication equipments.

In one instance, computers and digital equipments are mentioned as examples of non-antenna communication-electronic equipments. In reviewing other sources of information regarding MIL-STD-461A and MIL-STD-462, it was noted that figures depicting the various test configurations were described as tending "to imply that the test item is either small (e.g., a few cubic feet \approx 0.1 m^3 , or less) or consists of only one or two black boxes with power and interconnecting cables [5].

The figures in MIL-STD-461A and MIL-STD-462, therefore, convey a concept of an equipment as an assemblage of electronic components housed in an individual chassis and interconnected to perform an identifiable function. If this concept were extended, a system would become an assemblage of equipments typically housed in a multi-rack configuration and interconnected to

perform multiple interrelated or sequential functions. Somewhat between the extremes of a single chassis equipment and a multi-rack system configuration of chassis would exist a subsystem level involving a limited number of individual equipments performing a few identifiable functions.

When equipments, subsystems, and systems were viewed in this sense and surveys were made of major FAA facilities, it became obvious that a high percentage of the critical electronic devices must be classified as systems rather than equipments. This classification resulted from the fact that these electronic devices were multi-rack configurations of extensively interconnected equipments which performed complex and interrelated functions. In most cases, the name given to these configurations indicated that they were considered to represent systems, not individual equipments. A typical example of such a system was the Central Computer Complex (CCC) that consisted of the following:

- System Control Console
- Computing Unit
- Storage Unit
- High Speed Printer
- Printer and Keyboard
- Disk Storage Unit
- Time Source Unit
- Data Receiver Group
- Data Control Unit
- Tape Drive Unit
- Tape Control Unit
- Random Access Plan Position Indicator
- Interface Control Unit
- Card Read and Punch Unit
- Input/Output Control Unit

- Peripheral Adapter Unit
- Switching Unit
- Flight Strip Printer
- Flight Strip Printer Control Unit
- System Maintenance Monitor Console

Additional examples of system configurations would include the Radar Display System (RDS), the Remoter Transmitter/Receiver (RTR) System, the Instrument Landing System (ILS), the Automated Radar Terminal System (ARTS), etc. These systems are not consistent with the "test items" for which MIL-STD-461A and MIL-STD-462 provide test methods and performance limits.

Discussions of this matter with FAA management personnel resulted in a directive to consider devices consistent with those presently addressed by MIL-STD-461A and MIL-STD-462 during this program. Subsequently, standards applicable to system level devices could be developed by FAA if a demonstrated need was shown to exist.

Surveys of FAA facilities revealed a large number of electronic devices conforming to the MIL-STD-461A and MIL-STD-462 concept of an equipment. Typical of these were numerous Very High Frequency (VHF) and Ultra-High Frequency (UHF) transmitters and receivers, tape recorders, regulated output amplifiers (ROA), teletype units, time code generators (TCG), backup emergency communication (BUEC) devices, radio frequency monitors, inner and outer markers, ground movement radars, etc. In addition there was an appreciable number of standard electronic equipments commonly used for test purposes. These equipments included oscilloscopes, counters, spectrum analyzers, signal sources, power supplies, etc.

When analyzing these equipments for the purpose of developing a suitable equipment classification procedure, efforts were made to conform to the classification commonly used by facility personnel. This classification separated equipments into the following four categories: (1) communications, (2) automated processing, (3) electro-mechanical, and (4) navigational aids. Although useful for many purposes, this classification scheme could not be adopted for identifying which equipments were required to comply with the applicable EMC test methods. The major

difficulty lay in the fact that a classification method based on equipment type, not utilization, was necessary. Without the type-oriented classification, transmitters and receivers, for example, would be classified in three (communications, automated processing, and navigation aids) of the four above categories. Consequently, an equipment classification patterned after the one used in MIL-STD-461A was adopted and is presented in Table I. Class designations used in this table incorporate some of the features of the classification commonly used by FAA field personnel, yet differ enough to make possible a classification scheme that assigns individual equipments to only one category. It is important to note that numerous electronic devices which must now be classified as either subsystems or systems may qualify as an equipment in the not-to-distant future. This situation results because the use of solid state circuitry continues to reduce device size and, therefore, make bench mounting more feasible. As this occurs, these newly designated equipments must be added under their appropriate designation in Table I. The Class I designation in Table I identifies equipments that are critical to safe and reliable air transportation; therefore, test requirements for these equipments must be stringent. Equipments in Classes II and III are progressively less critical, and the stringency of their test requirements can decline correspondingly.

TABLE I
EQUIPMENT CLASSIFICATION

Class Designation	Equipment Description
I	<p>Communication-Electronic (C-E) Equipments</p> <p>All electronic equipments which in their operation transmit, receive, generate, store, or process information. Included in this classification are transmitters with antennas, receivers with antennas, transceivers with antennas, regulated output amplifiers, backup emergency communication equipment, inner and outer markers, plan view displays, etc.</p>
II	<p>Electronic Equipments</p> <p>All electronic equipments which are not Class I. Included in this classification are oscilloscopes, signal sources, test sets, counters, spectrum analyzers, time code generators, radio frequency monitors, etc.</p>
III	<p>Electro-Mechanical Equipments</p> <p>All equipments which in their operation have both a mechanical and electrical/electronic function. Included in this classification are teletype machines, portable electric tools, repair shop equipment, kitchen and/or lounge equipment, office devices, etc.</p>
IV	<p>Motor Vehicles and Engine-Driven Equipments</p>
IVA	<p>All motor-driven vehicles which in their operation may interrupt normal operations via ignition system radiation. Included are tug vehicles at airports, maintenance and installation vehicles used at remote C-E sites, etc.</p>
IVB	<p>All engine-driven equipments which in their operation may emit interference signals from an ignition system or commutator. Included are gasoline engines, motor-generators, etc.</p>

4. RATIONALE FOR RECOMMENDATIONS

4.1 Approach

In efforts to determine whether FAA equipments required particular types of radiated tests, it was necessary to establish an analysis procedure that assured consideration of major influencing factors in a consistent and systematic manner. This procedure basically involved answering a series of questions while analyzing the technical aspects of test methods currently specified by MIL-STD-461A and MIL-STD-462. The questions asked were not equally applicable to every test method analysis, and no effort was made to treat them as such; however, they provided a satisfactory basis for the analysis procedure. The questions asked and the information base associated with each were as follows:

- What equipments exist at FAA facilities, what are their modes of operation, and how are they installed?

Information relative to this question was obtained primarily via surveys conducted at a representative cross-section of FAA facilities. For example, the Air Route Traffic Control Centers (ARTCC) at Hampton, GA and Nashville, TN were surveyed as was the Flight Service Station (FSS) in Atlanta, GA, and the Air Traffic Control Towers (ATCT) and Terminals at Hartsfield Airport in Atlanta, GA, the International Airport in Memphis, TN, and the Huntsville/Madison County Airport in Huntsville, AL. In addition, surveys of equipment grounding and installation practices at numerous other facilities were conducted under an earlier contract (Contract No. DOT-FA72WA-2850) and were applicable to this effort. These other facilities included the long range radar sites at Aiken, SC and Smyrna, GA, the ATCT at Jacksonville, FL, and the airport at Robins Air Force Base, GA.

- What electromagnetic interference and/or susceptibility problems exist now or have existed in the past in FAA facilities?

Answers to this question were obtained primarily through formal and informal meetings with FAA personnel at the facilities surveyed. Additionally, meetings were held with engineering groups within the FAA Southeast Region Office in Atlanta, GA and with personnel in the

FAA ARD-350 project management office in Washington, D.C. The meetings generally followed the format of technical discussions and interviews during which emphasis was placed on descriptions of the number, nature, and resolution of observed interference and susceptibility problems. The dominate result of these meetings was that most EMC problems are "environment related" and involve transmitters and receivers. There was little or no report of interference, either conducted or radiated, between non-communication equipments. Also, it was learned that the persons interviewed had no definite knowledge of the electromagnetic environment within their facilities and no analyses were planned to determine (1) what electromagnetic influence new equipments might have on the reliable operation of existing equipments or (2) what electromagnetic influence the existing equipments might have on the reliable operation of new equipments. It was also evident that facility and region office personnel have almost no information regarding the extent to which equipments in FAA facilities have complied with radiated test requirements in currently imposed EMC standards.

In addition to interviews with FAA personnel, a limited literature search was conducted to ferret out reports of interference and susceptibility problems at FAA facilities. This search yielded less than twenty relevant reports, most of which reinforced the information obtained via interview.

- What are the technical justifications for the present test requirements in MIL-STD-461A and MIL-STD-462, and what changes are planned in these requirements?

A formal meeting was held with Navy personnel responsible for efforts of the tri-service EMC standards committee to obtain information in this area. Additionally, a subsequent meeting was held with the Air Force representative of this committee to discuss matters in this area. No written or published information delineating jurisdictions for present requirements was obtained. Although firm plans for modifying the existing standards have been underway for

approximately three years, no information regarding the nature of planned changes was available. It was concluded that information justifying requirements in the present standards is either non-existent or is scattered through numerous documents, some of which may not be generally available.

- What are the characteristics of electromagnetic environments in FAA facilities?

This information was obtained from a series of FAA reports prepared by American Electronics Laboratory under Contract No. DOT-FA72-NA-728 [6]-[9]. These reports present data from extensive electromagnetic tests conducted to measure radiated and conducted emission and susceptibility characteristics in selected ARTCC facilities. The facilities surveyed included the centers at Oakland, CA, Los Angeles, CA, and New York, NY. Measurement procedures were either verbatim or modified versions of these in MIL-STD-461A and MIL-STD-462. When modified versions of the military standard measurement procedures were used, the technical basis for the modification was generally not provided. Also, it was not indicated whether the equipments tested had complied with applicable portions of any FMC standard. In some cases, the recommendations tended to be inconclusive in that further investigations were suggested.

- Is it feasible to specify performance of electromagnetic emission tests without complementary electromagnetic susceptibility tests, and vice versa?

A major tenet of the EMC philosophy recommended for FAA implementation in the Program Plan dealt with how equipment level test data were to be used. This philosophy requires that, where possible, both emission and susceptibility test data be obtained for each equipment in a manner such that susceptibility characteristics of each equipment can be analyzed relative to the emission characteristics of all other equipments. Therefore, in analyzing the need for particular types of tests, efforts were made to assure that both emission and susceptibility data were obtained over the same frequency range and in the same electrical units.

- What is the rationale for the radiated test methods currently specified by MIL-STD-461A and MIL-STD-462?

Knowledge of this rationale would have been invaluable in determining the applicability of present test methods to FAA needs. However, essentially no documentation presenting this rationale was available; consequently, the extent to which it applies to FAA needs is one of conjecture. In limited instances it was possible to postulate why certain agencies within the Department of Defense desired specific test methods, but the technical considerations underlying the present test methods are unknown.

- Based on a technical analysis of MIL-STD-461A and MIL-STD-462 test methods, to what extent do they appear to be adequate for FAA equipments?

Information in this area was gained by conducting a method-by-method analysis including the applicable modifications stipulated by notices to essentially every test method in MIL-STD-461A and MIL-STD-462.

As noted earlier, the procedure used in determining the need for specific types of radiated tests consisted of answering the above questions while analyzing each test method in MIL-STD-461A and MIL-STD-462. The results of this analysis procedure are presented in the following paragraphs.

4.2 Test Method RE01, Radiated Emission, 30 Hz to 30 kHz, Magnetic Field

The stated purpose of this test method is to measure magnetic field levels from electrical and electro-mechanical equipments over a 30 Hz to 30 kHz frequency range. The test procedure requires the use of a loop sensor and EMI meter to measure magnetic field radiation from "each unit, cable (including control, pulse, IF, video, antenna transmission lines, and power cables), and interconnecting wiring." With the exception of antenna emanations, the procedure is applicable to transmitter fundamental, spurious, and oscillator radiations. Equipments that operate at frequencies above

30 MHz are exempt from this procedure. Performance of the test involves probing each surface and every cable of an equipment with a loop sensor positioned for maximum pickup. A separation distance of seven centimeters is to be maintained between the sensor and the radiating surface. As each equipment surface and cable are probed, the frequency of the EMI meter is scanned from 30 Hz to 30 kHz, and the bandwidth is maintained no greater than 10 Hz at the three dB points. The EMI meter output level is recorded for each surface and cable at critical frequencies associated with the equipment's design (power, power harmonic, local oscillator, etc.) frequencies, at two frequencies of maximum radiation per octave below 200 Hz, and at three frequencies of maximum radiation per octave above 200 Hz.

In MIL-STD-462 modifications, the Air Force (Notice 2) has deleted the requirement for this test in its entirety. The Army (Notice 3, MIL-STD-462) maintains the test requirement essentially verbatim.

In analyzing the applicability of this test method to FAA equipment, several uncertainties regarding the test procedure arose. For example, MIL-STD-462 states that the test is not applicable to equipments "operating" at frequencies above 30 MHz. It is not clear whether this frequency bound refers to the fundamental of the radiated signal or to the "operating" frequency of equipment local oscillators, IF amplifiers, etc. It was assumed that the test method did not apply to equipments with fundamental operating frequencies above 30 MHz. Also, in MIL-STD-461A, paragraphs 5.2.1(a) and 5.2.1(b), requirements for the two different loop sensors (one for emission tests, another for susceptibility tests) are presented. In referring to the figures concerned with effective height and basic construction details, there are obvious errors in the specified figures. These errors are not corrected by subsequent notices to the standards. In addition to uncertainties in interpreting the test method applicability and to technical errors in describing sensor construction, the test procedure also requires simultaneous performance of several difficult tasks. For example, it is necessary according to the test procedure to simultaneously vary the equipment under test through its mode of operation while probing surfaces and/or cables and while scanning the EMI meter frequency range.

The efforts to determine applicability of this test method not only involved trying to understand the technical requirements of the specified

test procedure, but also efforts to establish whether equipments in FAA facilities required tests for radiated field emissions in the 30 Hz to 30 kHz frequency range. Interviews with personnel at a cross-section of FAA facilities and surveys of equipments at these facilities revealed no interference problems attributable to low frequency magnetic field emissions. The only observed emitter of intense magnetic fields at FAA facilities was the 60 Hz commercial power source, and equipments must of necessity be compatible with their primary power. In the Los Angeles ARTCC [10], it was concluded that "no malfunctions of other equipment due to magnetic emissions were found" during a series of extensive radiated emission measurements. Based on a similar measurement series at the New York ARTCC [11], it was concluded that "magnetic field emissions from automated system equipment does not represent a problem area" and that "no malfunctions of automated or non-automated equipment due to magnetic field emissions have occurred." Further, low frequency radiated measurements at the Oakland ARTCC [12] led to the conclusion that since "low levels of emission were found during the test" and "no malfunctions of automated or non-automated equipment due to magnetic field emissions have occurred," magnetic field emission "does not present a problem area." It should be noted that at each of the ARTCC facilities, MIL-STD-461A limits for low frequency magnetic field emissions were exceeded in at least one test location and over some portion of the applicable frequency range. In spite of this, no past malfunctions of equipment were reported and none were observed during the measurement series.

Efforts to determine the technical basis for low frequency magnetic field emission tests required by MIL-STD-461A and MIL-STD-462 were generally unsuccessful; however, in one source [13], abbreviated comments noted that "RE01 tests are intended primarily for equipments and subsystems to be installed in submarines and should not be used for other applications unless specifically required by the procuring activity." This same source also commended that the limits and test procedures for low frequency magnetic field emission tests "do not apply to test items other than those inside submarines."

4.3 Test Method RS01, Radiated Susceptibility, 30 Hz to 30 kHz, Magnetic Field

The stated purpose of this test method is to determine the susceptibility of Class I (communication-electronic) equipments during exposure to radiated magnetic fields in the 30 Hz to 30 kHz frequency range. Equipments of primary concern are receivers, transmitters, counters, oscilloscopes, signal generators, computers, power supplies, etc. and their associated cables and connectors. The test method is not applicable to equipments operating at frequencies greater than 30 MHz. In most respects, the test procedures are a counterpart to those in Test Method RE01; however, several differences (RE01 requires a seven centimeter separation distance between test item and loop sensor, while in this test method, the distance is five centimeters) exist and are unexplained. The test procedure requires that each surface, cable, and connector associated with an equipment be exposed to a magnetic field with a flux density that decreases at a rate of 40 dB per decade from 140 dBpT at 30 Hz to 20 dBpT at 30 kHz. This is accomplished by slowly moving the loop sensor over surfaces, cables, and connectors while scanning the 30 Hz to 30 kHz frequency range and observing performance of the equipment under test. The practical difficulty associated with simultaneously tuning the signal source, moving the loop sensor, tuning the EMI meter used to monitor the exposure field magnitude, adjusting the current through the loop to set the exposure field magnitude, and observing performance of the equipment has been noted [14] by those attempting to perform this test in accordance with the specified procedures.

In modifications to MIL-STD-461A, the Air Force (Notice 3) deleted the requirement for this test in its entirety. The Army (Notice 4) maintained the test method, but made it applicable to airborne surveillance, compass, and data annotation equipments only.

The analysis procedure to determine whether this test method was applicable to FAA equipments followed a course very much like that for Test Method RE01. Personnel at FAA facilities were aware of no past or present interference problems that could be attributed to low frequency magnetic field susceptibility. The measurement series [6]-[9] performed

at the Los Angeles, New York, and Oakland ARTCC facilities used the radiated susceptibility test procedure in Test Method RS02; therefore, no data obtained in accordance with Test Method RS01 are available. Efforts to determine the technical basis for this test revealed only that the limits and test procedures "are generally applicable to Navy equipments that would be used inside submarines, or for airborne ASW equipments of specialized types. Otherwise, RS01 is not applicable to military electronic systems" [15].

4.4 Test Method RE02, Radiated Emission, 14 kHz to 10 GHz,

Electric Field

4.4.1 General

The stated purpose of this test method is to measure narrowband and broadband radiated electromagnetic emissions from electronic, electrical, and electromechanical equipment over a general frequency range of 14 kHz to 10 GHz. The test method is applicable to essentially all radiated emissions (antenna radiations excepted) from equipments, cables, and interconnecting wiring. The frequency ranges of measurement applicability are as follows:

- (i) Electronic equipment -
 - (a) Narrowband emissions - "14 kHz to 10 times the highest used or intentionally generated frequency, or 1 GHz, whichever is greater; however, the measurement frequency shall not exceed 10 GHz."
 - (b) Broadband emissions - 14 kHz to 1 GHz.
- (ii) Electrical equipment, except handtools - 150 kHz to 400 MHz.
- (iii) Electrical equipment, handtools - 150 kHz to 30 MHz.
- (iv) Vehicle and engine accessories - 150 kHz to 1 GHz.

The test procedure requires the use of four different probe antennas (a monopole, a biconical, and two separate conical logarithmic spirals) and their appropriate matching networks to cover the entire frequency range. An EMI meter "capable of measuring the parameters of this standard" is specified for measuring the emissions. Performance of the test involves probing each face of the equipment under test with a loop "to determine the localized area(s) producing maximum emission." The loop must be maintained at

a distance of five centimeters from each surface and oriented for maximum pickup. As each equipment face is probed, the EMI meter is tuned over the 14 kHz to 10 GHz frequency range. The identified areas of maximum radiation are then individually positioned one meter from the applicable probe antenna and the radiated emission test is conducted. While performing this test, no point of the probe antenna is permitted to be closer than one meter to the walls of the shielded enclosure or any obstruction than may be in the enclosure. For each frequency range, the EMI meter is tuned over the entire range and emission levels are recorded "at not less than three frequencies per octave representing the maximum indications within the octave." Also, emission measurements are made at the test sample's critical frequencies (power and its harmonics, local oscillator, RF, etc.). Over the frequency range of 25 to 200 MHz, measurements are made with both vertical and horizontal polarizations of the probe antenna. For all other frequencies, measurements with either vertical or circular polarizations are required.

Notices to MIL-STD-461A and MIL-STD-462 affect this test method only to a slight extent. Both the Air Force (MIL-STD-461A, Notice 3 and MIL-STD-462, Notice 4) add lists of test instrumentation and change the table of equipment to be tested. The Air Force requires radiated emission tests to be conducted on all equipments while the Army provides a detailed list of equipments to be tested. Both the Air Force and the Army modify the probe antenna requirements. The Air Force notice allows the use of antennas other than those specified, if approved by the procuring activity. The Army notice provides a detailed table describing the permissible probe antennas and their manufacturers. The Army (MIL-STD-462, Notice 3) also makes the following modifications:

1. The probe antenna required in locating areas of maximum radiation from equipment faces is changed from a "loop" to a "loop or other suitable sensor."
2. The frequencies at which the equipment faces are to be probed are changed from a continuous scan of the entire frequency range to "frequencies known or calculated to represent worst case interference; or, if no such information is available,

probing shall be performed at no fewer points than one frequency for every two octaves over the frequency range of the test. Automatic scan techniques may be used to scan all sides."

3. The upper test frequency for narrowband measurements is changed from a variable limit depending on the highest used or intentionally generated frequency, but not greater than 10 GHz, to a fixed frequency of 12.4 GHz.
4. The frequency range over which both horizontal and vertical polarizations of the probe antenna are required is changed from the originally required range of 25 MHz to 200 MHz to a 30 MHz to 12.4 GHz range.

In determining the need for this test method for FAA equipments, two major areas of concern existed: (1) the necessity for equipments in FAA facilities to be tested for radiated electric field emissions and (2) the technical problems, with their possible solutions, related to accuracy, reliability, applicability, and repeatability in performing this test as it is presently specified in MIL-STD-461A and MIL-STD-462. The need for this type of test required considerations of several important factors. Interviews with personnel at various FAA facilities as well as surveys of the equipment at these facilities yielded conclusions that limited interference problems were relatable to electric field emissions from equipments or cables in the 14 kHz to 10 GHz frequency range. This was also the general conclusion reached during the extensive series of radiated measurements conducted at the New York [16], Oakland [17], and Los Angeles [18] ARTCC facilities; however, a detailed analysis of the radiation levels measured at each of these facilities showed that emissions repeatedly exceeded the MIL-STD-461A performance limits by significant amounts. These data are summarized in Tables II and III which present frequency ranges over which measured broadband and narrowband emissions were in excess of applicable performance limits. It is noted that, although MIL-STD-461A requires radiated emission tests over the 14 kHz to 10 GHz frequency range, the upper frequency limit for these measurements was 1 GHz. The data summary in these tables shows that both automated and non-automated equipments critical to the safe and efficient operation of ARTCC facilities radiate

TABLE II

FREQUENCY RANGES OVER WHICH AUTOMATED EQUIPMENT IN
ARTCC FACILITIES EXCEEDED APPLICABLE LIMITS

Measurement Type and Location	Frequency Range					
	14 kHz	1 MHz	10 MHz	100 MHz	500 MHz	1 GHz*
Broadband/New York	↔ All Equipment ↔			↔ RDS ↔ ↔ Most CCC ↔ ↔ SMMC ↔	↔ MODEM, some CCC ↔	
Broadband/Oakland		↔ Nearly All Equipment ↔				↔ Most CDC Equipment ↔
Broadband/Los Angeles				↔ Most CCC Equipment ↔		↔ Most CCC Equipment ↔
Narrowband/New York			↔ All Equipments Except MODEM and SMMC ↔			
Narrowband/Oakland				↔ All Equipment Except DAU ↔		
Narrowband/Los Angeles				↔ Nearly All Equipment ↔		
				↔ Most Equipment Except P/K and Card Punch ↔		

*No measurements were made above 1 GHz although MIL-STD-462 requires narrowband tests to 10 GHz.

Note: RDS = Radar Display System SMMC = System Maintenance Monitor Console
 CCC = Central Computer Complex CDC = Computer Display Channel
 DAU = Data Adapter Unit P/K = Printer Keyboard

TABLE III

FREQUENCY RANGES OVER WHICH NON-AUTOMATED EQUIPMENT
IN ARTCC FACILITIES EXCEEDED APPLICABLE LIMITS

Measurement Type and Location	Frequency Range					
	14 kHz	1 MHz	10 MHz	100 MHz	500 MHz	1 GHz*
Broadband/New York		Most Communications and Microwave Equipment	Scan Converter PVD Station etc.	Air Ground Recorder Scan Converter, TTY Bench, etc.		
Broadband/Oakland		All Communications and Microwave Equipment			VHF/UHF Transmitters/Receivers, RML-4 and ATC Beacon	
Broadband/Los Angeles						All Equipment
Narrowband/New York						All Communications, Test and Microwave Equipment
Narrowband/Oakland						All Communications Equipment
Narrowband/Los Angeles						Most Microwave Equipment
Narrowband/Los Angeles						Transmitters/Recorders in Communications Area, RML-3, RML-4, Scan Converter, etc.

*No measurements above 1 GHz were made although MIL-STD-462 requires narrowband tests to 10 GHz.

Note: RML = Refresh Memory Logic
PVD = Plan View Display

IDIOM = Information Display Input Output Machine
TTY = Teletype

significant electric field levels. These levels are, therefore, capable of being coupled into other nearby equipments and/or cables and, thereby, causing performance degradation. This degradation may or may not be recognized by facility personnel, or its effect may be recognized in some interconnected equipment while the cause remains unrecognized. Further, if the effect is recognized, it may be designated a design, installation, interference, environmental (a term heard often during interviews with facility personnel), etc. problem. Nevertheless, the degradation or potential therefor exists within ARTCC facilities as a result of radiated emission levels from equipments and cables. From surveys of equipments and cables in air traffic control towers, flight service stations, airport terminals, etc., there is no basis for suspecting that this same situation does not exist in these facilities as well. This in itself was considered to be a more than adequate basis for requiring FAA equipments to comply with requirements of an electric field radiation test over the 14 kHz to 10 GHz frequency range.

In addition to the performance degradation potential that measurements have shown to exist in ARTCC facilities and are suspected to exist in other FAA facilities, there was an additional basis for requiring equipment compliance with electric field emission requirements. This basis was somewhat philosophical in nature and related to the need to conserve the limited electromagnetic spectrum available for national and international use. The value of this spectrum in economic and technical terms is so vast that it defies definition. Yet, there is significant evidence [19] that this value continues to be reduced by excessive and/or unnecessary radiated emissions. The results are manifested as complete frequency bands which are so polluted that their use as a resource is severely compromised if not negated. This situation was in mind when determining whether FAA equipment distributed in significant numbers throughout the United States should comply with radiated emission test requirements.

4.4.2 Analysis of Measurement Procedures (400 MHz to 10 GHz)

Once it was established that FAA equipments should be tested for electric field radiation levels, the research effort became one of establishing

test methods which would yield accurate, repeatable, and reliable data. That this was an area needing attention is illustrated by the estimate [20] that over 50 sources of measurement error exist and that somewhere between 10 and 30 of these sources will apply during any given test. These errors may be as great as ± 40 dB in magnitude and originate largely from probabilistic rather than deterministic sources. Many factors influence the measurement of electric field emissions, but experience has shown that the principal error contributors can be ranked as follows:

- an undefined test area electromagnetic environment that varies as a function of location, time, and frequency,
- the positioning, mounting, and operation of the equipment under test in a given test area, and
- performance of test equipment when operated by test personnel.

During this research effort, the first two of these contributors to measurement errors were viewed as being interrelated so closely as to be inseparable. Consequently, reduction of measurement errors due to these two sources provided the departure point for this research effort.

Initially, the research began with the MIL-STD-462 requirement that the ambient electromagnetic level during testing, when measured with the test sample de-energized, be at least 6 dB below the allowable specified performance limit. This requirement is necessary to eliminate interactions between external sources (both natural and man-made) and the test sample; however, it generally necessitates that the test be performed in either an open-field, an anechoic chamber, or shielded room area.

4.4.2.1 Open-Field

A true "open-field" is obviously one means by which an adequate test area environment can be provided. An open-field eliminates the adverse effects of nearby objects, such as metal walls, structures, personnel, etc. and is located such that it provides a low ambient electromagnetic test environment. However, realizing such an open-field is very difficult since a reasonably large, flat area free of significant reflecting objects

and externally generated signals is required. In most practical open-field sites, an externally generated ambient electromagnetic environment that varies in time is present and must be accurately defined so its effects can be accounted for in data analysis. Further, susceptibility tests which, by their nature, generate intense electromagnetic fields, must often be conducted on a non-interference basis with emission tests. Because of these requirements, the performance of emission and susceptibility tests at a field site which begins to approach true open-field conditions can be very time consuming, and test costs can be excessive. Furthermore, operation of an open-field test site must take into account unfavorable weather conditions which make test scheduling difficult.

4.4.2.2 Shielded Anechoic Chamber

An alternative to open-field testing is to use a shielded anechoic chamber consisting of a metal-walled enclosure lined with absorbing material. The metal walls will reduce the externally generated electromagnetic environment in the test area and minimize problems associated with unfavorable weather conditions. Concurrently, the absorbing material on the walls will reduce the reflection effects of the metal walls on the accuracy of test data. The major disadvantages of the shielded anechoic chamber are that it provides a relatively small working volume compared to its overall size, and it is relatively expensive.

4.4.2.3 Shielded Enclosures

Radiated emission and susceptibility tests are generally performed in a "bare" shielded enclosure because of the difficulties associated with conducting such tests in either the open-field or in an anechoic chamber. The shielded enclosure provides significant isolation between the test configuration and the external electromagnetic environment and thereby minimizes both the radiation and reception of undesired signals. Also, the shielded enclosure test area is generally less expensive than either an anechoic chamber or an open-field test site. On the other hand, radiated test data obtained during shielded enclosure measurements exhibit significant adverse errors attributable to (1) standing waves, (2) the size and

shape of the enclosure, (3) test configuration location in the enclosure, (4) spacing between the equipment under test and the probe antenna, and (5) the presence of test personnel and equipment in the enclosure. The primary problem is due to standing waves with the other problems either directly or indirectly related thereto.

Since the six conducting walls of a shielded enclosure form an electromagnetic cavity, standing waves will exist within the enclosure at frequencies above the cutoff frequency. For sufficiently high frequencies such that distances between test items within the enclosure or between a test item and the enclosure walls are large relative to a wavelength, far-field conditions can be assumed to exist; hence, standing waves in the enclosure are composed of propagating fields that can be approximated as plane waves. Under these conditions, the standing wave pattern of the electromagnetic fields within the shielded enclosure may be considered as an interference pattern produced by the superposition of various waves reflected from the enclosure walls. Under these conditions, "ray theory" can be used to analyze and interpret the fields. As frequencies more nearly approach the optical range, this approximation becomes more exact.

Figure 1 illustrates a typical measurement configuration in a shielded enclosure and depicts the signal multipath conditions that contribute to inaccurate test results at high frequencies. This figure shows only a fraction of the multiple signal paths that can exist in the shielded enclosure. During previous research efforts [21], [22], extensive measurements have been conducted to define the magnitude of these multipath effects on radiated test results. Figure 2 presents the coupling between two antennas spaced one meter apart in a 8 x 8 x 20 foot shielded enclosure over the 1 MHz to 1 GHz frequency range. These data have been normalized with respect to open-field coupling so that the resulting variations are due only to the presence of the shielded enclosure. From one to approximately 30 MHz, the shielded enclosure results are 2 to 3 dB lower than the open field coupling; however, coupling variations of the order of ± 40 dB with respect to open field coupling are present in the shielded enclosure at measurement frequencies above approximately 30 MHz. Similar variations occur in shielded enclosures of other sizes and configurations and for other antenna separation distances. For example, the coupling between two antennas as a function of

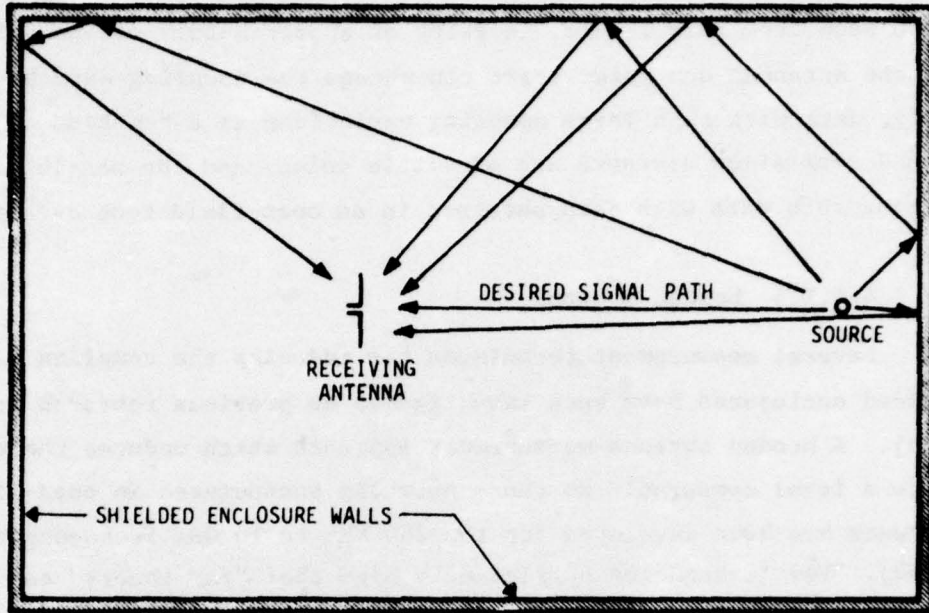

Figure 1. Diagram of a Conventional Measurement Setup in a Shielded Enclosure Showing Multiple Signal Paths.

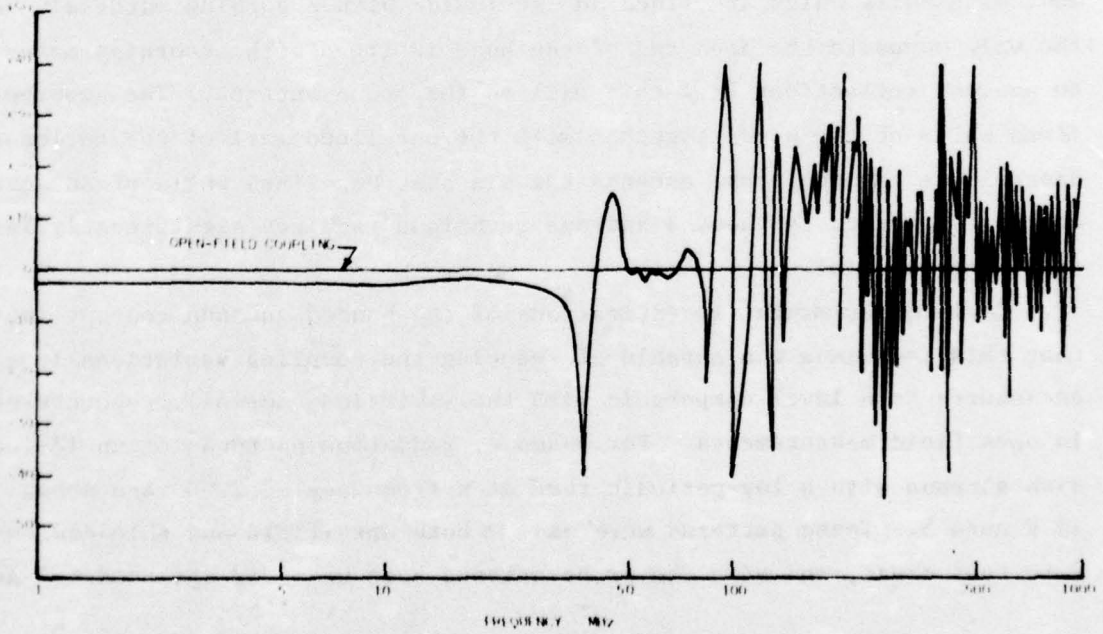

Figure 2. Coupling Between Two Antennas As a Function of Frequency.

separation distance is shown in Figure 3 for frequencies of 615 and 930 MHz. As can be seen from this figure, an error of approximately one-half inch in spacing the antennas one meter apart can change the coupling data by 15 dB. Obviously, data with such large coupling variations as a function of both frequency and separation distance are of little value, and the possibility of correlating such data with data obtained in an open-field test area is small.

4.4.2.4 Hooded Antenna

Several measurement techniques for reducing the coupling variations in shielded enclosures have been investigated on previous research programs [23]-[25]. A hooded antenna measurement approach which reduces the coupling errors to a level comparable to those normally encountered in open-field measurements has been developed for the 200 MHz to 10 GHz frequency range [21], [22]. For frequencies sufficiently high that "ray theory" can be applied, the hooded antenna measurement concept is illustrated in Figure 4. A number of possible signal paths are shown in the shielded enclosure; but as illustrated, only that signal traveling the direct path reaches the probe antenna. The antenna hood consists of a metal shield or box, open on one end, with walls which are lined on the inside with absorbing material. Also, the wall opposite the open end of the hood is lined with absorbing material to prevent reflections from this wall to the probe antenna. The absorber-lined walls of the hood, together with the one lined wall of the enclosure, approximate for the probe antenna the six absorber-lined walls of an anechoic chamber; however, the hooded antenna technique requires significantly less absorbing material.

Early experimental investigations of the hooded antenna concept indicated that this technique was capable of reducing the coupling variations in shielded enclosures to a level comparable with the variations normally encountered in open field measurements. For example, radiation patterns of an 18-inch dish antenna with a log-periodic feed at a frequency of 2 GHz are shown in Figure 5. These patterns were made in both open-field and shielded enclosure test areas, and with the probe antenna both unhooded and hooded. As

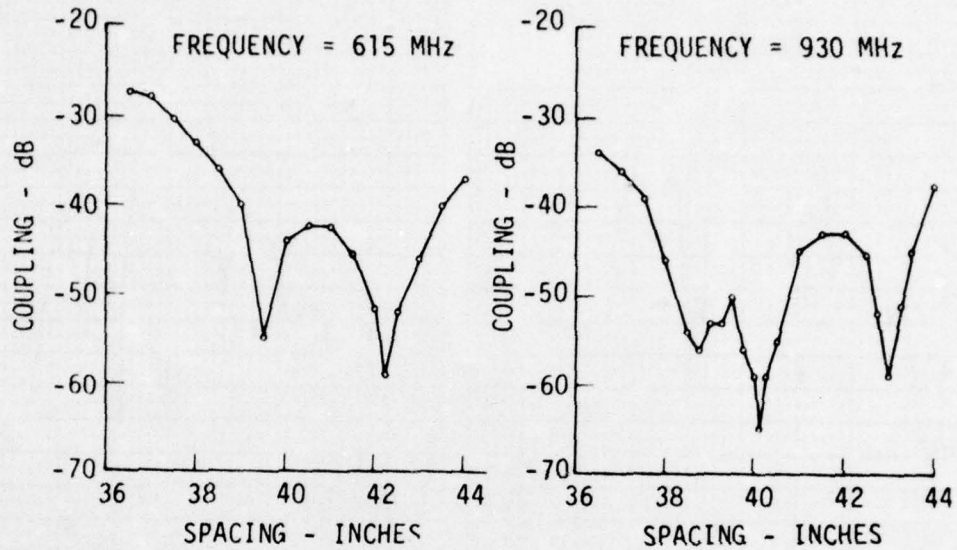

Figure 3. Coupling Between Antennas in a Shielded Enclosure as a Function of Spacing.

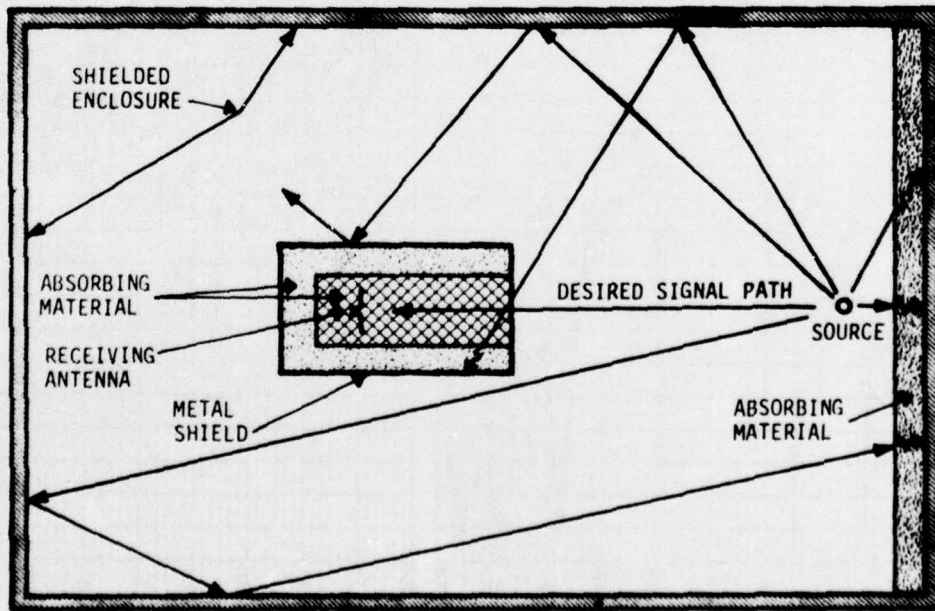

Figure 4. Diagram of a Hooded Antenna Measurement Setup in a Shielded Enclosure.

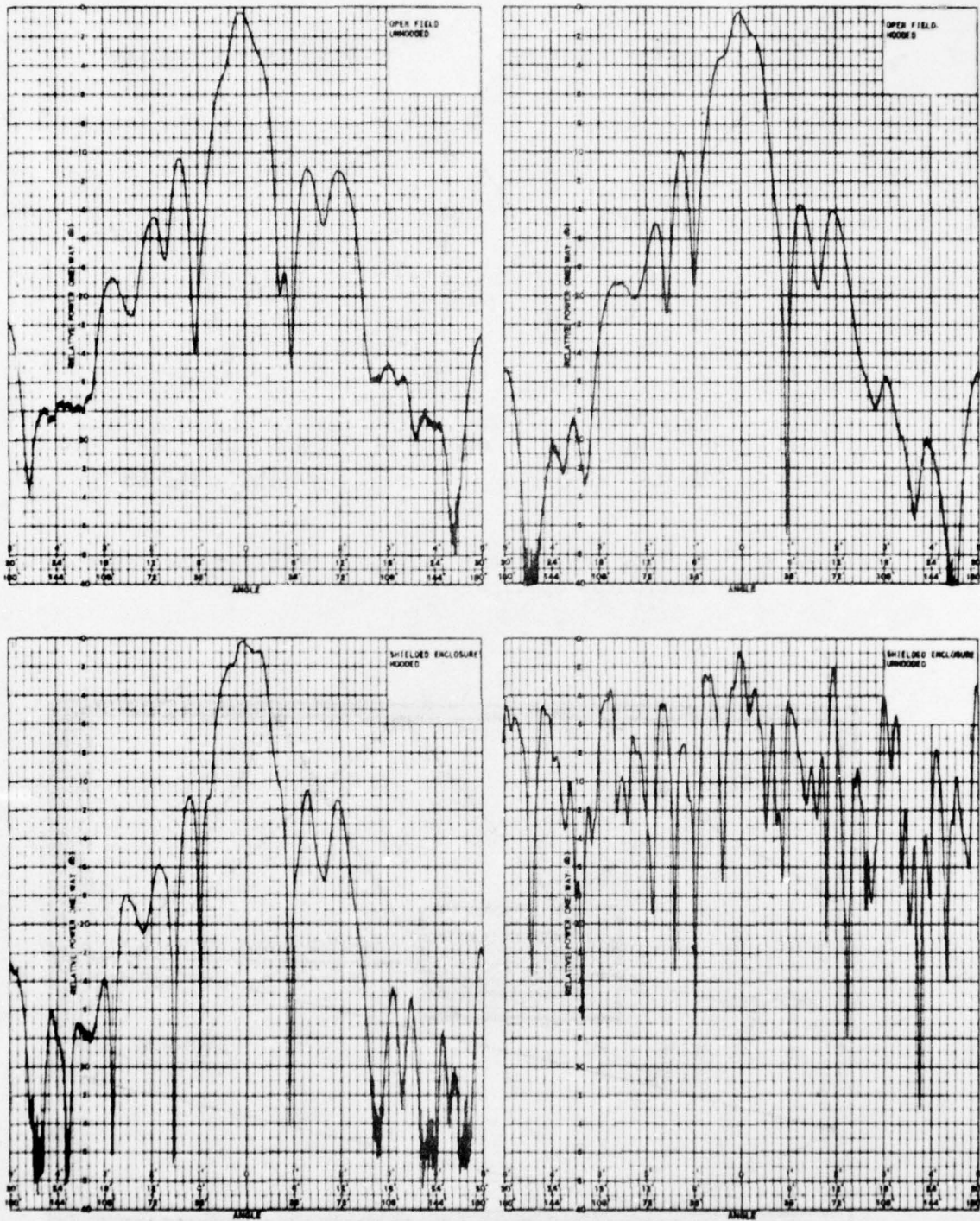

Figure 5. Antenna Patterns of an Eighteen Inch Dish with a Log-Periodic Feed at a Frequency of 2 GHz.

can be seen, there is good correlation between the two open field patterns and the pattern made in the shielded enclosure with the hooded probe antenna. However, severe distortion is apparent in the pattern made in the shielded enclosure with the unhooded probe antenna.

The development of the hooded antenna concept was based on the hypothesis that the absorber-lined hood produces a secondary field pattern that closely approximates the field that would be obtained from a plane wave radiating through a circular aperture in an infinite absorbing screen. That is, the pattern of the hood is essentially the diffracted field that would result from the aperture of the hood. The normalized field pattern of a uniformly illuminated circular aperture* in a perfectly absorbing screen of infinite extent is given by

$$F = (1 + \cos\theta) \frac{J_1\left(\frac{\pi A}{\lambda} \sin\theta\right)}{\frac{\pi A}{\lambda} \sin\theta}, \quad (1)$$

where

A = aperture diameter,

λ = free-space wavelength,

θ = angle with respect to the aperture normal, and

J_1 = first order Bessel function.

The patterns calculated from this equation were compared to the measured patterns obtained with the original hoods [22]. The correlation was sufficient to demonstrate that the pattern of the hooded antenna was determined primarily by the aperture of the hood. Thus, it was concluded that the hooded antenna can be designed to provide beamwidth and sidelobe characteristics on the basis of aperture calculations; therefore, the pattern characteristics of a given hooded antenna configuration can be accurately predicted over a frequency range of interest.

*See S. Silver, Microwave Theory and Design, McMill Book Company, 1949, pp. 169-199; E. C. Jordan, Electromagnetic Waves and Radiating Systems, Prentice-Hall, Inc., 1950, pp. 568-579; and J. D. Kraus, Antennas, McGraw-Hill Book Company, pp. 343-346.

Originally, two hooded antennas were designed, constructed, and evaluated. The first antenna for the 200 to 1500 MHz frequency range is illustrated in Figure 6 while the 1 to 12 GHz hooded antenna is shown in Figure 7. Numerous measurements were conducted to determine the characteristics of these hooded antennas. For example, gain, VSWR, field patterns, and polarization patterns were determined as functions of frequency. Also, the 200 to 1500 MHz hooded antenna was used to measure actual case emissions in both the open field and in an 8 x 8 x 20 foot shielded enclosure.

To further demonstrate the ability of the hooded antenna technique to reduce the ± 40 dB measurement errors in shielded enclosures, the coupling between two antennas was measured for a one meter spacing in an 8 x 8 x 20 foot shielded enclosure over the 1 MHz to 10 GHz frequency range [22]. Conventional dipole antennas were used as receiving antennas over the range from 1 to 200 MHz, and hooded receiving antennas were used over the 200 MHz to 10 GHz range. Results of these radiated measurements are shown in Figure 8. Again, the shielded enclosure curve has been normalized with respect to a corresponding coupling curve obtained in the open field. The figure shows that radiation levels measured in the enclosure over the 1 to 30 MHz frequency range are approximately 2 to 3 dB lower than the open field results. In the 30 to 200 MHz range, the figure indicates that radiation levels deviate as much as ± 40 dB from the open field results; however, when the hooded antenna approach was used from 200 MHz to 10 GHz, it is seen that the radiation levels were within 2 to 3 dB, not ± 40 dB, of the open field levels.

Based on the investigations and tests summarized above, it was concluded that reliable radiated measurements, which can be correlated with open field measurements, can be made with unhooded probe antennas in conventional 8 x 8 x 20 foot shielded enclosures over the 1 to 30 MHz frequency range. The corresponding frequency range for other size enclosures may be established by scaling the results for the 8 x 8 x 20 foot enclosure. Furthermore, these evaluations indicated that, with only two hooded antennas, reliable radiated measurements can be made in shielded enclosures over the 200 MHz to 12 GHz frequency range.

Both of the original hooded antennas employed a balanced conical log-helix design. This design was chosen after considerable evaluation of

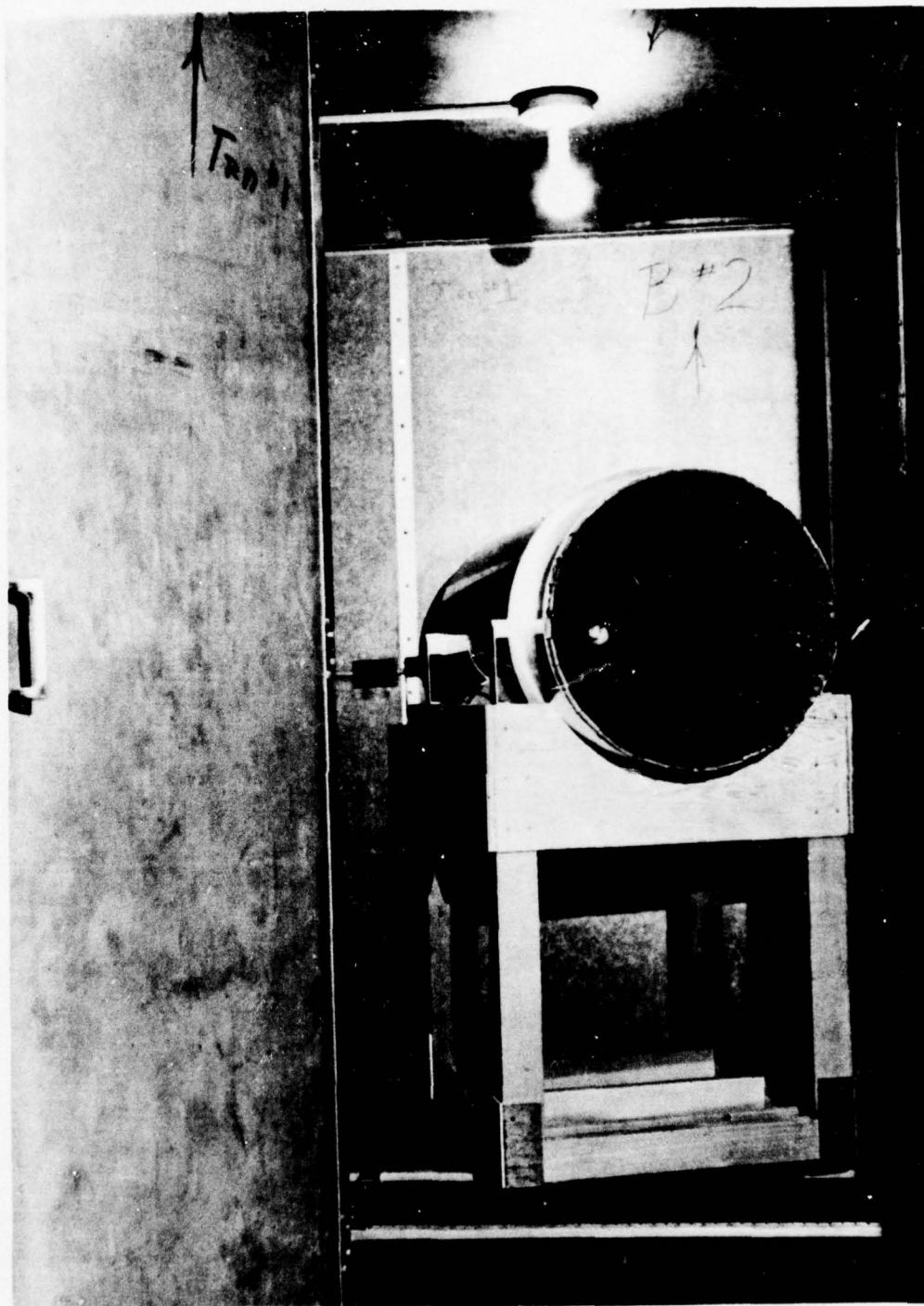

Figure 6. UHF Hooded Antenna.

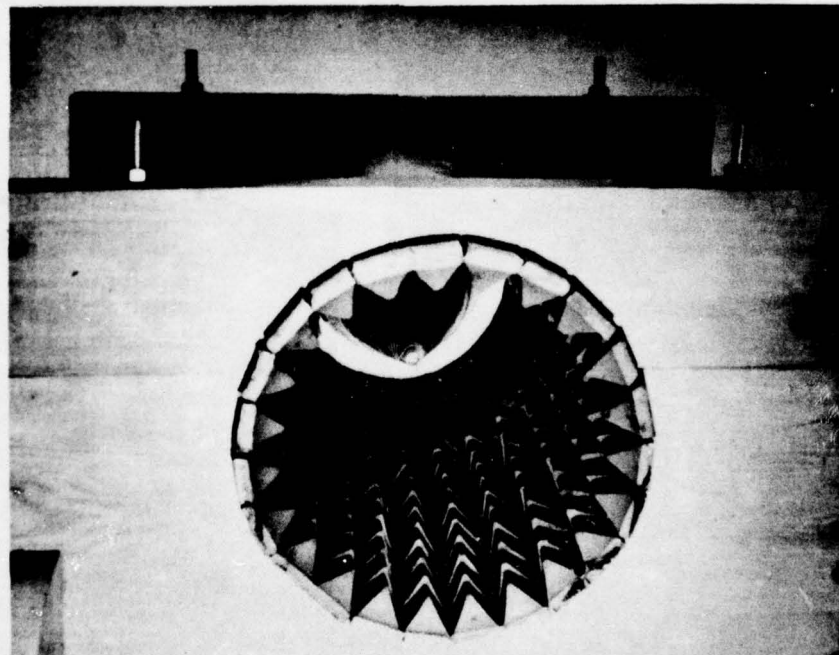
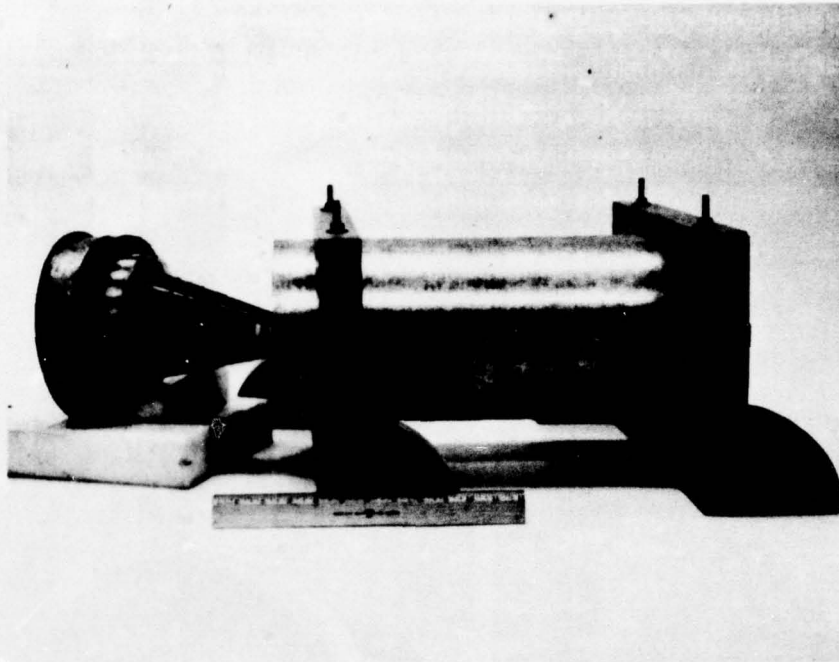

Figure 7. Two Views of Microwave Hooded Antenna.

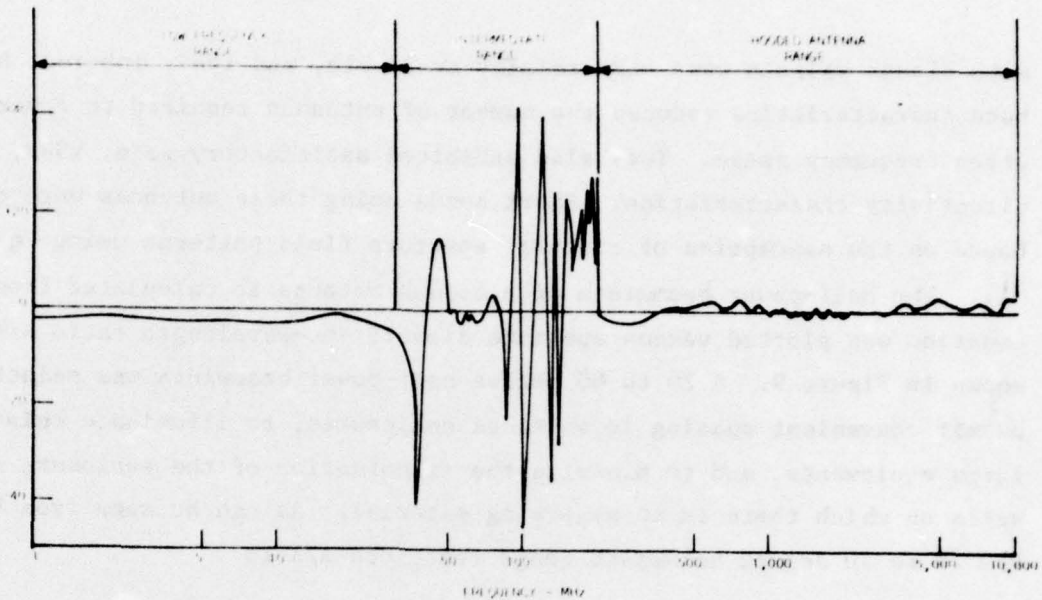

Figure 8. Coupling Between Antennas at 1 Meter Separation, Normalized to Open Field Coupling, over the Frequency Range 1 MHz to 10 GHz.

several broadband, circularly-polarized, balanced antenna configurations [24], [26], [27]. A broad bandwidth was desirable so that a minimum number of antennas was required to cover the entire frequency range. The antenna should have circular polarization so that it would be equally responsive to all linearly polarized signals. Also, the antennas should be balanced to eliminate the effects of signal pickup on the transmission cable. The balanced conical log-helix design was found to be the antenna type that most nearly satisfied all of these requirements. However, the axial length of conical log-helix antennas for operation at frequencies down to 200 MHz required the hood to be four feet long and two feet in diameter. The combined weight of this hood and the absorbing material inside the hood was approximately 350 lbs. This weight along with the large size caused the hood with a balanced conical log-helix antenna to be bulky, difficult to move, and costly.

As an extension of the above research efforts, short hoods with cavity-backed planar spiral antennas were developed to reduce the hood length and, hence, minimize the size, weight, and expense [28]. Cavity-backed antennas

with planar spirals were commercially available, and their inherent broadband characteristics reduced the number of antennas required to cover a given frequency range. They also exhibited satisfactory gain, VSWR, and directivity characteristics. Short hoods using these antennas were designed based on the assumption of circular aperture field patterns using Equation (1). The half-power beamwidth of a hooded antenna as calculated from this equation was plotted versus aperture diameter-to-wavelength ratio A/λ as shown in Figure 9. A 20 to 60 degree half-power beamwidth was selected to permit convenient spacing in shielded enclosures, to illuminate relatively large equipments, and to minimize the illumination of the enclosure side walls on which there is no absorbing material. As can be seen from Figure 9, the 20 to 60 degree beamwidth range restricts A/λ to

$$1 \leq \frac{A}{\lambda} \leq 3 \quad , \quad (2)$$

where

A = aperture diameter and

λ = wavelength.

Furthermore, it was hypothesized that since these aperture diameter and beamwidth considerations are based on a planar wavefront existing at the hood aperture, the distance (ℓ) from the feed antenna to the aperture of the hood must satisfy the condition

$$\ell \geq \frac{2A^2}{\lambda} \quad . \quad (3)$$

This restriction on ℓ should maintain uniform illumination over the aperture to within a maximum phase error of $\lambda/16$ (22.5 degrees). If A/λ were 3 as permitted by Equation (2), then the above equation requires that the hood length be greater than six times the diameter of the hood, i.e., $\ell \geq 6A$. Because of the importance of a short hood length (to minimize hood weight, size, and cost), it was decided that the short hood design should not be based entirely on theoretical equations. Instead, a laboratory model of a short hood should be constructed and evaluated prior to finalizing the design. To this end, three adjustable-length hooded antennas, one of which is illustrated in Figure 10, were constructed for evaluation [29]. Antenna

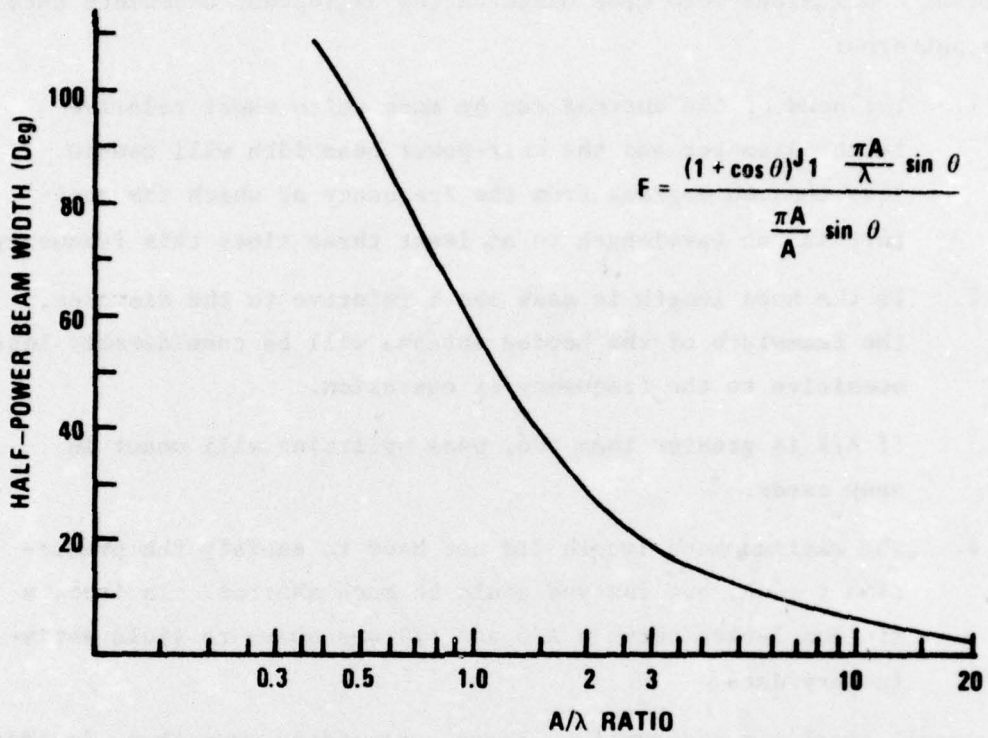

Figure 9. Theoretical Beam Width of Hooded Antenna vs Aperture Size.

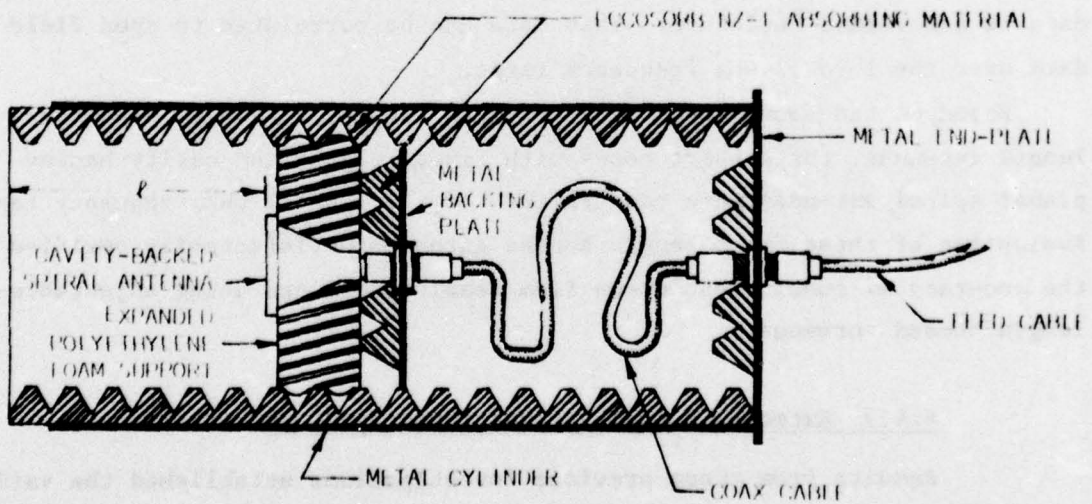

Figure 10. Diagram of Adjustable-Length Hooded Antenna.

patterns were plotted for various values of l at several frequencies. Four important conclusions were made based on the half-power beamwidth data from these patterns:

1. The hood of the antenna can be made quite short relative to the diameter and the half-power beamwidth will remain less than 60 degrees from the frequency at which the aperture is one wavelength to at least three times this frequency.
2. If the hood length is made short relative to the diameter, the beamwidth of the hooded antenna will be considerably less sensitive to the frequency of operation.
3. If A/λ is greater than two, beam splitting will occur in many cases.
4. The minimum hood length did not have to satisfy the prediction $l \geq 6A$, but instead could be much shorter. In fact, a minimum length between $A/3$ and $A/2$ was shown to yield satisfactory data.

The overall conclusions drawn from these evaluations were that, in addition to being smaller, lighter, and less expensive, short hooded antennas yield a more constant beamwidth as a function of frequency than the long hood, and short hoods with cavity-backed spiral antennas provide reliable measurement data in a shielded enclosure. This data can be correlated to open field data over the 1 to 12 GHz frequency range.

Based on the above conclusions from the investigation of adjustable-length antennas, three short hoods with fixed lengths and cavity-backed planar spiral antennas were constructed for the 1 to 12 GHz frequency range. Evaluation of these fixed length hooded antennas satisfactorily verified the accuracy of conclusions drawn from results obtained using adjustable-length hooded antennas.

4.4.3 Extended Hooded Antenna Investigations

Results from these previous investigations established the validity of the hooded antenna concept and provided valuable direction for this program. Based on these results, it was decided that short hoods with cavity-backed

spiral antennas should be recommended for FAA use to assure reliable data over the 1 to 10 GHz frequency range. Also, the hooded antenna concept should be extended to frequencies below 1 GHz. A major objective of this program, therefore, was the design, construction, and evaluation of hooded antennas for radiated testing at frequencies below 1 GHz. The three primary goals of this effort were to minimize the hood length, achieve as low an operating frequency as possible, and obtain accurate, repeatable, and reliable radiated data in a shielded enclosure.

The following equations, based on the results of the previous programs, were used to design the short hood for frequencies below 1 GHz:

$$1 \leq \frac{A}{\lambda} \leq 2, \text{ and} \quad (4)$$

$$\frac{A}{3} \leq \ell_{\min} \leq \frac{A}{2}, \quad (5)$$

where

A = aperture diameter

ℓ = hood length from antenna to aperture, and

λ = wavelength.

For the initial approach, the upper frequency limit of 1 GHz was used as the starting point. This yielded a minimum wavelength of 11.8 inches; and since A/λ must be less than or equal to two, the aperture diameter became

$$\begin{aligned} A &= 2\lambda_{\min} & (6) \\ &= 23.6 \text{ inches.} \end{aligned}$$

Similarly, since A/λ must be greater than or equal to 1, the maximum wavelength is

$$\begin{aligned} \lambda_{\max} &= A & (7) \\ &= 23.6 \text{ inches.} \end{aligned}$$

This predicted a minimum operating frequency of approximately 500 MHz; further, the minimum value of ℓ as calculated from Equations (5) and (6) was 7.9 inches.

4.4.3.1 Adjustable Length Hooded Antenna

Since definition of a minimum hood length on a before-the-fact basis had been difficult on previous programs, it was felt that this effort should include preliminary measurements using an adjustable-length hood. The 200 to 1500 MHz hood constructed on a previous program and shown in Figure 6 formed the basic adjustable-length structure. This hood is a metal cylinder lined with Eccosorb Type NZ-1 Absorbing Material. The outside diameter is 24 inches, the inside diameter is 22-1/4 inches, and the overall length is 48 inches. The diameter of the expanded polyethylene foam support was made to be a tight sliding fit to the inside of the hood and, hence, was capable of supporting the cavity-backed spiral antenna at any location along the hood length. This configuration made it possible to vary the distance l between the hood aperture and the cavity-backed spiral antenna from zero to 22 inches. Originally, an available AEL Model ASN 117A cavity-backed antenna with a planar spiral and a specified operating frequency range of 400 MHz to 4 GHz was used as the feed antenna for the adjustable hood; however, tests indicated that its main beam was skewed approximately 10 degrees off boresight. Therefore, it could not be used for these investigations because it would not uniformly illuminate the hood aperture. Consequently, a less desirable (because of its reduced frequency range) AEL Model ASN 113A antenna, which had a specified operating frequency range of 700 MHz to 2.8 GHz, had to be employed as the feed antenna for the hood.

Far-field radiation patterns of the unhooded Model ASN 113A cavity-backed antenna with a planar spiral were plotted over the 200 to 1000 MHz frequency range by rotating the antenna in the field produced by a tuned horizontal dipole. Figures 11 and 12 show the patterns for this unhooded antenna. Although the specified frequency range for this antenna was 700 MHz to 2.8 GHz, Figures 11 and 12 indicated that it was usable down to at least 400 MHz in hooded antenna evaluations.

Antenna patterns of the adjustable-length hooded antenna employing the Model ASN 113A antenna as a feed were made in an anechoic chamber at six frequencies--1 GHz ($A = 1.88\lambda$), 800 MHz ($A = 1.51\lambda$), 600 MHz ($A = 1.13\lambda$), 500 MHz ($A = 0.94\lambda$), 450 MHz ($A = 0.85\lambda$), and 400 MHz ($A = 0.75\lambda$)--and for eleven values of l ranging from 1-1/2 to 22 inches. These patterns were

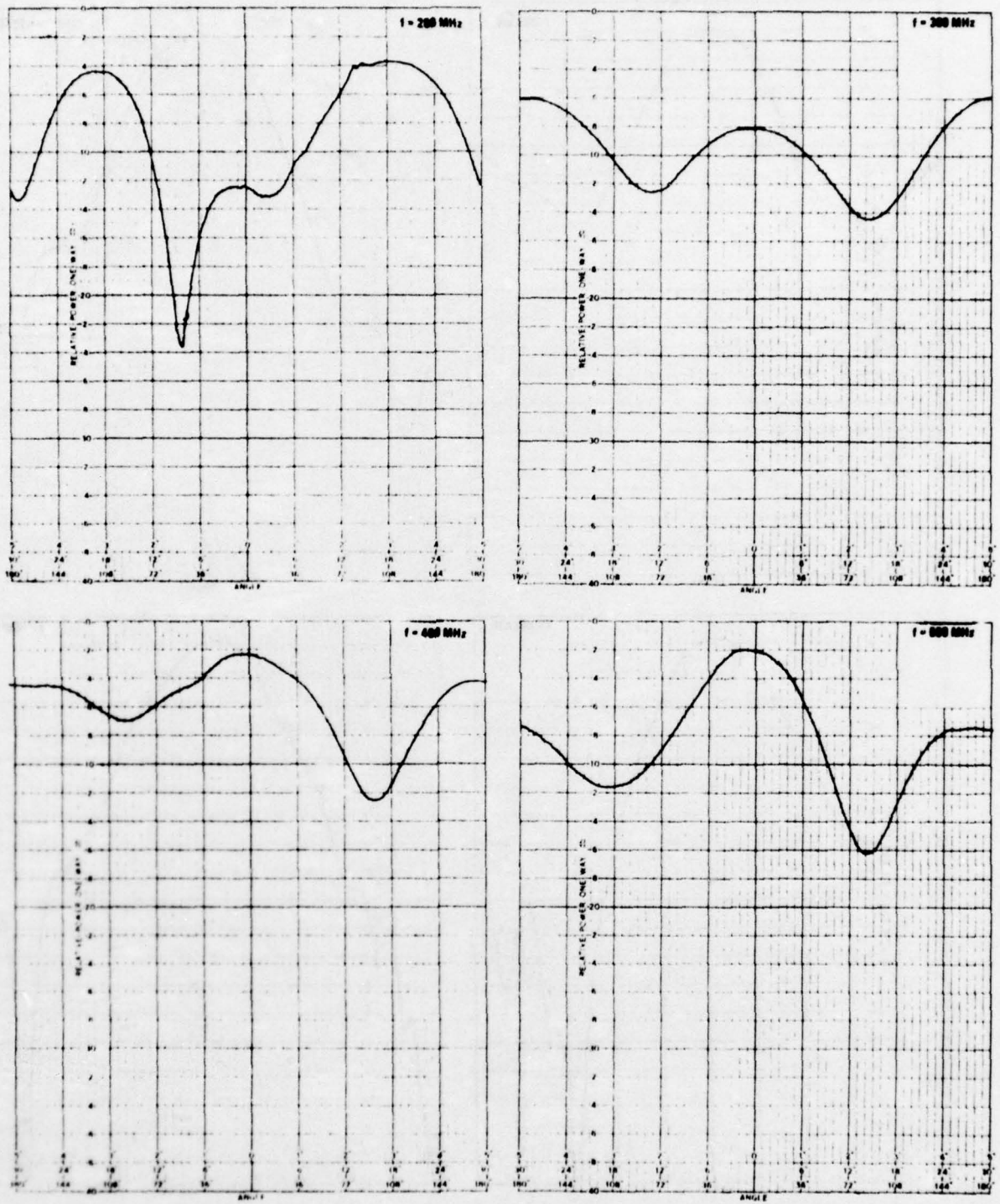

Figure 11. Patterns for Unhooded Antenna, 200-500 MHz.

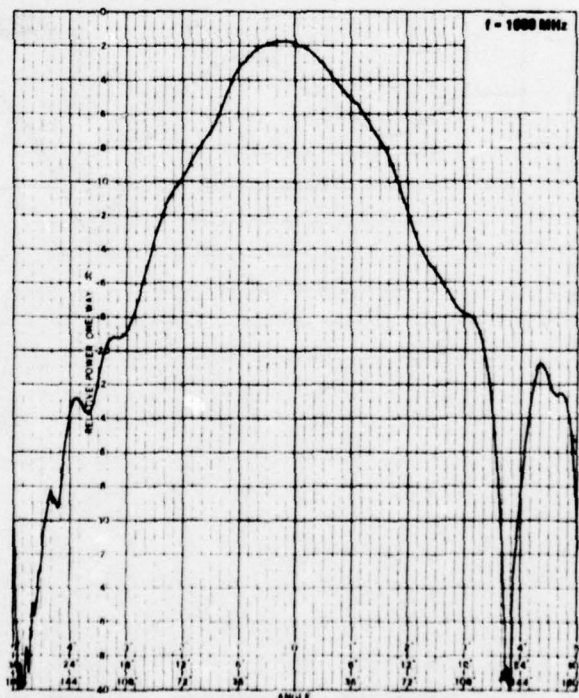
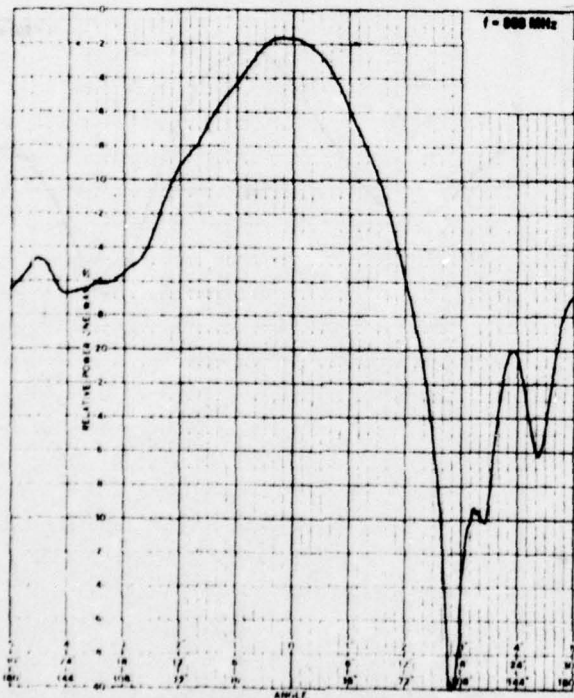
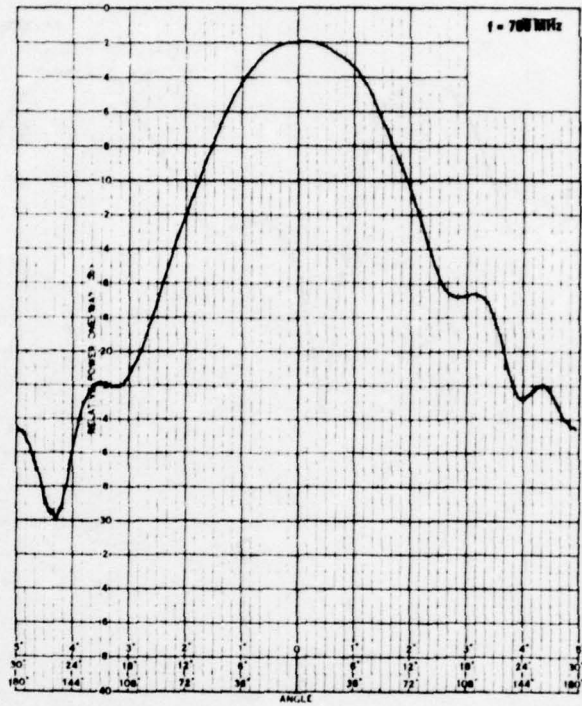
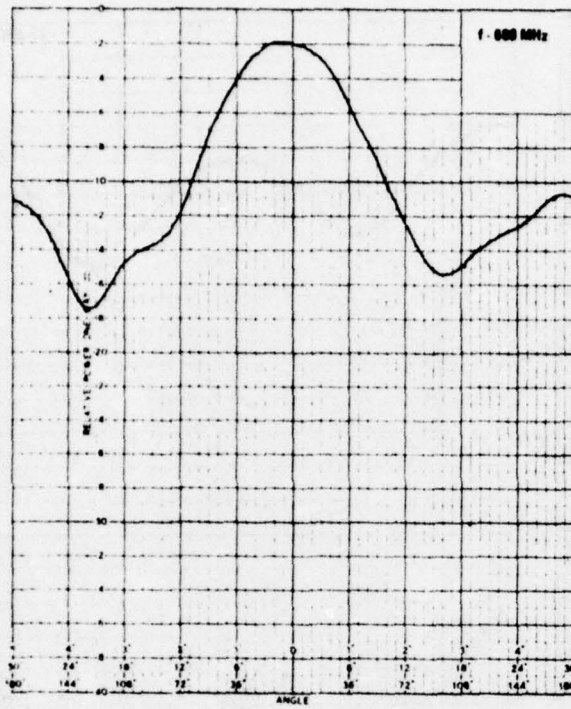

Figure 12. Patterns for Unhooded Antenna, 600-1000 MHz.

made by rotating the hooded antenna in the field produced by a tuned horizontal dipole spaced approximately 9 feet from the hood aperture to insure far-field conditions ($2A^2/\lambda = 7$ feet at 1000 MHz). Typical patterns obtained for ℓ values of 1-1/2, 4, 8, and 22 inches at 400, 600, 800, and 1000 MHz are shown in Figures 13, 14, 15, and 16. Also, the half-power beamwidth data from all of the adjustable-length hooded antenna patterns are plotted in Figure 17. These figures show that, for frequencies below 500 MHz ($A \leq \lambda$), the beamwidth is greater than 60 degrees as predicted by Equation 7, and reducing the hood length at these lower frequencies had no significant effect on the antenna patterns.

For frequencies greater than 500 MHz where the hood aperture is greater than λ , the figures show that reducing the hood length from 22 to 1-1/2 inches results in appreciable effects on the antenna patterns. The amount of variation in the half-power beamwidth as a function of length for each specific frequency increased as the frequency was increased from 500 to 1000 MHz. The largest variation occurred at the highest frequency (1000 MHz) where the beamwidth increased from 22 to 65 degrees. In general, Figure 17 shows that the most significant change for this frequency range was obtained as the hood length was decreased from approximately 8 to 1-1/2 inches.

4.4.3.2 Four Inch Hooded Antenna

Analysis of the patterns and beamwidth curves of the adjustable-length hooded antenna indicated that, if the 60 degree maximum beamwidth constraint were relaxed to approximately 67 degrees, then a hood length of four inches might be adequate. To confirm these initial measurements and to determine the effects of a 67-degree beamwidth on the hooded antenna test configuration, a hooded antenna with a fixed length of approximately four inches was built and evaluated. Figure 18 shows this hooded antenna with actual dimensions of 4-1/8 inches length, 22-1/8 inches inside diameter, and 24 inches outside diameter. The AEL Model ASN 113A cavity-backed spiral was used as the feed antenna and Eccosorb Type NZ-1 Absorbing Material was used to line the inside of the hood.

The measured gain of this short hooded configuration relative to a $\lambda/2$ dipole and the VSWR referred to 50 ohms over the 400 to 1000 MHz frequency range are shown in Figure 19. The top curve shows the gain of the hooded

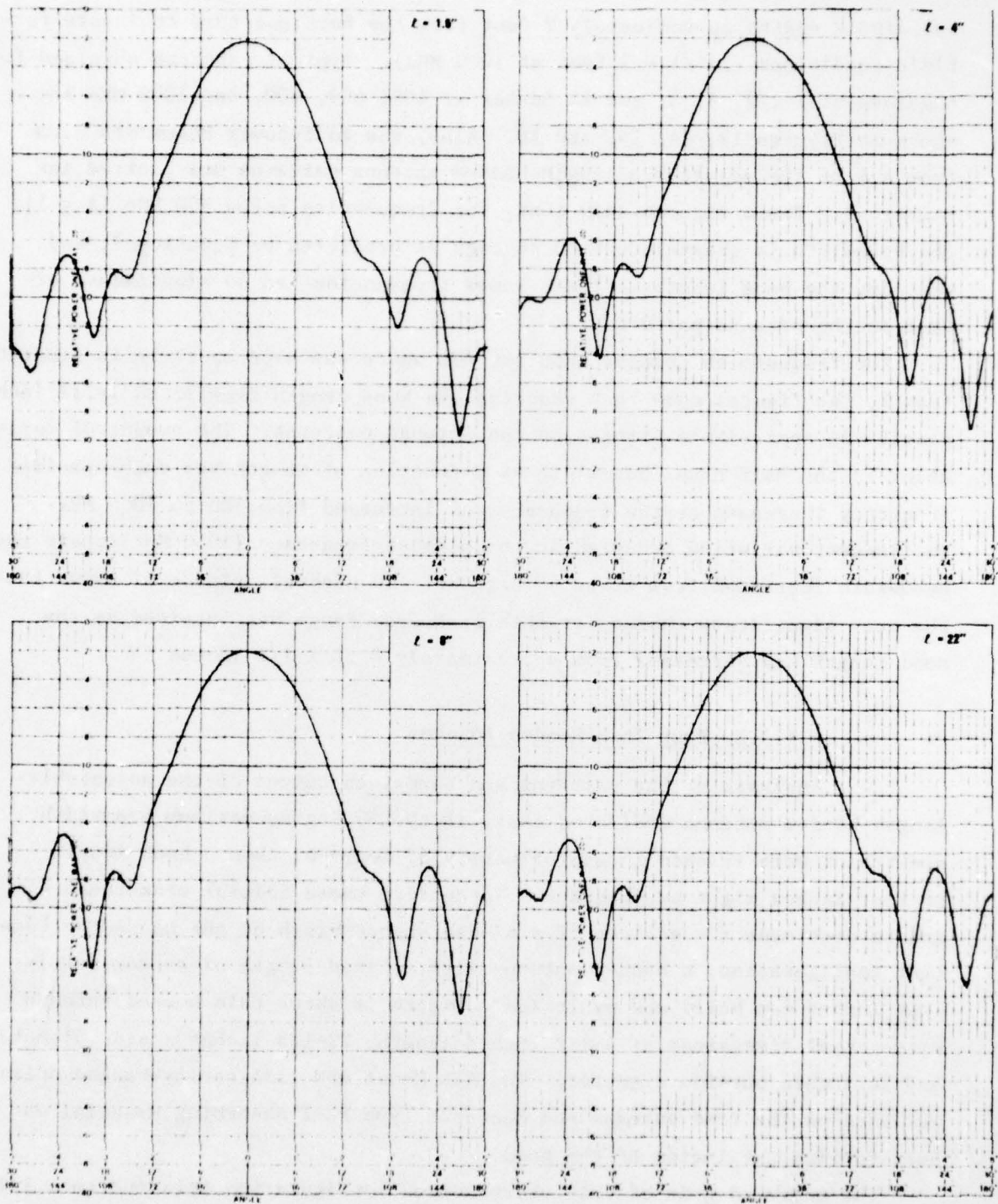

Figure 13. Patterns for Hooded Antenna as a Function of Hood Length, 400 MHz.

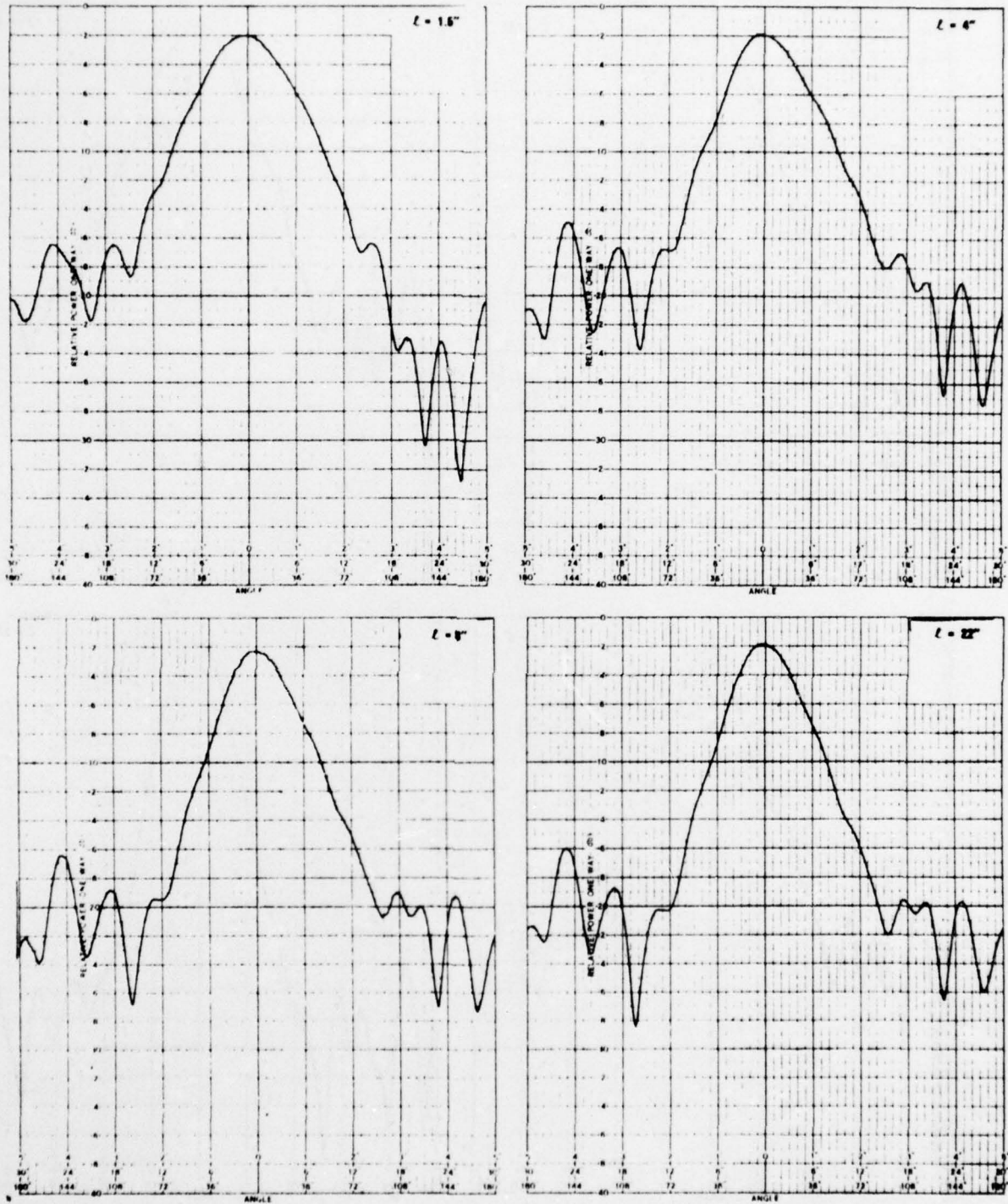

Figure 14. Patterns for Hooded Antenna as a Function of Hood Length, 600 MHz.

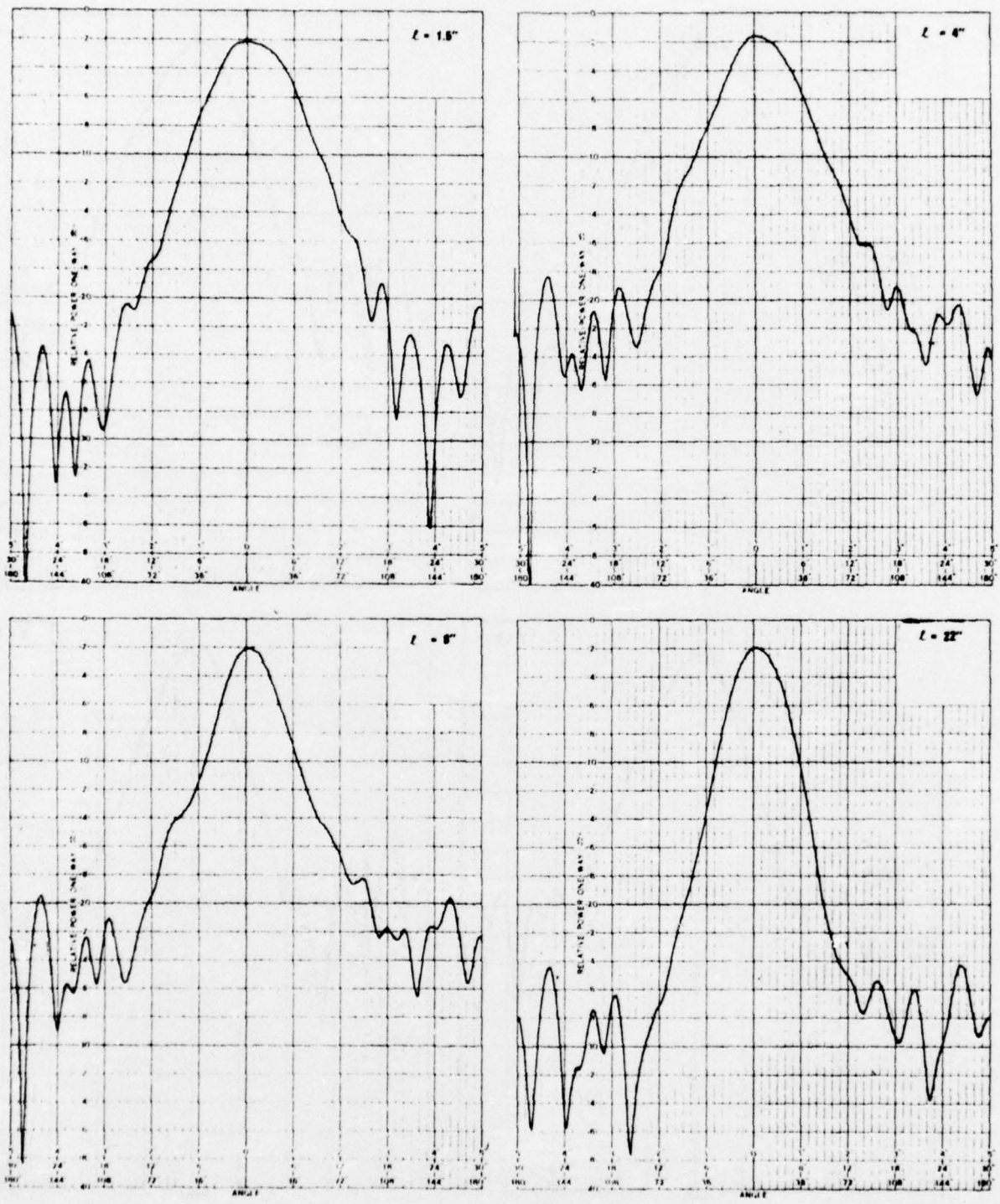

Figure 15. Patterns for Hooded Antenna as a Function of Hood Length, 800 MHz.

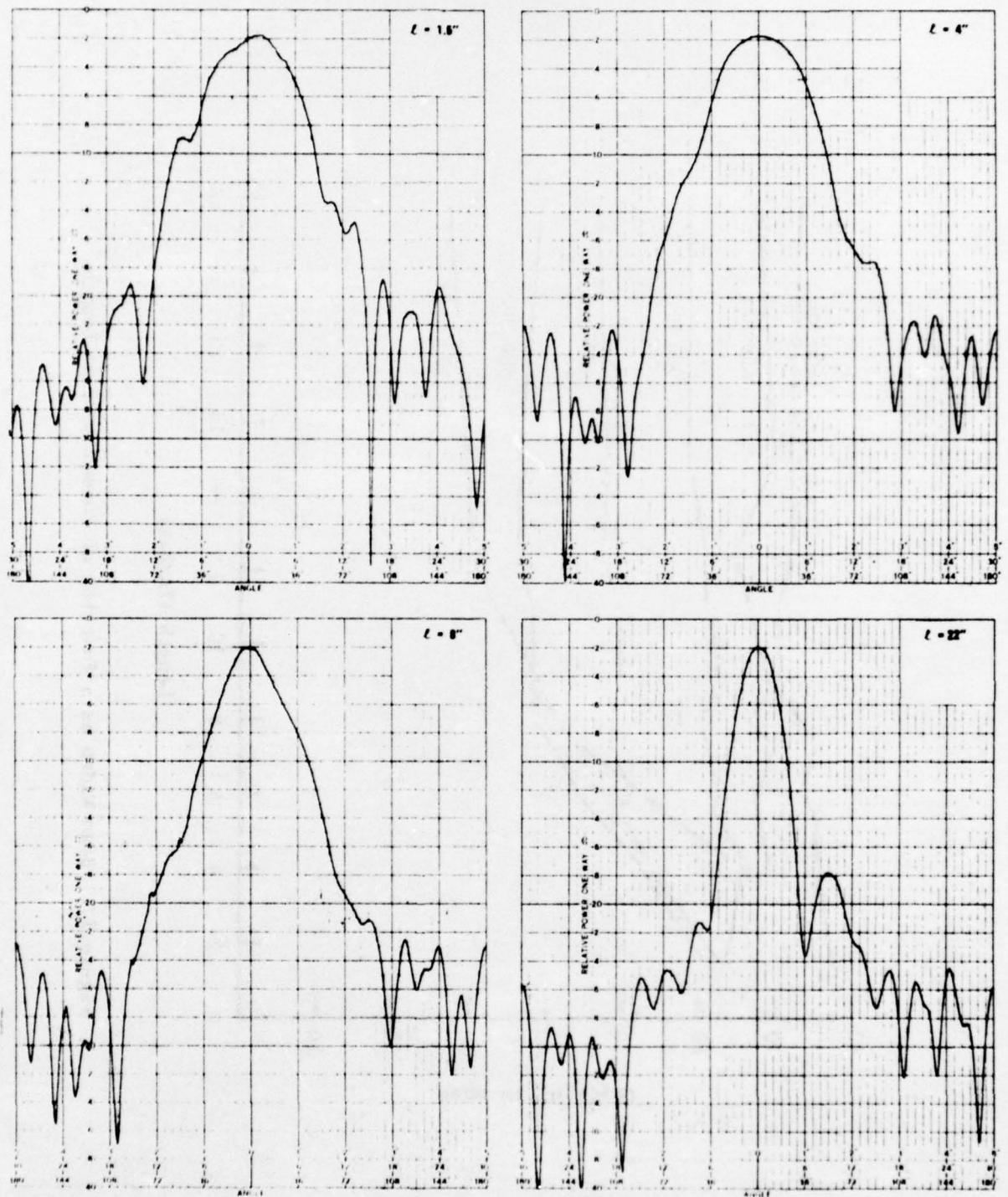

Figure 16. Patterns for Hooded Antenna as a Function of Hood Length, 1000 MHz.

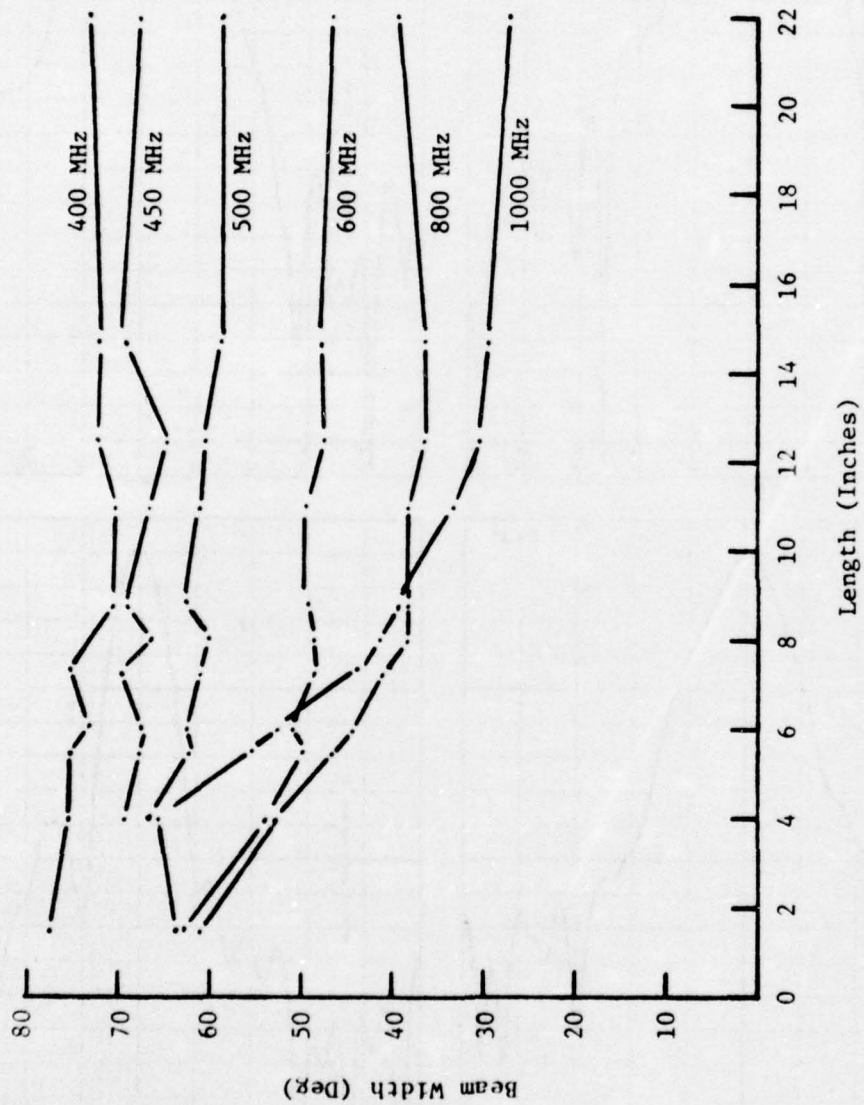

Figure 17. Beam Width as a Function of Hooded Antenna Length.

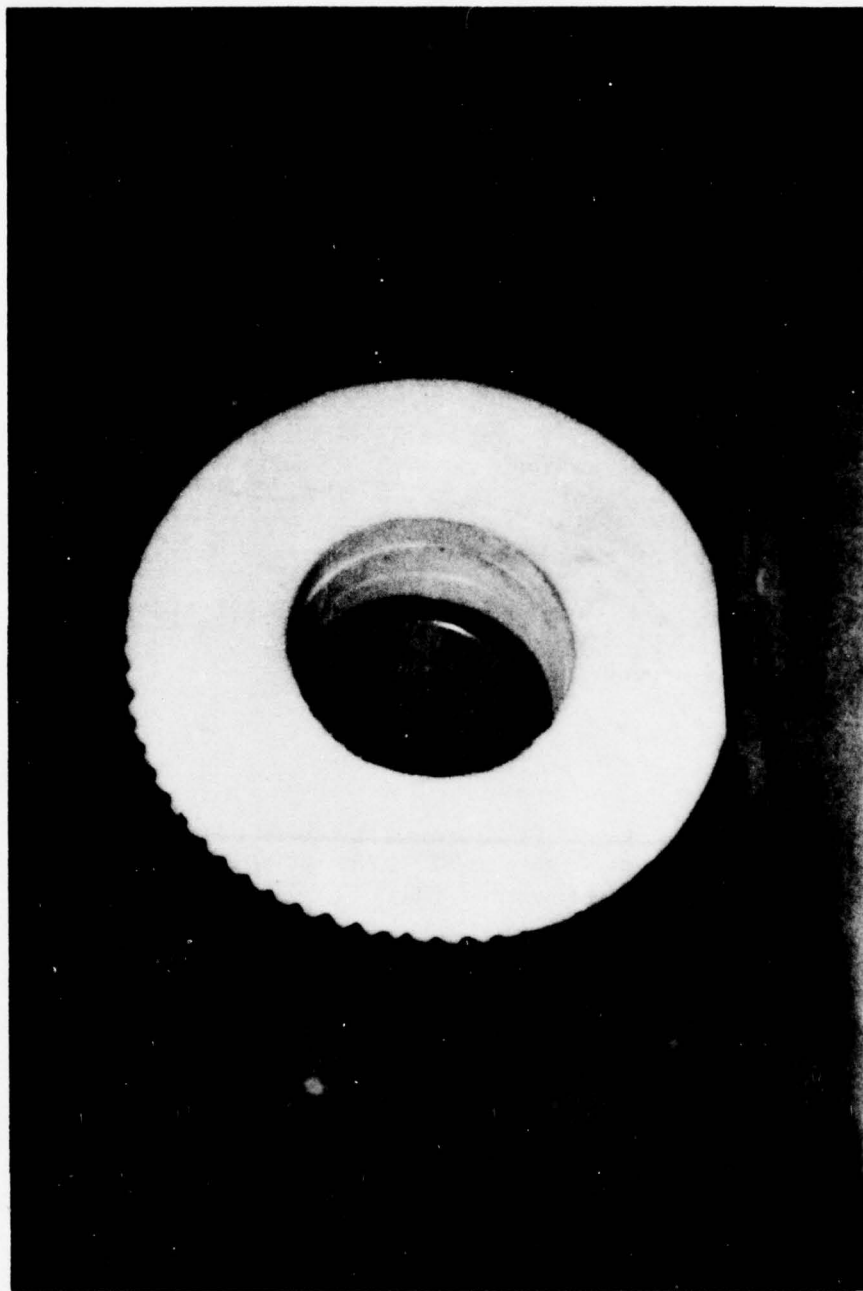

Figure 18. Photograph of 4-1/8 Inch Hooded Antenna.

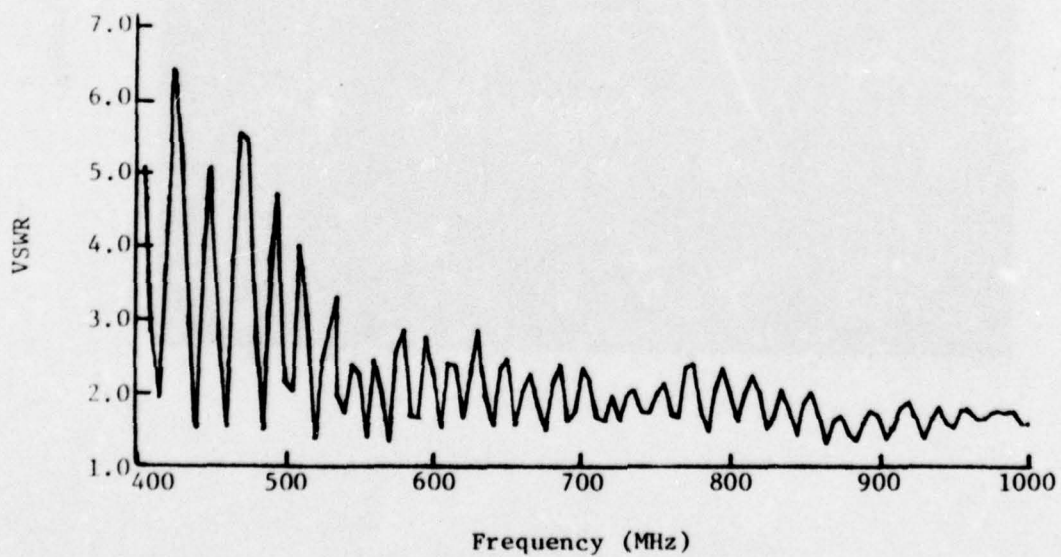
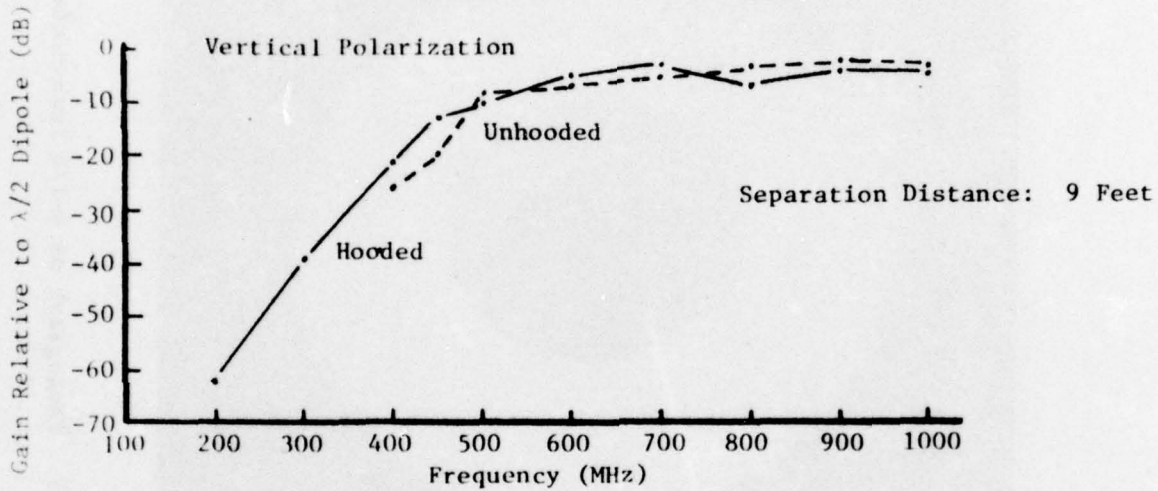
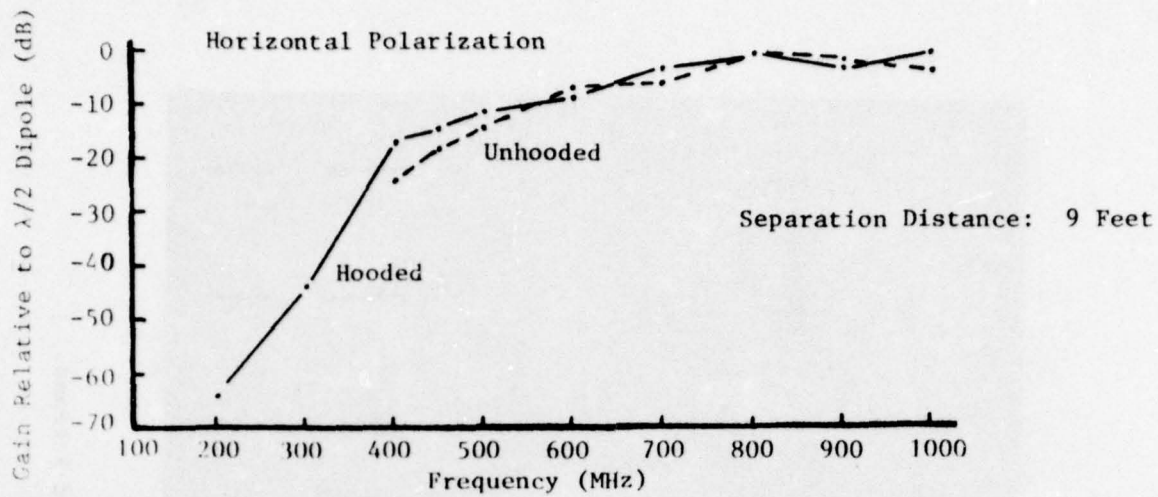

Figure 19. Gain and VSWR Curves For the 4 1/8 Inch Hooded Antenna.

antenna relative to a horizontal dipole radiating source, while the second curve shows the gain relative to a vertical radiating dipole source. The antenna separation distance for both figures was nine feet. The average gain of the 4-1/8 inch hooded antenna relative to a $\lambda/2$ dipole is approximately -10 dB. The gain curves of the AEL Model ASN 113A antenna in a unhooded configuration are also shown for reference. The lower curve shows the average VSWR of this hooded antenna was approximately 2.0.

The far-field radiation patterns for this short hooded antenna were plotted in an anechoic chamber using a tuned horizontal dipole to produce the field. The patterns were made at six different frequencies from 400 to 1000 MHz. Selected patterns over this frequency range are shown in Figure 20. Since the patterns are similar at all frequencies, those shown were selected to show the characteristics in the middle and at either end of the test frequency range. A comparison of these patterns with those in Figures 11 and 12 indicate that the maximum side lobe suppression effects of the hood occurred at the lower frequencies below the design operating frequency range of the unhooded antenna. The half-power beamwidth data taken from all of the hooded and unhooded antenna patterns are presented in Figure 21. For comparison, the half-power beamwidth data for the 4-inch adjustable-length hood is also plotted in Figure 21. These three curves show that, in general, the hood improves (decreases) the antenna beamwidth relative to the unhooded antenna for the entire frequency range. However, this figure also shows that the beamwidth of the 4-1/8 inch hooded antenna was everywhere approximately 10 degrees wider than the beamwidth of the adjustable-length hood with $l = 4$ inches. It was hypothesized that this unexpected increase in beamwidth for the fixed-length hood could be due to the fact that the adjustable-length hood was not designed to have exact dimensions and perfectly fitting elements, but rather to provide a rough, initial estimate of the beamwidths to be expected for various lengths. Thus, it was concluded that these beamwidth data were valid for the 4-1/8 inch fixed-length hood. As such, the beamwidth was too wide since it was greater than 67 degrees at many frequencies and greater than 60 degrees at all frequencies.

Even though the beamwidth of the 4-1/8 inch hood was considered excessive, it was decided that measurements should be made to determine the

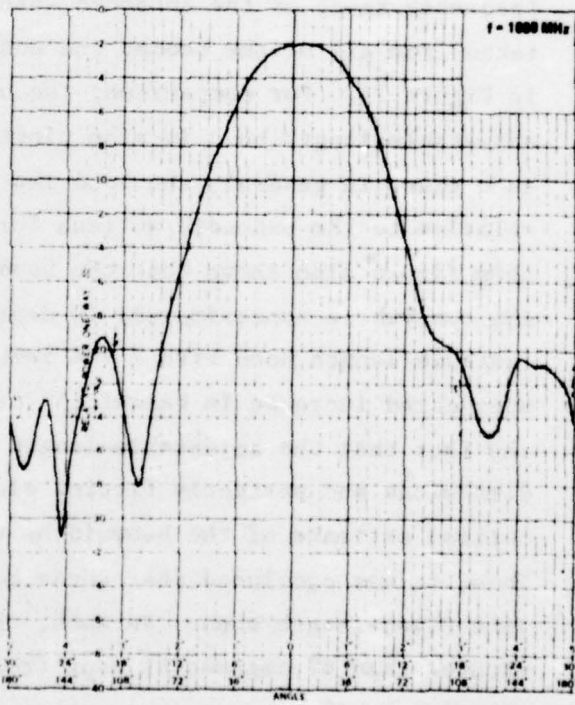
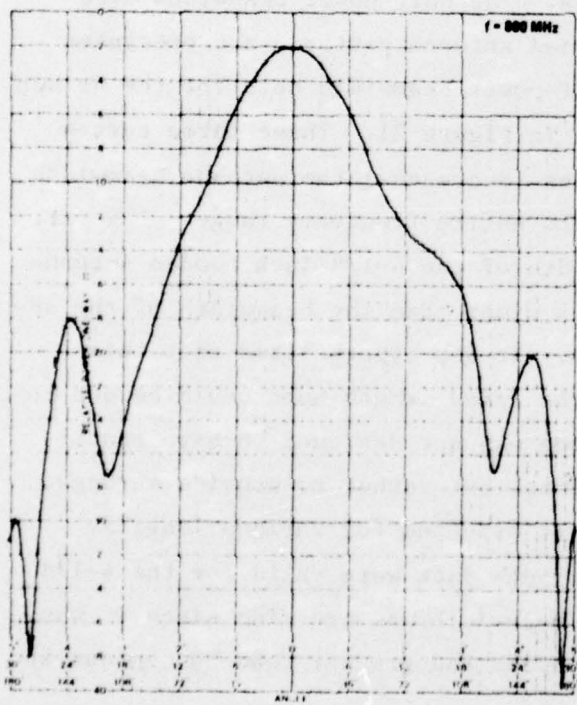
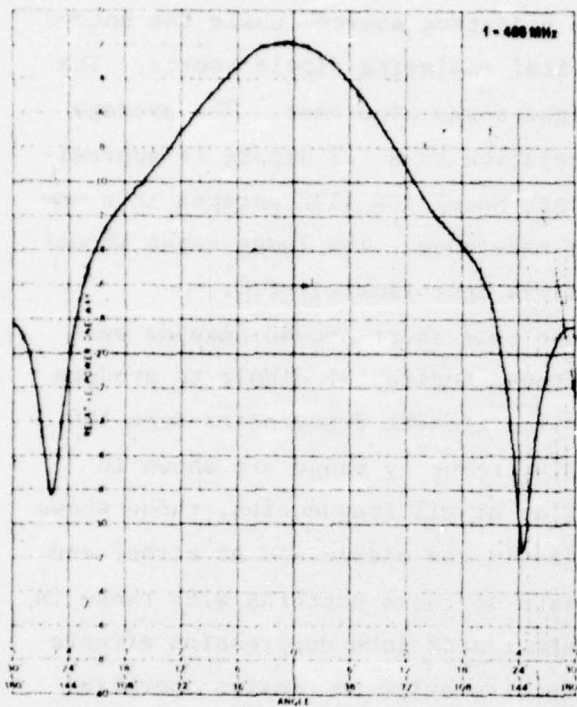

Figure 20. Patterns for 4-1/8 Inch Hooded Antenna, Nine Foot Spacing, 400-1000 MHz.

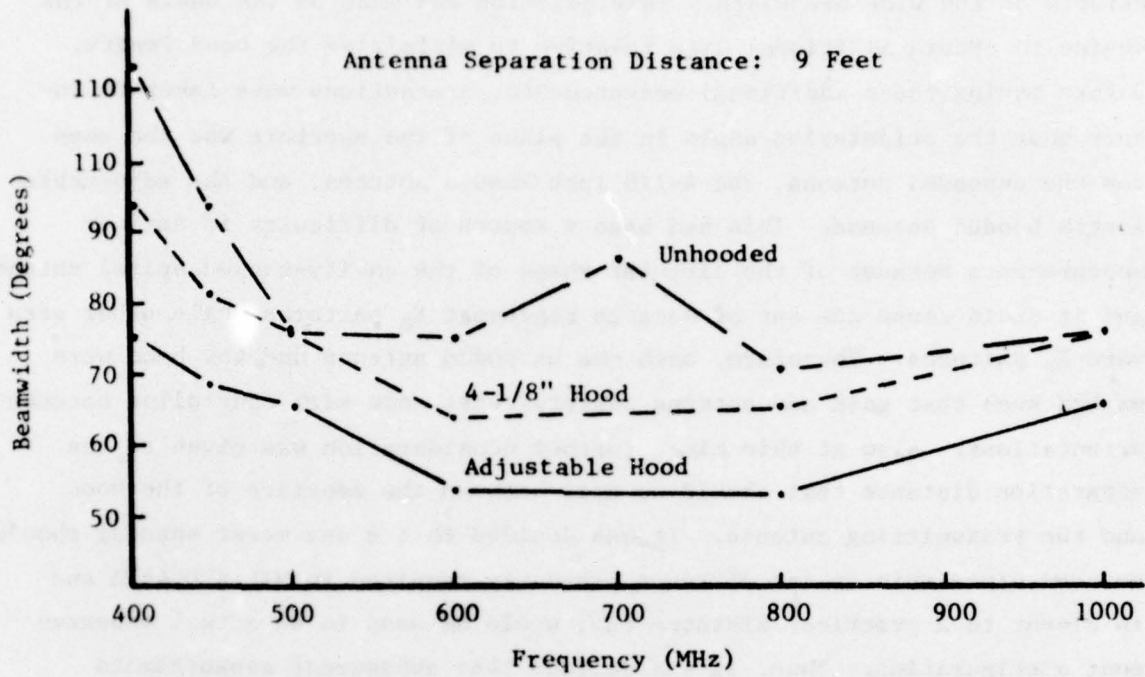

Figure 21. Beamwidth of 4-1/8 Adjustable Length Hooded Antenna.

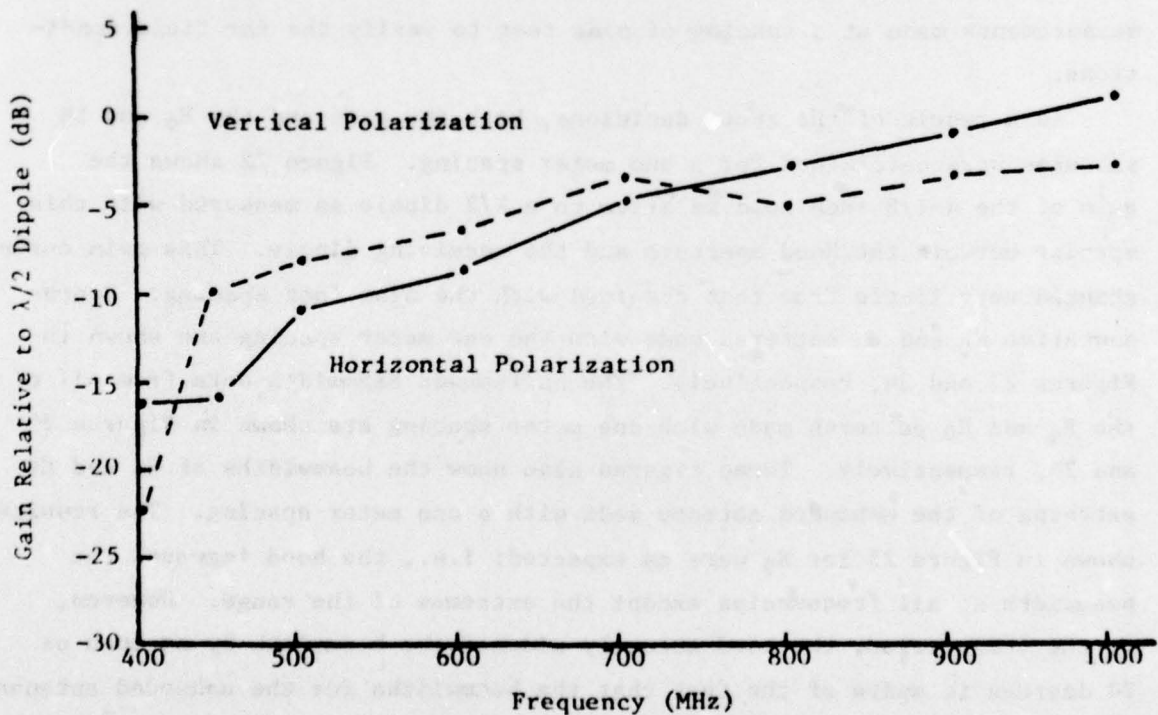

Figure 22. Gain of 4-1/8 Inch Hooded Antenna with Separation Distance of One Meter

effects of the wide beamwidth. This decision was made on the basis of the desire to obtain additional data relative to minimizing the hood length. Before making these additional measurements, precautions were taken to insure that the orientation angle in the plane of the aperture was the same for the unhooded antenna, the 4-1/8 inch hooded antenna, and the adjustable-length hooded antenna. This had been a source of difficulty in earlier measurements because of the circular shape of the cavity-backed spiral antenna, and it could cause one set of data to represent E_ϕ patterns while other sets were E_θ patterns. Therefore, both the unhooded antenna and the hood were marked such that gain and antenna patterns were made with controlled antenna orientations. Also at this time, further consideration was given to the separation distance that should be used between the aperture of the hood and the transmitting antenna. It was decided that a one meter spacing should be used since this is the distance presently required in MIL-STD-461A and is closer to a practical distance that would be used in an actual measurement configuration. Thus, it was decided that subsequent measurements would involve a one meter separation distance, but with a limited number of measurements made at a spacing of nine feet to verify the far field conditions.

As a result of the above decisions, both the gain and the E_ϕ and E_θ patterns were determined for a one meter spacing. Figure 22 shows the gain of the 4-1/8 inch hood relative to a $\lambda/2$ dipole as measured with this spacing between the hood aperture and the receiving dipole. This gain curve changed very little from that obtained with the nine foot spacing. Representative E_ϕ and E_θ patterns made with the one meter spacing are shown in Figures 23 and 24, respectively. The half-power beamwidth data from all of the E_ϕ and E_θ patterns made with one meter spacing are shown in Figures 25 and 26, respectively. These figures also show the beamwidths of E_ϕ and E_θ patterns of the unhooded antenna made with a one meter spacing. The results shown in Figure 25 for E_ϕ were as expected; i.e., the hood improved the beamwidth at all frequencies except the extremes of the range. However, in the θ -direction, the hood actually widened the beamwidth by as much as 24 degrees in spite of the fact that the beamwidths for the unhooded antenna were approximately the same in the ϕ and θ directions. An explanation for this unexpected result was not found during this investigation.

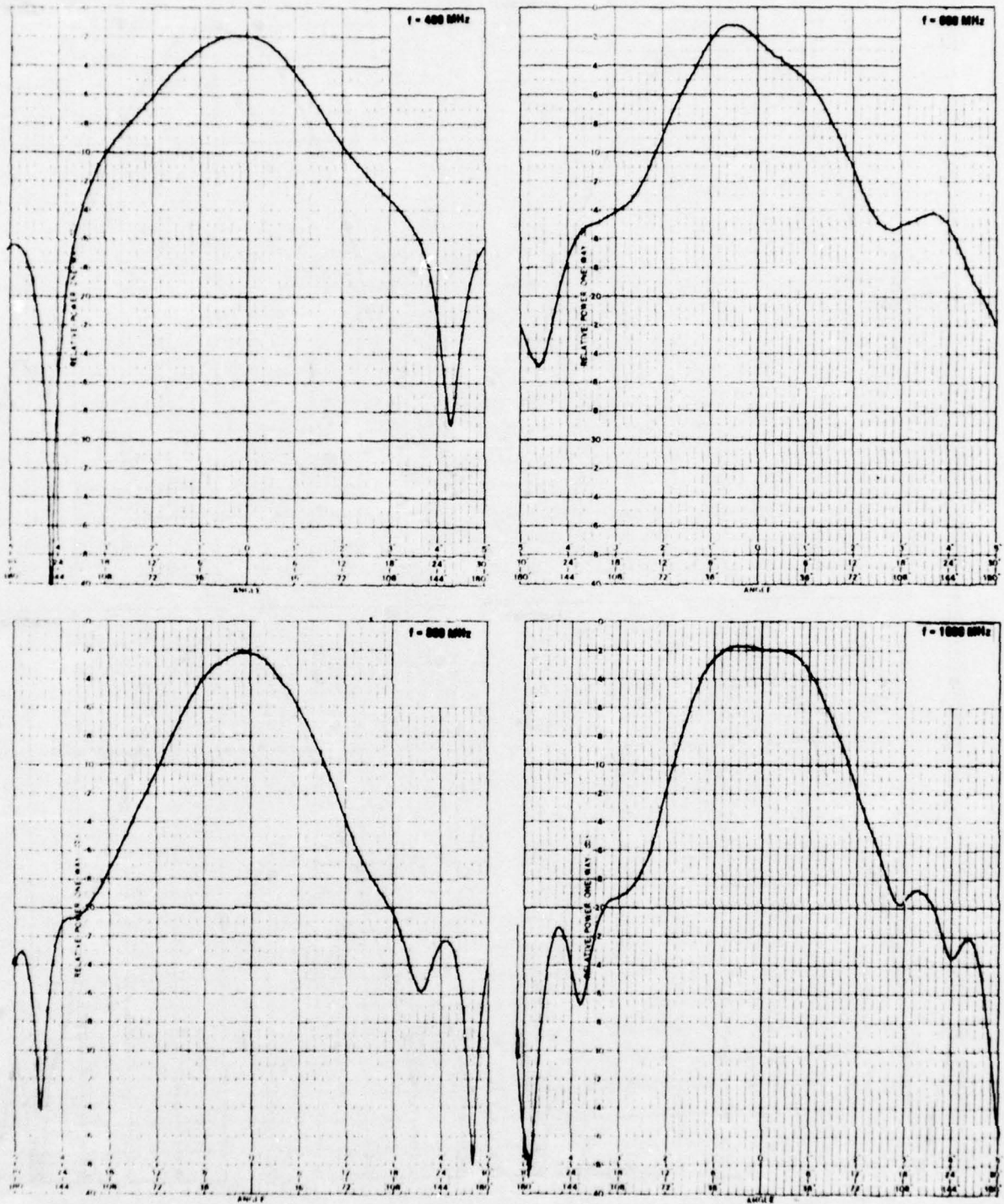

Figure 23. E_{θ} Patterns for 4-1/8 Inch Hooded Antenna, One Meter Spacing, 400-1000 MHz.

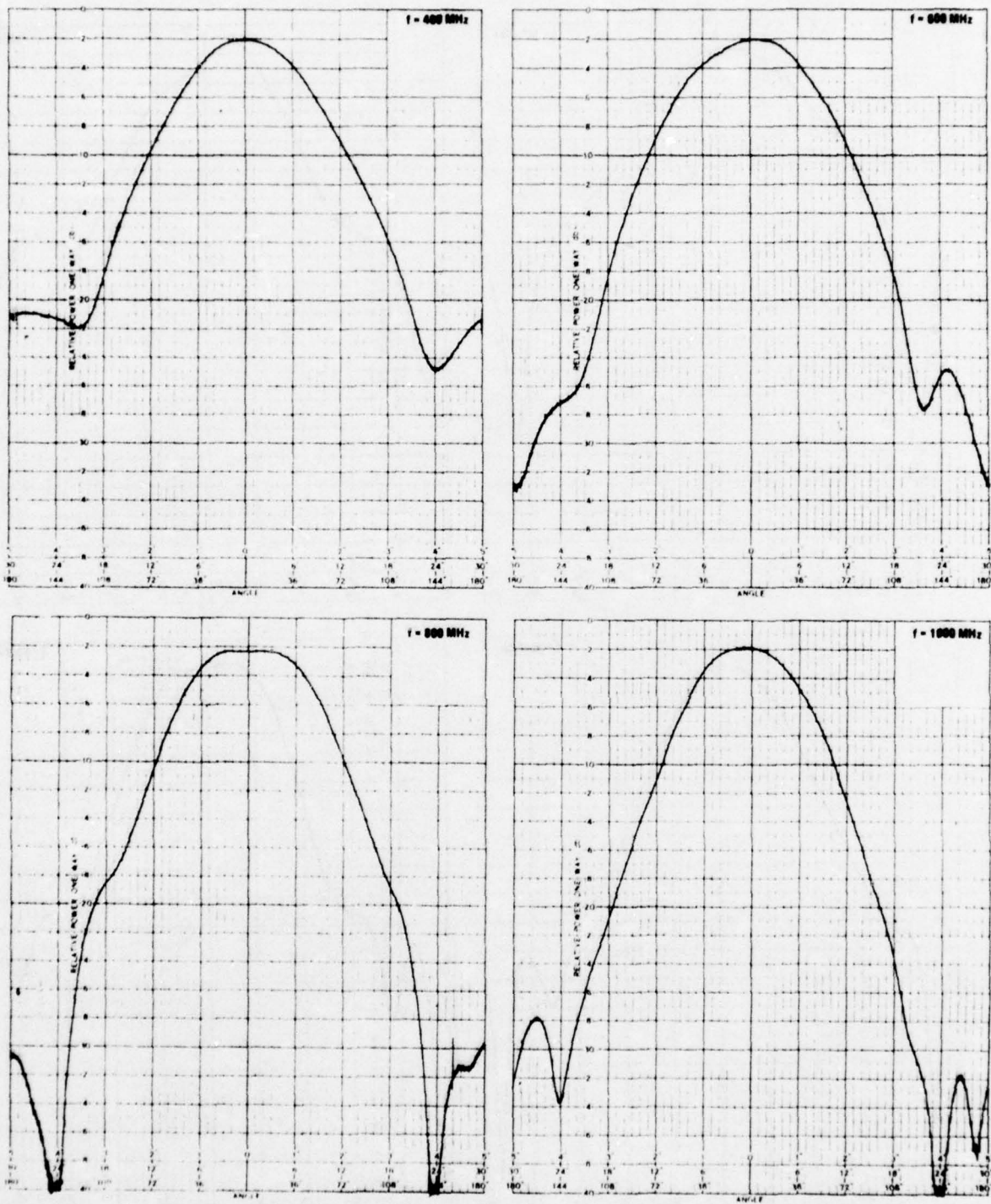

Figure 24. Eθ Patterns for 4-1/8 Inch Hooded Antenna, One Meter Spacing, 400-1000 MHz.

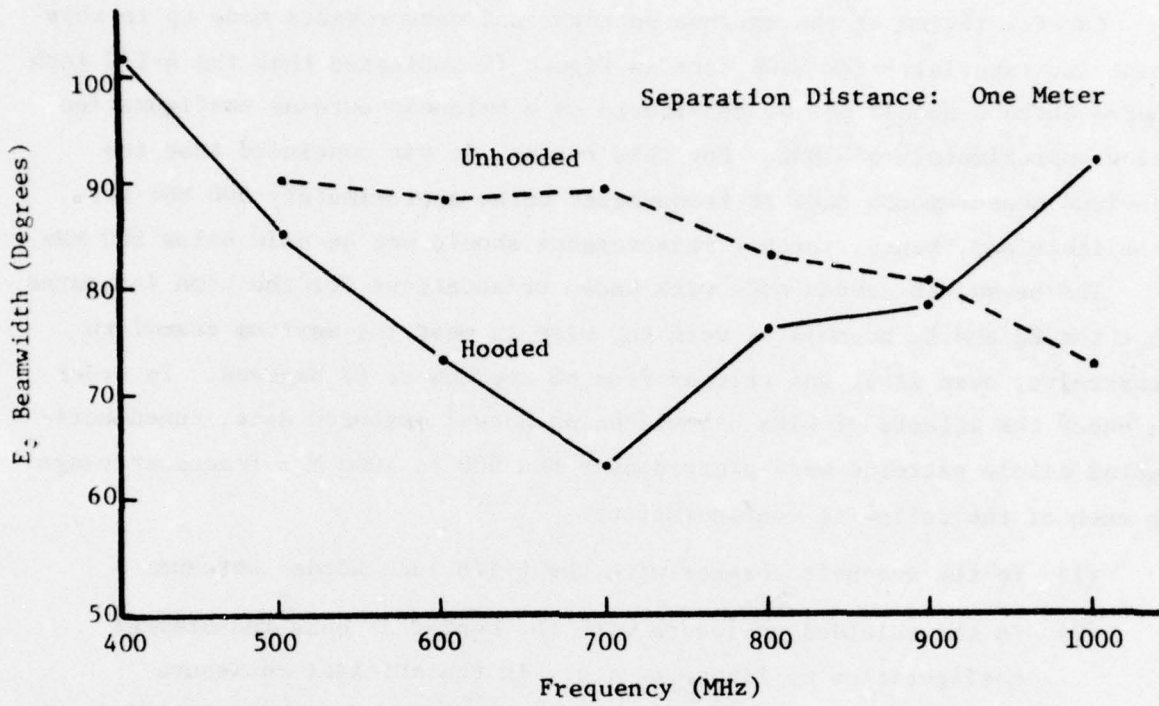

Figure 25. E_{ϕ} Beamwidth for 4-1/8 Inch Hooded Antenna.

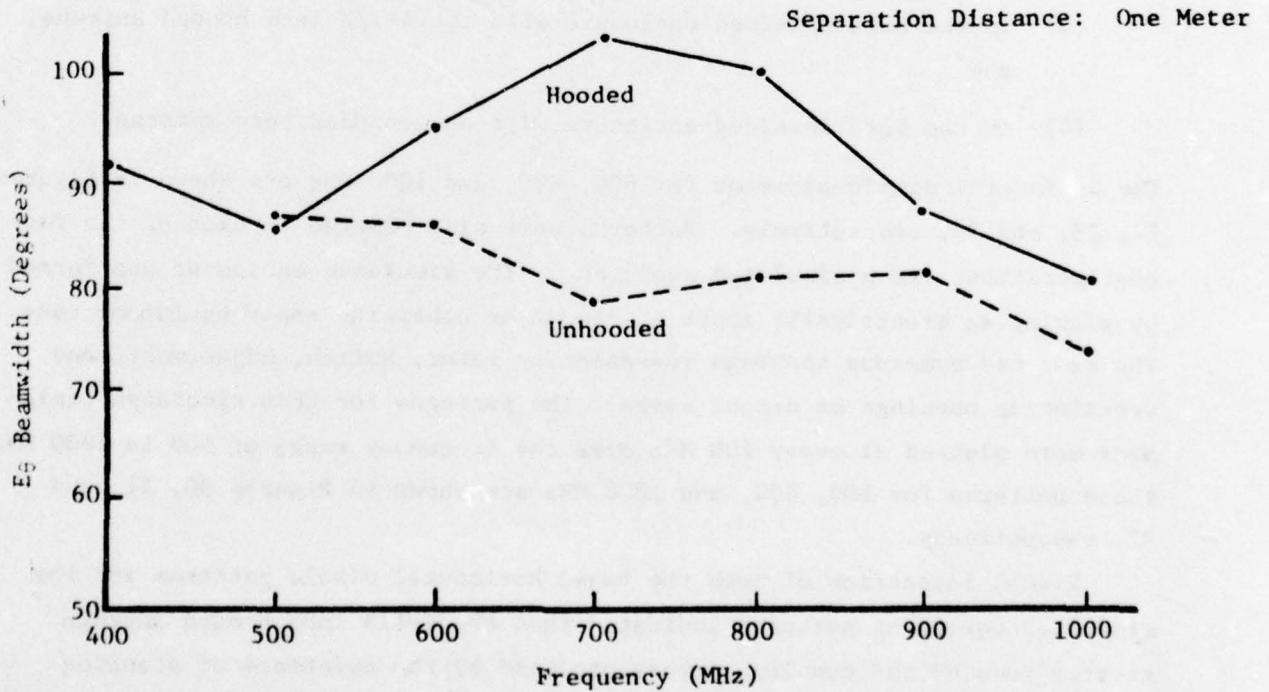

Figure 26. E_{θ} Beamwidth for 4-1/8 Inch Hooded Antenna.

Careful review of the antenna patterns and measurements made up to this point and especially the VSWR data in Figure 19 indicated that the 4-1/8 inch hooded antenna should not be considered as a balanced antenna configuration below approximately 500 MHz. For this reason, it was concluded that the previous measurements made at frequencies below approximately 500 MHz were unreliable and, hence, further measurements should not be made below 500 MHz.

The beamwidth curves made with known orientations for the hood indicated that the E_ϕ and E_θ beamwidths were too wide to meet the maximum beamwidth constraint, even if it was relaxed from 60 degrees to 67 degrees. In order to check the effects of wide beamwidths on actual measured data, tuned horizontal dipole patterns were plotted over the 500 to 1000 MHz frequency range in each of the following configurations:

- (1) In the anechoic chamber with the 4-1/8 inch hooded antenna,
- (2) In the shielded enclosure with the hooded antenna measurement configuration of Figure 4, i.e., in the shielded enclosure with the 4-1/8 inch hooded antenna and with absorbing material on the wall of the enclosure facing the hood,
- (3) In the bare shielded enclosure with the 4-1/8 inch hooded antenna, and
- (4) In the bare shielded enclosure with an unhooded feed antenna.

The horizontal dipole patterns for 600, 800, and 1000 MHz are shown in Figures 27, 28, and 29, respectively. Patterns were also plotted in each of the four configurations for a simulated equipment. The simulated equipment was formed by placing an electrically short dipole in an otherwise empty equipment case. The case had numerous openings representing meter, switch, adjustment, and ventilating openings on actual cases. The patterns for this simulated equipment were plotted at every 100 MHz over the frequency range of 500 to 1000 MHz. These patterns for 600, 800, and 1000 MHz are shown in Figures 30, 31, and 32, respectively.

Visual inspection of both the tuned horizontal dipole patterns and the simulated equipment patterns indicated that the 4-1/8 inch hooded antenna greatly reduced the coupling errors produced by the existence of standing waves in the shielded enclosure. With the exception of the depths of the nulls,

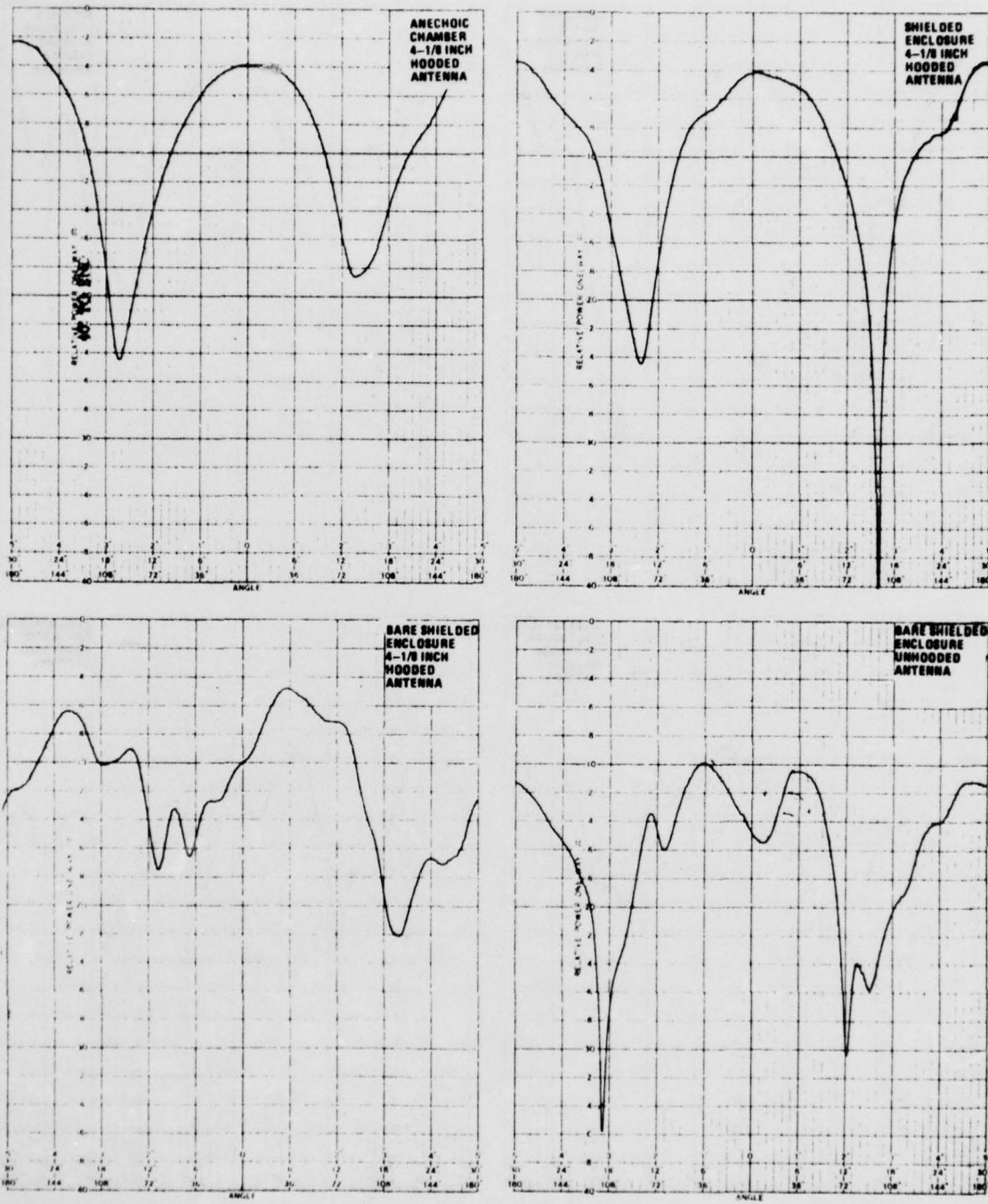

Figure 27. Dipole Patterns for Various Test Configurations, 600 MHz.

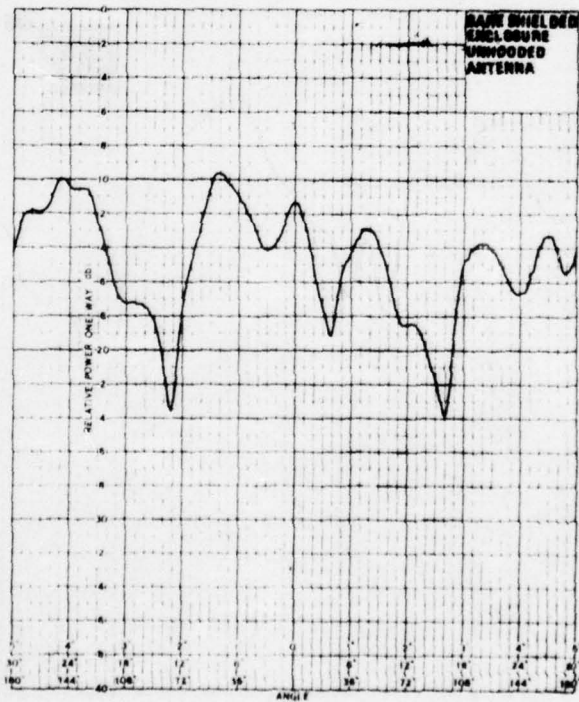
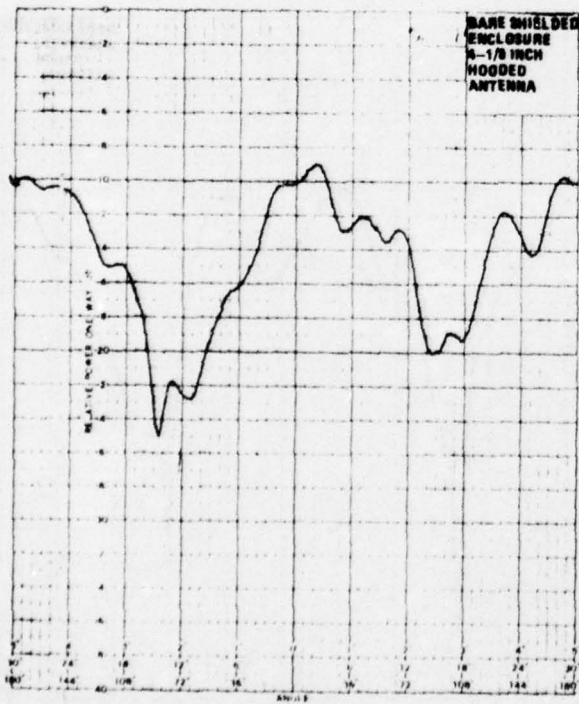
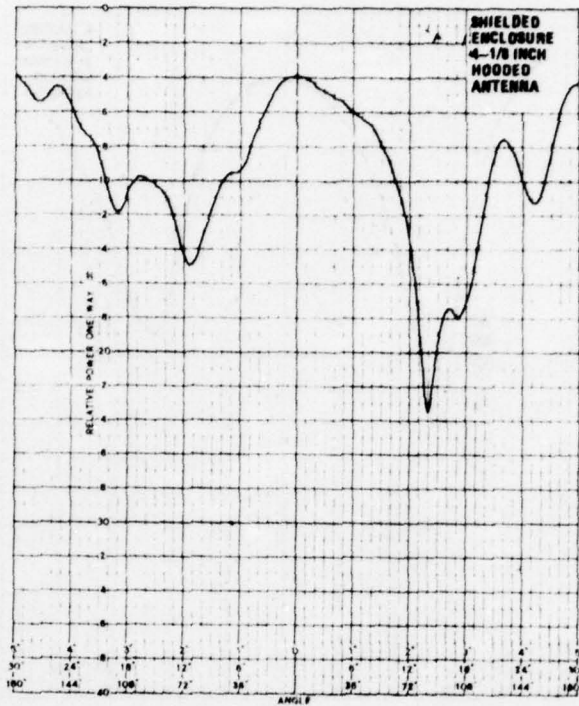
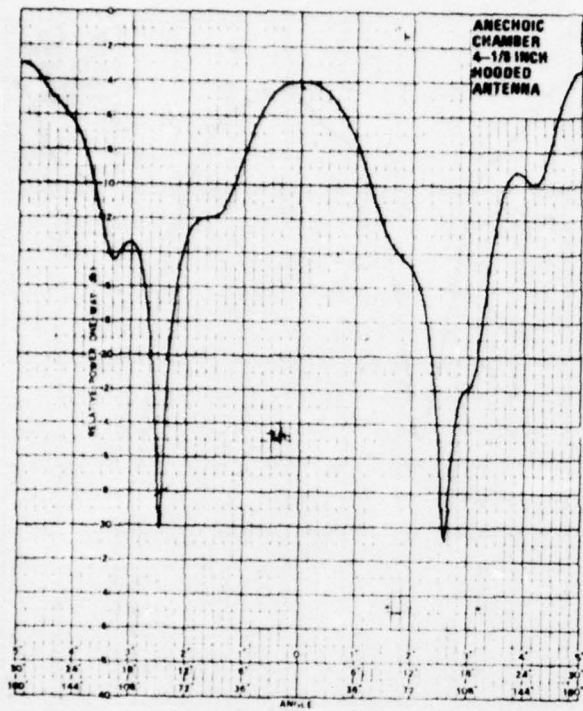

Figure 28. Dipole Patterns for Various Test Configurations, 800 MHz.

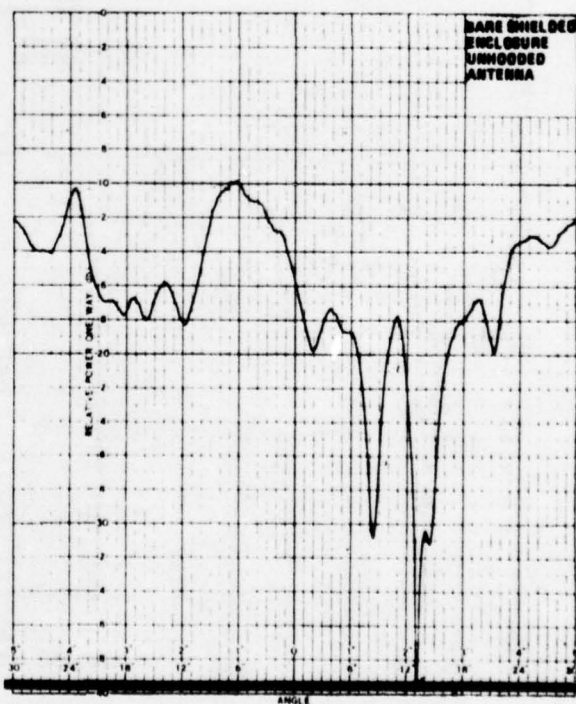
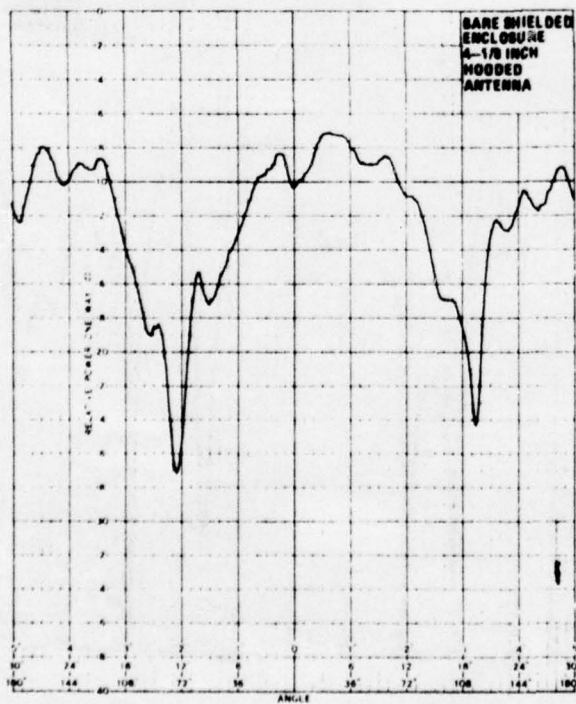
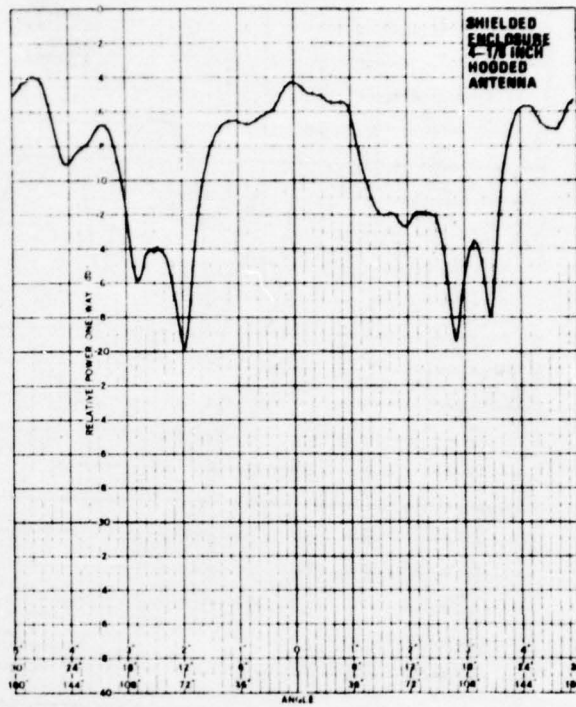
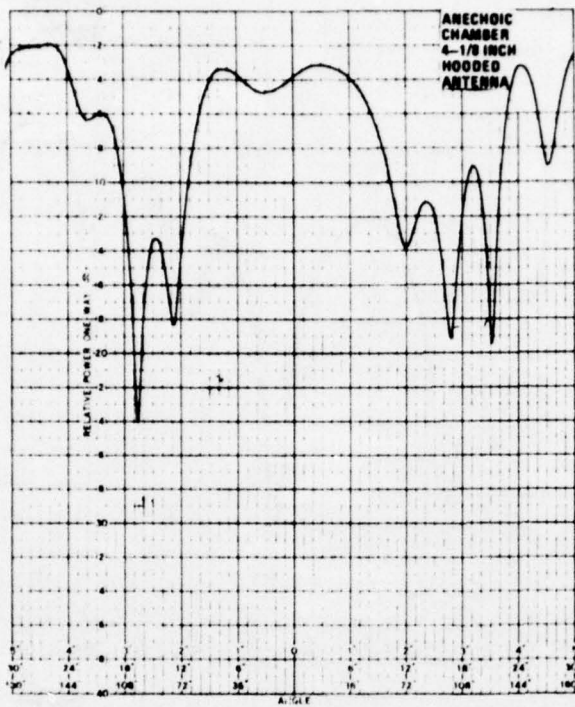

Figure 29. Dipole Patterns for Various Test Configurations, 1000 MHz.

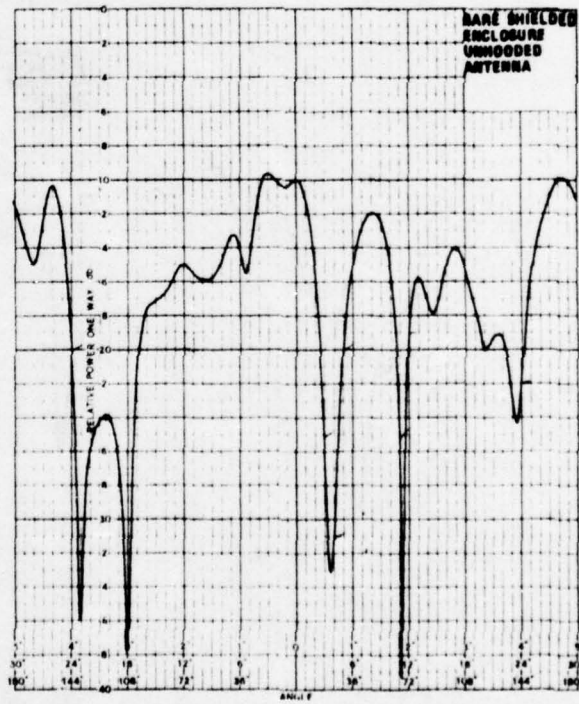
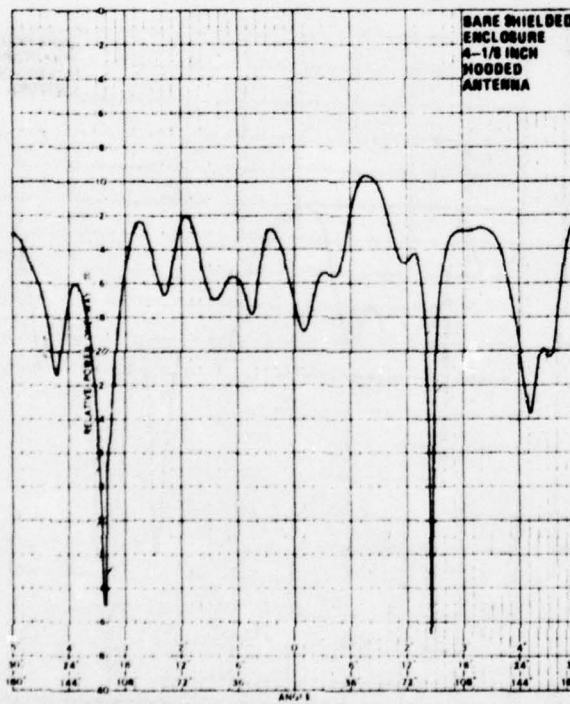
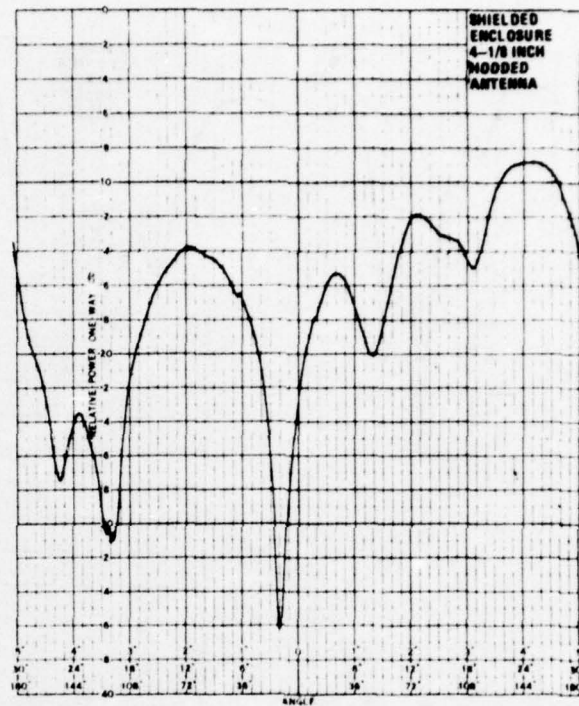
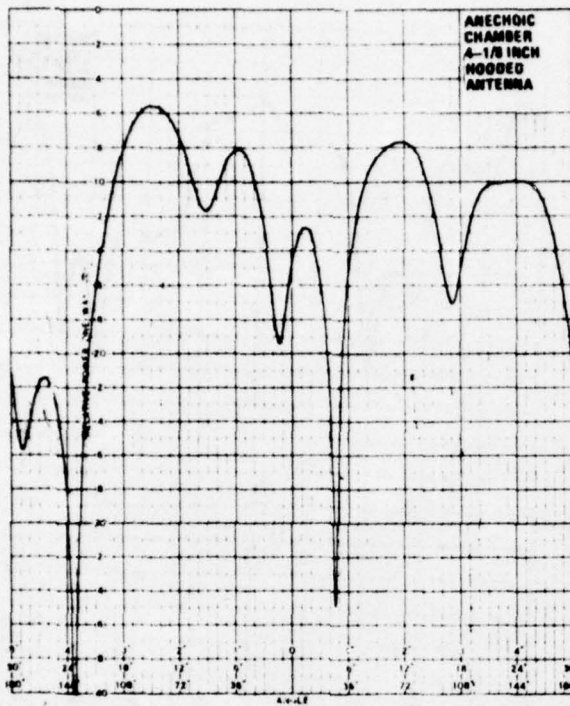

Figure 30. Simulated Equipment Patterns for Various Test Configurations, 600 MHz

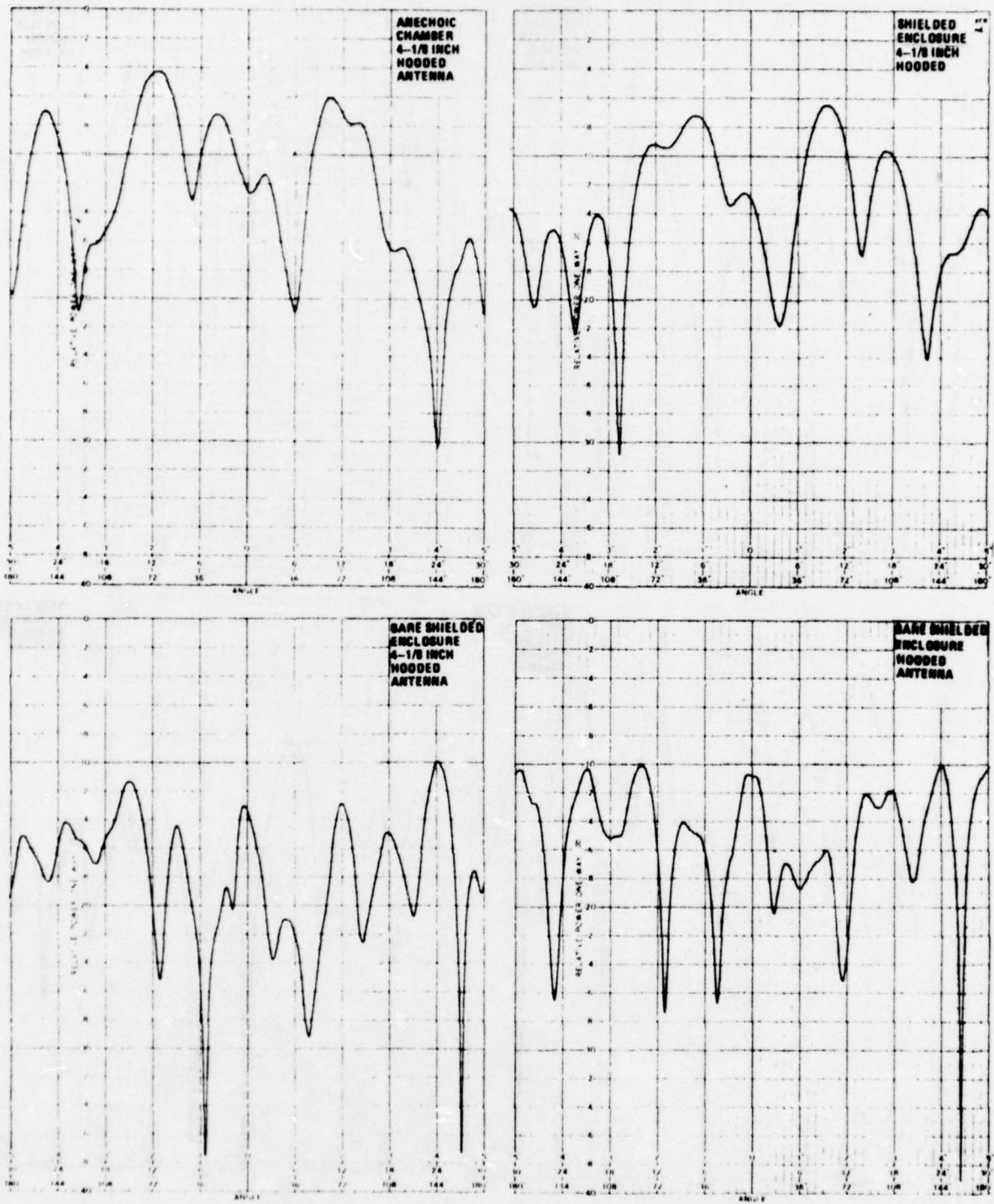

Figure 31. Simulated Equipment Patterns for Various Test Configurations, 800 MHz.

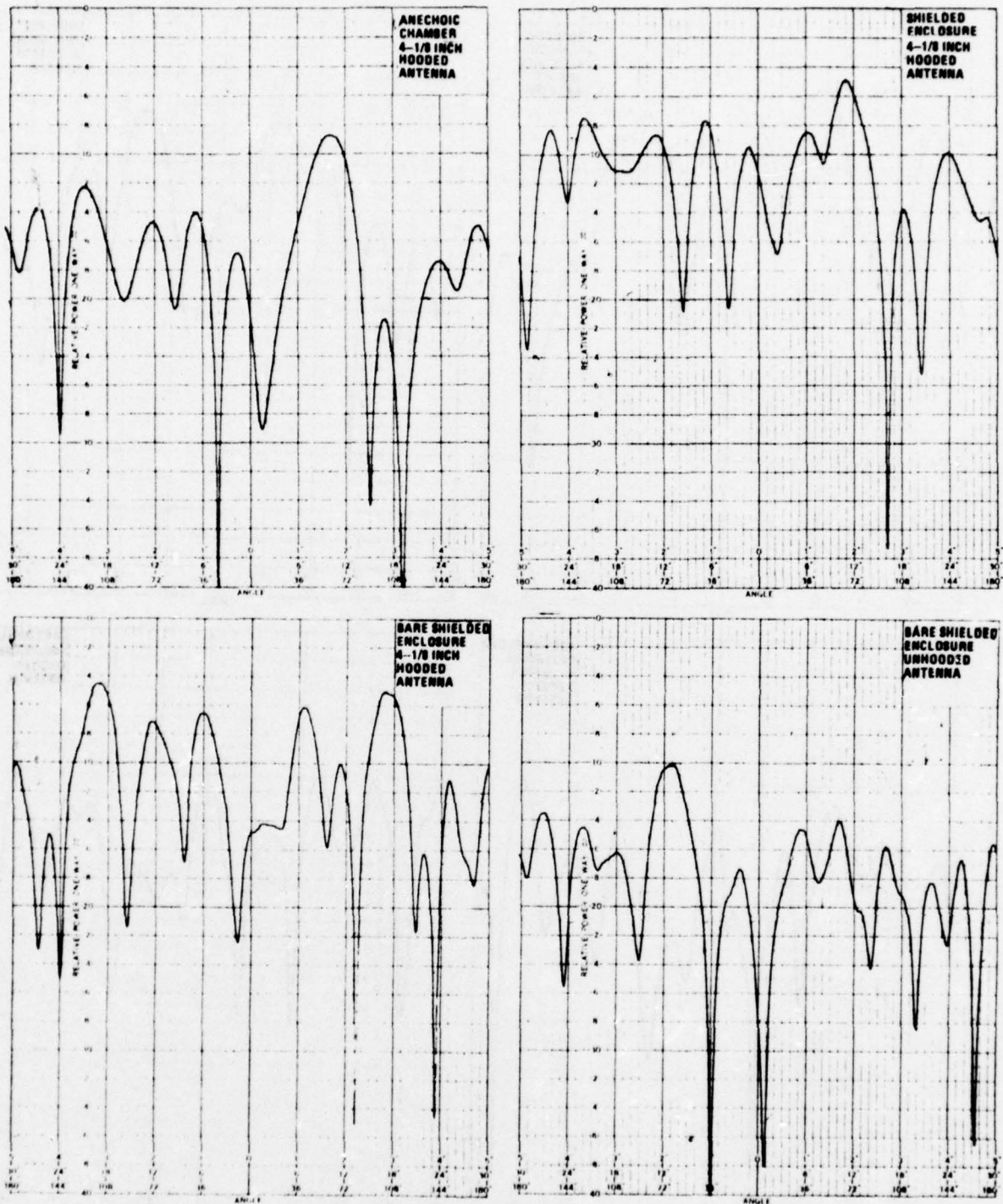

Figure 32. Simulated Equipment Patterns for Various Test Configurations, 1000 M.

the anechoic chamber hooded antenna and the shielded enclosure hooded antenna patterns were essentially equivalent. The degradation resulting from standing waves was obvious in the bare shielded enclosure unhooded patterns.

A statistical technique that can be employed to numerically compare antenna patterns is an evaluation of linear correlation coefficients [30]. These correlation coefficients as applicable to antenna patterns are a measure of the degree of association (relationship) between the amplitudes of two patterns when the pattern amplitudes are paired according to azimuth.

Correlation coefficients were computed to compare patterns obtained in (1) the shielded enclosure with a hooded antenna, (2) a bare shielded enclosure with a hooded antenna, and (3) a bare shielded enclosure with an unhooded antenna to patterns obtained in the anechoic chamber with a hooded antenna. The results of these calculations are presented in Table IV. These correlation coefficients were computed using the antenna pattern amplitude expressed in microvolts, instead of decibels above 1 microvolt, in order to emphasize details of the pattern peaks and de-emphasize the pattern nulls. This was advisable since nulls are less important in this type of measurement and have variations that are not peculiar to shielded enclosure measurements.

The data presented in Table IV indicates that the correlation coefficients for the hooded antenna patterns made in the shielded enclosure are significantly higher than those for the unhooded antenna patterns in the bare shielded enclosure, especially for the dipole. Also for the dipole patterns, the correlation coefficients for the shielded enclosure hooded antenna configuration are more homogeneous with frequency than are those for the bare shielded enclosure with an unhooded antenna configuration. The size of the openings along the seams of the simulated equipment case were not carefully controlled from one test to another; consequently, the correlation coefficients for the simulated equipment case are lower and vary more with frequency than those for the dipole. However, the tests indicate that the shielded enclosure hooded antenna configuration provides results more closely approximating anechoic chamber results than does the bare shielded enclosure unhooded antenna configuration.

TABLE IV

CORRELATION COEFFICIENTS FOR THE 4-1/8 INCH HOOD COMPARING PATTERNS
OF THREE CONFIGURATIONS TO THE ANECHOIC CHAMBER PATTERN

Frequency (MHz)	Tuned Horizontal Dipole			Simulated Equipment Case		
	Shielded Enclosure Hooded	Bare Shielded Enclosure Hooded	Bare Shielded Enclosure Unhooded	Shielded Enclosure Hooded	Bare Shielded Enclosure Hooded	Bare Shielded Enclosure Unhooded
600	0.9598	0.0215	0.7479	0.3415	0.1387	-0.1830
800	0.9137	0.8632	0.4663	0.4666	-0.2751	-0.2391
1000	0.8919	0.6227	0.5638	0.7430	0.1386	0.2877

4.4.3.3 Eight Inch Hooded Antenna

Based on these tuned horizontal dipole and simulated equipment case patterns and on the correlation coefficients, it was evident that the 4-1/8 inch hood, even with its wide beamwidth, provided a significant improvement in coupling errors relative to the radiated configuration specified in MIL-STD-462. However, it was desirable to determine the degree of improvement, if any, that could be achieved over this same frequency range but with a longer hood having a narrower beamwidth. To determine this possible improvement, a hooded antenna with a fixed length of approximately eight inches was built and evaluated. Its inside and outside diameters were 23-1/2 inches and 21-5/8 inches, respectively, and its actual length was 8-1/2 inches. The AEL Model ASN 113A cavity-backed spiral was used as the probe antenna and Eccosorb Type NZ-1 Absorbing Material was used to line the inside of the hood.

The gain relative to a $\lambda/2$ dipole and the VSWR referred to 50 ohms were measured for this 8-1/2 inch hooded antenna over the 500 to 1000 MHz frequency range. The measured gain relative to a horizontal dipole radiating source and relative to a vertical dipole radiating source are shown as the top curves in Figure 33. A one meter separation distance between antennas was maintained. The gain curves for the unhooded antenna are also shown for reference. The average gain of the 8-1/2 inch hooded antenna relative to a $\lambda/2$ dipole is approximately -2.5 dB. The VSWR of this hooded antenna is shown as the lower curve of Figure 33. The average VSWR relative to 50 ohms is approximately 1.8.

Both the E_ϕ and E_θ patterns of the 8-1/2 inch hood were plotted with a one meter separation distance at each 100 MHz between 500 and 1000 MHz, inclusive. Representative E_ϕ and E_θ patterns are shown in Figures 34 and 35, respectively. The E_ϕ and E_θ half-power beamwidths for all the patterns are shown in Figures 36 and 37, respectively. For comparison, the beamwidths of the 4-1/8 inch hooded antenna and the unhooded antenna are also shown in these figures. The 8-1/2 inch hood improved the E_ϕ beamwidth by eleven or more degrees relative to the unhooded antenna at all frequencies. Increasing the hood length to 8-1/2 inches provided only a slight improvement in the E_ϕ beamwidth up to approximately 700 MHz; however, above 700 MHz, the degree of

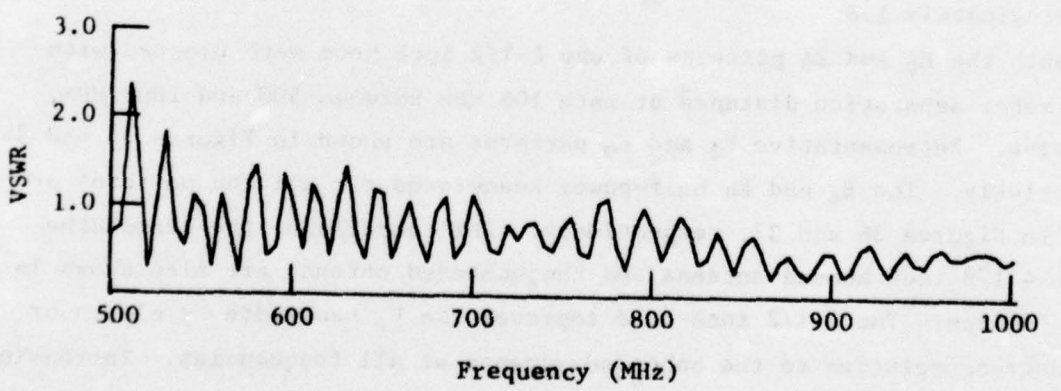
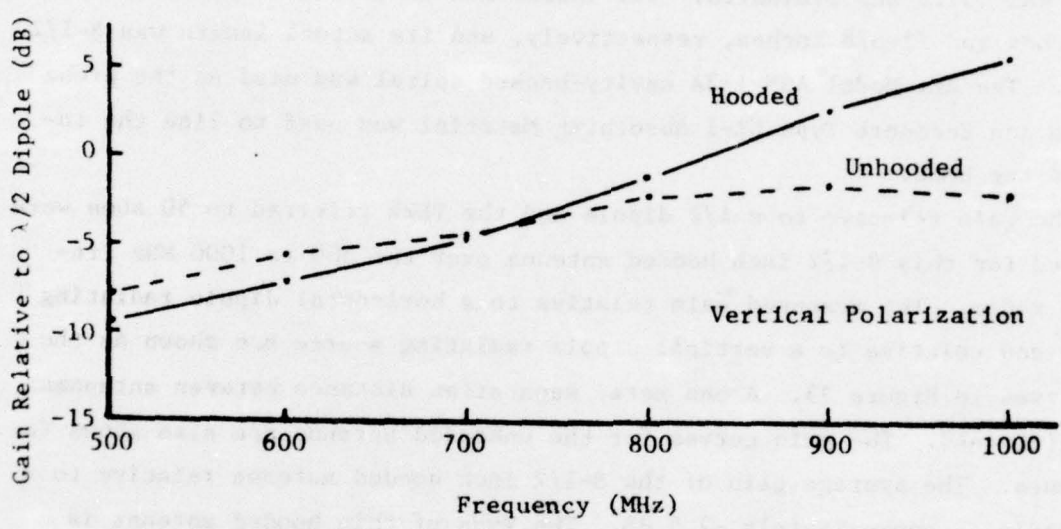
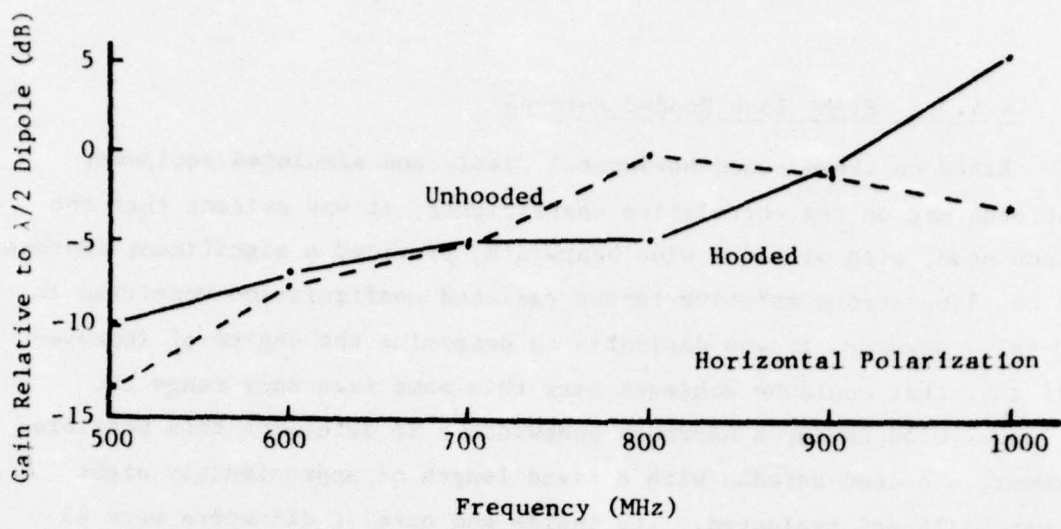

Figure 33. Gain and VSWR of 8-1/2 Inch Hooded Antenna.

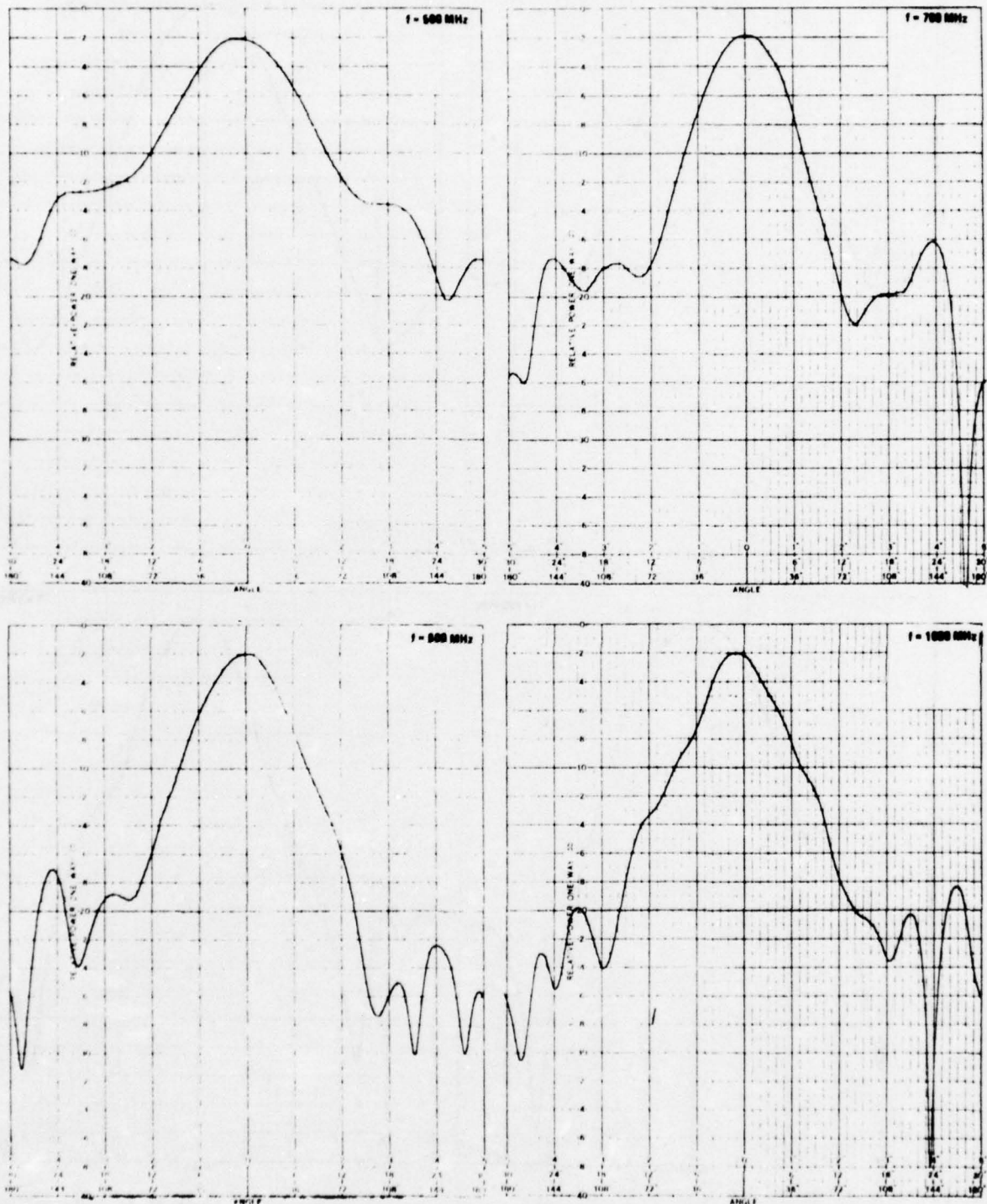

Figure 34. E_{θ} Patterns For 8-1/2 inch Hooded Antenna, One Meter Spacing, 500-1000 MHz.

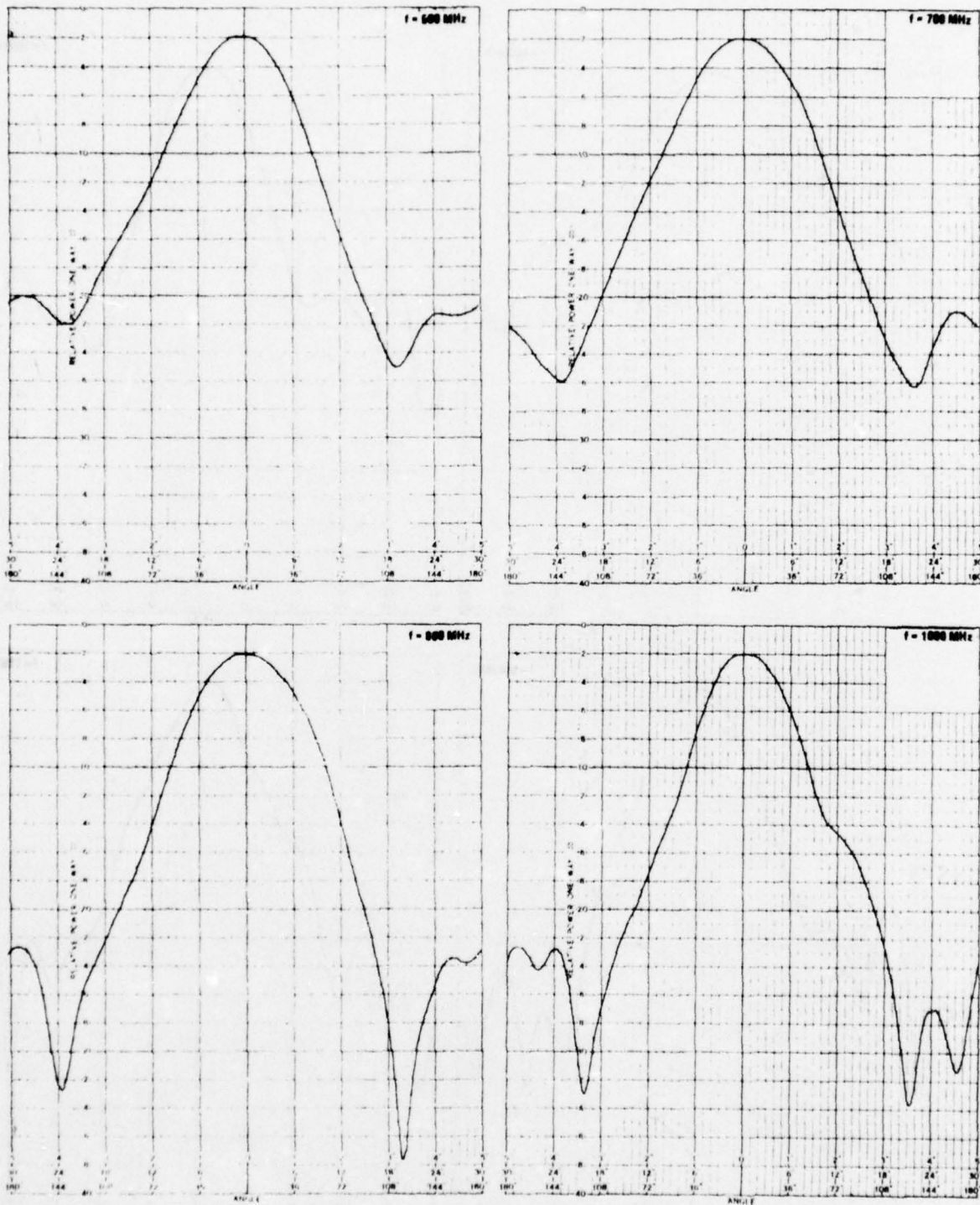

Figure 35. E0 Patterns for 8-1/2 Inch Hooded Antenna, One Meter Spacing, 500-1000 MHz.

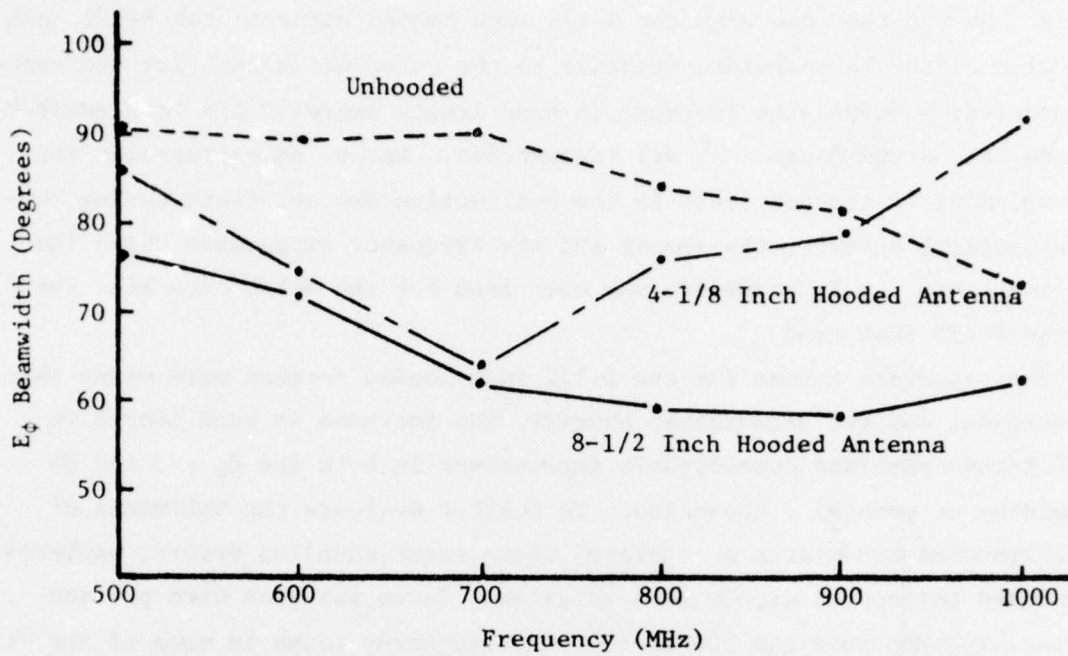

Figure 36. E_ϕ Beamwidth for 4-1/8 and 8-1/2 Inch Hooded Antennas.

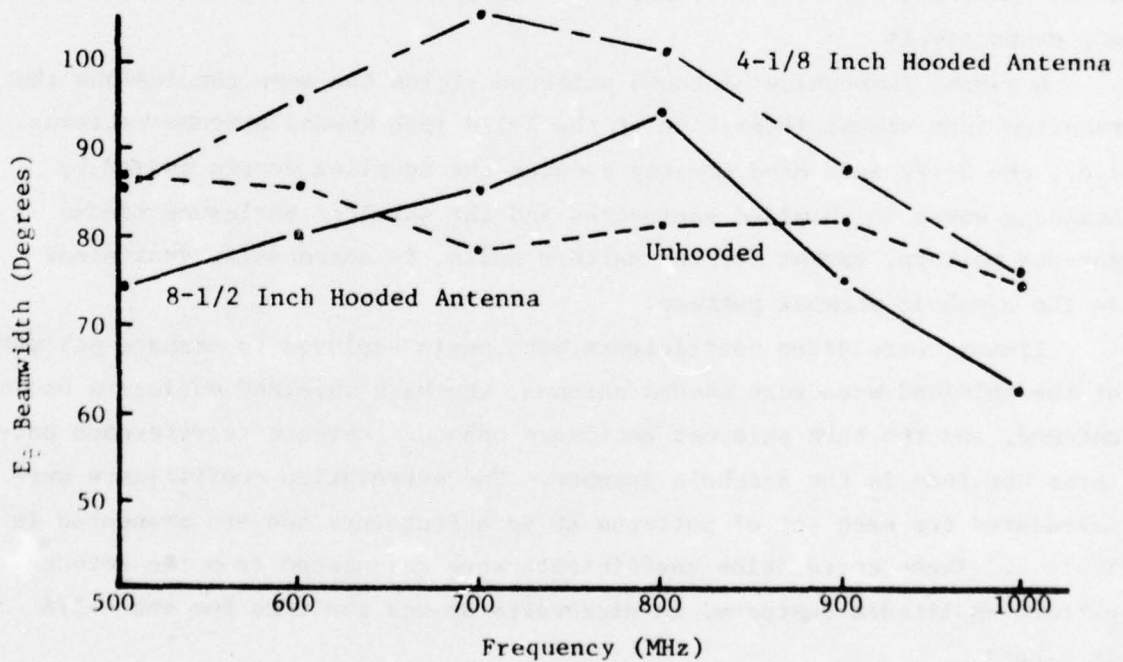

Figure 37. E_θ Beamwidth for 4-1/8 and 8-1/2 Inch Hooded Antennas.

improvement due to the increased hood length increases with increasing frequency. As was the case with the 4-1/8 inch hooded antenna, the 8-1/2 inch hood widened the E_{θ} beamwidth relative to the unhooded antenna for the center frequencies; however, the increase in hood length improved the E_{θ} beamwidth by more than seven degrees at all frequencies. Again, an explanation for this widening of the beamwidth in the θ -direction was not found during this investigation; however, the amount and the frequency range over which the hood increased the E_{θ} beamwidth was much less for the 8-1/2 inch hood than for the 4-1/8 inch hood.

The beamwidth curves for the 8-1/2 inch hooded antenna were wider than the original desired beamwidths; however, the increase in hood length to 8-1/2 inches provided considerable improvement in both the E_{ϕ} and the E_{θ} beamwidths at several frequencies. To further evaluate the influence of these improved bandwidths on radiated measurement coupling errors, patterns of a tuned horizontal dipole were obtained. These patterns were plotted at every 100 MHz over the 500 to 1000 MHz frequency range in each of the four configurations described for the 4-1/8 inch hooded antenna. The horizontal dipole patterns for 600, 800, and 1000 MHz are shown in Figures 38, 39, and 40, respectively.

A visual inspection of these patterns yields the same conclusions that resulted from visual inspection of the 4-1/8 inch hooded antenna patterns, i.e., the 8-1/2 inch hood greatly reduces the coupling errors caused by standing waves in shielded enclosures and the shielded enclosure hooded antenna pattern, except for the pattern nulls, is essentially equivalent to the anechoic chamber pattern.

Linear correlation coefficients were again employed to compare patterns of the shielded enclosure hooded antenna, the bare shielded enclosure hooded antenna, and the bare shielded enclosure unhooded antenna to reference patterns obtained in the anechoic chamber. The correlation coefficients were calculated for each set of patterns at each frequency and are presented in Table V. These correlation coefficients were calculated from the antenna pattern amplitudes expressed in microvolts as was the case for the 4-1/8 inch hood.

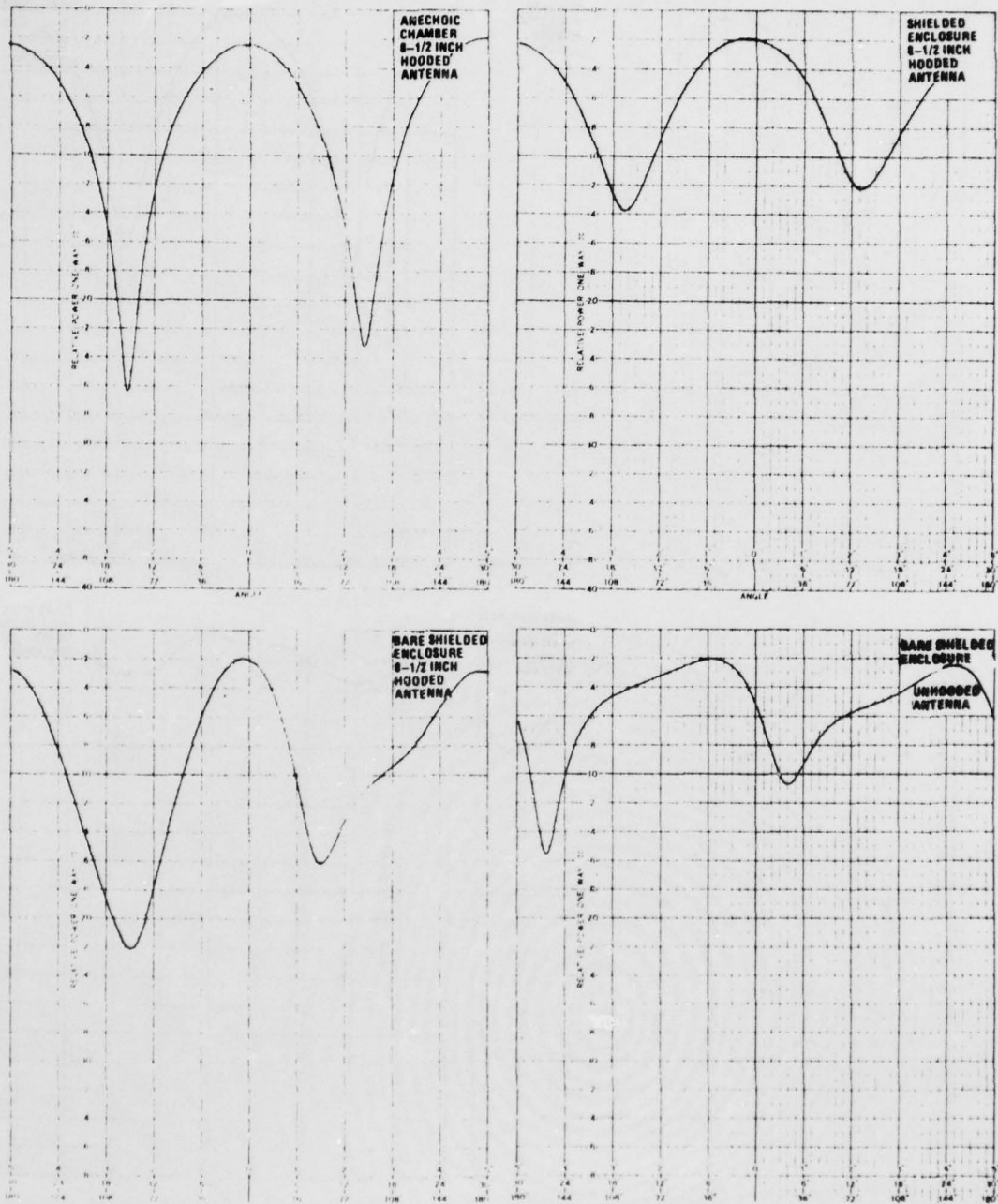

Figure 38. Dipole Patterns for Various Test Configurations, 600 Mhz.

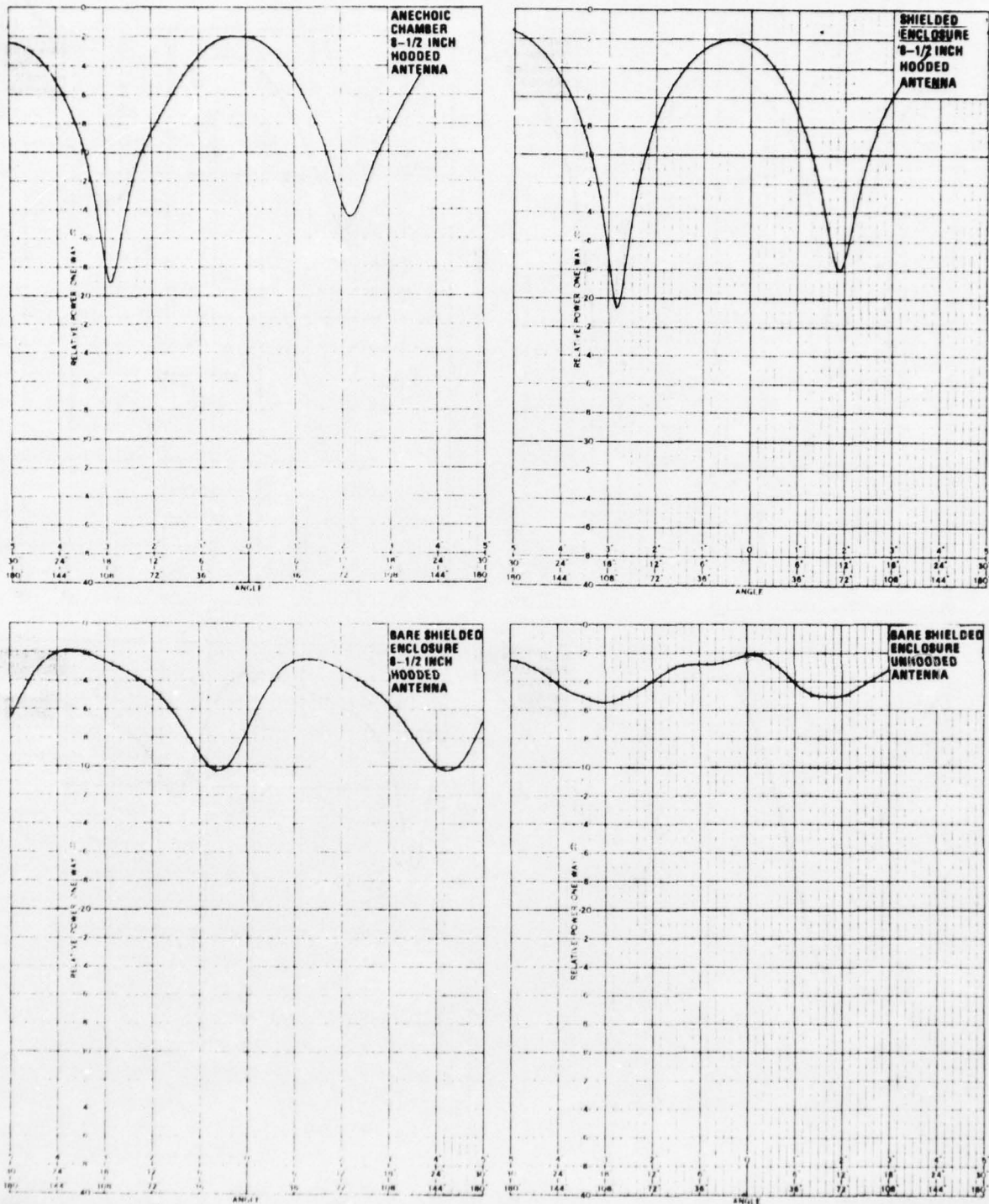

Figure 39. Dipole Patterns for Various Test Configurations, 800 MHz.

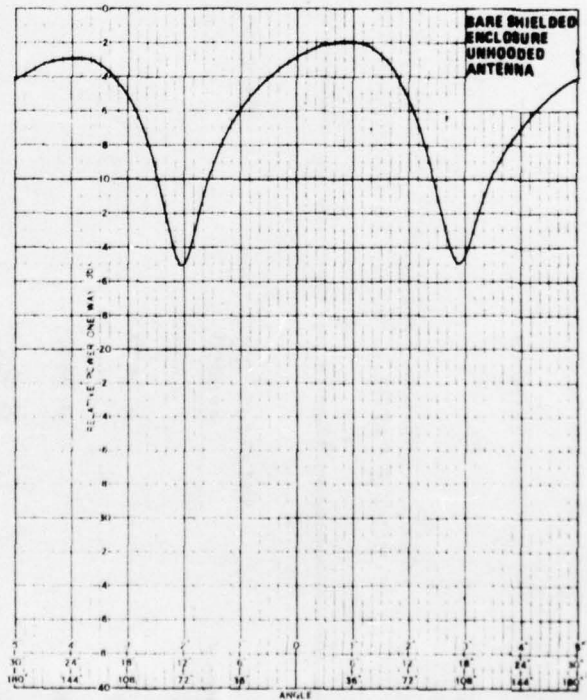
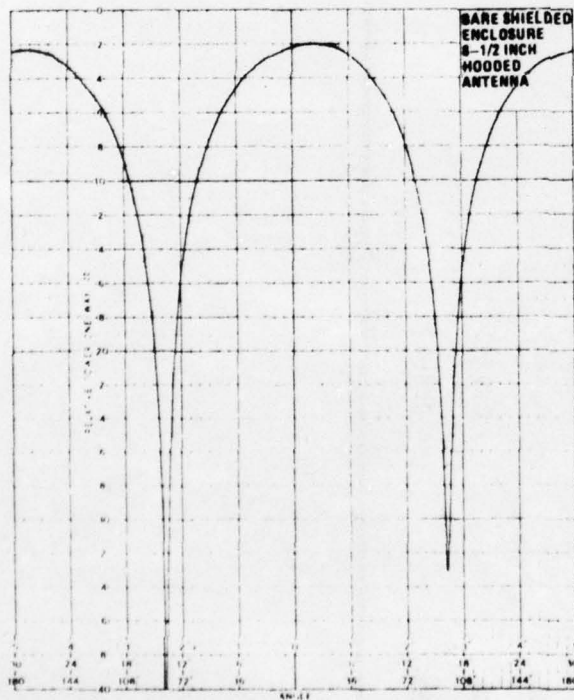
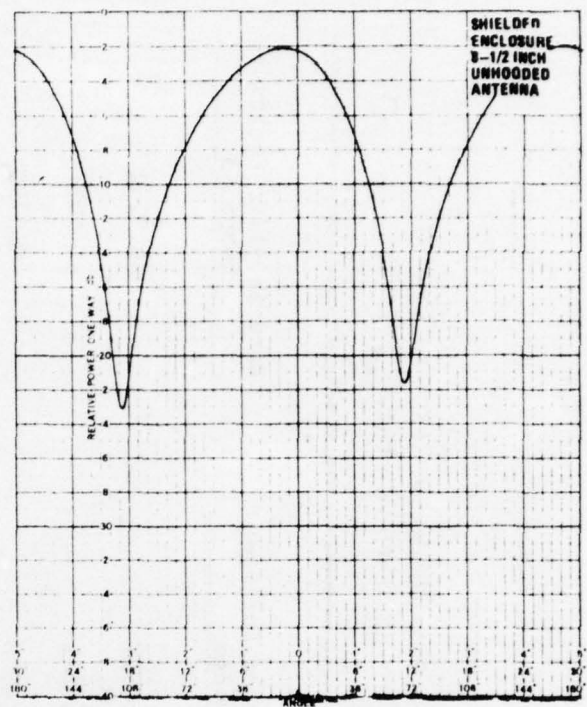
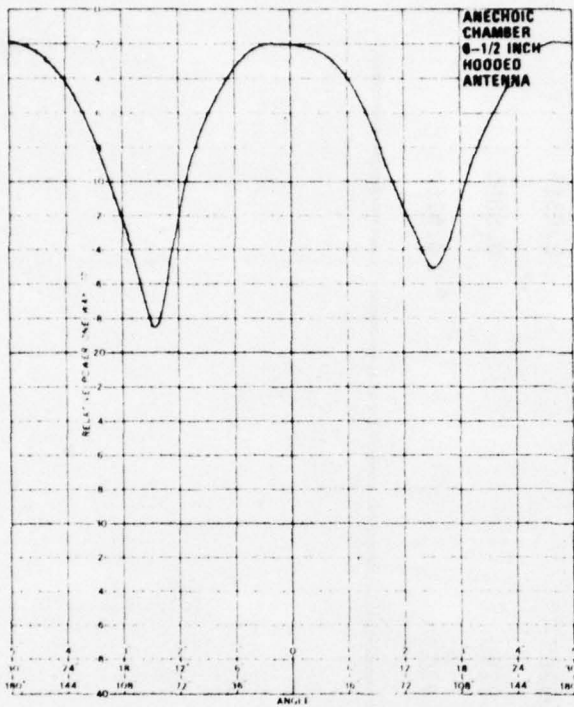

Figure 40. Dipole Patterns for Various Test Configurations, 1000 Mhz.

TABLE V

CORRELATION COEFFICIENTS FOR THE 8-1/2 INCH HOOD COMPARING TUNED HORIZONTAL
 DIPOLE PATTERNS OF THREE CONFIGURATIONS TO THE ANECHOIC CHAMBER PATTERN

Frequency (MHz)	Shielded Enclosure		Bare Shielded Enclosure	
	Hooded	Unhooded	Hooded	Unhooded
500	0.8970	-0.9152	0.4971	-0.9152
600	0.9812	-0.1097	0.8872	-0.1097
700	0.9425	0.8280	0.4938	0.8280
800	0.9425	0.8586	-0.6265	0.8586
900	0.9752	0.8865	0.7298	0.8865
1000	0.8627	0.6269	0.9203	0.6269

These data show that the hooded antenna in the shielded enclosure yields a much more accurate radiated measurement than does an unhooded antenna in the bare shielded enclosure. Furthermore, correlation coefficients for the shielded enclosure hooded antenna configurations are significantly more homogeneous than those for either of the other two configurations. At this point it should be noted that both the patterns and the correlation coefficients for the bare shielded enclosure unhooded antenna configuration can and will vary drastically with only minor frequency variations. This results because of the high dependence of the standing waves on frequency within the shielded enclosure.

A comparison of the correlation coefficient data in Tables IV and V indicates that increasing the hood length in general (1) improved the correlation of the shielded enclosure hooded antenna configuration to the anechoic chamber configuration, and (2) improved the correlation of the bare shielded enclosure hooded antenna configuration to the anechoic chamber configuration. Similarly, a comparison of the beamwidth data in Figures 25 and 26 to that in Figures 36 and 37, respectively, shows a significant improvement, i.e., decrease, in beamwidth with the increased hood length. It is noted the beamwidth is still wider than desired and this implies that even better measurement accuracy could be obtained with a hood length greater than 8-1/2 inches; however, other tradeoff factors such as size, weight, cost, etc. must be thoroughly considered before deciding that a longer hood should be used.

Based on all the evaluations, i.e., recorded patterns and the measured gain and VSWR of both the 4-1/8 inch hood and the 8-1/2 inch hood, it was concluded that a significant improvement in radiated measurements within a shielded enclosure over the 500 to 1000 MHz frequency range can be achieved with an 8-1/2 inch hooded antenna.

4.4.3.4 Additional Considerations

In a research program of this type, it is seldom that sufficient investigations are possible to explain all of the observed effects or substantiate all of the hypotheses that surface during detailed data analysis. However, it is necessary that these effects and hypotheses be documented

and probable explanations and substantiations be offered. These paragraphs document two observed effects plus one hypothesis and offer explanations and/or substantiation for each.

During data analysis, it was observed that the unhooded tuned horizontal dipole pattern at 900 MHz in the bare shielded enclosure configuration closely approximated that of the ideal dipole pattern. Obviously, if this were the case at all other frequencies, there would be no need for an improved measurement procedure. Earlier data, however, had clearly indicated that this was not the case and that this observed effect was a coincidental occurrence with a high degree of frequency dependence. To determine the frequency dependence of both the bare shielded enclosure unhooded antenna and the shielded enclosure hooded antenna configurations, tuned horizontal dipole patterns were plotted for every 100 ± 2 MHz between 500 and 1000 MHz inclusive. Representative patterns for the bare shielded enclosure unhooded antenna configuration are shown in Figures 41 and 42 while comparable patterns for the shielded enclosure hooded antenna configuration are shown in Figure 43 and 44. As was expected, Figures 41 and 42 show that the patterns made with the bare shielded enclosure unhooded antenna configuration vary drastically with only small frequency changes. Also, Figures 43 and 44 show that the patterns made with the shielded enclosure hooded antenna configuration are insensitive to small frequency variations. Therefore, in spite of the fact that, at a few discrete frequencies, relatively accurate measurements can be made with the bare shielded enclosure unhooded antenna configuration, these patterns support the earlier expectation that in general such measurements are in error and, hence, will yield unreliable radiated data.

In another situation, an apparent anomaly was observed as tuned horizontal dipole patterns were being plotted with the 8-1/2 inch hooded antenna. As shown in Figure 45, the peak-to-null ratio of the pattern for the shielded enclosure hooded antenna configuration was only 2.8 dB at 702 MHz, while at 700 MHz this ratio was 13.4 dB and at 704 MHz it was 18 dB. These abrupt pattern variations as a function of frequency were unexpected with this configuration; therefore, investigative tests were conducted in an attempt to determine their cause. The dipole patterns were first plotted at the same frequencies in the anechoic chamber to verify that the anomaly was related to

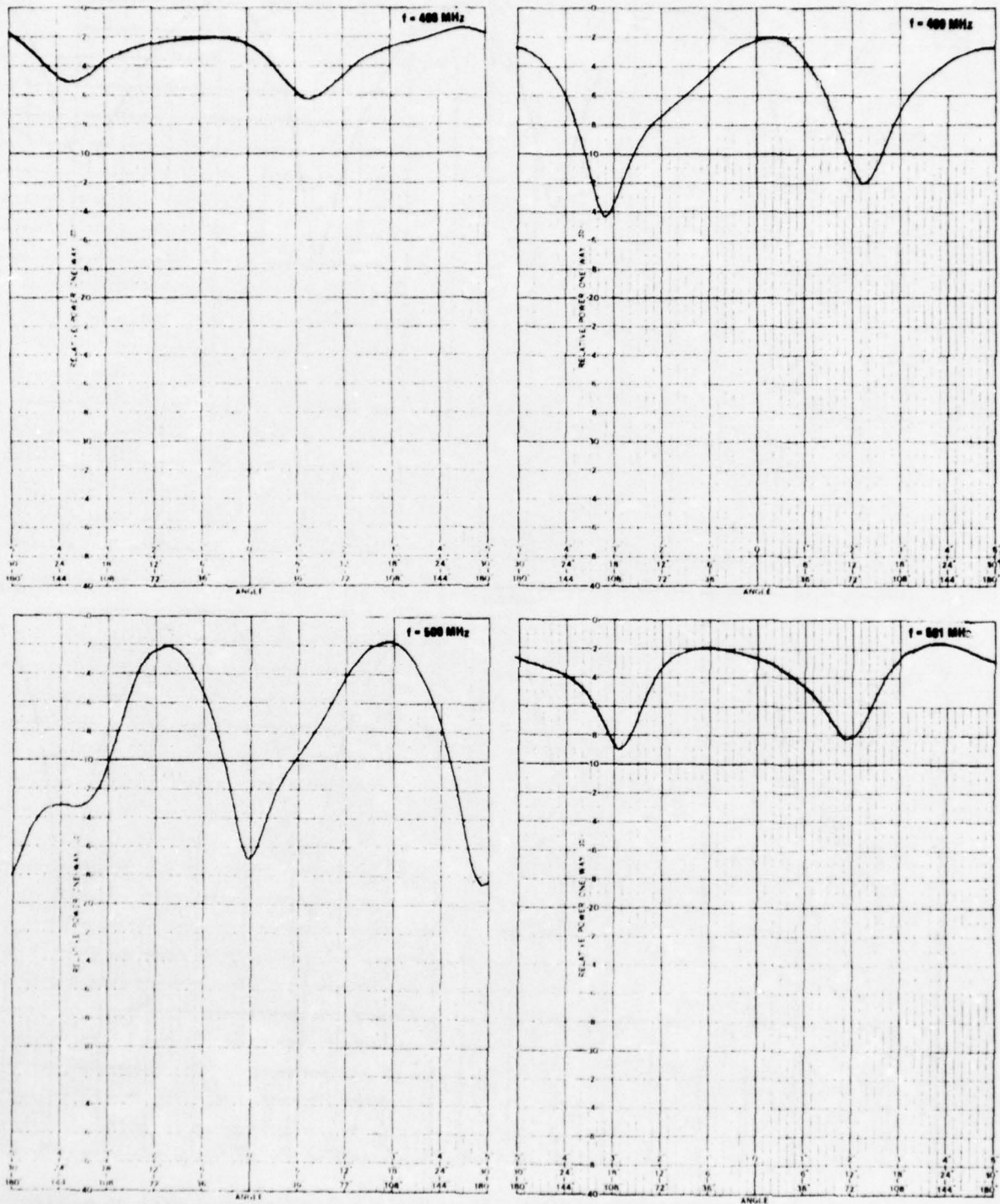

Figure 41. Dipole Patterns in Bare Shielded Enclosure With Unhooded Antenna, 498-501 MHz.

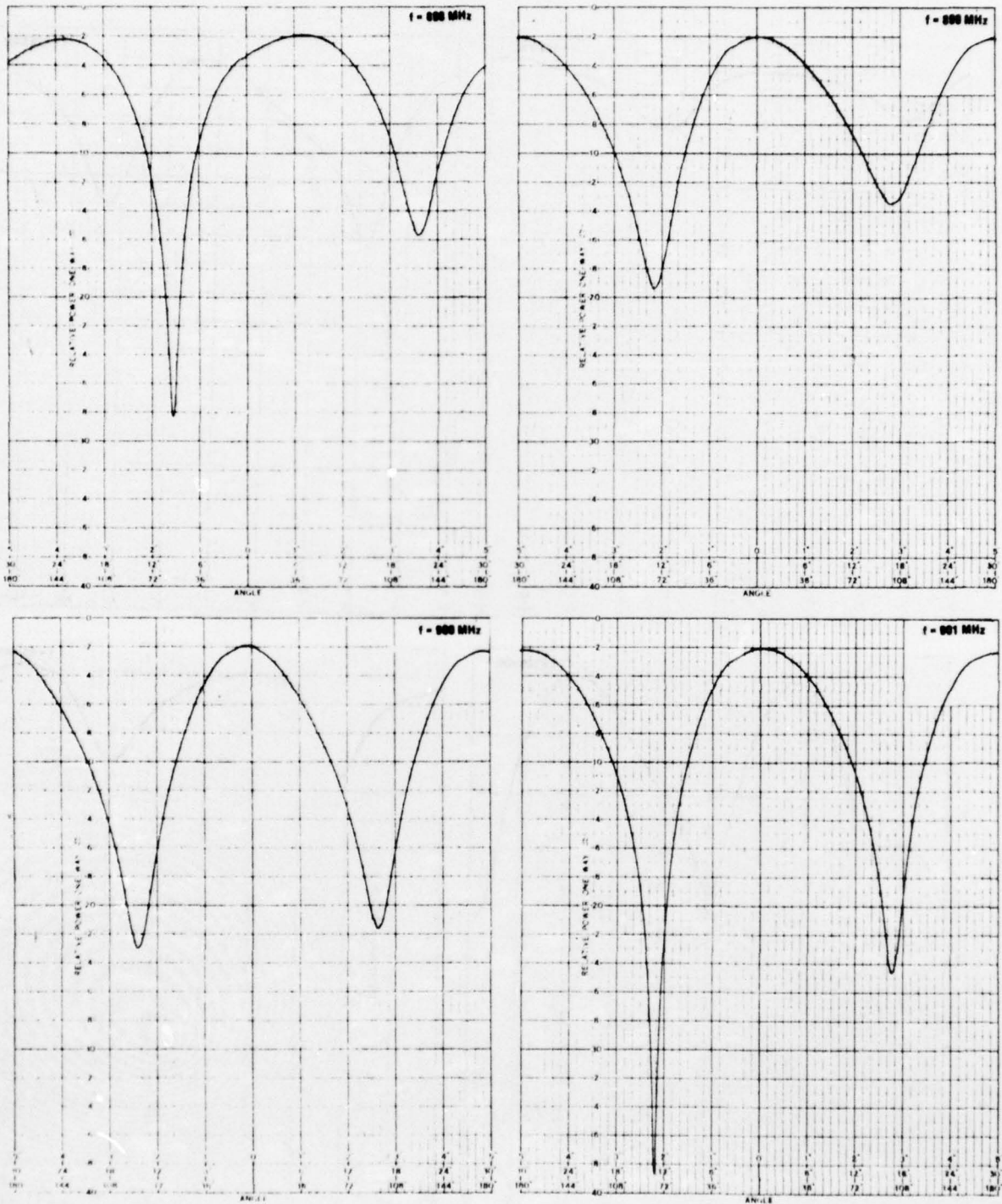

Figure 42. Dipole Patterns in Bare Shielded Enclosure With Unhooded Antenna, 898-901.

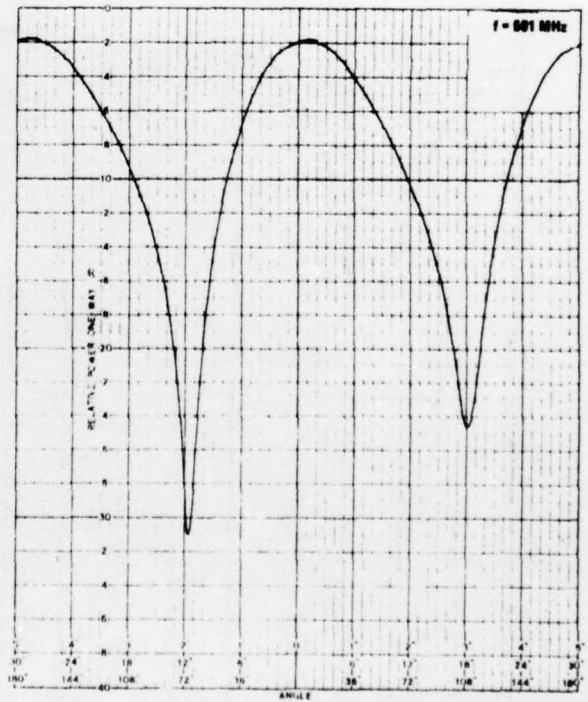
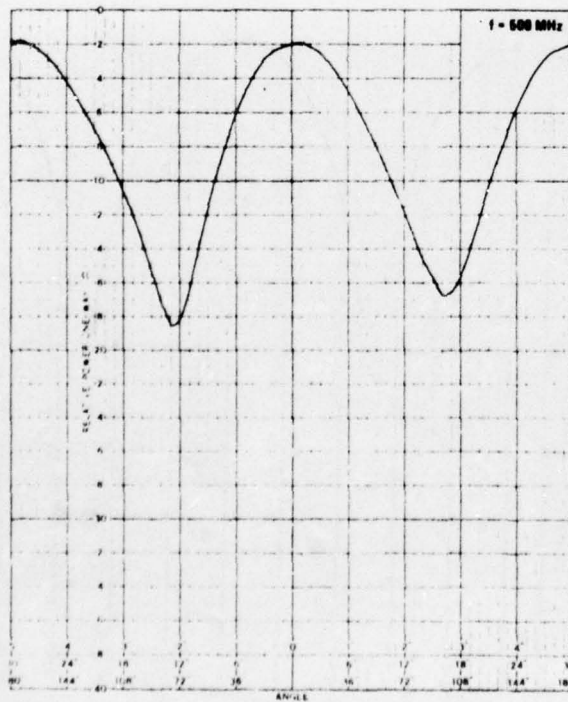
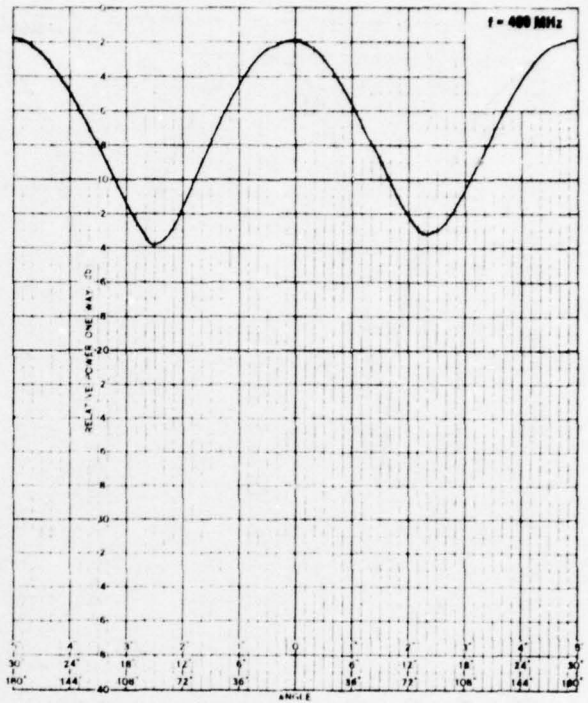
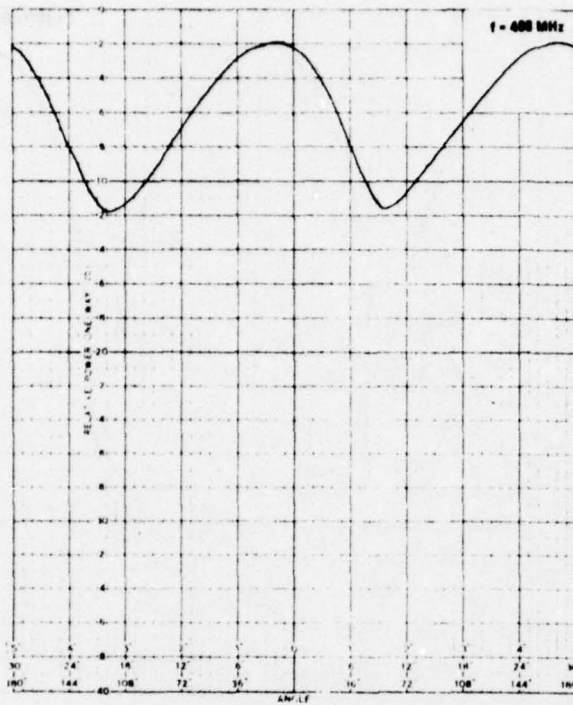

Figure 43. Dipole Patterns in Shielded Enclosure With Hooded Antenna, 498-501M.

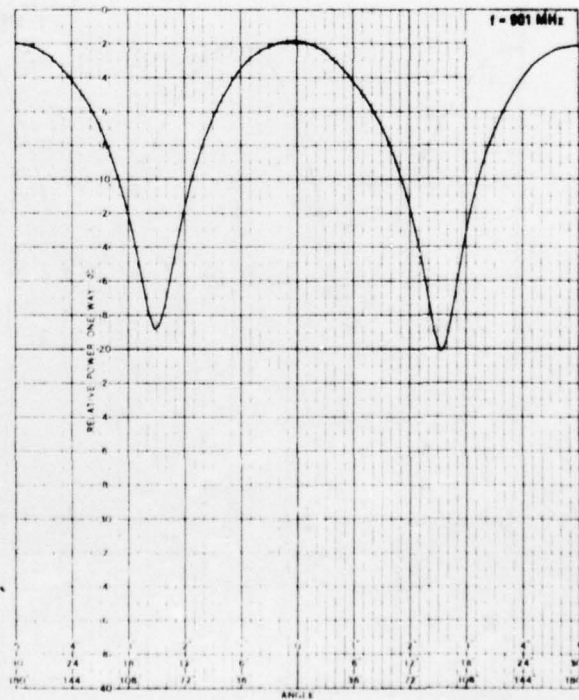
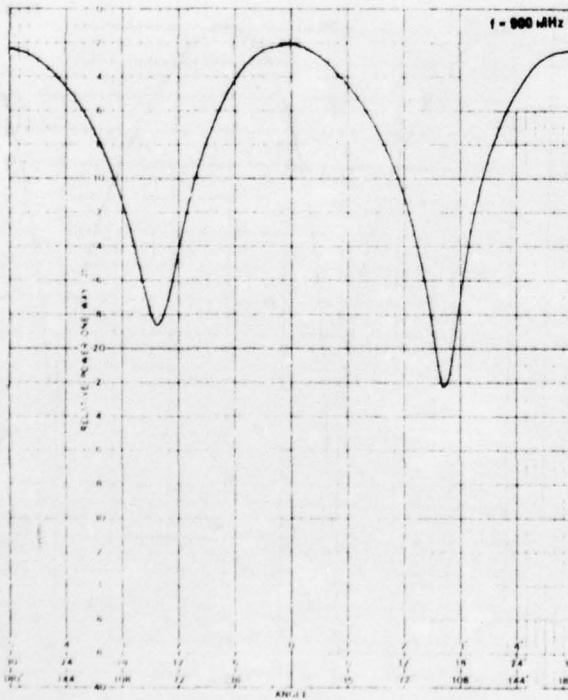
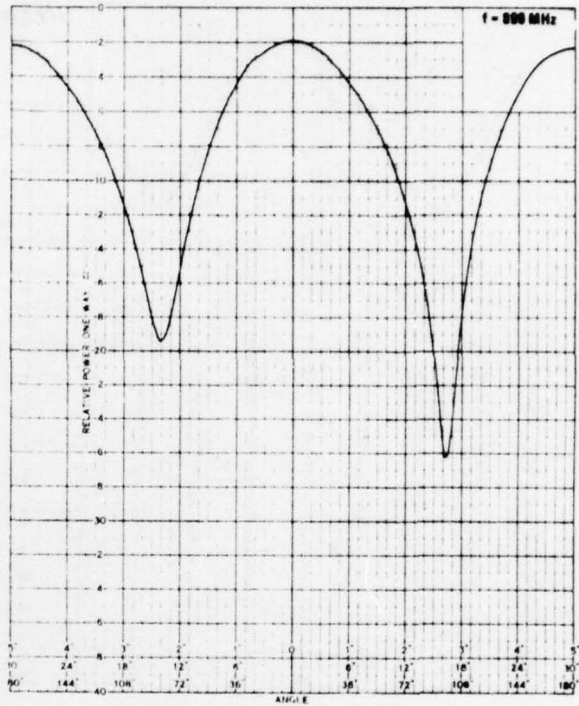
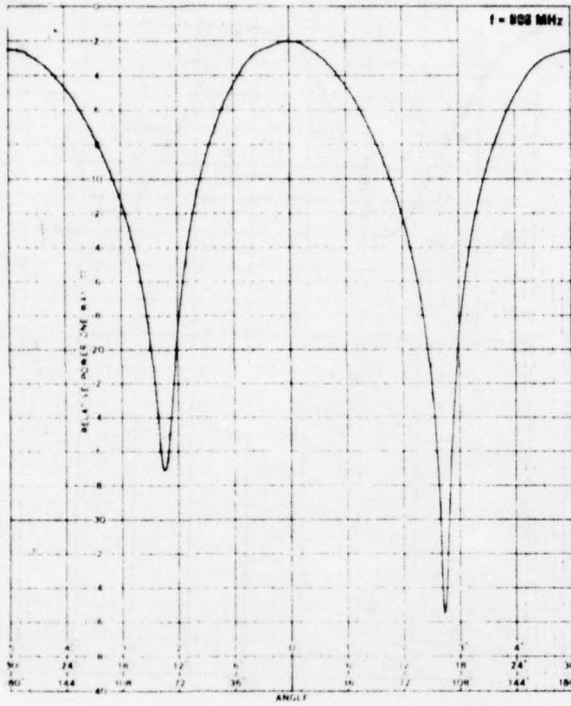

Figure 44. Dipole Patterns in Shielded Enclosure With Hooded Antenna, 898-901 M.

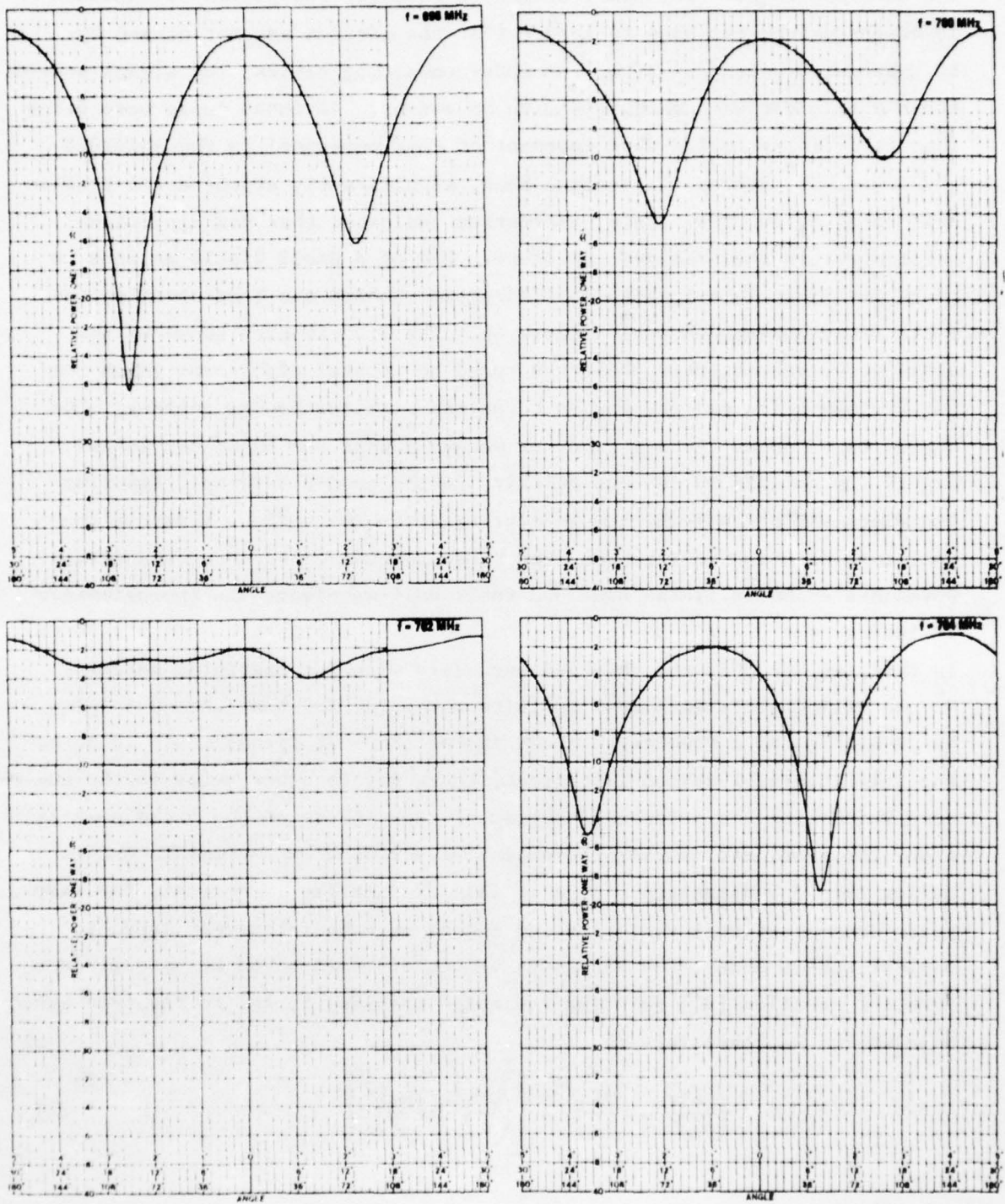

Figure 45. Dipole Pattern Variations For 8-1/2 Inch Hooded Antenna in Shielded Enclosure, 698-704 MHz.

the shielded enclosure. Next, absorbing material was placed at various locations around the hood to insure that the problem was not caused by an unbalanced antenna. Also, the interconnecting cables, the signal source, and the receiver were exchanged with no effect. As these tests were being conducted, it was noted that movement of test personnel in the shielded enclosure, but behind the antenna hood, significantly effected the peak-to-null ratio at 702 MHz. This observation indicated that standing waves existed within the shielded enclosure. Use of a small dipole antenna to probe the field in a longitudinal direction behind the hood revealed the field distributions shown in Figure 46. The distribution shown by the solid curve was observed while the tuned horizontal dipole for which the pattern was being plotted was on boresight with the hooded antenna. The dotted curve shows the distribution measured when the tuned horizontal dipole was rotated 90 degrees relative to the hooded antenna. Ignoring the minor variations--which were attributed to the various items in the enclosure such as the antennas, the antenna mounts, etc.--the standing waves are essentially the same and their half-wavelength is approximately 38 inches, i.e., $\lambda/2 = 38$ inches. One possible explanation of this anomaly is that, at 702 MHz, the shielded enclosure with the absorbing material on one wall appears as a semi-infinite waveguide and that the enclosure has a high Q for a wavelength of 38 inches ($\lambda_g = 38$ inches). It is noted that, if this explanation is correct, there may be other modes in the enclosure which were not detected (because of such things as the probe polarization, location, etc) during the extensive series of measurements made during this investigation. Also if this explanation is correct, the waveguide cross-sectional variations (m and n) must be relatively large to support such a mode. The necessary values of m and n can be determined from the equation [31] relating the guide wavelength, λ_g , to the free space wavelength, λ_0 , that is,

$$\left(\frac{2\pi}{\lambda_g}\right)^2 = \left(\frac{2\pi}{\lambda_0}\right)^2 - \left[\left(\frac{m\pi}{a}\right)^2 + \left(\frac{n\pi}{b}\right)^2\right] \quad (8)$$

Assuming

$$\frac{\lambda_g}{2} = 38 \text{ in.} = 96.5 \text{ cm,}$$

$$\text{then } \lambda_g = 1.93 \text{ m}$$

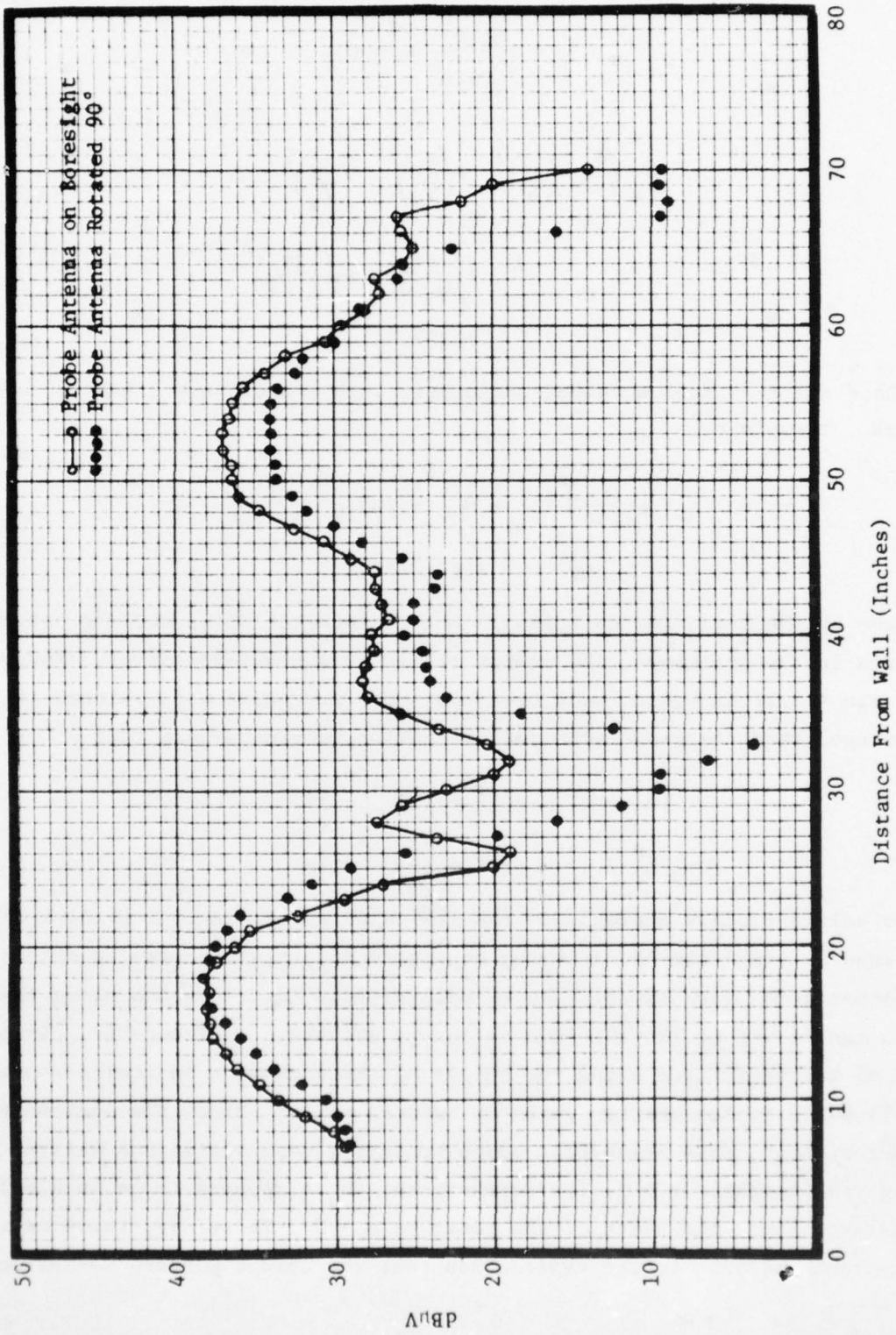

Figure 46. Standing Waves Along Longitudinal Axis of Shielded Enclosure.

and since

$$\lambda_o = \frac{c}{f} = \frac{3 \times 10^8}{702 \times 10^6} = 0.43 \text{m},$$

then

$$\begin{aligned} \left(\frac{m\pi}{a}\right)^2 + \left(\frac{n\pi}{b}\right)^2 &= \left(\frac{2\pi}{\lambda_o}\right)^2 - \left(\frac{2\pi}{\lambda_g}\right)^2 \\ &= \left(\frac{2\pi}{0.43}\right)^2 - \left(\frac{2\pi}{1.93}\right)^2 \\ &= 205.6 \end{aligned}$$

In the 8 x 8 x 20 foot shielded enclosure, both a and b are 8 feet or 2.44 meters. Therefore,

$$\begin{aligned} \left(\frac{\pi}{2.44}\right)^2 (m^2 + n^2) &= 205.6, \\ \text{or } m^2 + n^2 &\approx 124. \end{aligned}$$

Because of the small inaccuracies in the measurement of λ_g and the perturbations in the enclosure, the number 124 is an approximate value. However, if a $m, n = 0, 11$ waveguide mode or a $m, n = 8, 8$ waveguide mode existed in the enclosure, then the cross-sectional variations would be such that

$$\begin{aligned} m^2 + n^2 &= (0)^2 + (11)^2 = 121, \\ \text{or } m^2 + n^2 &= (8)^2 + (8)^2 = 128. \end{aligned}$$

These values closely approximate the 124 value above. Again, a short dipole was used to probe the field in the enclosure and, thus, determine actual cross-sectional variations. The resulting field distributions along the width and height of the shielded enclosure are shown in Figure 47. Inspection of the variations along the height of the enclosure indicates approximately 8-1/2 inches between peaks or between nulls. Since the enclosure is 8-feet high, this means that approximately eleven variations existed along the height, or $n = 11$. Furthermore, there appears to be no distinct variations along the width of the room, or $m = 0$. Therefore, these measurements lend credence to the explanation that the abrupt pattern variations

AD-A033 292

GEORGIA INST OF TECH ATLANTA ENGINEERING EXPERIMENT --ETC F/G 20/14
ELECTROMAGNETIC COMPATIBILITY RATIONALE REPORT: RADIATED TEST R--ETC(U)
APR 76 J C TOLER, J A WOODY

UNCLASSIFIED

FAA/RD-76-70

DOT-FA74WA-3372

NL

2 of 3
AD
A033292



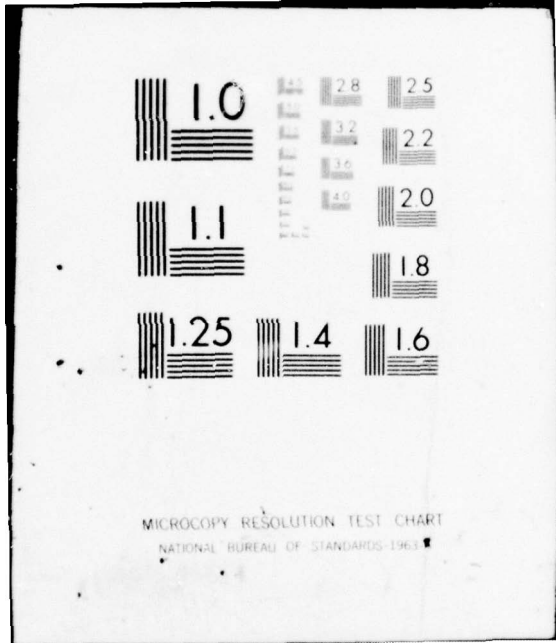

MICROCOPY RESOLUTION TEST CHART
NATIONAL BUREAU OF STANDARDS-1963-A

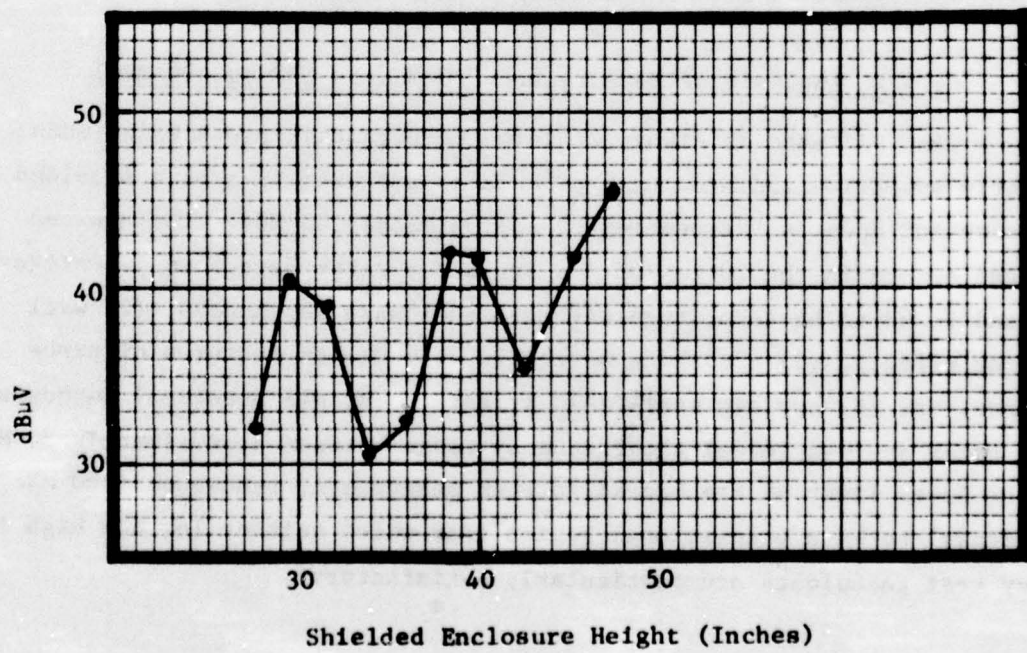
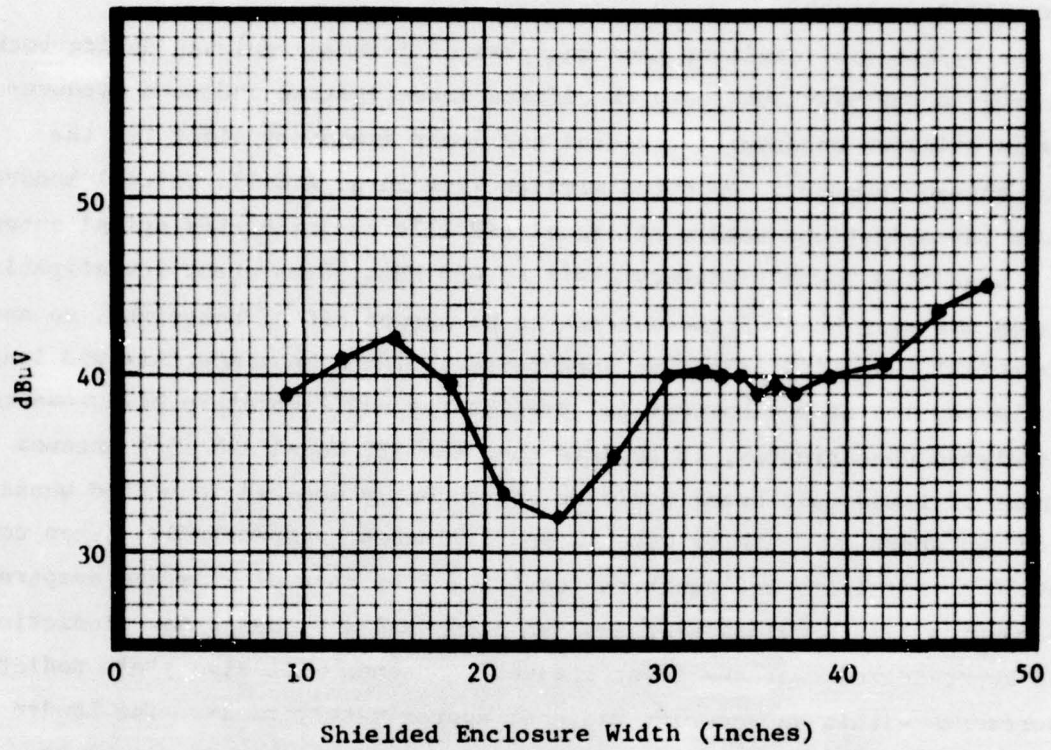

Figure 47. Shielded Enclosure Field Distributions.

at 702 MHz were caused by the existence of a $m,n = 0,11$ waveguide mode in the shielded enclosure.

The hypothesis resulting from analyses of data accumulated during both this program and previous research efforts investigating radiated measurements in shielded enclosures concerns the lower frequency limit for the hooded antenna concept. As noted earlier (see Para. 4.4.3), initial hooded antenna investigations used a AEL Model ASN 117A cavity-backed spiral antenna with a specified lower frequency limit of 400 MHz. Subsequent investigations revealed the main beam of the antenna to be skewed off of boresight, so another antenna (AEL Model ASN 113A) was used to establish a hood aperture and length. When the results of the theoretical predictions and laboratory measurements are analyzed concurrently, it appears that the AEL Model ASN 117A antenna (without a skewed main beam) could be conveniently mounted in a hood whose length and aperture diameter were 12 and 24 inches, respectively. When correlation coefficients and patterns resulting from this program are compared with results from previous programs and then used as a basis for predictions, it is hypothesized that the lower frequency antenna will also yield radiated measurements within an accuracy range of approximately ± 2 dB. The hooded antenna concept would then be satisfactory for radiated measurements in shielded enclosures down to a frequency of 400 MHz.

4.4.4 Analysis of Measurement Procedures (30 to 400 MHz)

As indicated in Figure 2, large measurement errors exist when currently specified radiated test procedures are used in a bare shielded enclosure and down to frequencies of approximately 30 MHz. The sources of these errors in the 20 to 200 MHz frequency range have been investigated [32] and found to be associated with (1) enclosure resonances, (2) wall coupling effects, (3) absorbing materials, (4) design features of probe antennas, and (6) certain near-field effects. For all practical purposes, these error sources reveal the frequency range between approximately 30 MHz and the lower limit of the hooded antenna measurement procedure (400 MHz for this study) to be a transitional region over which neither low nor high frequency test techniques are particularly satisfactory.

Although earlier analyses (see Para. 4.4.1) had concluded that radiated measurements were necessary over the entire 14 kHz to 10 GHz frequency range, the difficulty of accurate tests in the 30 to 400 MHz frequency range caused this decision to be reviewed. In the review, it was noted that FAA equipments significant in number and critical in function operate at assigned frequencies throughout the VHF (30 to 300 MHz) and lower UHF (300 to 400 MHz) range. Typical of these equipments are the following:

- Marker Beacons 73 MHz
- Localizer. 108-112 MHz
- VOR. 110 MHz
- Remote Transmitter/Receiver Sites. 118-380 MHz
- Compass. 200-400 MHz
- Glide Slope. 328-336 MHz

In addition to these equipments, which are characterized by discrete frequency operation, lengthy experience in EMC measurements led to the conclusion that broadband signals of concern will also exist between 30 and 400 MHz. Therefore, from the point-of-view of both discrete frequency and broadband signals and for both emission and susceptibility characteristics, it was again concluded that radiated tests over the 30 to 400 MHz frequency range were essential.

As was the approach in the 400 MHz to 10 GHz frequency range, brief considerations were given to the possibility of either open-field or shielded anechoic chamber measurement procedures. An open-field test location, if sufficiently large and free of reflecting structures, would obviously eliminate low frequency coupling and high frequency multipath problems. However, the cost associated with providing a suitable open-field area and the scheduling problems caused by inclimate weather conditions rendered this solution unattractive. A similar conclusion was reached regarding the anechoic chamber test location. Practical absorbing materials that provide appreciable energy absorption at 30 MHz would be prohibitively large (8.2 feet) since their length must correspond to approximately one quarter wavelength. Obviously, materials of this length could not be used on the six walls of any reasonably sized shielded enclosure. Other absorbing materials in the form of ferrite tiles approximately one inch high are advertised as providing

more than -15 dB of energy absorption down to 50 MHz; however, laboratory evaluations [33] of these materials at Georgia Tech have shown this to be an overly optimistic statement of absorbency.

An extensive review and analysis effort was then undertaken to determine the suitability of measurement procedures published in the available literature. This effort revealed one approach [34] that involved continually perturbing the field in the shielded enclosure while the radiated test was in process. During the test, the field level was monitored at numerous points throughout the enclosure. In theory, the perturbation techniques are an electrical analog of techniques developed for determining the acoustical power level emitted by noise sources in reverberation chambers. For radiated EME and EMS tests, this technique would yield data in units of total radiated power, which must then be related to field strength levels under open-field conditions. Because of the complexity of the test, the methods available for perturbing the field, and the lack of data correlating measured results with open-field signal levels, this measurement procedure did not appear satisfactory at this time.

A second measurement procedure noted in the literature analysis was one that reduced radiated measurement errors by coating the inside walls of the shielded enclosure with a lossy material [35]. This material reduced the Q of the enclosure and thereby reduced measurement errors by more than 20 dB both above the lowest resonance of the enclosure, where resonance coupling predominates, and below the lowest resonance, where wall coupling predominates. The lossy material was a mixture of graphite and spackling compound, and the investigation showed that its surface texture, conductivity, and thickness were not critical parameters in reducing resonance coupling. The graphite-to-spackling compound mix ratio was 1.0:1.1 by weight and the resulting conductivity was 1.0 mho per meter. This same program investigated a series of dielectrically-loaded and end-loaded short dipole antennas for reducing still further the radiated measurement error. It was concluded that the best probe performance was obtained by utilizing a set of three end-loaded dipoles to cover the 20 to 200 MHz frequency range. However, the evaluation and analysis of these probes were limited and there was no opportunity to optimize the lossy wall material or the end-loaded dipoles.

In fact, the lossy wall material and end-loaded dipole probes, even though promising, to date have been evaluated only in a model of a full-sized shielded enclosure and under simulated measurement conditions.

4.4.5 Analysis of Measurement Procedures (14 kHz to 30 MHz)

Over this frequency range, the size of typical shielded enclosures relative to a wavelength is such that signal reflection problems associated with the 400 MHz to 10 GHz frequency range are negligible. Further, signal nulls within the enclosure caused by coupling between the monopole antenna and the enclosure walls are not significant. Therefore, since neither reflection or standing wave problems are major, coupling between a source and receptor in a shielded enclosure and an anechoic chamber can be closely correlated. This, of course, assumes that identical test configurations are used during each series of measurements. That this coupling is closely correlated over the 1 to 30 MHz frequency range is shown in Figure 2.

In view of these considerations, the analysis concluded that repeatable radiated measurements could be made in a shielded enclosure over the 14 kHz to 30 MHz frequency range. The measurement configuration would utilize the monopole antenna, and, when carefully controlled, would yield data closely correlatable with that measured in an anechoic chamber. However, exactly what the resulting data means or represents, insofar as "radiated" equipment characteristics are concerned, is rather vague. This vagueness is attributable primarily to two factors: (1) the location of the test antenna in the near field of the test item and (2) the unbalanced nature of the monopole antenna. Complexity of a radiated wave in its near-field region is recognized, and measurements made within this region must normally be used for relative, rather than absolute, purposes. The unbalanced output of the monopole antenna results in the interconnecting cable to the test equipment being responsive to the radiated environment. Position and length of this cable then influence the level indicated by the test equipment. Consequently, although careful control of the test configuration permits repeatable measurements to be made, it becomes improbable that an accurate measurement can be made. Therefore, valid interpretation and utilization of the measurement results in analyzing potential system level EMC problems will be difficult.

4.5 Test Method RS02, Magnetic Induction Fields

It is the purpose of this test method to determine the susceptibility of Class I equipments (receivers, transmitters, counters, oscilloscopes, signal generators, computers, power supplies, etc.) and their non-power related cables to magnetic induction fields generated by steady state and transient currents. As such, the following four tests are required:

- (a) Equipment case susceptibility to steady state magnetic fields
- (b) Equipment case susceptibility to transient magnetic fields
- (c) Cable susceptibility to steady state magnetic fields
- (d) Cable susceptibility to transient magnetic fields

The magnetic field frequency during exposure to steady state currents is to be that of the power source at the equipment's operational installation site; therefore, this frequency will be 60 Hz for FAA equipments. The overall test procedure specifies that equipments and cables be individually exposed to magnetic induction fields generated by test currents circulating through wires wrapped spirally around them. Susceptibility performance of the equipments is monitored during exposure of the case and cable to the magnetic field.

Several modifications to the basic test method and its applicability have been incorporated by the various Notices to MIL-STD-461A and MIL-STD-462. For example, the Army (Notice 3, MIL-STD-462) has deleted all requirements for the steady state field exposure of equipment cases and has both changed the method of transient calibration and reduced the transient field amplitude by a factor of one-half. Also, Army requirements for the test method were dropped for all power supplies and test equipment (Notice 4, MIL-STD-461A). The Air Force (Notice 3, MIL-STD-461A) required that support subsystems and equipments have the test procedure imposed only in those instances in which systems analysis revealed a necessity for magnetic induction field testing. It is thought that MIL-STD-462B, when published, will further change the amplitude of the transient magnetic fields to which equipment cases and cables must be exposed [36].

The test procedure specified by MIL-STD-462 has at least one major point of confusion. Two current-carrying wires are required to be taped to each wire bundle in the test set-up. Equipment performance is monitored

for susceptibility while steady state and transient currents are circulated through one of these current-carrying wires at a time. The confusion arises because the specified test configurations (Figures RS02-1 and RS02-2) show only one current-carrying wire; therefore, the location and routing for the second wire is unknown. Not directly related to confusion with the test configuration but a matter of concern is the fact that the purpose served by the second current-carrying wire is also unknown. It is noted that the Army deleted requirements for this second wire when the entire test procedure was rewritten (Notice 3, MIL-STD-462).

During interviews at and surveys of FAA facilities, specific emphasis was placed on determining the extent to which magnetic induction fields were a source of interference problems. This emphasis was the result of concern regarding the ability to technically justify recommendations that FAA equipments be tested for magnetic induction susceptibility. No incidence of such susceptibility was reported to have occurred by any of the technical and operational personnel interviewed. Additionally, surveys conducted in a cross-section of FAA facilities failed to reveal magnetic induction fields to be the source of any identifiable interference problems. These surveys included an extended observation of typical operational activity in the various facilities.

Information available regarding the electromagnetic environment in representative FAA facilities provided some useful data regarding the need for magnetic induction field tests; however, none of this data included a measure of the ambient levels of 60 Hz radiated signals. At the Los Angeles ARTCC, the steady state 60 Hz magnetic field caused interference in the Plan Display when the test wire was wrapped around the equipment case. This interference was in the form of "display displacement in the TV mode and pattern character wobble in the CDC mode" [37]. During the tests in which the test wire was wrapped around cables in the test set-up, the 60 Hz magnetic field "caused slight displacement in the CDC mode, none in the TV mode" [38]. Several incidences were reported in which transient magnetic fields interfered with equipment operation. In most instances, the transient amplitudes were 50 volts and above, and the interference was in the form of pattern jitter, pattern wobble, display distortion, illegal entry, pattern error indications, lines on displays, etc. In one incidence, however, a transient

amplitude of 7 volts was reported to cause horizontal lines on an unidentified display. Much the same type of interference was recorded during magnetic induction field tests conducted in the New York ARTCC [39]; however, the number of reported incidences was significantly less than at the Los Angeles ARTCC. In the Oakland ARTCC, only one incidence of magnetic field susceptibility was reported out of a total of 68 tests. This incidence was one in which transients with amplitudes greater than 55 volts and pulse rates of six to ten pulses per second "produced errors on tape which prevented readout" [40] when induced into the tape drive wire bundle. When data from the three air route traffic control centers are reviewed, it is seen that approximately 15 cases of magnetic field susceptibility were recorded during performance of some 225 tests.

It is essential that the above data measured in air route traffic control centers be considered in terms of the technical adequacy of test procedures specified by Test Method RS02. Regarding wire bundle test procedures, two different susceptibility modes, i.e., common mode and differential mode, can exist. Common mode susceptibility will exist because of the closed loop formed by the wire bundle under test and the ground plane or ground conductor associated with the wire bundle interconnection. Interference currents flowing longitudinally in the wire bundle will result from magnetic flux intercepting this loop; however, their magnitude will be unknown because the test procedure does not define the loop configuration. Consequently, whether or not an equipment complies with the MIL-STD-461A limits for Test Method RS02 is significantly influenced, either intentionally or unintentionally, by the test configuration used. Since this configuration is unspecified (insofar as loop area formed by the wire bundle, interconnected equipments and ground return path is concerned), there will be little data repeatability from tests conducted by different test personnel and/or at different test locations. Differential mode susceptibility, if it exists, will also suffer from a serious lack of data repeatability because the highly critical spacing between a test wire and wire bundle is unspecified. However, there is little concern with data repeatability because field cancellation effects will preclude most differential mode susceptibility. These effects result from the fact that the test wire wrapping configuration

will induce canceling voltage components in adjacent sections of the wire bundle; consequently, differential mode susceptibility will be almost non-existent in the wire bundle tests.

4.6 Test Method RE03, Radiated Spurious and Harmonic Emissions, 10 kHz to 40 GHz

This test method is applicable only to transmitters and would normally be replaced by a conducted measurement procedure (Test Method CE06). However, at times there are measurement conditions associated with transmitters that render a conducted test method impractical. Typical of these conditions are (1) very high output power levels, (2) operating frequencies high enough that waveguide rather than coaxial cable must be used, and (3) design features in which the antenna and transmitter are inseparable. It is for conditions such as these that this test method is intended.

The measurement procedures required by MIL-STD-462 are clearly applicable only when the direct coupled techniques of Test Method CE06 cannot be used. A detailed listing of transmitter operating frequencies versus the frequency range of the test is provided. Either an EMI meter or a spectrum analyzer is used as the basic measurement instrument, depending on whether the test frequency is below (EMI meter) or above (analyzer) 1.0 GHz. No precautions are provided regarding the lower power levels that are tolerable at the inputs to these instruments. Also, additional precautions regarding the possibility of spurious response generation within the test instrument would be desirable. Test procedures that are cumbersome to follow--but essential if an accurate test is to be conducted--are provided for the 1.0 to 40 GHz frequency range. However, no comparable procedures for frequencies below 1.0 GHz are provided. Further, procedures are not adequately provided for test conditions in which a transmitter operates at or below 1.0 GHz where waveguide interconnections are generally applicable.

Changes to these requirements as a result of notices are highly varied. For example, the Air Force (Notice 2, MIL-STD-462) agrees with the need for the test and stipulates that it will be conducted only when the conducted procedures cannot be used and when approval is obtained from the procuring activity. On the other hand, the Army (Notice 3, MIL-STD-462) has completely

rewritten the test method, retaining essentially all of its basic features but incorporating numerous changes. These changes are individually minor, but collectively they yield a test method considerably improved in its technical requirements. For example, the Army notice adds a test procedure for the 10 kHz to 1.0 GHz frequency range and recognizes other measurement situations likely to arise when testing transmitters.

Interviews with personnel at the various FAA facilities revealed the primary cause of reported interference problems to be the "environment." At these facilities, the "environment" is a complex summation of radiated signals from a wide variety of ground-based and airborne sources. It is therefore understandable that interference problems related to the "environment" would exist. Further, the surveys of FAA equipments revealed the expected fact that transmitters and receivers are extensively used. These equipments are often colocated in the same room or equipment rack; again, the opportunity for interference is maximized.

4.7 Test Method RS03, Radiated Susceptibility, 14 kHz to 10 GHz, Electric Field

This test method is intended to be the susceptibility counterpart for the emission measurements specified in Test Method RE02. For the 30 MHz to 10 GHz frequency range, this intent is realized; however, below 30 MHz, gross errors in this test method exist because of the required low frequency antenna. Above 30 MHz, all of the Test Method RE02 investigations concerned with accurate and reliable radiated emission measurements in shielded enclosures are equally applicable to this test method. Because of their length, a description of these investigations is not repeated; however, in summary, they resulted in (1) the development of hooded antennas for shielded enclosure measurements over the 400 MHz to 10 GHz frequency range, (2) an analysis of field perturbation and lossy material wall coverings as possible means by which accurate measurements can be made over the 30 to 400 MHz frequency range, and (3) no change in the present MIL-STD-461A and MIL-STD-462 requirements over the 14 kHz to 30 MHz frequency range.

Below 30 MHz, both Test Method RE02 and this test method require the use of a 41 inch monopole antenna with suitable tuning networks. In this test method, the monopole antenna is required to develop a susceptibility

environment of 1.0 volt per meter at a distance of one meter. At the lower end of the 14 kHz to 30 MHz frequency range, the antenna is highly inefficient and several watts of power must be delivered to the tuning networks if a 1.0 volt per meter field is to be realized. However, at these power levels, the tuning inductors saturate and overheating with eventual burnout is a definite possibility. This situation is made even worse for the Air Force because of their change to the basic procedure (Notice 3, MIL-STD-461A) which requires a 10 volt per meter susceptibility environment for "subsystems and equipments to be installed in an aircraft or other metallic structure."

Efforts were made by the Army (Notice 3, MIL-STD-426) to correct this situation by prohibiting use of the 41 inch monopole antenna and replacing it by either a long wire or parallel strip line antenna. This necessitated the generation of two entirely new test configurations and procedures. For the long wire antenna configuration, a horizontal wire was located at the longitudinal center of the shielded enclosure at a distance from the ceiling equal to approximately one-fourth the enclosure height. The wire is held taut on insulators and the load-end is terminated with a non-inductive resistance equal to the characteristic impedance. A concentric feeder line extends from the source end of the wire to the signal generator output. Procedural details are provided by which the wire antenna and concentric feeder line are to be terminated and a calibration procedure for relating voltage at a point on the wire to volts per meter is shown. In the case of the parallel strip line antenna, aluminum plates spaced 18 inches apart are used to form an area within which the susceptibility environment is generated. This 18 inch separation distance introduces a definite restriction on the test item size (test items must be no closer than four inches to the upper plate), but this restriction is necessary in order to comply with applicable wavelength versus separation distance requirements. All test items are tested at orientations in which openings for power lines, shafts, meters, ventilation, etc. are positioned toward the top plate. Therefore, a test item with openings on three different sides could be no larger than 14 inches (18-4 inches) on a side.

The results of interviews with FAA personnel and surveys of FAA facilities as presented for Test Method RE02 are equally applicable to this test method.

4.8 Test Method (T) RE04, Radiated Emissions, 20 Hz to 40 kHz,
Magnetic Field

As indicated by the (T) symbol associated with the RE04 number, this test method is tentative and intended for "Trial Use" only (see Note (1) to Table II, MIL-STD-461A). The test method purpose is identical to that stated for Test Method RE01, except for the fact that Test Method RE01 is applicable to "electrical and electromechanical equipments" while this test method is applicable to "electronic, electrical, and electromechanical equipments." In both test methods, the intent to measure radiated magnetic fields emitted by equipments plus their associated cabling and interconnected wiring (including power, pulse, IF, video, antenna transmission and power cables). In this test method, the applicable frequency range is 20 Hz to 50 kHz, while the Test Method RE01 frequency range is 30 Hz to 30 kHz. From the point-of-view of test configuration and procedure, the test methods are also identical in their essential requirements. The only differences of any consequence are related to the fact that Test Method RE01 specifies use of an EMI meter as the basic test instrument while this test method specifies a magnetic field sensor and electronics.

Regarding the need for FAA equipments to comply with this test method, the comments made for Test Method RE01 (Para. 4.2) are directly applicable. In summary, these comments noted that (1) no interference problems traceable to low frequency magnetic fields were reported by personnel at FAA facilities, (2) no evidence of interference problems caused by low frequency magnetic fields was found during surveys of a variety of FAA facilities, (3) measurements made in ARTCC facilities revealed no low frequency magnetic field problems, and (4) the limited amount of published information regarding the rationale for MIL-STD-461A requirements stated that low frequency magnetic field tests were applicable only to equipments used on submarines.

4.9 Test Method (T) RS04, Radiated Susceptibility, 14 kHz to 30 MHz

As described in Paragraph 4.8, the (T) symbol indicates that this test method is tentative and intended for "Trial Use" only. This test method's purpose is to determine the susceptibility of all Class I equipments to "radiated fields of specified spectral content and intensity." An electric field

with an intensity corresponding to the applicable limits is produced in a parallel plate line. The test item is then placed between the parallel plates and its operation monitored for malfunction or degradation of performance. The test item must be oriented with the front face directed out toward the side of the line, with the front face directed along the length of the line, and with the points of maximum radiation, as determined by probing the faces of the test item, directed toward the upper plate. Also, the test item must be oriented such that faces with openings for power leads, shafts, ventilation, etc. are directed toward the upper plate.

The most important advantage of the parallel plate line is that relatively high (≈ 1 V/m) field intensities for susceptibility testing can be produced very efficiently over a wide (14 kHz to 30 MHz) frequency range. The major limitation of the test method is that the test item must have a size compatible with the dimensions of the parallel plate arrangement. These dimensions (18 inch height), the requirement that the test item be four inches or more from the upper plate, and the various orientations required will in general limit all three dimensions of the test item to approximately 14 inches.

4.10 Test Method RE05, Radiated Emission, Broadband, 150 kHz to 1000 MHz

The purpose of this test method is to measure broadband radiated emissions from vehicles and engine-driven equipment, including the electrical equipment, subassemblies, parts and accessories installed thereon. The equipments for which this test method is intended and the associated test frequency ranges are tactical vehicles from 150 kHz to 1 GHz, engine generators from 150 kHz to 1 GHz, and special-purpose vehicles and engine-driven equipment from 150 kHz to 400 MHz. The measuring antennas are oriented vertically, except to measure radiation from top openings over engine compartments, and then they are located "at as many positions around the test sample as are necessary to obtain an effective test of the maximum radiation." They are located horizontally one meter from the outer perimeter of the test sample and vertically one-to-two meters, as necessary for maximum pickup, above the earth. For measuring radiation from top openings over engine compartments, the test antennas are located directly over the compartment openings. In each position of the measurement antenna, the emission level is recorded as a function of frequency over the 150 kHz to 1 GHz frequency range.

There are two basic modifications to this test method as a result of notices. The Army (Notice 3, MIL-STD-462) changes the spacing between the item under test and the test antenna from one to two meters, and deletes the applicability to engine generators. These generators are subsequently included under the test requirements of Test Method RE02 (Notice 4, MIL-STD-461A). It is reported that in MIL-STD-462B, this test method will be identified as Test Method UM03 and the upper test frequency will be changed from 1000 MHz to 400 MHz [41]. This is a desirable change since past experience has shown that broadband signal levels decay significantly above approximately 100 MHz and few, if any, such signals exist above 400 MHz.

A deficiency of the test method as presently stated is that the test antenna must be located "at as many positions around the test sample as are necessary to obtain an effective test of maximum radiation." This statement is vague and presumably requires receiver frequency scanning while simultaneously (1) moving a bulky antenna continuously around the test sample and (2) maintaining the antenna at a one meter (or two meter pursuant MIL-STD-462, Notice 3) fixed distance from the test sample. It would appear more logical to probe the test sample as described in Paragraph 4.2.4.1 of MIL-STD-462 and required by Test Method RE02. Then actual measurements with the specified antennas and with frequency scanning could be conducted at the positions of maximum radiation.

In determining the necessity for requiring this test method, careful consideration was given to the results of surveys at FAA facilities and to interviews with FAA personnel at these facilities. The surveys indicated that numerous FAA facilities have one or more engine generators and also may have numerous FAA-controlled motor-driven vehicles. The generators are likely sources of both broadband and narrowband signals due to commutator arcing and rate, respectively. Broadband signals are likely from the ignition systems on motor-driven vehicles. Considered with these likely emission sources were the interview reports of "environmental" interference.

4.11 Test Method RE06, Radiated Emission, 14 kHz to 1 GHz, Overhead Power Lines

The stated purpose of this test method is to measure radiated emissions over the 14 kHz to 1 GHz frequency range from overhead power lines

operating at voltages from zero to 1000 kV. Power lines to FAA facilities are in general owned, operated, and maintained by a utilities company and, hence, FAA has limited control over their electromagnetic characteristics. There are, however, situations in which power source performance criteria can be established by the FAA and imposed on a utility company when a new site is being constructed. Further, when a new power line is constructed in the vicinity of an operational FAA facility, the utility company can be held responsible for any harmful interference that results. As is evident, these situations do not fit the conventional electronic equipment procurement request in which EMC standards represent one of perhaps many different performance requirements. Because of this, it was initially agreed that Test Method RE06 was not applicable to these investigations. After preparation and submittal of the draft version of this Final Report, this agreement was changed and inclusion of Test Method RE06 was requested. In order to accommodate this within tractable limits on the effort necessary, the power line radiated emission requirements as they appear in MIL-STD-461A and MIL-STD-462 are added as Appendix A.

5. RECOMMENDATIONS

5.1 Overview

In the previous paragraphs (Section 4), a description was provided of the basic requirements in each of the MIL-STD-461A and MIL-STD-462 test methods. Additionally, results of the analysis conducted to determine the rationale for each test method were presented. In this Section, these descriptions and results are condensed to a format that permits specific recommendations to be made regarding the applicability of individual test methods to the needs of FAA equipments. These recommendations are first presented in terms of the test methods that should be adopted, then the test configurations and procedures that should be used, and finally the limits to be imposed on equipment electromagnetic performance.

5.2 Test Method Recommendations

5.2.1 Test Method RE01, Radiated Emissions, 30 Hz to 30 kHz, Magnetic Field

It is recommended that FAA equipments not be required to comply with any magnetic field emission tests in the 30 Hz to 30 kHz frequency range. This recommendation is consistent with earlier actions adopted for Air Force and Army equipments and is based primarily on the following rationale summary:

1. Radiated magnetic field tests in ARTCC facilities at Los Angeles, Oakland, and New York concluded that magnetic field emissions presented no problem.
2. Surveys of equipments and their performance characteristics at the Atlanta ARTCC led to an identical conclusion. Further, this same conclusion was reached after surveying equipments at other FAA facilities (FSS, ATCT, RAGC sites, terminals, etc.).
3. The only available sources of information which describe the original basis for this test method state that it is intended for Navy application to submarine equipments.

4. As currently specified, the test procedures have obvious errors, are difficult to interpret and require the simultaneous performance of tasks that involve tuning a sensitive receiver, sequencing an equipment through its operational modes and probing equipment surfaces with a sensor.

5.2.2 Test Method RS01, Radiated Susceptibility, 30 Hz to 30 kHz, Magnetic Field

It is recommended that FAA equipments not be required to comply with any magnetic field susceptibility tests in the 30 Hz to 30 kHz frequency range. Earlier reviews of this test method by the Air Force reached the same conclusion. Although the Army retained the test method, they limited its applicability to only airborne surveillance, compass and data annotation equipments. The primary rationale upon which this recommendation is based is summarized as follows:

1. This test method is the susceptibility counterpart of the emission tests required by Test Method RE01. As such, data obtained while performing this test should be compared with counterpart data from the tests required by Test Method RE01. However, it has previously been recommended that Test Method RE01 applicability to FAA equipments be deleted.
2. Surveys of equipments and interviews with personnel in a cross-section of FAA facilities revealed no obvious need for this test.
3. As was the case in the analysis of Test Method RE01, this test method specifies procedures for which no technical justification was available.
4. The only available documentation regarding the original rationale for this test method was concerned with Navy application to submarine equipments.

5.2.3 Test Method RE02, Radiated Emission, 14 kHz to 10 GHz,
Electric Field

It is recommended that Class I, II, and III FAA equipments be required to comply with narrowband emission tests over a 14 kHz to 10 GHz frequency range and broadband emission tests over a 14 kHz to 400 MHz frequency range. Details of the procedures, configurations and limits recommended for these tests are presented in subsequent paragraphs. The primary rationale upon which this recommendation is based is summarized as follows:

1. Without exception and despite a lack of any published rationale, the Army, Air Force and Navy each require an electric field emissions test for their electronic equipments.
2. Surveys of equipments in FAA facilities revealed operational modes, coupling paths, emission levels, and sensitivities which indicated that electric field radiated emissions must be controlled.
3. Interviews of FAA personnel with equipment operation and maintenance responsibilities revealed cases of "environmental" interference. Further probing indicated that this interference was most probably the result of electric field coupling into sensitive circuits.
4. Extensive experience in performing emission tests on a wide variety of military and consumer electronic devices has shown that narrowband and broadband emissions up to frequencies of 10 GHz and 400 MHz, respectively, are prevalent. If compatibility at the system level is to be achieved in a cost-effective manner, these emissions must be controlled.

5.2.4 Test Method RS02, Radiated Susceptibility, Magnetic Induction Fields

It is recommended that provisions of this test method not be imposed on FAA equipments. The basic consideration underlying this recommendation was the fact that the equipments observed during FAA surveys were designed such that they would not be expected to either emit or respond to induced magnetic fields. The equipments did not require large currents in their operation, and cable loops into which currents would be induced were relatively small in size. This conclusion is supported by the previously mentioned (see Para. 4.5) measurement series in which only approximately 15 cases of magnetic field susceptibility were observed during performance of 225 tests. Few, if any, of these susceptibility cases caused more than a brief annoyance to facility operation.

5.2.5 Test Method RE03, Spurious and Harmonic Emissions, 10 kHz to 40 GHz

It is recommended that Class I FAA transmitters be required to comply with requirements of this test method as modified by Notice 3 to MIL-STD-462, when:

1. the transmitter output is greater than five kilowatts average power, and/or
2. the fundamental frequency is above 1.0 GHz, and/or
3. the transmitter and its antenna are designed to be inseparable.

It is also recommended that the 10 kHz lower frequency limit be changed to 14 kHz to eliminate the need for another complement of test instruments and antennas.

This recommendation is based primarily on the fact that (1) transmitters with reasonably high output levels are prevalent at some FAA facilities, (2) conducted measurements under any of the above conditions would be difficult if not impossible to perform, and (3) a majority of the reported interference problems of FAA facilities are described as being caused by the radiated environment.

5.2.6 Test Method RS03, Radiated Susceptibility, 14 kHz to 10 GHz,
Electric Fields

As was noted in Para. 4.7, this test method is intended to be the susceptibility counterpart of Test Method RE02. For the same reasons that Test Method RE02 is recommended, this test method is also recommended for all FAA equipments in Classes I, II, and III; however, this recommendation is applicable only for tests over the 30 MHz to 10 GHz frequency range. It is further recommended that tests specified by this test method for the 14 kHz to 30 MHz frequency range be deleted. Electric field susceptibility tests adequate for this low frequency range are subsequently recommended (see Para. 5.2.8).

5.2.7 Test Method (T) RE04, Radiated Emissions, 20 Hz to 50 kHz,
Magnetic Field

It is recommended that FAA equipments not be required to comply with the provisions of this test method. This recommendation is based on the lack of observed or reported interference problems caused by low frequency magnetic fields and the fact that the test method's intended application is to submarine equipments. An additional consideration is the fact that this test method is an alternative procedure for Test Method RE01, which was not recommended for FAA adoption. The major differences between the test methods lies in the fact that this method's procedures are tailored to a specific test equipment (the Magnetic Field Intensity Meter by Electro-Mechanics Company) undergoing trial evaluation [42].

5.2.8 Test Method (T) RS04, Radiated Susceptibility, 14 kHz to
30 MHz

It is recommended that Class I, II, and III FAA equipments be required to comply with provisions of this test method as modified and presented in Method RS03 of Notice 3 to MIL-STD-462. This will delete tests that propose to use the 41 inch monopole antenna and incorporate the option of using either a long wire antenna or parallel plate line to generate the desired susceptibility environment. In practice, the long wire antenna

method is preferred because (1) limitations imposed on the test item size by wavelength versus separation distance factors are reduced and (2) special test configuration construction is minimized. When the long wire antenna configuration is used, the wire should be located between the two side walls of the shielded enclosure and directly over the ground plane center. Support of the wire can be accommodated by small hooks that attach directly to the enclosure walls. Formulas provided in Notice 3 to MIL-STD-462 plus published information [43] regarding long wire antennas in shielded enclosures should be used in determining terminations, calibration factors, etc. for this antenna configuration.

5.2.9 Test Method RE05, Radiated Emission, Broadband, 150 kHz to 1000 MHz

It is recommended that Class IV engine generators and motor-driven vehicles over which FAA has control be required to comply with requirements of this test method; however, the following two changes should be incorporated: (1) the upper frequency limit should be decreased to 400 MHz and (2) the horizontal distance from the reference point on the antenna to the outer perimeter of the test item should be increased to two meters.

This recommendation is based primarily on the fact that the most often reported EMC problems at FAA facilities were attributable to "environmental" electromagnetic signals. From previous experience, both unsuppressed generators and ignition systems in motor-driven vehicles are known to be prolific sources of undesired broadband signals. Further, generators have been shown to provide appreciable levels of undesired narrowband signal at frequencies corresponding to their commutation rate. Therefore, both of these devices are thoroughly capable of contributing undesired "environmental" signals, and thereby increasing the possibility of interference with equipment functioning. Obviously, this is a situation in which there is a concern with signal emissions, but no corresponding susceptibility concern. It is noted that, if FAA exercised control over motor-driven vehicles (scooters, low vehicles, trucks, etc.) used on the apron area at airports, the provisions of this test method would also be recommended for application. This recommendation would be based on the fact that these vehicles exist in relatively

large numbers and are used at times in close proximity to sensitive electronic equipment.

The recommended decrease in upper frequency limit is based on test experience that indicates broadband signal magnitudes decrease rapidly above approximately 100 MHz. Additionally, mechanical design considerations prevent signals related to commutation rates in FAA generators from being generated above approximately 10 MHz. The recommended change in separation distance between the antenna reference point and the test item perimeter is made to improve measurement accuracy by reducing the test item influence on antenna performance.

5.2.10 Test Method RE06, Radiated Emissions, 14 kHz to 1 GHz, Overhead Power Lines

As noted in Paragraph 4.11, requirements for radiated emissions from overhead power lines were added by the FAA after the draft version of this Final Report was prepared. These requirements are taken directly from MIL-STD-461A and MIL-STD-462 and are presented in Appendix A.

5.3 Test Configuration and Procedure Recommendations

5.3.1 Test Method RE02, Radiated Emissions, 14 kHz to 10 GHz

5.3.1.1 400 MHz to 10 GHz Frequency Range

Over this frequency range, it is recommended that radiated electric field tests be conducted in a shielded enclosure with dimensions no less than 8 x 8 x 12 feet and that hooded antennas be used for both emission and susceptibility measurements. The wall of the shielded enclosure behind the test item should be lined with an absorbing material which provides at least -15 dB reflectivity down to 400 MHz. The antenna hoods should consist of metal cylinders lined on the inside with Emerson and Cuming Type NZ-1 Absorbing Material, or equivalent. In one end of the cylinder should be an absorber-lined metal end plate to which is mounted a circularly polarized cavity-backed antenna with a planar log-spiral element. The opposite end of the cylinder should remain open and, in its final position in the shielded enclosure, this open end will be directed toward the test item. The inside

dimension of the hood from the antenna face to the cylinder opening may be filled with an electromagnetically transparent material (Dow Chemical Corporation Ethafoam[®], for example) to provide both support and protection for the absorbing material and antenna. The number of hoods, hood dimensions, and suitable antennas for this frequency range are given in Table VI. Design features of a representative antenna mounted in its hood are presented in Figure 48. Initial contacts have been made with Dr. Fred Morris, Tensor, Inc., P.O. Box 14843, Austin, TX 78761, phone: 512-873-4900 who indicated an interest in providing quotes on the manufacture of these hooded antennas. In the past, Dr. Morris' company has manufactured conical log-spiral antennas for EME/EMS testing and a type of hooded antenna used for helicopter applications. In Figure 49, a hooded antenna is shown positioned in the recommended shielded enclosure configuration. This configuration involves positioning such that the antenna hood is centered in the vertical cross section of the enclosure. The test item positioner has both azimuth and elevation rotation capabilities to minimize difficulties in probing the various test item faces during radiated tests. The support material for the test item is stacked to a height that centers the test item and hooded

TABLE VI
SUITABLE ANTENNAS FOR USE IN HOODS

Frequency Range (GHz)	Hood Dimensions		Recommended Antenna*		
	Inside Diameter (Inches)	Length (Inches)	Model	Diameter	Depth
6.0 to 10	2.0	1.0	Model ASN 111A	2.0"	1.86"
2.0 to 6.0	4.0	2.0	Model ASN 118A	3.0"	2.17"
1.0 to 2.0	12.0	4.0	Model ASN 116A	7.5"	3.25"
0.4 to 1.0	24.0	12.0	Model ASN 117A	13.25"	5.75"

*Model numbers and dimensions correspond to antennas available from American Electronics Laboratory, Lansdale, PA, 19446. Equivalent antennas are available from other commercial sources.

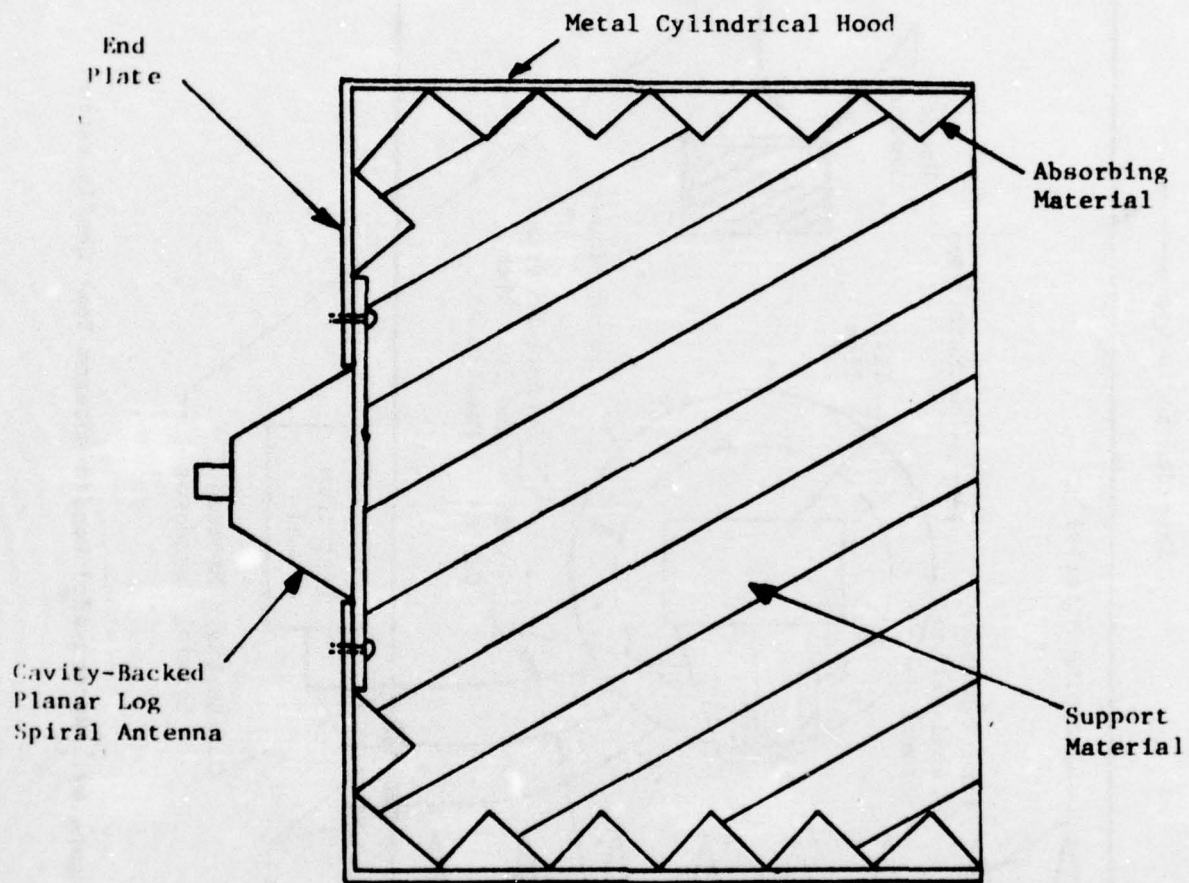

Figure 48. Representative Hooded Antenna Design Features

antenna. Like the antenna support material inside the hood, this material is also electromagnetically transparent. In front and on top of the test item positioner is a layer of absorbing material used to prevent signal reflections that could compromise measurement accuracy. This absorbing material is necessary only to the extent that metal portions of the positioner extend into the beamwidth of the antenna. The hooded antenna is positioned in a cradle mounted to a heavy duty tripod. Its feed cable is routed outside the shielded enclosure by means of a bulkhead coaxial connector. Power and control cables for both the test item and its positioner enter the shielded enclosure through filters mounted to the exterior wall of the enclosure. The test item power cord is routed to an impedance standardizing device required for conducted measurements and then over the ground plane edge to troughs in the support material. From there, the power cord is routed to the test item positioner via a cylindrical hole provided in the support material and located over the positioner center. Test item interconnecting cables such as might be required for control, monitoring, etc. are similarly routed with the exception that they would bypass the impedance standardizing devices unless they were the object of conducted measurements. In the positioner, power and/or interconnection cables may use slip-rings to eliminate concern with cable twisting as the positioner is rotated. If slip rings are not used caution must be exercised to preclude excessive cable twisting. A circular ground plane of either copper or brass material is provided as a simulation of the ground connection the test item will have in its final installation. Since no single ground plane can simulate all of those possible in installations throughout FAA facilities, the recommended dimensions were chosen primarily for test convenience. These dimensions are a diameter of four feet and a thickness of 0.125 inches. The ground plane is grounded to the shielded room by means of a large braided strap soldered to the bottom of the ground plane and routed through the hole in the support material.

5.3.1.2 30 to 400 MHz Frequency Range

The extensive investigation of test configurations and procedures applicable to the 30 to 400 MHz frequency range were documented in Paragraph 4.4.4. In this paragraph, it was noted that radiated measurements over this frequency range are essential because of the number and criticality of FAA

equipments that operate in the VHF frequency band. However, the investigation of test methods and procedures resulted in no measurement technique that would yield accurate and repeatable data. Of the techniques investigated, the one requiring a lossy material coating on the inside walls of the shielded enclosure was most promising. Its evaluation to date, however, has only involved scale models of shielded enclosures; consequently, it could not be fully recommended until a thorough evaluation using full size enclosures has been conducted.

In view of this situation, it is recommended that radiated measurements over the 30 to 400 MHz frequency continue to be made using the same shielded enclosure configuration recommended for the 400 MHz to 12 GHz tests. The test procedures should be those required by MIL-STD-462 and the biconical antenna required by MIL-STD-461A for the 30 to 200 MHz frequency range should be used. In addition, the AEL Model ASN 1232A, or equivalent, antenna should be used between 200 and 400 MHz. This antenna provides circular polarization with a planar log spiral design. It is therefore a companion to those antennas recommended for use in hoods at the higher test frequencies.

It is again noted that measurements made with these test configurations and procedures will yield results that are difficult to repeat and inaccurate. The recommendation that such measurements continue to be made should be interpreted only as a means of maintaining pressure regarding the need for further investigations.

5.3.1.3 14 kHz to 30 MHz Frequency Range

Analysis of the test configuration presently required by MIL-STD-462 for this frequency range indicates that it yields measurement data comparable to that obtained in a shielded anechoic chamber. Therefore, the currently specified MIL-STD-462 test configuration is recommended for FAA use over this frequency range.

5.3.2 Test Method RE03, Radiated Spurious and Harmonic Emissions, 14 kHz to 40 GHz

The test configuration and procedures recommended for FAA use over this frequency range are those specified in Notice 3 to MIL-STD-462, with

the exception of the test antennas. The recommended antennas as a function of test frequency areas follows:

14 kHz to 30 MHz: 41 inch monopole antenna with tuning network

30 to 400 MHz: biconical (30 to 200 MHz) and planar log-spiral antennas

400 MHz to 10 GHz: hooded planar log-spiral antennas

10 to 40 GHz: horn antennas with dish reflectors

These antenna recommendations are made so the same antennas required for Test Method RE02 can also be used for this test method. Over the 10 to 40 GHz frequency range, the dish reflectors should be 18, 12, and 6 inches for 10 to 18 GHz, 18 to 26 GHz, and 26 to 40 GHz frequency ranges, respectively.

5.3.3 Test Method RS03, Radiated Susceptibility, 30 MHz to 10 GHz, Electric Field

As was the case in Test Method RE02 for radiated emissions, the procedures of MIL-STD-462 are recommended for FAA adoption; however, the recommended test configuration involves hooded antennas and an absorber lined wall in the shielded enclosure. This configuration is described in detail for Test Method RE02 (Para. 5.3.1.1 and Para. 5.3.1.2). Because of saturation and overheating problems with the 41 inch monopole antenna and its tuning network, susceptibility measurements over the 14 kHz to 30 MHz frequency range are not recommended for this test method (see Para. 5.3.4). The previously recommended biconical, planar log-spiral and hooded antennas are applicable for this test method. In the case of the hooded antennas, this recommendation is based on the assumptions that reciprocity holds and that the AEL antennas will tolerate the power necessary to develop a one volt per meter field at a one meter separation distance. Although susceptibility tests using the one volt per meter performance limit were not conducted during these investigations, on numerous occasions hooded AEL antennas were used as the source when antenna patterns are being plotted. All indications were that reciprocity will hold. If the power necessary to establish the one volt per meter field can not be developed by AEL planar log-spiral

antennas, comparable antennas manufactured by Transco, Inc. are available. These antennas deposit the radiating elements on a ceramic material capable of handling appreciably more power than phenolic material used by the AEL antennas.

5.3.4 Test Method (T) RS04, Radiated Susceptibility, 14 kHz to 30 MHz

The recommended configuration and procedures for this test method are those presented in Method RS03 of Notice 3 to MIL-STD-462. This notice deletes use of the 41 inch monopole antenna and its associated tuning network and requires use of either a long wire antenna or parallel plate line configuration. Although either the long wire antenna or parallel plate line will yield valid susceptibility data for FAA equipments, the long wire antenna is preferred since it doesn't require any extensive construction, can be easily used in the shielded enclosure, and reduces the restrictions on test item size.

5.3.5 Test Method RE05, Radiated Emissions, Broadband, 150 kHz to 400 MHz

The test configurations and procedures recommended for FAA adoption are those required by Notice 3 to MIL-STD-462. These configurations and procedures are applicable to Class IV generators and engine-driven motor vehicles. The test item is set up in a fixed position on the earth with a two meter spacing between the test antenna and test item perimeter. The upper frequency limit for broadband measurements is recommended to be 400 MHz. Recommended test antennas are the 41 inch monopole with associated tuning network (150 kHz to 30 MHz), the biconical (30 to 200 MHz), and the planar log-spiral (200 to 400 MHz).

5.4 Performance Limit Recommendations

5.4.1 Approach to Limit Derivation

Many of the requirements in present EMC standards are confusing and without apparent explanation; however, no aspect of EMC standards is as thoroughly unexplained as are the performance limits that have evolved

as one standard after another has emerged. It has been correctly noted that "the historical road from the first formulation of interference limits to their present state has been long in time but short in technical advancement" [44]. Almost every effort to analyze their scientific basis ends with the general conclusion that they are arbitrary in origin, perhaps irrelevant and bear little or no direct relationship to the achievement of system level EMC. Consequently, efforts to establish new performance limits based on existing limits is at best a speculative venture.

5.4.2 Test Methods RS03 and (T) RS04, Radiated Susceptibility, 14 kHz to 10 GHz

With this a priori knowledge of the effort involved in establishing valid performance limits for recommendation to FAA, a rather simplified approach generally unencumbered by limits in present and past standards was adopted. This approach began with analyses of all available data defining the operational electromagnetic environment at FAA facilities. This environment is known to vary considerably as a function of such factors as time of day, facility type, relative size of facility, nature of activity, etc. Therefore, it is not possible to have definitive data for each of these conditions. Fortunately, a series of measurements [6]-[9] were recently completed in which operational electromagnetic environments in three typical ARTCC facilities were extensively defined. A portion of these measurement results were in the form of narrowband radiated emission levels at 59 facility locations chosen to reflect contributions of both automated and nonautomated electronic equipments. Measurement results for these locations were presented for each of three different ARTCC facilities. Additionally, comparable measured data were presented for radiated broadband emission levels. The applicable frequency range for both narrowband and broadband data was 150 kHz to 1 GHz. Correction factors had been incorporated such that all data were in units of decibels above one microvolt (dB μ V).

To reduce these data to a usable form, five discrete frequencies (150 kHz, 1 MHz, 10 MHz, 100 MHz, and 1 GHz) were selected. The reported narrowband and broadband emission levels at each frequency and at each facility location were tabulated. From this tabulation, a composite emission level which approached the maximum measured level was identified for each frequency

at all three facilities. This level was then plotted in units of dB μ V versus frequency and a straight line curve was used to connect the data points. "Reverse" correction factors were then determined so the narrowband and broadband emission levels could be presented in units of dB μ V per meter (dB μ V/M) and dB μ V per meter per megahertz bandwidth (dB μ V/m/MHz), respectively. These factors were then combined with the plotted data, and the result provided a composite view of the measured operational electromagnetic environment in 118 locations in three typical ARTCC facilities. These results are graphically shown in Figures 50 and 51. As is evident from the figures, the maximum narrowband and broadband environments were approximately 76 dB μ V/m from 1 to 100 MHz and 115 dB μ V/M/MHz from 150 kHz to 1 MHz, respectively. Therefore, any new equipment located in these facilities would have to be capable of withstanding these narrowband and broadband levels.

There was an awareness that these levels were applicable for only three ARTCC facilities, and that they were not necessarily representative of operational environments at other FAA facilities; however, no measured data defining environments at these other facilities were available. Consequently, 20 dB (a voltage factor of 10) was added to the 76 dB μ V/m level to account for the possibility of higher emission levels at other types of FAA facilities, and the maximum narrowband environmental level became 96 dB μ V/m (63 millivolts per meter). Finally, a safety factor of 24 dB was incorporated, largely for convenience, to make the final maximum narrowband environmental level 120 dB μ V/m (1.0 volt per meter). Rather than have multiple susceptibility levels as a function of frequency, the 1.0 volt per meter level was made applicable from 14 kHz to 10 GHz.

The 1.0 volt per meter level derived as described above is recommended for FAA adoption as the susceptibility limit for the 14 kHz to 10 GHz frequency range. When this recommended level was compared with comparable limits from other EMC standards and specifications, the 1.0 volt per meter appeared to represent an average of other limits. For example, this level is coincident with the level required by MIL-STD-461A (Para. 6.19), but is 20 dB lower than the limit required by MIL-STD-826 [45]. Meanwhile, the MIL-I-6181D [46], MIL-I-26600 [47], and MIL-I-11748 [48] narrowband susceptibility limits were approximately 20 dB below the recommended 1.0 volt per meter level.

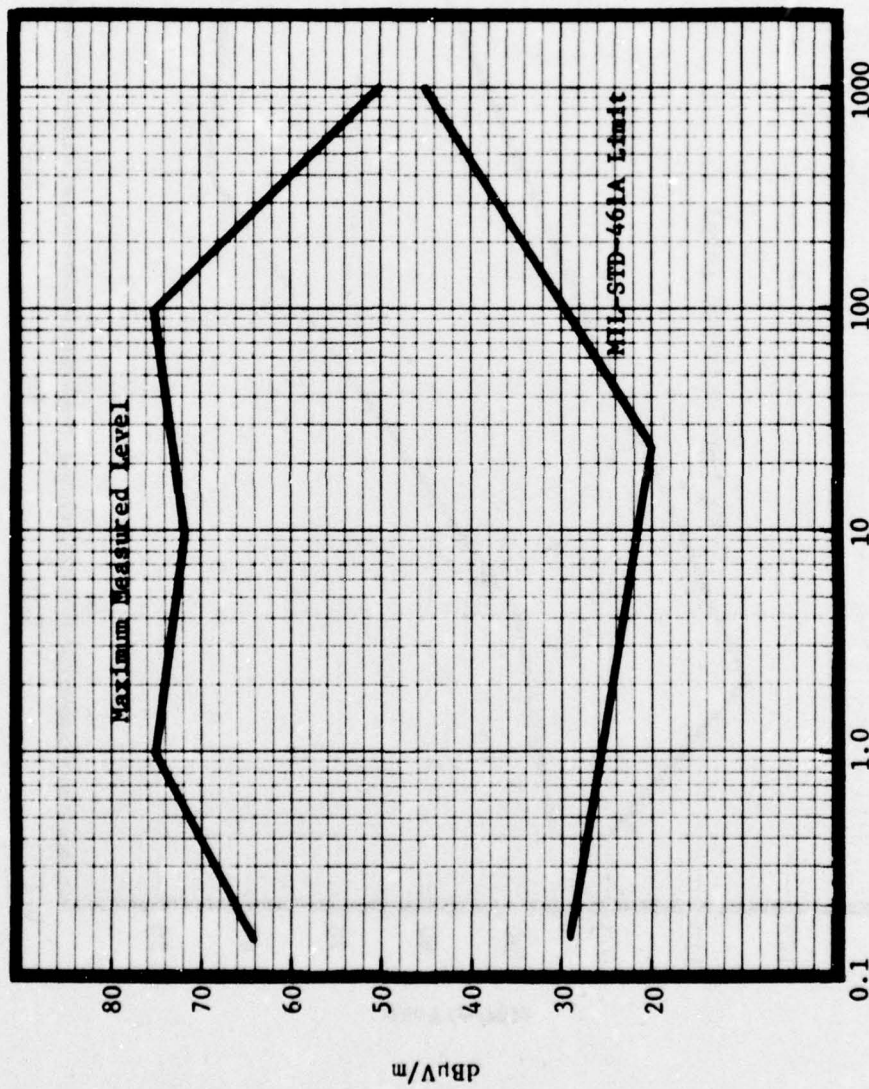

Figure 50. Narrowband Emission Levels Measured in ARTCC Facilities.

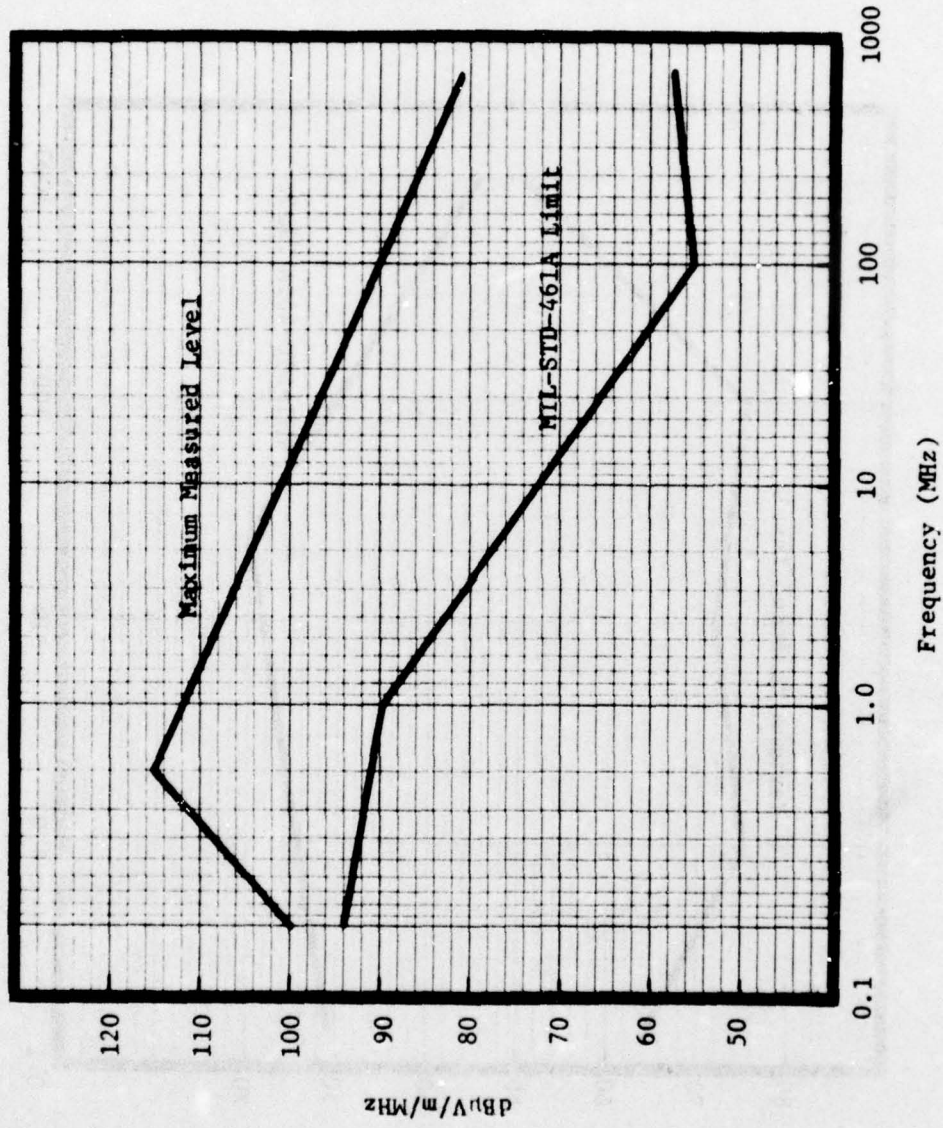

Figure 51. Broadband Emission Levels Measured in ARTCC Facilities.

It is noted that present modifications to MIL-STD-461A (Notices 2 and 3) increase the susceptibility limit for Test Method RS03 to 10 volts per meter (plus an optional 20 volts per meter) over major portions of the frequency band. Also, the proposed MIL-STD-461B will reportedly [49] require a susceptibility limit of 10 volts per meter and higher for all sheltered equipments. It is equally interesting to note that the change in MIL-STD-461B is said to be "due to both political considerations and operating experience" [50].

Although there was a desire for this recommended limit to be consistent with future trends in MIL-STD-461A, the fact is the available data obtained during extensive facility measurements does not support an EMS limit greater than the 1.0 volt per meter.

5.4.3 Test Method RE02, Radiated Emissions, 14 kHz to 10 GHz, Electric Field

In the derivation of a narrowband emission limit, it was evident that the total allowable emission level must be below the susceptibility level. This difference in limit levels must not only allow for a safety margin between the emission and susceptibility levels, but must also account for (1) the possibility that more than one emission may be present at a given frequency and time, (2) the decoupling between equipments, and (3) the accuracy with which radiated measurements can be made.

The safety margin needed between susceptibility and emission limit levels was considered with the anticipation that a future FAA system level standard will impose a safety margin (possibly 6 dB) in addition to the equipment level standard. Consequently, a 6 dB separation between limit levels was felt to be sufficient for inclusion in the equipment level standard. It was considered unlikely that two or more narrowband emissions would occur at the same time and frequency and in phase; however, to account for the possibility that at least two such emissions might so occur, the emission limit level was further reduced by 6 dB. The accuracy of commercially available test equipment and personnel operation of this equipment provided the basis for an additional 3 dB reduction in the emission limit level. The decoupling between equipments within a FAA facility is virtually impossible

to predict. For example, equipments may be located side-by-side or separated by a hundred feet and a metal wall. As an arbitrary estimate of this decoupling, a further reduction of 3 dB in the emission limit level was established. Finally, an addition of 40 dB was incorporated as a means of assuring that undesired emissions were reduced to a point that they didn't unnecessarily contribute to spectrum pollution. This overall value of 58 dB was then rounded off to 60 dB and then subtracted from the susceptibility limit of 120 dB μ V/m. The result is a recommended narrowband emission limit of 60 dB μ V/m. This limit is plotted in Figure 52 with the present MIL-STD-461A limit and the relaxed MIL-STD-461A limit required by the Air Force. Also shown for reference is the narrowband emission limit imposed by the Comite' International Special Des Perturbations Radioelectriques (CISPR) and the Verband Deutscher Elektrotechniker (VDE) organization [51] in Europe. From this plot, it is seen that the recommended limit is more lenient than the most liberal MIL-STD-461A limit by an average of approximately 15 dB. As was the case for the recommended susceptibility limits, there was a desire to make these recommended limits consistent with those existing in MIL-STD-461A; however, the available data defining the electromagnetic environment at FAA facilities would not permit this without introducing totally arbitrary "correction" factors.

Derivation of a recommended broadband emission limit was undertaken along two independent courses. The first of these was parallel to the course pursued in deriving the recommended narrowband emission limit. Therefore, the broadband emission levels measured at the ARTCC facilities and plotted in Figure 51 provided the starting point. Added to this was (1) a 20 dB factor to account for the possibility that higher level signals might exist at other types of FAA facilities and (2) a safety factor of 24 dB. The result became a curve that in effect represented a broadband susceptibility limit comparable in nature to the 1.0 volt per meter narrowband susceptibility limit. Then to assure that broadband emissions were not allowed to exist with sufficient amplitude to exceed this limit, various factors were derived to modify this susceptibility limit to yield a broadband emission limit. As in the case of the narrowband emission limit, these factors totaled 58 dB. They were applied to the broadband susceptibility levels to yield a broadband emission limit as shown in Figure 53.

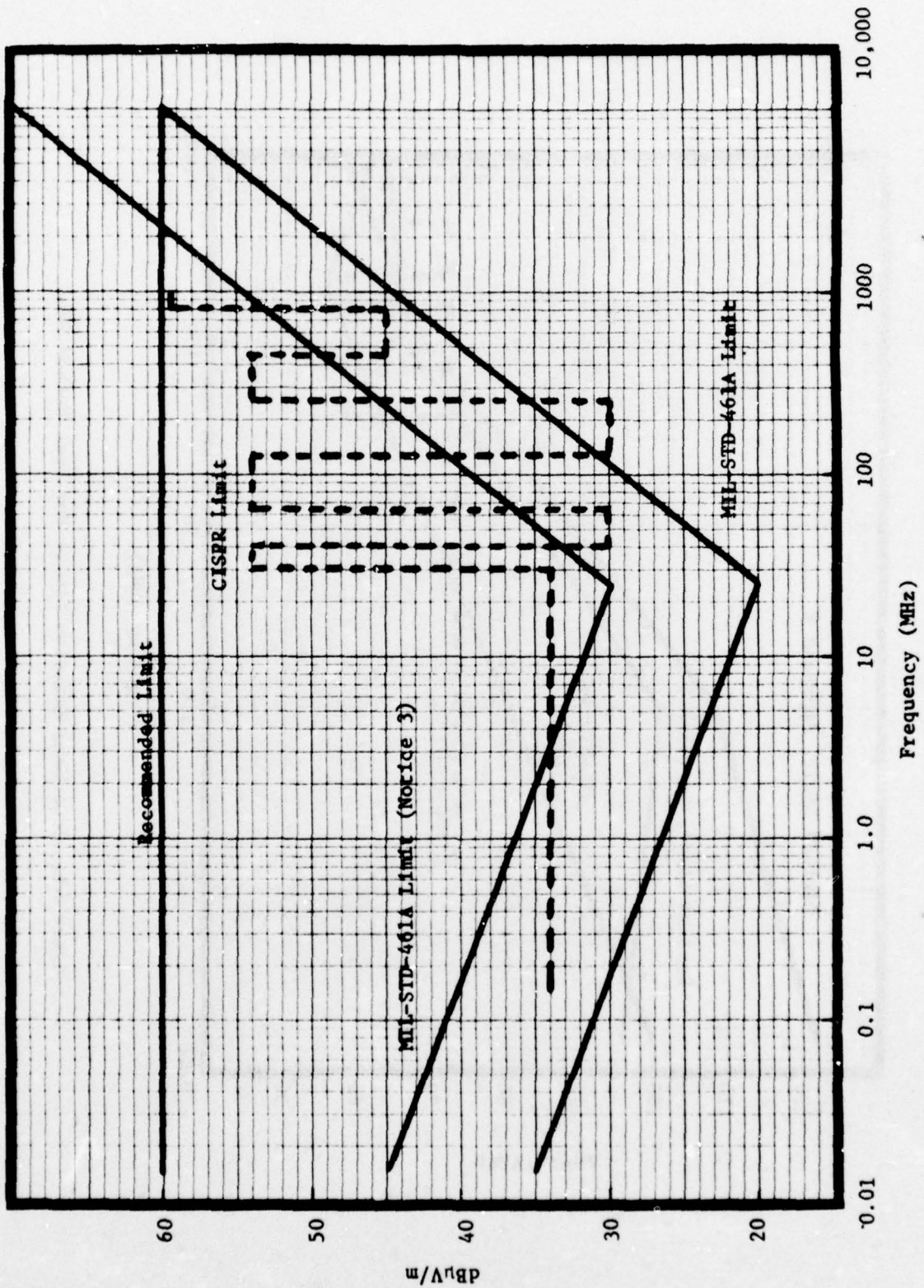

Figure 52. Narrowband Emission Limits for Test Method RE02.

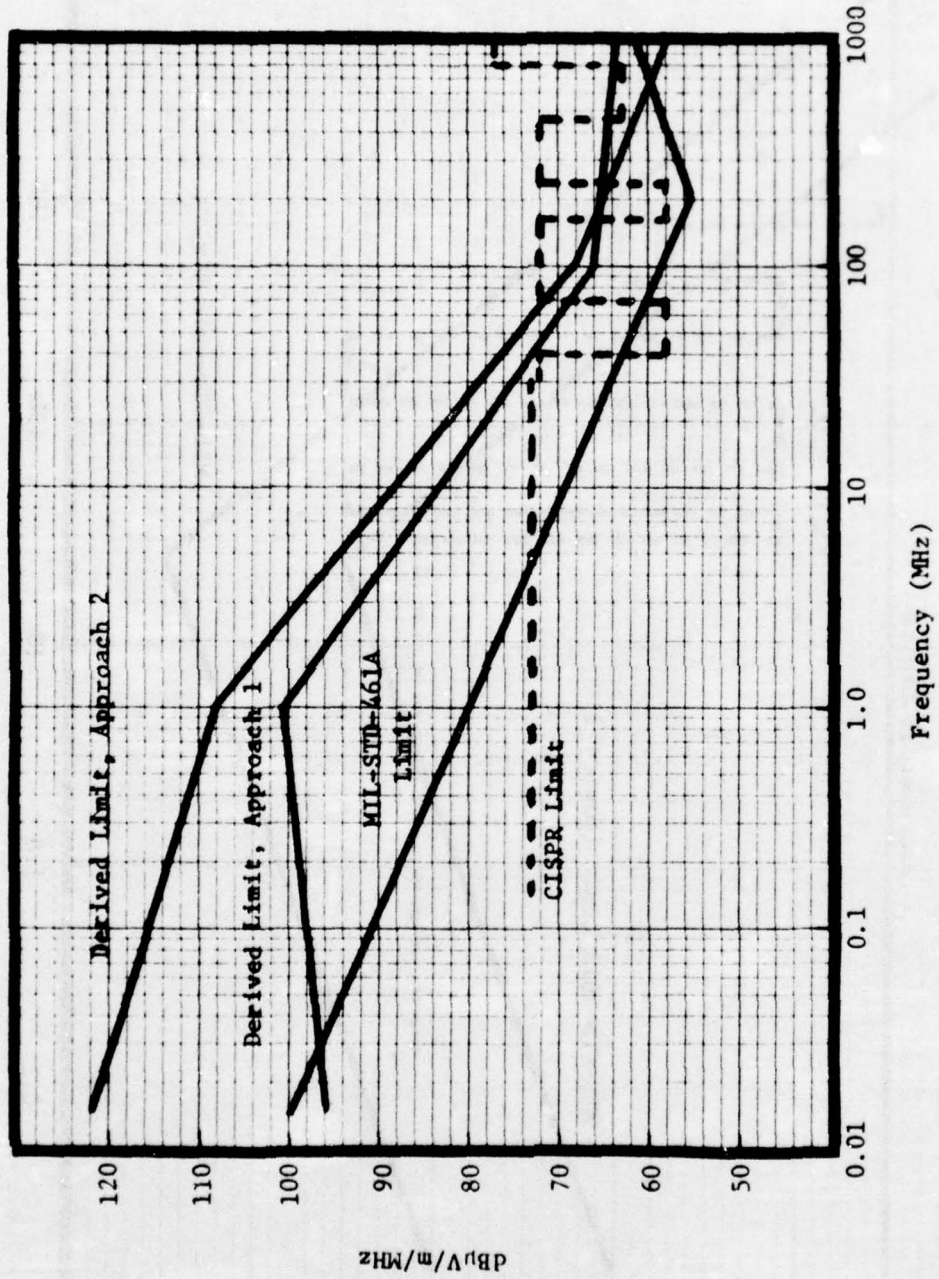

Figure 53. Broadband Emission Limits For Test Method RE02.

The second course taken during this effort involved deriving broadband emission limits from existing narrowband emission limits.

The broadband limits were to be derived such that the previously derived narrowband emission limits were not exceeded. Two factors had to be considered in this derivation. First, there exists the possibility that the maximum peak level resulting from the uncorrelated components of a broadband emission will not be present during the short time over which a measurement is made. If this maximum level is present, there is an additional possibility that it will be of such short duration that the measuring device will indicate the average peak amplitude rather than the desired maximum peak amplitude. The maximum peak amplitude of the combined emissions is the quantity which must not exceed the narrowband emission limit. Therefore, the broadband limit must conservatively restrict the average peak amplitude to some level below the permissible narrowband level. Secondly, a broadband emission by definition exhibits a frequency spectrum wider than the bandwidth of the measuring instrument. Consequently, the bandwidth of the measuring instrument will influence the detected level. For a uniformly flat spectrum, the detected voltage level will increase in proportion to the bandwidth of the measuring instrument. The broadband limit must reflect this proportionality in order to maintain consistencies between measurements made with instruments with different bandwidths. These factors were separately considered in the establishment of broadband limits to the extent indicated in the following discussion.

If the emissions within the measurement bandwidth are uncorrelated, the peak signal level at the instant of measurement will not necessarily be the maximum level which could result if all emissions were instantaneously added together. The probability of random emissions adding together to produce an emission in excess of some predetermined level has been explored in detail by communications specialists. If the narrowband limit is viewed as an "emission" level and the broadband limit as a "noise" level, then a separation factor can be established which will minimize the possibility that the broadband emission will ever equal or exceed the narrowband limit.

The likelihood of the peak level of an uncorrelated broadband emission equaling or exceeding the narrowband limit can be reduced to 1:100 by reducing the broadband limit to at least 10 dB below the narrowband limit [52].

An order of magnitude improvement to 1:1000, which represents a potential error of less than 0.1 percent, can be achieved by reducing the broadband limit to 12 dB below the narrowband limit. To reflect this high confidence level of 99.9 percent, the broadband emission limits should be expressed as:

$$\text{Broadband Limit} = \text{Narrowband Limit} - 12 \text{ dB.}$$

Since the bandwidth of the measuring instrument also affects the indicated level on the field intensity meter, a correction factor based on the ratio of the impulse bandwidth (IBW) to a reference bandwidth is necessary to relate broadband emissions to narrowband emissions. The IBW is the equivalent noise bandwidth (sometimes referred to as the instrument bandwidth) of the measuring instrument. The equivalent noise bandwidth is defined as that ideal rectangular passband function which would transfer the same noise power to the receiver detector as is actually transferred by the RF and IF filters.* Historically, in the establishment of broadband limits, a typical or maximum IBW has been assumed and the narrowband limit then increased by the amount of the resulting correction factor. With currently available instrumentation, the IBW will vary from 100 Hz to as much as 10 kHz over a frequency range of 1 kHz to 30 MHz. Since test instruments with different bandwidths may be used by different organizations, the proper correction factor is difficult to predict in advance. Consequently, instead of presenting the broadband limits in a graphical form based on some assumed bandwidth, the broadband limit should be derived by test personnel using the narrowband limit and it will be a function of the specific measuring instrument employed. The IBW must therefore be determined for each measuring instrument if it is unknown. Generally, the IBW is relatively constant across the tuning range of a particular tuning head since it is generally determined by the IF stage. However, it quite likely will be different for different tuning heads. For measuring instruments such as spectrum analyzers and the continuously tunable field intensity meters, the IBW is probably constant over a particular swept frequency region.

*For a specific mathematical definition, see Information Transmission, Modulation, and Noise by Mischa Schwartz, McGraw-Hill Book Co., Inc. New York, 1959.

A first-order approximation of the equivalent noise bandwidth of a synchronously tuned filter is given by the 6 dB bandwidth. This approximation is not valid, however, for many types of filter responses. The IBW of a field intensity meter may be accurately determined through the use of a standard signal generator and an impulse generator calibrated in terms of voltage per frequency unit. First, the field intensity meter is tuned to a narrowband signal of known level (determined by the calibrated output attenuator of the signal generator) and the indicated reference level is noted. The field intensity meter function switch is then switched to the broadband or "Peak" position. The calibrated impulse generator is then substituted for the narrowband source and the level is adjusted to obtain the previously noted reference level. The IBW in MHz is then determined from the following relationship:

$$\text{IG Output} - \text{SG Output} = 20 \log_{10} \frac{1 \text{ MHz}}{\text{IBW}},$$

where IG Output = impulse generator output in dB/μV/MHz and

SG Output = signal generator output in dB/μV.

This bandwidth correction factor in dB is added to the basic limit. Consequently, the expression for the broadband emission limit then becomes

$$\text{BB Limit} = \text{NB Limit} + 20 \log_{10} \frac{1 \text{ MHz}}{\text{IBW}} - 12 \text{ dB},$$

where BB Limit = broadband limit in dBμV/m/MHz, and

NB Limit = narrowband limit in dBμV/m.

Since the narrowband emission limit is a constant value of 60 dBμV/m over the frequency range of 14 kHz to 10 GHz, the expression for radiated broadband emission limits may be written as

$$\text{BB emission Limit} = 48 \text{ dB} + 20 \log \frac{1 \text{ MHz}}{\text{IBW (MHz)}}.$$

To illustrate the relative levels which might be obtained for various instruments, some typical measurement bandwidths were assumed and the resultant limits were calculated over a 150 kHz to 1 GHz frequency range. These limits are compared in Figure 53 with the limits presently imposed by MIL-STD-461A and the limits derived by the first approach described above. For further comparison, the broadband emission limit used for European EMC tests

and imposed by Comité International Spécial Des Perturbations Radioélectriques (CISPR) and Verband Deutscher Elektrotechniker (VDE) standards [51] is also plotted in Figure 53.

The broadband emission limit recommended for FAA adoption is the one derived by the first approach described; however, since broadband radiated tests are recommended only to a frequency of 400 MHz, this limit is applicable to only 400 MHz. It is noted that, in the mid-frequency range, these recommended limits are more lenient than the present MIL-STD-461A limits by as much as 21 dB. At the high and low frequency ends, the limits imposed by MIL-STD-461A and those recommended for FAA adoption are essential coincident.

5.4.4 Test Method RE03, Spurious and Harmonic Emissions, 14 kHz to 40 GHz

No specific data were available on levels of spurious and harmonic emissions from transmitters at FAA facilities; however, it was considered necessary that these emissions be reduced to the maximum permissible level by the state-of-the-art. The primary basis for this was the fact that (1) FAA operations require the use of large numbers of transmitters and receivers and (2) the most often expressed interference problem at FAA facilities was caused by environmental radiation. Previous experience in spectrum signature testing had established that well designed transmitters with relatively low peak power outputs typically exhibit low order harmonic emissions that were reduced approximately 60 dB below the fundamental. As either the power output level or harmonic number increased, the harmonic emission level must correspondingly reduce if interference and spectrum pollution are to be prevented. In most instances, well designed output stages in transmitters result in spurious emission levels that are somewhat below the permissible harmonic emission levels.

In reviewing the MIL-STD-461A limits for this test method, it was noted that a constant -60 dB level for both spurious and harmonic emissions was required over an appreciable range of output power levels--100 to 10,000 watts peak. The fact that the spurious and harmonic levels were identical and the constant limit over a wide range of transmitter output power levels were both considered undesirable. In Notice 3 to MIL-STD-461A, it was observed that a more desirable limit was imposed. This limit, shown in Figure 54,

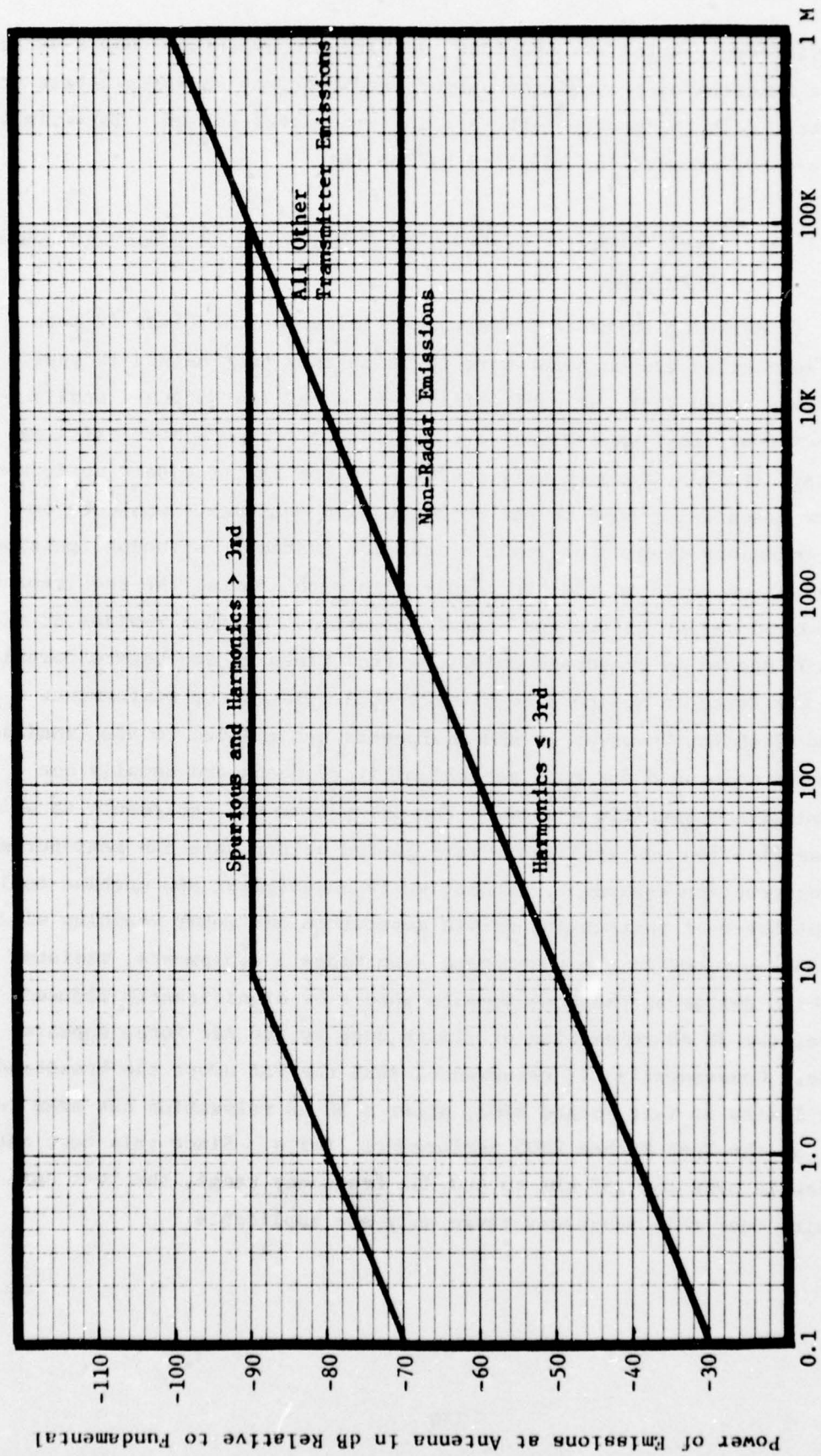

Power of Fundamental Emission (Watts Peak)

Figure 54. Recommended Transmitter Spurious and Harmonic Emission Limits.

requires different limits for spurious and harmonic emissions, has a variable level as a function of transmitter output, and requires emission levels to be consistent with the state-of-the-art in transmitter design. This limit is therefore recommended for adoption by the FAA.

5.4.5 Test Method RE05, Radiated Emissions, 150 kHz to 400 MHz,
Broadband

In deriving suitable performance limits for the Class IV motor vehicles and engine driven generators to which this test method is applicable, it was noted that the basic MIL-STD-461A and its Notice 4 modification both impose requirements that are applicable for much more critical equipments. If this approach were followed by the FAA, the same performance limits for essential ground-to-air communication equipments would be imposed on emissions from motor vehicle ignition systems. Although ignition system emissions could be made to comply with such limits, the requirement was considered unjustifiable and cost-ineffective. Further reviews of requirements imposed on broadband emissions from Class IV equipments revealed that the Air Force in Notice 3 to MIL-STD-461A relaxed the performance limits by 30 dB for "subsystems and equipments not related to electronics or communications used for many general military needs and usually not associated with a specific system." The subsystems and equipments to which this classification was applicable were listed as portable and semi-portable tools, construction equipment, automotive type equipment and machine tools. In view of the fact that engine driven generators and motor vehicles will be located and operated in areas separate from Class I equipments, radiated levels which arrive at these equipments should be significantly reduced. Therefore, the 30 dB relaxation of limits used by the Air Force appears realistic. Consequently, it recommended that the FAA adopt the broadband emission limits of Test Method RE02, after a 30 dB relaxation has been incorporated, as the Test Method RE05 performance limits. Since this test method is applicable over the 150 kHz to 400 MHz frequency range, the Test Method RE02 limits over this frequency range only are applicable.

6. SUMMARY

In the preceding paragraphs, radiated emission and susceptibility test requirements currently imposed by MIL-STD-461A and MIL-STD-462 have been extensively analyzed to determine their applicability to FAA equipments. Resulting from this analysis has been a series of recommendations aimed at assuring that only justified test requirements are imposed by the FAA, and that these requirements yield data which are accurate, repeatable, and useful in establishing system level EMC. To assist in determining the recommended tests and their applicable limits, Table VII and Figures 55 and 56 have been prepared. Table VII presents the recommended test methods as a function of frequency range and equipment class; additionally, the measurement antennas needed for each test are given. Figures 55 and 56 present the performance limits recommended for each test method. It is noted that no test methods are recommended to complement the broadband emission test in Test Method RE02 or the broadband emission test in Test Method RE05; therefore, no performance limits for these tests are shown in Figures 55 and 56.

In Appendices B and C, modifications to the radiated requirements in MIL-STD-461A and MIL-STD-462, respectively, are presented. These modifications when used with the two basic standards, comprise a FAA document to be included in future electronic equipment Procurement Specifications for the purpose of imposing realistic electromagnetic emission and susceptibility controls.

It is noted as a part of this Summary that, throughout these technical investigations, efforts were made to determine whether recommendations herein were consistent with the conclusions drawn in the reports [6]-[9] which documented measured radiation levels in ARTCC facilities. For the most part, consistency has been realized. Where inconsistencies exist, they are largely attributable to a difference in philosophy. To illustrate, the measurement reports recommend in several instances that radiated performance limits in MIL-STD-461A be changed to conform with the measured electromagnetic environment. This recommendation does not consider the adequacy of the procedures used to measure the environment, the reliability and repeatability of the resulting data, or the fact that the electromagnetic environment can be changed via a program of EMC control. During these investigations, engineering judgements were made to account for these factors by means of a

TABLE VII

SUMMARY OF RECOMMENDED TEST METHODS

Test Method	Test Description	Frequency Range	Equipment Class	Antennas
RE02	Radiated Emissions, Electric Fields	14 kHz to 10 GHz	I, II, and III	14 kHz to 30 MHz: one 41 inch monopole antenna with tuning network 30 to 400 MHz: one biconical antenna and one planar log spiral antenna 400 MHz to 10 GHz: four hooded planar log-spiral antennas
RS03	Radiated Susceptibility, Electric Fields	30 MHz to 10 GHz	I, II, and III	30 MHz to 400 MHz: one biconical antenna and one planar log-spiral antenna 400 MHz to 10 GHz: four hooded planar log-spiral antennas
(T)RS04	Radiated Susceptibility, Electric Fields	14 kHz to 30 MHz	I, II, and III	Either long wire antenna or parallel plate line
RE03	Spurious and Harmonic Emissions	14 kHz to 40 GHz	I*	14 kHz to 30 MHz: one 41 inch monopole antenna with tuning network 30 MHz to 400 MHz: one biconical antenna and one planar log-spiral antenna 400 MHz to 10 GHz: four hooded planar log-spiral antennas 10 to 40 GHz: three horn antennas with dish reflectors
RE05	Radiated Emissions,	150 kHz to 400 MHz	IV	150 kHz to 30 MHz: one 41 inch monopole antenna with tuning network 30 to 200 MHz: one biconical antenna 200 to 400 MHz: one planar log-spiral antenna

*Transmitters Only

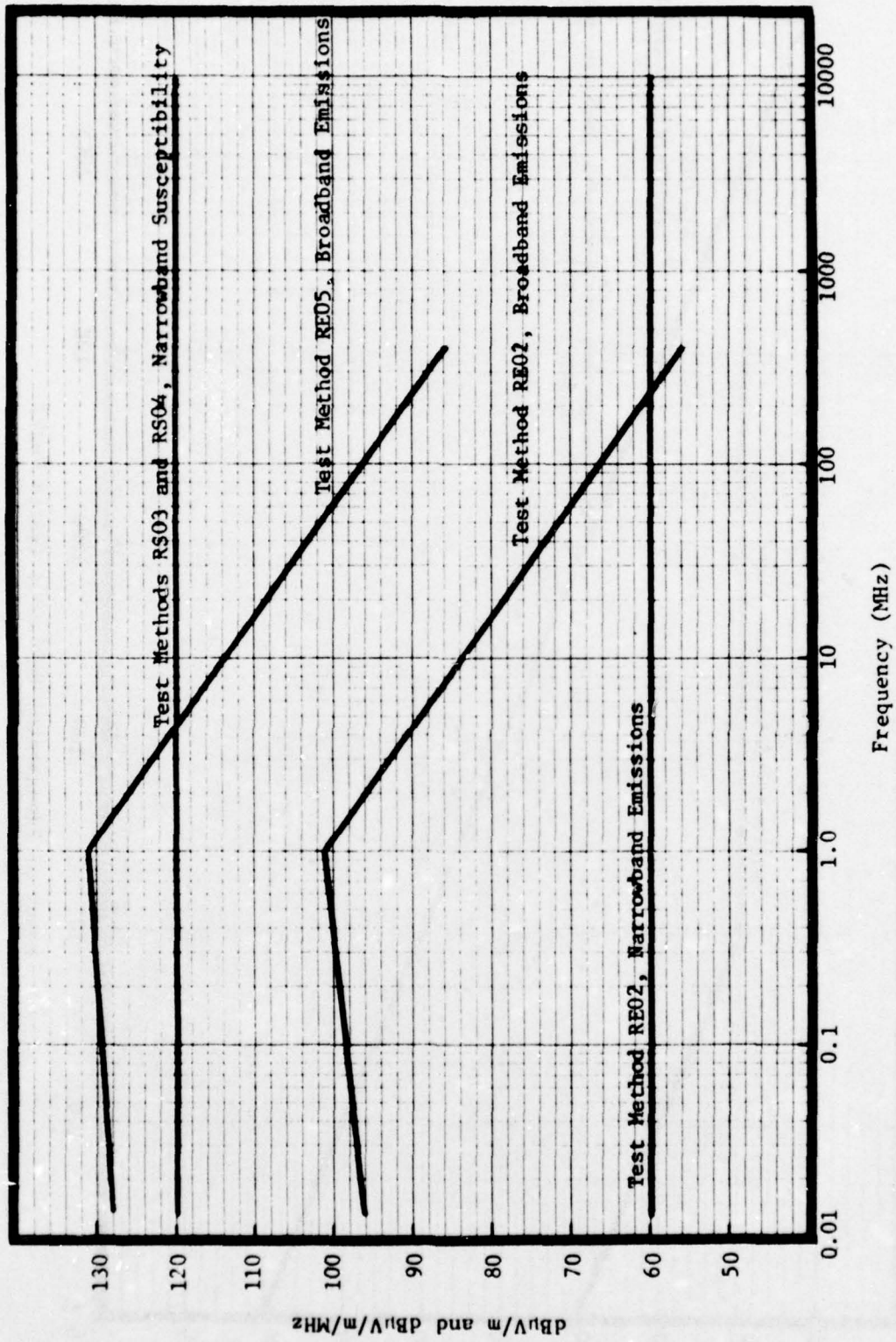

Figure 55. Recommended Performance Limits for Radiated Test Methods.

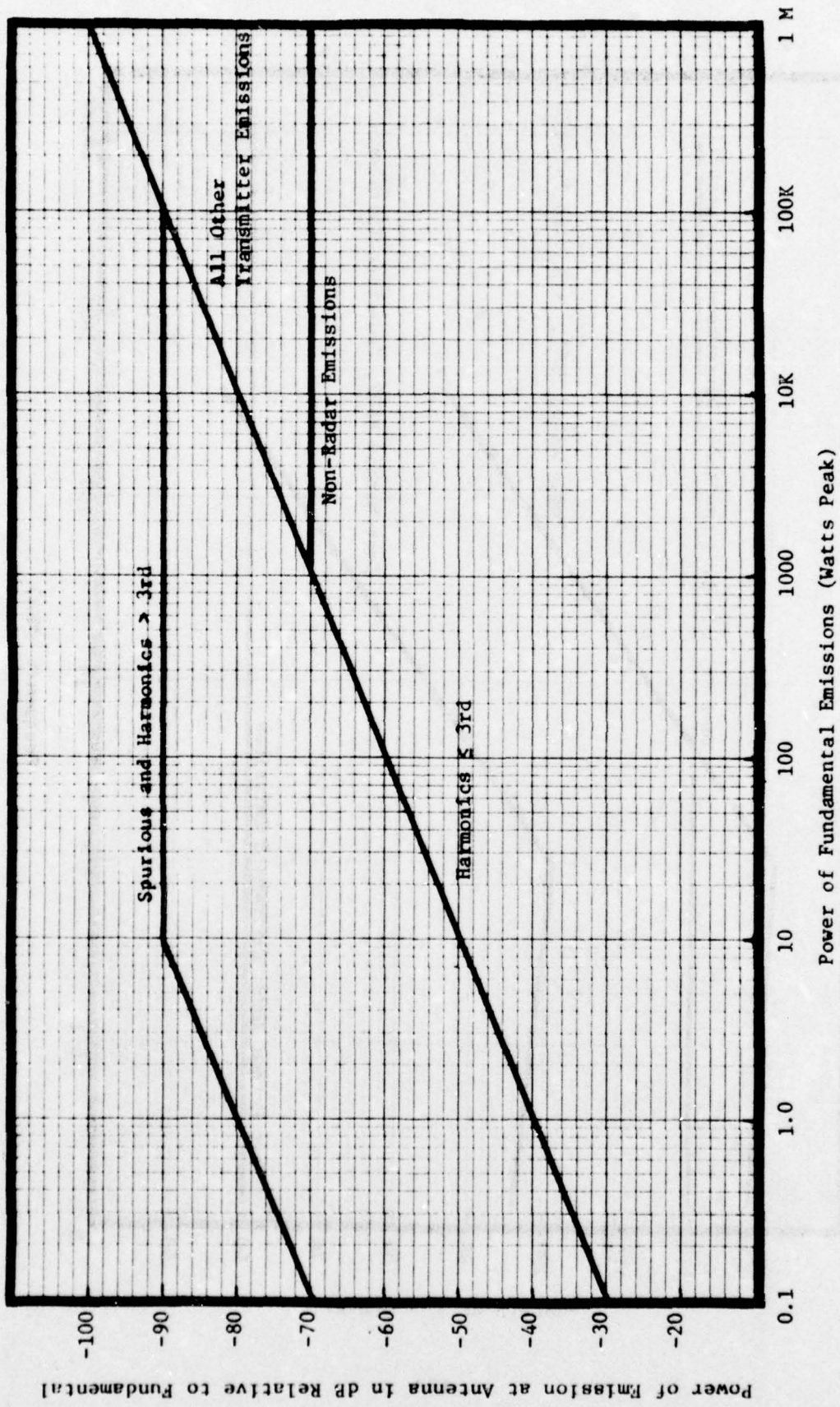

Figure 56. Recommended Transmitter Spurious and Harmonic Emission Limits

philosophical stance that viewed equipment performance and the ambient electromagnetic environment as integrally related. A degree of latitude was then possible in recommending levels for emission and susceptibility performance limits.

7. REFERENCES

1. Marce Eleccion, "The Promise of Air Safety," IEEE Spectrum, July 1975, p. 26.
2. MIL-STD-461A, "Electromagnetic Interference Characteristics, Requirements for Equipment," dated 1 August 1968.
3. MIL-STD-462, "Electromagnetic Interference Characteristics, Measurement of," dated 9 June 1966.
4. MIL-STD-463, "Definitions and System of Units, Electromagnetic Interference Technology," dated 9 June 1966.
5. D. R. J. White, "Electromagnetic Interference and Compatibility, Vol. 2, EMI Test Methods and Procedures," Don White Consultants, Inc., Germantown, MD, 1974, p. 9.24, para. 9.2.2.2.
6. M. V. Stone, "Test Report, Radiofrequency Interference/Electromagnetic Interference Measurements, Los Angeles Air Route Traffic Control Center, Report No. FAA-RD-74-11, March 1974.
7. M. V. Stone, "Test Report, Radiofrequency Interference/Electromagnetic Interference Measurements, Oakland Air Route Traffic Control Center," Report No. FAA-RD-74-28, May 1974.
8. M. V. Stone, "Test Report, Radiofrequency Interference/Electromagnetic Interference Measurement, New York Air Route Traffic Control Center," Report No. FAA-RD-74-110, August 1974.
9. M. V. Stone, "Radiofrequency Interference (RFI)/Electromagnetic Interference (EMI) Measurements, Air Route Traffic Control Centers," Report No. FAA-RD-75-30, April 1975.
10. Op cit., Ref. 6, Stone, p. 16, para. 8.1.4.
11. Op cit., Ref. 8, Stone, p. 18, para. 8.1.3.
12. Op cit., Ref. 7, Stone, p. 22, para. 8.2.2.
13. Op cit., Ref. 5, White, p. 9.2, para. 9.1.
14. E. W. Paschetag and D. W. Bodenheimer, "A Technique for Magnetic Field Susceptibility Testing," 1969 IEEE Electromagnetic Compatibility Symposium Record, June 1969, p. 116.
15. Op cit., Ref. 5, White, p. 10.6, para. 10.1.
16. Op cit., Ref. 8, Stone, p. 17, para. 8.14 and p. 21, para. 8.2.2.
17. Op cit., Ref. 7, Stone, p. 18, para. 8.1.4 and p. 23, para. 8.2.3.

18. Op cit., Ref. 6, Stone, p. 16, para. 8.1.5 and p. 18, para. 8.2.3.
19. "Spectrum Engineering - The Key to Progress," IEEE Joint Technical Advisory Committee, March 1968, p. 8, para. II.
20. Op cit., Ref. 5, White, p. 5.8, para. 5.1.4.
21. W. R. Free, et. al., "Electronic Equipment Interference Characteristics, Communication Type," Technical Report ECOM-02294-F, Contract DA36-039 AMC-02294(E), July 1966.
22. W. R. Free, et. al., "Electromagnetic Interference Measurement Methods - Shielded Enclosure," Technical Report ECOM-02381-F, Contract DA28-043 AMC-02294(E), December 1967.
23. W. R. Free, et. al., "Electronic Equipment Interference Characteristics - Communication Type," Quarterly Report No. 6, Contract DA36-039 AMC-02294(E), 15 July 1964 to 15 October 1964.
24. W. R. Free, et. al., "Electronic Equipment Interference Characteristics - Communication Type," Quarterly Report No. 7, Contract DA36-039 AMC-02294(E), 15 October 1964 to 15 January 1965.
25. W. R. Free and C. W. Stuckey, "Electronic Equipment Interference Characteristics - Communication Type," Quarterly Report No. 8, Contract DA36-039 AMC-02294(E), 15 January 1965 to 15 April 1965.
26. W. R. Free, et. al., "Electronic Equipment Interference Characteristics - Communication Type," Quarterly Report No. 9, Contract DA36-039 AMC-02294(E), 15 April 1965 to 15 July 1965.
27. W. R. Free, et. al., "Electronic Equipment Interference Characteristics - Communication Type," Quarterly Report No. 10, Contract DA36-039 AMC-02294(E), 15 July 1965 to 15 October 1965.
28. W. R. Free and C. W. Stuckey, "Electromagnetic Interference Measurement Methodology, Communication Equipment," Technical Report ECOM-0189-F, Contract No. DAAB07-68-C-0189, October 1969.
29. W. R. Free, "Electromagnetic Interference Measurement Methodology, Communication Equipment," Technical Report ECOM-0189-1, Contract No. DAAB07-68-C-0189, August 1968.
30. F. E. Croxton, Elementary Statistics, Dover Publications, Inc., New York, NY, 1953, pp. 120-126.
31. R. E. Collin, "Foundations of Microwave Engineering," McGraw Hill Co., New York, NY, p. 98, Eq. 3.99.
32. G. W. Bechtold, et. al., "Electromagnetic Field Probes," Quarterly Report No. 1, Contract DAAB07-71-C-0306, April 1972.

33. W. R. Free, et. al., "Compact Chamber for Impedance and Power Test of VHF Whip Antennas," Final Report, Contract No. DAAB07-67-C-0575, October 1968.
34. H. A. Mendez, "Meaningful EMC Measurements in Shielded Enclosures," 1969 IEEE Electromagnetic Compatibility Symposium Record, June 1969, p. 137.
35. W. R. Free, et. al., "Electromagnetic Field Probes," Final Report, Contract DAAB07-71-C-0306, March 1973.
36. Op cit., Ref. 5, White, p. 10.14, Figure 10.7.
37. Op cit., Ref. 6, Stone, p. 11, para. 7.2.
38. Op cit., Ref. 6, Stone, p. 11, para. 7.3.
39. Op cit., Ref. 8, Stone, p. 11, para. 7.2.
40. Op cit., Ref. 7, Stone, p. 12, para. 7.3
41. Op cit., Ref. 5, White, p. 9.43, para. 9.4.
42. Op cit., Ref 5, White, p. 9.12, para. 9.1.2.3.
43. D. R. J. White, "Electromagnetic Interference and Compatibility, Vol. 4, EMI Test Instrumentation and Systems," Don White Consultants, Inc., Germantown, MD, p. 4.7, para. 4.2.
44. C. B. Pearlston, "Historical Analysis of Electromagnetic Interference Limits," Air Force Report No. SSD-TR-67-127, Contract No. AF 04 (694)-1001, April 1967, p. 45.
45. MIL-STD-826, "Electromagnetic Interference Test Requirements and Test Methods," 20 January 1964.
46. MIL-I-6181D, "Interference Control Requirements, Aircraft Equipment," 25 November 1959.
47. MIL-I-26600, "Interference Control Requirements, Aeronautical Equipment," 9 May 1960.
48. MIL-I-11748, "Interference Measurement, Radio, Methods and Limits: 14 kHz to 1000 MHz," 30 August 1954.
49. Op cit., Ref. 5, White, p. 10.18, Table 10.4.
50. Op cit., Ref. 5, White, p. 10.17, footnote.
51. P. M. Rostek, "Electromagnetic Emissions and Susceptibility In Digital Computers," National Cash Register Company, Data Processing Division, San Diego, CA.

52. Akima Hiroshi, "The Error Rates in Multiple FSK Systems and the Signal-to-Noise Characteristics of FM and PCM-FSK Systems," Technical 167, NBS, Boulder, CO, March 1963, AD 492 243.

APPENDIX A

Radiated Test Requirements for Overhead Power Lines

METHOD RE06

RADIATED EMISSIONS, 14 kHz to 1 GHz, OVERHEAD

POWER LINES

1. Purpose and Applicability - The purpose of this procedure is to measure radiated emissions from overhead power lines operating at voltages up to 1000 kV. The measurements shall be made in the frequency range from 14 kHz to 1 GHz.

2. Apparatus - Test apparatus shall consist of the following:
 - (a) EMI Meter (in PEAK position).
 - (b) Antennas.

3. Test Setup and Procedure
 - 3.1 The test setup shall be as shown in Figure A-1.

 - 3.2 Measurement Locations - Measurements will usually be required near a critical area. In order to determine if the power line is the source of interference, measurements will be necessary at two or more locations along the line length. For voltages from 0 to 70 kV, measurements are made opposite tower or pole on one side only. For voltages from 70 to 1000 kV, measurements shall be made on both sides of the tower as shown in Figure A-1.

 - 3.3 Nonpower Line Interference - If it is suspected that the emission measured is other than from the power line, readings at several frequencies should be taken at several distances greater than 50 feet, perpendicular to this power line. Typical measurements of interference from power lines show a $1/d^3$, $1/d^2$, or $1/d$ relationship with distance from the line, depending on the frequency.

X ANTENNA LOCATIONS

MEASURE ON BOTH SIDES OF TOWER
AT VOLTAGES FROM 70 - 1000 kV

MEASURE ON ONE SIDE OF TOWER
OR POLE AT VOLTAGES FROM 0 - 70 kV

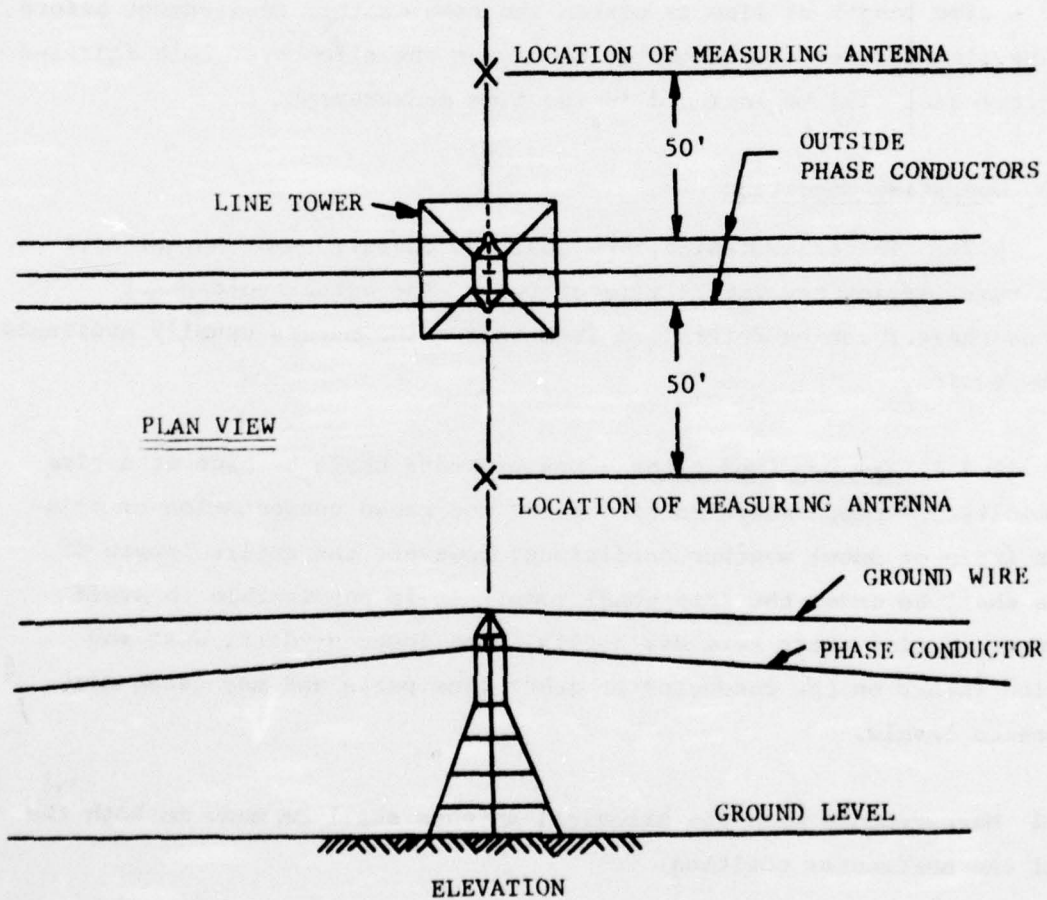

Figure A-1. Antenna Locations for Power Line Interference Measurements.

4. Notes

4.1 Antenna Isolation - Proximity effects from nearby objects shall be avoided when making measurements. Measurement of radiated broadband impulse-type interference will be influenced by conducting objects, including personnel, in close proximity to the antenna.

4.2 Monitoring - Meters, either indicating or graphic, should be installed near the measurement location to monitor the line interference while measurements are being made. Readings should be repeated if the monitor shows greater than 6 dB changes. It may be necessary to determine that the entire length of line is within the same weather environment before proceeding with further measurements; otherwise the effects of both fair and foul weather data will be included in the line measurement.

4.3 Operating Condition

4.3.1 The transmission line shall be operated near normal operating voltage, during the entire time of test. The actual voltage or variations thereof can be determined from indicating meters usually available at a sub-station.

4.3.2 Weather Conditions - Measurements shall be made at a time when humidity and temperature conditions do not cause condensation of moisture wet (rain or snow) weather conditions; however, the entire length of the line shall be under the same conditions. It is permissible to avoid measurements during short term dry spells, when insects, dirt, dust and vegetation gather on the conductor or other line parts and may cause high interference levels.

4.4 Measurements with the biconical antenna shall be made in both the vertical and horizontal position.

4.5 Measuring antenna shall be positioned on a tripod one meter above ground.

4.6 Emission limits shall be as shown in Figure A-2.

Figure A-2. Emission Limits for Overhead Power Lines.

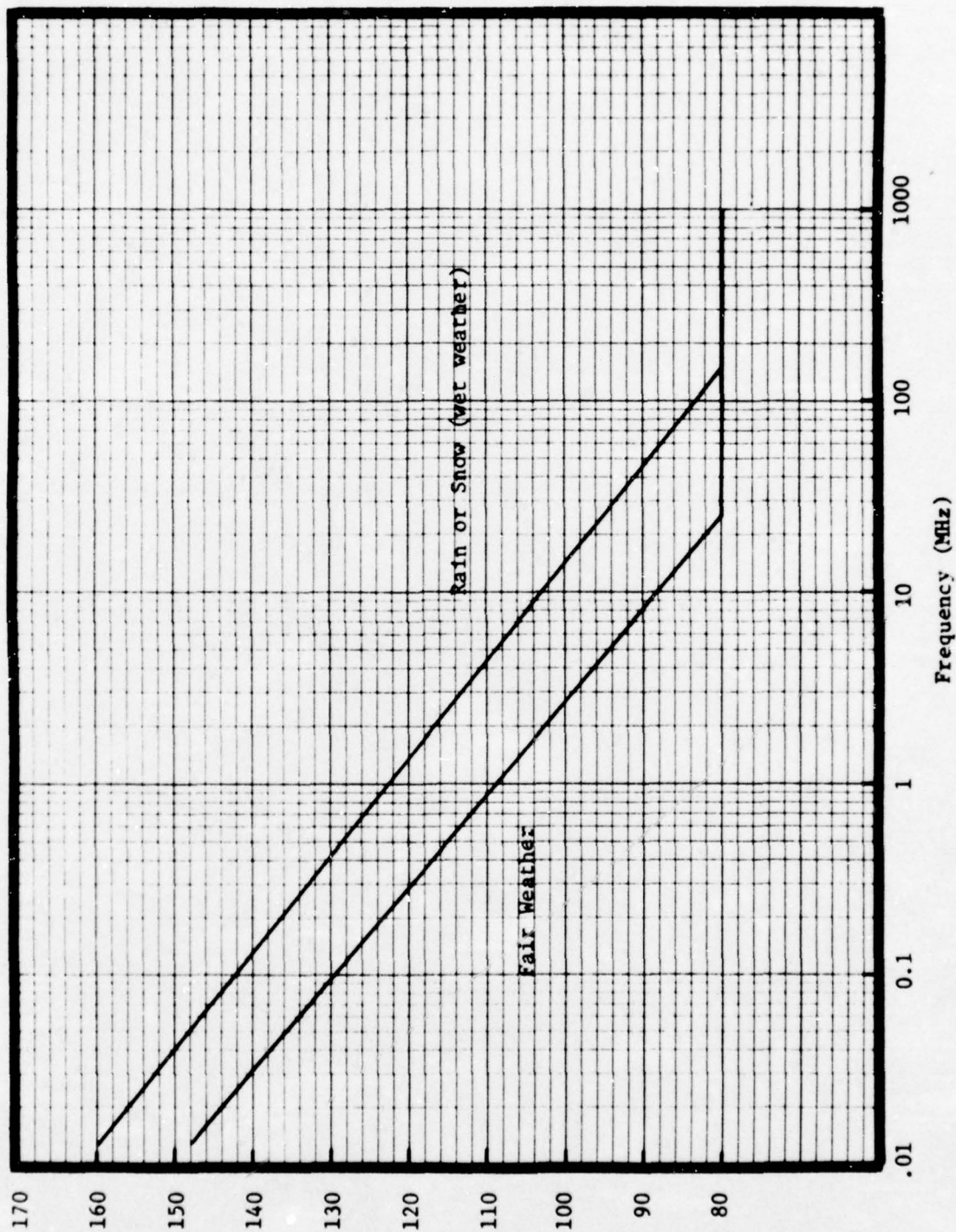

APPENDIX B

FAA Radiated Notice to MIL-STD-461A

MIL-STD-461A
FAA Notice 1R

FAA STANDARD
RADIATED ELECTROMAGNETIC INTERFERENCE CHARACTERISTICS
REQUIREMENTS FOR EQUIPMENT

This notice is applicable to all FAA procurements. It should be filed in front of MIL-STD-461A, dated 1 August 1968, and supersedes that document in those areas detailed herein.

TO ALL HOLDERS OF MIL-STD-461A:

Make the following changes.

1. Page i - In title delete "Military" and substitute "FAA".
Delete DoD seal and substitute FAA seal.
2. Page ii - Delete "Department of Defense" and substitute "Federal Aviation Administration".
In title delete zip code 20360 and substitute zip code 20590.
Delete paragraphs 1 and 2 and substitute:
 1. This standard is mandatory for use by all Departments and Agencies of the FAA.
 2. Recommended corrections, additions, or deletions should be addressed to Systems Research and Development Service, Code 350, Federal Aviation Administration, Washington, DC 20590.
3. Page iii - In second paragraph, delete "military" and substitute "FAA".
4. Pages iv through vi - Delete and substitute the attached Table of Contents, List of Figures, and List of Tables.
5. Paragraph 1.1 - In the third and fourth lines, delete "for general or multi-service procurements and single service procurements" and substitute "for FAA procurement".
6. Paragraph 1.1.2 - Delete "MIL-STD-462" and substitute "MIL-STD-462, FAA Notice 1R".

7. Paragraph 2.1 - Add the following documents:

PROGRAM PLANS

FAA-RD-76-75 - Electromagnetic Compatibility Program Plan

STANDARDS

MIL-STD-461A, FAA Notice 1C - Conducted Electromagnetic Interference Characteristics, Requirements for Equipment

MIL-STD-462, FAA Notice 1R - Electromagnetic Interference Characteristics, Measurement of

8. Paragraph 3. Delete and substitute the following paragraphs:

3. DEFINITIONS

3.1 Definitions. - The terms used in this standard and not defined herein are defined in MIL-STD-463.

3.1.1 Equipment. - For the purpose of this standard an equipment is defined as any electrical, electronic, or electromechanical device intended to operate as an individual unit and performing a singular function.

3.1.2 Subsystem. - A subsystem is defined as an assemblage of devices and/or equipments designed and integrated to function as a single entity but wherein any device or equipment is not required to function individually as defined in paragraph 3.1.1.

3.1.3 System. - A system is a collection of equipments and/or subsystems integrated as a functional whole and intended for installation in fixed locations.

9. Paragraph 4.1.2 - Delete and substitute:

4.1.2 FAA Furnished Equipment. - Equipment furnished by the FAA to a contractor may, unless the test data is furnished by the FAA, require additional testing by the contractor for conformance to the equipment item class and limit requirements. Application of suppression measures to meet the requirements of this standard shall be detailed in the Control Plan.

10. Paragraph 4.1.3.2 - Delete and substitute:
4.1.3.2 When Government approved equipments are selected for use with or to become a part of any FAA equipment configuration, the requirements of 4.1.3.1 apply.
11. Paragraph 4.1.3.3 - Delete without replacement.
12. Paragraph 4.1.4 - Delete the phrase "shall meet the appropriate requirements specified in Appendix A of this standard" and substitute "shall meet the requirements of this standard. Any deviation from the application of these test requirements must be submitted for evaluation and approval by the FAA."
13. Paragraph 4.1.6 - Delete and substitute:
4.1.6 Short-Duration Interference. - Short-duration interference, such as produced by switching transients, is not exempt from the requirements of this standard unless specifically indicated in the individual equipment specification.
14. Paragraph 4.2 - Delete and substitute:
4.2 Interference Control Plan. - A detailed Control Plan as described in the FAA-RD-76-75 shall be submitted to the FAA. This Control Plan shall outline the interference control or reduction program, the engineering design procedures and proposed techniques that will be used to determine conformance with the requirements of this standard and that will enable the equipment to perform its operational function within its specified design parameters without adversely affecting or being affected by nearby equipments, subsystems, or systems.
15. Paragraph 4.2.1 - Delete without replacement.
16. Table I - Delete and substitute the attached Table I.
17. Table II - Delete and substitute the attached Table II.
18. Paragraph 4.2.1.1 through Paragraph 4.2.1.7 - Delete without replacement.

19. Paragraph 4.3 - Delete and substitute:
 - 4.3 EMI/EMC Test Plan. - A Test Plan as described in the FAA-RD-76-75 shall be submitted and approved before the start of formal testing. The Test Plan shall detail the means of implementation and application of the typical test procedures (depicted in MIL-STD-462, FAA Notice 1R) that will be performed to verify compliance with the applicable requirements of this standard.
20. Paragraph 4.4 - Delete and substitute:
 - 4.4 Test Report. - A report presenting the results of the tests described in the Test Plan shall be submitted to the FAA. The contents and the format of this report shall be as described in the FAA-RD-76-75
21. Paragraph 4.4.1 through Paragraph 4.4.3 - Delete without replacement.
22. Paragraph 5 - Delete and substitute:
 5. MEASURING EQUIPMENT. - A list of suggested measuring equipments and their characteristics, characteristics of the required antennas and their pertinent drawings, and procedures for verification of these characteristics for FAA approval are presented in the measuring equipment paragraphs of MIL-STD-462, FAA Notice 1R.
23. Paragraph 5.1 through Paragraph 5.8.2 - Delete without replacement. Refer to the measuring equipment paragraphs of MIL-STD-462, FAA Notice 1R.
24. Paragraph 6.1 through Paragraph 6.10.2 - Delete without replacement. Refer to the conducted test limits in MIL-STD-461A, FAA Notice 1C.
25. Paragraph 6.11 - Delete without replacement.
26. Paragraph 6.12.1 - Delete "in excess of the values shown in Figure 21" and substitute "in excess of 60 dB μ V/m".
27. Paragraph 6.12.2 and 6.12.3 - Delete and substitute:
 - 6.12.2 Broadband E-field emissions in the required frequency range shall not be generated and radiated in excess of the values shown in Figure 22.

6.12.3 In the frequency range of 30 to 200 MHz, the limit shall be met for both horizontally and vertically polarized waves.

28. Paragraph 6.14 - Delete without replacement.
29. Paragraph 6.15 - In the first sentence delete "1000 MHz" and substitute "400 MHz".

In the second line, delete "classes IIIA and IIIB items" and substitute "Class IV items".

Delete the last sentence without replacement.

30. Paragraph 6.16 through Paragraph 6.18 - Delete without replacement.
31. Paragraph 6.19 - Delete "(T)" without replacement.
32. Page 15 - Delete Paragraphs 7. and 7.1, Custodians, Review Activities, User Activities, and Preparing Activity without replacement.
33. Figure 1A through Figure 15 - Delete without replacement. Refer to related Figures in MIL-STD-461A, FAA Notice 1C.
34. Figure 16 - Delete and substitute the attached Figure 16.
35. Figure 17 through Figure 20 - Delete without replacement. Refer to related figures in MIL-STD-461A, FAA Notice 1C.
36. Figure 21 - Delete without replacement.
37. Figure 22 - Delete and substitute the attached Figure 22.
38. Figure 23 through Figure 24 - Delete without replacement.
39. Appendix A - Delete without replacement.

TABLE OF CONTENTS

	<u>Page</u>
Paragraph 1. SCOPE	1
1.1 Scope.	1
1.2 Units.	1
2. REFERENCED DOCUMENTS.	1
3. DEFINITIONSB-3
3.1 Definitions.B-3
3.1.1 Equipment.B-3
3.1.2 Subsystem.B-3
3.1.3 SystemB-3
4. GENERAL REQUIREMENTS.	2
4.1 Application of Standard.	2
4.1.1 Equipment.	2
4.1.2 FAA Furnished Equipment.B-3
4.1.3 Commercial Off-the-Shelf Equipment	2
4.1.4 Reprocurements of Equipments Designed to Superseded DocumentsB-4
4.1.5 Other EMI Requirements	2
4.1.6 Short-Duration Interference.B-4
4.2 Interference Control Plan.B-4
4.3 EMI/EMC Test Plan.B-5
4.4 Test Report.B-5
5. MEASURING EQUIPMENTB-5
6. LIMITS.	13
6.12 Limits for RE02B-5
6.13 Limit for RE03.	14
6.15 Limit for RE05.	14
6.19 Limit for RS03 and RS04	14

LIST OF FIGURES

	<u>Page</u>
Figure 16. Transmitter Spurious and Harmonic Emission Limits for.	B-12
22. Broadband Emission Limits for Test Methods RE02 and RE05	B-13

LIST OF TABLES

	<u>Page</u>
Table I. EQUIPMENT CLASSIFICATION.	B-10
II. TEST METHODS AS A FUNCTION OF FREQUENCY RANGE AND EQUIPMENT CLASSIFICATION	B-11

TABLE I
EQUIPMENT CLASSIFICATION

Class Designation	Equipment Description
I	<p>Communication-Electronic (C-E) Equipments</p> <p>All electronic equipments which in their operation transmit, receive, generate, store, or process information. Included in this classification are transmitters with antennas, receivers with antennas, transceivers with antennas, regulated output amplifiers, backup emergency communication equipment, inner and outer markers, plan view displays, etc.</p>
II	<p>Electronic Equipments</p> <p>All electronic equipments which are not Class I. Included in this classification are oscilloscopes, signal sources, test sets, counters, spectrum analyzers, time code generators, radio frequency monitors, etc.</p>
III	<p>Electro-Mechanical Equipments</p> <p>All equipments which in their operation have both a mechanical and electrical/electronic function. Included in this classification are teletype machines, portable electrical tools, repair shop equipment, kitchen and/or lounge equipment, office devices, etc.</p>
IV	<p>Motor Vehicles and Engine-Driven Equipments</p>
IVA	<p>All motor-driven vehicles which in their operation may interrupt normal operations via ignition system radiation. Included are tug vehicles at airports, maintenance and installation vehicles used at remote C-E sites, etc.</p>
IVB	<p>All engine-driven equipments which in their operation may emit interference signals from an ignition system or commutator. Included are gasoline engines, motor-generators, etc.</p>

TABLE II

TEST METHODS AS A FUNCTION OF FREQUENCY RANGE AND EQUIPMENT CLASSIFICATION

Test Method	Test Description	Frequency Range	Equipment Class	Antennas
RE02	Radiated Emissions, Electric Fields	14 kHz to 10 GHz	I, II, and III	14 kHz to 30 MHz: one 41 inch monopole antenna with tuning network 30 to 400 MHz: one biconical antenna and one planar log spiral antenna 400 MHz to 10 GHz: four hooded planar log-spiral antennas
RS03	Radiated Susceptibility, Electric Fields	30 MHz to 10 GHz	I, II, and III	30 MHz to 400 MHz: one biconical antenna and one planar log-spiral antenna 400 MHz to 10 GHz: four hooded planar log-spiral antennas
(T)RS04	Radiated Susceptibility, Electric Fields	14 kHz to 30 MHz	I, II, and III	Either long wire antenna or parallel plate line
RE03	Spurious and Harmonic Emissions	14 kHz to 40 GHz	I*	14 kHz to 30 MHz: one 41 inch monopole antenna with tuning network 30 MHz to 400 MHz: one biconical antenna and one planar log-spiral antenna 400 MHz to 10 GHz: four hooded planar log-spiral antennas 10 to 40 GHz: three horn antennas with dish reflectors
RE05	Radiated Emissions,	150 kHz to 400 MHz	IV	150 kHz to 30 MHz: one 41 inch monopole antenna with tuning network 30 to 200 MHz: one biconical antenna 200 to 400 MHz: one planar log-spiral antenna

*Transmitters Only

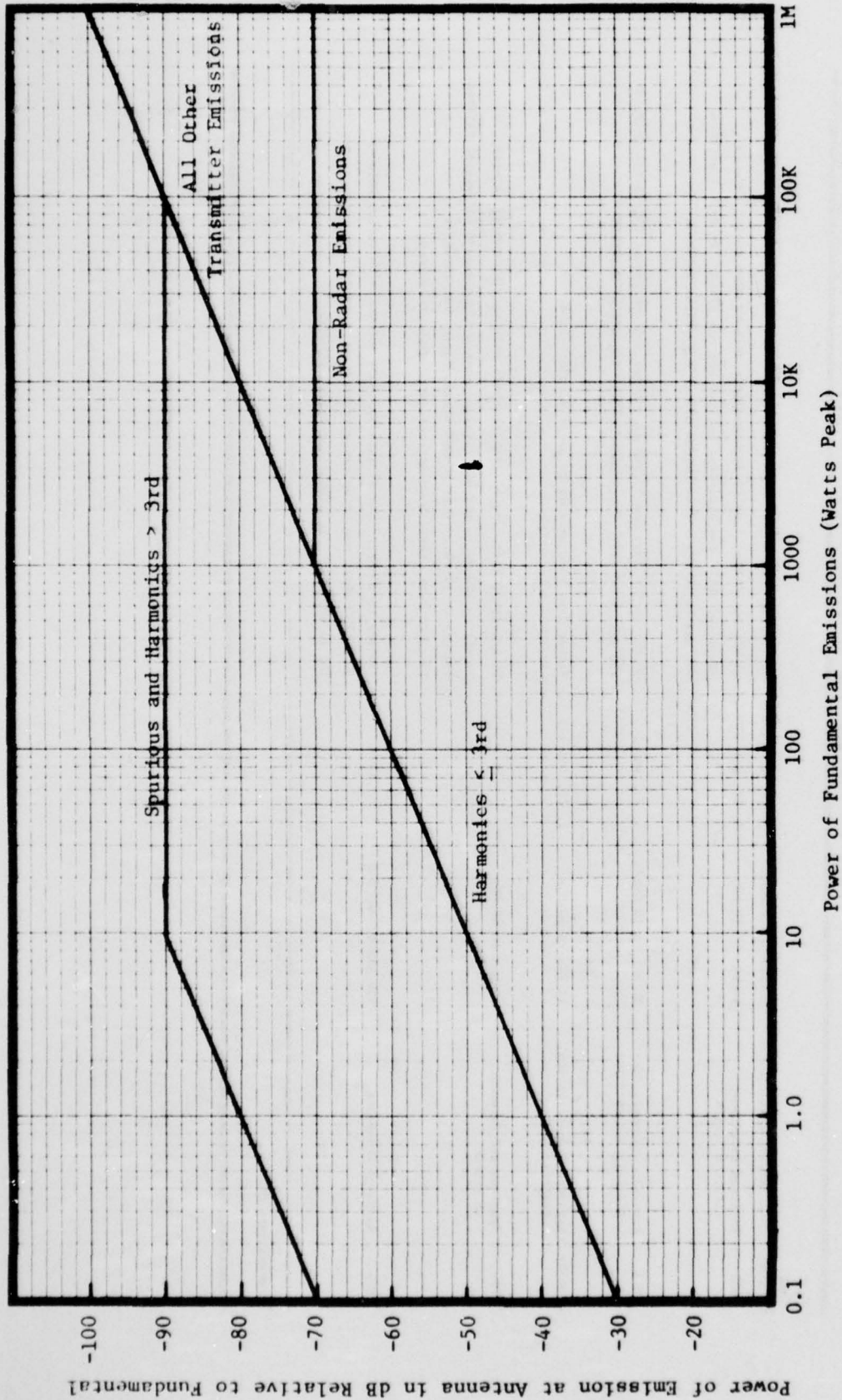

Figure 16. Transmitter Spurious and Harmonic Emission Limits.

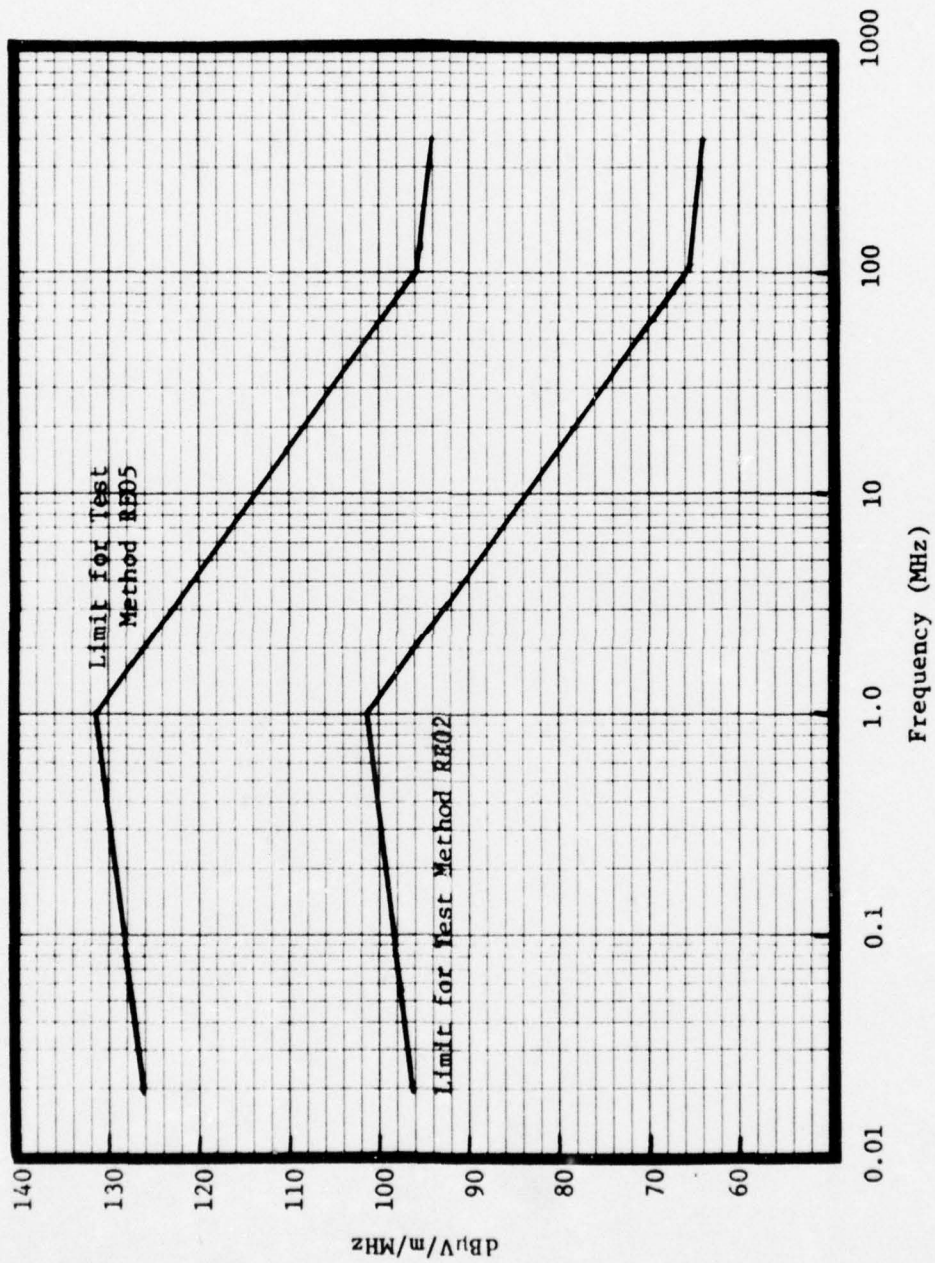

Figure 22. Broadband Emission Limits for Test Methods RE02 and RE05.

14-00000
FAA Notice 1R
14 March 1978

APPENDIX C

FAA Radiated Notice to MIL-STD-462

**MIL-STD-462
FAA Notice 1R**

FAA STANDARD
RADIATED ELECTROMAGNETIC INTERFERENCE
CHARACTERISTICS, MEASUREMENT OF

This notice is applicable to all FAA procurements. It should be filed in front of MIL-STD-462, dated 31 July 1967, and supersedes that document in those areas detailed herein.

TO ALL HOLDERS OF MIL-STD-462:

Make the following changes.

1. Page i - Delete "Military" and substitute "FAA".
Delete DoD seal and substitute FAA seal.
2. Page ii - Delete "31 July 1965" in upper left corner of page and substitute "31 July 1967".
Delete "Department of Defense" and substitute "Federal Aviation Administration".
Delete zip code "20301" and substitute zip code "20590".
Delete "MIL-STD-426" and substitute "MIL-STD-462".
Delete paragraphs 1 and 2 and substitute:
 1. This standard is mandatory for use by all Departments and Agencies of the FAA.
 2. Recommended corrections, additions, or deletions should be addressed to the Systems Research and Development Service, Code 350, Federal Aviation Administration, Washington, DC 20590.
3. Page iii - Delete the entire Table of Contents, List of Figures, and List of Tables and substitute the attached Table of Contents, List of Figures, and List of Tables.
4. Paragraph 1.1 - Delete "MIL-STD-461" and substitute "MIL-STD-461A, FAA Notice 1R".

5. Paragraph 1.2.1 - Delete "C = Conducted" without replacement.
Delete subparagraphs (a) and (c) without replacement.
6. Paragraph 1.2.2 - Delete without replacement.
7. Paragraph 1.2.3 - Delete second and third sentences without replacement.
8. Paragraph 2.1 - Add the following documents:

PROGRAM PLANS

FAA-RD-76-75 Electromagnetic Compatibility Program Plan

SPECIFICATIONS

EL-CD-6003-0009A Electromagnetic Interference Measurement
Instrumentation, Characteristics for

STANDARDS

MIL-C-45662 Calibration of Standards

MIL-STD-461A, FAA Electromagnetic Interference Characteristics,
Notice 1R Requirement for Equipments

MIL-STD-220A Method of Insertion-Loss Measurement

MIL-STD-285 Attenuation Measurements for Enclosures,
Electromagnetic Shielding, for Electronic
Test Purposes, Method of

DRAWINGS

ES-F-201286 Antenna, Biconical 30 MHz to 300 MHz,
less Balun

ES-DL-176439 Bifalar Balun, 30 MHz to 300 MHz

62J4040 Antenna, Conical Log Spiral, 200 to 1000 MHz

ES-DL-201090 and Antennas, Microwave 12-40 GHz Detail Assembly
Drawings thereto

9. Paragraph 3.1 - Delete "MIL-STD-463" and substitute "MIL-STD-461A, FAA Notice 1R and MIL-STD-463".
10. Paragraph 4.1 - Delete and substitute:
 - 4.1 General Requirements. - General requirements pertaining to the application of this standard and the applicable test limits are specified in MIL-STD-461A, FAA Notice 1R. The test procedures contained in

this standard shall be used in complying with MIL-STD-461A, FAA Notice 1R, measurement requirements and in preparing the EMI Test Plan.

11. Paragraph 4.2.1.1 - Delete and substitute:

4.2.1.1 Ambient Electromagnetic Level. - During testing the ambient electromagnetic field level measured with the test item de-energized shall be at least 6 dB below the allowable specified limit. Precautions for avoiding ambient signals generated by the test equipment shall be observed.

12. Paragraph 4.2.1.2 - Delete and substitute:

4.2.1.2 Ground Plane. - A circular copper or brass ground plane (solid plate) that has a minimum thickness of 0.158 centimeters for copper or 0.317 centimeters for brass and a minimum diameter of 122 centimeters shall be used. The ground plane shall be bonded to the shielded enclosure such that the dc resistance is no greater than 2.5 milliohms.

13. Paragraph 4.2.1.6 - Delete and substitute:

4.2.1.6 RF Absorber Material. - RF absorber material shall be used in shielded enclosures during EMI tests in accordance with the requirements of the specific test methods in Paragraph 5 of this standard.

14. Add the following new paragraphs:

4.2.1.7 Test Site.

4.2.1.7.1 Shielded Enclosures. - Shielded enclosures shall be of sufficient size to adequately accept the test item without sacrificing test accuracy or requiring deviation from the methods specified herein. In the case of measurements using hooded antennas, this requires an enclosure with minimum dimensions of 8 x 12 x 8 feet. Shielding and filtering characteristics shall meet the following minimum requirements:

(a) Shielding effectiveness to electric fields and plane waves, as measured in accordance with MIL-STD-285, shall be at least 80 dB over the frequency range of test.

(b) Power line filtering must be included and shall have an attenuation to frequencies above 10 kHz of at least 80 dB as measured in accordance with MIL-STD-220A.

4.2.1.7.2 Open Areas.- Open field sites may be used when sufficiently large shielded enclosures are not available or when the nature of the equipment tested precludes their usage. The ambient requirements of Paragraph 4.2.1.1 must be observed.

15. Paragraph 4.2.2.4.2 - Delete last sentence.
16. Paragraph 4.2.3 through Paragraph 4.2.3.6 - Delete and substitute the following paragraphs. (Refer to Paragraph 4.2.3.3 through Paragraph 4.2.3.8.)

4.2.3 Measuring Equipment.- This section describes the test equipment used in the test methods contained in this standard.

4.2.3.1 Test Antennas.- Table I lists antennas which shall be used for performing radiated emission (RE) and radiated susceptibility (RS) measurements. Where antenna frequency ranges overlap, either may be used, receiver sensitivity permitting. Specification EL-CD-6003-0009A states requirements and testing techniques for antennas used in testing to this standard; antenna factors shall be determined in accordance with the testing techniques of that specification. The antenna factors referenced in Table I and given in Figures 1, 2, and 3 are the maximum factors for the antennas. The antenna factors shall be determined by the antenna manufacturer for each antenna and furnished with the antenna.

4.2.3.1.1 Monopole Test Antenna Counterpoise.- The monopole test antenna counterpoise shall be referenced to the shielded enclosure. This involves bonding the counterpoise to the enclosure via a strap the same width as the counterpoise. Necessary precautions shall be taken to assure low impedance bonding connections.

4.2.3.2 Other Equipment Characteristics.- Requirements for measuring equipment characteristics are contained in Specification EL-CD-6003-0009A along with the technique for measurement of these characteristics.

TABLE I

MEASUREMENT ANTENNAS

Antenna Identification Nomenclature	Frequency Range	Applicability			Maximum Antenna Factor Figure Number	Military Drawing Number	Physical Description Reference
		RE	RS	RE03			
41-inch Monopole and Matching Network	14 kHz to 30 MHz	X		X	Equipment Manual		
Parallel Line Plate	14 kHz to 30 MHz		X				See drawings accompanying test procedure
Long Wire Antenna	14 kHz to 30 MHz		X				See drawings accompanying test procedure
Biconical Antenna W/T-1 Balun	20 MHz to 200 MHz	X	X	X	Figure 1	ES-F-201286	See Military Drawing
Biconical Antenna W/Bi falar Balun	30 MHz to 300 MHz	X	X	X	Figure 2	ES-DL-176 439	See Military Drawing
Planar Logarithmic Spiral	200 MHz to 400 MHz	X	X	X			
Conical Logarithmic Spiral	200 MHz to 400 MHz	X	X	X	Figure 3	62J4040	See Military Drawing
12-inch Hooded Planar Logarithmic Spiral	400 MHz to 1 GHz	X	X	X			
4-inch Hooded Planar Logarithmic Spiral	1 GHz to 2 GHz	X	X	X			See Figure 4
2-inch Hooded Planar Logarithmic Spiral	2 GHz to 6 GHz	X	X	X			See Figure 4
1-inch Hooded Planar Logarithmic Spiral	6 GHz to 12 GHz	X	X	X			See Figure 4

(Continued)

TABLE I (Continued)

MEASUREMENT ANTENNAS

Identification Nomenclature	Frequency Range	Applicability			Maximum Antenna Factor Figure Number	Military Drawing Number	Physical Description Reference
		RE	RS	RE03			
Horn feeding an 18-inch Dish	12 GHz to 18 GHz			X		ES-DL- 201090	See Military Drawing
Horn feeding a 12-inch Dish	18 GHz to 26 GHz			X			
Horn feeding a 12-inch Dish	26 GHz to 40 GHz						

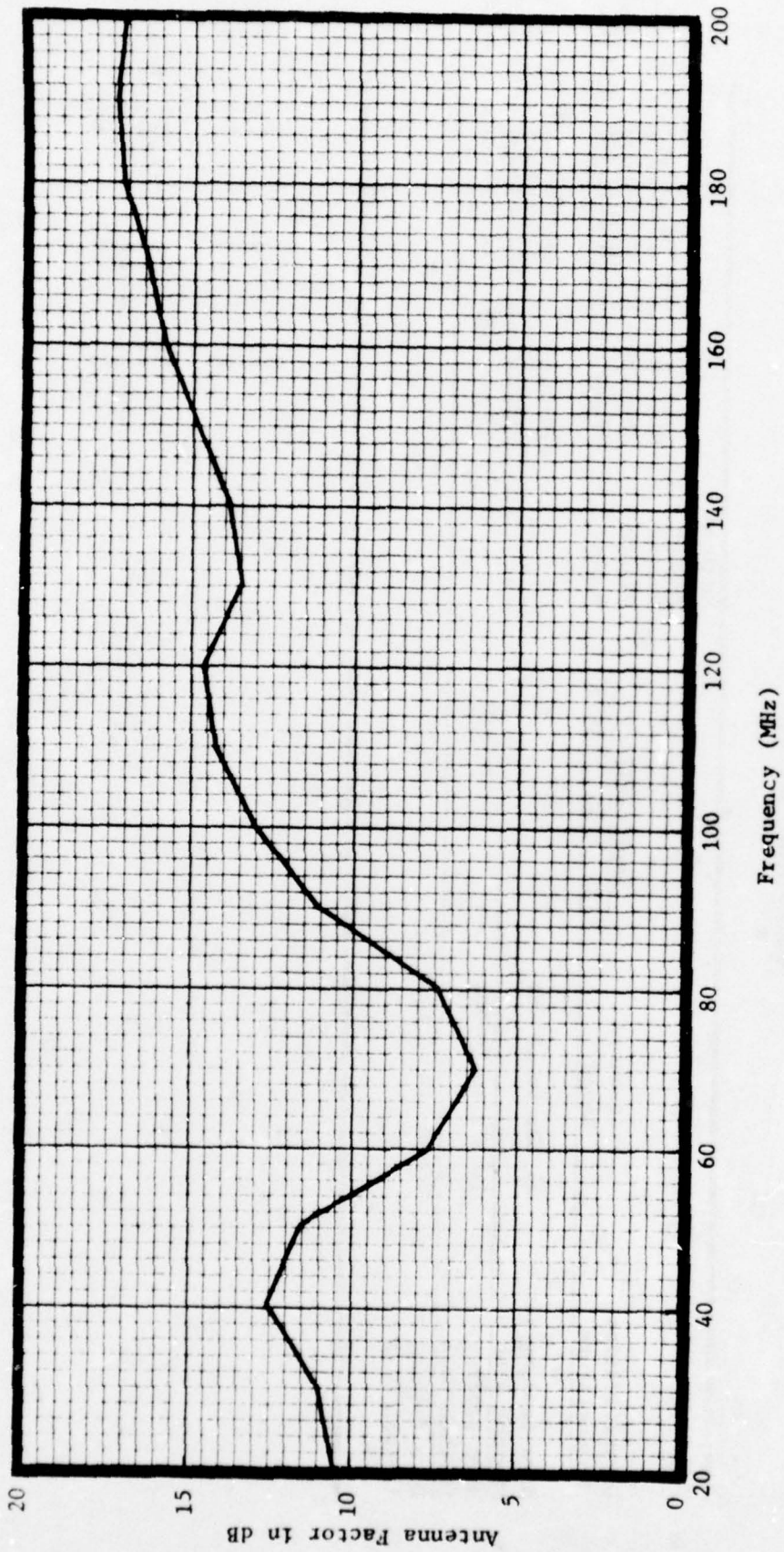

Figure 1. Antenna Factor for Biconical Antenna (to be added to Receiver Meter Reading in dB.V/m). Dwg. ES-F-201286

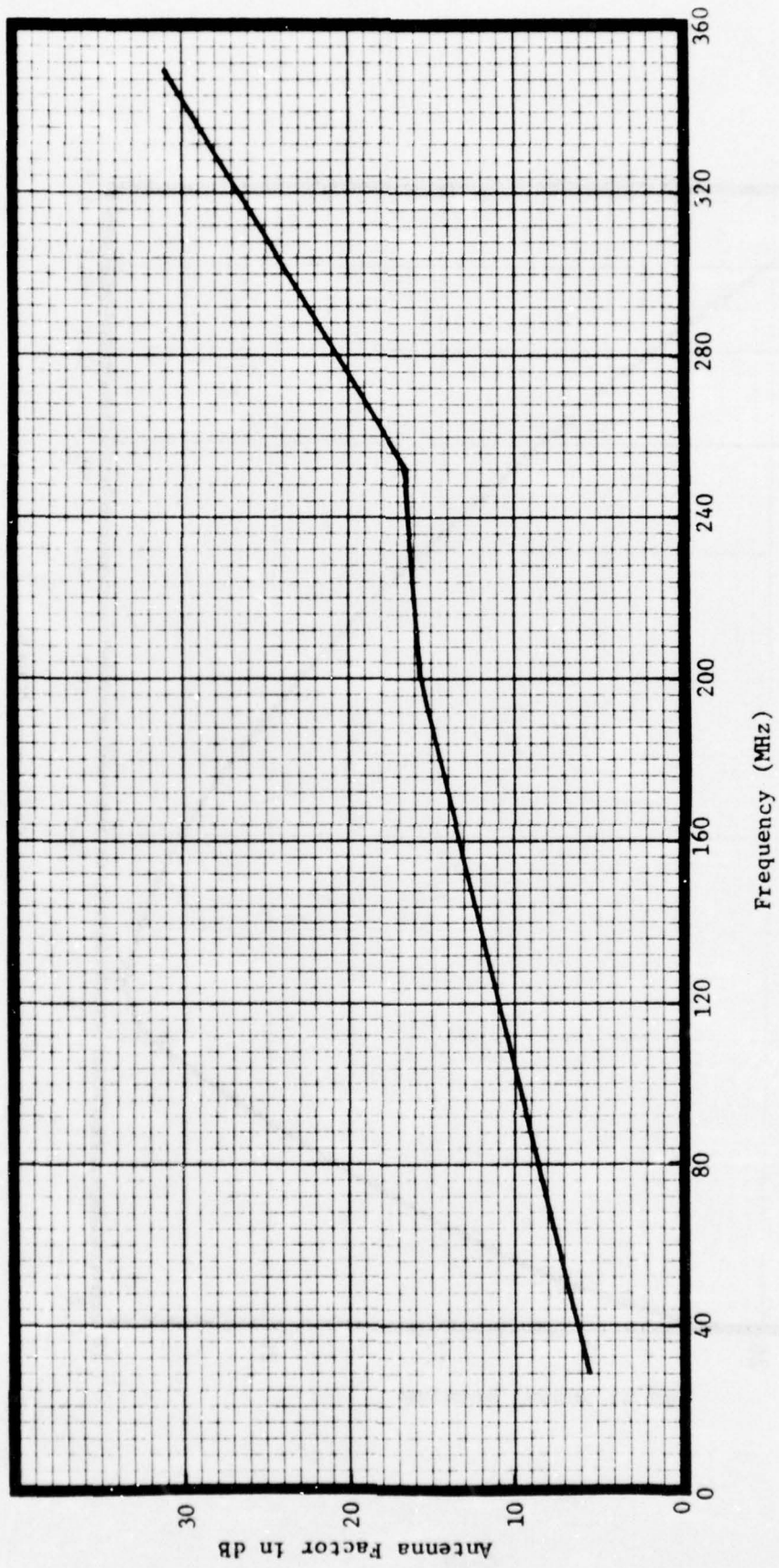

Figure 2. Biconical Antenna with Bifalar Balun per ES-DL-176439 and ES-F-201286.

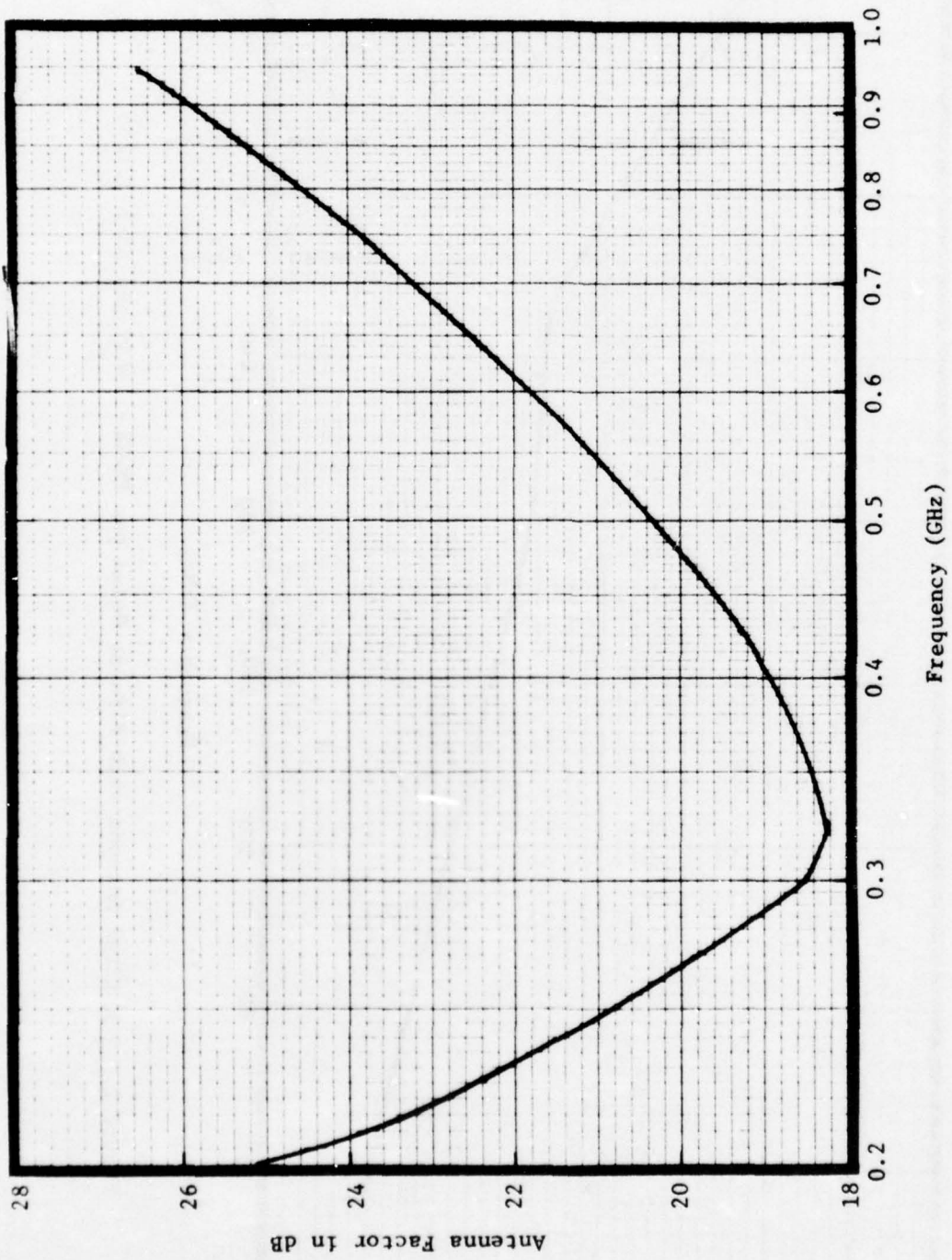
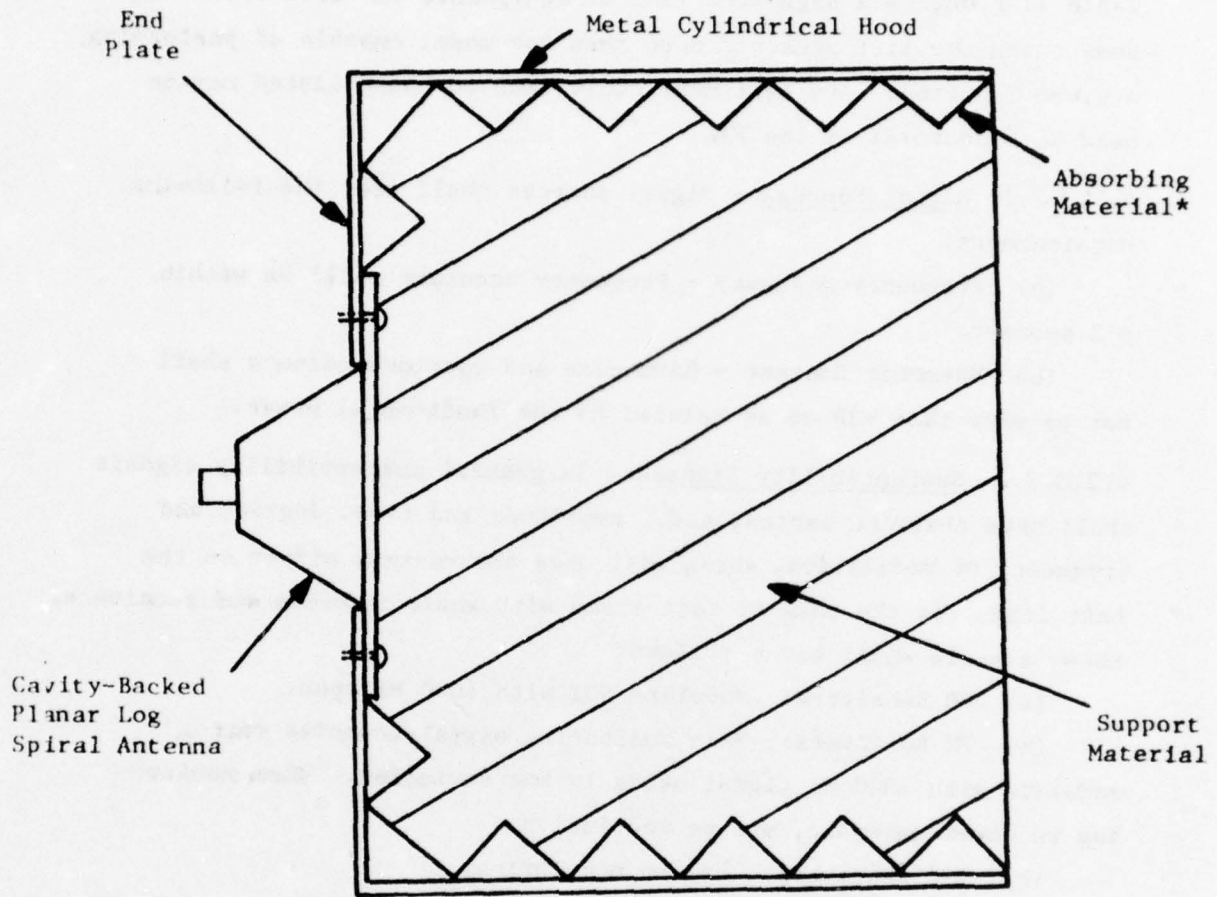

Figure 3. Antenna Factor for Conical Log Spiral. (To be added to Receiver reading in dB_V to Convert to Field Intensity in dB_V/m.)



<u>Frequency Range</u>	<u>Antenna**</u>	<u>Hood Length</u>	<u>Hood Inside Diameter</u>
6.0 to 10.0 GHz	AEL Model ASN 111A	1.0 inch	2.0 inches
2.0 to 6.0 GHz	AEL Model ASN 118A	2.0 inches	4.0 inches
1.0 to 2.0 GHz	AEL Model ASN 116A	4.0 inches	12.0 inches
0.4 to 1.0 GHz	AEL Model ASN 117A	12.0 inches	24.0 inches

*Absorbing Material shall be Emerson and Cuming Type NZ-1 or equivalent.

**Antenna model numbers correspond to antennas available from American Electronics Laboratory, Lansdale, PA 19446. These antennas or equivalent planar log spirals shall be used.

Figure 4. Hooded Antenna Design Features and Characteristics.

Table II presents a suggested list of equipments for each test. In some cases the list presents more than one model capable of performing a given function. Any equipment equivalent to those listed may be used with approval of the FAA.

4.2.3.2.1 Signal Sources. - Signal sources shall meet the following requirements:

(a) Frequency Accuracy - Frequency accuracy shall be within ± 2 percent.

(b) Harmonic Content - Harmonics and spurious outputs shall not be more than -30 dB as related to the fundamental power.

4.2.3.2.2 Susceptibility Signals. - In general susceptibility signals shall have characteristics, e.g., amplitude and type, degree, and frequency of modulation, which will have the maximum effect on the test item. In the case of test items with audio channels and receivers, these signals shall be as follows:

(a) AM Receivers: Modulate 50% with 1000 Hz tone.

(b) FM Receivers: When monitoring signal-to-noise ratio, modulate with 1000 Hz signal using 10 kHz deviation. When monitoring receiver quieting, use no modulation.

(c) SSB Receivers: Use no modulation.

(d) Other Equipments: Same as for AM receivers.

For test items with video channels other than receivers, modulate the susceptibility signal 90 to 100 percent with a pulse of duration $2/BW$ and a repetition rate equal to $BW/1000$, where BW is the video bandwidth. Susceptibility signals for digital test items shall use pulse modulation with a duration and repetition rate equal to that used in the digital equipment. Non-tuned test items shall use susceptibility signals that are modulated 50 percent with at 1000 Hz tone. The rationale for selecting these signals shall be presented in the Test Plan.

4.2.3.3 Use of Measuring Equipment. - All equipment shall be operated as prescribed by the applicable instruction manuals unless otherwise

TABLE II

SUGGESTED TEST EQUIPMENT

Equipment	Manufacturers	Model	Frequency Range	RE02	RE03	RE05	RS03	RS04
Spectrum Analyzers	Singer-Metrics	SPA-3000	10 MHz to 40 GHz		•			
	Hewlett Packard	8551B	10 MHz to 40 GHz		•			
	Hewlett Packard	8552A 8553L	1 kHz to 110 MHz		•			
Amplifiers	Instruments for Industry (IFI)	5000	10 kHz to 220 MHz				•	
	Microdot	248A	200 MHz to 575 MHz				•	
	Microdot	296	500 MHz to 1000 MHz				•	
	Servo	2000	1 GHz to 18 GHz				•	
Power Oscillators	Airborne Inst. Lab.	125	200 MHz to 2 GHz				•	
	Microdot	1927	2 MHz to 2.5 GHz				•	
Spectrum Display Units	Electro-Metrics	SPD-125				•		
	Electro-Magnetics	"Adapter"				•		
EMI Meters	Singer-Metrics	NF105A	14 kHz to 1 GHz	•	•	•	•	•
	Singer-Metrics	EMA-910-10	1 GHz to 22 GHz	•	•		•	
	Fairchild Electro-Metrics	EMC-25R	14 kHz to 1 GHz	•	•	•	•	•
	Stoddard	NM62A	1 GHz to 10 GHz	•	•		•	
Automated Scan Systems	Fairchild Electro-Metrics	FSS-250	14 kHz to 1 GHz	•	•	•	•	
	Weinschel Engineering	130A	20 Hz to 1 GHz	•	•	•	•	
Line Impedance Stabilization Networks	Filtron	FSQ-70256	2 MHz to 50 MHz	•				

(Continued)

TABLE II (Continued)

SUGGESTED TEST EQUIPMENT

Equipment	Manufacturers	Model	Frequency Range	RE02	RE03	RE05	RS03	RS04
Yig Filters	Watkins Johnson	581-584	1 GHz to 12 GHz		•			
Frequency Counters	Systron Donner	1037B			•			
Pin Diode Modulator	Hewlett Packard	8730 Series	400 MHz to 12.4 GHz				•	
Balanced Mixers	Hewlett Packard	10514	200 kHz to 500 MHz				•	
	Hewlett Packard	10534	50 kHz to 150 MHz				•	
VTVM	Hewlett Packard	410C	20 Hz to 200 MHz				•	•

specified herein. This standard takes precedence in the event of conflict with instruction manuals or other such documents.

4.2.3.4 Equipment Warm-Up Time. - Prior to commencing data collection, the measuring equipment shall have been energized for a period of time adequate to allow parameter stabilization. If the operational manual does not specify a specific warm-up time, a period of one hour shall be observed.

4.2.3.5 Detector Function. - A peak detector shall be used for all measurements required by MIL-STD-461A, FAA Notice 1R; however, for narrowband measurements, the average rms function may be used if authorized by the FAA. Substitution generator output levels shall be corrected when the detector output and the signal generator output calibration are different functions of a sine wave, i.e., peak, average, or rms.

4.2.3.6 Grounding of Measurement Equipment. - The EMI measurement instrumentation shall be bonded to the shielded enclosure to provide a ground reference plane.

4.2.3.7 Monitoring of Measuring Equipment. - The IF output of the EMI meter shall be monitored with a device that gives an amplitude versus frequency presentation on a cathode ray tube. This monitor is used to obtain information on the characteristics of the signals being measured. The measuring equipment shall also be monitored with headphones or a speaker.

4.2.3.8 Identification of Spurious Responses in Measuring Equipment. - The measurement equipment shall be checked for spurious responses. False data caused by such spurious responses shall be so identified on the X-Y recordings or data sheets.

4.2.3.9 Calibration of Measuring Equipment. - Measuring instruments and accessories used in determining compliance with this standard shall be calibrated under an approved program in accordance with MIL-C-45662. The calibration program document required by MIL-C-45662 shall be submitted for FAA approval as part of the Test Plan.

See Specification EL-CD-6003-0009A for calibration methods for impulse generators. Calibration of measurement equipment and accessories, impulse generators, and other equipments shall be verified at any time upon request of witnessing officials or authorized representatives of the FAA.

4.2.3.10 Accuracy of Measurements. - All measurements made in accordance with this standard shall have the following accuracies. Proof of such accuracy shall be documented in the Test Report.

(a) Frequency Accuracy - Where specified limits are exceeded in the spurious response and harmonic and spurious emission tests (antenna terminal), the frequency of measurement shall be accurate to within $\pm 1\%$. Since signal generators and EMI meters usually do not offer this accuracy, it will be necessary to employ a frequency counter or other similar standard. All other tests shall be subject to a frequency accuracy of $\pm 2\%$.

(b) Amplitude accuracy shall be $\pm 2\%$ dB.

17. Paragraph 4.2.4 through Paragraph 4.2.4.4 - Delete and substitute:

4.2.4 Positioning of Measurement Antennas. -

4.2.4.1 Each face of the test item shall be probed with a loop or other suitable sensor to determine the localized area producing maximum emission or susceptibility. Probing shall be performed at frequencies known or calculated to represent worst case interference. If no such information is available, probing shall be performed at no less than one frequency for every two octaves over the frequency range of test. The face exhibiting worst case characteristics in any octave or band, provided that a band is not less than two octaves, shall face the test antenna for that portion of the frequency scan. Automatic scan techniques may be used to scan all sides of the test item.

4.2.4.2 When performing radiated emission and susceptibility tests, no point of the antennas shall be less than one meter to the walls and 0.5 meters to the ceiling of the shielded enclosure or obstruction.

4.2.4.3 For radiated emission measurements between 30 and 400 MHz, linearly polarized antennas shall be alternately positioned to measure the vertical and horizontal components of the emission. For radiated susceptibility measurements between 30 and 400 MHz, linearly polarized antennas shall be positioned so as to alternately generate vertical and horizontal fields.

18. Figure 1 - Delete without replacement.
19. Figure 2 - Delete without replacement.
20. Paragraphs 4.2.6 and 4.2.6.1 - Delete and substitute:

4.2.6 Identification of Broadband and Narrowband Emissions. - Identification of broadband and narrowband emissions may be accomplished by use of the monitoring equipment specified in 4.2.3.6 or by observing affects due to switching of bandwidths or detection functions. When switching bandwidths or detector functions, the following tests shall apply:

(a) Test 1: The EMI meter shall be tuned over a range of plus and minus 2 impulse bandwidths around its center frequency. A change in peak response of 3 dB or less indicates a broadband emission. Any change of greater than 3 dB indicates a narrowband emission.

(b) Test 2: Measure the pulse repetition rate of the emission. If the pulse repetition rate is less than or equal to the impulse bandwidth (IBW) of the measuring equipment, it is a broadband emission. If it is greater than IBW, it is a narrowband emission.

Also, an optional differentiation can be made by measuring the pulse repetition rate of the emission. If the pulse repetition rate is less than the rate specified in the following table, it should be considered a broadband emission and should be measured with an instrument having a bandwidth equal to or greater than the value of the specified rate. If the repetition rate is greater than specified below, the emission should be considered narrowband and should be measured with an instrument having a bandwidth less than or equal to the value of the specified repetition rate.

<u>Frequency Range</u>	<u>Repetition Rate</u>
20 kHz - 150 kHz	200 Hz
150 kHz - 30 MHz	5 kHz
30 MHz - 400 MHz	100 kHz
400 MHz - 1000 MHz	300 kHz

4.2.6.1 Pulsed CW Requirements. - The pulse repetition criteria expressed in the foregoing shall apply for pulsed CW up to 100 MHz. Above 100 MHz, pulsed CW emissions shall be compared to narrowband limits; however, bandwidth corrections should be employed to normalize the measurements to 1 MHz bandwidth.

21. Paragraphs 4.2.8 through 4.2.8.2.2 - Delete without replacement.
22. Paragraph 5.1 - In the first line add the word "radiated" before the words "measurement procedures".
23. Paragraph 5.2 - Delete and substitute:

5.2 Table III is an index of the radiated measurement procedures by method number, date, and title.
24. Table I - Delete and substitute the attached Table III.
25. Page 11/12 - Delete without replacement.
26. Method CE01 through CE06 - Delete without replacement. (Refer to MIL-STD-462, FAA Notice 1C.)
27. Method CS01 through CS08 - Delete without replacement. (Refer to MIL-STD-462, FAA Notice 1C.)
28. Method RE01 - Delete without replacement.
29. Method RE02 - Delete and substitute the attached Method RE02.
30. Method RE03 - Delete and substitute the attached Method RE03.
31. Method RE04 - Delete without replacement.
32. Method RE05 - Make the following changes:
 - (a) In the title, delete "1 GHz" and substitute "400 MHz".

- (b) Paragraph 2 - Delete and substitute:
 - 2. Applicability. - This test method is applicable to the measurement of radiated broadband emissions from all Class IV equipment.
- (c) Paragraph 3 - Delete "MIL-STD-461" and substitute "Tables I and II".
- (d) Paragraph 4.1 - Delete "see MIL-STD-461 for general test conditions" and substitute "see Section 4 of this standard for general test conditions".
- (e) Paragraph 4.2 - In the fifth line, delete "one meter" and substitute "two meters".

In the first and second lines of subparagraph (a), delete the words "tanks and other" without replacement.

In the third line of subparagraph (a), delete "one meter" and substitute "two meters".

In subparagraph (a)(3), delete and substitute:

(3) The conical or planar log spiral antenna shall be placed pointing down with its axis vertical over the opening.

- (f) Paragraph 6.1 - In the third line, delete "no" and substitute "do".
- (g) Paragraph 6.2 - In the second line, delete "unusal" and substitute "unusual".

In the fourth line, delete "acutal" and substitute "actual".

- 33. Method RE06 - Delete without replacement.
- 34. Method RS01 and RS02 - Delete without replacement.
- 35. Method RS03 - Delete and substitute the attached Method RS03.
- 36. Method (T) RS04 - Delete and substitute the attached Method RS04.

TABLE OF CONTENTS

	<u>Page</u>
Paragraph 1. SCOPE.	1
1.1 Scope	1
1.2 Format.	1
1.2.1 Numbering System.	1
1.2.3 Method of Reference	1
1.3 Units	1
2. REFERENCED DOCUMENTS	1
3. DEFINITIONS.	2
4. REQUIREMENTS	2
4.1 General Requirements.	C-3
4.2 Specific Requirements	2
4.2.1 Test Conditions	2
4.2.1.1 Ambient Electromagnetic Level	C-4
4.2.1.2 Ground Plane.	C-4
4.2.1.3 Accessory Equipment Precautions	2
4.2.1.4 Excess Personnel and Equipment.	2
4.2.1.5 Power Supply Characteristics.	2
4.2.1.6 RF Absorber Material.	C-4
4.2.1.7 Test Site	C-4
4.2.1.7.1 Shielded Enclosures	C-4
4.2.1.7.2 Open Areas.	C-5
4.2.2 Operation of Test Sample.	2
4.2.2.1 Control Adjustment.	2
4.2.2.2 Signal Inputs	2
4.2.2.3 Arrangement and Operating Conditions.	2
4.2.2.4 Bonding of Test Sample.	3
4.2.2.4.1 Shock and Vibration Isolators	3
4.2.2.4.2 External Ground Terminal.	3
4.2.3 Measuring Equipment	C-5
4.2.3.1 Test Antennas	C-5
4.2.3.1.1 Monopole Test Antenna Counterpoise.	C-5
4.2.3.2 Other Equipment Characteristics	C-5
4.2.3.2.1 Signal Sources.	C-12

TABLE OF CONTENTS (Continued)

	<u>Page</u>
4.2.3.2.2 Susceptibility Signals.	C-12
4.2.3.3 Use of Measuring Equipment	C-12
4.2.3.4 Equipment Warm-Up Time	C-15
4.2.3.5 Detector Function.	C-15
4.2.3.6 Grounding of Measurement Equipment	C-15
4.2.3.7 Monitoring of Measuring Equipment.	C-15
4.2.3.8 Identification of Spurious Responses in Measuring Equipment.	C-15
4.2.3.9 Calibration of Measuring Equipment	C-15
4.2.3.10 Accuracy of Measurements	C-16
4.2.4 Positioning of Measurement Antennas	C-16
4.2.5 Measuring Frequencies	5
4.2.6 Identification of Broadband and Narrowband Emissions	C-17
4.2.6.1 Pulsed CW Requirements.	C-18
4.2.7 Transient Measurements.	7
5. MEASUREMENT PROCEDURES	9

LIST OF FIGURES

	<u>Page</u>
Figure 1. Antenna Factor for Biconical Antenna.	C-8
2. Biconical Antenna With Bifalar Balun per ES-DL-176439 and ES-F-201286	C-9
3. Antenna Factor for Conical Log Spiral	C-10
4. Hooded Antenna Design Features and Characteristics.	C-11
RE02-1 Radiated Test Configuration (14 kHz to 30 MHz).	C-26
RE02-2 Radiated Test Configuration (30 MHz to 200 MHz)	C-27
RE02-3 Radiated Test Configuration (200 MHz to 10 GHz)	C-28
RE03-1 Typical Test Configuration - Spurious and Harmonic Emissions (1 to 12.4 GHz)	C-33
RE03-2 Typical Test Configuration - Spurious and Harmonic Emissions (12.4 to 40 GHz).	C-34
RE03-3 Typical Test Configuration - Spurious and Harmonic Emissions (Frequency Range as Applicable)	C-35
RS04-1 Parallel Strip Line for Radiated Susceptibility Tests	C-44
RS04-2 Parallel Strip Line for Radiated Susceptibility Tests (Top and Side Views).	C-45
RS04-3 Longwire Antenna Configuration in Shielded Enclosure	C-47
RS04-4 Configuration for Determining Concentric Line Termina- tions	C-48
RS04-5 Voltage Measurements for Determining Concentric Line Terminations.	C-48
RS04-6 Configuration for Matching Horizontal Line to Concen- tric Line	C-52
RS04-7 Attenuation Constant for Matching Horizontal Line and Concentric Line	C-52
RS04-8 Setup for Susceptibility Testing Using Parallel Plate Line.	C-54
RS04-9 Typical Line Calibration Chart.	C-55

LIST OF TABLES

	<u>Page</u>
TABLE I. MEASUREMENT ANTENNAS	C-6
II. SUGGESTED TEST EQUIPMENT	C-13
III. INDEX OF RADIATED MEASUREMENT PROCEDURES	C-24

TABLE III

INDEX OF RADIATED MEASUREMENT PROCEDURES

Method	Date	Title
RE02	March 1976	Radiated Emissions, 14 kHz to 10 GHz, Electric Field
REC3	March 1976	Spurious and Harmonic Emissions, 14 kHz to 40 GHz
RE05	March 1976	Radiated Emissions, Broadband, 150 kHz to 400 MHz
RS03	March 1976	Radiated Susceptibility, 30 MHz to 10 GHz, Electric Field
RS04	March 1976	Radiated Susceptibility, 14 kHz to 30 MHz, Electric Field

METHOD RE02

RADIATED EMISSION, 14 kHz TO 10 GHz, ELECTRIC FIELD

1. Purpose. - This method is used for measuring radiated electromagnetic emissions from electronic, electrical, and electromechanical equipment.
2. Applicability. - Any equipment or device to which this method is applicable shall be measured for radiated emission from all units, cables (including control, pulse, IF, video, antenna transmission lines, and power cables), and interconnecting wiring. This method applies to the transmitter fundamental, spurious radiation, oscillator radiation, and broadband emissions, but is not intended to be used for radiation emanating from antennas.
 - 2.1 Applicable Frequency Range for Test. -
 - a. Narrowband Emissions - 14 kHz to 10 GHz.
 - b. Broadband Emissions - 14 kHz to 400 MHz.
3. Apparatus. - The test apparatus shall consist of the following:
 - a. Test Antennas (Refer to Table I).
 - b. EMI Meter (Refer to Table II).
 - c. Line Impedance Stabilization Network (Refer to Table II).
4. Test Configuration and Procedures. -
 - 4.1 Test Configurations. - The test configuration for each applicable frequency range shall be as follows. The test item antenna, if any, shall be connected to a shielded dummy load.
 - a. 14 kHz to 30 MHz - The basic test configuration shown in Figure RE02-1.
 - b. 30 to 200 MHz - The basic test configuration shown in Figure RE02-2.
 - c. 200 MHz to 10 GHz - The basic test configuration shown in Figure RE02-3.
 - 4.2 Test Procedures. - The test procedures shall be as follows:

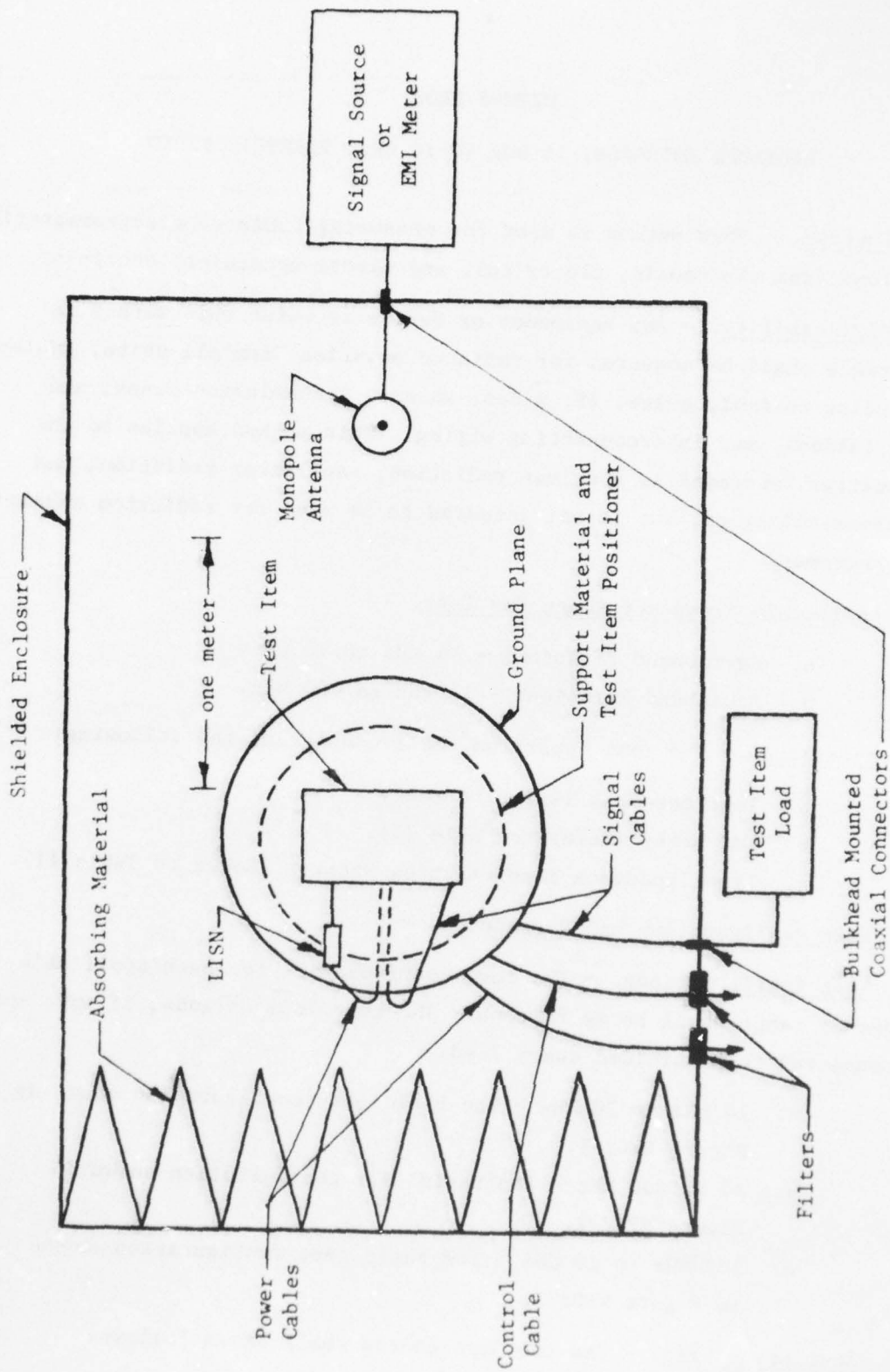

Figure RE02-1. Radiated Test Configuration (14 kHz to 30 MHz).

AD-A033 292

GEORGIA INST OF TECH ATLANTA ENGINEERING EXPERIMENT --ETC F/6 20/14
ELECTROMAGNETIC COMPATIBILITY RATIONALE REPORT: RADIATED TEST R--ETC(U)
APR 76 J C TOLER, J A WOODY

DOT-FA74WA-3372

UNCLASSIFIED

FAA/RD-76-70

NL

3 of 3
AD
A033292



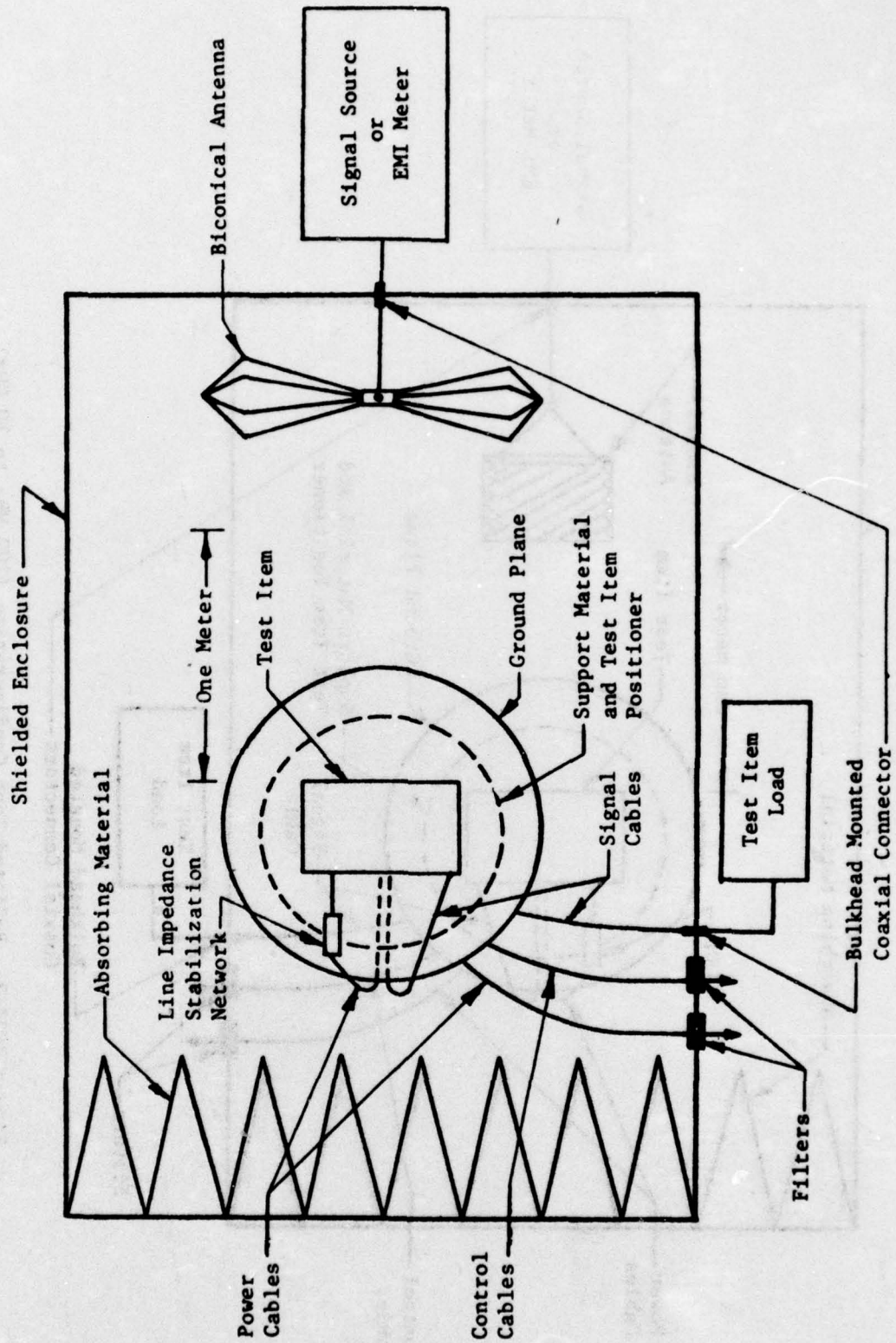

Figure RE02-2. Radiated Test Configuration (30 MHz to 200 MHz).

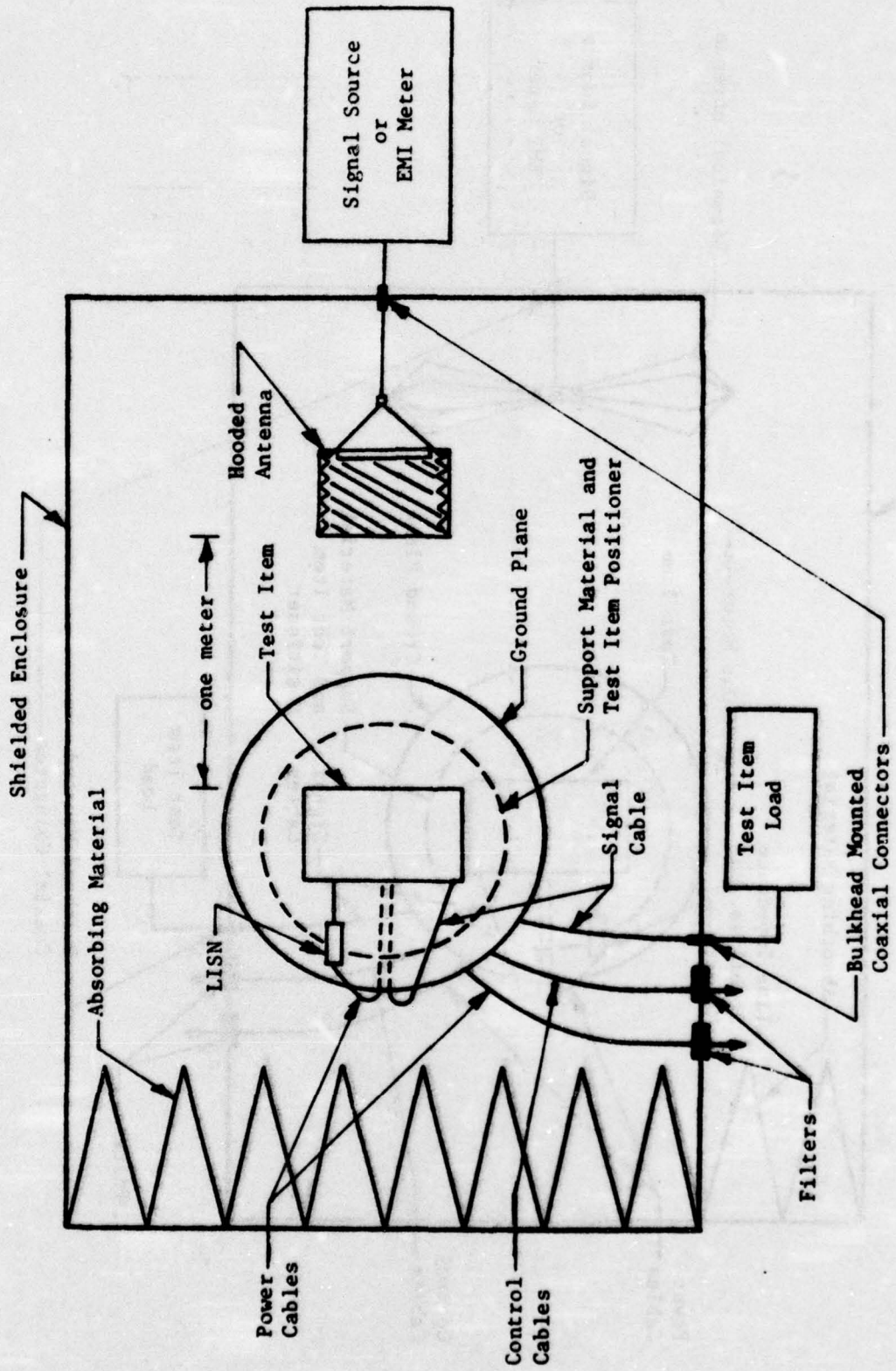

Figure RE02-3. Radiated Test Configuration (200 MHz to 10 GHz).

- a. Probe the test item as indicated in Paragraph 4 of this standard to locate the points of maximum radiation from the test item.
- b. Select and position the test antennas as indicated in Section 4 of this standard. In the frequency of 30 to 400 MHz, position the linearly polarized antenna so as to make both vertical and horizontal measurements.
- c. For each test antenna, scan the applicable frequency range of the test with the EMI meter and record the emission level and operational mode of the test item.

METHOD RE03

SPURIOUS AND HARMONIC EMISSIONS, 14 kHz TO 40 GHz

1. Purpose. - This method is used for measuring transmitter spurious and harmonic emissions in the radiated field.
2. Applicability. - This method is applicable to Class I transmitters when any one of the following conditions exist:
 - a. The direct coupled techniques of Method CE06 of MIL-STD-462, FAA Notice 1C cannot be applied, and/or
 - b. The transmitter power output is greater than 5 kilowatt average, and/or
 - c. The fundamental frequency is above 1.0 GHz, and/or
 - d. The test item's antenna is an integral part of the transmitter and cannot be replaced by a suitable dummy load.
3. Frequency Range of Test. - Frequency ranges of the test shall be as follows:

<u>Equipment Operating Frequency</u>	<u>Frequency Range of Test</u>
14 to 30 kHz	0.01 to 10 MHz
30 to 300 kHz	0.01 to 100 MHz
0.3 to 3 MHz	0.01 to 600 MHz
3 to 30 MHz	0.01 to 1,000 MHz
30 to 300 MHz	0.01 to 3,000 MHz
300 to 1,240 MHz	0.01 to 12,400 MHz
1,240 MHz and above	The lowest frequency of test shall be: <ol style="list-style-type: none"> a. Coaxial transmission lines: 200 MHz b. Waveguide transmission lines: $0.8 f_{co}$ The upper frequency limit shall be as follows:

Equipment Operating Frequency	Upper Frequency Limit
1.24 to 5.0 GHz	10 GHz or f_0 whichever is greater
5.0 to 12.4 GHz	5 f_0 or 40 GHz whichever is greater

4. Apparatus. -

4.1 Instrumentation required for testing in the frequency range of 14 kHz to 1,000 MHz is as follows: (Refer to Table II)

- a. EMI Meter.
- b. Attenuators or amplifiers as may be required to insure suitable signal levels at EMI meter input terminals.
- c. Antennas (Refer to Table I).

4.2 Instrumentation required for testing in the frequency range above 1000 MHz is as follows: (Refer to Table II)

- a. Spectrum analyzer.
- b. Traveling wave tube amplifier.
- c. Preselectors - yig filters.
- d. Frequency counter.
- e. Signal generators.
- f. Antennas (Refer to Table I).

5. Symbols. - Symbols are defined as follows:

- a. P_r = Power delivered to spectrum analyzer's input terminals.
- b. P_t = Power delivered to the transmitter's antenna at the transmitter's fundamental frequency.
- c. G_t = Gain of the transmitting antenna over an isotropic radiator. This value is expressed in dB.
- d. λ = Wavelength of the transmitted signal in meters.
- e. D = Maximum dimension of the receiving antenna in meters.

- f. d = Maximum dimension of the transmitting antenna in meters.
- g. G_r = The gain of the receiving antenna over an isotropic radiator + gain of the TWT - cable losses - attenuation or insertion loss of yig filters, and other adjustments as required by the test configuration.
- h. R = Separation between antennas in meters.
- i. P_{sp} = Power of spurious emission signal delivered to transmitting antenna.
- j. T = Pulse width in seconds.
- k. F_s = Desired frequency.
- l. N = Harmonic number shown on spectrum analyzer.
- m. F_{lo} = Local oscillator frequency of spectrum analyzer.
- n. F_{if} = Intermediate frequency of the spectrum analyzer.
- o. E_1 = Measured field strength in volts/meter.

6. Test Configuration and Procedures (General). - Two separate test procedures are given in the following paragraphs. The procedure of Paragraph 6.1 applies to the testing of equipment with operating frequencies above 1.0 GHz or at frequencies where adequate antenna gain information is available or can be determined. The procedures of Paragraph 6.2 apply to the testing of equipments at lower operating frequencies and in situations where the procedures of Paragraph 6.1 are not feasible.

6.1 Test Configuration and Procedure. - (1.0 GHz and above)

6.1.1 The test configuration shall be indicated in Figure RE03-1, RE03-2, or RE03-3, whichever is applicable, using the following procedure to establish the distances and actual equipments to be used.

- a. Equipment selection. Select the receiving antenna, TWT's or attenuators which will yield sufficient measurement system sensitivity to allow detection of the transmitter spurious emissions. The following equations should be solved and equipment so selected to assure a P_r approximately 0 dBm when P_t is the value derived from the transmitter's design data.

RADIATED EMISSIONS

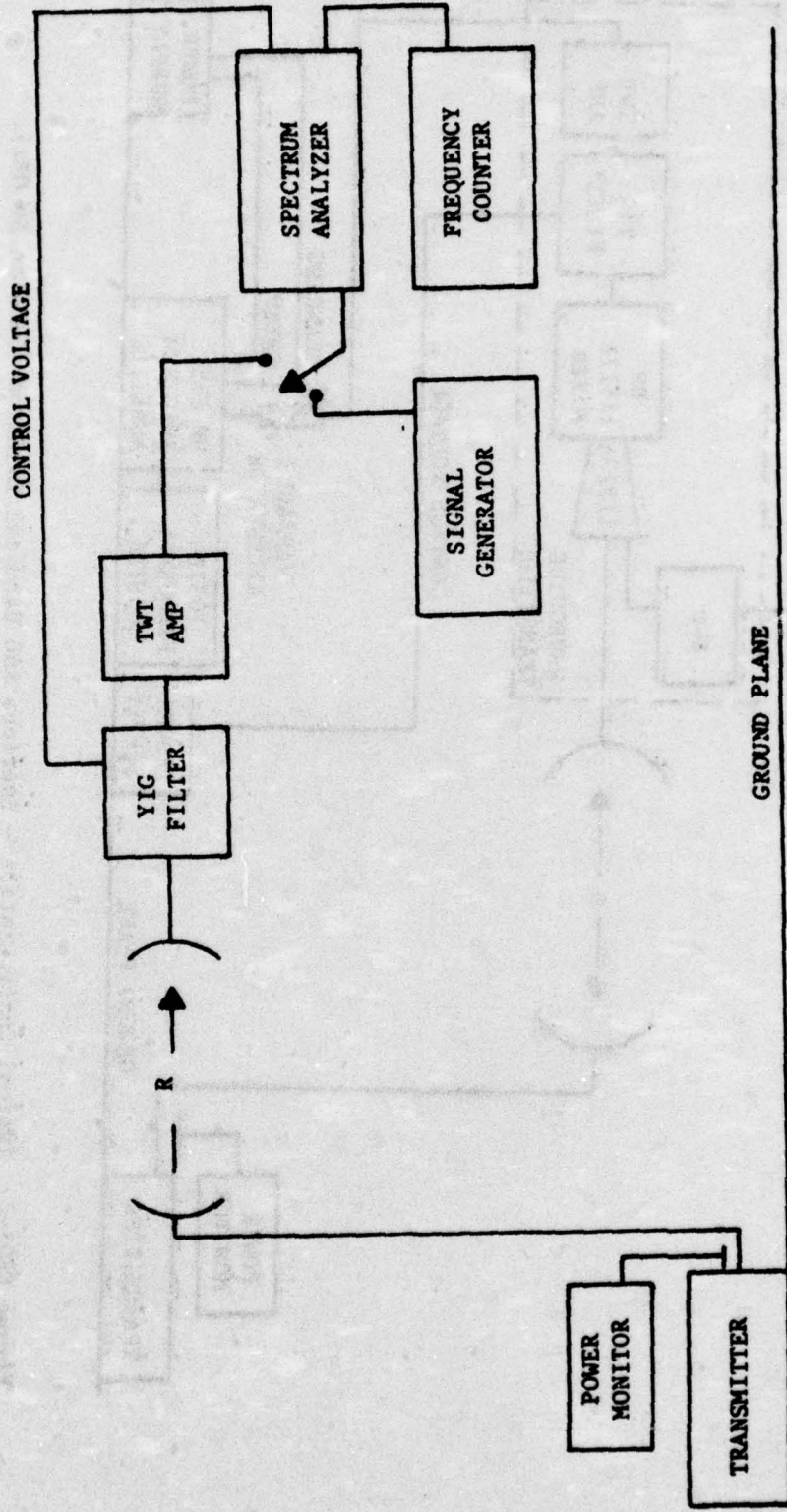

Figure RE03-1. Typical Test Configuration - Spurious and Harmonic Emissions (1 to 12.4 GHz).

RADIATED EMISSIONS

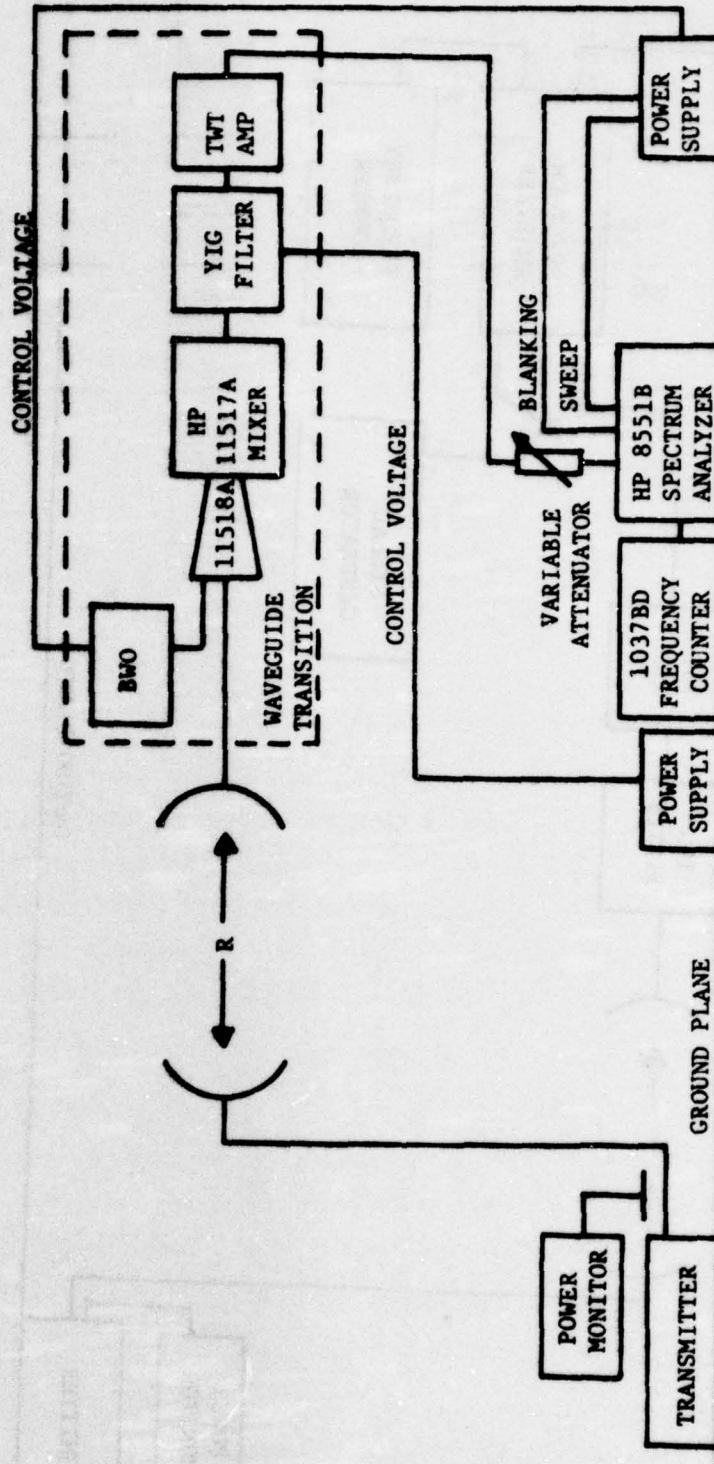

Figure RE03-2. Typical Configuration - Spurious and Harmonic Emission (12.4 to 50 GHz).

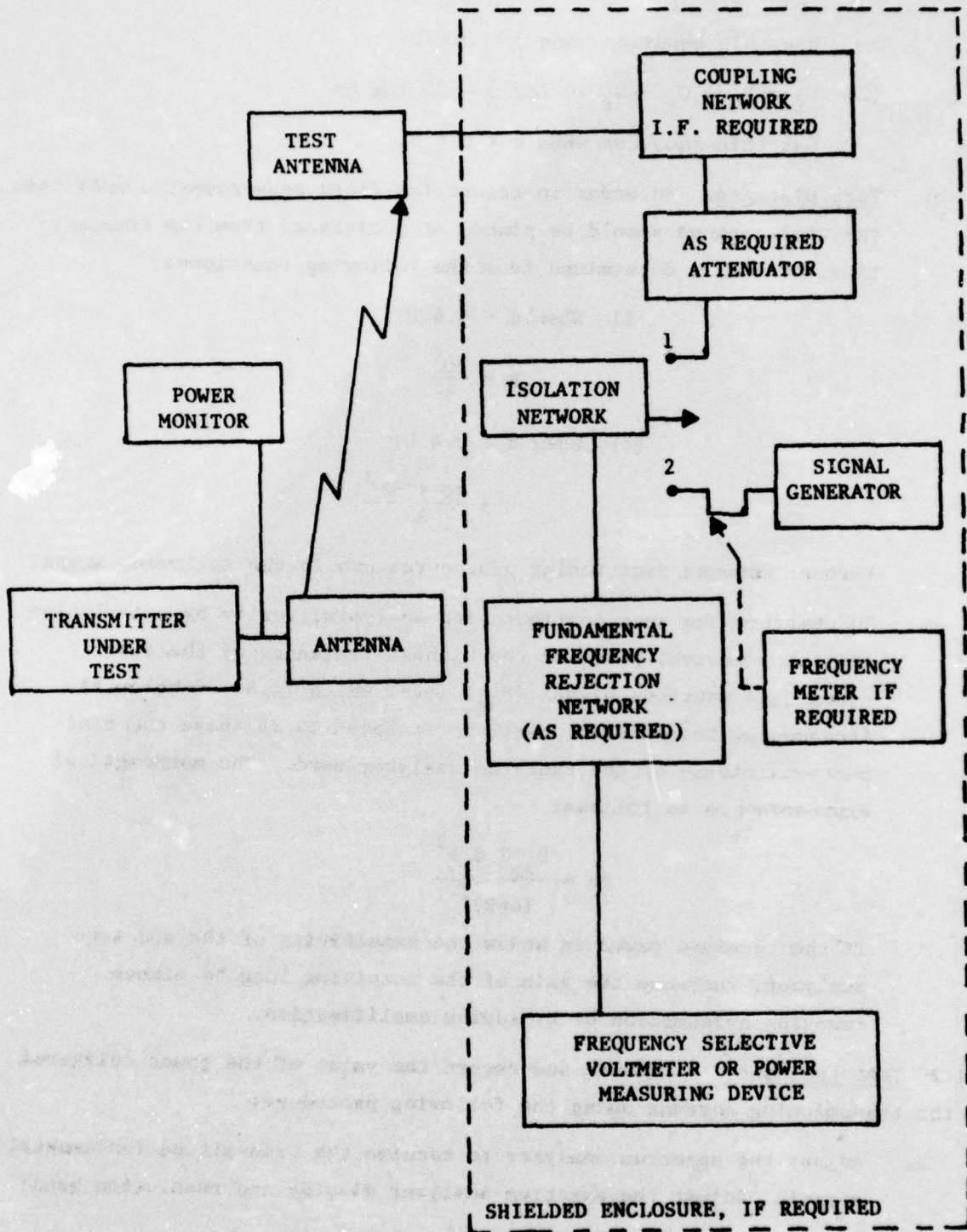

Figure RE03-3. Typical Configuration - Spurious and Harmonic Emission (Frequency Range as Applicable).

$$(1) P_r = P_t + G_t + G_r 40 \log \frac{\lambda}{D + d} - 20 \log 4\pi$$

Use this equation when $d \geq 0.4 D$.

$$(2) P_r = P_t + G_t + G_r 40 \log \frac{\lambda}{D} - 20 \log 8\pi$$

Use this equation when $d < 0.4 D$.

- b. **Test Distance.** In order to assure far-field measurement conditions, the test antenna should be placed at a distance from the transmitting antenna as determined from the following equations:

- (1) When $d < 0.4 D$

$$R = \frac{2D^2}{\lambda}$$

- (2) When $d \geq 0.4 D$

$$R = \frac{(D + d)^2}{\lambda}$$

Further antenna positioning procedures are in the following steps.

- c. To complete the test configuration analysis, verify by calculation that the received power at the highest frequency of the test, assuming a spurious signal (P_{sp}) level which is 80 dB below the fundamental transmitted power, is at least 10 dB above the minimum sensitivity of the spectrum analyzer used. The mathematical expression is as follows:

$$P_r = \frac{P_{sp} G_t G_r \lambda^2}{(4\pi R)^2}$$

If the received power is below the sensitivity of the spectrum analyzer, increase the gain of the receiving loop by either removing attenuation or by adding amplification.

- 6.1.2 **Test Procedure.** - Measure and record the value of the power delivered to the transmitting antenna using the following procedure:

- a. Adjust the spectrum analyzer to receive the transmitted fundamental signal. Adjust the spectrum analyzer display and resolution band-

width so that the incoming signal is properly displayed. For pulsed transmitters, the display bandwidths should be at least $10/T$, and the resolution bandwidth should be $1/10T$.

- b. For orientation of the transmitting and test antennas the following sequence shall be used:
 - (1) Where azimuth and elevation of the system antenna can be varied, this shall be done to produce the maximum signal at the test antenna. The azimuth angle and elevation angle between the antenna boresight axis of the system and test antenna shall be recorded after the signal is maximized.
 - (2) The test antenna shall be adjusted in elevation at each measurement frequency to obtain a maximum of received energy. The adjustment should be made over a distance calculated to include two nulls in the elevation interference pattern resulting from ground reflections, where they exist.
 - (3) All position information shall be recorded together with the test results.
- c. Further adjust the spectrum analyzer controls to obtain maximum resolution of the transmitted signal on the CRT display. Once this is accomplished, do not readjust the controls until the measurement is completed.
- d. Disconnect the spectrum analyzer from the measurement antenna and connect it to a substitution generator.
- e. Adjust the output of the substitution generator to produce the same spectral envelope on the spectrum analyzer as was indicated with the transmitted signal. The signal generator shall be modulated in a manner similar to the modulation used in the transmitter.
- f. Measure and record the power at f_0 delivered to the spectrum analyzer input from the calibrated signal generator.
- g. Verify the measurement technique and calibration at f_0 by substituting into the following equation:

$$P_t = \frac{(4\pi R)^2 R_r}{G_t G_r \lambda^2}$$

The above value of P_t should be within ± 2 dB of the value measured by the power monitor connected to the transmitter output. If a greater error exists, check the test configuration for errors in distance measurement, substitution, drift, correction factors, ground reflections, improper alignment and so forth.

- h. Repeat steps a. and f. for the remaining frequency range of test.

6.2 Test Configuration and Procedures - (below 1 GHz)

6.2.1 These test configurations and procedures are for equipments with operating frequencies below 1.0 GHz where the procedure of Paragraph 6.1 cannot be employed. The data obtained using this procedure will be in terms of field intensity at a given distance from the transmitting antenna. The field intensity measured at harmonic and spurious frequencies is compared to the value at the fundamental frequency. The limit is in dB relative to the level measured at the fundamental frequency and is derived from the Test Method RE03 limit of Figure 7, MIL-STD-461A, FAA Notice 1R, by comparing the absolute power limit placed on harmonics and spurious emissions to the known power rating of the transmitting source. The test configuration shall be as indicated in Figure RE03-3. The separation between the transmitting antenna and test antenna shall be at a distance of D^2/λ or 3λ , whichever is larger, unless otherwise specified. (D is the maximum dimension of the largest antenna.) Where the received signal at the fundamental frequency is less than the applicable limit above the sensitivity of the EMI meter, place a preamplifier capable of increasing the measurement sensitivity between the test antenna and the receiver. In Figure RE03-3 this should be placed between the switch and the EMI meter.

6.2.2 Test Procedure.

- a. Tune the transmitter to a standard test frequency with the fundamental rejection network bypass and the switch set to position one (1). Tune the frequency selective voltmeter to the same fre-

quency. Position the antennas to produce maximum received signal at each frequency (fundamental, spurious, harmonic), using the technique outlined in Paragraph 6.1 above. Set the switch to position 2 and determine the received signal level. This level must be at least as great as the applicable limit above the meter sensitivity. Record all settings.

- b. Insert the fundamental frequency rejection network, and tune it to reject the transmitter fundamental frequency. With minimum system attenuation and maximum instrument sensitivity, tune the frequency selective voltmeter continuously through the required frequency range to detect all emissions. Each time a spurious transmitter output is detected, adjust the meter to give a convenient reading. Determine the signal level and record all values. When determining the level of the responses, the attenuation of the signal sampling network at the spurious frequency shall be known.
- c. Repeat the foregoing steps at each transmitter test frequency.
- d. Apply effective height and other correction factors (cables losses, attenuation, etc.) as required to determine field intensity levels at the antenna.

7. NOTES

- a. When performing these tests, it may be necessary to enclose the measurement equipment in a shielded enclosure. This necessity arises from the fact that the spectrum analyzer may be susceptible to radiated fields. It is recommended that the spectrum analyzer be disconnected from the measurement antenna and the display checked to verify that a "back door" response is not being measured.
- b. When using the TWT's and yig filters, these parts should be located as near the antenna as possible. This is done so that maximum signal may be applied to the TWT input.
- c. It is necessary to monitor continually the transmitter's output power during test. If the power at f_0 changes by more than ± 2 dB, the test shall be terminated until such time that the original

output is obtained. Duty cycle considerations shall be adhered to and should be established as defined in the equipment's test plan.

- d. To measure the frequency of the incoming signal, note the signal identifier and harmonic number of the spectrum analyzer, since the frequency of the desired signal is derived from

$$F_s = N F_{10} + F_{if} .$$

METHOD RS03

RADIATED SUSCEPTIBILITY, 30 MHz TO 10 GHz, ELECTRIC FIELD

1. Purpose. - The purpose of this test is to ensure that a test item does not exhibit any degradation of performance, malfunction, or undesirable effects when immersed in an electric field in the frequency range of 30 MHz to 10 GHz.
2. Applicability. - This test method is applicable to all Class I equipments.
3. Apparatus. - The test apparatus shall consist of the following:
 - a. Signal Source (Refer to Table II).
 - b. EMI Meter (Refer to Table II).
 - c. Output Monitor - to monitor performance of the test sample.
4. Test Configurations and Procedures. -
 - 4.1 Test Configurations. - The test configuration for each applicable frequency range shall be as follows:
 - a. 30 to 200 MHz - The basic test configuration as shown in Figure RE02-2.
 - b. 200 MHz to 10 GHz - The basic test configuration as shown in Figure RE02-3.
 - 4.2 Test Procedures. - The test procedures shall be as follows:
 - a. Test signals shall be selected in accordance with Paragraph 4 of this standard.
 - b. Fields shall be generated, as required, with the antennas specified in Table I. Care shall be taken so that the test equipment is not affected by the test signals.
 - c. The specified field strength shall be established prior to the actual testing by placing a field measuring antenna at the same distance and in the same relative location as where the test item will be placed and adjusting the signal level applied to the transmitting antenna until the required field intensity is indicated. The voltage or power at the input terminals of the

transmitting antenna, required to establish the specified field shall be monitored and recorded. When performing this calibration in a shielded enclosure, the measurement antenna shall be placed in the exact location that the test item will occupy. (This calibration may be used for all subsequent testing provided that the data was taken in a reflective-free area or the exact same shielded enclosure test item location is used.)

- d. Determine those frequencies at which the test item is susceptible. At these frequencies, determine the threshold of susceptibility. Record all pertinent data.

METHOD RS04

RADIATED SUSCEPTIBILITY, 14 kHz TO 30 MHz, ELECTRIC FIELD

1. Purpose. - The purpose of this test is to ensure that the test item does not exhibit any degradation of performance, malfunction, or undesirable effects when immersed in an electric field in the frequency range of 14 kHz to 30 MHz.
2. Applicability. - This test method is applicable to all Class I equipments.
3. Apparatus. -
 - 3.1 Longwire Method. - The test apparatus shall consist of the following:
 - a. 2 vacuum tube voltmeters (VTVM).
 - b. RF signal generator capable of 1 volt output into a 100 ohm load.
 - c. A dc resistance bridge.
 - d. Assortment of resistors from 100 to 1000 ohms ("non-inductive") of adequate power dissipating capability.
 - e. Wire - #12 copper.
 - 3.2 Parallel Plate Line Method. - The test apparatus shall consist of the following:
 - a. Parallel plate line (see Figures RS04-1 and RS04-2).
 - b. Signal source capable of delivering the required signals.
 - c. EMI meter or VTVM.
 - d. Matching networks.
 - e. 30 MHz low pass filter (optional).
4. Test Procedure. - Two separate test procedures are given in the following paragraphs. The Longwire procedure of Paragraph 4.1 applies to the testing of equipments which are not size compatible with the dimensions of the parallel plate line in the procedure of Paragraph 4.2. If the test item is size compatible, either procedure will provide satisfactory results and may be used for this test method. The Longwire procedure is preferred only because it requires less extensive construction and will accept larger test items.

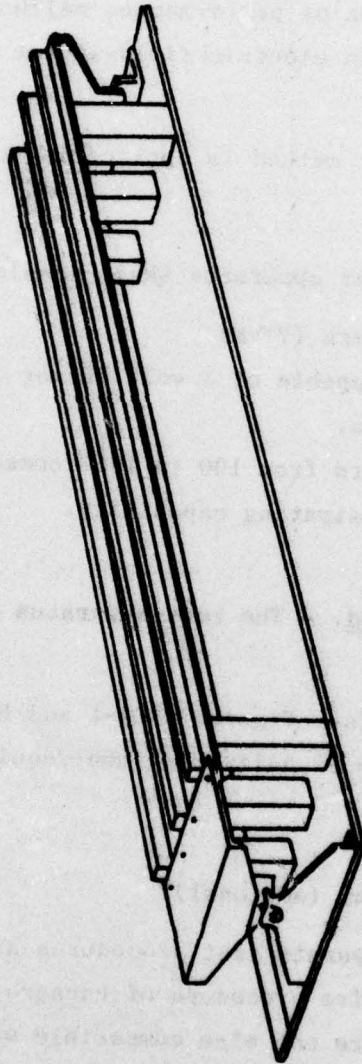

Figure RS04-1. Parallel Strip Line for Radiated Susceptibility Tests.

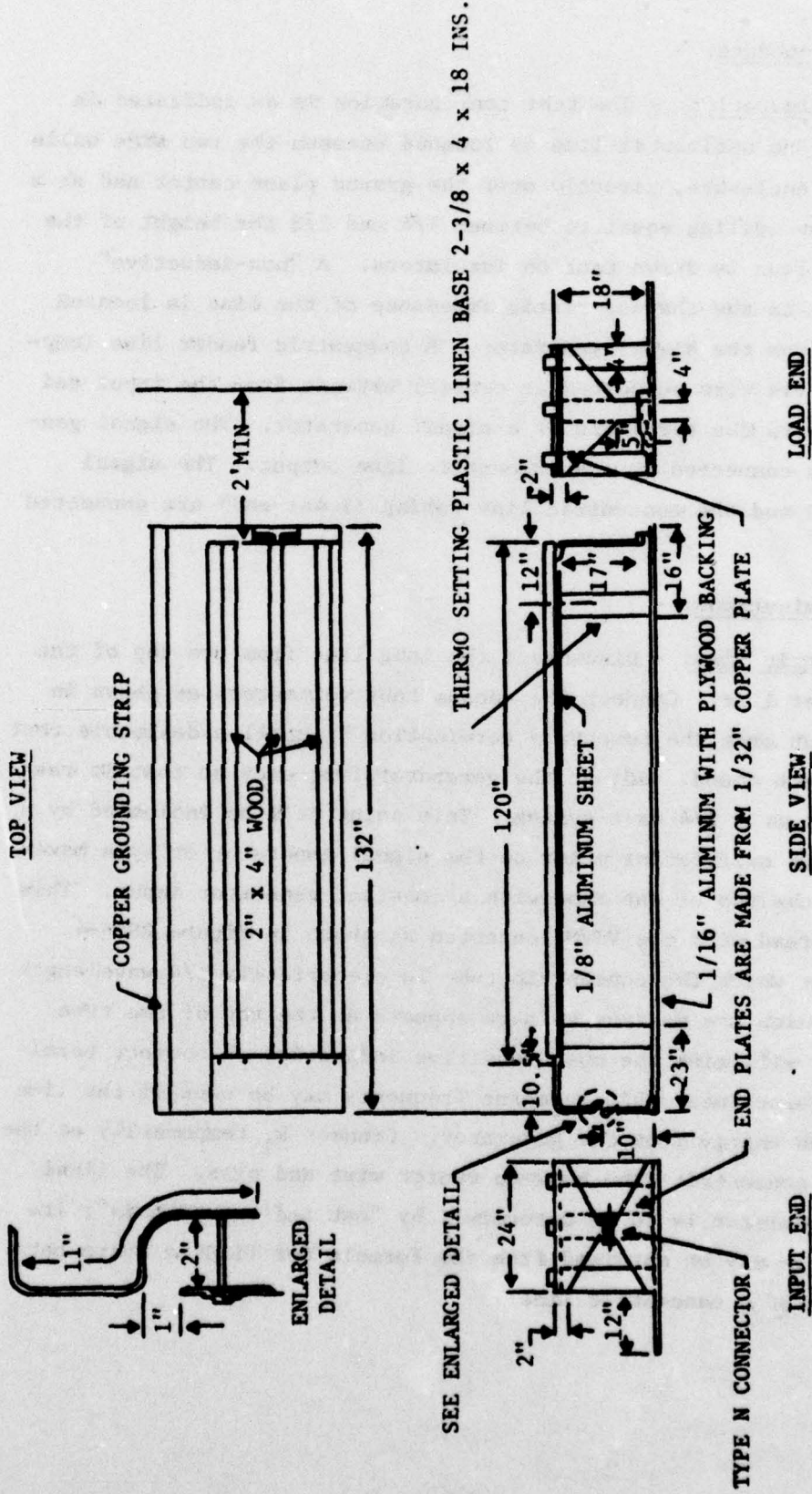

Figure RS04-2. Parallel Strip Line for Radiated Susceptibility Tests (Top and Side View).

4.1 Longwire Procedure. -

4.1.1 Test Configuration. - The test configuration is as indicated in Figure RS04-3. The horizontal line is located between the two side walls of the shielded enclosure, directly over the ground plane center and at a distance from the ceiling equal to between $1/4$ and $1/3$ the height of the enclosure. The line is drawn taut on insulators. A "non-inductive" resistance equal to the characteristic impedance of the line is located at the far end from the signal generator. A concentric feeder line (copper tubing with #16 wire supported in center) extends from the input end of the line down to the terminals of a signal generator. The signal generator output is connected to the concentric line output. The signal generator ground and the concentric line tubing (lower end) are connected to the shield.

4.1.2 Line Terminations. -

4.1.2.1 Concentric Line. - Disconnect the long line from the top of the concentric feeder line. Connect the vacuum tube voltmeters as shown in Figure RS04-4 but omit the temporary termination R_1 until a desirable test frequency has been found. Adjust the generator frequency so that it resonates the line as a $1/4$ wave system. This point will be indicated by a dip in the output calibrating meter on the signal generator or by a maximum voltage at the top of the tube with a constant generator input. This voltage may be read with the VTVM connected as shown in Figure RS04-4. The frequency at which the concentric tube is electrically $1/4$ wavelength is the one at which the maximum voltage appears at the top of the tube and, therefore, will give the most sensitive indication of correct termination. A frequency near this resonant frequency may be used if the line absorbs too much energy from the generator. Connect R_1 temporarily at the top end of the concentric line between center wire and pipe. The final value of this resistor is to be determined by "cut and try methods"; its approximate value may be obtained from the formula for finding characteristic impedance of a concentric line:

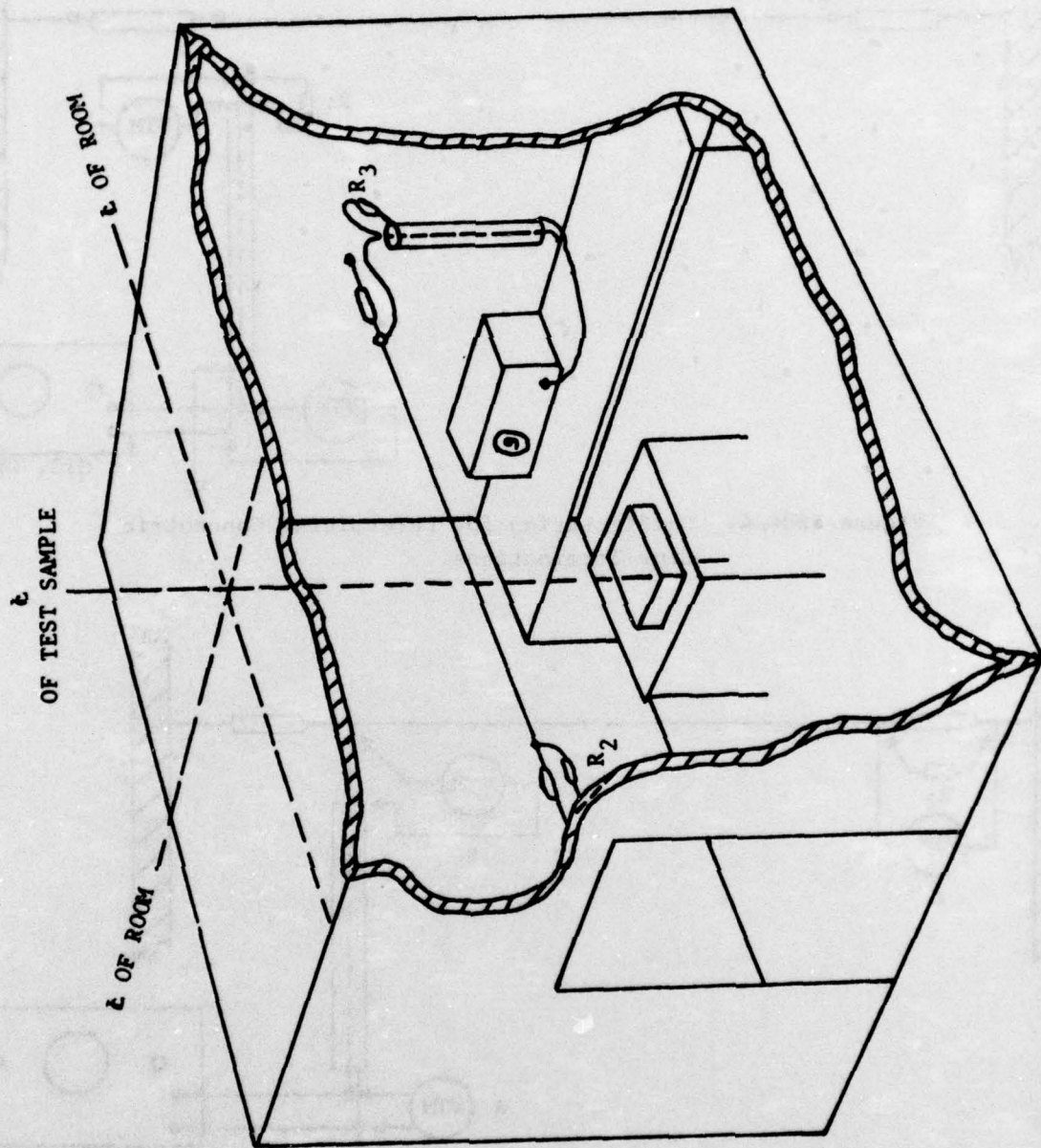

Figure RS04-3. Longwire Antenna Configuration in Shielded Enclosure.

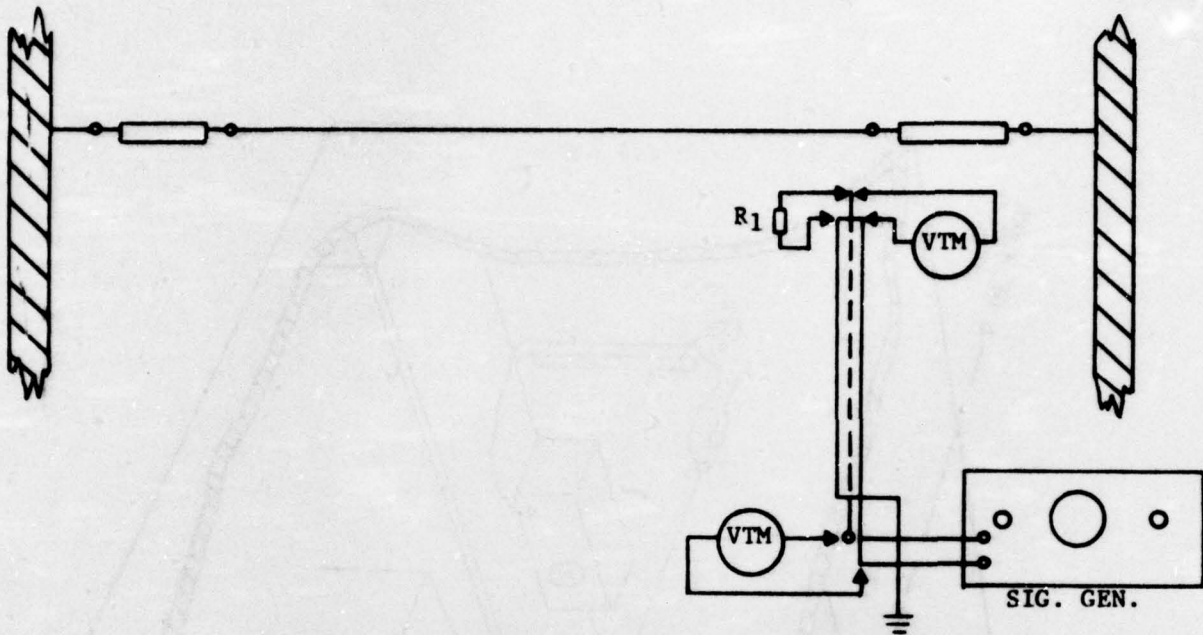

Figure RS04-4. Configuration for Determining Concentric Line Terminations.

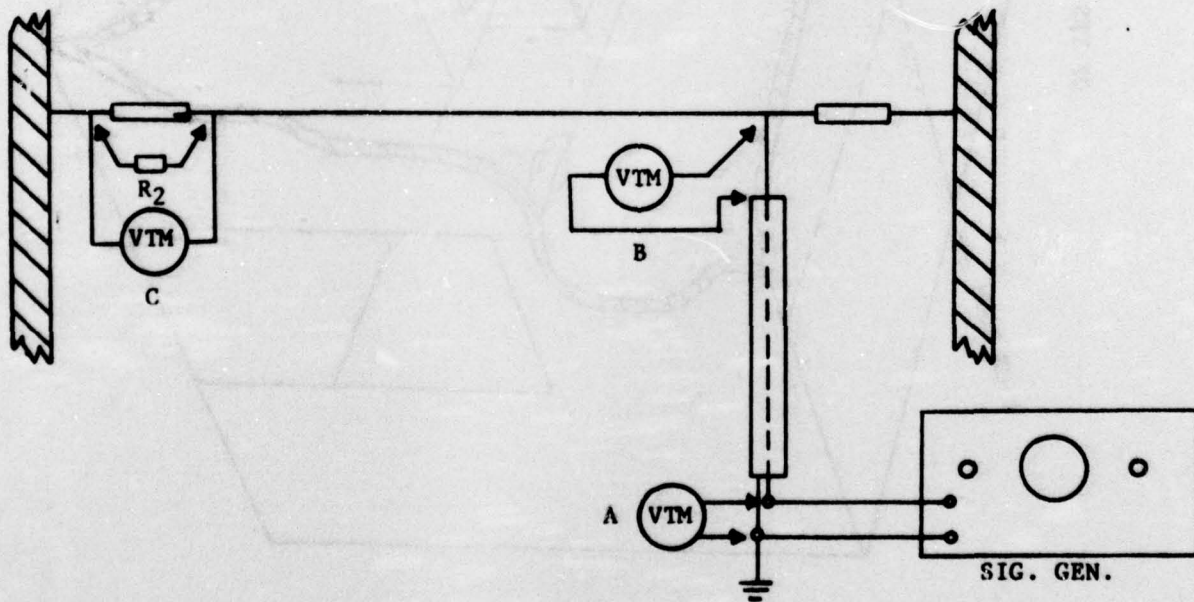

Figure RS04-5. Voltage Measurements for Determining Concentric Line Terminations.

$$Z_0 = R_1 = 138 \log_{10} \frac{d_2}{d_1}$$

where

d_2 = inside diameter of tube and
 d_1 = outside diameter of center conductor.

For a specific case of a 1 inch tube and a #14 wire, the value is approximately 150 ohms. Across the resistor R_1 , connect a VTVM. At the input end of the tube near the generator, connect the other VTVM (see Figure RS03-4). With the generator set at zero output, adjust the voltmeters for zero reading. With an input to concentric tube of one or two volts, the meters will read the same if the selected R_1 is the correct termination for the system. If the voltage at the top end of the tube is higher than the voltage at the lower end, the termination is too high a value (and visa versa). By successive trials, a value of resistance can be found which will terminate the line properly. Several resistors in parallel or series combinations may be used to get the required value if a single resistor of correct value cannot be found. Successive lower frequencies should then be tried and should result in identical readings on the two meters if everything is in order. This termination can now be disconnected and measured on a dc resistance bridge, the value being recorded as R_1 .

4.1.2.2 Termination of Horizontal Line. - With the termination of the concentric line removed, connect the end of the horizontal line to the center wire of the tube (see Figure RS04-5). With the voltmeters in positions A and C and temporary termination R_2 (approximated with following equations) removed, the frequency at which the system is $1/4$ wavelength is found as in section 4.1.2.1. This frequency is to be used in the following accurate determination of R_2 .

The following equations can be employed to determine an approximate value for R_2 :

Case 1 - Wire is much closer to ceiling than to floor:

$$Z_0 = 138 \log_{10} \frac{4D}{d}$$

where D = distance from wire to ceiling and

d = diameter of wire (80.81×10^{-3} inches for #12 wire).

Case 2 - Distance of wire to ceiling is greater than 1/3 enclosure height

$$Z_0 = \left[138 \log \frac{h}{d} \right] + 5$$

where h = height of shielded enclosure and

d = diameter of wire.

For finding the exact value of R_2 , the voltmeters are connected in positions B and C (see Figure RS04-5); proceed as in paragraph 4.1.2.1 to find the correct termination. Once the voltmeters read the same or within 0.1 volt of one another for several frequencies, the termination may be removed, measured on a bridge and replaced permanently as part of the system. Record termination value as $R_2 = Z_L$, the characteristic impedance of the line, to be used later in calculation of final concentric line feeder termination and attenuation constant.

4.1.2.3 Matching the Horizontal Line to the Concentric Tube Feeder. - The termination found in Paragraph 4.1.2.2 is the correct value for the single wire horizontal line alone and will be the impedance one would "see" looking in the end opposite to that termination. However, this resistance is not the correct value for proper termination of the top of the concentric line. Since the termination of the concentric line at this point is of concern, a resistor may be put in as a termination, which, in parallel with the impedance presented by the horizontal line, will give the value of resistance determined in Paragraph 4.1.2.1 as the correct termination of the concentric line. The formula for finding this resistance is the usual one for finding values of parallel resistance combinations.

$$R_3 = \frac{R_1 \times R_2}{R_2 + R_1}$$

where R_1 = termination for concentric line from Paragraph 4.1.2.1,
 R_2 = termination for horizontal line from Paragraph 4.1.2.2, and
 R_3 = termination which must be put across the top end of concentric line as indicated in Figure RS04-6.

After both terminations have been placed in the system (see Figure RS04-6), a final check should be made to see if the voltages at the bottom end of concentric line and far end of the horizontal line remain substantially the same over a frequency range from 14 kHz to 30 MHz.

4.1.3 Determination of an attenuation constant (K) relating the voltage at point A of Figure RS04-7 to field strength in microvolts per meter ($\mu\text{V/m}$) around transmission line at a known distance.

$$E \mu\text{V/m} = 2.36 \times 10^3 \frac{E_L}{Z_L} \left(\frac{1}{d} + \frac{1}{2d_1 - d} - \frac{1}{2d_2 + d} \right)$$

and
$$\frac{1}{K_d} = \frac{2.36 \times 10^3}{Z_L} \left(\frac{1}{d} + \frac{1}{2d_1 - d} - \frac{1}{2d_2 + d} \right)$$

or
$$\frac{1}{K_d} = E \mu\text{V/m}$$

where $E \mu\text{V/m}$ = field strength at known distance (microvolts per meter),

E_L = μV into line at point A (Figure RS04-7) from a signal generator,

Z_L = characteristic impedance of line,

d, d_1, d_2 (inches) are distances as indicated in Figure RS04-7, and

K_d = attenuation constant (factor).

K_d is a constant and, for a standard test distance d , in a given enclosure can always be used to determine field strength in microvolts per meter in terms of the generator input in microvolts.

For example: If this constant ratio is found to be 5, then to obtain a field strength at the test item of 1 volt/meter, the signal generator input will be set at 5 volts. Calculations should be checked by actual measurement of the field.

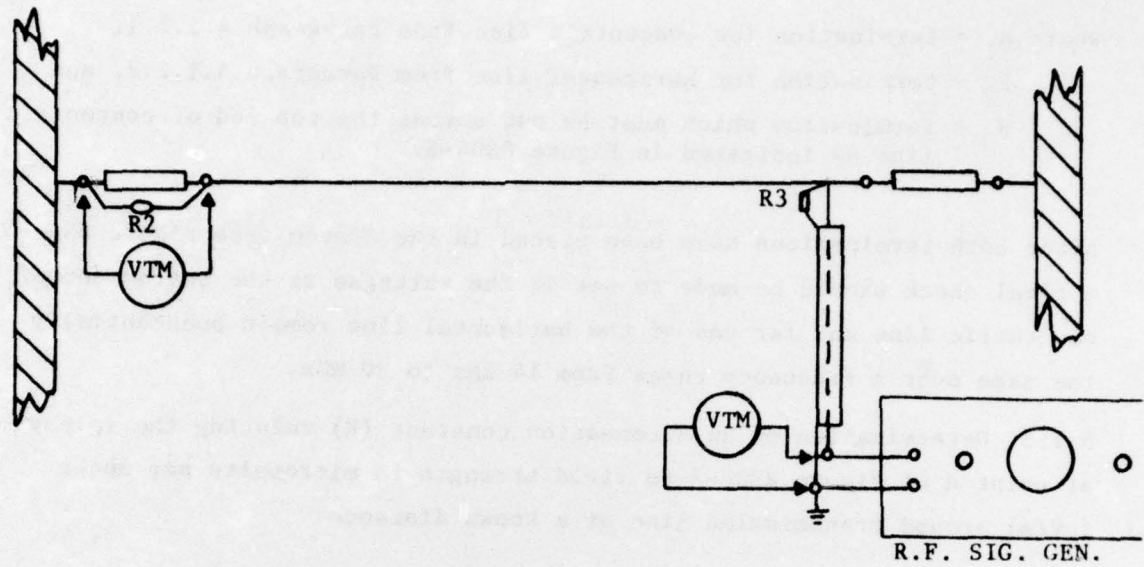

Figure RS04-6. Configuration for Matching Horizontal Line to Concentric Line.

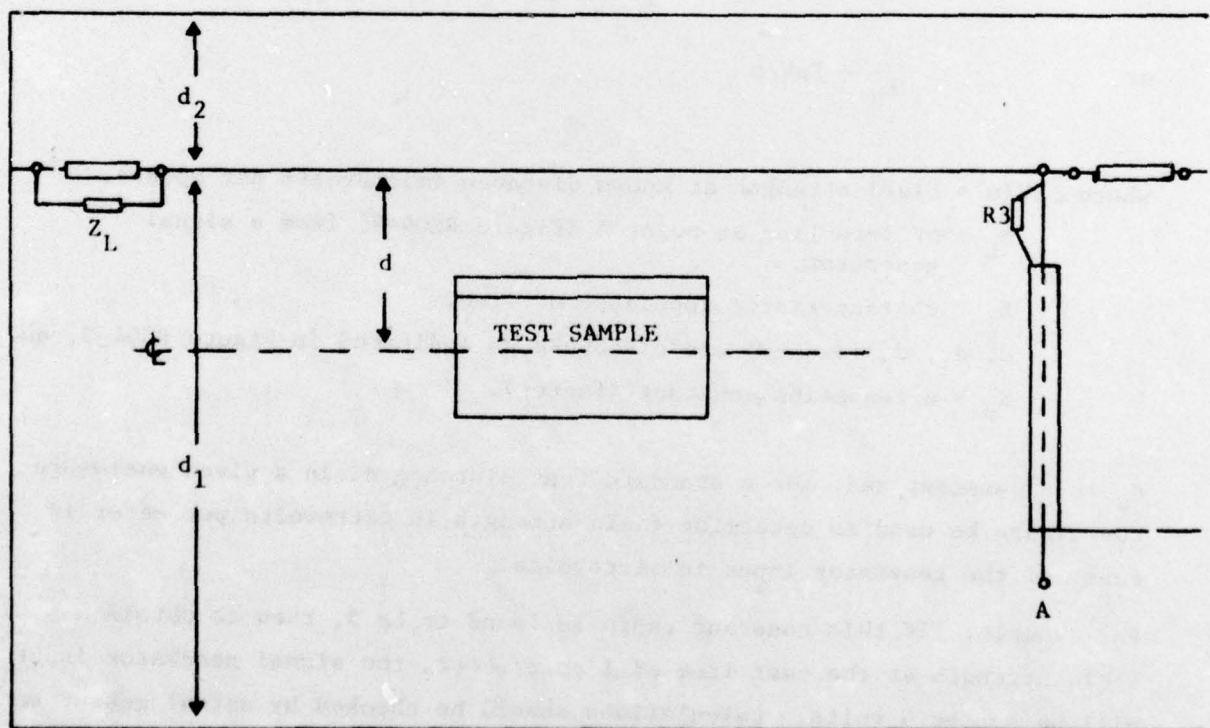

Figure RS04-7. Attenuation Constant for Matching Horizontal Line and Concentric Line.

4.2 Parallel Plate Line Procedure. -

4.2.1 Configure the equipment as shown in Figure RS04-8 with special emphasis on placing the test item as much to the center of the line as possible. Interconnecting and power leads shall be kept 4 to 6 centimeters above the ground plane and laid out parallel to the line for a length not less than 1 meter. Select test signals in accordance with applicable requirements of MIL-STD-461, FAA Notice 1R or as specified in the Test Plan.

4.2.2 By means of the calibration chart of electric field intensity as a function of the EMI meter reading (see Figure RS04-9), corrected by the matching pad insertion loss, adjust the output of the signal generator so that the fields between the plates correspond to the applicable limits.

4.2.3 The test item shall be tested to two orientations in its upright position, one where its front face is directed out toward the side of the line and another where its face is directed along the length of the line. Sides which have openings for power leads, shafts, ventilation, etc. shall be faced upward toward the top line plate. In no case shall the test item be closer than 10 centimeters to the upper plate.

4.2.4 The chassis of the test item shall be grounded through the power cord only. An insulating material shall be placed between the test item and the lower plate of the line.

4.2.5 Determine the frequencies and the minimum field strength at which the test item is susceptible. Record all pertinent data.

4.3 Notes. -

4.3.1 Especially important to obtaining a uniform field is the loading of the line with a non-inductive resistor. This applies equally to the matching network used with the EMI meter. All resistors should be chosen with ± 1 percent tolerance.

4.3.2 Care should be taken to assure that the resistive load used will be able to handle the power which is to be applied.

PAD INSERTION LOSS CALCULATION

Example:

$$V_0 = \frac{83}{52.2 + 83} V_{in}$$

$$10 \log \frac{P_{in}}{P_{out}} = 10 \log \frac{\left(\frac{V_{in}}{50}\right)^2}{\left(\frac{83 V_{in}}{135}\right)^2} = 10 \log \left(\frac{83}{135}\right)^2 \frac{(V_{in})^2}{(V_{in})^2} = 10 \log \left(\frac{83}{135}\right)^2$$

$$\begin{aligned} &= 20 \log \frac{83}{135} + 10 \log \frac{83}{50} \\ &= 20 \log 1.625 + 10 \log 1.66 \\ &= 20 \times .21 + 10 \times .22 \\ &= 4.20 + 2.2 = 6.4 \text{ dB} \end{aligned}$$

LOAD AND RESISTOR VALUES PRESENTED HERE ARE TYPICAL. THE PROPER VALUE WILL HAVE TO BE DETERMINED ON AN INDIVIDUAL BASIS. ATTEMPTS AT DETERMINING THE CHARACTERISTIC IMPEDANCE OF THE LINE BASED ON CLASSICAL PARALLEL STRIP TRANSMISSION LINE THEORY ARE NOT SUCCESSFUL BECAUSE OF THE INHERENT ASSUMPTION THAT THE WIDTH OF THE STRIPS IS MUCH GREATER THAN STRIP SEPARATION.

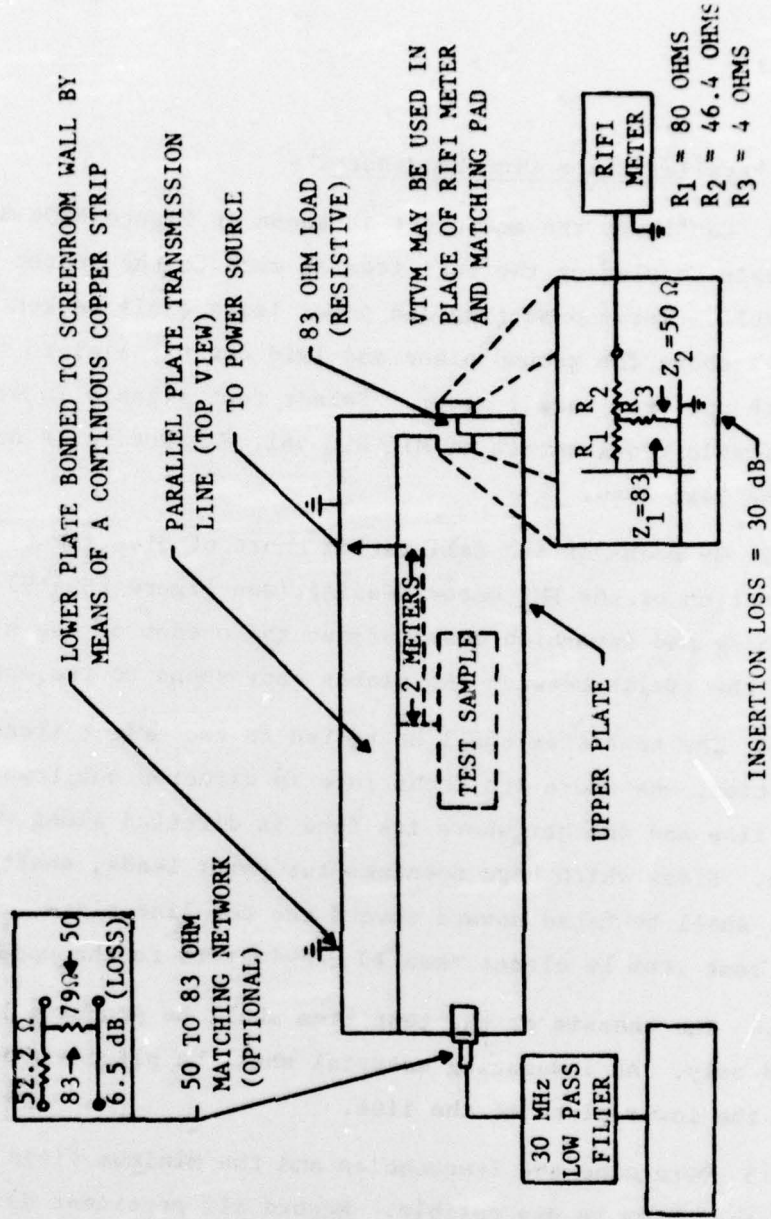

Figure RS04-S. Setup for Susceptibility Tests Using Parallel Plate Line.

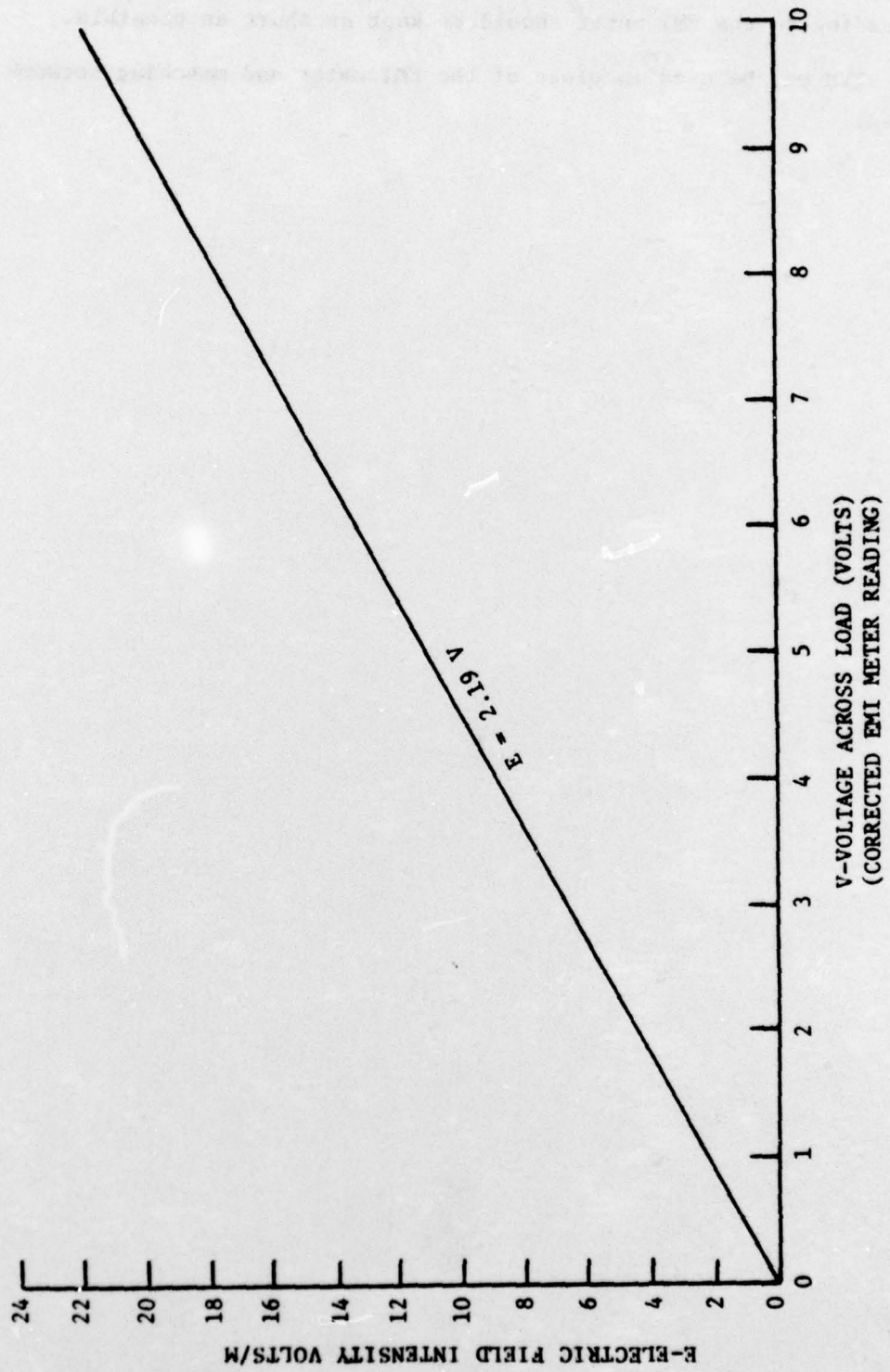

Figure RS04-9. Typical Line Calibration Chart.

4.3.3 The EMI meter should be placed outside the shielded enclosure. Cables leading to the EMI meter should be kept as short as possible.

4.3.4 A VTVM may be used in place of the EMI meter and matching network if desired.



