

AD-A033 294

NAVAL WEAPONS CENTER CHINA LAKE CALIF
TRANSMISSION OF TELEMETRY DATA BY EXISTING TELEVISION SYSTEMS.(U)
OCT 76 J L RIEGER
NWC-TP-5837

F/G 9/6

UNCLASSIFIED

NL

| OF |

AD
A033294



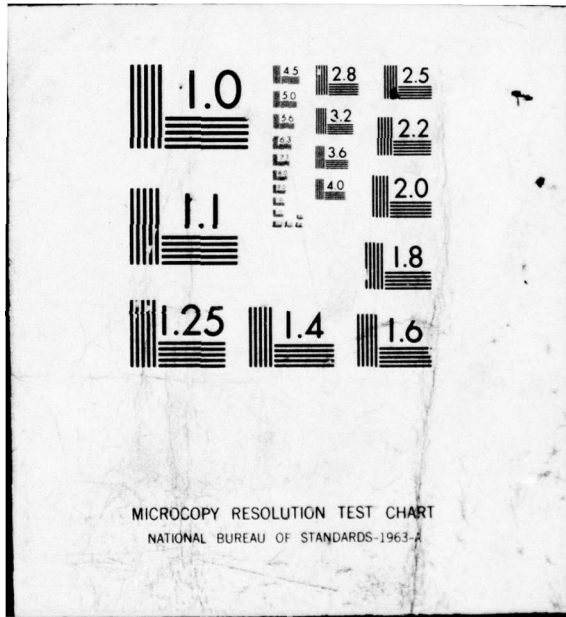

ADA033294

NWC TP 5837

12
B.S

Transmission of Telemetry Data by Existing Television Systems

by
James L. Rieger
Range Department

OCTOBER 1976

Approved for public release; distribution unlimited

DDC
RECEIVED
DEC 13 1976
A

Naval Weapons Center

CHINA LAKE, CALIFORNIA 93555



Naval Weapons Center

AN ACTIVITY OF THE NAVAL MATERIAL COMMAND

R. G. Freeman, III, RAdm., USN Commander

G. L. Hollingsworth Technical Director

FOREWORD

This project was authorized by AIRTASK ZF61-512-001 issued by the Director of Laboratory Programs, Naval Material Command. The work described was performed from September 1974 to July 1975. This report is a final report on theoretical and experimental studies conducted to determine the feasibility of adding data signals to an existing television link.

The report was reviewed for technical accuracy by Franklin Hartzler, William T. Lamb, and Robert Vorwerk.

Released by
W. R. HATTABAUGH, *Head*
Test and Evaluation Department
17 August 1976

Under authority of
G. L. HOLLINGSWORTH
Technical Director

NWC Technical Publication 5837

Published by Technical Information Department
Collation Cover, 16 leaves
First printing 195 unnumbered copies

SEARCHED	White Section	<input checked="" type="checkbox"/>
INDEXED	Ref Section	<input type="checkbox"/>
CLASSIFIED		<input type="checkbox"/>
ABSTRACTED		
BY	DISTRIBUTION/AVAILABILITY CODE	
Dist.	AVAIL. OR. OR. SPECIAL	
A		

UNCLASSIFIED

SECURITY CLASSIFICATION OF THIS PAGE (When Data Entered)

REPORT DOCUMENTATION PAGE		READ INSTRUCTIONS BEFORE COMPLETING FORM	
1. REPORT NUMBER NWC-TR-5837	2. GOVT ACCESSION NO.	3. RECIPIENT'S CATALOG NUMBER	4. RECIPIENT'S CATALOG NUMBER
6. TRANSMISSION OF TELEMETRY DATA BY EXISTING TELEVISION SYSTEMS		5. TYPE OF REPORT & PERIOD COVERED	
7. AUTHOR(s) James L. Rieger		6. PERFORMING ORG. REPORT NUMBER	
9. PERFORMING ORGANIZATION NAME AND ADDRESS Naval Weapons Center China Lake, CA 93555		8. CONTRACT OR GRANT NUMBER (if any)	
11. CONTROLLING OFFICE NAME AND ADDRESS Naval Weapons Center China Lake, CA 93555		10. PROGRAM ELEMENT, PROJECT, TASK AREA & WORK UNIT NUMBERS AIRTASK ZF61-512-001	
14. MONITORING AGENCY NAME & ADDRESS (if different from Controlling Office) 33 p.		12. REPORT DATE October 1976	
		13. NUMBER OF PAGES 30	
		15. SECURITY CLASS. (of this report) UNCLASSIFIED	
		15a. DECLASSIFICATION/DOWNGRADING SCHEDULE	
16. DISTRIBUTION STATEMENT (of this Report) Approved for public release; distribution unlimited.			
17. DISTRIBUTION STATEMENT (of the abstract entered in Block 20, if different from report) F61512 / ZF61512001			
18. SUPPLEMENTARY NOTES			
19. KEY WORDS (Continue on reverse side if necessary and identify by block number) Television Bandwidth (Bandwidth Compression) Video Spectrum Telemetry			
20. ABSTRACT (Continue on reverse side if necessary and identify by block number) See reverse side			

DD FORM 1 JAN 73 1473

EDITION OF 1 NOV 65 IS OBSOLETE
S/N 0102-014-6601

UNCLASSIFIED

SECURITY CLASSIFICATION OF THIS PAGE (When Data Entered)

403019

UB

~~UNCLASSIFIED~~

SECURITY CLASSIFICATION OF THIS PAGE(When Data Entered)

(U) *Transmission of Telemetry Data by Existing Television Systems*, by James L. Rieger. China Lake, Calif., Naval Weapons Center, October 1976. 30 pp. (NWC TP 5837, publication UNCLASSIFIED.)

(U) By encoding an existing TV system in which the signal contains predictable patterns or redundancy, each of which implies that less than an available bandwidth is being used, it is possible to transmit telemetry data and video simultaneously. A nearly orthogonal system could be inserted into blank portions of an existing black-and-white or color video presentation. Theoretically at least, the added data stream should not affect the existing picture, nor should the existing picture interfere with the added data stream.

(U) A demonstration model is described that was designed to measure the effects of adding piggyback data to an existing video system to evaluate results by comparison with known data signals and for subjective evaluation of the resulting picture.

(U) The report covers characteristics of black-and-white and color TV systems; determinations on what additional data could be transmitted without interference; and descriptions of a modulator-demodulator, a carrier generator, and other hardware designed to test the concept.

UNCLASSIFIED

SECURITY CLASSIFICATION OF THIS PAGE(When Data Entered)

CONTENTS

Introduction 3

Black-and-White TV Systems 3

 NTSC System Characteristics 4

 General Telecine System Characteristics 6

Color TV Systems 6

 Color Picture Projection 6

 Bandwidth Compression of Color Information 7

 Color Subcarrier Characteristics 8

 Color Pickup Systems 11

 Color Transmission/Recording Characteristics 11

Interference-Free Data Transmission 12

 TV Signal Redundancy 13

 Eye Sensitivity to Subcarrier Characteristics 14

 Subcarrier Modulation Effects 16

 Sync Generator for TV-Encoder System 18

Demonstration TV-Encoder Unit 18

Test Results 20

Additional Considerations 24

 Spectral 24

 Noise 25

 Ground Station Operations 26

 Data Format 26

 Cost 27

Conclusions 27

Appendix A: Phase-Lock Oscillators 28

ACKNOWLEDGMENT

The author gratefully acknowledges the help of the many individuals who contributed to the effort required to turn theoretical considerations into demonstrable hardware. Special thanks go to Allan M. Wetzstein and Jon Schmidt, who built the early prototypes, and to James Webb, who built the final form of some of the circuits; and especially to Edward K. Tipler, who interconnected the circuits and made them function, and who produced the demonstration videotape. The various branches of the Test and Evaluation Department provided some of the borrowed hardware and a great deal of encouragement.

INTRODUCTION

This report describes a data-in-video system that can be used to transmit telemetry data from a location already covered by a TV picture (color or black-and-white) in such a manner as to take advantage of certain characteristics of the TV medium as well as characteristics of the eye for which the video display is intended. With such an encoding system, a saving can be made in transmission and recording channels, perhaps with little or no modification of current video equipment. Such a technique is possible if a TV signal contains predictable patterns or redundancy, since either implies that less than all the available information bandwidth is being used. The mechanism of black-and-white and of color television as well as some of the physical and psychological aspects of vision allows a nearly orthogonal system to be put in the cracks between the video information, at least theoretically. Orthogonality of such a system allows it to work both ways—the data stream must not render the picture unwatchable (and ideally would not affect the picture in any way), and the data should not have interference caused by the electronic representation of the picture. To measure these effects, it is necessary to build a demonstration system and evaluate the results with known data signals and pictures representative of what might be seen by a camera in such a system. A measure of success would be that, for example, a data signal that is 20 decibels below the peak picture signal would cause a subjective degradation of the video signal comparable to a signal-to-noise ratio greater than 20 decibels.

Because the system described herein transmits data and video simultaneously (in contrast to systems that transmit signals at the edges of the screen, cause lettering to appear superimposed on the screen, or modify synchronizing pulses), an examination of the entire television system format is required. This report discusses the characteristics of black-and-white and color TV systems; examines the implications of existing TV systems to determine what additional information can be transmitted without interference; and considers the realization of the modulator-demodulator (MODEM), the carrier generator, and other hardware. Additional considerations are presented toward further refinements to reduce subjective video interference. Appendix A describes a convenient method of generating data subcarriers.

A videotaped presentation explaining and demonstrating the system is available from NWC, Code 6243. The presentation is formatted for International Videotape Corp. 1-inch helical scanning color or black-and-white players.

BLACK-AND-WHITE TV SYSTEMS

Although more than one type of black-and-white TV system is in use today, all systems have certain attributes in common:

1. All systems use some type of scanning system that lights only one point on the display at a time.
2. All commercial broadcasting systems use horizontal lines, although the number of pictures transmitted per second and the picture shapes vary.

The U.S. commercial system is named after the National Television Systems Committee and is known as the NTSC system.¹ It has been in use in the United States since the 1940s and is also used in Mexico, Canada, and Japan. The NTSC format was amended in 1953 to include compatible color standards.

The NTSC system uses an aspect ratio (ratio of picture width to height) of 4:3, chosen because it was the motion picture format of the 1940s. It also corresponds to what Greek philosophers considered to be the most pleasing shape for a rectangle. Since older television sets had round kinescope screens, only a portion of the transmitted picture was seen in the home.* Until roughly 1970, normal kinescopes were made to the ratio 5:4, and adjusting the picture to just fill the face of the kinescope resulted in people being somewhat taller and skinnier than in real life. Recognition by the TV receiver industry of the actual aspect ratio resulted in the 25-inch (635-millimeter) kinescope, which is the same height, roughly 15 inches (381 millimeters), as the 23-inch (584-millimeter) kinescope, but wider. Most home receivers are adjusted to slightly overscan the kinescope with the received picture, especially since the first few lines of a commercial TV picture contain a series of dots and dashes used by the station, the network, and the telephone company for testing, which are distracting especially on dark scenes.

NTSC SYSTEM CHARACTERISTICS

An NTSC picture consists of 30 frames (number of pictures transmitted or projected per second), each consisting of 525 lines. Since a vertical sweep rate of 30 would be easily perceptible to the eye, each frame is transmitted as two fields containing 262 1/2 lines apiece. The first field starts with the electron beam at the top left-hand edge of the picture, travelling to the right and sloping down slightly. When the beam reaches the right-hand side of the kinescope, it is blanked (i.e., it emits no light) and rapidly retraces over to the left. The total time spent getting from the left-hand edge to the left-hand edge again is 63.5 microseconds, 52.4 of which are spent in tracing the picture, and the other 11.1 microseconds in "horizontal flyback". When the beam is unblanked again, it is on the left-hand edge of the picture slightly below the point at which the first line began. This procedure continues until the beam is halfway through the last line at the bottom of the picture, at which time it is blanked for an integral number of lines (normally 19, 20, or 21) and returned to the top of the screen; this is called "vertical blanking" or the "vertical retrace interval".

Because the blanking interval is an integral number of lines, and since blanking started in the middle of a line, the beam is then unblanked in the top center of the screen. Since each horizontal line is angled down slightly, the half line generated by the beam is slightly above the line generated at the start of the sequence. The next line generated, for the same reasons, falls between the first and second lines in the first vertical scan, and this interlaced scanning continues until the last line of this second field is finally blanked for the last time at the bottom right-hand edge of the picture, ending the second field and completing the first frame. The beam reappears at the top left-hand edge of the screen, and the whole procedure starts again. This roundabout method of transmitting a picture is used so that the vertical rate is double what it would be if all lines were sent in order from the top to the bottom. In this manner flicker that would otherwise result is eliminated.** Unfortunately, pictures of things that are moving with respect to the screen appear to have jagged edges. Also, since a finite time is taken in sweeping from top to bottom and left to right, object shapes are distorted by motion. For instant replay, a single field is displayed twice to prevent doubling of those items in motion. If extremely rapid motion is expected, a camera equipped with a shutter that opens for a short time during the vertical blanking interval stores the picture to be removed while the shutter is closed.

*Because early kinescope screens were round, rectangular screens are measured between diagonal corners, e.g., 25 inches, overall diagonal measure.

**In motion picture projection, each of the 24 frames projected in a second is projected three times, for an effective flicker frequency of 72 hertz.

¹National Television Systems Committee. *Television Standards and Practice*. New York, McGraw-Hill, 1943.

Although there are 525 lines in each frame, at least 19 and perhaps as many as 21 of the lines in each field are blanked during vertical retrace. Thus the number of active lines on the screen is between 483 and 487, nominally 485.* If the smallest picture element is a dot (as opposed to a dash), each horizontal line would need to consist of $4/3$ (due to the aspect ratio) times 485 elements, or $646\ 2/3$ elements. A horizontal line is analog in nature (i.e., continuous, whereas a vertical "line" is made of a countable number of dots). Since the signal feeding the scanning beam is band-limited, the smallest horizontal details are represented by sinusoids rather than square waves. Each cycle of the sinusoid represents two picture elements: a black one and a white one. Thus a horizontal line could potentially contain $323\ 1/3$ cycles; since the line is 52.4 microseconds long in the unblanked period, a passband of 6.16 megahertz would be required. The most detailed picture imaginable would consist of a checkerboard pattern 485 squares tall, $646\ 2/3$ squares wide, and tilted down slightly on the right side. If this pattern were generated by taking a card with the pattern on it and pointing a camera at it, however, several problems could result. First, since the scanning beam in the camera is not infinitesimal, some blurring will result in both the vertical and horizontal directions. In the horizontal direction some of this blurring can be eliminated by adding high-frequency peaking to the camera output—the result being an enhancement of picture detail. Vertical enhancement is considerably more difficult, however, since to perform such an operation, any line must be compared to the line above and below it—and the line to either side of any given line occurring in the previous field, roughly $1/60$ of a second earlier, and would have to be stored without serious degradation or jitter.**Additionally, even if the camera were in perfect registration with the pattern, a slight amount of motion up or down would cause the scanning beam to no longer track the rows of the checkerboard, but rather to integrate in the crack between them, rendering the picture gray. If the checkerboard were tilted slightly out of position, the checkerboard would still be visible in places on the screen and gray on others. Clearly, then, due to the "sample" nature of the vertical direction, some degradation not directly attributable to frequency response results and by its nature is not clearly analytical. For normal subject matter, average viewers rated vertical resolution as degraded to about 70% of ideal,² thus a more accurate measure of vertical resolution is about 339 lines. Optimum resolution in the horizontal direction is then 452 lines, and the required bandwidth is 4.3 megahertz.

NTSC broadcast standards restrict the bandwidth of the transmitted video signal to 4.2 megahertz; additionally the sound signal is transmitted at 4.5 megahertz, above the picture carrier, so the receiver must effectively not respond to the sound carrier.***A signal could be postulated, perhaps generated in a computer, that takes full advantage of the 485-line vertical response capability and for full resolution would also require the 6.16 megahertz derived earlier. Obviously, such a picture would clearly be degraded in the horizontal (but not the vertical) direction by the reduced bandwidths of the transmitter and receiver. On the other hand, given digital techniques available today, it would be possible to transmit twice the resolution described previously by using a 4:1 interlacing and starting half the horizontal lines half a dot-space to the right of the others, and still remain compatible with existing receivers. Such schemes involve the assumption that the detail information (high frequency information in the horizontal direction and rapid brightness level changes in the vertical) represents only a small portion of the total picture energy. However, the present TV system compares favorably with film as a video display medium—an observer of a kinescope can easily see the degradation of a picture originating from film instead of from a live (or videotaped) source, and can usually determine whether the film source was 16- or 35-mm film. On the other hand, film made from TV pictures does not appear to be seriously degraded.

*Since TV standards were formed before digital techniques (in fact, before transistors), countdown methods for interlocking vertical and horizontal signals were never required; thus the blanking interval is not necessarily an integral number of lines.

**Actual vertical aperture enhancers, also called "crispeners", operate between adjacent lines of the same field, generally improving the picture but at times causing odd and unpleasant effects.

***The sound subcarrier frequency is selected to be less objectionable than it would have been if selected arbitrarily. (See section on interference-free data transmission.)

²Bell Telephone Laboratories. *Transmission Systems for Communications*. Winston-Salem, N.C., Western Electric Company Technical Publications, 1970.

GENERAL TELECINE SYSTEM CHARACTERISTICS

In telecine systems, motion-picture film is projected onto or into a camera made specifically for that purpose. Since the standard sound film speed is internationally set at 24 frames per second and the NTSC television standards call for 30 frames or 60 fields per second, a 3-2 shutter is used on the film projector. Thus, three fields are scanned of one frame, then two of the next. The jerkiness caused by the 3-2 shutter is not obvious to the viewer. Also not obvious to the viewer is the result of a video-to-film transfer, wherein only 5/6 of the total video information is extracted. The shutter of the kinescope recording camera is set to be open exactly 1/30 second. During this interval, exactly one frame of the TV picture is recorded: the remainder of the field being traced when the shutter opens, the entire next field, and the first part of the following field. If shutter speed is slightly less than 1/30 second, some lines will be missing from the picture; if the shutter is open longer, some lines are photographed twice and appear twice as bright. Given present-day digital counting techniques, a kinescope recorder whose shutter speed is longer than 1/30 second operated with a kinescope whose picture is unblanked only for the proper number of lines can be employed. In the European TV systems, where a 25-frame/50-field system is used, a transfer to film which is then played back on either European or NTSC telecine systems has incredible jerkiness. Likewise a conversion from European standards to NTSC or the reverse is apparent to some viewers. The problem in all conversions is that a continuous, analog event is sliced into arbitrary vertical chunks and time segments; to change the number of chunks or segments involves repeating something or leaving something out, either one at a rate apparent to the viewer.

COLOR TV SYSTEMS

Color TV standards were adopted in the United States in January 1954. The system authorized at that time and still in use is compatible: a color transmission viewed on a monochrome (black-and-white) receiver provides a high-quality black-and-white picture representing normal brightness values, and a color receiver receiving a monochrome signal produces a monochrome picture. The NTSC color system requires no additional bandwidth, indicating that chrominance information can be put somewhere in an existing black-and-white frequency spectrum where it does not interfere markedly with the black-and-white picture seen on an unmodified black-and-white receiver, and yet be separable in such a way that the chrominance signal is not disturbed by the presence of the luminance (black-and-white) signal. This is of interest in this discussion, since it demonstrates that there is orthogonal space in the black-and-white (but not necessarily the color) spectrum.

COLOR PICTURE PROJECTION

To produce an acceptable color picture with a projection system, a minimum of three colors must be used: blue, red, and green. Yellow, for example, is produced by equal amounts of red and green in the absence of blue; the three together produce white; the absence of all three produces black; red with some blue and green produces pink. The color response of the eye is not so easily categorized, but a three-color projection produces sufficient color information to satisfy the eye (and the brain) that a picture consists of all the colors present in the original scene. To reproduce such a three-color picture in its entirety would require three transmission channels, each 4.2 megahertz wide, and arranged in such a way as to arrive simultaneously and be synchronized. Original experiments with color TV (and earlier, with color film) determined that the eye is not so sensitive to color differences as it is to differences in brightness. Thus, if brightness information could be separated from color information, the color information could be transmitted more crudely with little or no degradation apparent to the viewer.

One early system was the Columbia Broadcasting System, which involved a monochrome kinescope with a rotating filter wheel placed between its face and the observer. The black-and-white picture appearing on the kinescope at any given moment was as photographed through a filter of the same color as the filter at the receiver. If black-and-white standards had been used for such a picture, given the interlace of odd and even fields, a complete, color, 525-line picture would be generated 20 times a second. If any item in the scene were fully saturated (full red, for example) it would flicker at a rate of 40 times a second, a flicker rate easily perceptible as a brightness (if not a color) variation. To accommodate this problem, CBS proposed a picture consisting of fewer lines and a higher field and frame rate. Unfortunately, such a system was then rendered incompatible with existing monochrome standards, since the normal receivers are not capable of locking to radically different line and frame rates. Additionally, if the receiver could be made to lock to the new color sync standards, the picture viewed without the wheel would transmit to the eye of the viewer a black-and-white picture where the gray-scale values of red, green, and blue would all be seen with equal intensity, whereas the eye has strongest sensitivity to yellow and green, with relatively less sensitivity to red and very low sensitivity to blue. Added complications arise in the manufacturing of a rotating-wheel system for 25-inch (635-millimeter) overall diagonal measure kinescopes.

BANDWIDTH COMPRESSION OF COLOR INFORMATION

Most of the systems proposed earlier involved transmitting three pictures: one each of the three primary colors, red, green, and blue. Since, as described earlier, a standard black-and-white picture requires a bandwidth of 4.2 megahertz, it follows that transmitting three pictures for color would require 12.6 megahertz, more than twice the 6-megahertz bandwidth allotted to black-and-white stations. Fortunately, however, advantage can be taken of the characteristics of the eye to reduce the required bandwidth significantly. Unlike color film, for example, the color response of the eye appears to be somewhat continuous—thus the light from a fluorescent source is regarded by the eye as white, and a photograph regards it as blue-green. The color receptors in the eye have considerably lower resolution than the contrast receptors. To illustrate the latter statement, consider three sets of stripes, the first consisting of vertical stripes of black and white such as those in Figure 1, the second of blue and red, and the third of green and purple. If the three sets are viewed from the distance where the green and purple stripes have merged into a single, brownish color, the red and blue and the black and white stripes are still easily distinguished. At the distance at which the red and blue stripes merge, the black and white stripes are still visible. Because of this the electronic description of a color scene can consist of a brightness (black-and-white) signal and two color signals, each of which has lower resolution than the black-and-white signal, describing a red-to-blue axis and a green-to-purple axis. Any dot on the screen is then produced by a combination of three primary colors, and the proportions between them are controlled by the brightness signal and the two color signals. The black-and-white signal can be made to be exactly like a standard black-and-white signal, representing only apparent scene brightness, with a bandwidth of 4.2 megahertz, and for color resolution indistinguishable from full bandwidth with a red-blue bandwidth of 1.5 megahertz and a green-purple bandwidth of 0.5 megahertz. Thus the two color signals now represent only a slightly less than 50% increase in required bandwidth, rather than three times the black-and-white bandwidth as before.

Since the two color signals have something in common, i.e., they both describe aspects of coloriness (rather than brightness, as does the wide-band signal), and are related to a color chart in a specific way, they can be combined on a single carrier. If such a carrier were generated both in a reference (arbitrary) phase and also shifted 90 degrees, and one of the signals were modulated by the red-blue signal and the other by the green-purple signal, the signals could be separated by a similar demodulator at the receiver. If double-sideband modulators are used, a signal with brightness but no color would be represented by no subcarrier. If the receiver is in some way locked in phase to the reference oscillator and the red-blue modulator connected to the reference phase, a red object would be represented by a signal in phase with the reference, a blue object by a signal 180 degrees opposed to the reference, a green object by a signal 90 degrees ahead

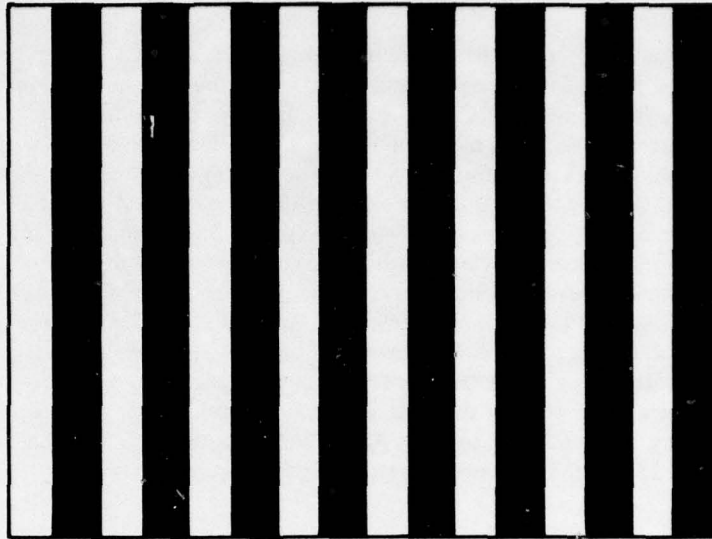

FIGURE 1. Black-and-White Stripes for Comparison With Color Stripes to Test Eye Resolution.

of the reference, and a purple object by a signal 270 degrees ahead (or 90 degrees behind) the reference. In this system, then, a blue-green object would be represented by a signal 135 degrees ahead of the reference, and in fact any phase shift would represent some color on the color chart. The absolute amplitude of a subcarrier so constructed would be proportional to saturation; thus a pink object would be represented by a subcarrier of the same phase as a red object, but the subcarrier amplitude would be lower. The actual color vectors used in NTSC color television are not exactly those shown, one reason for which is that the red-yellow-green area is spread over a larger region of the reference circle (color chart) so that fine distinctions can be made in the area of flesh tones, which are regarded by the viewer as more critical than exact shades of blue and purple. Diagrams of a modulator and of a color chart with the color subcarrier axes are shown in Figure 2.

Since the screen on the receiver is blanked (black) during all times when picture information is not being transmitted, the color subcarrier has zero amplitude at these times. Thus it is possible to transmit a reference phase during the blanking interval for the color demodulator oscillator in the receiver to lock to. This signal, called "burst", occurs in the horizontal blanking interval after the horizontal sync pulse but before the end of horizontal blanking, and consists of eight pulses of the subcarrier at reference phase. No burst signal is transmitted during vertical blanking.

COLOR SUBCARRIER CHARACTERISTICS

The frequency of the color subcarrier remains to be determined. Since the sound carrier is transmitted as a 4.5-megahertz subcarrier, a color subcarrier could be placed above the sound. Monochrome receivers would then simply not be of wide enough bandwidth to detect the color signal, and compatibility would be assured. However, adding a subcarrier above the sound carrier would necessitate increased bandwidth for color signals, meaning that channels would be farther apart and consequently fewer in number. Fortunately, another possibility exists: since monochrome TV receivers seldom take advantage of

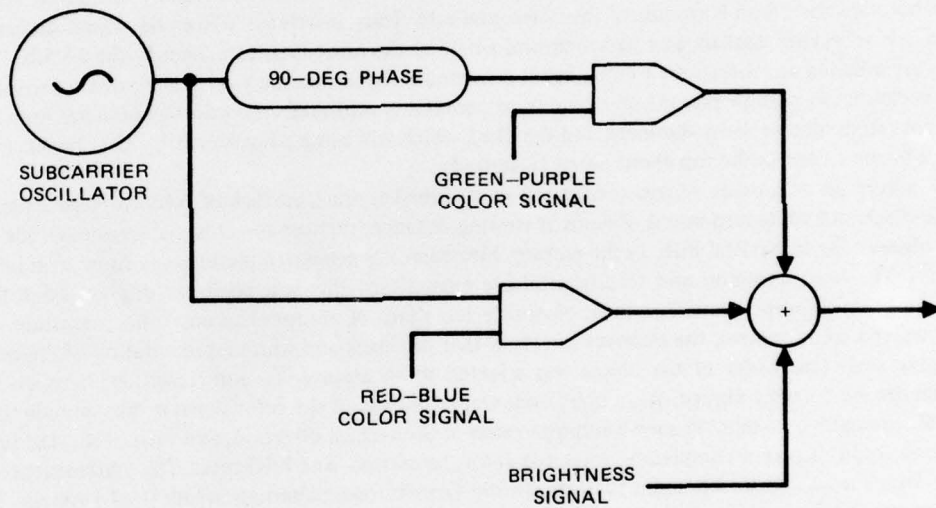
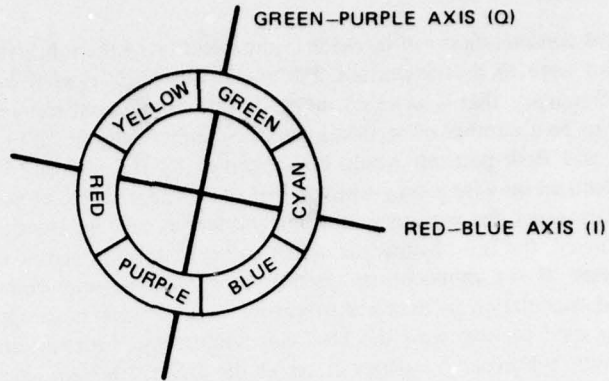

FIGURE 2. Top: Color Axes (Approximate) for NTSC Encoding; Bottom: NTSC Compatible Color Modulator.

the full bandwidth transmitted, but instead commence a high-frequency rolloff above 2.7 to 3.5 megahertz, a subcarrier between 2.7 and 4.5 megahertz would have minimal impact on such receivers. Since (except for the color-synchronizing signal) no color subcarrier is transmitted during blanking intervals, a subcarrier in the passband of the set would have no effect on the capability of the monochrome receiver to establish sync references. On wide-band receivers, of course, a subcarrier of this nature arbitrarily selected would still be visible as a herringbone pattern.

One additional consideration can be made in the selection of the subcarrier frequency. If a picture of a uniform gray card were to be transmitted, and mixed with such a signal was the output of a function generator set to a frequency that is an exact multiple of the horizontal frequency, the resulting combination would appear to be a number of vertical lines (the number determined by the multiple). The contrast between the light and dark portions would be controlled by the intensity of the signal added. If the generator were instead set on a frequency which is half of an odd multiple of the horizontal frequency (i.e., an *n*-and-a-halfth harmonic), the pattern would be considerably less apparent at any injection. The higher the oscillator frequency, the less obvious the added pattern becomes, and at some frequency the pattern completely disappears. If the monochrome picture being sent is more complex than a gray card, the masking is improved; modulation on the color subcarrier makes it again more apparent, but the variations in the color subcarrier tend to vary with the black-and-white subject matter, and are again masked.³ For NTSC color, the color subcarrier frequency is set at the 227 1/2th harmonic of the line horizontal frequency. With this frequency selected, the lower sideband of the color subcarrier can extend over the entire 1.5 megahertz band without attenuation, but only the lower 600 kilohertz or so of the upper sideband of the color subcarrier is present, causing some reduction in color detail. Standard home receivers have both color axes limited to 600 kilohertz, but studio monitors normally can extract the additional color detail present on the wider-band in-phase ("I") component. To prevent interaction of the sound subcarrier with the demodulator of the color subcarrier, the horizontal oscillator rate is lowered slightly so that the sound subcarrier becomes the 286th harmonic of the horizontal rate. Thus, interference from the sound subcarrier onto the color subcarrier appears as a harmonic-and-a-half of the horizontal rate, namely the 58.5th. If all tolerances are adhered to, therefore, a color signal is immediately recognizable on a black and white set by the fine checkerboard pattern present on those areas containing saturated colors and by 60-hertz hum and noise present (from motors, lamp dimmers, and the like), which will cause a horizontal bar that travels from the bottom of the screen to the top about every 16 seconds.

The limitations of a color system configured as described are that the lack of color response equal to that of the black-and-white response is obvious at viewing distances that are too close—close enough for the viewer to observe the horizontal lines in the picture. Electronically generated pictures can show such limits quite easily. The most common and readily available example of this is a color-bar display, since that display has a green-to-purple transition in it, obviously less sharp or abrupt than any other transition. By turning down the color control, the observer can show that the black-and-white representation of the color bars is a gray scale (the order of the colors was selected to so arrange it), and transitions between the different shades are suitably abrupt. Although horizontal resolution of the color signal is thus quite limited in the NTSC compatible system, no such limitation exists in the vertical direction, and each of the 485 lines on the screen could display a completely unrelated color, saturation, and brightness. This statement is not necessarily true for all compatible color systems. In the German phase-alternation-line (PAL) system, the 90-degree phase shifter in the color subcarrier generator switches from 90 degrees leading to 90 degrees lagging and vice versa at the end of each line. By using this arrangement, it is possible to produce a receiver that can correct phase errors that may occur in transmission, making the tint control unnecessary. Receivers for PAL that do automatic tint correction have a delay line that compares color from one line to the next, and since the two lines compared have another line between them in the next field, resolution is reduced in an obvious but not easily quantizable way.

³John Wentworth. *Color Television Engineering*. New York, McGraw-Hill, 1955.

COLOR PICKUP SYSTEMS

The most direct way to generate the green, red, and blue signals for a color system is to have three pickup tubes look at the same scene through the same lens, each adjusted to scan the same portion of the scene at the same time. This requires not only synchronization of the scanning beams, but also adjustment of the individual sweep voltages so that each tube's picture size, position, rotation, and linearity is identical. Since the black-and-white (luminance) signal is made of portions of each of the three signals, any misalignment between the three tubes causes a double or even triple image on the black-and-white receiver and color fringing around white objects, as well as loss of resolution in color. Additionally, since splitting the light entering the lens three ways reduces the light falling on each tube, the required lens speed and required lighting is increased. Another variation is to split most of the light to a large orthicon tube that has no filter--a black-and-white pickup--and the rest of the light to three vidicon tubes whose resolution is more limited, from which the color signals are formed. The advantage of such a system is that the black-and-white signal depends upon only one tube, and resolution of the color pickups is not as critical. Some three-tube pickup systems use only red, white, and blue pickups--the color signals can be derived from that combination. The effects of misalignment of the three tubes can also be minimized by limiting the frequency responses of the red and blue channels and adding excessive high frequency response on the green channel (which represents 60% of the black-and-white signal). Although this method is effective in most cases, certain subject matter causes strange effects.

The use of only one or two tubes, however, reduces the size and weight of a color television camera, and simplifies alignment of the colors as well. Color TV pictures returned from the moon used a single-tube camera with a rotating filter. To make such a picture compatible with standard receivers, a disc storage unit was used to hold two preceding fields. At any time, then, a picture could be constructed from the live input and the last two from memory, combining all three to make a single color picture. If a white object were to move rapidly from one side of the picture to the other, it would be represented by red, green, and blue patterns in rapid succession. Ampex produced a portable camera with two tubes, one of which had a red-blue rotating filter, and involved a single-field storage to produce three colors for encoding. Since the Ampex camera was intended for use in, for example, sports remotes, it is seldom used at present, since a stop-motion "instant replay" frozen frame has double images due to the reconstruction of the color.

COLOR TRANSMISSION/RECORDING CHARACTERISTICS

Transmitting or recording an NTSC color signal requires a bandwidth of at least 3.6 megahertz, since the lower sideband of the color signal and the subcarrier must be preserved. If, as in the case of lower-cost videotape machines, a bandwidth less than 3.6 megahertz (sometimes considerably less, such as 1.5 megahertz) is available, the color signal as well as the black-and-white signal must be adjusted in some way so that upon reconstruction the picture resembles a normal black-and-white or color signal when played into a standard receiver. Black-and-white recorders handle this quite readily: only every other field is recorded--just the odd or even fields, and each is played back twice. This cuts vertical resolution in half, since the 485-line picture now consists of only 243 pairs. Horizontal resolution is cut by half by the high-frequency roll-off of the input. Since vertical and horizontal responses are similarly degraded, the picture appears to be less sharp than the original, but not obviously degraded by containing only 25% of the original information. The now-defunct Cartrivision system records every third field, but has a bandwidth

sufficient for color. In systems like the Sony Videocassette system, the color subcarrier and some of its sidebands are heterodyned to a lower frequency for recording, and heterodyned back on playback, with filtering to prevent resolution and delay problems. Broadcast videotape recorders, which cut each field into 16 pieces and reconstruct them on playback, are extremely susceptible to creating phase shifts on the color subcarrier on playback. A timing error of 140 nanoseconds, for example, in the switching between one head and the next, can cause a color shift from red to blue. Electronic correction is employed in such recorders to reconstruct the color signal to remove these errors. Imperfect correction can be occasionally seen on home receivers where a background color (especially red) has bands or lines that appear off-color.

When color TV is transmitted as AM, as it is in commercial practice, over-the-horizon pickup can cause fading on some parts of the signal and not others, causing color information to be of improper magnitude in relation to the brightness signal. If not severe, this can be corrected by readjustment of the color controls, if severe, equalization of the detected video signal is required. Problems can come from unexpected sources—standoff insulators fully crimped around the antenna wire at a spacing of 6 feet (1.8 meters) attenuate color on channel 6 extremely yet provide a good quality black-and-white signal. Nonlinearity in the transmission medium can cause a beat note between the 4.5-megahertz sound subcarrier and the 3.58-megahertz color subcarrier. This beat note is (approximately) 920 kilohertz, which is (for reasons mentioned earlier) one of the frequencies that is less apparent on the screen than others. However, since the sound subcarrier is frequency-modulated, if any sound is present, the beat note is readily apparent as a moving tweedlike pattern. Since the pattern is variable, it would be difficult if not impossible to trap from the picture without introducing distortion.

Because of the subcarrier used in color TV, the possibility exists that some item in the picture to be encoded has lines or edges already in it that when swept by the scanning beam(s) could cause an apparent subcarrier to be generated. This can be observed in a commercial TV picture when someone shown on screen is wearing a tweed or finely checkered item of clothing. When the pattern is near critical size, the resulting effect on a color receiver is for the pattern to be surrounded by and to contain rainbowlike signals not present in the original. Most such interference can be eliminated by filtering the individual color pickup signals to notch out frequency content in the region of 3.58 megahertz before color encoding. The result of such filtering is to cause an item that would otherwise cause trouble to appear slightly out of focus, or simply gray.

The significance of color TV in weapon systems, of course, is that a color display contains more information than a black-and-white display. Whether the added color simply adds lettering to the screen or a full color display of the scene is used, readability is increased. Although the colors in the display kinescope are factory-fixed and nonnegotiable, nothing prevents the colors used in taking the original picture from being infrared, yellow, and turquoise if such an arrangement can increase contrast. Color displays can even be produced from black-and-white camera outputs by making each of several levels of gray appear as a different color. Such systems are used, for example, in examining X-ray photographs.

INTERFERENCE-FREE DATA TRANSMISSION

In order to allow space for a data signal to be added to the electronic representation of a TV picture, unoccupied space in the TV signal must be isolated and separated from that which produces the picture. This, of course, assumes that a TV picture contains less information than allowed by the bandwidth provided for it. Given the bandwidth and timing described for black-and-white systems, each of the 485 unblanked lines can contain 440 individual dots, so that a total of 213 400 picture elements (pixels) can be

generated. (Since horizontal lines are continuous in nature, even this figure understates the total capacity.*) At a frame rate of 30 per second, the signaling rate is thus 6 402 000 pixels per second. Since a bandwidth of 4.2 megahertz is provided for TV, which would allow a maximum of 8 400 000 pixels per second, the difference of nearly 2 million pixels is lost in the space provided for synchronizing the receiver to the transmitter. Each pixel is capable of being any shade of gray from black to white (color will be discussed later), and the number of shades of gray are limited only by the number of shades detectable by the eye and the signal-to-noise ratio of the TV system. Since a 40-decibel signal-to-noise ratio appears sufficient, corresponding to a 1% voltage variation on the signal, and since the gray scale is roughly 75% of the total signal, each pixel could be divided into one of 75 shades, indicating that each pixel could be represented by 6.22 digital binary bits (also called Shannons). Thus, if every pixel were independent of every other pixel, a kinescope used as a data display could display 39.82 megabits per second without overloading the data channel. However, if such an arrangement were made, the eye of the observer would be overloaded, and the picture would resemble the appearance of the kinescope face when the receiver is tuned to a blank channel. Such a picture is regarded by the observer as noise—which in fact it is. Clearly then, there exists some interrelation between pixels, indicating that the entire data capacity of the TV channel is not used. A TV system that transmitted only the differences between adjacent (vertical, horizontal, and even diagonal) pixels, and the changes in brightness between frames of the same pixel could be designed, but the saving in bandwidth would be at the cost of extremely complex transmitting and receiving apparatus. Fortunately, a number of the redundancies are easily detected through mathematical analysis, and the same analysis suggests a possible orthogonal set of data channels.

TV SIGNAL REDUNDANCY

The redundancy in the TV signal is due to several factors. (1) Since adjacent fields are interlaced, the signal on them is nearly identical. (2) Any horizontal line is similar to the one above or below it, and any pixel in a horizontal row is similar to the pixel on either side. (3) Neglecting a complete scene change, or cut, any two successive frames are nearly identical, even if all or part of the scene is moving. (4) Dependencies are forced by the limitations of the medium—the scanning beam in the camera is not infinitesimal, which decreases resolution; some pickup tubes do not completely erase when scanned, so subsequent scans contain some information from previous events; the source of some pictures is more limited than the system used to scan it (for example, photos made from 16-mm film, or 16-mm film itself). (5) The repetition rate of the input may be fixed at a lower rate than that of the output, as in motion picture film, since the film is projected at a 24-frame rate and the TV output is at a 30-frame rate—thus 20% of the TV signal could be constructed from repetitions of previous frames or fields.

The electrical signal produced by a TV picture of a stationary scene repeats itself exactly 30 times a second. From Fourier analysis it can be shown that all the energy in a stationary picture is contained in harmonics of 30 hertz, plus a DC term. In a 4.2-megahertz pass band, 140 000 such harmonics can be placed. The relative amplitudes of the harmonics decrease as frequency increases, the rate of decline determined by the amount of detail in the picture. Since each frame consists of two fields that are nearly identical, the harmonics that are multiples of 60 hertz (that is, the even harmonics of 30 hertz) predominate. Although it is less obvious, it has long been known that since horizontal lines are generally similar, harmonics of the horizontal frequency also predominate.⁴ The horizontal frequency is 15 750 hertz, the 525th harmonic of 30 hertz. The 4.2-megahertz bandwidth can pass 266 harmonics of the horizontal

*Although a horizontal line, for example, could show a system of 200 evenly spaced dots, a vertical display of 200 dots would not be possible due to the quantization caused by the fixed number of lines in the picture.

⁴Pierre Mertz and Frank Gray. "A Theory of Scanning and Its Relation to the Characteristics of the Transmitted Signal in Telephotography and Television". *Bell System Technical Journal*, Vol. 13 (July 1934), p. 464.

frequency. When the scene scanned by the camera contains slanted lines (which would account for part of the lines in a typical picture), more energy would be grouped around the multiples of 15 750 hertz. In general, the 30-hertz harmonics about a multiple of 15 750 hertz appear to be enveloped in a Gaussian shape, as shown in Figure 3.

For any still picture, then, all energy is found at exact multiples of 30 hertz, especially if they are also multiples of 60 hertz and in the vicinity of multiples of 15 750 hertz. For a moving picture, each individual energy spike becomes a small Gaussian distribution. That the distribution should be similar to that of a stationary picture is due to the redundancies between fields, frames, and lines mentioned earlier. Figure 4 is taken from the reference cited in footnote 4, with the horizontal frequencies added that would correspond to present-day television. Note that the actual motion of the subject has negligible effect on the groupings around the horizontal sweep rate. Note also that the somewhat Gaussian distributions around the horizontal rate drop rather rapidly, with considerable space between them. It would be possible, under such conditions, to insert a carrier with data superimposed upon it between two such harmonic groups and separate that data carrier on receiving by feeding the composite signal to a radio receiver tuned to the carrier. Interference caused by the chance occurrence of a TV signal in the area occupied by the carrier could be minimized by using FM or phase-modulation techniques, if required. Since energy distribution in the TV picture falls off with increasing frequency, the subcarrier would encounter least interference (on the average) at the highest frequencies. If the subcarrier were then trapped out of the signal feeding the kinescope, apparently no picture degradation would occur, except that information would be lost in the areas where the tails of the signal and picture distributions overlap, as shown in Figure 5.

EYE SENSITIVITY TO SUBCARRIER CHARACTERISTICS

The eye is more sensitive to patterns that are vertical or horizontal rather than diagonal, and the eye is more sensitive to patterns made of lines than to those made of dots. In Figure 6 all stripes (or checkers) are the same size; thus all patterns should degenerate into gray at the same distance. For most viewers,

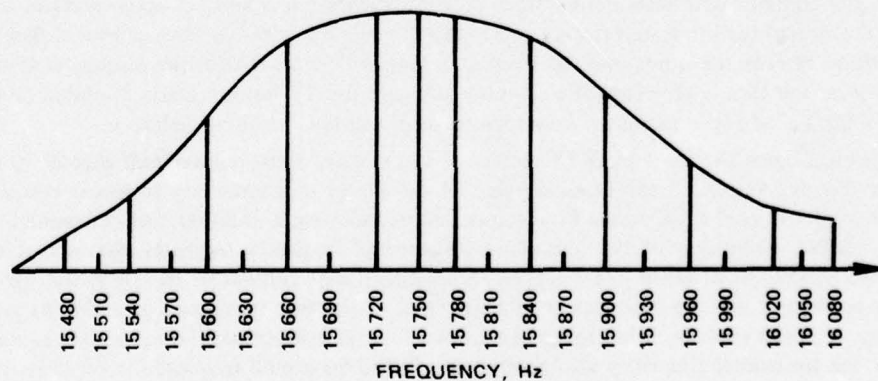

FIGURE 3. Distribution About a Representative Horizontal Line Harmonic.

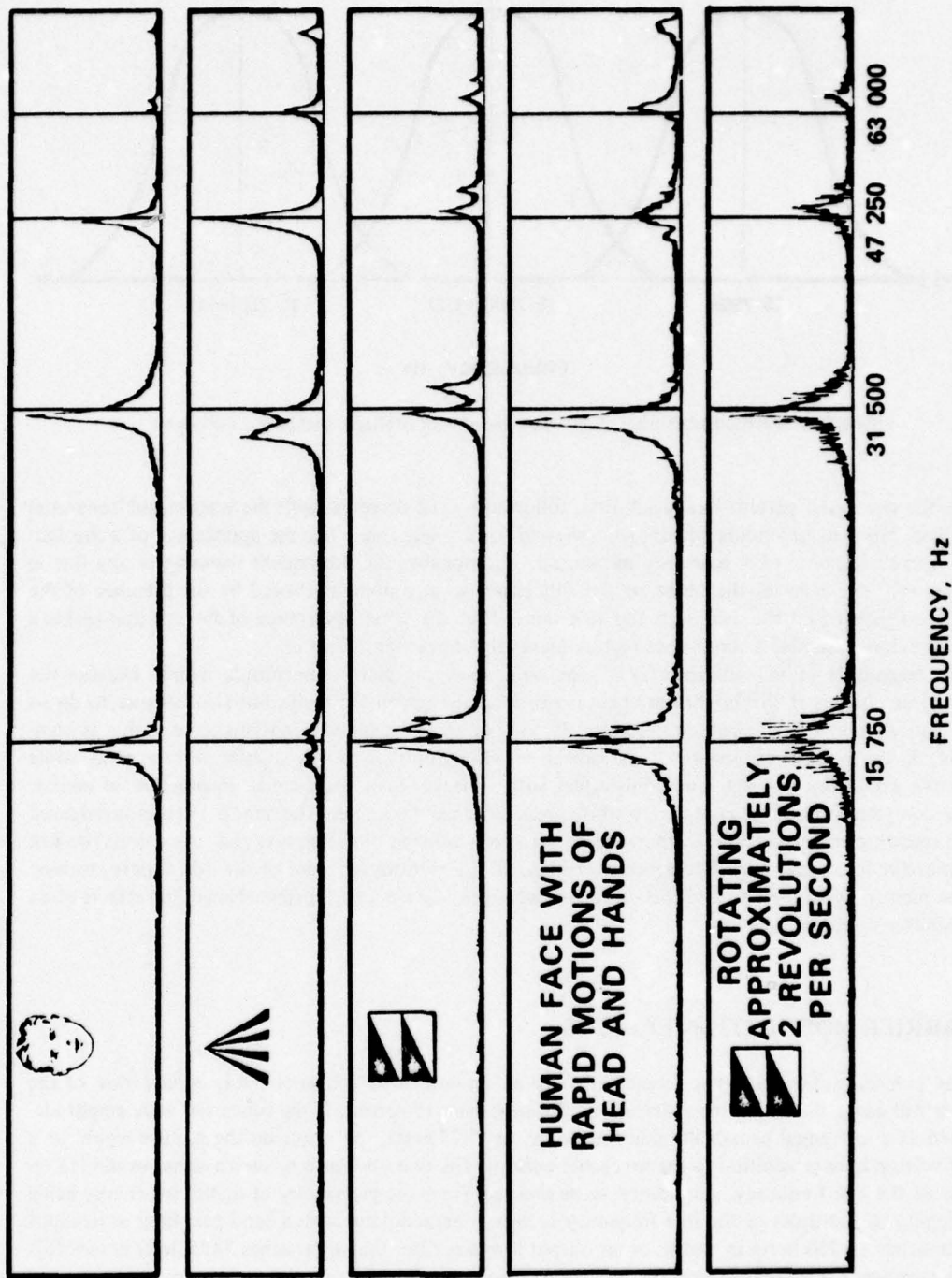

FIGURE 4. Frequency Distribution of Different Types of TV Pictures.

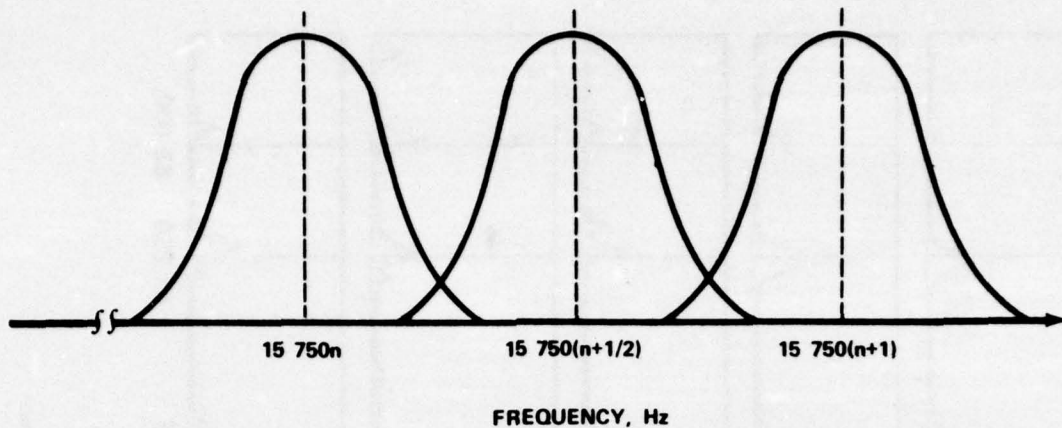

FIGURE 5. Spectral Distribution of Arbitrary Signal With Arbitrary Orthogonal Subcarrier.

however, the checkered pattern disappears first, followed by the diagonal, with the vertical and horizontal patterns last. Since an unmodulated subcarrier viewed for a single frame has the appearance of a checkerboard, the eye's response to it is already minimized. Additionally, the subsequent scanning of any line in the following frame reverses the phase of the subcarrier, so any point darkened by the presence of the subcarrier is lightened on the next scan and vice versa. Thus the same persistence of the eye that makes a scanned kinescope resemble a continuous picture makes the subcarrier disappear.

The magnitude of the subcarrier(s) is kept well below the picture magnitude mainly because the pattern is less obvious if the brightness changes made on the screen are small, but also because to do so prevents cancellation loss at contrast extremes. If, for example, the picture contains an area that is completely black, the positive excursions of the subcarrier will lighten the picture slightly in those areas, while the negative excursions will not cancel this effect with a blacker-than-black signal. In practice, of course, very few completely black or completely white areas exist on the screen. The subcarrier(s) is interleaved with the spectrum of the picture, so the total peak-to-peak voltages of the picture and subcarrier(s) do not add absolutely, but rather in a Pythagorean fashion. If the transmitter were of the AM variety, turning down the picture signal level to add the subcarrier would not cause a perceptible change; the effects of an FM transmitter would be even less.

SUBCARRIER MODULATION EFFECTS

The preceding discussion has considered only an unmodulated subcarrier. Any modulation of the subcarrier will cause the single-line spectrum of the subcarrier to spread. If the subcarrier were amplitude-modulated at a rate equal to half the line frequency, or 7875 hertz, the result on the picture would be a series of vertical lines in addition to the subcarrier pattern. The two sidebands of such a signal would fall on multiples of the line frequency, a condition to be avoided. Since the probability of significant energy being in the vicinity of multiples of the line frequency is high, a demodulator with a band-pass filter at its input that approaches 15 750 hertz in width, or an output low-pass filter that approaches 7875 hertz at cutoff is likely to experience interference from picture information, which will in general increase as the amount of detail in the picture increases. Since the vertical repetition rate of the picture is 60 hertz, the 7875-hertz signal that would appear at the output of the demodulator is modulated by harmonics of 60 hertz, thus energy would appear to a lesser extent at 7815 and 7935 hertz, etc. Clearly, those areas where the spectra of the picture and data subcarrier both exist cause problems for the data demodulator as well as distortion

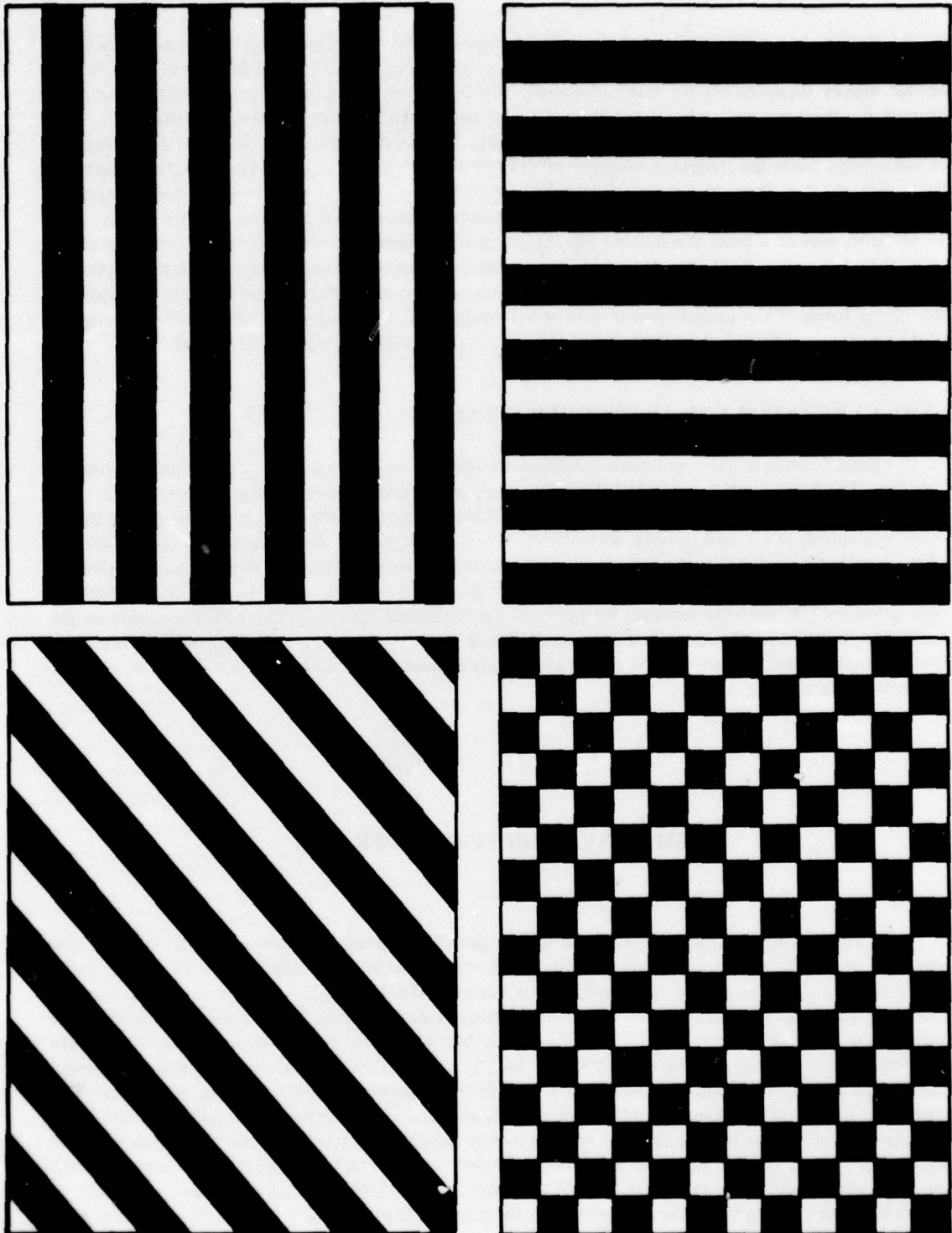

FIGURE 6. Vertical, Horizontal, Diagonal, and Checkerboard Patterns for Eye Sensitivity Comparisons.

to the picture. If a portion of the spectrum were trapped prior to display on the kinescope (or prior to mixing with the subcarriers on the transmitting side), certain types of detail would decrease in amplitude or appear slightly displaced on the screen (normally slightly to the right), and motion would appear more blurred. For these reasons, traps are not normally used, and if used are of very narrow bandwidth.

The requirement that the picture not seriously degrade the data along with the filter response characteristics limits the frequency response of the subcarrier channels to 4 or 5 kilohertz. One possibility for a demodulator, then, is a standard communications receiver. Such a receiver tunes 540 kilohertz to beyond 5 megahertz, thus covering the carrier frequencies of interest, and normally employs stagger-tuned IF filters to provide a 10-kilohertz band pass, resulting in a 5-kilohertz output roll-off. The response of the receiver to the energy bands due to the picture on either side of the subcarrier depends on the amplitudes of the energy, but in general requires that the magnitude of the subcarrier be similar to the magnitude of the energy bands of the picture, give or take about 20 decibels. This is fortunate, since the random nature of the picture would cause the magnitudes of each band to vary with the detail in the picture.

SYNC GENERATOR FOR TV-ENCODER SYSTEM

Figure 7 shows a sync generator modified to operate both a color TV camera and a group of encoders. The division ratios are not approximate—they must be adhered to exactly, or the subcarriers will not interleave properly with the picture information. However, the oscillator could be any frequency within NTSC tolerances, or allowed to drift, without any effect on the picture. The demodulator uses the output of the horizontal oscillator to feed the input to the demodulators if synchronous demodulation is used. As the dashed lines on the drawing show, the subcarrier generator(s) can be added to an existing camera or sync generator. On airborne cameras, for example, the horizontal sync output is usually available on the back plug. In all cases the horizontal sync signal (which is the only input the data encoder requires) can readily be taken from the camera. The output of the data encoder can be added to the camera output either internally or externally.

DEMONSTRATION TV-ENCODER UNIT

To test the theoretical considerations of the preceding sections, a demonstration unit was constructed. Available for the tests were two black-and-white cameras, two color sources (a camera and a film-projection unit), black-and-white and color monitors, and a 1-inch (25.4-millimeter) helical scanning videotape machine. All video sources tested had internal sync generators. The required horizontal sync output was available on the black-and-white cameras, but on neither color source. As a result, all video sources were connected to a Cohu Electronics, Inc., sync generator external synchronization (genlock) input. This generator was not used to generate sync for the sources, but to decode sync from them. This method is employed in places where multiple cameras are used and synchronized to each other (to allow switching the studio output among them without picture jump) and in turn to an external source, such as a network or remote camera. Sync derived through a genlock is by nature less stable than the original source, so if the experiment works with the external generator, operation with the internal source is assured. In addition to the connection to the sync generator, the camera was connected to a video monitor for tests of the subcarrier generator.

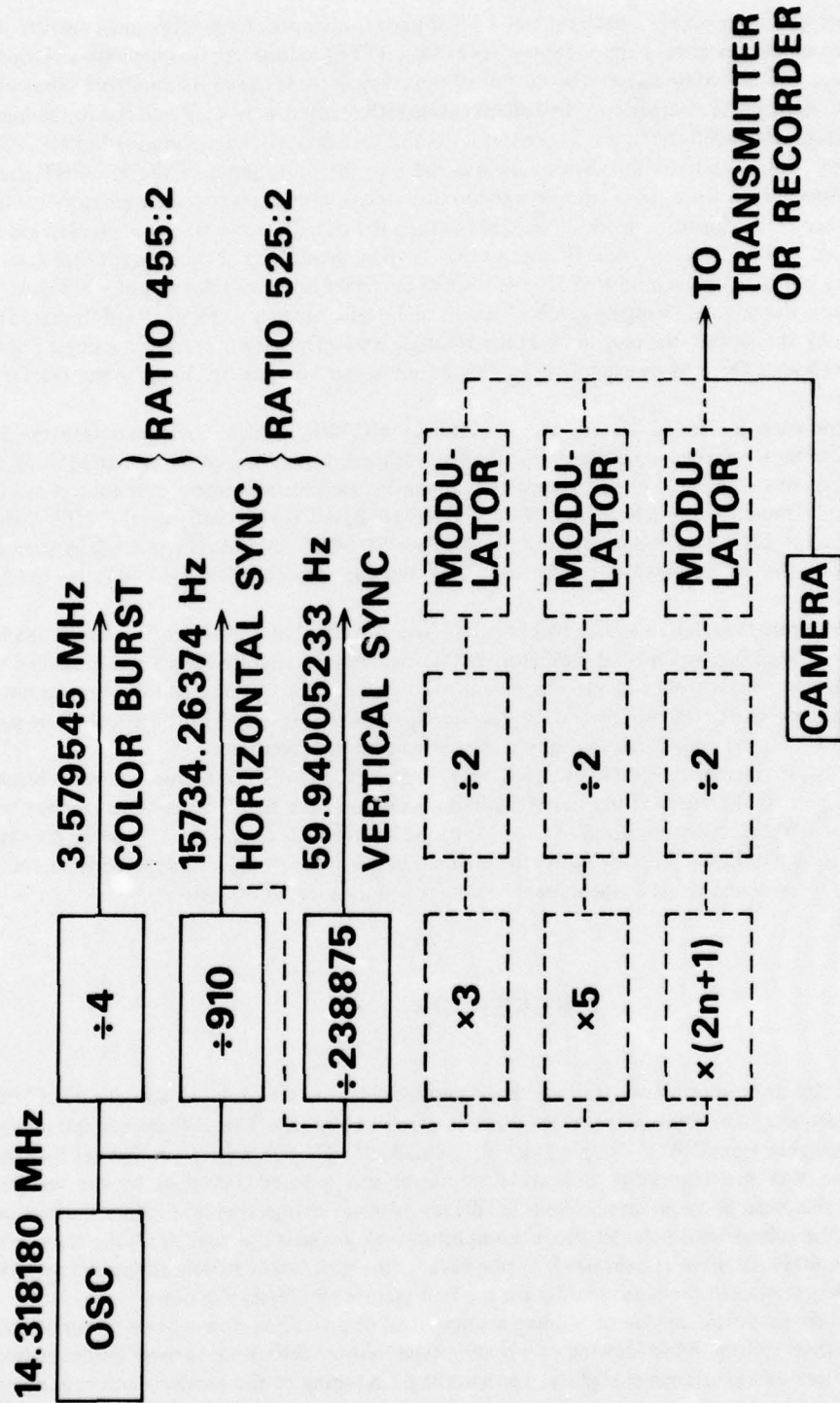

FIGURE 7. Sync Generator Modified to Derive Carriers and Modulators.

The subcarrier generator accepts the nominal 15 750-hertz horizontal frequency and converts the level and impedance of the signal to a transistor-transistor logic (TTL) voltage compatible with a National Semiconductor Corp. LM 339 comparator. The output of the comparator is fed to the reference input of a Motorola Corp. MC 4044 phase comparator. The phase comparator output is filtered and fed to the input of an MC 4024 voltage-controlled oscillator whose output is fed to a divider chain composed of MC 4016 divide-by- N counters. The output of the divider chain is fed into the other input of the MC 4044 phase comparator. (See Appendix A for a more complete theoretical description of phase-lock oscillators.) If the MC 4016 counters are programmed to divide by an odd number, the output of the MC 4024 oscillator is an odd multiple of the horizontal frequency. If this output is then divided by 2 by a toggle flip-flop, a subcarrier frequency of $(2n + 1)/2$ is produced. The subcarrier generator is shown schematically in Figure 8. Figures 9 and 10 show the original "hanging gardens" model and a later model in a plug-in card format. The original layout was by the author, the plug-in by James Webb of NWC. The card operates on a single power supply of +12 to +15 volts DC, and can be made to operate on higher voltages by changing the regulator ballast resistor.

The modulator used for initial testing was a Motorola MC 1496, which is characterized by the manufacturer for use as a balanced modulator (for double-sideband, suppressed-carrier systems) or as an amplitude modulator. Any integrated circuit amplifier that can be used for automatic gain control can be used as an amplitude modulator, such as the Motorola MC 1590, MC 1445/1545, or the MFC 6050; National Semiconductor LM 170/270/370; Plessey SL 640 C or SL 641 C; and others. Multipliers such as the MC 1495/1595 or the MC 1494/1594 can be used also, but care should be taken to pass the carrier frequency.

In the test the input modulation source was provided by a Wavetek function generator, which can be frequency-modulated by an internal second oscillator. In this manner a varying frequency was produced to test whether certain frequencies would be more apparent on the screen than others, and what randomlike signals would do to the picture. One variation of this arrangement used a Western Electric Touch-Tone pad to generate unmusical (i.e., not simply harmonically related) two-tone combinations.

The output of the videotape recorder was fed to a Magnavox color TV monitor, a Conrac black-and-white monitor, and to the antenna input terminals on a Hallicrafters S-38E short-wave receiver belonging to the author. Data recovery consisted of listening to the loudspeaker on the radio. A block diagram of the test setup is shown in Figure 11. Obviously, the medium between the encoder and the decoder could be a transmitter and receiver instead of a videotape recorder, or simply a length of cable.

TEST RESULTS

Tests showed that an injection level (ratio of peak-to-peak video to peak-to-peak subcarrier) of 10% would provide an adequate data signal and unobjectionable picture cross talk. This is demonstrated on the videotape that is available from NWC. Using a small (100-milliwatt) TV transmitter on channel 5 as the transmission medium was also successful. Subcarrier amplitude was reduced 6 decibels by the vestigial sideband filter, and this must be taken into account in adjusting subcarrier injection level. Since the picture energy surrounding the subcarrier is reduced also, the amplitude ratio remains the same. With the videotape recorder used, some 60-hertz noise is generated in playback as the tape heads switch during the vertical blanking interval; optimization of the tape recorder for the best picture minimizes this noise.

The tape recorder used was capable of holding a single field or producing slow-motion pictures—this by continuing headwheel motion while slowing or stopping tape motion. Switching to these modes caused the recorder headwheel speed to change slightly, necessitating a retuning of the receiver, and causing an

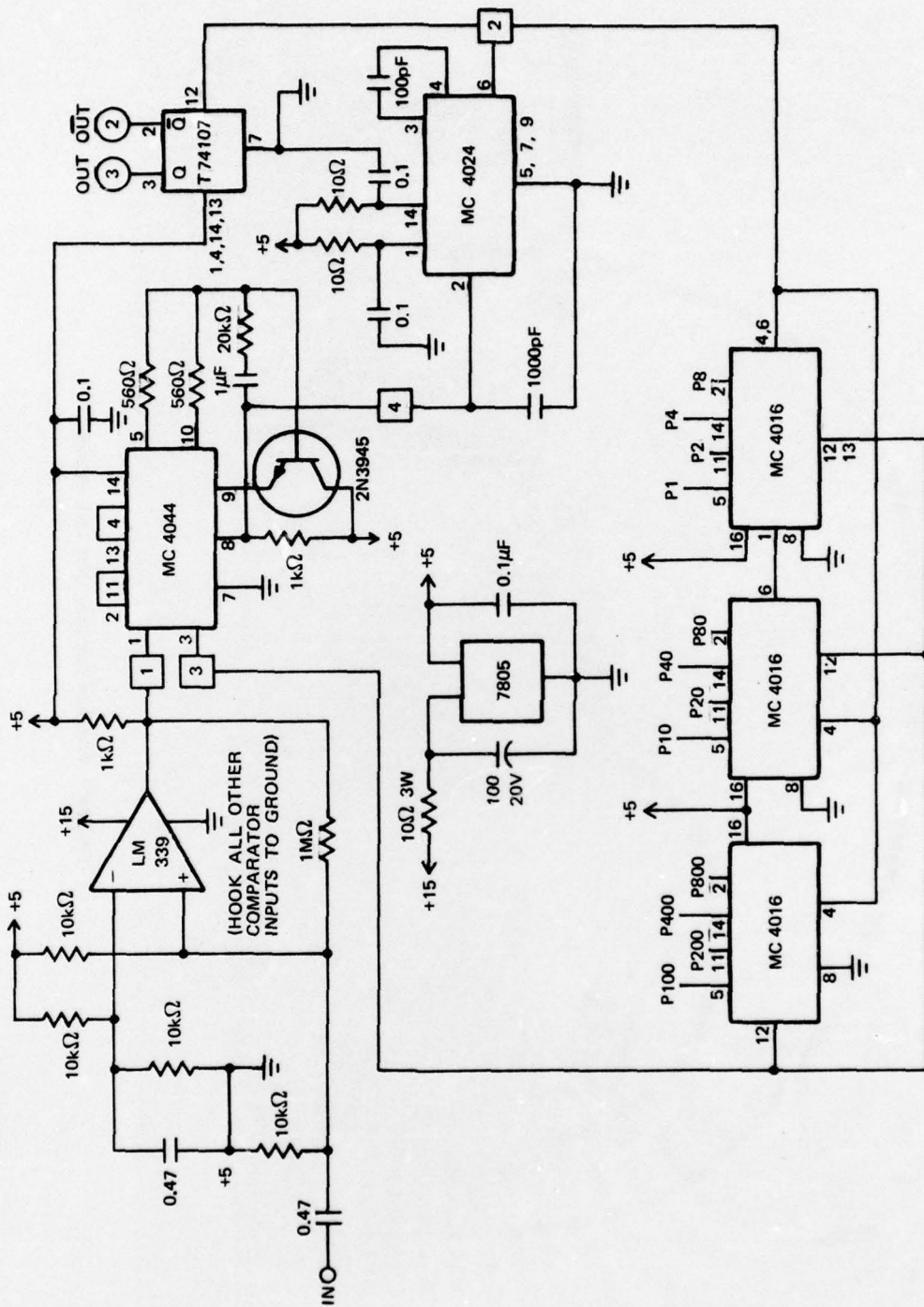

FIGURE 8. Master Subcarrier Generator.

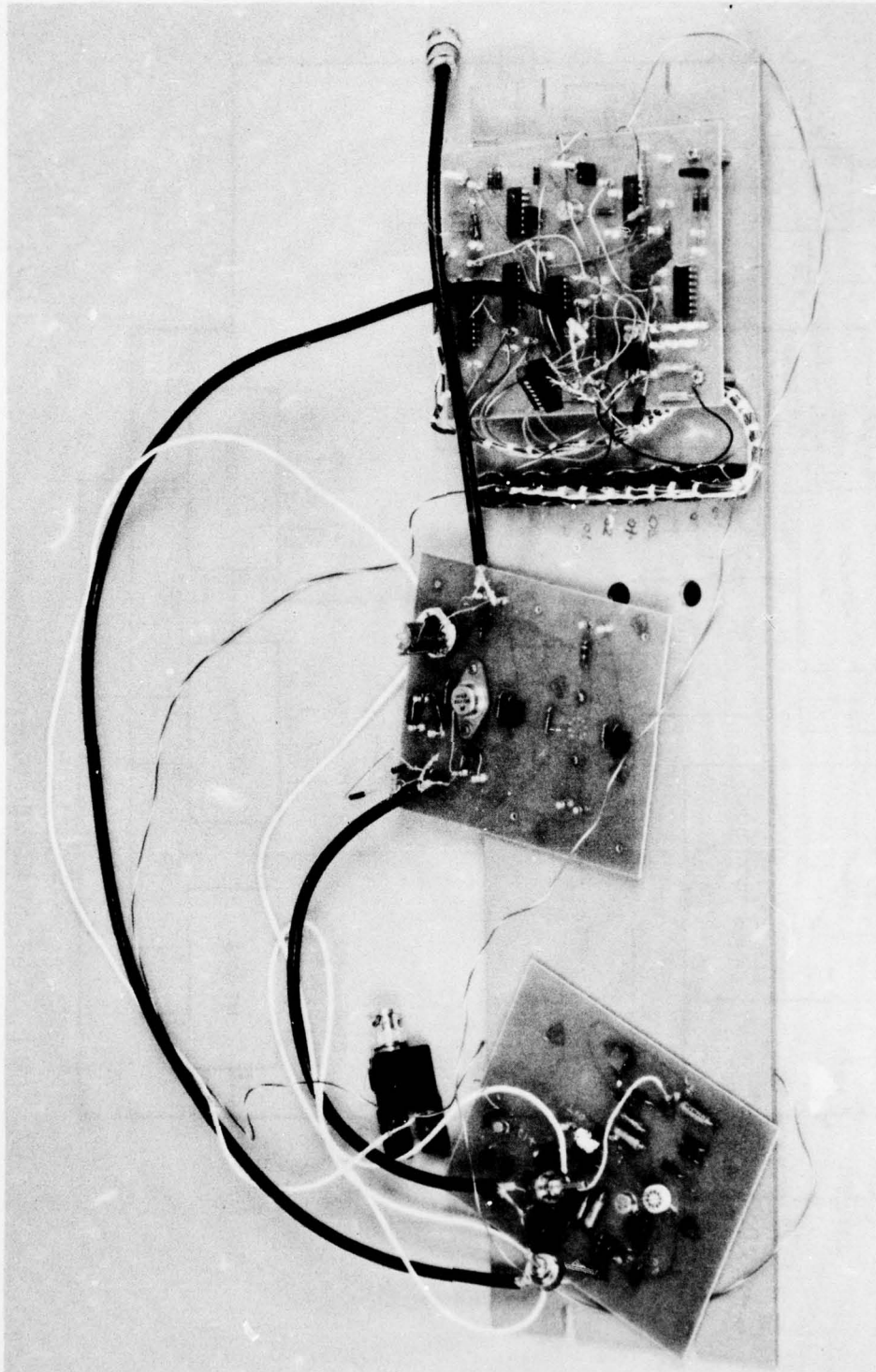

FIGURE 9. Prototype Test Unit. (Neg. LHL 193539)

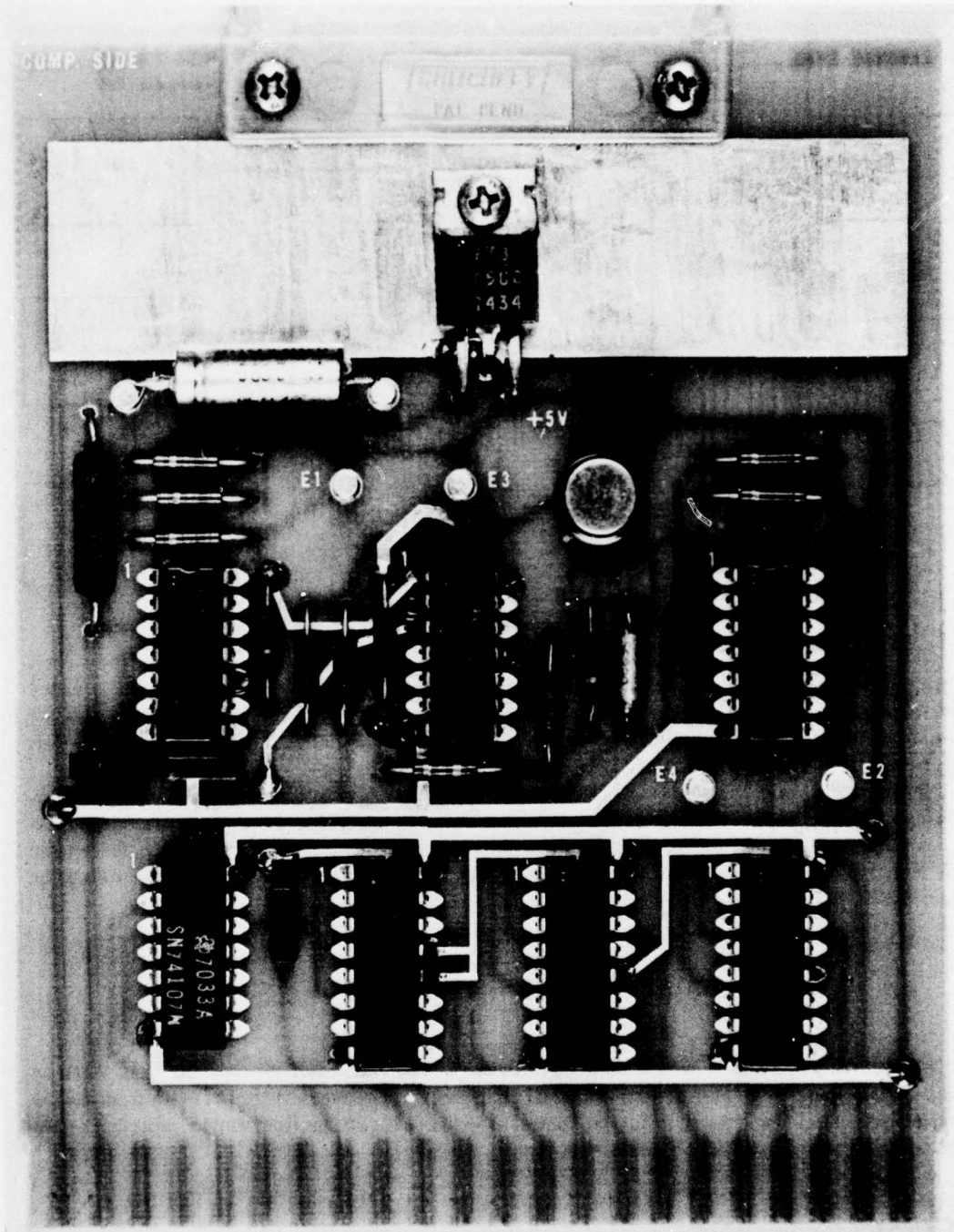

FIGURE 10. Subcarrier Generator Card. (Neg. LHL 193538)

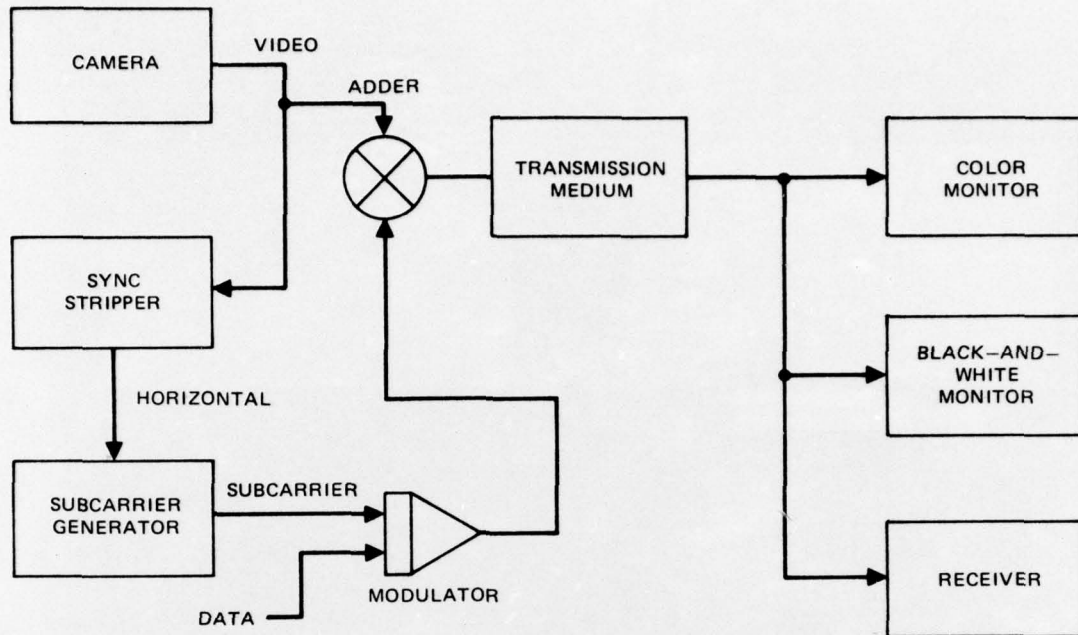

FIGURE 11. Demonstration Unit Test Setup.

increase in the 60-hertz noise. If the receiver were replaced by a synchronous detector, this slight frequency difference would be tracked, since the ratio of frequencies between the horizontal oscillator and the subcarrier remains constant. A disc recorder is driven at the same speed at all times, so no frequency shift occurs with discs used for slow motion, reverse, or stop motion.

Maximum picture degradation took place when a periodic data waveform was used; minimum degradation resulted from inputs that are more or less random in nature, such as would result from vibration data. Data consisting of voice caused an interference pattern that modulated at the syllable rate. Since voice data is intended for hearing only and thus requires a lower signal-to-noise ratio, subcarrier injection can be much lower, say 2% or less.

ADDITIONAL CONSIDERATIONS

The advantages of a new system must be sufficient to justify the costs of changing to it. When an existing system is already in place, and much of its equipment is obsolete, savings that result from the use of simpler transmitters and ground station equipment as well as labor savings from simpler procedures must be taken into account, as well as RF spectrum savings.

SPECTRAL

If the system under test feeds the receiving site through radio, rather than through cable, some part of the RF spectrum is occupied by those signals. Although the frequency spectrum is large, extending from DC to X-rays and beyond, practical considerations restrict the range over which a video signal can be

transmitted to frequencies between 50 and 10 000 megahertz; the data signal, being of narrower bandwidth, is restricted somewhat less. These frequencies of interest are already in use by many services, so the smaller the spectrum space occupied by any system, the more likely it is that it can be accommodated.

If a single RF link is used, data is normally transmitted on a subcarrier higher in frequency than the highest frequency present in the picture. With a normal NTSC picture, this puts the data subcarrier and its sidebands in the area above 4.2 megahertz. If the data signal is complex enough to generate significant sideband energy, the subcarrier must be moved a greater distance above 4.2 megahertz. The audio track in commercial TV, having a 15-kilohertz response, is at 4.5 megahertz. Typical subcarrier frequency for TV-telemetry combination signals ranges from 6 to 9 megahertz. Due to the complex nature of a TV signal, a direct expression of spectral bandwidth as a function of carrier deviation is not possible, but an FM signal with a 7.5-megahertz subcarrier would occupy a minimum of 15 megahertz of RF spectrum. With single-sideband AM transmission, a minimum of 7.5 megahertz would still be required. If two transmitters are used, one for the TV picture and one for the data, besides the obvious size, power, and cost increases, the picture bandwidth of 4.2 megahertz requires a minimum spectrum of 8.4 megahertz for FM, plus the spectrum occupied by the data transmitter. However, when the data is encoded within the picture spectrum, the spectrum of the data plus the video is no larger than the spectrum of the video signal alone.

NOISE

Signals of large bandwidths require more transmitter power than those of smaller bandwidths. This is a result of the thermal noise generated by space, which is seen by the receiving antenna even in the absence of a signal. The expression is

$$P = 4kTB$$

where P is power in watts, T is temperature in degrees Kelvin, B is bandwidth in hertz (cycles), and k is Boltzmann's constant, numerically equal to 1.38×10^{-23} J/K. (Using these figures and a temperature of 300 K, the noise power in a 6-megahertz channel, which is used for commercial TV in the United States, noise power is 9.936×10^{-14} watts, or approximately 100 femtowatts.) If the bandwidth is increased, the noise power at the receiver is increased. Doubling the receiving bandwidth requires doubling the transmitter power to maintain a constant carrier-to-noise ratio. For FM, doubling the data bandwidth while maintaining the same deviation decreases the signal-to-noise ratio if the power is the same in both cases, since deviation must be decreased to maintain the same RF bandwidth; doubling the deviation and the information bandwidth requires twice the power or degrades the overall signal-to-noise ratio by 3 decibels.⁵ Additionally, signal-to-noise ratio about any subcarrier decreases at a rate of 6 decibels per octave. Clearly, then, in FM transmission (which is usually employed for systems such as air-to-ground telemetry), a data subcarrier which increases the total bandwidth fed to the transmitter must be injected at a rather high level, thus decreasing the deviation due to the picture significantly. If the data is included within the picture passband, however, the requirement is eased: if, for example, a 2.25-megahertz subcarrier is used instead of a 4.5-megahertz subcarrier, injection can be 6 decibels lower for the same signal-to-noise ratio (neglecting noise effects due to the picture components). This is so whether or not preemphasis is used on the picture signal itself. Since the RF bandwidth is reduced and the picture comprises a larger portion of the total transmitted signal, system transmitter output power is reduced by 3 decibels or more—a significant amount in airborne systems, since telemetry transmitters are typically less than 20% efficient.

⁵ Elliot L. Gruenberg, *Handbook of Telemetry and Remote Control*. New York, McGraw-Hill, 1967. Pp. 6-11.

GROUND STATION OPERATIONS

Television signals, due to their basic nature (a spectrum from essentially DC to 4.2 megahertz and a required signal-to-noise ratio of about 40 decibels), are not easily recordable on normal ground station machinery. An IRIG Wideband Group II data recorder, for example, has a passband that extends from 400 hertz to 2 megahertz, even with the manufacturer's somewhat optimistic specifications, and this with a signal-to-noise ratio of 20 to 24 decibels. And these specifications apply to a tape speed of 120 in/s (762 mm/s) a speed at which a 9200-foot (2804-meter) reel of tape 14 inches (355 millimeters) in diameter has a recording time only slightly in excess of 15 minutes. FM recording can be used to improve the signal-to-noise ratio, but only at the expense of even greater recording speeds—at least double the 120-in/s speed. Only the most rudimentary, distorted, noisy, low bandwidth pictures can be recorded with normal data recorders. Clearly, to record pictures, a special-purpose videotape recorder is required. Such machines record TV pictures exceedingly well—usually a videotape cannot be distinguished from the original signal, unless some of the picture information is omitted to save tape, as described previously. When a data signal and a TV picture are sent, two recorders are normally used. If the data is sent as high frequency subcarriers above the video signal, detranslators or downconverters must be used to render the data in a frequency range compatible with ground station data recorders. If the data signal will fit the characteristics of an audio signal, it can be recorded on the sound track of the videotape. Most machines have one or two such tracks, but frequency response of these tracks is usually limited by the slow linear motion of the tape, usually less than 7 1/2 in/s (190 mm/s). If the data is sent by a second RF carrier, no detranslator is usually required, but a second recorder would normally be used. To make the data and video signals time-coherent for comparison later, a common time signal must be recorded on both, occupying one audio track on the videotape and at least one track on the data recorder. No convenient method is available to make the two tapes play back in time coherence, so normally the videotape would be played back and times of interest read; then the data tapes would be searched for those areas of interest. If a data-in-video system were used, however, the videotape and the data will always remain in sync, and if frame sync is maintained with still-framing (as is the case in disc systems), data can often still be made available in slow or stop-motion.

DATA FORMAT

Since the subcarriers generated by the system described herein are limited in frequency response to about 5 or 6 kilohertz, and limited somewhat on the low end by 60-hertz noise that results from videotaping, some data signals will need to be reformatted for best results. IRIG standards list several data formats compatible with such a channel; for example, IRIG proportional bandwidth channels 1 through 10. Obviously the baseband itself can be used for such signals as audio or vibration data. If a commutated system is used, the clock speed of the commutator should be selected to be one or a combination of the factors of 525, which are 5, 5, 3, and 7. In this fashion, data on succeeding frames tends to cancel the subcarrier out as seen by the viewer when data changes slowly.

When videotape is used as a storage medium, commutator channels that would reside in the vertical blanking interval could conceivably be distorted by head-to-head switching. This effect is minimized by having as few channels as possible (a channel with a duration of 3 lines, for example, would be more subject to such dropouts than channels 25 lines in length). A commutator synchronizing pulse is not necessary in a PAM or PCM system of this nature, because the decommutator frame reset can be coincident with, for example, the start of line 1 of the picture—at the end of the vertical blanking interval. Such a signal is available from the output of the sync generator that can be used at the output, or at certain points in the video monitor.

COST

None of the devices used in this system are particularly exotic in nature, as would be the detranslators used with the high-frequency subcarriers used in most systems, and demand on and the number of receivers and recorders is decreased. Synchronization of the data stream itself and of the data with the picture on playback is simplified since the camera sync generator is the principal source of both. Videotape recorders compare in price with lower-priced instrumentation recorders, are generally more portable, and use less tape. Since fewer spectral demands are made, the use of lesser bandwidth and fewer transmitters causes an immediate saving in parts and space, and the more simple frequency scheduling usually gives rise to a greater probability that spectrum space will be available on the schedule needed.

CONCLUSIONS

Use of the data-in-video technique is indicated in any system where data signals are collected along with a black-and-white or color TV display. Cost of such a system is generally lower than alternative solutions, and degradation of the picture can be minimal. The subcarriers can be videotaped along with the picture for later playback as long as the entire video signal is recorded; thus a playback of video and data is automatically synchronized. The technique can also be used in combination with other video data display methods with little or no interaction. Use of the technique also causes significant savings in bandwidth and transmitter power.

Appendix A

PHASE-LOCK OSCILLATORS

Many methods of multiplying some input frequency by an integer, for example, the use of a class C amplifier and the use of nonlinear devices to generate higher-order harmonics, limit the range of frequencies that can be handled, and do not lend themselves to digital techniques. Phase-lock oscillators, however, are digital in nature and take advantage of the simplicity with which digital circuits can divide frequencies; that is, they multiply by dividing.

The simplest phase-lock oscillator is the type used to generate a pulse train shifted 90 degrees from the input. It requires only an EXCLUSIVE-OR gate, used as a phase comparator, and a voltage-controlled oscillator (VCO). The VCO must be such that a rising voltage on its input causes an increase in output frequency, and it must be set so that its free-running frequency is close to the input frequency when its input is biased at half the power supply voltage. When it is connected as shown in Figure A-1, the output will be 90 degrees behind the input.

This circuit works because of a feedback path. If both signals entering the EXCLUSIVE-OR gate were in phase, the output of the EXCLUSIVE-OR would be a zero at all times, reducing the frequency and retarding the phase until the two were 90 degrees apart in phase on the input frequency, where the output of the RC filter would be half the power supply voltage. The opposite effect occurs when the inputs are exactly out of phase. Note also that if two 50% duty cycle signals are fed to an EXCLUSIVE-OR gate, the output of the gate is a 50% duty cycle signal of twice the frequency, so a frequency doubler is produced. If the line from the output of the VCO fed back to the phase comparator were broken and digital dividers inserted, the output of the VCO would have to rise to cause the comparator to null out. Thus the VCO is forced to produce a multiple of the input frequency. Since VCOs can be produced with multioctave ranges, such a multiplier can handle either a wide range of input frequencies or programmable dividers so that the multiplier can be programmed. While the system shown is restricted to dividers and inputs that produce 50% duty cycles, phase comparators can be designed to handle asymmetrical input signals and divider outputs, triggering on rising or falling edges of the two signals rather than on levels.

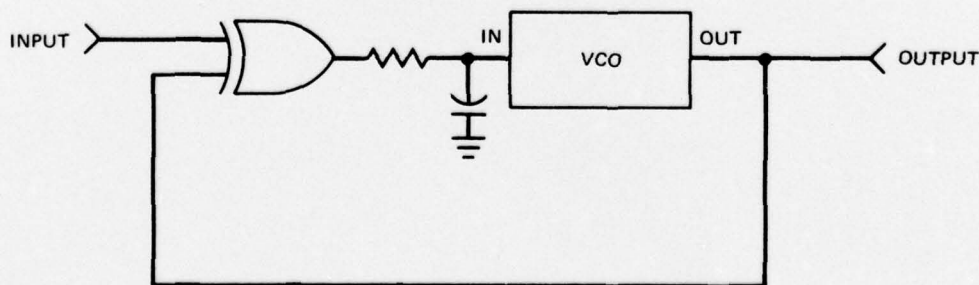

FIGURE A-1. Phase-Lock Oscillator Circuit.

INITIAL DISTRIBUTION

- 3 Naval Air Systems Command
 - AIR-6502 (1)
 - AIR-954 (2)
- 4 Naval Sea Systems Command
 - SEA-09G32 (2)
 - SEA-653 (1)
 - SEA-6543 (1)
- 1 Deputy Director Research & Engineering (J. A. Webster)
- 1 Atlantic Fleet Weapons Range, FPO New York (H. T. Herring)
- 3 Fleet Analysis Center, Naval Weapons Station, Seal Beach, Corona, CA
 - Code 851 (1)
 - Code 8513 (1)
 - Code 8522 (1)
- 4 Naval Air Test Center, Patuxent River (H. O. Norfolk, Jr.)
- 3 Naval Avionics Facility, Indianapolis, IN
 - Code 814
 - J. Brining (1)
 - K. Burgess (1)
 - Code 906 (1)
- 1 Naval Ordnance Missile Test Facility, White Sands Missile Range, NM
 - Code 502, W. W. Bohn
- 1 Naval Ship Missile Systems Engineering Station, Port Hueneme, CA
 - Code 4920, C. B. Tendick)
- 61 Pacific Missile Test Center, Point Mugu, CA
 - Code 1142, C. N. Gorevin (1)
 - Code 1262, D. H. Barthuli (1)
 - Code 3100, W. C. Christensen (1)
 - Code 3101, J. A. Means (1)
 - Code 3120, H. J. Crawford (1)
 - Code 3140, T. R. Carr (1)
 - Code 3142
 - R. W. Lytle (1)
 - C. G. Ashley (1)
 - J. Anderson (1)
 - Code 3143, M. A. Bondelid (1)
 - Code 3145, Z. H. Blankers (1)
 - Code 3150, J. R. Scott (1)
 - Code 3151, J. L. Weblemoe (1)
 - Code 3153, D. E. Ogden (1)
 - Code 3154
 - P. M. Newton (1)
 - C. E. Ohlen (1)
 - Code 3160, E. F. Mutz (1)
 - Code 3161, R. L. Nifong (1)
 - Code 3163, F. L. Allrad (1)
 - Code 3410, R. P. Carpenter (1)

Code 3411

R. J. Roanhaus (1)
R. H. Wymore (1)
J. T. Dickman (1)
W. T. Norton (1)

Code 3412, F. D. Leiblein (1)

Code 3440, W. F. Tolman (1)

Code 4250-1, M. F. Hayes (10)

Code 4251, D. S. Walker (1)

Code 4253-3, Technical Reports Library (2)

Code 4320, K. L. Berns (1)

Code 4321

D. R. Hust (1)
D. H. Rilling (1)
M. V. Wechsler (1)

Code 4322

E. R. Hill (1)
D. R. Knight (1)
D. A. King (1)

Code 4323

E. T. Kimball (1)
C. M. Kaloi (1)
E. L. Law (1)
L. B. Parolini (1)

Code 4330, R. P. Tegt (1)

Code 4331

M. A. Beckman (1)
T. P. Waddell (1)

Code 4340, J. D. Martin (1)

Code 4341

D. J. Dejong (1)
N. R. Drago (1)
G. J. Harbold (1)
E. R. Sandy (1)

AIR-630 (1)

AIR-6302 (1)

AIR-6302D (1)

4 Department of the Army, White Sands Missile Range, NM

STEWS-ID-IT

B. Chin (1)
J. D. Cates (1)

STEWS-ID-S

B. E. Norman (1)
E. Bejarno (1)

1 Army Missile Command, Redstone Arsenal, AL (AMSMI-RTA, Bldg 7855,

R. D. Bibb)

1 Army Electronic Proving Ground, Fort Huachuca, AZ (STEEP-MT-I,

W. T. Lyon)

2 Ballistic Missile Defense Advanced Technology Center, Huntsville, AL

BMDSC-RD, G. E. Wooden (1)

BMDSC-ROO, D. E. Parker (1)

- 1 Picatinny Arsenal, Dover, NJ (Telemetry Division, TSD, J. C. Greenfield)
- 1 Yuma Proving Ground, Yuma, AZ (STEYP-MDP, H. S. McElfresh)
- 3 Armament Development & Test Center, Eglin AFB, FL
 - ADTC-TSGGS, E. J. Poachell (1)
 - ADTC-TSGPG, B. L. Culberson (1)
 - Vitro Services, R. L. Manley (1)
- 1 Cambridge Research Laboratories, L. G. Hanscom Field, Bedford, MA (C. H. Reynolds)
- 1 Eastern Test Range, Patrick AFB, FL (AFETR-ENIB, P. Mann)
- 1 Federal Electric Corporation, Vandenberg AFB, CA (R. Streich)
- 1 Flight Test Center, Edwards AFB, CA (AFFTC-DOESD, J. Ramos)
- 1 Holloman Air Force Base, NM (6585 TG/TKIA, J. A. Haden)
- 2 Kirtland Air Force Base, NM
 - AFSWC-TED, CAPT P. J. Skelton (1)
 - 4900 TG/FTEI, J. C. Scott (1)
- 1 SAMTEC, Vandenberg AFB, CA
 - SAMTEC-ENIT, D. K. Manoa (1)
 - SAMTEC-ROOE, K. O. Schoeck (1)
- 3 Sandia Laboratories, Kirtland AFB East, Albuquerque, NM
 - Division 1251, R. S. Raynolds (1)
 - Division 9486, Box 5800, P. L. Walter (1)
 - Division 9421, Box 5800, H. O. Jeske (1)
- 1 Satellite Control Facility, Aerospace Corporation, Los Angeles, CA (C. Nakamura, Bldg 115/1341)
- 1 Satellite Control Facility, Sunnyvale, CA (Det 1, AFSCF-DOZR, G. V. Kreider)
- 12 Defense Documentation Center
 - 1 National Aeronautics and Space Administration, Washington, D.C. (Code MF, W. E. Miller, Jr.)
 - 1 National Bureau of Standards (Division 425.03, P. S. Lederer)
 - 1 National Bureau of Standards, Gaithersburg MD (GSA-FSS, J. J. Fiori)
 - 1 George C. Marshall Space Flight Center, Huntsville, AL (Code S&E-ASTR-1, W. Threlkeld)
 - 6 Aerospace Corporation, Washington, D.C. (Dr. W. R. Hedeman)
 - 2 Data Control Systems, Inc., Danbury, CT
 - M. Pizzuti (1)
 - D. A. Zeller (1)
 - 1 Data Control Systems, Inc., Danbury, CT (T. Castellano)
 - 2 EMR Telemetry, Sarasota, FL
 - S. Bass (1)
 - G. Tremain (1)
 - 2 Grumman Aerospace Corporation, Calverton, NY
 - R. S. McElhiney (1)
 - E. Charland (1)
 - 1 Harris Electronic Systems Division, Melbourne, FL (C. Curry)
 - 1 IED, San Diego, CA (C. Brewster)
 - 1 Jet Propulsion Laboratory, Pasadena, CA (R. Piereson)
 - 2 Martin-Marietta Corporation, Denver CO
 - C. M. Kortman (1)
 - S. Hurst (1)

