

AD-A033 363

CONSTRUCTION ENGINEERING RESEARCH LAB (ARMY) CHAMPAI--ETC F/G 13/13
INFORMATION FLOW FOR MILITARY CONSTRUCTION.(U)

OCT 76 J H JOHNSON

CERL-IR-ADS-2

UNCLASSIFIED

NL

1 of 2
ADA033363

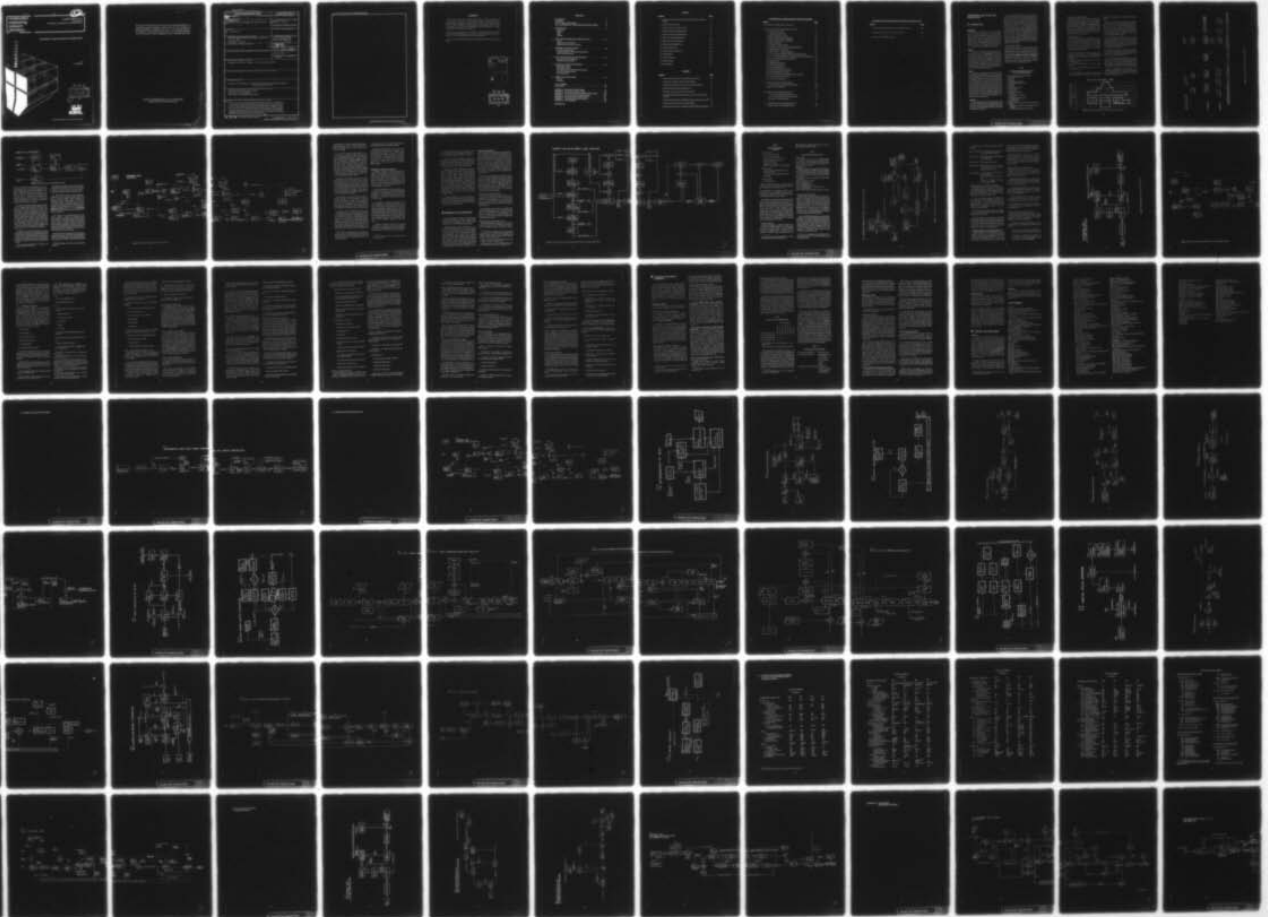

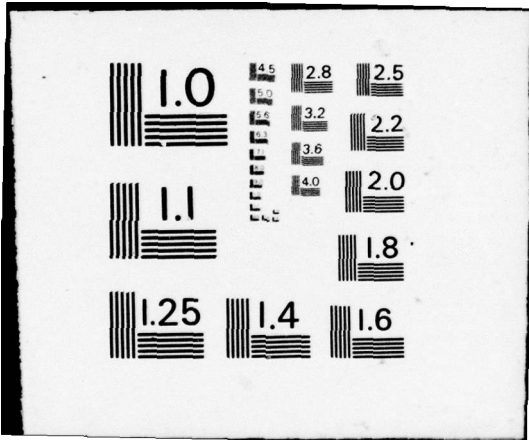

1
construction
engineering
research
laboratory

12
INTERIM REPORT ADS-2
October 1976
Coordination and Integration of AEADS Modules

INFORMATION FLOW FOR MILITARY CONSTRUCTION

ADA033363

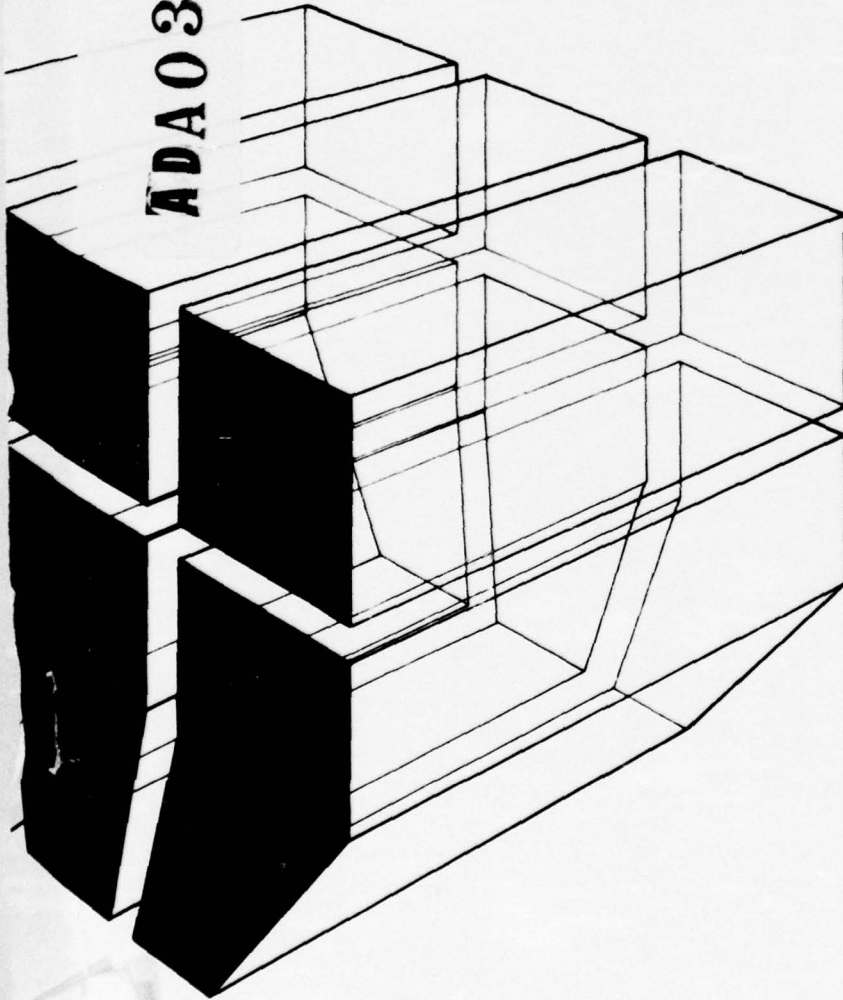

by
J. H. Johnson

DDC
RECEIVED
DEC 13 1976
RECEIVED

27

D



Approved for public release; distribution unlimited.

The contents of this report are not to be used for advertising, publication, or promotional purposes. Citation of trade names does not constitute an official indorsement or approval of the use of such commercial products. The findings of this report are not to be construed as an official Department of the Army position, unless so designated by other authorized documents.

**DESTROY THIS REPORT WHEN IT IS NO LONGER NEEDED
DO NOT RETURN IT TO THE ORIGINATOR**

UNCLASSIFIED

SECURITY CLASSIFICATION OF THIS PAGE (When Data Entered)

REPORT DOCUMENTATION PAGE		READ INSTRUCTIONS BEFORE COMPLETING FORM	
1. REPORT NUMBER CERL-IR-ADS-2	2. GOVT ACCESSION NO.	3. RECIPIENT'S CATALOG NUMBER	
4. TITLE (and Subtitle) INFORMATION FLOW FOR MILITARY CONSTRUCTION.		5. TYPE OF REPORT & PERIOD COVERED INTERIM rept.	
7. AUTHOR(s) J. H. Johnson		6. PERFORMING ORG. REPORT NUMBER	
9. PERFORMING ORGANIZATION NAME AND ADDRESS CONSTRUCTION ENGINEERING RESEARCH LABORATORY P.O. Box 4005 Champaign, IL 61820		8. CONTRACT OR GRANT NUMBER(s)	
11. CONTROLLING OFFICE NAME AND ADDRESS		10. PROGRAM ELEMENT, PROJECT, TASK AREA & WORK UNIT NUMBERS 4A762619AT41-01-020	
14. MONITORING AGENCY NAME & ADDRESS (if different from Controlling Office)		12. REPORT DATE October 1976	
		13. NUMBER OF PAGES 127	
		15. SECURITY CLASS. (of this report) Unclassified	
		15a. DECLASSIFICATION/DOWNGRADING SCHEDULE	
16. DISTRIBUTION STATEMENT (of this Report) Approved for public release; distribution unlimited.			
17. DISTRIBUTION STATEMENT (of the abstract entered in Block 20, if different from Report)			
18. SUPPLEMENTARY NOTES Copies are obtainable from National Technical Information Service Springfield, VA 22151			
19. KEY WORDS (Continue on reverse side if necessary and identify by block number) Army Military Construction (MCA) information flow networks MCA project development procedures			
20. ABSTRACT (Continue on reverse side if necessary and identify by block number) This report presents information flow networks which correlate the operations and information flow supporting Army Military Construction (MCA) projects within the Corps of Engineers during the planning and programming phase. The diagrams are developed at three levels of functional inclusiveness to provide pertinent, ordered, and logical information flow to each reviewer of the MCA process. Identification of representative fiscal year (FY) 76 MCA procedures to the level necessary for a fundamental understanding necessitated the 30 information flow networks presented.			

SECURITY CLASSIFICATION OF THIS PAGE(When Data Entered)

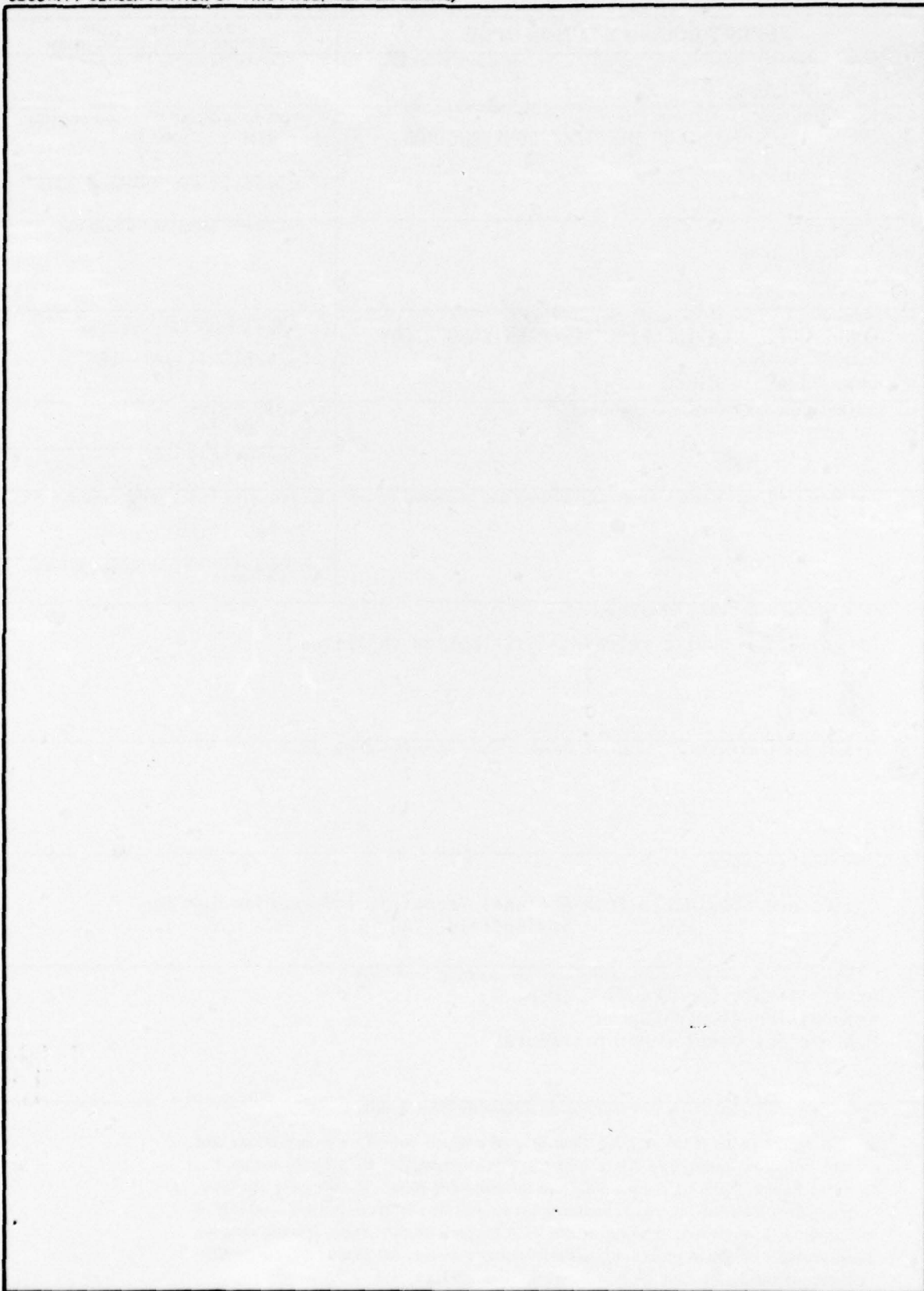

SECURITY CLASSIFICATION OF THIS PAGE(When Data Entered)

CONTENTS

DD FORM 1473	1
FOREWORD	3
LIST OF TABLES AND FIGURES	5
LIST OF INFORMATION FLOW NETWORKS AND APPLICATIONS	6
1 INTRODUCTION	9
Background	
Purpose	
Scope	
Approach	
2 IDENTIFYING INFORMATION FLOW WITHIN THE CE	13
General	
Applications to Key Procedures	
Applications to Local District Functions	
3 ASSESSMENT OF CE PROCEDURES	18
Influences on MCA Projects	
Procedural Categories in MCA Project Development	
Other Procedural Influences	
4 DEVELOPED INFORMATION FLOW NETWORKS	27
Structural Pattern of the Networks	
Functional Content of Blocks	
5 REVIEW OF DEVELOPED CE NETWORKS	34
MCA Projects, CONUS	
MCA Projects, Foreign	
Army Reserve Center (ARC) Construction Projects	
Air Force Construction Projects	
NASA Construction	
6 SUMMARY AND CONCLUSIONS	37
Summary	
Conclusions	
LIST OF SYMBOLS	37
REFERENCES	40
APPENDIX A: MCA CONUS Project Procedures	41
APPENDIX B: MCA Project Procedures, Foreign	97
APPENDIX C: Army Reserve Center Construction Project Procedures	103
APPENDIX D: Air Force Construction Project Procedures	107
APPENDIX E: NASA Construction Project Procedures	111
APPENDIX F: Code Designations for OCE Directives	115
APPENDIX G: Forms and Reports	116
DISTRIBUTION	

TABLES

Number		Page
1	Categories of Documentation and Data Used in MCA Programming and Planning	9
2	Master Plan Documentation	21
3	Program and Project Information Forms	21
4	FH New Construction Supporting Data	35
5	National Evaluation Team Membership	35
G1	Department of Defense (DD) Forms	116
G2	Department of Army (DA) Forms	118
G3	Standard and Engineering Forms	119
G4	Savannah District Forms	122
G5	Sacramento District MCA Forms	124
G6	Annual Reports	125
G7	Semiannual Reports	126
G8	Quarterly Reports	127
G9	Monthly Reports	127

FIGURES

Number		Page
1	Approval and Generation Levels of MCA Project Information	10
2	Development of Definitive Outputs for MCA Projects	11
3	Example MCA Information Flow and Functional Block Diagram	12
4	Installation Master Plan Development Process	14
5	MCA Project Information Flow Network, Top Flow	15
6	Installation Master Plan Development, Basic Function Information Flow Network	19
7	Army Real Property Inventory (RPI) System Before Implementation of IFS	22
8	Family Housing New Construction, Turnkey Project	24
9	Performance Area Network for MCA Projects With Reimbursable Funding	25

INFORMATION FLOW NETWORKS AND APPLICATIONS

Section	Page
A-1 Performance Areas MCA, Minor Construction	45
A-2 Performance Areas MC Projects, Major Construction	49
1.0 Determination of Need	51
2.0 Planning and Programming	52
3.0 District Preliminary Activities	53
4.0 Major Command Review (TRADOC)	54
4.0 Major Command Review (FORSCOM)	55
5.0 Proposal Submittal	56
6.0 OCE Project Technical Review	57
7.0 OCE Project Evaluation and Program Representation	59
8.0 Budget Preparation and Review	61
9.0 District Project – Support Organization	62
9.1.1 to 9.4.7 District Organization Support and AE Preselection	63
9.4.8 to 9.4.13 District Organization, AE Selection and Contract Negotiation	65
9.4.14 to 9.7.4 AE Contracting and Design NTP	67
10.0 Concept Design	69
11.0 OSD/DA Policy Approval	70
12.0 Concept Design Review	71
13.0 District Prefinal Activities	72
15.0 and 16.0 Final Design and FD Review	73
18.0 District MC Project Contracting	75
18.1 and 18.2 MCA Bid Processing and Precontract Activities	77
18.6 to 18.8 Construction Contracting	79
20.1 AE Contract Completion	81
A-3 Performance Practices of Selected Districts	82
9.4 Award of AE Contract (Sacramento District)	88
District Cost Control System	89
A-4 Performance Area FH New Construction	92
1.0 to 8.3 Family Housing New Construction	93
9.1 to 9.7 FH Turnkey Construction Contracting	94
Performance Area FH Improvement	95
B EUD Performance Areas (Germany) MC Projects	99
EUD Performance Areas (Italy) MC Projects	101

INFORMATION FLOW NETWORKS AND APPLICATIONS (Cont'd)

Section	Page
C Performance Areas Army Reserve Center (ARC) Construction	105
D Performance Areas Air Force Construction Projects	109
E Basic Functions NASA Construction	113

INFORMATION FLOW FOR MILITARY CONSTRUCTION

1 INTRODUCTION

Background

Information flow within the Corps of Engineers (CE) is reviewed in this report as it relates to Army Military Construction (MCA) project development. The report answers the need for a generalized procedural summary of CE construction planning activities and was derived from an MCA procedures study at the U.S. Army Construction Engineering Research Laboratory (CERL). This report is a delineation of actual CE practices; it is **not** a source of regulatory requirements.

Purpose

The purpose of this report is to provide information flow characteristics of **representative** MCA project development procedures from proposal to award of the construction contract. The information flow networks of this report (compiled in Appendices A through E) were developed by correlating information flow with MCA functional operations, and are intended to provide reviewers of the MCA process with a source of CE procedural data sufficient for developing accurate concepts and reaching valid conclusions.

Scope

All intra-agency information flow directly resulting from planned or performed military construction within the CE is delineated in this report from development of the planning document to award of the construction contract. Representative procedures for fiscal year (FY) 76 are described by information flow networks for each major category of CE military construction. These networks present specific levels of functional detail for the convenience of differing reader review levels and identify principal functions, approval/action activities, and data transfer means or mechanisms appropriate to each level. The report also identifies internal data transmission events or systems when substantive to the greater information flow picture.

Approach

CE operating procedures were ascertained by surveys of the field operations and controlling regulations. The survey data were evaluated and organized for presentation, and a presentation method developed using simple information flow networks.

The information flow networks were developed at three correlated levels of functional inclusiveness. The first level is a "Top Flow" of interrelated managerial performance areas which provides an overall view of MCA project support operations. The second level is basic-function oriented, with each function related by position and number to an associated performance area in the top flow. The second or middle flow permits a nominal understanding of MCA working operations. The third level is concerned with detailed functions and events which again are related by position and number to both top and middle flows. The bottom flow provides the detailed relationships necessary to define and orient formal and informal data transmission, plans and status reporting, and other types of legal and informal communications.

Categories of Information

Identifying the types of information inherent in MCA information flow systems within the CE was fundamental to the network development process. MCA information flow systems facilitate and promote intended **project development** and **effective management control** by providing the necessary documentation, performance/status reports, and special or general-support study reports. These data may be further differentiated by the use-categories in Table I.

Table I

Categories of Documentation and Data Used in MCA Programming and Planning

1. Project definition; limits or criteria documents
2. Action-implementation forms
 - a. Directives
 - b. Approvals
 - c. Verifications/certifications
3. Contracting/operations support data
 - a. Materials
 - b. Personnel
4. Project reporting documents
 - a. Progress reports
 - b. Status reports
5. Summary reports (periodic)
 - a. Base status
 - b. Projects initiation and progress
 - c. Fiscal status
 - d. Developmental and design status
 - e. Contracting status
 - f. Disclosure status
6. Management-effectiveness improvement and feedback documentation
 - a. Engineering Improvement Recommendations System (EIRS) data
 - b. Command management-improvement reports

Sources of Report Information

Information flow may be required by regulation, management directive, procedural necessity, or general practice. This report utilized the Armed Services Procurement Regulations (ASPR), Army Regulations (AR), Engineering Regulations (ER) or Pamphlets (EP), and CE policy as regulatory authority. Interviews with District and Division personnel established local procedures and practices. The Office of the Chief of Engineers (OCE) also provided informal input.

Presentation Methods

The format used to present the MCA information flow data was developed based on the material's descriptive requirements and intended use. The desired association between specific activities or functions and categories of generated data could not be clearly presented on a critical-path method chart or a standard computer program flow diagram.

A network approach was chosen to emphasize the significance and orientation of the identified MCA information flow. Three types of flow networks were considered:

1. Approval and/or generation level vs. a time or phase base (Figure 1).
2. Input/basic-function/output vs. project phase (Figure 2).
3. Functions at compatible levels connected by data flow arrows (Figure 3).

The first type (Figure 1) defines the principal areas of basic responsibility in the initiation, control, devel-

opment, and contracting of a military construction project.

Figure 2 illustrates the second approach, using District specifications and bid-package production for an MCA project over the five development phases — budgetary, predesign, design, contract development, and contracting. (The development phase is used since use of a time-base with this diagram involves either complicating mechanisms to represent variance or the use of oversimplifying assumptions.)

The selected approach (Figure 3) depicts the MCA project development at the "performance area" level and includes summary, formal project, and unofficial information flow. (As in Figure 2, a time base is not included.) This method allows easy identification of all general information flow features.

The function rectangles are provided according to their probable sequential occurrence at three levels of detail in three corresponding flows: performance area, basic function, and detailed function.

The information flow is represented by appropriately labeled arrows which connect each function to another function box, to a decision point (diamond), or to a hold point (bisected circle). The arrows may be solid (required), dashed (informal), or dotted (representation).

Readers knowledgeable in CE procedures and the presentation method used here may go directly to Chapter 4 and Appendix A for an abbreviated presentation of the MCA development process.

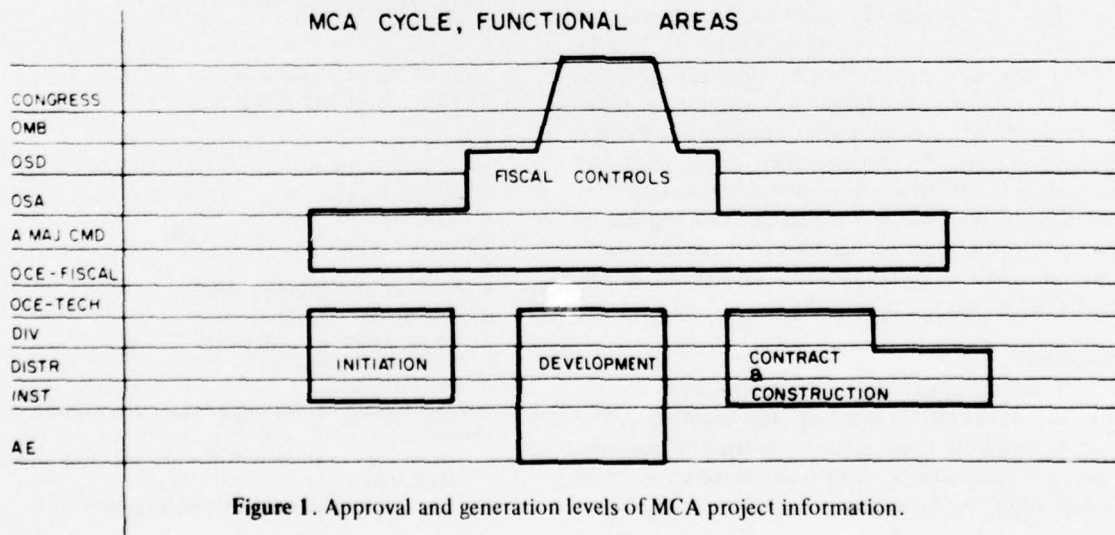

Figure 1. Approval and generation levels of MCA project information.

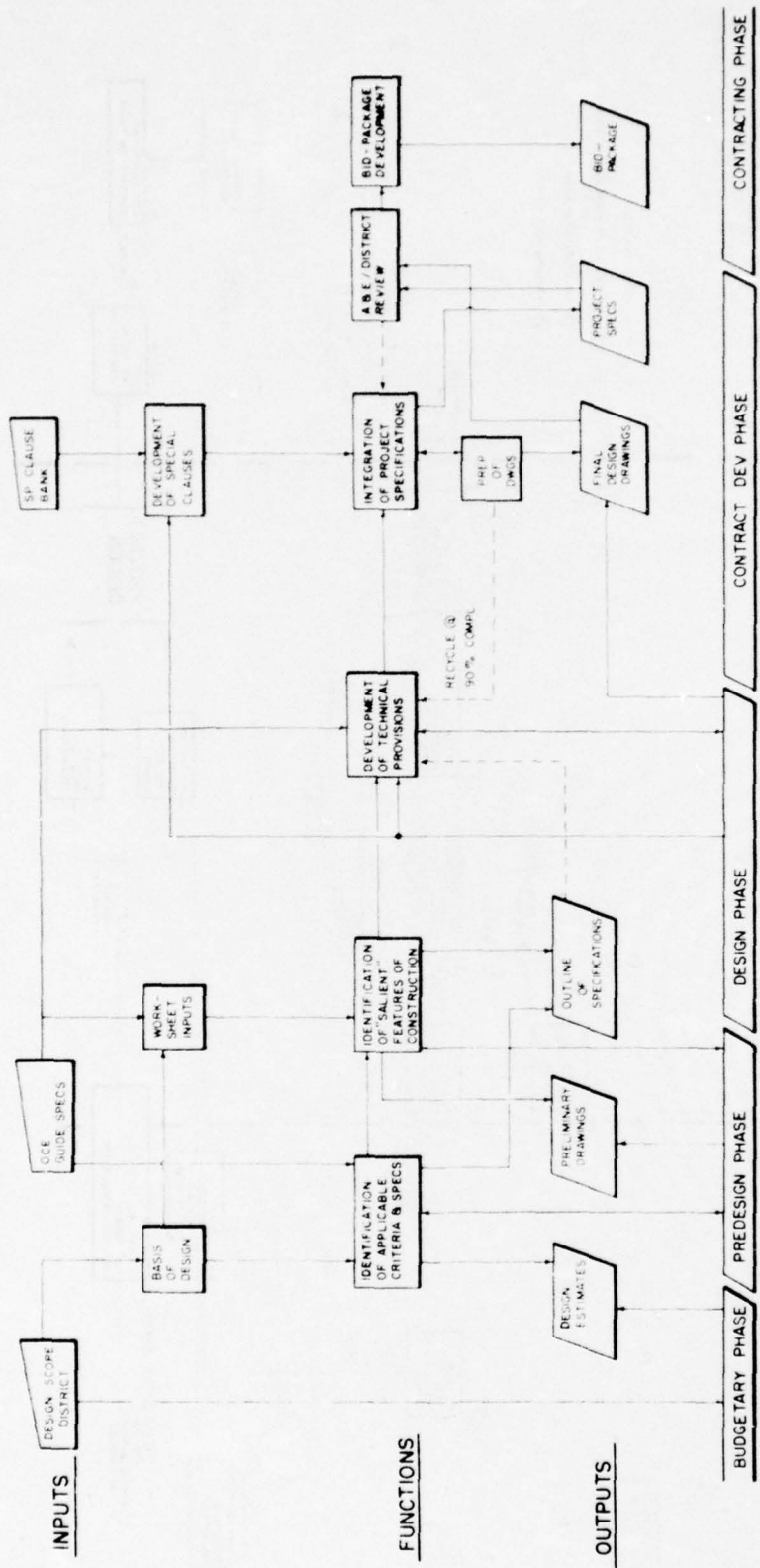

Figure 2. Development of definitive outputs for MCA projects.

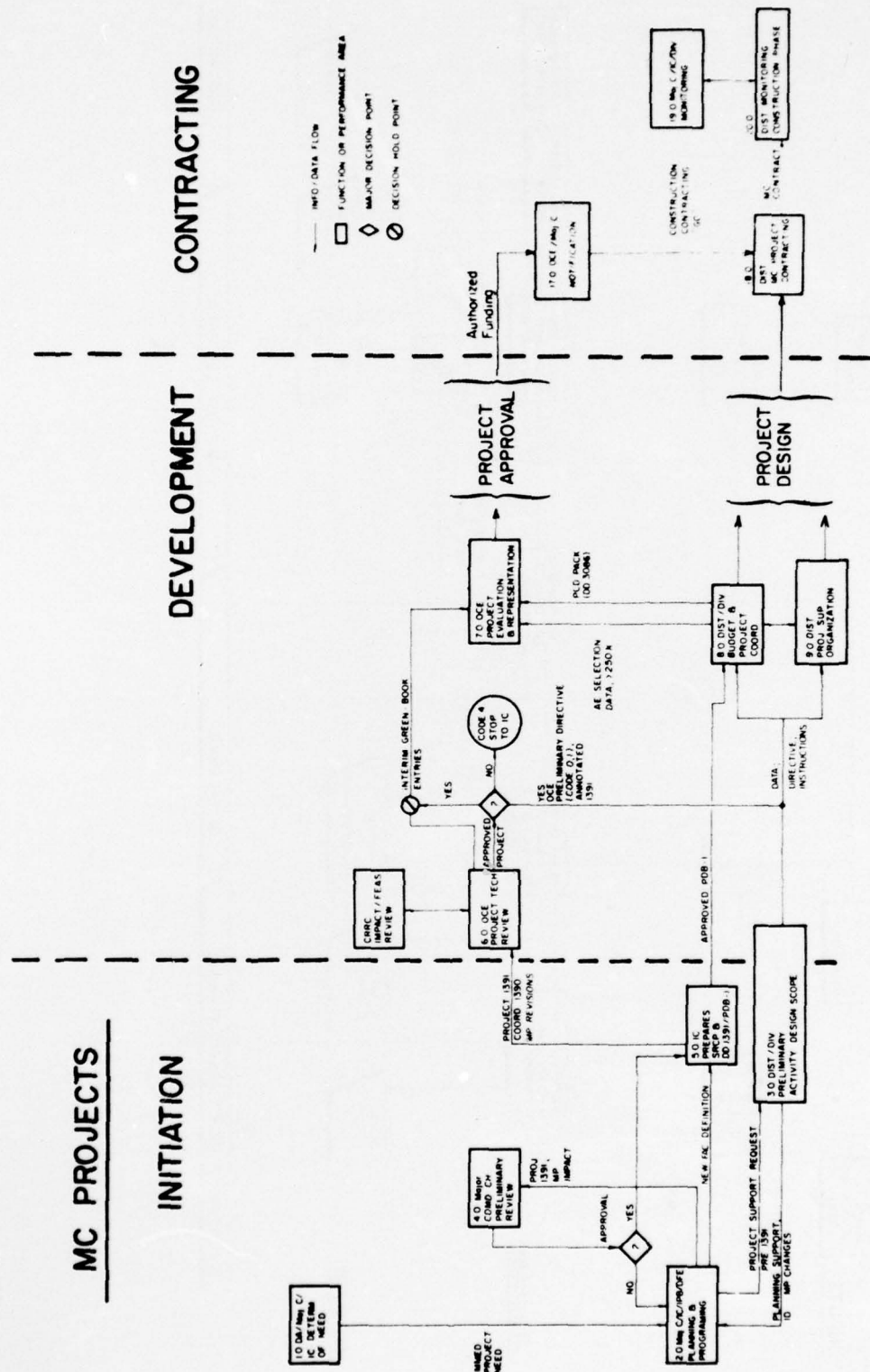

Figure 3. Example MCA information flow and functional block diagram.

2 IDENTIFYING INFORMATION FLOW WITHIN THE CE

General

The identification and evaluation of information flow in a complex development process can be facilitated by the use of representation networks. In this report, interpretation of CE procedures by functional flow diagrams permits delineation of information flow within the multiple interactions of MCA procedures.

Information flow includes communications (the transmission, receipt, and interpretation of intelligence), any movement of data records; and documentation activities. The definition of true **communications** does not include uninterpreted data transmission or data storage for contingencies. Information flow includes all movement of data or ideas; however, beneficial information flow is the transmission of information which is **received and used**. Military construction information flow, which is generated in support of determining facility needs and developing such needs into formal project proposals and installation programs, details the evaluation and confirmation of the program, the assessment of its validity for budgeting purposes, and the eventual processing and development of the program through design into the construction phase.

Applications to Key Procedures

The information flow network method of this report is a generalization; specific cases of MCA project development are not represented. The network presentation allows **master plan** and **MCA project** development procedures to be identified by block functions that are sequentially oriented. The **block functions** and the **data flow lines** connecting them permit definition of the data generated and identification of the knowledge transmitted between the functions. The value, and hence, the level of support provided information flow depends on the criticality, degree of activity, and occurrence of the functions which transmit or receive these data.

Application of these concepts to information flow diagrams for the overall MCA procedure is demonstrated by the following survey of program and project development activities.

Master Planning

The key role of the Master Plan (MP) in CE proce-

dures (AR 210-20¹) should be reviewed in order for the reader to properly assess MCA project development. Annually, the construction selection process for the next Short-Range Construction Program (SRCP) is normally derived from the Intermediate-Range Construction Program (IRCP), which has evolved (with good planning) from the Long Range Construction Program (LRCP). This procedure is the yearly adjustment for MCA progress to the MP and derivative installation construction plans. It is also a convenient time for incorporating necessary or desired revisions.

The MP is initially developed in three phases (Figure 4) and consists of three corresponding parts.

Phase 1 identifies existing facilities or real estate by documentation in a Basic Information Map (BIM), an Analysis of Existing Facilities, and a Building Information Schedule (BIS). These documents locate and identify existing facilities; the BIS is essentially a print-out listing buildings ranging from shelters to office buildings. If there is an emergency allocation, a Preliminary Land Use document may also be included in Phase 1.

Phase 2 includes a tab listing of Existing and Required Facilities, an Analytical Report of proposed or planned projects, and a Regional Plan. The first two documents define the need and the facility which meets this need. The Regional Plan includes a site plan and a reservation plan (a detail-type plan of the proposed project).

Phase 3 relates to factors such as environmental protection, use of utilities, utility loads, and development of roads in support of each planned project.

The MP is the responsibility of the Installation Commander (IC) who is supported by the Facilities Engineer (FE). The FE may provide funds to the District Engineer (DE) to reimburse the District in its installation-support efforts.

Programming and Design Process

Programming and design brings a major MCA project from the proposal or MP scheduling stage to construction contracting (Figure 5). Inclusion of a project in the proposed SRCP by the IC begins the programming

¹Master Planning for Permanent Army Installations, AR 210-20 (Department of the Army, 1 January 1973). The revision to AR 210-20 issued 15 March 1976 was not considered in this study.

MASTER PLAN DEVELOPMENT

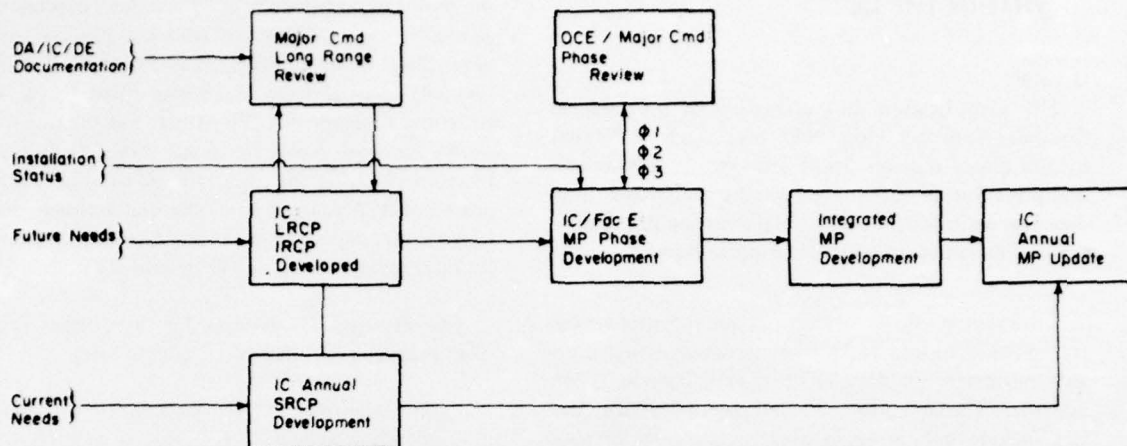

Figure 4. Installation master plan development process.

function. Forwarding a completed DD Form 1391 to the Department of the Army (OCE) and an approved Project Development Brochure-Part I (PDB-1) to the District implies Major Command endorsement of the project as worthy of submission to the Department of the Army staff for consideration for inclusion in the budget year program. (The "budget year" is the fiscal year preceding the fiscal year in which the associated budget will be submitted to Congress.)

Formal proposed facility requirements are developed by the Installation Planning Board (IPB) and documented on the Military Construction Project Data Sheet (DD Form 1391). The IC submits an initial 1391 to the Major Command (MACOM) for evaluation and approval for inclusion in the SRCP.* Upon acceptance and any resulting modifications, the IC binds applicable documents (the 1391, a budget attachment, and several site plans) or specially prepared data (per TM 5-800-3²) and sufficient descriptive narrative to form the PDB-1. The PDB-1 is sent to the District Engineer, and the DD Forms 1390 (MC Program data) and 1391 plus budget attachment are forwarded to the MACOM.

*The SRCP is the new fiscal year (budget year +1) program being developed for submission to the Congress. Due to recent procedural changes, the development of the SRCP extends over a period of about 19 months measured from the closing date for submittal of detailed DD Forms 1391 to OCE until the final program is submitted to Congress. Hence the preparation periods for two successive SRCPs overlap for a period of about 7 months.

²Project Development Brochures-Part I, TM 5-800-3 (Department of the Army, 15 May 1974).

MACOM-approved SRCP data from each installation are reviewed and evaluated by OCE. OCE may direct the District to perform preliminary project studies or concept design while the project is still under review.

The OCE technical reviews are often conducted in parallel with that of the Construction Requirements Review Committee (CRRC), which investigates the applicability, impact, and feasibility of the project at the DA staff level. If CRRC gives the project a low rating, OCE drops the project and no directive is issued; if CRRC recommends the project, OCE issues either a **preliminary directive** (Code 1*); or a **concept-design directive** (Code 2) together with an annotated DD Form 1391 to the District.

After receipt of the implementing directive, the District organizes to support the program. District design support is planned by the DE, and the decision for an in-house or Architect-Engineer (AE)-prepared design is made. If AE support is desired, AE selection and design contract negotiation activities are performed subject to certain funding-level/AE-approval regulations. Considerable variation is allowed in the AE contract and the degree of AE project support.

During this period, if so directed by OCE, the District prepares a Preconcept Control Data Package (PCDP) for detailed OCE budget reviews and future Congressional review reference. The PCDP consists of budget sketches,

*The code designations for OCE directives are presented in Appendix F.

an Engineering Form 3086 ("Current Working Estimate-Budget Planning"), and any clarifying supplementary data. OCE evaluates the cost aspects of the project based on the PCDP.

If the project is approved, OCE includes it in a "Green Book" consisting of the DD Forms 1390 and 1391 for DA-approved planning. The "Green Book" is forwarded for Office of the Secretary of Defense (OSD)/Office of Management and Budget (OMB) review, and the project is checked to insure that it is in the Five-Year Defense Plan (FYDP).^{*} The "Green Book" is adjusted to reflect the approved OSD program. It is then sent to Congress where OSD, with OCE support, seeks approval of Congressional committees. The PCDP is used by the OCE representative at Congressional committee meetings to provide more detailed information on questioned programs or projects.

Implementation of design is initiated by an appropriate directive from OCE. This usually precedes construction approval by Congress; the design of small or predesigned projects often proceeds to completion during the approval deliberations by Congress, with project development being carried up to the construction-contract stage. However, no project can be awarded until after the funds become available through authorization and appropriation by Congress.

A design directive may specify partial development (Concept Design) or provide authority to continue through Final Design, according to the management needs of the project. Of course, DA may determine that a project is inappropriate and stop the operation **at any time**. This potential for project termination must be remembered to properly interpret the report flows.

Completion of the Concept Design (CD), which represents approximately 25 percent of the total design, is accomplished by the District's Design Branch or by a contracted AE. An extensive user/installation/District review of the CD is required, and Division-approved changes are incorporated. The Final Design (FD) is then generated with District review. The AE incorporates any corrections and/or revisions, and prepares the final drawings and specifications. The design phase is completed with review and sign-off by the next higher level

^{*}The FYDP is an official publication of OSD which summarizes the approved (construction) plans and programs of DOD components. The FYDP contains data from prior fiscal years and for the current fiscal year, the budget year, and 4 subsequent fiscal years.

— the District Engineer for AE-prepared designs and the Division Engineer for District-prepared designs.

The District then proceeds to the construction-contracting phase, which depends on completion of the Congressional appropriation. From the AE-supplied FD drawings and technical provisions, the District formulates contract content and produces a bid package for distribution to interested bidders (previously notified by the "Advance Notice" sent to listed bidders and/or by the formal advertisement in *Commerce Business Daily*).

Applications to Local District Functions

Correlations between the District MCA mission, District branch assignments, and the generalized procedures of the information flow networks are not always obvious. Typical branch functions are provided below with specific branch assignments for four Districts outlined in section A-3 of Appendix A. The functions now provided were suggested by OCE for selected branches of the Engineering Division in the District guidelines of ER 10-1-3.³

1. Design. Responsible for structural design, architecture, electrical engineering, mechanical engineering, miscellaneous civil engineering, and other technical disciplines not specifically assigned to another branch. Responsible for preparation of plans and specifications for construction.

2. Foundations and Materials. Responsible for all matters pertaining to surface and subsurface explorations, foundations and embankment design, site investigations, underseepage, slope protection, construction materials development, airfield and vehicular pavement structural design, division laboratory and other functions pertaining to geology and soil mechanics engineering. In those divisions having separate Geology and Foundations and Materials branches, the responsibilities listed above would be divided by disciplines as the names imply.

3. Military. Coordinates planning and technical requirements of using services; monitors and insures performance of all Engineering Division responsibilities for prosecution of the military construction program.

³*Divisions and Districts*, ER 10-1-3 (Department of the Army, 1 May 1968).

4. *Survey.* Responsible for matters pertaining to and the accomplishment of all topographical and construction surveying and mapping activities in the District.

5. *Service.* Provides administrative support and drafting support (optional) to the Engineering Division including typing and stenographic, central files, office supplies, travel orders, reproduction, personnel requests, time and attendance reports, and similar functions.

6. *Planning and Reports.* Responsible for planning studies, including but not limited to preauthorization studies, feasibility studies under special continuing authority programs, Phase I Advance Engineering and Design, and other studies involving the formulation, impact assessment, and evaluation of water resources plans. Responsible for preparation, coordination, and processing of planning reports to higher authorities, as well as coordination of reports with other Federal agencies and non-Federal interests. Responsible for providing input for the General Investigations budgetary submission, as well as portions of the Construction General budgetary submission related to the above planning activities.

7. *Program Development.* In those Districts not having a Program Development Office at staff level, is responsible for all functions pertaining to the budgetary cycle, preparation of PB forms, testifying officer data, and similar programming material.

3 ASSESSMENT OF CE PROCEDURES

Project-identifying characteristics, the development of CE functional interfaces, and the evolution of legal and operational requirements have influenced the development of current MCA planning procedures.

Understanding MCA project development at the generalized procedure level requires some knowledge of the characteristic influences and limitations applied to these procedures. The interrelationships between DA management control systems and the several categories of MCA project development are identified diagrammatically in this section. An understanding of the correlation between information flow and the management and control of MCA project planning will facilitate understanding of the development of the programming networks explained in Chapters 4 and 5.

Influences on MCA Projects

The controls placed on installation planning influence MCA development procedures. The mechanisms used in the regulation and control of installation development and planning interface with and often impact MCA projects and their implementation approach. Effective monitoring of the current status, strength projections, life cycles, and MP revisions of an installation is an important management objective. Certainly, any evaluation of the timeliness, feasibility, and approach to be used in introducing new facility proposals considers the mechanics of such information and control systems.

The Corps-wide Standard Finance and Accounting System now under development will interface with and provide information to District management control systems.* the OCE Design Progress Reporting (PR) System (ER 415-345-43⁴), the Resource-Allocation/Project-Management System (RA/PMS), and the Integrated Facilities System (IFS). The IFS describes user requirements and is an input to the functional criteria portion of the Master Plan.

Real Estate Status (ER 405-345-100⁵)

A corollary of facility programming is site selection, acquisition, and preparation. The installation can perform this function initially or at some convenient time prior to final design. The installation may request the District/Division to assist in the process if analytical difficulties arise.

Land acquisition can be initiated by a Real Estate Directive (designating the land to be acquired and the amount of funds available for the acquisition). This directive is issued by the agency/department head when authorized by OCE per authority delegated by the Secretary of the Army.

Master Plan Revision Status (AR 210-20)

The MP is developed as defined in AR 210-20 and outlined in Chapter 2. Table 2 describes the content of the three development phases, and Figure 6 illustrates

*For information on implementing a District management control system see U.R. Poskus, *Executive Summary for the Automated Military Construction Progress Reporting System (AMPRS)*, Technical Report P-50 (Construction Engineering Research Laboratory [CERL], 1975).

⁴*Military Construction Progress Reporting*, ER 415-345-43 (Department of the Army, 31 March 1972).

⁵*Planning and Project Authorization-Military Projects*, ER 405-345-100 (Department of the Army, 26 March 1973).

MASTER PLAN DEVELOPMENT, BASIC FUNCTIONS

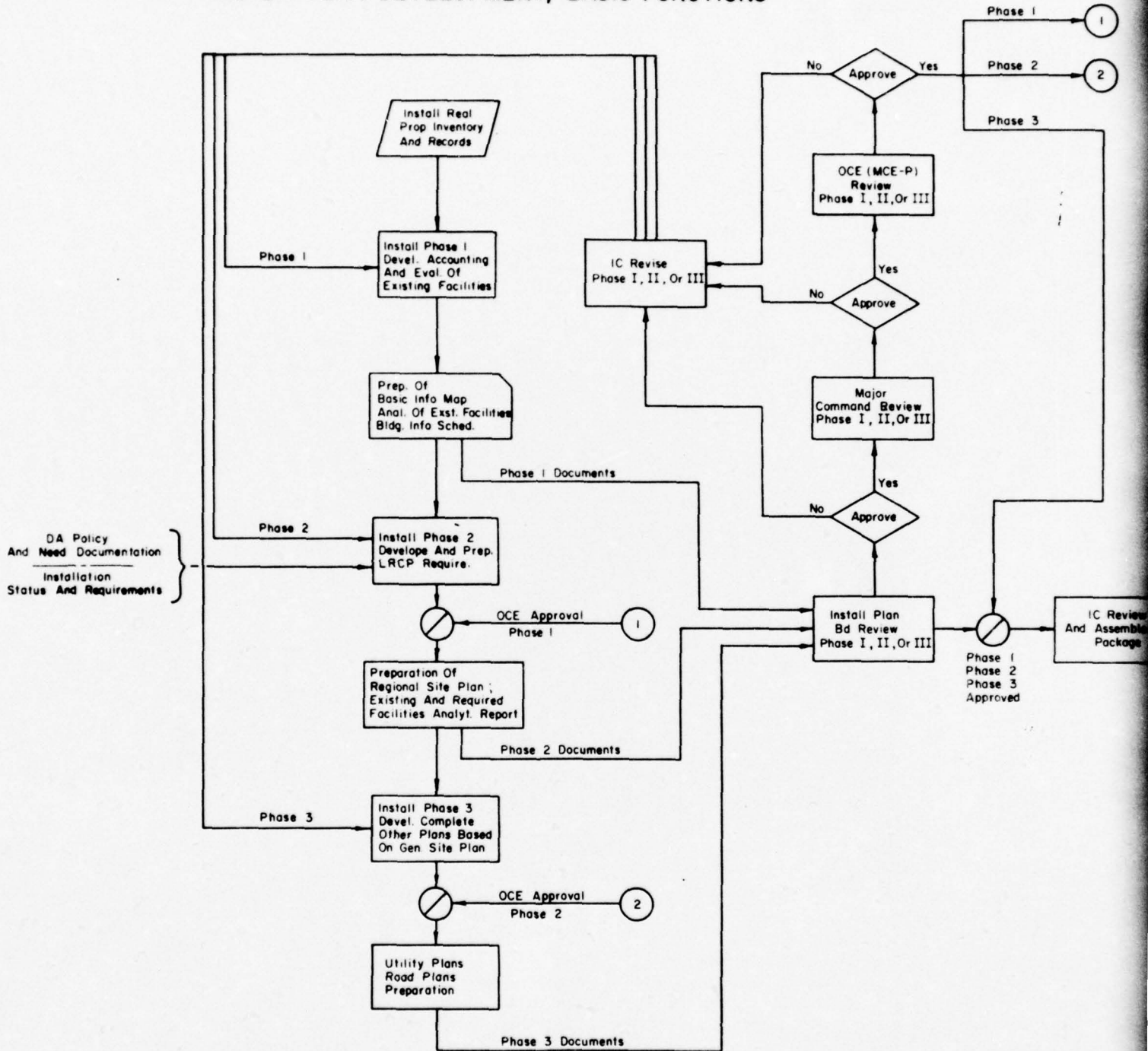
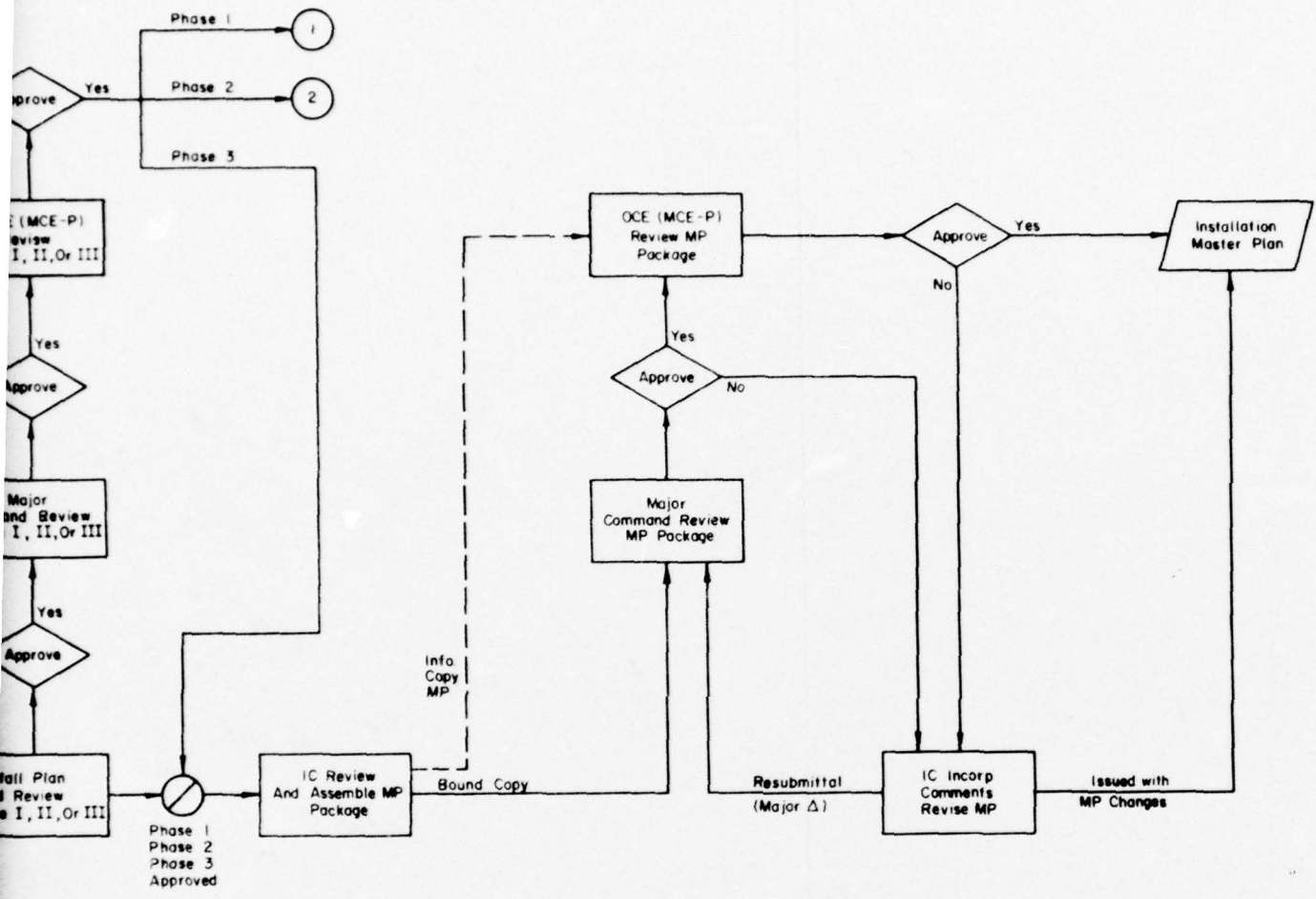

Figure 6. Installation master plan development, basic function information flow network.



2

Table 2
Master Plan Documentation
(AR 210-20)

- Phase 1 Documents:
- Basic Information Maps (BIM)
 - Analysis of Existing Facilities
(Real Property Assets: DA Form 3640)
 - Building Information Schedule (BIS)
DA Form 3640 Printout
 - Preliminary Land Use Plan
(Optional - when a general site plan is unavailable)
- Phase 2 Documents:*
- Tabulation of Existing and Required Facilities
(DA Form 2369-n-R)
 - Analytical Reports and Engineering Assessments
 - Regional Plan
- Phase 3 Documents:
- Utility and Site Plans

*Phase 2 documents are submitted by the IC as a unit, and provide the Assistant Chief of Staff for Force Development with information for use in staff planning actions.

the functional flow of installation support to this development.* The resulting MP can have either two or three phases, since adequate planning can be accomplished with only Phases 1 and 2 complete.

The enabling documentation used to implement MP revision and/or project-proposal developments are the previously referenced planning and control reports, the IRCP revision forms (DD Form 1390), and the PDB-1. Hence, the MP interfaces with planning and control reports that specify or impact installation needs, project scope, and real property status activities. Ideally, the MP consists of the documentation for all three study phases. However, since early planning requires only the first two outputs, many installations are supplying these two parts as a working MP, with the complete plan to be developed at a future date.

Construction Planning

Installation planning for the IRCP and SRCP differs in the amount of detail provided, not in the reporting mechanism. The IRCP requires a "short" DD Form 1391 while the SRCP requires a full DD Form 1391 submittal. The IRCP revision is implemented by the

*See the *Installation Expansion Capability Guide*, TB ENG 354 (Department of the Army, 15 March 1976).

DD Form 1390 and impacts the DD Form 1391 and thus the PDB-1 as shown in Table 3.

Table 3
Program and Project Information Forms

DD Form 1390

Lists proposed construction for IRCP in **priority sequence** (by command); information required for this form may be obtained from basic construction location and scheduling plans, from the "Inventory of Army Military Real Property" card, and from DD Form 1391 data.

DD Form 1391

Prepared for **each** project requiring OSD approval; submitted in the budget year plus one, regardless of previous submittals. (The 1391 is also prepared for urgent construction and added to the SRCP after the fact.) The form requires a detailing of the scope of the proposed construction. Selected example entries include:

- Space 18 - Floor area/no. of stories/designed capacity, people/cooling costs
- Space 19 - Features of Construction
- Space 20 - Components
- Space 21 - Supporting Facilities
- Space 22 - Total Project Cost
- Space 23 - Quantitative Data (Existing Structures, etc.)
- Space 24 - Related Projects
- Space 25 - MCA Funding of Equipment Justification of Project

Installation Real Property Status

OCE maintains an effective Real Property Inventory (RPI) for continental United States (CONUS) and foreign Army installations. Each installation reports changes in their RPI to OCE quarterly for automated checking and inclusion in the Central Inventory of Army Military Real Property. In turn, OCE provides the installation with an annual printout of their registered facilities for error correction (Figure 7). The RPI and associated data are considered primary documentation by each Installation Planning Board (IPB).

Inputs to the RPI updating system are made quarterly and include newly transferred facilities and any required detailing or corrections to previously identified structures. This requires the development and submittal of real-property/facility reports (DA Forms 3641 and 3640) by the IC to the Data Processing Unit of his Field Command Headquarters. These ADP data are then forwarded to the MACOM, which provides the data to OCE in the appropriate format.

OCE, in turn, provides each installation with an annual printout (DA Form 2541) of its official recorded real property status.

RPI UPDATING DIAGRAM FOR ARMY CONUS INSTALLATIONS

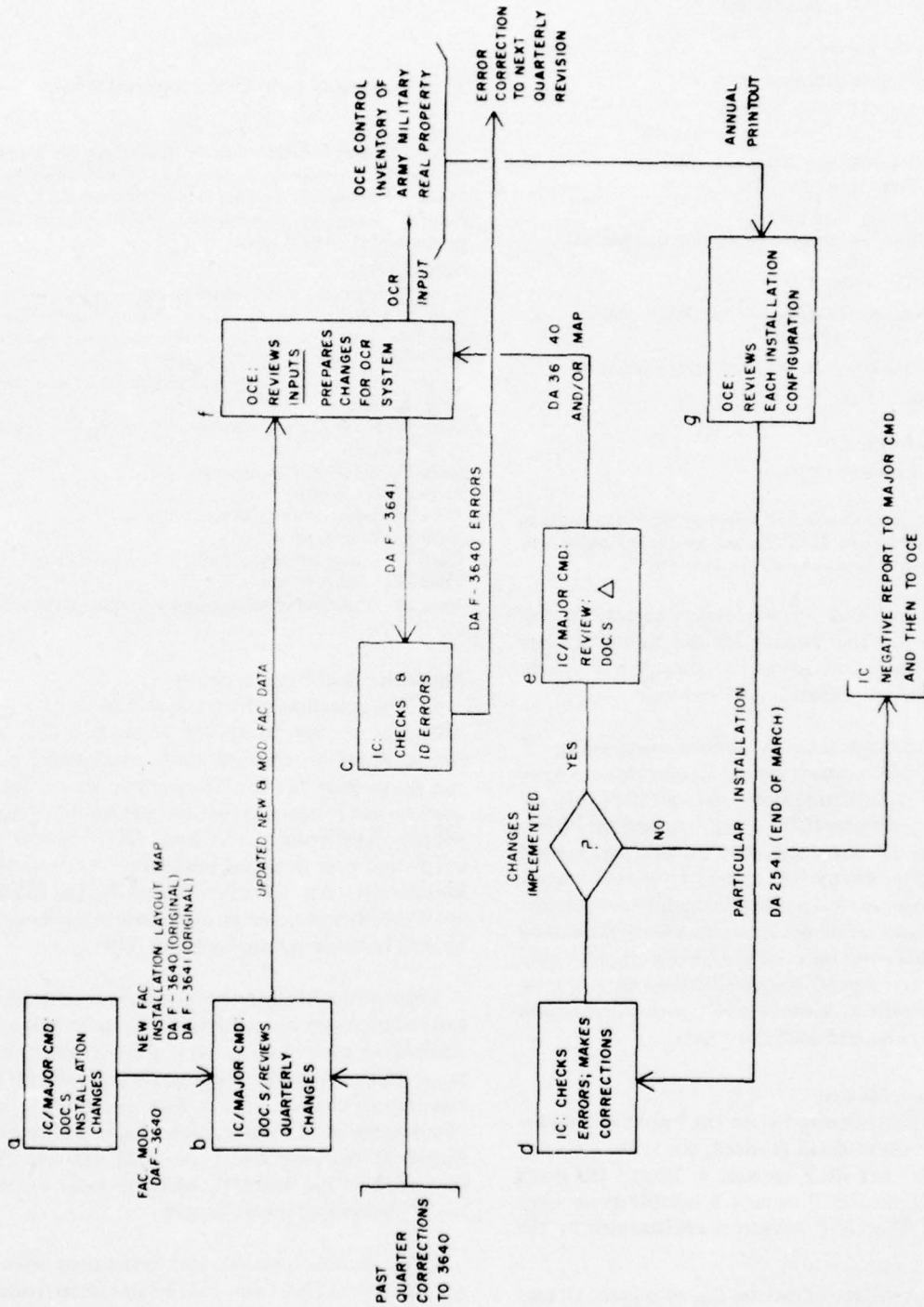

Figure 7. Army Real Property Inventory (RPI) system before implementation of IFS.

The forms used to implement and update the RPI System are:

- DA Form 2014R: Army Leaseholdings in Foreign Countries Separate From Installation
- DA Form 2541: Installation Inventory of Military Real Property (Printout)
- DA Form 2877: Real Property Record Card
- DA Form 3641: Real Property Assets; Contains Facility Data Records I and II - General Installation Information
- DA Form 3640: Facility Data Update (OCE Revision Implementation);
Record III - Real Property Information
Record IV - Building Information Schedule (BIS for MP-1)

Status Determination after IFS Implementation

Modified procedures will be required at each installation after implementation of IFS to permit maintenance of the RPI and BIS documentation. After the IFS implementation, installations will not submit DA Form 3640 but will use the following procedure:

1. At the end of each fiscal quarter the Management Information System Office (MISO) will produce magnetic tape copies of the Installation Management and Planning (IMP) file, and Force and Mission Planning (FMP) file for all installations processed at the Data Processing Installation (DPI).
2. The tapes will be forwarded quarterly to HQDA, Office of the Chief of Engineers, ATTN: DAEN-FEM-S, Washington, DC 20314.

The assets data base is extracted from the OCE RPI/BIS files approximately 6 months before the installation cutover date. Copies of DA Forms 3640 submitted after that date are retained. This information is then loaded into the IFS at the start of data base build which is scheduled 3 months prior to implementation.

Procedural Categories in MCA Project Development

Although all MP entries for an installation are handled similarly, they may not be identically implemented during the programming phase. When the user is other than the IC (as for medical facilities), or when complex technical or safety considerations are involved, special

review or control requirements may apply. Furthermore, when funding is by other than MCA appropriations, different budget review and control responsibilities are incorporated into the programming cycle.

Procedural variations required for the different categories of MCA project development can result in corresponding variations in information flow within the Corps. The most significant procedural influences are from funding-source differences and from differing user requirements.

Procedures Categorized by Funding Sources

MCA major construction projects are developed in accordance with the requirements and restrictions of their funding categories; each category implies specific funding and sequencing criteria:

1. **MCA Funding.** MCA-funded major projects must be supported by a District budget study and subsequently must be specifically funded by Congressional appropriation, as illustrated in Figure 5.
2. **Family Housing Funding.** Family Housing is a separate appropriation, whose distribution is controlled by the Secretary of Defense according to strength assessments and the FYDP (Figure 8).
3. **New Start Funding.** New Start funds are allocated to the replacement, maintenance, or updating of commercial/industrial-type facilities necessary to a base.
4. **Reimbursable Funding.** Revenue-generating facilities may be built with nonappropriated funds on approval (Figure 9).

Special User or Review Board Requirements

Review requirements for development decisions and design products may be altered by the type of facility and the associated user. The following are examples of special user or technical requirements.

1. **Installation Commander.** Specialized review approval requirements for specific types of MCA projects include:
 - a. **Data Processing Center (DPC).** All DPC equipment and facilities must be approved by the DA.
 - b. **Facilities for explosives, ammunition, and toxic/corrosive chemicals** must be approved by the Explosive Safety Board (DESB).

REIMBURSABLE FUND PROJECTS

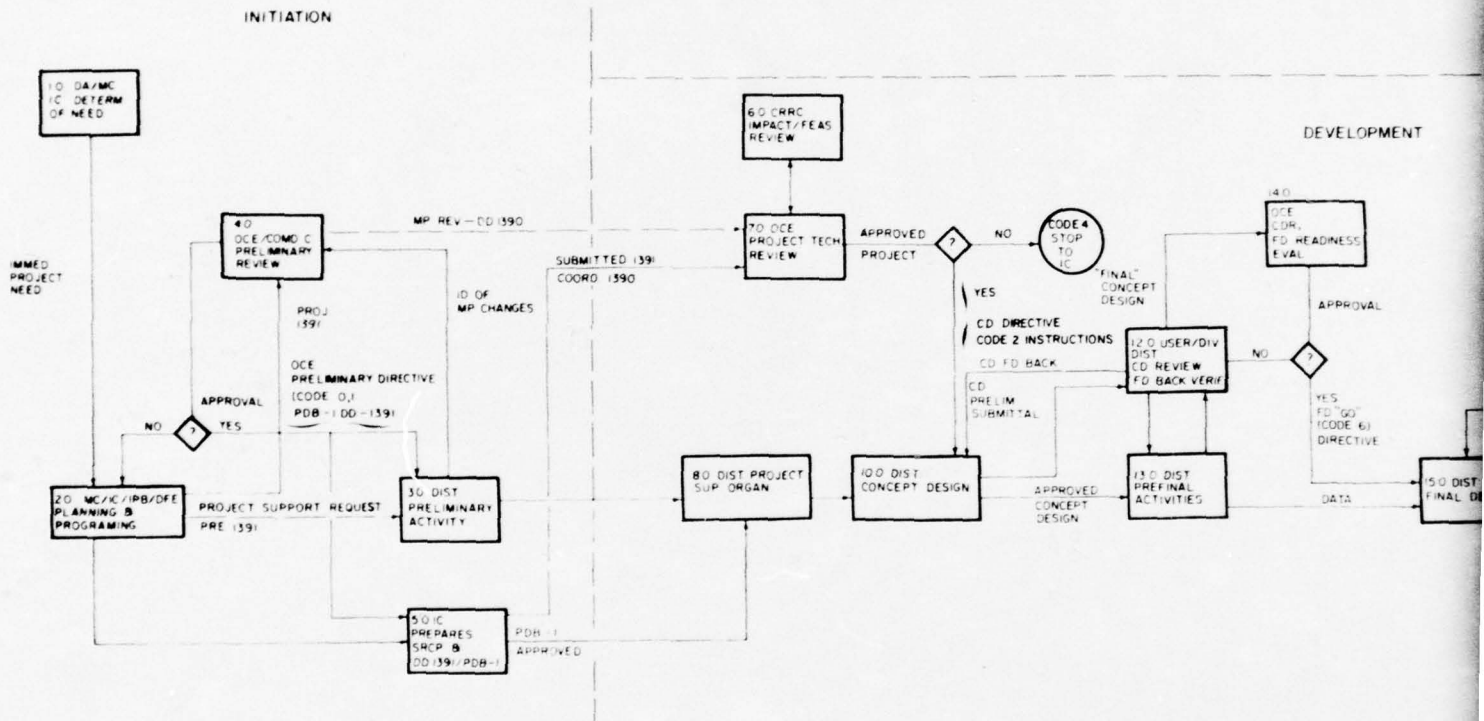
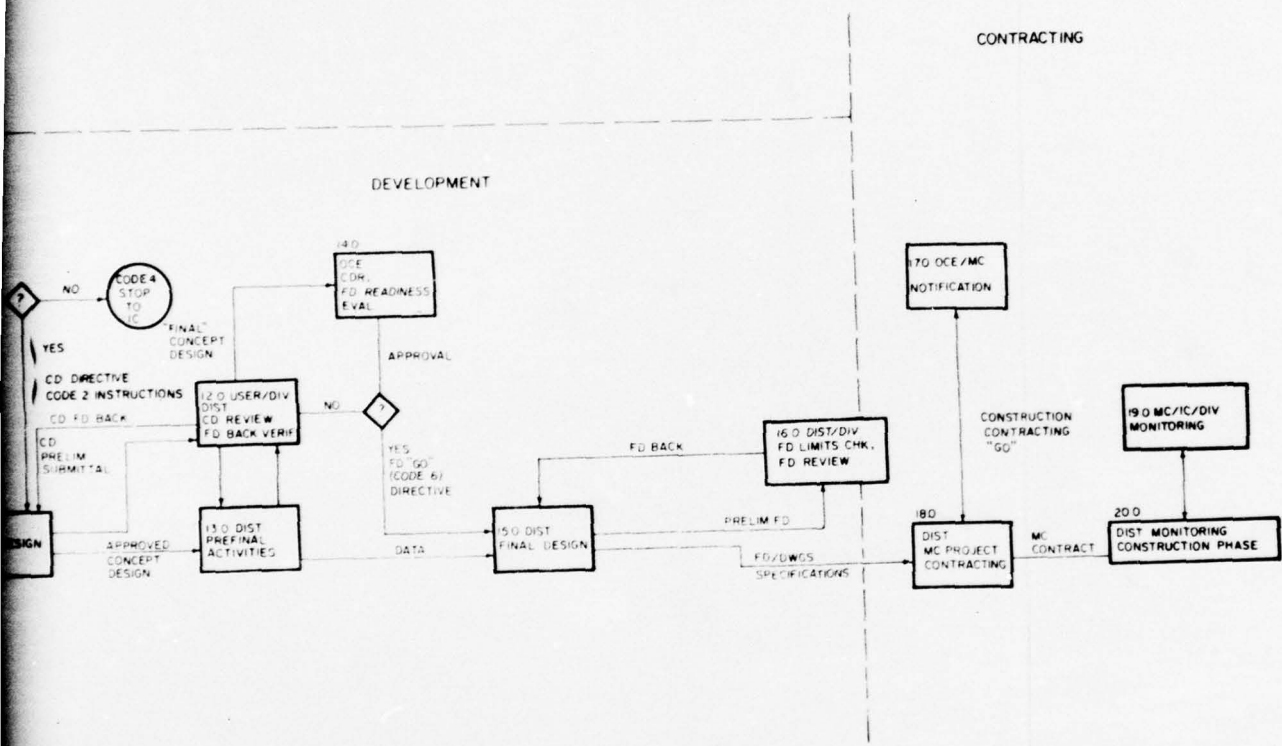

Figure 9. Performance area network for MCA projects with reimbursable funding.



ing.

2

c. New Start Facilities. New Start costs which exceed specified limits must be approved by the Assistant Secretary of the Army or higher.

2. Medical Facilities. All base medical facility projects are under the Office of the Surgeon General (OTSG), which is considered the user agency. Concept-design of hospitals must also be provided to OSD for review and approval.

3. Detention Centers. Although the IC is considered the user for all base facilities except medical, in the case of detention centers, the Provost may perform a "user" support function for design approval and security requirements.

4. Commissaries and Mess Halls. By regulation and agreement, the Troop Support Agency (TSA) supplies the criteria and planning assessments for food-handling facilities to the IC as user agency.

Other Procedural Influences

Regulatory restraints and local District practices have significant procedural influence on MCA project development. The controlling mechanisms applied to MCA procedures are derived from legal or regulating restraints, DA directives and instructions, and local District adaptations of these regulations and guidance.

Regulatory Restraints

The influence of procedural regulations on information flow during the programming phase is apparent. General procedural requirements for specific situations are provided in ARs, ERs, and other official regulatory publications. Cost criteria for contracting and procedural review are detailed in ASPR, Chapter 18 and summarized in ASPR, Appendix B to identify regulations and corresponding report forms which affect MCA programming and design procedures. The DD, DA, Engineering, and Special Forms customarily used to develop or manage the MCA project are listed in Appendix G.

District Adaptations

The Districts have developed various procedures in response to the same controlling criteria in order to optimize use of local manpower skills, and to meet the unique responsibilities evolved from geographical area and task-spectrum characteristics. The variations in section designations and group assignments for four Districts are developed in Section A-3 of Appendix A for basic major military construction projects. Appendix G identifies the forms used to support MCA projects for the Savannah and Sacramento Districts.

4 DEVELOPED INFORMATION FLOW NETWORKS

Detailed information flow patterns vary according to six major categories of users—Army, Army Reserve, Air Force, National Aeronautics and Space Administration (NASA), North Atlantic Treaty Organization (NATO), and Foreign. Even within a particular category, many procedural exceptions are possible for specific projects or circumstances. Appendix A contains detailed information flow networks for major construction projects (total project cost greater than \$400,000), with supplementary charts for minor construction and family housing projects. The networks must be interpreted in accordance with their objectives and intended applications. Since the networks were developed from what are considered to be the most typical MCA project procedures, they may be taken as generally true within the context of the presentation. However, no feasible number of networks could account for all possible procedural exceptions derived for specific projects or circumstances.

Structural Pattern of the Networks

As previously described, the general pattern of the information flow model contains an overall "top" procedure, a functional "middle," and a detailed "bottom" flow. Each block in the "top" flow represents a set of subblocks in the "middle" flow, which, in turn, represent corresponding sets in the "bottom" or detailed flow.

The functional blocks are sequentially ordered to represent their generally observed occurrence. The actual start and finish of an activity should not be inferred from the block geometry; no time-base is provided, and the space between blocks has no significance. Of course, in actual practice each activity blends into the next; thus the grouping of activities into a functional block is a semantic simplification.

Functional Content of Blocks

Each block in the top flow (Figure 5) identifies a performance area which incorporates primary functions at the middle and detailed functions at the bottom levels.

Block 1: Determination of Need

Block 1 provides a representation of the need realization and identification process. Army installation needs are the responsibility of the IC in consultation with the appropriate MACOM (designated Maj C on flow networks), under the policy direction of the Department of the Army (DA).

General MCA program policy is derived from the FYDP maintained by the Secretary of Defense (SOD), and the Army Stationing and Installation Plan (ASIP) developed by the Assistant Secretary of the Army (Installations and Logistics) (ASA [IL]) from the FYDP and military planning documentation. Facility needs are developed from assessments of installation status and MACOM strength support requirements. Additional influences on base facility requirements stem from changing standards and criteria and the assumption of new support roles.

Block 2: Planning and Programming

The needs defined in Block 1 are developed into facility requirements in Block 2 by the Installation Planning Board (IPB), which, in communication with the MACOM activities of Block 4, develops sufficient facility characteristics to permit generation of a DD Form 1391 and the PDB-1 by the IC in Block 5. The IPB correlates base needs with what is considered feasible, and further develops MP and IRCP entries, or proposes new facilities with added judgments as to scheduling and priorities. The IPB (defined in AR 210-20) consists of the following members:

1. IC - Chairman
2. Facility Engineer
3. Technical staff personnel
4. Division Engineer (Div E)
5. Commanding Officer
6. Associate (nonvoting) members.

The District Engineer (DE) may be an associate member. Since the District Engineer often represents the Division Engineer at IPB meetings, the District can be oriented to installation real needs and necessary planning.

The IPB function may be reactivated at any time during project programming and design, when programming operations alter the criteria or scope of the originally proposed facility.

The formal facility requirements are always reviewed by the "user" (AR 415-10⁶).

⁶*General Provisions for Military Construction*, AR 415-10 (Department of the Army, 15 March 1972).

The facility requirements are developed in accordance with DOD Construction Guidelines (DOD 4270.1M⁷) and the TM 5-800 series. Procedural requirements are specified in appropriate MCA regulations (AR 415-15⁸). Sources of MCA requirements may be identified according to status or type:

1. Status

a. Urgent (not in MP): AR 415-15

b. Planned (in MP): AR 210-20

2. Types

a. Troop Support Requirements: AR 10-41 through 43⁹

(1) Bachelor Housing

(2) Community Facilities

(3) Food Service

(4) Health

(5) Training

b. New-Start Commercial/Industrial Cost Limits: AR 235-5¹⁰

c. Explosive/Ammunition/Toxic-Chemical Facilities

d. Data Processing Centers (DPC)

e. Pollution Control Systems (>\$50,000): AR 11-21,¹¹ AR 200-1¹²

⁷*Construction Criteria Manual*, DOD 4270.1M (Department of Defense, 1972).

⁸*MCA Program Development*, AR 415-15 (Department of the Army, 8 May 1969).

⁹*U.S. Army Training and Doctrine Command*, AR 10-41 (Department of the Army, 27 June 1973); *U.S. Army Forces Command*, AR 10-42 (Department of the Army, 15 April 1975); and *U.S. Army Health Services Command*, AR 10-43 (Department of the Army, 5 February 1975).

¹⁰*Management of Resources—Commercial and Industrial-Type Functions*, AR 235-5 (Department of the Army, 6 November 1974).

¹¹*Environmental Pollution Abatement*, AR 11-21 (Department of the Army, 3 November 1967).

¹²*Environmental Protection and Enhancement*, AR 200-1 (Department of the Army, 14 November 1975).

Projects which have been accepted by the Major Command and the installation are released for PDB-1 development, associated real estate acquisition studies, and any special or environmental impact reviews. At this time the District may also be informally alerted if the project is large, and the District has had no previous participation.

Special-agency reviews of certain installation facility planning and construction include:

1. Defense Department Explosive Safety Board (DDESB)
 - a. Explosive/ammunition handling and storage
 - b. Toxic chemicals storage
2. Office of the Surgeon General (OTSG)
 - a. Base hospitals
 - b. Medical clinics
 - c. Dental clinics
3. Assistant Secretary of the Army – New Start (industrial/commercial-type facilities) cost overruns
4. Department of the Army (ASA [I&L])–DFCS
5. Troop Support Agency (TSA)
 - a. Post exchanges
 - b. Food preparation facilities and systems.

Block 3: District/Division Preliminary Activities

Preliminary activities for a District and associated activities for the Division include project and MP evaluation, status monitoring, impact assessment, and gross scheduling.

At the request (with funding) of the IC, the District performs support to proposal development, definition, and MP impact evaluation. If technical feasibility studies are required for complex nonrepetitive projects, the District can be delegated project funds; it then contracts and manages the analytical study. When District support is requested without adequate funding, the District may generate a "Request for Predesign Funds" to remedy the oversight.

Block 3 contains the following District activities:

1. Identification and recording of the projects, and review of the current design criteria, as derived from IPB/Facility Engineer communications, OCE instruction/directives, and the CE Operations Plan (CEOP).
2. Authorization (directive) from OCE.
3. Assessment of project scope and funding from DD Form 1391 and CEOP sources.

Block 4: Major Command Review

The MACOM budget year (BY) construction program for all installations under the Command is developed according to annual DA policy/funding letters, DOD/DA documentation, and installation BY or SRCP project proposals (preliminary DD Form 1391). The goal of the MACOM review is a balanced construction program, meeting local installation requirements within DOD/DA requirements and funding limitations. Review procedures for both U.S. Army Forces Command (FORSCOM) and U.S. Army Training and Doctrine Command (TRADOC) are provided by the basic function networks for Block 4 in Appendix A.

Block 5: Preparation of Project Data

After sufficient study and coordination, the proposed facility is added to the annual MP revision or the developed construction program, according to the immediacy of the need. The minimum construction cycle for a major proposal is 3 years. These proposals are designated for the SRCP after approval, with projects beyond 6 years defined as intermediate (IRCP). For each project in the SRCP construction year, a detailed justification and a completed DD Form 1391 signed by the IC must be provided OCE (Block 6). Additional site data are added to this material to constitute the PDB-1, which is now the basic project input to the District.

Block 6: Project Technical Review

OCE provides technical review and supports the evaluation by the CRCC and the Budget Review Committee (BRC) at the DA staff level for each proposed MCA project.

Basic project and SRCP data for each installation are provided by OCE to CRCC for the committee's detailed evaluation of appropriateness, compatibility with current policy, general impact, cost benefits, and general technical feasibility.

CRCC's rating, expected funding levels, and project cost determine whether the project is accepted, deferred, or rejected by DA.

Project DD Forms 1391 with budget attachments are reviewed in the priority order that OCE estimates CRRC will assign to the projects. The forms are reviewed by specialists in each information area covered, with OCE-annotated copies provided to OSD/DA for funding on approved subjects and to the Division/District with a directive for study or design implementation. Each project's short form (first page) of the DD Form 1391 and each installation's DD Form 1390 for the total SRCP are included in the "Green Book" (GB), to be adjusted and finalized in Block 7 for presentation to OSD, OMB, and Congress.

Block 7: Project Evaluation and Representation

OCE further evaluates MCA projects preparatory to providing the formal presentation material to OSD/OMB for use in defining the Army Program in Congressional authorization and appropriation reviews. The adjusted 1390/1391 forms, tailored by OCE to meet estimated OSD acceptable levels, are submitted to DA and OSD/OMB in the preliminary GB. OCE uses the DA/OSD review comments to adjust the GB to meet OSD requirements.

The formal GB is then sent by OSD/OMB to the Congressional appropriations committees. If the appropriations bill and subsequent apportionments include a particular project, it is scheduled into the budget year for the SRCP appropriation.

Block 8: District/Division Budget and Project Coordination, MCA-Funded Projects

Upon receipt of one of several possible design directives or a pre-design study (budget) directive from OCE, the District actively supports the MCA project. Generally, this support takes the form of a Preconcept Control Data Package (PCDP) provided to OCE (MCE-S), Block 7, for review and use by the OCE representative at Congressional hearings if the project is questioned.

The PCDP usually consists of a site plan, a gross building plan, outline specifications, and the Current Working Estimate (CWE) for Budget Purposes (ENG Form 3086). If the project requires a repetitive or standard design, OCE may specifically request only the ENG Form 3086.

Block 8 contains the following District activities:

1. Receipt and evaluation of the PDB-1 containing project instructions and criteria
2. Request for funds sent to OCE with affirmative reply
3. Establishment of funding schedule
4. Preparation of a budget estimate CWE on ENG Form 3086
5. Completion and submittal to OCE of the PCDP with site plans, a building plan, the CWE, and any supporting narrative
6. Correlation and/or resolution of District/Division interpretations with installation criteria.

Block 9: District Organization of Support

Organization of support for a MCA project officially begins when some implementing directive is received from OCE. Although the District may perform a rough scheduling and preliminary design-scope determination when first learning of a major project, significant District support actually begins only after the issuance of a directive by OCE. This support begins with designation of a Project Manager and determination of whether the future design will be in-house or contracted to an AE.

Although the AE selection and contract negotiation process is one of the District's largest tasks, it is fundamentally an internal operation of the District and thus is included in the Block 9 organizational function. However, at specified levels of project costs or accumulated fees by the selected AE, appropriate increased levels of DA/DOD approval are required.

Procedures for effecting design-performance control and for performing the development, negotiation, and management of the AE contract are included in Block 9, which contains the following District activities:

1. Scheduling of internal District activities and manpower contingent on receipt of funds
2. Determination of in-house or AE design support
3. Receipt of support funds from OCE
4. Appointment of Project Manager and development of objective design schedule

5. AE contracting procedure. The AE contracting procedure can be broken into three major steps, each containing a number of specific activities:

a. Implementation of the AE selection process

- (1) Synopsis of project and AE contract plans
- (2) List of qualified AEs called-up from computer and provided with advance notice
- (3) Advertisement placed in CBD
- (4) Preselection Board lists five to 10 AE firms
- (5) Selection Board narrows list to three with priority ratings
- (6) Highest priority selection approved by each required level.

b. Negotiation of AE contract

- (1) AE notified of selection
- (2) Predesign conference held (optional)
- (3) AE evaluates task
- (4) AE audited
- (5) Prenegotiation conference held
- (6) AE determines fee; transmits to District negotiator
- (7) Negotiations conducted, agreement reached.

c. Implementation of AE contract

- (1) Design work implemented by Contract Letter Award (CLAW)
- (2) Contract prepared from negotiation minutes
- (3) Approval of AE and contract
- (4) AE and contracting officer sign contract.

Block 10: Concept Design (CD)

Concept design is performed by the District either in-house or by delegation (negotiated contract) to an AE firm, as determined in Block 9. When AE services

are used, the CD may be initiated by transmittal of a contract letter award (CLAW), prior to a formal contract signing. Management of the concept design phase is handled by the District Engineer. Regardless of the design route chosen, the procedure for the concept design phase is the same.

The actual facility design (AE or in-house) is performed according to the estimating techniques inherent in a concept design and should not be carried further than 25 percent completion. The procedure is iterative in nature, balancing the requirements of structural and habitability planning. During the CD phase, the Project Manager may request informal or formal progress reports (PR) from the AE.

Prior to completion of the CD, preliminary submittals are made to the user and the DE by the designer. Several may be made before satisfying the CD review function of Block 12. The Division Engineer may screen user, installation, MACOM, and other comments on the completed CD for intent, feasibility, and legality in order to provide the District with a clear revision task. When all feasible/admissible comments are incorporated, the AE or design group provides the "approved" CD to the District for final review and coordination (if directed) with OCE.

Block 10 contains the following AE or District Design Branch (DB) activities:

1. Scheduling of entire project according to mandatory periods and sequential criteria provided by the District Engineer
2. Preparation of architectural concept design (CD)
3. Maintenance of a budget review and design cost analysis program
4. Development of
 - a. Facility siting and general site planning
 - b. Preliminary building layout
 - c. Preliminary utility design
 - d. Basic structural planning
5. Maintenance of CD for coordinated AE/District or DB/Project Manager (in-house) reviews as scheduled

6. Preparation of CD (25 percent completion) for release to user and Command Review.

Block 11: OMB, OSD, and DA Review Policy Status

OMB, OSD, DA staff, and the BRC review each major construction project to be submitted to Congress for compatibility with stated DOD and DA goals and limitations.

Project information provided the OSD is an annotated DD Form 1391 (short-form) and a detailed justification narrative. The SRCP information (DD Form 1390) for the installation program and the DD Form 1391 data for each project are reviewed and updated where needed and then used to revise the Green Book for Congressional review.

The OSD primarily checks to see if a proposed project is on their approved list and if sufficient detail is included to make the project and its impact understandable. When greater detail than provided by the Green Book is desired by Congressional committees, it is provided by OCE representatives.

After several successive Congressional committee reviews, an appropriation bill and amendments which eventually become law evolve. If the project of interest survives, a notification of its funding is supplied to the user, the installation, and the interested Division Engineer. Subsequently, an authorization is provided the District to proceed with construction activities.

Block 12: Concept Design Review (CDR)

The CDR insures that the Concept Design complies with the user's instructions and criteria, including cost, scope, consistency, and other specifications. The Division Engineer screens and integrates his own and other comments made by the user Installation Commander for transmittal to the DE. Corrections are made to the Concept Design by the District with AE assistance. If the design is performed in-house by the District, the Division Engineer must also approve the design. (Except for areas of special interest, no CDR responsibility rests with the Division Engineer for AE-designed facilities.)

The CDR controls the criteria developed for the Final Design and is the last stage for possible adjustments to outmoded aspects of the original planning. Hence, the CDR depends largely on user review with District/AE assistance. Significantly modified building plans require additional OSD approval.

The District collects and maintains all CDR records until facility turnover and acceptance.

Block 13: District Prefinal Activities

This function is the coordination preparatory to Final Design (FD), and contains the following District/AE activities:

1. Consolidation of concept-design comments and data for AE or Design Group implementation during FD
2. Site surveys and soil/foundation studies (if not performed prior to design phase), when required for detail design or construction cost estimating
3. Confirmation of construction contract period from the CD scope, the funding schedule, user requirements, projected construction rates, and any potentially limiting interfaces.

Block 14: Final Design Readiness

A readiness evaluation before FD permits a full critique of the CD and CDR by OCE. It also allows marshaling of all "second thought" and modification proposals for complete evaluation before design commitment. Upon resolution of all problems, the Division Engineer requests FD authority from OCE. Issuance of the FD Directive initiates Block 15.

Block 15: Final Design

The FD is generated on the premise that no further design criteria changes will be made. When the FD phase is completed, 90 percent of the actual facility design has been completed. The remaining 10 percent is contingent on the final preparation of the facility design for OCE and Division signatures of approval.

Block 15 contains the following AE or Design Branch activities:

1. Development of final design in accordance with an approved CD and accepted CDR recommendations
2. Continuing cost analyses, supplying 60 percent cost estimate for District Engineer review
3. Finalizing building design
4. Finalizing utility plans
5. Finalizing architectural/structural specifications and drawings
6. Provision of CWE and support data to develop the Government Estimate.

Block 16: Final Design Review (FDR)

A preliminary FD is provided to the District by the AE or to the Division Engineer by the District Design Group to check for compatibility with the established objectives. Special design review boards may be required as specified in AR 385-60¹³ or AR 190-13.¹⁴ The completed FD is not reviewed by the user (although in-process reviews may be made).

Block 16 contains the following District and/or Division activities:

1. Review of AE/Design-Group computation and analysis and back-checking of the FD by the District
2. Review of FD for compliance with criteria, scope, and cost estimates
3. If necessary, return of FD to AE for corrections
4. Release of FD to Bid-Package Development; notification to user and Division Engineer of design completion
5. Preparation of the CWE for control purposes and the Government Estimate for bids review.

Block 17: OCE/Major Command/Division Notification

The Comptroller of the Army (COA) transmits Congressional allocation information immediately after notification by SOD. The supervisory Division formally notifies the District about each project, and the District begins construction-contracting procedures. The formal notifications are sent immediately after the appropriation and allocation of project funds, and may occur at any time after the OCE design directive. (Only about 5 percent of all projects must wait for construction funding after final design.)

Block 18: MCA Contracting

The contracting phase of project development begins with development of a Construction Contract Schedule at near-completion of the FD. Some Districts (Savannah) carefully weigh project needs and resource availability to determine optimal sequences. Due to work volume, other Districts must contract according to availability of District personnel. In any event, the functional

¹³Coordination With Armed Services Explosives Safety Board, AR 385-60 (Department of the Army, 20 December 1971).

¹⁴The Army Physical Security Program, AR 190-13 (Department of the Army, 23 August 1974).

procedures of advance notice, CBD advertisement, bid package preparation and distribution, bid opening, pre-award survey, contract award, and Notice to Proceed (NTP) generation are the same.

Block 18 contains the following District activities:

1. Construction-contract development
 - a. Identification of critical construction and phasing requirements (methods, materials, and scheduling)
 - b. Determination of liquidated damages from user potential loss
 - c. Obtaining wage labor rates
 - d. Preparation of special provisions and other data to finish contract
2. Preparation of **contract** and **Title I Documents**, reproduction of plans and specs, and binding and distribution of Bid Package for review by District/Division
3. Obtaining **fund certification** for construction or a directive to proceed to bid opening pending funding availability
4. Performance of bid-contracting procedure
 - a. Advance notification to bidders on qualified list
 - b. Preparation of synopsis and placement of advertisement in CBD
 - c. Distribution of bid-package to responders
 - d. Processing of amendments necessitated by bidders' comments
 - e. Hold for funding certification if not received 10 days before scheduled bid opening
 - f. Performance of bid opening and declaration of low bidder
 - g. Performance of preaward survey
 - h. Convening contract awards board and awarding contract to lowest responsive bidder.

5 REVIEW OF DEVELOPED CE NETWORKS

The information flow networks presented in the appendices are developed for the CE procedural requirements of CONUS and foreign military construction. Three-level flows are provided for MCA CONUS in Appendix A, and one-level flows are provided for MCA Foreign, Army Reserve, Air Force, and NASA construction in Appendices B, C, D, and E, respectively. These developed networks are considered to be the most instructive networks for the purposes of the general reader.

MCA Projects, CONUS

CONUS Army installation construction projects can be differentiated by funding source as described below.

MCA-Funded Projects, Minor Construction

A simplified CE procedure (AR 415-35¹⁵) is used for programming, design, and construction of Minor Construction (equal to or less than \$400,000), as shown in Appendix A. Minor construction has two sub-categories—**urgent** and **standard**.

Urgent Minor Construction (UMC) is so designated after generation of a Certificate of Urgency at the installation level (for projects greater than \$50,000) and approval of the project at the SOD level (AR 415-20¹⁶). If the CE does not begin construction within 180 days after UMC signing, the appropriation is cancelled by regulation. This effectively allows 30 days for initiation and programming, 10 days for AE negotiations and contracting, 90 days to design, 30 days to prepare drawings, and 20 days for a crash construction bidding procedure.

MCE-Funded Projects, Major Construction

MCA Major Construction constitutes the general (and largest) category of construction. By definition, such projects exceed \$400,000 and are part of the annual review, authorization, and appropriation activities of DA, OSD, OMB, and Congress described in Chapters 2 and 3. The network models for MCA Major Construction provided in Appendix A show the procedural complexity, including DA staff, OSD, OMB, and

Congressional review levels. Unique to these flows is the "Preconcept Control Data Package," prepared by the District for OCE as a detailed predesign budget review and advocacy support at Congressional hearings.

MCA-Funded Projects, Bachelor Housing

Troop strength at an installation varies with military positioning requirements and the general Army strength level. Bachelor housing (BH) requirements directly reflect these variables and present the greatest forecasting problem in MCA planning. The IC supplies BH status to OCE periodically on DA Form 1709R and DD Form 1757, which are used to substantiate any DD Form 1391 BH construction proposals.

DA Form 1709R—Bachelor Housing Capabilities and Utilization. This form is a status statement used for defining existing bachelor housing capabilities and deficiencies in the stationing of troops. It is also of value to mobilization planning documents, as input to the data base of the stationing capability system, and as a basis for replying to high-level inquiries. Installations are required to submit the form *semi-annually* to Installation Planning Division, Assistant Chief of Engineers (ZCI). (Some installations, listed in AR 210-18,¹⁷ are required to submit it **quarterly**.) Information from the form is also used in lines 8 through 10 of DD Form 1657.

DD Form 1657—Determination of Bachelor Housing Requirements. Every Army installation with bachelor housing projects programmed for construction or modernization must submit DD Form 1657 **by 15 May** each year to OCE (MCE-P), with one copy to Program Division, Assistant Chief of Engineers (ZCP). The form must also be submitted to validate projects in FYDP and to revalidate those approved by Congress prior to construction. Sources for completing the form are DOD 4270.1-M, ASIP, and AR 415-15. Preparation instructions and a definition of bachelor housing minimum adequacy requirements are given in AR 210-18. Several entries on DD Form 1391 are based on data from DD Form 1657 and are usually checked against it. It is assumed that the DD Forms 1657 are received at OCE prior to receiving DD Forms 1391.

Family Housing Management Agency (FHMA) Funded Projects, Minor Construction

Simplified MCA procedures are used for Family Housing Minor Construction, as described in "MCA Funded Projects, Minor Construction."

¹⁵Minor Construction, AR 415-35 (Department of the Army, 16 July 1970).

¹⁶Project Development and Design Approval, AR 415-20 (Department of the Army, 28 March 1974).

¹⁷Bachelor Housing, AR 210-18 (Department of the Army, 14 January 1975).

Family Housing Projects, Major Construction

Family housing (FH) new construction procedures have been adapted to meet the realities of government and contractor capabilities. Because CE expertise does not include the techniques of FH construction, construction of large FH tracts requires appropriate contracting. Hence, MCA network descriptions are **not** applicable to family housing, since CE practices are here directed to the acquisition of large, specially qualified contractors.

Initial FH procedures reflect the special programming requirements for both detail review and fast response. Family housing is developed on a 6-year plan with the execution (current) program and the legislative (next FY) program of greatest interest. The annual data generated for these development phases are identified in Table 4 (AR 210-50¹⁸). This procedure is shorter than MCA major construction, being based on an IC survey done in the calendar year (CY) preceding the implementing budget year for the project.

Table 4

FH New Construction Supporting Data*

	Documents Required						Certification
	DD Form 1377	DD Form 1378	DD Form 1379	DD Form 1390**	DD Form 1391**	DD Form 1523	
New Housing Construction							
Part I - Execution Program	X	X	X				X
Part II - Legislative Program	X	X	X	X	X	X	
Part III - Remaining Years	X	X	X				

*Bachelor Housing, AR 210-18 (Department of the Army, 14 January 1975).

**DD Forms 1390 and 1391 are prepared at the DA level.

FH programming characteristically includes a DA proposal submitted to the SOD for incorporation into a total military FH planning budget. Early FH planning is supported by the District, the IC, the MACOM, and OCE. The IC provides the statement of need and family housing inventories and surveys required for DA/DOD response. The MACOM integrates installation family housing requests and assigns priorities. OCE formulates the Family Housing Construction Program (FHCP) and presents it as the legislative program for Army Staff

¹⁸Family Housing Management, AR 210-50 (Department of the Army, 21 November 1972).

and OSA review and approval. The Army FHCP is integrated into the overall DOD Family Housing Program presented to the authorization and appropriation committees of Congress in a Congressional Data Book. If the requests are questioned, they are defended by OCE representatives.

An important part of FH planning is the Land-use Study (LUS) which considers property to be used and any impact on surrounding areas. Since statute requires the LUS to be made within the CY of construction, the final version of the study is developed after authorization and appropriation of the military FH bill by Congress. (Since the actual siting of an FH project is not fixed during the proposal stage, only gross estimates are possible at that time, sometimes resulting in allocation adjustments within the total budget.)

A new aspect in FH construction is the replacement of government design by turnkey operations for major projects in CONUS (see section A-4 of Appendix A). Turnkey, in this case, means that design and construction are under one contract, but does not imply absence of progress monitoring or contract management. Response to a turnkey Request for Proposal (RFP) is expensive, since substantive proposals and definitive prices are required. Only large organizations participate, and project submittal dates are spaced so that entry into one does not prevent participation in the next. All proposals with competitive prices are screened and scored by a National Evaluation Team (NET) constituted as shown in Table 5. The proposal and price can then be *renegotiated* and a new evaluation made. The procedure eventually results in a local District selection made on the basis of the lowest (price/proposal-score) ratio and the best interests of the government.

Table 5

National Evaluation Team Membership

National Permanent Members (5):	OCE representatives
Local Temporary Members (4):	Representation from each of the following:
	1. Using Installation
	2. Major Command
	3. Division
	4. District
Local Temporary Associate (Nonvoting) Members (2):	
	1. Real Estate Authority
	2. Project Manager (as District recorder)

Family Housing Projects, Modernization and Repair

Modernization and repair (MR) projects for existing family housing are approved and funded through OCE from designated appropriations. District procedures for MR projects include a feasibility (pre-design) study and a final design with appropriate fiscal and development/design reviews.

MCA Projects, Foreign

MCA projects on foreign soil are proposed by the Theater Commander and processed at the CE Division level for installation master planning and project programming. Planning, design, and construction contracting are performed in accordance with the regulations of the host country.

Information flow networks for the European Division are provided in Appendix B.

European Division (EUD)

The EUD provides MCA support to U.S. operations in Europe. An important example of EUD procedures occurs in Germany. The German government reviews all MCA projects at the proposal, design, and construction stages. Any U.S. construction costing more than 80,000 DM (\$28,000) must be approved as to its admissibility and evaluated as to where the design/construction responsibility will lie. The German government decides whether government engineering personnel will perform functions associated with the District in CONUS MCA procedures or if all activity other than environmental impact review will be left to the Division (Appendix B).

The EUD now provides the MCA support to Army, Air Force, and Navy installations in Italy, Greece, and Turkey which was formerly (FY75) provided by the Mediterranean Division (MD). Italy is an example of former MD procedures. The Italian government reviews U.S. Army military construction plans through a "Mixed Commission" (IMC). The IMC board reviews building plans for compatibility with local structural codes, to insure that Italian materials and machinery are used (as required by agreement), and to determine the long-term usefulness of the structure. A key criterion is whether the proposed facility designs will be useful to the Italians after the American departure (Appendix B).

Army Reserve Center (ARC) Construction Projects

Army Reserve Center (ARC) programming, design, and construction use the same documentation and communication forms as MCA-funded construction, but in different procedural flow patterns (Appendix C).

ARC projects are formulated between command channels, the Major Command (FORSCOM), and the Office of the Chief of Army Reserve (OCAR) from reserve unit requests and a Long-Range (10-year) ARC Planning Program. ARC construction funding for a budget year is an inclusive appropriation, permitting the Chief of AR to delegate or restrict funds to any particular project. This flexibility simplifies responding to planning changes or contingencies (within OSD limits).

Support to ARC projects providing for joint use by other military reserves depends on location and which military construction agency may most feasibly direct the project. When CE support is used, the project (usually minor construction) is handled by the District with relative independence.

For both joint- and single-use ARC, user design reviews are implemented at the concept and preliminary design levels, and courtesy contract award notifications are provided. No budget or technical supervision is applied unless conditions change or other problems arise. If 2 years pass between fund appropriation and construction-start, the Congressional A&A committees are notified when projects require funding changes. Construction contracting then proceeds after a "hold" of 30 days.

Air Force Construction Projects

Air Force (USAF) military construction is built to HQUSAF/PRE and OCE specifications, under the supervision of the Division Engineer, and in consultation with the Air Force Resident Civil Engineer (AFRCE).

The information flow within the CE for USAF projects is similar to MCA-funded projects except for the AFRCE interface. The AFRCE has the option to consult with the Division Engineer, sit on the AE Selection Board, review preliminary designs, and inspect construction progress. He is responsible for coordination of user design reviews and the "Letter of Authorization" for construction contracting.*

No preliminary study directives are issued by OCE on USAF projects; only concept or early preliminary (CD or EPD), preliminary (PD), and final designs (FD) are performed, with an extensive PDR supported by all

*AFRCE functions, responsibilities, and authority are explained in *Air Force Regional Civil Engineers*, AFR 88-18 (Department of the Air Force, 6 March 1970), and summarized in *Construction Management*, AFR 89-1 (Department of the Air Force, 21 January 1970), Paragraph 4-4.

interested USAF Commands. As in MCA procedures, District/Division support to USAF construction may vary. When medical facilities are to be built on USAF bases, the AFRCE monitors the AE through completion of the concept design. After CD, exclusive direction returns to the District. All other aspects of USAF construction projects are similar to MCA-funded procedures.

NASA Construction

NASA construction projects cannot currently be represented by one procedural diagram. In the past, NASA programming procedures were often determined by the local director on a need basis. A changed funding situation has now resulted in close fiscal control by NASA Headquarters (NASA HQ).

The CE support procedure at the Los Angeles District is sufficiently standardized to permit development of the information flow network shown in Appendix E. The NASA Field Office (NASA FO), under close monitoring by NASA HQ, supports a three-phase design effort (first FY funding), followed by a contracting procedure (next FY funding) adapted to NASA policies. The latter includes commercial-style advertising and a contractual stipulation that the CE does all quality control inspections (no contractor quality control).

6 SUMMARY AND CONCLUSIONS

Summary

Actual MCA programming and planning procedures were obtained from District/Division interviews and correlated with known regulations to develop functional flows on which information flow could be identified. The data obtained have been sufficiently detailed to permit interpretation of three levels of CE procedural detail in information flow networks: 1) **performance area** (eight example networks), 2) **basic function** (17 example networks), and 3) **detailed function** (five example networks). This analytical approach covers seven types of construction supported by CE military construction services.

The major construction information flow networks of Appendix A reflect a characteristic District task. Shown are an overall performance area diagram and 15 basic function flows, representing each of the significant block functions in the top flow.* In addition, two

*Basic function flows for Blocks 14 and 17 are not considered significant and were omitted.

functions (AE and construction contracting) are taken to the detailed function level. This presentation satisfies the analytical goals of this report, and allows for future expansion to any level of detail desired.

Conclusions

The method of presentation developed in this report provides a dynamic representation of Corps procedures at graded levels of detail, permitting convenient studying and utilization by researchers of varying interest levels.

LIST OF SYMBOLS

A: Army
A & A: Authorization and appropriation
ADP (E): Automated data processing (equipment)
AE or A/E: Architect-engineer
AEADS: Automated Engineering and Architectural Design System
AEC: Atomic Energy Commission (now Nuclear Regulatory Commission)
AFPB: Air Force Project Book
AFRCE: Air Force Resident Civil Engineer
AMC: Army Materiel Command (now Army Development and Readiness Command)
AR: Army Regulation
AR (C): Army Reserve (Centers)
ASA (I&L): Assistant Secretary of the Army (Installations and Logistics)
ASD: Assistant Secretary of Defense
ASIP: Army Stationing and Installation Plan
ASPR: Armed Services Procurement Regulations
Acq.: Acquisition
Awd: Award
B: Budget
BC: Budget Control
BD: Board
BH: Bachelor Housing
BIM: Basic Information Map
BiS: Building Information Schedule
BLS: Bureau of Labor Statistics
BP: MC Bid Package
Br: Branch
BRC: Budget Review Committee, DA staff level
BY: Budget year
C: Construction
C or Cmd: Command
CAEADS: Computer-Aided Engineering and Architectural Design System
CBD: Commerce Business Daily (government publication)

CD (R): Concept Design (Review)
 CE: Corps of Engineers
 CEOP: Corps of Engineers Operations Plan
 CFR: Code of Federal Regulations
 Ch: Channels
 CK: Construction contract
 CLAW: Contract Letter Award
 CO: Contracting Officer
 COA: Comptroller of the Army
 COEMIS: CE Management Information System
 CONUS: Continental United States
 CP: Construction project
 CPEF: Cost plus fixed fee contract
 CQC: Contractor quality control
 CRRC: Construction Requirements Review Committee,
 DA Staff Level
 CWE: Current Working Estimate
 CY: Calendar year
 D: Design
 DA: Department of the Army
 DB or S: Design Branch or Section
 DCAA: Defense Contract Audit Agency
 DCS: Deputy Chief of Staff
 DDESB: Explosives Safety Board
 DE: District Engineer
 DE (CO): DE acting as Contracting Officer
 D & F: Determination of Findings Form (AE selection)
 DI: Design Instructions (Air Force)
 Dist: District
 Div: Division
 Div E: Division Engineer
 DOD: Department of Defense
 DPC: Data Processing Center
 DPI: Data Processing Installation
 Dwgs: Drawings
 E or Engr: Engineer(ing)
 E or Env: Environmental
 E or Est: Estimate
 EAM: Electric Accounting Machine (cards)
 ED: Engr Division
 EIRS: Engineering Improvement Recommendations
 System
 EP: Engineering Pamphlet
 ER: Engineering Regulation (DA)
 EUD: European Division
 Eval: Evaluation
 F: Facility
 FAS: Financial Accounting Subsystem (COEMIS)
 FE or FAC/E: Facilities Engineer
 FD (R): Final Design (Review)
 FF: Findings of fact
 FH: Family housing
 FH (C) P: Family Housing (Construction) Program
 FHMA: FH Management Agency
 FMP: Force and Mission Planning
 FORSCOM: U.S. Army Forces Command
 FPR: Federal Procurement Regulations
 FY: Fiscal year
 FYDP: Five Year Defense Plan
 G or Gov: Government
 GAO: General Accounting Office
 GB: Green Book
 GE: Government Estimate
 GFE: Government-furnished equipment
 GSA: General Services Administration
 H: Housing
 HQ (DA)-(USAF): Headquarters (Department of the
 Army) (Air Force)
 HND: Huntsville Division
 I: Installation
 IC: Installation Commander
 ID: Identification
 IFB: Information for Bidder
 IFS: Integrated Facilities System (COEMIS)
 IMC: Italian Mixed Commission
 IMP: Installation Management and Planning
 IPAR: Individual Procurement Action Report
 IPB: Installation Planning Board
 IRCP: Intermediate-Range Construction Program
 Inv: Inventory
 JMRC: Joint Military Research Centers
 K: Contract or thousand (\$)
 L: Land, logistics, or letter
 LOG: Logistics
 LRCP: Long-Range Construction Program (Master Plan)
 LU: Land use
 LUS: Land-Use Study
 M: Military
 MACOM, Maj C or MC: Major Command(er)
 MCA: Military Construction (Army)
 MD: Mediterranean Division
 MIDAS: Management Information and Decision Anal-
 ysis System
 MISO: Management Information System Office
 MP: Master Plan(ning)
 MRD: Missouri River Division
 MRK: Kansas City District (MRD)
 MRO: Omaha District (MRD)
 MRP: Military real property
 NAB: Baltimore District (NAD)
 NAD: North Atlantic Division
 NAN: New York District (NAD)
 NAO: Norfolk District (NAD)
 NASA: National Aeronautics and Space Administration
 NATO: North Atlantic Treaty Organization
 Neg: Negotiator or negotiation

NET: National Evaluation Team (FH)	RF (I): Real Property (Inventory)
No.: Number	RF (P) (Q): Request for (Proposal) (Quote)
NTP: Notice to Proceed	Rx: Receive
OASD: Office of the Assistant Secretary of Defense	S: Study or system
OCAR: Office of the Chief of Army Reserve	SAD: South Atlantic Division
OCE: Office of the Chief of Engineers	SAM: Mobile District (SAD)
OCR: Optical code reader	SAS: Savannah District (SAD)
OMB: Office of Management and Budget	SBA: Small Business Authority/Administration
OSD: Office of the Secretary of Defense	SOD: Secretary of Defense
OTSG: Office of the Surgeon General	SOW: Statement of work
P: Project	Sp: Special
PA: Public announcement	SPD: South Pacific Division
PCDP: Preconcept Control Data Package	SPK: Sacramento District (SPD)
PDB-1: Project Development Brochure—Part 1	SPL: Los Angeles District (SPD)
PD (R): Preliminary Design (Review)	SRCP: Short-Range Construction Program
PM or PE: Project Manager or Project Engineer	SWD: Southwest Division
PO: Printout	SWF: Fort Worth District (SWD)
PR: Progress Report	TK: Turnkey contract
R: Report	TRADOC: U.S. Army Training and Doctrine Command
RA/PMS: Resource Allocation/Project-Management (Automated) System	TSA: Troop Support Agency
RDTE: Research, development, test and evaluation	Tx: Transmitted
RE: Real estate	U: Utilities
Rec: Record	UMC: Urgent Minor Construction
Rev: Review	U.S.C.: United States Code

REFERENCES

- Air Force Regional Civil Engineers*, AFR 88-18 (Department of the Air Force, 6 March 1970).
- The Army Physical Security Program*, AR 190-13 (Department of the Army, 23 August 1974).
- Bachelor Housing*, AR 210-18 (Department of the Army, 14 January 1975).
- Construction Criteria Manual*, DOD 4270.1M (Department of Defense, 1972).
- Construction Management*, AFR 89-1 (Department of the Air Force, 21 January 1970).
- Coordination With Armed Services Explosives Safety Board*, AR 385-60 (Department of the Army, 20 December 1971).
- Divisions and Districts*, ER 10-1-3 (Department of the Army, 1 May 1968).
- Environmental Pollution Abatement*, AR 11-21 (Department of the Army, 3 November 1967).
- Environmental Protection and Enhancement*, AR 200-1 (Department of the Army, 14 November 1975).
- Family Housing Management*, AR 210-50 (Department of the Army, 21 November 1972).
- General Provisions for Military Construction*, AR 415-10 (Department of the Army, 15 March 1972).
- Installation Expansion Capability Guide*, TB ENG 354 (Department of the Army, 15 March 1976).
- Management of Resources—Commercial and Industrial-Type Functions*, AR 235-5 (Department of the Army, 6 November 1974).
- Master Planning for Permanent Army Installations*, AR 210-20 (Department of the Army, 1 January 1973).
- MCA Program Development*, AR 415-15 (Department of the Army, 8 May 1969).
- Medical Facilities Design - Army*, TM 5-838-2 (Department of the Army, 6 April 1970).
- Military Construction Progress Reporting*, ER 415-345-43 (Department of the Army, 31 March 1972).
- Minor Construction*, AR 415-35 (Department of the Army, 16 July 1970).
- Planning and Project Authorization—Military Projects*, ER 405-345-100 (Department of the Army, 26 March 1973).
- Poskus, U.R., *Executive Summary for the Automated Military Construction Progress Reporting System (AMPRS)*, Technical Report P-50 (Construction Engineering Research Laboratory [CERL], 1975).
- Project Development Brochures—Part I*, TM 5-800-3 (Department of the Army, 15 May 1974).
- Project Development and Design Approval*, AR 415-20 (Department of the Army, 28 March 1974).
- U.S. Army Forests Command*, AR 10-42 (Department of the Army, 15 April 1975).
- U.S. Army Health Services Command*, AR 10-43 (Department of the Army, 5 February 1975).
- U.S. Army Training and Doctrine Command*, AR 10-41 (Department of the Army, 27 June 1973).

APPENDIX A: MCA CONUS PROJECT PROCEDURES

Section	Page
A-1 MCA Minor Construction Project Procedures	43
A-2 MCA Major Construction Project Procedures	47
A-3 Performance Practices of Selected Districts	82
A-4 Family Housing Construction and Improvement Practices	91

A-1 MCA Minor Construction Project Procedures

A-1
 PERFORMANCE AREAS MCA, MINOR CONSTRU

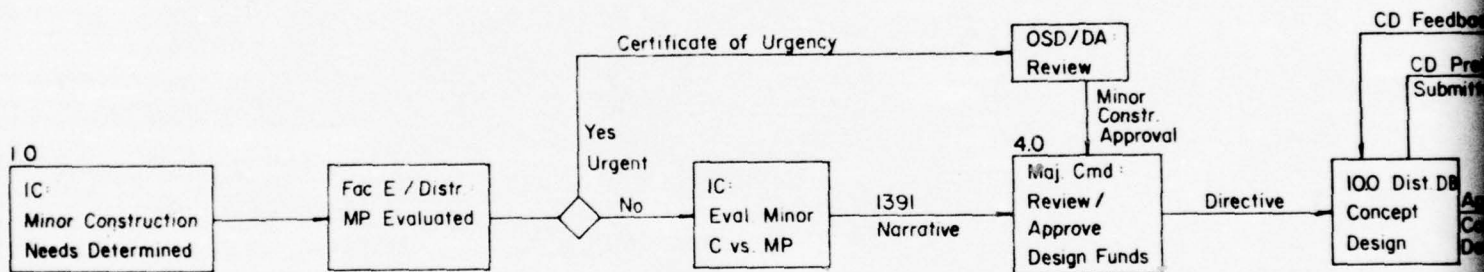

AS MCA, MINOR CONSTRUCTION

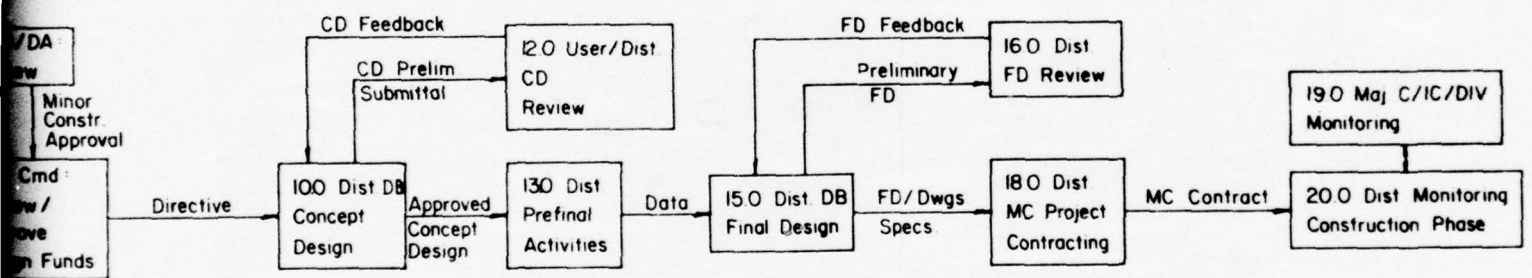

2

A-2 MCA Major Construction Project Procedures

A-2
PERFORMANCE AREAS
MC PROJECTS, MAJOR CONSTRUCTION

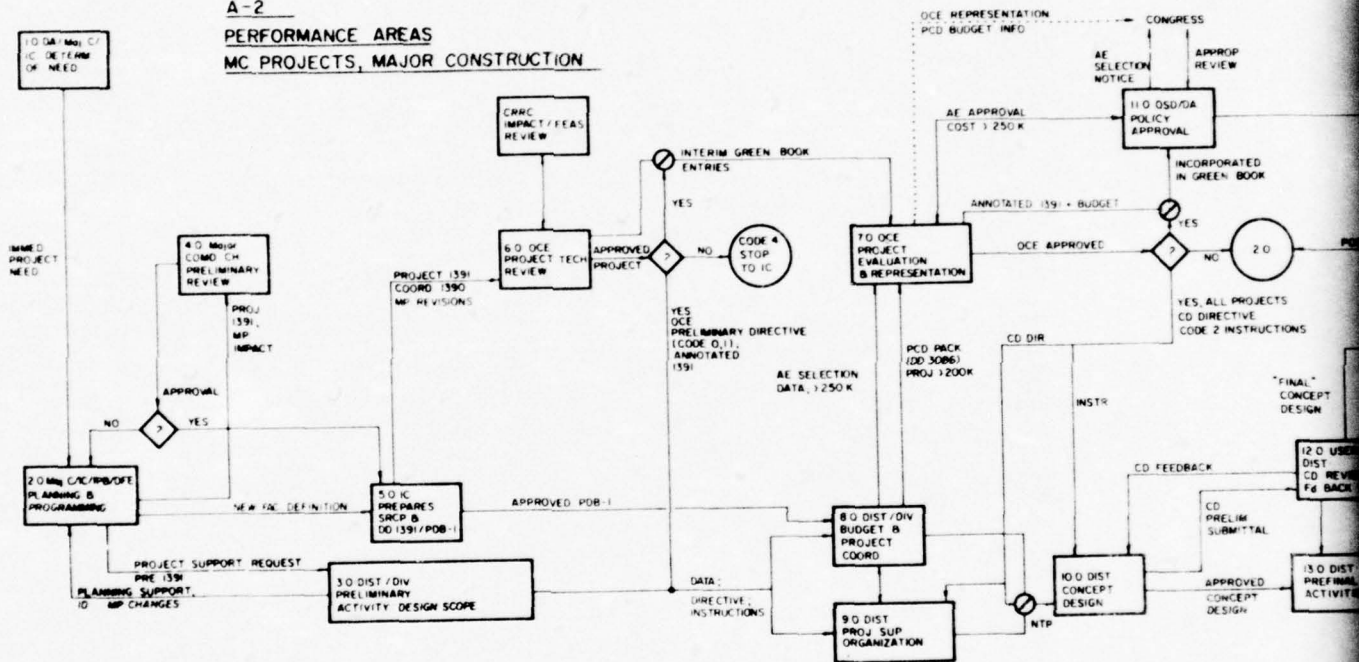

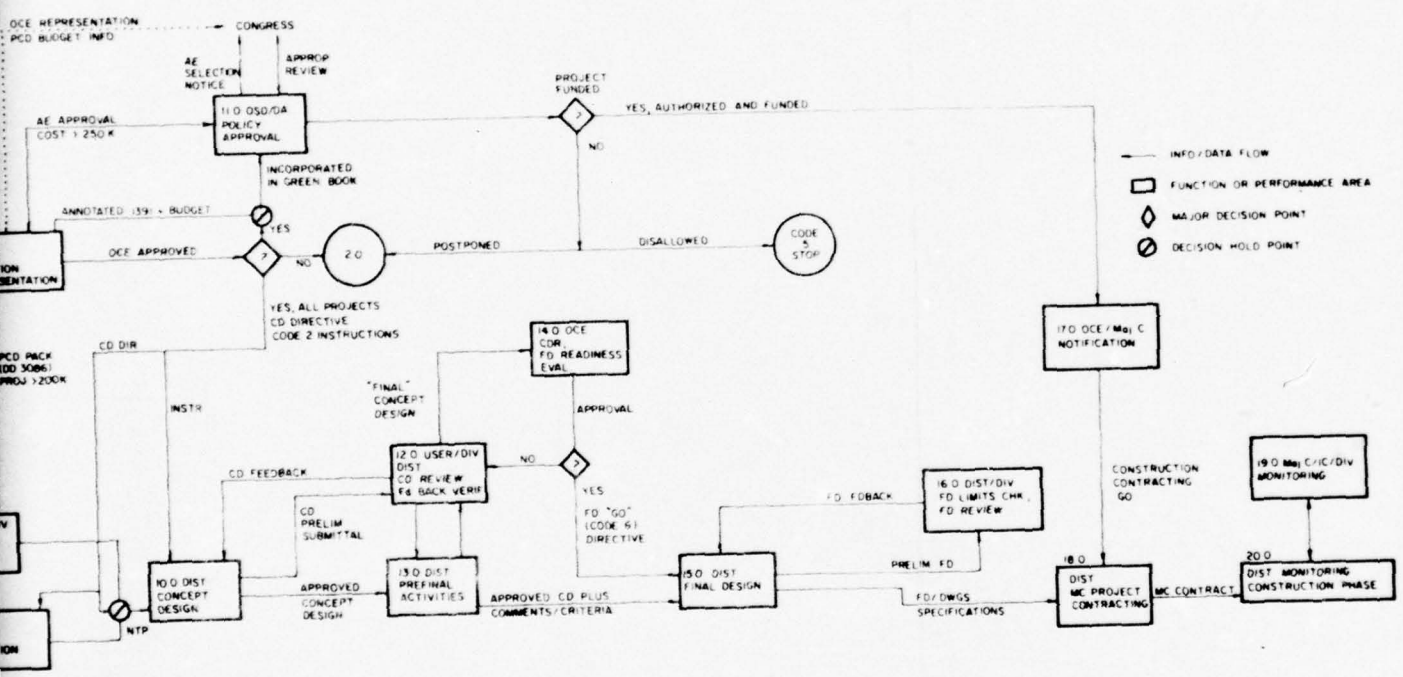

2

A-2 1.0 DETERMINATION OF NEED

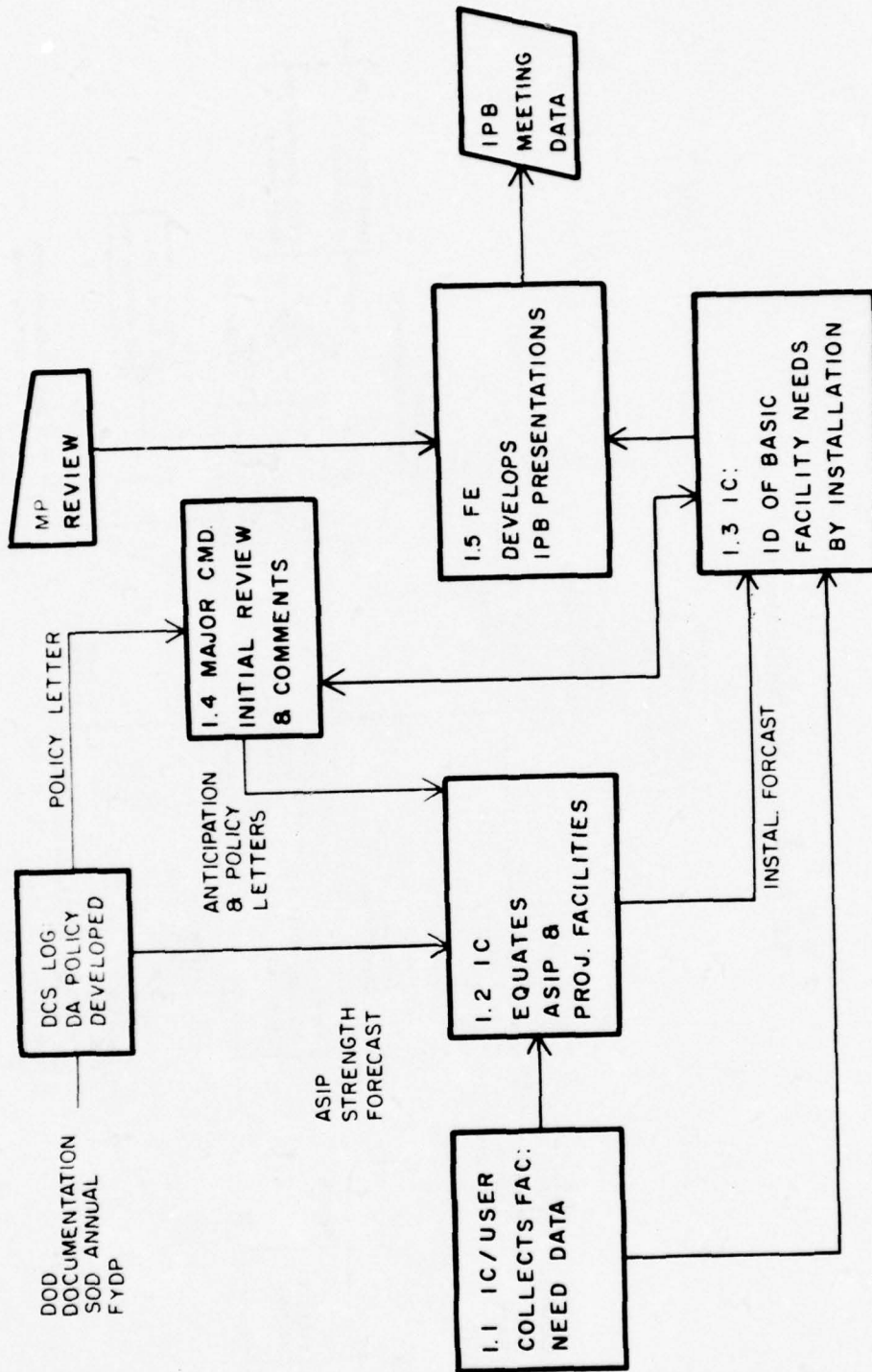

A-2
2.0 PLANNING AND PROGRAMMING

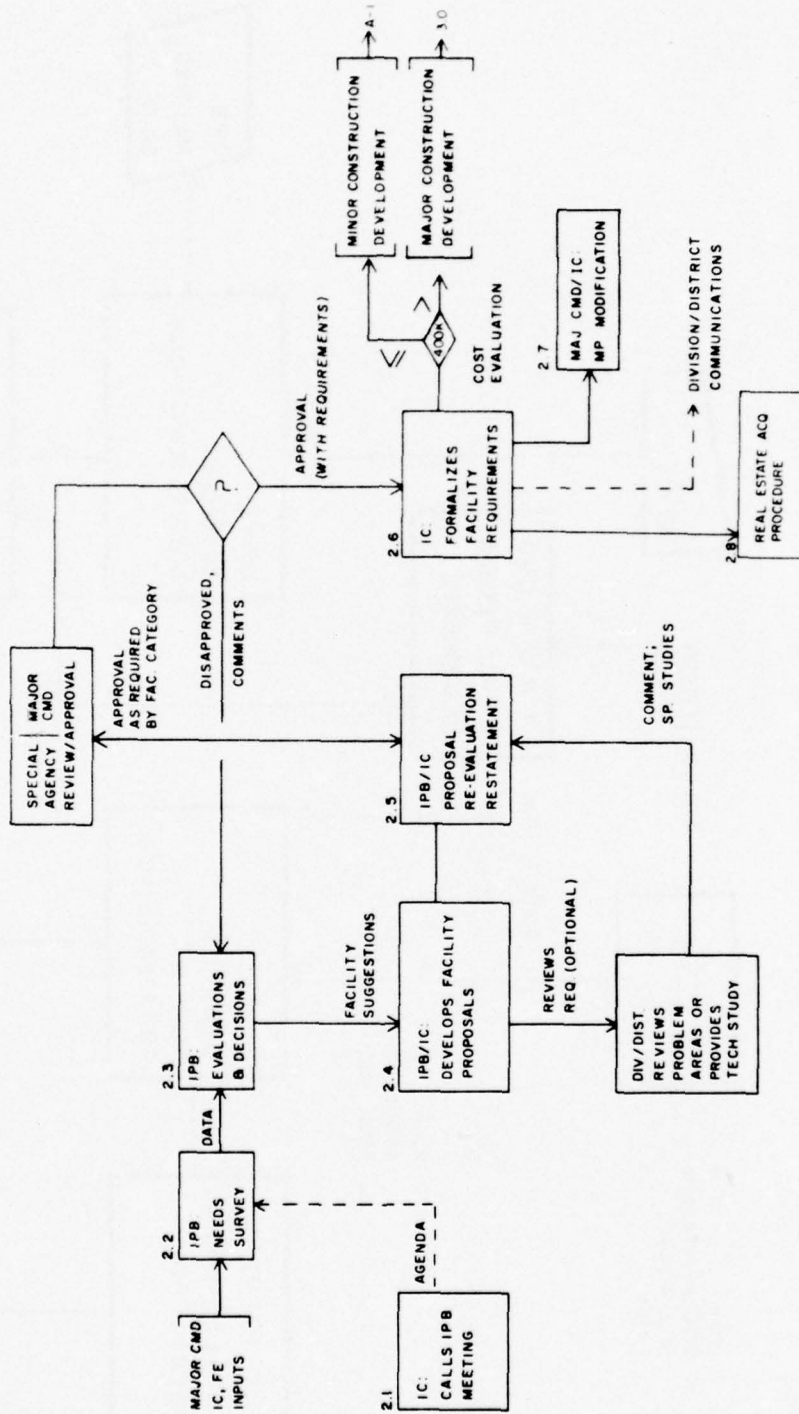

A-2
3.0 DISTRICT PRELIMINARY ACTIVITIES

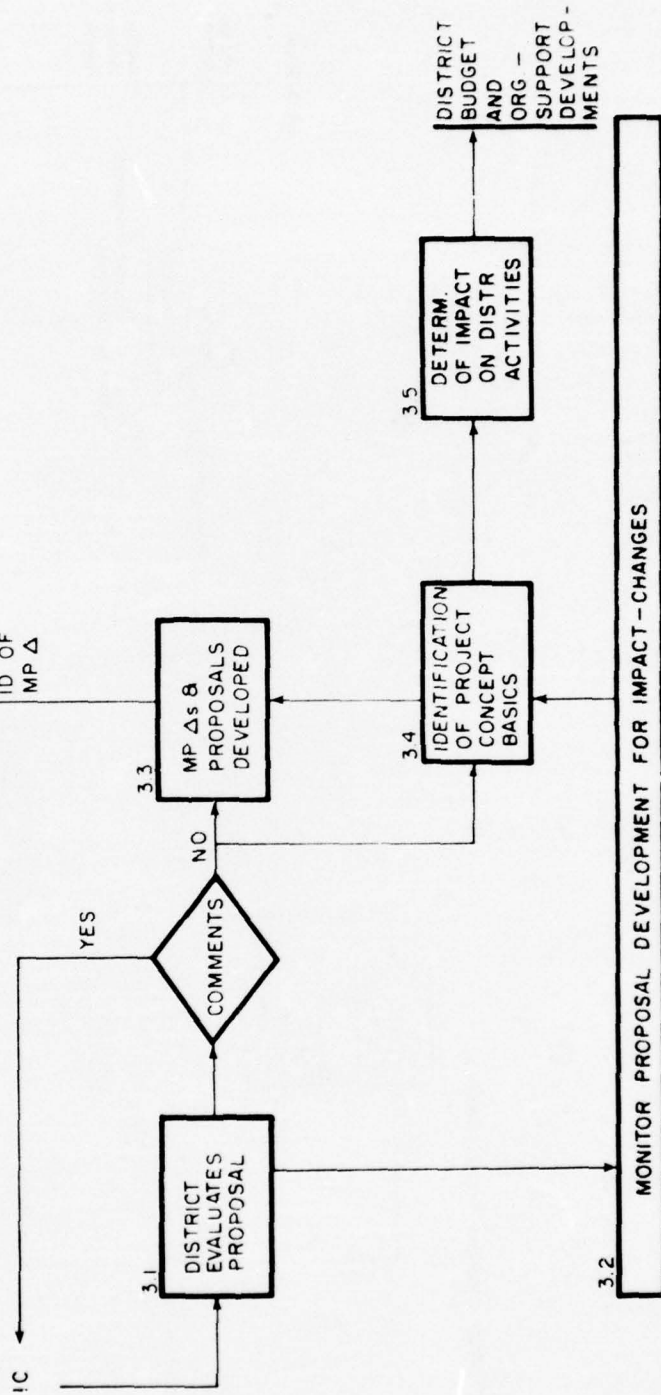

A-2
40 Major Command Review (TRADOC)

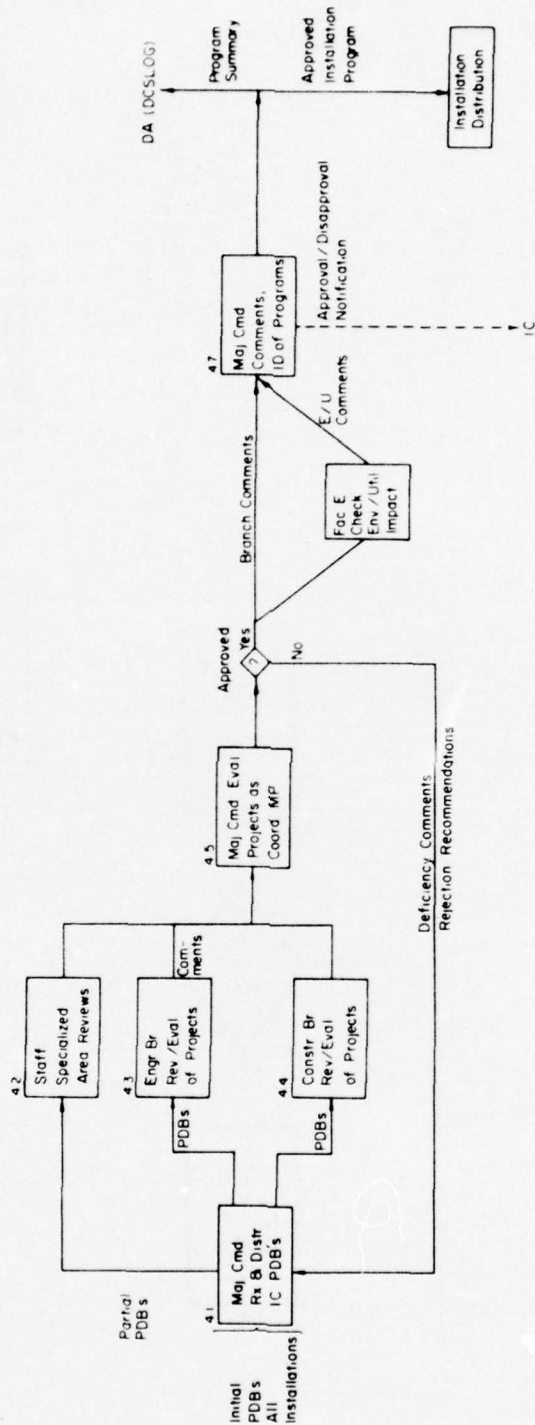

A-2
 4.0 MAJOR COMMAND REVIEW (FORSCOM)

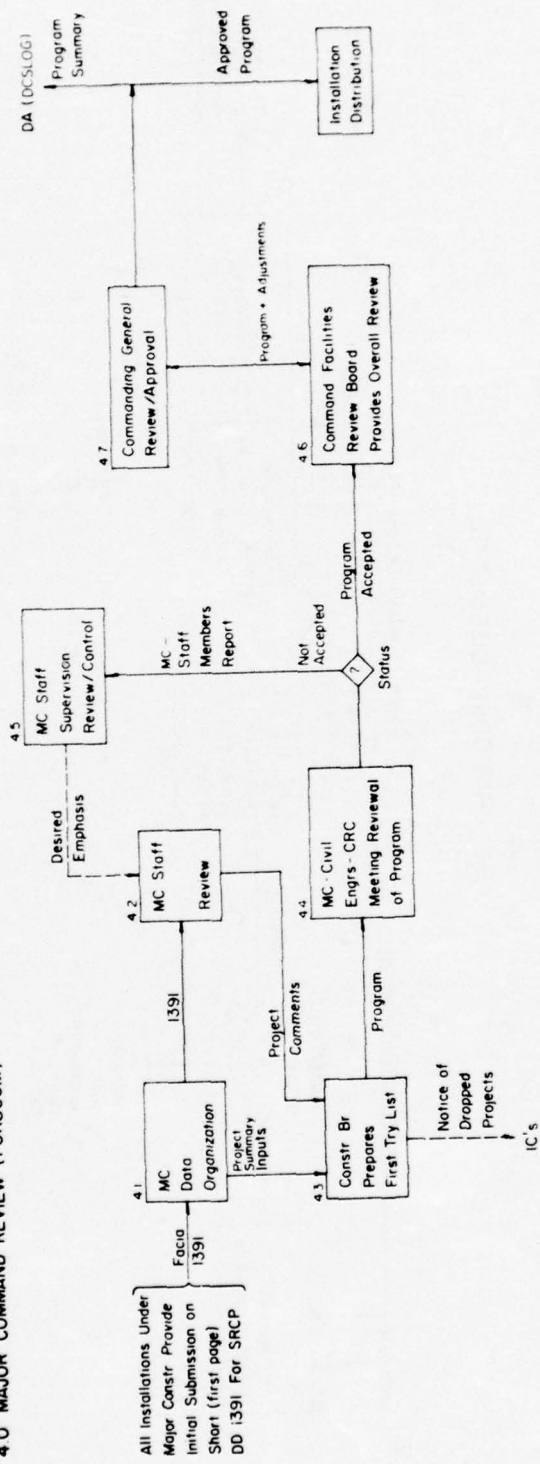

A-2
5.0 PROPOSAL SUBMITTAL

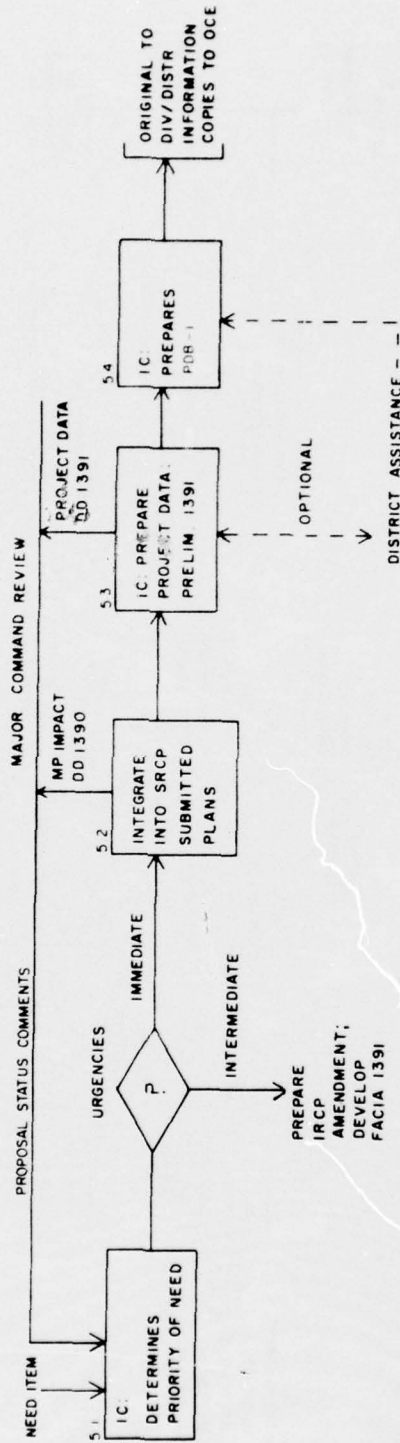

A-2
6.0 OCE PROJECT TECHNICAL REVIEW

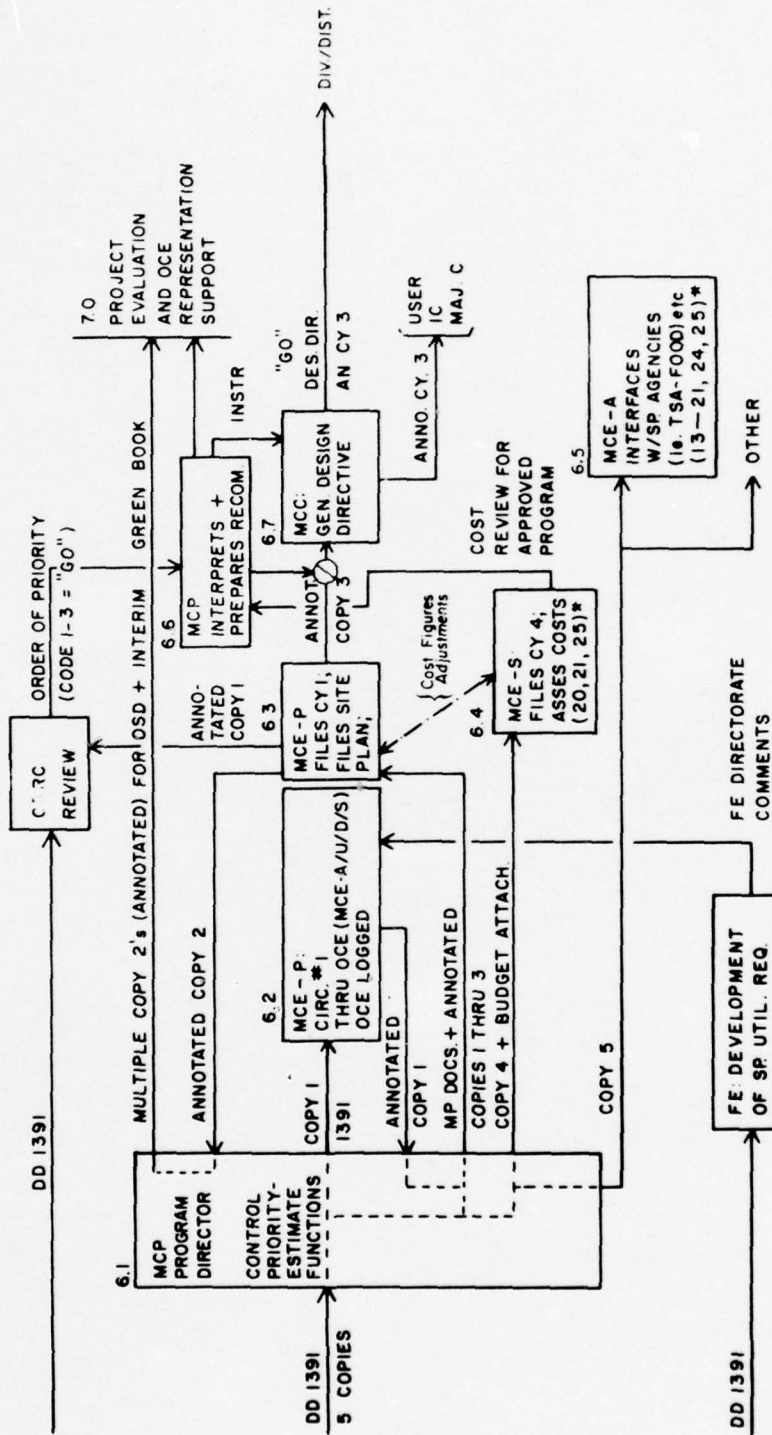

A-2

7.0 OCE PROJECT EVALUATION AND PROGRAM REPRESENTATION

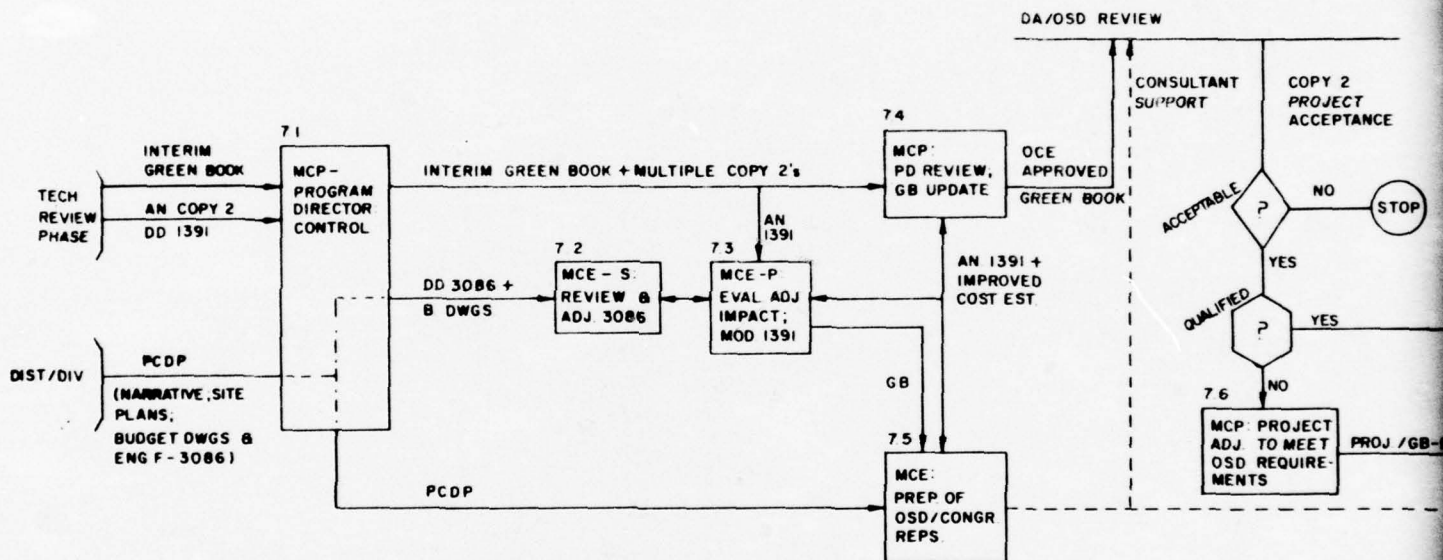

DA/OSD REVIEW

DA/OSD/CONGRESSIONAL REVIEW

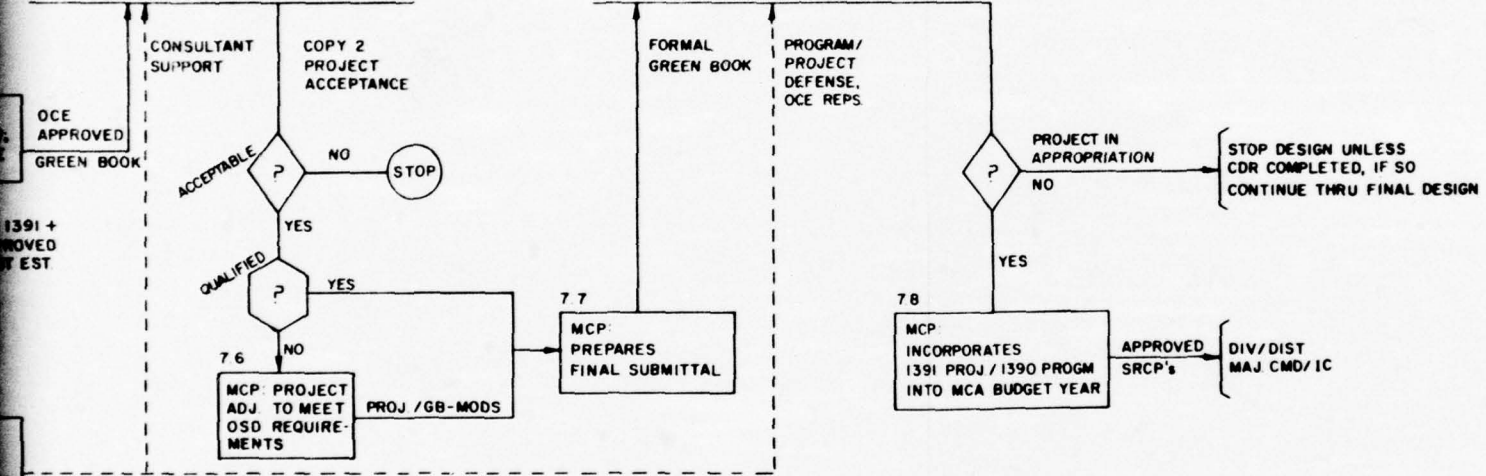

2

A-2
8.0 BUDGET PREPARATION AND REVIEW

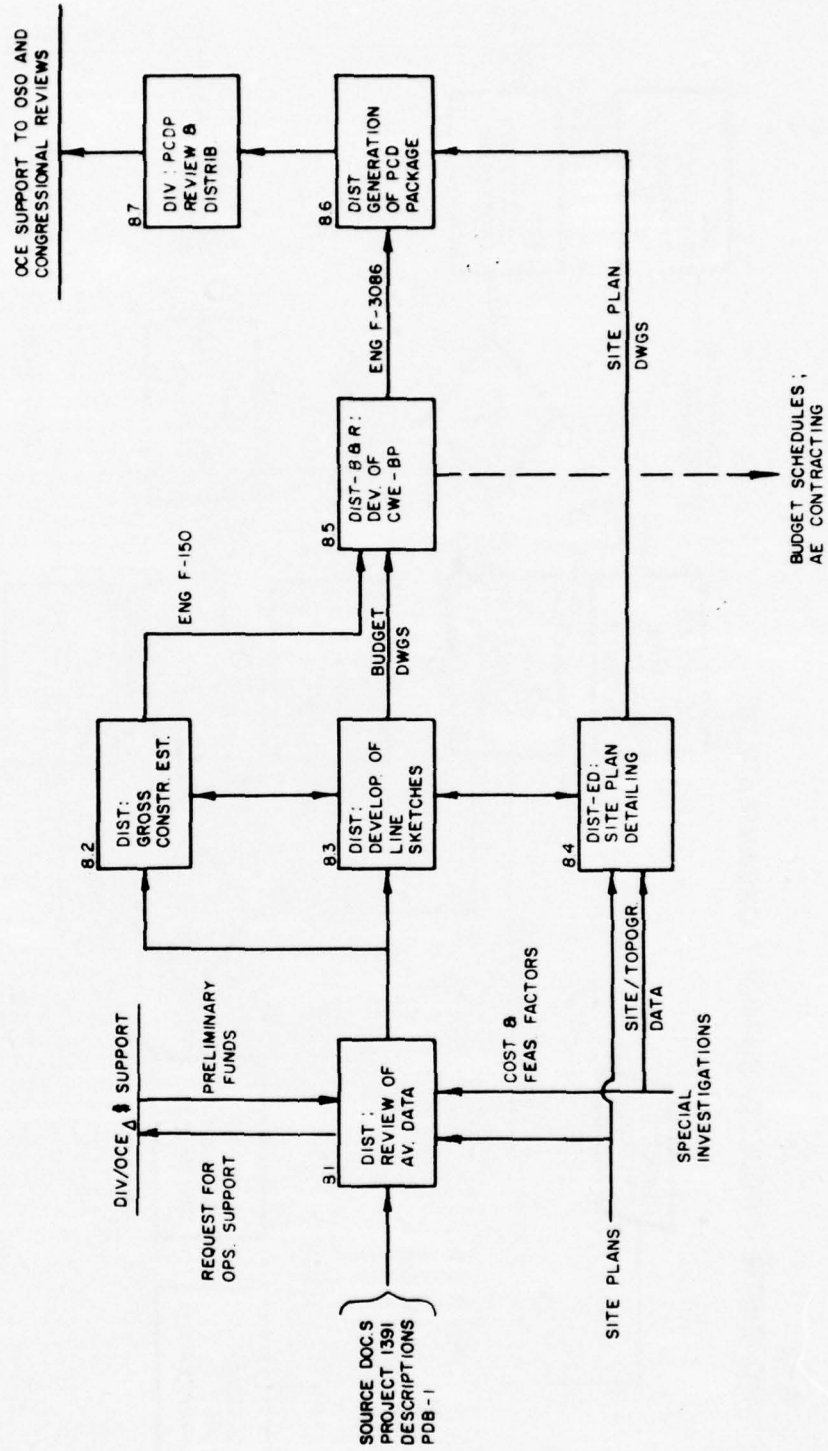

A-2
 9.0 DISTR. PROJECT-SUPPORT ORGANIZATION

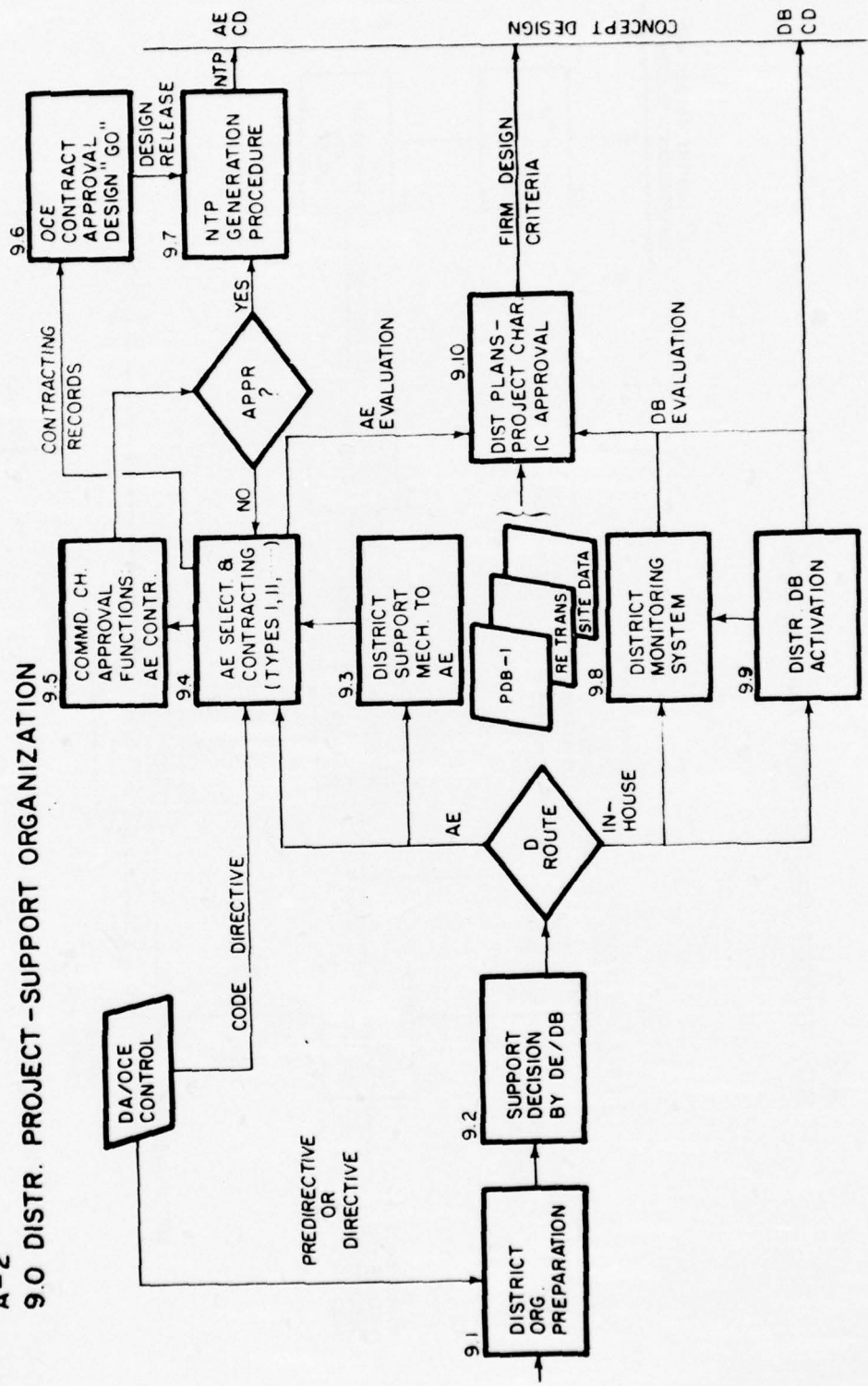

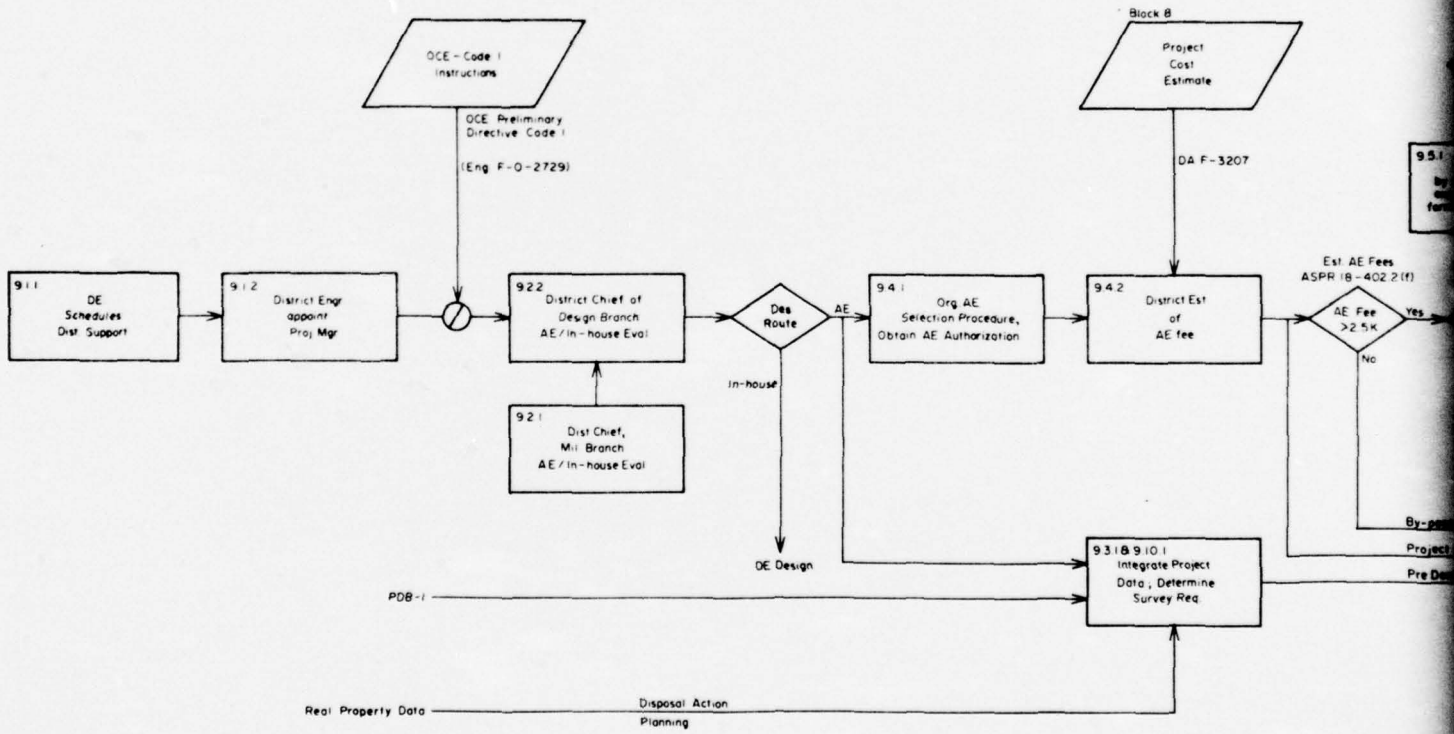

A-2
 9.1.1 to 9.4.7 DISTRICT ORGANIZATION SUPPORT AND AE PRESELECTION

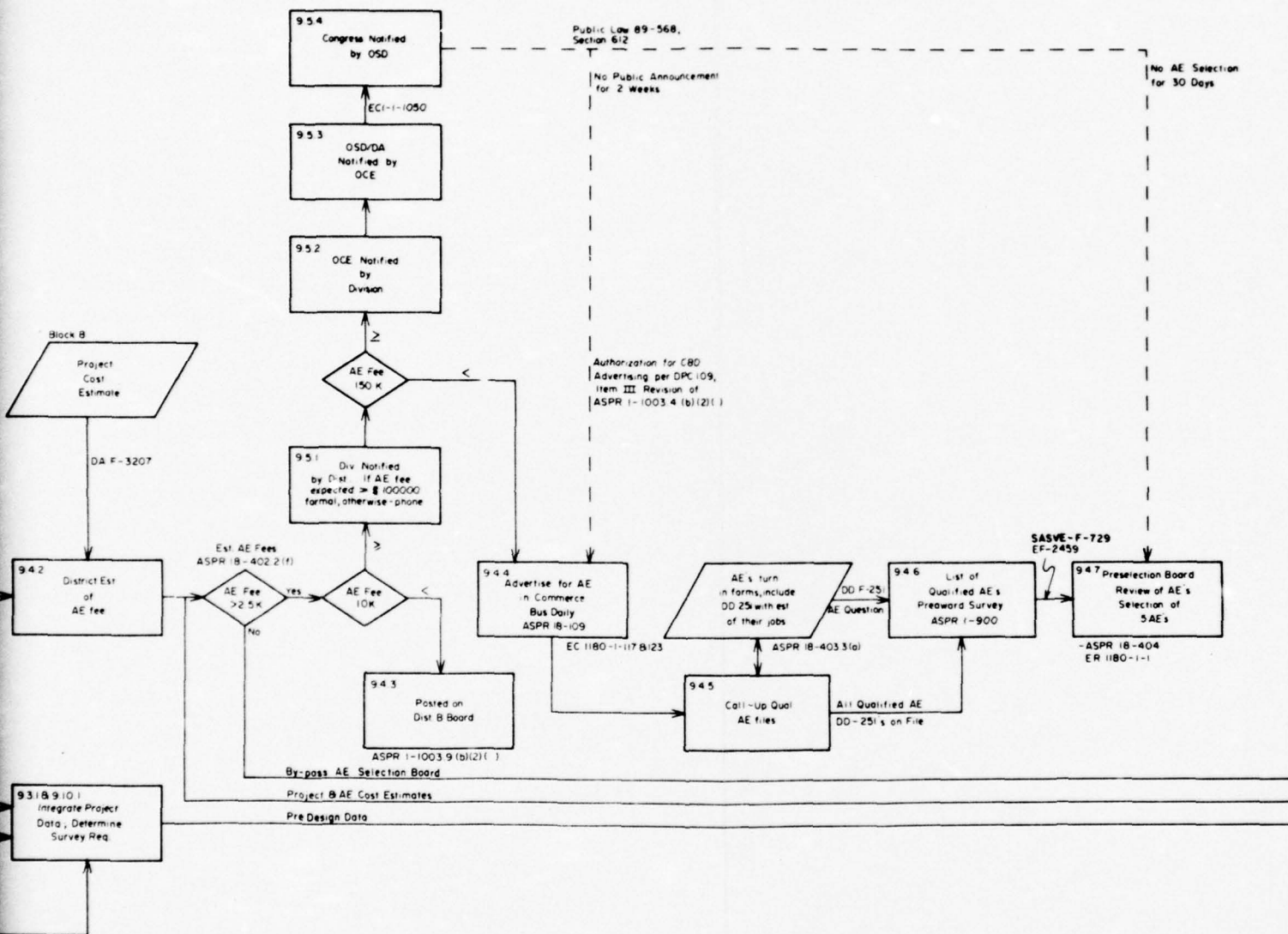

2

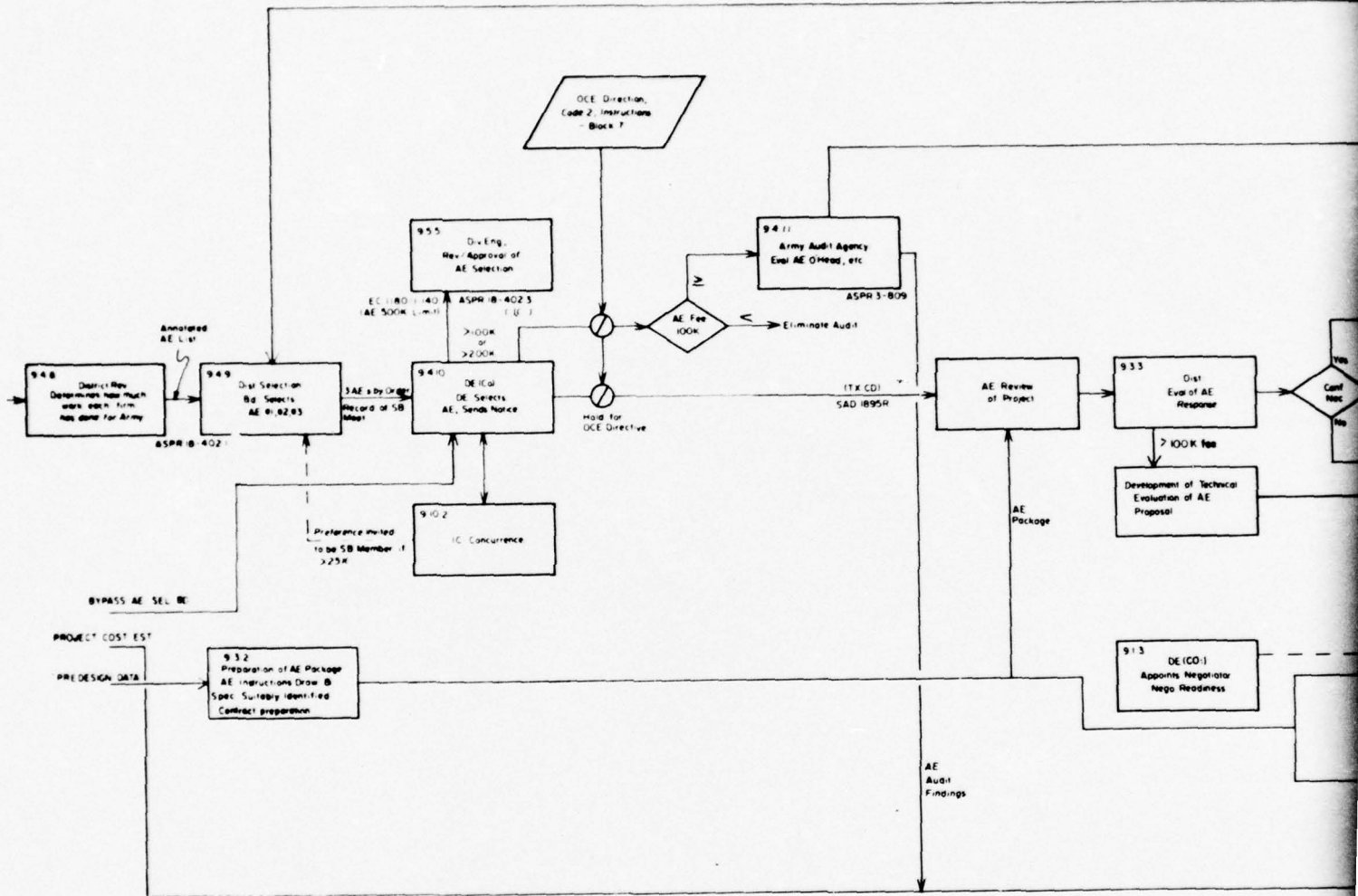

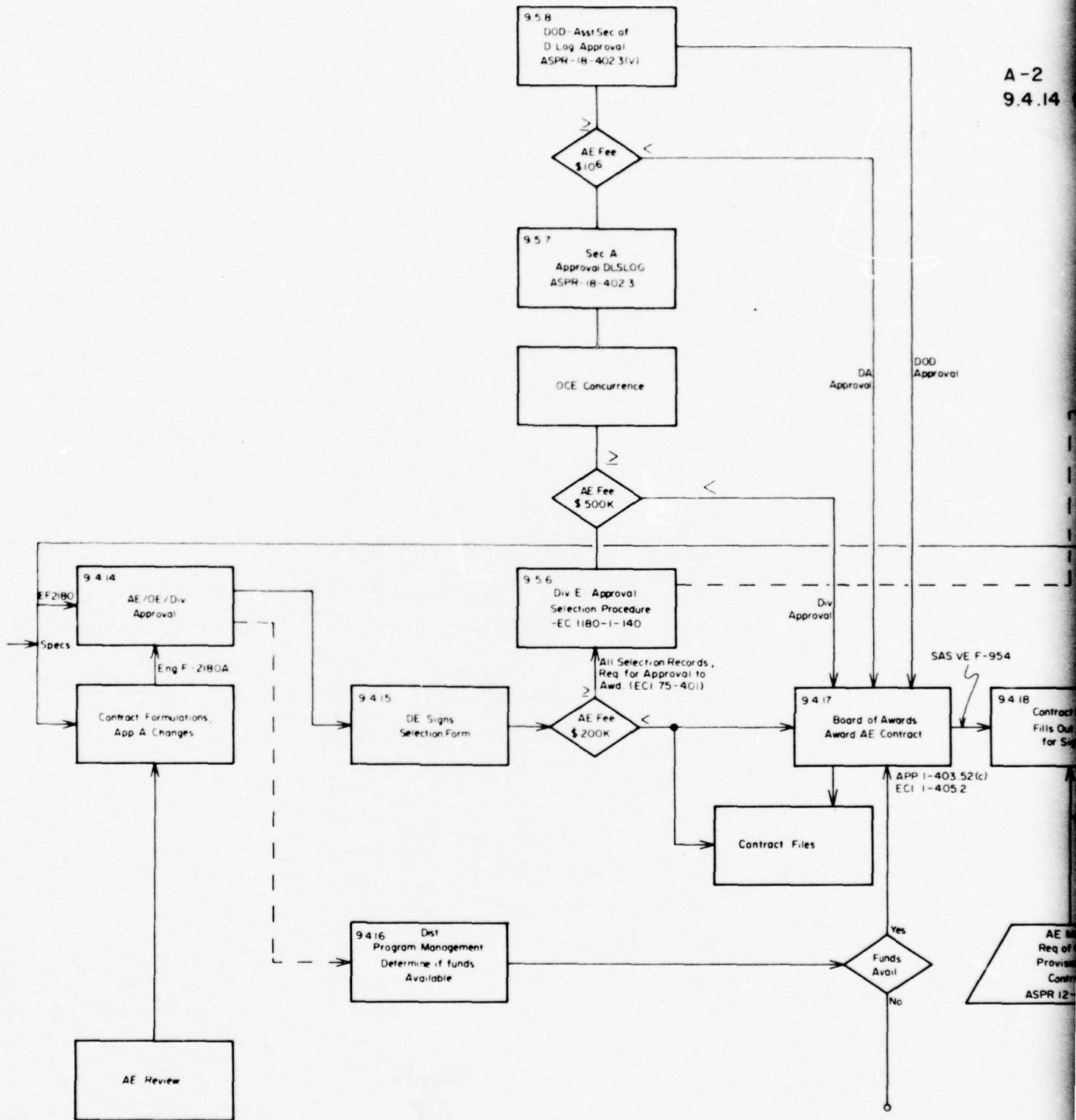

PRECEDING PAGE BLANK-NOT FILMED

A-2

9.4.14 to 9.7.4 AE CONTRACTING AND DESIGN NTP

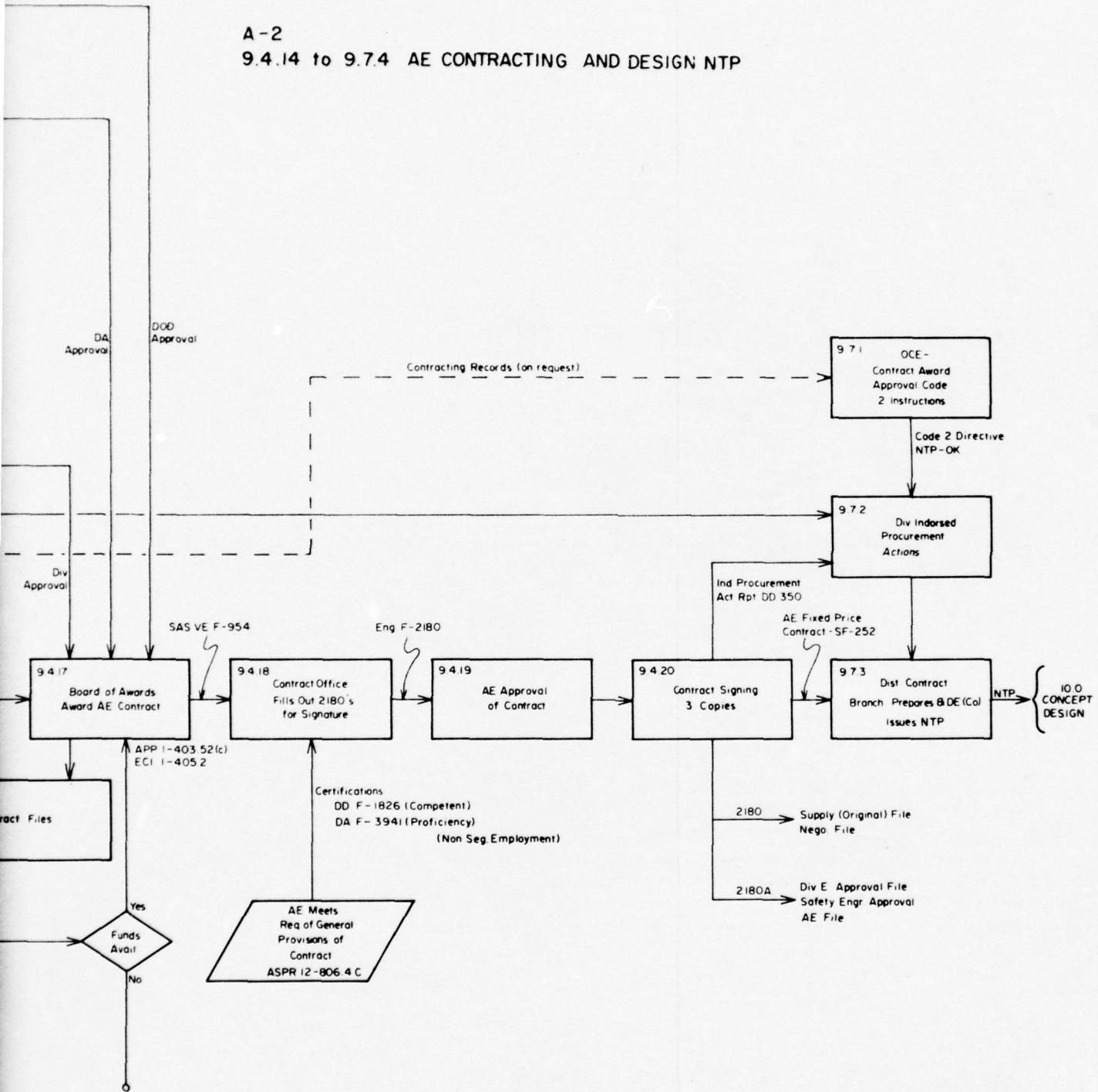

2

A-2
 11.0 OSD/DA POLICY APPROVAL

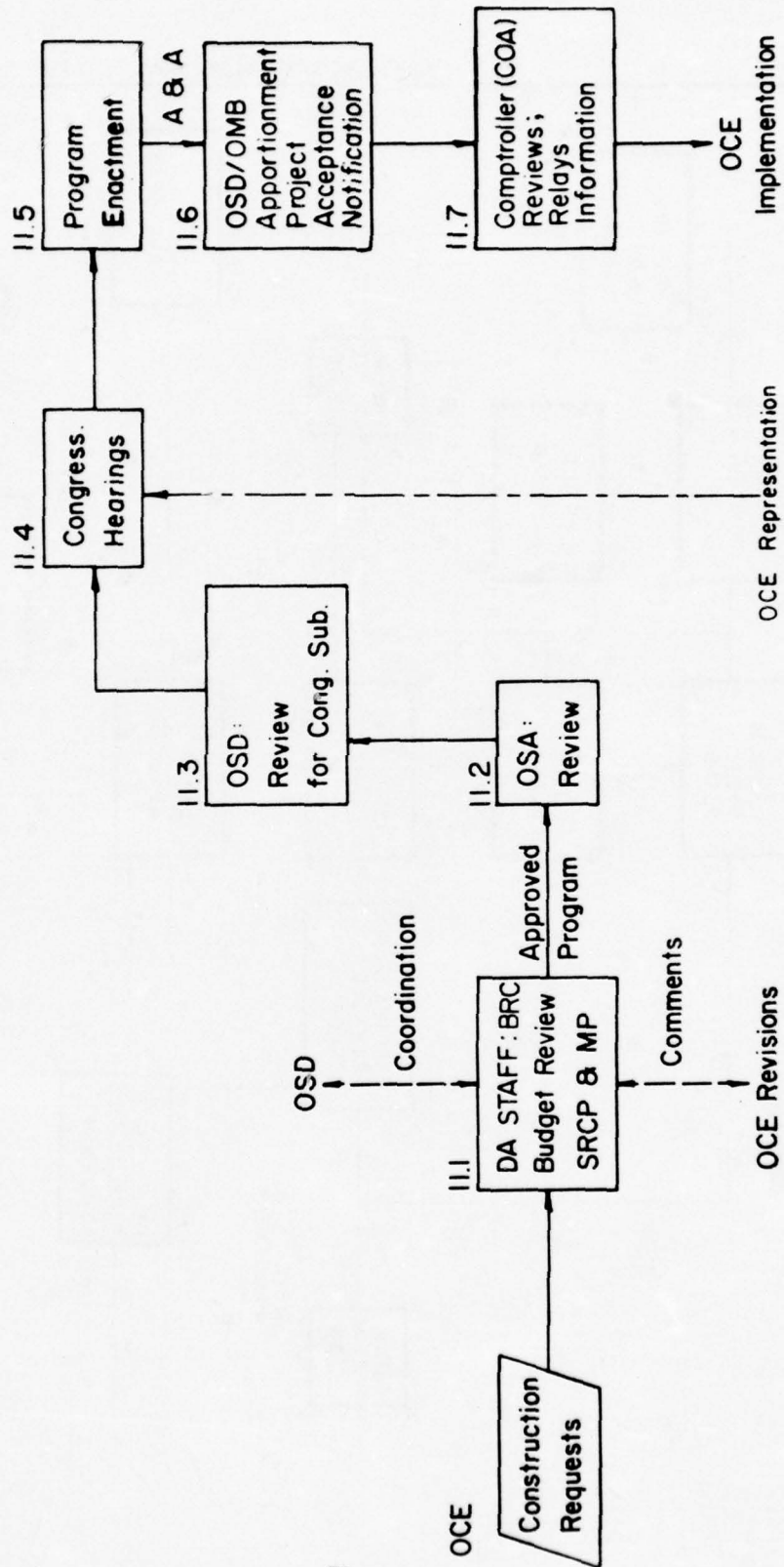

A-2
 I2.0 CONCEPT DESIGN REVIEW

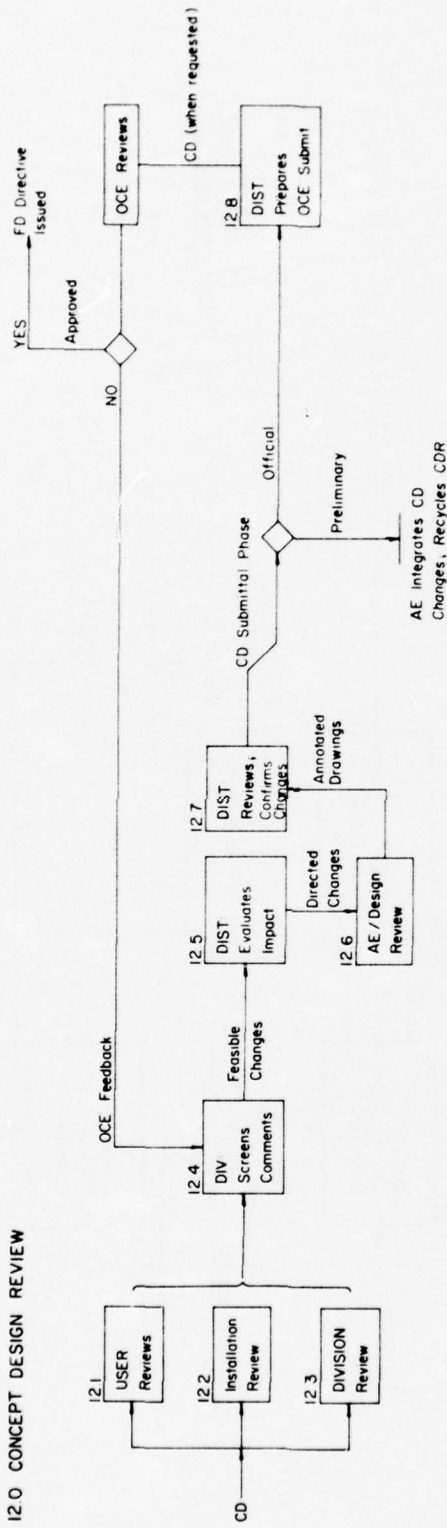

A-2
13 PREFINAL ACTIVITIES

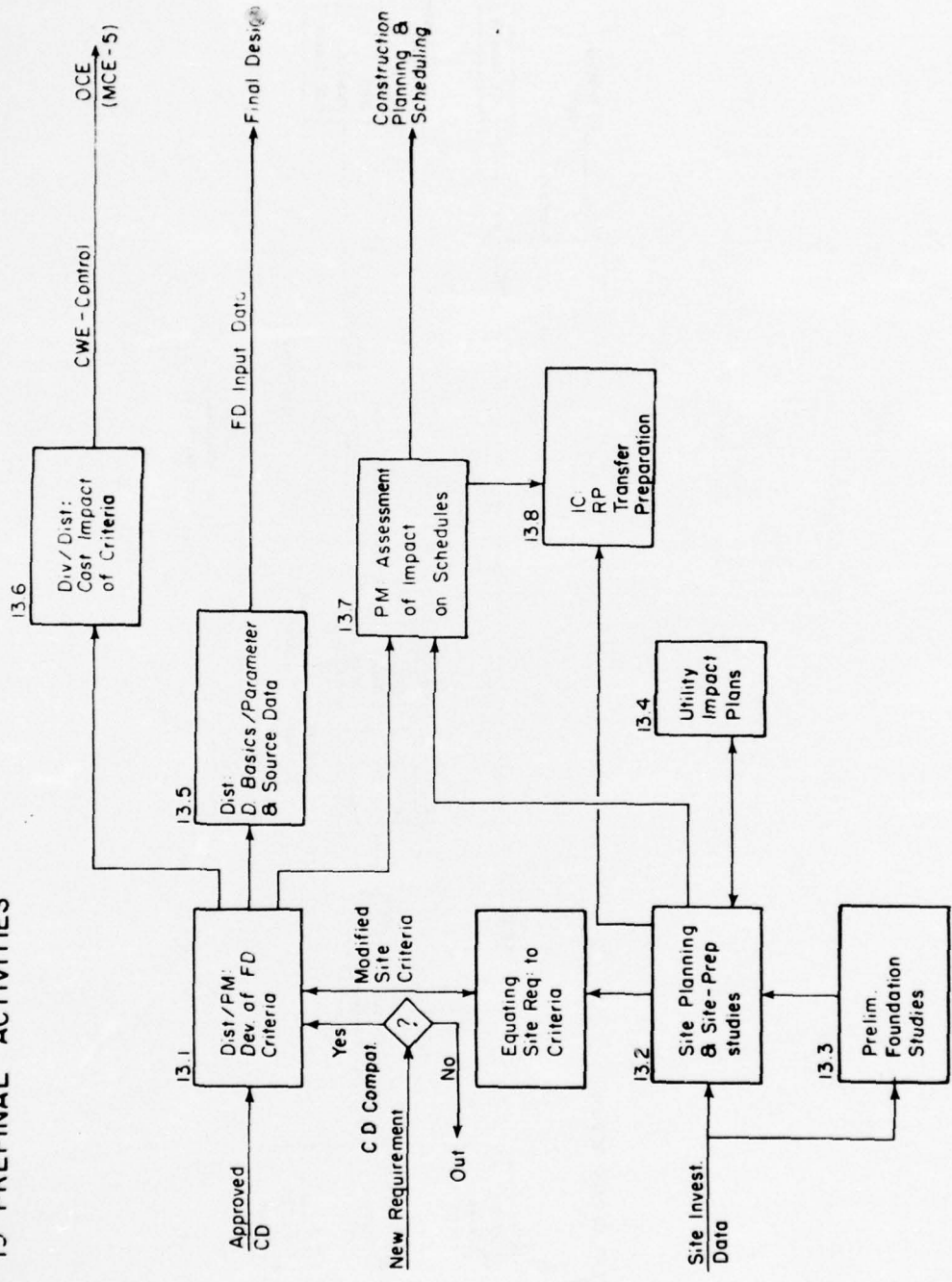

A-2

15.0 & 16.0 FINAL DESIGN AND FD REVIEW (CONTRACTED)

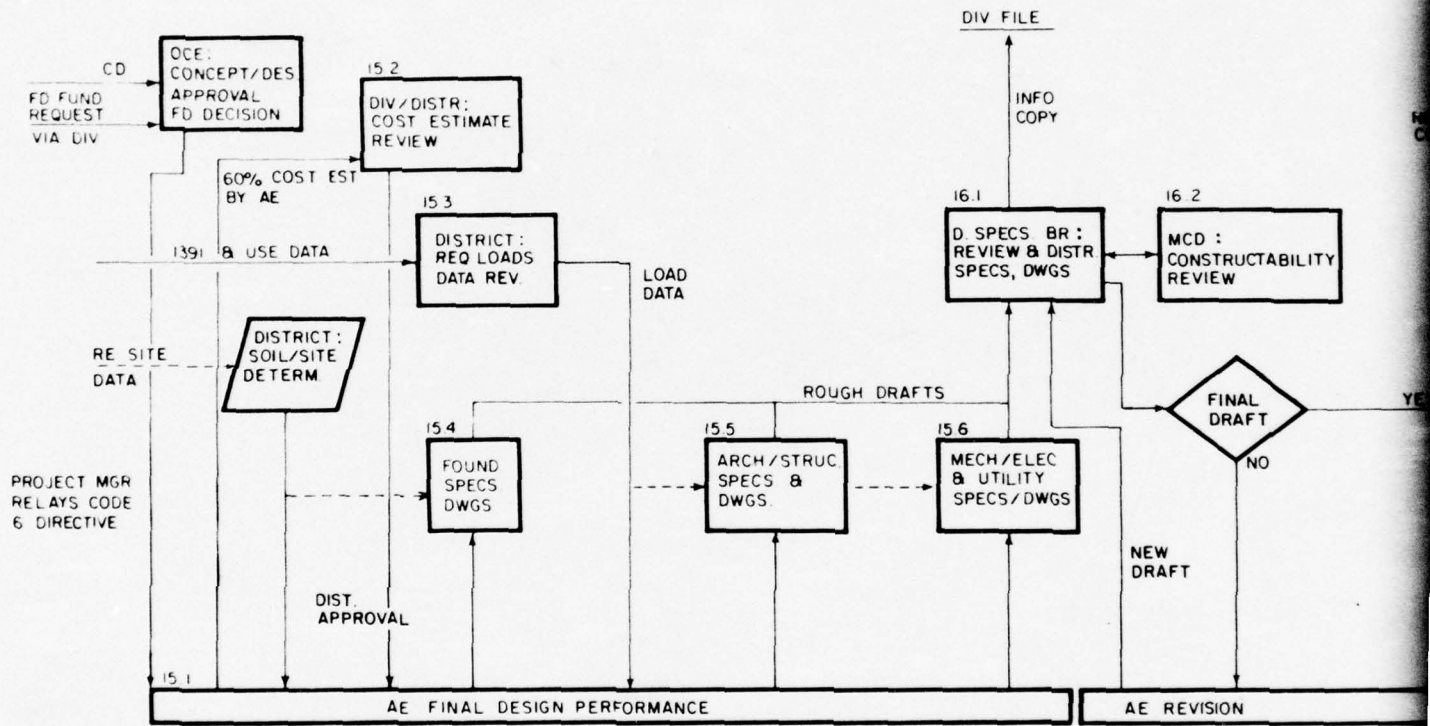

AND FD REVIEW (CONTRACTED)

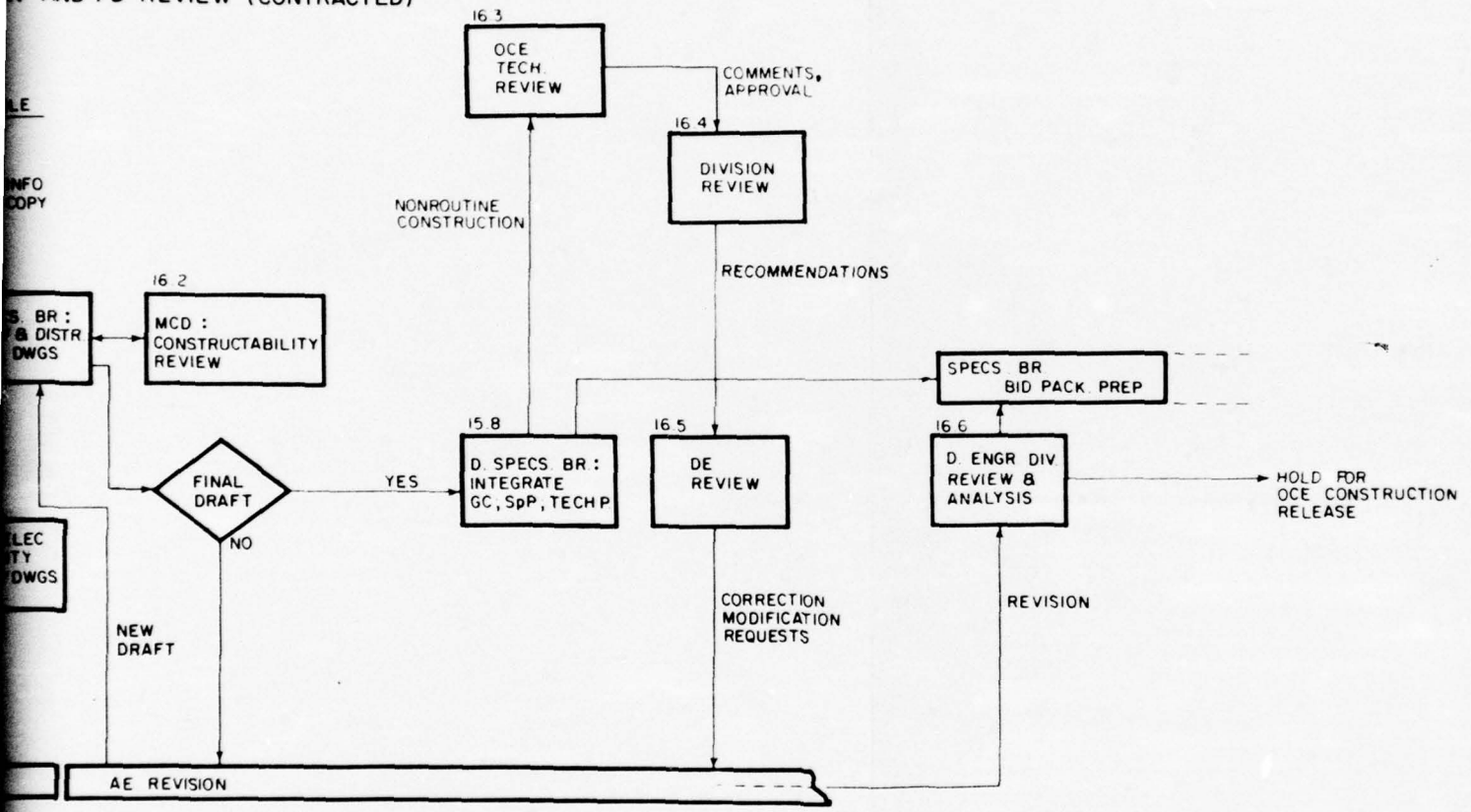

2

A-2
18.0 DISTRICT MC PROJECT CONTRACTING

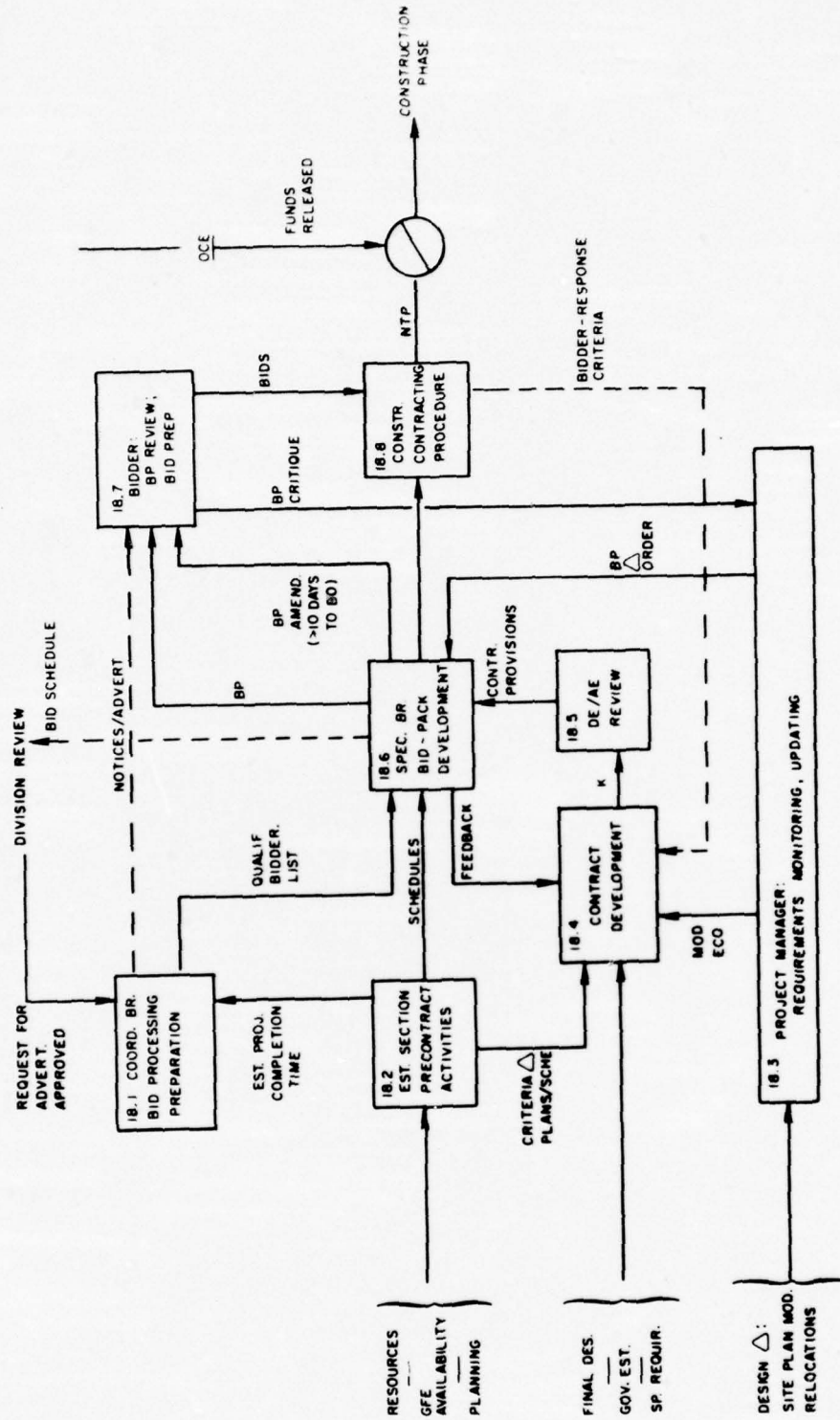

A-2

18.1 AND 18.2 MCA BID PROCESSING AND PRECONTRACT ACTIVITIES

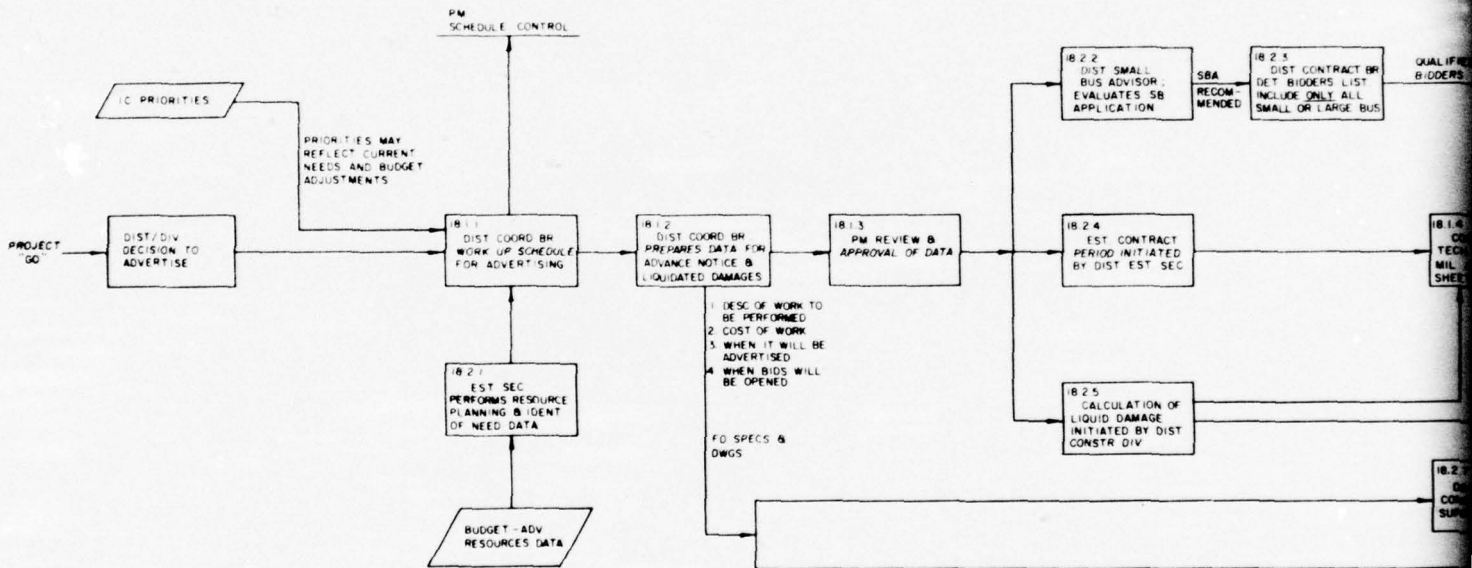

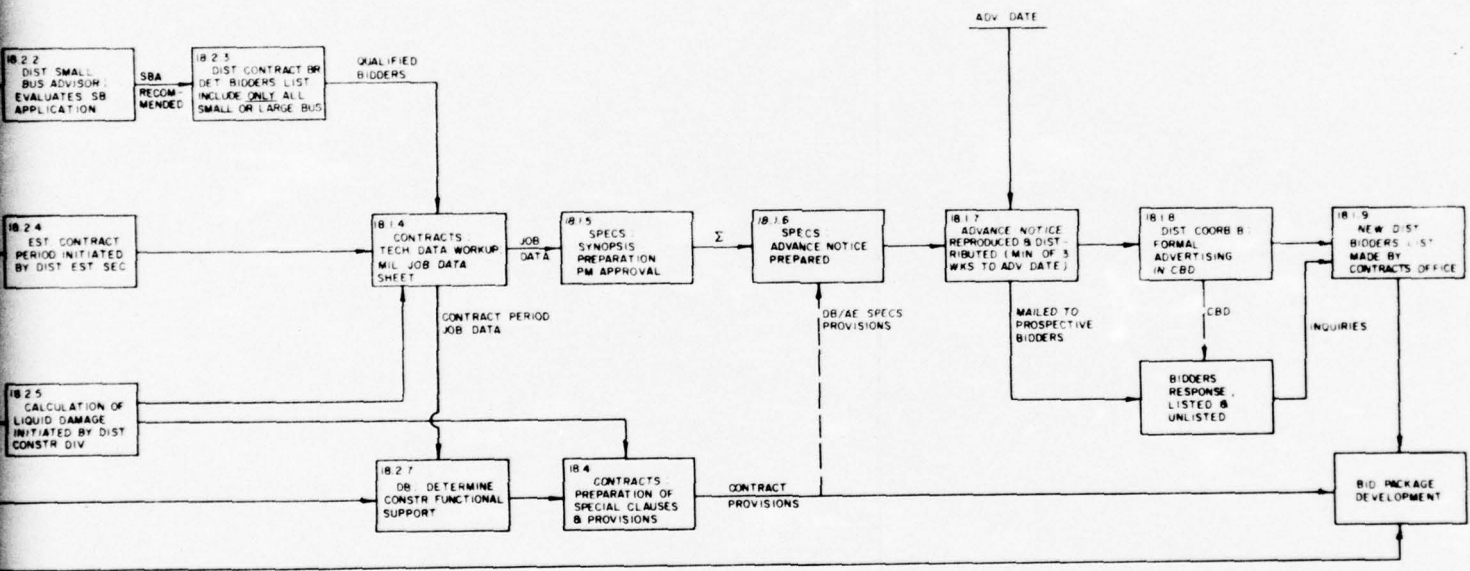

2

A-2
 18.6 TO 18.8 CONSTRUCTION CONTRACTING

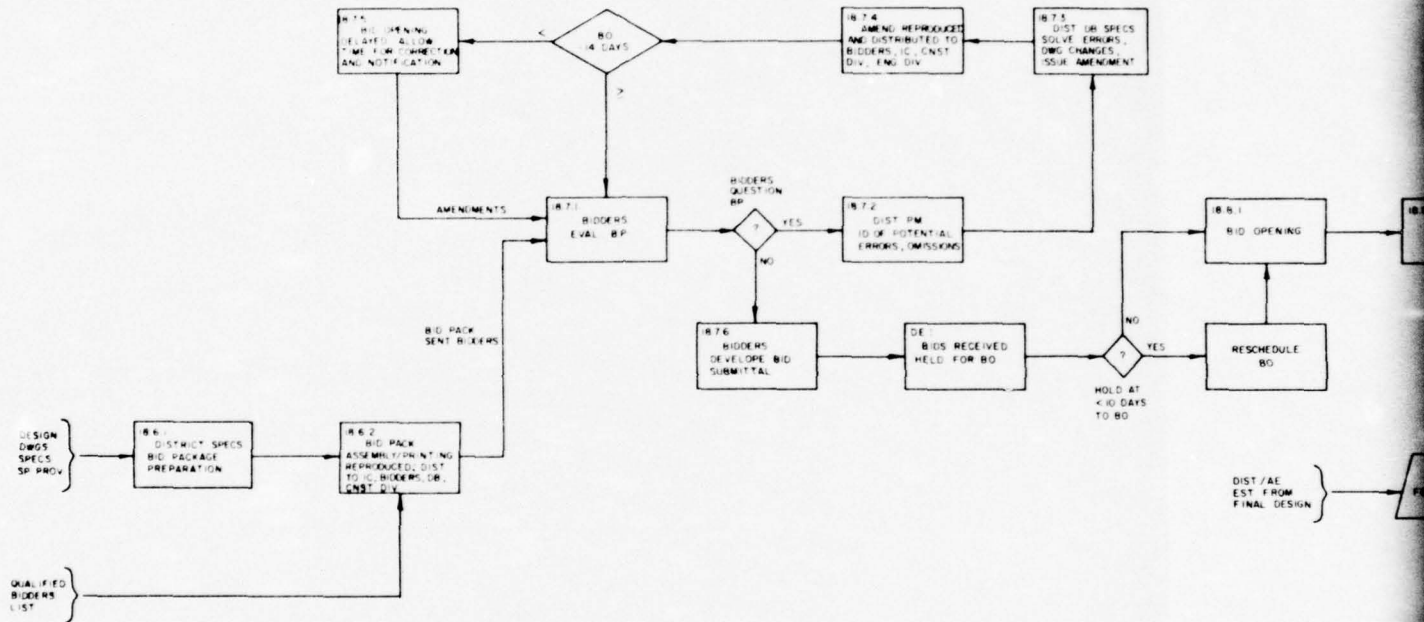

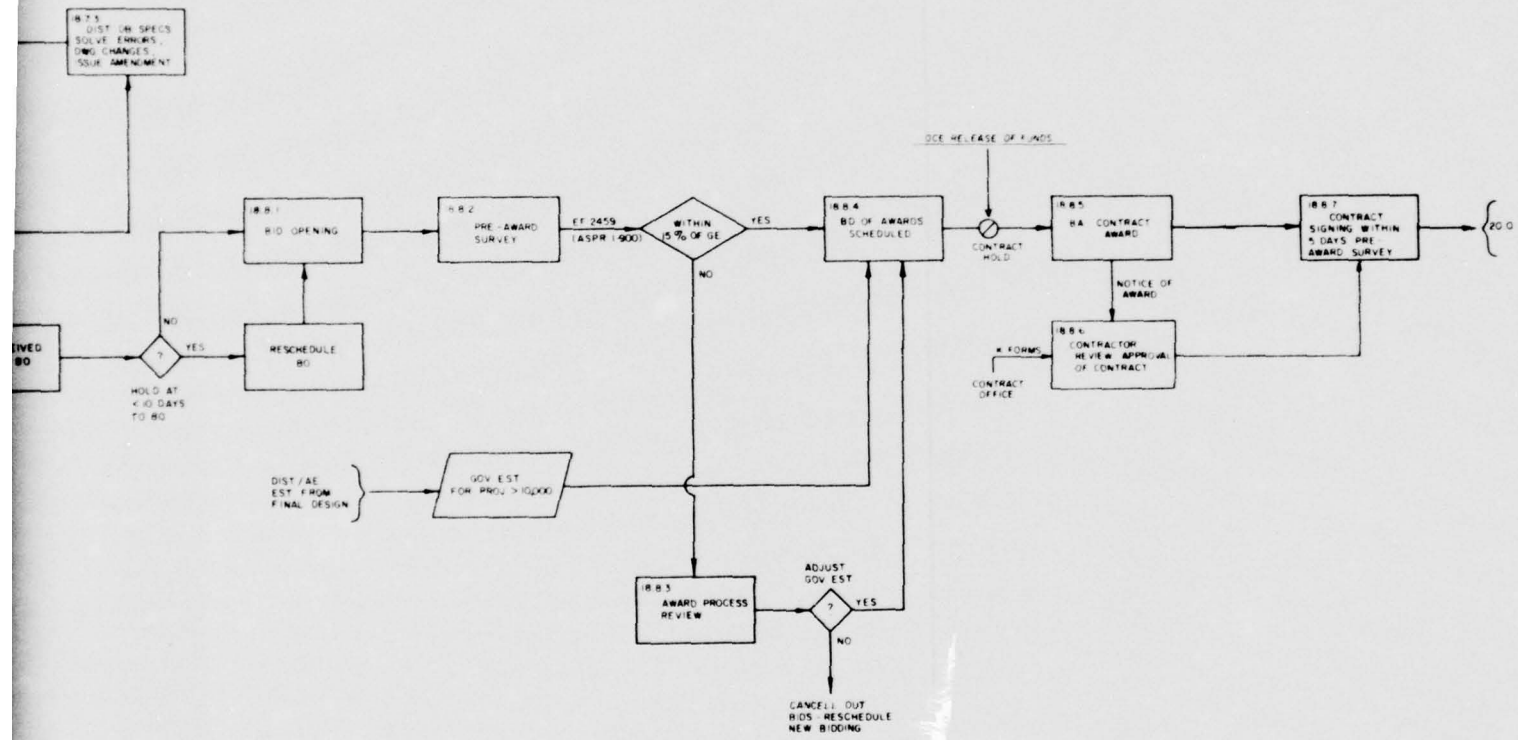

2

**A-2
201 AE CONTRACT COMPLETION**

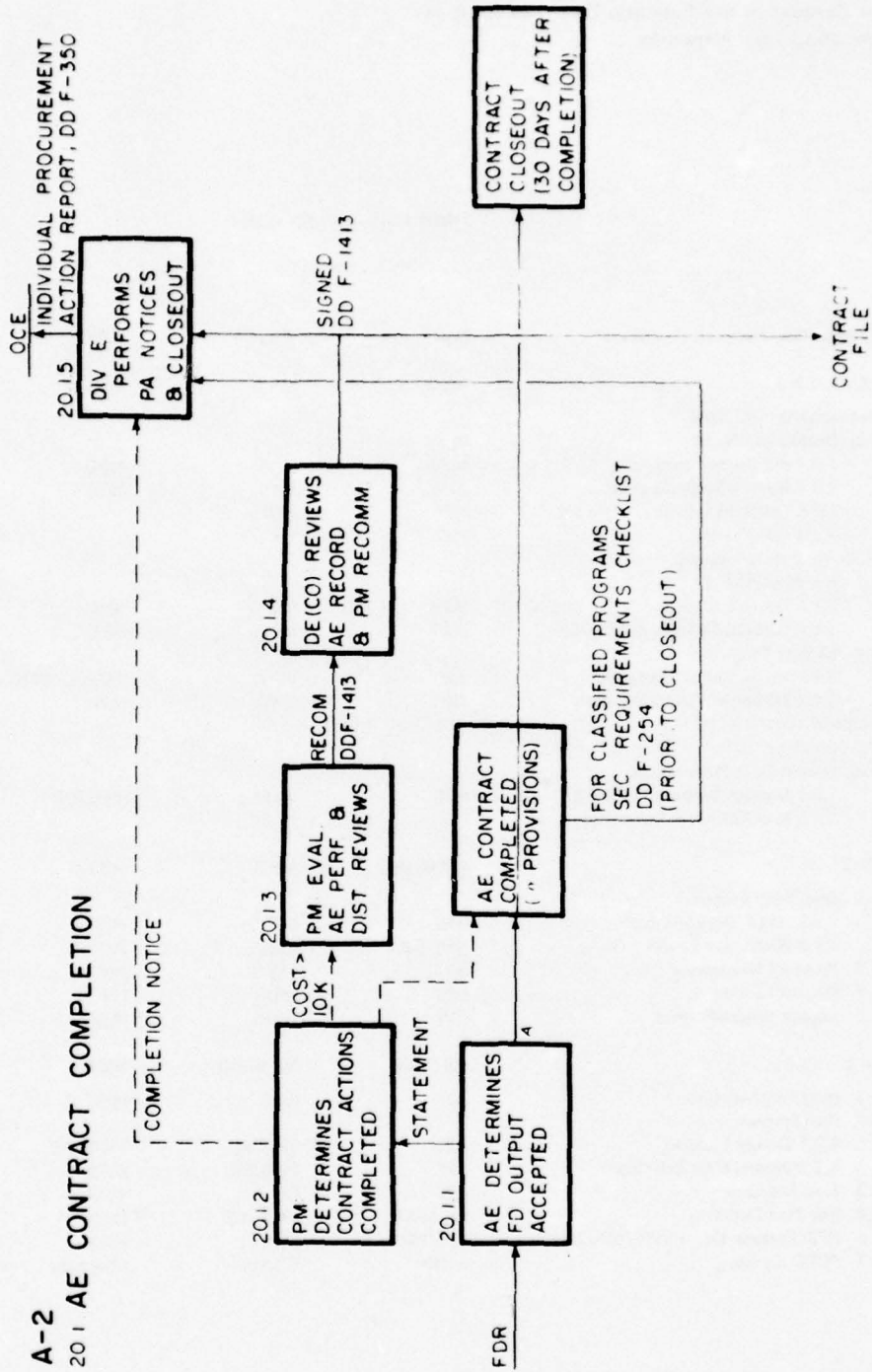

**A-3 Performance Practices of Selected Districts Within
the Context of the Function Blocks of MCA In-
formation Flow Networks**

Information Flow Network Functions	District Group Assignments			
	MRO	SAS	SPK	SWF
BLOCKS 1, 2 & 5	Mil B	Mil B	Mil DB	PMB
1.0 Determination of Need				
1.3 Installation Need				
1.3.1 MP Impact Support	MPS	MilPS	MPU	PIPrS
1.3.2 Project-Scope Support	APS	PMS	MPU	PIPrS
1.3.3 District Control/Cost Codes	APS	PMS		PIPrS
1.3.4 OM Costing	MPS	Est S		PIPrS
2.0 Planning & Programming				
2.1 IPB Meeting Call				
2.1.1 District Attendee	MPS	MilPS	MPU	PIPrS
2.1.2 Division Delegated Attendee	MPS	MilPS	MPU	PIPrS Ch
2.4 Facility Proposals				
2.4.1 District Study Support	APS	PMS	PES Ch/MPU	PIPrS
2.4.2 MP-Impact Determination	MPS	MilPS	MPU	PIPrS
5.0 Proposal Submittal (IC)				
5.1 Priority				
5.3 Project Data Preparation				
5.3.1 District Support to PDB-1	APS	MilPS	MPU/DB	PIPrS
5.3.2 MACOM/OCE Submittals				
BLOCK 3	Mil B; DB	Mil B	Mil DB	PMB
3.1 Dist. Eval. Proposal				PPS/ParS
3.1.1 ID Of Data Sources	APS	MilPS	PES	PIPrS
3.1.2 Manpower Loading (Est.)	APS/DB	PMS	PES	PIPrS
3.2 Proposal Monitoring	APS	MilPS	PM	PIPrS
3.3 Proposal-Scope	APS	PMS	PM	PIPrS
3.5 Impact Determination	APS	MilPS	PES	ArS
BLOCK 8	Mil B; DB	Mil B; DB	Mil DB	PMB & DB
8.1 Data Org./Analysis	APS	PMS	PES	ArS
8.2 Cost Impact				
8.2.1 Design Funding	APS	PM(CS)	PM/Est S	ArS
8.2.2 Project Cost Estimate	APS	PM(CS)	Est S	
8.3 Line Sketches	APS	Est S	MDS	ArS
8.4 Site Plan Detailing	Est S/APS	PM/Est S	Est S	Est S (DB)
8.6 PCD Package Dev. (3086/BDwgs+)	APS/PM	PMS	BrCh	(DB)
8.7 PCDP Review	to Div	Channels	Channels	Channels

*District and Division abbreviations are defined in the list following the table.

District Group Assignments

MCA Projects

Information Flow Network Functions	MRO	SAS	SPK	SWF
BLOCK 9	Div E; DE; ED; PSD	Div E; DE; ED; CD	Div E; ED; PSD	Div E; DE; ED; PSD
9.1 Organization, Preliminary	Mil B	PSD Mil B; DB	Mil DB; CDB	PMB; DB
9.1.1 Scheduling				
a. Overall	PM/APS	PM	BChs+PE-SCh	ArS
b. Design	APS	See 9.3.2	Same	ArS
9.1.2 Handling the Directive				
a. Receipt and distribution	Mail/CMS	CS	Channels	ArS
b. Procedural implementation	CMS (routing)	PM/CS	PE-S	ArS
c. Performance implementation (coordination meetings, etc.)	PM/APS/CMS	PM/CS	PM	ArS
9.1.3 Project Data Acquisition	APS	CS	PE-S	ArS
9.1.4 Funding (Request for)	APS	PMS	B&RS	PIPrS
9.2 Design Route Decision	Assoc. Branch Chs	Mil B, DB Chs	D Sect. Chs	DB Ch
9.3 AE Support Preparation	Mil B; PSD	Mil B; PSD	Mil DB; CDB; PSD	PMB; PSD
9.3.1 Documentation				
a. AE qualifications criteria	PM	Presel. Bd.	PM	PIPrS
b. Contract prep	PM/CMS/DB	PM/DB	PM/NS	PIPrS+
c. AE Package assembly	CMS	PM/CS	PM/NS	PIPrS
d. Cost Evaluation	APS	CS	Est S/B&RS	ArS
9.3.2 Surveys and Scheduling			See 9.1.1	
a. Advertisement dates	PM	CS		ArS
b. Design milestones	Mil B Ch.	CS/DB		ArS+
c. Control numbers assignment	PSD	PSD	PSD	PSD
9.3.3 Evaluation of AE Response	PM			
9.3.4 & 5 Conference coordination	CMS	PM	NS+BChs	ArS
9.4 AE Selection and Contracting	Mil B; DB; PSD	Mil B	Mil DB; CDB; PSD	PMB
9.4.1 Organize AE selection				
a. RFP preparation	CMS	CS	NS	ArS
b. AE authorization form signoff	DE			DE
c. Call-up Preselection Board	CMS	Presel. Bd.	NS	PIPrS
9.4.2 AE Fee (Calculate/Coordinate)	EstS/PM	Est S/CS	BChs/B&RS	ArS
9.4.3 Posting (<\$10K)	CMS	PM	PM	PIPrS
9.4.4 Advertising	PM/CMS	PMS		PIPrS
a. Synopsis prep			PE-S	
b. CB Daily placement			PSD	
9.4.5 Call-up AE Files	CMS/ADP	PM	NS	PIPrS
9.4.6 Formulation of Qual. List	PM/CMS	PM	NS	PIPrS
9.4.7 Preselect. Bd. Review & Selections	CMS Ch is	Mil PS	NS support	PIPrS
9.4.8 Preselections survey	Chairman	Supported	NS	PIPrS
9.4.9 Selection Board Decision				
9.4.10 AE Selection	SBd	SBd (BChs)	SBd	SBd
a. Preaward Survey	CMS	CS	NS	PIPrS
b. Request/Approval for AE	CMS/DE	Sel BdCh/DE	NS/DE	PIPrS/DE
c. Notification of AE	CMS	CS	NS	PIPrS
d. Scheduling of Meetings	CMS	CS/PM	NS	PIPrS
9.4.11 Audit				
a. Notification of DCAA	CMS	MCS/PM	NS	PIPrS
b. Request for Audit	DE	DE	DE	DE
9.4.12 Negotiation Preparation				
a. Acting team for negotiations	PMS Ch & CMS		Mil B Ch+Nego.	
b. AE Package preparation	PM	CS	NS/PM	PIPrS
c. Gov. Est. supplied	Est S (DB)	Est S (DB)	NS/Est S (CD)	Est S (DB)
9.4.13 Negotiations				
<i>Gen. of records/minutes</i>	<i>CMS rep</i>	<i>CB (PSD)</i>	<i>NS</i>	<i>ArS</i>

District Group Assignments

MCA Projects

Information Flow Network Functions	MRO	SAS	SPK	SWF
9.4.14 Approval of Parties	AE/DE/Div E			
9.4.15 Selection Form Signed	DE	DE	DE	DE
9.4.16 Chk for Avail. of Funds/ Cost Schedule	PM	PMS/PM	B&RS	PIPrS
9.4.17 Board of Awards	CMS		NS	PIPrS
a. Contract Approval Request	PM	PM to DE	NS	PIPrS
b. Contract Letter Awd		CB (P.S)	(Obsolete)	
9.4.20 Contract Coordination		CS		
a. Draft (for AE Pay Wage)		PM		
b. Preparation/issued	PSD	CB (P&S)	PSD	PIPrS
c. Signing & Administration	DE	CB (P&S)	DE	DE
9.5 Command Approval/Div Notification	DE	DE	DE	DE/PIPrS
9.7 Design NTP				
9.7.1 Div & Bd of Awd's Transmittal	CMS	PM	to PM	PIPrS
9.7.2 District trans. to AE (Phone/Letter) by:	CMS	CB (P&S)	PM	PIPrS
9.10 Project Plans (Post AE Selection)				
9.10.1 Design Criteria	PM	DBr	PM/DB	ArS
9.10.2 AE Package Update	CMS	PM	NS	ArS
9.10.3 VE Study Need-Determination	PM	VE	PM	ArS
9.10.4 Topo. Survey Request by:	PM	PM	PM	ArS
9.10.5 Soil Investigation Request by:	PM	PM	PM	ArS
BLOCKS 10 & 12	DB; Mil B	DB; Mil B	Mil DB, CDB, FMB	PMB, DB
10.1 Define Pre Plans - Site Plans	AE/WS	MPS	MPU	ArS
10.2 RE/Relocations	AE/WS	PM	PE S	Relo S
10.3 Arch. Function (floor plan)	AS	AS	DS	AS
10.4 Structures (frame)	S BS	SS	SS	SS
Pave & Grading		P & GS (DB)	F & MB	CivES
10.6 Mech Plans	ME S	MS	M/E (CDB)	MS
10.7 Mech Eq. Size & Utility II	MPSS	MS	M/E (CDB)	MS
10.8/9 Electrical	EFS	ES	M/E (CDB)	ES
10.10 Bldg Layout/Coord Checks	BS	DB	DS	AS
10.11 Utility Design	SanS	M/E S	US (CDB)	M/ES
10.12 Cost Takeoffs	Est S	Est S	Est S (CDB)	Est S
10.13 Review Comments (Σ)	PM	PM	PM	PM
12.5 Review - Δ Impact			TRS	ArS
12.5.1 Evaluates Δ	PM	DB		ArS
12.5.2 Trans to AE	PM	PM		ArS
12.7 Confirms Δ s	PM	PM	PM	ArS
12.8 Conc. Design Tx to OCE (if req)	PM/DE	DE	DE	ArS
BLOCKS 15 & 16	DB; Mil B		Mil DB	DB; CD
15.2 FD Cost-Est	Est S	Est S	Est S	Est S
15.8 Integrate Design Outputs	SpS	SpS	SpS (CDB)	DB
16.1 Rev./Distr. Specs/Dwgs.	SpS	SpS	SpS	ArS
16.2 Constructability Rev.	SIB(CD); Mil B	CRB (CD)	CB (CD) &	PMB &
	PM/CRS	& Mil B (ED)	Mil DB	CD
16.5/6 Final Review	DE/Div E	DE/Div E	DE/Div E	DE/Div E

District Group Assignments

MCA Projects

Information Flow Network Functions	MRO	SAS	SPK	SWF
BLOCK 18	etc.	etc.	ED; PSD; CD	ED; PSD; CD
18.1 Bidding Preparation				
18.1.1 Advert. Schedule	PM	PMS	PM/PSD	ArS; DB
18.1.2 Data Org./Prep.	SpS	PM/CS	SpS (CDB)	ArS
18.1.3 Contract (K) Data Review	PM	PMS/DBCh	SpS (CDB)	DB
18.1.4 K Prep. Control - Bid Schedule	PM	SpS/PM	SpS (CDB)	ArS
18.1.5 Synopsis Prep.	PM	CB (PSD)	PM	PSD
18.1.6 Advance Notice Prep	SpS	CS/CB	PM/SpS	PSD
18.1.7 Bid Data/Notice Distr.	SpS	CB	SpS	PSD
18.1.8 CBD Advertise Placement	PM	CB	PM	PSD
18.1.9 Project Bidders - List Dev.	SpS	PM/CB	SpS (CDB)	PSD
18.1.10 Bid Schedule Development	PM/ABCh/	PMS Ch	ABCh/PM	ArS
18.2 Precontract Activities				
18.2.1 Resources & Needs (ID)	PM	PM	PM	PSD
18.2.2 SBA Review Request	SBA Rep.	SBA Rep.	SBA Rep.	SBA Rep.
18.2.3 Bidders List Adjustments		PM	SpS/PSD	PSD
18.2.4 Est of K Time & Money		CRB/Est S	PM/MDS	ArS; C D
18.2.5 Calc. of Liq. Damage Clause	SIB (CD)	CD/PM	CD	CD; ArS
18.2.6 Dev. of Firm Bid Procedures	SpS	PM	SpS	CD; PSD; Council
18.2.7 Req. Construction - Support Determ.	CD	CD	CD	CD
18.2.8 Generation of Nec. Permits	PM	CD	RE/PM	RE; ArS
18.3 Requirements Monitoring	PM		PM	ArS
18.4 Contract (K) Development				
18.4.1 Prep. of Special Provisions & Instructions	SpS	SpS	SpS	DB, ArS; CD
18.4.2 Prep. of Tech. Provisions	SpS	AE/DB	AE/MDS	DB
18.4.3 (Integrated) Review of VE & Lost Effort Aspects	SpS	PM/DB	PM	DB, ArS
18.4.3 Modification & Updating	SpS	PM	CS(CD)/TRS/SpS	DB
18.4.4 Physical Preparation/Distr. (internal)	SpS	CB (PSD)	SpS/Repro	ArS
18.5 Integrated Review of K &/or BP Data	PM	Channels	PESCH	
18.6/7 Bid Package (BP) Dev./Distr.				
18.6.1 Integration of K & Instruct.	SpS	SpS	SpS	PMB, DB; PSD; CD
18.6.2 BP Review/Approval - Coord./Release	PM	PM	PESCH/DE	DB; PSD
18.6.2 BP Printing/Distrib.	PSD	Repro B	PSD	PSD
18.7.4 Amendment Process	PM	PM	PM/SpS	SpecS; Ar S; PSD
18.8 Construction Contracting Procedure				
18.8.1 Bid Opening	Deputy DE	DE(CO)	DE/PSD Ch	PSD
18.8.2 Preaward Survey	PS Team	B/Awd	B/Awd	CD
18.8.3 Award Process Review (Bids Out)	PM	B/Awd	Div E	CD
18.8.4/5 Contract Awarded	Board of Awd	B/Awd	B/Awd	PSD
18.8.6 Approval of K	DE	DE	DE	DE; Counsel
18.8.7 Contract Signed	DE(CO)	DE(CO)	DE(CO)	DE(CO)
18.8.8 Official Records Filing	PSD	PSD	PSD	PSD

District Branch and Section Designations

Missouri River Division, Omaha District (MRD)

Engineering Division (ED)

Mil B – Military Branch
A(E/W)S – Army (East/West) Sections
AFS – Air Force Section
APS – Advance Planning Section
BRS – Budget and Reports Section
CMS – Contract Mgt. Section
MPS – Master Planning Section

DB – Design Branch
AS – Architectural Section
BS – Building Sections
E(F/PS)S – Electrical Sections
Est S – Estimating Section

M(F/PS)S – Mechanical Sections
SS – Structural Section
SanS – Sanitary Section
SpS – Specifications Section

FMB – Foundations and Materials Branch
FS – Fo., Materials & Airfield Pavement Section
GS – Geology Section

Construction Division (CD)

SIB – Supervision and Insp. Branch
(W/E)CS – (Western/Eastern) Construction Sections
CRS – Constructability Review Section
M&ES – Mech. and Elect. Section

CAdm. B – Contract Administration Branch

Procurement and Supply Division (PSD)

South Atlantic Division, Savannah District (SAS)

Engineering Division (ED)

Mil B – Military and Postal Branch
CS – Coordinating Section*
MilPS – Military Planning Section
PMS – Program Management Section

DB – Design Branch
AS – Architectural Section
DS – Drafting Section
ES – Electrical Section
Est S – Estimating Section
MS – Mechanical Section
P&GS – Paving and Grading Section
PES – Project Engineering Section

* The Coordinating Section has recently been regrouped into the Army Projects Management and the Special Projects Management Sections.

SS – Structural Section
Sp S – Specifications Section

F&MB – Foundations and Materials Branch
GS – Geology Section
SoilS – Soils Section

Construction Division (CD)

CRB – Constructability Review Branch
SIB – Supervision and Insp. Branch

Procurement and Supply Division (PSD)

CB – Contracts Branch

South Pacific Division, Sacramento District (SPK)

Engineering Division (ED)

Mil DB – Military Design Branch
B&RS – Budget and Reports Section
MDS – Military Design Sections A and B
MPU – Master Planning Unit (PES)
NS – AE Negotiations Section
PES – Project Engineering Section
TRS – Technical Review Section

CDB – Civil Design Branch*
Est S – Estimating Section
M/EDS – Mech/Elect Design Section
SpS – Specifications Section
US – Utilities Section

F&MB – Foundations and Materials Branch
GS – Geology and Concrete Section
Surv S – Survey Section

Construction – Operations Division (CD)

CB – Construction Branch

Procurement and Supply Division (P&SD)

C C'B – Contracts Branch

Southwest Division, Fort Worth District (SWF)

Engineering Division (ED)

PMB – Project Management Branch
AFS – Air Force Section
ArS – Army Section
PIPrS – Planning and Programming Section

DB – Design Branch
AS – Architectural Section

*The listed CDB sections may also support MCA design.

DS - Drafting Section
ES - Electrical Section
Est S - Estimating Section
MS - Mechanical Section
SS - Structural Section
SpS - Specifications Section

F&MB - Foundations and Materials Branch
GS - Geology Section
P&MS - Paving and Materials Section
Soils - Soils Design Section
Surv.S - Survey Section

Construction Division (CD)

Procurement and Supply Division (PSD)

General

AE - Architect and Engineer Firm
CO - Contracting Officer
DivE - Division Engineer
DE - District Engineer
PM - Project Manager
SBA - Small Business Advisor
XCh - Chief of -

A-3
94 AWARD OF AE CONTRACT (SACRAMENTO DISTRICT)

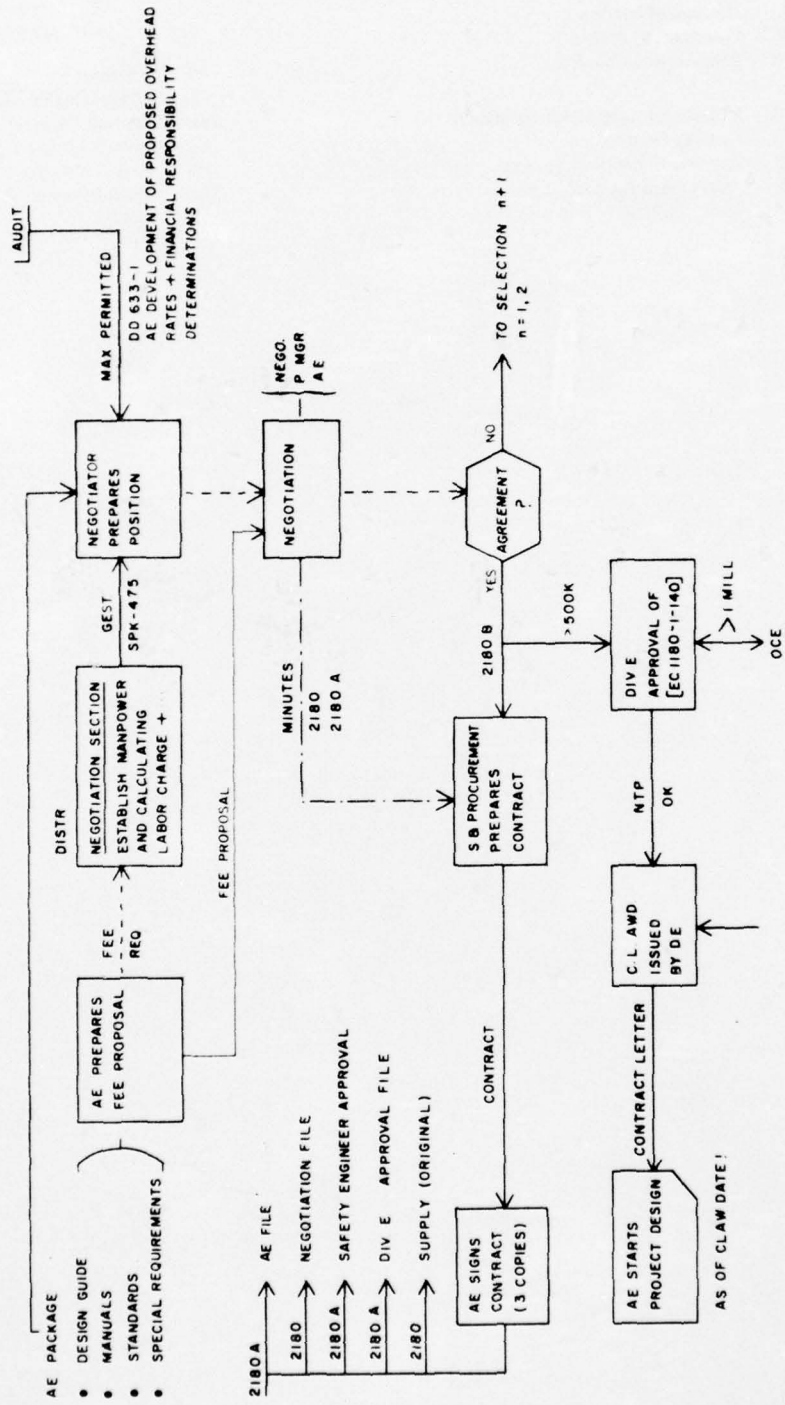

A-3

DISTRICT COST CONTROL SYSTEM

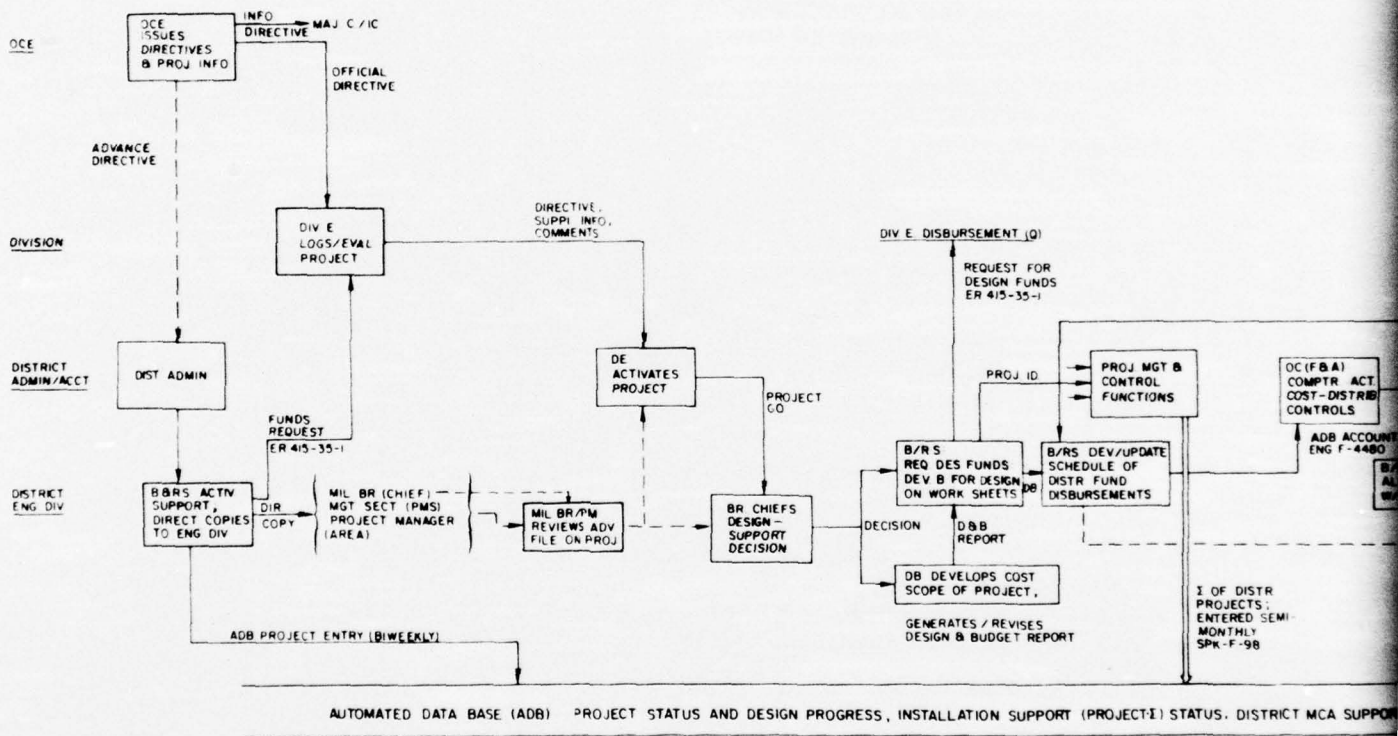

REQUEST FOR DESIGN FUNDS 415-35-1

PROJ ID
B/S DEV/UPDATE SCHEDULE OF DISTR FUND DISBURSEMENTS
B/S COST PROJECT
REVISES BUDGET REPORT

1 OF DISTR PROJECTS ENTERED SEMI-MONTHLY SPR-F-98

OCE REVIEW & ANALYSIS

INFO COPY ENG F-3018c

PROJECTED PLANNING & DESIGN COSTS

DIV E REVIEW

MONTHLY DESIGN MGT REPORTS

DESIGN BUDGET REVISION DATA

OC (FBA) COMPTR ACT COST-DISTRB CONTROLS

GROSS COSTS REPORT (Q) ENG F-3018c

ADB ACCOUNT ENTRY ENG F-4480

B/S ALLOCATES \$ W/IN P BUDGET

PROJECT COST SCHEDULE

COST SCHEDULE REALISTIC ?

B/S EQUATES COST SCH TO D EXP

ACOST/D-PROGRESS RATIO

DESIGNER

DESIGN STATUS REPORTING

FBA BR CLORD OF COST SCHEDULE

B/S PM PREP OF PROJ DATA FOR I PR

FY RECAP OF DESIGNER COSTS (AE OR DB)

IN SUPPORT (PROJECT) STATUS. DISTRICT MCA SUPPORT SUMMATIONS (S)

2

**A-4 Family Housing Construction and
Improvement Procedures**

A-4
**PERFORMANCE AREA
 FH NEW CONSTRUCTION**

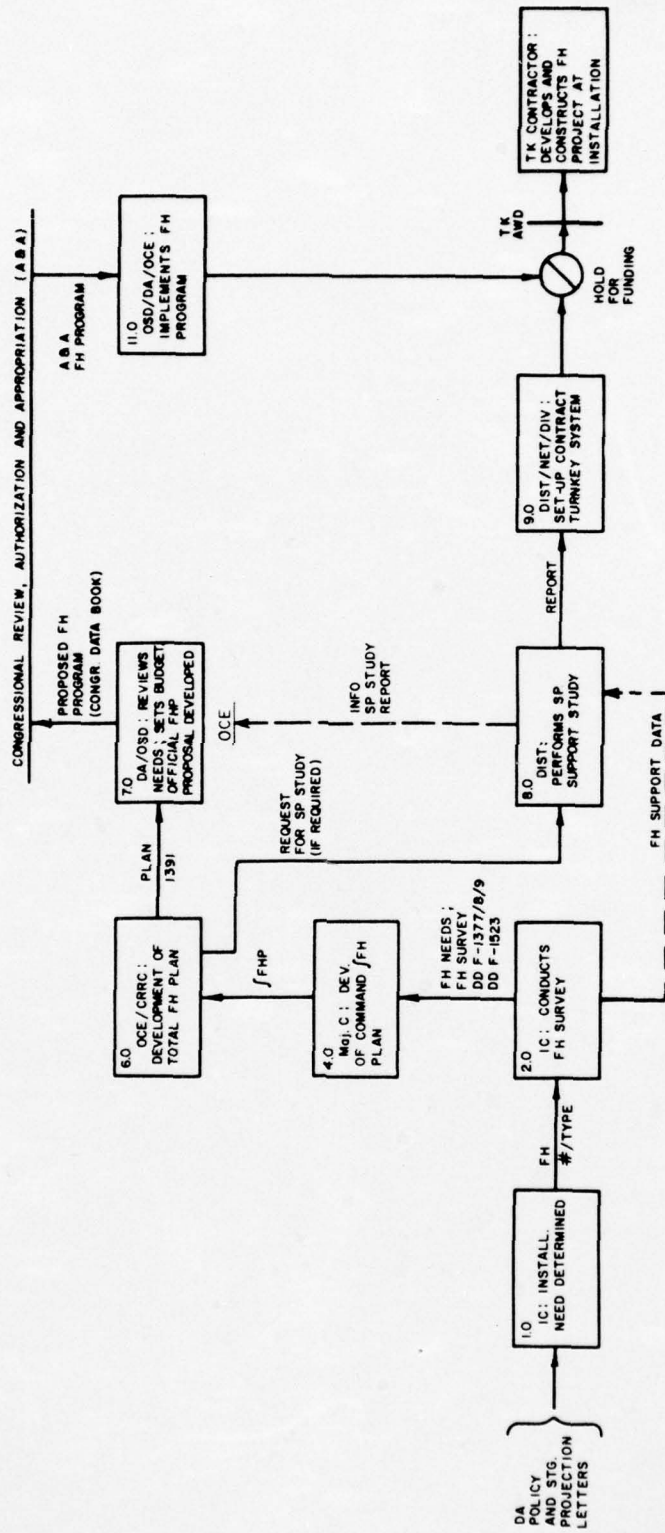

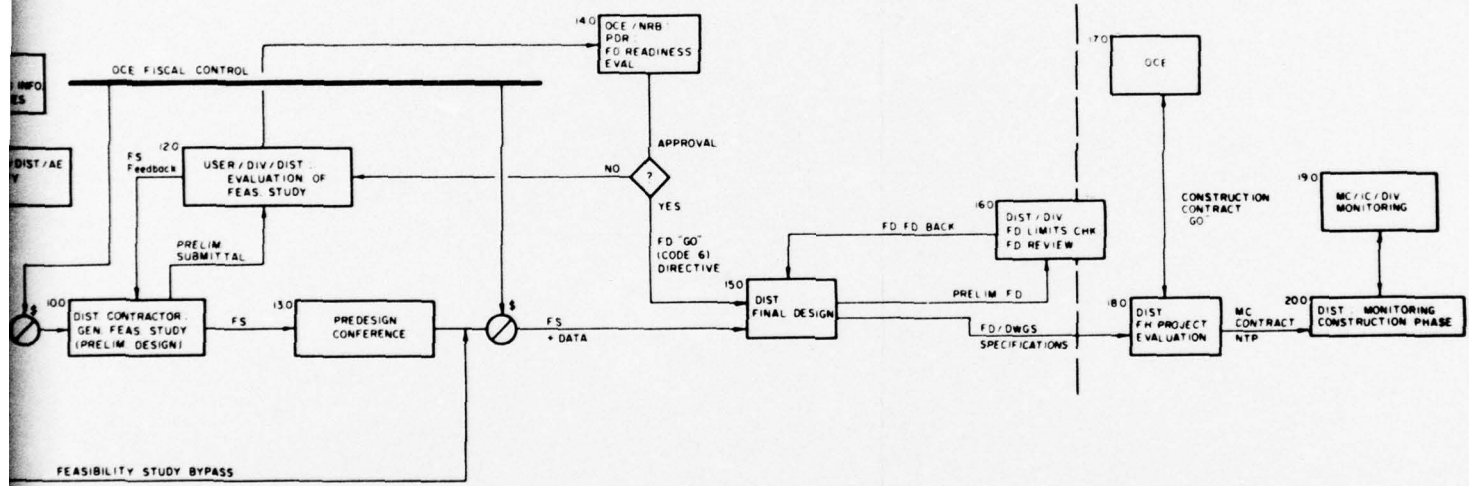

2

**APPENDIX B: MCA PROJECT
PROCEDURES, FOREIGN**

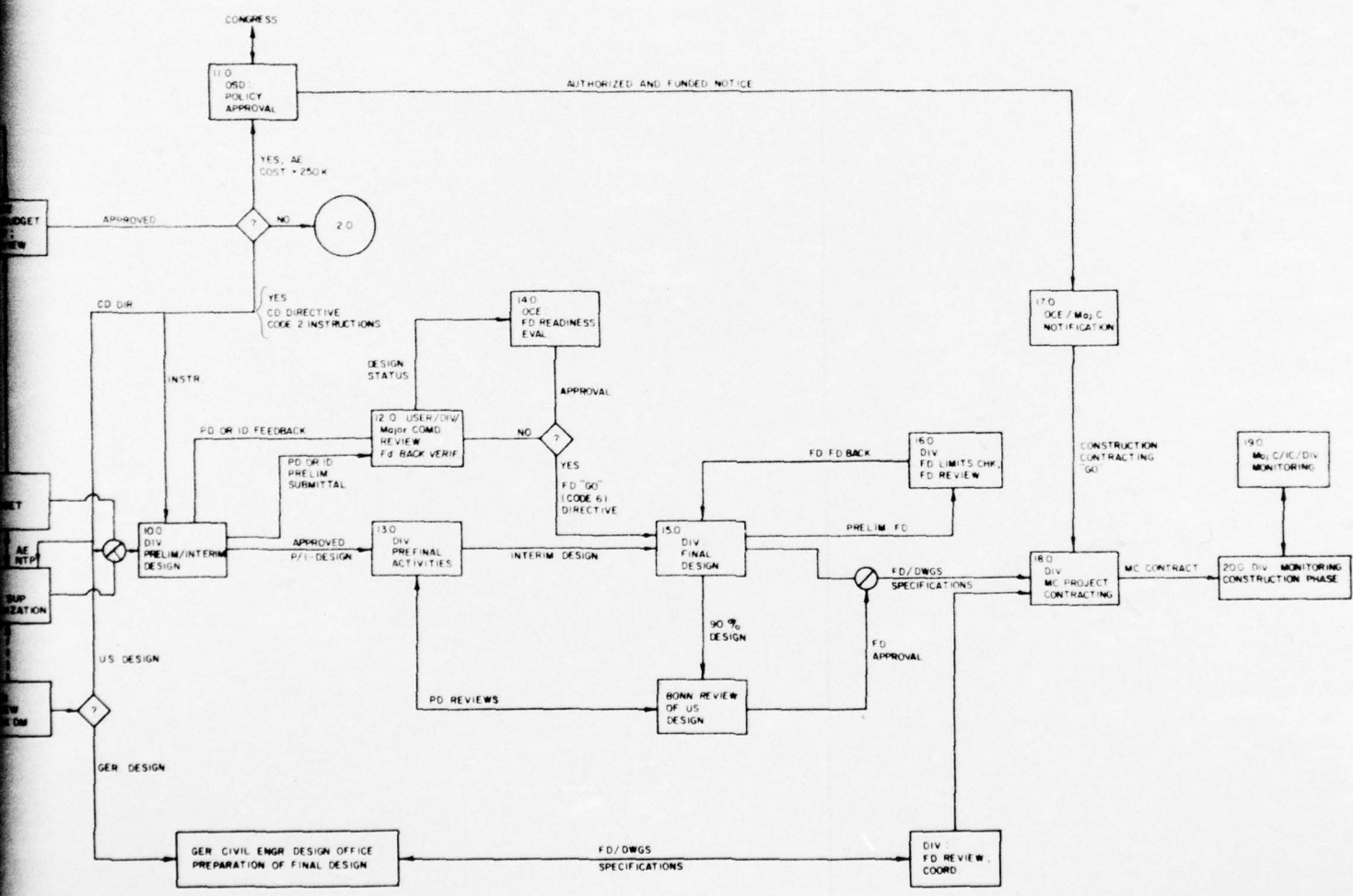

SOURCE ADOLPH FAUST, EUD

2

EUD PERFORMANCE AREAS (ITALY)
MC PROJECTS

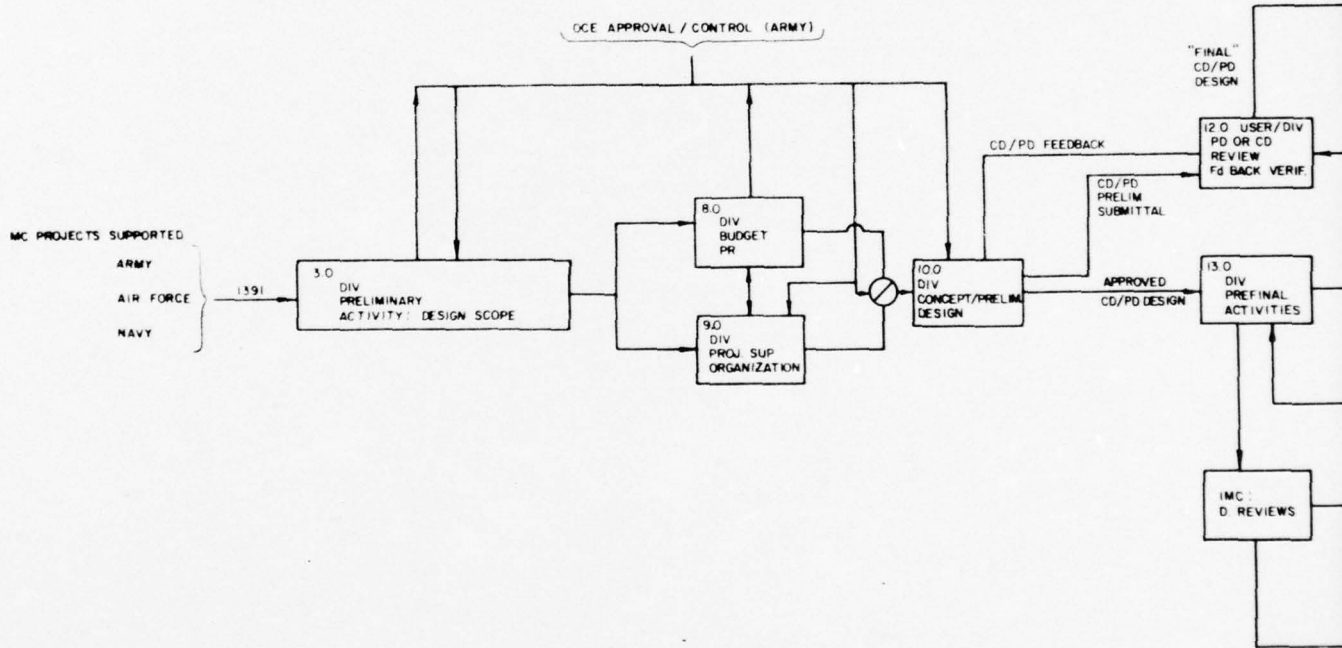

AD-A033 363

CONSTRUCTION ENGINEERING RESEARCH LAB (ARMY) CHAMPAI--ETC F/G 13/13
INFORMATION FLOW FOR MILITARY CONSTRUCTION.(U)
OCT 76 J H JOHNSON

UNCLASSIFIED

CERL-IR-ADS-2

NL

2 of 2
ADA033363



END
DATE
FILMED
2 - 77



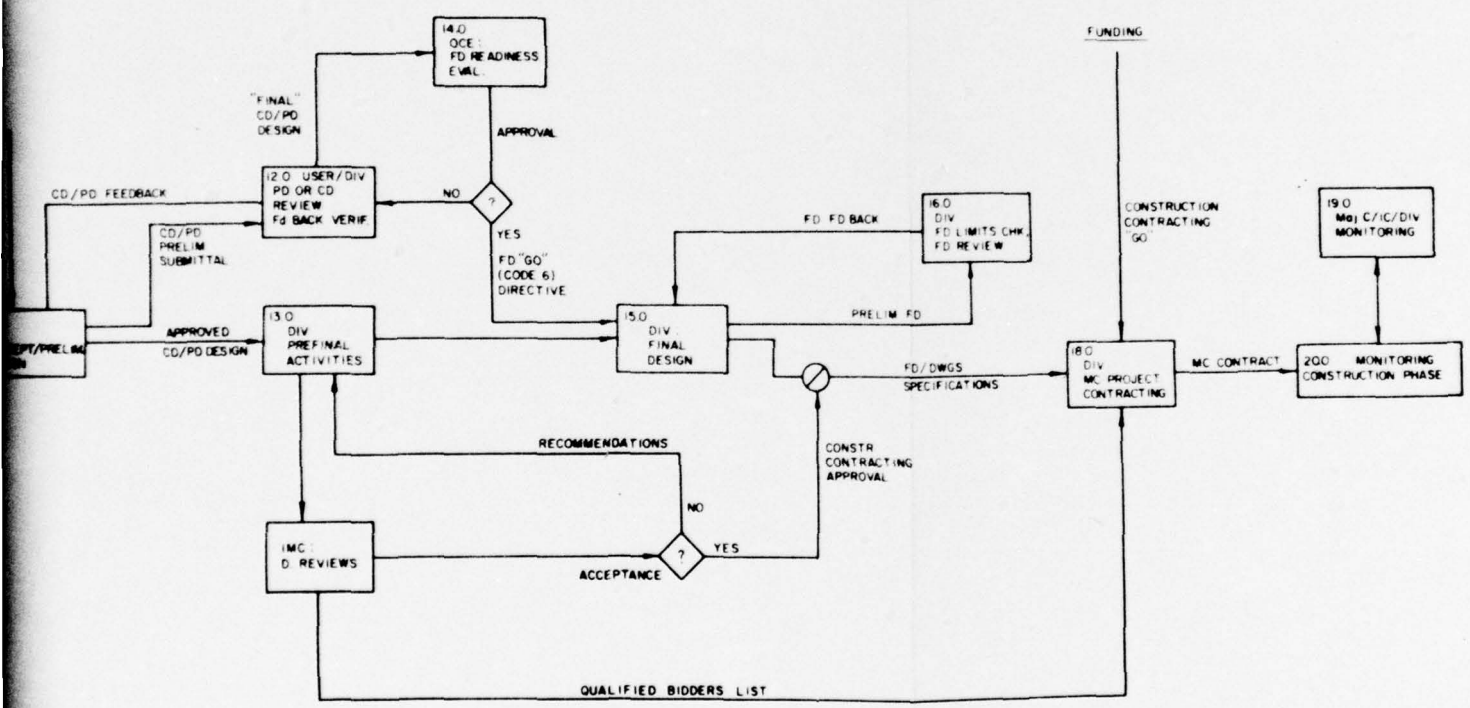

**APPENDIX C: ARMY RESERVE CENTER
CONSTRUCTION PROJECT
PROCEDURES**

PERFORMANCE AREAS
ARMY RESERVE CENTER (ARC) CONSTRUCTION

PROGRAM DEVELOPMENT

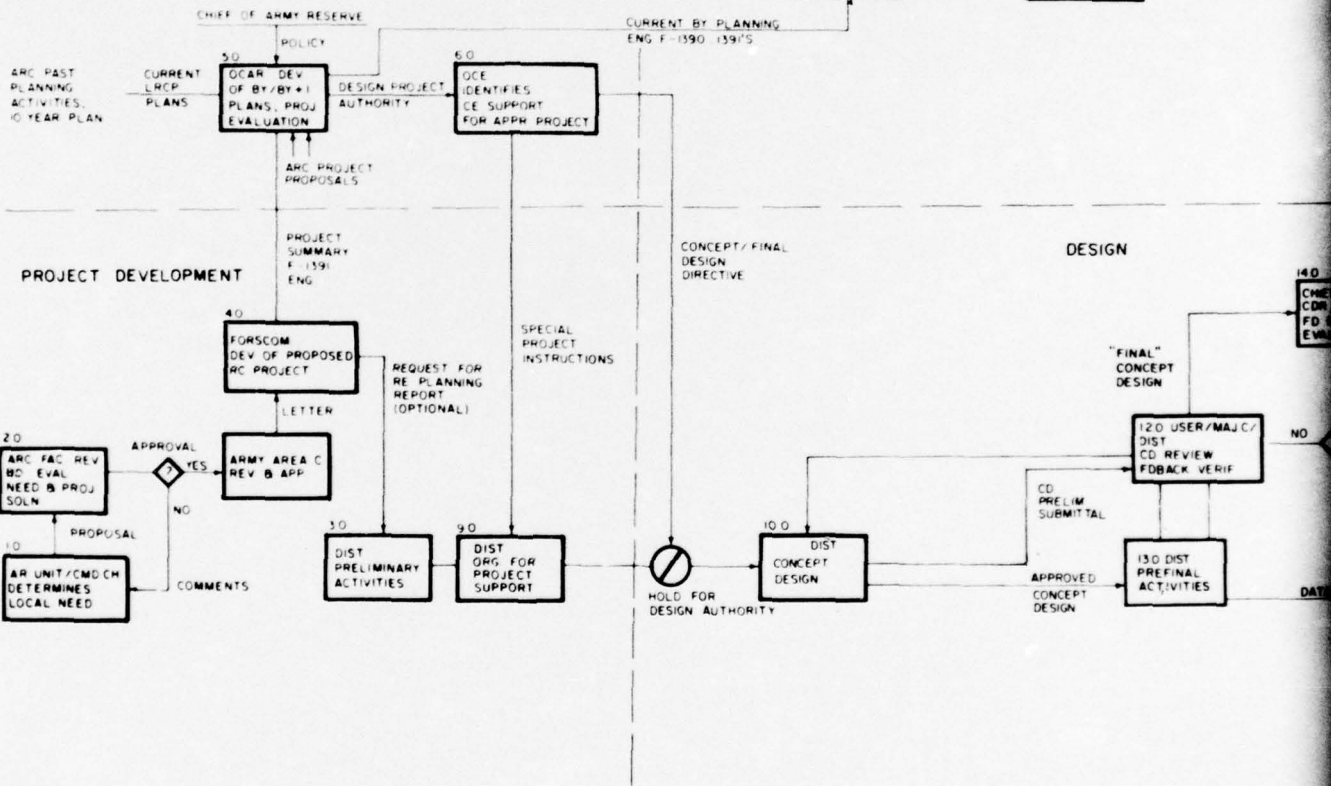

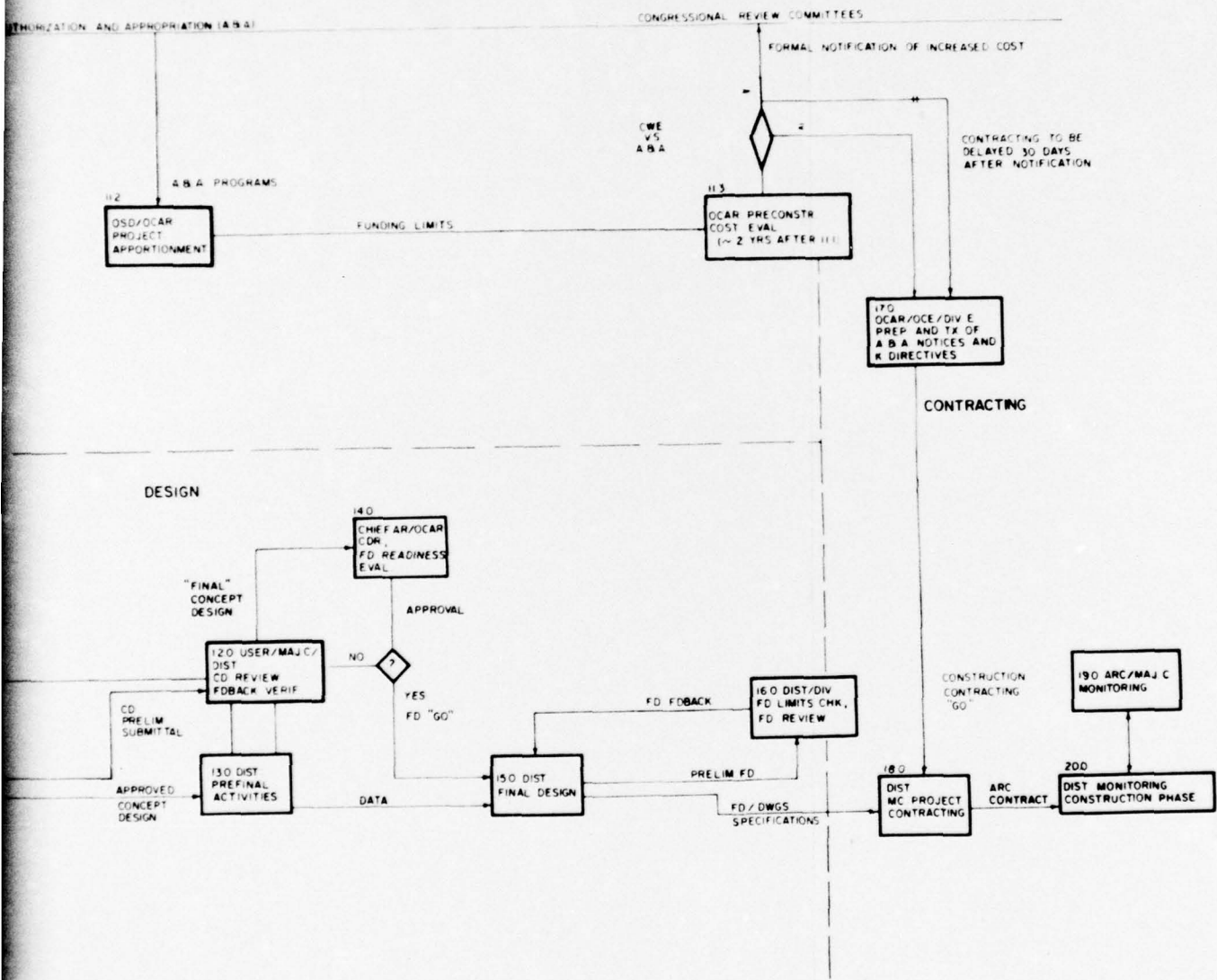

2

**APPENDIX D: AIR FORCE CONSTRUCTION
PROJECT PROCEDURES**

PERFORMANCE AREAS
AIR FORCE CONSTRUCTION PROJECTS

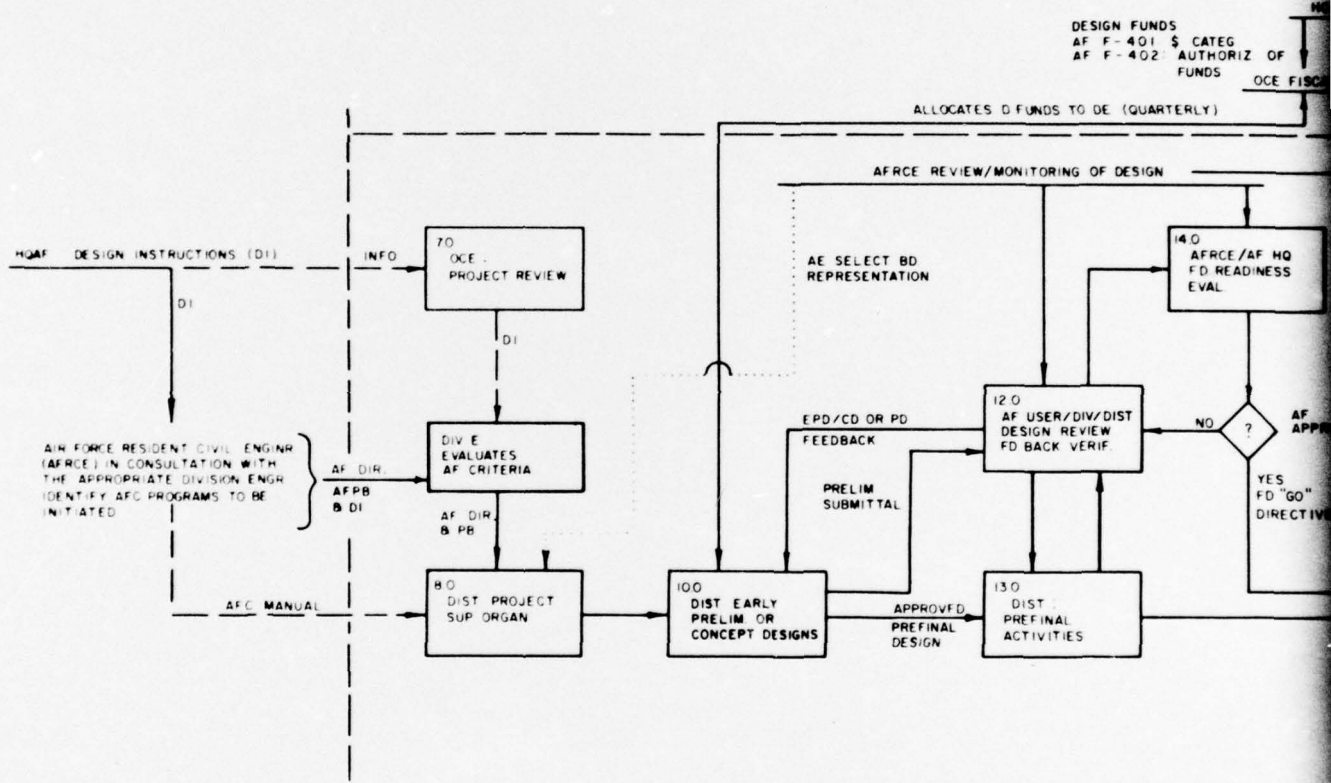

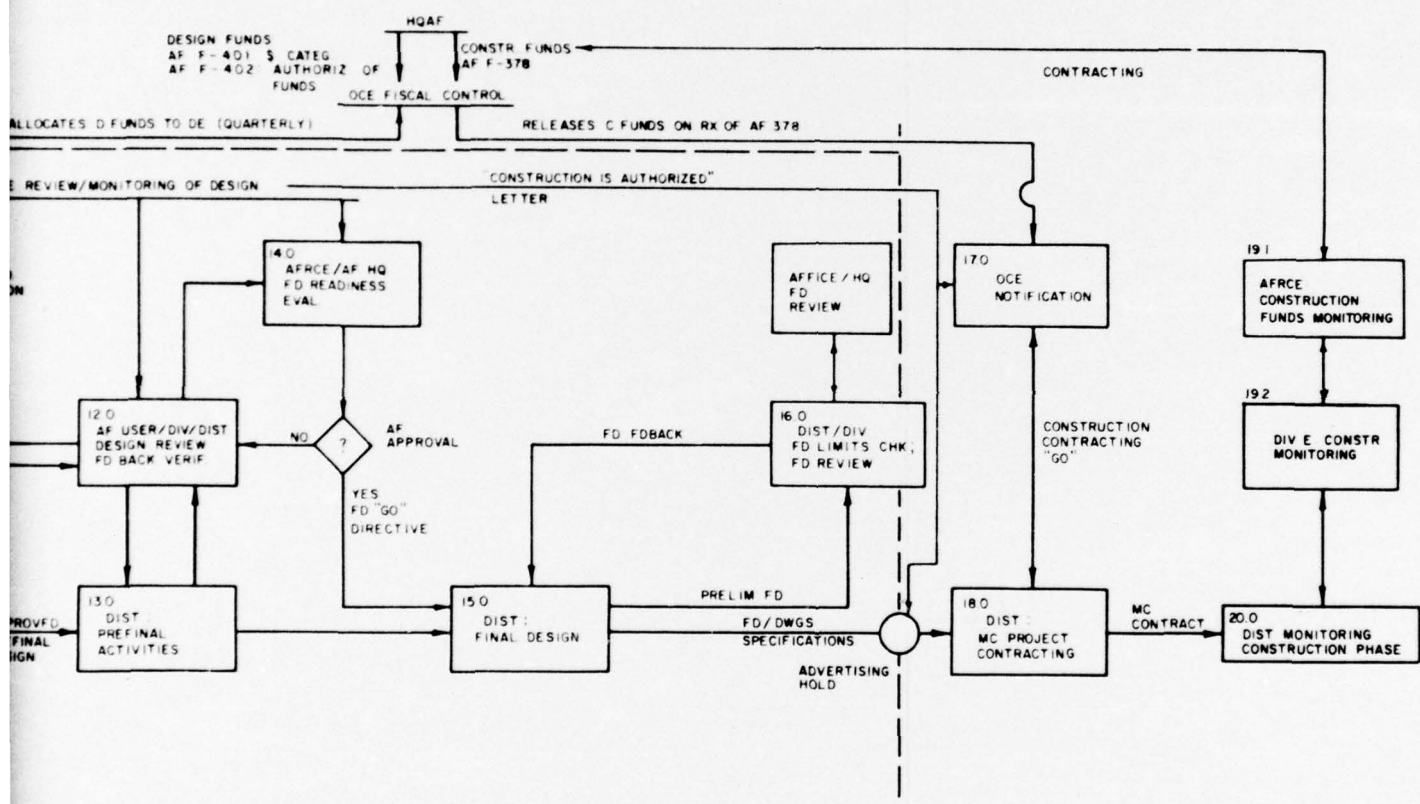

2

**APPENDIX E: NASA CONSTRUCTION
PROJECT PROCEDURES**

BASIC FUNCTIONS
NASA CONSTRUCTION

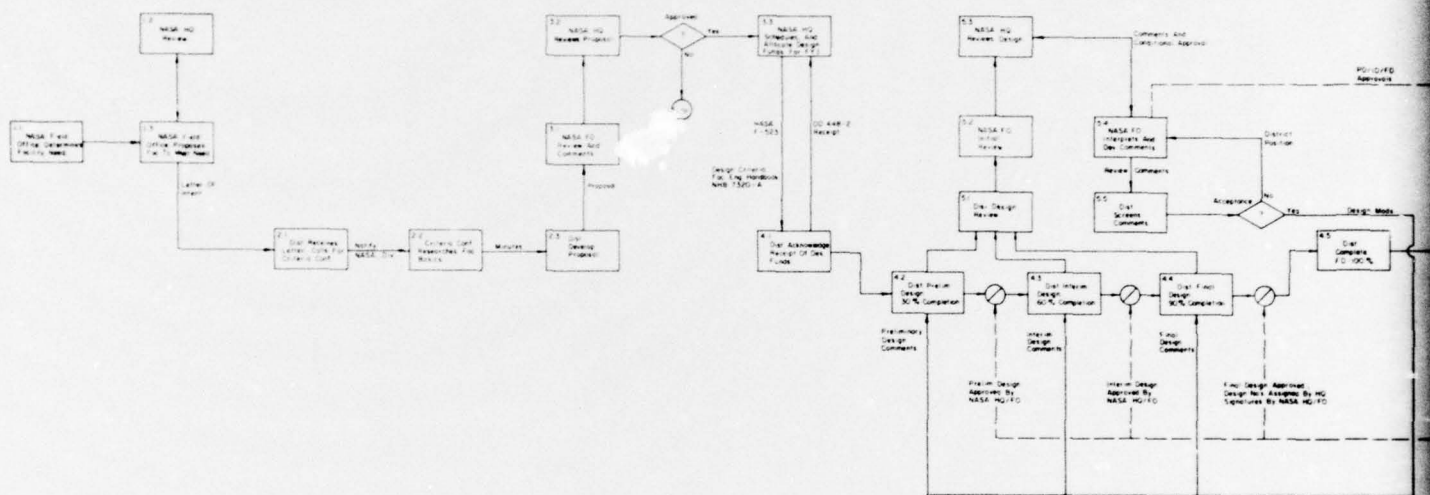

APPENDIX F: CODE DESIGNATIONS FOR OCE DIRECTIVES

- | Code | OCE Directive |
|------|--------------------------------------------------------------------------------------------------------------------------------------------------------------------------------------------------------------------------------------------------------------------------------------------------------------------------------------------------------------------------------------------------------------------------------------------------------------------------------------------------------------------------------------------------------------------------------------------------------------------------------------------------------------------------------------------------------------------------------------------------------------------------------------------------------------------------------------------------------------------------------------------------------------------------------------------------------------------------------------------------------------------------------------------------------------------------------------------------------------------------------------------------------------------------------------------------------------------------------------------------------------------------------------------------------------------------------------------------------------------------------------------|
| 1 | Authorized for budget drawings and additional design, limited to extent described by individual directives issued by OCE. Submission of cost estimates is also required. |
| 2 | New items not previously authorized for design. Authorized for preparation and submission of budget drawings, outline specifications, and cost estimates. Also, preparation of concept design, which is the first element of design. It includes drawings and data developed prior to the initiation of final design. It is intended to firmly define functional and basic technical aspects of a facility so that changes will not be required during final design. Concept design includes (1) a site plan, (2) floor plans showing functional layout, (3) typical cross sections showing floor-to-floor height, (4) elevations indicating principal exterior materials to be used, (5) an outline of materials and methods of construction with a schedule of typical finishes, and (6) cost estimates of the structure, site work, and utilities. Electrical, mechanical, and structural aspects will not be developed beyond basic determinations <i>except in those cases where they have particular importance related to the specific function for which the facility is intended.</i> For medical projects, see TM 5-838-2. ¹ For nonrepetitive facilities, concept design will be limited to no more than 25 percent of total design. For repetitive facilities, concept effort will consist of conceptual design of site development only and project cost estimate. |
| 3 | Authorized for preparation and submission of budget sketches, outline specifications, and cost estimates. Items so coded have been previously authorized for design in some instances with a different scope. Submission of budget drawings, specifications, and estimates is required to reflect current design even though scope of item has not changed. Concept design is also authorized as outlined under Code 2 above. |
| 4 | Design withheld pending issuance of a supplementary design directive. |
| 5 | Deferred from program. Do not start design. If concept or final design has already been started by District Engineer personnel, it will be terminated. If concept or final design is being accomplished by architect-engineer contract, it will be terminated or completed as will best serve the interests of the government. When the AE contract is not terminated, inform OCE, ATTN: ENGMC-CA, within 10 days with justification. |
| 6 | Authorized for final design. |
| 8 | Item cancelled, no longer a requirement. |
| 9 | Construction contract awarded since publication of last design annex. |

¹Medical Facilities Design-Army, TM 5-838-2 (Department of the Army, 6 April 1970).

APPENDIX G: FORMS AND REPORTS

MCA Project-Related Forms

Tables G1 through G5 list DOD, DA, Standard, Engineering, Savannah District, and Sacramento District forms related to MCA projects.

Periodic and Summary Reports

Tables G6 through G9 list annual, semi-annual, quarterly, and monthly reports respectively.

Table G1

Department of Defense (DD) Forms

DD Form	Title	Functions	Source	Recipient	Purpose
254	Security Req. Check Lists	Prior to E Contr. Closeout	AE	Dist	Classification Regs.
350	IPAR	Contract Awd.	Div	OCE	Ref: ASPR 21-100
541	Settlement Proposal- Total Cost Basis	Fixed Price Contr.	Dist	AE	Ref: ASPR 8-802.2
547	Settlement Proposal for Cost Reimbursement Contracts	AE Contract Terminations	Dist	AE	Ref: ASPR 8-803
548	Applic. for Partial Payments	Partial Perform. Payments	AE	DE	Reimbursement Ref: ER 335-345-1
813	Report of Cost and Analysis	CWE based on all Const. Contr. Awards	Dist	OCE	Ref: ER 335-345-1
879	Statement of Compliance	Contracting Certifications	Contractor	CO	
1195	Req. for Par. Pay.	See 547	Contractor	CO	Reimbursement
1270	Short Contract (Negotiated)	Contract Form	Contractor	CO	
1205 to 1220	Base Evaluation	Design Input; Site Characteristics	IC	PM	
1354	Tx & Acceptance of MRP	RP Inv.	IC	Records	Ref: ER 415-35-1
1376	FH Occupied by Mil Families	FH Survey	IC	Maj C	
1377	Current FH Conditions Report	FH Survey	IC	Maj C	
1378	Determination of Housing Req. and Project Composition	Projects LRFH Req/ Assets/Deficits/ No. and Types for Spec. Annual Proj.	IC		
1379	Narrative Summary for FH	Justifications and Major Missions of 1	IC	Maj C	
1390	FY MCP	Installation SRCP Summary	IC	Maj C OCE	

Table G1 (Cont'd)

DD Form	Title	Functions	Source	Recipient	Purpose
1391	MCP-Data	SRCP Description and Criteria Ea Project	IC	OCT	
1398	FH Proj. PR				
1413	Perform Eval. for Contr. Greater than \$10,000	AE Evaluation	DE(CO)	DE Contract (K) File	Ref: ASPR 18-403.4
1423	C. Data Req. List	Contracting	DE	Div	
1427	Notice Awd, Statement, etc.	As Req'd.	Dist	Maj C/ User/Div	
1501	Abstract of Bids	Bid Opening	CA Board	DE/Div	
1523	Mil FH Justif.	FH Need Develop	Maj C	DCSLOG	FH Requirements
1524	Request for Pre-award Contr. Survey	Eval. of Cr Capabilities	CO	Dist. Survey Group	Ref: ASPR 1-905.4
1535	Request for Advert. Approval	AE Selection	DE/Div E	Div E/OCE	
1539	Certif. of Appointment	Appointment Dist./Div. CO	DE or Div E	OCE	Ref: ASPR 18-
1586	Contract Funds Status Report	Contract Status	DE	Div E/OCE	
1592	Contract Cancellation	Contract Status	DE/Div E	OCE	
1596	Contract Perf. Eval. Report	Contract Status	DE/Div E	OCE	Ref: ASPR 18-106.2
1597	Contract Close Check List	Contract Status	DE	Div E/OCE	
1598	Contract Completion/Term Status	Contract Status	DE	Div E/OCE	
1638	Reported Excess Cr Inventory	CK Inv Control	CO	File	
1657	Determination of Bachelor Housing Requirements	Troop Housing Support	IC	Maj C	
1826	Certif. of Competency	Contracting Certification	Cr	CO	

Table G2

Department of the Army (DA) Forms

DA Form	Title	Functions	Source	Recipient	Purpose
12-25	Constr. Environment for:				
42-35	Nuclear Weapons Publications				
140	Manpower Summation				
726A	Coord. IRCP Instal., LRCP	MP-Annotated for 6 year per.			
1043	Manpower (Voucher)				
1709R	Bachelor Housing Capacities and Utilization		IC	Maj C	
1762	C Labor Stds	Control of Const. Phase	CO	PM	Statutory Requirements
2285R	Long-Range Analysis of C-I Functions	New Start Funds	Dist	Sec. of Army	Ref: AR 235-5
2368	BIS	MP, Phase 1	Fac E; IC	OCE	Ref: AR 210-20
2369R	Tab Xst/Reg. Fac. (LRCP)	0) LR Plng. 1) Instal. Status 2) Fac. Req.	IC	DE Maj C OCE	Ref: AR 210-20 Real Prop. Records LRCP
2529	AMC				
2530R	Comd SRCP	MP Implement	IC	OCE	Ref: AR 415-15
2605R 6 7 8	Work Est. Sheet Eq. Req. Sched. Eq. Assign. Sched. Eq. Status Report	TRADOC Calc.			Resources Allocations
2866	FH R Impr. Proj. Reports	FH Needs	IC	Maj C	Maints. of FH Stds
2788 1 2 3 4	FE Tech Data Summary Utilities Heating Bldg. & Grounds	Install. Monitoring	Fac E	IC	Ref: AR 420-16
2869-1 -2 -3	FE Util Anal-OP Data Utilization Prgm Narrative Review	Installation Monitoring	Fac E	IC	
2877	Real Prop. Record	RP Rec. Cord Source Data	Fac E	File	Ref: AR 735-27

Table G2 (Cont'd)

DA Form	Title	Functions	Source	Recipient	Purpose
3207	Cost. Anal. Work Sheet	Budget Analysis	Fac E	OCE/File	Fiscal Control (AR 235-5)
3491R	LR Projects - ARC	RC Planning	Dist	Chief, AR	
3640	DE 3641 Update				Ref: AR 210-20
3641	RP Assets	Fac. Data Card	Fac E	Records	Ref: AR 210-20
3896R	Report on Non-Ap Funded Constr.	Report in Accord. with Cost Level	Fac E	OCE	Officers' Clubs
3941	Certificate of Proficiency				
3965	Manpower Res. Review	In-House Capability	DE	Div	District Design Capabilities

Table G3

Standard and Engineering Forms

Eng Form	Title	Functions	Source	Recipient	Purpose
0-2519		OCE 1391 Review	OCE		
0-2729	D Directive, OCE		OCE	DE	
0-4375A	MCPR, Design	D Status	PM/User	OCE	Monitoring, Ref: ER 415-345-43
0-4376B	MCPR, Constr.	C Status	CO/PM	OCE	Monitoring, Ref: ER 415-345-43
90	CEOP/MCA				
93	Proj. Cost Estimate	Budgeting, Programming	IC/Dist	OCE	Fiscal Control
150	Contract Cost Est.	Funding			Ref: TM-5-800-2 ER 415-345-42
205	R Prop Inv. Update	Data for DA 3641	Instal.	Dist	
251	AE Listings	AE Pre-selection Prep.	Dist ADP Listings	AE Pre- selection Board	AE Selection
252	Fix Price Contract - AE	AE Contracting	Dist	AE/Dist	AE Design Implementation
527	CE Lease Form	Gov. Lease Agreement	Div E or DE	OCE	Ref: ER 405-1-1020
856	CE Land Lease	Gov. Lease Agreement	Div E or DE	OCE	Ref: ER 405-1-1020
1064	RE Acq	Site Acq	IC	Maj C	

Table G3 (Cont'd)

Eng Form	Title	Functions	Source	Recipient	Purpose
1069	Docket Sheet (field)	Source Record for Data for Eng F 3376		Div E	Ref: ER 405-1-1017
1523-R	DA Lease for Industrial Fac	DA Lease	DA	OCE	Ref: ER-405-1-103
1619	Plant and Equipment Schedule	Plant Desc.	AE	Dist	Ref: ER 1180-1-1 App. A
2180	Contr. Nego. Record	AE Contr.	Dist	Div PM	Statutory Requirement
2180A	Contractor Data	AE Contract	AE	PM	
2459	Preaward Survey	AE/Const. Contracts Preaward Survey	Dist	Div	
3018a, b, c	Budget Summary R	FY Cost Report (Quarterly)	Dist	OCE	Ref: ER 37-345-10; OCE Prog. Review/Analysis
3031	MC Progm & Cost R		Dist	Div/OCE	Ref: ER 37-345-10
3086	CWE	OCE Rpts. to Congr. Support	Dist	OCE	Budget Purposes
3132-R	Adv Notice to Bidders	Info. on Projects	Dist	AE	Ref: ECI 2-203.1
3133-R	Adv Notice to Bidders Mail Wrapper	Request Card for Info.	AE	Dist	Ref: ECI 2-203.1
3342-R	Open End Lump Sum Contr.		Dist	AE	Ref: ER 1180-1-1 App. A
3423	Negotiator's Report	Source Record for data for Eng F 3376		Div E	Ref: ER 405-1-1017
3452	Contract No. Register	Rec. and Register Contract Doc.	Dist	Dist	
3453	Contract Modification Rec.	Rec. and Register Contract Doc.	Dist	Dist	
3454	Contract Mod. Register	Rec. and Register Contract Doc.	Dist	Dist	
3455	Purchase Order No. Register	Rec. & Register	Dist	Dist	
3456	Invitation Bids Register	Rec. & Register Contract Doc.	Dist	Dist	
3634	Announce of Contr. Awards	Base summary	IC	OCE	Ref: ER 415-345-39
3645-R	Fiscal Yr. Const. Executive Programming Sched.	Direct Funding from MCA Appropriation	Div E or DE	OCE	Ref: ER 415-35-1

Table G3 (Cont'd)

Eng Form	Title	Functions	Source	Recipient	Purpose
3705	Addendum to DDF813	Rpt. Desc. Data and CWE on Const. Contr. Award	DE	OCE	OCE Records Ref: 1 R 335-345-1
3726	Official Contr. Records Check List	Reflects Req. Doc. at Initiation of Contr.	Dist	AE	Ref: 1 R 1180-1-2
3938	C Mod and Acceptance	Pricing of Contract Chg	Contractor	CO	Ref: 1 P 415-1-260
4376	C Records Check List		OCE	User	
4377	Transept. to MCPR	Functional to Punch Cards for Master File Storage	CO/OCE	OCE/User/Div	Ref: 1 R 415-345-43
4477-R	Leased and Allocated Space Punch Card Format	Rpts. Mod., Deleted or New Leases	Div E or DE	OCE	Ref: 1 R 405-1-1020
Std Form	Title	Functions	Source	Recipient	Purpose
2	Gov. Lease for RP	Full Part Time Leasehold Int.	DE	OCE	Ref: 1 R 405-1-1020
2A	Gov. Lease for RP	Full Part Time Leasehold Int.	DE	OCE	Ref: 1 R 405-1-1020
2B	Gov. Lease for RP	Full Part Time Leasehold Int.	DE	OCE	Ref: 1 R 405-1-1020
19	Invit/Bid/Award	Right to Issue Contr. Mod. Less than \$10,000	OCE	Resident CO	
23	Constr. Contract	Right to Issue Contr. Mod. Less than \$10,000	OCE	Resident CO	
30	Amend of Solicitation				
33	Solicitation Offer/Awd				
34	Bid Bond Certif.				
35	Perf. Bond Certif.				
251	AE Listings and Qual. Summary	AE Questionnaire	AE	Div	Ref: ASPR 18-403.4
252	AE Fixed Price Contract	Open-End Contract for 1 year AE Svc	Dist	AE	Ref: 1 R 1180-1-1 App. A
1034	CPFF Contract	Public Voucher for Purchase or Service	Dist	AE	
1143	Advertise-Order Public Voucher				

Table G4

Savannah District Forms

Form ID	Title	Function	Source	Recipient	Purpose
SASVE Form No.					
20	C Complete Data Sheet	Constr. Contract	Constr. P.	File	Legal Rec.
141	Distrib. List for Specs.	Bid Pack Develop.	PM	Specs. Br.	Bidding Progress
267A	Compl. Chart - Arch.	Design Calc. Records	AE	PM	Design Analysis
267B	Comp. Chart - Engrs.	Constr. Plan Calc.	District Engr. Div.	PM	Plng Analysis
337	Comment M. Proj. Sched.	MP Sched.	IC		
337I	MP	MP Revision	IPB/Dist	DE	SRCP Development
337G	Detail Site Plane	MP Revisions	IPB/Dist	DE	SRCP Development
376	Distr. List Mod.				
513	C Action & Distr. Record	C Awd Notification	C Awd Board	PM Div/User	Legal Record and Notification
519	Mo PR	Design	Dist	Div/OCE	Functional
693 - b d f	CWE-MCP: Design Funds MP Constr. Funds Mgt & Engr.	ADP Systems	District: Budget & Reports Section	PM	Fiscal Control
714a	AE Qualif. Data	ADP Record	Dist	Div	Legal Record
715	Project Rev. Comments	Procedural Review; Plans Update	Dist or Div	OCE	Planning Update
719	AE Design Checklist	District Review	AE	PM	Design Checkout
727	Checklist Review of AE Design	CDR	AE	PM	Design Checkout
727a	727 Follow-On				
734	Transmittal List of Final Proj. Tech. Specs, Drwgs. & Misc. Provisions	Doc. Control	CO	K. File	
745	Arch-Engr. Selec. Action	AE Selection Board Meeting	CO	Div E	
812	Awarded Line Item Record	Contracting	CO	R File	

Table G4 (Cont'd)

Form ID	Title	Functions	Source	Recipient	Purpose
814a	Architect-Engineer Checklist	AE Contract	CO	R File	
845	Property Accountability (ADP)	RP Control	CO	R File	
850	Mil. Constr. Pro. Cost Control Sys. Design & Support Allotments	Budget Control	CO	K File	
878	Value Engineering Program - Cost Control	Construction Cost Control	CO	OCE	
890	Data for Advance Notice & Contract Time	Contracting	CO	K File	
905	Arch-Engr. Contract Fund Document	AE Contracting	CO	K File	
944	Supporting Data for Request for Design Funds	Design Funding	CO	OCE	
971	Review and Analysis Performance Data	Cr Performance	CO	K File	
991	Current Military Projects Schedule	MCA Proj. Summary	DE	OCE	
995	Record of Authorized Military Const. Program	Mgt. Control	DE	K File	
1018	Gov. Estimate of Reasonable Contract Cost for Modification	Contract Change	CO	Nego.	
1021	Value Engrg. Proposal - Short Form	See 878			
1039	Use of Weighted Guidelines in Connection with Determining Fair and Reasonable Profit for Fixed Price Constr.	Contracting	CO	K File	
1047	Contract Mod. Control Card	K Change	CD	Nego.	
1048	Construction Evaluation				
1049	Environmental Evaluation Checklist	Environ. Control	PM	OCE K File	

Table G5

Sacramento District MCA Forms

SPK Form	Title	Function	Source	Recipient	Purpose
48	ADP Production Request Control	Monitoring	DE	DE/Nego.	Mgt.
62	AE Selection Criteria Card	AE Negotiations	Sel. Bd.	DE/Nego.	Coord.
84	Request for Approval of Contract Mod. and Overruns	Tech Review	CO	Div/OCE	Fiscal
88	Req. for Clearance for Access to Class. Mat.	Security Control			Statute
91	Transm. of (Prelim) (Final) Plans and Spec for Review & Comment	Tech Review	AE/PM	PM/User	Control
118	Monthly Mil Design Project Schedule	Design Br. Scheduling	AE	PM	Mgt.
150	AE Selection Bd Questionnaire for AE Interview	AE Selection	AE	Sel. Bd.	Verification of SF 251
151	AE Eval. Sheet	AE Selection	Sel. Bd.	DE	In-House Record
161	Mil Job Data Sheet	Project Definition	PM	AE/Design	Coord.
265	Change Order Mod. Plan	Tech Review	PM	DE/User	Coord.
260	Military Design Schedule	Planning	PM	DE/User	Coord.
285 285 a, b	"AE Selection Memo of Record"	AE Information; Preselection (a); Selection (b);	Preselect. and Sel. Bids	CO	Ref: ER 1180-1-1
321	Gen Purpose Data Form	Tech Review	Reviewer	PM	
344	Quarterly Sum'ry-Mil. Design Costs	Budget Control	Budget S	CO	Fiscal Control
351	Status of Constr. Contract Changes	Tech Mgt.	DE	Div	Mgt. Control
357	A-E Performance Evaluation - Worksheet Summary	Performance Records	PM	CO	Statutory Requirement
357A	AE Perform. Eval. for Constr.	Perf. Records	PM	CO	Statutory Requirement

Table G5 (Cont'd)

SPK Form	Title	Function	Source	Recipient	Purpose
362	Engr Review Com	CDR	PM	Design	Record
475	Back-Up Data to (AE Proposal) (Gov. Est.)	AE Nego Bids Eval.	Nego		Record/Nego.
475A	Back-Up Data to (AE Proposal) (Gov. Est.)	AE Nego Bids Eval.	Nego		Record/Nego.
476	Sample Format for Back-Up Data to AE Proposal	AE Nego	Nego		Record/Nego.
476a	Sample Format Back-Up Data to AE Proposal	AE Nego	Nego		Record/Nego.

Table G6

Annual Reports

Form	Title	Function	Source	Recipient	Purpose
ENG 3376	S of RE Acq.	Reports RE Acq.	Dist/Div	OCE	Ref: ER 405-1-1017
DA 4147R	Gen Officer's Qtr's Cost Report	Budget Control	IC	OCE	Ref: AR 210-50
	Summary of Negotiated Cnst Contracts and Mod.	Report all Contracts	DA/Div	OCE	Ref: AR 415-1
ENG 90	CEOP	CE Annual Operations Schedule	OCE		
	RPI of Exchange Facilities	Real Property Control	OCE		
	Study of Const. Projects - One Two Step Proc.	Procedures Control	Div/Dist		Ref: Ltr ENGMC/F 29 Sep 70.
	AF Cnst Progress Report	AF Programs Monitoring	Field Ofc. AFC		Ref: Ltr ENGMC-CF 31 Aug 70.
	Report of Site Adaptable Designs	Methods Eval.	Field. Ofc. OCE		Ref: EC 415-3-9
	Real Estate Program Schedule		Div/Dist OCE		Ref: ER 405-1-1009
	Current Design	Methods Eval.	Field Ofc.	OCE	Ref: ER 1110-345-101
DD 1905	Priority Improve- ment Projects	Planning Update	Maj C	OCE	Ref: AR 5-4

Table G6 (Cont'd)

Form	Title	Function	Source	Recipient	Purpose
DA 4133	Mgt. Review and Improvement Information	Mgt. Improvement (MI)	Maj C	OCE	Ref: AR 5-4
DA 4134	Recommend. for MI Awd.	MI	Maj C	OCE	Ref: AR 5-4

Table G7**Semiannual Reports**

Form	Title	Function	Source	Recipient	Purpose
DD 1410	Inventory and Occupancy of Mil Owned and Controlled FH Units	FH Install'n Survey Summaries	IC	Maj C	Ref: AR 210-50
DA 2576-R	Personnel Occupying Army FH	FH Survey	IC	Maj C	Ref: AR 210-50
	Procurement of Options in Adv of Auth to Acq Real Prop	Real Prop.	OCE	Congress	
	Report of Surplus Real Prop. Disposals and Inventory	RPI Control	Div/Dist		Ref: ER 405-1-1040
DA 4133	Mgt. Review & Improv. Info	MI	Maj C	OCE	Ref: AR 5-4
DA 4135	Mgt. Improve. Act	MI	Maj C	OCE	Ref: AR 5-4
DA 4136	Mgt. Improve. Area Summary	MI	Maj C	OCE	Ref: AR 5-4

Table G8
Quarterly Reports

Form	Title	Function	Source	Recipient	Purpose
ENG 2440	Real Estate Acq and Possessions Progress Report		DA	OCE	Ref: ER 405-1-1015
ENG 3645-R	Cnst. Execution Program Sched.	Prepare and Revise Annual Funding Plans	Div E/DE	OCE	Ref: ER 415-35-1
ENG 4186	Report of AE Contract Awards	Summation of these Forms	Div	OCE	Ref: ECI 75-203
ENG 4477	Lease or Allocated Space Punch Card Format	Report Modified, Selected a New Lease			Ref: ER 405-1-1020
DA 2541	Install Inventory of Mil RP & Bldg Info Schedule	RPI Summary for Install within US	IC	OCE	Ref: AR 405-45
	Report of All AE Contracts More than \$25K	Contractual Report	Fld Ofc.	OCE	Ref: ASPR 18-404.1
	Q Report of AE Contract Awards More than \$100K	Summary of All AE Contract Awards	OCE	OSD	Ref: ASPR 18-404.2
	RE Transactions	PPI Control	OCE	Congress	
	DOD Reserve - Forces Facilities; Maj Const Program	Monitoring of CE Construction RC Fac	OCE	Chief of AR OSD	
	Ltr Contracts Awd - Definitized and Outstanding		All Fld OCE		Ref: ECI-6-408.50

Table G9
Monthly Reports

Form	Title	Function	Source	Recipient	Purpose
ENG 3632 ENG 3633	Design & Cnst Prog. Reports	Current List of Report Records	Dist	OCE	Ref: ER 415-345-43
ENG 4377	Mil Cnst Progress Reports	Contain Info on Funding, Planning, Other	Dist/Div	OCE	Ref: ER 415-345-43
DD 1057	Monthly Procurement Summary	Summary of Actions Less than \$10K	DOD	OCE	Ref: ASPR 21-200
	Progress Narrative Report (Semi-Monthly)		Div	OCE	Ref: Ltr DAEN-MCE-G, 30 Apr 73

CERL DISTRIBUTION

Chief of Engineers
ATTN: DAEN-MCZ-S (2)
ATTN: DAEN-ASI-L
ATTN: DAEN-MCC-E
ATTN: DAEN-MCE-D
ATTN: DAEN-RDL
ATTN: DAEN-CWZ-R (3)
ATTN: DAEN-CWR-R (2)
ATTN: DAEN-ZCP
ATTN: DAEN-MCP (3)
ATTN: DAEN-FEM
Dept of the Army
WASH DC 20314

The Engineering School
Technical Information Br
Archives Section (Bldg 270)
Ft Belvoir, VA 22060

USA Engineering School
ATTN: ATSEN-DT-LD (2)
Ft Belvoir, VA 22060

Director
USA Cold Regions Research
Engineering Laboratory
PO Box 282
Hanover, NH 03755

Director, USA-WES
ATTN: Library
PO Box 631
Vicksburg, MS 39181

Deputy Chief of Staff
for Logistics
US Army, The Pentagon
WASH DC 20310

The Army Library (ANRAL-P)
ATTN: Army Studies Section
Room 1A534, The Pentagon
WASH DC 20310

Commander
U.S. Army Foreign Science &
Technology Center
220 7th St, NE
Charlottesville, VA 22901

Commander
U.S. Army Science & Technology
Information Team - Europe
APO New York, 09710

Commander
U.S. Army Science & Technology
Center - Far East Office
APO San Francisco 96328

Engineer
US Army, Alaska
APO Seattle, WA 98749

Commanding General
US Army Forces Command
ATTN: AFEN-CDC
Ft McPherson, GA 30330

Defense Logistics Studies Infor-
mation Exchange (2)
U.S. Army Logistics Management
Center
ATTN: AMxMC-D
Ft Lee, VA 23801

Each MC Division Engineer
US Army Engr Div
ATTN: Library
ATTN: Chief, Engr Div

Each MC District Engineer
US Army Engr District
ATTN: Library
ATTN: Chief, Engr Div

USA Engineer Dist, Kansas City
Military Branch
ATTN: Project Manager
ATTN: Section Chief
Design Branch
ATTN: Project Manager
ATTN: Section Chief
601 East 12th Street
Kansas City, MO 64106

USA Engineer Dist, Omaha
Military Branch
ATTN: Project Manager
ATTN: Section Chief
Design Branch
ATTN: Project Manager
ATTN: Section Chief
215 North 17th Street
Omaha, NB 68102

USA Engineer Dist, Alaska
Military Branch
ATTN: Project Manager
ATTN: Section Chief
Design Branch
ATTN: Project Manager
ATTN: Section Chief
P.O. Box 7002
Anchorage, AK 99501

USA Engineer Dist, Savannah
Military Branch
ATTN: Project Manager
ATTN: Section Chief
Design Branch
ATTN: Project Manager
ATTN: Section Chief
P.O. Box 889
Savannah, GA 31402

USA Engineer Dist, Sacramento
Military Branch
ATTN: Project Manager
ATTN: Section Chief
Design Branch
ATTN: Project Manager
ATTN: Section Chief
650 Capitol Mall
Sacramento, CA 95814

USA Engineer Dist, Fort Worth
Military Branch
ATTN: Project Manager
ATTN: Section Chief
Design Branch
ATTN: Project Manager
ATTN: Section Chief
P.O. Box 17300
Fort Worth, TX 76102

Commander
US Army Development
and Readiness Command
ATTN: DRCIS-M
5001 Eisenhower Ave
Alexandria, VA 22304

Commander
USA Training & Doctrine
Command
ATTN: ATEN-C-C
Ft Monroe, VA 23651

Commander
USA Military Dist of WASH
ATTN: ANEN-PP
WASH DC 20315

Commander
USA Europe and Seventh Army
ATTN: AEAEN-C
APO New York 09403

Commander
USA Japan
ATTN: AJEN-MC
APO San Francisco 96343

Commander
Eighth USA
ATTN: ENJ-P&O
APO San Francisco 96301

Commander
USA Ballistic Missile Defense
Systems Command
PO Box 1500, West Station
ATTN: BMDCS-RC
Huntsville, AL 35807

Commander
USA Security Agency
ATTN: IALOG-IC
Arlington Hall Station
Arlington, VA 22212

Commander
US Army Communications Command
ATTN: SCC-ENGR-CP
Ft Huachuca, AZ 85613

Commander
USA Health Services Command
ATTN: HSC-LO-F
Ft Sam Houston, TX 78234

Commander
USA Military Traffic Management
Command
ATTN: MTMC-SVI-SPI
WASH DC 20315

Commander
USA Criminal Investigation Command
ATTN: CILO-LM
WASH DC 20318

Officer in Charge
Naval Civil Engineering Lab
Port Hueneme, CA 93043

AF Civil Engr Center/PG
Tyndall AFB, FL 32401

AFWL/Civil Engr Div
Kirtland AFB, NM 87117

AF/PREE
Bolling AFB, DC 20332

Air Force Weapons Lab
ATTN: DOUL
ATTN: DE
Kirtland AFB, NM 87117

Defense Documentation Center
ATTN: TCA (12)
Cameron Station
Alexandria, VA 22314

Library of Congress (2)
Exchange and Gift Div
ATTN: American and British
WASH DC 20540

Superintendent of Documents
Div of Public Documents
ATTN: Library (2)
US Govt Printing Office
WASH DC 20402

Bldg Research Advisory Board
National Academy of Sciences
2101 Constitution Avenue
WASH DC 20418

Institute of Defense Analysis
400 Army-Navy Drive
Arlington, VA 22202

Engineering Societies Library
345 East 47th Street
New York, NY 10017