

AD-A033 374

ROYAL AIRCRAFT ESTABLISHMENT FARNBOROUGH (ENGLAND)  
AN ADAPTATION OF THE ICL GEORGE 3 AND 4 MARK 8 CORRECTION SYSTEM--ETC(U)  
MAY 76 F J SMITHIN

F/G 9/2

UNCLASSIFIED

RAE-TM-MATH-7603

DRIC-BR-53324

NL

1 of 1  
ADA033374



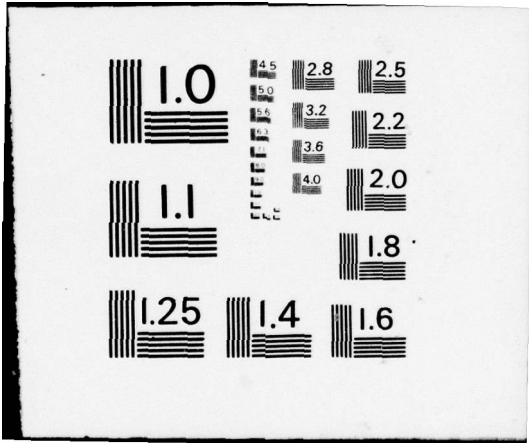

BR53324

TECH. MEMO  
MATH 7603

UNLIMITED

TECH. MEMO  
MATH 7603



ROYAL AIRCRAFT ESTABLISHMENT

ADA033374

AN ADAPTATION OF THE ICL GEORGE 3 AND 4 MARK 8  
CORRECTION SYSTEM TO SATISFY THE RAE'S  
REQUIREMENTS ON ITS 1906S PROCESSOR

by

F. J. Smithin

May 1976

DISTRIBUTION STATEMENT A  
Approved for public release  
Distribution Unlimited

DDC  
RECEIVED  
DEC 2 1976  
D

© Crown copyright 1976

COPYRIGHT ©

CONTROLLER HMSO LONDON

1976

White Section	<input checked="" type="checkbox"/>
Buff Section	<input type="checkbox"/>
ANNOUNCED	<input type="checkbox"/>
UNANNOUNCED	<input type="checkbox"/>
CLASSIFICATION	
SECURITY CLASSIFICATION CODES	
RELEASING OFFICE	
RELEASING OFFICE	

A

14 RAE-TM-Math-7603

ROYAL AIRCRAFT ESTABLISHMENT

9 Technical Memorandum, Math 7603

Received for printing 18 May 1976

6 AN ADAPTATION OF THE ICL GEORGE 3 AND 4 MARK 8 CORRECTION SYSTEM TO SATISFY THE RAE'S REQUIREMENTS ON ITS 1906S PROCESSOR.

by

18 DRIC

10 F. J. Smithin

11 May 76

19 BR-53324

12 3pp.

SUMMARY

A new method of making changes to the George Operating System was adopted by ICL when Mark 8 was released. The correction system offered by the manufacturer did not completely meet the RAE requirement and a modified system has been introduced. This Memorandum describes the correction system and RAE's implementation to enable 'in-house' development work to proceed in parallel with published changes to the system.

DDC  
 RECEIVED  
 DEC 2 1976  
 RECEIVED  
 D

310 450  
 LB

CONTENTS

	<u>Page</u>
1 INTRODUCTION	3
2 THE NEW SYSTEM	4
3 ITEMS RECEIVED FROM ICL	4
4 HOW TO CORRECT GEORGE	5
5 ORGANISATION OF FILESTORE TO UPDATE GEORGE	6
5.1 Format of entrant names	7
5.2 The update macro G4UPDATE	7
5.3 Procedure for updating the George source code	8
6 COMPILING GEORGE	9
6.1 Procedure in the event of an error in compilation	11
7 NON-STANDARD VERSIONS OF GEORGE	11
7.1 Compiling non-standard versions	11
8 SETTING UP SUBSEQUENT ISSUES OF MARK 8	12
9 CONCLUSIONS	14
Acknowledgment	14
Appendix A Specifications of non-ICL GIN compilation macros	15
Appendix B Example of a software correction	16
Illustrations - Figures B1 and B2	18
References	25
Illustrations	Figures 1-3

1     INTRODUCTION

The central computer installation at the Royal Aircraft Establishment comprises two main frame computers of International Computers Limited 1900 series; a 1906S and a 1904A. The 1906S processor was until recently operating under the George 3 Mark 7.7 operating system but owing to the introduction of an improved version, known as Mark 8, the manufacturer has progressively withdrawn his support of the earlier system. The new mark of George was introduced at the RAE on 3 February 1975. Subsequently the George 4 paged operating system was implemented and it is the Mark 8 version of this which is currently in use on the 1906S.

A major difference between the two marks of operating systems is the method adopted for incorporating the changes promulgated by ICL. Under the Mark 7 system, a change to the 'source' code (the form in which the operating system is originally written) necessitated a complete re-compilation. Any intermediate changes took the form of 'alters' or 'mends' to the system and a permanent change was effected by an edit to the source version to produce a later mark.

The new method adopted by ICL for Mark 8 enables installations to make changes to the source code which can easily be incorporated into existing and future issues. The new approach provides for immediate and permanent changes to the source code as opposed to the two-level system under Mark 7.

To implement the new correction system, as proposed by ICL, would have placed severe limitations on the manner in which local improvements to the operating system were developed, and so a modified system has been introduced which enables George software to be developed alongside the published changes.

This Memorandum describes the manner in which the author has implemented the Mark 8 correction system so that development work on test compilations can continue alongside the operational system.

The first issue of Mark 8 was known as Mark 8.10. Subsequent issues, which can be defined as the release of a complete version of George by the manufacturer, contain major enhancements and are known as 8.20, 8.30 and so on. Intermediate issues which are necessary to overcome errors detected by users will be numbered 8.11, 8.12, 8.21, etc. The initial Mark 8 version implemented at the RAE was 8.12.

## 2 THE NEW SYSTEM

It is convenient to describe briefly the new system to appreciate the organisation set up in the filestore. The magnetic tapes supplied by the manufacturer contain not only a compilation of George in machine code (known as a 'dump' version) but also the source code version of the George chapters. 'Source' denotes the version of a program as written by a programmer prior to compilation to machine code, and in this context the George source language is GIN and a chapter is the smallest unit of compilable code. As a further service, corrections to 'bugs' (errors) are made available by ICL, which can be introduced to suit a user's particular installation, and will take the form of an edit to chapters in the source code.

When a chapter of George requires editing, a 'sub-file' containing the chapter is copied into the filestore from magnetic tape and is then edited using the George editor according to the correction which has been notified. The dumped compilation of George which is being updated is then started and the edited chapter is compiled and inserted in place of the earlier version of the same chapter. No other chapter is recompiled although any number of chapters may be brought into the filestore, edited and recompiled at the same time. If the edits to a chapter increase the size of the chapter when rounded-up to a multiple of 128 words, it is placed at the end of the chapter file. This means that the chapter file will steadily grow as more corrections are applied.

The manner by which an installation organise its updating system will depend upon the capacity available and its requirements. In Ref.1 a system of updating is described which allows the user to make progressive changes according to the published edits supplied in software notices (one means by which ICL promulgates information on edits). At the RAE there is also a requirement to make changes to satisfy needs which are local to the site. This means that a facility is needed within the updating system to enable experimental compilations to be produced for testing before making them available to the operational system. The system must be so organised that these local requirements do not interfere with the general edits supplied by the manufacturer.

## 3 ITEMS RECEIVED FROM ICL

The George source is supplied on the ICLKG3CHAPS or ICLKG4CHAPS tape for George 3 and 4 respectively. The sub-files on this tape are:

(a) The version definition file (VDF)

The VDF is an index of the source sub-files in this version of George. Not all the chapters quoted in the VDF are necessarily compiled into the accompanying dump of George. Some will apply only to George 3 and others to George 4. Also some sub-files recorded in the VDF are not necessarily on the source tape.

(b) Source

The partial source sub-file is a composite file containing the source of the George chapters. Certain sub-files like macro definitions have been omitted to save space on the tape since these will not be required for correction purposes. Each chapter has its own sub-file, the name being that of the chapter or a concatenation of the chapter name and the version number (e.g. IPBMOP or IPBMOP8). To allow for successive corrections to any one chapter, a file generation number is also recorded in the sub-file and should be used when copying the chapter into filestore.

To facilitate the editing of chapters, two words of code (red tape words) have been introduced before the source record proper. The first word is a four-character key to the source line. The second word is reserved for internal development.

Another change, which will concern staff who have to implement new compilations of George, is that a control record is appended to each file containing a checksum of the source code. This checksum which is provided with each edit, is used to validate a new compilation of a chapter and to check that edits have been correctly incorporated. If an installation inserts its own changes into a chapter then the checksum will be invalid and should be ignored when compiling (see Appendix B).

The dump which is issued with a new mark of George is supplied on the ICLKG3SYSTEM or ICLKG4SYSTEM tape depending on whether the installation uses the George 3 or George 4 operating system.

4 HOW TO CORRECT GEORGE

Once the operating system has been loaded in the usual way<sup>1</sup>, the method of correcting George can be stated in simple terms as:

- (a) read the relevant chapter, referred to in the ICL software notice, into the George filestore;

- (b) implement the correction edit provided;
- (c) compile the new source chapter into George.

The preferred method for compiling a new source is to compile it directly from the filestore. If the chapters involved are updated generations of existing chapters then the George chapter table will be updated so that the latest generation is always used. The binary code of the new chapter will overwrite the previous chapter generation if its length does not exceed the previous generation (rounded-up to a multiple of 128 words) otherwise the new chapter is added to the end of the George program file.

Once the corrected source is compiled it is then dumped so that it can be used as a source for further changes, with no need to repeat those changes already implemented.

It becomes clear from the foregoing paragraphs that the local computer management should establish controlled procedures from the outset so that the requirements of the Mark 8 correction system are applied.

#### 5 ORGANISATION OF FILESTORE TO UPDATE GEORGE

To facilitate the correction system it is necessary to create a mini-structure within the filestore. For those readers who are not familiar with ICL's system, a brief description of the filestore hierarchy is given.

The George filestore is a tree structure which comprises a number of users and each user has a directory which refers to all the files owned by that user. A filestore file is a set of data which can be identified by name and which is referred to in a directory. The most senior user is known as :MASTER and this contains two directories known as :MANAGER and :SYSTEM. The user structure below :MANAGER reflects all the users in the RAE divided into their respective departments and divisions according to the Establishment's departmental cost numbers. It is the RAE's convention<sup>3</sup> to make the directory names the same as the user names, that is without the colon prefix. :SYSTEM has subordinate directories which contain system information grouped according to function. This information is managed by the computing staff.

Another facility which is provided by the operating system is the ability to create pseudo-users, so named because they have none of the rights that can be exercised by their superior users. This offers a convenient means of grouping together and manipulating files related to a particular function without having to set up new 'proper' users.

To enable updating and corrections to the operating system to be maintained in an orderly fashion and also to allow development to proceed without hindrance, it is necessary to set up a new user under :SYSTEM and to exploit the pseudo-user facility. The new user has been given the name :GEORGE and six pseudo-users have been created with the following classification:

- :MK8ab            Contains chapter source files (including chapters updated by ICL edits);
- :MK8abMENDS    All chapters with RAE edits incorporated and tested, and pure RAE chapters;
- :MK8abTEST     Contains all mended chapters under development;
- :MK8abPARAM    Contains compilation parameter files;
- :MK8abEDITS    Contains the edit files of amendments awaiting to be implemented;
- :MK8abOLDED    Contains edits which have been implemented;

where 8ab is the mark of George; in RAE's case it is currently 8.12.

#### 5.1 Format of entrant names

The chapter files in pseudo directories :MK8ab, :MK8abEDITS and :MK8abTEST are known by chapter name vn (fgn) where vn is the version number and fgn is the generation number. For example in IPBMOP8(2), the version number is 8 and the file generation number is 2. In pseudo directory :MK8abTEST the file generation number is not significant.

The edit files in :MK8abEDITS and :MK8abOLDED have the format:

chapter name vn (old fgn/TO new fgn)

where vn        = version number

      oldfgn = existing generation number of the chapter file

      newfgn = new generation number of the chapter file

The edit files should contain editing instructions for the chapter to be amended and should be followed by

S.W. nnnn - 'message'

to describe the mend, where nnnn = software notice number and 'message' is a brief description of the mend.

#### 5.2 The update macro G4UPDATE

To facilitate the implementation of the ICL correction edits, a macro, which is a file containing one or more commands of the George command language,

has been written and is called G4UPDATE. It enables a complex set of George functions to be issued by a single command. Its functions are illustrated in Fig.1 and its purpose is to update any chapters referred to by software notices as follows:

- (a) to edit ICL source chapters to produce an updated version;
- (b) chapters which have been subjected to non-ICL mends are compared with the new ICL version and also updated. This applies to files in :MK8abMENDS and :MK8abTEST;
- (c) to set up restore directives in :MK8abPARAM.NEWSOURCE so that the corrected chapters can be compiled.

The format of a record in the NEWSOURCE file is

```
MENDIN } chapter name, version, newfgn
MENDINC }
```

where MENDIN is a macro which is used to compile ICL mended chapters and MENDINC is a macro to compile chapters from :MK8abMENDS (see Appendix A).

A file called TOTALSOURCE is also created in :MK8abPARAM which contains a record for every chapter updated by ICL edits since the George issue. The record format is

```
MENDIN chapter name, version, newfgn
```

A MENDREPORT stored in :MK8abOLDED is used as a database of mend information for every mend since the George issue. It comprises a summary of all software notices actioned in the next or previous compilations.

The format of a G4UPDATE call is

```
G4UPDATE Chapter name and version number, old file generation number, new
file generation number.
```

### 5.3 Procedure for updating the George source code

The procedure for updating a chapter of the George source code from a published software notice may be summarised as follows:

- (a) punch the edit onto cards or direct into filestore. Do not include the steering line which commences with ! which is used in the ICL correction system;

- (b) the name of the file is found in the edit line  
ED CHAP1(n), CHAP1(m)

and is input as

```
IN :GEORGE.:MK8nnEDITS.CHAP1(n/TOm)
```

- (c) a chapter is updated by running the macro  
G4UPDATE chapter name, oldfgn, newfgn

The update macro has to be repeated for each new chapter, changing the parameter as appropriate.

- (d) When all the edits have been completed, the compilation phase can be entered (see section 6).

An example of this procedure is given in Appendix B.

## 6 COMPILING GEORGE

A macro known as COMP-G48ab, where 8ab is the mark and issue number of the operating system in use, has been written to compile a new version of 'George'. A diagrammatic representation of its function is illustrated at Fig.2. This macro which is run in the :GEORGE directory has three parameters, all of which are optional.

- %A - provides an additional identification to the output file G4MK8ab%A LIST. The parameter is not normally used when compiling new George versions for operational use.
- \*WORK#csn - these parameters overwrite the default settings of the cartridge serial numbers on which a workfile and a progfile are opened as scratch areas. The default settings are:
- \*PROG#csn
- are: \*WORK#300013  
\*PROG#300011

A number of files from two pseudo directories :MK8abPARAM and :MK8abEDITS are combined to form the parameter file or GIN compilation pack which is used to produce the compilation. The files contain GIN code (the source language of George) and their contents are described in Table 1.

Table 1  
George 4 compilation macros

Pseudo-directory	File	Contents
MK8abPARAM	START	General GIN directives (see Ref.1).
MK8abPARAM	NEWMACROS	Non-ICL macro definitions (e.g. MENDIN, MENDING).
MK8abPARAM	NEWMACROS	ICL macro definitions not included in standard compilations.
MK8abPARAM	NEWMENDS	ICL issued mends for fixed core changes to George.
MK8abPARAM	NEWSOURCE	Chapters to be recompiled.
MK8abPARAM	MENDS	Standard restore time macros (e.g. FORBID, CHANGE).
MK8abPARAM	DUMP	Standard dump commands.
MK8abPARAM	END	Termination directives.

The GIN parameter file is created as a work file and an exofile is opened as program file (\*DAØ). The macro selects the latest generation of George from the magnetic tape G4MK8abDUMP(-0) and recompiles a new version to the next file generation using program XKOF. Three versions are maintained throughout and when a new compilation is generated, the G4MK8abDUMP(-3) is erased and returned to the pool. Output is sent to a lineprinter file G4MK8ab%A LIST, where the value of the parameter %A is usually unset for operational compilations.

To maintain a complete record of amendments

```
:MK8abPARAMS.NEWMACROS is appended to :MK8abPARAMS.STDMACROS
:MK8abPARAMS.NEWMENDS is appended to :MK8abPARAMS.NEWSTMENDS
:MK8abEDITS.NEWMACROS is appended to :MK8abEDITS.STDMACROS
```

thus all non-ICL macro definitions, all ICL macro definitions not contained in the issued version and all mends included since the issued version are readily available for reference.

The files NEWMACROS (2 off), NEWMENDS and NEWSOURCE are erased at the end of a successful compilation.

### 6.1 Procedure in the event of an error in compilation

In the event that either a chapter will not compile or that after compilation the mends are proved to be faulty 'George' will have to be recompiled.

If a chapter will not compile, then the NEWSOURCE file will need editing, the offending MENDIN record removed and a valid record substituted. In the case of chapters found to contain errors then a MENDIN statement referring to a correct version of the chapter can be inserted in the NEWSOURCE file for compilation.

### 7 NON-STANDARD VERSIONS OF GEORGE

At the RAE there is a requirement to develop non-standard chapters; this is a practice adopted by many installations to enable the local management to implement enhancements which are not necessarily suitable for general introduction. An example at Farnborough is the flexible list directory command which enables users to select groups of files from a directory and which outputs the file records onto a single line.

The edit system caters for development work of this nature as follows. Any George chapters which require modification are edited and stored in :MK8abTEST. A letter is then given to each development (say A) which will define a particular area of work in progress.

#### 7.1 Compiling non-standard versions

A functional representation of COMP-G4MK8ab is shown at Fig.3. The parameters are as follows:

- %A (mandatory) - a letter, used to identify an area of development. If it is omitted the compilation will fail.
- \*WORK csn (optional) - these parameters overwrite the default settings
- \*PROG csn (optional) of the cartridge serial numbers on which a workfile and a progfile are opened as scratch areas.

Files from :MK8abPARAM are combined to form the parameter file used to control the compilation. The files, summarised in Table 2, are created as a single workfile and an exofile is opened as a program file (\*DAØ). The macro selects the latest magnetic tape G4MK8abDUMP, the current operational version

(\*MTØ) and recompiles a new version to tape G4MK8ab%ADUMP. Unlike the operational system, only one generation of a test compilation is produced and the contents of files NEWSOURCE and NEWMENDS are preserved. The GIN parameter file now becomes:

Table 2

George 4 compilations - non-standard parameter file

Pseudo-directory	File*	Contents
MK8abPARAM	START	General GIN directives.
MK8abPARAM	NEW%AMENDS	Non-standard mends.
MK8abPARAM	NEW%ASOURCE	Non-standard chapters to be recompiled.
MK8abPARAM	%AMENDS	Additional restore time macros.
MK8abPARAM	%ADUMP	Dump commands.
MK8abPARAM	END	Termination directives.

\* %A is a substitution of the first parameter in the macro COMP-G4MK8ab.

The contents of any of these files may be changed according to circumstances to provide a new parameter file, however the most varied file will be NEW%ASOURCE which contains an entrant for each chapter which has been edited during the development of the enhancement. Its form is

```

MENDIN  }
MENDINC } chapter name, version number, new fgn
MENDTEST}

```

The non-ICL macros MENDIN, MENDINC and MENDTEST are used to compile a version of a new chapter from pseudo-directories :MK8ab and :MK8abMENDS and :MK8abTEST respectively and either or all macros may be called for during a compilation. The specification of these GIN macros is at Appendix A.

## 8 SETTING UP SUBSEQUENT ISSUES OF MARK 8

As already stated, ICL release periodically new issues of the George operating system. This section outlines the requirements which have been built into a macro called G4NEWMARK for incorporating a new issue of the operating system into the Mark 8 correction system.

The first task is to check the user notice for the new issue ICLKG4SYSTEM and see whether the compilation macros and programs need updating. A new

pseudo-user structure then has to be created within :GEORGE, similar to the structure described in section 5. The version definition file then has to be copied from the magnetic tape containing the George source (ICLKG4CHAPS) so that the relevant chapters may be copied into :MK8xy, where 8xy denotes the new mark and issue number. Chapters which contain RAE enhancement code are copied from :MK8abMENDS to :MK8xyMENDS if the local names and file generation numbers of the chapters correspond in the old and new issues. Similarly any non-ICL chapters, that is chapters with a local name which begins with 'RAE', are also copied. A similar copying exercise is also necessary to produce chapters for :MK8xyTEST. At this stage, the coding in chapters subject to an RAE mend must be checked manually to ensure that the incorporation of the 'Mends' and links to other chapters are still valid.

New files in :MK8xyPARAM have to be created by copying from :MK8abPARAM all those files which do not start with 'STD', or 'TOTALSOURCE'. The file STDMACROS has to be edited into :MK8xyPARAM so that all references to the old issue are changed to the new issue.

All the macros in :GEORGE need to be edited so that references to the old version are replaced by the new version number. Such macros are identified by their local name which includes the mark and issue number and hence the names of the new macros are also altered to reflect the change. The file structure for the new version of George is now complete and the initial compilation to include local mends (i.e. chapters in :MK8xyMENDS) can now be run.

The macro G4NEWMARK, which has been developed to simplify the conversion to a new issue of George, has six parameters, all mandatory, which are:

- %A - current mark
- %B - new mark number
- %C - tape serial number of reel 0 of chapter file
- %D - tape serial number of reel 1 of chapter file
- %E - tape serial number of the George 3 system tape
- %F - tape serial number of the George 4 system tape

This macro, which has a number of programs embedded within it, sets up all the new directories and generates the initial compilation, which is dumped to a magnetic tape (G4MK8xyDUMP). The macro will also generate a set of George 3 directories and a compilation at the same time. The George 3 version is produced as a contingency in the event of the paged George 4 system

developing unreliable characteristics. This macro has been used to convert the Mark 8.12 system to Mark 8.32 system, which will be introduced operationally when adequate testing has been completed.

## 9 CONCLUSIONS

The new method for making corrections to Mark 8 of ICL's George 3 and 4 operating system and the author's implementation of the scheme have been described. The author's version incorporates additional facilities to enable 'local' alterations to be made in parallel with changes published in software notices.

A set of pseudo-users has been created under the user :GEORGE which conveniently groups, edits, mends, chapters and compilation directives. To facilitate the new edit system, two macros G4UPDATE and COMP-G48ab have been developed. In order to compile non-standard versions of George 4, a macro COMP-G4MK8ab is used.

The correction system has been tested with Mark 8.12 and has proved to work satisfactorily.

For subsequent issues in the Mark 8 series, a further set of directories has to be produced and new files created, to replace the old mark by the new mark. To facilitate this change, a macro known as G4NEWMARK has been developed and used to convert from Mark 8.12 to Mark 8.32.

## Acknowledgment

The author wishes to acknowledge the work of M.J.D. Thurston who provided the programming effort for this correction system.

Appendix A

SPECIFICATIONS OF NON-ICL GIN COMPILATION MACROS

The source listings of the macros are located in :MK8abPARAM.STDMACROS for reference purposes.

MENDIN

MENDINC

MENDTEST

Function To compile a new version of a George chapter.

MENDIN compiles a chapter from the directory :MK8ab.

MENDINC compiles a chapter from the directory :MK8abMENDS.

MENDTEST compiles a chapter from the directory :MK8abTEST.

Format VMENDIN }  
VMENDINC } Chapter name, version number, file generation number  
VMENDTEST }

The macro name must be preceded by a space. The chapter name is mandatory. The version number and file generation number are optional, the latter having a default to the highest fgn available. The version number must be present if an fgn is present, although it may be null.

Output The GIN listing levels are given by the universals ARAEMENDIN, ARAEMENDINC and ARAEMENDTEST which are set to 1, 3 and 3 respectively if not previously set. The universal ARAELEVEL is set to 1.

Examples MENDINC LISTINIT, 8, 28 will compile :MK8abMENDS.LISTINIT8(28)  
MENDTEST VERBCLAS,, 2 will compile :MK8abTEST.VERBCLAS(2)

Appendix BEXAMPLE OF A SOFTWARE CORRECTION

In this Appendix an example of the processes required to implement an ICL published edit is presented.

Suppose that an edit to the George chapter LISTDIR6 is necessary to provide additional facilities to the LISTDIR command. The edit which is issued through the mechanism of software notices is given at Fig.B1. It will in fact correct a bug and allow the use of contextual parameters with the LISTDIR command (see Ref.2).

The lines following ED LISTDIR6(3), LISTDIR6(8) are input into a file called LISTDIR6(3/T08) in :MK8abEDITS. The edit then has to be checked for compatibility with any changes to the chapter which may have been generated by local (RAE) enhancements. The edit then has to be checked for any incompatibilities caused by local enhancements involving changes to the chapter. Any such chapters will be in directories :MK8abMENDS or :MK8abTEST. A statement should be supplied at the end of the edit quoting the reference to the software notice. In this example it is

S.W. 730 - 4/227 CONTEXTUAL LISTDIR.

The macro

G4UPDATE LISTDIR,3,8

is then run under :GEORGE and LISTDIR6 chapters in :MK8ab, :MK8abMENDS and :MK8abTEST are updated. An entry

MENDIN LISTDIR,6,8

or MENDINC LISTDIR,6,8

is automatically made in file NEWSOURCE for use in the compilation. Remember that a number of different chapters can be edited before the compilation phase need be entered. To safeguard against possible errors in the production of the edit, the checksum supplied with the edit is compared with one generated on reading the new chapter from :MK8ab.

The report (see Fig.B2) contains details of the source line changes made in producing

:MK8abTEST.LISTDIR6(8)

and :MK8abMENDS.LISTDIR6(8)

This is followed by a compilation report of outstanding chapters for compilation and a list of chapters already amended.

Finally the report concludes with a complete list of all ICL edits in the form of a narrative summary. It includes a reference to the software notices and gives the chapter names and the old and new generation numbers.

Assuming that all the elements of the compilation parameter file have been set-up (see section 6), all that is required to produce a new compilation for operational use is to issue the macro COMP-G48ab, where 8ab is the issue number, under the :GEORGE directory. As a background job this would be

```
RUNJOB jobname, :GEORGE, COMP-G48ab .
```

## Software Notice 227, Item 730 (Edit only)

1	2	3	4	5	6
1234567890	1234567890	1234567890	1234567890	1234567890	1234567890

!LISTDIR6/3/8/, (B2850,G3/4,RMENDIT)

MENDIT :GEO,LISTDIR,6,8

ED LISTDIR6(3),LISTDIR6(8)

```

T/4BM6/,I;4BM6 ...      BZE  0  TB3
; ,P/4C6Q/
T/6TQB/,I;6TF2 ...      MHUNT  3,CPB,CALAS
6TM= ...      LDX  7  ALOGLEN(3)
6TTG ...      ADN  7  2
6W3Q ...      SETUPCOR 7,3,ADATA,CREADL
; ,P/6W=2/
T/6X9=/,I;6W↑D ...      LDN  7  1
; ,T/6Y8G/,I;6Y8G ...      BZE  0  TNOLPA
; ,P/6YN6/
T/6↑MB/,I;6↑CJ ...      ADN  7  1
; ,T/7272/,I;6↑P↑ ...TNOLPA
6↑SJ ...      SMO  7
6↑X7 ...      LDN  7  CPDATA
6↑↑Q ...      STO  7  ACOMMUNE3(2)
724* ...TNOLP
; ,T/73KW/,I;73B4 ...      LDX  6  3
; ,T/76HL/,I;76HL ...      ADX  3  ACOMMUNE3(2)
; ,P/79FB/
T/79↑2/,I;79↑2 ...      DCH  0  0(3)
; ,P/7=Y=/
T/7?CW/,I;7?84 ...      LDX  2  1
; ,T/7#WQ/,I;7#KB ...      SBX  3  6
7#RL ...      SMO  FX2
7#↑W ...      STO  3  ACOMMUNE3
7*86 ...      BRN  TNOLP
; ,P/7*BB/
T/↑↑↑↑/,I;↑↑↑↑ ...63571141000800000000
; ,PE,E

```

1900 SS/1900 GEORGE 3 and 4/227

EDIT REPORT

PAGE 1

UPDATE GEORGE SOURCE SEGMENT IM832TEST.LISTDIR

UPDA MARK 1.5

```

LINE CHANGED FROM :- 2J46 ...      BZE 3 (0)      [J IF NO MORE
TO :-                2J46 ...      BZE 3 (0)

LINE CHANGED FROM :- 3DBB          MOVE 1 3
TO :-                3DBB          MOVE 1 3      [SET REQUESTED NAME AS CURRENT DIRRECT

LINE CHANGED FROM :- 4BM6 ...      BZE 0 TB2
TO :-                4BM6 ...      BZE 0 TB3

LINE CHANGED FROM :- 5XTB ...      LDX 7 STMP(1)
TO :-                5XTB ...      LDX 7 STMP(1)      [(T)

LINE CHANGED FROM :- 63WB ...      LDX 6 SFILE(1)  ['FILE'
TO :-                63WB ...      LDX 6 SFILE(1)

LINE CHANGED FROM :- 68QG ...      LDX 6 SMAG(1)  ['MAGS'
TO :-                68QG ...      LDX 6 SMAG(1)

LINE CHANGED FROM :- 6HG# ...      BNZ 4 T14      [J IF MAGTAPE
TO :-                6HG# ...      BNZ 4 T14

LINE CHANGED FROM :- 6JFG ...      LDX 3 ELAN(2)  [LANGUAGE
TO :-                6JFG ...      LDX 3 ELAN(2)

LINE CHANGED FROM :- 6SDN ...      [RETURN TO ZLISTDIR
TO :-                6SDN ...

LINE CHANGED FROM :- 6SKW ...
TO :-                6SKW ...

LINE INSERTED :-     MHUNT          3.CPB,CALAS
LINE INSERTED :-     LDX 7 ALOGLEN(3)
LINE DELETED :-      SETNCORE CPDATA-A1+2.3,ADATA,CREADL
LINE INSERTED :-     ADN 7 2
LINE INSERTED :-     SETUPCOR 7.3,ADATA,CREADL
LINE INSERTED :-     LDN 7 1
LINE CHANGED FROM :- 6Y8G          BZE 0 T51      [J IF NOT *LP
TO :-                6Y8G          BZE 0 T51
LINE INSERTED :-     6+CJ ...      ADN 7 1
LINE INSERTED :-     6+PT ...TNOLPA
    
```

Fig.B2

UPDATE GEORGE SOURCE SEGMENT MK832TEST.LISTDIRG

#UPDA MARK 1.5

```

LINE INSERTED :-      6*8J ...      SMO      7
LINE INSERTED :-      6*X7 ...      LDN      7 CPDATA
LINE INSERTED :-      6*TTQ ...      STO      7 ACOMMUNE3(2)
LINE INSERTED :-      724* ...TNOLP
LINE INSERTED :-      73B4 ...      LDX      6 3
LINE CHANGED FROM :-  76HL ...      ADM      5 CPDATA=A1+3*4
TO :-                76HL ...      ADX      5 ACOMMUNE3(2)
LINE DELETED :-      773= ...      SRL      5 2
LINE DELETED :-      77GW ...      STO      4 A1(3)
LINE DELETED :-      782G ...      ALTLEN   3,5
LINE DELETED :-      78GG ...      MHUNT    2,CPB,CUNI
LINE DELETED :-      78*G ...      MHUNTW   3,ADATA,CREADL
LINE CHANGED FROM :-  79*2 ...      DCH      0 CPDATA+2(3)
TO :-                79*2 ...      DCH      0 0(3)
LINE DELETED :-      7=DL ...      ADM      3 CPDATA+2
LINE INSERTED :-      77B4 ...      LDX      2 1
LINE INSERTED :-      7#KB ...      SBX      3 6
LINE INSERTED :-      7#RL ...      SMO      FX2
LINE DELETED :-      7#WQ ...      BRN      TS11
LINE INSERTED :-      7#*W ...      STO      3 ACOMMUNE3
LINE INSERTED :-      7*86 ...      BRN      TNOLP
LINE INSERTED :-      822HP...#SKI IFS
LINE INSERTED :-      826DP...      ADM      2 FUSER1-FCBRING
LINE INSERTED :-      82**P...#SKI IFS<1$1
+++++*****
END OF EDIT REPORT.  +++++*****

```

Fig.B2 (Contd.)

TM MATH 7603/3

#UPDA MARK 1.5 UPDATE GEORGE SOURCE SEGMENT MK832MENDS.L1STDIR6(B) PAGE 3

```

LINE CHANGED FROM :- 2J46 ... BZE 5 (0)
TO :- 2J46 ... BZE 5 (0) IJIF NO MORE

LINE CHANGED FROM :- 3DBB MOVE 1 3
TO :- 3DBB MOVE 1 3 [SET REQUESTED NAME AS CURRENT DIRECT

LINE CHANGED FROM :- 4BM6 ... BZE 0 TB2
TO :- 4BM6 ... BZE 0 TB3

LINE CHANGED FROM :- 5XT# ... LDX 7 STEMP(1)
TO :- 5XT# ... LDX 7 STEMP(1) [(T)

LINE CHANGED FROM :- 63W# ... LDX 6 SFILE(1)
TO :- 63W# ... LDX 6 SFILE(1) ['FILE'

LINE CHANGED FROM :- 68QG ... LDX 6 SMAG(1)
TO :- 68QG ... LDX 6 SMAG(1) ['MAGS'

LINE CHANGED FROM :- 6HG# ... BNZ 4 T14
TO :- 6HG# ... BNZ 4 T14 [J IF MAGTAPE

LINE CHANGED FROM :- 6JFG ... LDX 5 ELAN(2)
TO :- 6JFG ... LDX 5 ELAN(2) [LANGUAGE

LINE CHANGED FROM :- 6SDN ... [RETURN TO Z2LISTDIR
TO :- 6SDN ... [

LINE CHANGED FROM :- 6SKV ... [
TO :- 6SKV ... [

LINE INSERTED :- 6TF2 ... MHUNT 3,CPB,CALAS
LINE INSERTED :- 6TM# ... LDX 7 ALOGLEN(3)
LINE DELETED :- 6TQB SETNCORE CPDATA-A1+2,3,ADATA,CREADL
LINE INSERTED :- 6TTG ... ADN 7 2
LINE INSERTED :- 6WJQ ... SETUPCOR 7,3,ADATA,CREADL
LINE INSERTED :- 6WTD ... LDN 7 1
LINE CHANGED FROM :- 6YBG ... BZE 0 T51
TO :- 6YBG ... BZE 0 TNOLPA [J IF NOT *LP

LINE INSERTED :- 6+CJ ... ADN 7 1
LINE INSERTED :- 6+PT ... TNOLPA

```

Fig.B2 (Contd.)

UPDATE GEORGE SOURCE SEGMENT ;MK832MENDS.LISTDIR6(8)

#UPDA MARK 1.5

```

LINE INSERTED :-      6TSJ ...      SMO      7
LINE INSERTED :-      6TX7 ...      LDN      7 CPDATA
LINE INSERTED :-      6TTQ ...      STO      7 ACOMMUNE3(2)
LINE INSERTED :-      724* ...TNOLP
LINE INSERTED :-      73B4 ...      LDX      6 3
LINE CHANGED FROM :-      76HL      ADN      5 CPDATA-A1*3*4
TO :-                  76HL ...      ADX      5 ACOMMUNE3(2)
LINE DELETED :-      773=      SRL      5 2
LINE DELETED :-      77GW      STO      4 A1(3)
LINE DELETED :-      782G      ALTIEN   3,5
LINE DELETED :-      78G6      MHUNT    2,CPB,CUNI
LINE DELETED :-      78TQ      MHUNTW   3,ADATA,CREADL
LINE CHANGED FROM :-      79T2      DCH      0 CPDATA+2(3)
TO :-                  79T2 ...      DCH      0 0(3)
LINE DELETED :-      7=DL      ADN      3 CPDATA+2
LINE INSERTED :-      7784 ...      LDX      2 1
LINE INSERTED :-      7#KB ...      SBX      3 6
LINE INSERTED :-      7#RL ...      SMO      FX2
LINE DELETED :-      7#WQ      BRN      T511
LINE INSERTED :-      7#TW ...      STO      3 ACOMMUNE3
LINE INSERTED :-      7*86 ...      BRN      TNOLP
LINE INSERTED :-      822MP...#SKI IFS
LINE INSERTED :-      826DP...      ADN      2 FUSER1-FCBRING
LINE INSERTED :-      82=P...#SKI IFS<1$1
*****
END OF EDIT REPORT. *****

```

Fig.B2 (Contd.)

```
INCLUDED IN NEXT COMP :- MENDING LISTDIR,6,8
+++++++
START OF RESTORE PACK. ++++++
INCLUDED :- MENDIN CLOSEND,70,13
INCLUDED :- MENDIN CLOSEDIR,70,13
INCLUDED :- MENDIN JSASCAN,83,13
INCLUDED :- MENDIN FMOBJDL,83,3
INCLUDED :- MENDIN COPYA,8,10
INCLUDED :- MENDIN ADDICT,63,11
INCLUDED :- MENDIN JOBLIST,83,33
INCLUDED :- MENDIN IPBLISTC,8,20
INCLUDED :- MENDIN INITJOB,83,21
INCLUDED :- MENDIN FMOBJ,83,9
INCLUDED :- MENDIN DEWELL,83,43
INCLUDED :- MFNDIN INCEND,83,18
INCLUDED :- MENDIN WSJOBS,83,12
INCLUDED :- MENDIN INSERT,6,3
INCLUDED :- MENDIN WSPARAM,83,5
INCLUDED :- MENDIN WMTSTAT,83,5
INCLUDED :- MENDIN LISTDIR,6,8
+++++++
END OF RESTORE PACK. ++++++
```



REFERENCES

- | <u>No.</u> | <u>Author</u>                     | <u>Title, etc.</u>  |
|------------|-----------------------------------|---|
| 1          | ICL Technical<br>Publication 4384 | George 3 and 4 operations management manual.  |
| 2          | ICL Software<br>Notice            | 1900 George 3 and 4/227 dated 25 July 1975.   |
| 3          | R.T. Robinson<br>T.R.H. Sizer     | The planning and organisation aspects of the George 3<br>computing service at RAE.<br>RAE Technical Report 76022 (1976) |

Math 7603

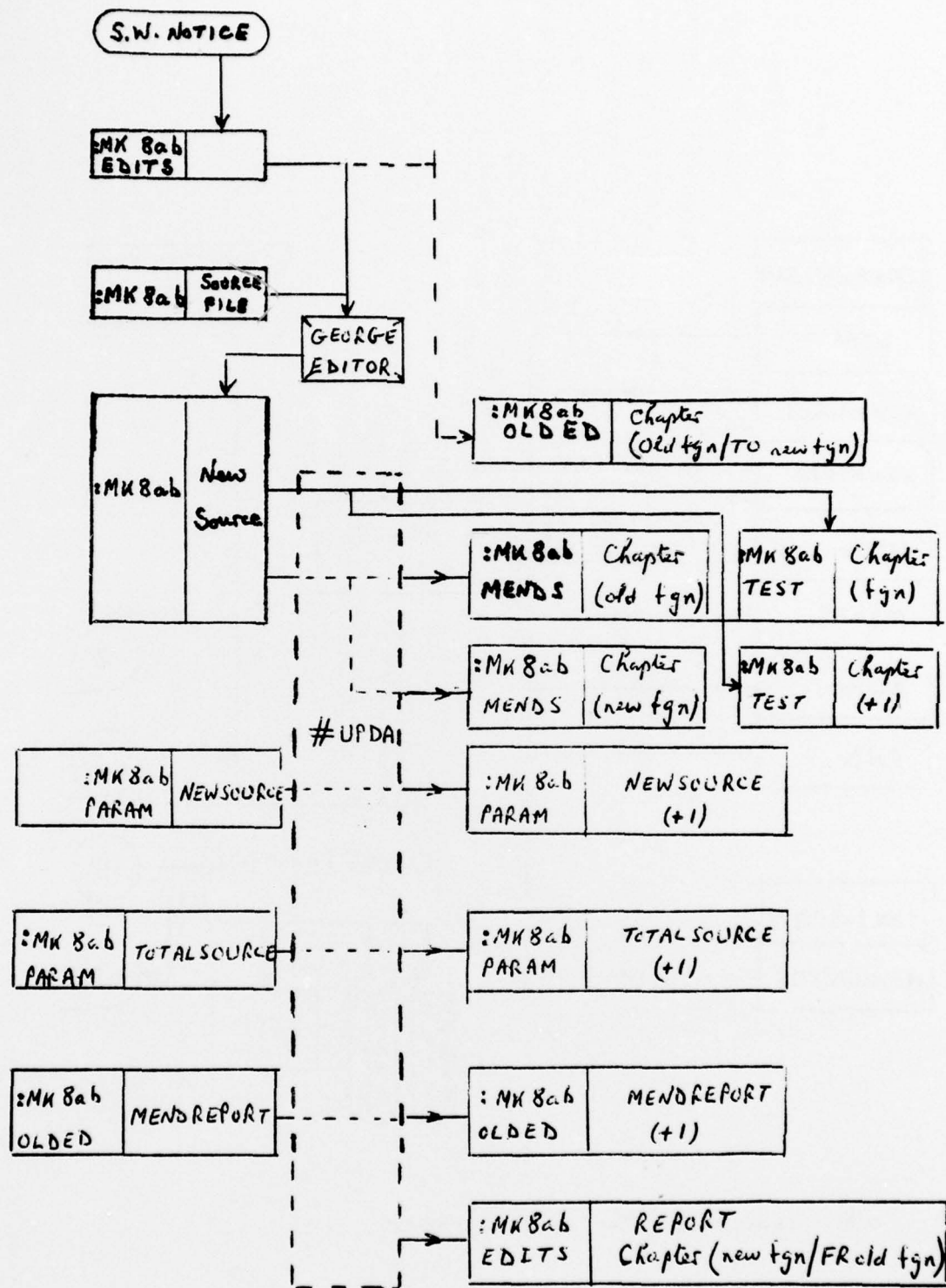
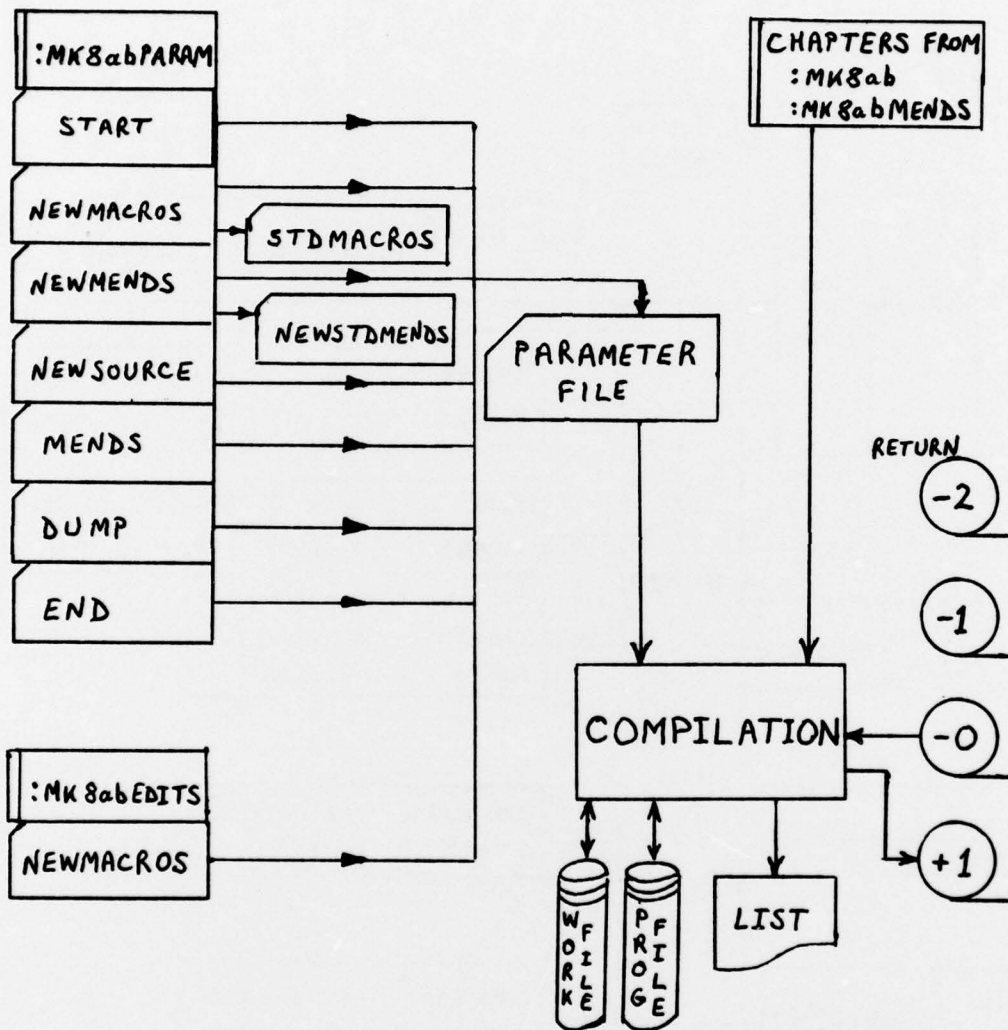

Fig.1 Functional diagram of G4UPDATE macro

Fig.2



ab indicates the issue number

Fig.2 Functional diagram of COMP-G48ab macro

Math 7603

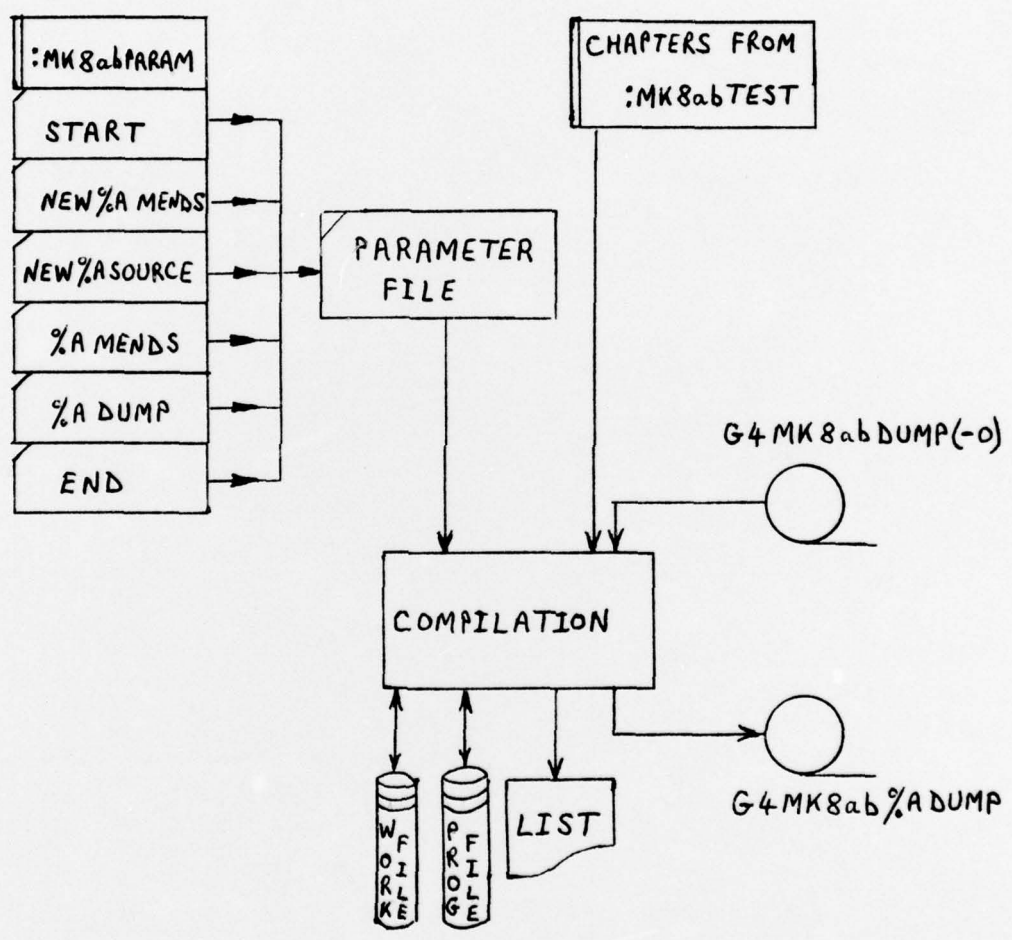

ab indicates the issue number.

%A is a representation of parameter substitution in the macro call.

Fig.3 Functional diagram of COMP-G4MK8ab macro (for development work)

## REPORT DOCUMENTATION PAGE

Overall security classification of this page

**UNCLASSIFIED**

As far as possible this page should contain only unclassified information. If it is necessary to enter classified information, the box above must be marked to indicate the classification, e.g. Restricted, Confidential or Secret.

1. DRIC Reference (to be added by DRIC)	2. Originator's Reference RAE TM Math 7603	3. Agency Reference N/A	4. Report Security Classification/Marking <b>UNCLASSIFIED</b>
5. DRIC Code for Originator 850100	6. Originator (Corporate Author) Name and Location Royal Aircraft Establishment, Farnborough, Hants, UK		
5a. Sponsoring Agency's Code N/A	6a. Sponsoring Agency (Contract Authority) Name and Location N/A		
7. Title <b>An adaptation of the ICL George 3 and 4 Mark 8 correction system to satisfy the RAE's requirements on its 1906S processor</b>			
7a. (For Translations) Title in Foreign Language			
7b. (For Conference Papers) Title, Place and Date of Conference			
8. Author 1. Surname, Initials Smithin, F.J.	9a. Author 2	9b. Authors 3, 4 ....	10. Date   Pages   Refs. May   28   3 1976
11. Contract Number N/A	12. Period N/A	13. Project	14. Other Reference Nos.
15. Distribution statement (a) Controlled by - <b>UNLIMITED</b> (b) Special limitations (if any) - <b>Head of Mathematics Department</b>			
16. Descriptors (Keywords) (Descriptors marked * are selected from TEST) <b>Digital computing. Operating systems.</b>			
17. Abstract <p style="margin-left: 20px;">✓ A new method of making changes to the George operating system was adopted by ICL when Mark 8 was released. The correction system offered by the manufacturers did not completely meet the RAE requirement and a modified system has been introduced. This Memorandum describes the correction system and RAE's implementation to enable 'in-house' development work to proceed in parallel with published changes to the system.</p> <p style="text-align: center; margin-left: 100px;">✕</p>			

F 5910/1