

AD-A033 522

UNIVERSITY ENGINEERS INC NORMAN OKLA

SMALL SCALE TESTS ON CONTROL METHODS FOR SOME LIQUEFIED NATURAL--ETC(U)

F/G 11/7

MAY 76 L E BROWN, W E MARTINSEN

DOT-CG-42355-A

UNCLASSIFIED

UE-308-FR

USCG-D-95-76

NL

1 OF 1  
AD  
A033522



END  
DATE  
FILMED  
2-77

13

FL

SMALL SCALE TESTS ON CONTROL METHODS  
FOR SOME LIQUEFIED NATURAL GAS HAZARDS

ADA033522



FINAL REPORT  
MAY 1976

Document is available to the U.S. Public through the  
National Technical Information Service,  
Springfield, Virginia 22161

DDC  
RECEIVED  
DEC 14 1976  
A

PREPARED FOR  
**U.S. DEPARTMENT OF TRANSPORTATION**  
**UNITED STATES COAST GUARD**  
**OFFICE OF RESEARCH AND DEVELOPMENT**  
**WASHINGTON, D.C. 20390**

Com... (handwritten)

**NOTICE**

This document is disseminated under the sponsorship of the U. S. Department of Transportation in the interest of information exchange. The United States Government assumes no liability for the contents or use thereof.

The work reported on herein was performed for the Marine Safety Technology Division of the U. S. Coast Guard Office of Research and Development. The views are those of the authors who are responsible for the facts and accuracy of the data. This report does not constitute a specification, standard or regulation.

ACQUISITION NO.	
NTIS	With Order <input checked="" type="checkbox"/>
DOC	Self Service <input type="checkbox"/>
UNCLASSIFIED	<input type="checkbox"/>
CLASSIFICATION	
BY	
DISTRIBUTION/AVAILABILITY CODE	
Dist.	AVAIL. AND/OR SPECIAL
A	

*Controlled*  
*3-1-84*

1. Report No. <b>19</b> <b>XSCG D-95-76</b>	2. Government Accession No. <b>15 DOT-CG-42355-A</b>	3. Recipient's Catalog No.	
4. Title and Subtitle <b>6 Small Scale Tests on Control Methods for Some Liquefied Natural Gas Hazards.</b>		5. Report Date <b>17 May 1976</b>	
7. Author(s) <b>10 L. E. Brown, W. E. Martinsen, S. P. Muhlenkamp, G. L. Puckett</b>		6. Performing Organization Code <b>14</b> Performing Organization Report No. <b>UE-308-FR</b>	
9. Performing Organization Name and Address <b>University Engineers, Inc. 1215 Westheimer Drive Norman, OK 73069</b>		10. Work Unit No. (TRAIS) <b>G-DST 3806.1</b>	
12. Sponsoring Agency Name and Address <b>Office of Research and Development U. S. Coast Guard Washington, DC 20590</b>		11. Contract or Grant No. <b>DOT-CG-42,355A, Task#1</b>	
15. Supplementary Notes <b>This report is supplementary to a previous report identified as performing organization report # UE-293-FR, Fire Safety Aboard LNG Vessels (CG-D-94-76). The U. S. Coast Guard's Research and Development technical representative for this work was Larry J. Olson.</b>		13. Type of Report and Period Covered <b>9 Final Report</b>	
16. Abstract <b>1289p.</b> A report of results of small scale (100 ft <sup>2</sup> <b>SQUARE FT</b> ) tests of some liquefied natural gas (LNG) hazard control methods and concepts. Tests were run to estimate dry chemical flow rate requirements for the extinguishment of fires from LNG pools with obstructions in the pool area and fires from LNG pools on water in a containment. Objectives were to obtain data for design of large-scale tests. Other small-scale tests examined the feasibility of other concepts for controlling hazards from spills of liquefied natural gas. Agent application rates required for extinguishment of obstructed LNG fires and LNG fires on water are not different from those effective on unobstructed fires on dry surfaces (if the functionality between burning rate and application rate is accounted for). Care must be exercised to assure uniform powder distribution on obstructed fires. Tests of water spray screens to reduce downwind vapor concentrations showed that the concept is practical and effective for small LNG spills, and that the mechanism of reduction is the addition of turbulence in the vapor zone. Tests of water spray screens to reduce radiant heating of exposures demonstrated no practical value for the concept except as an uneconomical alternative where spray directly on the exposure is not possible.			
17. Key Words <b>Liquefied Natural Gas (LNG) Fire Extinguishment Tests, Dry Chemical Extinguishing Agent Tests, Water Sprays, Flammable Vapor Control Method, Radiant Heating Control Method, LNG Fire Tests</b>		18. Distribution Statement <b>Document is available to the public through the National Technical Information Service, Springfield, Virginia 22161</b>	
19. Security Classif. (of this report) <b>Unclassified</b>	20. Security Classif. (of this page) <b>Unclassified</b>	21. No. of Pages <b>77</b>	22. Price

409 606 - IA - JP

# METRIC CONVERSION FACTORS

## Approximate Conversions to Metric Measures

Symbol	When You Know	Multiply by	To Find	Symbol
<b>LENGTH</b>				
in	inches	2.5	centimeters	cm
ft	feet	30	centimeters	cm
yd	yards	0.9	meters	m
mi	miles	1.6	kilometers	km
<b>AREA</b>				
sq in	square inches	6.5	square centimeters	cm <sup>2</sup>
sq ft	square feet	0.09	square meters	m <sup>2</sup>
sq yd	square yards	0.8	square meters	m <sup>2</sup>
sq mi	square miles	2.6	square kilometers	km <sup>2</sup>
acres	acres	0.4	hectares	ha
<b>MASS (weight)</b>				
oz	ounces	28	grams	g
lb	pounds	0.45	kilograms	kg
	short tons (2000 lb)	0.9	tonnes	t
<b>VOLUME</b>				
teaspoon	teaspoons	5	milliliters	ml
fluid ounce	fluid ounces	30	milliliters	ml
cup	cup	0.24	liters	l
quart	quarts	0.95	liters	l
gallon	gallons	3.8	liters	l
cu ft	cubic feet	0.03	cubic meters	m <sup>3</sup>
cu yd	cubic yards	0.76	cubic meters	m <sup>3</sup>

### TEMPERATURE (exact)

°F	Fahrenheit temperature	5/9 (after subtracting 32)	Celsius temperature	°C
----	------------------------	----------------------------	---------------------	----

## Approximate Conversions from Metric Measures

Symbol	When You Know	Multiply by	To Find	Symbol
<b>LENGTH</b>				
mm	millimeters	0.04	inches	in
cm	centimeters	0.4	inches	in
m	meters	3.3	feet	ft
km	kilometers	0.6	miles	mi
<b>AREA</b>				
cm <sup>2</sup>	square centimeters	0.16	square inches	in <sup>2</sup>
m <sup>2</sup>	square meters	1.2	square yards	yd <sup>2</sup>
km <sup>2</sup>	square kilometers	0.4	square miles	mi <sup>2</sup>
ha	hectares (10,000 m <sup>2</sup> )	2.5	acres	acres
<b>MASS (weight)</b>				
g	grams	0.035	ounces	oz
kg	kilograms	2.2	pounds	lb
t	tonnes (1000 kg)	1.1	short tons	short tons
<b>VOLUME</b>				
ml	milliliters	0.03	fluid ounces	fl oz
l	liters	2.1	pints	pt
l	liters	1.06	quarts	qt
m <sup>3</sup>	cubic meters	0.26	gallons	gal
m <sup>3</sup>	cubic meters	35	cubic feet	ft <sup>3</sup>
m <sup>3</sup>	cubic meters	1.3	cubic yards	yd <sup>3</sup>

### TEMPERATURE (exact)

°C	Celsius temperature	9/5 (then add 32)	Fahrenheit temperature	°F
----	---------------------	-------------------	------------------------	----

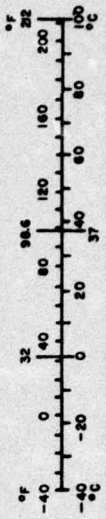
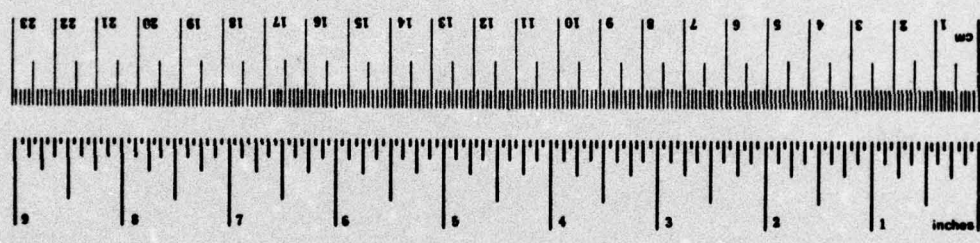

\*1 in = 2.54 (exactly). For other exact conversions and more detailed tables, see NBS Misc. Publ. 286, Units of Weight and Measures, Price \$2.25, SD Catalog No. C13.10286.

TABLE OF CONTENTS

	Page
SUMMARY OF RESULTS . . . . .	1
INTRODUCTION AND BACKGROUND . . . . .	3
GENERAL DESCRIPTION OF TEST FACILITIES . . . . .	5
EXTINGUISHMENT OF OBSTRUCTED LNG FIRES AND LNG FIRES ON WATER . . . . .	7
Facilities and Equipment . . . . .	7
Extinguishment of LNG Fires with Obstructions in the Fire Area . . . . .	9
Analysis of Data from Obstructed Fire Tests . . . . .	13
Extinguishment of Fires from LNG on Water . . . . .	27
REDUCTION OF LNG VAPOR CONCENTRATIONS USING WATER SPRAYS . . . . .	31
MITIGATION OF RADIATION FROM LNG FIRES USING WATER SPRAY . . . . .	55
CONCLUSIONS . . . . .	63
APPENDIX . . . . .	64

3

LIST OF FIGURES

Figure	Page
1. Location of Obstructions for the 10 ft by 10 ft Pool Fire Tests . . . . .	8
2. Extinguishment Times for Obstructed 100 ft <sup>2</sup> LNG Pool Fires as a Function of Applica- on tion Rate of Sodium Bicarbonate (SB), Potassium Bicarbonate (PB), and Urea- Potassium Bicarbonate (U-PB) . . . . .	12
3. Calculated Extinguishment Time as a Function of Sodium Bicarbonate Dry Chemical Appli- cation Rate (Time Averaged) and LNG Burning Rate. Individual Points are Data on Extinguishing Obstructed Fires in this Test Series . . . . .	19
4. Comparison of Calculated and Observed Extinguishment Times for Sodium Bicarbonate Agent on LNG Fires . . . . .	21
5. Calculated Extinguishment Time as a Function of Potassium Bicarbonate Dry Chemical Application Rate (Time Averaged) and LNG Burning Rate. Individual Points are Data on Extinguishing Obstructed Fires in this Test Series . . . . .	22
6. Comparison of Calculated and Observed Extinguishment Times for Potassium Bicarbonate Agent on LNG Fires . . . . .	23
7. Calculated Extinguishment Time as a Function of Urea-Potassium Bicarbonate Dry Chemical Application Rate (Time Averaged) and LNG Burning Rate. Individual Points are Data on Extinguishing Obstructed Fires in this Test Series. . . . .	24
8. Comparison of Calculated and Observed Extinguishment Times for Urea-Potassium Bicarbonate Agent on LNG Fires . . . . .	25

(4)

LIST OF FIGURES--Continued.

Figure	Page
9. Calculated Extinguishment Times as a Function of Agent Application Rate for LNG Fires Burning at 1.0 in/min Liquid Level Regression Rate . . . . .	26
10. Gas Sensor Layout for Vapor Dispersion Tests 1-4 (Vertical Dimensions not to Scale) . . . . .	32
11. Gas Sensor Layout for Vapor Dispersion Tests 5-12 (Vertical Distances not to Scale) . . . . .	33
12. Average Concentration as a Function of Distance. Tests 1-4 . . . . .	40
13. Average Concentration as a Function of Distance. Tests 1-4 . . . . .	41
14. Average Concentration as a Function of Distance. Tests 5-8 . . . . .	42
15. Average Concentration as a Function of Distance. Tests 5-8 . . . . .	43
16. Average Concentration as a Function of Distance. Tests 9-12 . . . . .	44
17. Average Concentration as a Function of Distance. Tests 9-12 . . . . .	45
18. Illustration of Mixing Effect of Water Spray . . . . .	47
19. Peak Concentrations as a Function of Distance. Tests 1-4 . . . . .	49
20. Peak Concentrations as a Function of Distance. Tests 1-4 . . . . .	50
21. Peak Concentrations as a Function of Distance. Tests 5-8 . . . . .	51
22. Peak Concentrations as a Function of Distance. Tests 5-8 . . . . .	52

5

LIST OF FIGURES--Continued.

Figure	Page
23. Peak Concentrations as a Function of Distance. Tests 9-12 . . . . .	53
24. Peak Concentrations as a Function of Distance. Tests 9-12 . . . . .	54
25. Water Spray Test Apparatus . . . . .	57
26. Percent Reduction in Radiant Heat Flux as a Function of Water Spray Flow Rate . . . . .	58
27. Percent Reduction in Radiant Heat Flux as a Function of Water Spray Flow Rate for One Nozzle and Constant Initial Heat Flux . . . . .	60
28. Percent Reduction in Radiant Heat Flux as a Function of Initial Heat Flux with the Water Spray Screen Held Constant . . . . .	61

(6)

LIST OF TABLES

Tables	Page
1. Summary of Obstructed LNG Pool Fire Extinguishment Tests . . . . .	11
2. Effect of Obstructions on Minimum Application Rates for LNG Fire Extinguishment . . . . .	14
3. Summary of Extinguishment Trials for LNG Fires on Water . . . . .	28
4. Spray Nozzles and Water Flow Rates Used During Dispersion Tests . . . . .	35
5. Gas Concentrations Measured During Dispersion Tests . . . . .	37
A-1. Results of Tests of Dry Chemical Handline and Portable Extinguishment of LNG Pool Fires . . . . .	65
A-2. Statistical Parameters from Regression Analysis . . . . .	72

SMALL SCALE TESTS ON CONTROL METHODS FOR SOME  
LIQUEFIED NATURAL GAS HAZARDS

SUMMARY OF RESULTS

This is a report of results of small scale (100 ft<sup>2</sup>) tests of some liquefied natural gas (LNG) hazard control methods and concepts. The work was conducted for the U.S. Coast Guard under Contract DOT-CG-42,355A. Tests were run to estimate dry chemical fire extinguishment flow rate requirements for the extinguishment of fires from LNG pools with obstructions in the pool area and fires from LNG pools on water in a containment. The objectives of these tests were to obtain data for the design of large-scale tests which are anticipated to be near the extremes of extinguishing system performance. Other small-scale tests were run to examine the feasibility of using small-scale tests to screen new concepts for controlling hazards from spills of liquefied natural gas (e.g. water sprays for vapor dispersion).

Obstructed fire extinguishment tests were conducted on 100 ft<sup>2</sup> pool fires obstructed by two 12 in dia cylinders each supporting an end of a length of 8 in dia metal culvert at a level about three feet above the LNG surface. Extinguishment devices were 20 and 30 lb capacity portable dry chemical extinguishers and a 150 lb capacity handline system. Agents tested included sodium bicarbonate, potassium bicarbonate, and urea-potassium bicarbonate. LNG burning rate (liquid level regression rate) was maintained at about 0.4 in min. Agent application rates for one attack point ranged from 0.014 to 0.062 lb/sec-ft<sup>2</sup>. Rates for two attack points ranged from 0.026 to 0.035.

Results of the obstructed fire extinguishment tests were not measurably different from results for unobstructed fire extinguishment tests. The obstructed tests demonstrated only that some minimum rate must be delivered to the fire to achieve a desired extinguishment time. Simply increasing flow rate will not

assure that the minimum application rate is achieved. Two attack points offer more flexibility in achieving proper application of dry chemical agents to obstructed fires.

Tests of extinguishment of unobstructed fires from LNG on water in a 100 ft<sup>2</sup> pool were run to assure that agent effectiveness was essentially unchanged from that observed for fires from LNG on dry surfaces. No differences in effectiveness were demonstrated (if the functionality between burning rate and application rate is accounted for). Ice formation beneath the LNG tended to reduce burning rate in these tests in a containment, so that extinguishment could be achieved at fairly low agent application rates.

Tests were run for evaluation of the concept of using water sprays downwind of LNG spills to reduce more distant downwind flammable vapor concentrations. The concept appears to be effective for small spills. The mechanism of reduction of vapor concentrations from LNG is apparently an increase in turbulent mixing, with little or no heat transfer or chemical effects. Water sprays would probably be slightly more effective on water-soluble vapors.

Tests were also run to evaluate the concept of using water sprays between fires and "targets" to reduce radiant heating reaching exposed areas. Water sprays can reduce the radiant heating reaching exposures, but the effect is not large unless the spray is very heavy (dense). Direct application of water to an exposed surface is a much more effective and economical technique of reducing heating of exposed areas.

The general conclusion from the fire extinguishment tests is that no unusual difficulties should be encountered in large-scale tests, if care is taken to ensure that extinguishing agents can be properly applied to all fire areas. With proper agent application, the required application rate should not differ from the rate required for unobstructed fires. Conversely, using an increased application rate without regard for how the agent is applied will not be sufficient to assure adequate coverage of fire areas shadowed by equipment.

## INTRODUCTION AND BACKGROUND

The test program described here is part of a study to assess the hazard control system capabilities needed for control of liquefied natural gas (LNG) fire hazards aboard marine LNG tankers and at adjacent docks. Dock fires and fire control system capabilities are a part of the study only in relation to fire hazards to the ship. This work was conducted under Contract DOT-CG-42,355A for the U.S. Coast Guard.

The objectives of the test series were to investigate the feasibility of selected LNG hazard control concepts in small-scale tests, to obtain quantitative data on extinguishment of obstructed LNG fires for use both as basic data and as data for the design of large-scale LNG fire extinguishment tests, and to identify potential operational and instrumentation deficiencies that might be encountered in subsequent large-scale testing of the hazard control concepts. This pilot series of tests was considered necessary because test conditions in the large-scale tests are planned to be near the extremes of control system performance on the hazard configuration being tested. The use of small-scale pilot tests was expected to reduce the number of expensive, large-scale tests required.

The analytic portion of this study<sup>1</sup> showed that for a shipboard LNG fire hazard control system to be effective, the following system design criteria must be fulfilled:

1. Because of the high probability of post-extinguishment reignition of the methane-air mixture by heated metal or insulation systems, burning time should be limited to reduce such heating. The fire control system must be activated and in full operation in less than 45 seconds.
2. Extinguishing agent dispensing systems (normally dry chemical) must be located to control fires anywhere along the deck.

---

<sup>1</sup>J. R. Welker, et al., "Fire Safety Aboard LNG Vessels," Final Report on U.S. Coast Guard Contract DOT-CG-42,355A, Task 1, January 1976.

3. Fire extinguishing systems must be effective for fires in obstructed areas. Virtually every spill aboard an LNG tanker will be in a highly congested area.
4. Supplies of agents and carrier fluids or gases must be adequate to assure control of the hazards designed for. Equipment must be capable of properly dispensing the agents at adequate application rates to control the types and sizes of hazards that might occur.

Dry chemical fire-fighting agents are the only proven LNG fire extinguishment compounds for open-air LNG fires. As reviewed in the analytical portion of this study mentioned earlier, most of the past LNG fire extinguishment tests have been conducted on unobstructed LNG spill fires. The few tests conducted on obstructed fires provided only qualitative results that suggested that obstructed fires are more difficult to extinguish because heated obstructions may reignite the fire and because obstructions interfere with proper agent application (fire shadowing). Although the principal purpose of this extinguishment test series was to attempt to establish minimum equipment size and application rate ranges for use in designing large-scale tests, a secondary purpose was to obtain a limited amount of quantitative data on extinguishment of small obstructed fires. One and two points of attack were studied because both techniques are provided by the tentative IMCO code and, usually, by current ship design.

The utility of water in controlling thermal fluxes from LNG fires, fighting LNG fires, and reducing the hazard from LNG vapor clouds has been discussed but not quantitatively demonstrated. The inexhaustible reservoir of water available to an LNG tanker and its instant availability through shipboard fire water systems make this agent very attractive for LNG spill hazard control aboard tankers. Each of the above noted hazard control concepts utilizing water was also experimentally evaluated in this series of tests.

## GENERAL DESCRIPTION OF TEST FACILITIES

Field tests were conducted at University Engineers' test facility in Norman, Oklahoma. Ten acres of a 40-acre site have been developed for fire fighting and vapor dispersion research and testing. The LNG spill pans used in this study were so located on the test field that under any environmental conditions the flammable vapor cloud could be confined well within the site property lines. During the test period, security was maintained around the clock.

LNG used in the test program was purchased from Cincinnati Gas and Electric Co, and delivered to the test site in a 10,000 gal over-the-road LNG tanker. Testing was initiated on November 19, 1975, and completed November 24, 1975. During the test period the LNG tanker was used as the fuel storage tank. LNG was transferred from the tanker to the test pan through a fully insulated LNG transfer line fabricated by University Engineers as part of a previous LNG fire test program<sup>2</sup>. LNG level in the test pans was continuously monitored during testing using a hydraulic head technique developed by University Engineers<sup>2</sup>.

In each test a combination of instruments was used to extract a maximum amount of useful data. Instrumentation for each test series is described in the discussion of each series. Instrument outputs were recorded on paper charts using Leeds and Northrup Speedomax X/L 680 records and a 20 channel Metrodata DL-620 magnetic tape data logger. Dual data logging was utilized to minimize the possible loss of data due to recorder malfunction if only one logging system was used. During testing, 35 mm still and 16 mm movie coverage was obtained.

Test personnel directly involved in hazard control testing and LNG handling were provided both cryogenic and fire protective

---

<sup>2</sup>University Engineers, Inc., "An Experimental Study on the Mitigation of Flammable Vapor Dispersion and Fire Hazards Immediately Following LNG Spills on Land," Report to American Gas Association, AGA Project IS-100-1 (February 1974).

clothing. Other test personnel and observers were located at a safe distance from the test pan.

The control of fire radiation using a water curtain was studied in the laboratory using the University of Oklahoma ignition cabinet<sup>3</sup>. This device was especially suited for this work because a broad range of controlled flame radiant fluxes can be obtained. Tests were conducted at incident energy levels ranging from 5,000 Btu/hr-ft<sup>2</sup> to 25,000 Btu/hr-ft<sup>2</sup>.

The detailed test procedure for each series is described in subsequent sections of this report.

---

<sup>3</sup>Koohyar, A. N., J. R. Welker, and C. M. Sliepcevich, "An Experimental Technique for the Ignition of Solids by Flame Irradiation," Fire Technology, 4, 221 (1968).

EXTINGUISHMENT OF OBSTRUCTED LNG FIRES AND  
LNG FIRES ON WATER

Present shipboard dry chemical fire fighting systems and those proposed by the tentative IMCO code in most cases provide two independent powder streams for all shipboard cargo handling areas. In some ships' cargo manifold drip pan areas a fixed monitor nozzle that can be actuated from the cargo compressor room is being provided to extinguish drip pan fires. Powder application rate and nozzle performance guidelines must be established to assure that dry chemical equipment required aboard LNG tankers can extinguish the potential fires. The small scale test program described herein was designed to provide some of this data.

FACILITIES AND EQUIPMENT

LNG fire extinguishment tests were conducted in a 10-ft by 10-ft pit approximately 2 ft deep. The pit had ordinary concrete walls and an insulating floor of foamed cellular concrete. Insulating concrete was used to minimize the ground heating effect and thereby conserve LNG by reducing the boil-off rate until the pool was ignited. The fire size was large enough to indicate powder flow rates required for large-scale tests. The burning rates were typical of those found for small steady state fires. Corrections to powder flow rates required to extinguish fires at higher burning rates can be provided by the data from earlier tests<sup>2</sup>.

For most of the extinguishment tests, obstructions were placed in the pit. Obstructions consisted of two 20 gal steel drums and two 10-ft lengths of 8-inch diameter metal culvert arranged as shown in Figure 1. These materials were chosen to simulate the obstructing effect of large piping, valves, pipe supports, etc., which are associated with the cargo handling system on an LNG ship's deck where an LNG fire might occur. For extinguishment tests of spills on water, the obstructions were

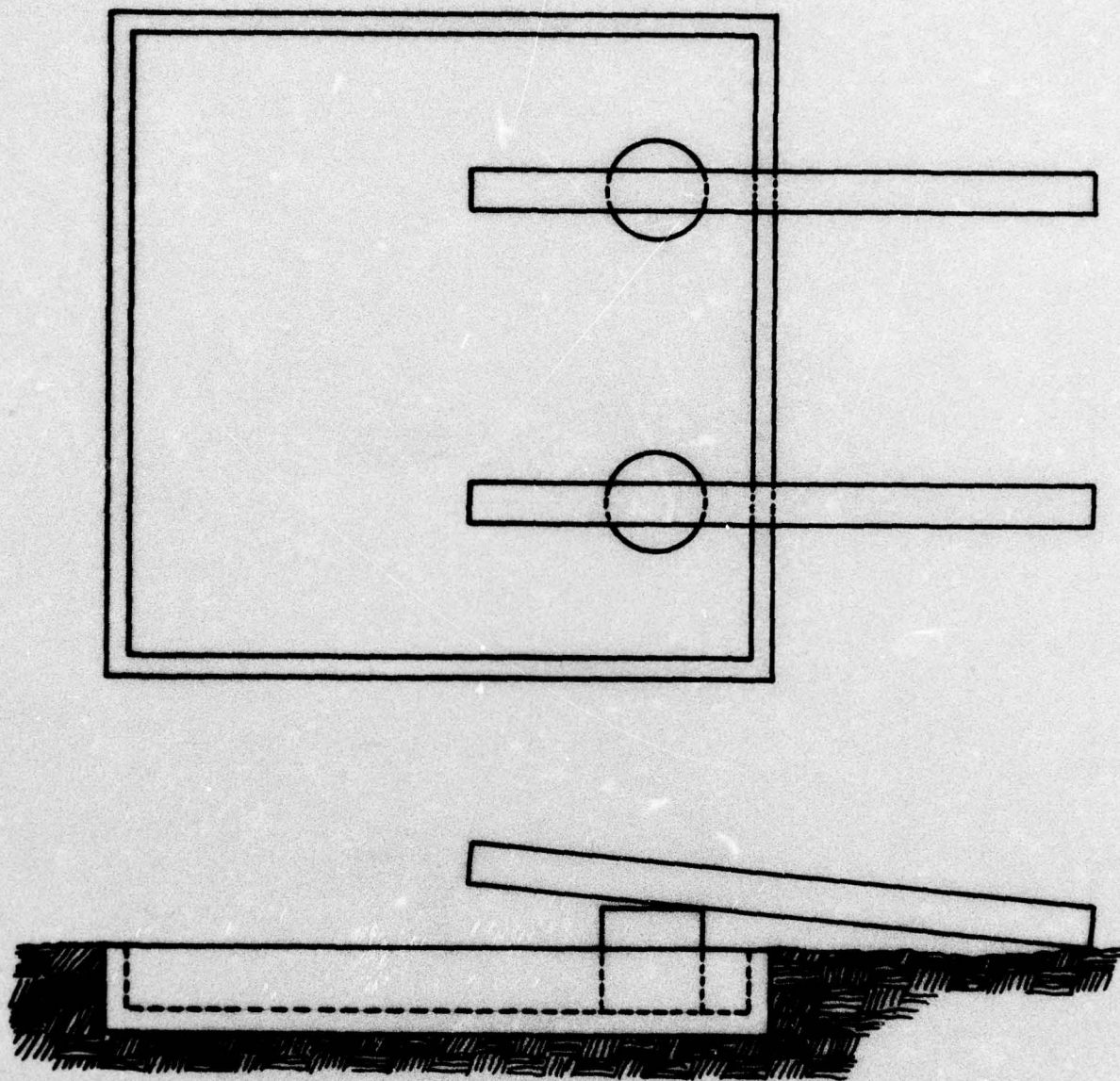

Figure 1. Location of obstructions for the 10 ft by 10 ft pool fire tests.

removed, the pit was filled with approximately 10 inches of water and then the LNG was spilled onto the water.

The LNG vapor dispersion tests were conducted in a 10-ft diameter stainless steel pan containing stainless steel heating tubes located near the bottom. Water was circulated through the tubes to heat the LNG and thereby increase the vaporization rate. A full description of this pan is given in Reference 2.

Water for tests was supplied from a portable 6,000 gal reservoir replenished by tank trucks. Three gasoline engine driven pumps were used to supply water from the reservoir to the various pieces of equipment used in the tests. A large pump rated for 150 gpm was used to supply water at 100 psi. The two smaller pumps were capable of supplying about half this, 75 gpm at 50 psi.

Three fire equipment manufacturers supplied the dry chemical fire extinguishers used for the LNG fire extinguishment tests. This equipment included three wheeled engines (nominal agent capacity of 150 lb each) and eight portables (six 30-lb agent capacity and two 20-lb capacity). These were recharged on-site during the tests. Sodium bicarbonate, urea-potassium bicarbonate, and potassium bicarbonate dry chemicals were evaluated in the program.

#### EXTINGUISHMENT OF LNG FIRES WITH OBSTRUCTIONS IN THE FIRE AREA

The obstructed LNG fire extinguishment tests were conducted in the 10-ft by 10-ft pit with obstructions. LNG was loaded into the 2-ft deep pit through the aluminum transfer line. When the LNG depth reached 8 to 10 inches, flow was stopped, the discharge section of transfer line was moved to a safe location, and the pool was ignited. Once ignited, the LNG was allowed to burn for 30 seconds before extinguishment was attempted. This procedure allowed the fire to develop and provided time in which the obstructions might be heated by the flame so that they could act as re-ignition sources.

---

<sup>2</sup>University Engineers, Inc. "An Experimental Study of the Mitigation of Flammable Vapor Dispersion and Fire Hazards Immediately Following LNG Spills on Land." Report to American Gas Association, AGA Phase II, AGA Project IS-100-1 (February 1974).

In general, the first extinguishment attempt in a given series of tests was made by a professional fire fighter highly trained to demonstrate and obtain ratings for dry chemical fire fighting equipment sold by his employer, an equipment manufacturer. This first attempt was made with a single hand-portable dry chemical extinguisher. The first attempt was followed by extinguishment attempts at increasingly higher dry chemical application rates ( $\text{lb}/\text{sec}\text{-ft}^2$ ) obtained by using two portable extinguishers and then a single handline from a wheeled engine. The second portable extinguisher was operated by a semi-skilled fire fighter (some past experience in extinguishing LNG fires) and the handline was used by the professional fire fighter. For each test after the first, the LNG was re-ignited and allowed to burn for approximately 30 seconds so that the pre-burn time for each test was constant. Extinguishment times were measured by two observers using stop watches; time was marked from actuation of the extinguisher to cessation of combustion noise from the fire. The reported extinguishment times are the average of the two independent measurements. Extinguishment times are tabulated in Table 1.

The first extinguishment attempt (Test 21) was made using one portable extinguisher charged with potassium bicarbonate powder. During this test small flames were observed burning on the soil just outside and upwind of the pit. This caused some initial fire extinguishment problems until the source of fuel for these flames was determined. The pit walls and floor had not been poured at the same time, therefore there was a joint between the walls and the floor which was not liquid tight. Consequently some LNG leaked through the joint, vaporized in the soil, and vapor seeped upward to the surface of the soil where it was ignited. This problem was overcome by stationing the second fire fighter near the extraneous flames so that he could extinguish them while the professional fire fighter attacked the pool fire. In this way it was possible to eliminate the problem without prejudicing the test data.

Figure 2 shows the extinguishment times as a function of application rate for the three dry chemicals tested. The data suggest a slight advantage of two attack points over a single

TABLE 1  
SUMMARY OF OBSTRUCTED LNG POOL FIRE EXTINGUISHMENT TESTS

Test No.	Actual Order of Tests	LNG Pool Area (ft <sup>2</sup> )	LNG Burning Rate (in/min)	Dry Chemical Type	Dry Chemical Equipment	Dry Chemical Applic. Rate (lb/sec-ft <sup>2</sup> )	Extinguish-ment Time (sec)	Comments
17	11	100	0.4	UREA-KHCO <sub>3</sub>	1 port.	0.020	3.9	
17A	12	100	0.4	UREA-KHCO <sub>3</sub>	1 port.	0.015	5.7	
18	13	100	0.4	UREA-KHCO <sub>3</sub>	1 hand.	0.044	2.0	
18A	14	100	0.4	UREA-KHCO <sub>3</sub>	1 hand.	0.028	3.5	45 sec pre-burn. Re-ignited spontaneously
19	15	100	0.4	UREA-KHCO <sub>3</sub>	2 port.	0.026	2.8	
21	1	100	0.4	KHCO <sub>3</sub>	1 port.	0.014	NE	Ignited by external flames from seepage from the pool
22	2	100	0.4	KHCO <sub>3</sub>	2 port.	0.033	5.8	
23	3	100	0.4	KHCO <sub>3</sub>	1 hand.	0.031	10.7	
23A	4	100	0.4	KHCO <sub>3</sub>	1 hand.	0.042	9.3	
25	5	100	0.4	NaHCO <sub>3</sub>	1 port.	0.013	NE	
25A	6	100	0.4	NaHCO <sub>3</sub>	2 port.	0.035	5.8	
26	9	100	0.4	NaHCO <sub>3</sub>	1 hand.	0.050	4.2	
26A	10	100	0.4	NaHCO <sub>3</sub>	1 hand.	0.062	4.2	
27	7	100	0.4	NaHCO <sub>3</sub>	2 port.	0.034	5.3	
27A	8	100	0.4	NaHCO <sub>3</sub>	2 port.	0.028	8.2	

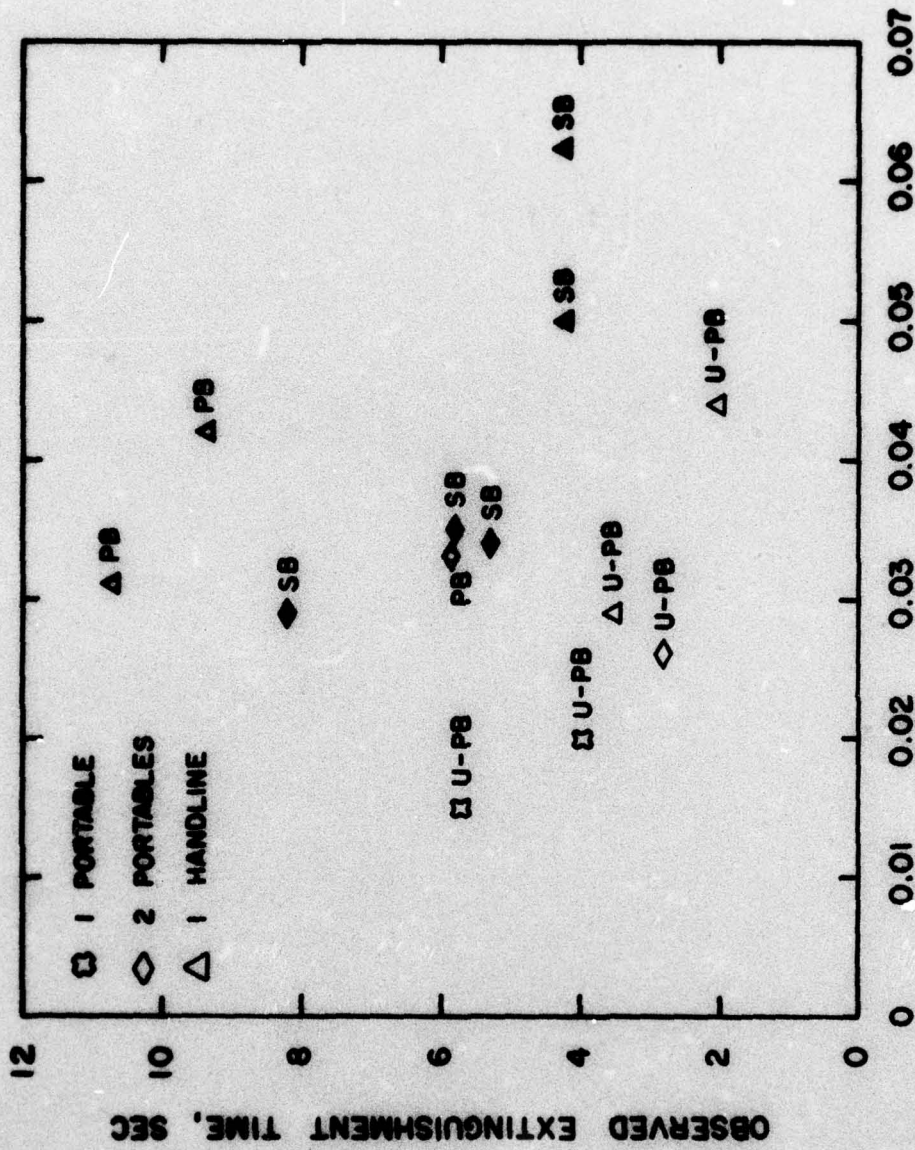

DRY CHEMICAL APPLICATION RATE, LB/SEC - FT<sup>2</sup>

Figure 2. Extinguishment times for obstructed 100 ft<sup>2</sup> LNG pool fires as a function of application rate of sodium bicarbonate (SB), potassium bicarbonate (PB), and urea-potassium bicarbonate (U-PB).

attack point at a given agent application rate. This advantage is best illustrated by the results of tests 22 and 23 applying potassium bicarbonate at about .03 lbs/sec-ft<sup>2</sup>. Extinguishing time for a single handline (Test 23) was about 11 seconds compared to about six seconds for two-point attack with two portable extinguishers (Test 22). Tests 18A and 19 indicate a similar effect.

Test 18A was the only test during which an observable reignition occurred. Approximately three seconds after the fire was extinguished, the plume was reignited from a source outside the pit (probably from the wire in the safety fence around the pit. This reignition is directly attributable to the longer pre-burn time. The three second delay in reigniting represents the time needed in this test for the flammable LNG vapor plume to re-establish itself and then contact the hot surface with a portion of the plume which is within the flammable limits.

#### Analysis of Data from Obstructed Fire Tests

The obstructed fire extinguishment test data are compared with unobstructed test data using two parameters. The first parameter is the effect of obstructions on the minimum dry chemical application rate needed to extinguish an LNG fire. The second parameter is the effect of obstructions on extinguishment time as the application rate of dry chemical agent is increased above the minimum.

"Minimum" dry chemical application rates for extinguishment of both obstructed and unobstructed LNG fires are shown in Table 2. The minimum rate data for unobstructed fires were selected from data obtained in earlier testing done for the American Gas Association<sup>2</sup>. The minimum rate shown is the lowest rate at which an agent successfully extinguished at least one unobstructed fire. It is also the lowest rate attempted. Generally, that success was not repeated or was not repeatable in the AGA test series, and failures occurred at rates up to six times the "minimum" rate. "Minimum" rates and unsuccessful rates shown for obstructed fires are results from the present test series.

Table 2 indicates that obstructed fires are not extinguished at application rates similar to those which produced minimum success

TABLE 2  
EFFECT OF OBSTRUCTIONS ON MINIMUM APPLICATION RATES FOR LNG FIRE EXTINGUISHMENT

	Sodium Bicarbonate	Potassium Bicarbonate	Urea- Potassium Bicarbonate
Minimum application rate to extinguish unobstructed fire, one attempt, one success. 0.5 in/min burn rate. (lbs/sec-ft <sup>2</sup> )	0.01	0.008	0.003
Test application rate at which obstructed fire not extinguished, one attempt. 0.4 in/min burn rate (lbs/sec-ft <sup>2</sup> )	0.013	0.014	--
Test application rate at which obstructed fire was extinguished (lowest rate tested above the non-extinguishment rate), one attempt, one success. 0.4 in/min burn rate (lbs/sec-ft <sup>2</sup> )	0.028	0.031	0.015

for unobstructed fires. At about three to four times the "minimum" application rates for unobstructed fires, extinguishment was achieved. Note that because of equipment and pool size limitations in this test program, the lowest available test application rate for urea-potassium bicarbonate was significantly higher (x 7.5) than a previously demonstrated "minimum" rate for unobstructed fires. Consequently, the "minimum" urea-potassium bicarbonate application rate for obstructed fires is probably much less than that shown in Table 2.

Because application rate in all test series to date is actually only a time-average rate rather than an instantaneous rate for each square foot of fire area, it has limitations as a quantitative value. The instantaneous rate of powder application at which extinguishment occurs for each square foot of fire is not known. More significantly for interpretation of Table 2, "minimum" application rates for extinguishment of unobstructed fires are actually only the lowest rates tested. Data from the present series of tests on obstructed fires are limited by numbers of tests, equipment limitations, and the semi-quantitative nature of the "application rate" concept. It is possible that additional tests using the minimum rate for unobstructed fires would have produced a successful extinguishment of an obstructed fire. Given the fact of a slightly higher burning rate for the unobstructed fire data (0.5 in/min versus 0.4 in/min for the obstructed fires) and consistent success on unobstructed fires at agent application rates equal to or higher than the minimum shown for obstructed fires, one interpretation might suggest an advantage of higher application rate if obstructions are in the fire zone. The alternative interpretation might suggest that obstructions do not affect fire behavior or extinguishing agent effectiveness for equally effective application patterns. Consequently, the conservative practice in designing large-scale tests to confirm predicted extinguishing system capabilities would not increase the application rate for obstructed areas by increasing agent flow rates, but would instead insure that in all circumstances, no less than some chosen minimum application rate could be delivered to all potential fire areas. Because the sensitivity of the test results is unknown and no advantage in using higher

application rates for obstructed fire areas was proven, the conservative practice to use in designing large-scale tests should be based upon no assumed advantage of higher application rates. Again with reference to some deficiencies in current state of the art of design information, the rate chosen may need to be higher than the commonly used rates, simply because present design practice uses the time-average rate rather than actual. This apparent paradox can be sidestepped by defining application rate as a delivery rate in the predicted agent delivery pattern. By this procedure, if the predicted target area of the delivery pattern at any instant is 5 square feet, the application rate for a nozzle delivering 45 lbs/sec would be 9 lbs/sq ft-sec in the affected area. This method of specification would narrow down the actual requirements for extinguishment and would eliminate some anomalies in the time-averaged method of specification. The portion of the true requirement that would remain unknown would be the actual application time for each square foot of area of large areas, since the application pattern would move across a larger area.

Another approach to defining the application rate required for fire extinguishment is provided by consideration of the mechanism of fire extinguishment. While some of the extinguishment mechanism may be due to physical factors, the chemical interception of the free radicals in the combustion chain is probably the major mechanism. The rate of application of dry chemical powder required for extinguishment then depends on the rate of production of free radicals, which is proportional to the total burning rate of LNG. Any powder beyond the minimum or critical application rate will lead to more rapid extinction. Mathematically, the relationship can be expressed approximately by

$$t = K \left( \frac{A - A_{cr}}{B} \right)^a \quad (1)$$

where the form of the equation has been chosen to correspond to the data. In Equation 1,

- t = extinguishment time, sec
- A = dry chemical application rate, lb/sec-ft<sup>2</sup>
- A<sub>cr</sub> = critical application rate, lb/sec-ft<sup>2</sup>

B = LNG burning rate, in/min

K, a = constants obtained by regression analysis

The equation indicates that the time to extinguish an LNG fire with dry chemicals is dependent on the ratio of rate at which the dry chemical is applied and the rate at which the LNG is burning. The application rate term,  $(A - A_{Cr})$  is the excess powder used to extinguish the fire above the minimum powder application rate necessary for fire extinguishment. The values of  $A_{Cr}$  used in the correlations were chosen to allow Equation 1 to be written in a linear form for the correlation of data. It is near but below the lowest rate tested that would extinguish LNG fires with commercially-available equipment. To attempt design of equipment for rates lower than  $A_{Cr}$  would probably be possible, but would not be economically practical.

The appendix lists all of the data used in these analyses. Note that the data are for portables and hand-lines only; no monitor nozzle or fixed system data are included. Data for fixed systems and monitor nozzles were deleted so that the analyses would be representative of extinguishment tests where the human factor (the fire fighter) is a significant element.

The initial comparison of data from the present series of tests with correlations of previous data on unobstructed fire extinguishment revealed no distinguishable difference between the two sets of data. Two interpretations, possibly mutually exclusive, can be made for this result. The result may mean that there are no differences in the two sets of data, and extinguishment time for a given agent flow rate and burning rate is not increased by obstructions in the pool fire area. The second interpretation is that the result is inconclusive in that the sensitivity of the analytical or test methodology is inadequate to demonstrate a difference caused by obstructions in the pool fire area. If the second interpretation is correct, the source of the insensitivity probably lies in some ratio of the degree of obstruction of the agent application path and the pool size. Larger pool sizes (fire areas), particularly incorporating a larger area extending further behind the obstructions, would expand the time increments and

improve the element of observation interval. However, because no systematic study of extinguishment of obstructed fires has been done prior to this series of tests, and because scale effect of obstructions is not known, determination of the proper interpretation is not presently possible. The shortcoming has little practical effect upon the design of large tests to determine the adequacy of the recommended levels of extinguishing capability, since this series of tests indicates that large increases in agent delivery rates are not necessary. What appears to be the ruling parameter for designing effective fire extinguishing systems for either obstructed or unobstructed fires is delivery of adequate agent to the fire. If all portions of the fire area do not receive the minimum application rate of agent required, either because of obstructions or because of fire fighter inexperience in properly applying the agent, the fire will not be extinguished regardless of the time-averaged application rate of the system.

Because there was no difference in the two sets of data for fire extinguishment time as a function of application rate, all applicable data from both unobstructed and obstructed tests were included in the multiple regression analysis. Data points for the unobstructed tests are shown with the calculated curves.

For sodium bicarbonate powder, 31 data points were used in analysis. Three other data points were for fires that were not extinguished and were therefore not included. The calculated best fit for the sodium bicarbonate data is given by Equation 2.

$$t = 2.3 \left( \frac{A - 0.01}{B} \right)^{-0.36} \quad (2)$$

The calculated extinguishment time as a function of LNG burning rate and excess application rate of sodium bicarbonate (application rate exceeding the minimum required for extinguishment) is shown graphically in Figure 3. The data from the USCG tests burning at 0.4 in/min are included in the figure so that it can be seen how the obstructed fire extinguishment data compare with the calculated curve. Figure 4 shows the relationship between the calculated and observed extinguishment times for the 31 tests used in the analysis.

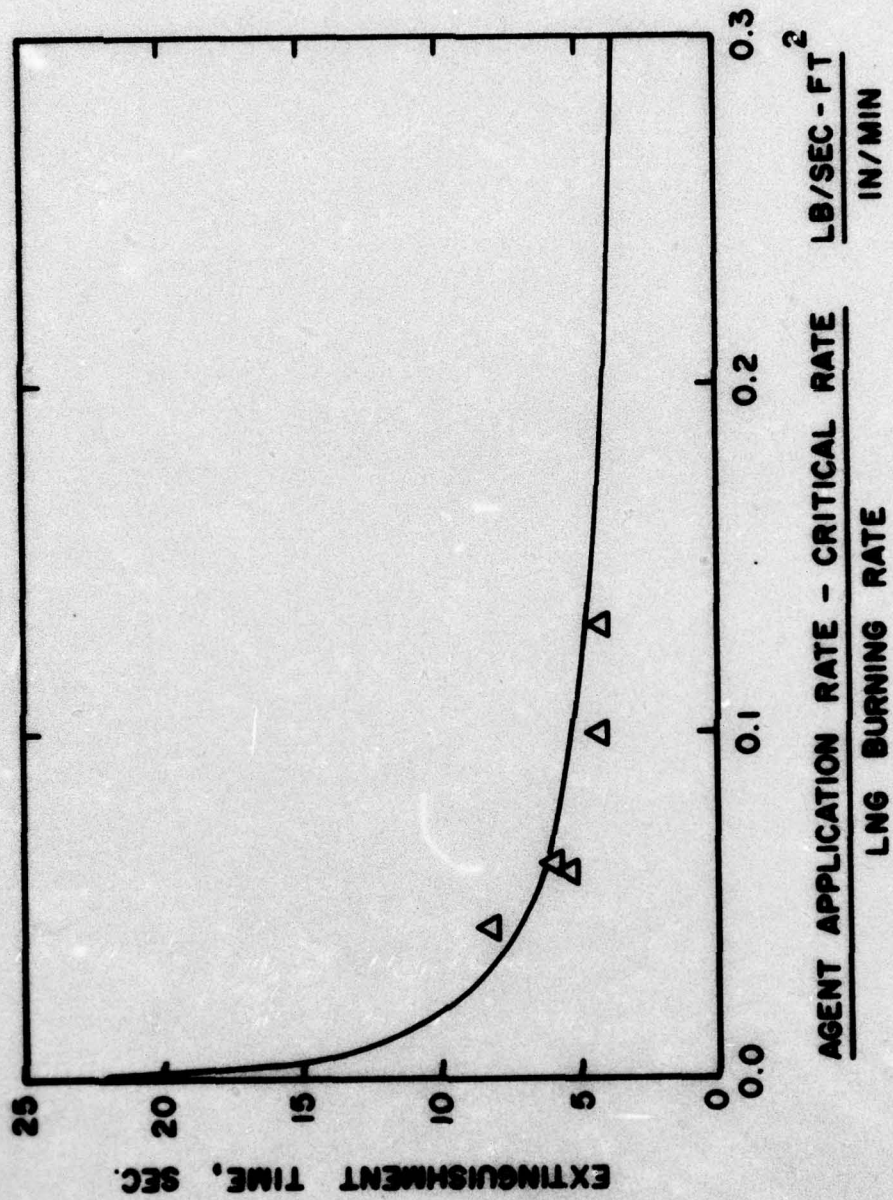

Figure 3. Calculated extinguishment time as a function of sodium bicarbonate dry chemical application rate (time averaged) and LNG burning rate. Individual points are data on extinguishing obstructed fires in this test series.

An identical procedure was used to analyze the extinguishment data for potassium bicarbonate powder. Fourteen data points were used for the regression analysis; seven tests were excluded since the fires were not extinguished. The calculated best fit for these data is given by Equation 3.

$$t = 4.0 \left( \frac{A - 0.007}{B} \right)^{-0.22} \quad (3)$$

Calculated extinguishment time as a function-of LNG burning rate and potassium bicarbonate excess application rate is shown in Figure 5. Data from the USCG tests are included in the figure. The relationship between the calculated and observed extinguishment times are shown in Figure 6.

For urea-potassium bicarbonate agent, 18 data points were used in the regression analysis; two tests were excluded because the fires were not extinguished. The calculated best fit for these data is given by Equation 4.

$$t = 1.3 \left( \frac{A - 0.002}{B} \right)^{-0.42} \quad (4)$$

The results for urea-potassium bicarbonate agent are shown in Figure 7. Data from the USCG tests with an LNG burning rate of 0.4 in/min are included in the figure. The relationship between the calculated and observed extinguishment times are shown in Figure 8. Figure 9 shows the calculated extinguishment times for an LNG fire burning at 1.0 in/min as a function of application rate for the three dry chemical types tested.

It is generally accepted that to extinguish an LNG fire in a relatively long fixed time (i.e., greater than 10 sec) the rate of application required for urea-potassium bicarbonate will be less than that required for sodium bicarbonate and that the value for potassium bicarbonate will be intermediate. Shorter extinguishment times (i.e., less than 5 sec) would require nearly equal application rates for all three dry chemical types. This conclusion is generally borne out in Figures 3, 5, and 7 except that the curve for potassium bicarbonate shows longer than expected extinguishment times at the higher application rates. This

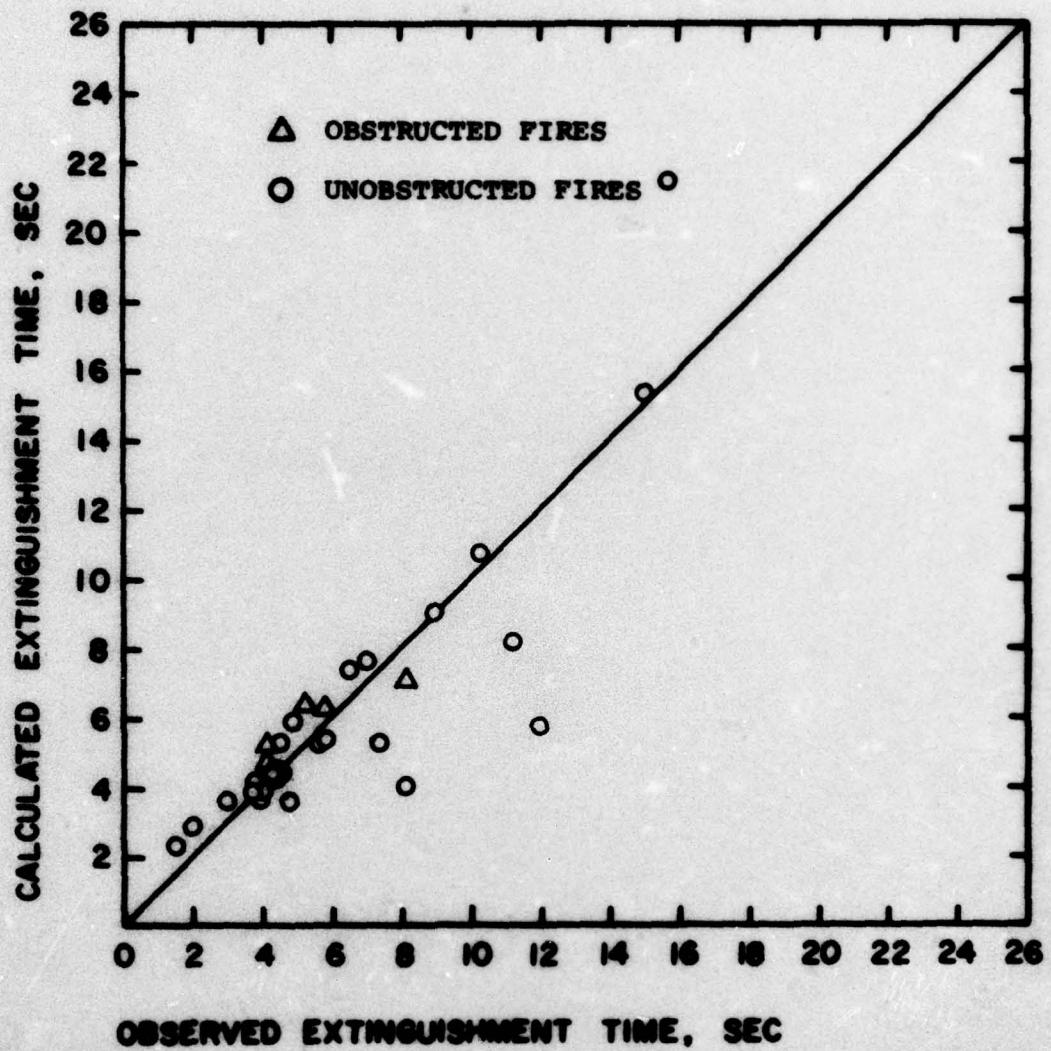

Figure 4. Comparison of calculated and observed extinguishment times for sodium bicarbonate agent on LNG fires.

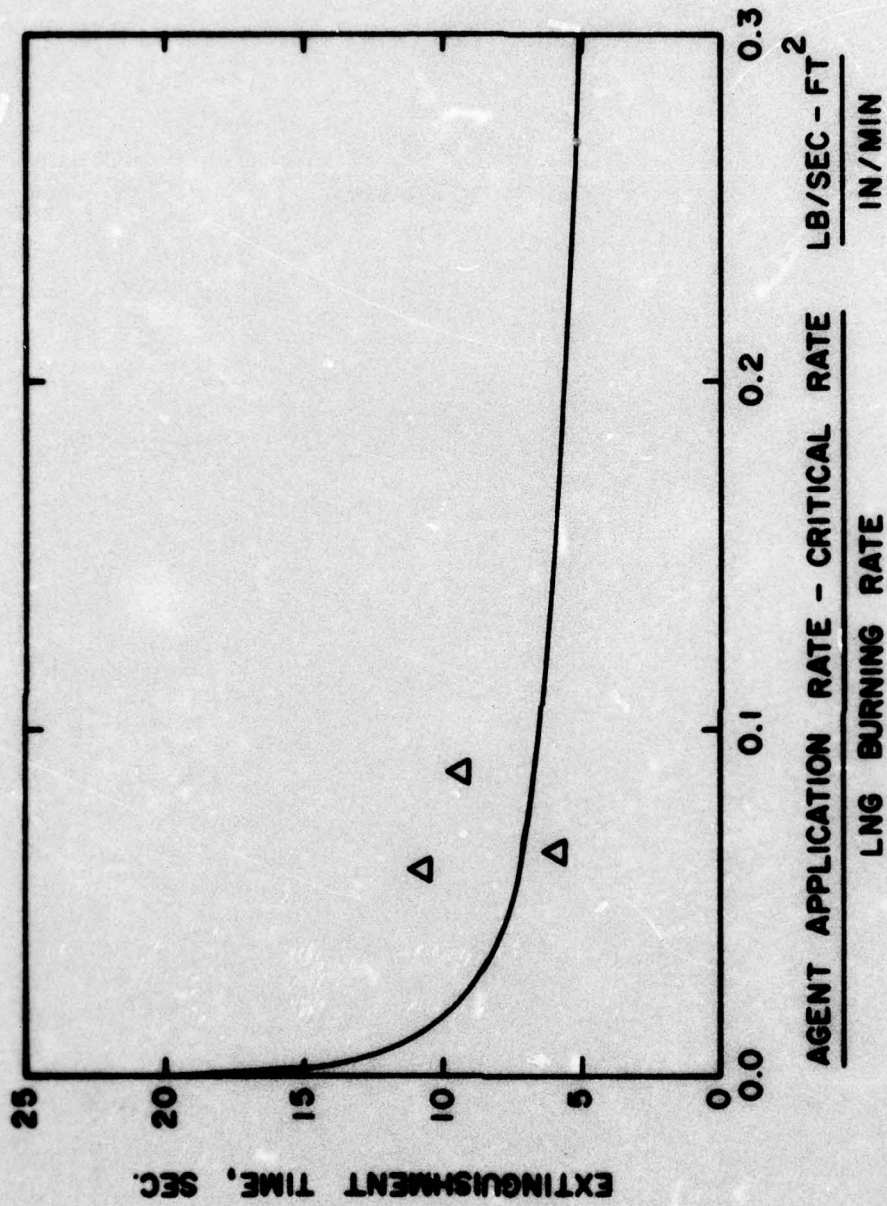

Figure 5. Calculated extinguishment time as a function of potassium bicarbonate dry chemical application rate (time averaged) and LNG burning rate. Individual points are data on extinguishing obstructed fires in this test series.

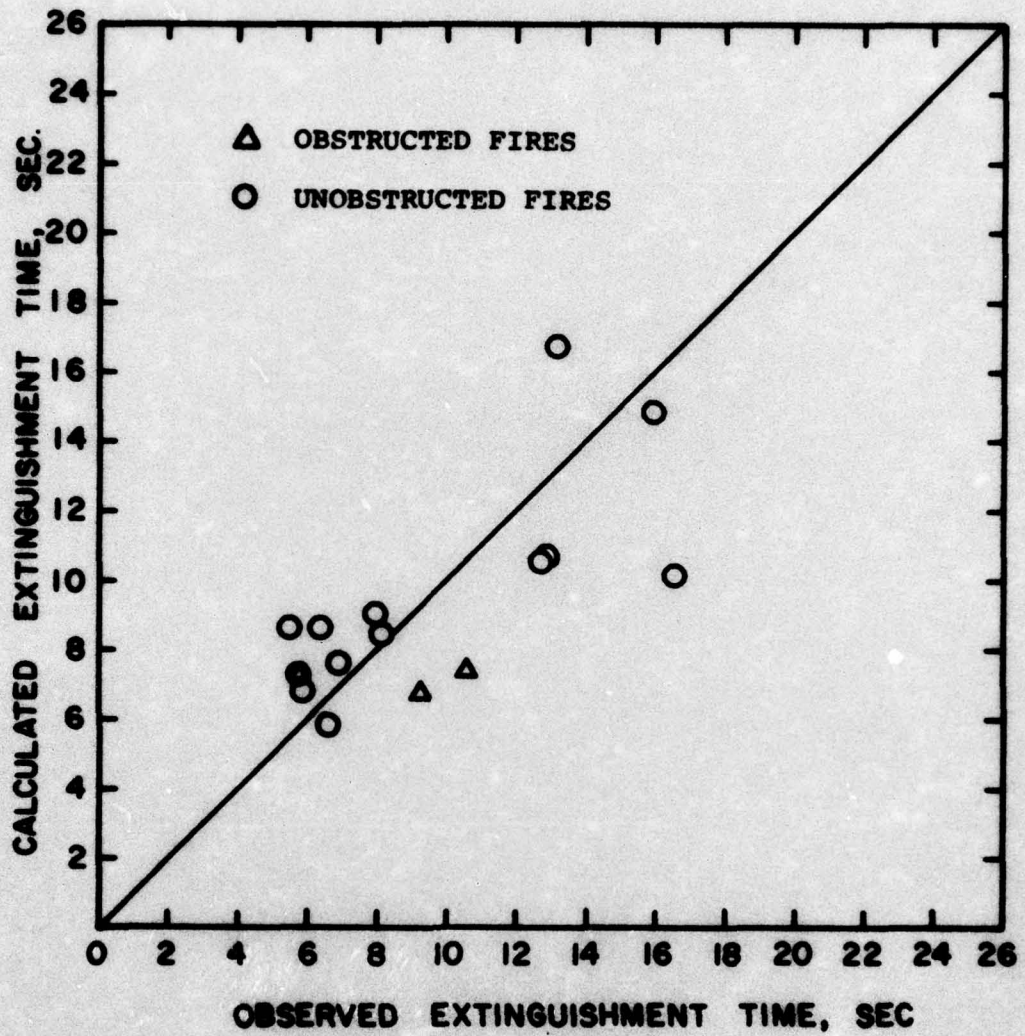

Figure 6. Comparison of calculated and observed extinguishment times for potassium bicarbonate agent on LNG fires.

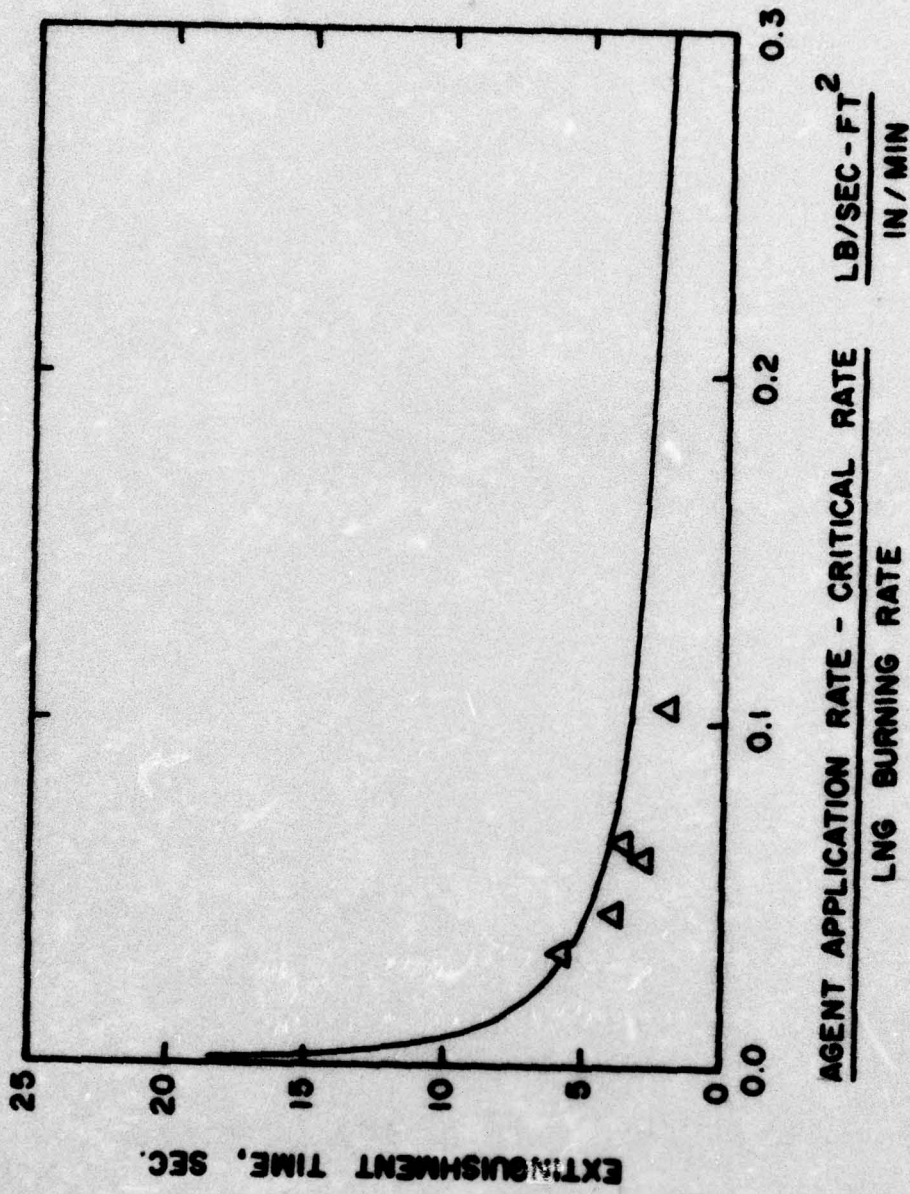
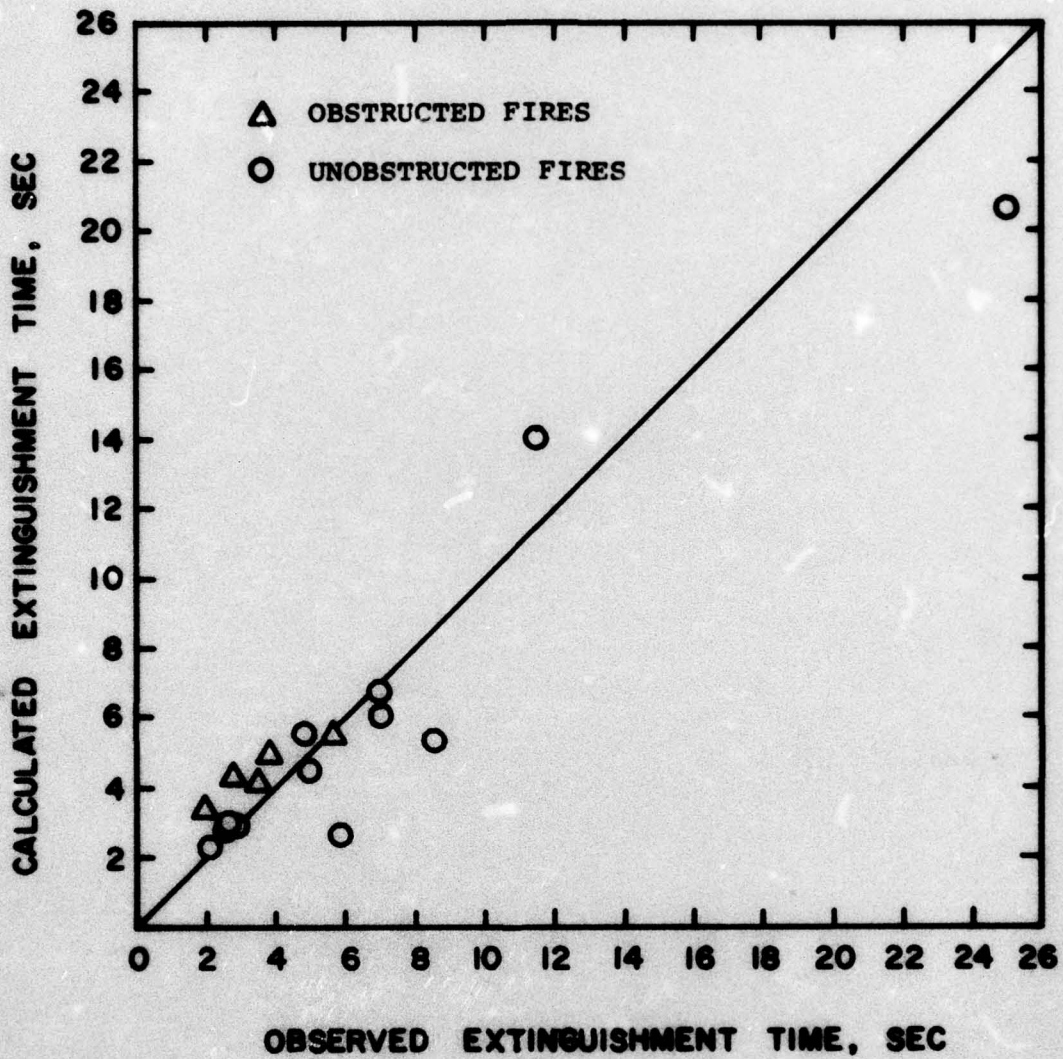

Figure 7. Calculated extinguishment time as a function of urea-potassium bicarbonate dry chemical application rate (time averaged) and LNG burning rate. Individual points are data on extinguishing obstructed fires in this test series.



**Figure 8.** Comparison of calculated and observed extinguishment times for urea-potassium bicarbonate agent on LNG fires.

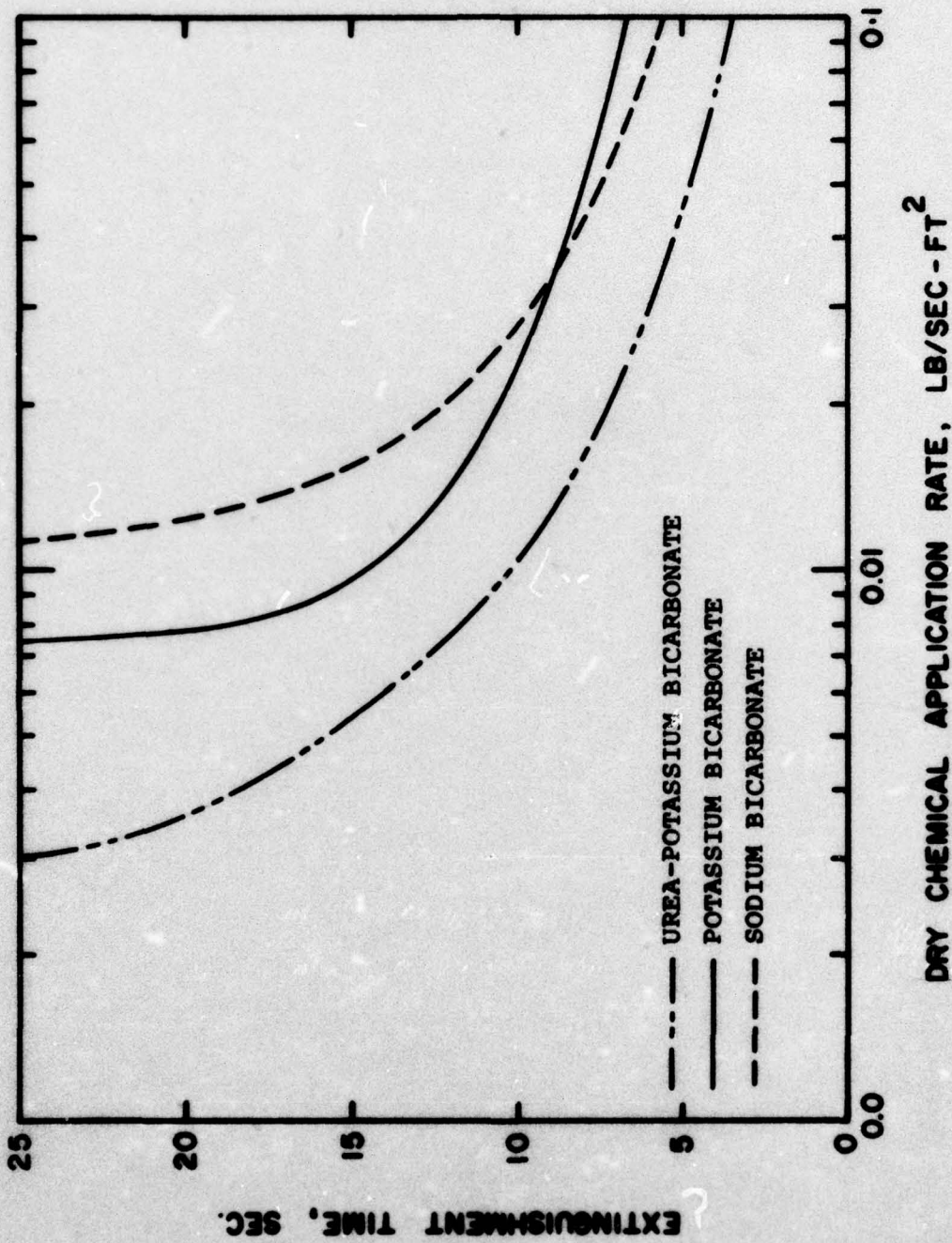

Figure 9. Calculated extinguishment times as a function of agent application rate for LNG fires burning at 1.0 in/min liquid level regression rate.

difference is probably caused by the smaller number of data points available for use in the regression analysis (none available for extinguishment times less than 5.5 sec) and the relatively large scatter in the data. The multiple regression analysis of the potassium bicarbonate extinguishment data yields a lower multiple regression coefficient and a much lower "F" value than is found for either of the other two dry chemical types tested. Therefore, less confidence can be placed in the ability of the regression analysis equation for potassium bicarbonate to accurately extrapolate extinguishment times beyond the limits of the data. More information on the statistical analysis of the data is presented in the Appendix.

#### EXTINGUISHMENT OF FIRES FROM LNG ON WATER

Four extinguishment trial tests for LNG fires burning on water were conducted to determine whether the presence of a shallow water pool in a containment would cause fire behavior that would alter the effective action of dry chemical agents. The tests were conducted in the previously described 10 ft x 10 ft concrete pit containing about 10 inches of water and no metal obstructions. LNG was charged into the pit at the highest possible truck unloading rate, about 300 GPM, to attempt to minimize pit fill time and thus ice formation.

It was anticipated that the LNG boil-off rates during these tests would be about 1 in/min due to heat transfer from the water plus about 0.4 in/min due to radiation feedback from the fire column. If observed extinguishment times were not substantially greater than times calculated on the basis of anticipated boil-off rates, extinguishing agent effectiveness could be considered unaffected. Because the controlling boil-off mechanism was expected to be heat input from the water in these tests, the 30 second pre-burn used in the obstructed fires was eliminated to conserve as much LNG as possible. The results of the four extinguishment tests are listed in Table 3 and compared to predicted extinguishment times computed from Equations 1, 2, and 3. It should be noted that the extinguishment attempts were conducted sequentially in the order indicated by the test number.

TABLE 3  
SUMMARY OF EXTINGUISHMENT TRIALS FOR LNG FIRES ON WATER

Test No.	Actual Order Of Tests	LNG Pool Area (ft <sup>2</sup> )	Dry Chemical Type	Dry Chemical Equipment	Dry Chemical Application Rate (lb/sec-ft <sup>2</sup> )	Extinguishment Time (sec)	
						Actual	Predicted*
29	16	100	U-PB	1 portable	0.013	4.7	10.0
31	17	100	SB	1 handline	0.027	3.1	11.3
32	18	100	PB	1 handline	0.040	2.4	9.1
32A	19	100	PB	1 portable	0.014	2.4	12.8

\*Predicted extinguishment time is for a burning rate of 1.4 in/min.

Extinguishment time for the first extinguishment trial was significantly shorter than the predicted extinguishment time (4.7 versus 10.0 sec, respectively). As testing progressed, the differences between predicted and actual extinguishment time became even more pronounced, always with shorter actual times. The test films also show that the flame became shorter as testing progressed. The obvious reduction in vaporization rate indicates that ice formed on the water and reduced the water surface area available for LNG contact and evaporation. Consequently, even in the first trial the burning rate was under 0.5 in/min instead of the 1.4 in/min rate used for the predictions. With the reduced burning rate, the dry chemical required for extinguishment was reduced. At the completion of testing, the entire 10 ft x 10 ft pit was bridged over with ice. In at least the last trial, a portion of the pool area was occupied by humps of ice rather than LNG, so that the fire area was a little less than 100 ft<sup>2</sup>, which accounts for the ease with which that fire was extinguished.

At the outset of these tests it was recognized that ice would form in the pit, but it was anticipated that the rate of ice formation would be less than that observed. The rate of ice formation in these tests probably was increased by turbulence from the LNG boiling which induced foaming freezing. In an effort to gain more information on ice formation for LNG spilled onto water, residual LNG in the tanker at the end of the test program was dumped onto a 30 ft x 40 ft pond containing 3 to 4 inches of water at a temperature of about 9°C. The LNG was spilled about 3 1/2 ft from the pond's earthen walls. It was observed that ice formed on the water surface as LNG was spilled. This observation is consistent with the heat capacity available in such shallow water pools at already low temperatures. On open water, unconfined LNG spills may not form ice as rapidly because of pool depth and the effect of wave action which should slow solid-sheet ice formation.

The data again demonstrate that LNG spill fires can be extinguished at application rates consistent with the fuel burning

rate. If necessary for life rescue or to protect equipment, an LNG fire on water can be extinguished using dry chemical. If a confined LNG pool resides on shallow water for even a short time before ignition occurs, extinguishment can be accomplished with low agent flow rates provided that extinguishment is attempted immediately after ignition occurs. Lower rate requirements are associated with longer LNG residence time before ignition. These observations are expected to be particularly true if the LNG pool is restrained from spreading shallowly over a large area.

## REDUCTION OF LNG VAPOR CONCENTRATIONS USING WATER SPRAYS

Water sprays have been suggested as an aid in dispersing vapors following an LNG spill. Some LNG facility designs have incorporated water sprays to reduce vapor concentrations if a spill occurs. All LNG ships and installations provide water for fire fighting which could also be used for water sprays. Thus, any improvement that can be provided by water sprays has potential application to all LNG marine facilities.

There are no published data that indicate the effectiveness of water sprays in dispersing LNG vapors. The tests described in this section were designed to determine whether some reduction of vapor concentrations from small spills could be effected by using water sprays. Two systems, fixed water nozzles and handheld fog nozzles, were tested. The general test procedure was to fill the specially-designed 10-foot diameter test pan with LNG and then measure flammable vapor concentrations downwind as increasing quantities of water were sprayed into the plume downwind of the pan. To increase the LNG boil-off rate and achieve higher initial concentrations, water was circulated through heating tubes located at the bottom of the test pan. During the tests, the following parameters were measured and recorded.

- 1) Gas concentrations (10 locations)
- 2) Wind velocity
- 3) Water pressure at the spray nozzles (to determine water flow rate).

Figures 10 and 11 show the locations of the gas sensors during the water spray tests. The circled numbers refer to gas sensor numbers. Generally, the gas sensors were placed in their final locations after the LNG pool was filled to insure location on the downwind azimuth.

Gas concentrations from each location were measured by a catalytic bead gas sensor system with the output from the gas sensor continuously recorded on a strip chart recorder. A magnetic

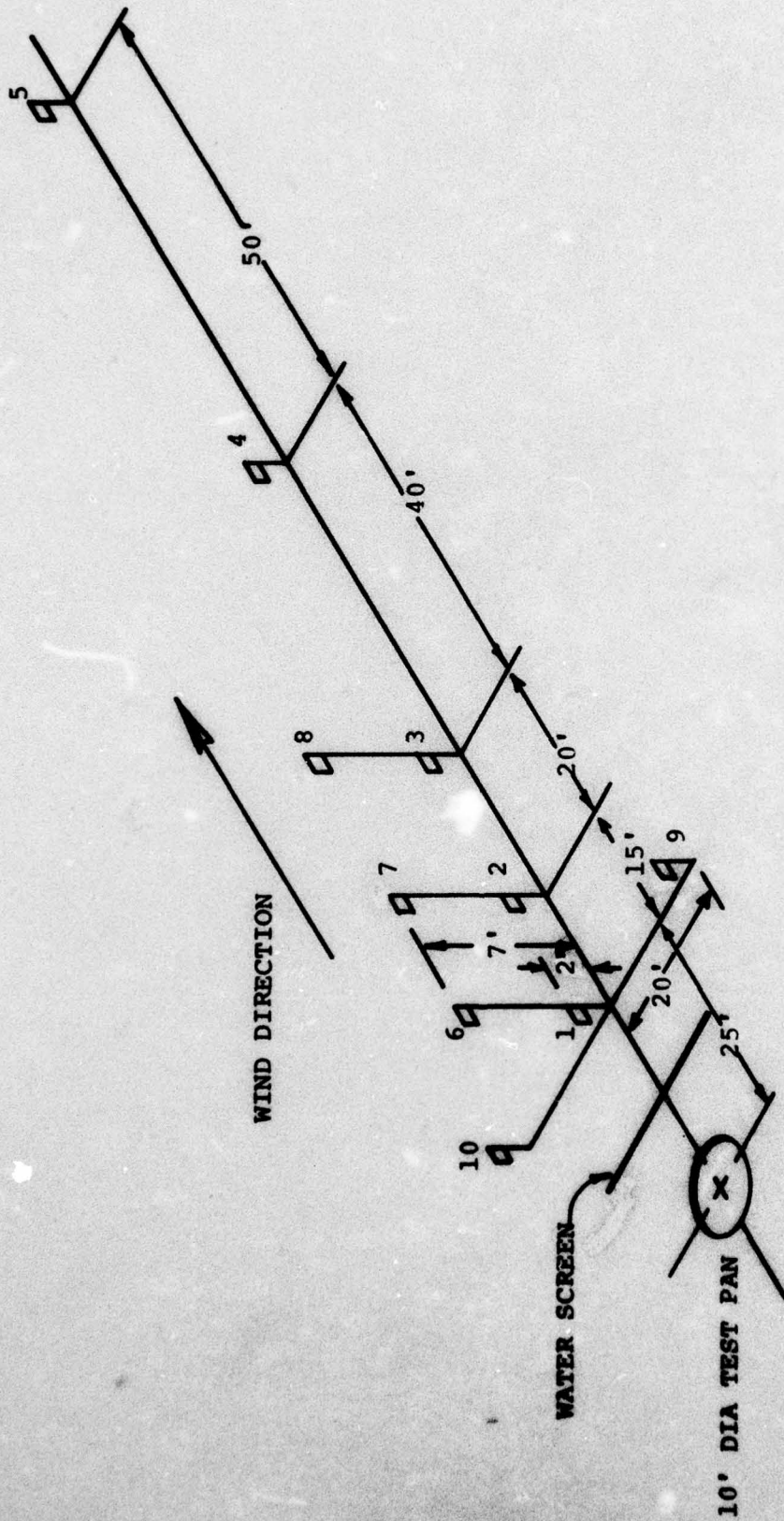

Figure 10. Gas sensor layout for vapor dispersion tests 1-4  
 (Vertical dimensions not to scale).

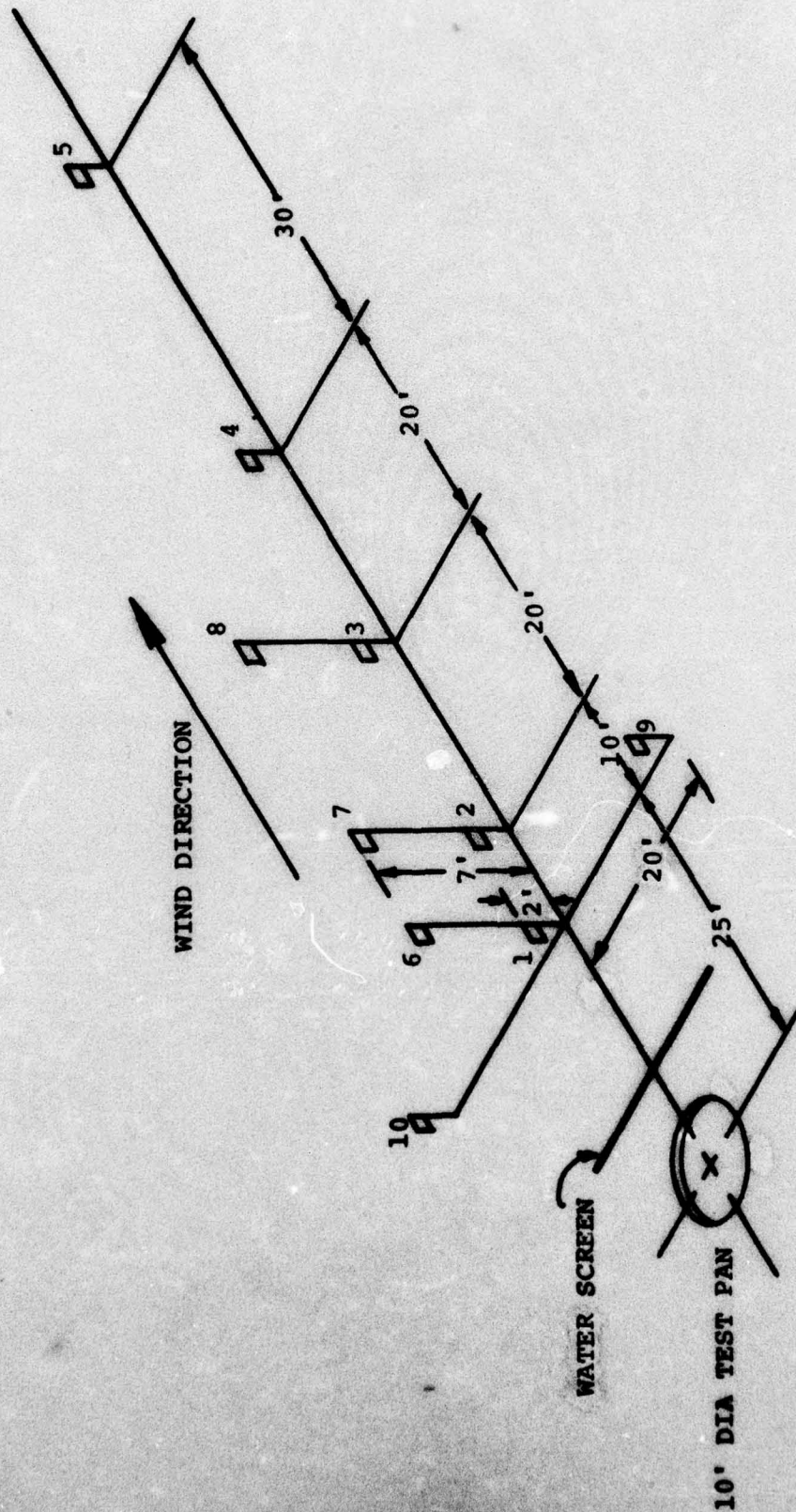

Figure 11. Gas sensor layout for vapor dispersion tests 5-12  
 (Vertical distances not to scale).

tape recording system was used for backup. The gas sensor system is designed to permit a mixture of combustible gas and air to contact heated catalytic beads that form part of a balanced bridge circuit. Rapid combination of combustible gas and oxygen on the surface of the catalytic beads increases the bead temperature, causing a change in the bead resistance and an imbalance in the bridge circuit. The imbalance is related to the gas concentration. The gas sensors are designed for use up to the lower flammable limit, about 5 percent for methane in air, but their response was found in earlier tests to be linear up to about 8 or 10 percent methane in air. At higher concentrations the response of the catalytic element reaches a peak and then decreases, decreasing its usefulness for measuring higher concentrations.

The calibration of the gas sensors is quite stable and usually does not change greatly over the period of a few weeks unless the sensor is damaged. However, in order to obtain data as accurately as possible, calibration checks were made before each test run using a specially-prepared standard gas containing 2.5 percent methane in air.

During the tests, the wind velocity averaged approximately 780 ft/min (9 MPH) with gusts up to 1500 ft/min (17 MPH). Thus gustiness and the crosswind turbulence cause fluctuations in the methane concentration readings which are then time-averaged to facilitate analysis. The time-average concentration is merely the integral of the concentration vs. time curve over a period divided by the time period. This calculation can be accomplished by finding the area under the concentration curve with a planimeter and dividing by the elapsed time, usually 5 to 10 minutes. This calculation is made directly from the recorded data on the strip charts for each sensor's readings.

Table 4 lists the water spray conditions during each test. During each of the water spray tests, the nozzle closest to the pool was located about 5.5 ft downwind from the lee edge of the pool. The second and third nozzles were about 10 inches and 20 inches downwind of the first nozzle, respectively. The nozzles were located about 1.5 ft below the edge of the LNG container, and

TABLE 4. SPRAY NOZZLES AND WATER FLOW RATES USED DURING DISPERSION TESTS.

Test	# of Nozzles	Orifice Size (in)	Pressure (psi)	Flow Rate* (GPM)	Total Flow Rate (GPM)
1	0	--	--	--	--
2	1	7/32	60	9.8	9.8
3	2	7/32, 7/32	60, 60	9.8, 9.8	19.6
4	3	7/32, 7/32, 19/64	60, 60, 60	9.8, 9.8, 19.6	39.2
5	0	--	--	--	--
6	1	3/8	80	33.0	33.0
7	2	3/8, 19/64	80, 85	33.0, 22.6	55.6
8	3	3/8, 19/64, 7/32	80, 85, 75	33.0, 22.6, 10.9	66.5
9	0	--	--	--	--
10	1	19/64	85	22.6	22.6
11	2	19/64, 19/64	85, 85	22.6, 22.6	45.2
12	3	19/64, 19/64, 19/64	85, 85, 75	22.6, 22.6, 21.5	66.7

\*Based on Manufacturer's Data

each produced a spray in the shape of a circular segment with a radius of 8 to 10 ft and an arc of 150 to 160 degrees. The first 3 ft of the spray was essentially a sheet of water, and the remaining 5 to 7 ft distance to the outer extent of the spray consisted primarily of water drops. Table 4 also includes the flow rates for each of the nozzles during each test, the number of nozzles used, and the total water flow rate. Movies of the tests show that the vapor plume did not flow around the fan-shaped water spray. Rather, the plume flowed through the turbulent zone created by the spray, and the mixing of vapor and air in the spray zone was apparent from the plume behavior.

Table 5 lists the time-average methane concentrations at the various gas sensors with the peak concentrations being shown in parentheses. The peak concentrations are the highest concentrations measured during the elapsed time over which the average concentrations were calculated. Concentrations at Sensors 5, 9, and 10 are not included in Table 5. The average concentrations at the Number 5 gas sensor were too low to be reliable. Gas Sensors 9 and 10, located off the downwind azimuth as shown in Figure 11, generally registered very low or zero concentrations except when the wind direction changed significantly. Such changes were infrequent and usually lasted less than 20 sec. If such a wind direction change occurred during the time of averaging of the downwind sensors, this change was recorded by either Sensor 9 or 10. The average concentrations of Sensors 9 and 10 are also too low to be reliable; however, recording of the concentrations of these sensors was an indicator that the vapor plume did not have a tendency to go around the water spray. This behavior would be expected because the water spray was not solid except for within 2 or 3 ft of the nozzles.

The missing points indicate sensor failures, most of which were due to water from the nozzles shorting out the electrical leads to the sensors or plugging the diffusion heads on the sensors. Therefore, most of the missing points occur at the sensors closest to the water spray. Any sensor failures due to water resulted in a zero indicated concentration.

TABLE 5. GAS CONCENTRATIONS MEASURED DURING DISPERSION TESTS

Test #	Sensor 1	Sensor 2	Sensor 3	Sensor 4	Sensor 6	Sensor 7	Sensor 8
1	.982 (1.71)	.382 (.96)	.218 (.71)	.095 (.40)	.160 (1.42)	--	.178 (.6)
2	.668 (1.31)	.265 (.70)	.134 (.46)	.053 (.20)	.183 (.74)	--	.138 (.46)
3	--	--	.101 (.37)	.035 (.20)	--	--	.116 (.46)
4	--	--	.102 (.38)	.045 (.16)	--	--	.13 (.50)
5	--	.533 (1.3)	.328 (1.80)	.267 (1.0)	.141 (.89)	.405 (1.08)	.25 (.67)
6	--	.289 (.7)	.12 (.59)	.128 (.45)	.156 (.70)	.277 (.7)	.134 (.4)
7	--	.142 (.62)	.079 (.39)	.107 (.43)	.194 (.60)	.243 (.60)	.098 (.36)
8	--	.166 (.56)	.082 (.33)	.077 (.31)	.210 (.51)	.22 (.45)	.098 (.29)
9	.676 (1.84)	.288 (1.0)	.145 (.73)	.105 (.54)	.168 (.96)	.396 (1.05)	.128 (.4)

TABLE 5. GAS CONCENTRATIONS MEASURED DURING DISPERSION TESTS--cont.

Test #	Sensor 1	Sensor 2	Sensor 3	Sensor 4	Sensor 6	Sensor 7	Sensor 8
10	.731 (1.34)	.218 (.54)	.102 (.4)	.100 (.28)	.224 (.66)	.375 (.83)	.087 (.32)
11	--	.141 (.4)	--	.046 (.20)	.229 (.6)	.211 (.525)	.083 (.26)
12	--	--	--	--	.180 (.48)	.10 (.5)	.026 (.16)

Figures 12 and 13 show the average concentrations measured during Tests 1-4, both before and after application of water sprays. Each figure compares the concentration before water spray was initiated to the concentration after one or more nozzles were activated. In most cases the methane concentration decreased after water spray was initiated. Figure 12 shows the concentrations for sensors located 2 ft above ground level. In Test 1, before water spray was initiated, the average concentration decreased from about 0.9 percent at 25 ft from the pool center to about 0.09 percent at 100 ft from the pool center. The slope of the concentration vs distance curve in Figure 12 is within the range of slopes found in earlier tests at the same site using similar techniques and conditions, although the absolute concentrations are less because of higher wind speeds and lower evaporation rates in the current tests. After the first water spray was turned on, the average methane concentration decreased by about 40 percent, with an additional decrease of about 10 to 15 percent of the original concentration as the water flow rate was doubled and then tripled by the activation of the second and third water sprays.

Figure 13 shows the average methane concentrations at the 7 ft elevation both before and after water sprays. Although sensors at only two locations resulted in usable data, the results are indicative of the plume behavior. The points 25 ft from the pool edge showed a small rise in methane concentration following activation of the water spray, the points 65 ft from the pool center showed a decrease, with the greatest decrease occurring after activation of the first nozzle.

The second and third series of tests resulted in similar behavior, as shown in Figures 14 through 17, with some additional trends. In Figure 14, the decrease in concentration after activation of the first nozzle was about the same as that following the activation of the third nozzle in Figure 12 at the 35 ft distance from the pool center; both of these conditions used similar total water flow rates. The reductions compare reasonably well at other distances from the pool, except for the data points at 75 ft, which appear anomalous. One likely reason for the anomaly is a possible

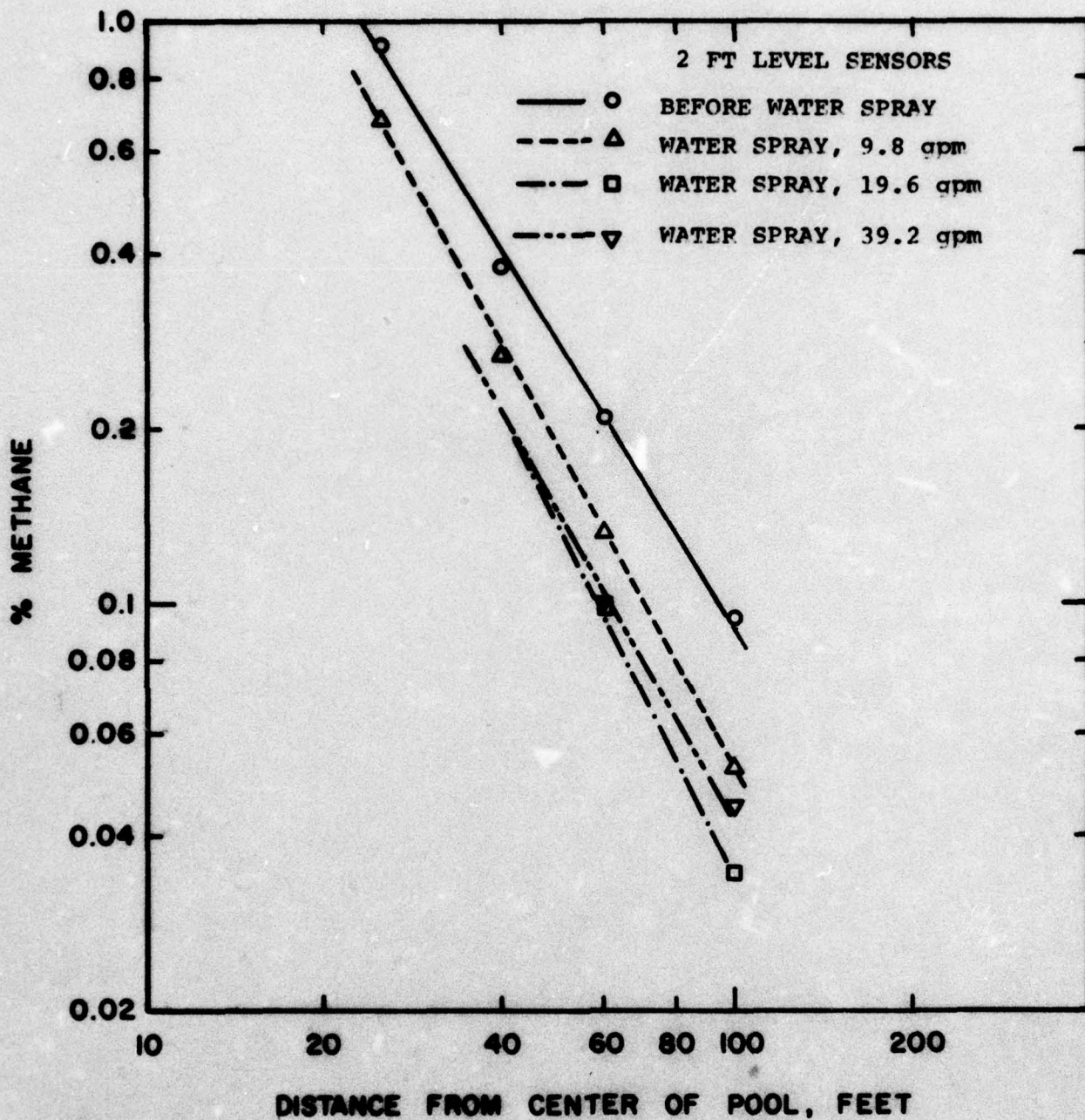

Figure 12. Average concentration as a function of distance. Tests 1-4.

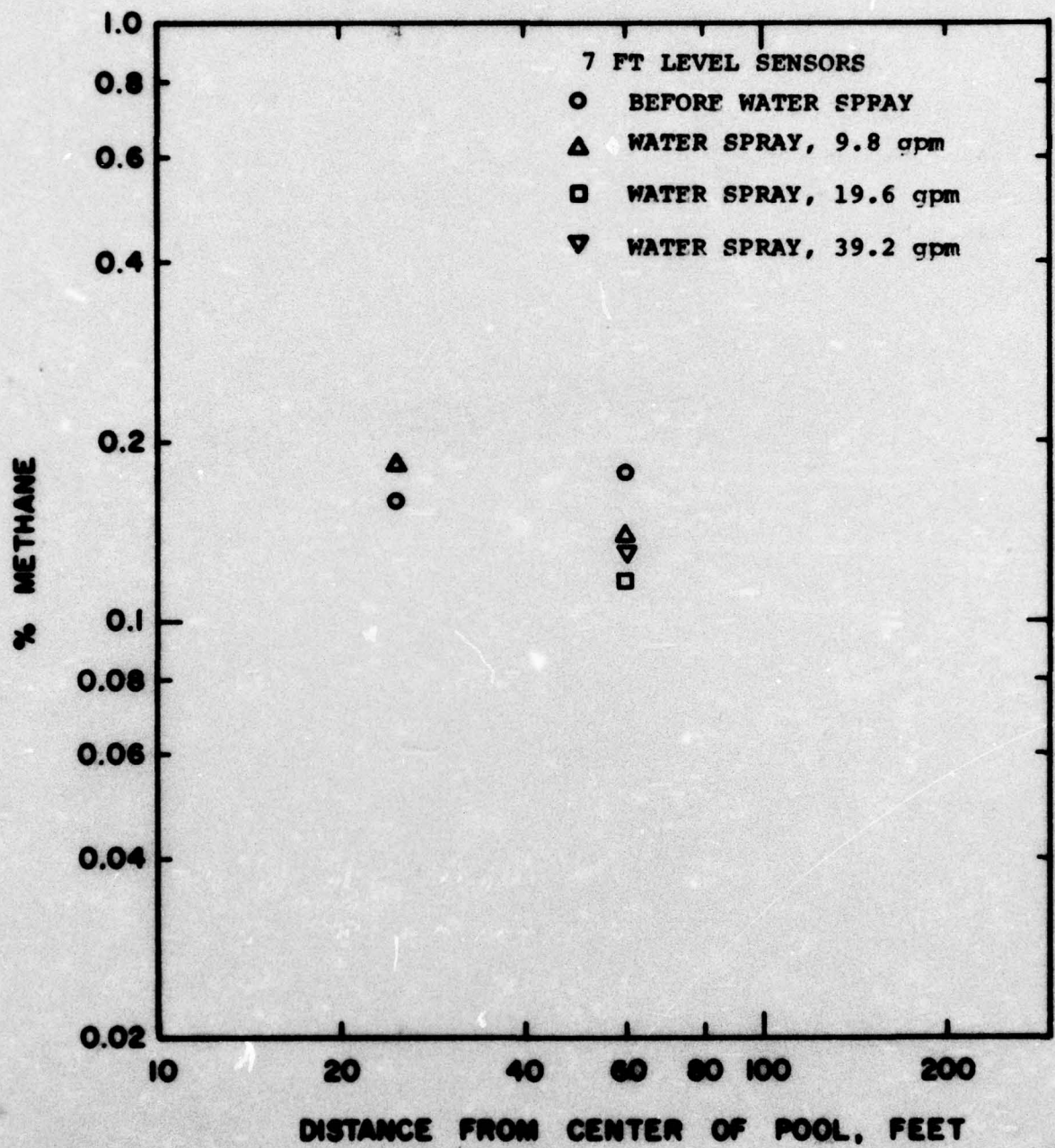

Figure 13. Average concentration as a function of distance. Tests 1-4.

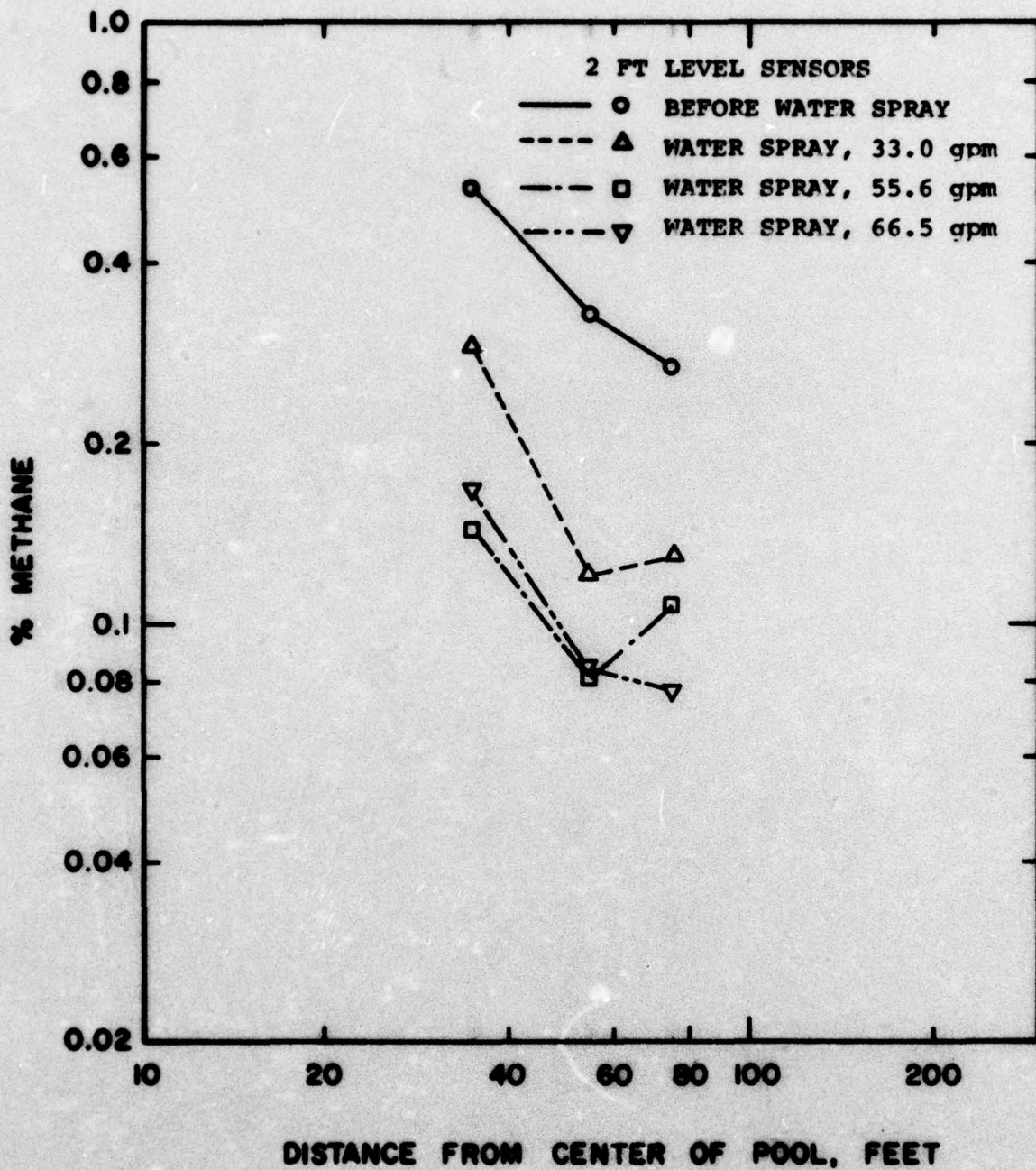

Figure 14. Average concentration as a function of distance. Tests 5-8.

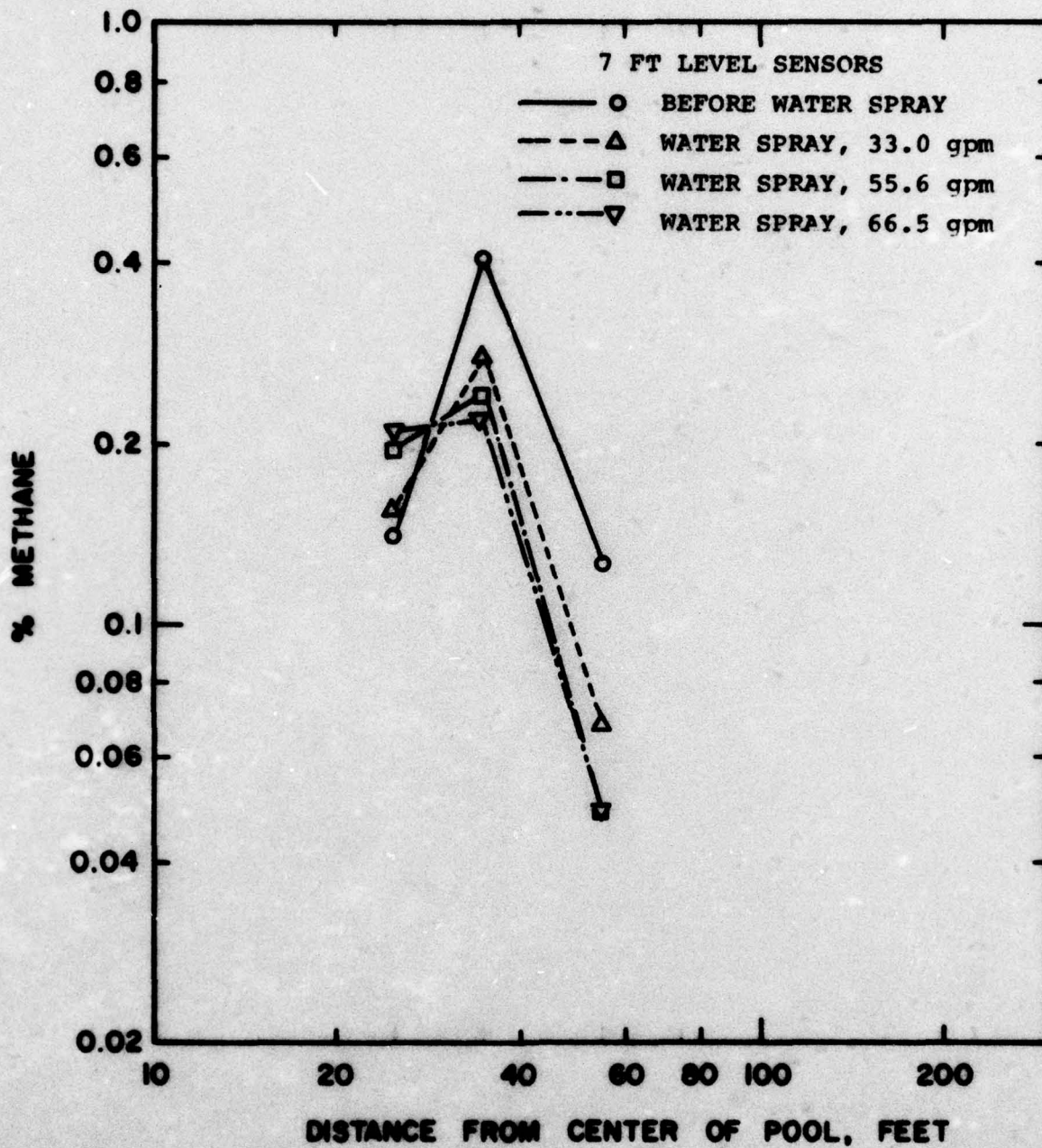

Figure 15. Average concentration as a function of distance. Tests 5-8.

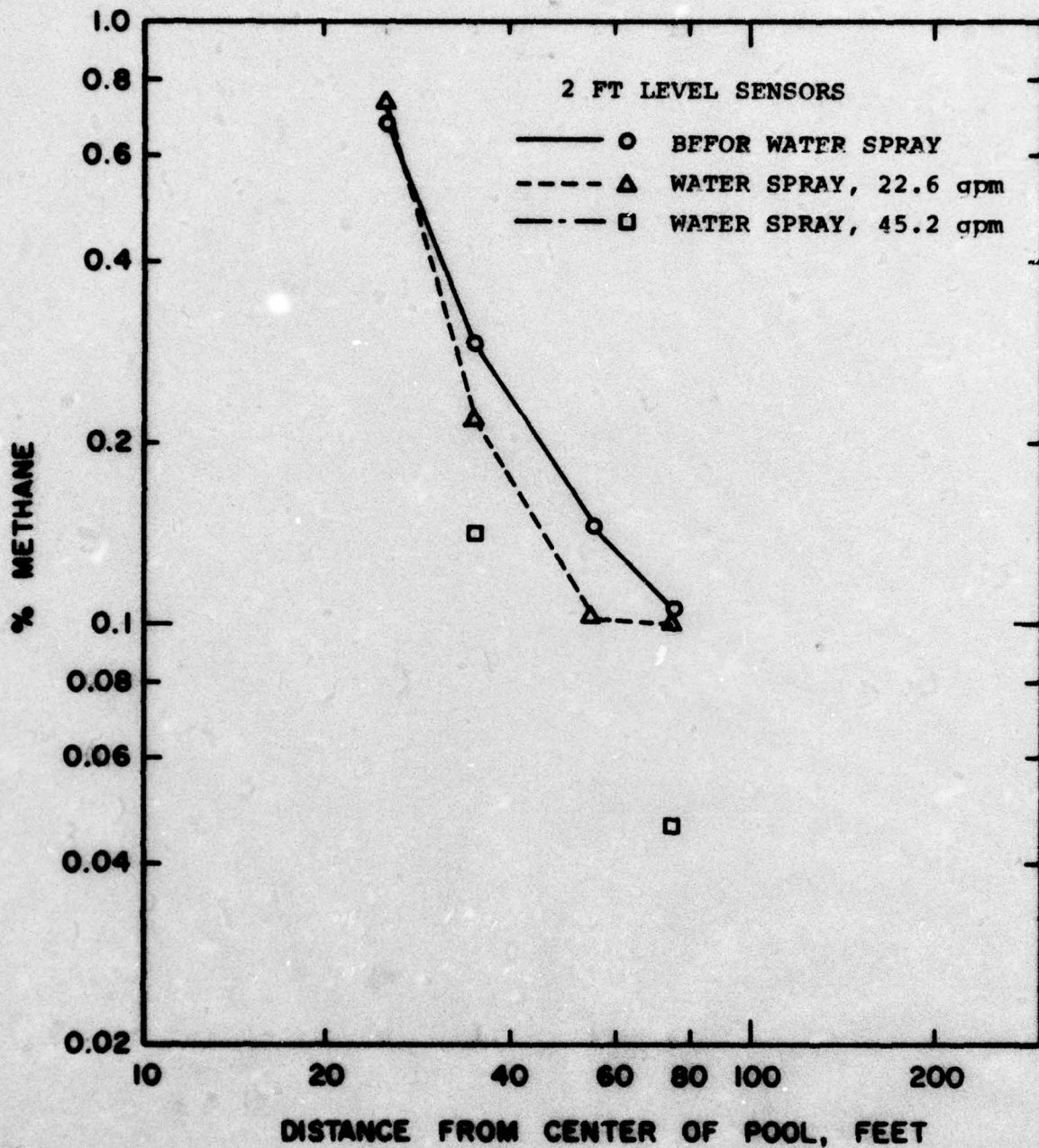

Figure 16. Average concentration as a function of distance. Tests 9-12.

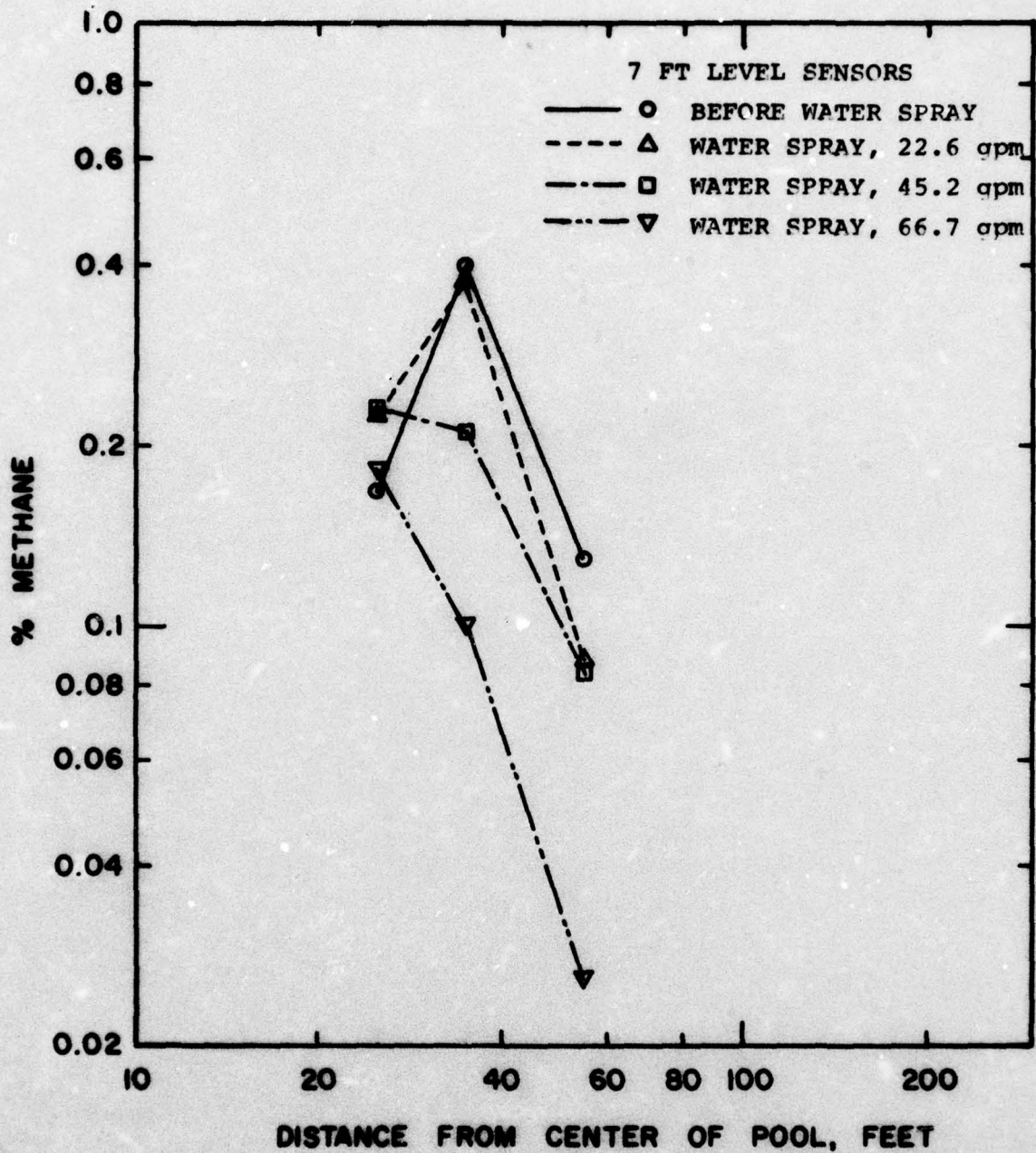

Figure 17. Average concentration as a function of distance. Tests 9-12.

zero error in the data. If a zero shift of less than 0.05 percent methane occurred, the data points shown would fall essentially on an extrapolation of a straight line drawn through the data points at 35 and 55 ft. Since such a small error is less than overall instrument accuracy, it seems acceptable to assume that a zero shift is the cause of the anomaly in the data. Under that assumption, the application of higher water spray rates reduces the concentration downwind of the spill until flow rates of 50 to 60 gpm are reached.

Figure 15 shows that without water spray the methane concentration near the pool is less than that at intermediate distances at the 7 ft elevation. This result is expected on the basis of a simple theoretical analysis, because the plume height increases as the vapor is mixed with air downwind of the pool. As shown in Figure 18, as the water spray is activated, the vapor is mixed more rapidly with the air near the pool, so the concentration near the pool is increased at the 7 ft elevation. Since the vapor is dispersed through a greater volume of air, the concentrations at greater distances from the pool are reduced by spraying water into the plume. Figure 17 shows that under some spray conditions the concentrations at the 7 ft elevation and intermediate distances may be reduced until they are smaller than those near the pool.

While it should be obvious that a dozen tests using a single pool size and evaporation rate cannot provide a quantitative basis for calculating vapor concentration reductions for all conditions of practical interest, they do indicate that concentration reductions do occur and show the mechanism causing the reduction. Two mechanisms appear to be likely candidates: heating the vapor plume thereby causing it to rise, and increasing mechanical turbulence which causes improved mixing. Both theoretical analysis and observation of the tests lead to the conclusion that the improved mixing is due to mechanical turbulence. The reasons are as follows:

1. The slope of the concentration vs distance curves are about the same before and after the activation of water sprays. Had significant heating occurred, the slopes would be different with the concentrations after spray decreasing more rapidly due

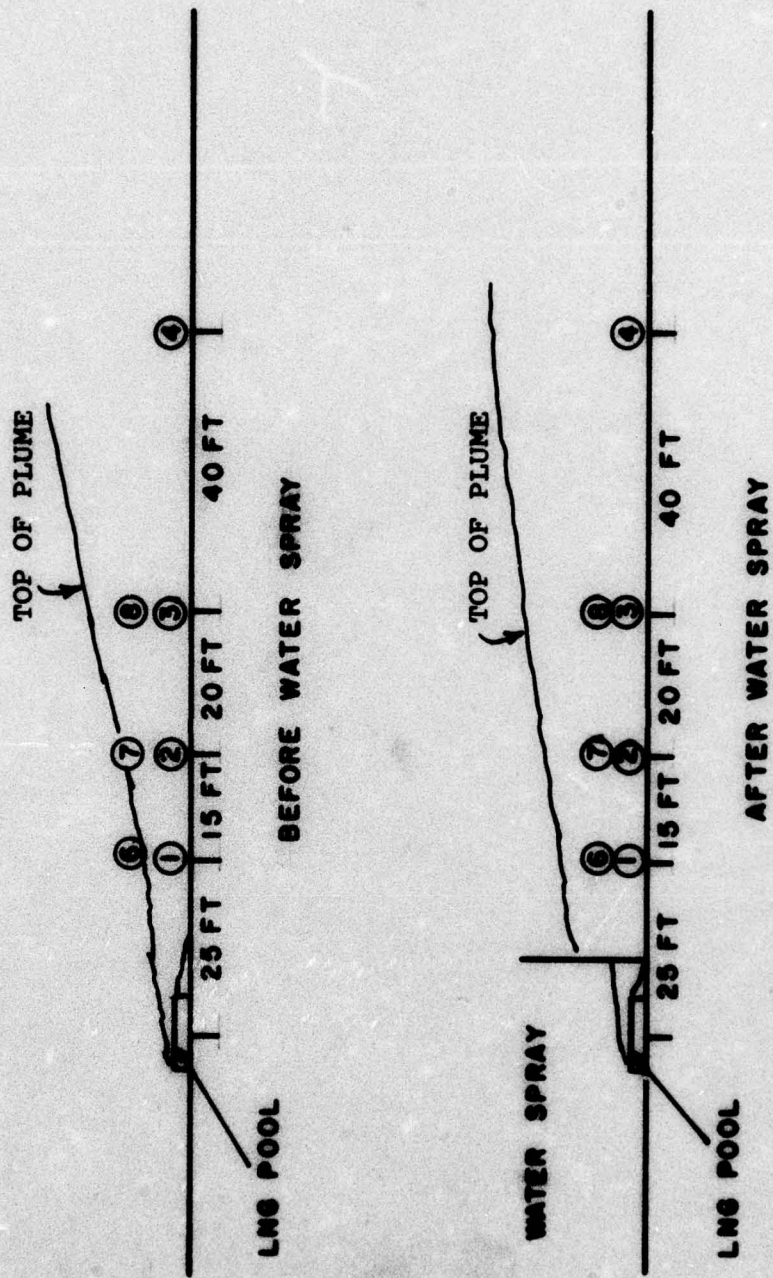

Figure 18. Illustration of mixing effect of water spray.

to plume rise. The behavior exhibited is similar to that expected if the plumes had originated farther upwind from the measuring point, i.e., as though the pool had been moved upwind. Such a result indicates purely mechanical mixing.

2. The water temperature in the spray was usually near and sometimes below the ambient air temperature. Since the average methane concentrations were less than one percent, the plume temperatures must have been near ambient temperatures. Therefore, little or no heating of the plume could result.
3. Movies taken during the tests show the plume passing through the water spray. The enhanced turbulence is also apparent.

Figures 19 through 24 show the peak or maximum concentrations measured at each point for all the tests. They show generally the same behavior as the average concentrations, except that they are two to three times as great as the average concentrations. This result is generally the same as found in previous studies.

Additional tests were run in which fog nozzles were used to spray water into the plume. The results were similar to those for the water sprays.

Even though a general basis for design of water spray systems for vapor concentration reduction cannot be developed quantitatively on the basis of these tests, the results show that water sprays can be effective in reducing the flammable plume size downwind of an LNG spill. The effect is primarily due to mechanical turbulence, so the water sprays should be applied in such a fashion as to provide maximum turbulence in the vapor zone, particularly in the vertical region near the top of the plume. Care should be taken not to spray water into the LNG pool, which would increase the boil-off rate and the concentrations in the air. Water sprays are practically effective for smaller, confined spills; larger spills will require spray systems that are too large to be practical.

CSL.

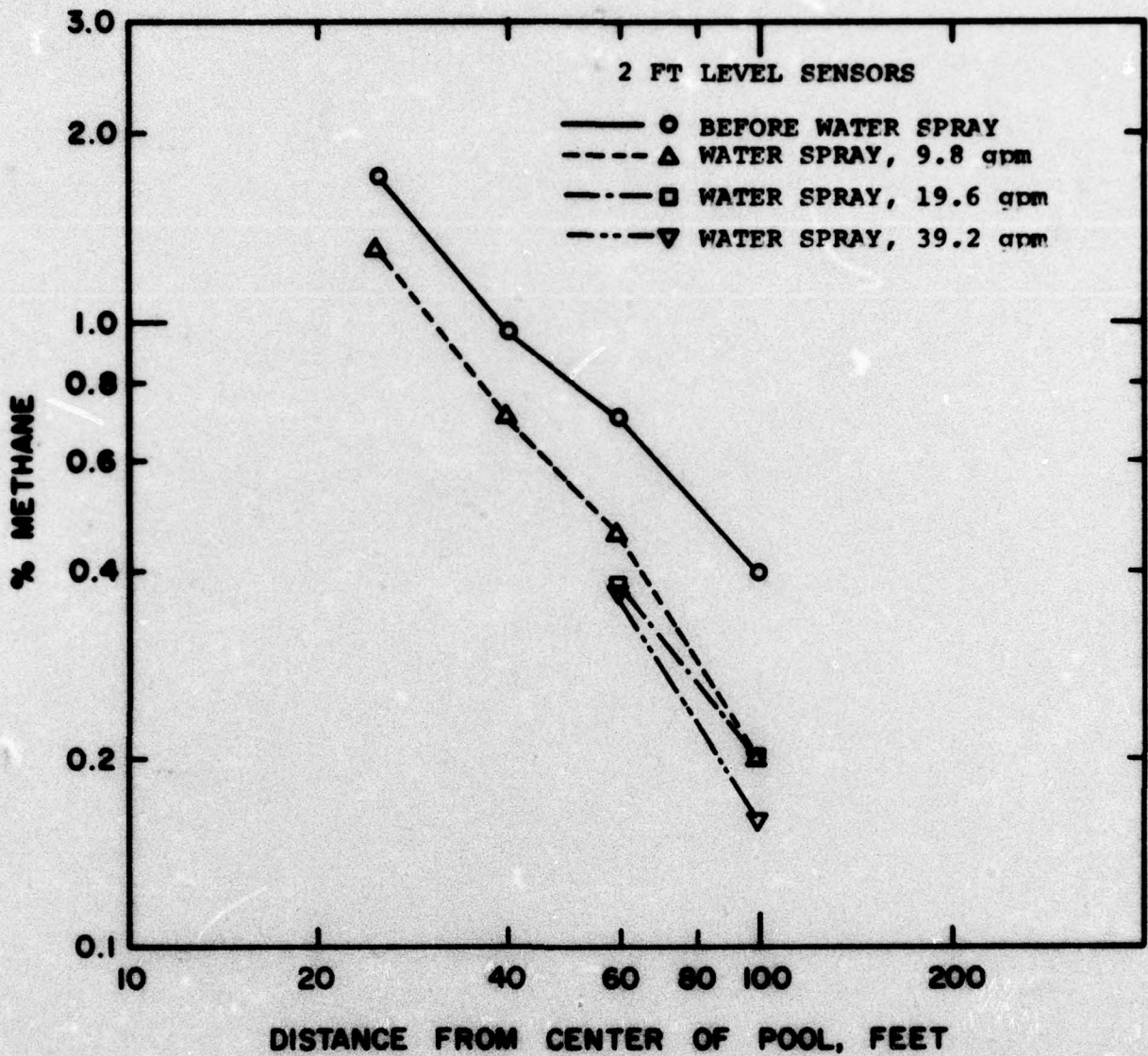

Figure 19. Peak concentrations as a function of distance. Tests 1-4.

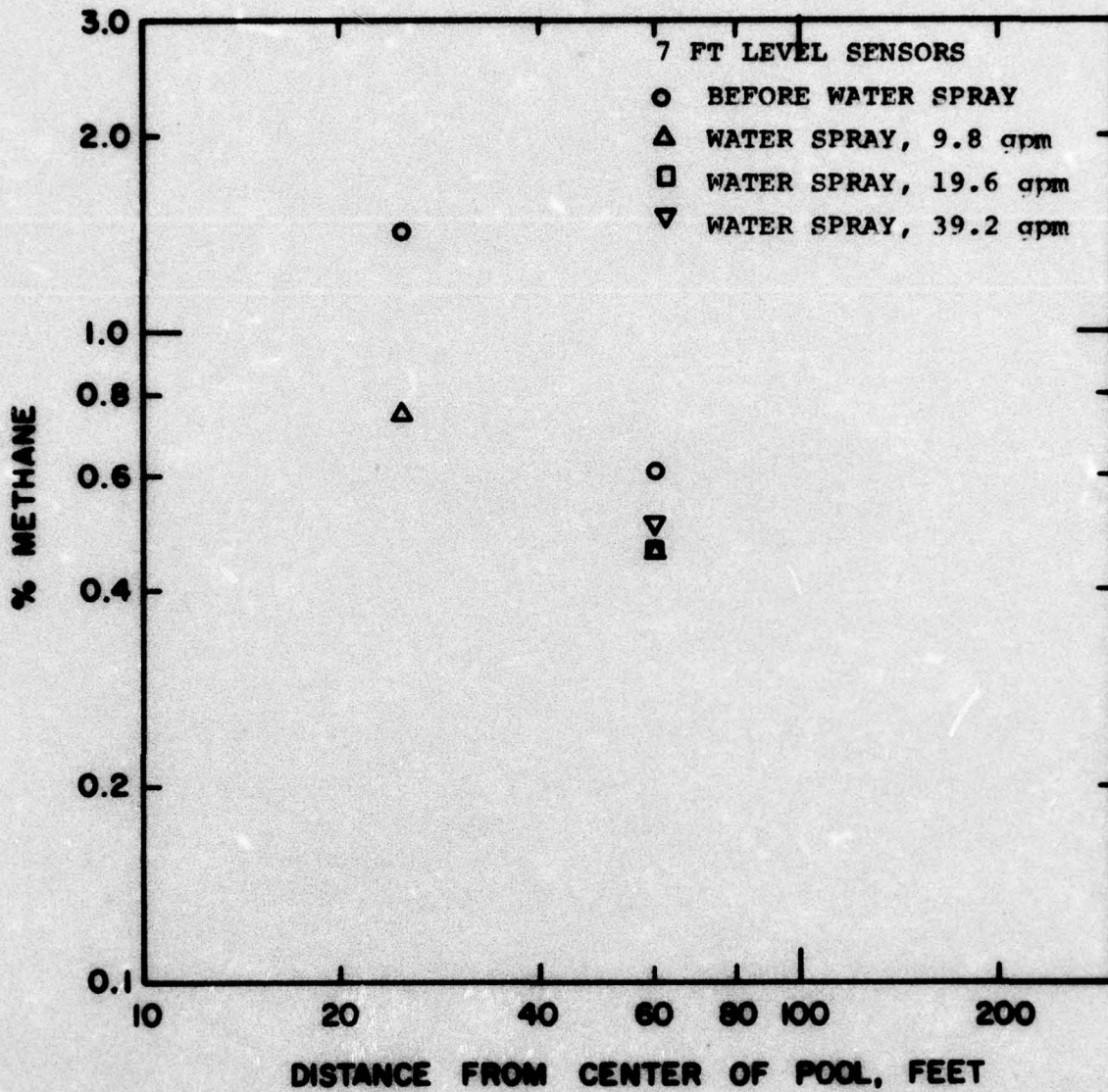

Figure 20. Peak concentrations as a function of distance. Tests 1-4.

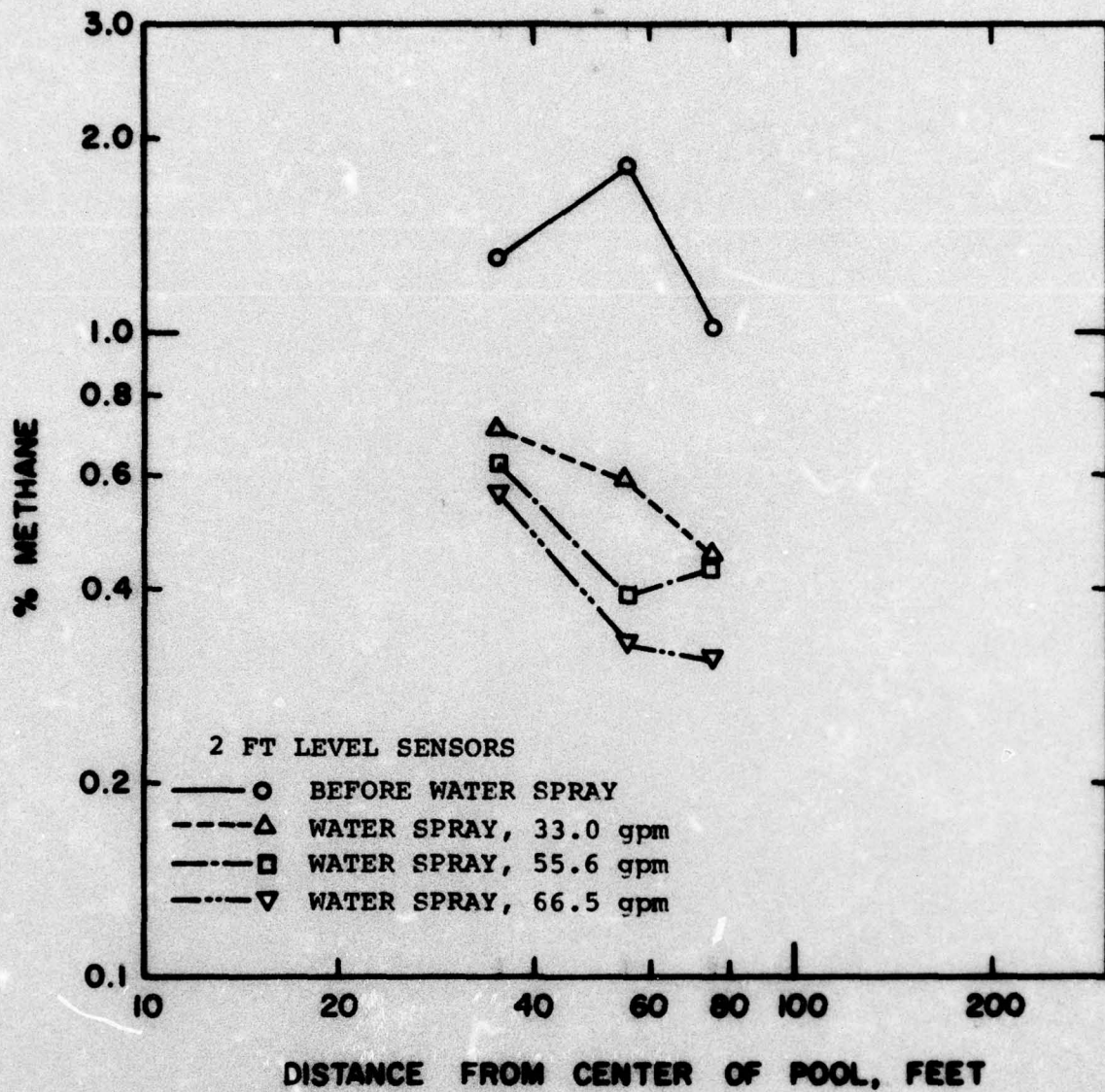

Figure 21. Peak concentrations as a function of distance. Tests 5-8.

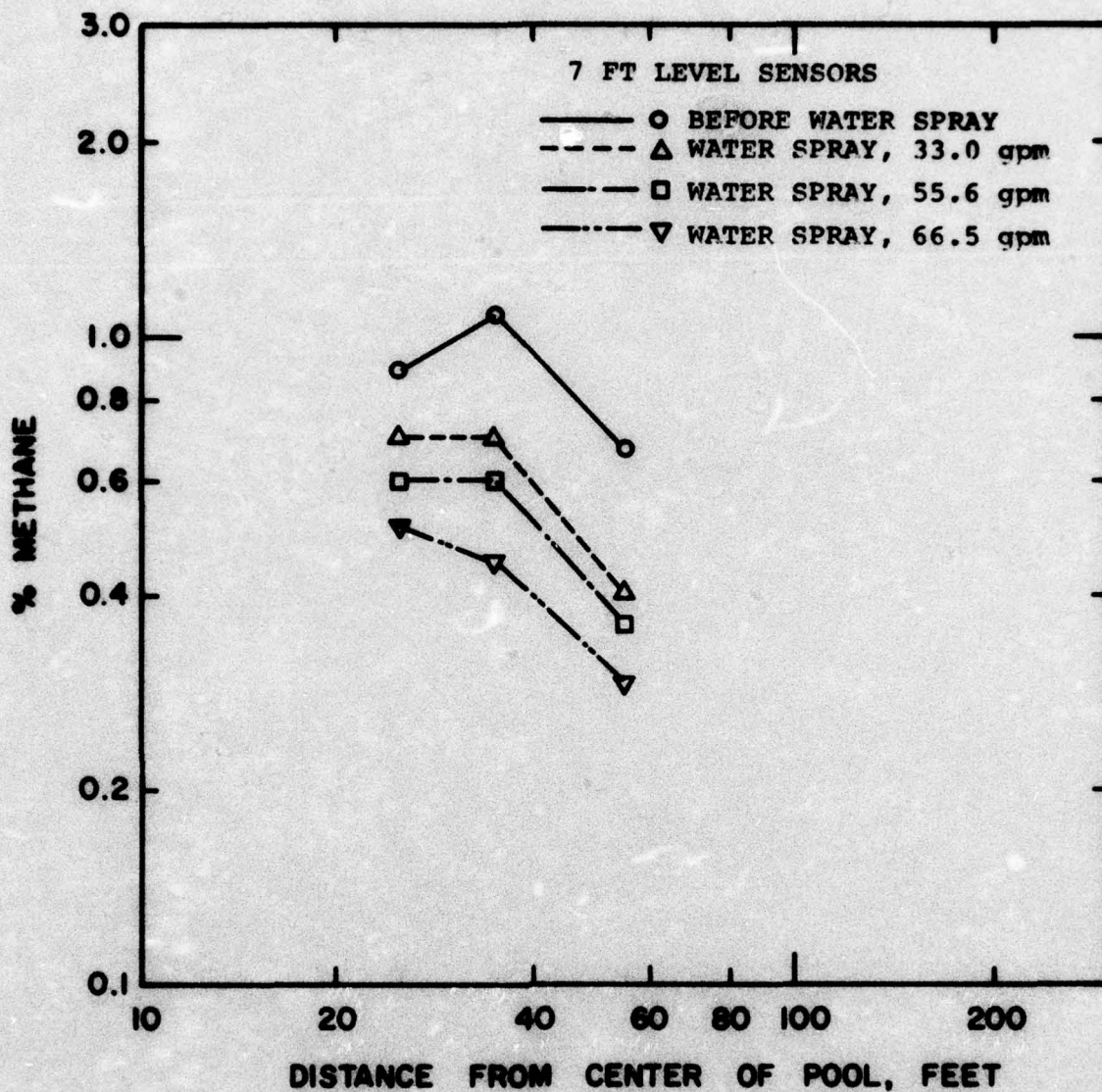

Figure 22. Peak concentrations as a function of distance. Tests 5-8.

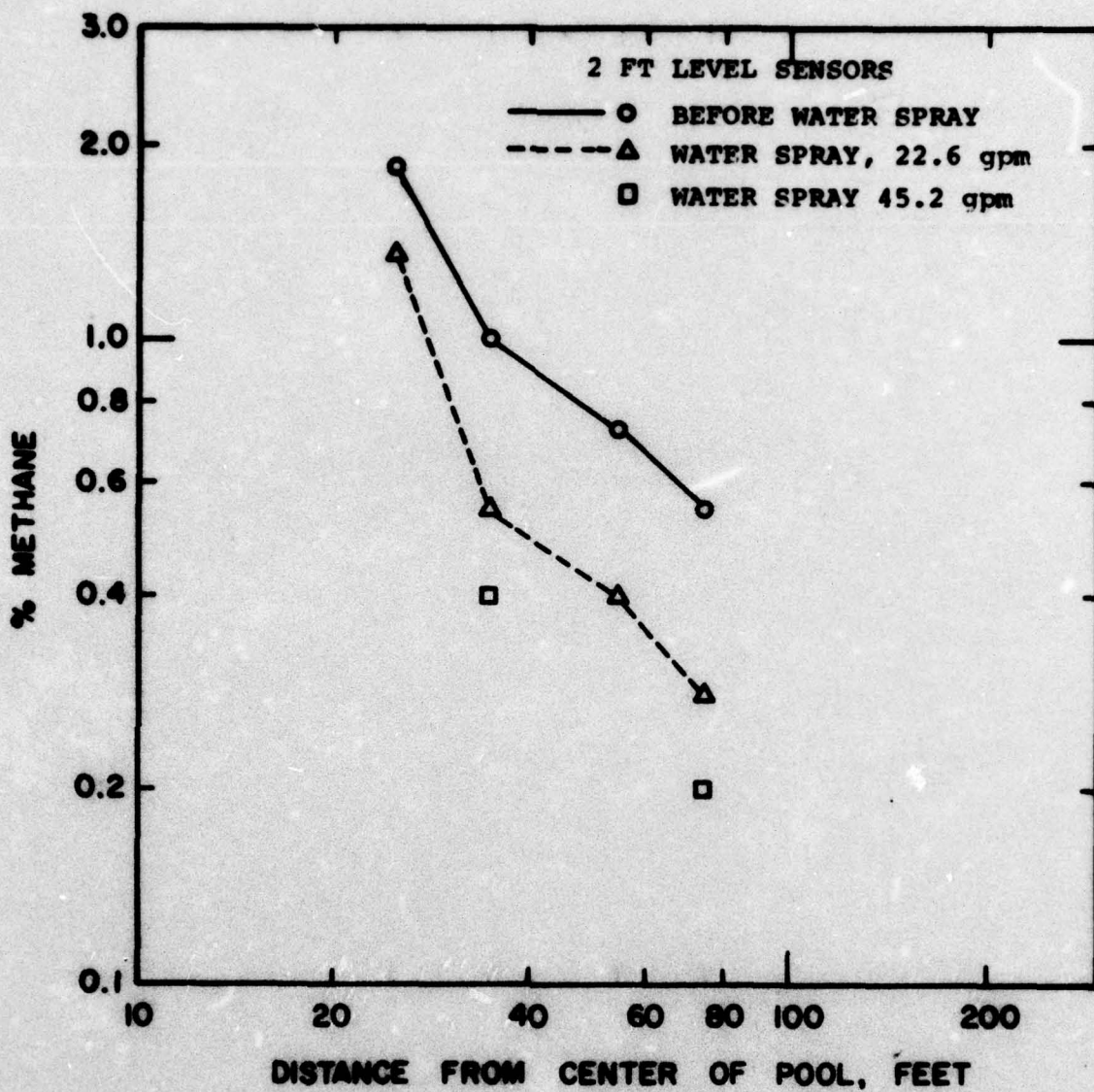

Figure 23. Peak concentrations as a function of distance. Tests 9-12.

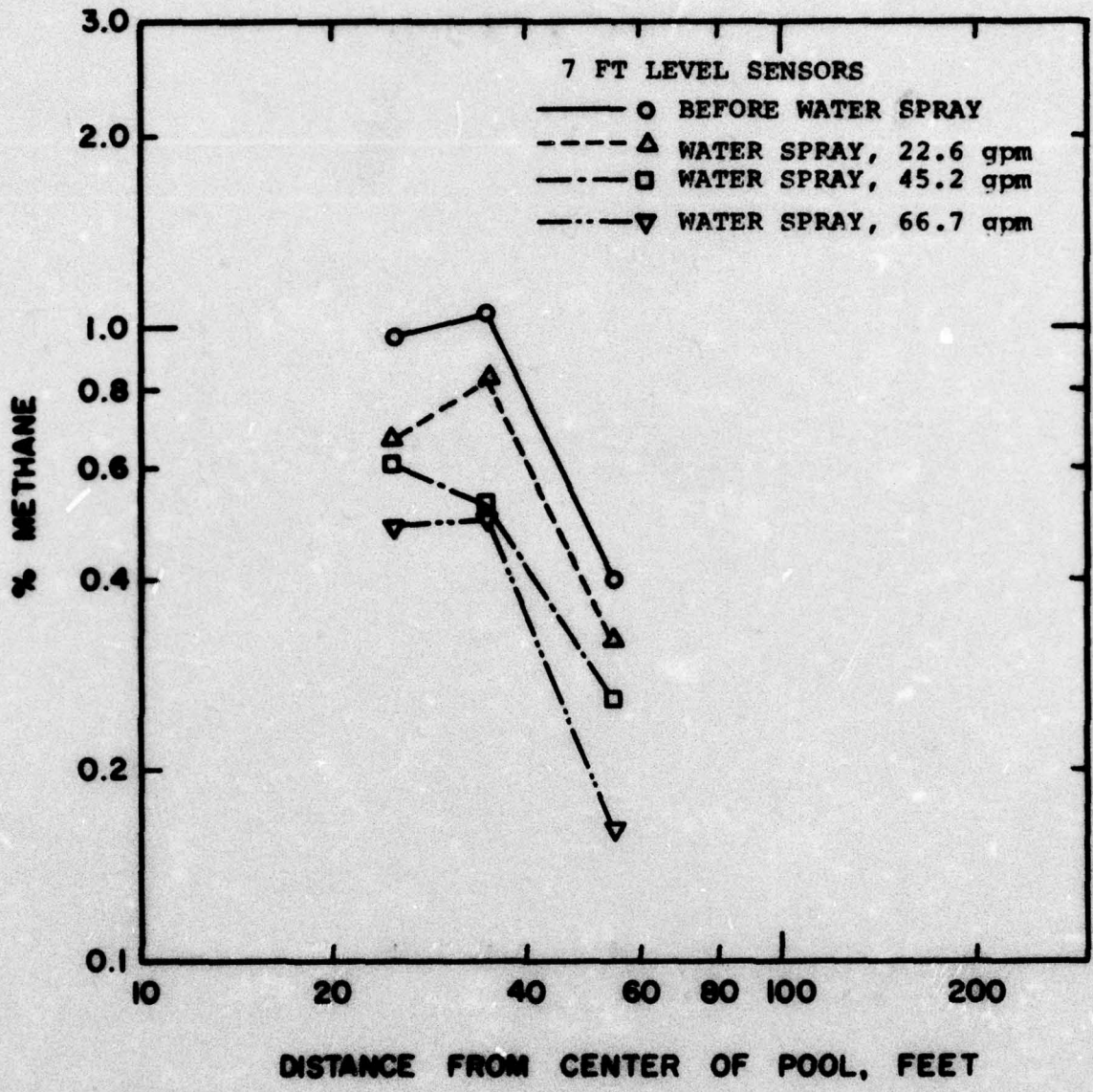

Figure 24. Peak concentrations as a function of distance. Tests 9-12.

MITIGATION OF RADIATION FROM LNG FIRES  
USING WATER SPRAY

Water sprays and/or fogs are commonly used as a technique for reducing the amount of radiant energy from a fire that impinges at some location in the surroundings. Two simple tests were run to illustrate that the application of water to fight the effects of LNG fires must be done properly if a benefit is to result. In the first test, water fog was sprayed directly into the flame immediately above the LNG pool. Most of the water fell into the LNG pool and caused additional vaporization, resulting in a larger flame. Radiation fluxes near the pool were increased by about 75 percent as a consequence of the enhanced vaporization rate.

In the second test, a fan-shaped spray was interposed between the fire and the radiation flux sensors. In these tests, the radiant flux at the sensors was reduced if the water spray was within a few feet of the sensor, but if the sensor was more than about 10 to 15 ft from the spray, little reduction in incident flux was achieved. It is known that water screens reduce radiant fluxes by about 20 percent, provided that the water screen blocks the full solid angle between the flame and the exposed location<sup>4,5</sup>. In the tests, the sensor nearest the water spray had its view of the fire partially blocked by the water spray and the radiation was reduced accordingly. The sensor farther from the spray had much less of its view of the fire obscured, so it showed little change in incident flux.

These two tests showed that water sprays must be properly applied; improperly applied, they may increase the radiant flux or

---

<sup>4</sup>Roytman, M. Y., Principles of Fire Safety Standards (New Delhi, India: Amerind Publ. Co., 1975).

<sup>5</sup>LNG Safety Program, Interim Report on Phase II Work, American Gas Association Project IS-3-1 (July 1, 1974).

reduce it only marginally. A third set of tests was run in the laboratory to attempt measurement of a few of the parameters that affect the design of water spray systems for radiant flux reduction. Figure 25 shows the experimental apparatus. Benzene was continuously supplied to the burner by a constant head siphon system. Benzene was used instead of methane because it could produce higher radiant fluxes. A radiant heat flux sensor (radiometer) was located behind a test panel in such a way that a water spray or film could be established between it and the flame. The flux at the radiometer could be changed in either of two ways: by moving the burner nearer to the radiometer or by injecting oxygen into the flame directly above the liquid fuel surface. In these tests, fluxes up to 25,000 Btu/hr-ft<sup>2</sup> were studied.

The water discharge from the nozzle was directly downward, blocking part of the flame radiation from reaching the radiometer. The portion of the water that was directly between the radiometer and the flame was collected in a trough and measured. In this report, the quantity of water thus collected is expressed in terms of gpm/ft. The gpm refers to the quantity of water collected in the trough and the ft refers to the width of the collecting trough.

There was considerable variation in the reduction in radiant flux, as shown in Figure 26. It was apparent that much of the variation was due to the variability in the water screen between the radiometer and the flame. In tests in which the water screen was essentially all spray or drops, the radiant flux was reduced the least. When the water screen was essentially solid, the greatest flux reduction was achieved. The variability of the data in tests using solid sprays was less than that where drops were formed.

Figure 27 shows the percent reduction in radiant flux for a range of flow rates, with all tests using the same nozzle. The reduction in flux is about 50 to 55 percent at flow rates between about 1.1 gpm/ft and 1.7 gpm/ft, but at higher flow rates the water breaks from a solid sheet and begins to form into a pattern that is partially solid and partially in the form of drops. The flux at the radiometer is then not reduced as much as it was when the water was a continuous sheet.

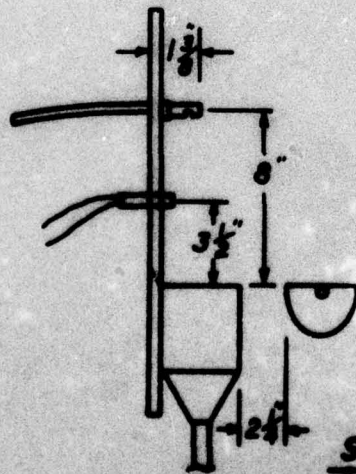
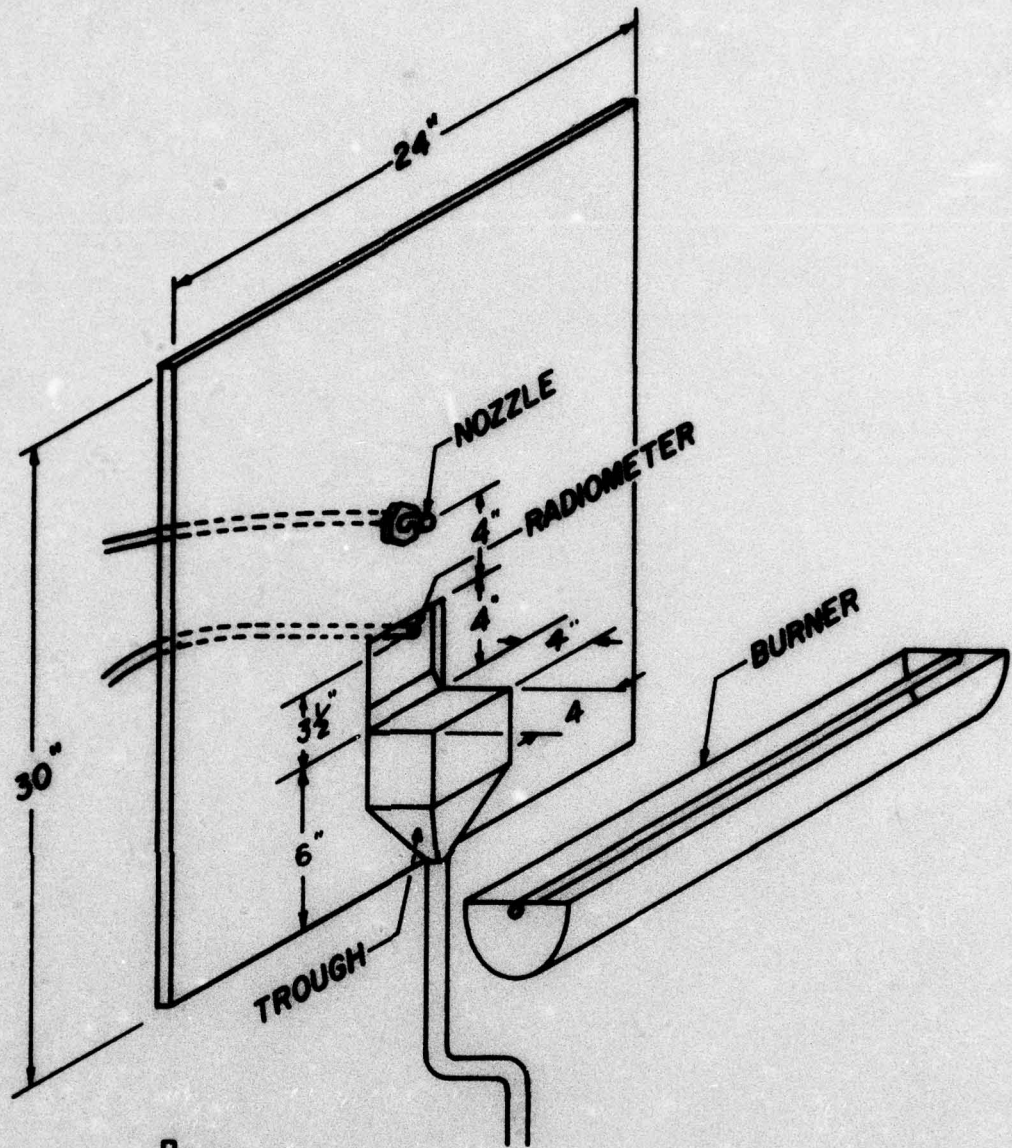

**SIDE**

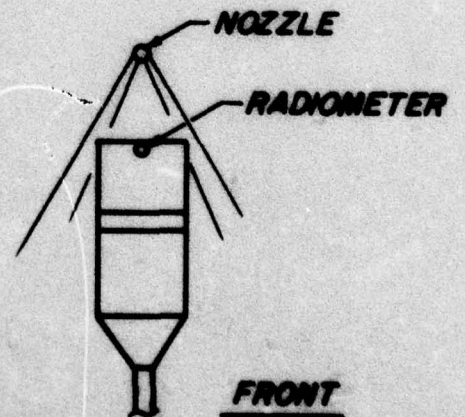

**FRONT**

Figure 25. Water spray test apparatus.

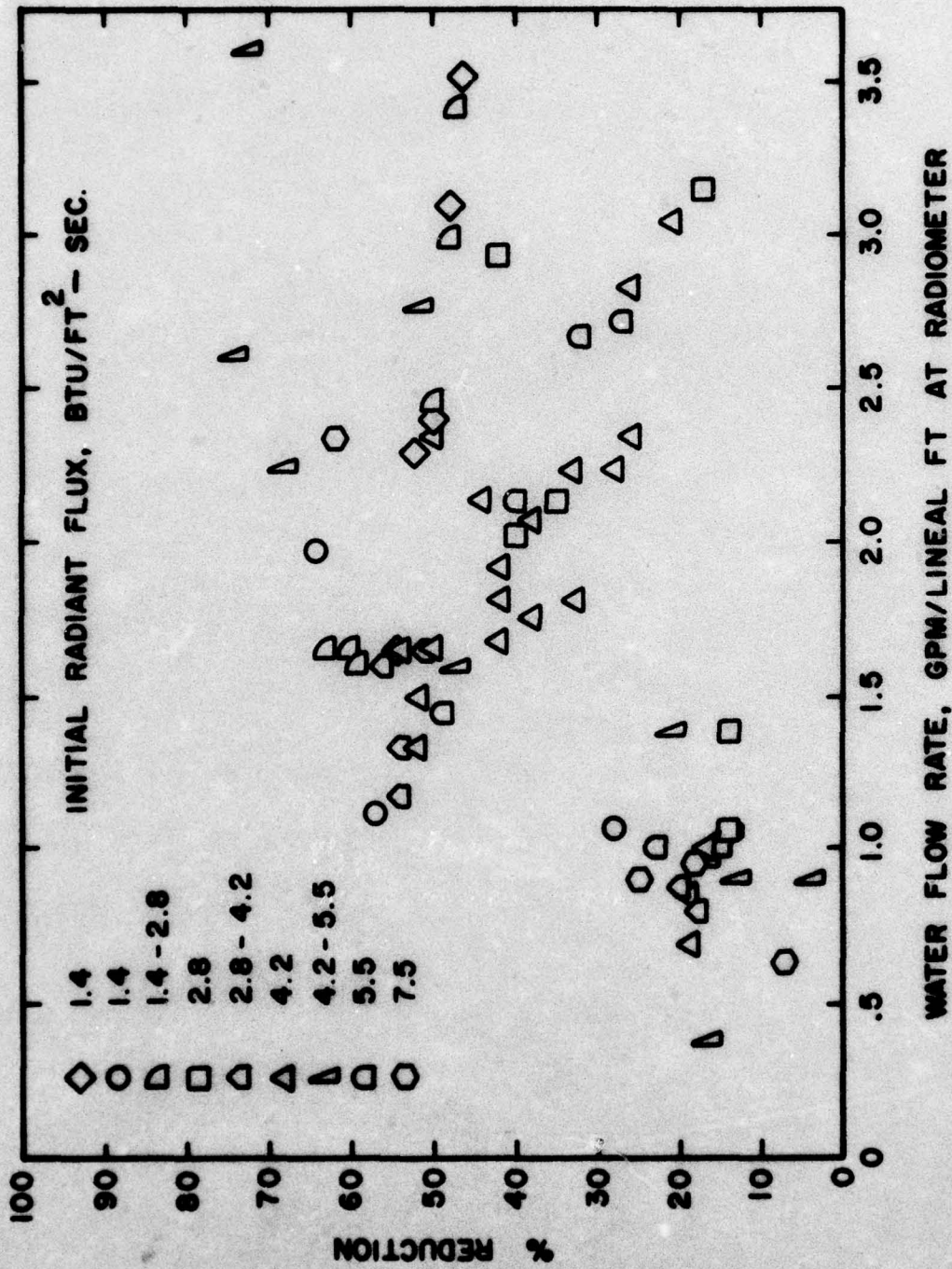

Figure 26. Percent reduction in radiant heat flux as a function of water spray flow rate.

All the tests for which the results are shown in Figure 27 were for an initial flux of 15,000 Btu/hr-ft<sup>2</sup>. Figure 28 shows the reduction in flux as a function of the initial radiant flux at the radiometer. The water flow rate remained constant throughout the tests shown, and was chosen near the maximum flow rate before the continuous sheet broke up into droplets. The reduction in flux is approximately constant, regardless of the initial flux except at fluxes approaching 20,000 Btu/hr-ft<sup>2</sup>. Based on the absorption of the radiant energy by the water film, the flux before and after activation of the water film can be expressed as

$$\frac{I}{I_0} = e^{-\alpha t} \quad (1)$$

where

- I = flux after water film
- I<sub>0</sub> = flux before water film
- α = absorption coefficient
- t = film thickness

The film thickness for the tests shown in Figure 28 was measured and was less than 0.035 in; more accurate measurements were not possible because of changes in film thickness due to turbulence in the water film, but the average thickness is probably about half the maximum. Using the data from Figure 28, I/I<sub>0</sub> is approximately 0.4; if the film thickness is taken as an average of 0.020 in, the absorption coefficient can be calculated. The result is an absorption coefficient of about 46 in<sup>-1</sup> or 18 cm<sup>-1</sup>. This result compares with about 30 cm<sup>-1</sup> for the "virtual" absorption coefficient reported by Nakata and Yamashita<sup>6</sup>. Their result is estimated from tests in which water sprays were used, and the result was not corrected for scattering. If they had accounted for the effect of radiation scattering, their absorption coefficient would have been smaller. The comparison is therefore satisfactory. Heselden and Hinkley<sup>7</sup> also investigated water sprays for radiant heat reduction.

---

<sup>6</sup>Nakata, K., and K. Yamashita, "Attenuation of Radiation Through Water Spray," Fire Research Abstracts and Reviews, 15, 149 (1973).

<sup>7</sup>Heselden, A. J. M., and P. L. Hinkley, "Measurements of the Transmission of Radiation Through Water Sprays," Fire Technology, 1, 130 (1965).

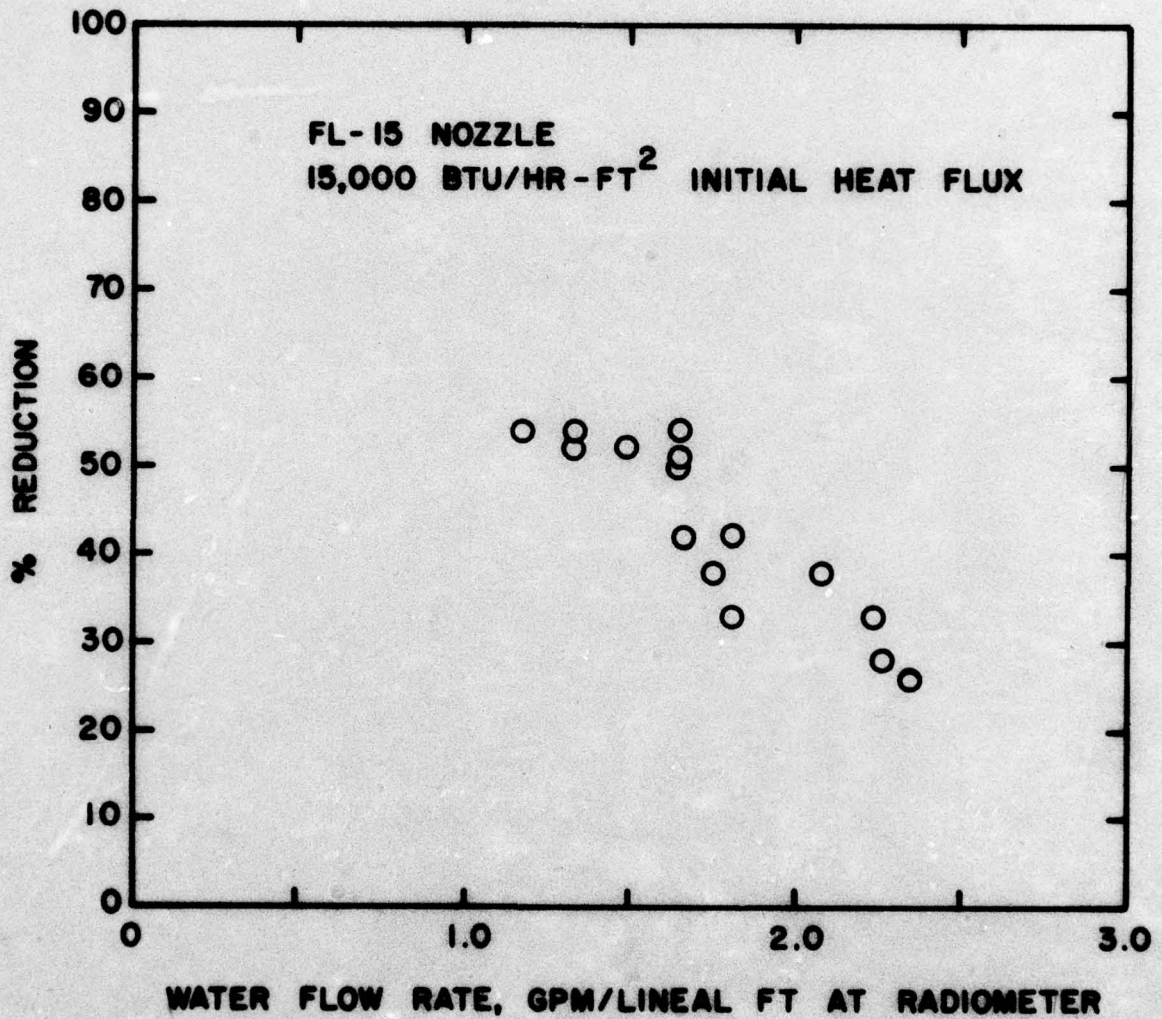

Figure 27. Percent reduction in radiant heat flux as a function of water spray flow rate for one nozzle and constant initial heat flux.

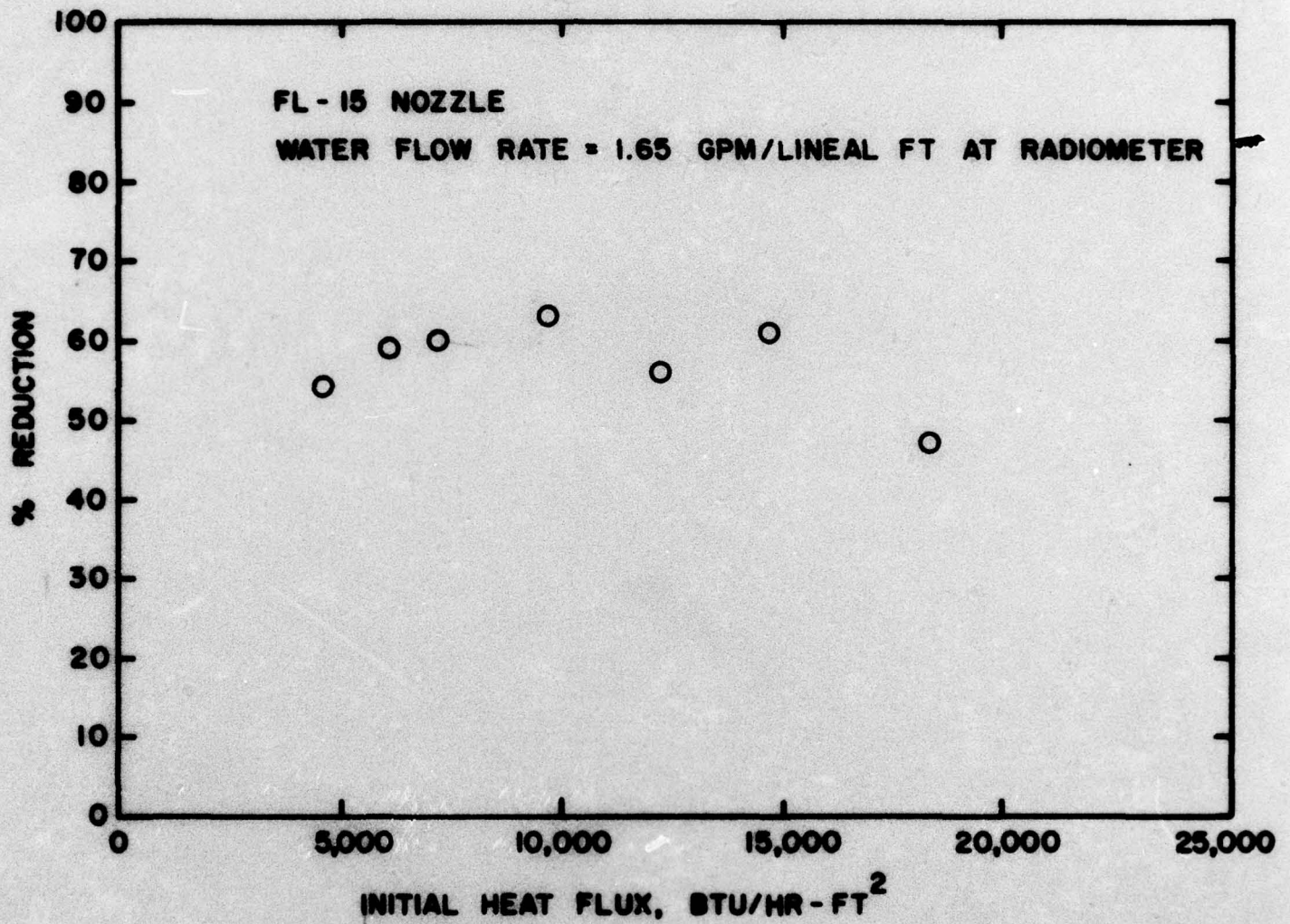

Figure 28. Percent reduction in radiant heat flux as a function of initial heat flux with the water spray screen held constant.

Their results were also not corrected for scattering and they did not attempt to determine an absorption coefficient. Therefore, direct comparison of their results with the results of this study is not appropriate.

The major difficulty encountered in using a water spray or fog is that the water flow rate required for radiation reduction is quite large because the maximum energy sink available in the water is not utilized. In order to maximize the use of the available energy sink, the water must be vaporized, and the most effective way to apply the water is direct contact of the object being protected. Not only is the object then protected from the heat efficiently, but its maximum temperature is limited to a point near the boiling point of water. The overall conclusion is that water is more efficient as a cooling agent if applied directly to the object being protected. "Radiation barrier" water screens, sprays, and fog should be limited to applications where direct cooling is impractical.

## CONCLUSIONS

There was no measurable difference in extinguishment capability of dry chemical powders for the obstructed LNG fires when compared to earlier results for non-obstructed fires. It appears that the rate of dry chemical application required to extinguish LNG fires depends primarily on the total rate of combustion of fuel, provided that the fire is attacked properly and dry chemical is distributed throughout the combustion zone, with special attention to areas that are shadowed by equipment. The correlations of extinguishment data can be used directly for scaling up to larger fire sizes for demonstration tests.

Fires from LNG pools on water present no additional extinguishment problems when compared to those on land except for increases in burning rate that may require higher powder application rates. If the water volume beneath an LNG spill is restricted in size and/or movement, freezing may result, with the result that the fire size may decrease and the fire may be extinguished more easily.

Water sprays can be effective in reducing the concentration of methane downwind of an LNG spill. The mechanism appears to be additional turbulent mixing, with little or no heat transfer or chemical effects. Similar reductions are expected to occur for other gases in cases where no chemical reactions occur or where heat transfer effects are not large. Use of water sprays for reducing concentrations of methane is probably not practical for large spills because of the large quantities of water required; it appears to be a good technique for areas where small spills may occur. The most important design consideration is to provide the maximum turbulence within the spray zone.

Water sprays between fires and "targets" can reduce radiant heating of exposed areas, but the reduction is not large unless the spray is very heavy, requiring large amounts of water. The application of water directly to a surface needing protection is much more effective and economical.

## APPENDIX

### LNG FIRE EXTINGUISHMENT DATA AND ANALYSIS

All of the fire extinguishment data available from these USCG tests and the earlier AGA tests are identified and listed in Table A-1. Note that no monitor nozzle or fixed system data are included and no data for fires on water are included.

The data in Table A-1 were used in a multiple regression analysis to see how well the observed extinguishment times compared with extinguishment times calculated from an equation of the form

$$t = K \left( \frac{A - A_{cr}}{B} \right)^a \quad (A-1)$$

where

- t = extinguishment time (seconds)
- K = a constant
- A = dry chemical application rate (lb/sec-ft<sup>2</sup>)
- A<sub>cr</sub> = critical application rate (lb/sec-ft<sup>2</sup>)
- B = LNG burning rate (in/min)
- a = regression coefficient

By taking the natural logarithm of both sides of Equation A-1, a second equation results which is a straight line when plotted on logarithmic scales.

$$\ln t = \ln K + a \ln \left( \frac{A - A_{cr}}{B} \right) \quad (A-2)$$

The multiple regression analysis used the burning rates and application rates from Table A-1 to determine the values of K and a in Equation A-2 that would result in the straight line that best fit the data. The results for the three dry chemical types tested are given in Table A-2. The table also shows the values for applicable statistical parameters.

TABLE A-1  
RESULTS OF TESTS OF DRY CHEMICAL HANDLINE AND PORTABLE  
EXTINGUISHMENT OF LNG POOL FIRES

LNG Pool Area (ft <sup>2</sup> )	Dry Chemical Type	Dry Chemical Equipment	Dry Chemical Application Rate (lb/sec-ft <sup>2</sup> )	LNG Burning Rate (in/min)	Extinguishment Time (sec)
<u>USCG Tests (1)</u>					
100	SB	1-30# Portable	0.013	0.40	NE *
100	SB	2-30# Portables	0.035	0.40	5.8
100	SB	2-30# Portables	0.050	0.40	4.2
100	SB	2-30# Portables	0.062	0.40	4.2
100	SB	1 Handline	0.034	0.40	5.3
100	SB	1 Handline	0.028	0.40	8.2
<u>AGA Tests (2)</u>					
78	SB	1 Handline	0.104	0.53	3.9
78	SB	1 Handline	0.104	0.53	4.5
78	SB	1 Handline	0.083	0.55	NE *
78	SB	1 Handline	0.080	0.62	NE *
78	SB	1 Handline	0.057	0.28	4.3
78	SB	1 Handline	0.045	0.34	5.7

\* Data points not used in the regression analyses.

TABLE A-1--Cont.  
 RESULTS OF TESTS OF DRY CHEMICAL HANDLINE AND PORTABLE  
 EXTINGUISHMENT OF LNG POOL FIRES

LNG Pool Area (ft <sup>2</sup> )	Dry Chemical Type	Dry Chemical Equipment	Dry Chemical Application Rate (lb/sec-ft <sup>2</sup> )	LNG Burning Rate (in/min)	Extinguishment Time (sec)
78	SB	1 Handline	0.036	0.34	4.9
78	SB	2-10# Portables	0.022	0.34	7.0
78	SB	2 Handlines	0.127	0.69	4.5
78	SB	1 Handline	0.080	0.69	5.8
78	SB	1 Handline	0.080	0.69	7.3
78	SB	1 Handline	0.080	0.26	4.8
20	SB	1-20# Portable	0.071	0.25	4.1
20	SB	1-30# Portable	0.084	0.25	3.0
20	SB	1-30# Portable	0.082	0.33	8.1
20	SB	1-20# Portable	0.071	0.33	4.7
20	SB	2-20# Portables	0.142	0.24	2.0
20	SB	1 Handline	0.255	0.24	1.5
20	SB	2-30# Portables	0.230	1.14	3.8
78	SB	1-30# Portable	0.025	0.50	11.2

\* Data points not used in the regression analyses.

TABLE A-1--Cont.  
RESULTS OF TESTS OF DRY CHEMICAL HANDLINE AND PORTABLE  
EXTINGUISHMENT OF LNG POOL FIRES

LNG Pool Area (ft <sup>2</sup> )	Dry Chemical Type	Dry Chemical Equipment	Dry Chemical Application Rate (lb/sec-ft <sup>2</sup> )	LNG Burning Rate (in/min)	Extinguishment Time (sec)
78	SB	2-20# Portables	0.031	0.34	12.0
20	SB	1-30# Portables	0.115	0.41	3.8
		<u>AGA Tests (3)</u>			
400	SB	2 Handlines	0.060	0.50	4.5
400	SB	1 Handline	0.030	0.50	6.5
400	SB	1 Handline	0.0214	0.50	9.0
400	SB	1 Handline	0.011	0.50	15.7
200	SB	2-30# Portables	0.017	0.50	10.3
1200	SB	2 Handlines	0.0126	0.50	15.0
		<u>USCG Tests (1)</u>			
100	PB	1 Handline	0.031	0.40	10.7
100	PB	1 Handline	0.042	0.40	9.3
100	PB	2-30# Portables	0.033	0.40	5.8
100	PB	1-30# Portable	0.014	0.40	NE *

\* Data points not used in the regression analyses.

TABLE A-1--Cont.

RESULTS OF TESTS OF DRY CHEMICAL HANDLINE AND PORTABLE  
EXTINGUISHMENT OF LNG POOL FIRES

LNG Pool Area (ft <sup>2</sup> )	Dry Chemical Type	Dry Chemical Equipment	Dry Chemical Application Rate (lb/sec-ft <sup>2</sup> )	LNG Burning Rate (in/min)	Extinguishment Time (sec)
		<u>AGA Tests (2)</u>			
20	PB	1-10# Portable	0.036	0.25	NE *
20	PB	1-10# Portable	0.036	1.10	NE *
20	PB	1-30# Portable	0.082	1.14	5.8
78	PB	1 Handline	0.080	.40	6.6
78	PB	2-30# Portables	0.041	1.08	6.4
78	PB	1-30# Portable	0.021	0.41	8.2
78	PB	1-30# Portable	0.018	0.74	16.6
78	PB	1-30# Portable	0.025	0.33	6.9
78	PB	1-30# Portable	0.015	0.52	NE *
78	PB	1 Handline	0.080	0.52	NE *
78	PB	1 Handline	0.048	0.451	5.9
		<u>AGA Tests (3)</u>			
400	PB	1 Handline	0.020	0.50	8.0
1000	PB	2 Handlines	0.0069	0.50	NE *

\* Data points not used in the regression analyses.

TABLE A-1--Cont.  
 RESULTS OF TESTS OF DRY CHEMICAL HANDLINE AND PORTABLE  
 EXTINGUISHMENT OF LNG POOL FIRES

LNG Pool Area (ft <sup>2</sup> )	Dry Chemical Type	Dry Chemical Equipment	Dry Chemical Application Rate (lb/sec-ft <sup>2</sup> )	LNG Burning Rate (in/min)	Extinguishment Time (sec)
400	PB	1 Handline	0.0086	0.50	16.0
360	PB	2-30# Portables	0.0078	0.50	13.2
1200	PB	2 Handlines	0.0133	0.50	12.7
325	PB	1 Handline	0.0222	0.50	5.5
1200	PB	2 Handlines	0.0137	0.50	12.8
200	PB	1-30# Portable	0.017	0.50	NE *
<u>USCG Tests (1)</u>					
100	U-PB	1-30# Portable	0.020	0.40	3.9
100	U-PB	1-30# Portable	0.015	0.40	5.7
100	U-PB	2-30# Portables	0.044	0.40	2.0
100	U-PB	1 Handline	0.028	0.40	3.5
100	U-PB	1 Handline	0.026	0.40	2.8
<u>AGA Tests (2)</u>					
20	U-PB	1-30# Portable	0.066	0.25	2.1

\* Data points not used in the regression analyses.

TABLE A-1--Cont.  
RESULTS OF TESTS OF DRY CHEMICAL HANDLINE AND PORTABLE  
EXTINGUISHMENT OF LNG POOL FIRES

LNG Pool Area (ft <sup>2</sup> )	Dry Chemical Type	Dry Chemical Equipment	Dry Chemical Application Rate (lb/sec-ft <sup>2</sup> )	LNG Burning Rate (in./min)	Extinguishment Time (sec)
20	U-PB	1-30# Portable	0.066	0.33	5.9
20	U-PB	1-30# Portable	0.051	1.14	NE *
78	U-PB	2-30# Portables	0.032	0.82	8.6
78	U-PB	1-30# Portable	0.017	0.45	4.9
78	U-PB	1-30# Portable	0.013	0.64	NE *
78	U-PB	1 Handline	0.057	0.40	2.7
78	U-PB	1 Handline	0.064	0.40	2.7
78	U-PB	1 Handline	0.067	0.40	2.8
78	U-PB	1 Handline	0.070	0.40	3.0
<u>AGA Tests (3)</u>					
325	U-PB	2 Handlines	0.031	0.50	5.0
325	U-PB	1 Handline	0.0155	0.50	7.0
1200	U-PB	3 Handlines	0.0124	0.50	7.0
325	U-PB	1-30# Portable	0.00385	0.50	11.5
1200	U-PB	1 Handline	0.00275	0.50	25.0

\* Data points not used in the regression analyses.

REFERENCES FOR TABLE A-1

1. Results of this series of tests for U.S. Coast Guard.
2. University Engineers, Inc., "An Experimental Study on the Mitigation of Flammable Vapor Dispersion and Fire Hazards Immediately Following LNG Spills on Land," Report to American Gas Association, AGA Project IS-100-1, February, 1974.
3. American Gas Association, "LNG Safety Program, Phase II: Consequences of LNG Spills on Land," Final Report on AGA Project IS-3-1, November 15, 1973.

