

ADA033592

AFWL-TR-73-256, Vol. I

12

AFWL-TR-73-256
Vol. I

AG.



NONELECTRICAL LANGUAGES SIMULATION MODULE (NELSIM)

Volume I

TRW Systems Group
Nuclear Survivability Dept. ?
Redondo Beach, CA 90278

II
A033606

DDC
RECEIVED
DEC 20 1976
C

September 1976

Final Report

Approved for public release; distribution unlimited.

This research was sponsored by the Defense Nuclear Agency under Subtask Z99QAXTC022, Work Unit 52, Work Unit Title: Interface Program for Circuit Analysis.

Prepared for
Director
DEFENSE NUCLEAR AGENCY
Washington, DC 20305

AIR FORCE WEAPONS LABORATORY
Air Force Systems Command
Kirtland Air Force Base, NM 87117

7405 15

This final report was prepared by TRW Systems Group, Nuclear Survivability Department, Redondo Beach, California, under Contract F29601-73-C-0024, Job Order WDNE1302, with the Air Force Weapons Laboratory, Kirtland Air Force Base, New Mexico. Mr. White (ELP) was the Laboratory Project Officer-in-Charge.

When US Government drawings, specifications, or other data are used for any purpose other than a definitely related Government procurement operation, the Government thereby incurs no responsibility nor any obligation whatsoever, and the fact that the Government may have formulated, furnished, or in any way supplied the said drawings, specifications, or other data is not to be regarded by implication or otherwise as in any manner licensing the holder or any other person or corporation or conveying any rights or permission to manufacture, use or sell any patented invention that may in any way be related thereto.

This report has been reviewed by the Information Office (OI) and is releasable to the National Technical Information Service (NTIS). At NTIS, it will be available to the general public, including foreign nations.

This technical report has been reviewed and is approved for publication.

A. Brent White

A. BRENT WHITE
Project Officer

FOR THE COMMANDER

Larry W. Wood

LARRY W. WOOD
Lt Colonel, USAF
Chief, Phenomenology/Technology
Branch

James L. Griggs

JAMES L. GRIGGS
Colonel, USAF
Chief, Electronics Division

ACCESSION FOR	NTIS	DTIC	UNCLASSIFIED	INVESTIGATION	BY	LISTED FOR AVAILABILITY CODES	DATE	APPROVED BY / OR S. GILL
	<input type="checkbox"/>	<input type="checkbox"/>	<input type="checkbox"/>					

A

DO NOT RETURN THIS COPY. RETAIN OR DESTROY.



UNCLASSIFIED

SECURITY CLASSIFICATION OF THIS PAGE (When Data Entered)

REPORT DOCUMENTATION PAGE		READ INSTRUCTIONS BEFORE COMPLETING FORM
1. REPORT NUMBER AFWL-TR-73-256-Vol 1-1 ✓	2. GOVT ACCESSION NO.	3. RECIPIENT'S CATALOG NUMBER 9
4. TITLE (and Subtitle) NONELECTRICAL LANGUAGES SIMULATION MODULE (NELSIM). Volume I.		5. TYPE OF REPORT & PERIOD COVERED Final Report.
7. AUTHOR(s) M. Epstein J.R. Pistacchi	8. CONTRACT OR GRANT NUMBER(s) F29601-73-C-0024 NEW	
PERFORMING ORGANIZATION NAME AND ADDRESS TRW Systems Group 1 Space Park Redondo Beach, CA 90278 Nuclear Survivability Dept	10. PROGRAM ELEMENT, PROJECT, TASK AREA & WORK UNIT NUMBERS 62704H WDNET302	
11. CONTROLLING OFFICE NAME AND ADDRESS Director Defense Nuclear Agency Washington, D.C. 20305	12. REPORT DATE Sept 1976	
14. MONITORING AGENCY NAME & ADDRESS (if different from Controlling Office) Air Force Weapons Laboratory (ELP) Kirtland Air Force Base, NM 87117	13. NUMBER OF PAGES 70	15. SECURITY CLASS. (of this report) UNCLASSIFIED
16. DISTRIBUTION STATEMENT (of this Report) Approved for public release; distribution unlimited.		15a. DECLASSIFICATION/DOWNGRADING SCHEDULE 12 65p.
17. DISTRIBUTION STATEMENT (of the abstract entered in Block 20, if different from Report)		
18. SUPPLEMENTARY NOTES This research was sponsored by the Defense Nuclear Agency under Subtask Z990AXTC022, Work Unit 52, Work Unit Title: Interface Program for Circuit Analysis.		
19. KEY WORDS (Continue on reverse side if necessary and identify by block number) Analysis Computer Aided Analysis CADA Network Simulation Non-electrical Languages for Simulation		
20. ABSTRACT (Continue on reverse side if necessary and identify by block number) NELSIM is a FORTRAN IV computer program written for the CDC 6000 series computers. NELSIM generates electrical analogs from mechanical, thermal, electro mechanical and electro optical system input descriptions. The electrical analogs generated are in a format acceptable to the SCEPTRE (System for Circuit Evaluation and Prediction of Transient Radiation Effects) program. The NELSIM output can then be executed on the SCEPTRE program to determine the system transient response. This report documents the theory and formulation utilized in the generation of NELSIM. The structure of the program and its subroutines are discussed. Also		

DD FORM 1473 1 JAN 73

EDITION OF 1 NOV 65 IS OBSOLETE

UNCLASSIFIED

SECURITY CLASSIFICATION OF THIS PAGE (When Data Entered)

409971 LB

UNCLASSIFIED

SECURITY CLASSIFICATION OF THIS PAGE(When Data Entered)

(b1k 20)

included is a sample problem section illustrating the input and output of the program and subsequent transient response obtained.



UNCLASSIFIED

SECURITY CLASSIFICATION OF THIS PAGE(When Data Entered)

TABLE OF CONTENTS

SECTION	Page
I. INTRODUCTION	1
II. CONVERSION TO ELECTRIC ANALOGS	5
Mechanical/Electrical Analogs	6
Thermal/Electrical Analogs	12
Electro-Mechanical/Electrical Analogs.	20
Electro-Optical/Electrical Analogs	32
Units and Scaling.	35
III. DIFFERENTIAL EQUATIONS	41
IV. TRANSFER FUNCTIONS	45
V. PROGRAM CONFIGURATION	48

ILLUSTRATIONS

		Page
FIGURE 1.	Program Modular Configuration	3
FIGURE 2.	Input/Output of NELSIM.	4
FIGURE 3.	System Elements	8
FIGURE 4.	Mechanical System Example	10
FIGURE 5.	Mechanical Network Equivalent	10
FIGURE 6.	Electrical Analogy of Mechanical Example.	11
FIGURE 7.	Thermal System Example	17
FIGURE 8.	Thermal Example Analog.	19
FIGURE 9.	An Electro Mechanical System.	20
FIGURE 10.	Galvanometer Schematic Representation	22
FIGURE 11.	Lumped Element Galvanometer Equivalent.	22
FIGURE 12.	Galvanometer Electrical Analog.	23
FIGURE 13.	Block Diagram of Rate Gyro	24
FIGURE 14.	NELSIM Equivalent Rate Gyro	25
FIGURE 15.	Accelerometer Model	28
FIGURE 16.	NELSIM Accelerometer Equivalent	29
FIGURE 17.	Breakdown of Motor Transfer Function Block.	30
FIGURE 18.	Equivalent Circuit of A Photodiode.	32
FIGURE 19.	Wavelength Dependence of Quantum Efficiency and Responsitivity for Several High Speed Photodiodes . . .	33
FIGURE 20.	Unity Feedback System Example	47
FIGURE 21.	Main Function of Non-Electrical Languages Simulation Module	48
FIGURE 22.	NELSIM Major Functions.	49
FIGURE 23.	NELSIM Input Processor.	52
FIGURE 24.	Function Subheading Processor	53
FIGURE 25.	Translator Main Routines.	54
FIGURE 26.	DET Functional Flow	56
FIGURE 27.	Transfer Function Translator Functional Flow.	57
FIGURE 28.	Output Processor Routines	58

LIST OF TABLES

	Page
TABLE I. Analogous Quantities Between Mechanical, Thermal . . . and Electrical Systems	5
TABLE II. Mechanical Units	8
TABLE III. Mechanical/Electrical Analogs (Translational).	12
TABLE IV. Mechanical/Electrical Analogs (Rotational)	12
TABLE V. Thermal Units	16
TABLE VI. Thermal/Electrical Analogs.	19
TABLE VII. Performance Characteristics of Photodiodes.	34
TABLE VIII. System Analogies	38
TABLE IX. Standard System Units	38
TABLE X. Major NELSIM Routines and Functions	50

SECTION I
INTRODUCTION

The NonElectrical Languages Simulation Module (NELSIM) for the Air Force Weapons Laboratory Systems Analysis Program provides the capability for large-scale nonlinear system analysis of systems composed of mechanical, thermal, electromechanical, and electro-optical components in addition to electrical and electronic components. This module permits engineers not familiar with disciplines generally associated with circuit simulation programs to solve system problems without manually deriving electrical analogs and differential equations for use with the circuit analysis programs.

A number of computer-aided circuit analysis programs have been developed to automatically calculate the transient response of nonlinear circuits. To use these programs, it is generally necessary to describe the circuit topology to the program in terms of the electrical network parameters resistance, inductance, capacitance, voltage and current. The programs automatically generate a set of algebraic and differential equations from the network topology; the algebraic equations are solved and the differential equations are numerically integrated to determine the transient response.

Current and future weapons systems have rigid specifications for operation in benign and hostile nuclear weapon environments. It has become increasingly important to have efficient computer-aided system analysis capabilities in addition to the existing circuit analysis capabilities. The system problem can be solved using numerical methods similar to those used in circuit analysis programs because systems, like circuits, can be defined in terms of algebraic and differential

equations. Therefore, it is possible to adapt circuit analysis programs to the solution of system level problems.

While the system to be analyzed can be mathematically described in a manner consistent with available circuit analysis programs, the systems may contain components other than electrical or electronic components, and to predict the transient system response, it is necessary to include the non-electrical components in the system analysis. In adopting the circuit analysis programs to system level problems, an automatic language processor was developed to convert descriptions of non-electronic system components to a form compatible with the applicable analysis programs being used. This procedure permits the description of the entire system to the program in the language particular to the different system components. The language processor automatically develops the appropriate algebraic and differential equations to determine the transient response; and the system analyst is relieved of developing electrical analogs or writing differential equations compatible with the system simulation code of interest.

The program translates the given system inputs into electrical analogues and equations compatible with the SCEPTRE program. To give the program flexibility to interface with the AFWL systems analysis program and provide the capability to interface with transient analysis programs other than SCEPTRE, the program is divided into three main parts — an input processor, a translator, and an output processor as shown in Figure 1.

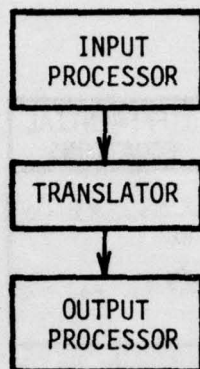

Figure 1. Program Modular Configuration

The input processor interprets and stores all input information. This input can be in three forms, illustrated in Figure 2. The translator generates the electrical analogs based upon the information stored within the program. The output processor then generates analogous in a format acceptable to SCEPTRE. To alter the program to be compatible with other programs simply involves alteration of the output module.

The remainder of this report documents the theory and formulation utilized in the generation of NELSIM. Sections II through IV document those portions of the program dealing with analog system functional elements, differential equations and transfer functions, respectively. Section V documents the program configuration and functional flow. The versatility of the program is illustrated through the sample problem package contained in Section VI.

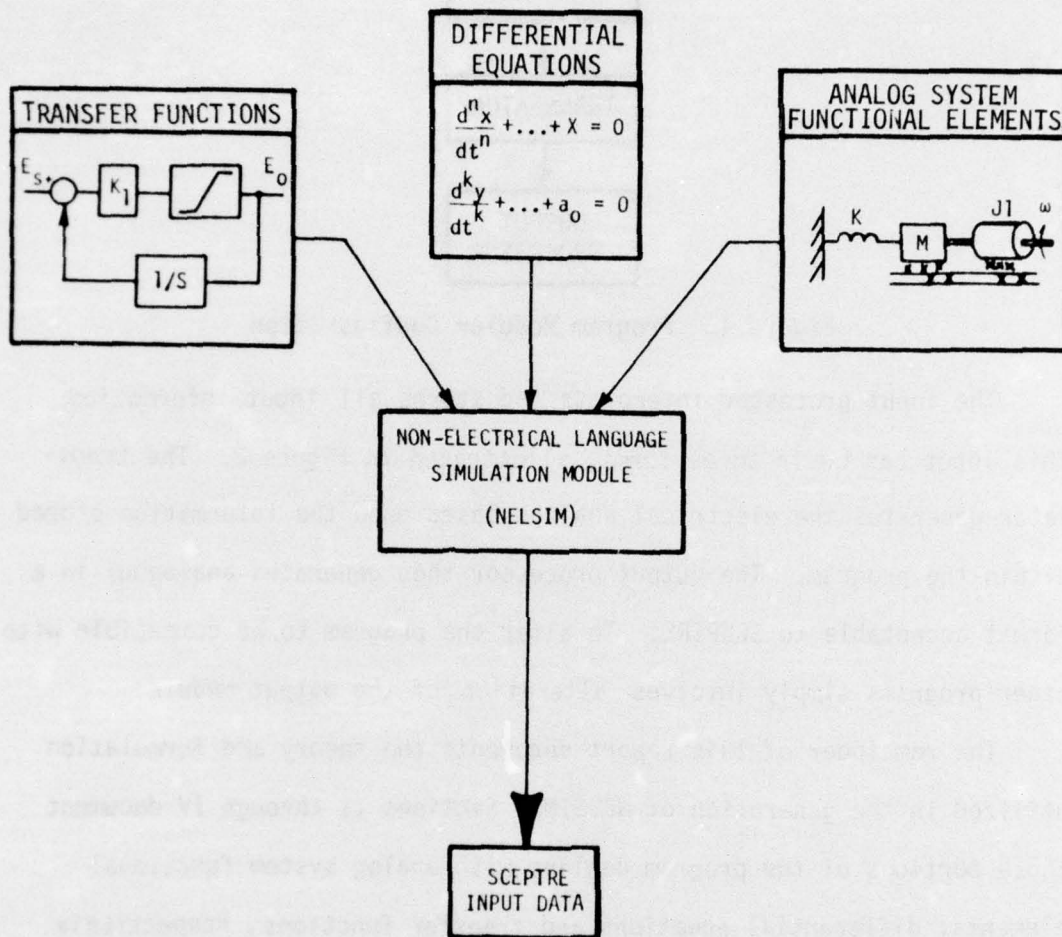

Figure 2. Input/Output of NELSIM

SECTION II

CONVERSION TO ELECTRICAL ANALOGS

Systems of equations from one scientific discipline that have the same form as those equations of another discipline are called analogs. The quantities which occupy corresponding positions in the two equations are called analogous quantities. This section is concerned with establishing analogs from the non-electrical disciplines to the electrical discipline using NELSIM. Electrical analogs allow solution of non-electrical problems using computer programs such as SCEPTRE, NET-2 or CIRCUS II.

The analogs from mechanical and thermal systems to electrical systems are summarized in Table I.

Table I. Analogous Quantities Between Mechanical, Thermal and Electrical Systems

GENERALIZED QUANTITIES	ELECTRICAL QUANTITIES	MECHANICAL TRANSLATIONAL QUANTITIES	MECHANICAL ROTATIONAL QUANTITIES	THERMAL QUANTITIES
Flow Variable $q(t)$	Current $i(t)$	Force $f(t)$	Torque $\tau(t)$	Heat Flow Rate $q(t)$
Potential Variable $p(t)$	Voltage $e(t)$	Velocity $v(t)$	Angular Velocity $\omega_r(t)$	Temperature $\theta(t)$
POWER	$e(t)i(t)$	$f(t)v(t)$	$\tau(t)\omega_r(t)$	$q(t)$
$q(t) = Gp(t)$	$i(t) = \frac{1}{R}e(t)$	$f(t) = Bv(t)$	$\tau(t) = B_r\omega_r(t)$	$q(t) = \frac{1}{R_T}\theta(t)$
$q(t) = C \frac{dp}{dt}$	$i(t) = C \frac{de}{dt}$	$f(t) = M \frac{dv}{dt}$	$\tau(t) = J \frac{d\omega_r}{dt}$	$q(t) = C_T \frac{d\theta}{dt}$
$q(t) = K \int p dt$	$i(t) = \frac{1}{L} \int e dt$	$f(t) = K \int v dt$	$\tau(t) = K_r \int \omega_r dt$	

The disciplines allowed as input into the NELSIM program are listed below and discussed individually in the following paragraphs.

1. Mechanical
2. Thermal
3. Electro-mechanical
4. Electro-optical

a. Mechanical/Electrical Analogs

Mechanical systems can be described by various combinations of translational and torsional elements and forces. The analysis of dynamic mechanical systems primarily consists of determining the time dependence of resulting translational or torsional displacements, velocities, and accelerations of the various system elements under the influence of an externally applied disturbing force or torque. The basic description of a mechanical system includes the values of the system lumped elements and their physical interconnection with each other. This is in addition to specifying the magnitude and time behavior of the externally applied disturbing force or torque. The dissipating or damping parameter is the dashpot or friction device. For linear friction or damping models the retarding force is proportional to the velocity and in a direction opposite to the velocity vector. Friction of this linear nature is known as viscous friction, or viscous damping. Its existence is well established experimentally for moderate velocities. For large velocities, the resistance becomes nonlinear and may be more nearly proportional to the square or even the cube of the velocity.

The mass, moment of inertia, spring and elastic shaft act as energy reservoirs of the system. The spring and elastic shaft are reservoirs of

potential energy and the mass and moment of inertia are reservoirs of kinetic energy. The energy storing characteristic of the spring is expressed in terms of the force per unit translational displacement. Similarly, the elastic shaft has units of torque per unit angular displacement. A nonlinear spring would exist for the condition when the spring is stretched beyond its elastic limits and the plastic deformation of the material would no longer produce a spring displacement proportional to the applied force.

The energy storing characteristic of the mass is related in terms of the force per unit acceleration or weight per unit gravitational acceleration. Similarly, the moment of inertia has units of torque per unit angular acceleration. An example of non-constant mass situation which would result in nonlinear differential equations arises in relativistic mechanics where the effective mass of a particle increases as the velocity of the particle approaches the speed of light. An infinite force is required to propel a particle with even the smallest rest mass at the speed of light.

For a mechanical translational system, the dynamic analysis of the system is based upon Newton's law:

$$\text{Mass} \times \text{Acceleration} = \text{Force}$$

The analysis of a torsional system is based upon Newton's law in the form:

$$\text{Moment of Inertia} \times \text{Angular Acceleration} = \text{Torque}$$

The elements involved in translational and rotational systems are illustrated in Figure 3 along with their respective relationships. Table II shows the units involved for each type of system. A set of equations describing the dynamic behavior of a mechanical system is obtained by

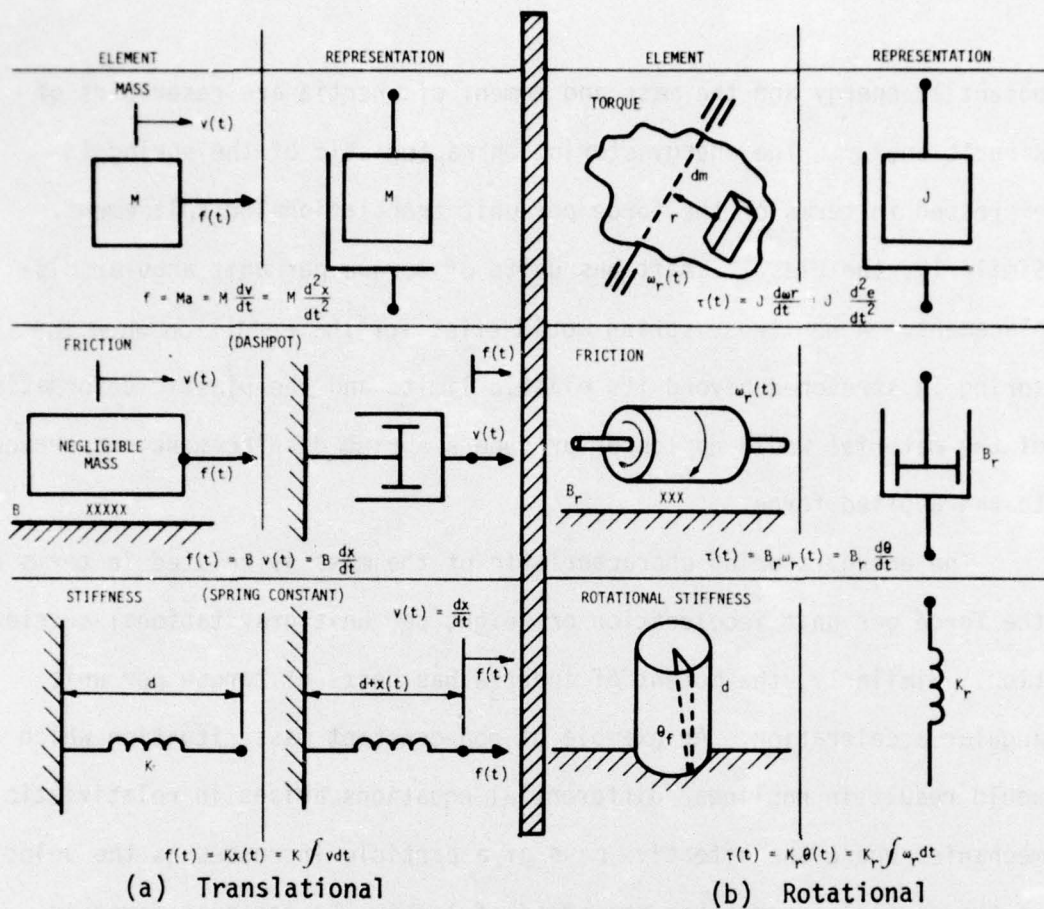

Figure 3. System Elements

Table II. Mechanical Units

TRANSLATIONAL	$f(t)$	$v(t)$	M	B	K
mks units	Newton	meter/sec	Kilogram (kg)	Newton-sec/meter	Newton/meter
English Units	pound (lb)	ft/sec	slug	lb-sec/ft	lb/ft
ROTATIONAL	$\tau(t)$	$\omega_r(t)$	J	B_r	K_r
mks units	Newton-meter	radians/sec	Kilogram-meter ²	Newton-meter sec/radian	Newton-meter/radian
English Units	lb-ft	radians/sec	slug-ft ²	lb-ft-sec/radian	lb-ft/radian

setting the sum of the reacting forces (or torques) equal to the disturbing or applied force (or torque). This is equivalent to setting all forces or torques at a junction equal to 0, i.e.,

$$f(t) = 0 \text{ at a junction}$$

$$T(t) = 0 \text{ at a junction}$$

The example shown in Figure 4 illustrates the principles discussed for a translational system. This example represents a translational mechanical system where it is desired to solve for the velocities $v_2(t)$ and $v_3(t)$ of the system when an external force is applied resulting in velocity $v_1(t)$. Figure 5 represents a mechanical network equivalent of Figure 4. Equations (1) and (2) result when the velocity measurements are made at masses M_2 and M_3 .

$$K_1 \int (v_2 - v_1) dt + M_2 \frac{dv_2}{dt} + B(v_2 - v_3) + K_2 \int (v_2 - v_3) dt = 0 \quad (1)$$

$$B(v_3 - v_2) + K_2 \int (v_3 - v_2) dt + M_3 \frac{dv_3}{dt} + K_3 \int v_3 dt = 0 \quad (2)$$

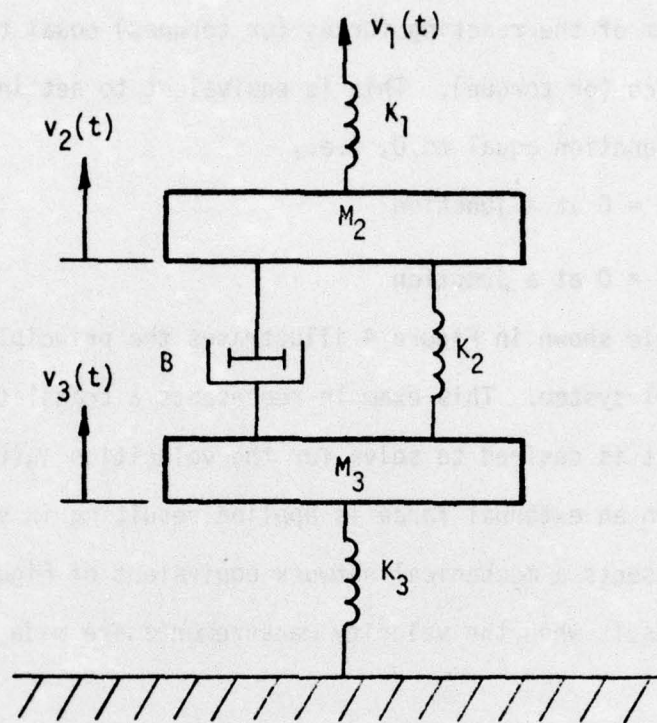

Figure 4. Mechanical System Example

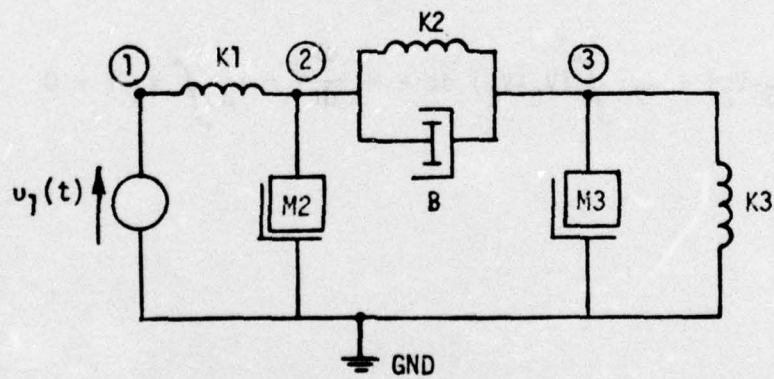

Figure 5. Mechanical Network Equivalent

Differentiating each side with respect to t results in the set of second order differential equations shown by Equations (3) and (4).

$$K_1 (V_2 - V_1) + M_2 \dot{V}_2 + B (V_2 - V_3) + K_2 (V_2 - V_3) = 0 \quad (3)$$

$$B (V_3 - V_2) + K_2 (V_3 - V_2) + M_3 \dot{V}_3 + K_3 V_3 = 0 \quad (4)$$

Figure 6 shows an electrical network. Equations (5) and (6) are the differential equations generated to obtain the solution for voltages throughout the network.

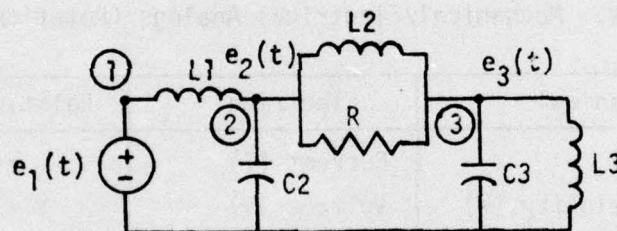

Figure 6. Electrical Analogy of Mechanical Example

$$\frac{1}{L1} (e_2 - e_1) + C_2 \dot{e}_2 + \frac{1}{R} (e_2 - e_3) + \frac{1}{L2} (e_2 - e_3) = 0 \quad (5)$$

$$\frac{1}{R} (e_3 - e_2) + \frac{1}{L2} (e_3 - e_2) + C_3 \dot{e}_3 + \frac{1}{L3} e_3 = 0 \quad (6)$$

and are identical in format to Equations (3) and (4). Figure 6 is the electrical analog of the mechanical network shown in Figure 5. The analog relationships generated are shown in Table III.

Table III. Mechanical/Electrical Analogs (Translational)

Mechanical	Electrical	Relationship
Force (F)	Current (I)	$I = F$
Velocity (V)	Voltage (V)	$V = V$
Spring Stiffness (K)	Inductance (L)	$L = 1/K$
Friction (B)	Resistance (R)	$R = 1/B$
Mass (M)	Capacitance (C)	$C = M$

The dual relationships exist for the rotational case and the resulting conversion is shown in Table IV.

Table IV. Mechanical/Electrical Analogs (Rotational)

Mechanical	Electrical	Relationship
Torque (T)	Current (I)	$I = T$
Angular Velocity (W)	Voltage (V)	$V = W$
Spring Stiffness (K)	Inductance (L)	$L = 1/K$
Friction (B)	Resistance (R)	$R = 1/B$
Moment of Inertia (J)	Capacitance (C)	$C = J$

The analogous quantities in the table are used directly by NELSIM to obtain an electrical analog for a given mechanical system. The non-electrical symbols in the system are replaced by their electrical counterparts and thus readied for analysis using a circuit analysis program. The subroutines utilized to achieve this are discussed in Section V.

b. Thermal/Electrical Analogs

Whenever a temperature gradient exists within a system, or when two systems at different temperatures are brought into contact, energy is

transferred. The process by which the energy transport takes place is known as heat transfer. The quantity in transit, called heat, cannot be measured or observed directly, but the effects it produces are amenable to observation and measurement. The flow of heat, as in the performance of work, is a process by which the internal energy of a system is changed. Systems which are primarily concerned with the transfer of heat or thermal energy can be classified as thermal systems.

The two primary elements in a thermal system are the portions that act as heat dissipators (providing thermal resistance) and the portions that act as heat reservoirs (providing thermal capacitance). These elements are connected to various heat sources and heat sinks (points of varying temperatures) which provide the potential for the heat flow and are related to the rate of that heat flow $q(t)$ as shown by Equations (7) and (8).

$$q(t) = C_T \frac{dT}{dt} \quad (7)$$

$q(t)$ = the rate of heat flow where $C_T = C_p M$, C_T = the thermal capacitance of the mass, C_p = specific heat, M = mass of the body, and T = temperature of body.

$$q(t) = \frac{1}{R_T} T(t) \quad (8)$$

where R_T is the thermal resistance and may be expressed as $\frac{d}{KA}$ for a region of length d with uniform cross-sectional area A .

As seen above, the form of the equations describing the response of a

thermal system depends on the geometry, configuration and type of the system elements. In addition to these requirements, three distinct modes of heat transmission are recognized and must be specified. The three modes are conduction, convection and radiation.

The basic relation for heat transfer by conduction is given by

$$q_k = - KA \frac{dT}{dx} = \frac{dQ}{dt} \quad (9)$$

where q_k = rate of heat flow by conduction in a material,

K = thermal conductivity of the material,

A = area of the section through which heat flows by conduction, to be measured perpendicularly to the direction of heat flow, and

$\frac{dT}{dx}$ = the temperature gradient at the section.

The rate of heat transfer by convection between a solid surface and a fluid may be computed by the following relation:

$$q_c = \bar{h}_c A \Delta T = \frac{dQ}{dt} \quad (10)$$

where q_c = rate of heat transfer by convection,

A = heat transfer area,

ΔT = difference between the surface temperature T_s and a temperature of the fluid T_∞ at some specified location (usually far away from the surface), and

\bar{h}_c = average unit thermal conductance (often called the surface coefficient of heat transfer or the convection heat transfer coefficient).

Using the above equation, the thermal conductance K_c for convective heat transfer can be defined as

$$K_c = \bar{h}_c A \quad (11)$$

and the thermal resistance to convective heat transfer R_c , which is equal to the reciprocal of the conductance, can be defined as

$$R_c = \frac{1}{\bar{h}_c A} \quad (12)$$

The rate of heat transfer by radiation between two bodies is given by the following relation

$$q_r = \sigma A_1 f_{1-2} (T_1^4 - T_2^4) \quad (13)$$

where q_r = net rate of heat transfer by radiation,

σ = Stefan-Boltzmann constant (0.1714×10^{-8} Btu/hr ft²R⁴),

A_1 = surface area of body 1, and

f_{1-2} = a modulus which modifies the equation for perfect radiators to account for the emissivities and relative geometries of the actual bodies.

In many engineering problems, radiation is combined with other modes of heat transfer. The solution of such problems can often be simplified by using a thermal conductance K_r , or a thermal resistance R_r , for radiation. If the heat transfer by radiation is written as

$$q_r = K_r (T_1 - T_2) \quad (14)$$

the conductance, by comparison with the previous equation, is given by

$$K_r = \frac{\sigma A_1 f_{1-2} (T_1^4 - T_2^4)}{T_1 - T_2} \quad (15)$$

and the unit thermal conductance for radiation \bar{h}_r by

$$\bar{h}_r = \frac{K_r}{A} = \frac{\sigma f_{1-2} (T_1^4 - T_2^4)}{T_1 - T_2} \quad (16)$$

where T_2 is any convenient reference temperature.

The units applicable to thermal systems that will be accepted by the module are listed in Table V.

Table V. Thermal Units

Symbol	Description	Unit
T	Temperature	°F
q	Rate of Heat Flow	Btu /sec
Q _t	Heat Energy	Btu
t	Time in Thermal Circuit	sec
R _t	Thermal Resistance	(°F)(sec)(Btu)
C _t	Thermal Capacitance	Btu/°F

As an example consider Figure 7 which is used to illustrate the derivative of a set of differential equations for a thermal system.

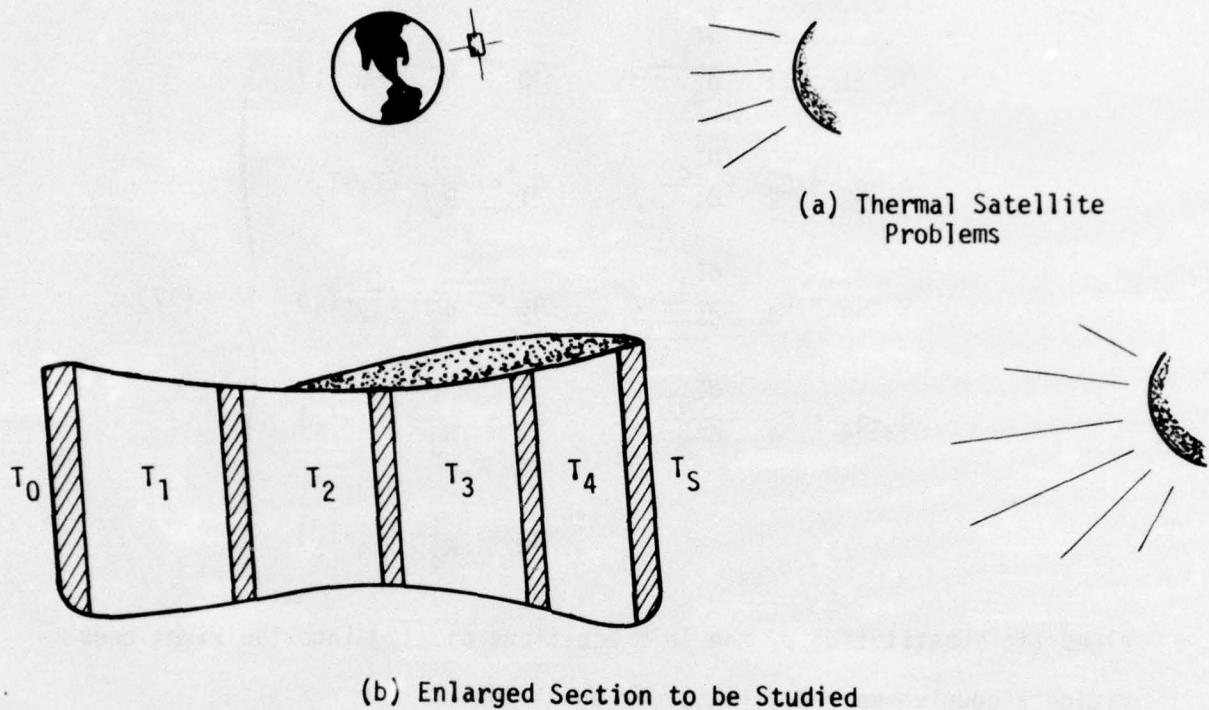

Figure 7. Thermal System Example

In the thermal system example, Figure 7 illustrates an orbiting satellite with one outer wall facing the sun and one facing the earth. It is desired to determine the temperature within its four adjacent compartments (the two outside temperatures are known). If the compartment walls are characterized with thermal resistances of R_0 , R_1 , R_2 , and R_4 and each compartment containing thermal capacitances of C_1 , C_2 , C_3 and C_4 and temperatures T_1 , T_2 , T_3 and T_4 respectively, the thermal analysis model is given by the following equations:

$$\left. \begin{aligned}
 q_0 - q_1 &= C_1 \frac{dT_1}{dt}, & q_0 &= \frac{1}{R_0} (T_0 - T_1) \\
 q_1 - q_2 &= C_2 \frac{dT_2}{dt}, & q_1 &= \frac{1}{R_1} (T_1 - T_2) \\
 q_2 - q_3 &= C_3 \frac{dT_3}{dt}, & q_2 &= \frac{1}{R_2} (T_2 - T_3) \\
 q_3 - q_4 &= C_4 \frac{dT_4}{dt}, & q_3 &= \frac{1}{R_3} (T_3 - T_4) \\
 & & q_4 &= \frac{1}{R_4} (T_4 - T_S)
 \end{aligned} \right\} (17)$$

Algebraic substitution of the left Equations of (17) into the right ones yields a coupled set of first order equations.

$$\left. \begin{aligned}
 C_1 \frac{dT_1}{dt} &= \frac{1}{R_0} (T_0 - T_1) - \frac{1}{R_1} (T_1 - T_2) \\
 C_2 \frac{dT_2}{dt} &= \frac{1}{R_1} (T_1 - T_2) - \frac{1}{R_2} (T_2 - T_3) \\
 C_3 \frac{dT_3}{dt} &= \frac{1}{R_2} (T_2 - T_3) - \frac{1}{R_3} (T_3 - T_4) \\
 C_4 \frac{dT_4}{dt} &= \frac{1}{R_3} (T_3 - T_4) - \frac{1}{R_4} (T_4 - T_S)
 \end{aligned} \right\} (18)$$

Analysis of the electrical network shown in Figure 8 results in equation set (19) below which is identical in form to Equation set (18).

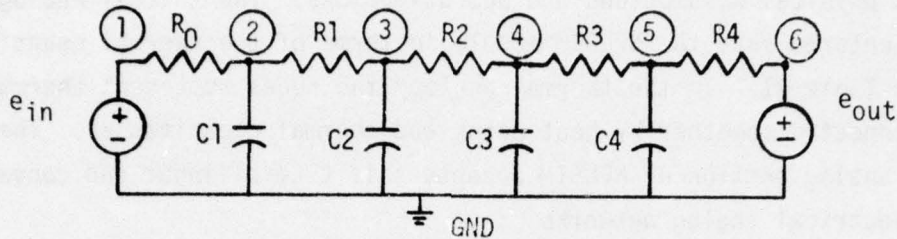

Figure 8. Thermal Example Analog

$$\begin{aligned}
 C_1 \frac{de_1}{dt} &= \frac{1}{R_0} (e_{in} - e_1) - \frac{1}{R_1} (e_1 - e_2) \\
 C_2 \frac{de_2}{dt} &= \frac{1}{R_1} (e_1 - e_2) - \frac{1}{R_2} (e_2 - e_3) \\
 C_3 \frac{de_3}{dt} &= \frac{1}{R_2} (e_2 - e_3) - \frac{1}{R_3} (e_3 - e_4) \\
 C_4 \frac{de_4}{dt} &= \frac{1}{R_3} (e_3 - e_4) - \frac{1}{R_4} (e_4 - e_{out})
 \end{aligned}
 \tag{19}$$

The thermal to electrical analogues are shown in Table VI.

Table VI. Thermal/Electrical Analogues

Thermal	Electrical	Relationship
Temperature (T)	Voltage (V)	$V = T$
Heat Flow (Q)	Current (I)	$I = Q$
Thermal Resistance (R_T)	Electrical Resistance (R_E)	$R_E = R_T$
Thermal Capacitance (C_T)	Electrical Capacitance (C_E)	$C_E = C_T$

The practical approach to thermal problems of significant complexity is to let the user generate the thermal analog of his system based on required physical assumptions and approximations. The thermal analog can then be entered into the NELSIM module in terms of the thermal quantities given in Table VI. In the thermal analogy the nodes represent thermal areas connected together by heat paths and thermal capacitances. The thermal analog portion of NELSIM accepts this type of input and converts it to electrical analog networks .

c. Electro-Mechanical/Electrical Analogs

Electro-mechanical systems are composed of both electrical and mechanical devices. The interface or coupling between the electrical and mechanical portions of the system is effected by means of electro-mechanical transducers. A transducer is a device which converts energy from one form to another, or which converts a system variable from one form to another (e.g., a generator converts mechanical energy to electrical energy and a motor converts electrical energy to mechanical energy). The basis for electro-mechanical transducers is the interaction of mechanical forces and magnetic or electrical fields. Thus, the unique features of analysis for electro-mechanical systems reduces to the study of electro-mechanical coupling through magnetic and/or electric fields.

The elements of an electro-mechanical system can be visualized as consisting of three basic types as illustrated in Figure 9: electrical network elements, mechanical system elements, and electro-mechanical coupling elements



Figure 9. An Electro Mechanical System

The differential equations describing the behavior of an electro-mechanical system are based on the assumption of the validity of a lumped parameter electro-mechanical system. In the context used here lumped parameter systems are defined as follows: the electromagnetic fields are

quasistatic and electrical terminal properties can be described as functions of a finite number of electrical variables. Also, the mechanical effects can be described by a finite number of mechanical variables. Kirchoff's laws can then be written for the electrical parts of the system by introducing electro-mechanical coupling effects through the terminal relations of the coupling system. Similarly, Newton's second law and continuity of space for the mechanical parts of the system can be written, including electro-mechanical coupling effects in the terminal relations of the coupling system.

The NELSIM program allows the user to define the purely electrical circuit portion of the system in terms of the standard electrical elements (resistance, capacitance and inductance), the purely mechanical portion of the system in terms of the standard mechanical elements (mass, spring and dampers), and the coupling terminals in terms of the magnetic flux (or electrical charge for an electric field system).

From the input description NELSIM derives the electrical equivalent of the electro-mechanical system. The first step is to transform the mechanical portion of the system into an electrical equivalent. This can be done utilizing the method presented in Part a. of this section. The second step is to connect the electrical portion of the system to the generated electrical analog of the mechanical portion through elements and equations expressing the coupling between the two portions. To illustrate, consider the galvanometer sketch provided in Figure 10. A galvanometer ideally produces a deflection that is proportional to an electrical input.

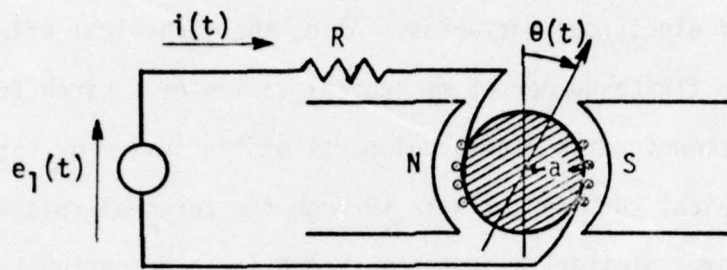

Figure 10. Galvanometer Schematic Representation

Figure 11 represents the equivalent lumped network in terms of its electrical and mechanical parts

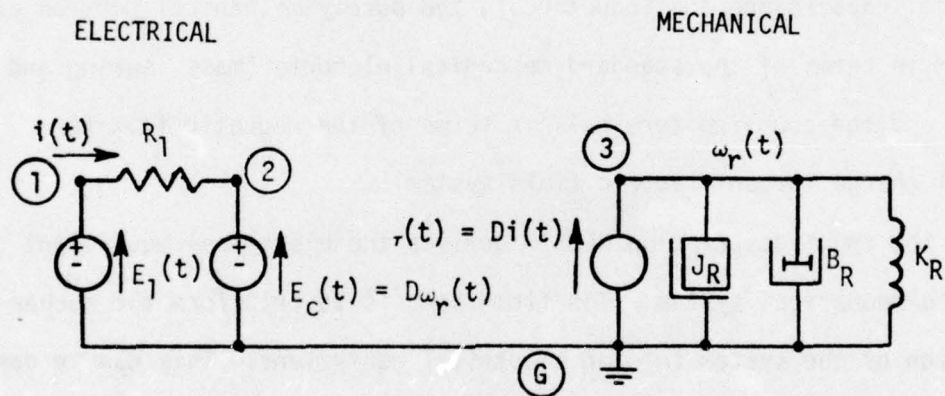

Figure 11. Lumped Element Galvanometer Equivalent

where J_R and B_R represent the moment of inertia of the rotor and the viscous damping that results from air friction. The element K_R represents the rotational stiffness produced by a spring attached to the rotor. The constant D is defined to be $\beta \lambda a$ where β is the magnetic flux density, λ is the total length of the conductor and a is the radius of the rotor. The two dependent sources E_c and E_1 provide the interface between the two

systems and are entered directly in terms of the elements involved. The electrical analog derived by NELSIM is shown in Figure 12. As can be seen, the network is entirely in terms of electrical quantities.

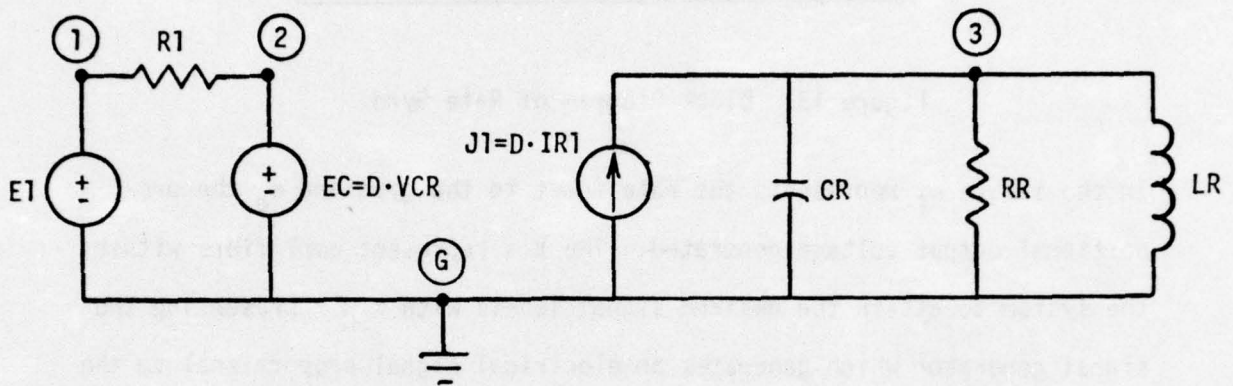

Figure 12. Galvanometer Electrical Analog

Most electro-mechanical systems can be modeled in terms of transfer functions and a user has the option of entering the system in terms of a signal flowgraph (Section III). Models with general usage, however, can be easily included in the NELSIM code. To illustrate this option two models have been built into NELSIM and are discussed below.

(1) Rate Gyro Model

Rate gyros are used widely in any application requiring tracking and stabilization. Aircraft and missiles utilize gyros for stabilization when angular deviations are noticed. Rate gyros are also used extensively in conjunction with tracking antennas so that the angular velocity of the tracked vehicle can be measured. A mathematical block diagram of a rate gyro is given in Figure 13.

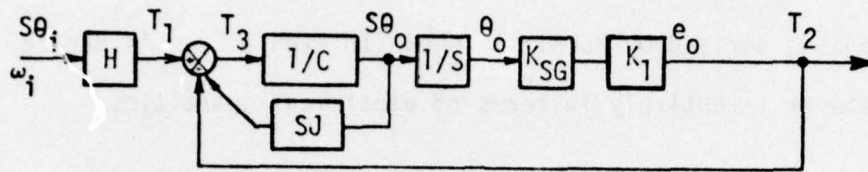

Figure 13. Block Diagram of Rate Gyro

In the figure ω_i represents the rate input to the gyro and e_o the proportional output voltage generated. The K's represent amplifiers within the system to attain the desired signal levels with K_{SG} representing the signal generator which generates an electrical signal proportional to the displacement angle θ_o . The transfer function between T2 and T1 is calculated as follows:

$$\frac{T2}{T1} = \frac{\frac{K/C}{S(1 + \frac{J}{C} S)}}{1 + \frac{K/C}{S(1 + \frac{J}{C} S)}}$$

when simplified the above equation becomes

$$\frac{T2}{T1} = \frac{1}{1 + \frac{C}{K} S + \frac{J}{K} S^2}$$

The above represents the closed loop transfer function of the rate gyro which can be recognized as having the form

$$F(S) = \frac{1}{1 + \frac{2\xi}{\omega_n} S + \frac{1}{\omega_n^2} S^2}$$

where ξ is the damping factor and ω_n the natural frequency. Like terms yield

$$\omega_n = \sqrt{\frac{K}{J}} \text{ and } \xi = \frac{C}{2\sqrt{KJ}}$$

which allows the user to adjust both of these quantities by adjusting the various gains.

The model equivalent for NELSIM input is shown in Figure 14 where $PB = 1/C$ and $PC = J$. The feedback gain PF has been added for further generalization of the model and if set equal to one will result in the transfer function derived above.

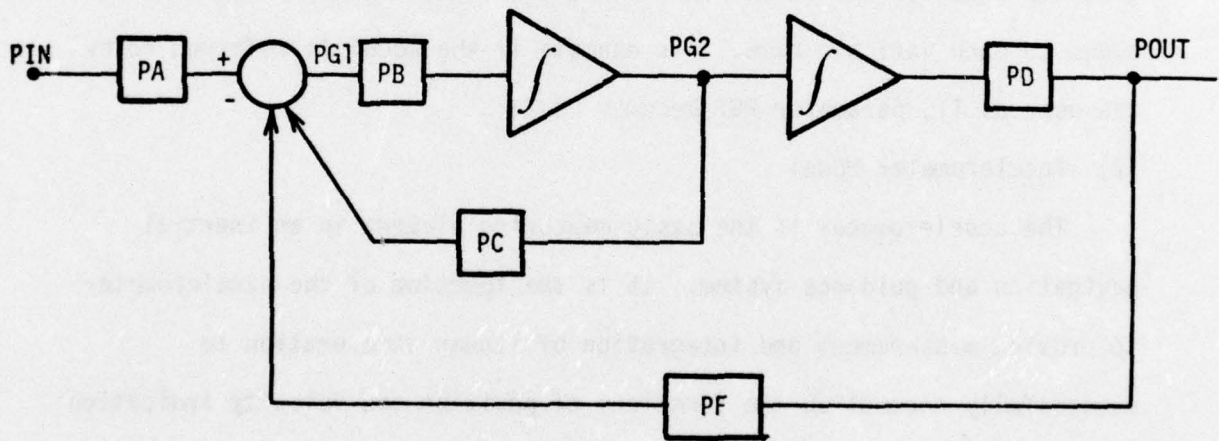

Figure 14. NELSIM Equivalent Rate Gyro

Solution of the model requires breaking the equations applicable down to a set of first order differential equations algebraically coupled together. Equation (20) gives the results of each summing junction.

$$\begin{aligned}
 PG1 &= PIN \cdot PA - POUT \cdot PF - PG2 \cdot PC \\
 PG2 &= PG1 \cdot PB \cdot \frac{1}{S} \\
 POUT &= PG2 \cdot PD \cdot \frac{1}{S}
 \end{aligned}
 \quad \left. \vphantom{\begin{aligned} PG1 \\ PG2 \\ POUT \end{aligned}} \right\} \quad (20)$$

Solution for the highest order derivatives and rearranging (20) yields Equation set (21).

$$\begin{aligned}
 PG1 &= PIN \cdot PA - POUT \cdot PF - PG2 \cdot PC \\
 \dot{PG2} &= PG1 \cdot PB \\
 \dot{POUT} &= PG2 \cdot PD
 \end{aligned}
 \quad \left. \vphantom{\begin{aligned} PG1 \\ \dot{PG2} \\ \dot{POUT} \end{aligned}} \right\} \quad (21)$$

A call to the gyro model from the input language triggers the program to generate Equation set (21). The name given to the model by the user is added to each variable name. For example if the model is referred to by the user as T1, parameter PG7 becomes PG7T1.

(2) Accelerometer Model

The accelerometer is the basic measuring element in an inertial navigation and guidance system. It is the function of the accelerometer to provide measurement and integration of linear acceleration to successfully accomplish the functions of position and velocity indication and generation of proper steering signals. Although numerous models are available the double integrating accelerometer shown in Figure 15 has been implemented into NELSIM.

In the model a_i represents the input acceleration, e_o the signal voltage generated and $\ddot{\theta}$ the angular acceleration of the motor shaft resulting from the application of e_o . The double integration of the angular velocity ($\ddot{\theta}$) yields the angular velocity ($\dot{\theta}$) and relative angle (θ) of the shaft. These two quantities are proportional to the craft

velocity (V) and distance traveled (X). The mathematical formulation is given below.

$$\begin{aligned} \frac{T_3}{T_2} &= \frac{(K_2 K_{SG} K_4) S}{S \left(1 + \frac{K_3}{K_2} S\right) (1 + K_5 S) + (K_2 K_{SG} K_4) S} \\ &= \frac{N}{1 + aS + bS^2 + N} \end{aligned}$$

where:

$$N = (K_2 K_{SG} K_4) S$$

$$a = \frac{K_3}{K_2} + K_5$$

$$b = \frac{K_3 K_5}{K_2}$$

Inserting $T = K_1 a_i$ and applying the final value theorem for an assured step input yields

$$T_3 = K K_1 a_i$$

in the steady state which shows the angular acceleration of the shaft to be proportional to the input acceleration. Another relationship exists for T_3 , namely

$$T_3 = K_6 \omega S^2$$

equating the two yields

$$K K_1 a_i = K_6 \omega S^2$$

To determine velocity and distance changes as a function of a_i both sides of this equation are integrated.

$$KK_1 \Delta V = KK_1 \int_0^t a_i dt = K_6 \int_0^t \Delta \theta dt$$

$$K \Delta X = KK_1 \int_0^t \int_0^t a_i dt = K_6 \int_0^t \int_0^t \Delta \theta dt$$

$$\Delta V = \frac{K_6 \Delta \theta}{KK_1}$$

$$\Delta X = \frac{K_6 \Delta \theta}{KK_1}$$

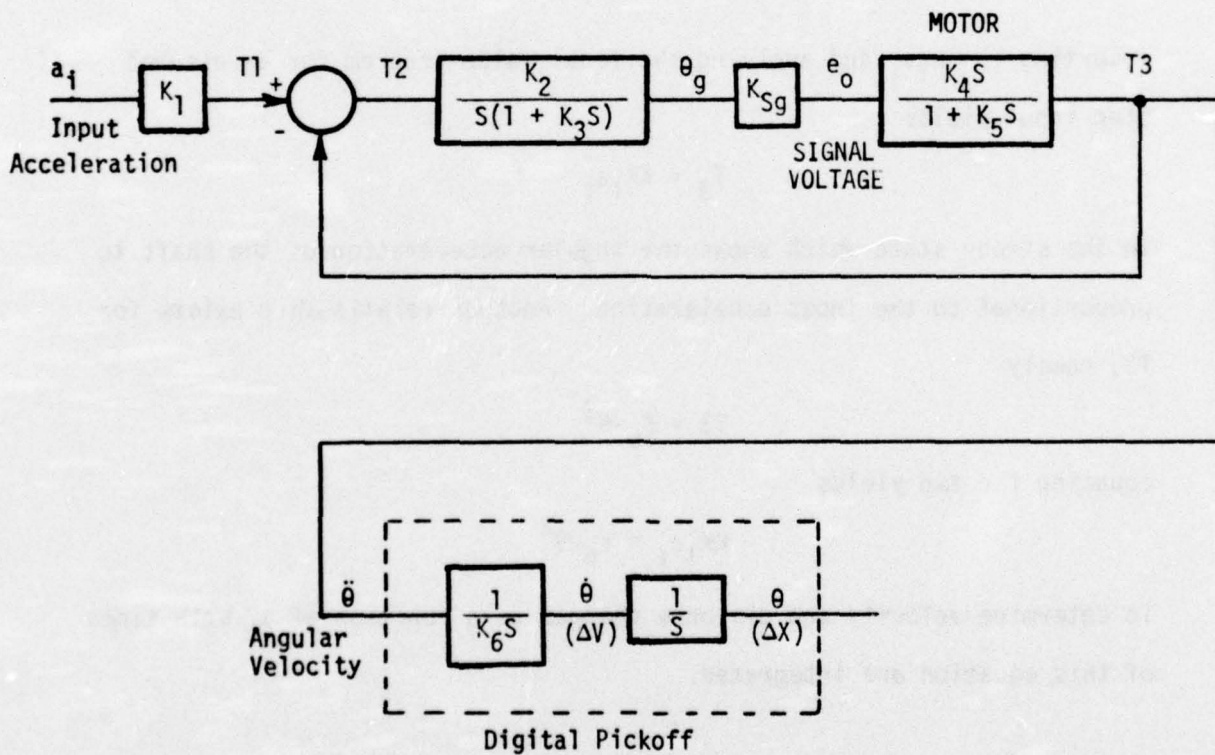

Figure 15. Accelerometer Model

The model programmed into NELSIM is illustrated in Figure 16.

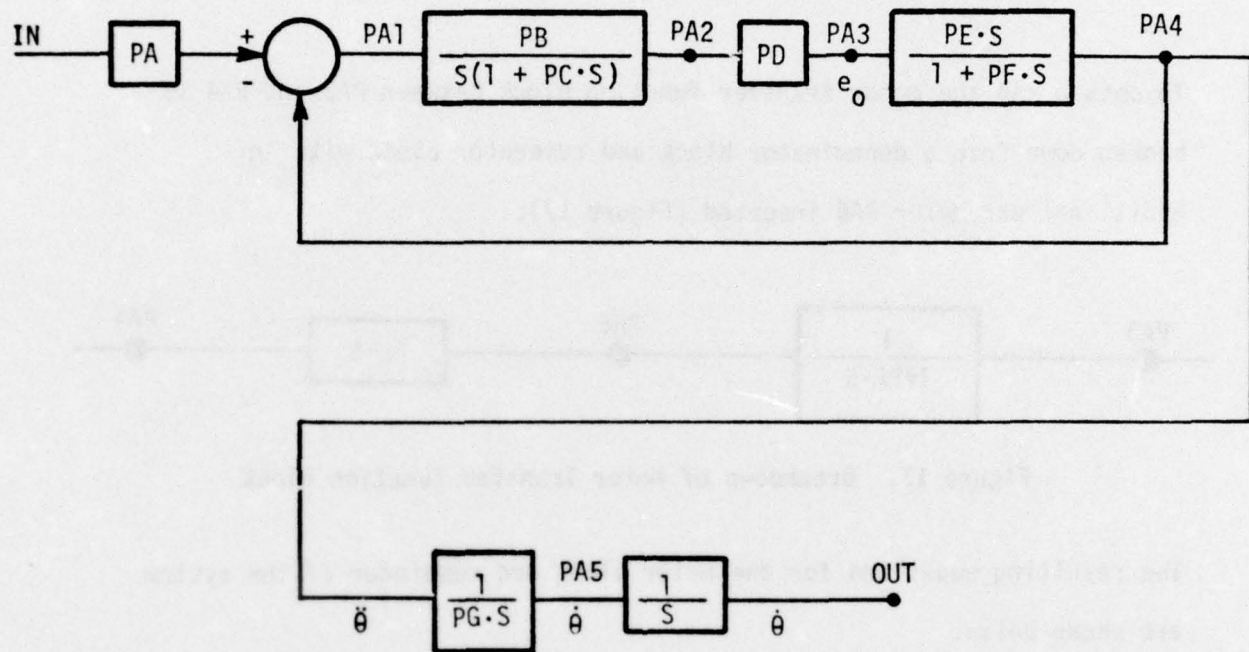

Figure 16. NELSIM Accelerometer Equivalent

The equations obtained at the summing junctions are shown below.

$$PA1 = PIN \cdot PA - PA4$$

$$PA2 = PA1 \cdot \frac{PB}{S(1+PC \cdot S)}$$

$$PA3 = PA2 \cdot PD$$

To obtain PA4 the motor transfer function block between PA3 and PA4 is broken down into a denominator block and numerator block with an additional parameter PA6 inserted (Figure 17).

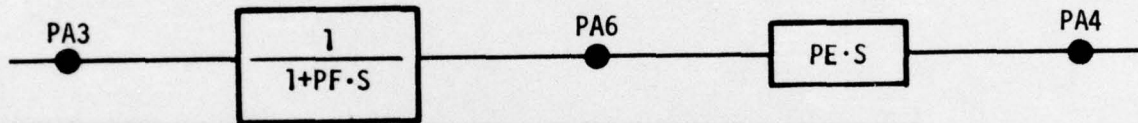

Figure 17. Breakdown of Motor Transfer Function Block

The resulting equations for the motor block and remainder of the system are shown below.

$$PA6 = PA3 \cdot \frac{1}{1+PF \cdot S}$$

$$PA4 = PA6 \cdot PE \cdot S$$

$$PA5 = PA4 \cdot \frac{1}{S} \cdot \frac{1}{PG}$$

$$POUT = PA5 \cdot \frac{1}{S}$$

Multiplying the above equations out and solving for the highest order derivatives yield Equation set (22).

$$\begin{aligned}
 PA1 &= PIN \cdot PA - PA4 \\
 PA2 &= (PA1 \cdot PB - \dot{PA}2) / PC \\
 PA3 &= PA2 \cdot PD \\
 \dot{PA}6 &= (PA3 - PA6) / PF \\
 PA4 &= \dot{PA}6 \cdot PE \\
 \dot{PA}5 &= PA4 / PG \\
 \dot{P}OUT &= PA5
 \end{aligned}
 \tag{22}$$

Rearranging Equation set (22) and breaking down n number equations to n first order differential equations yields the set of Equations (23) shown below.

$$\begin{aligned}
 PA1 &- PIN \cdot PA - PA4 \\
 \dot{PA}2 &= PA7 \\
 \dot{PA}7 &= (PA1 \cdot PB - PA7) / PC \\
 \dot{PA}3 &= PA2 \cdot PD \\
 \dot{PA}6 &= (PA3 - PA6) / PF \\
 PA4 &= PE \cdot (PA3 - PA6) / PF \\
 \dot{PA}5 &= PA4 / PG \\
 \dot{P}OUT &= PA5
 \end{aligned}
 \tag{23}$$

A call to the accelerometer model triggers the program to generate Equation set (23). The program adds to each parameter involved the name assigned to the model by the user. For example, referral to the model as M1 will result in the letters M1 being added to each parameter (i.e., PA4M1).

d. Electro-Optical/Electric Analogs

The majority of photodetectors in use today are photo emissive diodes, photo conductive diodes, or PIN and PN photo diodes. Photo emissive diodes typically have low quantum efficiencies, while photo conductive diodes have low cut-off frequencies. These properties have tended to push the using community towards photo diodes except where special applications make the other devices specifically attractive. A direct result of this trend has produced a large quantity of photo diode data, devices and literature, and lesser quantities of the other device types.

The NELSIM translator has been constructed to handle photo diode type devices, simulating the AC characteristics of a device with an equivalent electric circuit. Circuit representation is shown in Figure 18.

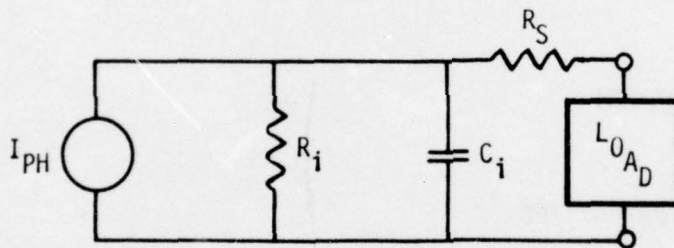

Figure 18. Equivalent Circuit of a Photodiode

Referring to the figure, I_{PH} represents the AC photocurrent generated by the photo diode when excited by a light energy source. R_S , R_i , and C_i are the equivalent resistance and capacitance that characterize the device. Table VII presents performance characteristics for widely used photo diodes.

The photocurrent can be determined from light energy time histories using perfect-square law detector formulation. Typically, the photo current is expressed as some function of the quantum efficiency and average number of incident photons per unit,

time, such as

$$I_{PH} \sim (\eta q P / h\nu)$$

where,

η = quantum efficiency

$P/h\nu$ = average number of incident photons per unit time

I_{PH}/q = average number fps unit time of electrons emitted from the photocathode

Since the device response is dependent upon the frequency of the energy source it is best to construct a circuit for frequency bands and sum the produced current linearly, or to restrict the analysis to a certain frequency band. Figure 19 details the effect of frequency on quantum efficiency for various photodiode devices.

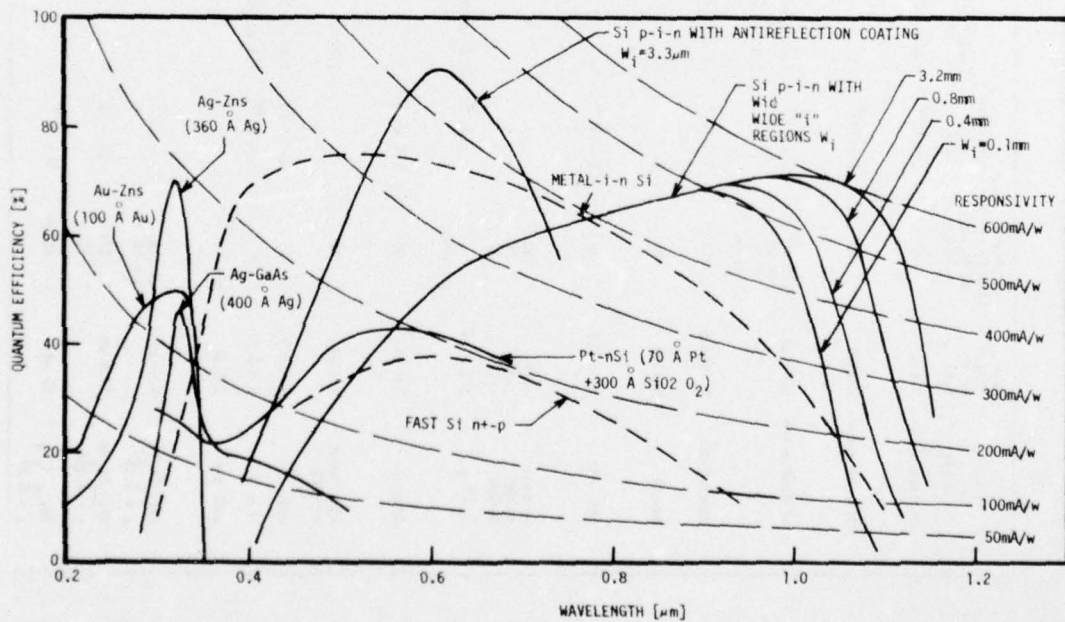

Figure 19. Wavelength Dependence of Quantum Efficiency and Responsivity for Several High Speed Photodiodes.

Table VII. Performance Characteristics of Photodiodes

Diode	Wave-length Range (μm)	Peak Efficiency (%) or Responsivity	Sensitive Area (cm^2)	Capacitance (pF)	Series Resistance (Ω)	Response Time (seconds)	Dark Current	Operating Temperature (K)	Comments
SiIicon n ⁺ -p	0.4-1	40	2×10^{-5}	0.8 at -23 V	6	130 ps with 50- Ω load	50 pA at -10 V	300	avalanche photo-diode
SiIicon p-I-n	0.6328	>90	2×10^{-5}	<1	<1	100 ps with 50- Ω load	$<10^{-9}$ A at -40 V	300	optimized for 0.6328 A
SiIicon p-I-n	0.4-1.2	>90 at 0.9 μm >70 at 1.06 μm	5×10^{-2}	3 at -200 V 3 at -200 V	<1	7 ns 7 ns	0.2 μA at -30 V	300	
MetaI-I-nSi	0.38-0.8	>70	3×10^{-2}	15 at -100 V		10 ns with 50- Ω load	2×10^{-2} A at -6 V	300	
Au-nSi	0.6328	70	2			<500 ps		300	Schottky barrier antireflection coating
PtSi-nSi	0.35-0.6	40	2×10^{-5}	<1		120 ps		300	Schottky barrier avalanche photo-diode
Ag-GaAs Ag-ZnS Au-ZnS	<.36 <.35 <.35	50 70 50						300 300 300	
Ge n ⁺ -p	0.4-1.55	50 uncoated	2×10^{-5}	0.8 at -16 V	<10	120 ps	2×10^{-8}	300	Germanium avalanche photo-diode
Ge p-I-n	1-1.65	60	2.5×10^{-5}	3		25 ns at 500 V		77	illumination entering from side
GaAs point contact	0.6328	40	0.027		30				
InAs p-n	0.5-3.5	>25	3.2×10^{-4}	3 at -6 V	12	< 10^{-6}		77	
InSb p-n	0.4-6.5	>25	5×10^{-4}	7.1 at -0.2 V	18	5×10^{-6}		77	
InSb p-n	2-6.6	5×10^{-4}					1M Ω shunt resistance	77	Reverse break down voltages 30 V
Pb _{1-x} Sn _x Te x = 0.16	9.5 μm	45 V/W n = 60	4×10^{-3}			10^{-9}		77	shunt resistance $R_1 = 10 \Omega$
Pb _{1-x} Sn _x Se x = 0.064	11.4 μm	3.5 V/W n = 15	7.8×10^{-3}			10^{-9}		77	shunt resistance $R_1 = 2.5 \Omega$
Hg _{1-x} Cd _x Te x = 0.17	15 μm	n = 10-30	4×10^{-4}		8	$<3 \times 10^{-9}$		77	shunt resistance $R_1 > 100 \Omega$

e. Units and Scaling

The following paragraphs document steps taken to implement units and a scaling algorithm into NELSIM. In order to allow NELSIM to be completely compatible with SCEPTRE in the flexibility of its input language the scaling module is semi automated and requires user interaction.

(1) Units

SCEPTRE allows any set of parameter units as long as the element magnitudes with respect to these are consistent. To keep the two input languages consistent, the same is true of NELSIM. The user is allowed to enter a problem in any set of units he chooses and is responsible for compatibility throughout his system.

(2) Scaling Guidelines and Automation

One of the problems encountered in system analysis utilizing numerical integration is that of maintaining a consistent set of parameter units such that the magnitudes of all the solution variables are consistent with the specified error criteria. Numerical inaccuracies result and excessive solution time is spent when units are not carefully chosen due to the difficulties in meeting specified error criteria. Previous experience in the system analysis area and application of SCEPTRE and other codes to large scale circuit and system problems has shown that it is desirable to maintain the magnitude of the solution variables in the range between 10^{-3} and 10^3 . For example, voltage and current are the two solution variables used by SCEPTRE and it is desirable to keep these variables within the limits shown below.

$$10^{-3} \leq |V| \leq 10^3$$

$$10^{-3} \leq |I| \leq 10^3$$

The desired magnitude ranges can be accomplished through knowledge of the basic laws governing a particular system and a knowledge of the ranges expected. If the expected units of the solution variables and time are known, the system element units can be scaled to yield those units. The above is exemplified through a high-speed transistorized circuit in which the response is known to be in terms of volts, milliamps and nanoseconds. The equations below illustrate the applicable relationships between state variables and electrical elements.

$$R = \frac{V}{I}$$

$$C = I \frac{dt}{dv}$$

$$L = V \frac{dt}{di}$$

Where: V = Voltage

I = Current

R = Resistance

C = Capacitance

L = Inductance

To obtain the response in terms of volts, milliamps and nanoseconds the elements are scaled as follows:

$$R = \frac{V}{I} = \frac{\text{Volts}}{\text{ma}} = \frac{1}{10^{-3}} = 10^3 \text{ (kilohms)}$$

$$C = I \frac{dt}{dv} = \text{ma} \cdot \frac{\text{nsec}}{\text{Volts}} = \frac{(10^{-3})(10^{-9})}{1} = 10^{-12} \text{ (Picofarads)}$$

$$L = V \frac{dt}{di} = \text{Volts} \cdot \frac{\text{nsec}}{\text{ma}} = \frac{(1)(10^{-9})}{10^{-3}} = 10^{-6} \text{ (microhenries)}$$

Definition of the network elements in terms of these units brings the solution variables closer to their desired range.

The same procedure is applicable to other systems. The equations shown below present the relationships necessary for mechanical and thermal systems.

MECHANICAL SYSTEMS

$$B = \frac{F}{V}$$

$$M = F \frac{dt}{dV}$$

$$K = \frac{1}{V} \frac{dF}{dt}$$

Where: V = Velocity

F = Force

M = Mass

K = Spring Constant

B = Viscosity/
Friction

THERMAL SYSTEM

$$C = Q \frac{dt}{dT}$$

$$R = \frac{T}{Q}$$

Where: Q = rate of heat
flow

C = Thermal Capacitance

R = Thermal resistance

T = Temperature

(3) Automated Scaling

An algorithm was implemented within the NELSIM program to achieve scaling of a network. The program generates an electrical analog from various types of system inputs. The scaling algorithm scales all the elements to magnitudes consistent with user provided guidelines. The option requires the user to input the expected units of the solution variable and time. Table VIII shows the analogies between the various systems involved. Both mechanical and thermal quantities are translated into the electrical quantities shown in the table, such that in the translated network the only solution variables are electrical. The user will enter a problem in terms of the standard units familiar to the field involved. Table IX illustrates the units that are expected if the scale option is utilized.

TABLE VIII. SYSTEM ANALOGIES

SYSTEM FUNCTION	ELECTRICAL	MECHANICAL		THERMAL
		Translational	Rotational	
SOLUTION VARIABLES	Voltage	Velocity	Angular Velocity	Temperature
	Current	Force	Torque	Heat Flow
TIME	Time	Time	Time	Time
ELEMENTS	Resistance	Friction	Friction	Thermal Resistance
	Capacitance	Mass	Moment of Inertia	Thermal Capacitance
	Inductance	Spring Stiffness	Spring Stiffness	

TABLE IX. STANDARD SYSTEM UNITS

PHYSICAL MEDIUM	ELEMENTS	SYMBOL	STANDARD	UNITS		
				MKS	ENGLISH	BTU
Electrical	Resistance	R	Ohms			
	Capacitance	C	Farads			
	Inductance	L	Henries			
Mechanical	Mass	M		Kilogram	Slug	
	Spring Stiffness	K		Newton/ meter	lb/ft	
	Friction	B		n-sec/m	lb/ft	
	Moment of Inertia	J		nm/ (rad/sec ²)	ft lb/ (rad/sec ²)	
	Angular Velocity	W		rad/sec	rads/sec	

TABLE IX. (CONTINUED)

PHYSICAL MEDIUM	ELEMENTS	SYMBOL	STANDARD	MKS	ENGLISH	BTU
Thermal	Temperature	T				$^{\circ}\text{F}$
	Heat flow rate	Q				Btu/sec
	Capacitance	C				Btu/ $^{\circ}\text{F}$
	Resistance	R				Btu/ $^{\circ}\text{F}/\text{lb}$

The user must indicate the scaling to be performed by entering the expected magnitudes of the solution variables and time. For example consider the electronic network discussed earlier entered in terms of the standard elements shown in Table VIII. To obtain the solution in terms of volts, milliamps and nanoseconds the network must be scaled. The user input would consist of the card shown below which states that the scaling option is desired

SCALE OPTION, VOLTAGE=1, CURRENT=10E-3, TIME=10E-9

such that the voltage is to remain in terms of volts but current and time are to be scaled to milliamps and nanoseconds, respectively. Use of this scaling option for all system components will maintain a consistent set of variable values.

The output of the program consists of two listings. The first is a listing of the analog network generated with no scaling applied. The second consists of the analog network with all constant elements scaled and a list of the scale factors used on the elements. The user is then required to scale all non-constant element values to complete the scaling task. This requirement is a result of the flexibility of the input

language given to the user to keep the program consistent with SCEPTRE. Due to this flexibility the user has the ability to camouflage non-unitless quantities, as will be illustrated. One of the allowed input formats of NELSIM is the definition of an element as a Fortran function subroutine. The subroutine may contain non-unitless quantities which would have to be scaled. Yet the program cannot possibly determine the units of these parameters and any attempt at scaling these could result in gross error. Consider the case of a voltage dependent resistor entered as follows:

```
R1,1-2=FUNCTION R(ET)
```

where the Function R is described as

```
FUNCTION R(X)  
R = 10.*X  
RETURN  
END
```

The constant 10. is in units of $\frac{1}{\text{amperage}}$ and any scaling of current would demand a scaling of this constant. The program, however, has no access to the function and no way of knowing about the constant. For this reason, the task of altering the function will be left to the user.

A completely automatic scaling algorithm would demand a severe reduction in the flexibility of the input language which would in turn defeat the purpose of keeping the program compatible with transient analysis programs.

SECTION III
DIFFERENTIAL EQUATIONS

Section II points out that differential equations are a very general form of system definition. This section presents differential equation capabilities which are built into NELSIM.

The NonElectrical Languages Simulation Module accepts coupled sets of nonlinear (or linear) differential equations of the form given by equation (24).

$$\begin{bmatrix} a_{11} & a_{12} & \dots & a_{1m} \\ \vdots & \vdots & \ddots & \vdots \\ a_{m1} & \dots & \dots & a_{mm} \end{bmatrix} \cdot \begin{bmatrix} \left(\frac{d^n x_1}{dt^n}\right)^i \\ \vdots \\ \left(\frac{d^n x_2}{dt^n}\right)^j \\ \vdots \\ \left(\frac{d^n x_m}{dt^n}\right)^k \end{bmatrix} + \begin{bmatrix} b_{11} & b_{12} & \dots & b_{1m} \\ \vdots & \vdots & \ddots & \vdots \\ b_{m1} & \dots & \dots & b_{mm} \end{bmatrix} \cdot \begin{bmatrix} \left(\frac{d^{n-1} x_1}{dt^{n-1}}\right)^i \\ \vdots \\ \left(\frac{d^{n-1} x_2}{dt^{n-1}}\right)^j \\ \vdots \\ \left(\frac{d^{n-1} x_m}{dt^{n-1}}\right)^k \end{bmatrix}$$

$$+ \dots + \begin{bmatrix} c_{11} & c_{12} & \dots & c_{1m} \\ \vdots & \vdots & \ddots & \vdots \\ c_{m1} & \dots & \dots & c_{mm} \end{bmatrix} \cdot \begin{bmatrix} (x_1)^i \\ \vdots \\ (x_2)^j \\ \vdots \\ (\dot{x}_m)^k \end{bmatrix} + \begin{bmatrix} d_1 \\ \vdots \\ d_m \end{bmatrix} = \begin{bmatrix} F_1 \\ F_2 \\ \vdots \\ F_m \end{bmatrix} \quad (24)$$

Equation (24) is a general set of m nonlinear differential equations in m unknowns, x_1 through x_m and with forcing functions F_1 through F_m . For convenience, the equations are represented in matrix form, but are input

into NELSIM individually. The term $\frac{d^n x_1^i}{dt^n}$ is the n th derivative

of the variable x_1 raised to the i th power where i can vary from 1 to i and is not necessarily the same for all derivative orders. For the systems considered in Section II, the highest order of derivative n generally encountered is two. The coefficients a_{11} , b_{11} , etc. may be time varying or nonlinear. It will be possible to enter the coefficients into NELSIM as constants, SCEPTRE type defined parameters, or algebraic expressions, e.g., the form $(3t^2 - t + 1)$.

NELSIM automatically takes equations of the form of Equation (24) and separate them into first order differential equations. It should be realized that to determine the transient response of the system represented by Equation (24), it will be necessary to integrate a number of equations equal to the total number of derivatives up to n derivatives for each unknown for a maximum of m times n equations to integrate. The maximum number of first order differential equations currently allowed in SCEPTRE for example is 100, and NELSIM warns the user if over 100 equations are generated. If the SCEPTRE limit were increased, NELSIM could be easily modified to accommodate the increase. Each n th order equation must be translated into n first order differential equations as shown below. Equation (24) is broken down to

$$\frac{d^n x}{dt^n} = f \left(\frac{d^{n-1} x}{dt}, \frac{d^{n-2} x}{dt}, \dots \dots \frac{dx}{dt}, C \right)$$

which is rewritten as Equation set (25).

$$\frac{dx}{dt} = x_1$$

$$\frac{dx_1}{dt} = x_2$$

$$\frac{dx_2}{dt} = x_3$$

⋮

$$\frac{dx_{m-1}}{dt} = x_m$$

$$\frac{dx_m}{dt} = f(x_m, x_{m-1}, \dots \dots, C)$$

(25)

As an example consider the two second order differential Equations 26 and 27 derived for the mechanical system of section IIa and repeated here for convenience.

$$K_1(V_2 - V_1) + M_2 \ddot{V}_2 + B(\dot{V}_2 - \dot{V}_3) + K_2(V_2 - V_3) = 0 \quad (26)$$

$$B(\dot{V}_3 - \dot{V}_2) + K_2(V_3 - V_2) + M_3 \ddot{V}_3 + K_3 V_3 = 0 \quad (27)$$

If entered into NELSIM according to the proper format, the program will proceed to solve each equation for the highest order derivative and from

these generate a set of four first order differential equations as shown below.

Solving for highest order derivatives yields:

$$\ddot{V}_2 = [K_1(V_2 - V_1) - B(\dot{V}_2 - \dot{V}_3) - K_2(V_2 - V_3)] / M_2 \quad (28)$$

$$\ddot{V}_3 = [K_2(V_3 - V_2) - B(\dot{V}_3 - \dot{V}_2) - K_3V_3] / M_3 \quad (29)$$

Breaking (28) and (29) into four first order differential equations yields:

$$\dot{V}_2 = V_{2A} \quad (30)$$

$$\dot{V}_{2A} = \ddot{V}_2 = [K_1(V_2 - V_1) - B(\dot{V}_2 - \dot{V}_3) - K_2(V_2 - V_3)] / M_2 \quad (31)$$

$$\dot{V}_3 = V_{3A} \quad (32)$$

$$\dot{V}_{3A} = \ddot{V}_3 = [K_2(V_3 - V_2) - B(\dot{V}_3 - \dot{V}_2) - K_3V_3] / M_3 \quad (33)$$

As shown, two new variables are generated in the process (V_{2A} and V_{3A}). Substitution of these two variables into Equations (31) and (32) yields the set of equations shown below.

$$\dot{V}_{2A} = V_{2A} \quad (34)$$

$$\dot{V}_{2A} = [K_1(V_2 - V_1) - B(V_{2A} - V_{3A}) - K_2(V_2 - V_3)] / M_2 \quad (35)$$

$$\dot{V}_{3A} = V_{3A} \quad (36)$$

$$\dot{V}_{3A} = [K_2(V_3 - V_2) - B(V_{3A} - V_{2A}) - K_3V_3] / M_3 \quad (37)$$

SECTION IV
TRANSFER FUNCTIONS

This section presents the transfer function capabilities which are built into NELSIM. A system defined in terms of linear, time invariant, ordinary differential equations can be represented by a transfer function which relates the system output to input in the Laplace transform domain using rational polynomials in the Laplace transform variable S . Conversely, given the transfer function of a real system as a rational polynomial in S , it is always possible to derive a set of first order differential equations with time as the independent variable whose solution is the transient response of the system for a given input. The purpose of the transfer function section of NELSIM is to provide the capability to input a connected set of block diagrams in which the individual blocks are rational polynomials in S . The program automatically derives the appropriate first order differential equations. The transient analysis program can then integrate the differential equations to provide the desired transient output.

For a transfer function of the form given by Equation (38)

$$G(s) = \frac{C(s)}{R(s)} = \frac{\sum_{i=0}^m a_i s^{m-i}}{\sum_{i=0}^n b_i s^{n-i}} \quad \text{for } n \geq m \quad (38)$$

where $C(s)$ is the Laplace transform of the output $C(t)$ and $R(s)$ is the Laplace transform of the forcing function $R(t)$, the following state

variable differential Equations (39) and single algebraic equation (40) define the transient response.

$$\begin{array}{l}
 \frac{dx_1}{dt} = x_2 \\
 \frac{dx_2}{dt} \\
 \vdots \\
 \frac{dx_{n-1}}{dt} = x_n
 \end{array}
 \quad \left. \vphantom{\begin{array}{l} \frac{dx_1}{dt} = x_2 \\ \frac{dx_2}{dt} \\ \vdots \\ \frac{dx_{n-1}}{dt} = x_n \end{array}} \right\} \quad (39)$$

$$\frac{dx_n}{dt} = \frac{1}{b_0} \left[R(t) - \sum_{i=1}^n b_i x_{n-i+1} \right]$$

$$C(t) = \sum_{i=0}^m a_i x_{m-i+1} \quad (40)$$

The set of Equations (39) and (40) are developed automatically by NELSIM for each transfer function entered. The interface between transfer functions is taken care of by the nodal connections.

As an example of the transfer function capability in NELSIM, consider the unity feedback system shown in Figure 20.

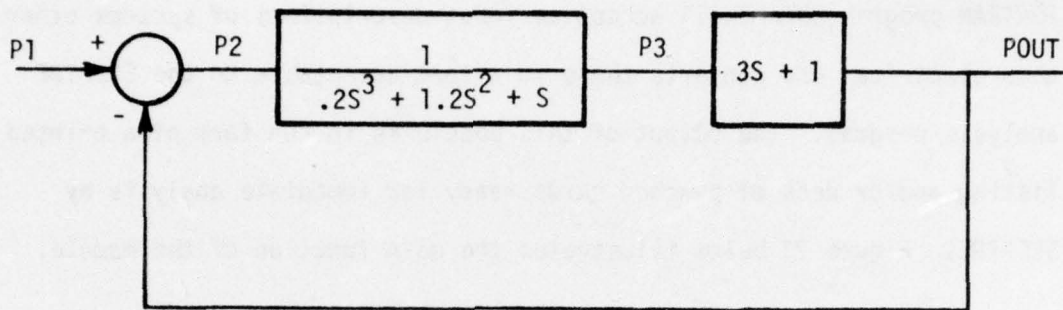

Figure 20. Unity Feedback System Example

From the input, the program derives equations at each node as follows:

$$P2 = P1 - POUT$$

$$\ddot{P}3 = (P2 - 1.2 \dot{P}3 - \dot{P}3)/.2$$

$$POUT = 3\dot{P}3 + P3$$

These equations are then broken down to first order equations if necessary as shown in Equation set (41) and the proper variable substitutions made.

The generated set of equations acceptable to SCEPTRE are listed below.

$$\left. \begin{aligned}
 P2 &= P1 - POUT \\
 \dot{P}3 &= \ddot{P}3A \\
 \dot{P}3A &= \ddot{P}3 = P3B \\
 P3B &= P3 = (P2 - 1.2 P3B - P3A)/.2 \\
 POUT &= 3 P3A + P3
 \end{aligned} \right\} \quad (41)$$

The extra parameters generated by NELSIM (P3A and P3B) are unique variables whose names are generated from the original parameter name (i.e., P3).

SECTION V
PROGRAM CONFIGURATION

The NonElectrical Languages Simulation Module consists of a FORTRAN program which will accept as input descriptions of systems other than electrical and converts these to a form acceptable to the SCEPTRE analysis program. The output of this module is in the form of a printed listing and/or deck of punched cards ready for immediate analysis by SCEPTRE. Figure 21 below illustrates the main function of the module.

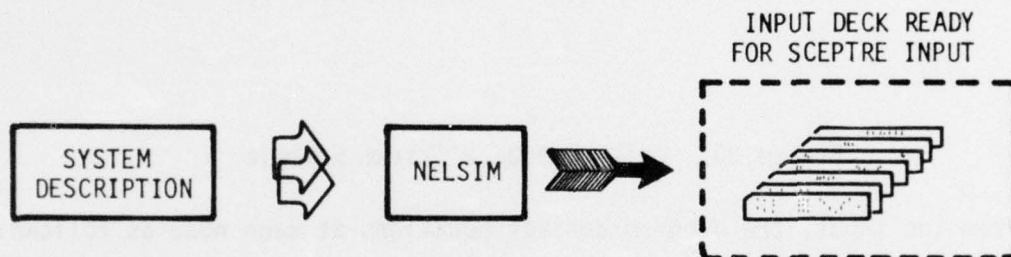

Figure 21. Main Function of Non-Electrical Languages Simulation Module

The input language of NELSIM is format free and user oriented with a syntax similar to that of SCEPTRE. The input types allowed for NELSIM are illustrated in Figure 2 and discussed in Sections II through IV. This section documents the configuration of the program and subroutines utilized to perform the functions described in the past sections.

The program is made up of three modules, an input processor, translator and output processor. The input processor reads in the input data, determines the type of translation needed, and stores and prepares the information for the translator. The translator performs all necessary transformation calculations and scaling. It then stores the information in a manner easily accesible to the output processor.

3

The output processor accesses the information stored by the system translator and outputs it in a format compatible with the SCEPTRE input languages. The information can be punched on cards at the option of the user. The input is allowed in terms of combinations of blocks containing either differential equations, transfer functions or functional elements of the various disciplines coupled by nodal connections or algebraic equations. The program translator treats each block individually performing the appropriate conversion and then connects them as defined by the user. A flow chart of the main functions of the program is provided in Figure 22.

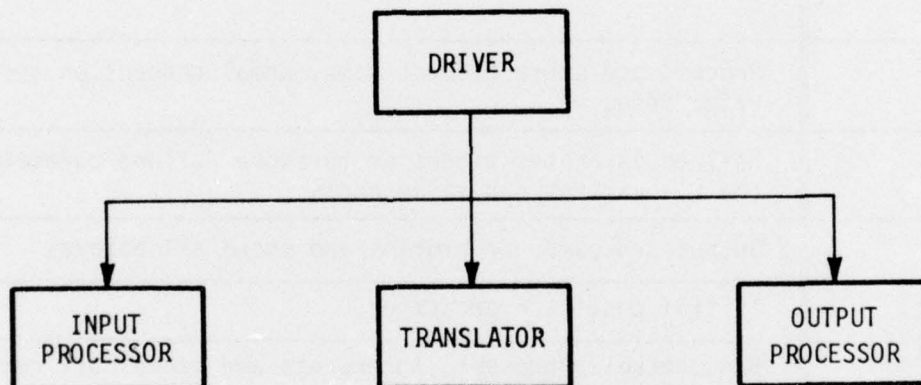

Figure 22. NELSIM Major Functions

The translated output from NELSIM is configured to produce information of a form that can be used directly as input into SCEPTRE. In order to allow alteration of the output format for use with other programs, the routines that require change have been placed in the output processor module and have been given subprogram names that end in "OUT". These routines are: ELOUT, DPOUT, RCOUT, ICOUT, and MODOUT. A description of these routines is contained in Table X.

Only the main subroutines and major flow of the program have been illustrated. Table X below contains a list of these subroutines and their particular functions. A complete list of all subroutines utilized by NELSIM is provided in Table X.

Table X. Major NELSIM Routines and Functions

ROUTINE NAME	FUNCTIONS
DRIVER	Main program, controls entire execution of program and contains calls to all modules
GTCRD	Get a card and determine heading or subheading type
ELMSET DPSET MODSET OUTSET ICSET	Determine starting locations of elements, defined parameters, models, output and set initial conditions of variables for each system entered
ELMPRS	Process and store element name, nodal connection and value codes
DPPRS	Defined parameter processor to store defined parameters, their locations and value codes
OUTPRS	Output processor to process and store all outputs
ICPRS	Initial condition processor
RCPRS	Run control processor, interprets and stores all run controls information
FNPRS	Function processor, processes and outputs all tabual or data as well as equation data
DET	Driver for differential equation translator
TFT	Driver for transfer function translator
SNODES	Reorder and rename nodal connections as necessary
CHANGE	Translate mechanical elements to electrical analogs
TCHANGE	Translate thermal elements to electrical analogs
ELOUT	Output all elements under the 'Elements' subheading
ELWRITE	Write out elements and values onto temporary tape prior to final output by DRIVER.

Table X. Major NELSIM Routines and Functions - Continued

ROUTINE NAME	FUNCTIONS
EQFCHG	Change contents of equation, function or expression from user provided quantities to electrical analog quantities
DPOUT	Output defined parameters under 'DEFINED PARAMETERS' subheading
DPWRITE	Write out defined parameters onto temporary tape prior to final output by DRIVER
RCOUT	Output all run control information
ICOUT	Output all initial conditions
OUTPTO	Output all outputs of system
OUTWRIT	Write outputs on temporary tape prior to final output by DRIVER
SCALE	Scale element values to units provided by user
MODFUNC	Write out functions necessary for models used
MODOUT	Driver to output models desired in defined parameter format
GYRO	Subroutine containing first order differential equations describing the gyro built in model
MODWRIT	Write model information on temporary tape prior to actual output by DRIVER
ACCEL	subroutines containing first order differential equations necessary to describe the built in accelerometer model

Each module is discussed in detail in the next paragraphs.

Figure 23 illustrates the flow of the input processor. The functional subheading processor is shown in Figure 24 and stores all the information regarding the functional subheading, for example ELMPRS stores all element related information such as element type, nodal connections and element value.

The major subroutines utilized by the analog translator are shown in Figure 25. These subroutines generate electrical analogs from input thermal, mechanical, electro-mechanical and electro-optical system descriptions as defined in Section II.

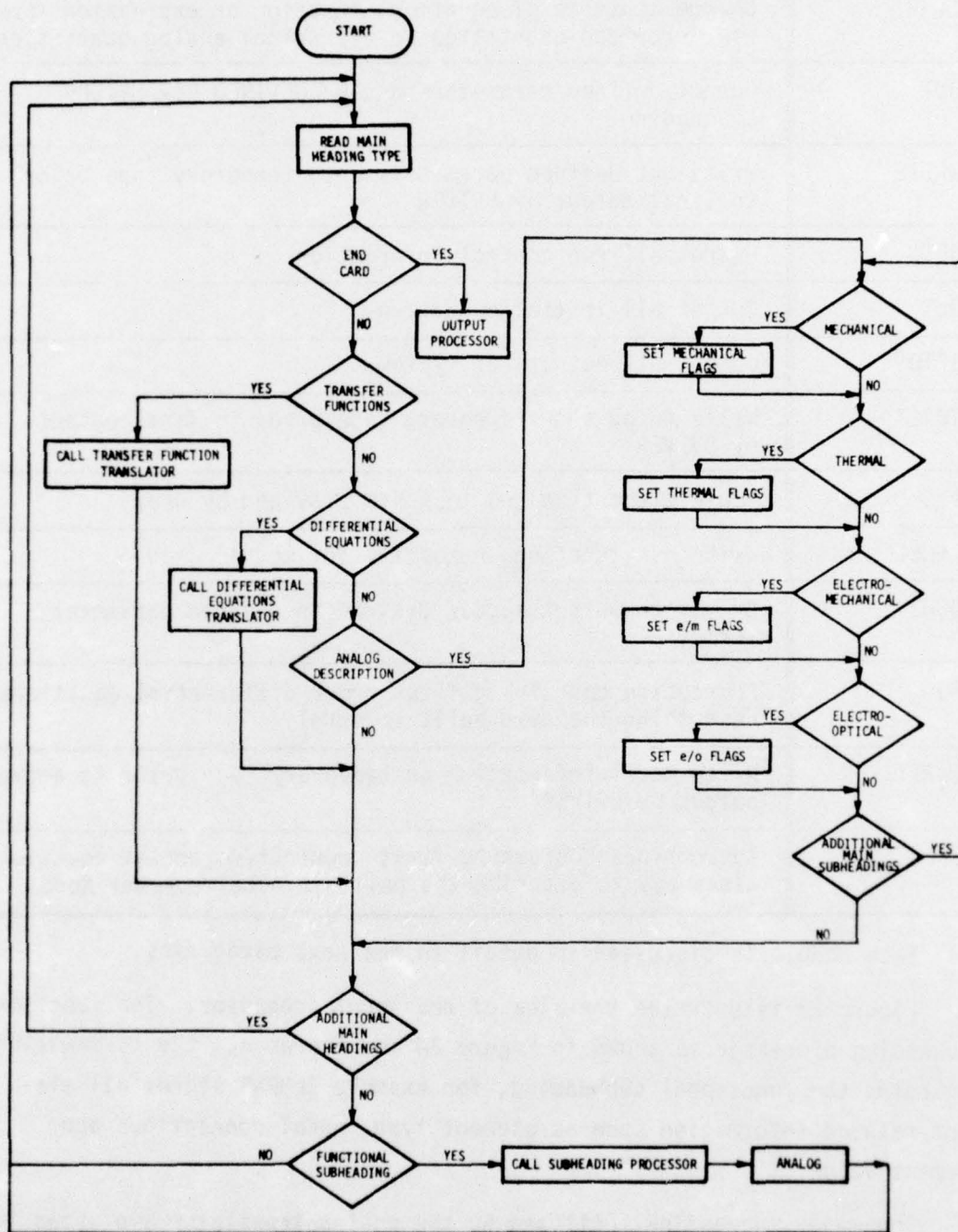

Figure 23. NELSIM Input Processor

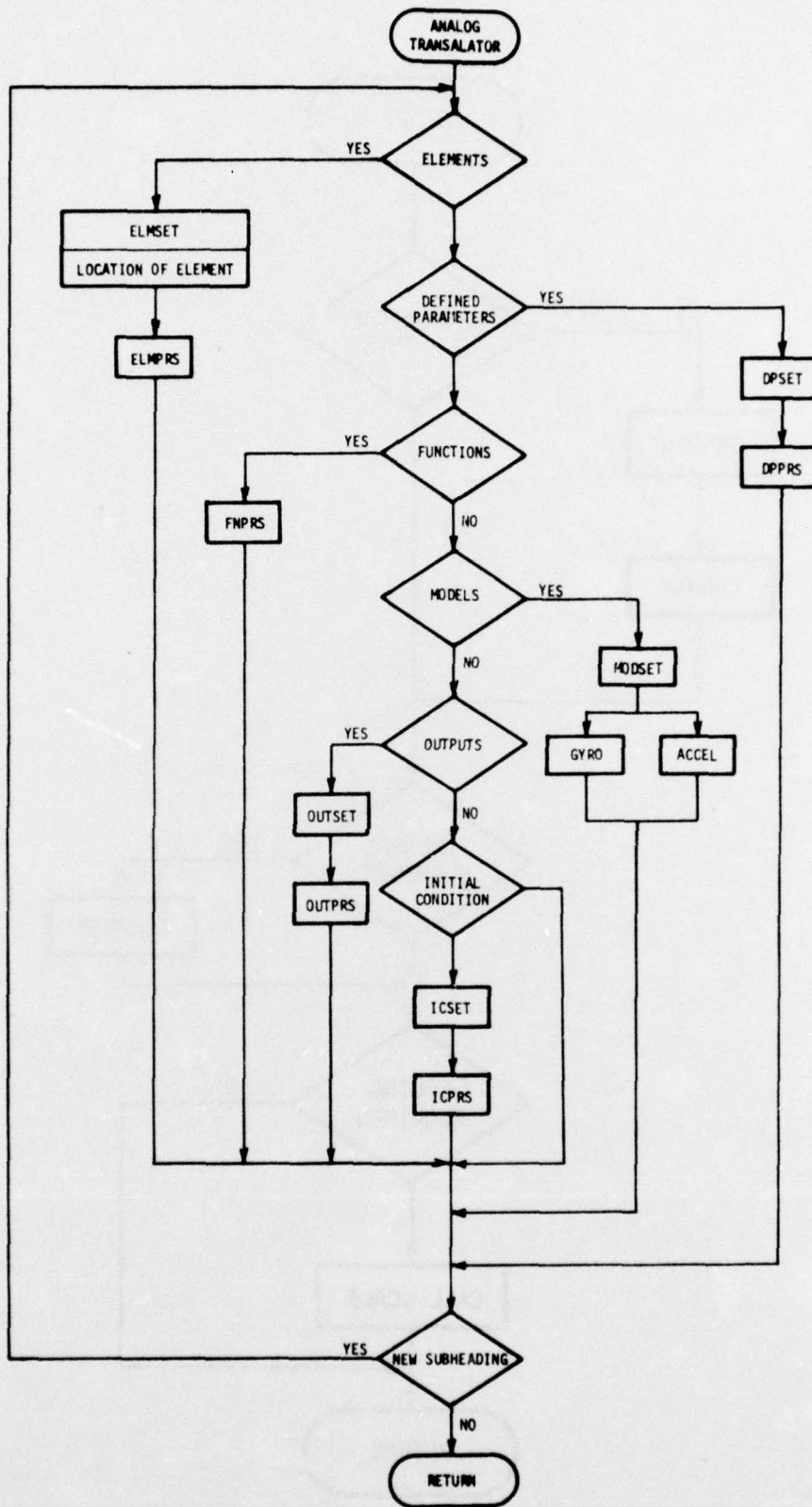

Figure 24. Function Subheading Processor

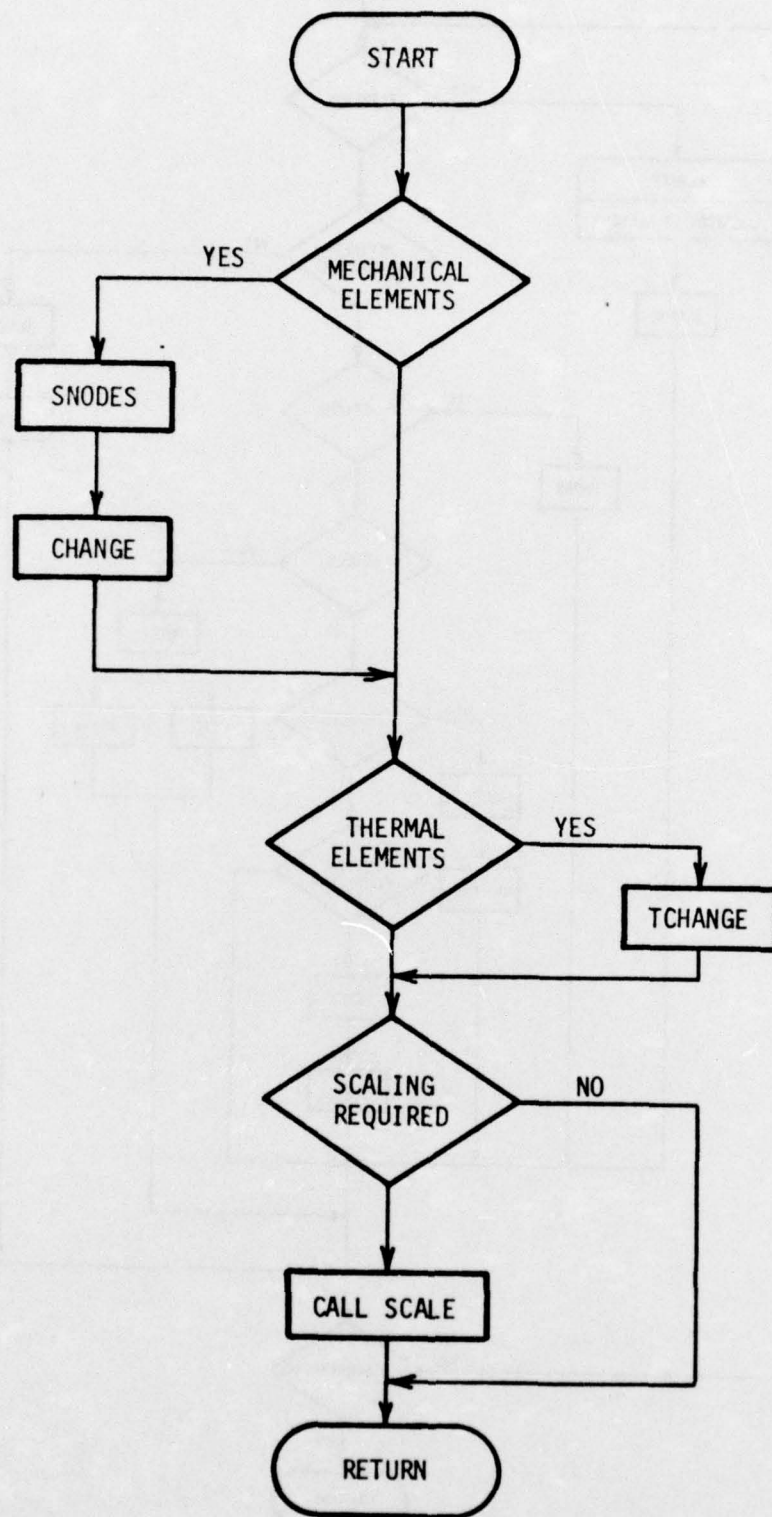

Figure 25. Translator Main Routines

When differential equations are entered the program calls on the Differential Equation Translator (DET) which performs the functions documented in Section III. The functional flow of the DET module is as follows:

1. Locate all delimiters within equation.
2. Break equation into major parts.
3. Isolate parts containing derivative terms on left side of equal sign and algebraically move remaining terms to right of equal sign.
4. Isolate highest derivative term and algebraically move remaining derivative terms to right of equal sign.
5. Isolate highest derivative term from its coefficient, moving coefficient algebraically to right side of the equation.
6. Examine highest derivative order and convert N^{th} order equation to N^{1st} order equations.

Figure 26 depicts the flow for a sample equation.

The Transfer Function Translator (TFT) is utilized when a set of transfer functions are input into the program. The TFT generates the set of first order differential equations depicting the system. The flow of the TFT module is illustrated in Figure 27.

The output processor is illustrated in Figure 28. The functions such as tables and equations are output by the program first, then all the elements are output followed by all the defined parameters. The requested outputs are then written out. Output of initial conditions, run control information and rerun description finishes the output function. The two output options are then executed, namely if the punch option is requested, the deck is punched and if the scale option is requested, the scaled output is listed out.

D I F F E R E N T I A L E Q U A T I O N T R A N S L A T O R

1. GIVEN THE FOLLOWING EQUATION

$$B*(D1V3-D1V2) + K2*(V3-V2) + M3*D2V3 + K3*V3 = F1*T1$$

2. COMPRESSING OUT ALL BLANKS YIELDS

$$+B*(D1V3-D1V2) + K2*(V3-V2) + M3*D2V3 + K3*V3 = F1*T1$$

3. BREAKING THE EQUATION INTO PARTS YIELDS

$$\begin{aligned} &+B*(D1V3-D1V2) \\ &+K2*(V3-V2) \\ &+M3*D2V3 \\ &+K3*V3 \\ &=F1*T1 \end{aligned}$$

4. REARRANGING THE PARTS YIELDS

$$\begin{aligned} &+B*(D1V3-D1V2) \\ &+M3*D2V3 \\ &=F1*T1 \quad -K2*(V3-V2) \quad -K3*V3 \end{aligned}$$

5. ISOLATING ONLY THE HIGHEST DERIVATIVE YIELDS

$$\begin{aligned} &+M3*D2V3 \\ &=F1*T1 \quad -K2*(V3-V2) \quad -K3*V3 \quad -B*(D1V3-D1V2) \end{aligned}$$

6. SEPARATING THE DERIVATIVE TERM AND
COMPRESSING OUT THE BLANKS YIELDS

$$D2V3 = (F1*T1 - K2*(V3-V2) - K3*V3 - B*(D1V3-D1V2)) / M3$$

7. TRANSFORMING THE EQUATION YIELDS

$$\begin{aligned} DPV3A &= (PF1*PT1 - PK2*(PV3-PV2) - PK3*PV3 - PB*(PV3A-PV2A)) / PM3 \\ DPV3 &= PV3A \end{aligned}$$

Figure 26. DET Functional Flow

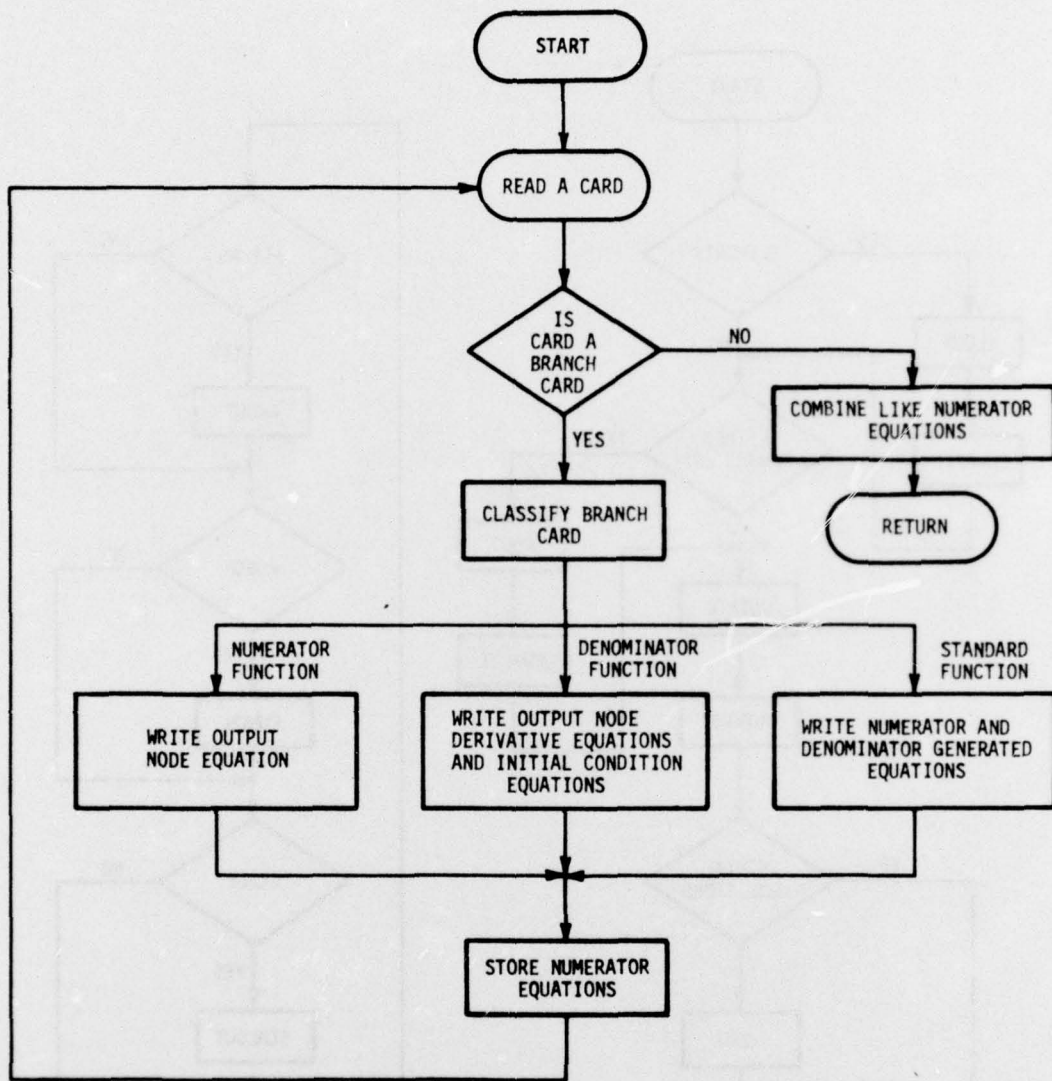

Figure 27. Transfer Function Translator Functional Flow

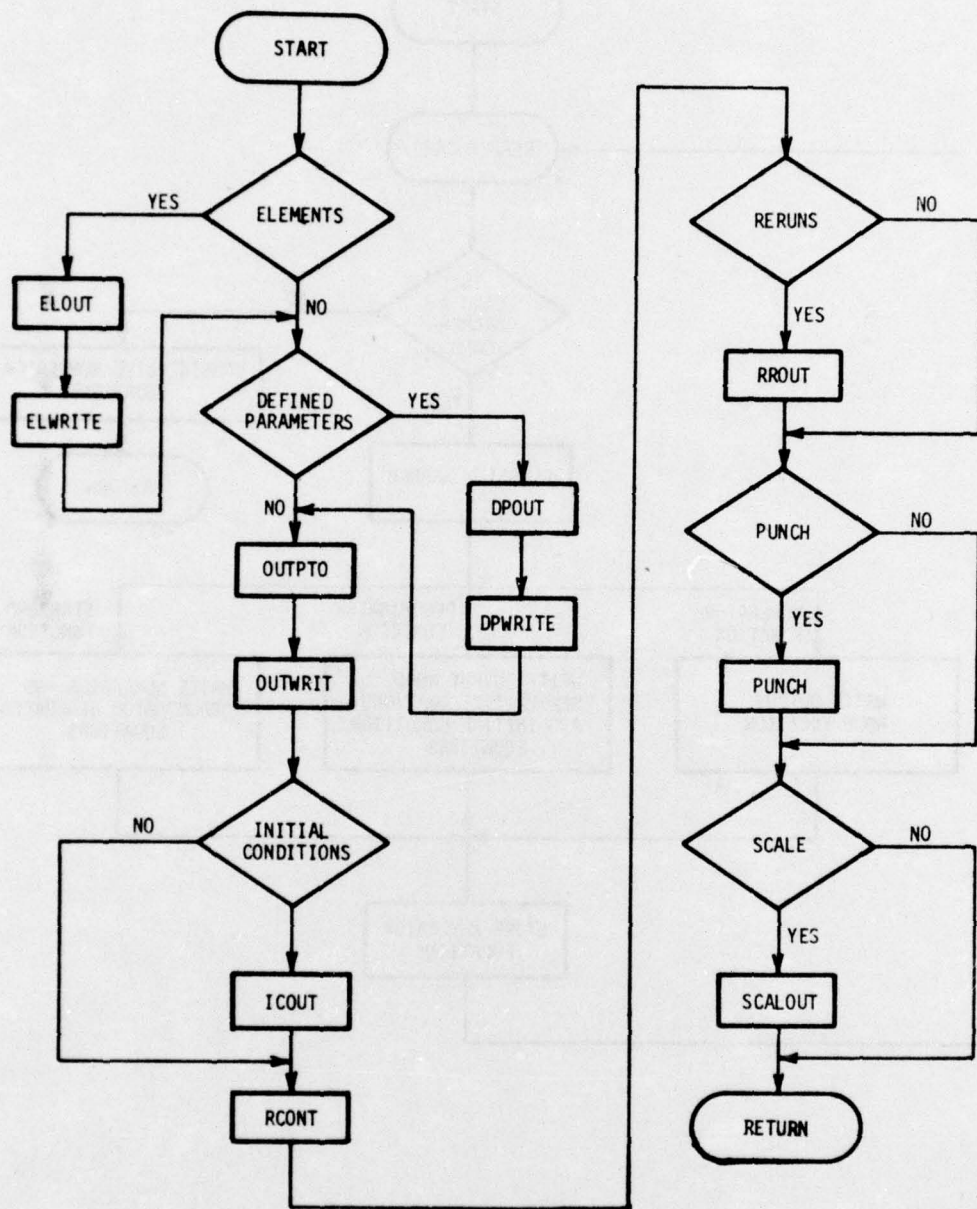

Figure 28. Output Processor Routines

DISTRIBUTION LIST

DEPARTMENT OF DEFENSE

Director
Armed Forces Radiobiology Research Institute
Defense Nuclear Agency
ATTN: Robert E. Carter
ATTN: Tech. Lib.

Director
Defense Communications Agency
ATTN: Code 540.5
ATTN: Code 930, Monte I. Burgett, Jr.

Defense Documentation Center
12 cy ATTN: TC

Director
Defense Nuclear Agency
ATTN: DDST
ATTN: STSI
3 cy ATTN: STTL, Tech. Lib.

Headquarters
European Command
J-5
ATTN: ECJ6-PF

AUL
ATTN: LDE

Commander
Field Command
Defense Nuclear Agency
ATTN: FCPR

Chief
Livermore Division, Field Command, DNA
ATTN: FCPRL

OJCS/J-3
ATTN: J-3, RDTA Br., WWMCCS, Plans Div.

DEPARTMENT OF THE ARMY

Commander
Frankford Arsenal
ATTN: SARFA-FCD, Marvin Elnick

Commander
Harry Diamond Laboratories
ATTN: AMXDO-EM, R. Bostak
ATTN: AMXDO-RB, Joseph R. Miletta
ATTN: AMXDO-RBI, John A. Rosado
ATTN: AMXDO-RCC, John E. Thompkins
ATTN: AMXDO-EM, Robert F. Gray
ATTN: AMXDO-EM, Raphael Wong
ATTN: AMXDO-RC, Robert B. Oswald, Jr.
ATTN: AMXDO-EM, J. W. Beilfuss

Commander
Picatinny Arsenal
ATTN: SMUPA-FR-S-P, Lester W. Doremus
ATTN: SARPA-ND-N
ATTN: SARPA-ND-C-E, Amina Nordio

Commander
TRASANA
ATTN: ATAA-EAC, Francis N. Winans

DEPARTMENT OF THE ARMY (Continued)

Director
U. S. Army Ballistic Research Labs.
ATTN: AMXBR-X, Julius J. Meszaros
ATTN: AMXBR-VL, John W. Kinch
ATTN: AMXRD-BVL, David L. Rigotti

Commander
U. S. Army Electronics Command
ATTN: AMSEL-GG-TD, W. R. Werk
ATTN: AMSEL-TL-MD, Gerhart K. Gaule
ATTN: AMSEL-TL-IR, Edwin T. Hunter

Commanding Officer
U. S. Army Electronics Command
ATTN: CPT Allan S. Parker

Commander
U. S. Army Electronics Proving Ground
ATTN: STEEP-MT-M, Gerald W. Durbin

Commandant
U. S. Army Field Artillery School
ATTN: ATSFA-CTD-ME, Harley Moberg

Commander
U. S. Army Mat. & Mechanics Rsch. Ctr.
ATTN: AMXMR-HH, John F. Dignam

Commander
U. S. Army Materiel Dev. & Readiness Cmd.
ATTN: AMCRD-WN-RE, John F. Corrigan

Commander
U. S. Army Missile Command
ATTN: AMSI-RGP, Victor W. Ruwe
ATTN: AMSMI-RGP, Hugh Green
ATTN: AMSMI-RRR, Faison P. Gibson

Commander
U. S. Army Nuclear Agency
ATTN: ATCN-W, LTC Leonard A. Sluga

Project Manager
U. S. Army Tactical Data Systems, AMC
ATTN: Dwaine B. Huewe

Commander
White Sands Missile Range
ATTN: STEWS-TE-NT, Marvin P. Squires

DEPARTMENT OF THE NAVY

Chief of Naval Research
Navy Department
ATTN: Code 427

Commanding Officer
Naval Ammunition Depot
ATTN: Code 7024, James Ramsey

Commander
Naval Electronic Systems Command
ATTN: ELEX 05323, Cleveland F. Watkins
ATTN: PME 117-21
ATTN: Code 50451

DEPARTMENT OF THE NAVY (Continued)

Commander
Naval Electronics Laboratory Center
ATTN: H. F. Wong

Director
Naval Research Laboratory
ATTN: Code 2627, Doris R. Folen

Commander
Naval Surface Weapons Center
ATTN: Code 431, Edwin B. Dean
ATTN: Code WX21, Tech. Lib.

Commander
Naval Surface Weapons Center
ATTN: Code FUR, Robert A. Amadori

Commanding Officer
Naval Weapons Evaluation Facility
ATTN: Code ATG, Mr. Stanley

Director
Strategic Systems Project Office
ATTN: SP-2701, John W. Pitsenberger

DEPARTMENT OF THE AIR FORCE

Commander
Aeronautical Systems Division, AFSC
ATTN: ASD-YH-EX, Lt Col Robert Leverette

AF Aero-Propulsion Laboratory, AFSC
ATTN: POD, P. E. Stover

AF Weapons Laboratory, AFSC
ATTN: ELA
ATTN: ELC
ATTN: ELP, Carl E. Baum
ATTN: HO
2 cy ATTN: SUL

AFTAC
ATTN: TAF

Air Force Avionics Laboratory, AFSC
ATTN: AFAL, TEA, Hans J. Hennecke
ATTN: AFAL, AAA

Commander
Foreign Technology Division, AFSC
ATTN: FTD, PDJC

Commander
Ogden Air Logistics Center
ATTN: MMEWM, Robert Joffs

SAMSO/DY
ATTN: DYS, Maj Larry A. Darda

SAMSO/YD
ATTN: YDD, Maj Marion P. Schneider

Commander in Chief
Strategic Air Command
ATTN: XPFS, Maj Brian G. Stephan

ENERGY RESEARCH & DEVELOPMENT ADMINISTRATION

Los Alamos Scientific Laboratory
ATTN: Doc. Con. for Bruce W. Noel
ATTN: Doc. Con. for J. Arthur Freed

ENERGY RESEARCH & DEVELOPMENT ADMINISTRATION
(Continued)

University of California
Lawrence Livermore Laboratory
ATTN: Donald J. Meeker, L-153
ATTN: E. K. Miller, L-156
ATTN: Lawrence Cleland, L-156
ATTN: Frederick R. Kovar, L-94
ATTN: William J. Hogan, L-531

DEPARTMENT OF DEFENSE CONTRACTORS

Aerojet Electro-Systems Co. Div.
Aerojet-General Corporation
ATTN: Thomas D. Hanscome

Aeronutronic Ford Corporation
Aerospace & Communications Ops.
ATTN: E. R. Poncelet, Jr.
ATTN: Ken C. Attinger
ATTN: Tech. Info. Section

Aeronutronic Ford Corporation
Western Development Laboratories Div.
ATTN: Samuel R. Crawford, M.S. 531

Avco Research & Systems Group
ATTN: Research Library, A-830, Rm. 7201

The BDM Corporation
ATTN: T. H. Neighbors
ATTN: William Druen

Bell Aerospace Company
Division of Textron, Inc.
ATTN: Carl B. Schoch, Wpns. Effects Grp.

The Bendix Corporation
Communication Division
ATTN: Doc. Con.

The Bendix Corporation
Research Laboratories Division
ATTN: Donald J. Niehaus, Mgr. Prgm.

The Boeing Company
ATTN: Robert S. Caldwell, M.S. 2R-00
ATTN: Donald W. Egelkrodt, M.S. 2R-00
ATTN: David L. Dye, M.S. 87-75
ATTN: Aerospace Library
ATTN: Howard W. Wicklein, M.S. 17-11

Booz-Allen & Hamilton, Inc.
ATTN: Raymond J. Chrisner

Brown Engineering Company, Inc.
ATTN: David L. Lambert, M.S. 18

Charles Stark Draper Laboratory, Inc.
ATTN: Kenneth Fertig
ATTN: Paul R. Kelly

Computer Sciences Corporation
ATTN: Richard H. Dickhaut

Cutler-Hammer, Inc.
AIL Division
ATTN: Anne Anthony, Central Tech. Files

DEPARTMENT OF DEFENSE CONTRACTORS (Continued)

University of Denver
Colorado Seminary
ATTN: Sec. Officer for Fred P. Venditti

The Dikewood Corporation
ATTN: L. Wayne Davis

E-Systems, Inc.
Greenville Division
ATTN: Library, 8-50100

Exp. & Math. Physics Consultants
ATTN: Thomas M. Jordan

Fairchild Industries, Inc.
ATTN: Mgr., Config. Data & Standards

The Franklin Institute
ATTN: Ramie H. Thompson

Garrett Corporation
ATTN: Robert E. Weir, Dept. 93-9

General Electric Company
Space Division
ATTN: Larry I. Chasen
ATTN: John R. Greenbaum
ATTN: Joseph C. Peden, CCF 8301
ATTN: John L. Andrews
ATTN: James P. Spratt

General Electric Company
Re-Entry & Environmental Systems Div.
ATTN: Robert V. Benedict

General Electric Company
TEMPO-Center for Advanced Studies
ATTN: DASIAC
ATTN: William McNamera
ATTN: Royden R. Rutherford
ATTN: M. Espig

General Electric Company
ATTN: CSP 0-7, L. H. Dee

General Electric Company
Aerospace Electronics Systems
ATTN: W. J. Patterson, Drop 233
ATTN: George Francis, Drop 233

General Electric Company-TEMPO
ATTN: DASIAC for William Alfonte

General Research Corporation
ATTN: Robert D. Hill

General Research Corporation
Washington Operations
ATTN: David K. Osias

GTE Sylvania, Inc.
Electronics Systems Grp.-Eastern Div.
ATTN: Leonard L. Blaisdell
ATTN: James A. Waldon

GTE Sylvania, Inc.
ATTN: Charles H. Ramsbottom
ATTN: Herbert A. Ullman
ATTN: David P. Flood

DEPARTMENT OF DEFENSE CONTRACTORS (Continued)

Gulton Industries, Inc.
Engineered Magnetics Division
ATTN: Eng. Magnetics Div.

Harris Corporation
Harris Semiconductor Division
ATTN: T. L. Clark, M.S. 4040
ATTN: Wayne E. Abare, M.S. 16-111
ATTN: Carl F. Davis, M.S. 17-220

Hazeltine Corporation
ATTN: M. Waite, Tech. Info. Ctr.

Honeywell, Incorporated
Government & Aeronautical Products Division
ATTN: Ronald R. Johnson, A-1622

Honeywell, Incorporated
Aerospace Division
ATTN: Stacey H. Graff, M.S. 725-J
ATTN: James D. Allen, M.S. 775-D
ATTN: Harrison H. Noble, M.S. 725-5A

Honeywell, Incorporated
ATTN: Tech. Lib.

Hughes Aircraft Company
ATTN: Billy W. Campbell, M.S. 6-E-110
ATTN: Kenneth R. Walker, M.S. D-157

Hughes Aircraft Company
Space Systems Division
ATTN: William W. Scott, M.S. A-1080
ATTN: Edward C. Smith, M.S. A-620

IBM Corporation
ATTN: Frank Frankovsky
ATTN: Harry W. Mathers, Dept. M-41

IIT Research Institute
ATTN: Irving N. Mindel

Intelcom Rad Tech
ATTN: R. L. Mertz
ATTN: Leo D. Cotter
ATTN: Eric P. Wenaas
ATTN: MDC

Kaman Sciences Corporation
ATTN: John R. Hoffman
ATTN: Albert P. Bridges
ATTN: Donald H. Bryce
ATTN: W. Foster Rich
ATTN: Walter E. Ware

Litton Systems, Inc.
Guidance & Control Systems Division
ATTN: R. W. Maughmer
ATTN: Val J. Ashby, M.S. 67

Lockheed Missiles & Space Co., Inc.
ATTN: George F. Heath, Dept. 81-14
ATTN: Benjamin T. Kimura, Dept. 81-14
ATTN: Hans L. Schneemann, Dept. 81-64

LTV Aerospace Corporation
ATTN: Technical Data Ctr.

DEPARTMENT OF DEFENSE CONTRACTORS (Continued)

Martin Marietta Aerospace
Orlando Division
ATTN: Jack M. Ashford, MP-537
ATTN: Mona C. Griffith, Library, MP-30
ATTN: William W. Mras, MP-413

Martin Marietta Corporation
Denver Division
ATTN: J. E. Goodwin, Mail 0452
ATTN: Paul G. Kase, Mail 8203

McDonnell Douglas Corporation
ATTN: Tom Ender
ATTN: Tech. Lib.

McDonnell Douglas Corporation
ATTN: Stanley Schneider
ATTN: Raymond J. DeBattista

McDonnell Douglas Corporation
ATTN: Tech. Lib., C1-290/36-84

Mission Research Corporation
ATTN: William C. Hart

Mission Research Corporation
ATTN: J. Roger Hill
ATTN: David E. Merewether

The Mitre Corporation
ATTN: M. E. Fitzgerald

National Academy of Sciences
ATTN: National Materials Advisory Board, for
R. S. Shane, Nat. Materials Advsy.

Northrop Corporation
Electronic Division
ATTN: Boyce T. Ahlport
ATTN: George H. Towner
ATTN: Vincent R. DeMartino

Northrop Corporation
ATTN: Orlie L. Curtis, Jr.
ATTN: James P. Raymond
ATTN: David N. Pocock

Northrop Corporation
Electronic Division
ATTN: Joseph D. Russo

Physics International Company
ATTN: Doc. Con. for John H. Huntington

R & D Associates
ATTN: S. Clay Rogers
ATTN: Leonard Schlessinger

The Rand Corporation
ATTN: Cullen Crain

Raytheon Company
ATTN: Gajanan H. Joshi, Radar Sys. Lab.

Raytheon Company
ATTN: James R. Weckback
ATTN: Harold L. Flescher

DEPARTMENT OF DEFENSE CONTRACTORS (Continued)

RCA Corporation
Government & Commercial Systems
ATTN: George J. Brucker

RCA Corporation
ATTN: E. Van Keuren, 13-5-2

Rockwell International Corporation
ATTN: James E. Bell, HA-10
ATTN: George C. Messenger, FB-61

Rockwell International Corporation
Electronics Operations
ATTN: Mildred A. Blair
ATTN: Alan A. Langenfeld
ATTN: Dennis Sutherland

Sanders Associates, Inc.
ATTN: Moe L. Aitel, NCA, 1-3236

Science Applications, Inc.
ATTN: Frederick M. Tesche

Science Applications, Inc.
ATTN: William L. Chadsey

Science Applications, Inc.
ATTN: J. Robert Beyster
ATTN: Larry Scott

Science Applications, Inc.
Huntsville Division
ATTN: Noel R. Byrn

Simulation Physics, Inc.
ATTN: John R. Uglum

The Singer Company
ATTN: Irwin Goldman, Eng. Management

Sperry Flight Systems Division
Sperry Rand Corporation
ATTN: D. Andrew Schow

Sperry Rand Corporation
Sperry Division
ATTN: Paul Marraffino

Stanford Research Institute
ATTN: Philip J. Dolan
ATTN: Arthur Lee Whitson

Sundstrand Corporation
ATTN: Curtis B. White

Systron-Donner Corporation
ATTN: Gordon B. Dean

Texas Instruments, Inc.
ATTN: Gary F. Hanson
ATTN: Donald J. Manus, M.S. 72

Texas Tech. University
ATTN: Travis L. Simpson

DEPARTMENT OF DEFENSE CONTRACTORS (Continued)

TRW Systems Group

ATTN: A. M. Liebschutz, R1-1162
ATTN: Richard H. Kingsland, R1-2154
ATTN: A. A. Witteles, R1-1120
ATTN: Aaron H. Narevsky, R1-2144
ATTN: Benjamin Sasgholtz
ATTN: Lillian D. Singletary, R1-1070
ATTN: Jerry I. Lubell
ATTN: M. Epstein
ATTN: J. R. Pistacchi

TRW Systems Group

San Bernardino Operations
ATTN: John E. Dahnke
ATTN: H. S. Jensen

DEPARTMENT OF DEFENSE CONTRACTORS (Continued)

United Technologies Corporation
Hamilton Standard Division
ATTN: Raymond G. Giguere

Victor A. J. Van Lint, Consultant
Mission Research Corporation
ATTN: V. A. J. Van Lint

Westinghouse Electric Corporation
ATTN: Henry P. Kalapaca, M. S. 3525

Official Record Copy (P.O.)