

AD-A033 631

PRC INFORMATION SCIENCES CO MCLEAN VA
USER'S MANUAL FOR THE REFERENCE SCENE SOFTWARE (RSS). (U)
OCT 76 S H MORITZ

F/G 8/2

DAAK02-75-C-0098

UNCLASSIFIED

PRC-R-1938

ETL-0066

NL

1 OF 1
AD-A
033 631

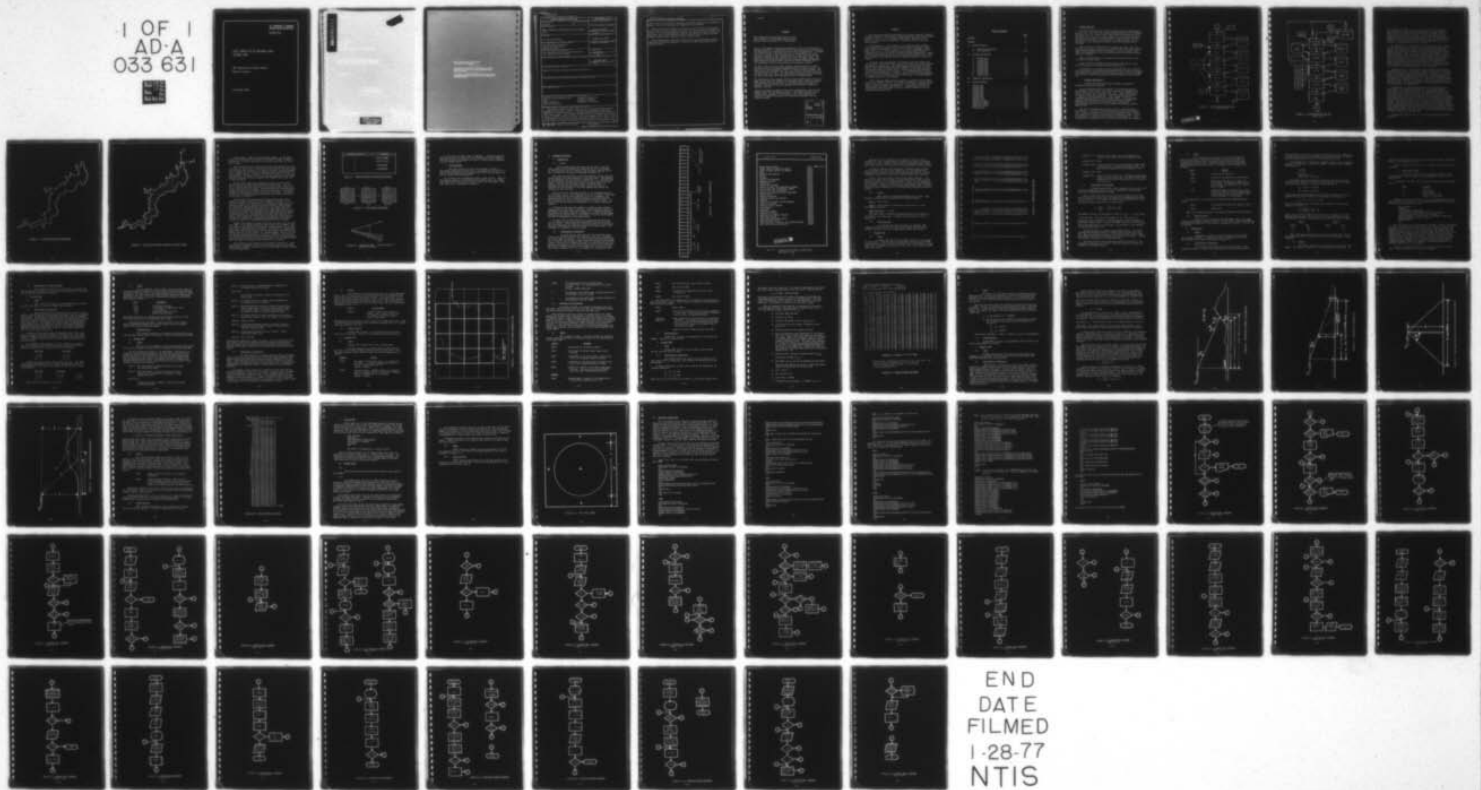

END
DATE
FILMED
1-28-77
NTIS

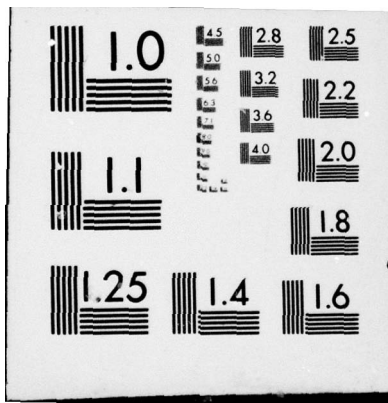

**U.S. DEPARTMENT OF COMMERCE
National Technical Information Service**

AD-A033 631

USER'S MANUAL FOR THE REFERENCE SCENE
SOFTWARE (RSS)

PRC INFORMATION SCIENCES COMPANY
MCLEAN, VIRGINIA

15 OCTOBER 1976

Destroy this report when no longer needed.
Do not return it to the originator.

The findings in this report are not to be construed as an official
Department of the Army position unless so designated by other
authorized documents.

The citation in this report of trade names of commercially available
products does not constitute official endorsement or approval of the
use of such products.

UNCLASSIFIED

SECURITY CLASSIFICATION OF THIS PAGE (When Data Entered)

REPORT DOCUMENTATION PAGE		READ INSTRUCTIONS BEFORE COMPLETING FORM								
1. REPORT NUMBER ETL-0066	2. GOVT ACCESSION NO.	3. RECIPIENT'S CATALOG NUMBER								
4. TITLE (and Subtitle) USER'S MANUAL FOR THE REFERENCE SCENE SOFTWARE (RSS)		5. TYPE OF REPORT & PERIOD COVERED Contract Report								
		6. PERFORMING ORG. REPORT NUMBER R-1938								
7. AUTHOR(s) Dr. Steven H. Moritz		B. CONTRACT OR GRANT NUMBER(s) DAAK02-75-C-0098								
		10. PROGRAM ELEMENT, PROJECT, TASK AREA & WORK UNIT NUMBERS								
9. PERFORMING ORGANIZATION NAME AND ADDRESS PRC Information Sciences Co. 7600 Old Springhouse Rd. McLean, VA 22101		12. REPORT DATE 15 Oct 76								
11. CONTROLLING OFFICE NAME AND ADDRESS U.S. Army Engineer Topographic Laboratories Fort Belvoir, Virginia 22060										
14. MONITORING AGENCY NAME & ADDRESS (if different from Controlling Office)		13. NUMBER OF PAGES 77								
		15. SECURITY CLASS. (of this report) UNCLASSIFIED								
		15a. DECLASSIFICATION/DOWNGRADING SCHEDULE								
16. DISTRIBUTION STATEMENT (of this Report) Approved for public release; distribution unlimited										
17. DISTRIBUTION STATEMENT (of the abstract entered in Block 20, if different from Report)										
18. SUPPLEMENTARY NOTES										
19. KEY WORDS (Continue on reverse side if necessary and identify by block number)										
<table> <tr> <td>Reference Scene Software (RSS)</td> <td>Automated Cartography</td> </tr> <tr> <td>Radar</td> <td>Terminal Guidance</td> </tr> <tr> <td>Radar Simulation</td> <td>Topographic Data Bases</td> </tr> <tr> <td>Computer Simulation</td> <td></td> </tr> </table>			Reference Scene Software (RSS)	Automated Cartography	Radar	Terminal Guidance	Radar Simulation	Topographic Data Bases	Computer Simulation	
Reference Scene Software (RSS)	Automated Cartography									
Radar	Terminal Guidance									
Radar Simulation	Topographic Data Bases									
Computer Simulation										
20. ABSTRACT (Continue on reverse side if necessary and identify by block number)										
<p>The Reference Scene Software (RSS) is a set of eleven CDC 6400 computer programs used in-house at the U.S. Army Engineer Topographic Laboratories (USAETL), Ft. Belvoir, Virginia, to produce simulated Plan Position Indicator (PPI) radar scenes. The two inputs required by RSS are a matrix array (raster format) of digital terrain elevations and a corresponding vector digitized list of planimetry features (roads, lakes, railroads, cities, rivers, etc.). The output of RSS is a raster format magnetic tape image of the circular PPI scene,</p>										

DD FORM 1 JAN 73 1473

EDITION OF 1 NOV 65 IS OBSOLETE

UNCLASSIFIED

1 a SECURITY CLASSIFICATION OF THIS PAGE (When Data Entered)

UNCLASSIFIED

SECURITY CLASSIFICATION OF THIS PAGE (When Data Entered)

which is later formatted onto 35mm film and machine compared to the actual PPI scene of the area to determine the "goodness" of correlation.

These programs were originally developed by the Naval Training Equipment Center (NTEC), Orlando, Florida, for visual flight simulation. They were converted to run on the ETL CDC 6400 computer, new input and output routines were developed, and the radar modeling algorithm was changed to produce a better machine readable rather than better human readable scene.

RSS is being used to determine the data base input requirements and the radar modeling algorithm parameters necessary for producing "correlatable" reference scenes.

il

SECURITY CLASSIFICATION OF THIS PAGE (When Data Entered)

ABSTRACT

PRC Information Sciences Company Report R-1938
User's Manual for the Reference Scene Software
Steven H. Moritz, October 1976 (Unclassified)

The U.S. Army Engineer Topographic Laboratories (ETL) at Fort Belvoir is presently engaged in a concentrated effort aimed at developing a methodology for generating radar reference scenes from raw cartographic data. A central part of this effort is the identification of the minimum set of radar attributes required in such reference scenes in order that they provide sufficient correlation when compared with actual PPI radar images. The objective of the effort described herein is the development of Reference Scene Generation Software (RSS) to be used by ETL as a research tool in the development of the final reference scene generation criteria.

The RSS is based on Digital Radar Landmass Simulation Software (DRLMS) provided by the Naval Training Equipment Center at Orlando, Florida. The first step in the development of RSS was to convert these programs to run in-house on ETL's CDC 6400. New input routines were written to permit the use of in-house data bases, and a new output routine was written to permit the radar scene output to be displayed on ETL's DICOMED plotter.

The second phase of the program involved further modifications of the programs to make them more suitable for correlation work. Among the improvements added were the capabilities to vary image resolution, size and coloring. The software was also analysed and corrected to improve its geometric accuracy.

Finally, a routine was added to permit the incorporation of the altitude layover effect into the reference scenes. This effect produces a non-uniform radial translation of the points on the radar image and its inclusion is expected to improve the correlation obtainable with the reference scenes.

ACCESSION for		
NTIS	White Section	<input checked="" type="checkbox"/>
DDC	Buff Section	<input type="checkbox"/>
UNANNOUNCED		<input type="checkbox"/>
JUSTIFICATION.....		
BY.....		
DISTRIBUTION/AVAILABILITY CODES		
Dist.	AVAIL. and/or	SPECIAL
A		

PREFACE

This work was principally performed by Dr. Steven H. Moritz, Planning Research Corporation, under Contract Number DAAK02-75-C-0098, Radar Programs Conversion, for the U.S. Army Engineer Topographic Laboratories, Fort Belvoir, Virginia, Bruce B. Zimmerman, Contracting Officer's Technical Representative.

This document is a user's manual for the Reference Scene Software (RSS) presently being used by the U.S. Army Engineer Topographic Laboratories (ETL) at Fort Belvoir, Virginia. It is not a programmer's manual. This is to say, it is not intended to provide sufficiently detailed information to enable the reader to perform software modifications. Rather, it is intended to provide the user with a basic understanding of the software structure and to provide all the information required to operate the system.

To satisfy these requirements, this document has been divided into four sections. The first of these supplies an overview of system functions and component programs while the second examines each program in greater detail. Part three provides detailed examples of actual deck structures for program operation and part four is a compilation of macro-flowcharts for each major component of the system. It is recommended that these be read in the order presented. However, Chapter III, on operating procedure will stand on its own and may be used in this fashion if an understanding of program functions is not required.

RSS is based on DRLMS software supplied by the Naval Training Equipment Center, Orlando, Florida. As the RSS is presently in an evolutionary stage, its final structure and capabilities will likely be somewhat more sophisticated than those described herein. Supplementary versions for this document should be issued to keep its content consistent with the changing software structure.

TABLE OF CONTENTS

	<u>Page</u>
ABSTRACT	i
PREFACE	iii
I. SYSTEM STRUCTURE	
1. Software Organization	1-1
2. File Structure	1-9
II. SOFTWARE DESCRIPTION	
1. Program RSS1	2-1
2. Program RSS2	2-4
3. Program RSS3	2-7
4. Program RSS5	2-10
5. Program RSS6	2-11
6. Program RSS7	2-13
7. Program RSS8	2-16
8. Program RSS9	2-19
9. Program SORT	2-27
10. Program RSS10	2-27
III. OPERATING INSTRUCTIONS	3-1
IV. MACRO-FLOWCHARTS	
Program RSS1	4-1
Program RSS2	4-5
Program RSS3	4-7
Program RSS5	4-9
Program RSS6	4-13
Program RSS7	4-15
Program RSS8	4-17
Program RSS9	4-19
Subroutine SIZE	4-21
Subroutine LAMBERT	4-22
Subroutine REFRMT	4-23
Subroutine ALTLAV	4-24
Program RSS10	4-25

I. SYSTEM STRUCTURE

The radar scene simulation process employed by this system consists of four steps. The first step entails the preprocessing of the planimetry data base. This file contains the identification and location of all of the "features" (i.e., cities, lakes, roads, etc.) on the map from which the scene is to be made. As described below, the operation of the RSS requires that such features be described in a special format, and it is the purpose of the preprocessing step to place the planimetry data in this form.

Step 2 entails a reformatting of the terrain data base. This file contains the elevation at each point on the map and is initially obtained from a modified UNAMACE terrain digitization. As will be shown, this format is incompatible with the processed planimetry data base and therefore must be altered.

Step 3 involves merging the planimetry data with the terrain data to produce the radar scene.

Step 4 involves reformatting the RSS image file so that the scene can be displayed on the DICOMED Scanner/Plotter at ETL.

We now proceed to identify the various programs and files involved in this procedure. The descriptions presented in this section are cursory; more detailed discussions will be presented in Chapter II of this document. When reading the following paragraphs reference should be made to Figure I.1.

1. Software Organization

Programs RSS1 through RSS5 may be viewed as comprising a planimetry preparation subsystem.

The raw planimetry data file contains X-Y point pairs defining the boundary of each feature along with a feature code identifying the type of feature (e.g., road, city, lake, etc.). This information is in the ETL flatbed vector digitizer format and contains pen commands in addition to the map information. RSS1 unpacks the feature information and throws away the pen command codes. It also performs certain initial processing functions to be described in Chapter II. These functions may be viewed as comprising an "enhancement" procedure made necessary by the data processing and accuracy requirements of RSS.

The input to program RSS2 consists of the X-Y pairs describing each feature. In RSS2 this data is converted to an entirely different form. Instead of defining features by X,Y coordinates of points around the perimeter, the feature is now defined by horizontal strips. This is illustrated for a typical feature in Figure I.2 and Figure I.3. First the perimeter is generated in the form of short horizontal line segments

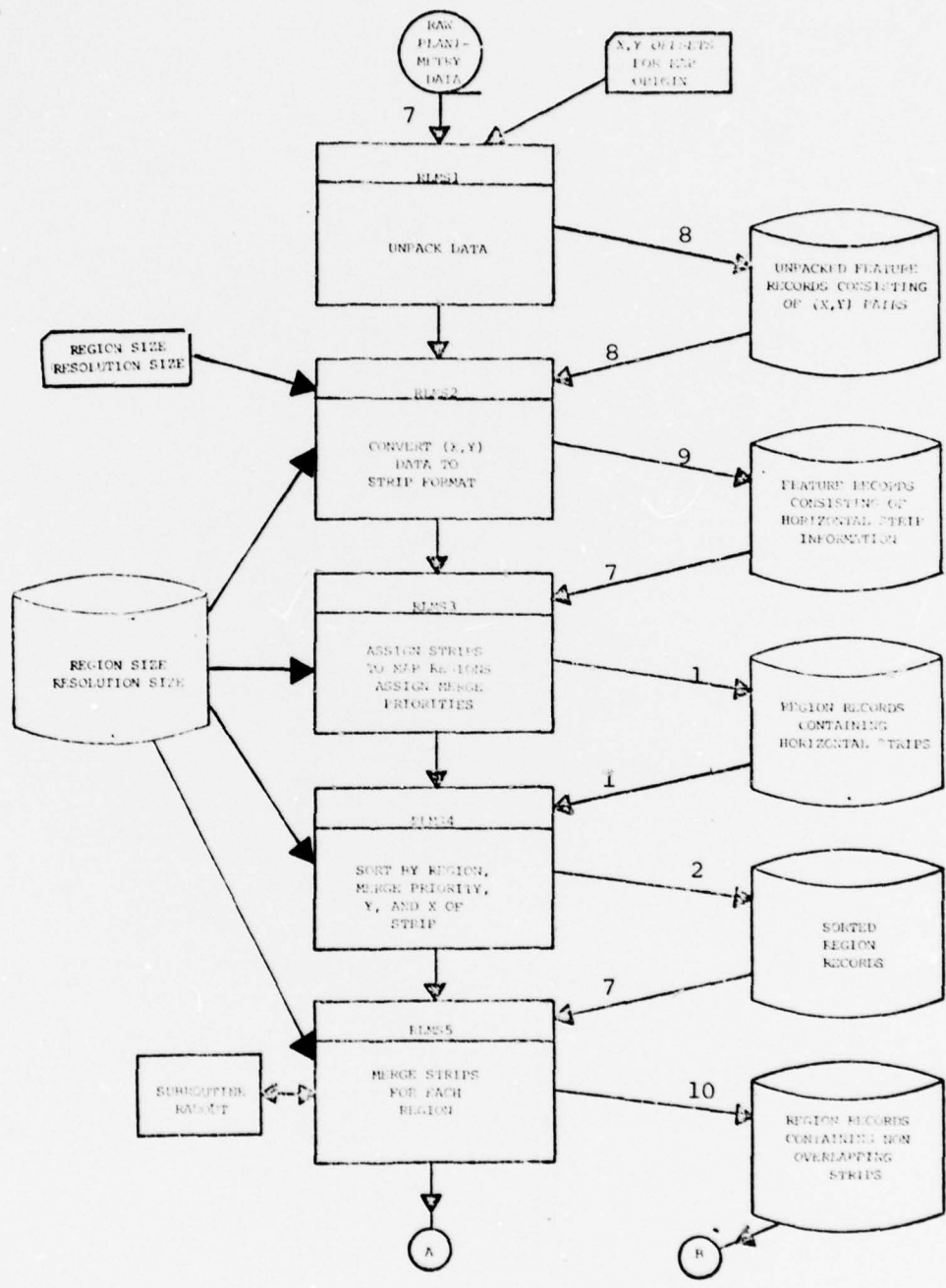

FIGURE I.1 - DRLMS PROGRAM AND DATA FLOW
(PAGE 1 OF 2)

Reproduced from best available copy.

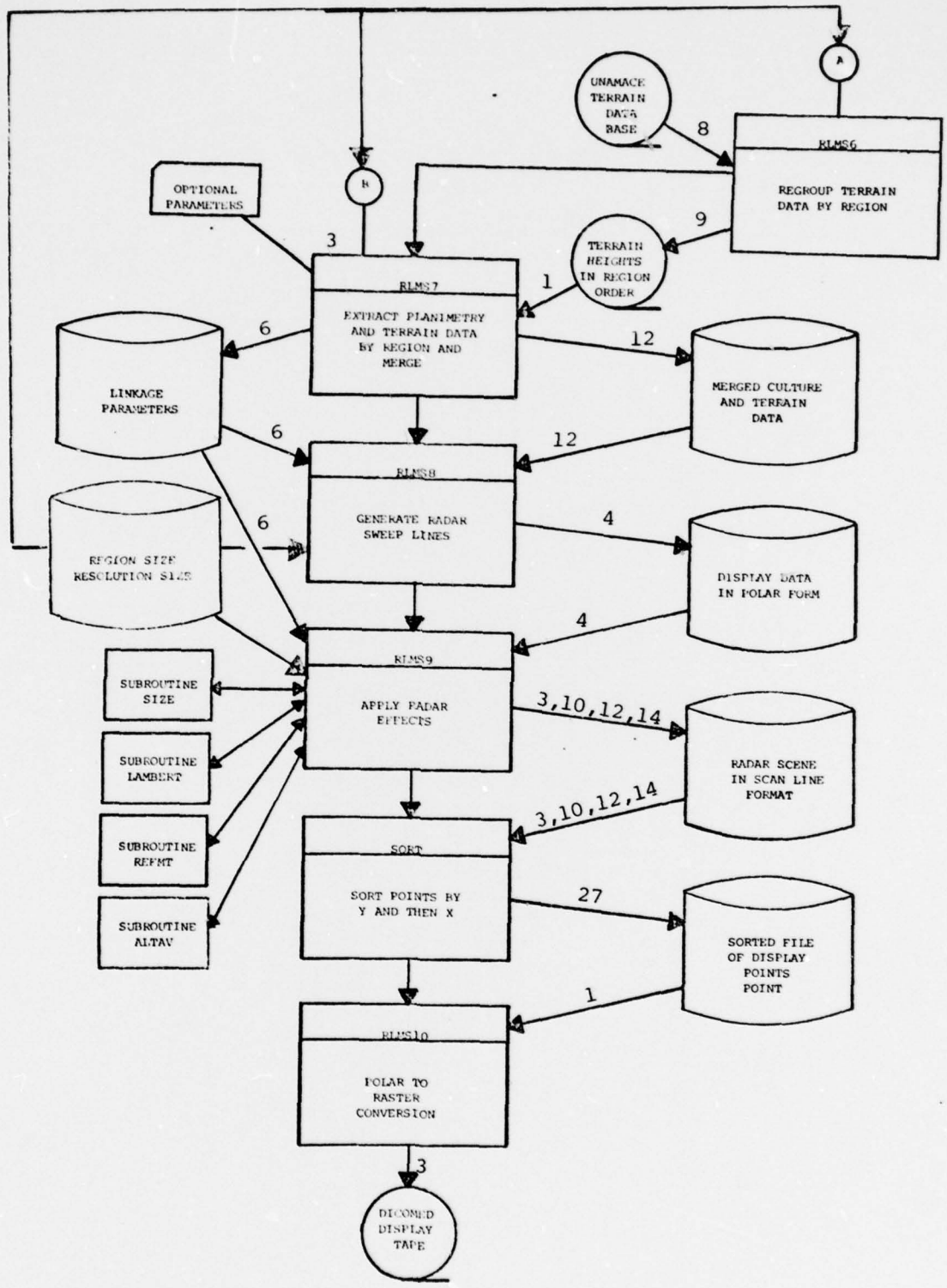

FIGURE I.1 - DRLMS PROGRAM AND DATA FLOW
(PAGE 2 OF 2)

as illustrated in Figure I.2. This is done for both "line" features such as roads and "area" features such as lakes. Clearly a point feature such as a building can be displayed in a similar fashion by using a single strip of unit length. For the area features, long horizontal "fill" strips are generated so that the area enclosed by the feature perimeter is now part of the feature. This is illustrated in Figure I.3. Each strip is defined by the X,Y coordinates of its left end, and by a delta-X value which is its length.

In order to process the map within the space limitations presented by computer memory size it is necessary to divide the map into small regions. The data for each region can then be processed separately. Program RSS3 divides the planimetry strips generated by RSS2 at fixed region boundaries. That is to say, the strips are assigned to their respective regions and a strip which overlaps several regions, say N of them, is broken up into N segments with each segment being assigned to the region in which it lies. In the process of accomplishing this, the X,Y coordinates of the left end of each strip are converted to values relative to the lower left hand corner of its respective region. We have therefore divided our map into a series of smaller maps which will eventually be paneled together to yield the original.

Program RSS4 is a sorting routine which reorders the planimetry data generated by RSS3. The output of RSS4 is an equivalent data base in which the data is ordered by the priorities of Table I.1. In other words, the planimetry strips are ordered first by ascending region number and then by ascending merge priority. (See the next paragraph for a discussion of the merge priority). For each feature, the line segments are then ordered according to increasing Y value, then according to increasing X value. The sorting procedure is made necessary by the processing requirements of program RSS5.

Program RSS5 is a merge program which is required because of a subtle aspect of the data base generated by the preceding software. The problem is illustrated in Figure I.4. Consider two features, say a city and a lake. Each of these has associated with it a series of strips describing its shape and location. Now, if the lake lies within the bounds of the city, a merge of the data is required since it is necessary to specify which feature is to be "on top", i.e. the lake strips must be copied over the city strips or the lake will not appear on the final picture. The output of RSS5, then, is a data base in which the contents of each region are described by horizontal strips, none of which overlap. Strips from features with low merge priorities (such as cities) are entered first and then written over where necessary by strips from features with higher merge priorities (such as lakes). The merge priorities are assigned by RSS3 on the basis of feature code.

Program RSS5 marks the end of the so-called planimetry preparation subsystem.

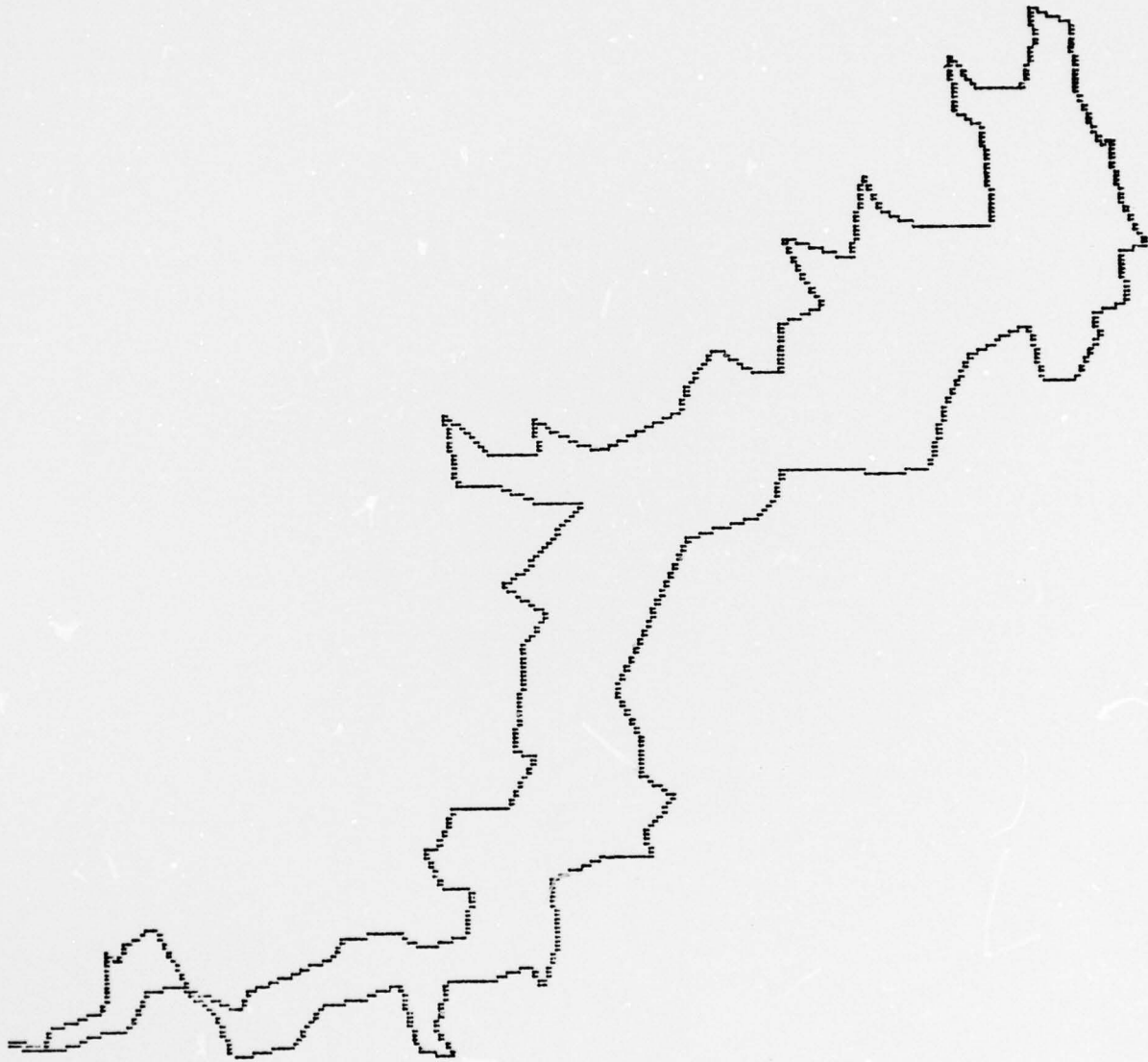

FIGURE I.2 - A TYPICAL FEATURE IN STRIP FORMAT

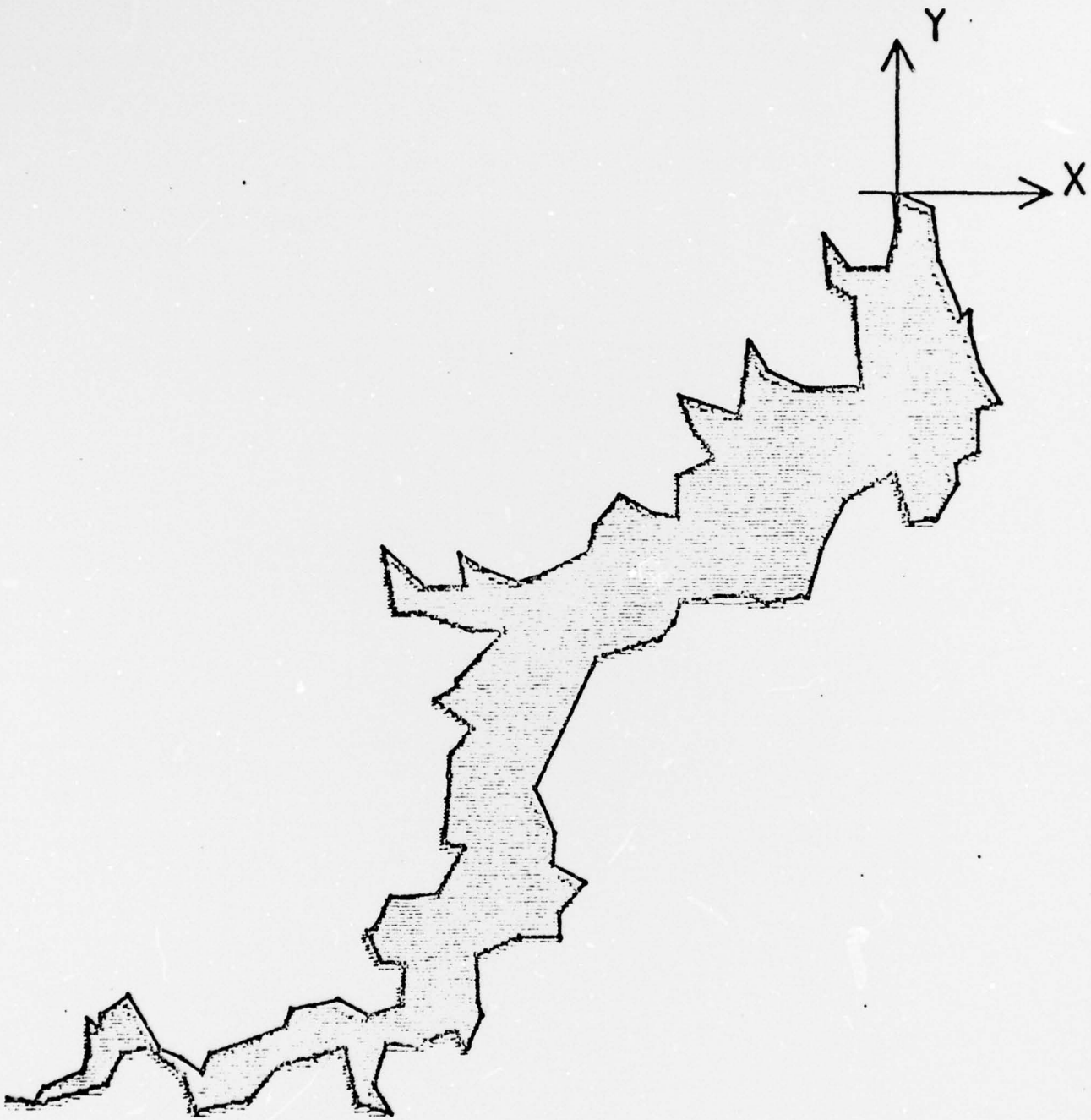

FIGURE I.3 - AREAL FEATURE SHOWING INTERIOR-FILL STRIP FORMAT

Program RSS6 is the terrain preparation program. As indicated above, the planimetry data is broken into regions in order to simplify processing. The terrain data must be similarly subdivided, and this is done in RSS6.

Present operation of the simulator calls for the generation of four (4) scenes for each target. Each of these scenes depicts the radar return of the terrain when viewed from a different altitude. In order to obtain such a complete set of scenes it is necessary to run RSS7 and RSS8 once at the highest altitude. Programs RSS9 and RSS10 must be run once for each altitude. The generation of a set of four scenes for a given target therefore requires one run of programs RSS1 through RSS8 and four runs of RSS9 and RSS10.

Program RSS7 merges the planimetry and terrain files for those regions lying within the radar ground range of the target. That is to say, the output from RSS7 consists of one record for each region within the radar range of the target. This record consists of an appropriate header, followed by the planimetry content of each point in the region followed by the elevation at each point within the region. A discussion of the size of the regions and the resolution cells within each region will be given in Chapter II.

Program RSS8 uses the cartesian data base output from RSS7 to construct a series of radial scan lines required to simulate a Plan-Position-Indicator (PPI) radar scene as illustrated in Figure I.5 This operation consists of a cartesian-to-polar coordinate transformation. The output from RSS8 therefore consists of N scan lines where $360^\circ/N$ is the angular increment between scan lines. The single record for each scan line contains the planimetry and elevation data for all points lying along the scan line, beginning at the target location and ending 20 nautical miles out. The planimetry data from RSS8 consists of intrinsic radar strength-of-returns that are assigned to each feature on the basis of feature code. Ground points not assigned to any special feature type are given a predetermined background return strength.

Program RSS9 applies the radar effects to the radial scan line data from RSS8. At the present time only three effects are considered. One is a Lambert's Law effect which determines the percentage of the incident radar signal reflected back to the source. The second is a shadow effect which takes into account the fact that certain areas on the ground may be blocked from view by tall objects (i.e. mountain peaks) lying in the line-of-sight from the radar location to the area in question. The third is the altitude layover effect which accounts for the fact that ground points with elevations different from that of the target (i.e. the point directly below the radar) will appear shifted from their true position.

These effects will be discussed in more detail in Chapter II. RSS9 also contains a subroutine used to scale the final image so that scenes generated from different altitudes will all be the same size when displayed on the DICOMED plotter.

ORDERING PRIORITY	PARAMETER
1	REGION NUMBER
2	MERGE PRIORITY
3	Y COORDINATE
4	X COORDINATE

TABLE I.1 - ORDERING PRIORITY FOR RLMS4 SORT ROUTINE

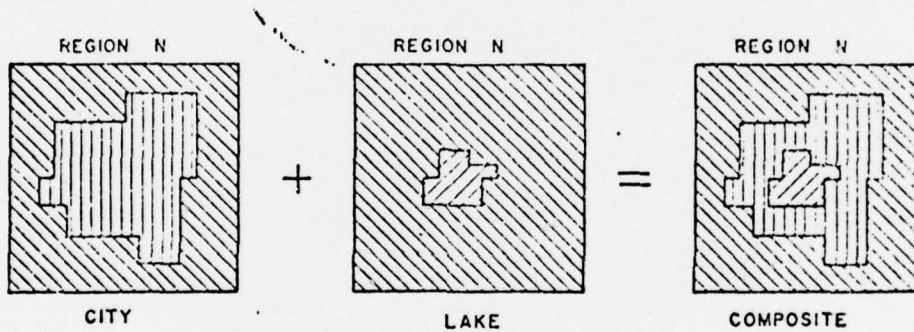

FIGURE I.4 - MERGE PROCESS ILLUSTRATED

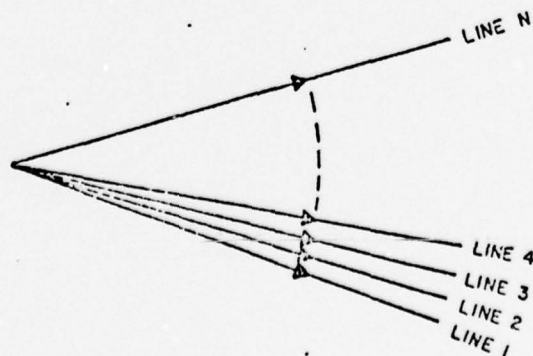

FIGURE I.5 - RADIAL SCAN LINES. THE RADAR TARGET IS LOCATED AT THE APEX

At this point the radar scene is completed. The SORT program and RSS10 are now used to convert the scene information back to cartesian form and to place the information on tape in a raster format compatible with the DICOMED plotter.

2. File Structure

The file structure for RSS is as indicated in Figure I.1. The numbers associated with each file in the diagram are the file I.D.'s used in the programs and this information will be of use in Chapter III when we discuss operating procedures.

As is evident, all intermediate storage is done on disc. Inputs to the simulator consist of the planimetry data tape to RSS1, the terrain data tape to RSS6, and card input to RSS1, RSS2, RSS7, and RSS9. These card inputs will be discussed in Chapter II.

II. SOFTWARE DESCRIPTION

1. Program RSS1

1.1 Inputs

This program requires both tape and card input. The tape input consists of a digitizer tape containing the (X,Y) coordinates of the points defining the location of the planimetry features on the map. The format of this tape is presented in Figure II.1.

Each small box represents a 6-bit BCD character, and each physical record contains 1800 such characters (or 180 CDC words). The beginning of the information for each feature is marked by a "(" . Following this are twelve special characters which are of no use in RSS and are discarded. The next five characters contain the feature code. A tabulation of the possible feature codes is given in Table II.1. Following the feature code is a pen-down command which signals the beginning of the (X,Y) data.

The (X,Y) data for the feature begins in the twentieth character of the feature record. Each coordinate is in an F7.3 format. This means that each digit (as well as the decimal point) is represented as a separate character, with the maximum coordinate value being 999.999. All coordinates are given in inches relative to the table origin. The last Y-value for the feature is followed by a "U" which is the pen-up command.

A feature record may begin anywhere in a block of data, and may require more than one block. Similarly, a single block may contain the information for several features of small size. A feature record may be broken at any point except in the middle of the string of characters representing the feature code or a coordinate. A "B" is used to signal the end-of-information for a particular block.

The card input to RSS1 consists of a single card containing the X and Y offsets. These numbers are subtracted from every (X,Y) pair for every feature and are required to bring the origin of the planimetry data into coincidence with the origin used for the terrain data. The information is entered in a 2F10.3 format.

1.2 Description of Processing

For each feature, RSS1 begins by pulling-off and reconstructing the feature code and (X,Y) data pairs. All other information on the data tape is discarded. The X and Y offsets are subtracted from the (X,Y) pairs, and any point having a negative coordinate is discarded since it lies off of the adjusted map sheet. As mentioned earlier, this procedure is necessary to bring the coordinate origin of the planimetry map into coincidence with that of the terrain map. Failure to do this will cause a systematic error in the placement of the planimetry data.

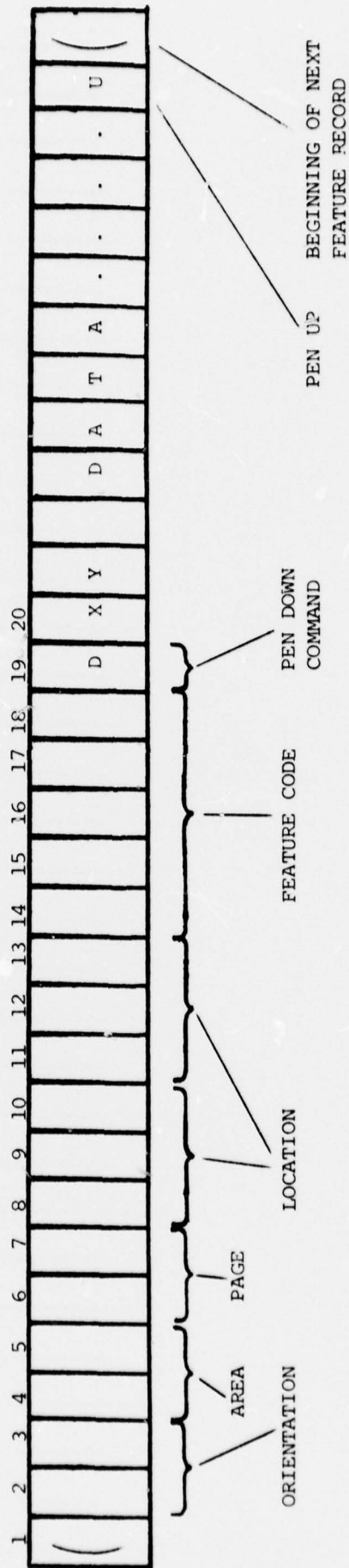

FIGURE II.1.1 - FORMAT OF DIGITIZER TAPE

FEATURE TYPE	FEATURE CODE
RADAR GREY SHADES	20101 THRU 20320
LARGE RIVERS (WATER ON LEFT)	10110
LARGE RIVERS (WATER ON RIGHT)	10120
DAMS	10130
MARSHES AND SWAMPS	10140
LAKES	10150
ISLANDS	10160
RIVERS AND STREAMS	10170
RAILROAD YARDS	10210
RAILROADS	10220
TOWNS AND SUBURBS	10310
MEDIUM CITIES AND COMMERCIAL AREAS	10320
BIG CITIES AND INDUSTRIAL AREAS	10330
LARGE ISOLATED BUILDINGS	10340
INTERSTATE HIGHWAYS AND TURNPIKES	10410
MAJOR ROADS	10420
SECONDARY ROADS	10430
UNPAVED ROADS AND TRAILS	10440
AIRPORT	10450
POWER LINE TOWERS (WITH CABLES)	10510
DRIVE-IN MOVIES	10520
FIRE OR RADIO TOWERS	10530
CEMETERIES	10540
POL AREA	10550
HARDWOOD FOREST	10610
EVERGREEN FOREST	10620
MEADOWS AND GRASSY FIELDS	10630
DRY ROCKY AREAS	10640
SAND AND SAGEBRUSH AREAS	10650
SNOW COVERED AREAS	10660
DRY RIVERBEDS, CANALS, AND STORM DRAINS	10670
DRY LAKE BEDS AND GULCHES	10680

Reproduced from
best available copy. 

TABLE II.1 - CORRESPONDENCE BETWEEN FEATURE TYPES
AND FEATURE CODES

The data for areal features, such as lakes or cities, is then checked to see that a closed polygon is formed; and closure is performed if required. Such a closure of all polygons is required by RSS2. Polygons lying partially off the map sheet are closed along the sheet boundary.

In order to simplify later processing, the feature codes of Table III.1 are mapped into the set of integers (1,60). This permits easy formulation of translation tables which match feature codes with feature attributes such as merge priority and intrinsic radar return intensity.

Finally, RSS1 does special processing on certain features. If a feature is a power line the towers are separated from the cable and each piece is written out as a separate feature. A wide river is represented by two separate features, one defining its right bank and another defining its left bank. In addition to maintaining the two banks, RSS1 combines them into a third feature which is a closed polygon representing the water surface.

1.3 Output

RSS1 outputs the processed planimetry file to disc. Each feature is represented by a record with the following format:

Word 1: Feature code

Word 2: Total number of coordinates in the record i.e. twice the number of points N.

Word 3-word 2N+2: X,Y data

RSS1 also outputs a printout identifying the type and location of all features on the map sheet. A sample of this printout is given in Figure II.2.

1.4 Timing and Cost

For a typical map sheet containing 131 features, RSS1 requires 92 cp seconds execution time and 3½ minutes wall-clock time on ETL's CDC 6400. Run cost is approximately twenty-four dollars.

2. Program RSS2

2.1 Input

Program RSS2 requires two inputs. The first is the output file from RSS1. This transfer is accomplished through the use of SCOPE control cards and will be discussed in Chapter III. The second is a single card input. The format for this card is I20, 15X, I5, 8X, I2 and its content is as follows:

SEQUENCE NO.	FEATURE CODE	DESCRIPTION	CLOSURE	NO. OF POINTS	MIN X	MAX X	MIN Y	MAX Y
1	32	DRY LAKE	YES	465	32,601	33,201	15,824	17,211
2	32	DRY LAKE	YES	2023	27,600	33,182	5,750	16,771
3	32	DRY LAKE	YES	1650	23,991	25,487	4,002	5,742
4	32	DRY LAKE	YES	1694	2500	4,233	4,231	2,539
5	32	DRY LAKE	YES	1736	2500	5,267	4,228	4,392
6	31	CANAL	NO	564	338	5,267	16,501	23,979
7	22	LEFT BANK	NO	630	235	6,033	19,202	2,773
8	21	RIGHT BANK	NO	710	235	1,051	16,707	2,913
9	23	RIVER FILL	YES	1341	295	1,051	16,957	2,913
10	10	SAL. RIVER	NO	174	3,254	1,910	25,646	29,306
11	16	SAL. RIVER	NO	475	2654	3,319	27,955	28,037
12	16	SAL. RIVER	NO	297	2,722	2,001	27,351	27,390
13	16	SAL. RIVER	NO	613	3,335	4,237	25,712	27,327
14	16	SAL. RIVER	NO	373	3,633	5,313	25,712	26,712
15	16	SAL. RIVER	NO	245	5,277	9,131	27,000	28,059
16	16	SAL. RIVER	NO	121	5,075	5,314	25,327	27,225
17	16	SAL. RIVER	NO	433	7,758	3,759	21,341	25,115
18	16	SAL. RIVER	NO	497	1,766	5,429	20,942	21,555
19	16	SAL. RIVER	NO	85	3,135	4,132	19,321	20,934
20	16	SAL. RIVER	NO	233	7,411	3,339	25,765	26,520
21	15	SAL. RIVER	NO	653	7,332	11,344	20,155	26,784
22	16	SAL. RIVER	NO	370	9,431	9,973	26,174	28,609
23	16	SAL. RIVER	NO	304	9,742	10,715	26,339	28,773
24	16	SAL. RIVER	NO	479	13,037	16,872	25,376	29,951
25	15	SAL. RIVER	NO	447	14,745	15,757	26,732	31,474
26	16	SAL. RIVER	NO	555	12,743	13,439	20,669	21,564
27	16	SAL. RIVER	NO	1034	16,121	25,382	23,920	31,237
28	10	SAL. RIVER	NO	386	19,927	23,707	26,715	27,557
29	16	SAL. RIVER	NO	358	19,949	23,619	26,662	27,125
30	16	SAL. RIVER	NO	330	22,284	23,385	26,145	27,071
31	16	SAL. RIVER	NO	106	23,837	24,516	25,709	26,273
32	16	SAL. RIVER	NO	311	19,467	22,685	25,389	26,583
33	15	SAL. RIVER	NO	446	17,097	21,777	24,315	25,332
34	16	SAL. RIVER	NO	1078	13,362	23,659	21,331	24,433
35	16	SAL. RIVER	NO	282	26,486	29,836	23,236	24,552
36	16	SAL. RIVER	NO	424	29,445	31,895	19,821	23,236
37	16	SAL. RIVER	NO	780	24,101	30,602	20,132	21,470
38	16	SAL. RIVER	NO	584	24,733	30,533	19,333	21,563
39	16	SAL. RIVER	NO	1278	22,458	26,464	5,334	11,948
40	16	SAL. RIVER	NO	833	24,357	28,252	11,637	13,532
41	15	SAL. RIVER	NO	321	29,256	31,919	13,335	16,637
42	16	SAL. RIVER	NO	421	22,350	23,585	10,370	11,971
43	16	SAL. RIVER	NO	412	22,596	23,755	9,491	11,133
44	16	SAL. RIVER	NO	755	24,608	27,715	6,107	11,524
45	16	SAL. RIVER	NO	419	13,543	21,751	10,840	13,100
46	16	SAL. RIVER	NO	537	20,713	22,543	7,315	11,855
47	16	SAL. RIVER	NO	378	12,848	16,256	7,534	8,362
48	15	SAL. RIVER	NO	314	12,530	15,455	5,445	7,043

FIGURE II.2 - SAMPLE PRINTOUT FROM RSSI

Columns 1-20: contain the map scale, e.g. if the map scale is 1:100,000, this field contains the number 100,000.

Columns 21-35: blank

Columns 36-40: contain the size of the grid resolution elements used to label points in a region of planimetry data. This value must be expressed in units of meters x 1000.

Columns 41-48: blank

Columns 49-50: contain the region size, i.e. the number of resolution elements along a region edge. The restrictions on this value are (1) it must not exceed 48 and (2) it must be a multiple of 4.

2.2 Description of Processing

As mentioned previously, RSS2 generates the data strips used to describe planimetry features in RSS. The process of strip generation can be roughly described as follows.

First, the map scale and grid size are used to express all X,Y data pairs in units of the grid size. Now consider two consecutive data points (X_1, Y_1) and (X_2, Y_2) . To construct the data strips corresponding to these two points begin by calculating the inverse slope.

$$s = \frac{\Delta X}{\Delta Y} = \left| \frac{X_1 - X_2}{Y_1 - Y_2} \right|$$

The number of strips to be generated is given by $Y_1 - Y_2$, i.e. each strip is of unit width. The first strip begins at $Y=Y_1$, $X=X_1$ and is of length $X+S$, since X changes by a distance equal to S when Y changes by 1. The second strip has $Y=Y_1-1$, $X=X_1+S+1$ and $\Delta X=S$, and so on for the $|Y_1 - Y_2|$ strips generated between the two points. The procedure is then repeated for (X_2, Y_2) and (X_3, Y_3) , etc.

This description is of course an oversimplification. The process actually does not employ integer arithmetic since S may not be an integer. Also, the sign of the slope is a pertinent quantity since it determines whether successive strips move to the left or to the right. However, the essence of the method is as described above.

The data strips for each feature are sorted by Y and then X. The placement of the data in this form is required by RSS5 which merges the strips for overlapping features.

2.3 Output

RSS2 outputs two disc files. The first file outputs the data for each feature in blocks of 1800 words. The first six words of the first block contain general information about the feature, with word 2 containing the feature code. Beginning in word 7 are the values of the quantities describing the data strips. The format of this information is as follows:

<u>WORD</u>	<u>CONTENT</u>
6+4N-3	Y-value for the Nth strip
6+4N-2	X-value for the beginning of the Nth strip
6+4N-1	ΔX value for the Nth strip; equals the total number of resolution elements covered by the strip. The endpoint of the strip is then at $X + \Delta X - 1$
6+4N	Specularity angle for the Nth strip. This quantity is used to determine abnormal radar return qualities and is not presently used in RSS, although it is calculated.

The second file is a two-word file containing the following map size values:

Word 1	Grid Resolution element size (meters X 1000)
Word 2	Region size

RSS2 also outputs a printout of the header information for each feature.

2.4 Timing and Cost

Because of the large processing requirements, RSS2 is an expensive and time-consuming program to operate. For the file of 190 features 1465 cp seconds and 42 minutes wall clock time were required for execution. Run cost was 353 dollars.

3. Program RSS3

3.1 Inputs

Program RSS3 requires as input the output files from RSS2. No card input is needed. Information linkage is accomplished through the use of SCOPE control cards as described in Chapter III.

3.2 Description of Processing

RSS3 assigns the planimetry data strips to regions. Each planimetry region is a square whose sides represent a ground distance equal

to the product of the region size and the resolution grid size. Numbering of these regions begins in the southwest corner of the map with the assignments being made sequentially left to right and bottom to top.

The procedure used to assign the planimetry strips to their respective regions is a simple one. Consider for example, a strip with the following characteristics:

Y = 750
 X = 875
 Δ X = 24
 Region size = 32
 Resolution = 156.25 feet

This means that the strip begins 117,187 feet north (750 X 156.25) and 136,718 feet east (875 X 156.25) of the map origin. We have assumed that each region contains 32 increments along each edge so:

$$R_Y = 750/32 = 23.43750$$

$$R_X = 875/32 = 27.34375$$

If we assume that each horizontal row of regions can contain at most 331 regions, then the region number for the beginning of the strip is:

$$N_r = 331 * (23) + 28 = 7641$$

The (X,Y) coordinates of the beginning point relative to the first grid element in the region is:

$$Y = 0.43750 * (32) = 14$$

$$X = 0.34375 * (32) = 11$$

Since Δ X = 24, the end point of the strip is at X = 11+24-1 = 34. The maximum address within a region is 32, so this strip overflows into the next region to the east. We therefore wind up with two strips as follows:

	<u>STRIP 1</u>		<u>STRIP 2</u>
Region	7641	Region	7642
Y	14		14
X	11		1
Δ X	22		2

RSS3 also assigns merge priorities for each feature code. This is done through the use of a translation table which is hard-coded as a DATA statement.

3.3 Output

The output from RSS3 is placed on disc in the form of card images. Each image is labeled by the region number and feature code. It

contains the merge priority for the feature and the descriptive information for up to seven planimetry strips.

The only printed output from RSS3 is a message indicating the end of processing.

3.4 SORT Routine (RSS4)

Program RSS3 employs the CDC SORT/MERGE package to order the card images. For the purposes of this document, we will call this routine RSS4.

In preparation for RSS5, the card images are sorted in the following order:

<u>ORDER</u>	<u>ATTRIBUTE</u>
1	Region Number
2	Merge Priority
3	Y-value of first strip
4	X-value of first strip

Although the reader is directed to the CDC SORT/MERGE manual for complete details on the operation of the SORT/MERGE package, we present here a listing and brief description of RSS4.

```
SORT, VAR=DISC
BYTESIZE,6
FILE,SORT=TAPE1,OUTPUT=TAPE2
FIELD,REGION(1.1,5,DISPLAY),PRIORITY(6.1,2,DISPLAY),
,INTY(13.1,2,DISPLAY),INTX(15.1,2,DISPLAY)
KEY,REGION(A,OWN),PRIORITY(A,OWN),INTY(A,OWN),INTX(Z,OWN)
SEQUENCE,OWN(Ø,0,1,2,3,4,5,6,7,8,9)
OPTIONS,RETAIN
END
```

The FIELD card lists the attributes to be sorted in order of decreasing priority. It indicates the format of the data, which in our case is CDC DISPLAY code, and its location within the record. The KEY card gives the direction of the sort (i.e. the "A" indicates that the numbers are to be placed in ascending order) and the ordering scheme, which in our case is the sequence OWN. The SEQUENCE card is used to define an ordering sequence other than one of the standard sequences. This card is required in RSS4 because a blank in display code is represented by 55B and this value is greater than that assigned to the integers. Without a special sequence, a number like Ø1023 would, for example, be placed after Ø16486 in an ascending order sort of the card images.

Clearly, the output from RSS4 is in the same format as that from RSS3. Only the ordering of the records is changed.

3.5 Timing and Cost (RSS3 and RSS4)

For our typical data base of 190 features the running time for the combination program is 231 cp seconds and 2 minutes wall clock time. Cost for the run is thirty-four dollars.

4. Program RSS5

4.1 Inputs

RSS5 requires the output file from RLMS4 and the two word disc file from RSS2. It does not require any card input.

4.2 Description of Processing

This program merges the planimetry strips so that no strips overlap. The procedure has been discussed in Chapter I and is conceptually quite simple. The records containing the planimetry strips have already been sorted by region number and merge priority. The merge priority scheme is set up so that those features which may be overwritten appear before those which may not. For example, for a given region, strips describing a lake appear before those describing an island, and those describing a road occur after those describing the island. The scheme is presently imperfect (consider an island with a lake on it) but can be expected to work in the vast majority of cases.

In essence, RSS5 simply copies the planimetry strips into a core array in the order in which they appear on the input file. This array becomes an image of the region structure as successive strips are copied into it. An empty record is written for those regions which contain no planimetry data.

As an example of the operation of RSS5, consider two planimetry strips, one being part of a lake and the other being part of a city. Take the location and size of these strips to be as follows:

Lake Strip

$$Y = 25$$

$$X = 11$$

$$\Delta X = 6$$

City Strip

$$Y = 25$$

$$X = 8$$

$$\Delta X = 15$$

Clearly, this portion of the lake overlaps the city. RSS5 takes these strips and generates three (3) strips, two belonging to the city and one belonging to the lake. The location and size of these strips is as follows:

Lake Strip

$$Y = 25$$

$$X = 11$$

$$\Delta X = 6$$

City Strip

$$Y = 25$$

$$X = 8$$

$$\Delta X = 3$$

$$Y = 25$$

$$X = 17$$

$$\Delta X = 6$$

Notice that these strips do not overlap.

4.3 Output

As just mentioned, RSS5 outputs a record for each region on the map regardless of whether or not that region actually contains any planimetry data. The first word of the record contains the total number of strips contained in the region, while the remaining words contain the information describing the strips. Each strip is described by one word, with the data being packed as follows:

<u>BITS</u>	<u>INFORMATION</u>
31-36	Y-coordinate of strip
25-30	X-coordinate of beginning of strip
19-24	X for strip
7-18	Specularity angle for strip
1-6	Feature code for strip

The blocks are written to a random access file with the location of each block being labeled by the corresponding region number.

The printed output from RSS5 includes a printout of all regions that were padded with empty data to yield a region size with a perfect square, and an end-of-processing message.

Timing and Cost

This program required 216 cp seconds and 2 minutes wall clock time to process the strips for 190 features. Run cost was forty-four dollars.

5. Program RSS6

5.1 Inputs

The input to this program is a tape containing elevation values for the area covered by the map and the two word disc file output from RSS2.

The first record on the tape is a 36 word header. Each entry in the header is an integer representation of the actual data obtained by multiplying the value by 1000 and rounding. The first 20 words contain information pertaining to the location on the earth of the area from which the data was obtained and the values of parameters required in producing the cartesian projection of the map. These quantities will not concern us here. The last 16 entries are as follows:

Word 21: The total number of records (profiles) on the tape, not counting the header.

Word 22: The total number of elevation points per record. Elevations are unsigned 15 bit integers, in feet, packed 4 per word.

Word 23-25:

Geographic latitude in degrees, minutes, and seconds of the radar target.

Word 26: Ground distance in meters between the UNAMACE point of tangency north to the target.

Word 27-29:

The longitude in degrees, minutes, and seconds of the radar target.

Word 30: The ground distance in meters from the UNAMACE point of tangency west to the target.

Word 31: The ground distance in meters from the first elevation profile (upper NW corner of the elevation data) north to the radar target. A negative value indicates that the target is south of the first elevation point.

Word 32: The ground distance in meters from the first elevation profile west to the target. This number is also negative.

Word 33: Target ID Code

Word 34: Ground spacing between points of a profile in meters. Presently this value must be equal to the grid resolution size output by RSS2.

Word 35: Ground spacing between profiles in meters. Equals word 34 at present time.

Word 36: Zero fill word.

Following this header are a series of records - one for each profile line. Each profile contains the elevation values for a west-to-east-running strip of terrain, with the first profile corresponding to the northernmost part of the map (a contrast to the SW origin for digitizing the planimetry).

5.2 Description of Processing

The input data base is characterized by resolution elements equal to those of the planimetry file with the data being arranged in horizontal strips covering the entire width (east-west dimension) of the map sheet. RSS6 reformats the data in these strips into regions with dimensions equal to the dimensions used by the planimetry file. The regions are numbered from the lower left corner of the map just as in the planimetry data file.

For example, if the region size is defined as 24 by RSS2, then 24 profiles are read at a time into a core array. From word 22 of the header it can be determined how many regions (in the horizontal direction) are defined by this data. Similarly, word 21 of the header permits the determination of the Y-coordinate (i.e. number of regions in the Y-direction) of each row. From this information it is possible to assign a region number to each group of 24 X 24 data points thereby defining a grid.

5.3 Output

The information for each region is stored in a one-dimensional array. The first word contains the region number while the remaining words contain the elevation data packed four per word. The packing order is such that if there are N resolution elements along a region edge, each sequential group of N/4 words contains the elevation data for one row of resolution elements within the region beginning at the western edge, with the southern-most row appearing first, i.e.:

<u>WORD 1</u>	<u>REGION NUMBER</u>
Word N+1	Elevation value for row=(N-1)/IR +1 column = N-IR * (row-1), where IR is the number of resolution elements along a region edge.

During processing, each region record is placed on a random access file. When all regions have been processed, the records are read back into core in region order and rewritten to the disc.

5.4 Timing and Cost

Program RSS6 requires 117 cp seconds and 16 minutes wall clock time for execution. Run cost is approximately forty-three dollars.

6. Program RSS7

6.1 Input

Program RSS7 requires tape, disc, and card input.

The tape required is the output tape from RSS6, while the disc file is the output of RSS5 and the two word file from RSS2. The card input supplies certain NAMELIST quantities and their meanings are as follows:

<u>QUANTITY</u>	<u>MEANING</u>
IFREQ	The number of radial scan lines to be constructed per degree. For example IFREQ=2 will result in 720 scan lines separated by $1/2^{\circ}$. Default: IFREQ=2
ITERR	Control variable. INTERR=1 causes the planimetry data to be merged with the terrain data. INTERR=0 causes the terrain data to be ignored. Default: INTERR=1

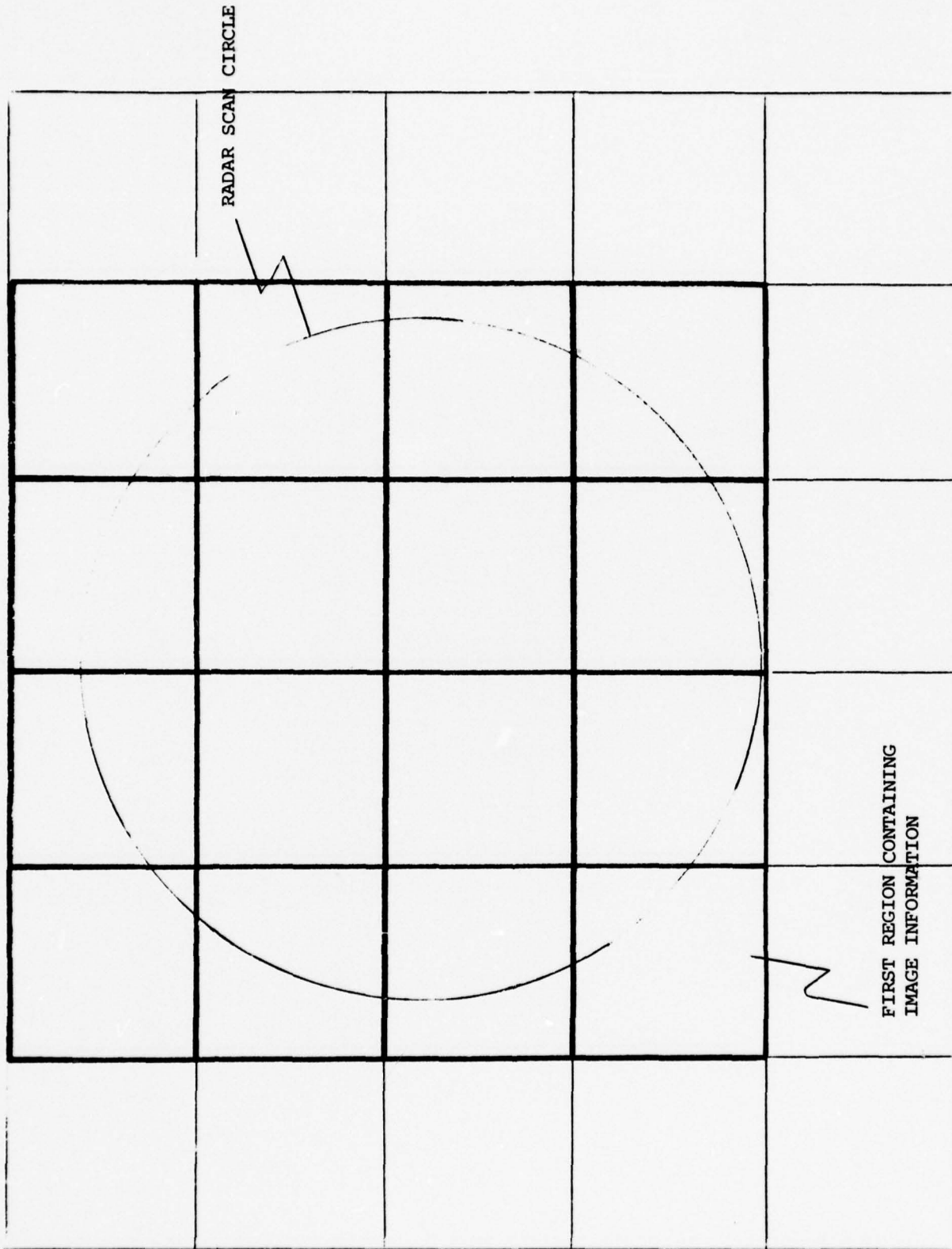

FIGURE II.3 - EXAMPLE OF REGION SUBSET EXTRACTED BY RSS7

ALTTDE The maximum altitude of the radar above
the radar target. The maximum value of this field
is 32000
Default: ALTTDE= 32000 feet

X X-coordinate of the radar target in meters relative to
the southwest corner of the map

Y Y-coordinate of the radar target in meters relative to
the southwest corner of the map

6.2 Description of Processing

The purpose of RSS7 is to merge the planimetry data file from RSS5 with the terrain data file from RSS6 and to determine certain map related quantities needed to construct the radar scene.

Using information from the terrain file header record, the region address of the radar target is determined. With this point as its center, an imaginary circle is then constructed whose radius is equal to the ground range of the radar. A square circumscribed about this circle will then contain all of the regions required to produce the radar scene at the chosen altitude; the rest may be discarded. This procedure is illustrated in Figure II.3. For each region overlapped by the circumscribed square, the terrain and planimetry data are merged into a single record labeled by the region number.

6.3 Output

RSS7 outputs two files. The first contains two five-word records containing descriptive information required in the reconstruction of the radar scene.

<u>RECORD1</u>	<u>CONTENTS</u>
WORD1	Ground range of the radar in meters.
WORD2	Radar height (in meters) above target ground altitude
WORD3	X-coordinate of the radar target in meters relative to the southwest corner of the map.
WORD4	Y-coordinate of the radar target in meters relative to the southwest corner of the map.
WORD5	Elevation (in meters) of the radar target above sea level. The sum of this value and WORD2 gives the radar altitude above sea-level.
 <u>RECORD2</u>	
WORD1	Maximum number of regions in the X-direction of the map sheet; presently set at 331.

the target, and θ the polar angle. The quantity IFREQ defines the values of θ to be used in the generation of the scan lines. These values are:

$$\theta_n = n/\text{IFREQ}, 0 \leq n \leq 360 \cdot \text{IFREQ}$$

and result in the generation of a circle consisting of $360 \cdot \text{IFREQ}$ scan lines separated by an angular increment of $1/\text{IFREQ}$ degrees. The radar range R is expressed in units equal to the grid spacing for the planimetry data. The variable r_p therefore has the range $0 < r_p \leq R$.

With the parameters thusly defined, the generation of the sweep lines proceeds as follows. We assume that the initial value of $\theta_n = 0$, i.e., $n=0$ and that we begin each scan line $r_p = 1$.

- A) Calculate $\text{COS}\theta_n$ and $\text{SIN}\theta_n$
- B) Calculate X_p and Y_p
- C) Calculate the region in which (X_p, Y_p) lies
- D) If the record for this region is already in core, go to (G)
- E) Read the record for this region into core
- F) Copy the planimetry strip information for this region into a $IK \times IK$ core array which serves as an image of the region. Radar return intensity levels are assigned in correspondence with the feature codes by using an internal translation table. The radar return intensity for resolution elements not covered by planimetry data is set equal to a predetermined background intensity. The result is that $\text{ARRAY}(I, J)$ contains the radar return intensity (from planimetry only) for the resolution element at $X=I, Y=J$.
- G) Calculate which resolution element contains (X_p, Y_p) .
Denote this by $\text{ARRAY}(I_p, J_p)$
- H) Copy $\text{ARRAY}(I_p, J_p)$ and the corresponding terrain value from the input region record into a linear array which stores the information for the scan line.
- I) Let $r \rightarrow r+1$.
- J) If $r \leq R$ go to (B.)
- K) Let $\theta \rightarrow \theta + 1/\text{IFREQ}$
- L) If $\theta > 360^\circ$ we are finished. If $\theta \leq 360^\circ$ go to (A.)

RANGE DATA EXTRACT FOR THE FOLLOWING RADAR PARAMETERS:
 HEIGHT DEPRESSION ANGLE RADIUS OF COVERAGE LOCATION(X,Y)
 (FT) (DEGS) (N.M.) (N.M.)
 32000.0 3.04 19.194 20.0456 21.8591
 NUMBER OF REGIONS OF COVERAGE= 46 STARTING REGION NUMBER= 9951

OUTPUT DATA FOR THE FOLLOWING REGIONS WAS OUTPUT:
 (X,Y) (REGION) (X,Y)

1000	27	1010	36	1012	25	1013	37	1017	1	1018	20	1019	23	1025	32	1027	10	1028	13
1001	18	1032	16	1035	32	1036	35	1038	34	1327	32	1328	6	1331	2	1332	31	1333	22
1002	12	1038	1	1344	55	1344	20	1355	11	1356	21	1357	11	1358	21	1363	5	1364	21
1005	5	1355	32	1357	35	1363	35	1372	12	1659	40	1664	29	1665	15	1667	23	1668	9
1006	64	1645	32	1644	32	1649	8	1691	3	1696	38	1697	27	1698	44	1699	29	1700	44
1007	9	1702	25	1703	42	1388	36	1989	28	1990	30	1991	20	1994	22	1995	15	1996	25
1008	32	2005	64	2017	33	2018	11	2019	46	2020	45	2021	2	2022	16	2023	9	2024	14
1009	5	2026	11	2027	36	2028	4	2029	53	2030	55	2031	20	2032	69	2033	35	2034	25
1010	34	2401	25	2322	12	2325	26	2326	12	2330	14	2331	18	2337	36	2338	28	2347	32
1011	30	2350	32	2351	32	2358	35	2359	5	2360	21	2361	30	2362	103	2363	64	2364	23
1012	45	2651	21	2652	31	2653	28	2654	30	2655	9	2656	42	2657	3	2662	32	2663	32
1013	37	2675	12	2677	37	2678	22	2680	16	2681	16	2682	32	2689	32	2691	32	2693	52
1014	59	2695	28	2695	9	2381	32	2985	14	2487	47	2993	14	2994	18	2999	32	3000	32
1015	24	3007	8	3008	31	3011	32	3012	12	3013	20	3020	32	3022	36	3024	32	3025	43
1016	45	3027	29	3312	32	3318	41	3325	50	3326	12	3327	1	3330	32	3331	11	3332	21
1017	43	3333	22	3341	4	3342	28	3343	32	3351	32	3353	32	3355	32	3357	64	3360	42
1018	12	3343	55	3355	61	3357	3	3359	8	3359	11	3660	10	3661	36	3362	8	3363	25
1019	23	3363	12	3363	6	3367	31	3668	38	3672	32	3673	14	3674	13	3682	32	3683	31
1020	6	3685	2	3686	32	3688	12	3689	91	3694	32	3977	6	3978	32	3979	51	3981	41
1021	31	3987	1	3988	32	3992	32	3995	27	3996	18	3997	35	3998	19	4003	32	4004	32
1022	21	4013	12	4014	32	4016	2	4017	41	4018	9	4019	40	4020	32	4305	45	4305	27
1023	47	4308	25	4308	49	4317	32	4319	13	4320	19	4323	32	4325	9	4326	6	4327	46
1024	40	4333	31	4334	31	4335	2	4343	32	4345	32	4346	32	4349	23	4350	9	4351	32
1025	9	4337	34	4648	32	4651	29	4652	3	4653	2	4654	66	4655	14	4655	3	4658	41
1026	29	4660	20	4661	8	4664	48	4665	16	4673	20	4674	12	4675	26	4675	6	4677	32
1027	32	4682	32	4673	28	4979	4	4983	46	4985	64	4987	12	4988	38	4989	4	4990	32
1028	13	5003	12	4994	1	4995	24	5003	6	5004	26	5005	13	5005	19	5007	26	5008	12
1029	5	5010	53	5013	32	5019	32	5314	48	5315	29	5316	64	5318	18	5319	14	5321	32
1030	32	5323	26	5327	12	5338	5	5339	2	5340	24	5341	49	5344	32	5641	6	5640	32
1031	2	5642	18	5643	27	5644	14	5645	111	5646	62	5647	87	5648	31	5649	23	5652	34
1032	18	5654	29	5655	3	5655	31	5667	1	5669	14	5670	18	5671	35	5672	32	5675	32
1033	7	5663	27	5969	8	5970	41	5971	34	5972	25	5973	19	5975	59	5977	24	5978	80
1034	32	5980	10	5981	13	5982	11	5983	32	5984	11	5985	7	5986	19	5994	13	5995	19
1035	32	6000	20	6000	12	6002	45	6003	19	6006	32	6231	2	6292	6	6293	38	6300	32
1036	31	6302	22	6303	7	6308	65	6309	72	6310	7	6313	3	6314	44	6317	32	6323	3
1037	27	6329	35	6328	32	6329	16	6330	41	6332	4	6333	60	6337	12	6624	1	6625	31
1038	17	6332	15	6633	32	6639	32	6640	67	6645	46	6646	7	6647	19	6348	13	6654	32
1039	32	6650	47	6650	14	6661	32	6662	7	6663	25	6664	32	6956	32	6953	13	6659	4
1040	5	6951	14	6952	10	6953	39	6954	34	6970	52	6971	43	6975	14	6376	18	6977	32
1041	32	6954	13	6985	5	6987	32	6988	4	6989	28	6990	9	6991	16	6992	16	6993	32
1042	12	6993	3	7237	16	7238	16	7239	32	7231	19	7294	32	7295	32	7301	63	7302	32
1043	29	7307	3	7308	32	7309	32	7317	20	7318	3	7319	31	7322	32	7323	30	7324	2
1044	4	7519	32	7620	3	7625	32	7626	32	7631	18	7632	46	7633	32	7638	32	7639	62
1045	2	7545	10	7646	18	7648	16	7649	20	7652	29	7653	3	7654	32	7661	32	7650	12
1046	4	7952	15	7953	7	7956	32	7957	56	7962	32	7963	25	7964	39	7969	33	7970	33
1047	26	7977	5	7978	20	7979	41	7980	2	7983	32	7985	24	7991	11	7992	22	8284	8
1048	12	8246	31	8247	15	8248	80	8249	8	8292	22	8293	10	8295	59	8300	32	8301	14
1049	32	8314	23	8315	31	8321	17	8322	42	8323	14	8517	32	8619	64	8620	32	8623	32
1050	64	8631	32	8642	32	8645	32	8651	22	8652	44	8654	22	8945	32	8950	38	8951	32
1051	20	8954	14	8955	2	8956	7	8957	68	8958	10	8959	5	8960	10	8961	10	8962	22

FIGURE II.4 - SAMPLE PRINTOUT FROM RSS7

(GROSS) GRID PARAMETERS; RADAR AT COL= 781 ROW= 650
 BEAM DISTANCE (RANGE)= 746 GRID ELEMENTS
 INITIAL SWEEP ANGLE OFFSET= 0.0 DEGREES
 RLMS6 SUCCESSFUL END

FIGURE II.5 - SAMPLE PRINTOUT FROM RSS8

7.3 Output

The output file from RSS8 consists of $360 \cdot \text{IFREQ}$ records of 4000 words each. The file is sequential in nature with the records being ordered by their corresponding angle variable θ i.e. the record for the scan line at $\theta = 0^\circ$ is the first one on the file while that for $\theta = 360^\circ$ is the last one.

The first 2000 words contain the intensity-of-return values for each $4, 0 < r \leq R$. Clearly, if $R < 2000$ the remaining words are blank. Words numbered $2000 + I, 1 \leq I \leq 2000$, contain the corresponding terrain elevation values. For example, if $\text{IFREQ} = 2$, then the fourth record has the following significance.

- A) It corresponds to $\theta = 4/\text{IFREQ} = 2^\circ$
- B) The I^{th} word and the $I + 2000^{\text{th}}$ word respectively contain the strength of return and the terrain elevation for the point:

$$X_p = X_T + I \cdot \text{COS} 2^\circ$$

$$Y_p = Y_T + I \cdot \text{SIN} 2^\circ$$

The printout from RSS8 is shown in Figure II.5 and is self-explanatory.

7.4 Timing and Cost

Program RSS8 executes in approximately 1796 cp seconds. Run cost is approximately 390 dollars.

8. Program RSS9

8.1 Input

Program RSS9 requires the output file from RSS8 and the parameter file from RSS7, the two word disc file from RSS2, and a one card input containing the radar altitude.

8.2 Description of Processing

RSS9 processes the data base to take into account certain geometrical effects required to make the final image similar to that which may be expected from a real radar. Prior to RSS9 processing, the only radar return strengths included in the data base are certain intrinsic returns assigned to the planimetry strips on the basis of feature code in RSS8. All of the background ("between" the scan lines) has been assigned the same return intensity and this is clearly inaccurate because it fails to take into account the ground topography. RSS9 assigns a radar return strength to every resolution element within 20 nautical miles of the target location based on the detailed structure of the earth's surface in the area under consideration.

Three specific effects are considered. The first is the Lambert's Law correction and is illustrated in Figure II.6. The mathematical statement of this law is that the return from any given point on the ground is reduced by a factor $\cos\theta_L$ where θ_L is the angle between the incident radar

beam and the normal to the terrain at the point of interest. This is to say, if I is the intrinsic intensity of the background or of the planimetry feature located at a given point, then the actual radar return intensity is given by:

$$I_r = I * \cos\theta_L$$

The implementation of this effect in RSS9 is quite straightforward. For each value of r , the slope of the line through the points $r-1$ and $r+1$ is calculated from the corresponding terrain elevation values thus yielding the angle θ_t . The vector perpendicular to this line defines the normal to the surface at r . The declination angle of the radar beam θ_D can be calculated from r , the terrain elevation at r and the radar altitude. Using these angles, the angle θ_L can be determined from elementary trigonometry.

A second effect taken into account is that of shadowing. The pertinent geometric considerations are illustrated in Figure II.7. The nature of the effect is simply that points on the ground may be in the shadow of terrain peaks lying between the radar and the ground point of interest. Such points will be invisible to the radar and must therefore be assigned a zero intensity-of-return.

The third radar effect that RSS9 handles is the altitude layover effect. This effect shifts the location of the terrain. The length and direction of the shifting of each processed point of the terrain depends on the height of that point. This effect is implemented by considering each point R along a radial line and computing a new altitude layover point R_1 . Given (1) the distance of the point (R) away from the target point along a radial line, (2) the height of the radar above sea level (A), and (3) the elevation of the point R above sea level (E); the distance (D) from the radar to the elevated point along the radial can be computed as follows:

$$D = \sqrt{(A-E)^2 + R^2}$$

Using a principle of elementary trigonometry, we know that a tangent line drawn the length of the elevation of point R to some point R_1 at target level along the radial line yields a distance D_1 equal in length to distance D . The point R_1 can be computed similarly to the above equation. Having computed $D=D_1$, and given the radar altitude above target level (ALT), the point R_1 computed at target level is as follows:

$$R_1 = \sqrt{ALT^2 + (A-E)^2 + R^2}$$

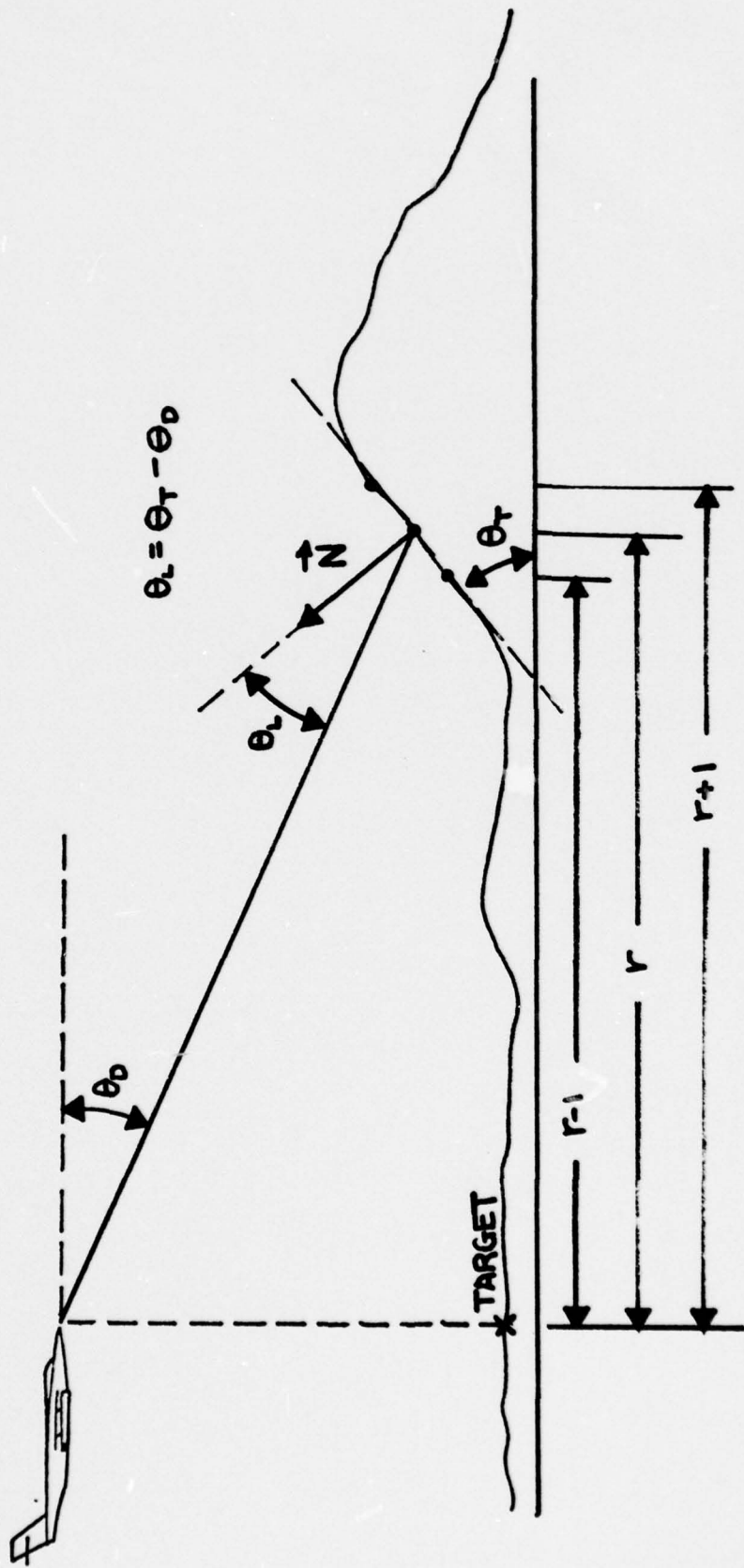

FIGURE II.6 - DEFINITIONS OF LAMBERT'S LAW QUANTITIES

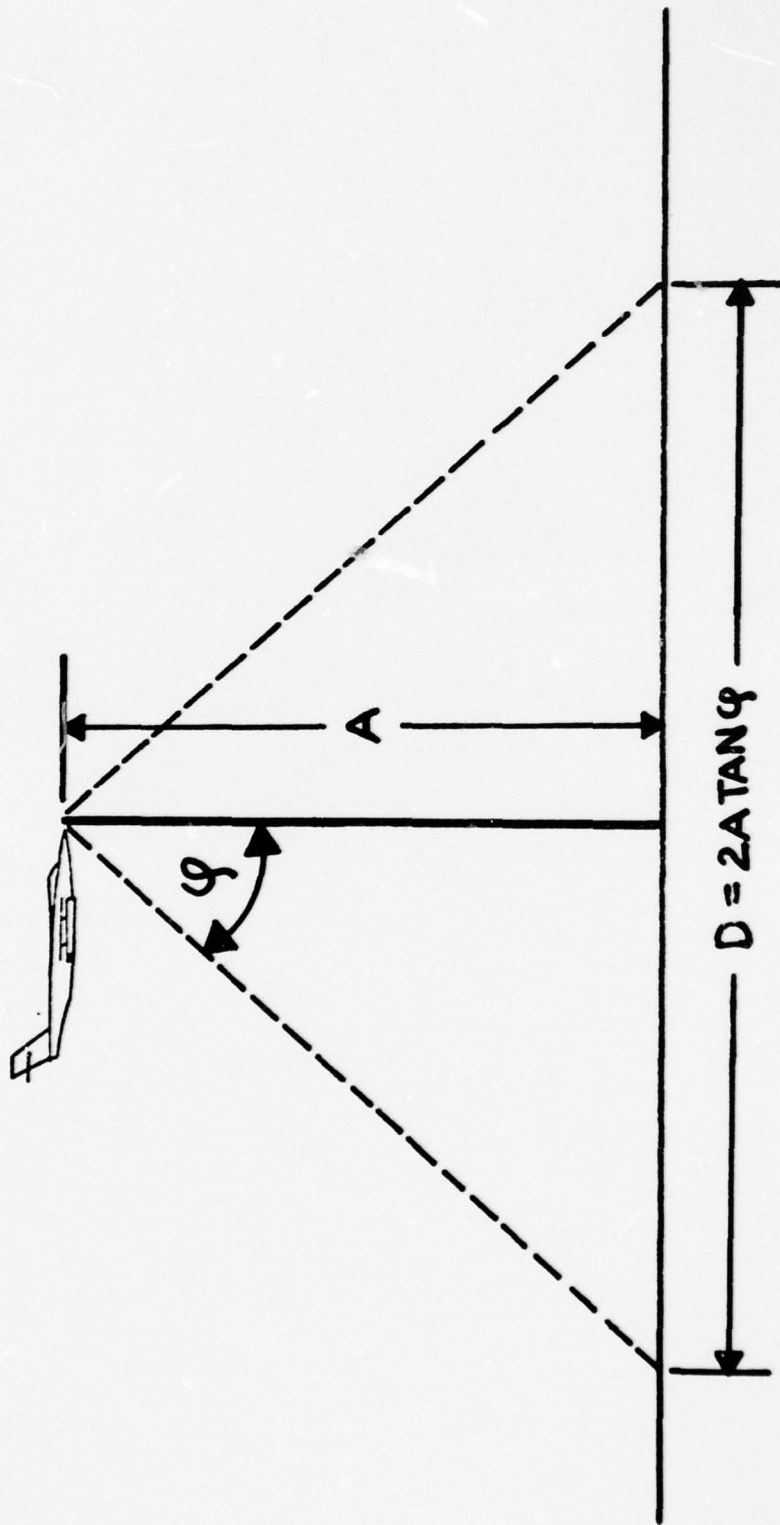

FIGURE II.8 - RADAR GROUND COVERAGE AS A FUNCTION OF ALTITUDE AND APERTURE

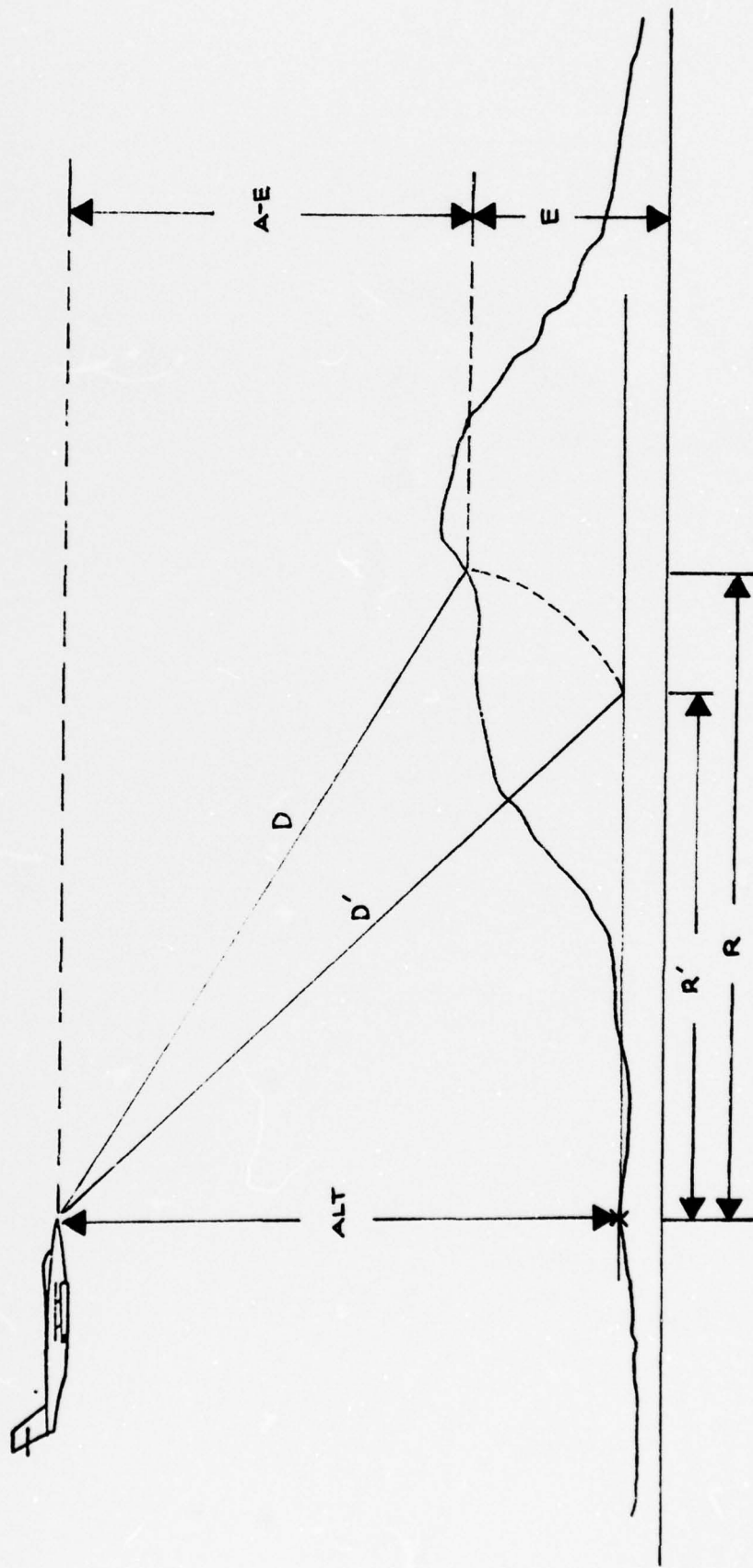

FIGURE II.9 - ILLUSTRATION OF THE ALTITUDE LAYOVER EFFECT

In addition to the three radar effects listed above, RSS9 also scales the scan lines to insure that all generated radar scenes are the same size. The need for such an operation is illustrated in Figure II.8., and is due to the fact that with a fixed radar aperture the ground distance covered by the radar will be the function of the altitude of the radar. Since we will associate one resolution element with one pixel on the DICOMED display, a smaller ground range will result in a progressively smaller display. Subroutine SIZE within RSS9 therefore expands or condenses the image by a factor equal to:

$$F = 1000/\text{NO. OF RESOLUTION ELEMENTS IN THE GROUND RANGE}$$

where we have chosen 1000 resolution elements (which is equivalent to 19.194 nautical miles for a radar located 32000 feet above ground level) as our desired image size. This is done prior to processing by subroutine LAMBERT which includes the radar effects listed above. SIZE simply assigns the elevation and radar return for distance r to distance $F*r$. For points between $F*r$ and $F*(r+1)$, return intensities are set equal to the background value and elevations are computed by linear interpolation.

8.3 Output

The radial sweep-line format of the data in RSS9 is quite suited to the task of incorporating radar effects since such effects are functions of the radial distance. However, for purposes of display on the DICOMED plotter, the image information must be in a raster format. As a preliminary to this raster conversion, RSS9 outputs the data as a large number of small records, each corresponding to a single point on the image. This is done in subroutine REFMT. Each record contains the following information:

WORD1	Number containing encoded (X,Y) coordinate information
WORD2	Intensity value from 0-63. Here intensity zero corresponds to maximum radar return (white) while a 63 corresponds to zero return. This system is the same as used on the DICOMED plotter.

This data is written to four files, each of which contains approximately 1/4 of the image. This is done to speed up the sorting of the points required to order them for raster plotting.

The printout from RSS9 is shown in Figure II.10. The input statistics indicate the distribution of color codes as outputted by RSS8. In the case presented here, a color code of 2 was used for the background.

8.4 Timing and Cost

RSS9 requires approximately 1009 cp seconds and 6 minutes wall clock time for execution. Run cost is approximately 133 dollars.

RLMS9 SUCCESSFUL END, DISPLAY FILE COMPLETE
INPUT STATISTICS

133075 PIXELS WITH COLOR CODE 2
649 PIXELS WITH COLOR CODE 10
162 PIXELS WITH COLOR CODE 12
394 PIXELS WITH COLOR CODE 15

OUTPUT STATISTICS

9 PIXELS WITH COLOR CODE 8
16 PIXELS WITH COLOR CODE 9
29 PIXELS WITH COLOR CODE 10
28 PIXELS WITH COLOR CODE 11
60 PIXELS WITH COLOR CODE 12
32 PIXELS WITH COLOR CODE 13
49 PIXELS WITH COLOR CODE 14
62 PIXELS WITH COLOR CODE 15
73 PIXELS WITH COLOR CODE 16
80 PIXELS WITH COLOR CODE 17
85 PIXELS WITH COLOR CODE 18
96 PIXELS WITH COLOR CODE 19
94 PIXELS WITH COLOR CODE 20
149 PIXELS WITH COLOR CODE 21
165 PIXELS WITH COLOR CODE 22
185 PIXELS WITH COLOR CODE 23
239 PIXELS WITH COLOR CODE 24
279 PIXELS WITH COLOR CODE 25
316 PIXELS WITH COLOR CODE 26
389 PIXELS WITH COLOR CODE 27
502 PIXELS WITH COLOR CODE 28
558 PIXELS WITH COLOR CODE 29
687 PIXELS WITH COLOR CODE 30
973 PIXELS WITH COLOR CODE 31
1407 PIXELS WITH COLOR CODE 32
2326 PIXELS WITH COLOR CODE 33
3699 PIXELS WITH COLOR CODE 34
4843 PIXELS WITH COLOR CODE 35
5932 PIXELS WITH COLOR CODE 36
9322 PIXELS WITH COLOR CODE 37
13391 PIXELS WITH COLOR CODE 38
21559 PIXELS WITH COLOR CODE 39
30185 PIXELS WITH COLOR CODE 40
15275 PIXELS WITH COLOR CODE 41
7029 PIXELS WITH COLOR CODE 42
3936 PIXELS WITH COLOR CODE 43
2418 PIXELS WITH COLOR CODE 44
1632 PIXELS WITH COLOR CODE 45
1029 PIXELS WITH COLOR CODE 46
790 PIXELS WITH COLOR CODE 47
594 PIXELS WITH COLOR CODE 48
437 PIXELS WITH COLOR CODE 49
359 PIXELS WITH COLOR CODE 50
331 PIXELS WITH COLOR CODE 51
308 PIXELS WITH COLOR CODE 52
569 PIXELS WITH COLOR CODE 53
383 PIXELS WITH COLOR CODE 54
207 PIXELS WITH COLOR CODE 55
235 PIXELS WITH COLOR CODE 56
161 PIXELS WITH COLOR CODE 57
149 PIXELS WITH COLOR CODE 58
102 PIXELS WITH COLOR CODE 59
105 PIXELS WITH COLOR CODE 60
106 PIXELS WITH COLOR CODE 61
441 PIXELS WITH COLOR CODE 62
970 PIXELS WITH COLOR CODE 63
924 PIXELS WERE ASSIGNED TO THE SHADOW

FIGURE II.10 - SAMPLE PRINTOUT FROM RSS9

9. Program SORT

This program uses the CDC SORT/MERGE package to combine the four output files from RSS9 into a single file ordered as follows: the records are sorted first by Y and then by X. Because the X,Y information for each point is encoded into a single number, this can be accomplished via a single level sort. The procedure followed is to individually sort each of the files and then merge them into one large, ordered file. The code for the SORT is:

```
SORT, VAR=DISC
BYTESIZE,60
FILE,SORT=TAPEIN,OUTPUT=TAPEOUT
FIELD,ROW(1.1,1,INTEGER)
KEY,ROW(A)
END
```

The merge is accomplished in a similar fashion.

With an angular increment of $1/2^\circ$ between radial scan lines, the description of the radar image requires 1,440,000 points (records). The sorting of this amount of information is a time-consuming process as is evidenced by a SORT running time of 1745 cp seconds (about 2 hours wall clock time) and a run cost of around 347 dollars.

10. Program RSS10

10.1

RSS10 uses the sorted data from SORT to format a plot tape for the DICOMED.

10.2

The DICOMED screen consists of a 2048 X 2048 grid with the intensity of each grid element being specified by a 6-bit color code. In the mode of operation presently being employed, plotting is done sequentially in horizontal rows beginning at the top of the screen. Therefore, in order to describe a picture it is necessary to format 2048 records of 205 words each, e.g., one record for each row consisting of 2048 6-bit color codes packed 10 per word.

The present image format calls for the radar scene to be displayed as a circle of radius 1000 pixels. Therefore, the first step is to generate 11 blank (all white) records to describe the top margin of the picture. The actual image begins in row 12.

For each of the 2000 records containing image information, those pixels actually lying in the radar-scene circle are colored black. As should be evident, not all points within the circle will contain image information - only the points on the radial scan lines contain data and if an angular spacing of $1/2^\circ$ is used, these comprise only about 29% of the total number of possible image points. Therefore, the choice of the "fill" color is important and black is chosen since it will not introduce any correlation error when the generated image is compared to the more dense output of a real radar.

The information from the input file is then written over the fill color. Since the information is sorted, taking the points in the order they appear permits the records to be filled sequentially from left to right, with a change in Y signalling the end of a given line. When the radar circle is completed, a bottom margin of 11 blank records is written to the plot tape.

The program also places four fiducial marks located at each edge of the image. A small cross-mark is also placed at the center of the image to mark the target location.

10.3 Output

RSS10 outputs the DICOMED plot tape which marks the end of the simulation process. The format of the image generated by this tape is presented in Figure II.11.

10.4 Timing and Cost

RSS10 requires approximately 506 cp seconds execution time and about 20 minutes wall clock time. Run cost may be expected to be in the neighborhood of fifty-four dollars.

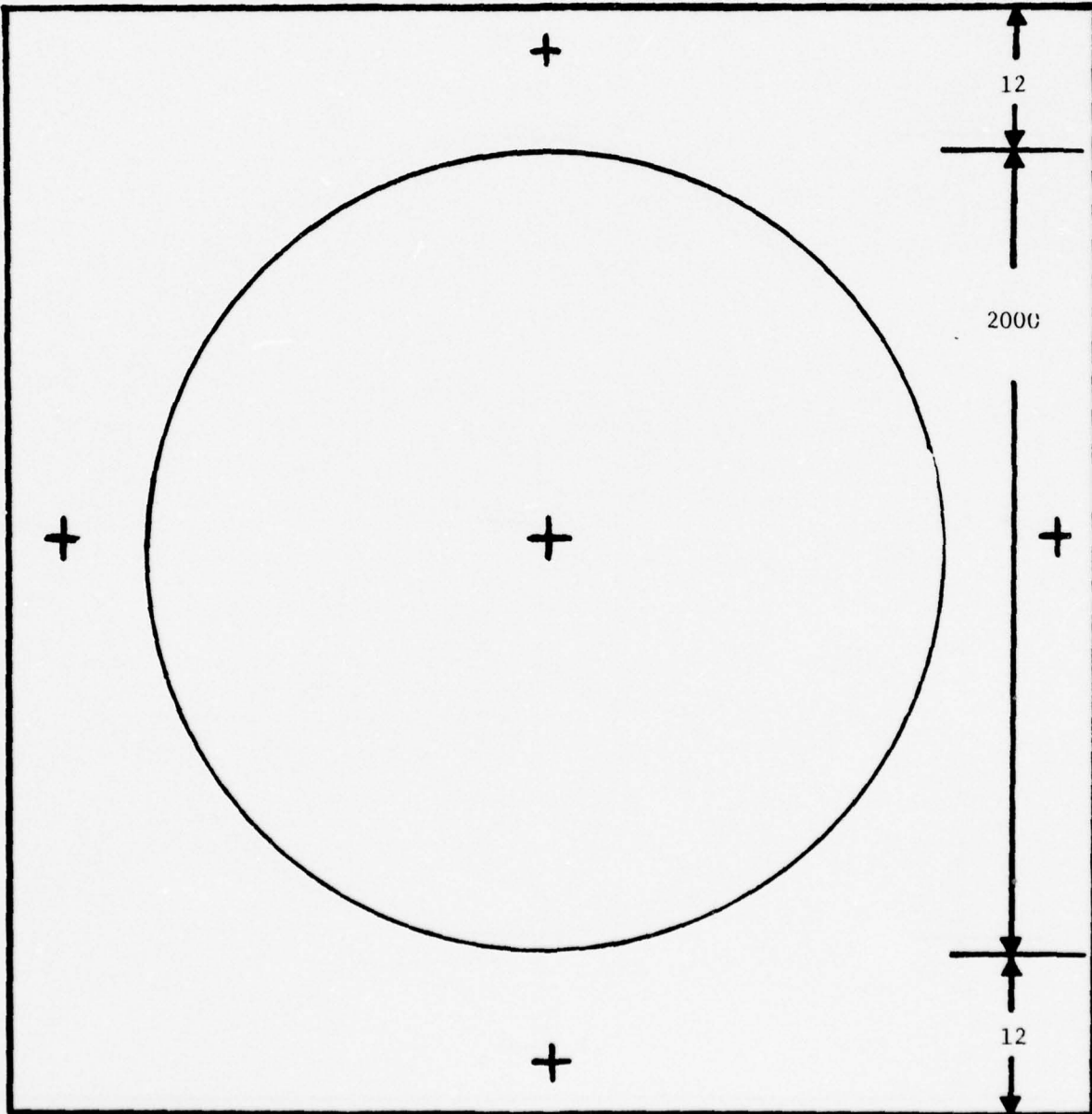

FIGURE II.11 - FINAL IMAGE FORMAT

III. OPERATING INSTRUCTIONS

It is the purpose of this chapter to present the deck structures required to operate the DRLMS on ETL's CDC 6400 under SCOPE 3.4. As is evident from the preceding discussions, this system consists of a large number of independent programs. This configuration is due to the fact that the DRLMS was originally written for a minicomputer and so its structure reflects the size limitations of the associated hardware. In order to simplify and speed up processing, it is recommended that the system be run as two dependent strings of programs. The first string consists of programs RLMS1 through RLMS6 and may be viewed as a data base preparation subsystem. Programs RLMS7 through RLMS10 may then be run as a dependent string to create the radar scene for the desired altitude.

We first present the deck structures for the dependent string RLMS1 through RLMS6. In all that follows, the permanent file organization is such that no file is ever purged. The user may wish to conserve space by altering this procedure. Unit numbers must be assigned as indicated although permanent file names and tape VSN's may be chosen as desired. We emphasize that the method to be presented is only one possibility and that disc storage limitations may necessitate the use of more space-effective procedures.

RSS1: Here, tape 7 is the Gerber plot tape containing the planimetry data.

```
ETRS1,T200,NT1,DABOO.
TASK(TNET***** ,PW***** ,TRTS)NAME
FTN.
MOUNT(VSN=PK0007,SN=BZRADAR)
REQUEST,TAPE8,*PF,SN=BZRADAR.
REQUEST,TAPE7,NT,HD,S,US,NORING,VSN=EOO***.
FILE(TAPE7,MRL=1960,MBL=1980,BFS=200)
REWIND(TAPE7,TAPE8)
LDSET,FILES=TAPE7.
LGO.
CATALOG(TAPE8,PFN1,SN=BZRADAR,ID=ET***** ,CY=01,AC=RLMS1,RP=999
TRANSF(ETRS2,ETRS3,ETRS5,ETRS6,ETRS7,ETRS8)
789
FORTRAN DECK
789
DATA CARD FOR X,Y OFFSETS
6789
```

RSS2:

```
ETRS2,CM200000,T3000,DABO1.
TASK(TNET***** ,PW***** ,TRTS)NAME
FTN.
MOUNT(VSN=PK0007,SN=BZRADAR)
ATTACH(TAPE8,PFN1,SN=BZRADAR,ID=ET***** ,CY=01)
REQUEST,TAPE9,*PF,SN=BZRADAR
REQUEST,TAPE20,*PF,SN=BZRADAR
LGO.
```

CATALOG (TAPE9, PFN3, SN=BZRADAR, ID=ET*****, CY=02, AC=RLMS2, RP=999)
CATALOG (TAPE20, PFN20, SN=BZRADAR, ID=ET*****, CY=1, AC=2OUT, RP=999)
TRANSF (ETRS3, ETRS5, ETRS6, ETRS7, ETRS8)
789
FORTRAN DECK
789
DATA CARD FOR MAP SCALE PLANIMETRY RESOLUTION AND REGION SIZE
6789

RSS3: RECALL THAT RSS4 IS THE SORT ROUTINE IN RSS3.

ETRS3, T1000, DAB02.
TASK (TNET*****, PW*****, TRTS) NAME
FTN.
MOUNT (VSN=PK0007, SN=BZRADAR)
ATTACH (TAPE7, PFN3, SN=BZRADAR, ID=ET*****, CY=02)
ATTACH (TAPE20, PFN2, SN=BZRADAR, ID=ET*****, CY=01)
REQUEST, TAPE2, *PF, SN=BZRADAR
LGO.
FILE, TAPE1, BT=C, RT=Z, FL=89
FILE, TAPE2, BT=C, RT=Z, FL=89, CM=YES
SORTMRG.
CATALOG (TAPE2, PFN4, ID=ET*****, CY=03, AC=RLMS3, RP=999)
TRANSF (ETRS5, ETRS6, ETRS7, ETRS8)
789
FORTRAN DECK FOR RLMS3
789
SORT/MERGE DIRECTIVES
6789

RSS5:

ETRS5, T1000, DAB3.
TASK (TNET*****, PW*****, TRTS) NAME
FTN.
MOUNT (VSN=PK0007, SN=BZRADAR)
ATTACH (TAPE7, PFN4, SN=BZRADAR, ID=ET*****, CY=03)
ATTACH (TAPE20, PFN2, SN=BZRADAR, ID=ET*****, CY=01)
FILE, TAPE7, BT=C, RT=Z, FL=89.
REQUEST, TAPE10, *PF, SN=BZRADAR.
LDSET (FILES=TAPE7)
LGO.
CATALOG (TAPE10, PFN6, SN=BZRADAR, ID=ET*****, CY=05, AC=RLMS5, RP=999)
TRANSF (ETSM6, ETRS7, ETRS8)
789
FORTRAN DECK
6789

RSS6: Here, TAPE8 is the UNAMACE elevation tape.

```
ETRS6, T2000, CM230000, NT1, DAB04.  
TASK (TNET***** , PW***** , TRTS) NAME  
FTN.  
MOUNT (VSN=PK0007, SN=BZRADAR)  
ATTACH (TAPE20, PFN2, SN=BZRADAR, ID=ET***** , CY=01)  
REQUEST (TAPE8, NT, HD, S, NORING=VSN=E00****)  
REQUEST (TAPE9, *PF, SN=BZRADAR)  
LGO.  
CATALOG (TAPE9, PFN7, SN=BZRADAR, ID=ET***** , CY=04, AC=PROG6, RP=999)  
789  
FORTRAN DECK  
6789
```

This completes the data base preparation stage of the DRLMS. We emphasize again that the preceeding programs need be run only once for each target area. We now proceed to the image preparation stage consisting of programs RSS7 through RSS10.

RSS7:

```
ETRS7, T700, DAB05  
TASK (TNET***** , PW***** , TRTS) NAME  
FTN.  
MOUNT (VSN=PK0007, SN=BZRADAR)  
REQUEST, TAPE6, *PF, SN=BZRADAR.  
REQUEST, TAPE12, *PF, SN=BZRADAR.  
ATTACH (TAPE3, PFN6, SN=BZRADAR, ID=ET***** , CY=05)  
ATTACH (TAPE1, PFN7, SN=BZRADAR, ET***** , CY=04)  
ATTACH (TAPE20, PFN2, SN=BZRADAR, ET***** , CY=01)  
LGO.  
CATALOG (TAPE6, PFN8, SN=BZRADAR, ID=ET***** , CY=04, AC=RLMS7, RP=999)  
CATALOG (TAPE12, PFN9, SN=BZRADAR, ID=ET***** , CY=04, AC=MAPDATA, RP=999)  
TRANSF (ETRS8)  
789  
FORTRAN DECK  
789  
$PARAMS  
DATA CARD  
$END  
6789
```

RSS8:

```
ETRS8, T4500, DAB06  
TASK (TNET***** , PW***** , TRTS) NAME  
FTN.  
MOUNT (VSN=PK0007, SN=BZRADAR)  
ATTACH (TAPE6, PFN8, SN=BZRADAR, ID=ET***** , CY=04)  
ATTACH (TAPE12, PFN9, SN=BZRADAR, ID=ET***** , CY=04)  
ATTACH (TAPE20, PFN2, SN=BZRADAR, ET***** , CY=01)  
REQUEST, TAPE4, *PF, SN=BZRADAR.  
LGO.  
CATALOG (TAPE4, PFN10, SN=BZRADAR, ID=ET***** , CY=32, AC=PROG8, RP=999)  
789  
FORTRAN DECK  
6789
```

RSS9: The following must be run once for each desired radar altitude.
Note that the output of RSS9 is placed on a private pack. This
is due to space limitations on ETL's system disc.

```
ETRS9, T3500, DAB00
TASK (TNET***** ,PW***** ,TRTS) NAME
FTN.
MOUNT (VSN=PK0007, SN=BZRADAR)
ATTACH (TAPE6, PFN8, SN=BZRADAR, ID=ET***** ,CY=04)
ATTACH (TAPE4, PFN10, SN=BZRADAR, ID=ET***** ,CY=32)
ATTACH (TAPE20, PFN2, SN=BZRADAR, ID=ET***** ,CY=01)
REQUEST (TAPE3, *PF, SN=BZRADAR)
REQUEST (TAPE10, *PF, SN=BZRADAR)
REQUEST (TAPE12, *PF, SN=BZRADAR)
REQUEST (TAPE14, *PF, SN=BZRADAR)
FILE (TAPE3, BT=K, RB=31, RT=F, FL=20, MBL=620)
FILE (TAPE10, BT=K, RB=31, RT=F, FL=20, MBL=620)
FILE (TAPE12, BT=K, RB=31, RT=F, FL=20, MBL=620)
FILE (TAPE14, BT=K, RB=31, RT=F, FL=20, MBL=620)
LDSET (FILES=TAPE3/TAPE10/TAPE12/TAPE14)
LGO.
CATALOG (TAPE3, PFNSN, ID=ET***** ,SN=BZRADAR, CY=01, AC=9OUT, RP=999)
CATALOG (TAPE10, PFNSN, ID=ET***** ,SN=BZRADAR, CY=02, AC=9OUT, RP=999)
CATALOG (TAPE12, PFNSN, ID=ET***** ,SN=BZRADAR, CY=03, AC=9OUT, RP=999)
CATALOG (TAPE14, PFNSN, ID=ET***** ,SN=BZRADAR, CY=04, AC=9OUT, RP=999)
TRANSF (ETSORT, ETRS10)
789
FORTRAN DECK
6789
```

ETSORT: Due to space limitations, the SYSTEM/SORT scratch files are
assigned to the private pack. These are denoted by the ZZZZ
prefix.

```
ETSORT, T5000, DAB01.
TASK (TNET***** ,PW***** ,TRTS) NAME
MOUNT (PK0007, SN=BZRADAR)
ATTACH (TAPE3, PFNSN, ID=ET***** ,SN=BZRADAR, CY=01)
ATTACH (TAPE10, PFNSN, ID=ET***** ,SN=BZRADAR, CY=02)
ATTACH (TAPE12, PFNSN, ID=ET***** ,SN=BZRADAR, CY=03)
ATTACH (TAPE14, PFNSN, ID=ET***** ,SN=BZRADAR, CY=04)
REQUEST (ZZZZZ1A, SN=BZRADAR)
REQUEST (ZZZZZ1B, SN=BZRADAR)
REQUEST (ZZZZZ1C, SN=BZRADAR)
REQUEST (ZZZZZ1D, SN=BZRADAR)
REQUEST (ZZZZZ1E, SN=BZRADAR)
REQUEST (ZZZZZ1F, SN=BZRADAR)
REQUEST (TAPE2, SN=BZRADAR)
REQUEST (TAPE11, SN=BZRADAR)
REQUEST (TAPE13, SN=BZRADAR)
REQUEST (TAPE15, SN=BZRADAR)
REQUEST (TAPE27, *PF, SN=BZRADAR)
FILE (TAPE3, BT=K, RB=31, RT=F, FL=20, MBL=620)
FILE (TAPE2, BT=K, RB=31, RT=F, FL=20, MBL=620)
SORTMRG.
```

```

FILE (TAPE10,BT=K, RB= 31 ,RT=F, FL=20, MBL=620)
FILE (TAPE11,BT=K, RB= 31 ,RT=F, FL=20, MBL=620)
SORTMRG.
FILE (TAPE12,BT=K, RB= 31 ,RT=F, FL= 20, MBL=620)
FILE (TAPE13,BT=K, RB= 31 ,RT=F, FL=20, MBL=620)
SOPTMRG.
FILE (TAPE14,BT=K, RB= 31 ,RT=F, FL=20, MBL=620)
FILE (TAPE15,BT=K, RB= 31 ,RT=F, FL=20, MBL=620)
SORTMRG.
FILE (TAPE27,BT=K, RB= 31 ,RT=F, FL=20, MBL=620)
SORTMRG.
CATALOG (TAPE27, FINALE, SN=BZRADAR, ID=ET*****, AC=PLOTPE, RP=999)
TRANSF (ETRS10)
789
SOKT DIRECTIVES FOR FIRST SORT
789
SORT DIRECTIVES FOR SECOND SORT
789
SORT DIRECTIVES FOR THIRD SORT
789
SORT DIRECTIVES FOR FOURTH SORT
789
MERGE DIRECTIVES
6789

```

It should be clear that all four SORT routines are the same except for the file names.

RSS10:

```

ETRS10.11500,TF1,DAB02.
TASK (TNET*****,PW*****,TRTS) NAME
FTN.
MOUNT (PK0007,SN=BZRADAR)
ATTACH (TAPE1,FINALE, ID=ET*****,SN=BZRADAR)
FILE (TAPE1,BT=K, RB= 31 ,RT=F, FL=20, MBL=620)
REQUEST,TAPE3,L,RING,VSN=E00***.
LDSET (FILES=TAPE1)
LGO.
789
FORTRAN DECK
6789

```

The output from RSS10 is the plot tape for the DICOMED.

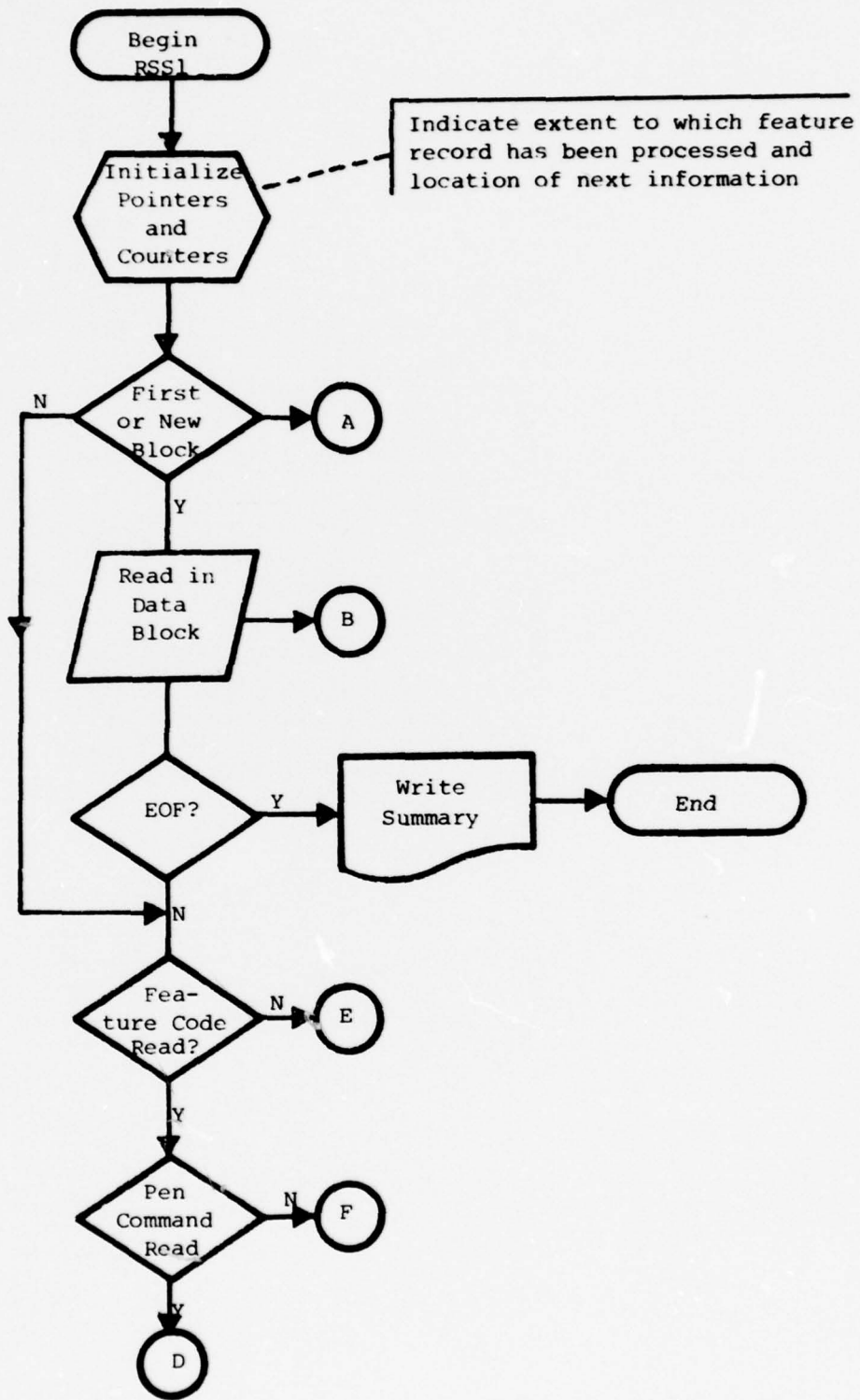

FIGURE IV.1 - PROGRAM RSS1 FLOWCHART
(Page 1 of 4)

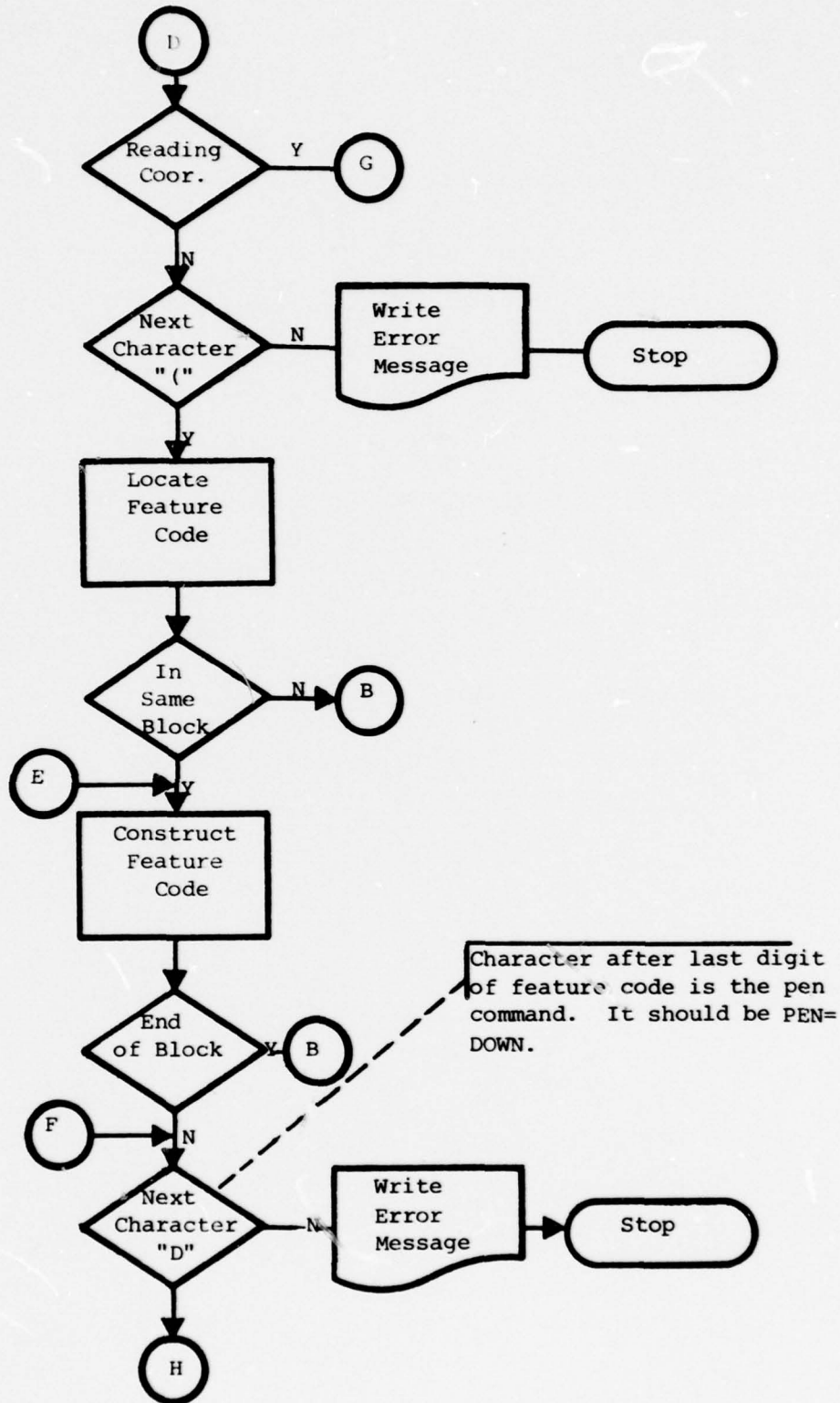

FIGURE IV.1 - PROGRAM RSS1 FLOWCHART
(Page 2 of 4)

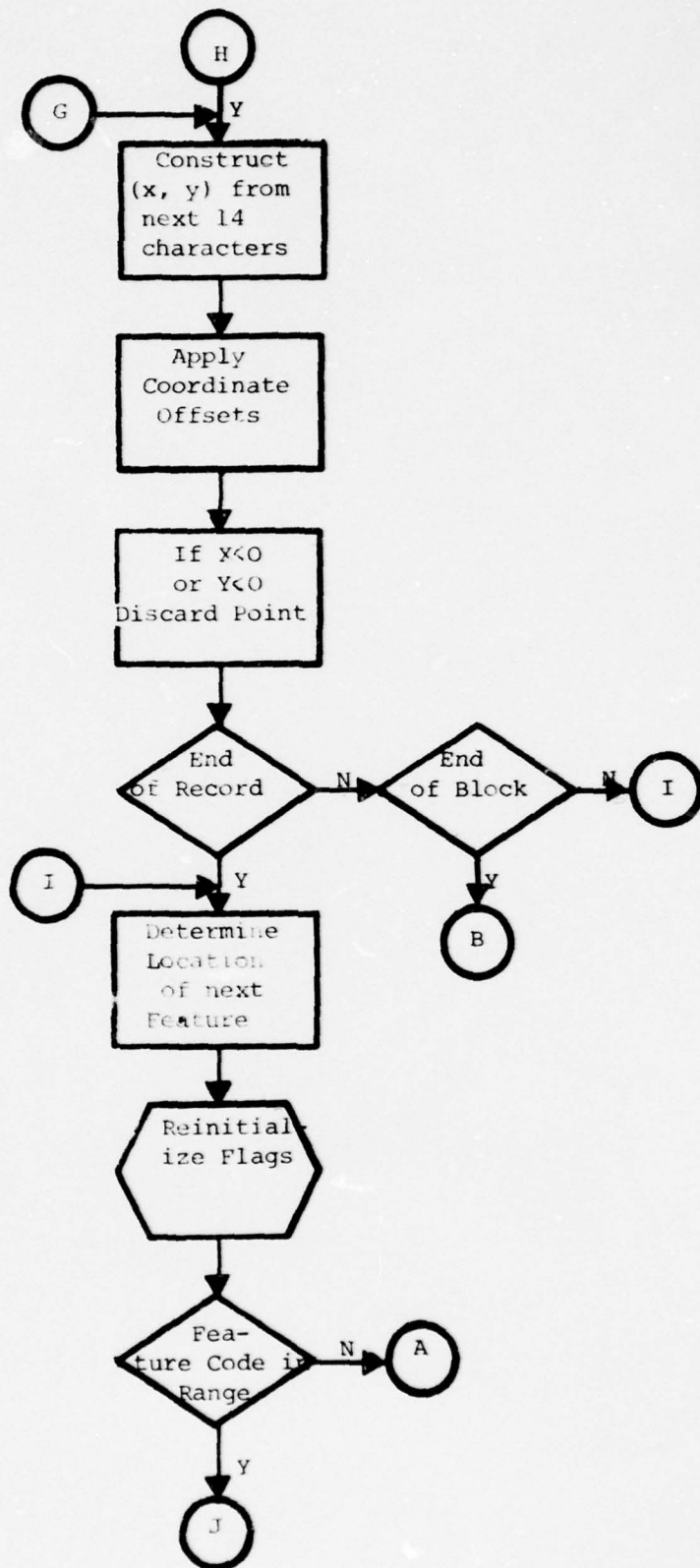

FIGURE IV.1 - PROGRAM RSS1 FLOWCHART
(Page 3 of 4)

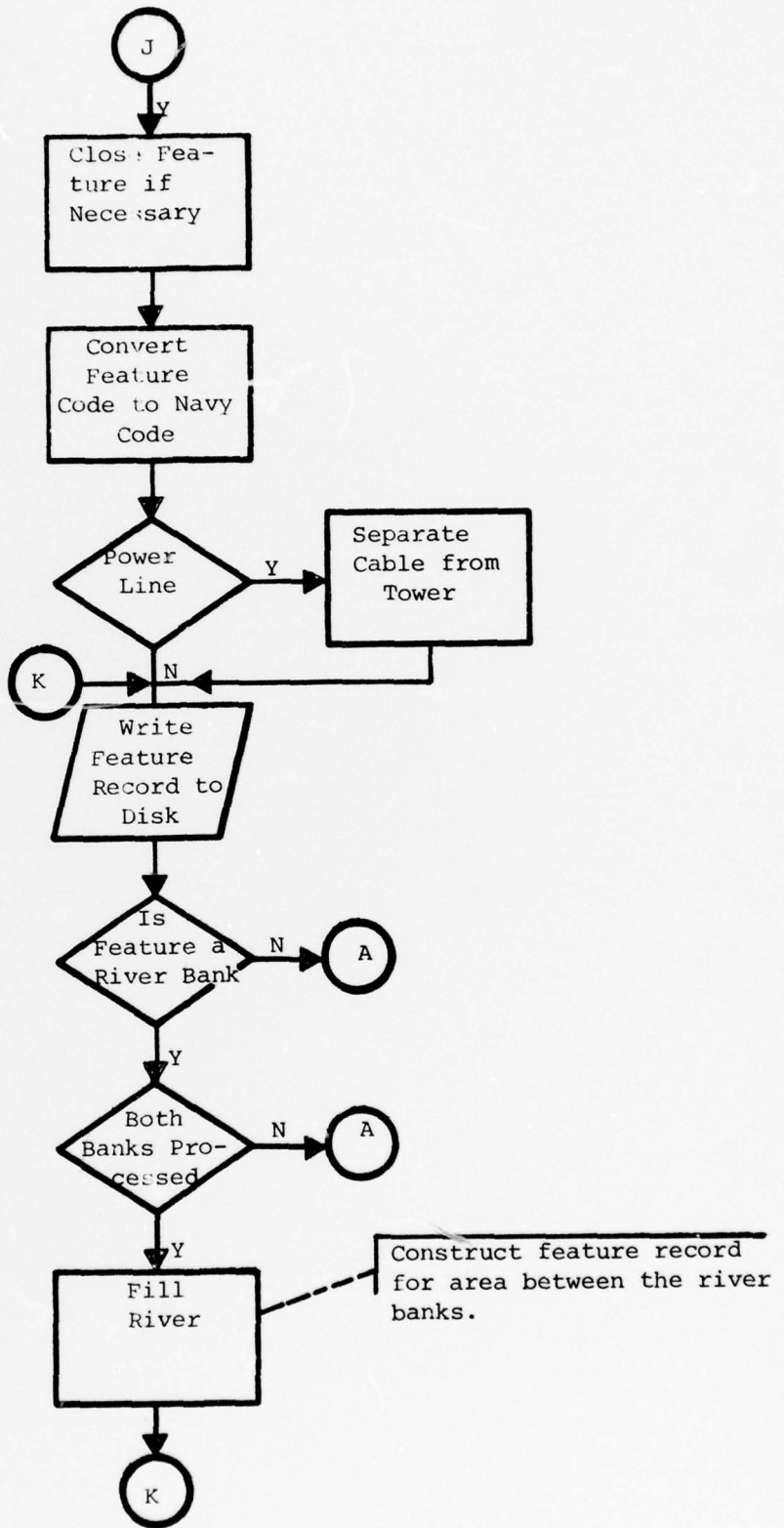

FIGURE IV.1 - PROGRAM RSS1 FLOWCHART
(Page 4 of 4)

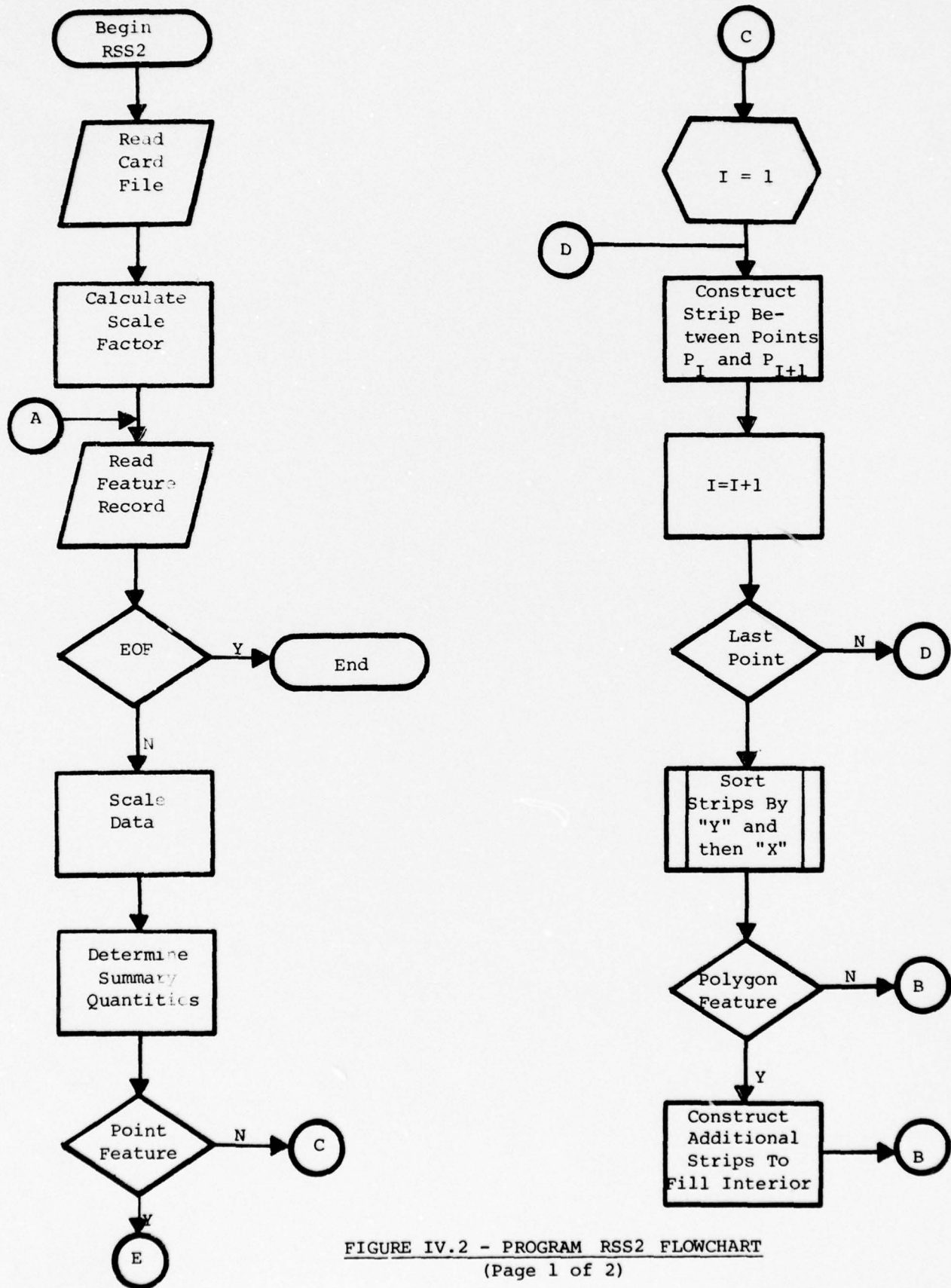

FIGURE IV.2 - PROGRAM RSS2 FLOWCHART
(Page 1 of 2)

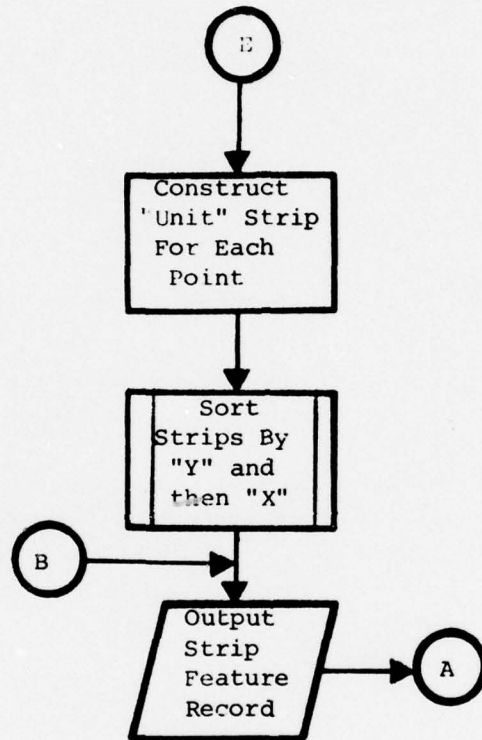

FIGURE IV.2 - PROGRAM RSS2 FLOWCHART
(Page 2 of 2)

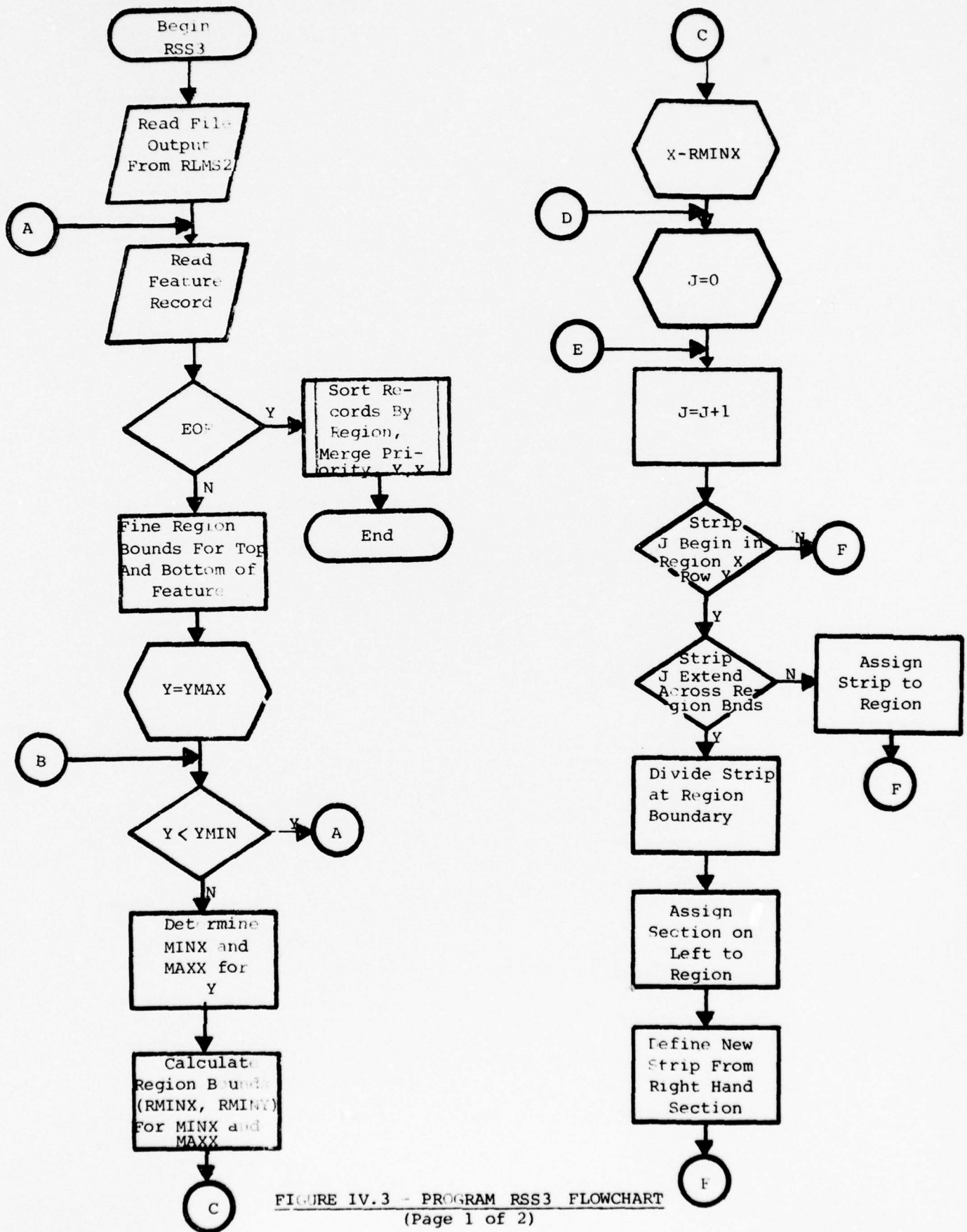

FIGURE IV.3 - PROGRAM RSS3 FLOWCHART
(Page 1 of 2)

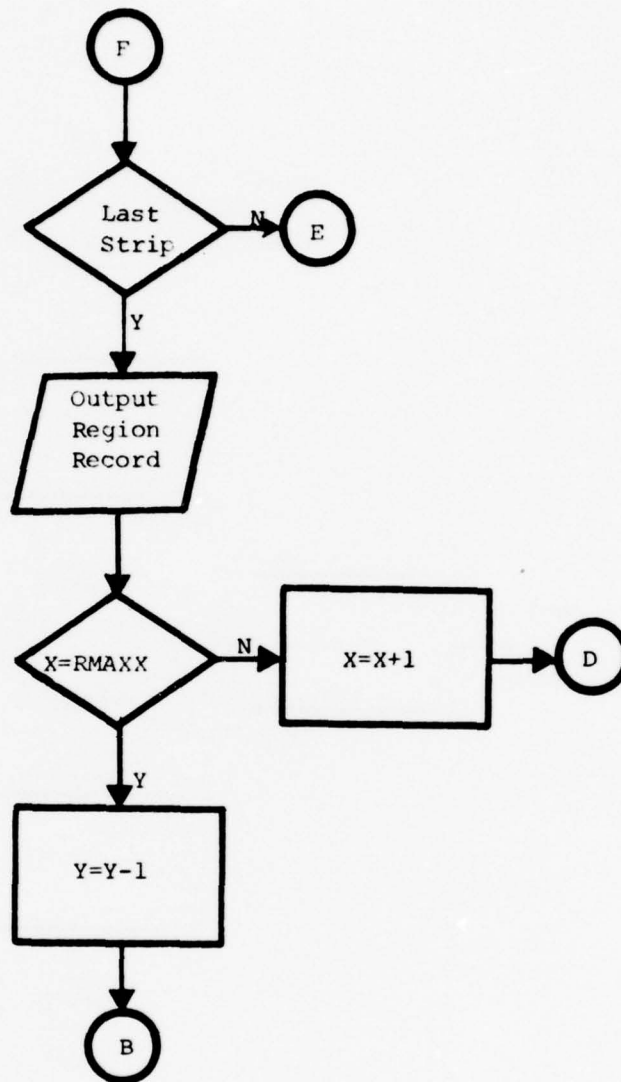

FIGURE IV.3 - PROGRAM RSS3 FLOWCHART
(Page 2 of 2)

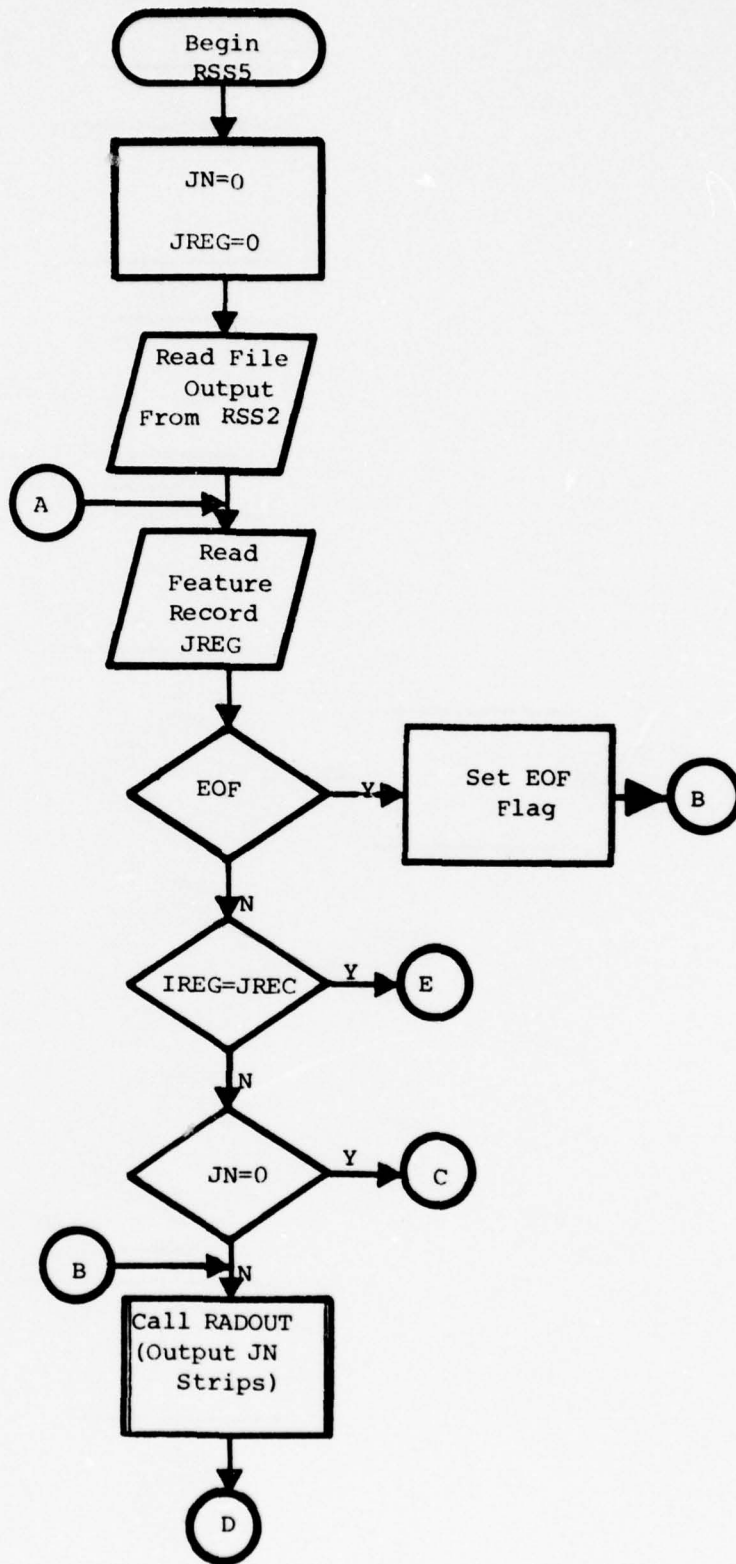

FIGURE IV.4 - PROGRAM RSS5 FLOWCHART
(Page 1 of 4)

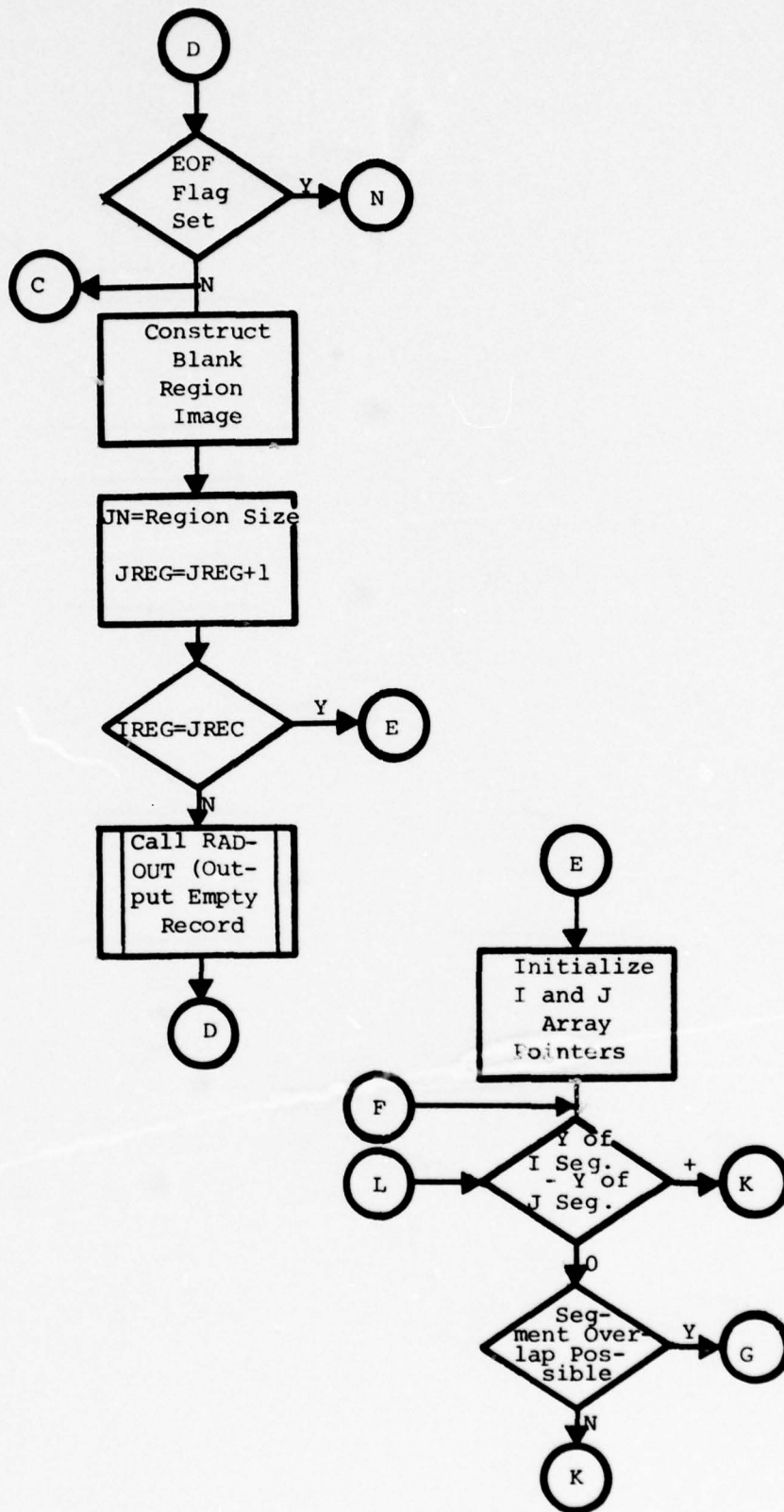

FIGURE IV.4 - PROGRAM RSS5 FLOWCHART
(Page 2 of 4)

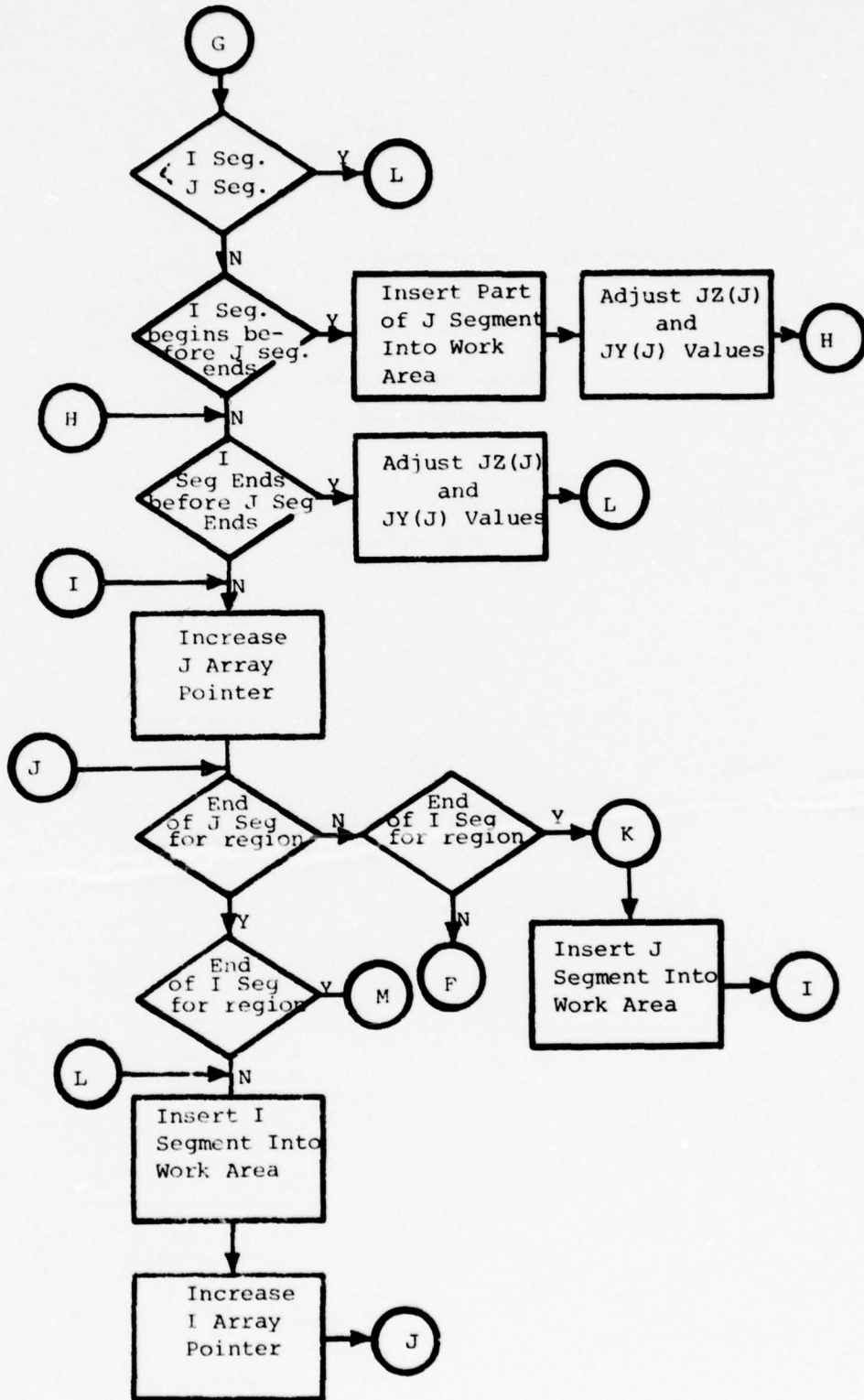

FIGURE IV.4 - PROGRAM RSS5 FLOWCHART
(Page 3 of 4)

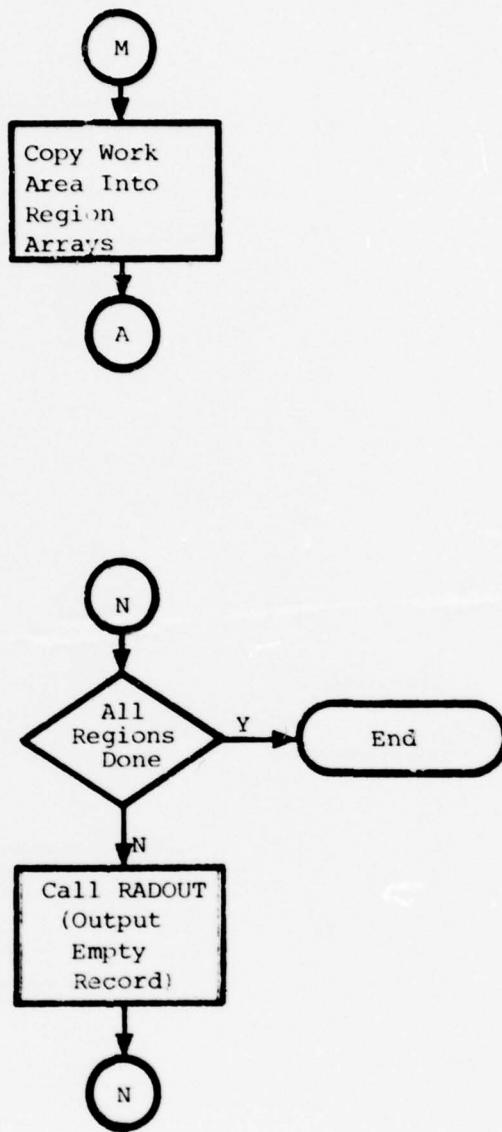

FIGURE IV.4 - PROGRAM RSS5 FLOWCHART
(Page 4 of 4)

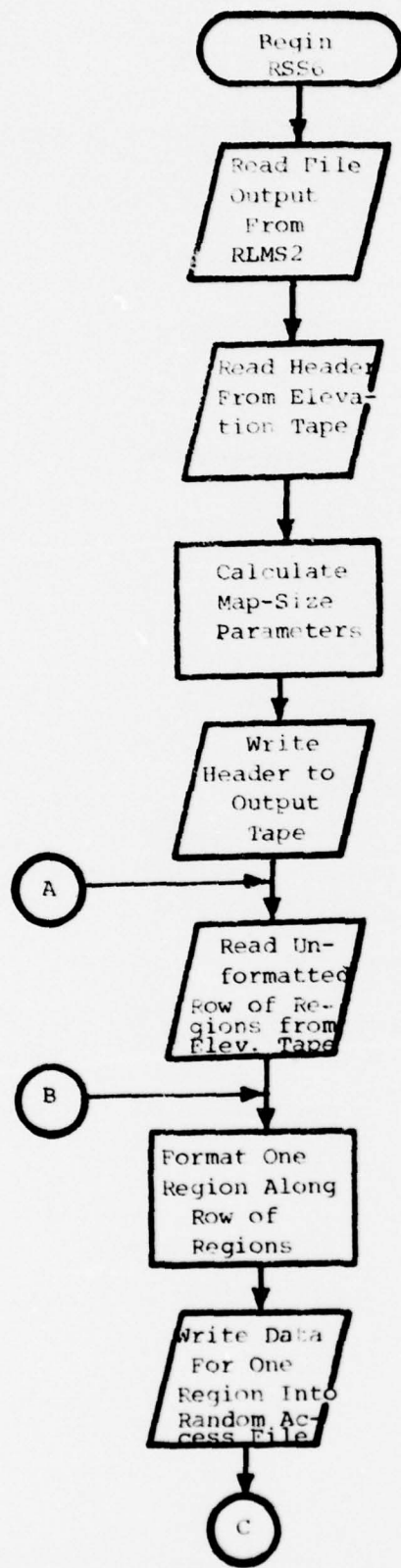

FIGURE IV.5 - PROGRAM RSS6 FLOWCHART
(Page 1 of 2)

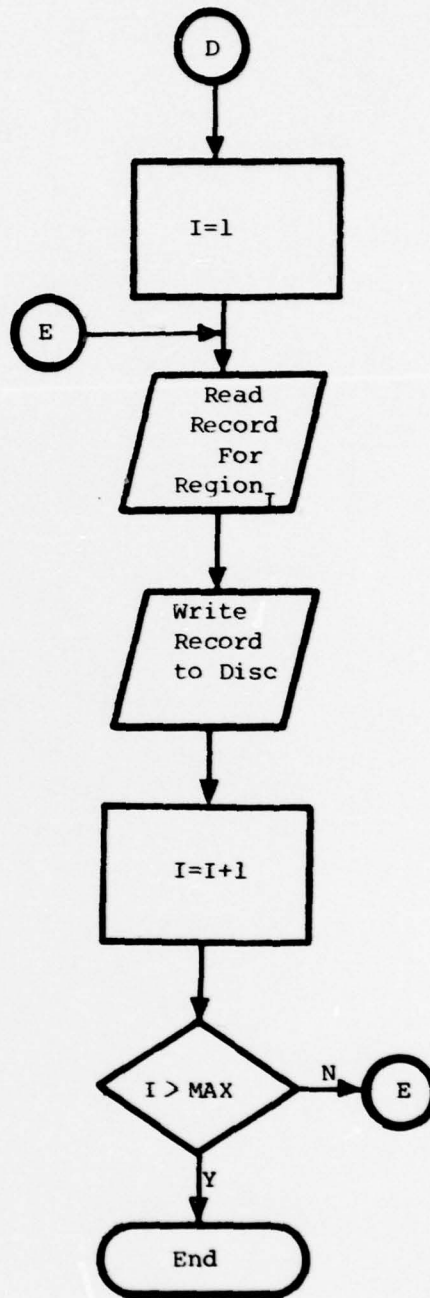
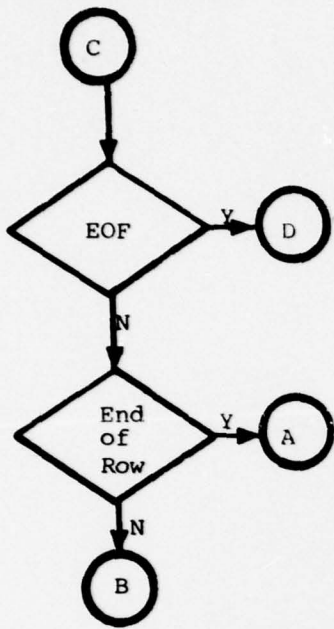

FIGURE IV.5 - PROGRAM RSS6 FLOWCHART
(Page 2 of 2)

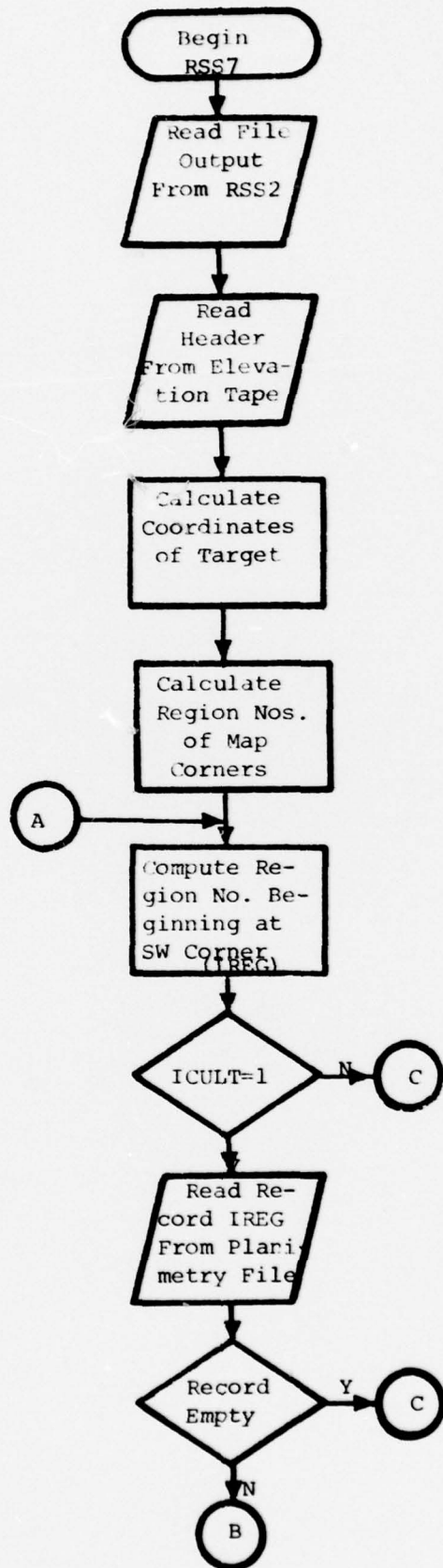

FIGURE IV.6 - PROGRAM RSS7 FLOWCHART
(Page 1 of 2)

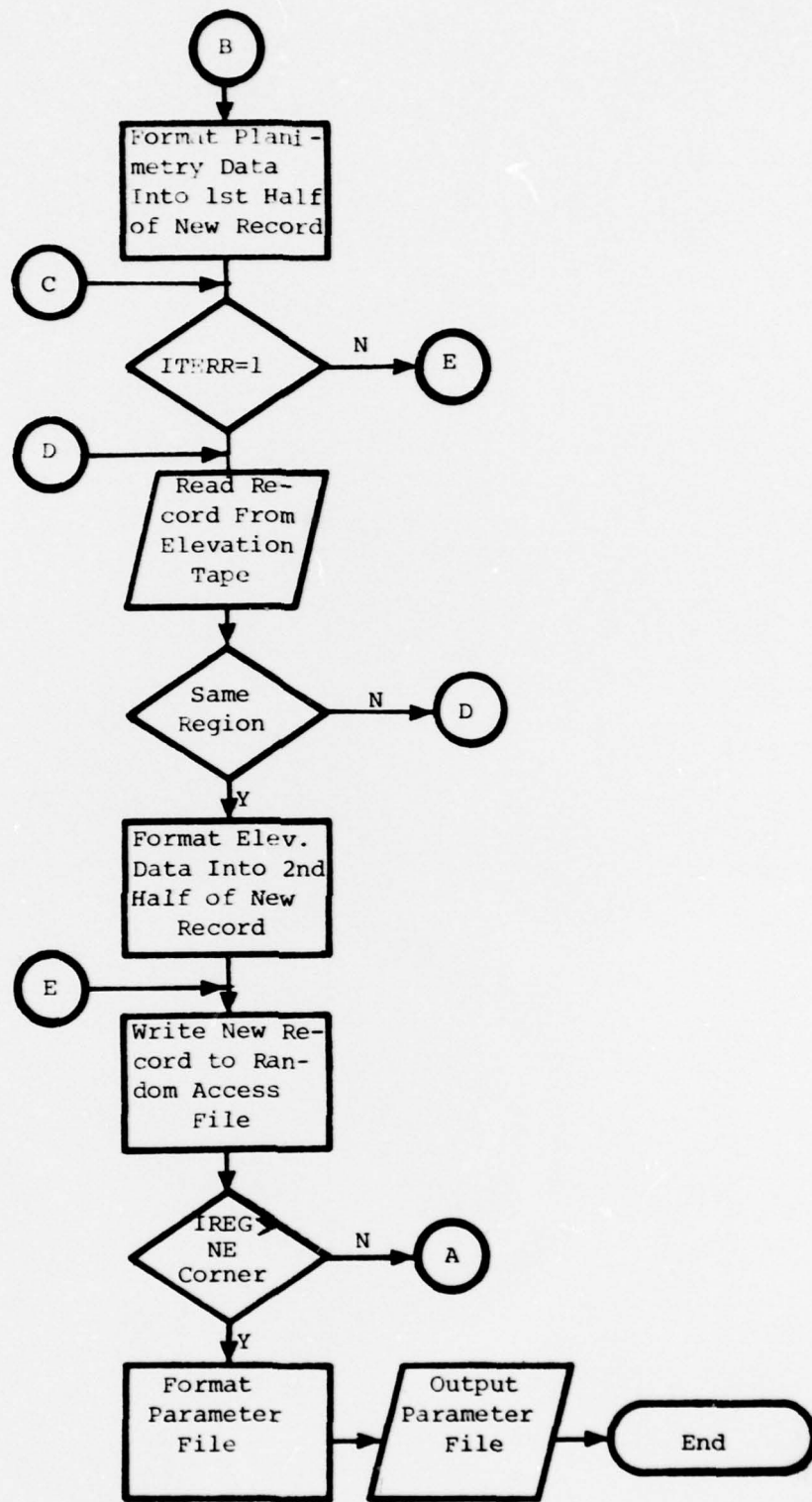

FIGURE IV.6 - PROGRAM RSS7 FLOWCHART
(Page 2 of 2)

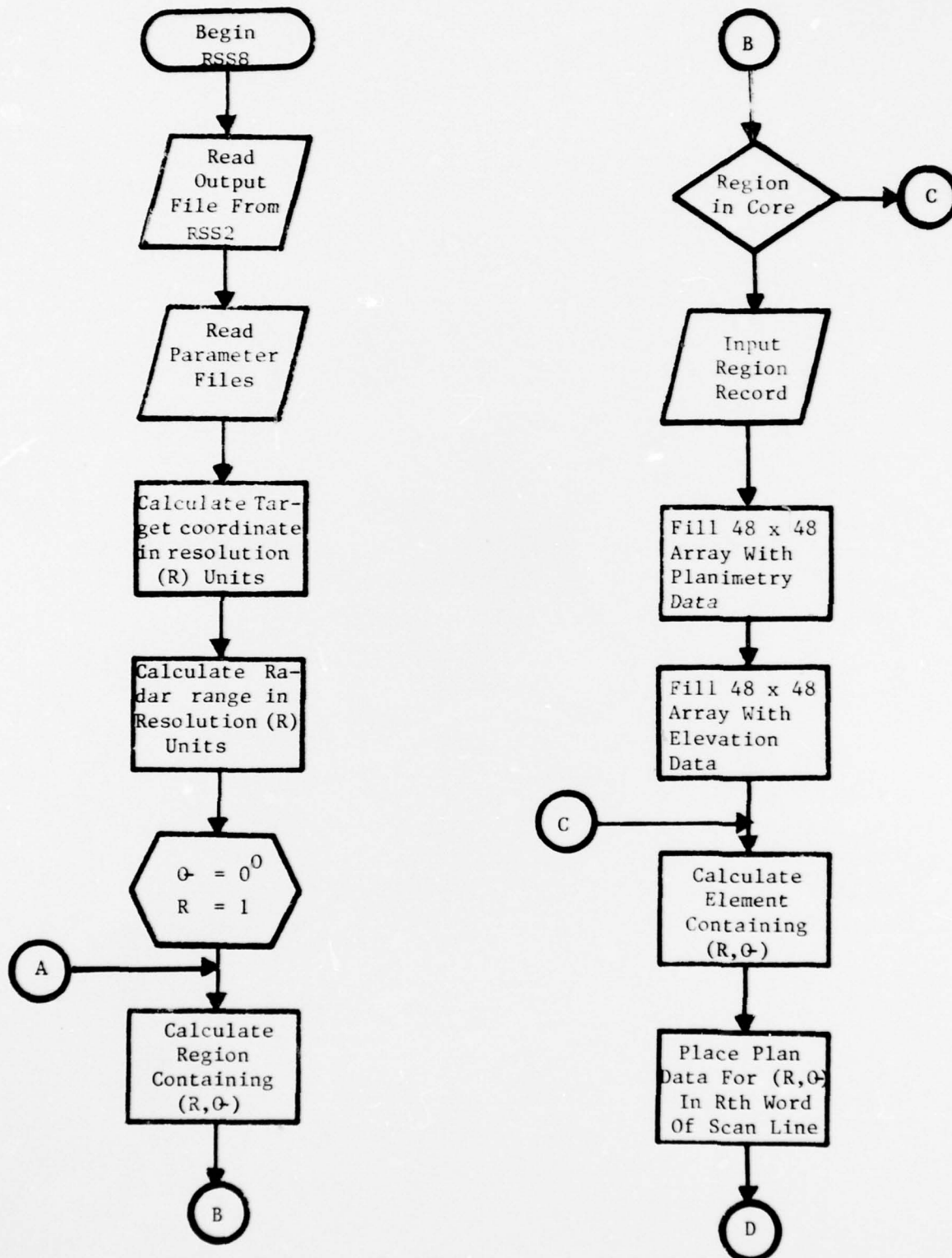

FIGURE IV.7 - PROGRAM RSS8 FLOWCHART
(Page 1 of 2)

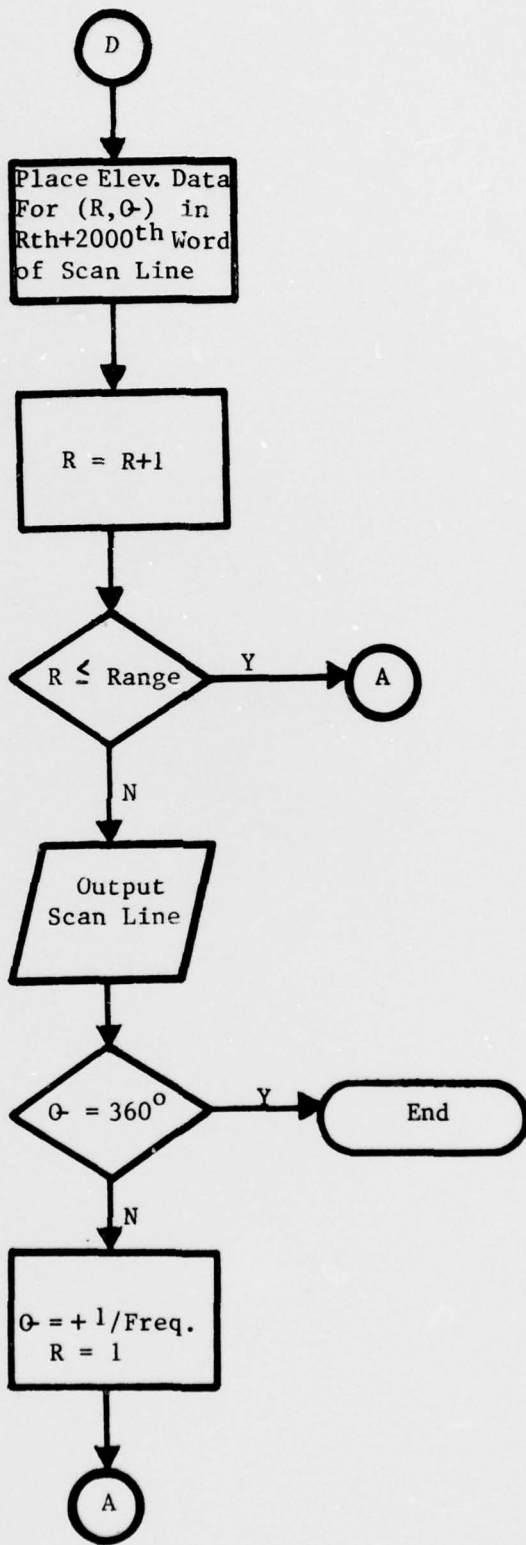

FIGURE IV.7 - PROGRAM RSS8 FLOWCHART
(Page 2 of 2)

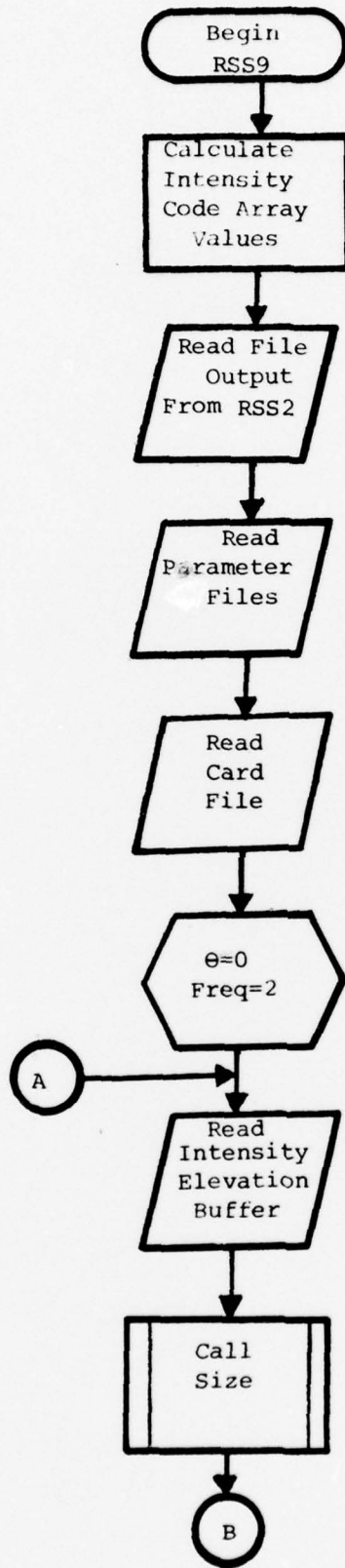

FIGURE IV.8 - PROGRAM RSS9 FLOWCHART
(Page 1 of 2)

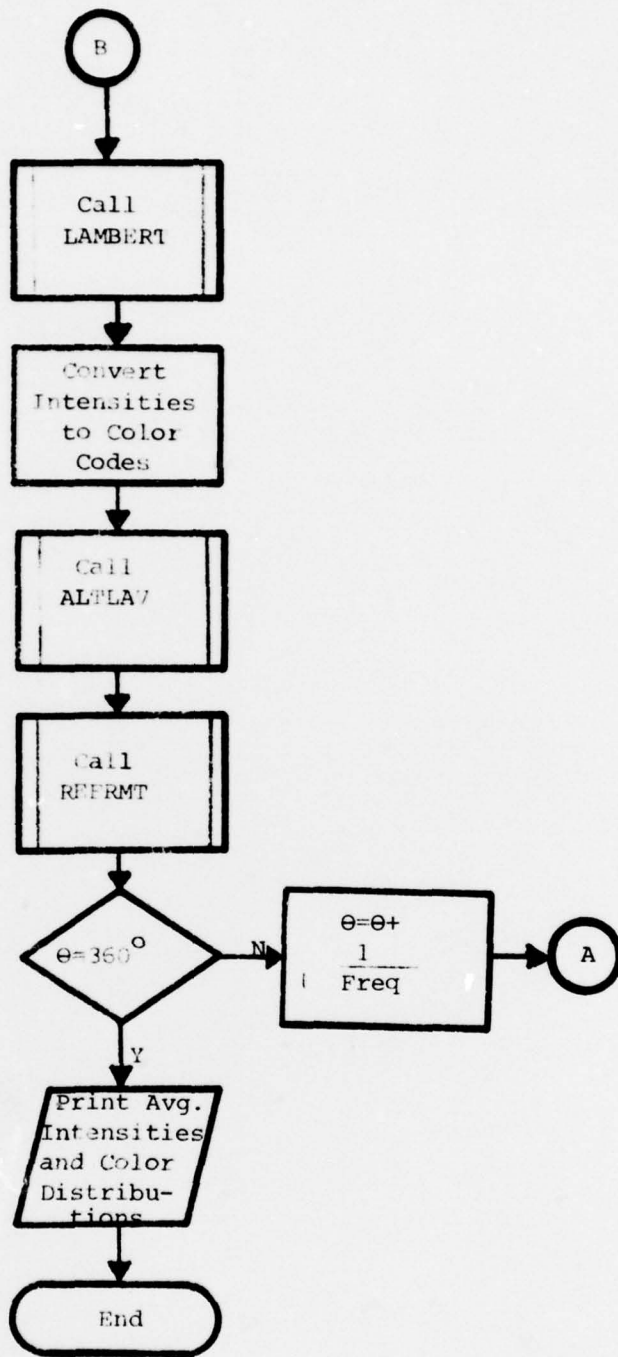

FIGURE IV.8 - PROGRAM RSS9 FLOWCHART
(Page 2 of 2)

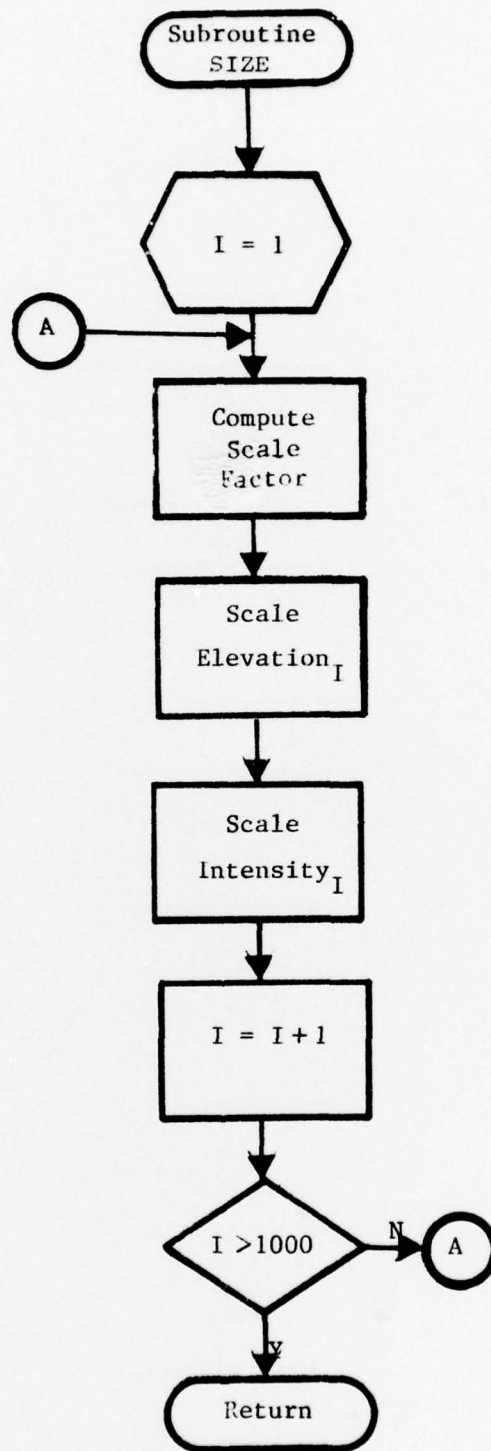

FIGURE IV.9 - SUBROUTINE SIZE FLOWCHART

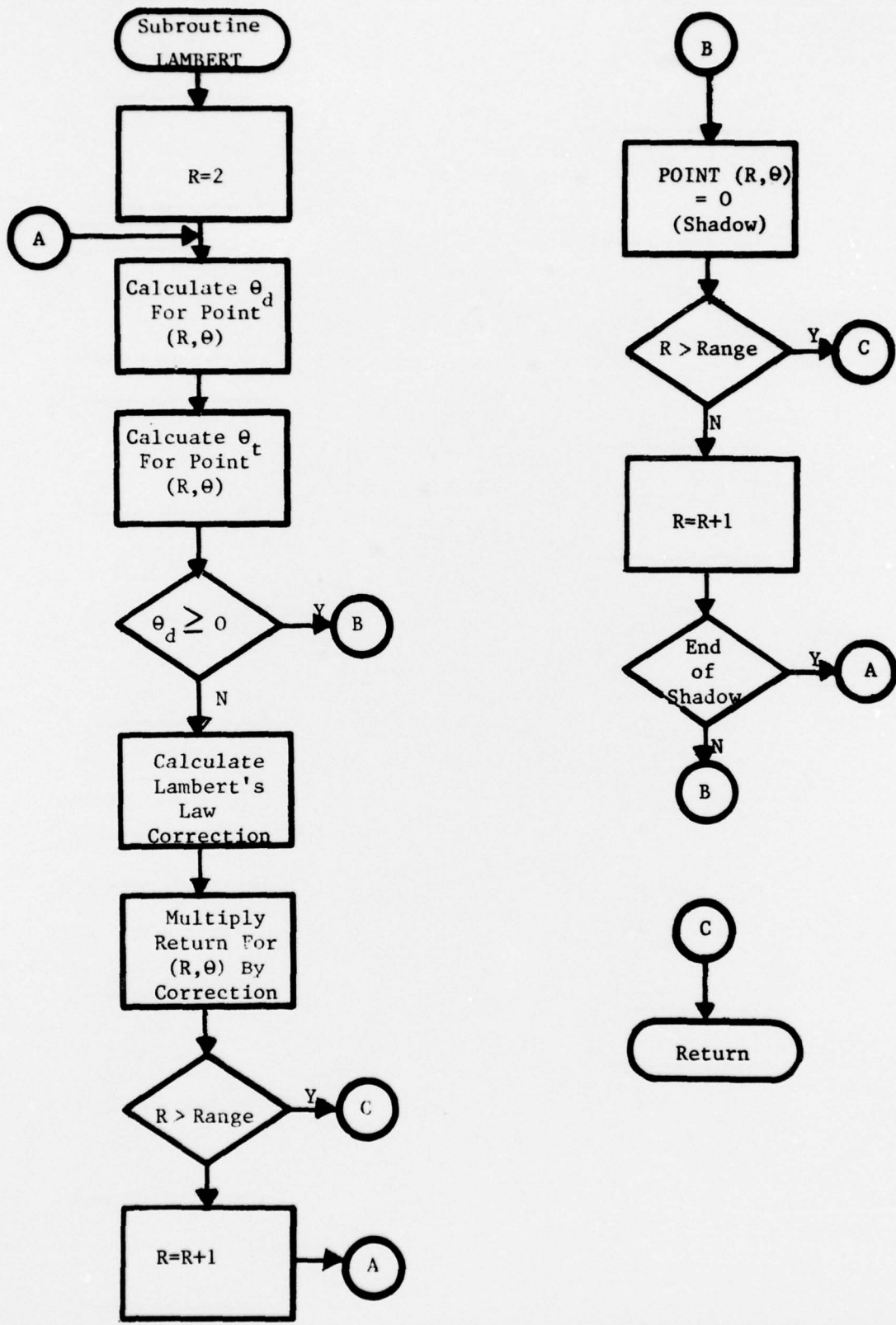

FIGURE IV.10 - SUBROUTINE LAMBERT FLOWCHART

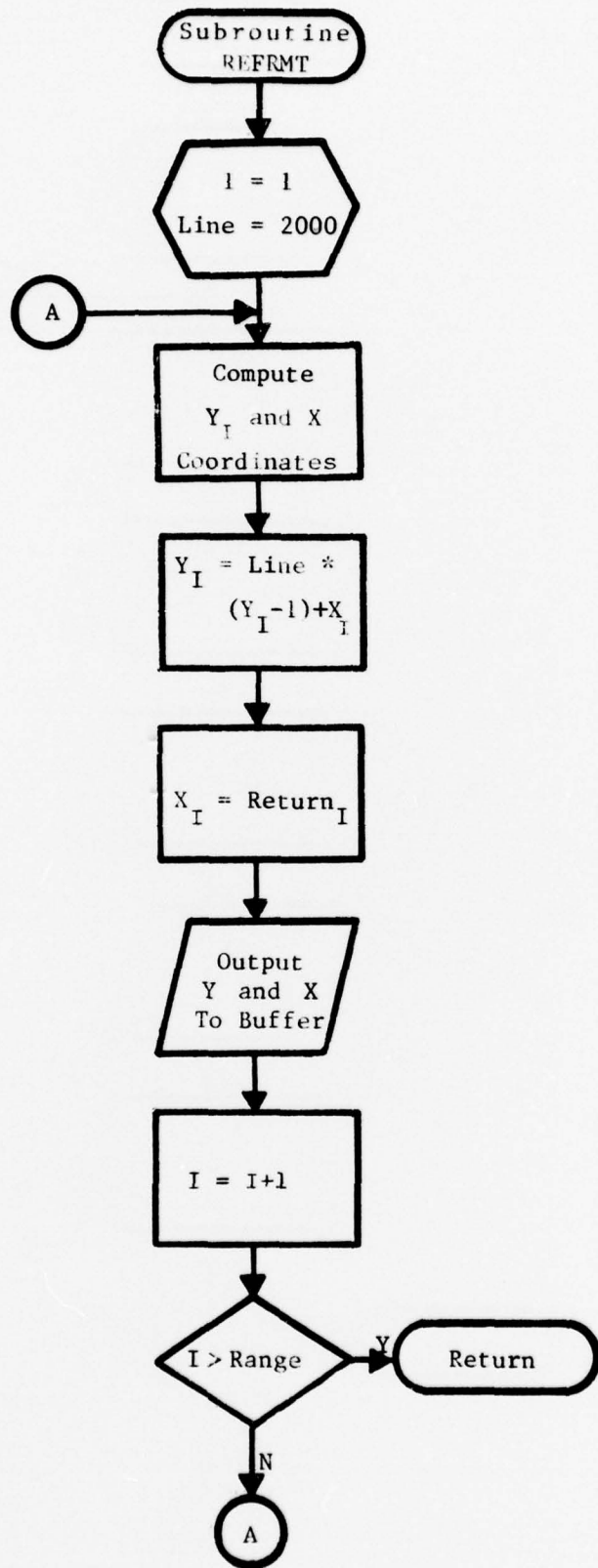

FIGURE IV.11 - SUBROUTINE REFRMT FLOWCHART

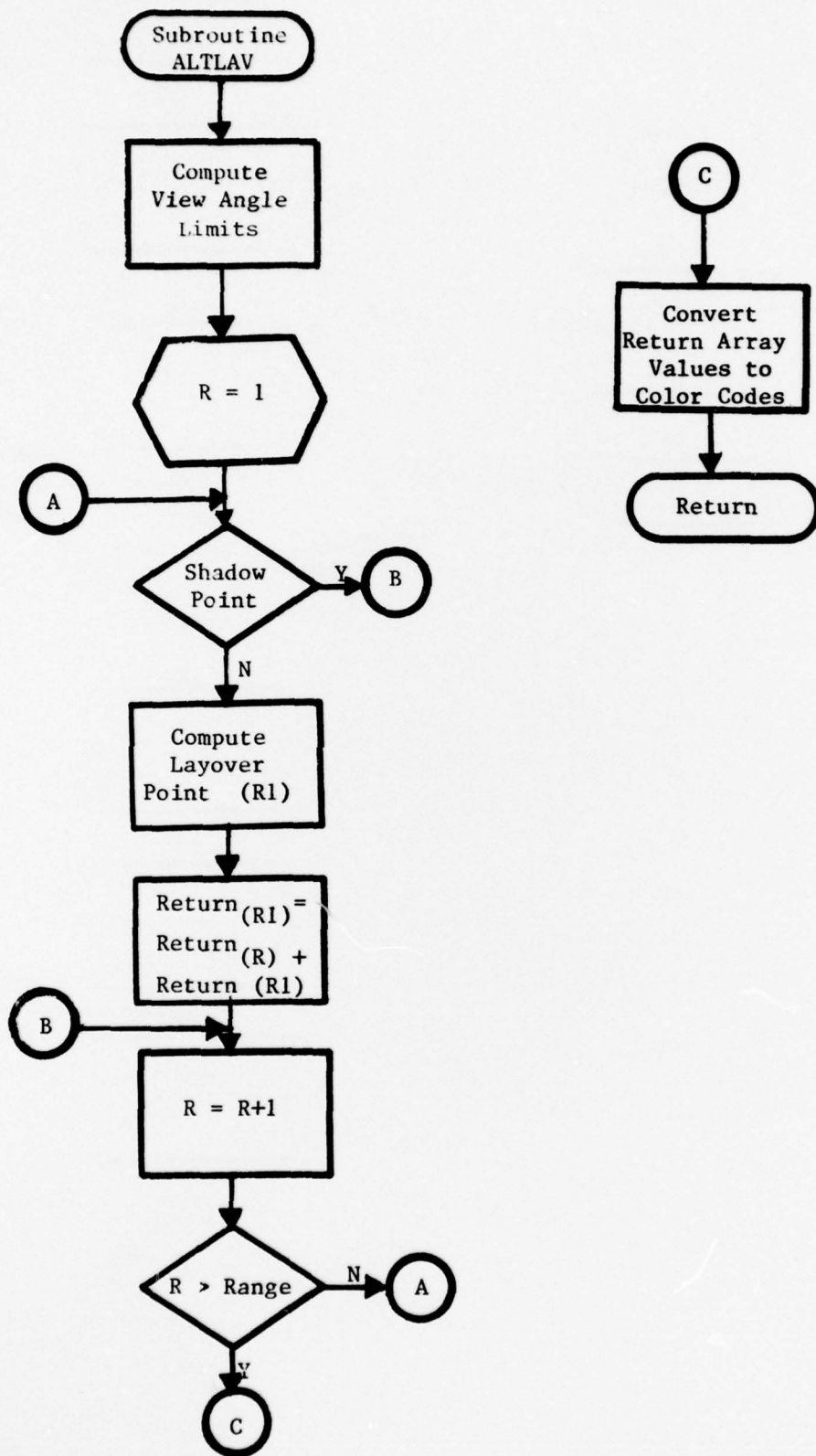

FIGURE IV. 12 - SUBROUTINE ALTLAV FLOWCHART

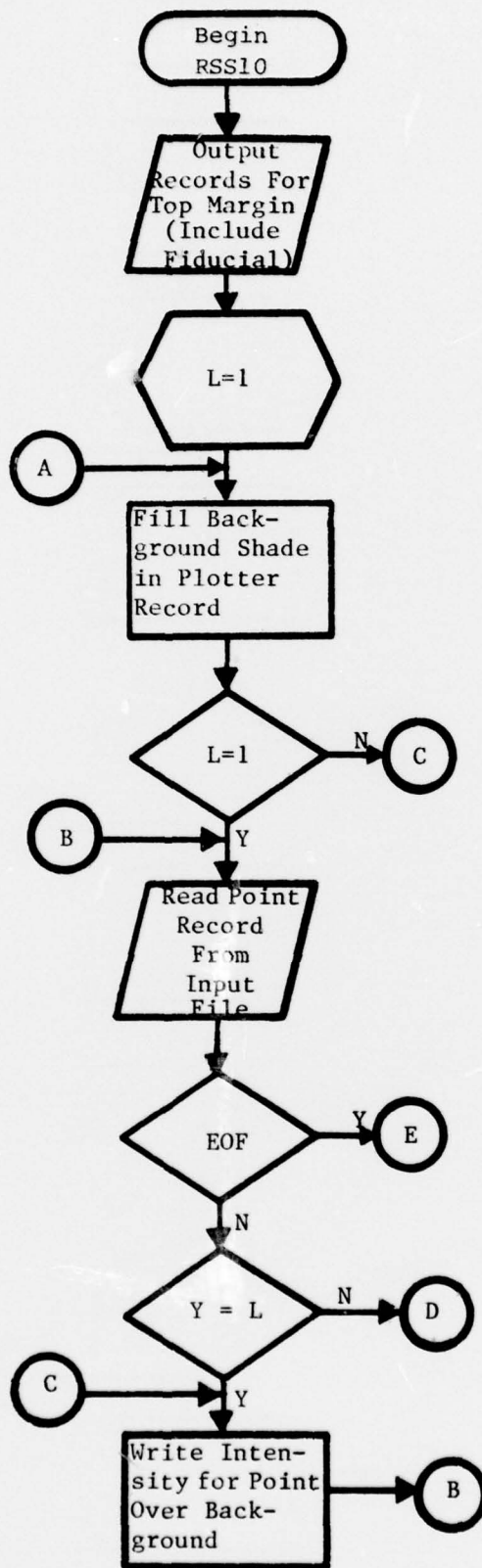

FIGURE IV.13 - PROGRAM RSS10 FLOWCHART
(Page 1 of 2)

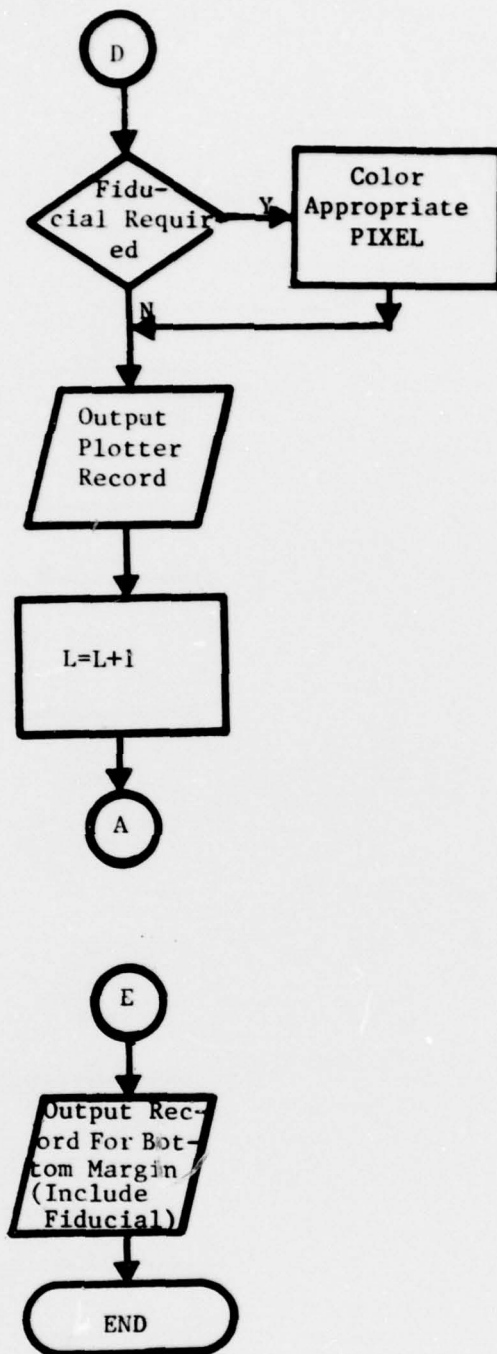

FIGURE IV.13 - PROGRAM RSS10 FLOWCHART
(Page 2 of 2)