

AD-A033 632

KINERGETICS INC TARZANA CALIF  
FINAL TECHNICAL REPORT, (U)  
APR 76 M O BENNETT, R.C LINS  
CP-2028F

F/G 15/1

DAAK02-73-C-0323  
NL

UNCLASSIFIED

1 OF 1  
AD-A  
033 632



END  
DATE  
FILMED  
2-4-77  
NTIS

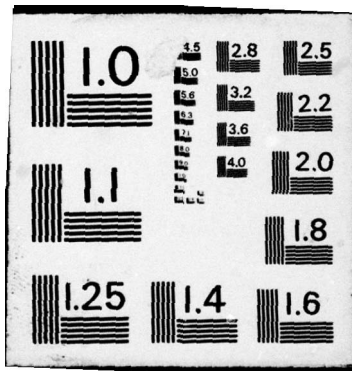

**U.S. DEPARTMENT OF COMMERCE  
National Technical Information Service**

AD-A033 632

FINAL TECHNICAL REPORT

KINERGETICS, INCORPORATED  
TARZANA, CALIFORNIA

APRIL 1976

ADA033632

365006

CP-2028

FINAL TECHNICAL REPORT  
CONTRACT DAAK02-73-C-0323

April 1976



Prepared For

U. S. Army Mobility Equipment  
Research and Development Center  
Fort Belvoir, VA 22060

D D C  
RECEIVED  
DEC 15 1976  
C

Approved for public release, distribution  
Unlimited.

REPRODUCED BY  
NATIONAL TECHNICAL  
INFORMATION SERVICE  
U. S. DEPARTMENT OF COMMERCE  
SPRINGFIELD, VA. 22161



## TABLE OF CONTENTS

<u>Section</u>		<u>Page</u>
1.0	INTRODUCTION	1-1
2.0	HEAT EXCHANGER THERMODYNAMIC DESIGN	2-1
2.1	<i>General Performance Analysis</i>	2-1
2.2	Longitudinal Conduction	2-2
2.3	Channel Flow Unbalance and Its Reduction	2-3
2.4	Design Analysis Results	2-7
3.0	HEAT EXCHANGER PHYSICAL DESIGN	3-1
3.1	<i>General Configuration</i>	3-1
3.2	<i>Detail Description</i>	3-3
4.0	FABRICATION PROCESS	4-1
4.1	<i>General Description</i>	4-1
4.2	<i>Process Refinements Initiated During Project</i>	4-2
5.0	CONCLUSIONS AND RECOMMENDATIONS	5-1
	APPENDIX A	A-1

## LIST OF ILLUSTRATIONS

<u>Figure</u>		<u>Page</u>
2-1	Conductivity of a Packed Bed	2-4
2-2	Unbalanced Flow Control Schematic	2-6
2-3	Illustration of how Flow Compensation Technique is Incorporated into Counter-Flow Exchanger	2-8
2-4	Heat Exchanger Thermodynamic State Schematic	2-10
3-1	Physical Schematic Diagram of Heat Exchanger	3-2
3-2	Layout -- Heat Exchanger System (Sheet 1 of 2)	3-4
3-3	Layout -- Heat Exchanger System (Sheet 2 of 2)	3-5
4-1	Lamina Fixture with Lamina Installed	4-5
4-2	Examples of Variation in Thickness of Woven Screen	4-7

## LIST OF TABLES

<u>Table</u>		<u>Page</u>
I	Design Analysis Results	2-9
II	Wire Screens Usable with 0.010-inch Thick Plastic	4-3

## NOTATION

$A_c$	= effective flow area ( $\epsilon A_f$ )
$A_k$	= conduction area of wire in the plastic wall
$A_f$	= heat transfer area for one side of the exchanger
$A_{fr}$	= frontal area
$B$	= defined as $L_k(4h/kd_w)^{1/2}$
$C$	= heat capacity rate ( $\dot{m} C_p$ )
$C_{min}$	= heat capacity rate ( $\dot{m} C_p$ ) for side of exchanger with smallest flow rate
$C_p$	= specific heat at constant pressure
$d_w$	= wire diameter of wire screen
$f$	= Fanning friction factor
$G$	= mass flow rate/unit area
$h$	= convection film coefficient
$j$	= Colburn modulus as obtained from $(h/C_p G) N_{Pr}^{2/3}$
$k$	= thermal conductivity
$L$	= flow length
$L_k$	= effective conduction length of wire between adjacent gas passages
$L_{kw}$	= conduction length of wire in wall
$\dot{m}$	= mass flow rate
$N_{Pr}$	= Prandtl number
$NTU$	= overall number of heat transfer units
$NTU_A$	= measured NTU ( $\Delta T/\delta T$ )
$NTU_h$	= number of heat transfer units for the high-pressure side of the heat exchanger
$NTU_i$	= number of heat transfer units for a single side in the exchanger or for conduction between adjacent sides
$NTU_l$	= number of heat transfer units for the low-pressure side of the heat exchanger
$P$	= pressure
$Q$	= heat transfer rate
$R$	= transfer function
$r_h$	= hydraulic radius

Notations (continued)

- $T$  = temperature  
 $\Delta T$  = temperature difference between flow entering and leaving on one side of the heat exchanger  
 $\delta T$  = temperature difference between entering and leaving streams at same end of the exchanger

Greek Letters

- $\epsilon$  = void volume fraction  
 $\lambda$  = dimensionless conduction parameters  
 $\eta_f$  = fin effectiveness of wire in exchanger given by  $(\tanh B)/B$   
 $\rho$  = density of fluid  
 $\mu$  = viscosity of fluid

Subscripts

- $c$  = cold stream  
 $h$  = hot stream

REFERENCES

- 1) W. M. Kays and A. L. London, Compact Heat Exchangers, 2nd ed., McGraw-Hill Book Company, New York (1964).
- 2) W. H. McAdams, Heat Transmission, 3rd ed., McGraw-Hill Book Company, New York (1954).
- 3) R. B. Fleming, in: Advances in Cryogenic Engineering, Vol. 12, Plenum Press, New York (1967), p. 352.
- 4) K. W. Cowans, in: Advances in Cryogenic Engineering, Vol. 19, Plenum Press, New York (1974), p. 437.

## 1.0 INTRODUCTION

The objective of Contract DAAK02-73-C-0323 between Kinergetics Incorporated and the U. S. Army Mobility Equipment Research and Development Center was to demonstrate the feasibility of manufacturing compact heat exchangers by bonding wire screens into low conductivity (i.e. plastic) material and to utilize the manufacturing techniques to manufacture a set of compact, high-performance, cryogenic heat exchangers suitable for integration into a Claude cycle refrigeration system.

During the course of the program, the feasibility of manufacturing compact heat exchangers was successfully demonstrated by manufacturing several leak tight heat exchanger sections; however, it was also found that the critical manufacturing process is very sensitive to certain physical parameters of the raw material used in the process. These particular physical parameters are characteristically under the control of commercial manufacturers and are generally not of sufficient importance in the general material end use to warrant the level of quality control necessary for high yield in the heat exchanger fabrication process. The particular raw materials of interest are the copper wire screen and the epoxy plastic laminate.

The solution to these materials problems is correctable by writing a materials specification to specify the acceptable range of values for the various materials parameters found in the course of this program to be particularly critical. To purchase the raw material to such specification is expected to result in both long lead-time and high cost compared to those lead times and costs experienced in purchasing the normally available materials.

In the course of the program, the heat exchanger assembly was designed and documented. The design incorporates many features which reflect the experiences in correcting problems found in prior heat exchanger assemblies. The primary design feature is the incorporation of the intersection manifolding into the exchanger itself. This is done to preclude the leakage problems which were experienced in designs with the manifolds coupled externally to the exchanger assembly.

The new manifolding technique was applied to a heat exchanger of similar design to the unit described in this report. During the testing of this assembly, the heat exchanger performance data indicated that leaks had developed at the manifolds. The problem which developed is attributable to a new type of adhesive which was used to join the aluminum manifold to the epoxy heat exchanger sections. The adhesive which had been proven successful in the past for cryogenic applications had, at that time, been removed from the market as a result of its being a suspected carcinogen.

## 2.0 HEAT EXCHANGER THERMODYNAMIC DESIGN

### 2.1 General Performance Analysis

The performance of the exchanger is analyzed using the basic NTU and pressure drop relations. Given a desired effectiveness, the required NTU is  $e/(1 - e)$ . The basic overall design NTU (without longitudinal conduction) is obtained from

$$\frac{1}{\text{NTU}} = \frac{1}{\text{NTU}_h \eta_{f_h}} + \frac{1}{kA_k/L_{k_w} C} + \frac{1}{\text{NTU}_l \eta_{f_c}}$$

and the individual package NTU's are equal to

$$\frac{1}{N_{Pr}^{2/3}} = \frac{1}{r_h}$$

The Colburn modulus

$$j = (h/C_p G) N_{Pr}^{2/3}$$

is found from Reference 1.

The hydraulic radius of wire mesh is given by

$$r_h = \frac{d_w}{4} \times \frac{\epsilon}{1 - \epsilon}$$

Special care must be taken in the evaluation of the conduction parameters. Because the wires are not all oriented perpendicular to the walls, the effective conduction length varies randomly. On the average, the wires will be at a  $45^\circ$  angle, and the conduction lengths  $L_k$  can be considered as

$$L'/\cos 45^\circ = 1.414 L'$$

where  $L'$  is the thickness of the wall or one-half of the gas passage width, depending on the computation. Also, the effective conduction area through the wall consists almost totally of the wire cross section only (because of the low conductivity of the plastic); this area is equal to the product of the wall side area and the quantity  $(1 - \epsilon)$ .

The pressure drop is given by the Fanning equation as

$$\Delta P = \frac{f}{2} \frac{G^2}{\rho} \frac{L}{r_h}$$

where  $f$  is again taken from Reference 1.

The effects of longitudinal conduction for the complete exchanger (including gas passages) are then calculated as described in the next section. Finally, a safety factor of about 10% (this varies with the required effectiveness) is added to compensate for any remaining flow unbalance.

The procedure for arriving at an acceptable design is obviously iterative. It can be shortened significantly by using the design equation

$$\frac{\Delta P}{NTU_j} = \frac{1}{2} \frac{f}{j} \frac{G^2}{\rho} N_{Pr}^{2/3}$$

to arrive at a starting point for required flow area. This equation is applied to both gas flows separately and the  $NTU_j$  used must be at least double the required overall value, with factors added for the various conduction parameters. A value of 2.5  $NTU_j$  is normal. The ratio  $f/j$  can be assumed to be constant with a value of ten for the Reynolds numbers of interest.

## 2.2 Longitudinal Conduction

The method for analyzing longitudinal conduction effects <sup>(1)</sup> uses the factor

$$\lambda = \frac{(k/L)A_k}{C_{\min}} = \frac{\Delta e}{e}$$

with the following  $k$  values in  $\text{Btu}/(\text{hr}\cdot\text{ft}^2 \cdot ^\circ\text{F}/\text{ft})$ :

$$k_{\text{copper}} = 226, \quad k_{\text{plastic}} = 0.075, \quad k_{\text{plastic-copper bed}} = 0.255$$

The value for the conductivity of the plastic-copper ( $k_{\text{plastic-copper bed}}$ ) was obtained from data presented by McAdams<sup>(2)</sup>. The data, in graphical form (Fig. 2-1), give the thermal conductivity of a packed bed of spherical particles containing stagnant interstitial fluid for various void volume fractions. (The data have been extrapolated to include standard wire mesh screen void volumes.) The bed conductivity  $k_B$  is correlated by plotting  $k_B/k_g$ , the ratio of bed conductivity to stagnant fluid conductivity vs.  $k_s/k_g$ , the ratio of matrix material conductivity to stagnant fluid conductivity. This result is applied to the subject case by considering the plastic to be the low-conductivity interstitial fluid, i.e.,  $k_g = k_{\text{plastic}}$ .

### 2.3 Channel Flow Unbalance and Its Reduction

The deleterious effects of unbalanced channel flow on high-efficiency counterflow heat exchangers has long been known, and was analyzed in a paper by Fleming<sup>(3)</sup>. This analysis computed the degradation in exchanger NTU as a function of the magnitude and extent of the unbalance. The results showed that, for a 99% design effectiveness exchanger, if the flow in 20% of the channels varies by  $\pm 10\%$  from nominal, the actual exchanger effectiveness is reduced to about 98%. This is equivalent to a 50% reduction in NTU. This magnitude of flow variation is not at all uncommon, despite close attention to tolerances and headering. For example, in a tubular channel with laminar flow, the mass flow is proportional to the fourth power of the hydraulic diameter, and a  $\pm 3\%$  size variation will produce a 13% change in flow.

This exchanger utilizes a patented technique which has the effect of forcing the individual channel flows into a more or less balanced state, regardless of passage size variations and nonuniform manifolding. This technique was described in detail

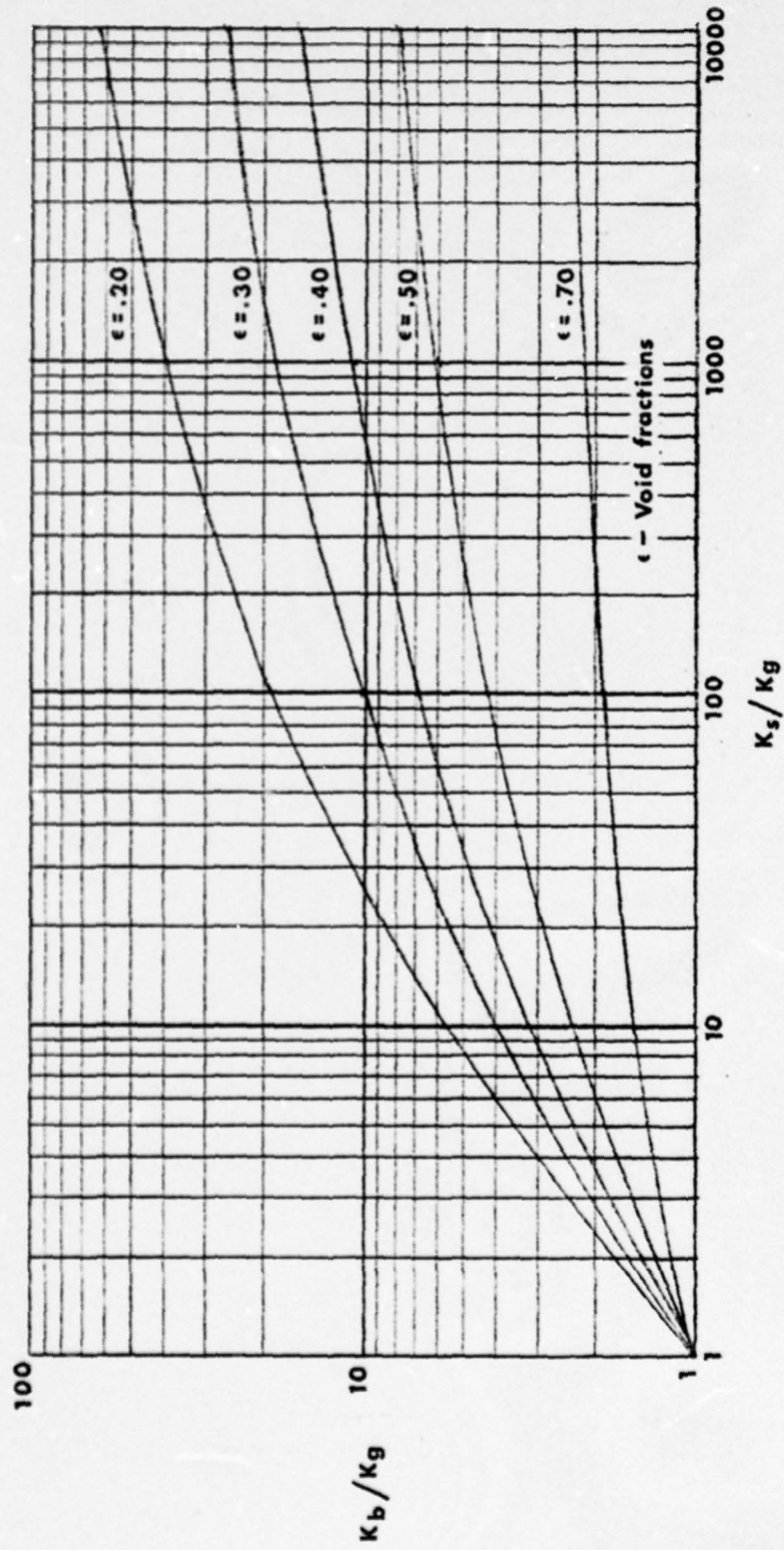

Figure 2-1 - Conductivity of a Packed Bed (Ref. 2)

by Cowans<sup>(4)</sup> and will be treated in only a general manner here. Basically, it can be considered as a quasi-negative feedback control system, as shown in the block diagram of Fig. 2-2. In any flow channel, the pressure difference between inlet and outlet causes a mass flow in proportion to the pressure drop and is governed by geometrical and fluid property factors. For laminar flow (the normal condition), this can be written as

$$\dot{m} = \left( \frac{2r_h^2 A_f}{L} \right) \left( \frac{\rho}{\mu} \right) \Delta P = R_l \Delta P$$

In a counterflow exchanger, if the mass flow of an individual channel changes with respect to the flow in adjacent channels, the temperature gradient in this channel also changes due to energy conservation effects. The mass flow is dependent on the physical properties of density and viscosity as well as channel geometry (as noted in the above equation) and these are in turn proportional to  $1/T$  and  $T^{0.7}$ , respectively. Therefore we have

$$\dot{m} \sim \Delta P / T^{1.7}$$

and an increase in temperature tends to decrease the mass flow. This effect, however, does not provide for stabilization in a normal exchanger, because a temperature rise in the high flow channel creates an even greater rise in temperature in the adjacent channels, restricting their flow also.

This temperature-pressure drop relation can be used to stabilize the flows by making the effect of the temperature change (due to mass flow change) greater in the hot flow passages than in the cold ones. This is accomplished by taking advantage of the fact that the greatest deviation from the design temperature gradient, due to unequal flows, occurs at the longitudinal center of the flow passage. If a small restriction is placed at the midpoint of the hot flow passages, such that it is the dominant factor in governing the mass flow, then initial changes in mass flow will create a proportionately large change in restriction. However,

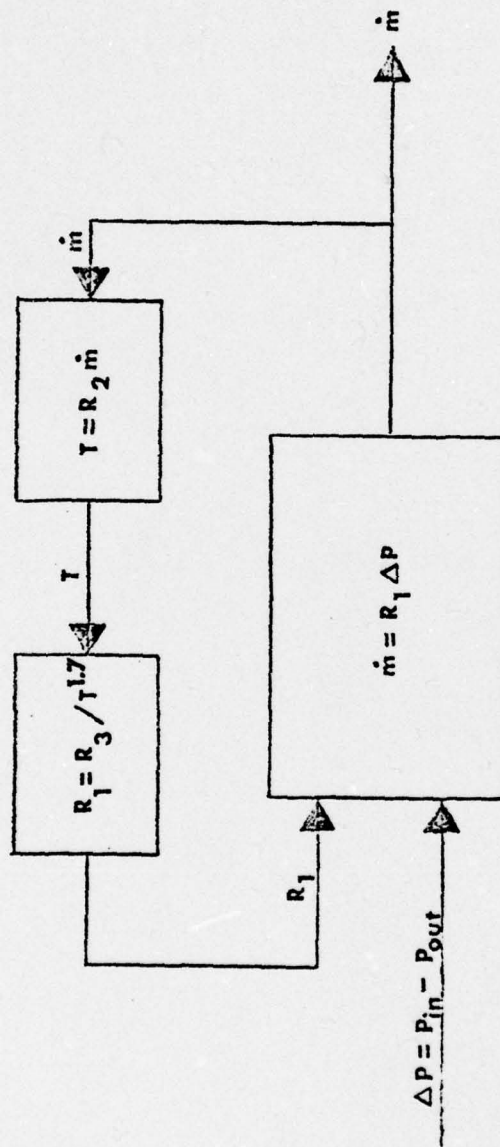

Figure 2-2 - Unbalanced Flow Control Schematic

the adjacent cold flows will not experience the same proportionate change in restriction even though their fluid temperature does rise from the increased heat transfer. Therefore, the net effect is to bring the hot mass flow rate back to nearly the level of the cold flows. The converse is, of course, true if the hot flow is less than the adjacent cold flows.

Incorporation of this compensation feature was the necessary step in obtaining true 99+% effectiveness in a compact exchanger. It was first proven in a corrugated "100% primary surface" exchanger with a design NTU of 200. The best efforts at maintaining close passage tolerances and perfect manifolding had produced a maximum actual NTU of only 33. After incorporating the flow compensation geometry, the actual NTU improved to 167, or a fivefold gain. This technique can, of course, be applied to any form of counterflow exchanger. It is particularly adaptable to the screen-plastic type, since only a change in the flow passage cutout for the middle section lamina is required. This is illustrated for the subject exchanger in Fig. 2-3.

#### 2.4 Design Analysis Results

The results of the design analysis performed per the procedure outlined in the preceding sections are presented in Table I. The specification requirements are also shown for comparison, and the specified system flow diagram is presented in Fig. 2-4. Note that the design NTU values are sufficient for an exchanger of 99% effectiveness while only 98.5% is required. However, the pressure drops of the first three sections (particularly in the low pressure side) are excessive. This is a result of limitations on usable screen mesh and section sizes with the current fabrication techniques.

The longitudinal conduction effects have not been included in the above, as they are relatively insignificant. The most critical section is the coldest. In this section,  $C = 54 \text{ watts/}^\circ\text{K}$ ,  $k = 22.5 \times 10^{-3} \text{ watts/cm}^\circ\text{K}$ ,  $A = 21.75 \text{ cm}^2$ , and  $l = 13.3 \text{ cm}$ . Then

$$\frac{\Delta e}{e} = .675 \times 10^{-3}$$

and the loss in effectiveness is .067% of the total  $e$  of .99.

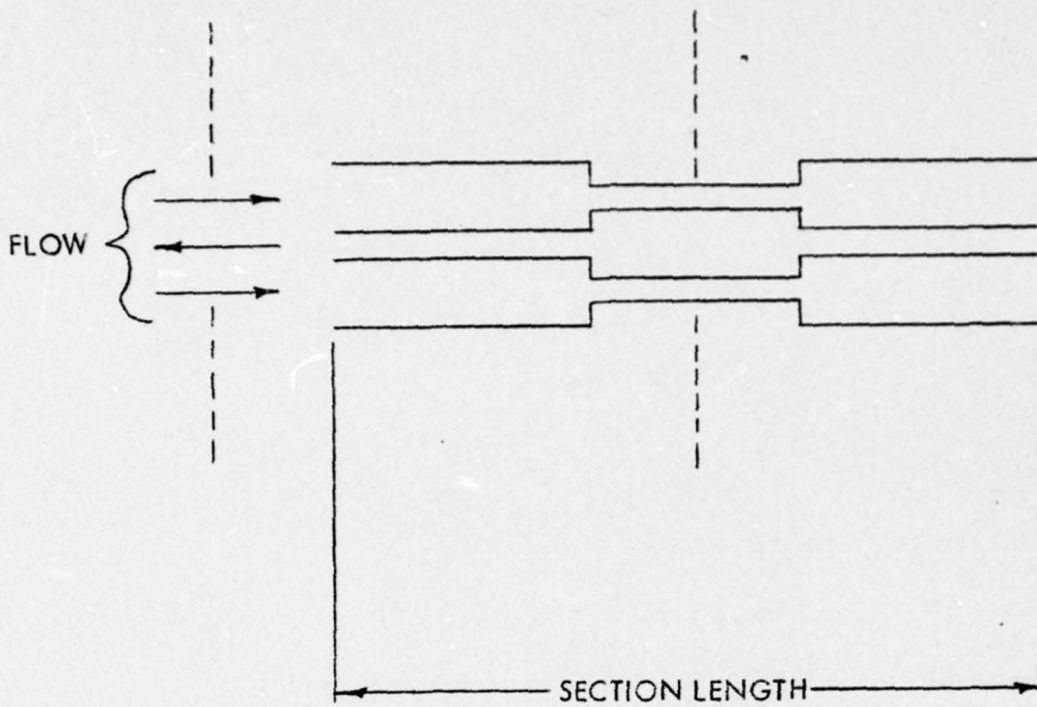

Figure 2-3 - Illustration of How Flow Compensation Technique is Incorporated Into Counter-Flow Exchanger

TABLE I

Design Analysis Results

.0075 Diameter 60 Mesh

Section	Length (In.)	Specifications					
		$\lambda T$	$\Delta P_h$ (ATM)	$\Delta P_c$ (ATM)	$\lambda T$	$\Delta P_h$ (ATM)	$\Delta P_c$ (ATM)
1	5.73	93.5	.077	.128	65.7	.04	.01
2	1.00	12.7	.0078	.00208	7.44	.05	.01
3	7.16	100.0	.065	.102	65.7	.04	.01
4	1.00	15.42	.000313	.00171	4.37	.05	.01
5	5.24	99.6	.00715	.0103	65.7	.04	.01
TOTAL	20.13		.1573	.2441		.22	.05

Estimated Input Power = 70.8 KW  
 $\dot{m}_{Total} = 27.9 \text{ g/sec.}$   
 Pressure Ratio = 4.44

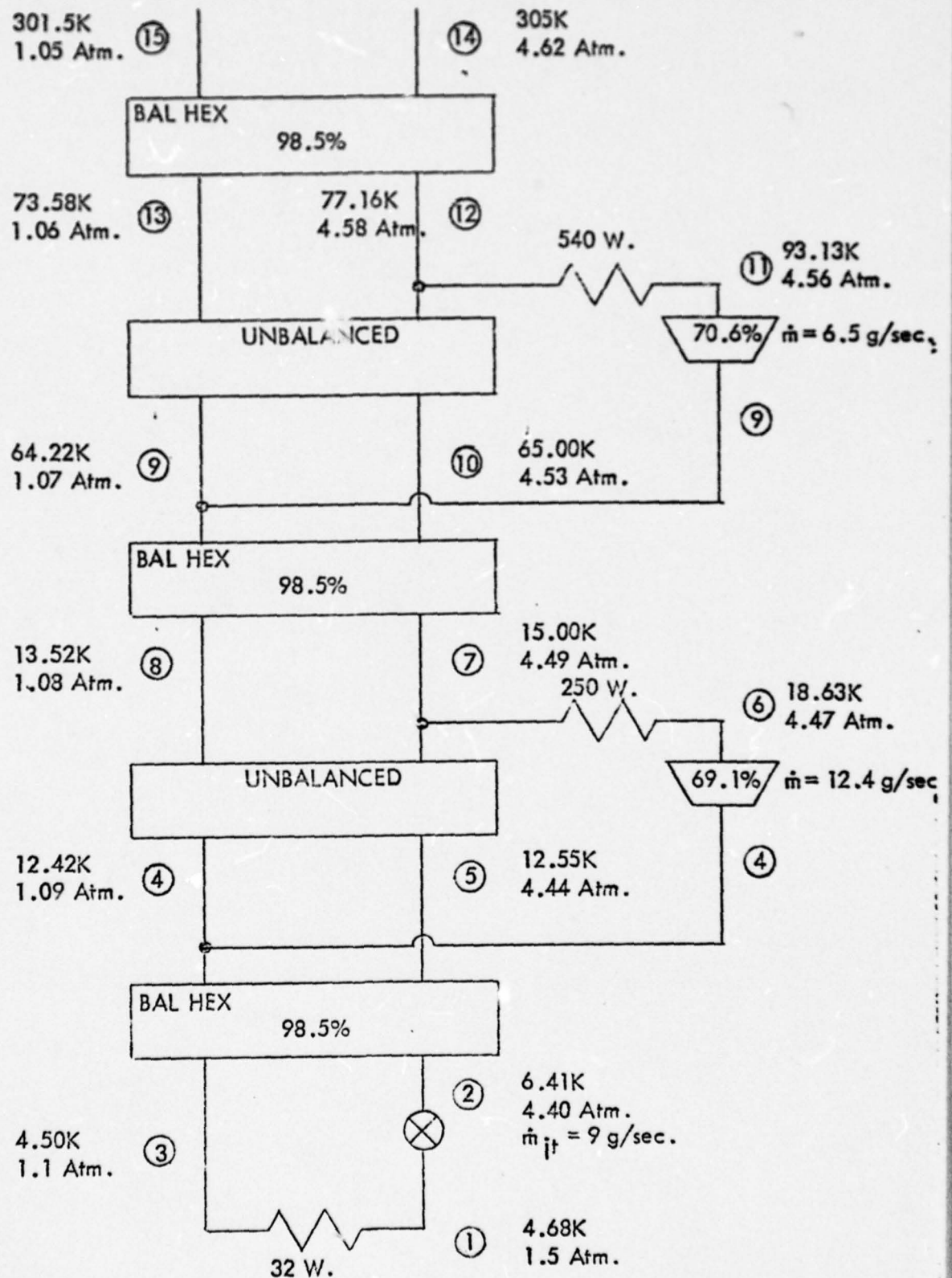

Figure 2-4 - Heat Exchanger Thermodynamic State Schematic

## 3.0 HEAT EXCHANGER PHYSICAL DESIGN

### 3.1 General Configuration

The heat exchanger consists of a set of three balanced-flow sections and two unbalanced-flow sections. This heat exchanger is designed for use in a Claude cycle refrigeration system. Due to limitations in the tooling, the cross-sectional diameter and flow passage dimensions of the modules are fixed. To allow the high design flow rate of almost 30 g/sec within allowable pressure drops, the first balanced flow section is designed to consist of two exchanger sections connected in parallel. The remaining sections of the exchanger are manifolded to the parallel sections and connected in series. The fact that the first balanced flow section contains two sections connected in parallel makes the overall physical design of this heat exchanger somewhat complex and requires definite refinements in manifold design. Figure 3-1 shows a schematic of this system.

To eliminate the manifold leakage problems which plagued prior exchanger systems, a new manifold configuration was designed. In contrast to the manifold design for the prior systems, the manifolds in the new system are an integral part of the heat exchanger rather than an exterior addition. Each manifold is part of the system structurally as well as functionally. All are designed in such a manner that the thermal contraction differences between the aluminum manifolds (which are sandwiched between the separate heat exchanger modules) and the plastic will not cause breakage at the joints.

This heat exchanger is designed to be encapsulated in a very close-fitting outer shell for the purpose of maintaining a vacuum-tight system. This shell is configured from 321 stainless steel sheet to provide both minimum weight and longitudinal conduction losses. The shell is attached only to the top manifold on the warm end of the heat exchanger. Holes are cut in the can to provide for the supply and return port flanges, which emerge from the manifold and connect to the cryogenic system turbines and other auxiliaries. Special lateral movement bellows have been designed not only to provide for longitudinal movement of the heat exchanger body with respect to the outer shell, but also to retain any leaking helium within the shell. (The longitudinal movement can be greater than 0.30 in. at the cold end of the exchanger.) Each port flange has a bellows with one end welded

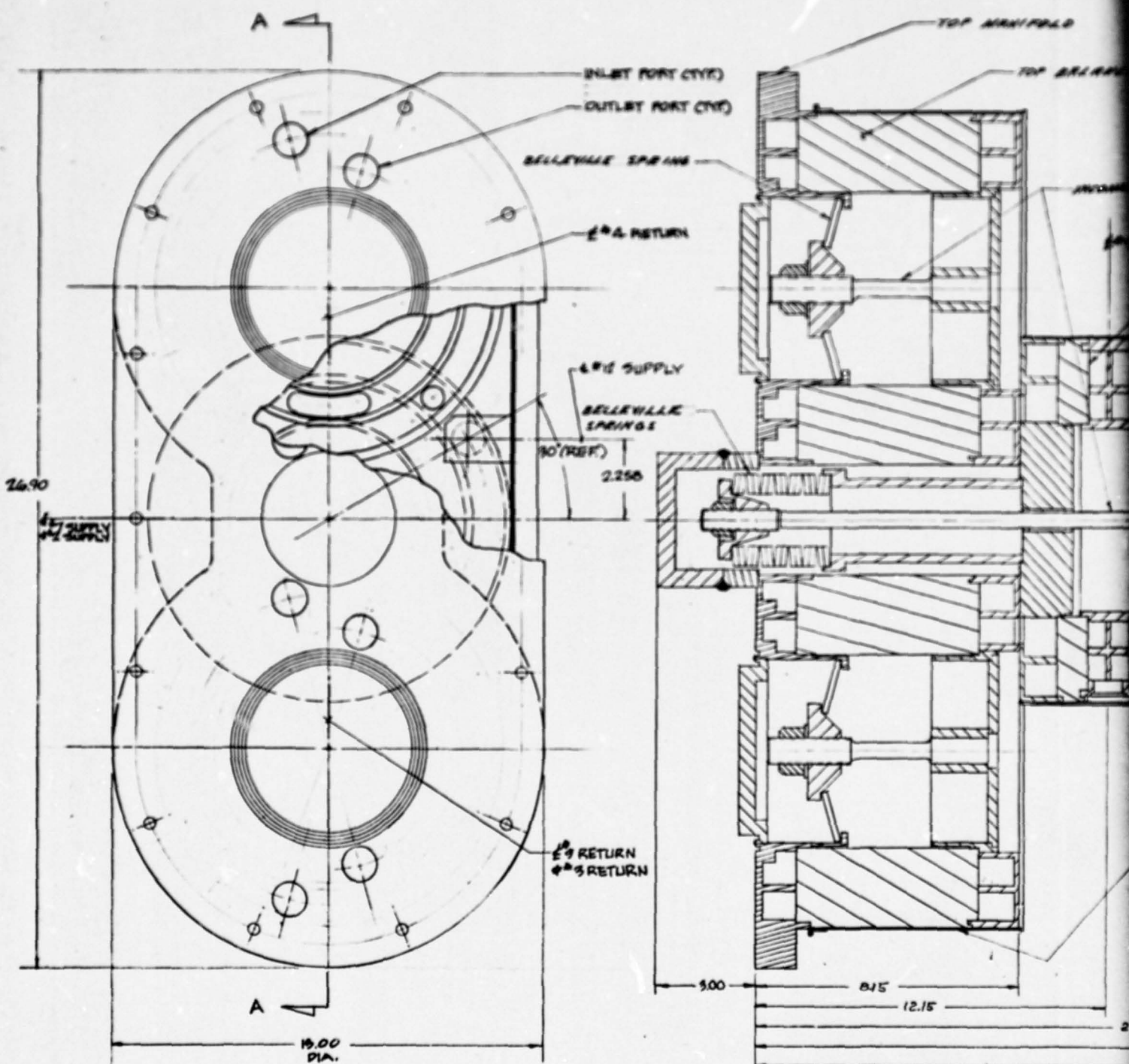

ESTIMATED WEIGHT: 390 LBS.

SECTION

STA 0.000

Preceding page blank

REVISIONS				
REV	EDD	DESCRIPTION	DATE	APPROVED
A		EDGED COVER PLATES ON TOP MANIFOLD AND CHANGED LENGTH OF OUTER SHELL	21 JUN 73	M.E. A.A.F.
B		EDGED PORT CENTERLINE LOCATIONS AND OVERALL LENGTH	21 JUN 73	M.E. A.A.F.
C		REVISED LENGTHS FOR GOYS DIA .55-.60 W/SH SCREEN PARTS	21 JUN 73	M.E. A.A.F.

BALANCED FLOW SECTION

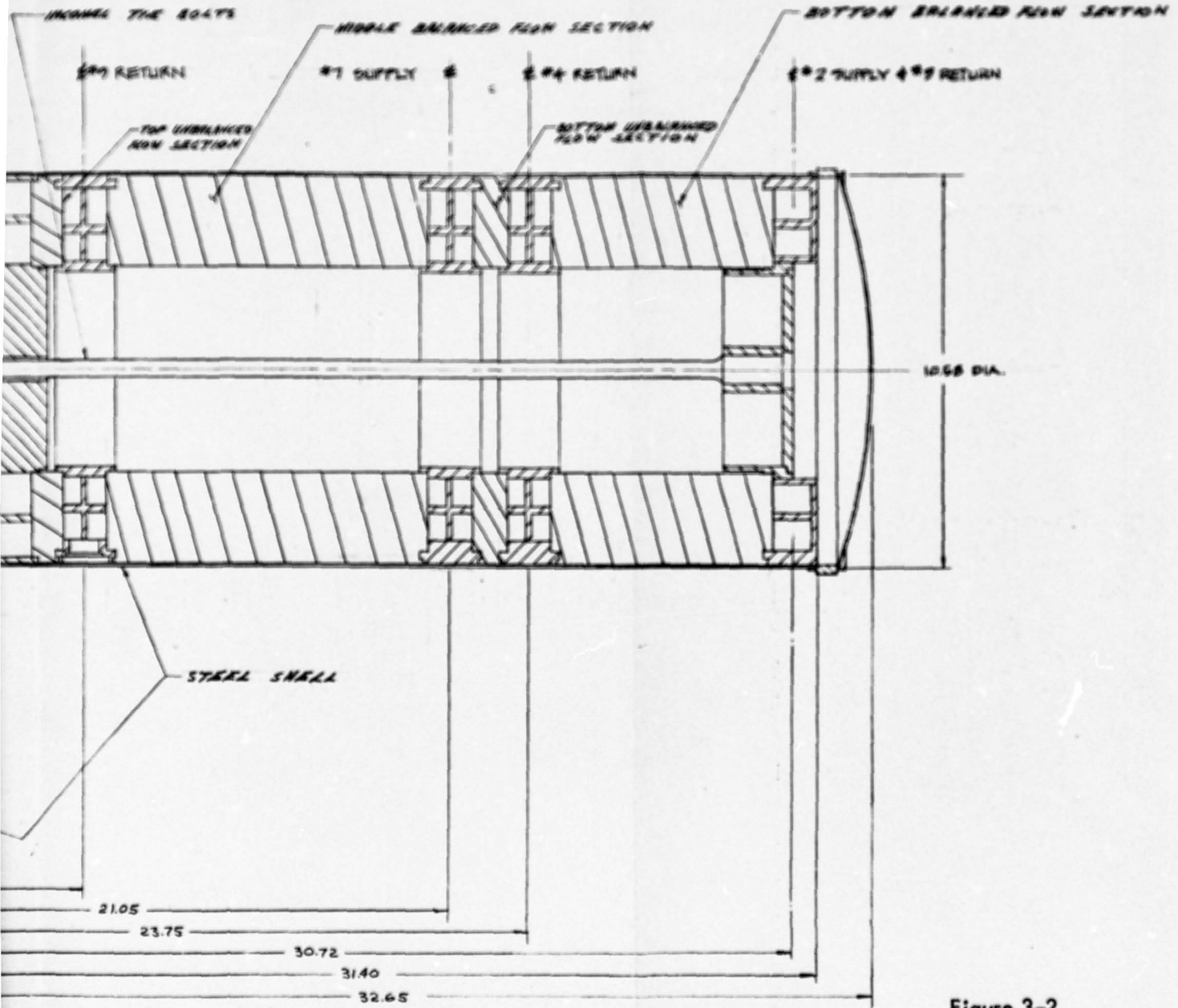

Figure 3-2

SECTION A-A

QTY REQD	QTY REQD	ITEM NO.	IDENTIFYING NO.	DESCRIPTION	MATERIAL	SPECIFICATION
LIST OF MATERIAL						
UNLESS OTHERWISE SPECIFIED			CONTR NO. CP-202B		KINETICS INC. TARZANA, CALIFORNIA 91336	
DRILL TOLERANCES			DRAWN M. ELKAN 21 JUN 73		LAYOUT - HEAT EXCHANGER SYSTEM	
.040 TO .128 + .002 - .001			CHECK G. TAYLOR 21 JUN 73			
.136 TO .228 + .003 - .001			ELEC.			
.234 TO 1/2 + .004 - .001			MECH.			
33/64 TO 3/4 + .005 - .001			DESIGN		SIZE CODE IDENT NO. D 51210 L3900	
MACH. FINISH ✓ OR BETTER			APPR.			
BREAK SHARP EDGES #10 REMOVE ALL BURRS DIMS APPLY AFTER FINISH DIMENSIONS ARE PER USAS Y143 IDENTIFY PER MIL-STD-130			APPROVED <i>[Signature]</i> 26 Jun 73			
DO NOT SCALE DRAWING			APPROVED		SCALE 1/8 WEIGHT SHEET 1 OF 2	

PART NO.	NO. REQD PER UNIT	NEXT ASSY	USED ON
			RFX-1B
APPLICATION			
FINISH			
SPEC.			
DIMENSIONS ARE IN INCHES TOL. .XX ± .03 .XXX ± .010 FRACT ± 1/32 ANG ± 0° 30'			

L3900 | C

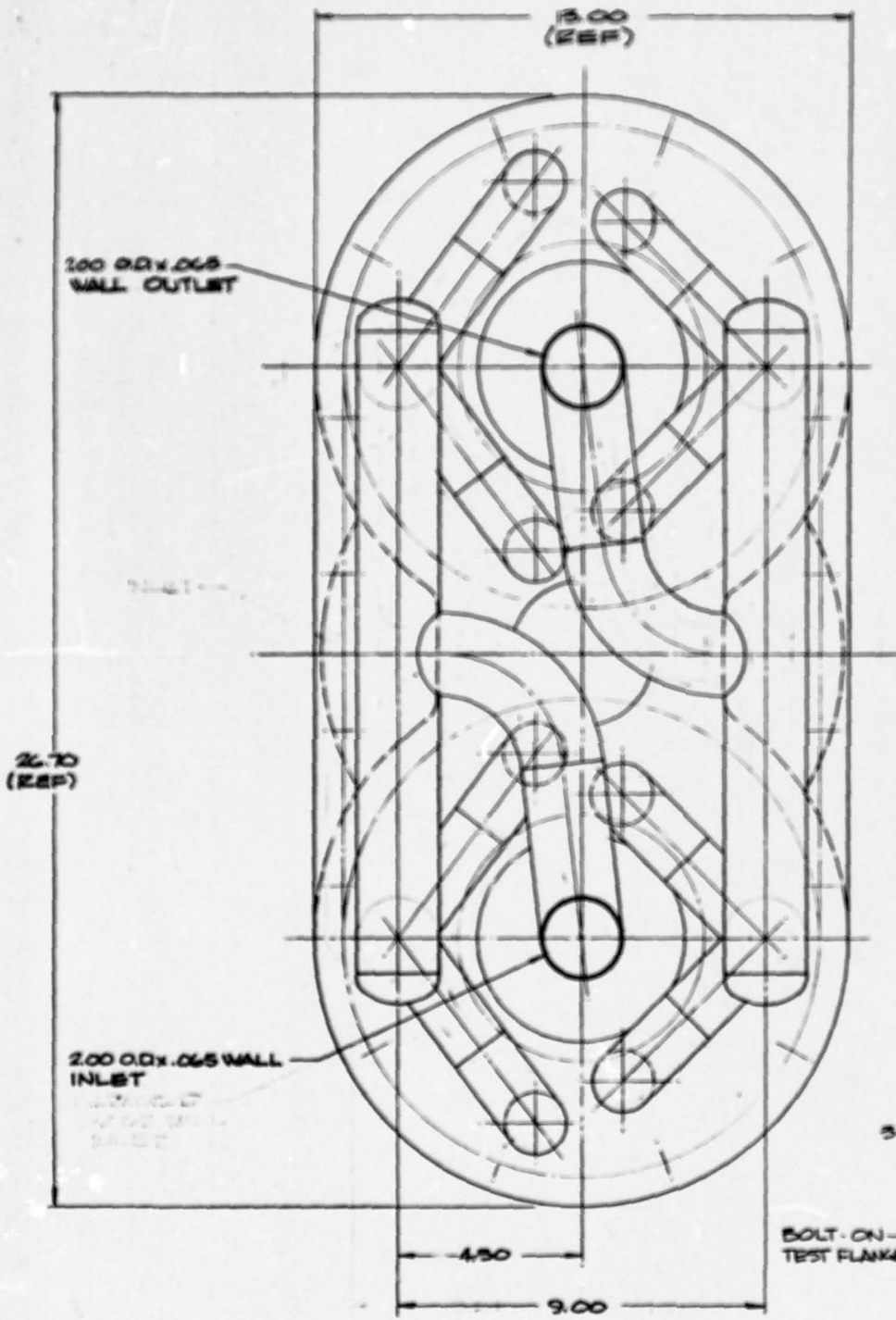

ESTIMATED WEIGHT: 390 LBS

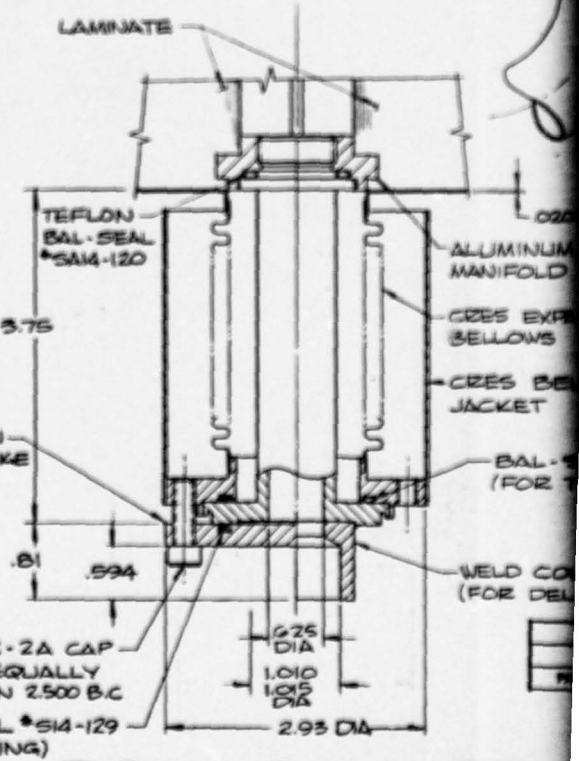

6-1/4-20 NC-2A CAP  
SCREWS EQUALLY  
SPACED ON 2.500 B.C  
BAL-SEAL #S114-129  
(FOR TESTING)

TYPICAL FLANGE DETAIL  
SCALE: 1/1

REVISIONS				
LTN	EDD	DESCRIPTION	DATE	APPROVED
A		REVISED INLET AND OUTLET MANIFOLD	11-21-73 G.T.	A.A.F.
B		REVISED TYPICAL FLANGE DETAIL	12-10-73 G.T.	A.A.F.
C		REVISED #12 DIM	12-10-73 G.T.	A.A.F.

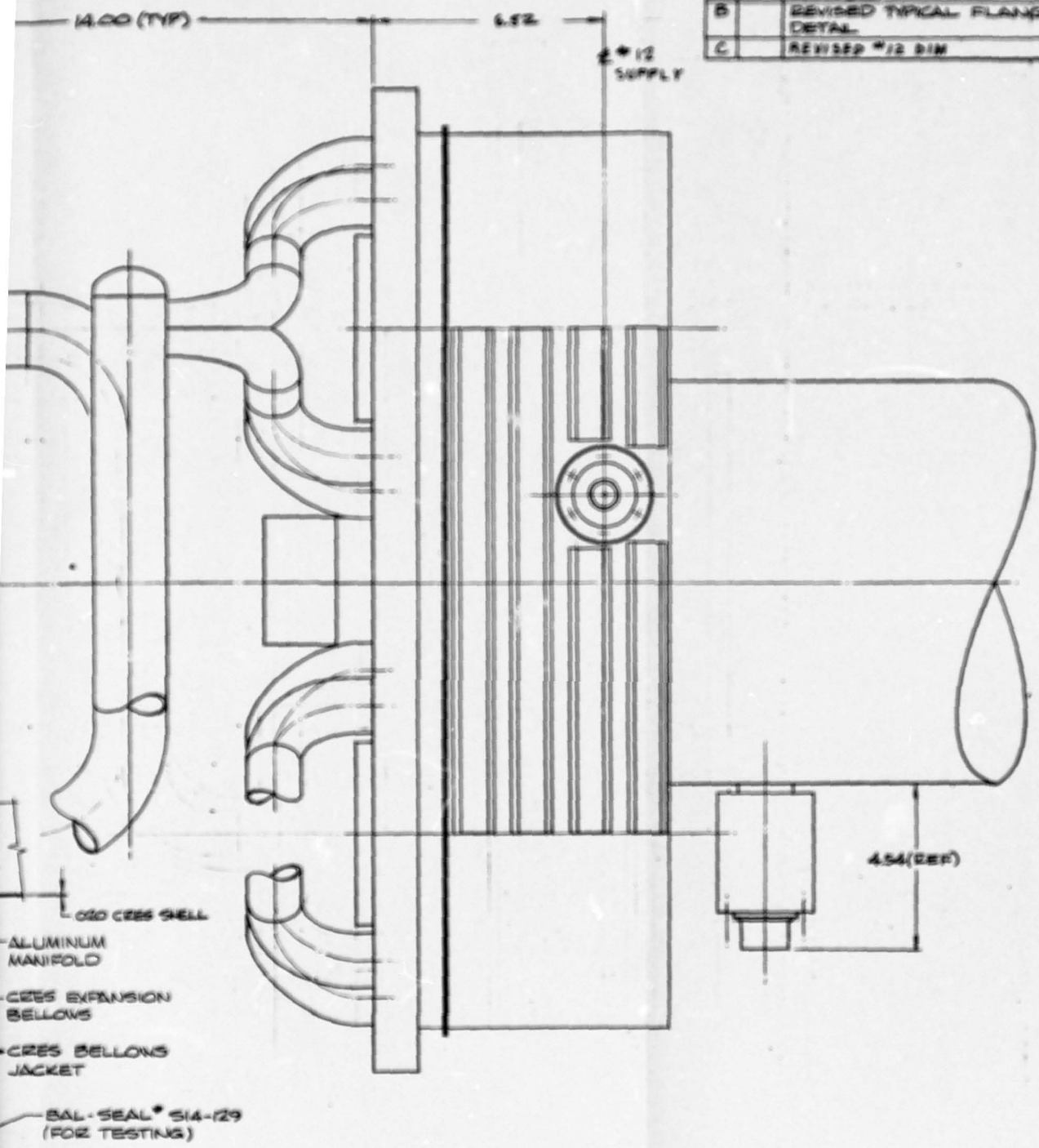

Figure 3-3

QTY REQD		QTY REQD		ITEM NO.	IDENTIFYING NO.	DESCRIPTION	MATERIAL	SPECIFICATION
LIST OF MATERIAL								
				UNLESS OTHERWISE SPECIFIED		CONTR NO. CP-202B		<b>KINERGETICS INC.</b> THERMAL, CALIFORNIA 91336
				DRILL TOLERANCES		DRAWN G. TAYLOR 12/10/73		
				.040 TO .128 + .002 - .001		CHECK R. ELKAN 2/2/74		LAYOUT - HEAT EXCHANGER SYSTEM
				.128 TO .228 + .003 - .001		ELEC.		
				.228 TO 1/2 + .004 - .001		MECH.		
				3/16 TO 3/4 + .005 - .001		DESIGN		
				MACH FINISH ✓ OR BETTER		APPR.		SIZE CODE IDENT NO. <b>D 51210 L3900</b>
				BREAK SHARP EDGES AND REMOVE ALL BURRS		APPROVED <i>M.P.L.</i> 22 Jan 74		
				DIMENSIONS ARE IN INCHES		SCALE 1/2" = 1"		SHEET 2 OF 2
				TOL. XX ± .05 XXX ± .010		WEIGHT		
				FRACT ± 1/32 ANG ± 0° 30'		DO NOT SCALE DRAWING		

DETAIL

L3900 C

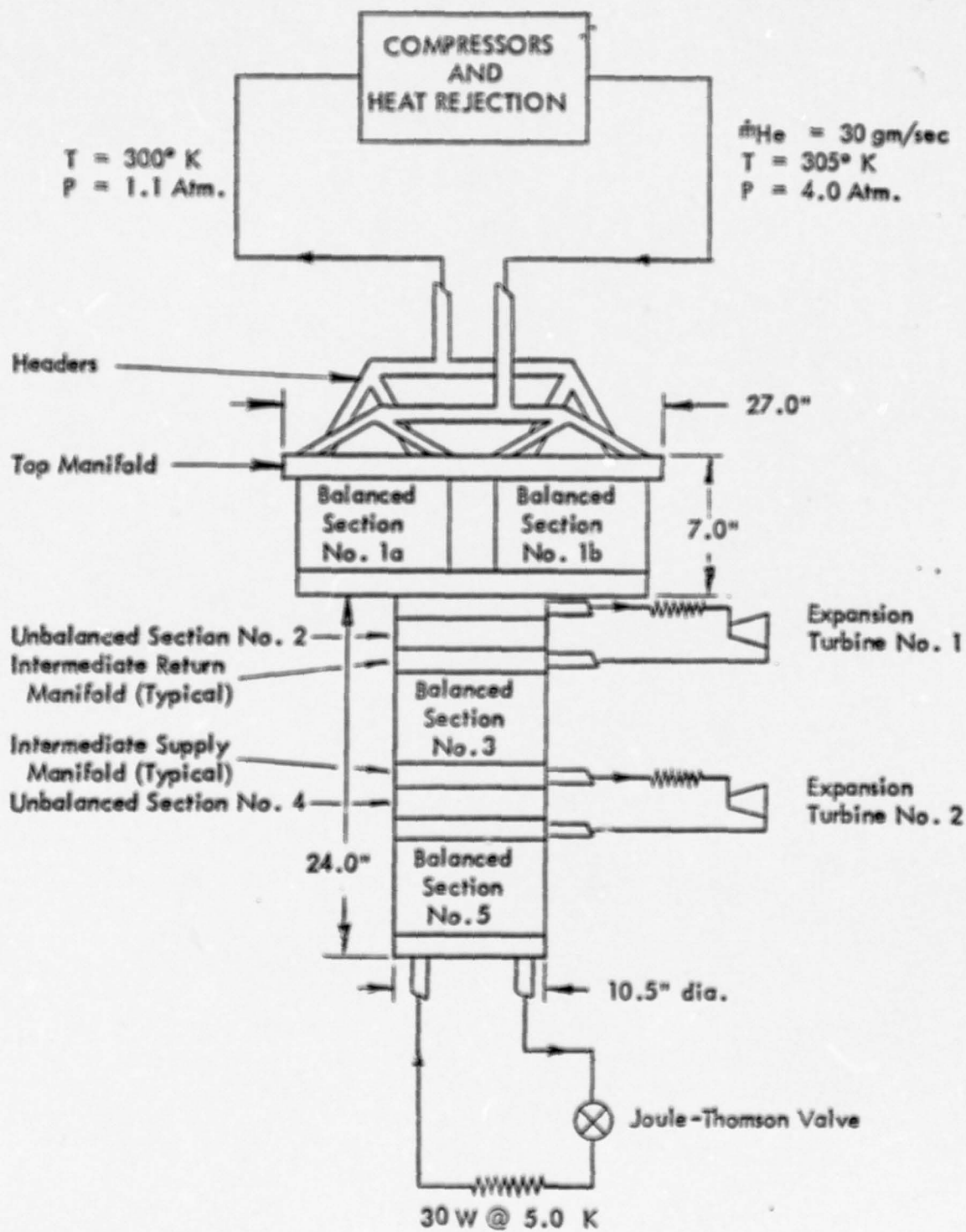

Figure 3-1 - Physical Schematic Diagram of Heat Exchanger

to the outer shell and the other end of the flange on the end of the port tube. Therefore, when the heat exchanger body expands or contracts longitudinally due to temperature changes, the bellows deflect laterally.

### 3.2 Detail Description

Figures 3-2 and 3-3 are the design layout drawings for the heat exchanger assembly. Figure 3-2 shows the overall configuration, while Fig. 3-3 shows the piping and flange details.

As described previously, the warmest balanced flow section is formed by placing two exchanger sections in parallel. Thus, the configuration and fabrication tooling for all the exchanger sections are essentially identical. This can be seen in the layout as the diameter of all the component sections are the same.

The top manifold is designed as a weldment of three items. The two circular ribbed portions which mate to the component sections are designed to be turned on an engine lathe, then welded into a milled housing.

The transitional manifold between the parallel and series components is also designed as a weldment to facilitate the ease of fabrication. As can be seen from the left-hand view in Fig. 3-2, the gas passages from the parallel to series portions are placed at the intersections of the circular manifolds.

It will be observed in the layout that bolts are used to place all of the component sections in overall compression. This has been found to be necessary in all exchangers of this type in order to reduce the stresses placed on the adhesive joints between the component sections and their respective manifolds.

The forces generated by the bolts are transmitted to the exchanger sections through Belleville springs. This is done to accommodate the large amount of longitudinal shrinkage which occurs when the assembly is cooled to operational temperature.

The bolts are machined from Inconel bar. Inconel is used because of its high strength so that cross-sectional area and thus longitudinal conduction can be held at a minimum.

The hollow volume in the center of each component exchanger section must be filled with insulating material, such as refrasil, to prevent convection currents from increasing the apparent longitudinal heat conduction.

The design of the piping arrangement for the inlet and outlet at the top of the assembly is shown in Fig. 3-3. The objective here is to achieve equal flow distribution for both the inlet and outlet flows.

The detail design of a typical port (there are six such ports) is pictured in Fig. 3-3. The port tube is flanged and threaded at the manifold end. There is a groove for a Bal-seal at the manifold to seal the joint. The seal at the shell around the exchanger is continued at the port through the use of a flexible steel bellows. The use of a bellows is essential to accommodate the longitudinal motion of the plastic exchanger with respect to the steel shell during operational cooldown.

It will be noted that the total assembly is designed to have all external joints welded at final assembly. This is done to achieve the objective of absolute helium leak tightness since the assembly is designed to fit into a vacuum chamber in the final system.

## 4.0 FABRICATION PROCESS

### 4.1 General Description

Fabrication procedures for the wire mesh screen and plastic heat exchanger modules are basically very simple. A thermosetting material (Narmco Metlbond 1113) is used in conjunction with wire mesh screen for construction. The die-cut Narmco parts, which contain all of the flow passages, conform to the designed cross-sectional dimensions of the module. The screen parts are die-cut to conform to the exterior cross-sectional dimensions of the module. In preparation for stacking the sandwich, the screen parts are put through a cleaning process to degrease and etch their surfaces.

Each epoxy-resin type plastic part is carefully aligned and pressed onto a screen part with a fixture used to aid in this procedure. Each new plastic-screen pair (referred to as a lamina) is carefully checked against a master lamina to ensure its uniformity. Limits are established as to allowable variation in lamina dimensions and any lamina not within these limits is rejected.

A pressing fixture is utilized to fabricate the finished heat exchanger module. The fixture is basically a container whose inner dimensions are close to the exterior cross-sectional shape of the module, with a hydraulic cylinder and piston mounted on one or both ends. The fixture has two basic functions, the first of which is to compress the stack of parts within it. A unit loading of 160 to 180 psi on the cross-sectional face of the parts stack is used. The second function of the fixture is to heat the stack to the required cure or flow temperature of the plastic. This may be accomplished either by circulating hot fluid through the fixture walls and core or enclosing the complete fixture in an oven.

Each part of lamina is stacked in the pressing fixture, one on top of the other, to form a multilayered sandwich of alternating screen and plastic parts. All parts or lamina are aligned with respect to each other by means of a stacking alignment fixture. During the stacking of parts or lamina, each piece is inspected visually to catch repairable and irreparable flaws. After it is stacked, it is again inspected for alignment with the part beneath it.

After the stack is heated and pressed, it is allowed to cool before removing from the fixture. The outside surfaces and each face are then machined smooth.

Initial leak testing of the module is accomplished by pressurizing each flow passage with nitrogen gas, removing the pressure source from the leak-test system, and observing the decay rate of the gas in the pressurized flow passage. Acceptable decay rates are dependent on the intended use for the heat exchanger.

#### 4.2 Process Refinements Initiated During Project

A large part of the total effort on this program was spent refining various steps in the manufacturing process described in general in the preceding section.

A major factor in adjusting the fabrication process for this program was the type of epoxy laminate material commercially available for use. In previous epoxy plastic heat exchanger assemblies manufactured in the Kinergetics' facility, the epoxy laminate used was Metlbond #252 (manufactured by Narmco materials Corp.). Prior to inception of this project, the Metlbond #252 for which the process had been perfected was discontinued as a commercially available product. A new product, Metlbond #1113, was manufactured as a replacement. This change necessitated a re-evaluation of the exchanger section design and fabrication technique. Since the thickness of the new material was different, the thickness and/or porosity of the screen material which could be utilized to form a leak-tight section changed. Therefore, a search for theoretically correct screens and a production evaluation program was required to proceed with the new Narmco material. A number of usable screen wire and mesh sizes are available commercially and the particular selection is dependent on the  $NTU/\Delta P$  and  $NTU/\text{volume}$  considerations of the system. The screen must be chosen to present a unit area void volume slightly less than the unit area volume of a sheet of plastic. The Metlbond #1113 sheet is approximately 0.010 inch thick and some available screen sizes that meet this criterion are listed in Table II. Sections with acceptable leak-tightness were fabricated from the screen sizes marked with an asterisk.

A second effect of the above material change was the differing cure requirements and behavior of the new epoxy. Significant experimentation was required to determine the correct process temperatures and times. A serious problem surfaced

Table II  
Wire Screens Usable with 0.010-Inch-Thick Plastic

Mesh	Wire diameter, in.	Void. Fract.	Effective thickness, in.	Hydraulic radius $r_h$ , in.
60*	0.0075	0.615	0.0092	0.00300
60	0.0070	0.645	0.0090	0.00318
60	0.0650	0.675	0.0088	0.00340
60	0.0060	0.700	0.0084	0.00350
55	0.0070	0.678	0.0095	0.00370
65	0.0070	0.610	0.0085	0.00274
60-50	0.0075	0.645	0.0097	0.00340
55-60*	0.0075	0.620	0.0092	0.00320
50-60	0.0065	0.704	0.0091	0.00390

\*Indicates that sections with acceptable leak-tightness have been fabricated from the given screen size.

as a tendency of the plastic to "bubble" under vacuum (formerly used in the process) and fixtures and methods of pressurizing the chamber with Helium had to be devised. This pressurization with inert gas cured the porosity problem.

Previous exchangers of the larger (10-1/2 inch) cross section had been fabricated from Polystyrene plastic. This was replaced by the Narmco for a number of reasons (principally overall section strength and reliable attachment of the manifolds during thermal cycling and at very low temperatures). Use of the Narmco necessitated several changes in the assembly procedures, however. Lamina cut from Narmco (which is a soft pliable material at room temperature) do not hold their shape well. It was therefore necessary to fabricate holding fixtures which positioned the lamina strips while the screen sections were lightly pressed on the plastic. This fixture, with a lamina installed and its protective covering partially peeled back, is shown in Figure 4-1.

It was also found to be necessary to lay the raw Narmco sheet on sheets of contact paper before punching. This produced good sharp edges on the lamina, and the contact paper facilitated handling. It was necessary, however, to chill the Narmco to remove the paper.

Since the wall sections of the lamina were relatively thin (to produce the maximum performance), alignment of the total part became critical. A viewing fixture was produced which allowed the assembled screen-lamina part to be placed in the pressing fixture and aligned with a reference pattern to make certain that all parts would be in alignment when finally assembled.

During the course of the program, significant variations in some properties of the Narmco between batches was noticed. A particularly important characteristic was the "tackiness" at room temperature. If the Narmco is not tacky, it will not stick to the screen, and the assembly process does not work. Discussions with the Narmco manufacturer revealed that the variations were random (a function of the specific gravity of the resin) and were not closely controlled because this property was not of great importance to the majority of their customers. It was finally determined that the lamina-screen assemblies could be formed with non-tacky Narmco by first heating the screens and plates in an oven and then lightly pressing the assemblies together.

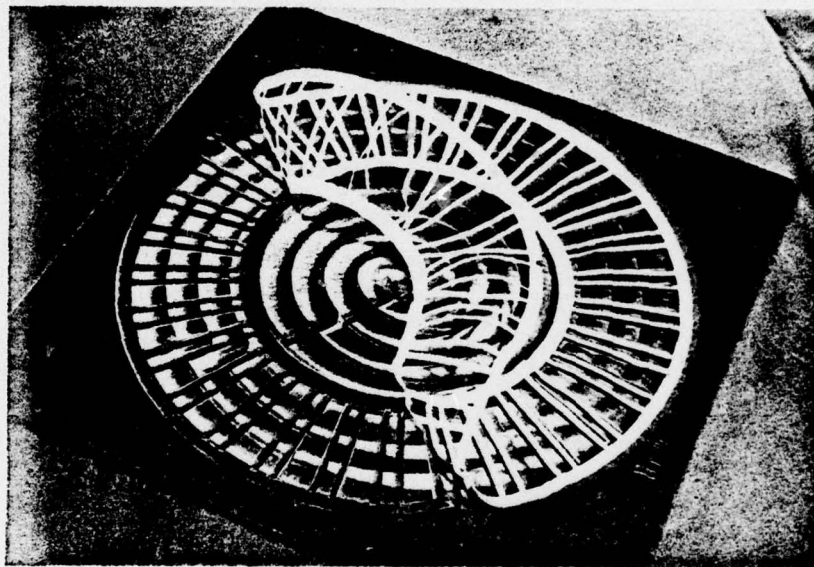
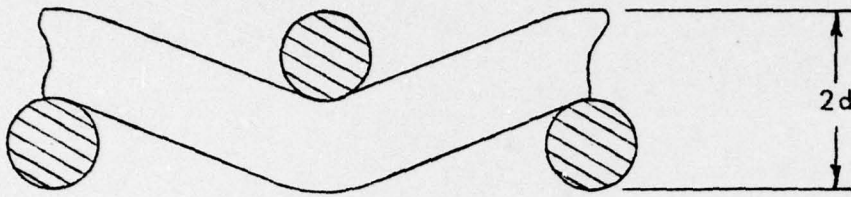

Figure 4-1 - Lamina Fixture with Lamina Installed

A final problem, which appeared at the end of the program, was a variation in screen thickness due to production tolerances. Wire mesh screen is formed from a grid of wires woven alternately over and under a perpendicular wire grid. If the weaving is done in such a manner that the deflection of the mutually perpendicular wires is equal, then a cross-section is obtained as shown in Figure 4-2a. The total thickness of this screen is then seen to be 2 x wire diameter. If, however, one set of wires remains straight, the cross-section becomes as shown in Figure 4-2b, and the total thickness is 3 wire diameters. Since the volume of wire is the same in either case, the effective void volume will vary by 50%.

The pressures exerted by the fabrication fixture are not sufficient to compress the screen to the 2 wire diameter thickness. Therefore, unless the screen is woven with a uniform crimp, the void volume will be too great, and the plastic will not fill the gaps, creating leakage paths.

It was determined, after lengthy discussions with screen manufacturers, that screen is specified only as to wire diameter and mesh, and the above thickness variations can occur randomly. Since it is not feasible for the plastic manufacturer to vary his thickness (except in large special orders), only the screen may be varied. It is therefore required that the screen be specially selected for thickness to allow usage in this exchanger fabrication process. It is expected that obtaining screen of the proper mesh, wire diameter, and thickness will be extremely difficult.



(a) Properly Formed

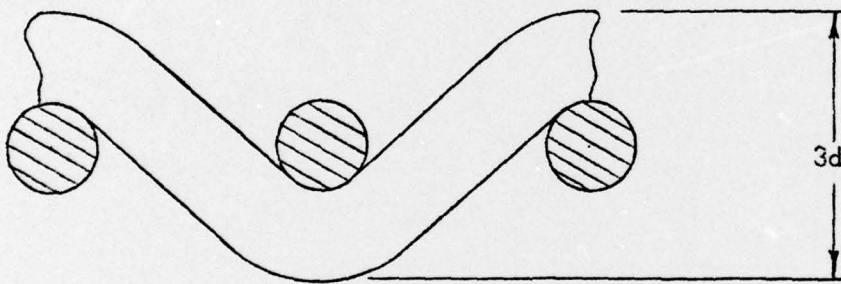

(b) Improperly Formed

Figure 4-2 - Examples of Variation in Thickness of Woven Screen

## 5.0 CONCLUSIONS AND RECOMMENDATIONS

As stated previously, the objectives of this program were to demonstrate the feasibility of fabricating a wire screen and plastic composite heat exchanger and to utilize the manufacturing process to fabricate a set of compact high-performance cryogenic heat exchangers. The objective of demonstrating the feasibility of manufacturing the component sections of this type was achieved. Several leak-tight sections were manufactured utilizing the process developed during the project. Due to the amount of effort expended in developing the manufacturing techniques, it was not possible to accomplish the second objective within the scope of the program.

As has been described previously, the manufacturing process which was developed to fabricate the heat exchangers displayed extreme sensitivity to various physical parameters of the materials used in the process. As a result, most of the effort expended on the project was spent in developing techniques to desensitize the process to the greatest extent possible.

It is recommended that if such a project be undertaken in the future, that effort be included in the project to generate the necessary materials specifications to which the raw materials would be procured. This would possibly increase the projected cost and leak time over past projections, but would vastly improve the process yield and production rate.

APPENDIX A  
PURCHASE DESCRIPTION  
FOR A SET OF  
CRYOGENIC HEAT EXCHANGERS

1.0        Scope of Work

This Purchase Description covers the design, fabrication, and test of a set of compact, high-performance, cryogenic heat exchangers. The set of heat exchangers is required as a major component in an advanced design multi-stage Claude cycle cryogenic refrigeration system.

2.0        Objectives

The work specified in this Purchase Description has the following objectives:

- 2.1        To demonstrate the feasibility of manufacturing compact heat exchangers by bonding wire screens into low thermal conductivity material.
- 2.2        To fabricate a set of compact, high-performance, cryogenic heat exchangers suitable for integration into a Claude cycle refrigeration system.

3.0        General

Advanced multi-stage Claude cycle cryogenic refrigeration systems, using helium gas as the refrigerant, are being designed to run for at least 2,000 hours without major maintenance. To be compatible with these systems, the design life of the set of heat exchangers will be at least 2,000 hours. The heat exchangers will also be designed for high-effectiveness and low volume. While carrying out this work, the contractor will coordinate closely with U. S. Army technical representatives to provide for the successful integration of the heat exchangers with the other components of the system.

#### 4.0 Procedure

The following procedure shall be used:

#### 4.1 Heat Exchanger Specifications

The advanced multi-stage Claude cycle refrigeration system will consist of at least one expansion turbine and Joule-Thomson valve. The system is expected to operate between room temperature and 4.4 K with a pressure ratio across the room temperature compressor of approximately 4. The overall mass flow into the warmest heat exchangers will be approximately 40 g/sec. The set of compact, high-performance heat exchangers will operate between 300 K and 10 K. The balanced flow effectivenesses of the individual heat exchangers comprising the set will be in the range from 98% to 99%. The ratio of the cold-side pressure drop to the inlet cold-side pressure for the set of heat exchangers will not exceed 5%. The flow passages of the heat exchangers will be designed to minimize flow maldistributions which can limit effectivenesses to below the required range of 98 to 99%. The volume of the set of heat exchangers will be kept as small as possible consistent with the other proceeding specifications. It is recognized that some changes in the proceeding specifications may be desirable in order to insure the successful fabrication of the set of heat exchangers and the integration of them with other components. The final heat exchanger specifications will be determined at a meeting with the Army technical representatives no later than three weeks after the effective date of the contract.

#### 4.2 Headers

In addition to the individual heat exchangers, headers shall be provided to permit:

- 1) expansion turbines to be attached in parallel with unbalanced flow heat exchangers,
- 2) the Joule-Thomson valve to be attached directly to the cold end of the bottom balanced flow heat exchanger, and
- 3) the warm end of the top balanced flow heat exchanger to be attached to a room temperature flange.

The warm end header shall permit the set of heat exchangers to be rigidly supported from a room temperature flange and shall be the only means of support for the heat exchangers. The details of the rigid support will be worked out with the Army's technical representatives. The headers will be designed to minimize flow maldistributions which limit the thermal performance of the heat exchangers.

#### 4.3 Structure

The set of heat exchangers and headers shall be fabricated as a single unit and shall be the principal structural member of the refrigeration system. Whenever practical, components will be directly suspended from the heat exchangers to minimize heat leaks due to externally supporting components from the room temperature flange.

#### 4.4 Component Attachment

The expansion turbines and the Joule-Thomson valve shall be attached to the appropriate headers by means of demountable vacuum seals. The Army shall supply stainless steel flanges with Indium O-rings for this purpose. The flat flanges shall be welded to the headers. The size of the intermediate pipes between the flat flanges and the headers shall be chosen by the Army on the basis of providing rigid mechanical strength for possible component support and minimizing pressure drops in these pipes. Similar flanges and pipes shall be welded to the warm end header to enable the set of heat exchangers to be connected to a room temperature compressor.

#### 4.5 Cleanliness

Cleanliness procedures shall be observed during assembly. Heat exchanger parts and headers shall be degreased and ultrasonically cleaned before assembly. The set of exchangers shall be packaged for shipping in a clean heat-sealed plastic bag with dry nitrogen packed inside.

#### 4.6 Thermal Cycling

Before leakage testing, each heat exchanger shall be cycled between room temperature and liquid nitrogen temperature at least three times. Each cycle must be performed in less than one hour. The cycling may be performed by completely submerging the heat exchangers in liquid nitrogen.

#### 4.7 Cryogenic Free Flow Test

The pressure drop across the entire set of heat exchangers shall be measured with helium gas flowing at not less than 0.5 g/sec while the warm end is maintained at room temperature and the cold end is maintained at liquid nitrogen temperature. This measured pressure drop shall be less than the pressure drop measured with helium gas flowing at the same mass flow rate across the same experimental set-up at room temperature.

#### 4.8 Stream-to-Stream Leakage

After performing 4.6 and 4.7, the stream-to-stream leakage shall be measured in the set of heat exchangers at room temperature. With all parts of the headers blocked, except for one part on each side, the exchangers shall be pressurized on one side with helium gas at 20 psig. The other side shall be evacuated and sealed. The pressure vs. time shall be measured for at least 24 hours. An acceptable leakage rate will be  $1 \times 10^{-3}$  atm - cm<sup>3</sup>/sec, which is approximately bubble tightness.

#### 4.9 External Leakage Test

Leaks through the outer walls of the set of heat exchangers shall be measured with a helium mass spectrometer having a sensitivity of at least  $10^{-8}$  Torr-liters/ sec. The external leakage test shall be performed after 4.6 and 4.7. A vacuum tight enclosure, surrounding the set of heat exchangers, shall be connected to the leak detector. This test shall be performed at room temperature. The inside volume of the set of heat exchangers shall be flushed with nitrogen gas to remove residual helium gas which would cause a background reading to occur on the leak detector and erroneously indicate leakage. Nitrogen and helium gas alternately will be introduced into the heat exchangers while the leak detector readings are monitored. Any leaks located in this manner shall be repaired.

#### 4.10 Pressure Drop Test

Both streams of each heat exchanger in the set shall be tested with nitrogen gas flowing at room temperature and near atmospheric pressure. A pressure drop vs. mass flow rate curve for each heat exchanger shall be determined.

#### 4.11 Final Report

The report shall contain the design and test data of the set of heat exchangers designed and fabricated under this contract. Appropriate drawings and documentation will be provided to fully describe the heat exchangers.

5.0 Design Approval

Prior to initiating fabrication of the heat exchangers and headers, the Contractor shall submit to the U. S. Army Technical Representative at Fort Belvoir, Virginia

Commander  
U. S. Army Mobility Equipment R&D Center  
Attn: SMEFB-EA (Contract No. DAAK02-73-C-0323)  
Fort Belvoir, Virginia 22060

for approval drawings and design data in sufficient detail to completely describe the design of the set of heat exchangers and the expected performance. Approval of the drawings and design data will indicate that no obvious defects are evident in the data submitted and this approval shall in no way relieve the contractor of the responsibility for supplying a set of heat exchangers meeting the specifications of the purchase request. The contractor shall proceed to fabricate the set of heat exchangers upon receipt of written approval.