

AD-A033 646

CERL TR-N-15

OCT 76 FLD/GP 13/2 13/3

DEVELOPMENT OF PREDICTIVE CRITERIA FOR DEMOLITION AND CONSTRUCTION  
SOLID WASTE MANAGEMENT. (U)  
BATTELLE COLUMBUS LABS., OHIO.

K.S. MURTHY, ET AL.

UNCLASSIFIED

1 OF 2  
AD-A  
033 646

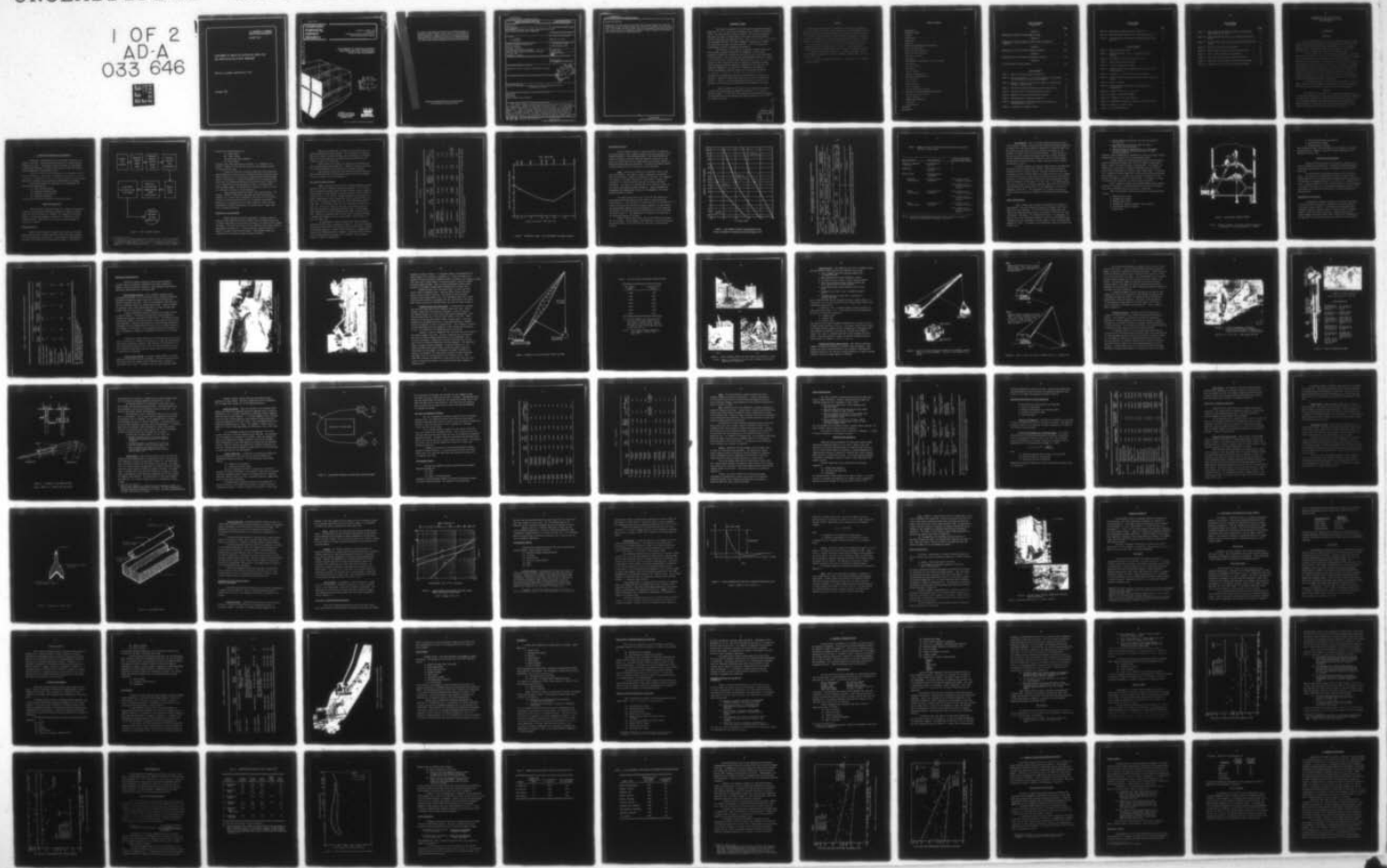

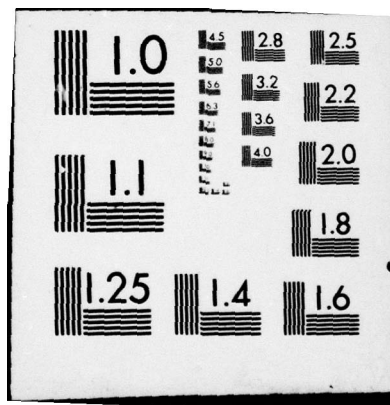

**U.S. DEPARTMENT OF COMMERCE**  
**National Technical Information Service**

AD-A033 646

DEVELOPMENT OF PREDICTIVE CRITERIA FOR DEMOLITION  
AND CONSTRUCTION SOLID WASTE MANAGEMENT

BATTELLE COLUMBUS LABORATORIES, OHIO

OCTOBER 1976

364115

construction  
engineering  
research  
laboratory

TECHNICAL REPORT N-15  
October 1976

Development of Application Tools for Protection  
of the Environment During Construction

ADA033646

DEVELOPMENT OF PREDICTIVE CRITERIA  
FOR DEMOLITION AND CONSTRUCTION  
SOLID WASTE MANAGEMENT

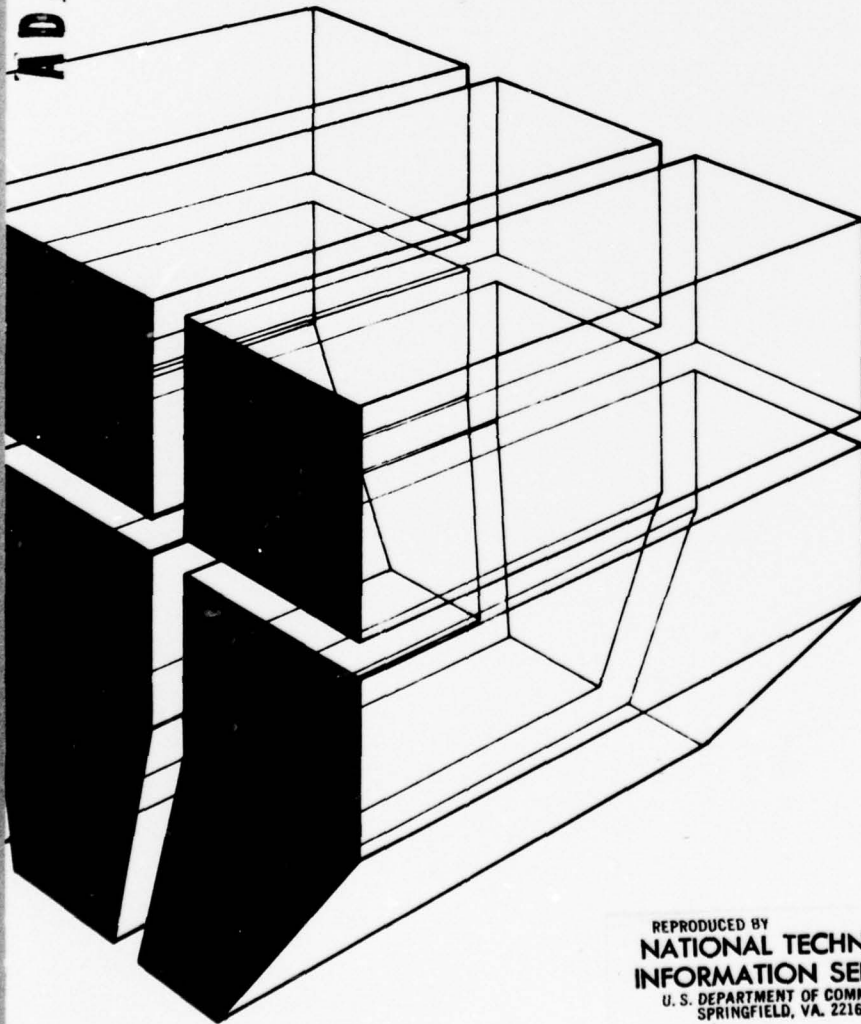

DDC  
RECEIVED  
DEC 22 1976  
RESERVED  
C

REPRODUCED BY  
NATIONAL TECHNICAL  
INFORMATION SERVICE  
U. S. DEPARTMENT OF COMMERCE  
SPRINGFIELD, VA. 22161



Approved for public release; distribution unlimited.

The contents of this report are not to be used for advertising, publication, or promotional purposes. Citation of trade names does not constitute an official indorsement or approval of the use of such commercial products. The findings of this report are not to be construed as an official Department of the Army position, unless so designated by other authorized documents.

***DESTROY THIS REPORT WHEN IT IS NO LONGER NEEDED  
DO NOT RETURN IT TO THE ORIGINATOR***

UNCLASSIFIED

SECURITY CLASSIFICATION OF THIS PAGE (When Data Entered)

REPORT DOCUMENTATION PAGE		READ INSTRUCTIONS BEFORE COMPLETING FORM
1. REPORT NUMBER CERL-TR-N-15	2. GOVT ACCESSION NO.	3. RECIPIENT'S CATALOG NUMBER
4. TITLE (and Subtitle) DEVELOPMENT OF PREDICTIVE CRITERIA FOR DEMOLITION AND CONSTRUCTION SOLID WASTE MANAGEMENT		5. TYPE OF REPORT & PERIOD COVERED FINAL
		6. PERFORMING ORG. REPORT NUMBER
7. AUTHOR(s) K. S. Murthy S. Chatterjee		8. CONTRACT OR GRANT NUMBER(s) DACA 88-75-C-0015
9. PERFORMING ORGANIZATION NAME AND ADDRESS Battelle Columbus Laboratories 505 King Avenue Columbus, OH 43201		10. PROGRAM ELEMENT, PROJECT, TASK AREA & WORK UNIT NUMBERS 4A7627720A896-T2-006
11. CONTROLLING OFFICE NAME AND ADDRESS CONSTRUCTION ENGINEERING RESEARCH LABORATORY P.O. Box 4005 Champaign, IL 61820		12. REPORT DATE October 1976
		13. NUMBER OF PAGES 141
14. MONITORING AGENCY NAME & ADDRESS (if different from Controlling Office)		15. SECURITY CLASS. (of this report)  Unclassified
		15a. DECLASSIFICATION/DOWNGRADING SCHEDULE
16. DISTRIBUTION STATEMENT (of this Report)  Approved for public release; distribution unlimited.		
17. DISTRIBUTION STATEMENT (of the abstract entered in Block 20, if different from Report)		
18. SUPPLEMENTARY NOTES Copies are obtainable from National Technical Information Service Springfield, VA 22151		
19. KEY WORDS (Continue on reverse side if necessary and identify by block number) demolition solid waste waste salvage and reclamation		
20. ABSTRACT (Continue on reverse side if necessary and identify by block number) This report presents a detailed review of existing demolition techniques and alternatives. Demolition techniques discussed include: (1) manual wrecking, (2) mechanical demolition, (3) demolition with explosives, and (4) underwater demolition. Types of equipment employed for each technique are described in detail. The operating features, applicability of the demolition method, cost data, environmental impacts, and safety considerations associated with each technique are detailed. The salvage and reclamation aspects of demolition waste are explained. Data collected by field visits to several Army and civilian		

**D D C**  
**RECEIVED**  
 DEC 22 1976  
**REC'D**

UNCLASSIFIED

SECURITY CLASSIFICATION OF THIS PAGE(When Data Entered)

Block 20 continued.

demolition sites are tabulated and analyzed to present predictive tools for estimation of waste volume, composition, and cost of disposal for a given project. Waste data from construction sites are presented and analyzed similarly. This study is the first documented systematic study of demolition techniques and can be considered a pioneering effort.

UNCLASSIFIED

SECURITY CLASSIFICATION OF THIS PAGE(When Data Entered)



FOREWORD

This study was sponsored by the Directorate of Military Construction, Office of the Chief of Engineers (OCE) under Project 4A7627720A896, "Environmental Quality for Construction and Operation of Military Facilities"; Task T2, "Pollution Control Technology"; Work Unit 006, "Development of Application Tools for Protection of the Environment During Construction." The QCR number is 1.03.006(2). The OCE Technical Monitor was Mr. Peter Van Parys.

The work was performed by K. S. Murthy and S. Chatterjee of Battelle's Columbus Laboratories, Columbus, Ohio, for the U. S. Army Construction Engineering Research Laboratory (CERL) under Contract No. DACA 88-75-C-0015.

The CERL Technical Monitor was Mr. W. J. Mikucki, Team Leader of the CERL Environmental Engineering Team, Environmental Division (EN). Dr. R. K. Jain is Chief of EN.

COL J. E. Hays is Commander and Director of CERL, and Dr. L. R. Shaffer is Deputy Director.

TABLE OF CONTENTS

	<u>Page</u>
DD FORM 1473	i
MANAGEMENT SUMMARY	iii
FOREWORD	iv
1. INTRODUCTION . . . . .	1
Background . . . . .	1
Objective . . . . .	1
2. DEMOLITION TECHNIQUES AND ALTERNATIVES . . . . .	2
Manual Wrecking Method . . . . .	2
Mechanical Wrecking Methods . . . . .	15
Demolition with Explosives . . . . .	38
Underwater Demolition . . . . .	55
Conclusions . . . . .	55
3. ENVIRONMENTAL CONSIDERATIONS IN WASTE DISPOSAL . . . . .	56
Open Burning . . . . .	56
Controlled Burning . . . . .	56
Open Dumping . . . . .	57
Sanitary Landfill . . . . .	58
Salvage and Reclamation . . . . .	58
4. ANALYSES OF DEMOLITION DATA . . . . .	66
Data Collection . . . . .	66
Data Analyses . . . . .	68
Volume of Waste . . . . .	69
Waste Composition . . . . .	73
Cost of Solid Waste Disposal . . . . .	73
5. ANALYSIS OF DATA FROM CONSTRUCTION PROJECTS . . . . .	82
Data Collection and Analysis . . . . .	82
Cost of Disposal . . . . .	84
6. SUMMARY AND CONCLUSIONS . . . . .	85
Conclusions . . . . .	86
Recommendations . . . . .	88
REFERENCES . . . . .	89
BIBLIOGRAPHY . . . . .	91

TABLE OF CONTENTS  
(Continued)

	<u>Page</u>
APPENDIX A	
ABATEMENT AND CONTROL OF ENVIRONMENTAL IMPACTS . . . . .	94
APPENDIX B	
DESCRIPTION OF SELECTED DEMOLITION AND SALVAGE EQUIPMENT AND METHODS . . . . .	103
APPENDIX C	
COMPILATION OF DATA ON SELECTED DEMOLITION PROJECTS . . . . .	106
APPENDIX D	
COMPILATION OF DATA ON SELECTED CONSTRUCTION PROJECTS . . . . .	120
APPENDIX E	
LIST OF CONTACTS AND DATA SOURCES . . . . .	126

LIST OF TABLES

Table 1. Summary of Typical Manual Wrecking Costs . . . . .	6
Table 2. Factors Considered in the Four Major Methods for Describing The Intrusiveness of Noise on the Community . . . . .	10
Table 3. Example of Limits on Noise from Buildings and Installations (Chicago, Illinois, Data) . . . . .	11
Table 4. Mechanical Wrecking Techniques and Their Applicability . .	16
Table 5. Cost Data (1975) on Semisteel Demolition Balls . . . . .	22
Table 6. Summary of Cost Data for Mechanical Wrecking . . . . .	35
Table 7. Characteristics of Explosive Categories . . . . .	39
Table 8. Characteristics of Principal Military and Nonmilitary Explosives Used in the U.S. . . . .	41
Table 9. Information on Salvage of Bricks . . . . .	60

LIST OF TABLES  
(Continued)

	<u>Page</u>
Table 10. Representative Demolition Waste Composition . . . . .	74
Table 11. Demolition Waste Disposal Costs at Selected Army Posts . .	77
Table 12. Cost Adjustment Factors Based on Engineering News-Record Indices . . . . .	78

LIST OF FIGURES

Figure 1. Steps in Manual Wrecking . . . . .	3
Figure 2. Approximate Volume - Cost Relationship for Manual Wrecking . . . . .	7
Figure 3. HUD Proposed Criteria for Nonaircraft Noise . . . . .	9
Figure 4. Unsafe Manual Wrecking Methods . . . . .	14
Figure 5. A Typical Demolition Scoopdozer . . . . .	18
Figure 6. Excavator with 20-Foot Grappling Boom Used to Pull Down Arcade Building . . . . .	19
Figure 7. Schematic of a Typical Gravity Impact Equipment . . . . .	21
Figure 8. Typical Clamshell Bucket and Crane Demolition Equipment in Action . . . . .	23
Figure 9. View of a Tagline . . . . .	25
Figure 10. Steps in Aiming and Casting a Wrecking Bucket or a Wrecking Ball . . . . .	26
Figure 11. A Typical Hob-knocker in Operation . . . . .	28
Figure 12. Typical Air-Demolition Hammer . . . . .	29
Figure 13. A Schematic of the DARDA Splitter . . . . .	30
Figure 14. Drag-Through Technique for Demolishing Frame Structures .	33
Figure 15. Schematic of Shaped Charge . . . . .	44
Figure 16. Linear-Shaped Charge . . . . .	45

LIST OF FIGURES  
(Continued)

	<u>Page</u>
Figure 17. Crater Dimension and Required Explosive Charge-Weight Relationship for Dry Rock . . . . .	48
Figure 18. Typical Pressure-Time Curve for an Explosion Blast Wave in Air . . . . .	51
Figure 19. The Fort Wayne, Indiana, Keenan Hotel Explosive Demolition Project . . . . .	54
Figure 20. Mechanical Brick Salvaging Equipment . . . . .	61
Figure 21. Waste Volume and Volume of Structure Relationship . . . . .	70
Figure 22. Waste Volume and Floor Area Relationship . . . . .	72
Figure 23. Cost of Disposal and Waste Volume Relationship . . . . .	75
Figure 24. Demolition Cost and Volume of Structure Relationship . . . . .	80
Figure 25. Demolition Cost and Total Floor Area Relationship . . . . .	81

DEVELOPMENT OF PREDICTIVE CRITERIA  
FOR DEMOLITION AND CONSTRUCTION SOLID  
WASTE MANAGEMENT

1. INTRODUCTION

Background

The U.S. Army engages in a variety of demolition projects, mainly at its Army installations, which are widely spread across the nation. The demolition of old barracks, mess halls, pavements, etc., is a necessary component of the continuously changing needs of the Army. Most of the demolition work is carried out to make room for new structures.

A tool to predict the cost and duration of completing a particular demolition project would be very useful for the engineer in charge of budgeting for such demolition and construction projects. Also important is a knowledge of: (1) the methods of estimating the amount of solid wastes generated, and (2) how they can best be disposed of. The need for reclaiming the salvageable portion of the waste is increasing. This report describes the salvage and reclamation techniques used by the Army and provides a detailed description of the various techniques and methods for optimally planning the demolition of a given structure. The environmental ramifications of each demolition technique are fully described as are the methods of meeting environmental regulatory requirements.

It is hoped that the U.S. Army will find opportunities to use the simple predictive tools presented in this report. Based on the experience which may be gained during their usage, these tools can be improved.

Objective

The objective of this study is to define the significant aspects of construction and demolition solid waste generation and disposal, including: (1) waste volume generated, (2) demolition and waste disposal costs, and (3) environmental problems associated with demolition and construction. Another objective is to develop tools for predicting solid waste volume and costs associated with construction/demolition activities.

## 2. DEMOLITION TECHNIQUES AND ALTERNATIVES

Demolition technology deals with the methods of destruction of obsolete structures. Structures become obsolete due to their being old, outdated, and unsafe. Increasingly, modern technology is being applied to demolition techniques to improve the efficiency, safety, and environmental compatibility of demolition methods.

Since very little, if any, documentation of the demolition techniques is available, a need exists to document the alternatives. A documented body of knowledge which can be continuously updated to reflect modern principles, techniques, and technological breakthroughs is desirable.

The available demolition techniques can be categorized into four broad wrecking methods:

- (1) Manual wrecking methods
- (2) Mechanical wrecking methods
- (3) Demolition with explosives
- (4) Underwater demolition.

A discussion of these four categories of demolition follows.

### Manual Wrecking Method

Manual wrecking is generally employed in congested (high-density residential and industrial) areas where mechanical or explosive methods could cause serious disruption or damage to the neighboring facilities. Usually, it involves disassembly or demolition of structures by labor-intensive methods. Manual wrecking can result in greater salvage or reclamation of wastes.

### Operating Features

Manual wrecking involves systematic hand removal of materials from a given structure. Valuable materials that can be easily separated are first removed from the structure. A typical manual wrecking project proceeds in accordance with the steps shown in Figure 1. The order of

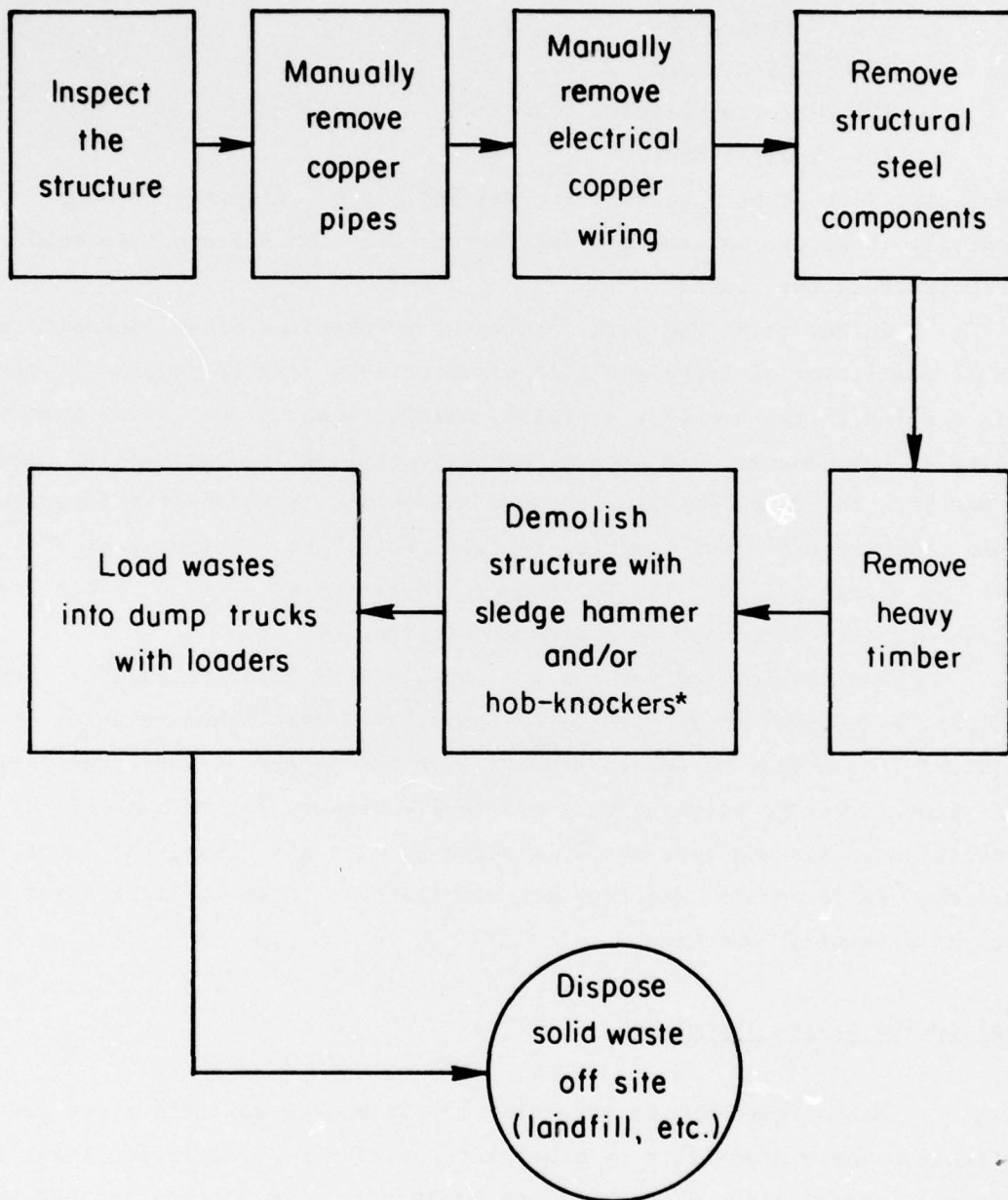

FIGURE 1. STEPS IN MANUAL WRECKING

\* A hob-knocker is a crawler-mounted device classified as mechanical equipment but used occasionally for demolition of high-rise buildings as a superior alternative to sledge hammer. The assembly of a hob-knocker shown in Figure 11 weighs up to 4 tons and is properly defined as a mechanical demolition device.

priority for removing materials is

- (1) Copper pipes
- (2) Copper wiring
- (3) Structural-steel components
- (4) Heavy timber.

Presently, most other materials are rejected, i.e., disposed of in a landfill. However, on some projects bricks are also salvaged and sold to contractors for reuse.

In New York, New York, stringent regulations often necessitate manual demolition of large and tall structures in heavily populated areas. This has led to the use of a minisize, crawler-mounted demolition hammer called a "hob-knocker". A typical hob-knocker that is occasionally used in New York for demolishing multistory structures is shown in Figure 11. It is a highly efficient wrecking device, about 5 to 10 times faster than the sledge hammer. The hob-knocker is raised by a crane to the top of a multistory structure to effect demolition.

Manual wrecking methods are usually very labor-intensive. For example, a 2000-ft<sup>2</sup> single-family dwelling, when demolished manually, requires 3 to 4 days of labor, depending on the nature of the structure. A similar structure requires only 0.5 to 1.0 man-day for mechanical demolition by a scoopdozer which is shown on page 18. Thus, the labor requirements for manual wrecking may vary between three to eight times that of mechanical wrecking.

#### Application of the Technique

Manual wrecking is generally applicable to specific sites and situations where demolition by other methods cannot be employed either due to severe restrictions on site access or because it can cause serious nuisance and damage. Such sites are usually found in downtown areas, subway sections, underground facilities, etc. In these situations, manual wrecking is a matter of necessity rather than efficiency. When maximum salvage and reclamation is the objective, manual wrecking is helpful.

High-rise buildings that are higher than 15 stories must be partially demolished by manual methods. Use of mechanical or explosive methods for higher multistory buildings can cause serious air pollution and ejecta (ejected particles from demolition sites) problems in the vicinity of these tall structures.

Manual methods are suitable for demolition of buildings with party (nonload-bearing partition) walls. Removal of interior partitions for renovation purposes also requires the use of manual methods.

Recycling and salvage are major benefits of manual demolition. Most valuable materials can be separated manually before the remaining structure is broken up for final disposal.

#### Cost Data for Manual Wrecking

Manual wrecking is one of the most expensive demolition methods. Generally, the cost of manual wrecking has been about 1.5 to 2.0 times that of mechanical wrecking during the 1974-75 period. Table 1 shows the typical costs of manual wrecking at selected projects in five different cities in the U.S. For instance, manual wrecking of 12 structures in a Boston, Massachusetts, urban renewal area could cost about 20 cents per cubic foot of standing building volume or about \$2 per square foot of floor area. This is about double the cost of mechanical demolition for this job. The Detroit, Michigan, data show that about 18 cents per cubic foot is usually a high manual demolition cost. On an average, manual demolition in Detroit, Michigan, costs about 14 cents per cubic foot. However, a structure which is fairly easy to wreck and involves a minimal waste disposal cost can be demolished at the low cost of 9 cents per cubic foot.

The relationship of manual wrecking costs and the volume of structure and floor area is presented in Figure 2. Since this relationship has not been verified by sufficient data from many cities, it should be considered tentative. However, based on Figure 2, it appears that a floor area of 20,000 square feet represents an optimum size for which the cost of manual demolition appears to be a minimum. This conclusion, however, is based on limited data.

TABLE 1. SUMMARY OF TYPICAL MANUAL WRECKING COSTS  
(1975 Data)

Project Location and Date	Project Type	Floor Area, sq feet	Volume of Structure, cu feet	Cost of Demolition and Waste Disposal	Adjusted (a) Unit Cost	
					\$, per sq foot	\$, per cu foot
(1) Boston (3/75)	Residential 12 structures	39,000	390,000	\$ 75,600	1.89	0.189
(2) Chicago (4/75)	Residential 2-family structure	13,200	132,000	13,880	1.01	0.101
(3) Columbus (4/75)	Residential	1,200	12,000	2,065	1.70	0.170
(4) Detroit (4/75)	Residential	2,000 20,000	20,000 200,000	4,000 20,000	1.75 0.68	0.175 (high) 0.088 (low)
(5) New York (5/75)	Residential	164,000	1,640,000	254,000	1.26	0.126

(a) Unit costs have been adjusted to provide a uniform basis for comparison. The available ENR indices (Table 12) have been used for the adjustment.

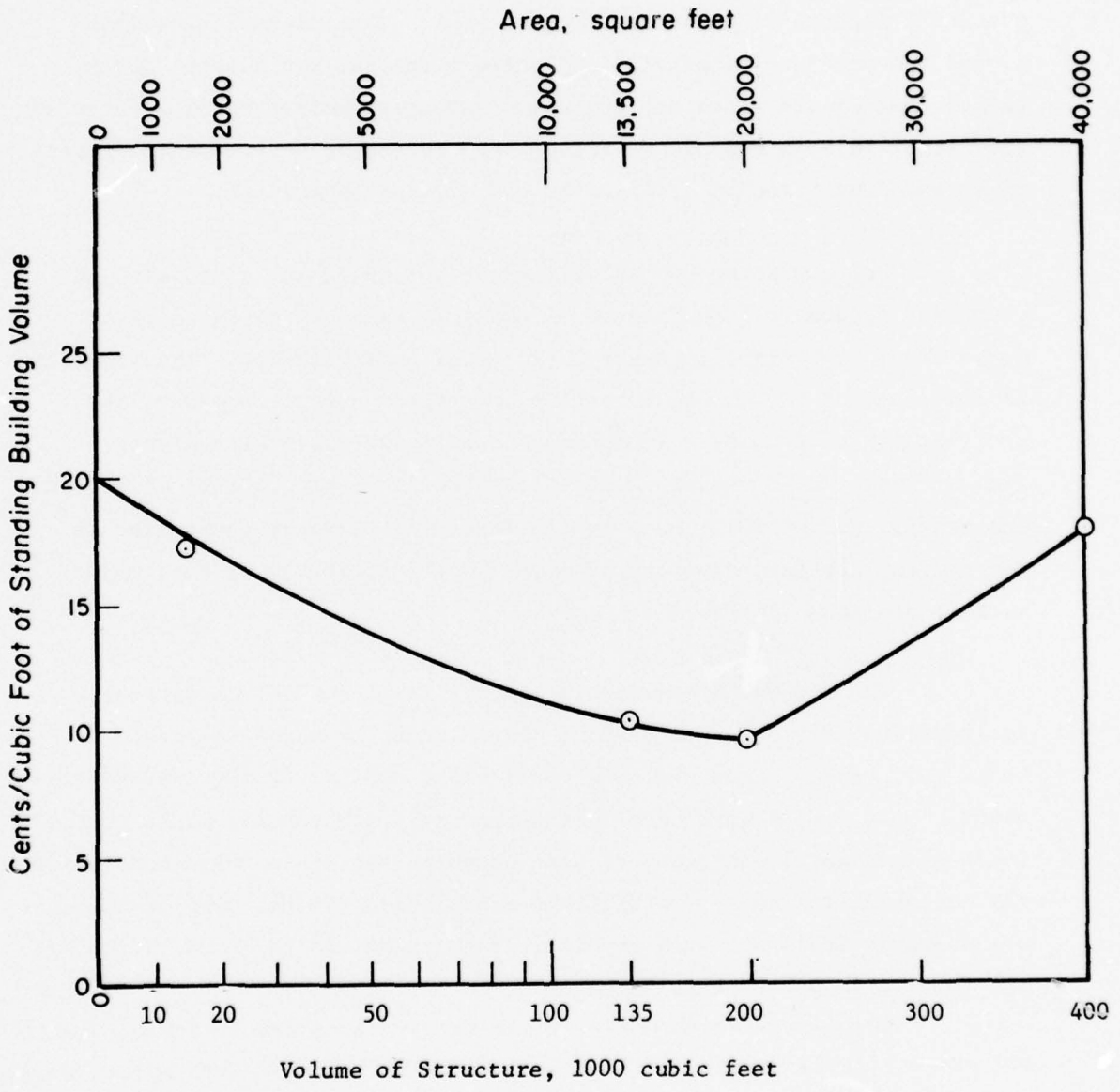

FIGURE 2. APPROXIMATE VOLUME - COST RELATIONSHIP FOR MANUAL WRECKING

### Environmental Impacts

The environmental impacts of manual demolition are generally relatively minimal. Use of manual techniques can help avoid many of the potential impacts of other wrecking methods. Thus, manual demolition avoids the problems of harmful explosion products, air blasts, ground motion, and ejecta which are the common adverse environmental impacts of demolition methods employing explosives. The major environmental impacts of manual demolition are: (1) noise and (2) dust emissions.

Noise. Noise can be defined as an unpleasant sound of high pitch and frequency. The impact of noise is measured by three major sound characteristics: intensity, frequency, and duration. The intensity is a measure of the damage potential of a given noise. However, the irritability of a noise occurrence generally increases with higher frequencies. The duration of exposure also has a significant effect on the overall noise impact as shown in Figure 3. Factors considered in determining the intrusiveness of noise on the community by four major methods are shown in Table 2.

The Federal Noise Control Act of 1972 (PL 574) mandates the Environmental Protection Agency to place limits on major sources of noise pollution. Since the control of noise sources is the responsibility of states, most states have developed necessary standards for noise control. Local governmental agencies are also becoming active in noise regulation. For instance, the noise restrictions established for the city of Chicago are shown in Table 3. Such regulations are required to be satisfied by all demolition projects in Chicago.

Specific data on noise levels from various demolition equipment are not available. Noise mitigation from demolition projects are necessary and initial efforts in that direction are under way in the demolition industry.

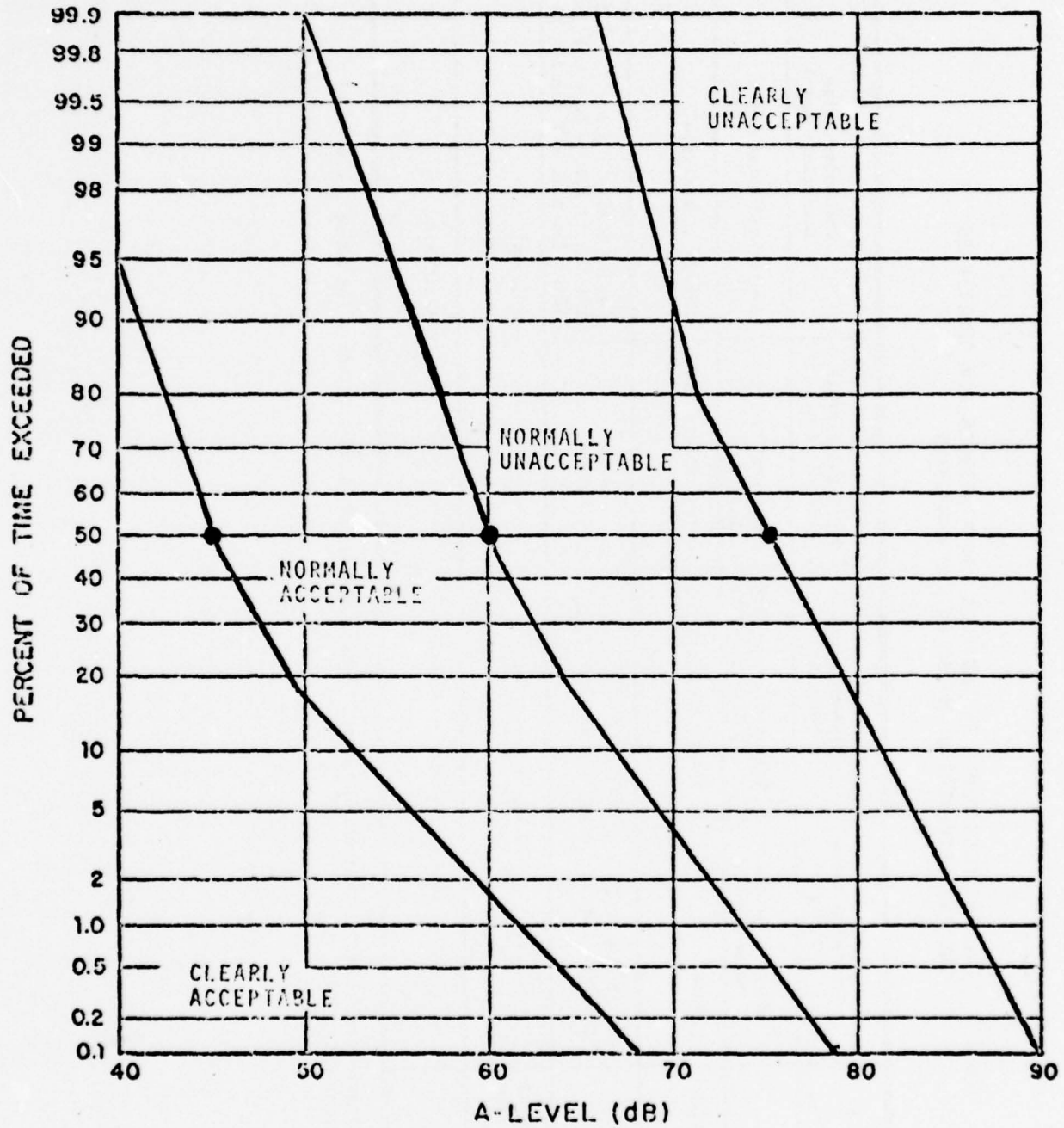

FIGURE 3. HUD PROPOSED CRITERIA FOR NONAIRCRAFT NOISE  
Source: Department of Housing and Urban Development, 1970

TABLE 2. FACTORS CONSIDERED IN THE FOUR MAJOR METHODS FOR DESCRIBING THE INTRUSIVENESS OF NOISE ON THE COMMUNITY

Method Factor	Composite Noise Rating	Noise Exposure Forecast	Day/Night Average Sound Level	Community Noise Equivalent Level
Basic measure	Maximum perceived noise level	Tone corrected perceived noise level	A-weighted noise level	A-weighted noise level
Measure of duration of individual single event	None	Energy integration	Energy integration	Energy integration
Weighting for time period	Day (7 a.m. - 10 p.m.) Night (10 p.m. - 7 a.m.)	0 dB 12 dB	0 dB 10 dB	Day (7 a.m. - 7 p.m.) 0 dB Evening (7 p.m. - 10 p.m.) 5 dB Night (10 p.m. - 7 a.m.) 10 dB
Number (N) of identical events in time period	10 Log N			10 Log N
Summation of contributions	Logarithmic			Logarithmic

Source: United States Environmental Protection Agency, "Public Health and Welfare Criteria for Noise", U.S. EPA, Washington, D.C., July, 1973.

TABLE 3. EXAMPLE OF LIMITS ON NOISE FROM BUILDINGS AND INSTALLATIONS  
(Chicago, Illinois, Data)

Type of District	Where Measured	Limits in dBA Units (For Monitoring Purposes)
Business & commercial districts	At boundaries of the lot	62
Residential	At boundaries of the lot	55
Manufacturing	At zoning district boundaries	
Restricted Manufacturing	At zoning district boundaries	55 On boundary with a residential district
		62 On boundary with a business-commercial district
General Manufacturing	At zoning district boundaries	58 On boundary with a residential district
		64 On boundary with a business-commercial district
Heavy Manufacturing	At zoning district boundaries	61 On boundary with a residential district
		66 On boundary with a business-commercial district

Source: United States Environmental Protection Agency, "Noise Facts Digest", Contract No. 68-01-0152, Final Report, June 1972.

Dust Emissions. Dust is the major emission problem from demolition projects. However, the dust problem resulting from manual demolition is significantly small when compared to mechanical or explosive demolition. Particulate pollution data for various demolition techniques are not available to compare their relative dust potential. A gross estimate is that the total dust emission from manual demolition is about one-third the dust emission from mechanical demolition. Also, in manual wrecking the emissions are distributed over a longer time period; thus, emission concentration is lower.

In manual wrecking, the asbestos concentration in the demolition dust emissions can be significantly reduced. Manual wrecking permits systematic removal of friable asbestos materials (defined as materials containing more than 1 percent asbestos by weight and which can be crumbled by hand when dry) used in construction for insulation and/or fireproofing. The removal of friable asbestos is mandated by the National Emission Standards for Hazardous Air Pollutants (U.S. EPA, 1974). The NESHAP standards also require wetting of all asbestos materials except when: (1) certain air cleaning methods are employed and/or (2) the temperature at the site of stripping is below 32° F. The requirements for removal and wetting of friable asbestos materials are exempted for structurally unsafe buildings only.

#### Safety Considerations

Half a century ago, buildings were demolished by salvage and scrap dealers. The entire demolition operation was manual, and it was a high-injury-rate occupation. For 1974, the yearly average injury and illness rate among demolition workers is reported to be 21.8 per 100 full-time workers; the range is 17-25 workers/100 workers. In comparison, the overall rate in the construction industry is 18.3 and in the manufacturing industries 14.6 (U.S. Department of Labor, Bureau of Labor Statistics News, November 19, 1975). The reasons for the high-injury rates in the demolition industry are:

- Certain demolition contractors are not fully qualified to do the job
- Many demolition projects are unique and require highly specialized techniques
- Careful planning and implementation of a well-thought-out safety program is generally nonexistent in many demolition projects.

A specific action program must be established to insure that these accident-causing factors are eliminated in the best possible manner.

A safety program for manual demolition should be focused around specific situations that might arise and can be judged as being unsafe. Figure 4 shows a few selected unsafe wrecking methods. For instance, at Location (1) in the figure, a workman is operating within the range of ejecta particles generated by a workman using a sledge hammer. At Location (2), a workman is using the same chute to which wastes are being discharged from a higher floor. At Location (3), care must be exercised to avoid exposure of workmen and public to rolling debris. At Location (4), there is a serious risk of being hit by debris and the falling wall.

Brick cleaning is usually done by manual methods without adequate protection for the hand. The high incidence of injury may be prevented by the use of suitable protective gloves and a facial mask.

Many other hazardous situations encountered in manual demolition include:

- Removing corner blocks
- Standing wall sections
- Removing floor arches
- Wrecking pre- and post-tensioned concrete members
- Using unsafe stairs or ladders
- Using chutes

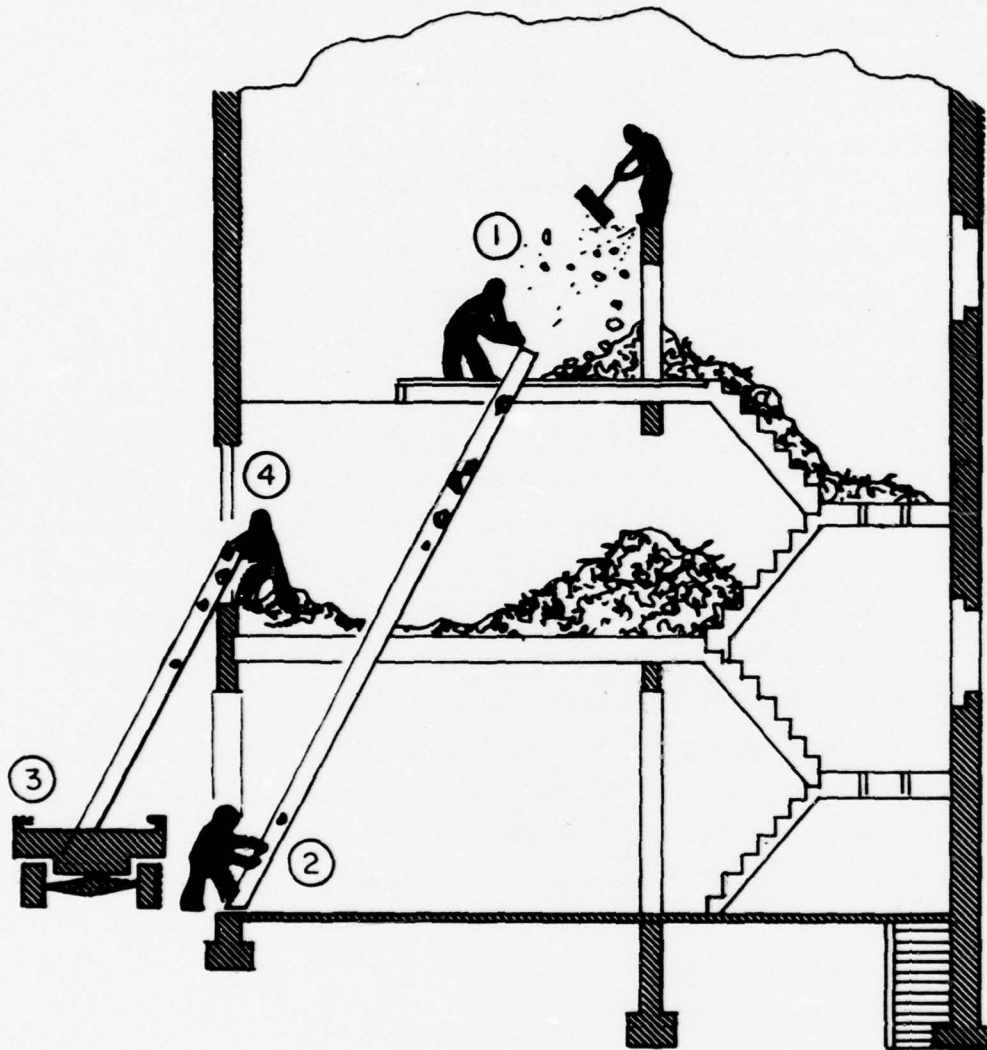

FIGURE 4. UNSAFE MANUAL WRECKING METHODS

Source: "Safety in Industry - Instructor Outline: Demolition,"  
U.S. Department of Labor, Washington, D.C. (1967).

- Erecting sidewalk sheds and openings
- Creating street washings
- Bracing adjacent buildings.

These problems and their corrective measures are discussed in the manual entitled "Safety in Industry - Instructor Outline: Demolition," (U.S. Department of Labor, 1967).

#### Mechanical Wrecking Methods

Mechanical wrecking methods have developed in response to the need for improved labor productivity. Mechanical earth-moving equipment of different types has been introduced to mechanize various demolition operations.

The major mechanical wrecking techniques in use are listed in Table 4. The selection of a demolition technique for a given project depends generally on the wrecking company's experience and the availability (or ownership) of equipment (Skinner, et al, 1973, p 12). However, in the future, it appears desirable to select techniques based on their suitability to the type of structure, local environmental constraints, and cost. The applicability and operational characteristics of these techniques are discussed below.

#### Applicability of Techniques

Six mechanical wrecking techniques are selectively applicable to different types of structures. Applicability to specific types of structures is shown in Table 4. For instance, heavy equipment like a scoopdozer cannot be effectively used on structures made of reinforced concrete, structural steel and concrete, or plain structural steel. Another example, the gravity impact tools, including the "headache ball," are applicable to all structures except the structural steel facilities.

TABLE 4. MECHANICAL WRECKING TECHNIQUES AND THEIR APPLICABILITY

Demolition Technique	Type of Structure					
	Brick/ Masonry	Plain Concrete and Pavement	Reinforced Concrete	Structural Steel and Concrete	Structural Steel	Wood Frame
Heavy equipment methods	X <sup>(a)</sup>	X	NA <sup>(b)</sup>	NA	NA	X
Gravity impact methods	X	X	X	X	NA	X
Pneumatic/hydraulic impact methods	X	X	X	X	NA	NA
Hydraulic splitting	NA	X	X	X	NA	NA
Flame cutting						
Oxygen-acetylene	NA	NA	(c)	(c)	X	NA
Oxygen-lance	X	X	X	X	X	NA
Special techniques <sup>(d)</sup>						
Helicopter			X			NA
Double dozers			NA			X

(a) X denotes that the technique can be used for the above type of construction.  
 (b) NA denotes that the technique is not applicable.  
 (c) Used to cut steel after concrete is broken.  
 (d) Special situations demand such methods.  
 Source: Skinner, et al, 1973, p 23.

### Operational Characteristics

Mechanical wrecking techniques utilize diverse mechanical equipment such as scoopdozers, headache ball and crane, demolition hammers or rams, and hydraulic splitters. Each alternative has different operational characteristics as discussed below.

Heavy Equipment Methods. Heavy equipment, normally used in earth-moving operations, can be effectively used in demolition operations. Scoopdozers are generally used to push over one-story structures and demolish foundations and slabs. They are also employed at most demolition sites to concentrate debris for loading and haul-away. Front-end loaders are generally used to load concentrated debris in large haul-away dump trucks, which carry the wastes to a disposal site.

A typical demolition scoopdozer developed by the Ogden Company is shown in Figure 5. Scoopdozers are generally crawler-mounted and equipped with hydraulic or mechanical bucket dozers. The demolition dozers usually have a bucket at the end to provide a better grip on the structure being demolished. Recently, some demolition contractors have developed an arrangement to attach grappling booms (steel pipe up to 30-feet long and 5-inch diameter) to the bucket. This arrangement (see Figure 6) permits the use of scoopdozers or excavators to demolish structures 2 or 2.5 stories high.

Scoopdozers, commonly employed in demolishing single-story, split-level, or double-story residential structures, are time- and cost-efficient. They possess substantial flexibility when employed for spot demolition in highly developed residential areas. Also, the labor requirement is quite low; a 2000-ft<sup>2</sup> single-family dwelling requires about 0.5 to 1.0 man-day for demolition by scoopdozer.

Gravity Impact Methods. The gravity impact method is commonly employed in demolishing high-rise buildings. The method utilizes a heavy pear-shaped iron ball, commonly termed "headache ball", attached to a cable hoisted by a crane. A schematic view of a typical gravity impact

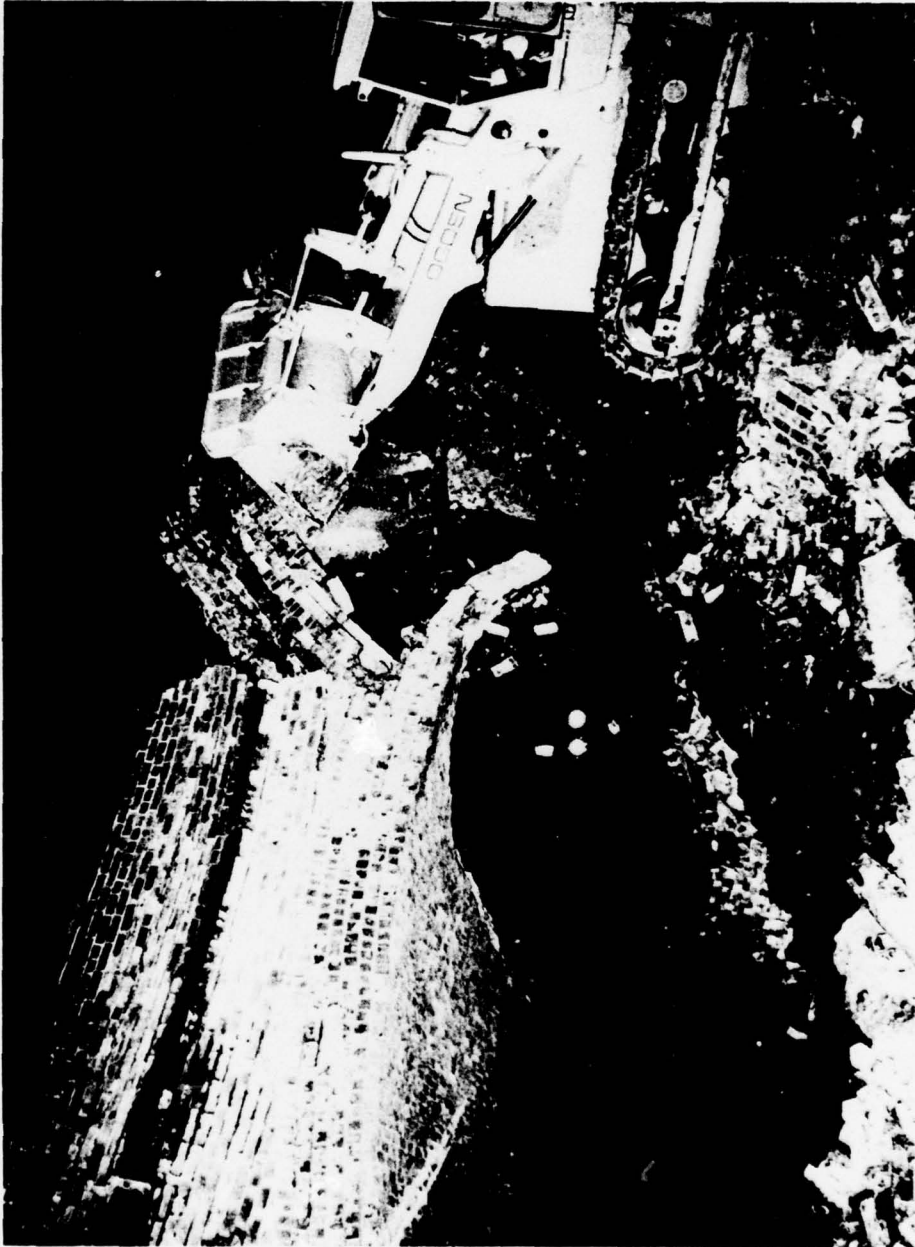

FIGURE 5. A TYPICAL DEMOLITION SCOOPDOZER

Source: Duane, H., Wrecking & Salvage Journal, Hingham, Massachusetts.  
Reprinted with permission.

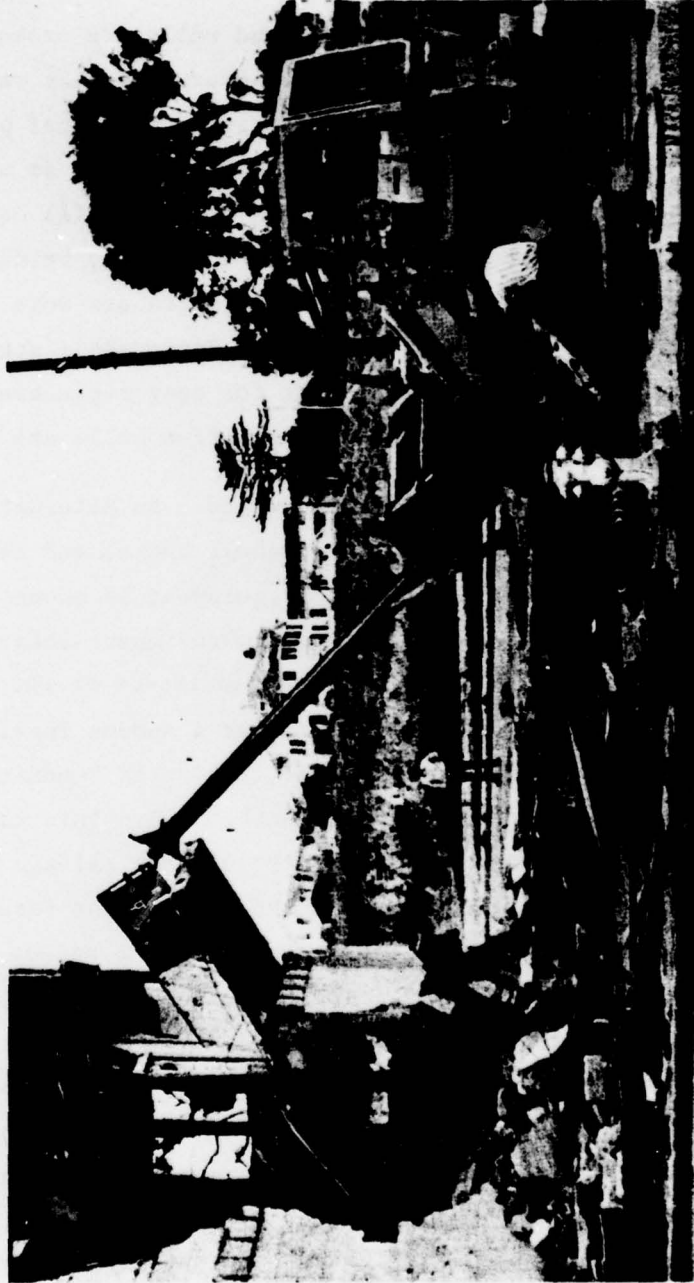

FIGURE 6. EXCAVATOR WITH 20-FOOT GRAPPLING BOOM USED TO PULL DOWN ARCADE BUILDING  
Source: Duane, H., Wrecking & Salvage Journal, Hingham, Massachusetts.  
Reprinted with permission.

equipment is shown in Figure 7. To generate impact, the headache ball is either swung at the structure or dropped on it. Slabs are broken up by dropping the ball; structural columns and walls are broken up by horizontal swings. Steel bars used in reinforcement of structures usually cannot be removed by gravity impact methods. This is a major operational problem usually resolved by utilizing a flame-cutting technique such as oxygen lance.

Demolition balls are of two major types: (1) cast iron balls and (2) steel or semisteel balls. Cast-iron balls, being of inferior quality, have a shorter life span. Steel balls are more desirable because of their longer useful life. The replaceable steel pins on these balls provide an effective arrangement for easy replacement of the balls. Some recent cost data for semisteel demolition balls are shown in Table 5.

Clamshell Bucket and Crane Method. An alternative to the headache ball and crane method is the clamshell bucket and crane. Typical clamshell bucket and crane demolition equipment is shown in Figure 8. The clamshell bucket is a device useful when impact shearing does a more effective demolition job, vis-a-vis simple impact of the ball. Impact shearing is a tearing action which follows a sudden impact. Also, when separation of salvageable materials is considered beneficial, clamshell buckets are employed in lieu of a headache ball. This technique, therefore, is more advantageous from the standpoint of both salvage and reclamation. As such, it is expected to be emphasized more in the future.

However, it must be remembered that the bucket does not provide as much impact energy as the ball. The ball, therefore, will be preferred when heavy or massive masonry structures are to be demolished. Even for these structures, a combination of the ball and the bucket devices may be used for effective demolition and waste separation. The demolition bucket is usually specially designed. As shown in Figure 8(c), the demolition buckets have gusset plates, corner bar braces, heavy lips, rider plates on scoop edges (to strengthen the edges), stiffeners to maintain lip alignment, ribs under corner brackets for added strengths, and longer teeth for better penetration and gripping action. These additional strengths are important to insure useful life (from the standpoint of equipment maintenance) of demolition buckets when compared to headache balls.

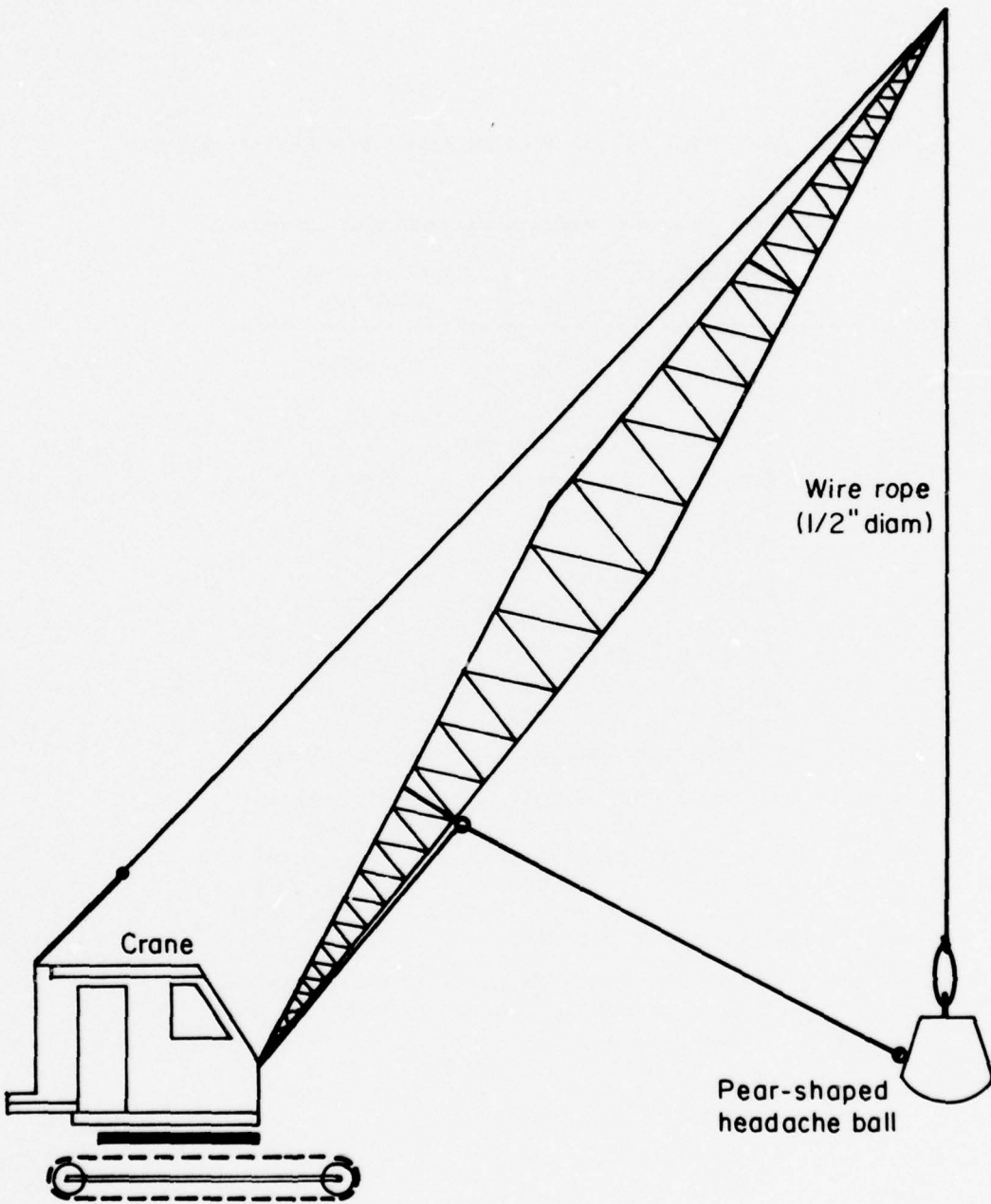

FIGURE 7. SCHEMATIC OF A TYPICAL GRAVITY IMPACT EQUIPMENT

TABLE 5. COST DATA (1975) ON SEMISTEEL DEMOLITION BALLS

Ball Weight, pounds	Capital Cost, <sup>(a)</sup> dollars
2,000	890
2,500	1,090
3,000	1,290
4,000	1,690
6,000	2,290
8,000	3,480
10,000	5,250

(a) The above capital cost does not include the cost of wire rope, snatch blocks, chain hoists, electric hoists, 1/2-inch wire rope, 6 x 19 hemp center, 1800-foot or 3600-foot reels. This additional cost may be \$0.20 per foot.

Source: United Road Machinery Company, Box 4141, Memphis, Tennessee 38104, June, 1975.



(a)



(b)



(c)

FIGURE 8. TYPICAL CLAMSHELL BUCKET AND CRANE DEMOLITION EQUIPMENT IN ACTION

Source: Duane, H., Wrecking & Salvage Journal, Hingham, Massachusetts.  
Reprinted with permission.

Tagline Controls. The common ball and crane or clamshell bucket and crane devices present problems and drawbacks that include:

- Risk of damage from wildly swinging headache ball or clamshell bucket
- Risk associated with bucket handling by workers
- Inaccurate control of bucket or ball causing accidents
- Fast reverse swinging during wrecking operation may cause excessive wear of swing clutches
- Up and down booming causing excessive wear of boom-hoist
- Swinging of the crane to cast a clamshell bucket or ball
- Increased wearing of bucket due to inaccurate or improper spotting.

Most of these problems can be eliminated by using a tagline control or a "tag master", such as that developed by Morin Manufacturing Company, West Springfield, Massachusetts.

A tagline is, thus, a multiple-purpose accessory designed for power shovels and cranes. It is a cable drum and clutch mechanism which provides an efficient performance as

- A tagline winder
- A dipper trip
- A haul-in drum.

The tagline control can be constantly maintained at all bucket levels by a manual control installed in the cab. The tagline controls can be useful to clamshell buckets, grapple buckets, wrecking balls, and magnets; and can be applied to operations like casting, twisting, and scrubbing.

Figure 9 is a view of a tagline winder and a crane equipped with such a device. The steps involved in aiming and casting a wrecking bucket or ball by means of a tagline are shown in Figure 10.

Pneumatic/Hydraulic Impact Methods. Many types of demolition hammers utilize either pneumatic or hydraulic impact mechanisms. These devices are usually tractor-mounted for safe operation. Hand-operated hydraulic devices are not safe and are seldom employed; for manual wrecking, pneumatic drills and sledge hammers are employed.

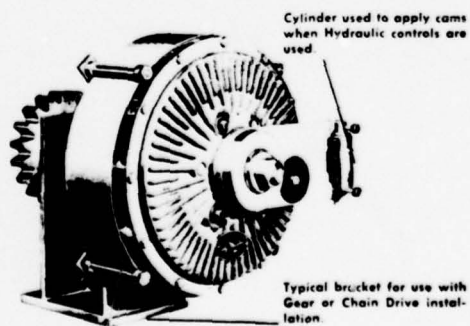
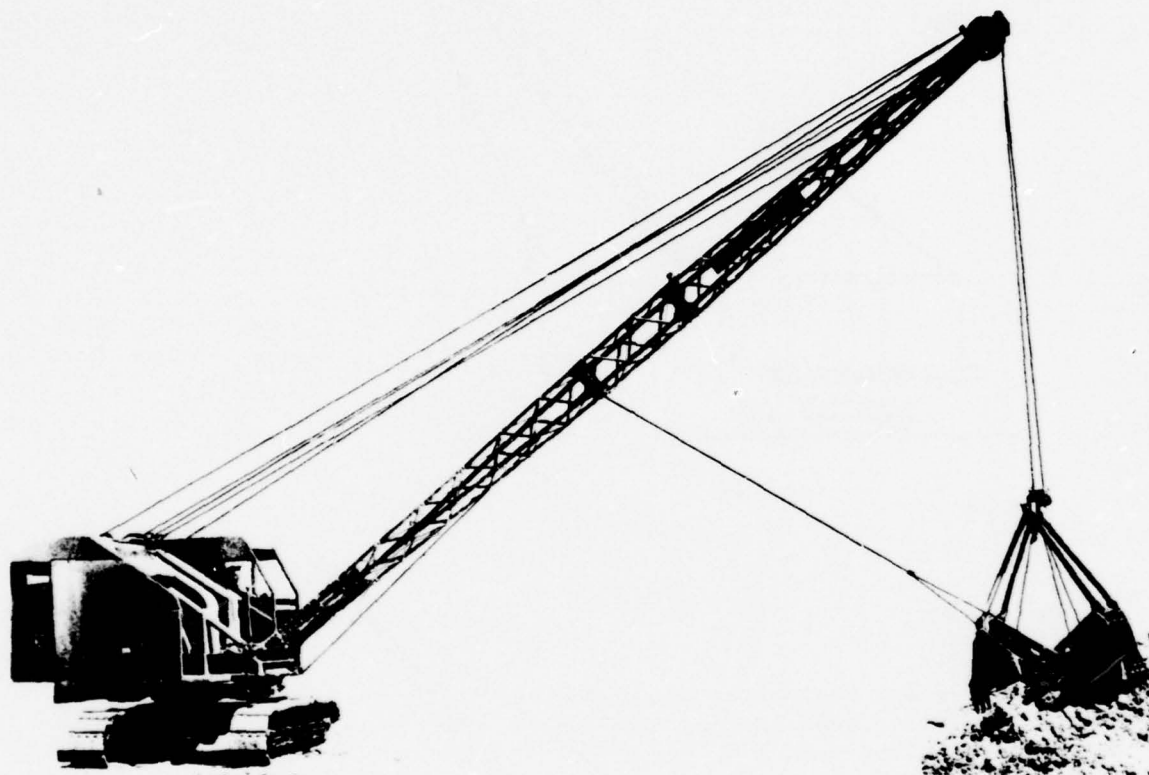

Cylinder used to apply cams when Hydraulic controls are used

Typical bracket for use with Gear or Chain Drive installation.

FIGURE 9. VIEW OF A TAGLINE (INSTALLED ON CRANE WITH A CLAMSHELL) AND THE DETAILS OF A TAGLINE CONTROL. Courtesy of Morin Manufacturing Company.

STEP 1

26

Operator swings boom so that it points toward target. Then, using Tag Master, he pulls bucket back toward boom in casting position.

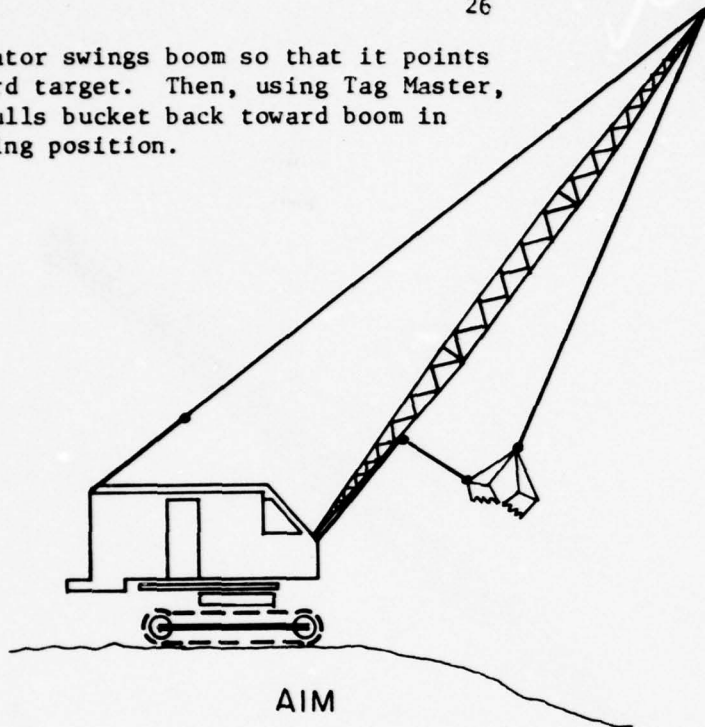

STEP 2

Operator releases Tag Master and bucket swings out like a pendulum past end of boom. As he drops bucket he snubs or twists it, with Tag Master Control to spot bucket exactly where he wants it.

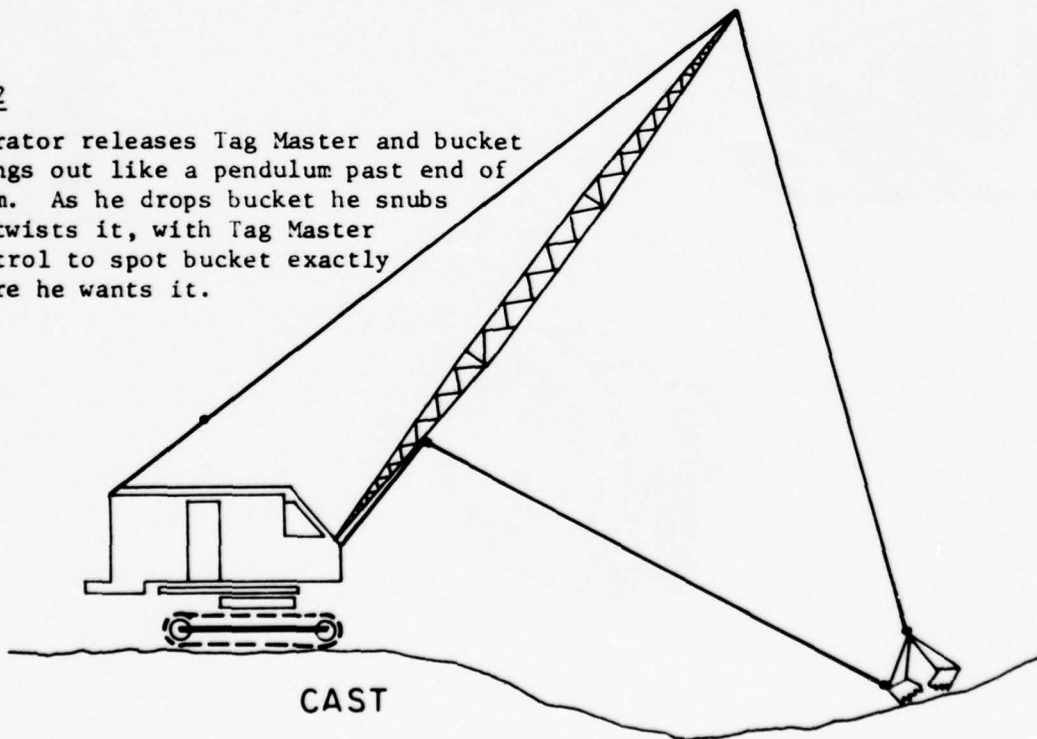

FIGURE 10. STEPS IN AIMING AND CASTING A WRECKING BUCKET OR A WRECKING BALL

The tractor-mounted hammers are popular and are used in various parts of the country. A typical crawler-mounted small-sized demolition hammer is used both in mechanical and manual demolition. These devices are called hob-knockers (shown in Figure 11) which can be raised by a crane to the top of multistory structures. Also hob-knockers as well as tractor-mounted hydraulic hammers are used to break up concrete, asphalt, and masonry. The hydraulic hammers are generally driven by the tractor hydraulic system. The hammers are generally employed when explosive demolition is not permissible and other conventional mechanical demolition techniques are found ineffective.

A demolition hammer, recently developed by the Kent Air Tool Company, Kent, Ohio, can be mounted on small backhoes and delivers 300 foot-pounds of impact per minute. It weighs 485 pounds and operates optimally with a 185-cfm compressor. The hammer can be equipped with 2.5-inch-diameter working points of different shapes, such as moil point, chisel point, and blunt steel working point. Such a hammer is shown in Figure 12.

Hydraulic Splitters. Hydraulic splitting techniques are intended to crack materials like concrete where controlled breaking is desired. Such techniques, not generally utilized for large-scale demolition of concrete pavements, are useful for removal of a limited pavement area at a specific location or breaking a certain component of a concrete structure. The technique serves also as an excellent substitute for explosives which cannot be used for controlled breaking.

A hydraulic splitter is a steel wedge which, when placed in a predrilled hole and hydraulically activated, cracks the drilled material. The splitting wedge contains a plug and two feathers, as shown in Figure 13. The wedge is inserted into a predrilled hole with the plug in a retracted position. By turning a control lever, the plug is activated forward and the two feathers are forced sideways against the wall of the hole. A break usually occurs in a concrete hole within 10 seconds, although in extremely hard materials, it may take as much as 60 seconds.

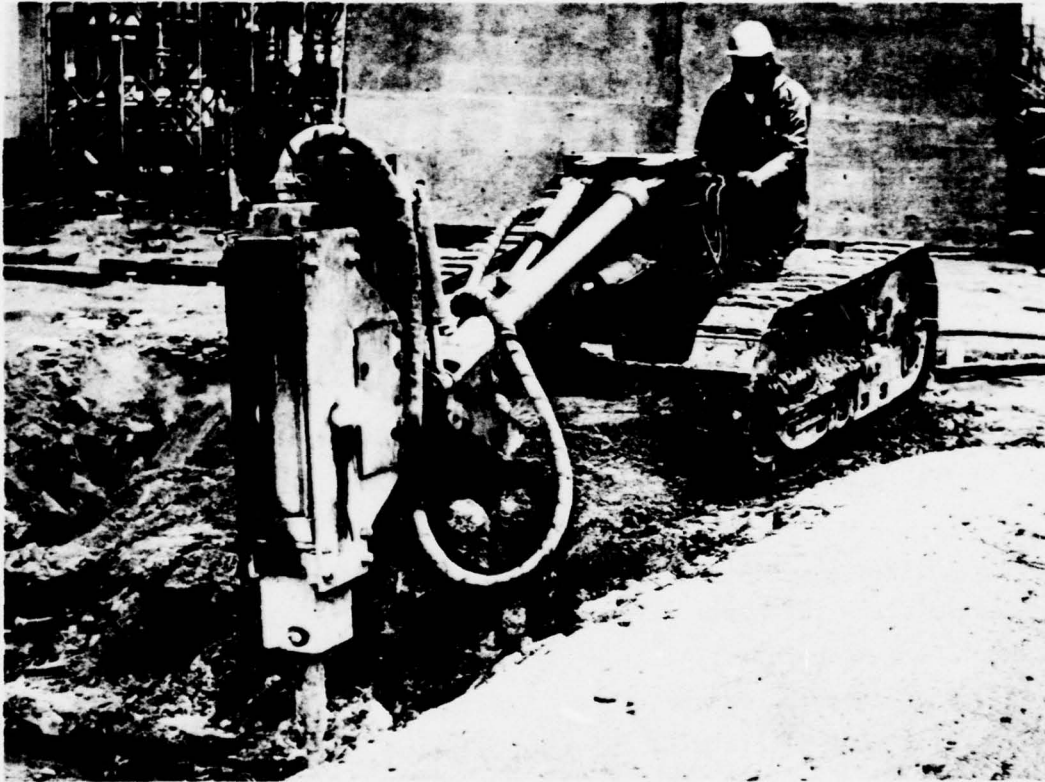

FIGURE 11. A TYPICAL HOB-KNOCKER IN OPERATION  
(note that the hob-knocker is mounted on a  
crawler and the operator is standing behind)

Courtesy: G.C. O'Brien Inc., Long Island, New York.

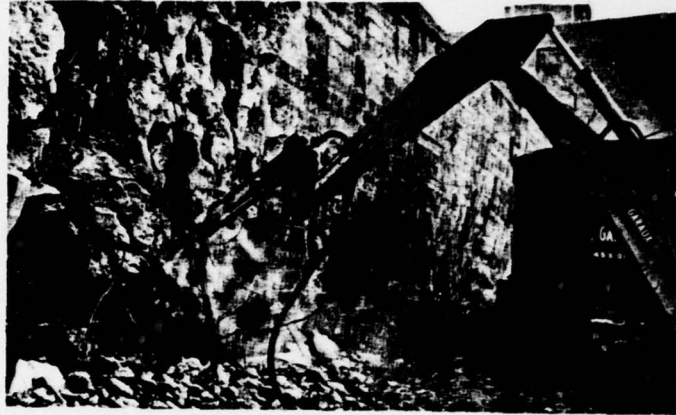
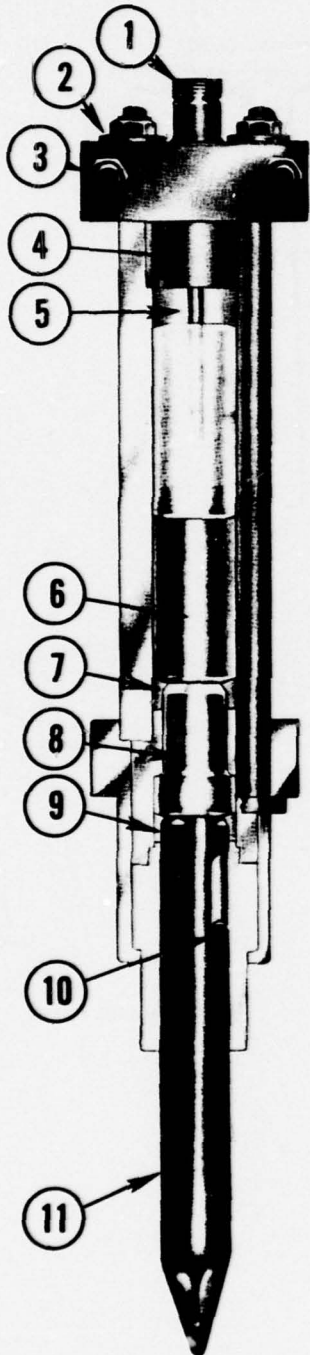

FIGURE 12-a. HAMMER IN OPERATION

Source: Kent Air Tools Co., Kent, Ohio.

LEGEND (FIGURE 12-b)

- |  |   |
|--|---|
| <p><b>1</b> Air Hose Connection — positioned to prevent hose damage, breaking, kinking and tangling.</p> <p><b>2</b> Spring Washers — absorb shocks and minimize stress to side rods.</p> <p><b>3</b> Mounting Bolts—boom mounting plates attach to the Ram with sturdy bolts instead of easily worn dowel pins.</p> <p><b>4</b> Automatic Double Kick-Thrown Valve — gives maximum power with minimum air consumption.</p> <p><b>5</b> 1st Air Cushion—keeps piston from hitting automatic valve.</p> <p><b>6</b> Piston — hits tappet, not breaker point; this means the inexpensive tappet wears, not the expensive piston.</p> | <p><b>7</b> 2nd Air Cushion—keeps piston from hitting the tappet seat.</p> <p><b>8</b> Tappet — heat treated, as are all Air Ram parts, to precision standards.</p> <p><b>9</b> 3rd Air Cushion—when breaker point breaks through, the tappet traps the exhaust air and cushions tappet action on tool check.</p> <p><b>10</b> Retainer Pin—heavy duty pin permits 60-second tool change.</p> <p><b>11</b> Breaker Point — standardmoil point is interchangeable with blunt, chisel or frost points; accepts tamper foot accessory.</p> |
|--|---|

FIGURE 12. TYPICAL AIR-DEMOLITION HAMMER

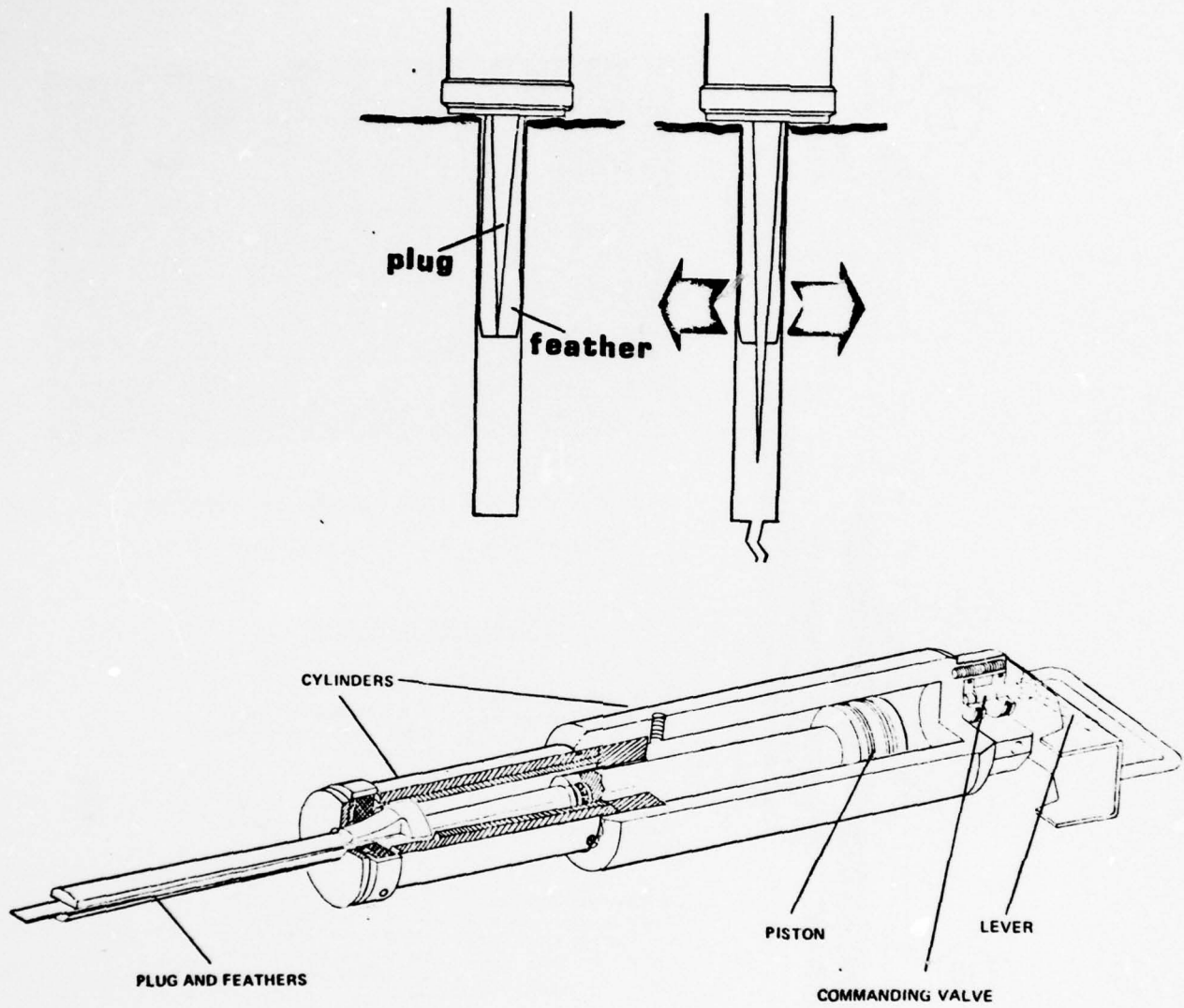

FIGURE 13. A SCHEMATIC OF THE DARDA SPLITTER

Source: EMACO, Inc., Elmwood Park, New Jersey.

The splitting force exerted by a DARDA\* splitter usually ranges between 176 to 410 tons, and maximum expansion is between 8.5 to 17 mm.

The hydraulic splitter is connected to a power unit with a pair of high- and low-pressure hydraulic hoses. Flow distribution bars can be employed to use up to five splitters from one power unit. The splitters must always operate simultaneously.

The power unit can be of three major types: (1) air, (2) gasoline, or (3) electric. The air power units or compressors can be used for drilling as well as cracking. If the compressor must be removed after drilling, gas units are used for splitting. If the power unit must be moved around frequently, gas power units are advantageous. The electric power units are desirable inside buildings and crusher installations. Splitters are relatively quiet units, require very little maintenance, and can be converted easily from one power unit to another.

Selected case studies by EMACO, Inc. have shown that

- Hydraulic splitting can be 11.6 times faster or cheaper than using paving breakers for removing a pavement
- Hydraulic splitters can demolish 2.22 times the material removed by tractor-mounted impact tools
- Cost of hydraulic splitting is about half as much as using a large compressor with a tractor-mounted impact tool.

Flame Cutting. Flame cutting is used to cut structural steel components and reinforcing bars in a demolition project. The rivet and bolt connections on steel structures may be flame cut. The reinforcing bars of broken-up concrete are also removed by gas cutting. The oxygen lance is a recent thermal technique that can be used for special situations where holes must be made in reinforced concrete and metals. The oxygen lance is valuable where very controlled demolition is required or where noise, attributable to other demolition techniques, may not be tolerated, for example, near hospitals. Two manufacturers of this type equipment are INTRA FIX, Inc., Wichita, Kansas, and the LCL Corporation, Atlanta, Georgia.

---

\* DARDA is the tradename of a hydraulic splitter developed by EMACO, Inc., 111 Van Riper Avenue, Elmwood Park, New Jersey. The above advantages of hydraulic splitting are limited only to special situations and generalization of these results may not be useful.

Recently, however, oxygen lance has increasingly become a substitute for gas cutting. The ease of application and the reasonable cost of oxygen lance account for its increasing popularity.

Water Jet Cutting. Water jet cutting is a new technique which employs the induced jet cavitation process to generate holes in concrete. Hydronautics, Inc., of Lowell, Maryland, has developed a small commercial water jet cutter called "Cavijet". A 1/8-inch diameter Cavijet can make a hole of about 0.15-inch depth at a jet pressure of 2000 psig and jet velocities ranging from  $10^4$  to  $10^8$  ft/sec. The relationship between hole depth and jet pressure is not linear. For example, a Cavijet cuts to a depth of 1.1 inch at 4000 psig whereas at 4700 psig it cuts a 2-inch deep hole.

A 1.4 horsepower Cavijet can cut approximately a 30 x 30 ft concrete slab with a 1/16-inch diameter jet at 1000 psig. The operating cost is estimated at 2 cents/sq ft of concrete. Since the equipment is still in the demonstration stage, investment costs are not available. Power requirements for the system appear to be lower than for mechanical cutters. Water jet cutters can provide more controlled cutting of concrete into various sizes and shapes for reuse on site or for hauling away to other reuse sites or for land disposal.

Special Techniques. In addition to the mechanical demolition methods discussed above, there are several special techniques for demolishing condemned structures. Two such techniques are discussed briefly:

- (1) Demolition by helicopter
- (2) Demolition by double dozer.

The use of helicopter and ball to bring down a structure is restricted to special situations. The technique is used when the required mechanical equipment cannot be taken to the demolition site, explosive demolition cannot be used on the job, and manual wrecking is inapplicable due to site/situation conditions.

The double-dozer technique is rarely used for demolition. It has been utilized at Fort Bragg, North Carolina, to destroy two-story wooden-frame barracks. As shown in Figure 14, the ends of a heavy cable

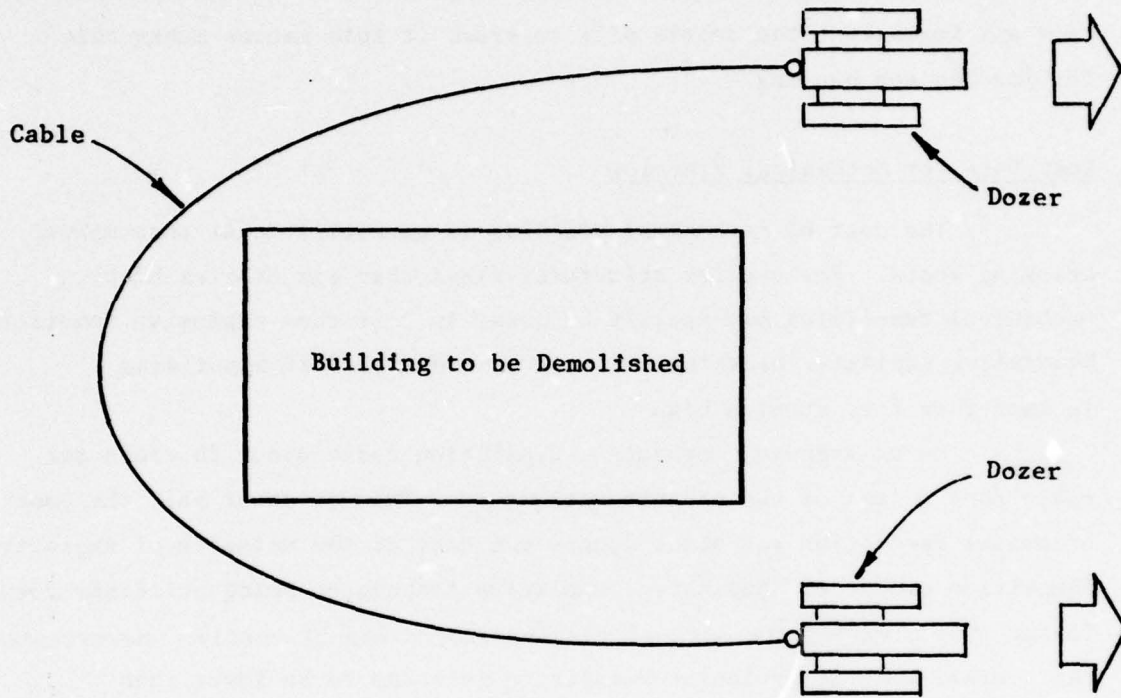

FIGURE 14. DRAG-THROUGH TECHNIQUE FOR DEMOLISHING FRAME STRUCTURES

were connected to the dozers, and the cable was then dragged through the frame structures causing the structure to collapse. Optimum demolition rate was achieved when the cable was run through the barracks about 2 feet above the floor level of the structure. The dozers were then operated back and forth over the debris pile to crush it into pieces manageable for loading and hauling.

#### Cost Data for Mechanical Wrecking

The cost of mechanical wrecking is generally lower than manual wrecking costs. For smaller structures (less than six stories high), mechanical demolition may usually be lower in cost than explosive demolition. Generally, explosive blasting will not be considered if a building is less than five stories high.

On an average, mechanical demolition costs about 10 cents per cubic foot volume of the standing structure. This is about half the cost of manual demolition and about double the cost of the majority of explosive demolition projects. Explosive demolition techniques bring buildings down faster, but clearing the site of tangled rebars can be costly. Nevertheless, the overall cost of explosive demolition is found to be lower than mechanical demolition.

A summary of cost data for 20 selected mechanical wrecking projects is shown in Table 6. The data show that the unit cost varies from 3 cents to 20 cents per cubic foot; most projects cost about 8 to 10 cents per cubic foot.

#### Environmental Impacts

The major environmental problems associated with mechanical demolition methods are

- (1) Noise
- (2) Dust
- (3) Ejecta or flying missiles.

Doubtless, the environmental impacts of mechanical wrecking are greater than that of manual wrecking. The impacts are discussed below.

TABLE 6. SUMMARY OF COST DATA FOR MECHANICAL WRECKING

Project Location and Date	Project Type	Floor Area, sq feet	Volume of Structure, cu feet	Cost of Demolition and Waste Disposal	Unit Cost	
					\$, per sq foot	Cents, per cu foot
(1) Boston (3/75)	Residential 12 parcels	39,000	390,000	\$37,773	0.97	10.0
(2) Boston (3/75)	Residential 10 structures	105,000	1,053,000	54,540	0.52	5.0
(3) Boston (4/75)	Residential 7 structures	153,500	1,535,000	39,990	0.26	3.0
(4) Chicago (5/75)	Residential building	13,200	132,000	6,940	0.53	5.5
(5) Chicago (4/75)	Residential 2 family structure	2,200	33,000	2,450	1.11	7.5
(6) Chicago (3/75)	Residential 8 units	13,736	200,000	7,000	0.51	3.5
(7) Chicago (5/75)	Commercial 1 story	22,000	440,000	26,000	1.18	6.0
(8) Chicago (5/75)	School 2 story	66,000	660,000	39,570	0.60	6.0
(9) Columbus (1/75)	Residential	1,200	12,000	1,250	1.04	10.5
(10) Columbus (2/75)	Commercial 9 story	29,000	288,000	58,000	2.00	20.0

TABLE 6. (Continued)

Project Location and Date	Project Type	Floor Area, sq feet	Volume of Structure, cu feet	Cost of Demolition and Waste Disposal	Unit Cost	
					\$, per sq foot	Cents, per cu foot
(11) Columbus (5/75)	Residential 3 units	4,400	50,000	\$ 5,000	1.15	10.0
(12) Detroit (8/75)	Residential 2 story	3,600	39,600	1,950	0.54	5.0
(13) Detroit ( /75)	Residential 42 units	33,600	386,400	46,000	1.37	12.0
(14) Detroit (2/75)	Residential 38 units	30,400	334,000	35,300	1.16	10.6
(15) Detroit (4/75)	Residential 20 bids	2,000,000	20,000,000	--	1.30 (high) 0.80 (medium) 0.50 (low)	13.0 (high) 8.0 (medium) 5.0 (low)
(16) New York City (2/75)	Residential 4 buildings	58,300	583,410	36,380	0.62	6.0
(17) New York City (3/75)	Residential 10 structures	24,300	243,860	11,979	0.49	5.0
(18) New York City (3/75)	Residential 7 structures	114,100	1,141,575	81,299	0.71	7.0
(19) New York City (5/75)	Residential	164,000	1,640,250	126,999	0.77	8.0
(20) New York City (6/75)	Commercial 7 buildings	57,500	575,275	51,000	0.89	9.0

Noise. The noise problem is usually caused by the heavy equipment employed in mechanical demolition. A correct understanding of the relative noise levels of various mechanical demolition options will be obtained through on-going research at the Construction Engineering Research Laboratory (CERL).

Dust. Emission of dust into ambient air is another significant problem of mechanical wrecking. In many cities, construction and demolition projects have significantly increased the level of particulate pollution in the downtown area. Generally, about 1 percent of the material demolished could become particulate emissions unless suitable measures to prevent dust formation during wrecking are instituted.

The presence of friable asbestos-containing materials (materials which contain more than 1 percent asbestos by weight and that can be crumbled by hand when dry) poses a serious human health hazard. Asbestos dust exposure can cause increased incidence of asbestosis and cancer both in the workers and in the population in the immediate vicinity of the demolition site. The formation of asbestos dust can be reduced by employing preventive measures specified in the NESHAP report (U.S. Environmental Protection Agency, 1974 and 40 CFR 61). The potential dust and asbestos control measures are discussed in Appendix A.

Ejecta. Mechanical wrecking equipment utilizes impact force to break up a structure being demolished. The impact force imparts kinetic energy to some of the material particles whereby the particles attain considerable velocity depending on the direction of the blow. These particles in motion at high velocities are called ejecta.

The ejecta problem associated with demolition by heavy equipment, gravity impact methods, and hydraulic impact methods can be serious. The problem can be controlled by installing plywood curtains and protected walkways around the structure. (The control measures are outlined in Appendix A.)

However, the ejecta problem due to mechanical wrecking techniques is not generally as serious as that due to the explosive demolition methods; thus, mechanical wrecking can be preferable to explosive demolition under certain situations.

### Safety Considerations

The safety problems of mechanical demolition are fewer than those of manual demolition. However, problems may arise under the following conditions (U.S. Department of Labor, 1967):

- When the ball, the bucket, or the scoopdozer hits the wrong target
- When the ejecta particles from the structure strike objects or people in close vicinity
- When a stray hunk of concrete or steel smashes into the front glass of the crane and injures the operator (Wittish, 1975)
- When a structure accidentally collapses, thereby burying the demolition crew under a pile of brick and steel (Wittish, 1975).

The first problem can be avoided by using a suitable tagline, whereas the other problems require suitable preventive measures.

The practice of riding a ball or a bucket is dangerous. It should be totally eliminated in the interest of safety.

### Demolition with Explosives

Employing chemical explosives for demolition requires highly specialized techniques (Skinner, et al, 1973). However, since the explosives can deliver large quantities of breaching charge, their use offers a very effective method of demolition. Chemical explosives are oxygen-bearing compounds or mixtures of chemicals which react violently when subjected to sudden shock and heat. The violent reaction produces a detonation, discharging a mixture of gases at high temperatures and intense pressure.

Chemical explosives can be classified into three major categories:

- (1) Primary high explosives
- (2) Secondary high explosives
- (3) Propellants.

The characteristics of these explosives are shown in Table 7. In actual practice, the primary high explosives are commonly used on nonmilitary demolition projects because their high detonation velocity causes

TABLE 7. CHARACTERISTICS OF EXPLOSIVE CATEGORIES

Properties	Primary High Explosives	Secondary High Explosives	Propellents
Sensitivity to heat or shock	Highly sensitive	Moderately sensitive; (a) and/or detonators (b) required boosters	Least sensitive; ignitor, flampark, or priming agent needed
Critical diameter or detonation threshold	Microscopic	Larger	Larger
Handling procedure	In small quantities and with caution	Some danger from flame, friction, heat, or shock	Handled as a flammable material
Storage	Separate from other explosives	Separate from primary explosives	Separate from primary and secondary explosives
Examples	PETN Nitroglycerin TNT	Black powder Ammonium nitrate Slurries	Black powder Nitrocellulose Dinitrotoluene
Detonation velocity	Greater than 5000 meters per second	Between 400 m/sec to 5000 m/sec	Less than 400 meters per second

(a) Detonators are heat sensitive primary explosives used to initiate the main charge.  
 (b) Boosters are sensitive secondary high explosives that reinforce the detonation wave and deliver a strong shock wave to the main explosive charge.

effective shattering of concrete and rocks. The principal applications and characteristics of major military and nonmilitary explosives used in the U.S. for demolition purposes are shown in Table 8.

#### Operating Characteristics of Major Explosives

The following four characteristics are important:

- Velocity of detonation
- Relative effectiveness as a breaching charge
- Intensity of poisonous fumes
- Water resistance.

Velocity of Detonation. The velocity of detonation is the speed at which the detonation wave travels through an explosive. The higher the detonation velocity of an explosive, the more shattering it can cause to the structure being demolished.

Relative Effectiveness as a Breaching Charge. The relative effectiveness as a breaching charge measures the degree of shattering action of an explosive relative to that of the TNT. The shattering action is determined by the detonation pressure or brisance, which is approximated by the following equation (Briggs, J., 1973):

$$P_D = 4.18 \times 10^{-7} \left( \frac{SgD^2}{1 + 0.8 Sg} \right)$$

where

$P_D$  = Detonation pressure, Kbar (1 Kbar = 14,504 lb/in<sup>2</sup>)

Sg = Specific gravity of the explosive

D = Detonation velocity, feet/second.

Commonly used demolition explosives produce a detonation pressure as high as 4 million psi.

TABLE 8. CHARACTERISTICS OF PRINCIPAL MILITARY AND NONMILITARY EXPLOSIVES USED IN THE U.S.

Name	Principal Applications	Velocity of Detonation meters/sec	Relative Effectiveness as a Breaching Charge (TNT = 1.00)	Intensity of Poisonous Fumes	Water Resistance
Ammonium nitrate	Quarry blasting, and filler in dynamites	2,700	--	Dangerous	None
PETN	Detonating cord, blasting caps, and linear-shaped demolition charge	8,300	1.66	Slight	Excellent
RDX (cyclonite)	Blasting caps, but rarely used for demolition	8,350	1.60	Dangerous	Excellent
TNT	Demolition charge used at times	6,900	1.00	Dangerous	Excellent
Tetryl	Booster charge (seldom used)	7,100	1.25	Dangerous	Excellent
Nitroglycerin	Demolition dynamite (commonly used)	7,700	1.50	Dangerous	Good
Amatol 80/20	Bursting charge (M)*	4,900	1.17	Dangerous	Very poor
Composition A3	Booster charge and bursting charge (M)	8,100	--	Dangerous	Good
Composition B	Bursting charge (M)	7,800	1.35	Dangerous	Excellent
Composition C3	Demolition charge (M)	7,625	1.34	Dangerous	Good
Composition C4	Demolition charge (M)	8,040	1.34	Slight	Excellent
Tetrytol 75/25	Demolition charge (M)	7,000	1.20	Dangerous	Excellent
Pentolite 50/50	Booster charge and bursting charge (M)	7,450	--	Dangerous	Excellent
Nitromethane	Filler explosive (M)	4,800	0.80	Dangerous	Fair
Slurry	Quarry work and blasting agent	5,000	0.70	Slight	Excellent

\* (M) indicates explosives that are commonly employed for military purposes only.

Source: Department of the Army, Army Manual No. FM 5-25, 1971, pp 1-2. (Modified based on more recent information from Winchester Blasting Services, Inc., Toledo, Ohio.)

Other Factors. The intensity of poisonous fumes and water resistance also determines the type and location of the structure on which an explosive is used. For example, dangerous explosives may not be used in areas close to human population; explosives with excellent water resistance may be utilized for underwater demolition.

#### Application of Explosive Demolition

Explosives can be used effectively in demolishing isolated structures. The structure must be separated at least by a 30-foot wide corridor from the neighboring structures. The 30-foot spacing is generally adequate to guard against safety problems.

In most demolition work, explosives must be used in a controlled mode so as to minimize collateral and environmental effects, cleanup operations, and inefficient use of explosives. The major techniques employed in explosive demolition relate to: (1) delay electric blasting caps, (2) shaped charges, (3) linear-shaped charges, and (4) controlled blasting. These are discussed below.

Delay Electric Blasting Caps. Delay electric blasting (DEB) caps are intended to detonate at a predetermined period of time after energy is applied to the ignition system (du Pont Company, 1969). The DEB caps permit the firing of complete rounds of several explosive charges in proper sequence from a single application of current.

DEB caps offer several advantages in the application of multi-story structures. These caps permit the use of several explosive charges in a well-synchronized and efficient manner to demolish a large, tall structure; this avoids the expensive and inaccurate process involved in the individual firing of several explosives with manual control delays. Also, the cost of the ignition system wiring network employed in the delay electric blasting cap method will be lower than in the manual control delay method. Three major types of DEB caps are available with a range of delay periods from a few milliseconds to greater than 12 seconds. The available types are: (1) instantaneous electric blasting caps, (2) millisecond delay series of caps (short interval caps), and (3) long interval delay series of caps.

An important aspect of explosive demolition is the arrangement of the DEB caps. The location and timing of the caps must be designed for optimum blasting results under all conditions. Much work on this aspect has been done by Controlled Demolition, Inc., Towson, Maryland; however, much of the information is unavailable for publication at this time.

Shaped Charges. Shaped charges may meet special needs in demolition work. They provide a fairly precise cutting tool that can be used to weaken or destroy key structural points. This is advantageous when the demolished materials must fall within a certain limited area. A schematic of the shaped charge is shown in Figure 15. Of late, however, shaped charges have been considered too noisy and linear-shaped charges are preferred for cutting steel.

Linear-Shaped Charges. There are many commercial names for linear-shaped charges. Basically, they employ the shaped-charge concept but use long, narrow charges with the cavity running the length of the charge as shown in Figure 16. These charges have proven excellent for steel cutting (Anonymous, 1972 and DeFrank, P., et al, 1966).

For steel cutting, use of a linear-shaped charge or charges usually results in the most efficient use of explosives. Usually, commercial suppliers provide data concerning their particular brand of linear-shaped charge. The data on penetration rate and optimum standoff help the user to estimate the correct charge sizes and placement in much the same manner as for conventional steel cutting charges (Department of the Army, 1973).

The size of most linear-shaped charges is small, usually 1 inch by 1 inch; as such, their placement geometry is quite flexible. This allows the linear-shaped charge to be used against virtually any irregular-shaped structural member. For steel structures, the linear-shaped charge is a valuable demolition tool.

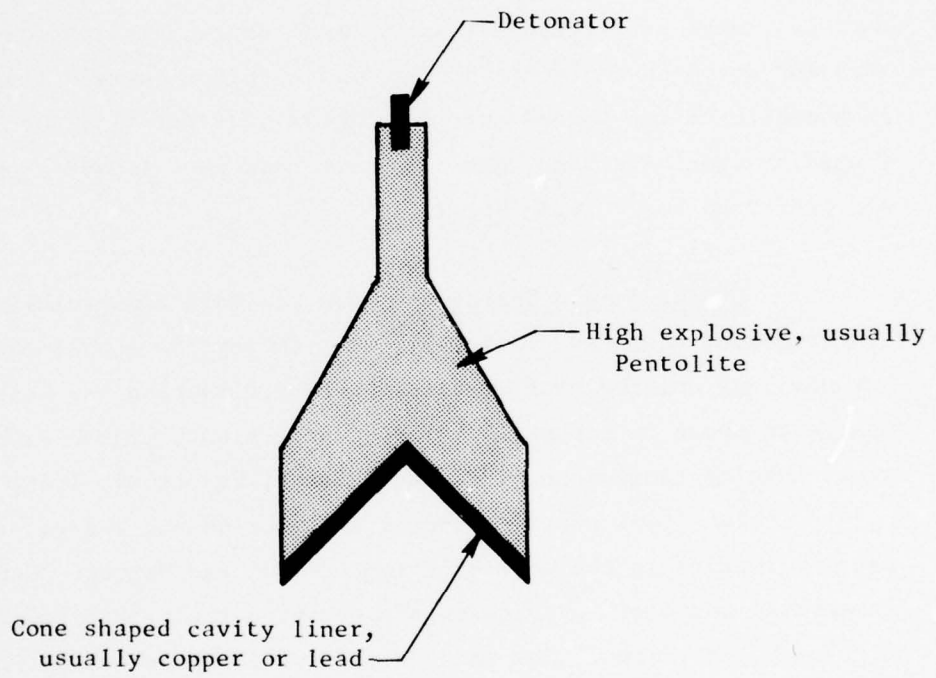

FIGURE 15. SCHEMATIC OF A SHAPED CHARGE

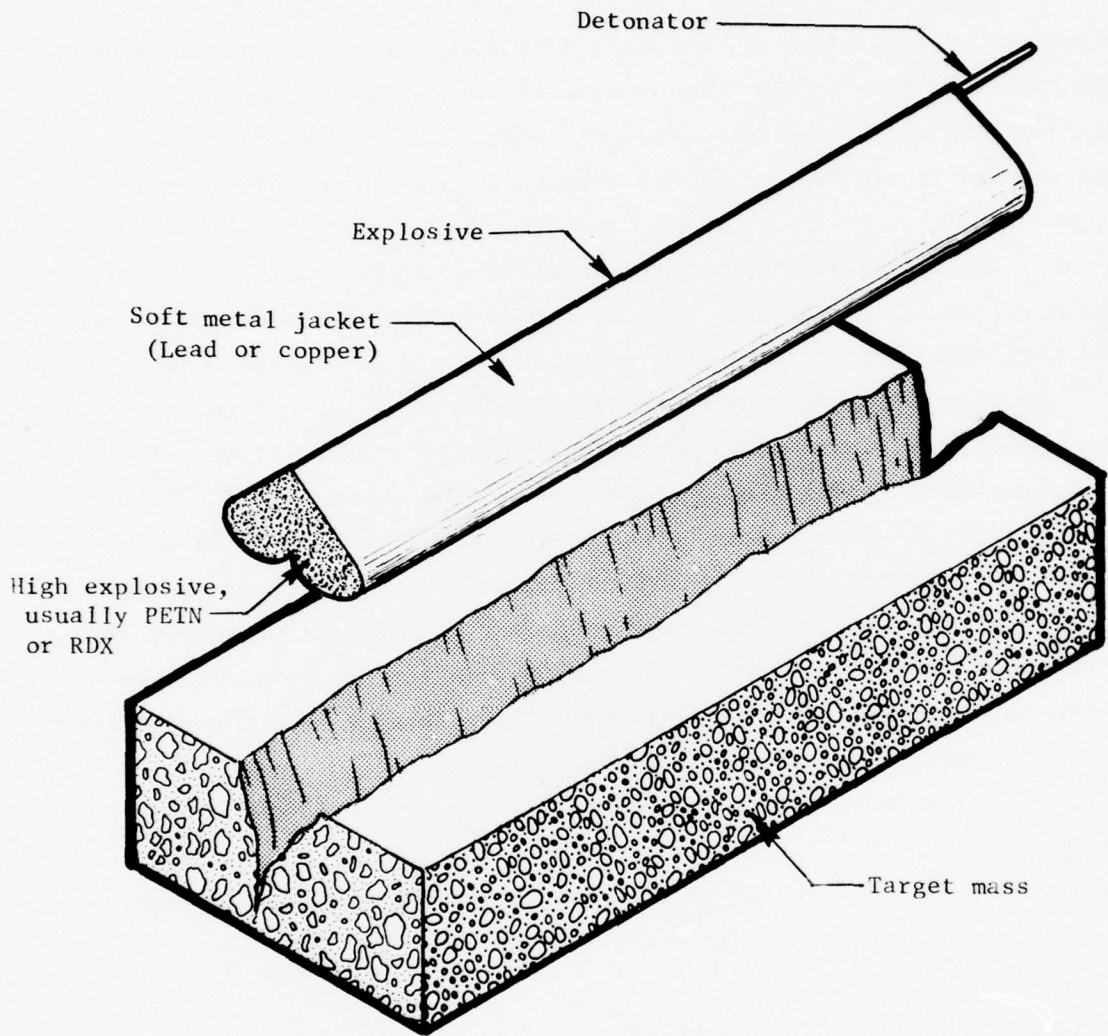

FIGURE 16. LINEAR-SHAPED CHARGE

Controlled Blasting. Controlled blasting involves the use of a combination of explosives and drilling techniques to economize on explosives usage by obtaining a better distribution of the explosive charges. Also maximizing the breakup of the structural members and minimizing of stressing and fracturing beyond the structure under consideration are achieved.

Controlled blasting systems are characterized by closely spaced patterns of small drill holes, with or without light explosive charges. Often their function is to produce a characteristically finished surface.

Controlled blasting systems fall into three categories, according to how and when explosives are used. One category uses drilling only, no blasting (line drilling). A second category is characterized by blasting after the main explosive round or rounds have been fired and the material excavated, to approach and create a finish surface (cushion blasting, trimming, smooth blasting). The third category involves blasting, and creating the finish surface, before the main rounds are fired (pre-splitting or preshearing). Which system to use depends upon the material and the equipment and time available.

Controlled blasting techniques are applicable to demolitions where some part of the structure is required for future work. It also is applicable for restricting damage when blasting in concrete or when trying to demolish walls or slabs along a specified outline.

#### Applicability of the Explosive-Based Demolition Techniques

Explosive-based demolition techniques can be applied advantageously to almost any tall structure. However, certain desirable controls or restrictions on the use of the technique for specific structures are as follows.

Wooden Structures. Explosives are generally not used on wooden structures. However, they may be used for shearing piles, post, or structural timbers. The amount of explosive required depends on the

diameter or the least dimension of the timber and how the charge is placed. Due to strength variations in various species of timber, it is advisable to conduct test shots to determine the best charge size.

Steel. Explosives are effectively used on steel structures and frames. The preparation of steel cutting charges depends on many factors, such as explosive type, placement of charge, thickness of the structural member, and type of steel. Since charges are difficult to confine or tamp on steel structures, the charge is placed essentially in direct contact with the steel members.

Concrete. The concrete, masonry, or brick structures can generally be treated as a single type of construction material. Structures of these materials are quite often demolished by the use of explosives since they can quickly collapse with a few well-placed high-explosive charges. However, the demolition of a multistory reinforced-concrete structure requires substantial analysis and planning to ensure the efficient use of explosives and to meet high safety standards. The presence of adjacent buildings or structures often requires control of blast effects. The impact of the total blast can be greatly reduced by employing time delays that detonate only a certain weight of explosives at one time (Carpenter and Cragg, 1973). When considerable restrictions are encountered, charges may be set off one at a time.

Rock and Earth. Occasionally, it may be necessary to remove earth or rock materials in demolishing structures. Earth is generally easier to move mechanically. Rocks can be blasted by explosives. The techniques for rock blasting have been discussed in detail by Briggs. The relationship between charge weight and a rock crater dimension is shown in Figure 17.

#### Cost Data on Explosive-Based Demolition

Cost data on explosive demolition projects are quite limited. Only three projects utilizing explosive demolition techniques were studied.

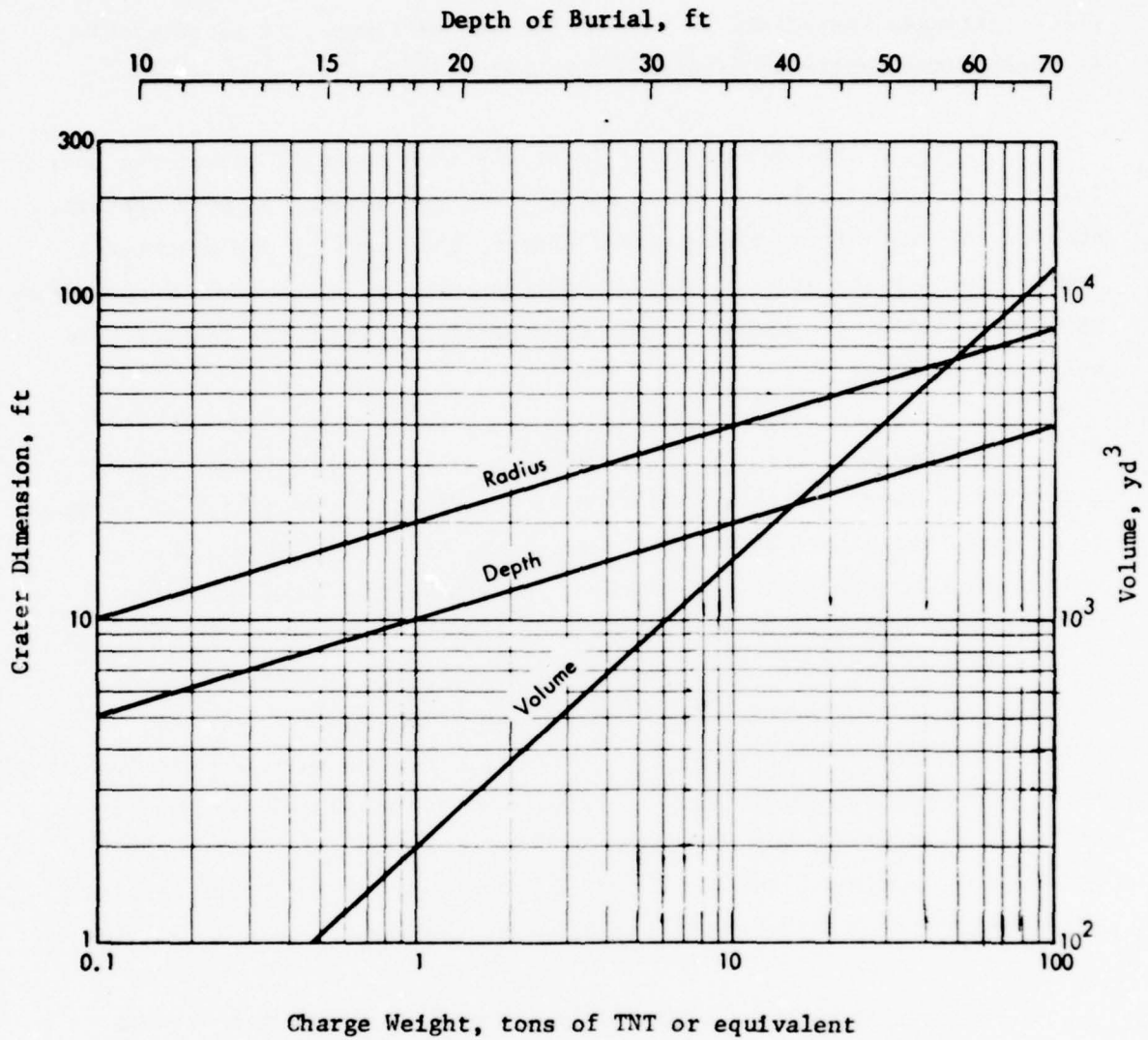

FIGURE 17. CRATER DIMENSION AND REQUIRED EXPLOSIVE CHARGE-WEIGHT RELATIONSHIP FOR DRY ROCK

Source: Briggs, 1973, p 87.

The data show that explosive demolition costs range from 3 to 5 cents per cubic foot volume of the structure. The cost includes capital and operating costs of demolition equipment and off-site disposal of wastes.

Usually, the cost of explosive demolition is lower than the cost of mechanical demolition. The cost of mechanical demolition varies considerably, ranging between 5 to 10 cents per cubic foot. For structures about six stories high, the explosive demolition cost is usually half the cost of mechanical demolition.

#### Environmental Impacts

Explosive-based demolition projects can cause various environmental problems. These problems relate to:

- (1) Explosion products (poisonous gases)
- (2) Air blast
- (3) Ground motion
- (4) Ejecta or flying missiles
- (5) Noise
- (6) Dust.

Explosion Products. Explosion products generally consist of water vapor, carbon dioxide, carbon monoxide, nitrogen, and oxides of nitrogen. Carbon monoxide and oxides of nitrogen are poisonous fumes that may be hazardous to the wrecking crews working in areas of poor ventilation. Explosives are generally rated in terms of fume ratings or intensity of poisonous fumes. Proper ventilation of the work area is required before the demolition personnel may reenter the area after explosive demolition. The quantities of poisonous fumes generated are insufficient to cause widespread danger to the general public and are dangerous only to workers in confined spaces.

Air Blast. The explosion usually generates a blast wave which is propagated through air or other medium away from the explosion.

The blast wave causes a pressure-time distribution as shown in Figure 18. The duration of blast waves is usually too short to cause a nuisance. The overpressure under these circumstances ranges from 0.1 psi to 2.0 psi.

Blast waves generated by an explosion under water can affect marine life. As a rule of thumb, fish will survive underwater explosions when they are a distance of  $50W^{1/3}$  feet, where W is the charge weight in pounds.

Ground Motion. An explosion above, on, or beneath the earth's surface produces ground motion. The magnitude of the ground motion increases as the charge detonated is closer to the earth's surface and is at a maximum when the charge is detonated subsurface at a depth of  $0.5W^{1/3}$  feet, where W is the weight of the charge in pounds.

The amplitude, duration, and characteristics of the ground motion can vary over a wide spectrum depending upon many factors, the most important of which include the amount of energy released by the explosion, the distance from the source, and the local soil characteristics. The motion of structures is quite complex, and further complications are introduced by the type of material(s) used for the building foundation and the overall effect of how the ground motion propagates. Loss of shear strength in cohesive and granular soils can be induced by ground motion and causes phenomena such as liquefaction and shear deformation to occur. Loss of shear strength can cause settlement of foundations, localized slope stability problems, or even gross slope failure.

Safe working levels for ground motion are difficult to quantify unless the characteristics of the ground mass (in the vicinity of the explosion) are known. Researchers have defined empirically safe working levels of ground motion for residential structures. Damage to other types of structures could correlate with displacement, acceleration, or energy in the seismic wave.

Regulatory standards have been set by several states and Federal agencies for control of seismic vibrations from explosive detonations. A measured parameter commonly used for correlating structure damage from

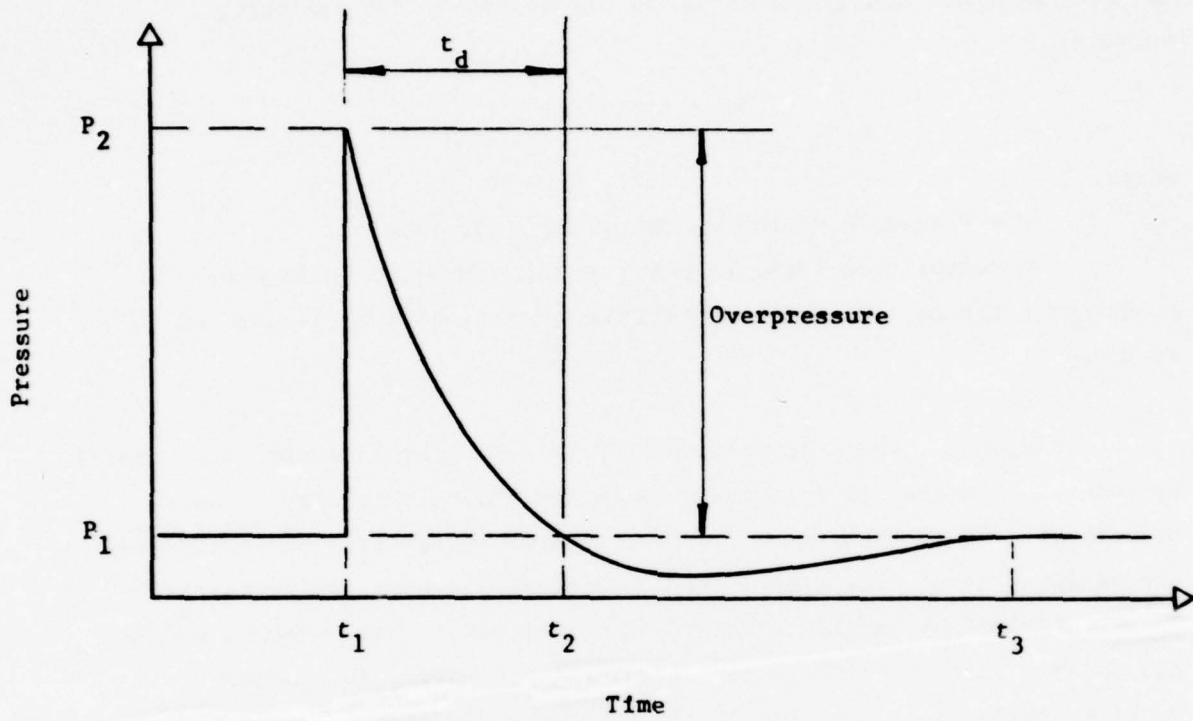

FIGURE 18. TYPICAL PRESSURE-TIME CURVE FOR AN EXPLOSION BLAST WAVE IN AIR

Source: Skinner, et al, (1973), p 46.

vibration is energy ratio (E.R.). Prior to the adoption of peak particle velocity, an energy ratio limit of 1.0 was a common restriction for many states. Energy ratio can be calculated by the following formula:

$$E.R. = (3.29 FA)^2,$$

where

F = Frequency of the vibration in cycles/second

A = Amplitude (displacement) of the vibration in inches.

An energy ratio of 1.0 equals a particle velocity of 1.92 inches per second.

Ejecta. The kinetic energy of an explosion is imparted to nearby objects or to masses of soil surrounding the explosive charge. These objects or masses, which have received kinetic energy from the explosion, are called ejecta. The ejecta from an explosion create pollution and safety problems by causing a hazard to structures, other objects, people, and animals in the vicinity. The importance of ejecta as a safety problem increases as the size of the explosive charge increases.

The measures required to abate ejecta problems are discussed in Appendix A.

Noise. Noise is an undesirable by-product of blasting. It is a nuisance factor, which has both health-related and psychological implications. Sudden "bangs" associated with an explosion are quite irritating, whereas semisustained high-level sound can actually be physically damaging. The fright (sudden fear and alarm) resulting from a sudden explosion noise adds to its undesirability. Suitable methods are currently being developed to measure, predict, and abate noise problems generated by various explosives used for demolition.

Dust. Normally, a large amount of dust is created when a structure is demolished with explosives. Generally, the dust cloud exists for a short time, while conventional demolition of the same structure may cause a dust problem over a much longer period of time. No quantitative studies have been conducted to compare the amount of particulate matter released to the atmosphere by explosive demolition and conventional demolition. The amount of dust created by waste removal operations is basically the same for both types of demolition.

One recommendation for minimizing the dust hazard is to detonate the explosives when it is raining and/or when the wind speed is low. This would help to confine the dust to the demolition area and lessen the impact on the surrounding environment.

#### Safety Considerations

The safety considerations in explosive demolition meet more serious problems than those in mechanical demolition. Possible problems are

- Damage to nearby and adjacent structures
- Shock damage to individuals exposed to the seismic zone of the explosion.

The first problem can be greatly alleviated by distributing and timing the shots such that the structure collapses inward. Also, the spread of the waste pile beyond the property line can be made minimal. Such practices have been well demonstrated recently at Fort Wayne, Indiana, by Controlled Demolition, Inc., of Towson, Maryland, and the Wrecking Corporation of America of Washington, D.C. The conditions at and after detonation at the Fort Wayne 12-story Keenan Hotel explosive demolition project are shown in Figure 19.

The shock damage to individuals may be avoided by conducting demolition during periods when very few persons (general public) are expected to be present in the vicinity of the project. Efforts should also be made to inform and/or remove any person in the vicinity of the project prior to the explosion.

The above measures may provide adequate safety for explosive demolition projects in the future.



After Detonation →



FIGURE 19. THE FORT WAYNE, INDIANA, KEENAN HOTEL EXPLOSIVE DEMOLITION PROJECT

Source: Controlled Demolition, Inc., Towson, Maryland.

### Underwater Demolition

The development status of underwater demolition technology is still embryonic; very little generalized information is available in existing literature. Three major references dealing with this technology are by: DeFrank, P., et al, 1966<sup>1</sup>; Dennis, J. A., 1962<sup>2</sup>; and Rahe, R. H. and Ransom, R. S., 1967.<sup>3</sup> For the study presently reported these references were not reviewed in detail. However, it appears that underwater demolition can be achieved by suitable explosives. A detailed analysis of the underwater demolition techniques is more appropriately the subject of a separate study, since the scope of the present study is limited to demolition of land-based structures.

The cost of underwater demolition of a concrete pile 60 feet high having a 1.5 foot diameter is estimated to range from \$80 to \$120, i.e., \$0.75 to \$1.13 per cubic foot of structure demolished.

### Conclusions

In this section the available technological options for conducting demolition were described. The major options are: (1) manual wrecking, (2) mechanical wrecking, (3) explosive demolition, and (4) underwater demolition. Mechanical demolition is the option most frequently employed by military and nonmilitary wreckers. Manual wrecking is generally employed where site access restrictions are severe or stringent regulations require its usage. Explosive demolition may be considered for structures greater than six-stories high and suitably located relative to other structures. Underwater demolition is a specialized technique suited for underwater work.

<sup>1</sup> DeFrank, P., et al, "Explosive Technology--A New Tool in Offshore Operations," Paper No. SPE 1602, American Institute of Mechanical Engineers--Society of Petroleum Engineers, 1966.

<sup>2</sup> Dennis, J.A., "Steel Cutting With High Explosive Charges," Army Engineer Research and Development Labs, December 1965, p 172.

<sup>3</sup> Rahe, R. H. and R. S. Ransom, "Stressful Underwater Demolition Training--Serum Urate and Cholesterol Variability," Navy Medical Neuropsychiatric Research Unit, San Diego, California (1967) p 6.

### 3. ENVIRONMENTAL CONSIDERATIONS IN WASTE DISPOSAL

The disposal of demolition wastes is a growing environmental problem in this country. A decade ago, demolition wastes were first open-burned on-site to eliminate all combustible matter (wood, paper products, and plastics). The open-burning process reduced the volume of disposable wastes by 60 percent. Also, the incineration process eliminated significantly the leachate-forming potential of the residual solid wastes which were ultimately sent to an open dump or sanitary landfill. Such methods of disposal of demolition wastes are no longer possible today; the future disposal of demolition wastes is a more complex problem.

#### Open Burning

Presently, the open burning of solid wastes is prohibited by law in most states. Even in permissible areas, open burning is generally considered environmentally undesirable and improper. Thus, open burning of solid wastes should be considered an unacceptable process.

#### Controlled Burning

Controlled burning of wastes is still permitted in many municipal jurisdictions. One type of controlled burning device currently utilized by some demolition contractors is the Air Curtain Destructor (ACD) developed by the DriAll, Inc., Attica, Indiana. The device (see detailed description in Appendix A) has been approved temporarily in most jurisdictions and has received long-term approval in Alabama, California (with the exception of Los Angeles), Illinois, Indiana, Ohio, Oregon, Virginia, Wisconsin, and a few other states. The Wisconsin regulations require that the pit be designed to insure stability of the pit walls.

The ACD controlled-burning device has been used extensively by the Cleveland Wrecking Company and the railroads to incinerate demolition wastes. Usually, this device can operate with a dust emission equivalent of less than 0.5 Ringelmann over 95 percent of the period of operation.

The U.S. Environmental Protection Agency tests indicate the following emissions during ACD operation (letter from J. Downs, DriAll, Inc., April 16, 1975).

<u>Pollutants Emitted</u>	<u>Results of Measurements</u>
Particulates	Too low to measure
Sulfur dioxide	Too low (-0)
Carbon dioxide	0.075 ppm
Nitrogen dioxide	Too low (-0)

Although the ACD is capable of low emissions, its proper operation is of prime importance in insuring the low emissions. It is not unusual to find that many improper operations of ACD have resulted in high pollutant emissions.

#### Open Dumping

Open dumping of demolition wastes was a common practice a decade ago when the use of demolition wastes to fill swamps, marshes, and other voids and pits was very prevalent. Recently, such practice is being strongly discouraged since filling of marshes, swamps, and ponds can cause irreparable environmental and ecological damage. For instance, certain marshes are spawning grounds for fish and other ecological entities. Other swamps and marshes serve as protective buffers for freshwater bodies, since they can filter out polluted discharges. Dumping wastes in marshes can increase water pollution substantially. The substantial amounts of wood, paper products, and plastics present in the demolition wastes create a serious leaching potential when open-dumped near freshwater bodies. Due to the ban on open burning and the difficulty of obtaining controlled-burning permits, the demolition wastes sent to the dumps now contain higher amounts of leachable matter.

In most cities, the open dumps are located at long hauling distances from demolition sites. Usually, the distance ranges from 10 to 40 miles. Transportation of wastes over long distances results in waste of fuel energy, requires transportation-related services, and consequently increases project costs.

### Sanitary Landfill

Due to their polluting potential, demolition wastes should be disposed of in a sanitary landfill. Visual inspection of several construction and demolition dumps at Army posts indicated that wastes disposed of at these dump sites contain a high proportion of wood and masonry which may produce undesirable leachates. Therefore, it is reasonable to recommend that demolition wastes should be disposed of in sanitary landfills. However, salvage or reclamation of wastes at a recycling plant is a preferred route to disposal. Disposal in sanitary landfills should be a temporary measure only and should be used until a planned effort to encourage salvage and reclamation can be initiated. This aspect is discussed in the next section.

### Salvage and Reclamation

Demolition projects generally produce large volumes of solid wastes. Most of these wastes are disposed of unproductively to remote landfills at this time. This situation can be altered if a large proportion of the waste can be salvaged and/or reclaimed at a recycling plant.

Salvaging involves saving or obtaining secondary materials from a waste stream by hand picking, sorting, disassembly, or other related measures. On the other hand, reclamation or recycling involves utilization of secondary materials in an industrial process by which they are transformed into useful products. Effective utilization of demolition wastes in the future should involve an optimal combination of salvage and reclamation.

The demolition wastes generally contain the following secondary materials:

- (1) Bricks
- (2) Wood
- (3) Concrete
- (4) Paper products
- (5) Metals (e.g., copper, aluminum, steel)

- (6) Asphalt shingles
- (7) Soil or debris.

The relative percentage composition of the materials in the waste is a function of the type of structure and its age.

Some contractors have salvaged bricks and a few other materials. These contractors have found salvaging these materials to be quite profitable. On the other hand, certain materials cannot be salvaged profitably. These materials may be recovered by means of selected reclamation alternatives. Finally, it may be useful to modify the existing demolition technology to achieve greater separation of demolition wastes. This separation will greatly improve the reclamation of wastes. This section briefly describes the potential for the following resource-recovery operations:

- (1) Brick salvage
- (2) Salvage of other materials
- (3) Reclamation.

### Brick Salvage

Bricks are the most important waste component currently salvaged by many contractors. Bricks have been salvaged manually in almost all cases studied; these operations are reported as quite profitable, even in a small-scale operation. Information on cost and profit from seven brick salvage operations is shown in Table 9.

In one operation studied, bricks have been salvaged by a mechanical device recently developed by the Quan-Terra Corporation, Los Angeles, California. A schematic of this new device is shown in Figure 20 and a detailed description is presented in Appendix B. Although in the development and testing stage, the new equipment is anticipated to be economically profitable for large-scale brick salvage operations.

In the future, the Army could require the manual or mechanical salvage of waste bricks on major demolition projects by introducing an appropriate set of specifications and contractor performance evaluation criteria on an experimental basis. Since in most situations salvage of

TABLE 9. INFORMATION ON SALVAGE OF BRICKS

City	Type of Salvage	Cost of Salvage	Price of Salvaged Bricks	Percent Profit
Columbus, Ohio	Mechanical separation	Capital cost = \$14,000 Operating cost \$50 per 1000 bricks	\$80 per 1000	60
Chicago, Illinois		Bricks not salvaged at Chicago usually. Old bricks absorb water and crack. However, some recycling may occur as a result of incentives.		
Detroit, Michigan	Manual separation	\$50 per 1000 bricks	\$80 per 1000	60
Boston, Massachusetts		Limited or no salvage of bricks at this time. Salvage likely to increase if incentives are provided.		
New York, New York	Manual separation	\$45 per 1000 bricks	\$55 per 1000	22
Oklahoma City, Oklahoma	Manual separation	\$20 per 1000 bricks	\$65 per 1000	225
Los Angeles, California	Mechanical separation	\$50 per 1000 bricks	\$65 per 1000	30



FIGURE 20. MECHANICAL BRICK SALVAGING EQUIPMENT  
Source: Quan-Terra Corp., Los Angeles, California

bricks is expected to be quite profitable, demolition contractors who show reduced bids as a result of salvaging efforts may be sought out where possible.

#### Other Salvage

Besides bricks, a few other materials are salvaged by certain contractors. The salvage can be profitable for a few other materials such as:

- Decorative wooden doors and windows
- Large wooden beams
- Steel beams and joists
- Aluminum sidings
- Copper pipes
- Scrap steel furnaces
- Well-maintained chandeliers
- Air conditioners.

These materials are salvaged by selected demolition contractors, who maintain inventories of secondary materials obtained from their demolition sites. The salvaged products are either sold to construction contractors or to private individuals employing used materials for repair or new construction. The Army may require their demolition contractors to undertake such salvage operations on future wrecking projects.

Another group of demolition contractors requisition the services of a "liquidation firm". A liquidation firm usually undertakes to sell by auction all salvageable materials prior to the demolition of a structure. Army contracts for construction and demolition could employ such firms to ensure that all possible salvageable materials have been disposed of before and after any demolition operation. This is an effective salvaging approach, since the liquidation contractor is primarily interested in salvage rather than demolition and waste disposal by burial.

## Reclamation

Several waste components are unprofitable for salvage. These wastes are

- Broken bricks
- Remaining wood wastes
- Concrete
- Paper products
- Steel scraps
- Asphalt shingles
- Soil or debris.

Since salvaging is not practicable, reclamation alternatives for these wastes should be investigated. The reclamation of these wastes has been nonexistent, with the major hurdles being

- (1) The mixed nature of the waste
- (2) The lack of a demonstrated reclamation process.

It, therefore, is essential to direct future research to identify, test, and evaluate alternatives for

- (1) Waste separation
- (2) Waste reclamation.

Better methods are needed to separate wood, concrete, and broken bricks from the waste streams. The separation of these wastes may be achieved by two methods:

- (1) Modification of existing demolition technology to improve waste separation
- (2) Identification and testing of methods for separating mixed waste.

The first method, which has been considered quite promising by many contractors, is discussed in the next section. The second method is generally the first step of a reclamation process. (As such, it should be assessed as a component of a waste reclamation alternative. The testing of reclamation alternatives is discussed in a later section.) The practical feasibility of utilizing these approaches is yet to be fully demonstrated. Although they have been utilized by a few contractors in limited situations, their systematic development and demonstration is needed in order to help reduce wasteful squandering of useful materials.

### Modification of Existing Demolition Techniques

This study and assessment of existing mechanical demolition techniques indicate that effective separation of wastes can be achieved by

- (1) Designing better equipment
- (2) Developing better demolition procedures.

The design of better equipment involves the development and testing of grab buckets that are capable of separating wood, bricks, metals, etc. Specially designed clamshell buckets can also be used with a suitable boom. Grab buckets can also be equipped with cutting edges that can separate different waste materials from a given structure.

The development of better demolition procedures involves certain procedures for separating waste components at a demolition site. The separated wastes can then be loaded on partitioned dumpers for transportation to a reclamation plant.

It is anticipated that these new designs and procedures will allow improved separation of wood, paper products, concrete, and bricks. There is a need to undertake additional experimentation to establish and test these new designs and operating procedures.

### Testing of Selected Reclamation Alternatives

Many reclamation alternatives for utilizing demolition solid wastes exist.<sup>4</sup> Some of the potential alternatives are

- (1) Incinerating wood waste
- (2) Converting wood to fuel oil
- (3) Recycling concrete
- (4) Making bricks from wastes
- (5) Making concrete blocks from waste concrete and glass
- (6) Constructing pavement from waste concrete
- (7) Making "thixite" panels
- (8) Making mulch from brush
- (9) Recycling steel scraps.

<sup>4</sup> "Predictive Criteria for Construction/Demolition Solid Waste Management," Technical Report N-14, CERL, November 1976.

The above alternatives currently remain unutilized. Development of new guidelines by the U.S. Army could encourage the application of alternatives selected from the above list. For example, the separated wood and paper products may be utilized in existing coal-fired boilers to generate required heat energy. New guidelines are needed to encourage the use and testing of these reclamation approaches.

The separated and cleaned concrete wastes and broken bricks may be utilized for pavement construction and construction and strengthening of foundations. Preliminary testing by the U.S. Army Waterways Experiment Station at Vicksburg, Mississippi, has shown that these uses of waste concrete may not impair the structural characteristics of the pavement and/or foundations. It is advisable to develop new specifications designed to permit the use of these secondary materials for the construction of pavements and foundations.

#### Suggested Guidelines for Salvage and Reclamation

Based on the above considerations, we believe that a set of broad principles for future action can be developed. These principles can serve as guidelines for regulating the U.S. Army demolition projects and improve the salvage and reclamation of demolition wastes. Accordingly, where feasible, the U.S. Army can require that contractors for all major demolition projects

- (1) Develop the necessary inventory for salvageable secondary materials and require their sale
- (2) Procure the services of a liquidation firm experienced in the auction of salvageable materials
- (3) Perform manual or mechanical brick salvage unless it can be shown that the bricks are not reusable
- (4) Where possible, test on-site separation of wastes by means of modified demolition procedures and equipment
- (5) Demonstrate selected reclamation alternatives by chosen contractors and intergovernmental cooperation.

The above guidelines could enhance the opportunities for salvage and reclamation opportunities from demolition wastes.

#### 4. ANALYSES OF DEMOLITION DATA

In this section, a discussion of the results of data collection and analyses is presented. Data collected on several demolition projects are compiled in Table C-1 (Appendix C). Such efforts at demolition data collection and analyses should be considered pioneering since no systematic documentation of such data is available to date. Demolition contractors do not have sufficient motivation or reasons for accumulating systematic data on their projects. Therefore, gaps even in the best available data are unavoidable. The resulting variability in data makes correlation of parameters difficult. These are discussed also in this section.

##### Data Collection

The data collection work was undertaken on 45 demolition projects with the assistance of several demolition contractors, who volunteered to participate in this study.\* The projects were located in

Boston, Massachusetts	Fort Carson, Colorado
Chicago, Illinois	New York, New York
Columbus, Ohio	Oklahoma City, Oklahoma
Detroit, Michigan	Presidio of Monterey, California
Dover AFB, Delaware	Fort Myer, Virginia

A majority of the projects were located around Columbus, Ohio, and were identified as civilian demolition projects. Other civilian demolition projects surveyed were located in Boston, Chicago, Detroit, New York, and Oklahoma City. The military demolition projects were located at Dover AFB, Fort Carson, and Presidio of Monterey.

Several parameters were identified that help to define a demolition project as follows:

- (1) Type of structure
- (2) Total floor area
- (3) Volume of structure
- (4) Type of demolition employed
- (5) Age of structure

---

\* A list of contractors and Army post officials who assisted in this study is provided in Appendix E.

- (6) Average floor height
- (7) Days to wreck (duration of operation)
- (8) Total cost of demolition (including waste disposal)
- (9) Distance between demolition and disposal sites
- (10) Cost of disposal
- (11) Volume of disposal trucks used
- (12) Volume of wastes
- (13) Composition of wastes (volume percent)

Concrete  
Bricks  
Wood  
Paper/boards  
Steel  
Aluminum  
Asphalt.

Data on the above parameters have been collected for each of the 45 demolition projects. The age of the structure for the majority of the projects could not be obtained. The data on "days to wreck" is also approximate. For several projects the volume of the structure had to be estimated based on floor area and average floor height. The volume of waste data is based on truckloads of waste transported. Since some trucks are sent 50 to 75 percent full, the waste volume data may have some error.

The demolition projects were identified by contacting selected demolition contractors. Some demolition contractors were first contacted by telephone. Others were contacted at the 1974 Annual Convention of the Demolition Contractors. These contractors, who volunteered to help, were further contacted to identify specific projects for which they had sufficient data on their files. A visit was then arranged to obtain the available data, to discuss their accuracy, and to make field visits to selected demolition projects. This process was used for each of the 45 demolition projects.

It should be noted that most of the data were obtained from the files and records of the contractors. In case of missing information, the contractor's judgment and memory were relied upon to fill in the gaps. The errors resulting from these judgmental factors and the understandably

inadequate record-keeping practices of the contractors have undoubtedly contributed to some bias in the data. The four military installations (three Army posts and one Air Force Base) visited to obtain data on demolition techniques, cost, and volume relationships provided some interesting highlights. At Fort Carson, for projects employing mechanical demolition, the cost of demolition and disposal was about \$0.25/ft<sup>2</sup> of floor area. At this site the structures to be demolished were well removed from any residential and otherwise occupied structures in use at the post. Thus, precautions for dust and noise control necessary during demolition work were not very rigorous. Also, the waste disposal site was located within 3 miles of the demolition site on the Army post itself. A contrasting example is that the cost of demolition at Fort Ord (Presidio of Monterey) was \$0.91 to \$1.90/ft<sup>2</sup>. Several factors contributed to this high cost of demolition.

- (1) Extremely careful dust control measures were employed during demolition since the structures were within 500 feet of senior officers' quarters.
- (2) A large amount of pavement demolition, tree removal, etc., was necessary.
- (3) The waste disposal site was located about 6 miles away from the site of demolition. The cost of disposal included dumping charges of \$1 per ton of waste dumped.

These factors should be kept in mind when interpreting the collected data. Obviously, the estimates of demolition cost, waste volume, and duration of the project to be made from any models presented in this report should be modified to specific site and situation conditions governing a particular project.

#### Data Analysis

The compiled data (see Appendix C) were reviewed in order to test the applicability of factor analysis and/or regression analysis based on the following simple relationships:

- (1) Volume of waste = f (type of structure, total floor area, volume of structure, and average floor height)

- (2) Waste composition = f (type of structure, age of structure, volume of waste)
- (3) Cost of waste disposal = f (waste composition, distance of disposal, volume of the truck)
- (4) Total cost of demolition (including disposal) = f (volume of structure, cost of waste disposal, type of structure, type of demolition).

It was found that the available data were not complete enough to warrant any sophisticated analysis with the given data. A simplified tabular and/or graphical analysis was undertaken in lieu of regression analysis.

The analysis involves setting up simple one-to-one graphical and/or tabular relationships between predictive parameters such as

- (1) Volume of waste
- (2) Composition of waste
- (3) Cost of disposal
- (4) Total cost of demolition (including waste disposal)

and known independent parameters which characterize the structure demolished or the type of demolition technique used. The analysis of the above predictive parameters and relevant conclusions are summarized below.

#### Volume of Waste

Conceptually, the volume of waste depends on the type of structure, the total floor area, the volume of structure, and its average floor height. Since the volume of the structure is generally equivalent to the product of average floor height and the total floor area, the waste volume can satisfactorily be related only to the volume of the structure and the type of structure.

The first step in establishing this relationship is to divide the waste volume by the volume of the structure. The resulting value (waste volume per unit of building) can be considered an estimate and is tabulated in Appendix C. This estimate of waste volume is plotted against the building volume in Figure 21. Based on the researchers' judgment and knowledge of the accuracy of the data, the data points that lie at the

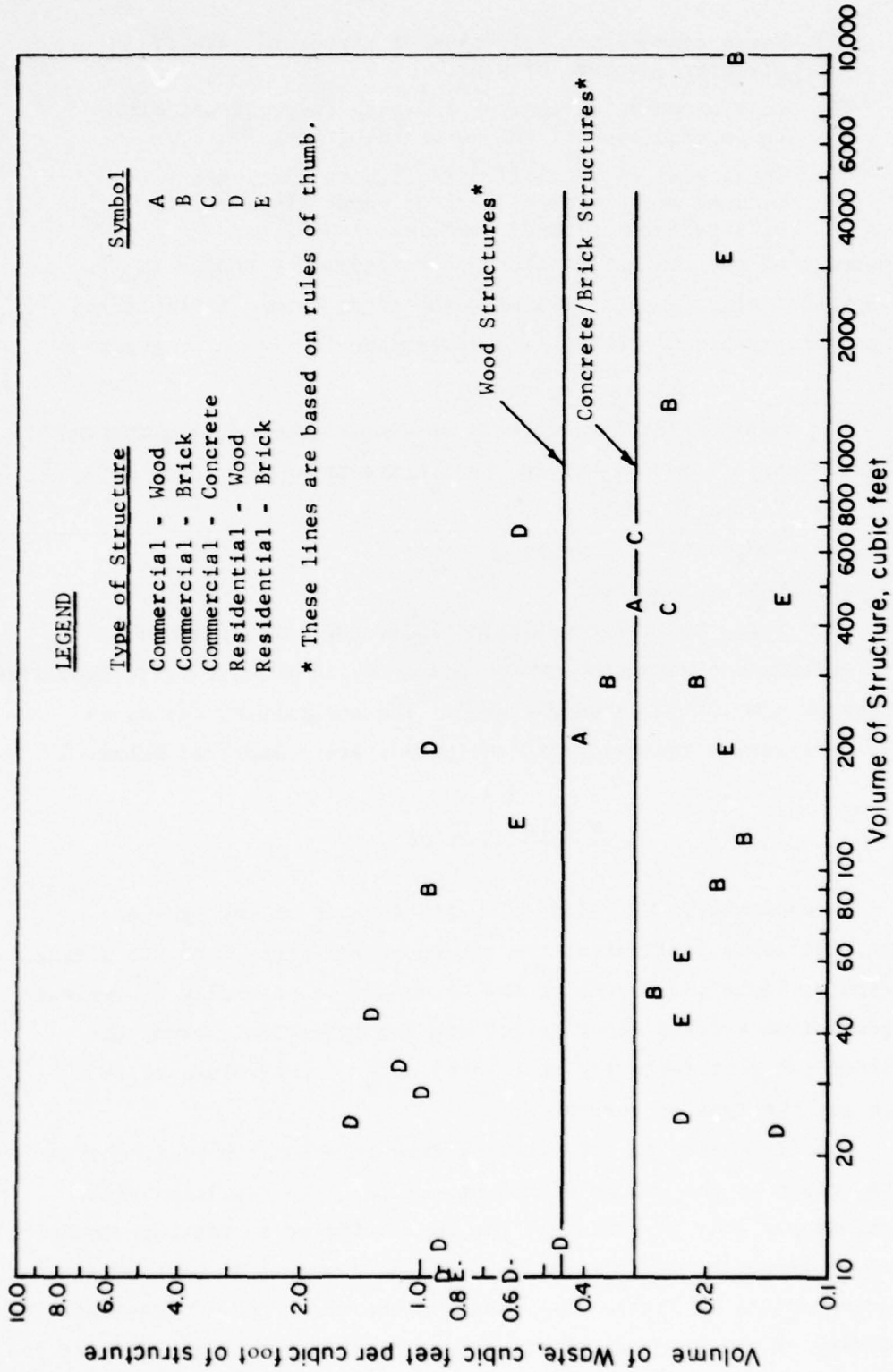

FIGURE 21. WASTE VOLUME AND VOLUME OF STRUCTURE RELATIONSHIP

extremes (high or low) can be interpreted to signify that: (1) the data are in error if too low and (2) if too high, probably inefficient transportation of waste occurred since the data on volume of waste are based on the number of truckloads of waste transported. Figure 21 shows several data points that are greater than 0.5 cu ft/cu ft of structure. Most of these data points represent inefficient transportation of demolition waste. About 25 percent of the projects suffered from this problem.

Due to the cited shortcomings in the data, it is necessary to exercise careful judgment in drawing conclusions. From the available data, it is possible to support the following rules of thumb:

- (1) The majority of the brick and concrete structures have a waste generation rate equal to or less than 0.3 cu ft/cu ft of structure. This is a typical waste generation rate for brick or concrete structures.
- (2) The representative or typical waste generation rate for wooden structures is somewhat higher than the brick or concrete structures; the average rate for the wooden structures is about 0.45 cu ft/cu ft of structure.
- (3) The data show that there has been considerable inefficiency involved in the actual transportation of demolition wastes due to partial loading of trucks.

Figure 22 shows another graphical plot of waste volume in cu ft/cu ft of total floor area versus the total floor area of the structure.\* This plot indicates also that the waste volumes of brick and concrete structures are generally lower than the wooden structures. The typical waste volume relationship to the total floor area is as follows:

- (1) The typical waste generation rate of brick or concrete structures is about 3.0 cubic feet per square foot of floor area
- (2) The typical waste generation rate of wooden structures is about 4.5 cubic feet per square foot of total floor area.

The above conclusions from Figure 22 agree closely with the earlier conclusions from Figure 21 if an average floor height of 10 feet is assumed.

---

\* The data are expressed on the basis of both volume of structure and floor area because more often only one of these two parameters is known. Usually only the floor area is known.

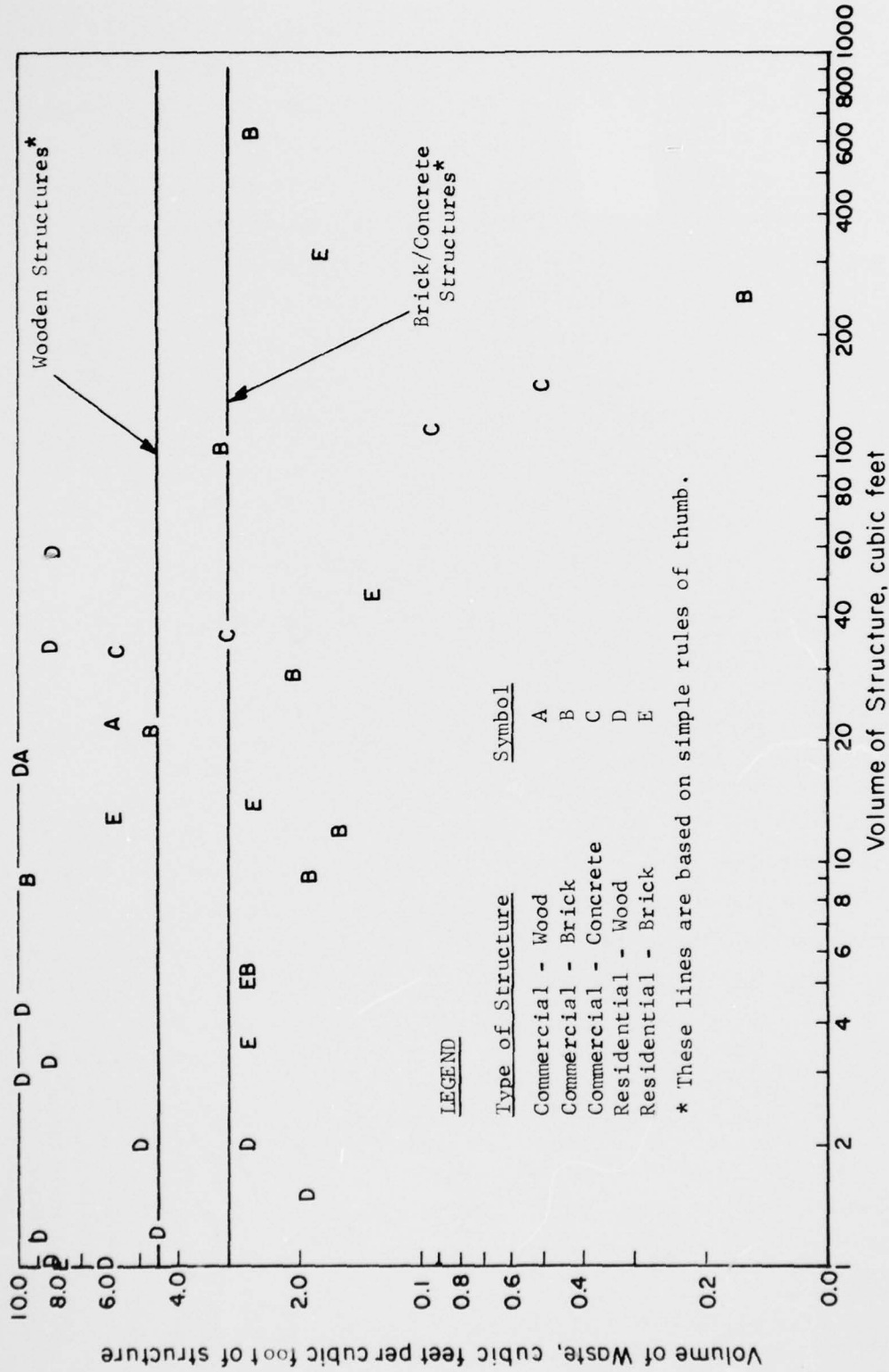

FIGURE 22. WASTE VOLUME AND FLOOR AREA RELATIONSHIP

### Waste Composition

Waste composition is generally a function of the type of structure. The composition reported by different contractors for the same type of structures does not vary significantly. The representative demolition waste composition for various types of structures, identified from the data in Appendix C, is summarized in Table 10. The data show that a wooden residential structure contains more wood than an old commercial wooden structure. On the other hand, a commercial brick structure usually has more brick than a residential brick structure.

### Cost of Solid Waste Disposal

The cost of disposal is the sum of the unit costs of collection and disposal in dollars per cubic yard of waste transported (\$/yd<sup>3</sup>). The disposal cost data cover several cities; as such, all cost data have been adjusted to the national average values based on the ENR Construction Cost Indices, commonly employed for cost analysis of construction and demolition activities. The cost figures shown in Appendix C are the adjusted cost of disposal. This cost is then compared with the corresponding distance of disposal site. As a result of this comparison, the cost of disposal is further modified based on the following formula:

$$\text{Adjusted cost of disposal (\$/cu yd/10 miles)} = \frac{10.0 \times [\text{Cost of disposal (\$/cu yd)}]}{\text{Actual distance of disposal site (miles)}}$$

This modified cost permits comparison of cost for several cities on the same basis. The estimated cost of disposal in \$/cu yd/10 miles is then plotted against the volume of waste, as shown in Figure 23. Each data point on the plot is also identified by the size or volume of truck used for waste disposal.

The scatter diagram shows that in the vast majority of the projects, the cost of disposal was \$2 or less per cubic yard per 10 miles (distance of disposal site). It appears that when 20-cubic-yard-capacity trucks are employed for disposal, the majority of the cost data show

TABLE 10. REPRESENTATIVE DEMOLITION WASTE COMPOSITION<sup>(a)</sup>

Type of Structure	Concrete, percent	Bricks, percent	Wood, percent	Paper Board, percent	Steel, percent
(1) Residential, Wood	(b)	15.0	80.0	2.5	2.5
	10.0	10.0	77.0		3.0
(2) Commercial, Wood	(b)	22.5	75.0		2.5
	20.0	17.0	60.0		3.0
(3) Residential, Brick		50.0	45.0	3.0	2.0
(4) Commercial, Brick	(b)	82.0	13.0	2.0	3.0
	12.0	53.0	32.0		3.0
(5) Commercial, Brick (multistory)	38.0	57.0	3.0		2.0
(6) Commercial, Concrete	50.0	20.0	20.0	7.0	3.0

(a) Derived from analyses of data in Appendix C.

(b) Some structures do not contain any concrete while other structures in these categories contain up to 10 percent concrete. Similar comments apply to wood, brick, etc. The two sets of numbers are generated on the basis of one containing some concrete and the other not containing concrete at all.

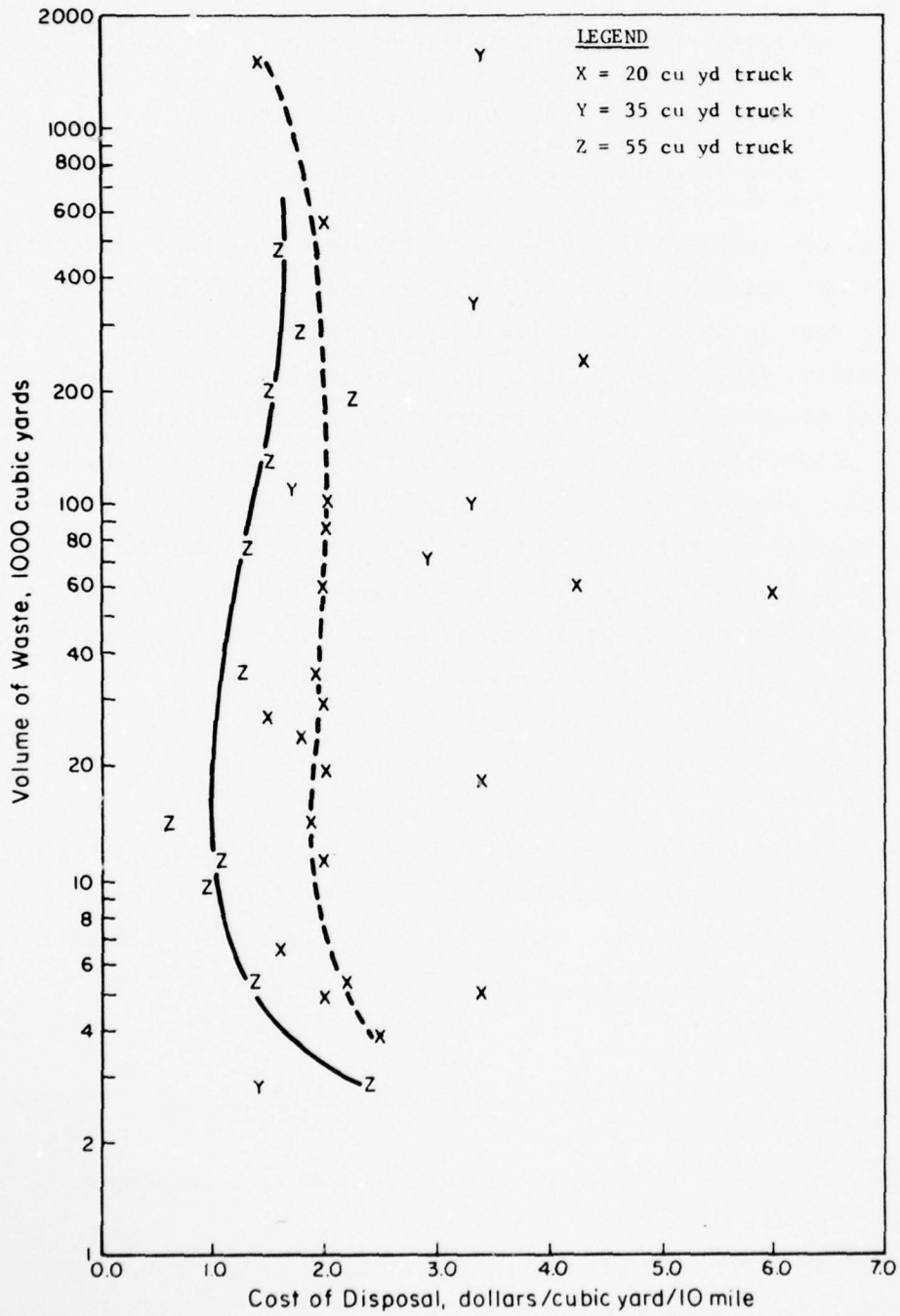

FIGURE 23. COST OF DISPOSAL AND WASTE VOLUME RELATIONSHIP

disposal cost at  $\$2/\text{yd}^3/10$  miles distance.

The scatter diagram also shows that:

- (1) The 55-cu yd trucks generally permit the most efficient (low cost) disposal of wastes, costing about \$1.50 per cu yd per 10 miles
- (2) The 20- and 35-cu yd trucks have been found at times to be very inefficient. The 20-cu yd trucks are used inefficiently more often than the 35-cu yd trucks.

In the future, due to the high energy costs, the operating cost differences between the small and the large trucks will become increasingly acute. Thus, greater care in selection of truck size will be important.

Finally, it can be concluded that a reasonable cost of demolition waste disposal (June 1975 costs adjusted to national average prices) is \$2 per cu yd per 10-mile distance to disposal. However, the cost may vary between \$1.50 to \$2.50. Disposal costs greater than \$2.50 should be considered generally excessive and indicative of inefficient use of equipment. Examples of high disposal costs have been presented in Table 11. It may be useful to examine waste disposal operations at selected posts in order to establish more economic disposal strategies.

#### Cost of Demolition

Reasonably good data on total cost of demolition were available for about 40 demolition projects. Unit cost of demolition for each project has been estimated based on the following two simple formulas:

$$\text{Unit demolition cost (dollars/ cu ft of structure)} = \frac{\text{Total cost of demolition}}{\text{Volume of structure}}$$

$$\text{Unit demolition cost (dollars/ sq ft of floor area)} = \frac{\text{Total cost of demolition}}{\text{Total floor area}}$$

The estimated unit costs of demolition projects have been tabulated in Table C-1 of Appendix C.

The unit costs for all cities are adjusted to the national average prices, using adjustment factors shown in Table 12. The adjustment factors are based on the city construction cost indices developed by the Engineering News-Record journal.

TABLE 11. DEMOLITION WASTE DISPOSAL COSTS AT SELECTED ARMY POSTS

Project	Distance of Disposal Site, miles	Cost of Disposal, \$/cu yd	Cost of Disposal \$/cu yd/10 mile
Ft. Meyer #1	25	18.00	7.20
Ft. Meyer #2	25	8.00	3.20
Dover AFB #1	20	5.00	2.50
Dover AFB #2	12	3.50	2.91

TABLE 12. COST ADJUSTMENT FACTORS BASED ON ENGINEERING NEWS-RECORD INDICES

Name of City	ENR Construction Cost Index Dec, 1974	Cost Adjustment Factors
Boston, Massachusetts	2160	103
Chicago, Illinois	2205	105
Columbus, Ohio	2120	101
Denver, Colorado	1670	76
Detroit, Michigan	2396	114
New York, New York	2568	122
Oklahoma City, Oklahoma	1596	76
San Francisco, California	2509	120
Baltimore, Maryland	1824	87
U.S. average	2099	100

The unit demolition cost is then separately plotted against corresponding volume of structure and total floor area, as shown in Figures 24 and 25. An examination of the plots shows that there are two separate cost trends, one relating to efficient demolition of wooden structures and the other relating to brick/concrete structures. Understandably, the demolition cost of wooden structures is generally lower than brick/concrete structures. These costs are based on the use of mechanical demolition techniques.

Figure 24, for example, indicates the relationship between volume of structure and the cost of demolition expressed in dollars per cubic foot of structure. A minimum cost line has been drawn linking the most efficient demolition projects for wooden structures. The wooden structures that are demolished at higher unit costs generally appear well above this line. As shown in Figure 24, there have been many inefficient demolition operations which could have been economized.

A similar analysis of the brick and concrete structures appears to indicate the existence of a distinctly different minimum cost trend line. This line lies above the cost trend line for wooden structures.

Obviously, these trend lines or models have been developed based on limited data. Also, no statistical test has been used to validate the two models shown in Figure 24. As such, they are considered tentative models for the prediction of demolition cost.

In Figure 25, similar relationships or models have been developed that relate total floor area to unit demolition cost expressed in dollars per square foot of floor area.\* These models are quite similar to the models in Figure 24, and may be used for predictive purposes. However, due to the lack of adequate statistical testing, the models should be considered tentative, i.e., subject to future verification.

---

\* When the average height per floor or story is 10 feet, the costs per unit floor area multiplied by 10 will provide cost per unit volume of structure. If the floor height is not 10 feet, but an unknown "h" feet, then it will be useful to have the data in \$/sq ft floor area which can be multiplied by the measured "h" to get \$/cu ft of structure.

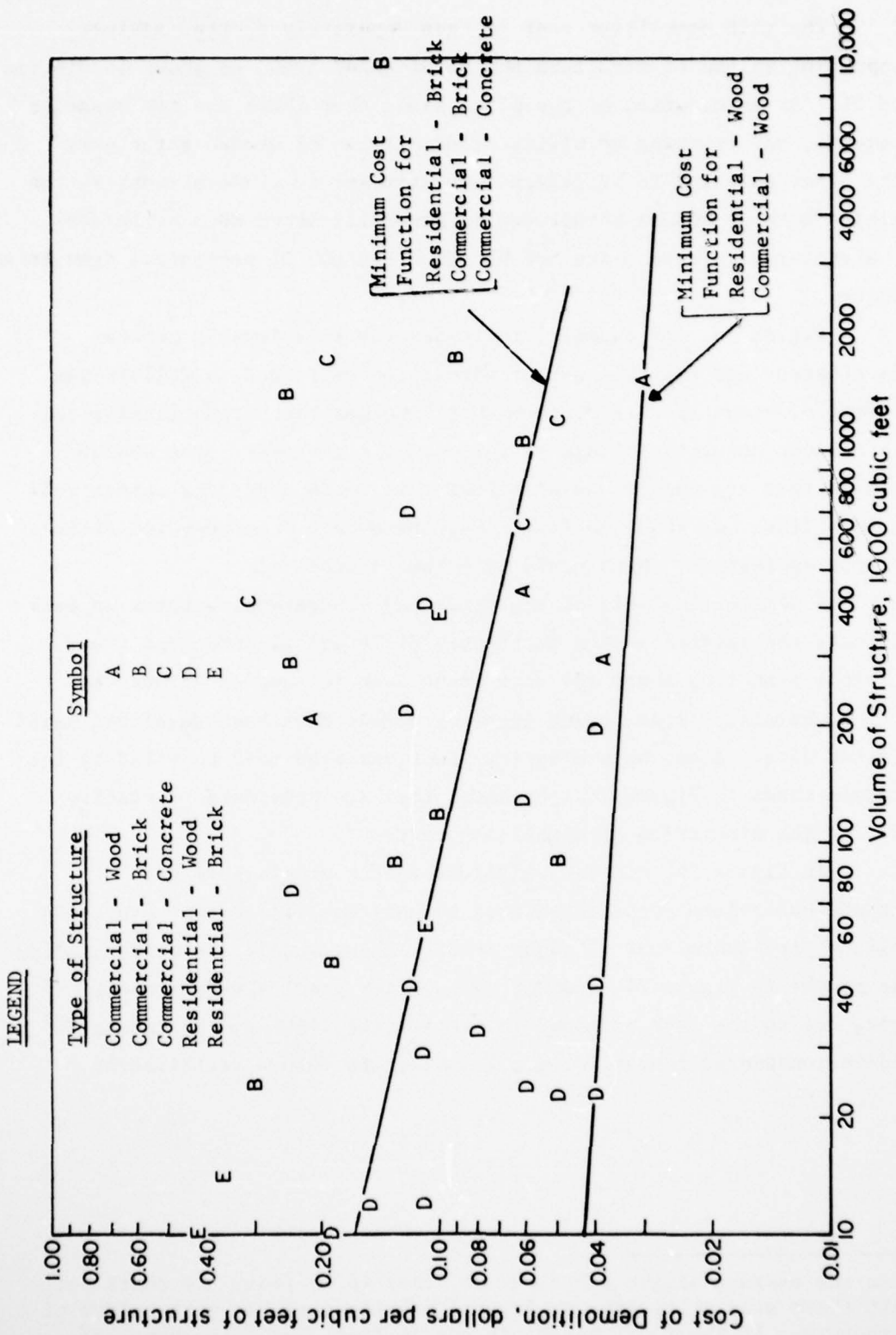

FIGURE 24. DEMOLITION COST AND VOLUME OF STRUCTURE RELATIONSHIP

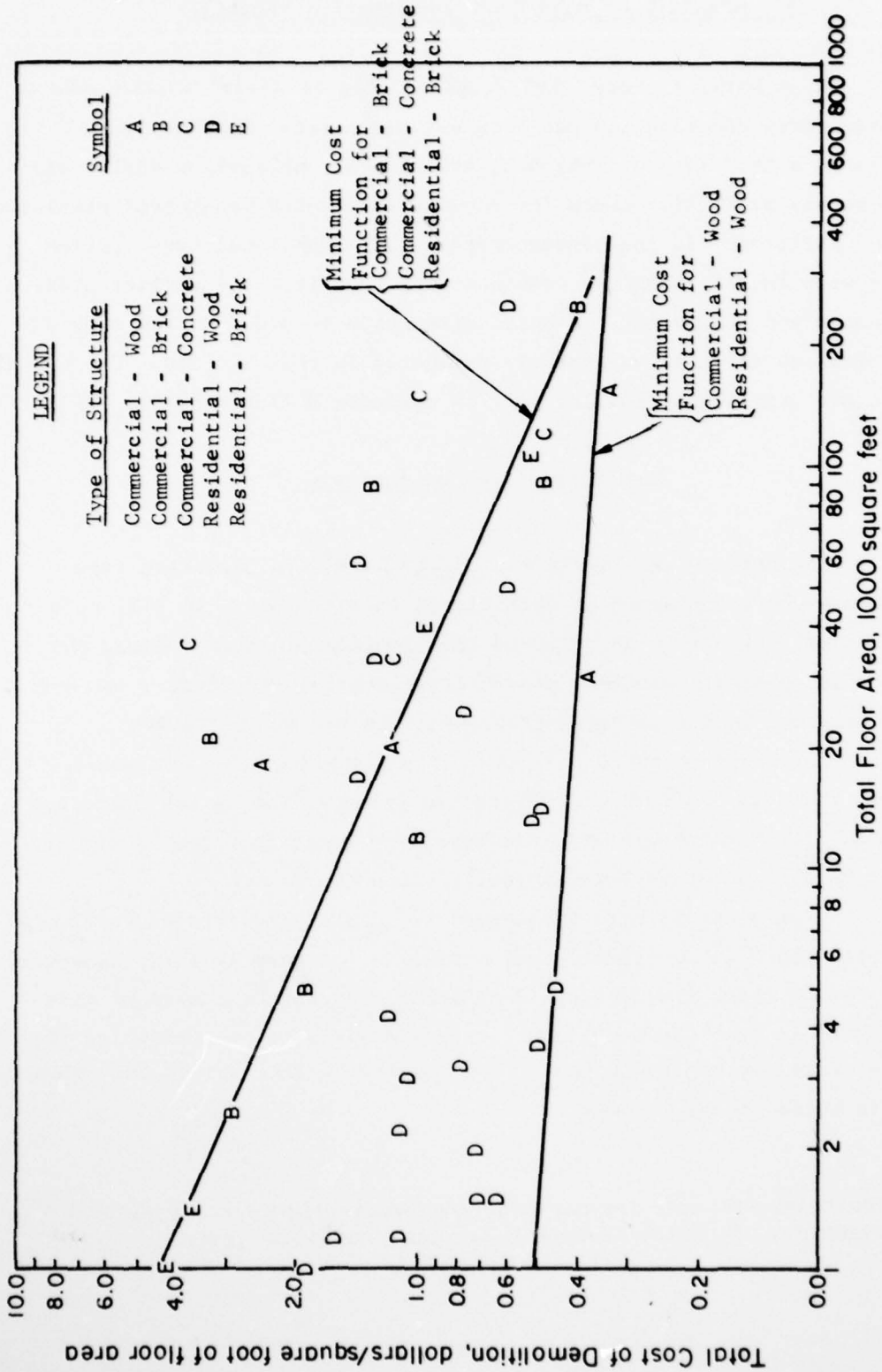

FIGURE 25. DEMOLITION COST AND TOTAL FLOOR AREA RELATIONSHIP

## 5. ANALYSIS OF DATA FROM CONSTRUCTION PROJECTS

In an earlier study (CERL Technical Report N-14)<sup>5</sup> an analysis of wastes from Army construction projects was presented. That analysis demonstrated a need for collection of additional construction waste data to improve the predictive tools for construction waste management presented therein. Therefore, in the present report, six additional construction projects were investigated and combined with data from the earlier study after review and refinement. A brief discussion of new data and some of the conclusions the data suggest are presented in this Section. The actual raw data are compiled in tabular form in Appendix D (Table D-1).

### Data Collection and Analysis

The data on construction projects have been collected from contractors who volunteered to participate in the study. In all, data have been collected from 14 selected construction projects. Among the construction projects studied, nine are residential structures, two are gymnasiums, one is a commercial structure, and two are airfields.

It should be noted that six out of 14 structures are non-military (civilian) structures located in Columbus, Ohio, and Detroit, Michigan. The remaining eight structures are located at Army posts such as Fort Hood, Texas, and Fort Campbell, Kentucky.

A substantial effort was made to identify additional horizontal structures, such as construction of airfields or parking lots. However, only a few of these projects could be identified in the course of this study; and in most cases the contractor's assistance in furnishing the required data was not sufficient. The results of analysis of the collected data are presented as follows.

<sup>5</sup> "Predictive Criteria for Construction/Demolition Solid Waste Management," Technical Report N-14, CERL, November 1976.

### Volume of Waste

A careful review of the data tabulated in Appendix D indicates that the volume of wastes generated by construction of an average residential structure is about 460 cubic yards per acre\* of total erected floor area. Since only one commercial structure is included in this survey, it is not possible to establish differences, if any, between residential and commercial structures. Due to the lack of information, it is suggested that the same waste generation factor be used, both for residential and commercial structures. The volume of waste relationship for concrete and wood frame structures is approximately of the same order.

In addition, a few other tentative conclusions may also be drawn from the above data. These conclusions are:

- (1) Gymnasiums have a high waste generation rate because of their large volume for a given floor area. The average waste generation rate for gymnasiums is about 2000 cubic yards per acre of erected floor area.
- (2) Remodeling activities generate much lower waste volumes. For instance, one remodeling project at Fort Campbell generated about 300 cubic yards of solid wastes per acre of floor area rehabilitated.
- (3) The volume of waste generated during airfield construction is substantially lower than that for residential construction. Based on two projects studied, it appears that the waste generation rate for airfield construction is about 60 cubic yards per acre.

These tentative waste generation factors may be employed to predict on-site volumes of solid waste at construction projects.

### Composition of Waste

The composition of solid wastes generated varies with the type of construction. For example, the composition of solid waste generated by concrete structures is greatly different from that of the wood frame

---

\* 1 cu yd/acre =  $6.21 \times 10^{-4}$  cu ft/sq ft.

structures. Typical waste compositions are:

<u>Components</u>	<u>Concrete Structures, percent</u>	<u>Wood Frame Structures, percent</u>
Concrete	67	5
Bricks	10	14
Wood	10	68
Paper board	10	11.5
Scrap iron	3	1.5
Scrap aluminum		

The above percentages are approximate and only represent the order of magnitude of each component in the waste.

#### Cost of Disposal

The adjusted cost of disposal is the estimated unit cost of disposal (expressed in \$/cu yd) when the waste is transported exactly 10 miles for final disposal. The disposal costs have been found to vary from \$2.50 per cu yd per 10 mile to \$6.88 per cu yd per 10 mile. The most efficient disposal cost is \$2.50/cu yd/10 mile. It is suggested that the disposal technique at an Army post should be carefully reviewed in cases where the disposal costs are higher than \$2.50/cu yd/10 mile. However, the choice of truck size employed by contractors is often beyond the control of the Army. It appears, therefore, that the Army can only encourage contractors to economize disposal cost by alerting them to the inefficiency involved in waste disposal by use of small vehicles.

## 6. SUMMARY AND CONCLUSIONS

Demolition of obsolete structures to make room for new structures is a continuing process in any active Army installation. Significant funds are expended for demolition of barracks, mess halls, and other obsolete structures. In many instances, the demolition budget can be reduced if a carefully planned salvage and recycle operation is conducted. At Fort Ord, California, it was reported during the visit for data collection that many of the barracks marked for demolition were sold to civilians. These barracks were cut in half and transported by the buyer for re-erection. The reported savings in the demolition budget at Fort Ord in this specific situation exceeded 90 percent. While such savings may not always be possible, a planned effort to salvage will help: (1) reduce the demolition budget, (2) extend the resources (wood, concrete, metals, etc.) of the nation, (3) diminish the problems of solid waste disposal, (4) save the petroleum-based energy employed in the operation of bulldozers and trucks for transportation of solid waste and other heavy equipment. Therefore, placing more emphasis on salvaging could yield very attractive rewards. In this report, detailed methods of brick salvaging are presented.

Demolition technology is an art. There are many demolition techniques in current use. Manual demolition, mechanical demolition, and demolition with explosives are more commonly employed techniques. Equipment and details of these methods are presented in significant depth in this report. The environmental and safety aspects of demolition which include dust emission into the atmosphere during all types of demolition and release of flying objects (ejecta) during demolition with explosives are discussed in detail. Methods of abating these problems are detailed.

It is noted that the total cost of demolition varies widely and includes two components: (1) cost of demolition and (2) cost of solid waste disposal. Cost data for 45 demolition projects were collected and analyzed. The cost of disposal can represent up to 50 percent of the total demolition cost. As such, it will be desirable to explore methods to reduce disposal costs at Army posts. In many instances, when a disposal site is not provided on the Army post itself, contractors may resort to use of small volume haul trucks (20 cu ft capacity) instead of

AD-A033 646

CERL TR-N-15

OCT 76

FLD/GP 13/2 13/3

DEVELOPMENT OF PREDICTIVE CRITERIA FOR DEMOLITION AND CONSTRUCTION  
SOLID WASTE MANAGEMENT. (U)

K.S. MURTHY, ET AL.

UNCLASSIFIED BATTELLE COLUMBUS LABS., OHIO.

2 OF 2  
AD-A  
033 646



END  
DATE  
FILMED  
2-8-77  
NTIS

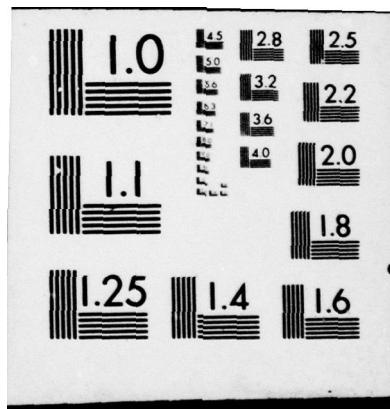

larger trucks. Also, when large trucks are used, the trucks may be filled only partially. Both these practices are wasteful and increase the cost of disposal from 20 to 40 percent of the cost of a well planned, efficient disposal operation. The following conclusions may be drawn from this study.

#### Conclusions

- (1) Mechanical demolition is the most widely practiced method in both civilian and military projects. In military projects, usually single- or two-story structures are demolished by use of scoopdozers. Other mechanical methods are listed in Table 7. For very tall structures, crane and ball or explosive demolition techniques are employed.
- (2) The approximate rate of solid waste generation for wood structures (old barracks, etc.) is 4.5 cu ft/ft<sup>2</sup> of floor area before demolition. For brick structures, the solid waste generated is about 3.0 cu ft/ft<sup>2</sup> of floor area.
- (3) A predominantly brick structure can contain up to 80 percent brick by volume. Thus, an active brick salvaging program could eliminate much of the solid wastes resulting from demolition of this type of structure.
- (4) A predominantly wood structure (barracks, for example) contains up to 90 percent wood. A careful salvaging operation can provide high-quality lumber and reduce solid waste generation. Alternately, the wood can be used as fuel where coal-fired heating plants are employed.
- (5) Well-planned salvaging efforts can result in significant cost savings.
- (6) A reasonable cost of waste disposal appears to range from \$2 to \$2.50/cu yd/10-mile haul (based on December 1974 prices and costs adjusted to national average ENR Index). Thus, when disposal costs higher than about \$3 are quoted, a careful evaluation of the disposal technique may be useful.
- (7) Cost of demolition is a function of the volume of structures or floor area in a given project. The unit cost of demolition is smaller when large floor areas are being demolished. The

plot of floor area versus cost of demolition in Figure 25 clearly demonstrates the relationship.

- (8) It appears that sufficient advantages exist to plan a demolition project to optimize the cost of the entire operation with special emphasis on salvage and reclamation.

Construction waste data were not available as extensively as demolition data. Waste data on 14 construction projects were analyzed after including earlier data from CERL Technical Report N-14.<sup>6</sup> In fact, the data on construction of airfields are scant. The cost of disposal of construction wastes is not significantly different from disposal cost of demolition waste. For both types of waste the average cost is \$2.50/cu yd/10 miles. Other conclusions from the study of 14 construction projects are:

- (1) The rate of construction waste generated by residential building activities is about 500 cu yd/acre of erected structure (0.3 cu ft/sq ft). This is about only one-tenth of the volume that would be generated by demolition of the same structure.
- (2) Construction of gymnasiums generate the highest volume of construction solid waste among the construction projects studied. This rate (1.2 cu ft/sq ft) is about 40 percent of demolition wastes from the same type of structures.
- (3) The problems of generation and disposal of construction waste are minor in comparison with demolition solid waste management problems.

<sup>6</sup> "Predictive Criteria for Construction/Demolition Solid Waste Management," Technical Report N-14, CERL, November 1976.

Recommendations

Based on this study it is recommended that:

- (1) Cost and waste volume relationships presented in this study be tested by applying the models to a demolition project.
- (2) A study of possible use of wood wastes in coal-fired boilers be made when large volumes of wood-based structures are to be demolished.

REFERENCES

Anon., "The Loizeaux Family Blasts its Way to the Top", Engineering News Record, August 10, 1972.

Briggs, Joseph, "Military Engineering Application of Commercial Explosives", Army Engineer, Waterways Experiment Station, Explosives Excavation Research Laboratory, Livermore, California (October, 1972) p 157.

Carpenter, J. W. Jr., and Cragg, T. M., "Controlled Blasting for Concrete Removal", The Military Engineer, January-February, 1973.

DeFrank, P., et al, "Explosive Technology - A New Tool in Offshore Operations", Paper No. SPE 1602, American Institute of Mechanical Engineers - Society of Petroleum Engineers, 1966.

Dennis, J. A., "Demolition of Concrete Locks on the Ohio River (Deliberate Phase)", Army Engineer Research and Development Labs., Fort Belvoir, Virginia (July, 1962) p 150.

Dennis, J. A., "Steel Cutting With High Explosive Charges," Army Engineer Research and Development Labs, December 1965, p 172.

Department of the Army, "Explosives and Demolitions", Manual No. FM5-25, U.S. Army Engineer School, Fort Belvoir, Virginia, February, 1971.

Department of the Army, "Calculation and Placement of Explosives", Programmed Text Stock No. A 143-BO-PT-002, U.S. Army Engineer School, Fort Belvoir, Virginia, August, 1973, p 111.

Du Pont Company, "Blasters' Handbook", E. I. du Pont de Nemours & Company, Inc., Wilmington, Delaware, 1969.

Duane, H., Salvage and Wrecking Journal, Hingham, Massachusetts (November, 1974).

EMACO, Inc., "A New Method for Breaking Rock and Concrete", A Staff Report, 111 Van Riper Avenue, Elmwood Park, New Jersey, 1974.

Housing & Urban Development, "Noise Assessment Guidelines: Technical Background", HUD Report No. TE-NA 172, Washington, D.C., September 1970.

"Predictive Criteria for Construction/Demolition Solid Waste Management", Technical Report N-14 (U.S. Army Construction Engineering Research Laboratory, 1976).

Rahe, R. H. and Ransom, R. S., "Stressful Underwater Demolition Training - Serum Urate and Cholesterol Variability", Navy Medical Neuropsychiatric Research Unit, San Diego, California (1967) p 6.

REFERENCES  
(Continued)

Skinner, J. T., et al, "Protection of Environment During Demolition Activities", U.S. Army Waterway Experiment Station, Vicksburg, Mississippi, December, 1973.

U.S. Department of Labor, "Safety in Industry - Instructor Outline: Demolition", Safety Training Programs Manual, Washington, D.C., 1967.

U.S. Environmental Protection Agency, "Noise Facts Digest", Contract 68-01-0512, Final Report, June, 1972.

U.S. Environmental Protection Agency "Public Health and Welfare Criteria for Noise", US EPA, Washington, D.C., July, 1973.

U.S. Environmental Protection Agency, "Background Information on National Emission Standards for Hazardous Air Pollutants - Proposed Amendments to Standards for Asbestos and Mercury", Report No. EPA 450/2-74-009a, Research Triangle Park, N.C., October, 1974.

Wilson, D. G., et al, "An Investigation of the Potential for Resource Recovery from Demolition Wastes", Interim Summary Report, Massachusetts Institute of Technology, Cambridge, Massachusetts, August, 1975.

Wilson, D. G., et al, "Demolition Debris: Quantities, Composition, and Possibilities for Recycling",

Wittish, R., "Georgia Crane Operator Recalls Working Days", Wrecking & Salvage Journal, pp 2 and 12, June, 1975.

BIBLIOGRAPHY

Anon., "Blaster's Handbook", E. I. duPont de Nemours & Company, Inc., Wilmington, Delaware, 1969.

Anon., "Minimum Safety Requirements 1968 Edition", Aircraft Corporation, Connecticut Research Lab., East Hartford, Connecticut (1968) p 101.

Anon., "Housing-Denver SMSA: Inventory, Projections, Problems, and Issues", Denver Regional Council of Governments, Colorado (November, 1969) p 101.

Anon., "Demolitions, Blasting Caps", Army Test and Evaluation Command, Aberdeen Proving Ground, Maryland (May, 1971) p 17.

Anon., "Ignition System Demolition", Army Test and Evaluation Command, Aberdeen Proving Ground, Maryland (July, 1971) p 17.

Anon., "Demolition Equipment, Explosive Initiating Electronic and Non-electronic", Army Test and Evaluation Command, Aberdeen Proving Ground, Maryland (July, 1971) p 14.

Anon., "Demolitions and Demolition Equipment", Army Test and Evaluation Command, Aberdeen Proving Ground, Maryland (February, 1972) p 6.

Anon., "Demolition Initiating Equipment", Army Test and Evaluation Command, Aberdeen Proving Ground, Maryland (February, 1972) p 19.

British Standards Institution, "British Standard Code of Practice - CP94: 1971 Demolition", 2 Park Street, London, England, 1971.

Bureau of Labor Standards, "How to Inspect Chart - Demolition", Report No. HTIC-LS-356 OOS-12.64, U.S. Department of Labor Safety Training Program, Washington, D.C., 1964.

Bureau of Labor Standards, "Occupational Safety Aid - Demolition Operations", Report No. OSA-LS-352 OOS-5.65, U.S. Department of Labor Safety Training Programs, Washington, D.C., 1965.

Bureau of Labor Standards, "Safe Work Guide", Report No. SWG-LS-295 OOS-12.65, U.S. Department of Labor Safety Training Programs, Washington, D.C., 1965.

Dennis, J. A., "Steel Cutting with High Explosive Charges", Army Engineer Research and Development Labs., Fort Belvoir, Virginia (December, 1965) p 172.

BIBLIOGRAPHY  
(Continued)

Dick, R. A., "Factors in Selecting and Applying Commercial Explosives and Blasting Agents", Report No. BMIC 8405, U.S. Department of Interior, Bureau of Mines, Washington, D.C., 1968.

Demolition Industry Conciliation Board, "Constitution of the Board and Working Rule Agreement for the Demolition Industry in England, Scotland, Wales", 2 Bankart Avenue, Leicester, England, 1967.

Duane, H., "Demolition Operations", M.S. Thesis, University of Massachusetts, 1960.

Feinstein, D. I., "Debris Distribution", IIT Research Institute Technology Center, Chicago, Illinois (March, 1966) p 2.

Griffiths, P. A., "Ball and Chainmen Swing to Plant Power", Contract Journal, (May 10, 1973) p 41-45.

Martin, E. S. and Crump, E. W., "Experimental Data Forming the Basis for the Bombing Tables BT-1100-A-3 for the Bomb, Demolition", Ballistic Research Labs., Aberdeen Proving Ground, Maryland (April, 1942) p 44.

Mayes, Truett, "Procedures for the Demolition of Vacant Substandard Buildings", South Plains Association of Governments, Lubbock, Texas (May, 1972) p 67.

Mueller, O. O., "List of the Organizations Concerning with Blasting Techniques in Construction", Municipal Council of Budapest, Budapest, Hungary, 1974.

Nicholson, J. D., "SHE Heat Transfer System Demolition", Atomics International, Canoga Park, California (August, 1965) p 25.

Niehaus, F. A., "Packaging MK 45 MOD Demolition Shaped Charge", Naval Ammunitions Depot Crane, Indiana (October, 1967) p 19.

Roberts, Leo, "Deficiency Investigation of the 1-LB, TNT Demolition Block Charge", Picatinny Arsenal, Ammunitions Engineering Directorate, Dover, New Jersey (October, 1966) p 2.

Reno, F. V., and E. S. Martin, "Flight Characteristics of Incendiary Bombs and Procedures for Securing Coincident Centers of Impact of Incendiary and Demolition Bombs", Ballistic Research Labs., Aberdeen Proving Ground, Maryland (May, 1943) p 41.

William J. Stanley and Associates, Inc., "Task Outline - Code of Recommended Practices for Environmental Protection in Construction, Building Maintenance, and Demolition Industry Practices, Chicago, Illinois.

BIBLIOGRAPHY  
(Continued)

U.S. Department of Interior, "Environmental Guidebook for Construction", U.S. Government Printing Office, Washington, D.C. (1974) p 61.

Vandersluis, H. J., "Hasty Demolition of Concrete Structures", Army Engineer Research and Development Labs., Fort Belvoir, Virginia (January, 1971) p 125.

Ward, J. W., "A Guide to Facilitate the Control of Environmental Degradation During Construction Operations", Division of Construction, Arizona State University, Tempe, Arizona.

## APPENDIX A

ABATEMENT AND CONTROL OF ENVIRONMENTAL IMPACTS

Demolition of buildings has many adverse environmental impacts resulting from:

- (1) Ejecta
- (2) Air blast
- (3) Ground motion/vibration
- (4) Dust and asbestos emissions
- (5) Noise
- (6) Explosion products
- (7) Air pollution (from burning of wastes)
- (8) Waste of resources
- (9) Accidents.

The adverse impacts should be abated and/or controlled to minimize all damages or inconveniences resulting therefrom. The potential abatement and control alternatives for each type of impact are discussed below.

Ejecta

There are many solutions to the ejecta problem in explosive demolition. Demolition companies have used the following methods as appropriate:

- (1) Blast nets or meshes (such as cargo nets, chain-link fence) are used in the vicinity of the charge to block the flight of debris
- (2) Temporary blast walls of plywood (up to 40 feet high) may be built around blast area to confine the ejecta
- (3) Loose objects in the vicinity of the explosion are removed so that they will not become ejecta
- (4) In building demolition, if possible, the charges are placed in a confined area, such as the basement
- (5) Use of individual small charges with delays (instead of one large charge) to reduce the amount of kinetic energy imparted to the ejecta

- (6) Combinations of several of the preceding methods to greatly reduce or virtually eliminate the ejecta hazard.

#### Air Blast

The demolition industry does not, as a routine, monitor the air blast overpressure levels. The blasting industry, through research and experience, has established several practices which can help to reduce the peak air blast overpressures. These practices are as follows:

- (1) The smallest practical explosive charge should be used in order to minimize blasts.
- (2) Proper timing of delays can also be used to reduce air blast from a row charge or an array detonation. However, the timing should be adjusted to prevent reinforcement of blast waves.
- (3) The explosion should be confined by some means, e.g., burying the charge, tamping with sand bags, or submerging it (if practicable).
- (4) To prevent focusing of the air blast wave, explosions should be accomplished when weather conditions are favorable.
- (5) Packing sandbags around explosive charges, using blast walls, or placing charges in a confined area such as a building basement can be used to dampen the blast wave and reduce the peak overpressures at locations removed from the explosion.
- (6) If a small amount of explosive is used in a subsurface explosion, but a large amount of detonating cord is used to initiate the main charge, it is possible that the peak air blast overpressures may well be generated by the detonating cord. Solutions to this problem are:
  - (a) To bury the detonating cord
  - (b) Use a detonating cord with a small amount of explosive per foot of cord
  - (c) Use a blasting cap rather than detonating cord to initiate the explosive.
- (7) Windows of surrounding buildings are often susceptible to damage from air blast. Protection can usually be provided by boarding up the windows. Care should be taken in the boarding up process to allow the boarding to deflect without touching the glass. When practicable, windows may be opened so as to minimize the

total surface area of glass exposed to the blast. Expedient methods of limited value include taping panes in a crisscross fashion; this is particularly helpful where panes may already be cracked. Parking trucks, trailers, or other large objects in front of large storefront-type windows (object should be placed between the explosion and the window) to partially absorb and reflect the blast wave can provide some protection.

- (8) The use of completely backfilled (fully stemmed) charge holes in a subsurface explosion will reduce air blast effects, but will increase ground motion levels.
- (9) Fish kill from explosions near or in waterways can be minimized by driving fish away from the detonation area prior to the explosion; this can be accomplished by personnel in the water or by mechanical means.

#### Ground Motion

The blasting industry is more concerned with ground motion effects from an explosion than any of the other effects generated. This is due to the fact that ground motion will vary from one job to another because ground motion levels are highly dependent on the transmission characteristics of the transmitting medium. Several methods the industry utilizes to minimize ground motion are summarized below:

- (1) Small charges detonated at a sufficient distance from the ground or not directly coupled to the ground will not produce damaging levels of ground motion.
- (2) Millisecond-delay blasting can be used to decrease the vibration level from blasting, because it is the maximum charge weight per delay interval, rather than the total charge, which determines the resulting amplitude.

The blasting industry normally uses consultants to predict ground motion levels and to monitor the levels during the explosion. This protects the industry from damage claims and helps to insure that effects on the surrounding environment are minimized. When demolition activities approach yield levels that are likely to cause damage from ground motion, consultants should be retained in order to assure safety of operation.

### Dust and Asbestos Emissions

Dust poses a serious problem on most demolition projects. It is, therefore, important to consider measures that would reduce the generation of dusts. Also, on certain projects asbestos dust may be generated as a result of stripping friable asbestos materials used for insulation or fireproofing. Because of the serious health hazards resulting from asbestos, it is important to control the emission of asbestos dust. The required controls for dust and asbestos emissions are outlined below:

(1) Dust control methods

- (a) Effective dust control may be accomplished when demolition is undertaken during rains and/or during periods of low wind velocity. Explosive demolition should preferably be undertaken during a rain.
- (b) Wetting down structures and roads can greatly abate the dust problem.
- (c) Placing covers over open-bed trucks and dump trucks will reduce in-transit dust and the falling debris problem.
- (d) Dust from roads and bare areas may be controlled by spraying chemicals or applying oil mixtures if environmentally acceptable.
- (e) Dust from drilling operations may be controlled by the use of water or chemical dust-control systems integral to the drilling equipment.
- (f) Demolition equipment should be deployed instead of concentrated at one part of a demolition site. This will reduce the intensity of the dust problem around each site.

(2) Asbestos control methods

- (a) All friable asbestos materials used for insulation or fireproofing on any pipe, boiler, tank, reactor, turbine, furnace, or structural member may be removed, either by dismantling in units or sections or by stripping of asbestos materials from the apparatus. This should be done prior to wrecking the structure.
- (b) Asbestos should be adequately wetted during removal to abate asbestos emissions.

- (c) An air-cleaning device employing a fabric filter or wet collectors may be used as an alternative to wetting. The device has been discussed in the *Background Information Document*, developed by the U.S. Environmental Protection Agency (1974).
- (d) Wetting of friable asbestos materials is not desirable when the temperature at the point of stripping is below 32° F, since freezing of oversprayed water may cause serious walking hazards for workers.
- (e) Removal of friable asbestos may not be possible from most unsafe structures prior to wrecking. As such, unsafe structures may be exempted from all asbestos-removal requirements.

#### Noise Control

Noise is a problem at any demolition project, especially when mechanical wrecking methods are employed. Noise cannot normally be eliminated from a demolition activity; it can only be reduced to some extent. The methods of abating noise are given below:

- (1) Warning the local population about explosions or extended noise problems is a good practice. People are less likely to complain when forewarned.
- (2) Heavy concrete or masonry structures may be best demolished by explosives, producing a few large, well-planned noise emissions in lieu of a continuous low-level noise over a much longer period of time.
- (3) All noisy equipment can be muffled; improvements in noise abatement techniques are constantly being developed and refined, and should be experimented with on specific demolition projects.

#### Explosion Products

The choice of suitable explosives can help to avoid the impacts of dangerous smokes on demolition workers. Research is needed to develop explosives that may neutralize explosion products as soon as they are generated.

### Air Pollution from Burning Wastes

Air pollution from burning wastes can be controlled by:

- (1) Stopping all open burning
- (2) Using controlled burning techniques.

### Waste of Resources

Demolition and disposal of solid wastes can lead to waste of resources. The waste can be minimized by:

- (1) Utilizing demolition wastes for productive use
- (2) Rehabilitating old structures
- (3) Building structures with longer life-spans.

### Accidents

Safety considerations are discussed for each demolition technique. Accidents are more frequent on demolition projects, and must be controlled. The control alternative obviously will be the implementation of a well-conceived safety program for each demolition project. Two elements which will assist in the implementation are

- (1) Collection and reporting of accident data so that adequate public concern is generated
- (2) Requirement for adequate compensation for accidents by contractors.

### Controlled Burning with Air Curtain Destructor

Air curtain destructor (ACD) is a technique for controlled burning. The device is employed to burn combustible demolition wastes in a pit below an air curtain. The air curtain prevents the emission of air pollutants to the atmosphere. Figure A-1 shows a typical ACD developed by DriAll, Inc., Attica, Indiana.

The air curtain is useful in: (1) containing smoke and particulate matter below the air screen, (2) providing increased

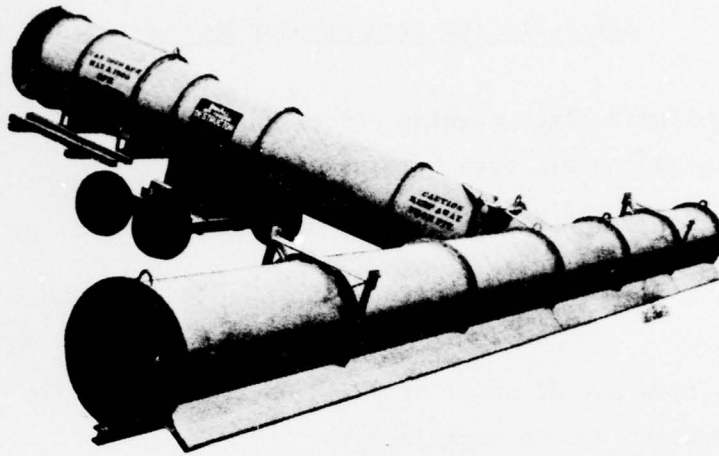

(a) DriAll ACD-42 (pictured without engine)

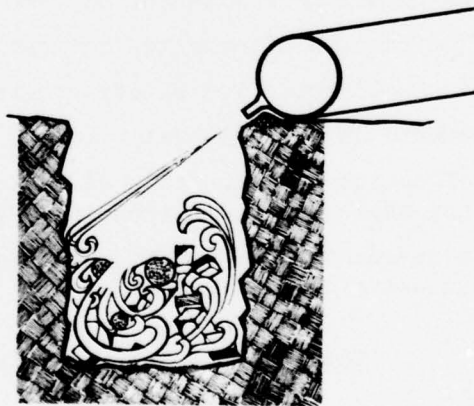

(b) Air Curtain Above Burning Pit

FIGURE A-1. AIR CURTAIN DESTRUCTOR

Source: DriAll, Inc., Attica, Indiana.

combustion efficiency and burning rate, and (3) enhancing combustion temperature to a range of 1600-2000° F.

A variety of models and optional equipment of ACD is available at prices of \$5000 to \$18,000. A demolition contractor usually will own the back-hoe or bulldozer needed to prepare a suitable earth pit. Feeding the waste material to a pit will usually require a bulldozer.

Some demolition contractors operate permanent landfill sites and have constructed permanent pits to appropriate specifications. This increases capital expenditure, but eliminates the need to periodically dig an earth pit. Such an installation would require an additional capital expenditure of \$12,000 to \$20,000, depending on how complex the pit is.

In some areas, soil conditions are such that it is difficult to maintain the vertical pit walls necessary for proper operation of the air curtain. Demolition contractors can purchase surplus or obsolete 40-foot railway box cars, cut the tops off with a torch, and use them as semipermanent pits. Such semipermanent pits have been used in northern California.

Installed operating cost varies with equipment options, such as gas, diesel, or electric motor drive. A large, diesel-powered unit will consume 3 to 4 gallons of fuel per hour. Electric motor driven units will be far less costly to operate. A recent study by DriAll, Inc., shows costs per ton of one type of wood waste consumed to range from \$3 to \$6, including costly rentals of support equipment, provision for lighting and toilet facilities for workers, and use of special devices.

The advantages of using the ACD technique are:

- The equipment is easily portable either with installed running gear and auxiliary wheels or skid-mounted for flat-bed truck transport.
- The operating cost is low since fuel is not required to sustain combustion in the pit. The costs can be lower for the ACD than for landfilling as a method of waste disposal.
- It can effectively handle wood waste having dirt, concrete, oil, nails, plaster, paint, creosote, and combustibles of high moisture content. The waste is reduced to 3 to 10 percent of original volume.

- Generally, there are no significant visible emissions from properly operated ACD units. Usually, they are approved for use in many jurisdictions where open burning is not allowed.

A disadvantage of controlled burning devices such as the ACD is that the heat energy generated during the burning process is wasted. Thus, although (1) a properly operated ACD can provide an acceptable method of waste disposal and (2) many pollution control agencies have issued permits to operate ACD devices, controlled burning of wood wastes is not preferable to burning the wood in refuse-derived, fuel-fired boilers.

## APPENDIX B

DESCRIPTION OF SELECTED DEMOLITION AND  
SALVAGE EQUIPMENT AND METHODSBrick Reclamation System

A used-brick reclamation system has recently been developed by the Quan-Terra Corporation;\* the system can reclaim much of the valuable bricks that were previously thrown away in dumps and landfills. The reclamation system has the following components:

- Dump buckets
- Sorting table
- Dumping table
- Sorting table chutes (pair)
- Conveyor chute
- Palletizing conveyor
- Dust suppressor.

A typical system can reclaim a maximum of 2000 bricks per hour and has a life span of about 3,000,000 processed bricks. The capacity of powered conveyor feed is rated at 1.4 bricks per second or 5000 bricks per hour. Figure B-1 shows the dump bucket, sorting, and dumping table and palleting conveyor.

The dump bucket and the frame adapter are mounted on a terrain forklift. The bucket capacity is adequate for handling 200 to 300 bricks per load, depending on the thickness of mortar and presence of foreign materials. Next to the dump bucket is the dumping table which drops the waste material on the sorting table. A trailer hitch maintains proper position between the sorting table and the conveyor feeding the brick cleaner which is called the palleting conveyor. The conveyor is 10 long, 12 inches wide, and 4 inches thick and has ball-bearing type rollers mounted for rotation clearance. The conveyor is also equipped with a vibrator, primary side guide plate, diversion gate, and a double chute

---

\* Quan-Terra Corporation, 2275 Via Lucia, JaJolla, California.

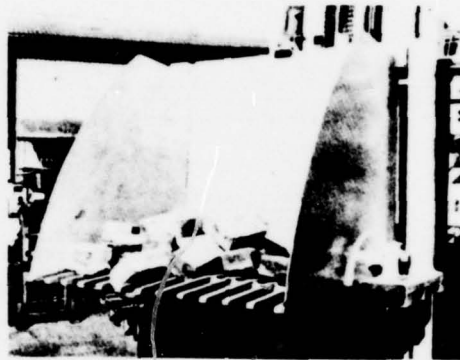

Dump Bucket

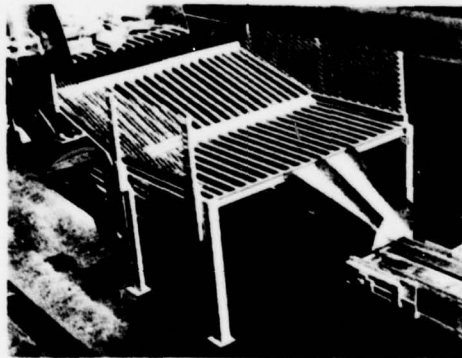

Sorting Table/Dumping Table

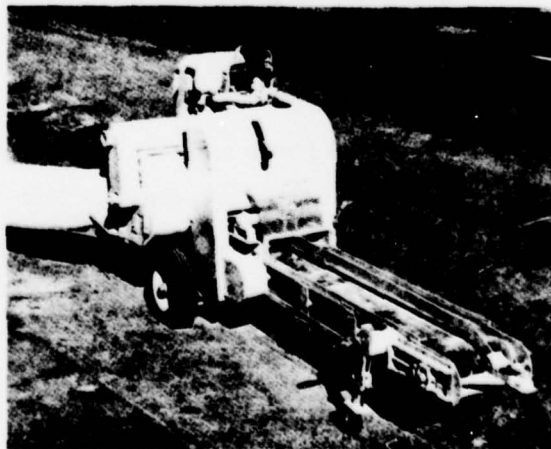

Palleting Conveyor/Dust Suppressor

FIGURE B-1. THE QUAN-TERRA BRICK RECLAMATION SYSTEM

which serves as an effective device for breaking up the mortar on bricks. A dust suppressor 15 feet long with a sealed nylon flair at the end is attached to the palleting conveyor.

The capital cost of the above system has been estimated at \$14,000. The total operating cost is about \$50 per 1000 bricks. However, the firm producing this device has recently been closed and has not responded to requests for revised cost data on this new system.

## APPENDIX C

COMPILATION OF DATA ON SELECTED DEMOLITION PROJECTS

Data from 45 demolition projects were collected with the assistance of several demolition contractors who furnished the data from their files on existing projects. These data, as a function of 13 major project-related parameters, have been compiled and tabulated here. In addition, five estimated parameters introduced for the purpose of data analyses have been calculated for each demolition project. These are presented in Table C-1 under items 14 through 18.

Although the available data are not complete for each parameter listed in Table C-1, they were found adequate for performing the required analyses. The compiled data are presented in Table C-1.

TABLE C-1. DETAILED SUMMARY OF DATA FOR VARIOUS DEMOLITION PROJECTS

Parameters	Columbus #648	Columbus #645	Columbus #639	Columbus #615
(1) Type of structure	Residential Wood	Residential Brick	Residential Brick	Commercial Brick
(2) Total floor area, 1000 sq ft	1.20	0.60	320.00	9.00
(3) Volume of structure, 1000 cu ft	12.00	6.00	3200.00	90.00
(4) Type of demolition	Mechanical	Mechanical	Mechanical	Mechanical
(5) Age of structure, yr				
(6) Average floor height, feet	10.00	10.00	10.00	10.00
(7) Days to wreck	3.00	8.00	34.00	16.00
(8) Total cost of demolition, 1000\$	1.75	2.50		11.75
(9) Distance of disposal site, miles	9.00	5.00	10.00	12.00
(10) Cost of disposal, \$/cu yd <sup>(c)</sup>	1.98	1.68	1.98	2.38
(11) Volume of the truck, cu yd	20.00	20.00	20.00	20.00
(12) Volume of waste, 1000 cu ft	5.40	4.90	560.00	86.50
(13) Composition (by volume)				
Concrete, percent				
Bricks, percent	10.00	80.00	50.00	85.00
Wood, percent	85.00	15.00	45.00	10.00
Paper board, percent	3.00	3.00	3.00	1.00
Steel, percent	2.00	2.00	2.00	4.00
Aluminum, percent				
Plastics, percent				
(14) Volume of waste per sq ft of floor area	4.50	8.17	1.75	9.61
(15) Volume of waste per cu ft of structure	0.45	0.82	0.18	0.96
(16) Adjusted cost of demolition per sq ft of floor area <sup>(c)</sup>	1.45	4.13		1.30
(17) Adjusted cost of demolition per cu ft of structure <sup>(c)</sup>	0.15	0.42		.13
(18) Adjusted cost of disposal, \$/ cu/yd/10 mile <sup>(c)</sup>	2.20	3.37	1.98	1.98

TABLE C-1. (Continued)

Parameters	Columbus #587	Columbus #670	Columbus #675	Columbus #603
(1) Type of structure	Commercial Brick	Commercial Brick	Residential Brick	Residential Wood
(2) Total floor area, 1000 sq ft	9.10	245.00	46.10	1.20
(3) Volume of structure, 1000 cu ft	91.00	2450.00	461.00	12.00
(4) Type of demolition	Mechanical	Mechanical	Mechanical	Mechanical
(5) Age of structure, yr				
(6) Average floor height, feet	10.00	10.00	10.00	10.00
(7) Days to wreck	6.00	8.00	14.00	1.00
(8) Total cost of demolition, 1000\$	4.25	87.50		1.25
(9) Distance of disposal site, miles	8.00	8.00	4.00	10.00
(10) Cost of disposal, \$/cu yd	2.68	1.98	1.68	1.98
(11) Volume of the truck, cu yd	20.00	20.00	20.00	20.00
(12) Volume of waste, 1000 cu ft	17.00	38.00	59.5	10.80
(13) Composition (by volume)				
Concrete, percent				
Bricks, percent	85.00	85.00	80.00	18.00
Wood, percent	10.00	10.00	15.00	80.00
Paper board, percent	1.00	1.00	3.00	--
Steel, percent	4.00	4.00	2.00	2.00
Aluminum, percent				
Plastics, percent				
(14) Volume of waste per sq ft of floor area	1.87	0.16	1.29	9.0
(15) Volume of waste per cu ft of structure	.19	0.02	0.13	0.9
(16) Adjusted cost of demolition per sq ft of floor area <sup>(c)</sup>	0.47	0.40		1.04
(17) Adjusted cost of demolition per cu ft of structure <sup>(c)</sup>	0.05	0.04		0.11
(18) Adjusted cost of disposal, \$/ cu/yd/10 mile <sup>(c)</sup>	3.35	2.48	4.28	1.98

TABLE C-1. (Continued)

Parameters	Columbus #619	Columbus #620	Columbus #630	Columbus #653
(1) Type of structure	Commercial Wood	Commercial Concrete	Residential Brick	Commercial Brick
(2) Total floor area, 1000 sq ft	30.0	120.00	1.40	2.40
(3) Volume of structure, 1000 cu ft	288.00	1200.00	14.00	24.00
(4) Type of demolition	Mechanical	Mechanical	Mechanical	Mechanical
(5) Age of structure, yr				
(6) Average floor height, feet	10.00	10.00	10.00	10.00
(7) Days to wreck	55.00	25.00	10.00	11.00
(8) Total cost of demolition, 1000\$	12.00	57.50	5.00	7.00
(9) Distance of disposal site, miles	10.00	12.00	14.00	11.00
(10) Cost of disposal, \$/cu yd <sup>(c)</sup>	1.98	2.48	2.08	2.08
(11) Volume of the truck, cu yd	20.00		20.00	20.00
(12) Volume of waste, 1000 cu ft	59.00	99.40		
(13) Composition (by volume)				
Concrete, percent		40.00		
Bricks, percent	17.0	35.00	80.00	80.00
Wood, percent	80.0	20.00	15.00	15.00
Paper board, percent		2.00	3.00	3.00
Steel, percent	3.00	3.00	2.00	2.00
Aluminum, percent				
Plastics, percent				
(14) Volume of waste per sq ft of floor area	2.05	0.83	16.98	14.63
(15) Volume of waste per cu ft of structure	0.21	0.09		
(16) Adjusted cost of demolition <sup>(c)</sup> per sq ft of floor area	0.40	0.48	3.54	2.90
(17) Adjusted cost of demolition <sup>(c)</sup> per cu ft of structure	0.04	0.05	0.36	0.30
(18) Adjusted cost <sup>(c)</sup> of disposal, \$/ cu yd/acre	1.98	2.06	1.77	1.90

TABLE C-1. (Continued)

Parameters	Columbus #628	Columbus #624	Columbus #600	Columbus #478
(1) Type of structure	Residential Wood	Residential Wood	Residential Wood	Commercial Brick
(2) Total floor area, 1000 sq ft	2.88	3.20	0.80	5.00
(3) Volume of structure, 1000 cu ft	28.80	32.00	8.00	50.00
(4) Type of demolition	Mechanical	Mechanical	Mechanical	Mechanical
(5) Age of structure, yr				
(6) Average floor height, feet	10.00	10.00	10.00	10.00
(7) Days to wreck	6.00	4.00	2.00	8.00
(8) Total cost of demolition, 1000\$	3.00	2.50	1.50	9.50
(9) Distance of disposal site, miles	15.00	22.00	10.00	11.00
(10) Cost of disposal, \$/cu yd <sup>(c)</sup>	2.97	3.21	1.98	2.08
(11) Volume of the truck, cu yd	20.00	20.00	20.00	20.00
(12) Volume of waste, 1000 cu ft	28.62	27.00	4.86	13.50
(13) Composition (by volume)				
Concrete, percent	7.00	7.00		12.00
Bricks, percent			17.00	53.00
Wood, percent	90.00	90.00	80.00	32.00
Paper board, percent				
Steel, percent	3.00	3.00	3.00	3.00
Aluminum, percent				
Plastics, percent				
(14) Volume of waste per sq ft of floor area	5.00	8.44	6.08	2.7
(15) Volume of waste per cu ft of structure	0.50	0.85	0.61	0.27
(16) Adjusted cost of demolition <sup>(c)</sup> per sq ft of floor area	1.04	0.78	1.86	1.88
(17) Adjusted cost of demolition <sup>(c)</sup> per cu ft of structure	0.19	0.08	0.19	0.19
(18) Adjusted cost of disposal, \$/ cu yd/acre <sup>(c)</sup>	1.98	1.47	1.98	1.89

TABLE C-1. (Continued)

Parameters	Columbus #539	Columbus #551	Columbus #555	Columbus #564
(1) Type of structure	Commercial Wood	Commercial Brick	Commercial Wood	Residential Wood
(2) Total floor area, 1000 sq ft	17.60	12.00		4.32
(3) Volume of structure, 1000 cu ft	211.00	120.00		43.20
(4) Type of demolition	Mechanical	Mechanical	Mechanical	Mechanical
(5) Age of structure, yr				
(6) Average floor height, feet	12.00	10.00		10.00
(7) Days to wreck	64.00	21.00	95.00	6.00
(8) Total cost of demolition, 1000\$	42.50	12.00	140.90	5.00
(9) Distance of disposal site, miles	7.00	12.00	25.00	3.00
(10) Cost of disposal, \$/cu yd <sup>(c)</sup>	2.97	2.48	3.48	1.78
(11) Volume of the truck, cu yd	20.00	20.00	20.00	20.00
(12) Volume of waste, 1000 cu ft		18.90	1437.00	
(13) Composition (by volume)				
Concrete, percent				8.00
Bricks, percent	20.00	85.00	20.00	
Wood, percent	78.00	10.00	77.00	90.00
Paper board, percent		1.00		
Steel, percent	2.00	4.00	3.00	2.00
Aluminum, percent				
Plastics, percent				
(14) Volume of waste per sq ft of floor area	4.00	1.58		13.38
(15) Volume of waste per cu ft of structure	0.40	0.16		
(16) Adjusted cost of demolition, per sq ft of floor area <sup>(c)</sup>	2.40	1.00		1.15
(17) Adjusted cost of demolition, per cu ft of structure <sup>(c)</sup>	0.21	0.10		0.12
(18) Adjusted cost of disposal, \$/ cu/yd/acre <sup>(c)</sup>	4.28	2.06	1.39	5.94

TABLE C-1. (Continued)

Parameters	Columbus #597	Boston #1	Boston #2	Boston #3
(1) Type of structure	Residential Wood	Residential Brick	Commercial Wood	Residential Brick
(2) Total floor area, 1000 sq ft	0.77	39.00	153.50	105.30
(3) Volume of structure, 1000 cu ft	7.70	390.00	1535.00	1053.00
(4) Type of demolition	Mechanical	Mechanical	Mechanical	Mechanical
(5) Age of structure, yr				
(6) Average floor height, feet	10.00			
(7) Days to wreck	4.00			
(8) Total cost of demolition, 1000\$	1.85	37.80	42.00	54.54
(9) Distance of disposal site, miles	25.00			
(10) Cost of disposal, \$/cu yd <sup>(c)</sup>	3.96			
(11) Volume of the truck, cu yd	20.00			
(12) Volume of waste, 1000 cu ft	6.50			
(13) Composition (by volume)				
Concrete, percent	8.00			
Bricks, percent				
Wood, percent	90.00			
Paper board, percent				
Steel, percent	2.00			
Aluminum, percent				
Plastics, percent				
(14) Volume of waste per sq ft of floor area	8.45			
(15) Volume of waste per cu ft of structure	0.85			
(16) Adjusted cost of demolition, per sq ft of floor area <sup>(c)</sup>	2.39	0.94	0.28	0.51
(17) Adjusted cost of demolition, per cu ft of structure <sup>(c)</sup>	0.24	0.10	0.03	0.06
(18) Adjusted of disposal, \$/ cu yd/acre <sup>(c)</sup>	1.58			

TABLE C-1. (Continued)

Parameters	Chicago #1	Chicago #2	Chicago #3	Chicago #4
(1) Type of structure	Residential Wood	Residential Wood	Residential Wood	Commercial Wood
(2) Total floor area, 1000 sq ft	13.20	2.20	13.74	22.00
(3) Volume of structure, 1000 cu ft	132.00	33.00	200.00	440.00
(4) Type of demolition	Mechanical	Mechanical	Mechanical	Mechanical
(5) Age of structure, yr		50.00		65.00
(6) Average floor height, feet	10.00	15.00	15.00	20.00
(7) Days to wreck	15.00	4.00	12.00	17.00
(8) Total cost of demolition, 1000\$	6.94	2.45	7.00	26.00
(9) Distance of disposal site, miles	10.00	15.00	20.00	15.00
(10) Cost <sub>(c)</sub> of disposal, \$/cu yd	1.30	1.66	2.53	2.24
(11) Volume of the truck, cu yd	55.00	55.00	55.00	55.00
(12) Volume of waste, 1000 cu ft	75.60	11.00	35.00	128.00
(13) Composition (by volume)				
Concrete, percent	8.00			20.00
Bricks, percent	28.00	8.00	25.00	17.00
Wood, percent	62.00	90.00	73.00	60.00
Paper board, percent				
Steel, percent	2.00 <sup>(a)</sup>	2.00	2.00	3.00
Aluminum, percent				
Plastics, percent				
(14) Volume of waste per sq ft of floor area	5.73	5.00	2.55	5.82
(15) Volume of waste per cu ft of structure	0.58	0.34	0.18	0.30
(16) Adjusted cost of demolition <sub>(c)</sub> per sq ft of floor area	0.51	1.07	0.49	1.14
(17) Adjusted cost of demolition <sub>(c)</sub> per cu ft of structure	0.06	0.08	0.04	0.06
(18) Adjusted cost <sub>(c)</sub> of disposal, \$/cu yd/acre	1.30	1.11	1.27	1.50

TABLE C-1. (Continued)

Parameters	Chicago #5	Detroit #1	Detroit #2	Detroit #3
(1) Type of structure	Commercial Concrete	Residential Wood	Residential Wood	Residential Wood
(2) Total floor area, 1000 sq ft	33.00	1.50	1.50	2.00
(3) Volume of structure, 1000 cu ft	660.00	22.50	22.50	24.00
(4) Type of demolition	Mechanical	Mechanical	Mechanical	Mechanical
(5) Age of structure, yr	70.00	55.00	55.00	60.00
(6) Average floor height, feet	20.00	15.00	15.00	12.00
(7) Days to wreck	25.00			
(8) Total cost of demolition, 1000\$	39.60	1.20	1.08	1.60
(9) Distance of disposal site, miles	10.00	35.00	15.00	35.00
(10) Cost of disposal, \$/cu yd <sup>(c)</sup>	2.24	4.82	3.51	4.82
(11) Volume of the truck, cu yd	55.00	55.00	35.00	55.00
(12) Volume of waste, 1000 cu ft	188.00	2.84	2.84	5.4
(13) Composition (by volume)				
Concrete, percent	59.00			
Bricks, percent	30.00	17.00	17.00	5.00
Wood, percent	7.00	80.00	80.00	94.00
Paper board, percent				
Steel, percent	3.00	4.00	3.00	3.00
Aluminum, percent				
Plastics, percent				
(14) Volume of waste per sq ft of floor area	5.70	1.90	1.90	2.70
(15) Volume of waste per cu ft of structure	0.29	0.13	0.13	0.23
(16) Adjusted cost of demolition, per sq ft of floor area <sup>(c)</sup>	1.15	0.70	0.63	0.70
(17) Adjusted cost of demolition, per cu ft of structure <sup>(c)</sup>	0.06	0.05	0.04	0.06
(18) Adjusted cost of disposal, \$/ cu yd/acre <sup>(c)</sup>	2.24	1.40	2.34	1.40

TABLE C-1. (Continued)

Parameters	Detroit #4	Detroit #5	Detroit #6	Detroit #7
(1) Type of structure	Residential Wood	Residential Wood	Residential Wood	Residential Wood
(2) Total floor area, 1000 sq ft	3.60	5.04	33.60	16.80
(3) Volume of structure, 1000 cu ft	43.20	60.50	403.20	201.60
(4) Type of demolition	Mechanical	Mechanical	Mechanical	Mechanical
(5) Age of structure, yr	65.00	70.00	65.00	65.00
(6) Average floor height, feet	12.00	12.00	12.00	12.00
(7) Days to wreck				
(8) Total cost of demolition, 1000\$	2.00	6.66	46.00	26.20
(9) Distance of disposal site, miles	20.00	30.00	5.00	7.00
(10) Cost of disposal, \$/cu yd <sup>(c)</sup>	1.88	1.75	0.88	1.07
(11) Volume of the truck, cu yd	55.00	55.00	55.00	55.00
(12) Volume of waste, 1000 cu ft	9.70	13.50	282.00	195.30
(13) Composition (by volume)				
Concrete, percent	2.00	2.00	10.00	10.00
Bricks, percent	15.00	15.00	20.00	10.00
Wood, percent	75.00	75.00	67.00	77.00
Paper board, percent				
Steel, percent	3.00	3.00	3.00	3.00
Aluminum, percent	5.00	5.00		
Plastics, percent				
(14) Volume of waste per sq ft of floor area	2.70	2.68	8.40	11.63
(15) Volume of waste per cu ft of structure	0.23	0.23	0.01	0.97
(16) Adjusted cost of demolition, per sq ft of floor area <sup>(c)</sup>	0.50	1.09	1.21	1.37
(17) Adjusted cost of demolition, per cu ft of structure <sup>(c)</sup>	0.04	0.19	0.19	0.12
(18) Adjusted cost of disposal, \$/cu yd/acre <sup>(c)</sup>	0.95	0.60	1.76	1.52

TABLE C-1. (Continued)

Parameters	Detroit #8	New York #1	New York #2	New York #3
(1) Type of structure	Residential Wood	Commercial Multi-story Brick	Commercial Multi-story Brick	Commercial Multi-story Brick
(2) Total floor area, 1000 sq ft	57.60	105.80	21.22	644.00
(3) Volume of structure, 1000 cu ft	691.20	1370.10	290.00	9960.00
(4) Type of demolition	Mechanical	Manual/ Mechanical	Manual/ Mechanical	Manual/ Mechanical
(5) Age of structure, yr	60.00	85.00	85.00	
(6) Average floor height, feet	12.00	12.95	13.60	10.90
(7) Days to wreck		45.00	30.00	120.0
(8) Total cost of demolition, 1000\$	89.83	405.00	84.00	1686.00
(9) Distance of disposal site, miles	10.00	12.00 (offshore)	12.00 (offshore)	10.00
(10) Cost of disposal, \$/cu yd	1.53	3.88	3.88	3.87
(11) Volume of the truck, cu yd	55.00	35.00	35.00	35.00
(12) Volume of waste, 1000 cu ft	393.87	334.84	99.43	1642.00
(13) Composition (by volume)				
Concrete, percent	10.00	38.00	37.00	35.00
Bricks, percent	20.00	57.00	56.00	52.00
Wood, percent	67.00	3.00	6.00	10.00
Paper board, percent				
Steel, percent	3.00	2.00	1.00	3.00
Aluminum, percent				
Plastics, percent				
(14) Volume of waste per sq ft of floor area	6.80	3.17	4.69	2.55
(15) Volume of waste per cu ft of structure	0.58	0.25	0.35	0.17
(16) Adjusted cost of demolition <sup>(c)</sup> per sq ft of floor area	1.37	3.14	3.24	2.15
(17) Adjusted cost of demolition <sup>(c)</sup> per cu ft of structure				
(18) Adjusted cost of disposal, \$/ cu yd/acre <sup>(c)</sup>	1.53	3.24	3.24	3.87

TABLE C-1. (Continued)

Parameters	Oklahoma City #1	Dover AFB #1	Fort Carson #1
(1) Type of structure	Commercial Concrete	Commercial Concrete	Residential Wood
(2) Total floor area, 1000 sq ft	36.00	150.00	50.00
(3) Volume of structure, 1000 cu ft	432.00	1650.00	
(4) Type of demolition	Explosive	Mechanical	Mechanical
(5) Age of structure, yr	75.00	70.00	
(6) Average floor height, feet	12.00	11.00	
(7) Days to wreck	35.00	100.00	
(8) Total cost of demolition, 1000\$	100.00	125.00	25.00 <sup>(b)</sup>
(9) Distance of disposal site, miles	20.00	20.00	
(10) Cost of disposal, \$/cu yd <sup>(c)</sup>	3.30	5.75	
(11) Volume of the truck, cu yd	35.00	35.00	
(12) Volume of waste, 1000 cu ft	108.00	71.10	
(13) Composition (by volume)			
Concrete, percent	50.00	45.00	
Bricks, percent	20.00	16.00	
Wood, percent	20.00	27.00	
Paper board, percent	7.00	7.00	
Steel, percent	3.00	2.00	
Aluminum, percent			
Asphalt, percent		3.00	
(14) Volume of waste per sq ft of floor area	3.00	0.05	
(15) Volume of waste per cu ft of structure	0.25	0.05	
(16) Adjusted cost of demolition <sup>(c)</sup> per sq ft of floor area	3.68	.98	0.58
(17) Adjusted cost of demolition <sup>(c)</sup> per cu ft of structure	0.32	0.09	
(18) Adjusted cost <sup>(c)</sup> of disposal, \$/ cu yd/acre	1.65	2.88	

TABLE C-1. (Continued)

Parameters	Fort Carson #2	Presidio of Monterey
(1) Type of structure	Residential Wood	Residential Wood
(2) Total floor area, 1000 sq ft	252.60	25.35
(3) Volume of structure, 1000 cu ft		
(4) Type of demolition	Mechanical	Mechanical
(5) Age of structure, yr		
(6) Average floor height, feet		
(7) Days to wreck		
(8) Total cost of demolition, 1000\$	117.00 <sup>(b)</sup>	23.00
(9) Distance of disposal site, miles		
(10) Adjusted cost of disposal, \$/cu yd		
(11) Volume of the truck, cu yd		
(12) Volume of waste, 1000 cu ft		
(13) Composition (by volume)		
Concrete, percent		
Bricks, percent		
Wood, percent		
Paper board, percent		
Steel, percent		
Aluminum, percent		
Plastics, percent		
(14) Volume of waste per sq ft of floor area		
(15) Volume of waste per cu ft of structure		
(16) Adjusted cost of demolition, per sq ft of floor area <sup>(c)</sup>	0.59	0.76
(17) Total cost of demolition per cu ft of structure		
(18) Cost of disposal, \$/cu yd/ acre		

TABLE C-1. (Continued)

Footnotes to Table C-1

- (a) Includes 19.5 tons of steel, 7.5 tons of iron, 0.4 ton of brass, 0.11 ton of copper, 0.07 ton of insulated wire.
- (b) At Fort Carson, the demolition cost also includes the cost of foundation removal. Foundation removal cost is about 52 percent for Project #1 and 66 percent for Project #2.
- (c) These costs are adjusted to the December 1974 U.S. average prices, using the ENR Construction Cost Indices.

## APPENDIX D

COMPILATION OF DATA ON SELECTED CONSTRUCTION PROJECTS

In conformity with the overall scope of the present CERL task, the emphasis placed on analysis of construction data was less in comparison with the effort expended on collection and correlation of demolition waste data. Also, an earlier study by Battelle ("Predictive Criteria for Construction/Demolition Solid Waste Management", CERL Technical Report N-14, 1976) for CERL had already covered the construction waste aspects in greater detail. In the present study, construction waste data defining the characteristics and waste disposal aspects were analyzed for 14 projects. These include: (1) six civilian construction sites in the Columbus, Ohio, and Detroit, Michigan, areas and (2) eight military structures located on Fort Hood, Texas, and Fort Campbell, Kentucky.\* At the four Army posts visited for demolition data (see Appendix C), no construction solid wastes data were available. In this report, the majority of the construction projects studied are residential structures. In addition, there are two gymnasiums, one commercial structure, and two airfields.

The data collected on these construction projects are presented in Table D-1. The parameters, (1) to (9), shown in the table relate to the construction project characteristics such as waste volume generated, composition, and cost of disposal. These parameters also represent the raw data collected from the project site or from the files of the contractors. Parameters (10) and (11) are estimated from raw data.

For instance, the parameter (10), adjusted disposal cost, was calculated according to the following equation.

$$\text{Adjusted disposal cost} = \frac{10 \text{ [Cost of waste disposal (\$/cu yd)]}}{(\$/\text{cu yd}/10 \text{ mile}) \quad \text{Distance of disposal site (miles)},$$

where the cost of waste disposal and distance of disposal site are both given data.

Similarly, parameter (11), waste volume per unit area of structure, is derived from raw data as follows:

\* These military projects are from CERL Technical Report N-14.

$$\text{Waste volume per unit area} = \frac{\text{Volume of total waste}}{\text{Total floor area}} = \frac{\text{cu yd of waste}}{\text{acres}} .$$

These data are also summarized in Table D-1.

TABLE D-1. SUMMARY OF DATA FOR CONSTRUCTION PROJECTS

Parameters	Project Location				
	Columbus #1	Columbus #2	Columbus #3	Columbus #4	Columbus #5
(1) Type of structure constructed	Residential	Residential	Residential	Residential	Residential
(2) Type of construction	Wood frame	Wood frame	Wood frame	Wood frame	Wood frame
(3) Total floor area, (a) acres	0.275	0.441	0.117	0.939	0.914
(4) Duration of construction, months	3.00	3.00	6.0	6.0	6.0
(5) Volume of solid waste, (b) cu yd	125	202.00	55	441	431
(6) Composition of solid waste, percent by vol					
Concrete	5.00	5.00	5.00	5.00	5.00
Bricks	20.00	20.00	14.00	14.00	14.00
Wood	65.00	65.00	68.00	68.00	68.00
Paper board	8.00	8.00	11.50	11.50	11.50
Scrap iron	1.00	1.00	1.50	1.50	1.50
Scrap aluminum	1.00	1.00			
(7) Cost of the structure in 1000\$	420	540	224	1518	1332
(8) Cost of waste disposal, \$/cu yd	7.61	4.75	2.97	2.97	2.97
(9) Distance of disposal site, miles	15	15	12	12	12
(10) Adjusted disposal cost, \$/cu yd/10 mile* <sup>(c)</sup>	5.08	3.17	2.48	2.48	2.48
(11) Volume of waste, cu yd/acre floor area*	453	459	470	469	471

\* These are derived parameters.

TABLE D-1. (Continued)

Parameters	Project Location			
	Fort Hood #1	Fort Hood #2	Fort Hood #3	Fort Hood #4
(1) Type of structure constructed	Gymnasium	Residential	Commercial	Residential
(2) Type of construction	Concrete	Concrete	Concrete	Concrete/wood
(3) Total floor area, (a) acres	1.40	18.70	3.000	30.000
(4) Duration of construction, months	14.0	3.30	2.00	12.00
(5) Volume of solid waste, (b) cu yd	2,718	8,750	1,400	11,860
(6) Composition of solid waste, percent by vol				
Concrete	64.00	67.00	67.00	67.00
Bricks		10.00	8.00	10.00
Wood	19.00	10.00	10.00	13.00
Paper board	10.00	10.00	10.00	7.00
Scrap iron	7.00	3.00	3.00	3.00
Scrap aluminum			2.00	
(7) Cost of the structure in 1000\$	2,200	24,300	4,100	19,500
(8) Cost of waste disposal, \$/cu yd <sup>(c)</sup>	8.17	5.25	4.95	4.95
(9) Distance of disposal site, miles	12	12	12	12
(10) Adjusted disposal cost, \$/cu yd/10 mile <sup>(c)</sup>	6.81	4.38	4.12	4.12
(11) Volume of waste, cu yd/acre	1,941	468	467	395

TABLE D-1. (Continued)

Project Location Parameters	Fort Campbell #1	Fort Campbell #2	Fort Campbell #3	Fort Campbell #4	Detroit #1
(1) Type of structure constructed	Residential	Residential	Gymnasium	Airfield	Airfield
(2) Type of construction	Concrete/wood	Remodeling	Concrete/steel	Concrete	Concrete
(3) Total floor area, (a) acres	0.900	25.000	1.00	4.00	10.00
(4) Duration of construction, months	11.00	16.00	11.00	8.00	24.00
(5) Volume of solid waste, (b) cu yd	419	7,500	2,000	220	650
(6) Composition of solid waste, percent by vol					
Concrete	45.00	22.00	60.00	100.00	100.00
Bricks		8.00			
Wood	45.00	60.00	10.00		
Paper board	7.00	7.00	20.00		
Scrap iron	3.00	3.00	10.00		
Scrap aluminum					
(7) Cost of the structure in 1000\$	1,800	12,100	1,300	6,500	15,000
(8) Cost of waste disposal, \$/cu yd	8.42	7.43	7.43	7.43	2.97
(9) Distance of disposal site, miles	13	13	13	13	9
(10) Adjusted disposal cost, \$/cu yd/10 mile	6.48	5.71	5.71	5.71	3.32
(11) Volume of waste, cu yd/acre	465	300	2,000	55	65

Footnotes to Table D-1

- (a) The floor area is expressed in acres; 1 acre is equivalent to 43,560 square feet.
- (b) On an average, construction waste weighs 0.5 ton per cubic yard.
- (c) All costs are adjusted to the December 1974 U.S. average prices, using the ENR Construction Cost Indices.

## APPENDIX E

LIST OF CONTACTS AND DATA SOURCES

Many different organizations and/or experts were contacted for obtaining data relating to construction and demolition projects. Also contacted were a few equipment manufacturers and waste reclaimers to collect information relating to demolition technology and/or waste reclamation. The various data sources, their addresses, phone numbers, and type of data furnished are listed in this appendix.

<u>Organization Contacted</u>	<u>Type of Data Furnished</u>
(1) Adamo Wrecking Co. Detroit, Michigan John Adamo (313) 372-4033	Demolition data
(2) Angelo Tafrate Co. 28273 Grosebeck Highway Roseville, Michigan 48066 Dominic Tafrate (313) 571-1000	Brick salvage
(3) Associated General Contractors of America 1957 E Street, N.W. Washington, D.C. 20006 Jeffrey M. Cross (202) 393-2040 Joseph Ashooh (202) 393-2040	Construction data
(4) Brandenburg Demolition 2110 S. Marshall Blvd. Chicago, Illinois 60623 (312) 521-3800	Demolition waste data
(5) City of Columbus Division of Sanitation 423 Short Street Columbus, Ohio Richard Harris, Suptd. Tom Horan, Admin. Analyst (614) 461-8250	Demolition data
(6) City of Columbus Development Division Urban Renewal Section City Hall Columbus, Ohio Jack Colwell (614) 461-5795	Demolition data

<u>Organization Contacted</u>	<u>Type of Data Furnished</u>
(7) City of Columbus Division of Building Regulation City Hall Columbus, Ohio George K. Hodge (614) 461-7433	Demolition data
(8) City of Detroit Dept. of Urban Renewal 350 E. Congress Street Detroit, Michigan 48226 George D. Nichols (313) 224-2370	Demolition data
(9) Cleveland Wrecking Co. 1400 Harrison Street Cincinnati, Ohio Marvin H. Rose (513) 921-1160	Demolition data
(10) Department of Sanitation 125 Worth Street New York, New York Robert Groh, Commissioner (212) 566-2734	Demolition wastes
(11) Department of Sanitation New York, New York Arthur Price Head of Waste Disposal (212) 566-3847	Construction and demolition wastes
(12) DriAll, Inc. Box 309, W.S. Attica, Indiana 47918	Demolition technology
(13) Duane Corporation 41 Hallet Street Dorchester, Massachusetts Herbert Duane (617) 436-7260	Demolition technology
(14) EJT Construction Company 104 North Saulsbury Road Dover, Delaware 19901 (302) 674-0700	Demolition data
(15) Emaco 111 Van Riper Avenue Elmwood Park, New Jersey 07407	Demolition technology
(16) Experimental Excavation Research Laboratory Laurence Livermoor Labs Livermoor, California 94550 Capt. W. Harvey (415) 447-7651	Blasting technology

<u>Organization Contacted</u>	<u>Type of Data Furnished</u>
(17) Federal Wrecking Co. Detroit, Michigan Dan Welber (313) 843-3320	Demolition data
(18) Fort Belvoir Demolition School Ft. Belvoir, Virginia Lt. Col. Fawcette (703) 664-3008 Roger Neely (703) 664-2515	Demolition data
(19) Fort Carson, Colorado 80913 Donald L. Starr Resident Engineer (303) 597-0420	Demolition data
(20) Fort Myer, D.C. MAJ Charles Solliday Resident Engineer (202) 692-2956	Demolition data
(21) G. C. O'Brien, Inc. 2-21 54th Avenue Long Island, New York 11101 Helen M. O'Brien VeeKay Tejpaul (212) 784-2218	Demolition data
(22) Granite Construction Co. Post Office Box 287 Monterey, California 93940 John Douglas (408) 394-1433	Demolition data
(23) Home Builder's Association of Central Ohio 5898 Cleveland Avenue Columbus, Ohio 43229 Robert Stutz Technical Director (614) 891-0575	Construction data
(24) Housing Department 513 City-County Building Detroit, Michigan 48226 Silas Estes Chief, Housing Department (313) 224-3244 Gerald Sands (313) 224-3240	Demolition data

<u>Organization Contacted</u>	<u>Type of Data Furnished</u>
(25) John Deere Sales & Service Valley Equipment Co. 2549 Stanley Avenue Dayton, Ohio 45404 John Faulkner (513) 224-0572	Demolition equipment
(26) Julian C. Cohen Co. 5000 Windom Road Blandensburg, Maryland (202) 277-4444	Demolition and salvage data
(27) Kent Air Tool Co. 711 Lake Street Kent, Ohio 44240 Robert Burns Chief Engineer (216) 673-5826	Demolition hammer
(28) LEB, Inc. 2525 Blandenburg Road, N.E. Washington, D.C. 20018 Leroy Beckford (202) 526-6119	Demolition data
(29) Macy's, Inc. Detroit, Michigan James Jenkins (313) 894-2000	Demolition data
(30) Marks Tractor Columbus, Ohio Tom Rhattigan (614) 443-9464	Demolition hammer
(31) National Association of Demolition Contractors 4415 West Harrison Street Hillside, Illinois 60162 Bill Baker (312) 449-5959	Brick recycling
(32) National Association of Home Builders 15th & M Streets, N.W. Washington, D.C. 20005 Bob Enzel (202) 452-0438 Betty Conn (202) 452-0436 Sumichrast (202) 452-0200	Construction data

<u>Organization Contacted</u>	<u>Type of Data Furnished</u>
(33) National Association of Home Builders Research Labs Post Office Box 1627 Rockville, Maryland 20850 Ralph Johnson Lee Fisher (301) 762-4200	Construction data
(34) National Wrecking Co. 1231 West 42nd Street Chicago, Illinois 60609 Sheldon Mandell Norman Mandell (312) 376-7500	Demolition data
(35) Ohio Environmental Protection Agency Division of Solid Waste Management Columbus, Ohio Dave Lenerdz (614) 466-8934	Landfill permit info
(36) Picatinny Arsenal Dover, New Jersey Joe Severini	Demolition data
(37) Progress Wrecking Co. Detroit, Michigan Peter Schantz (313) 964-4747	Demolition data
(38) Quan-Terra Corp. 2275 Via Lucia La Jolla, California 92037 (714) 459-8457	Brick reclaiming system
(39) Russell-Leaford Co. 8215A Fentom Street Silver Spring, Maryland 20910 (301) 565-5100	Demolition data
(40) Ryan Homes, Inc. 33 E. North Street Worthington, Ohio 43085 Jim Bagley (614) 885-3401	Construction data
(41) S. G. Loewendick & Sons, Inc. 1890 E. Main Street Columbus, Ohio S. G. Loewendick (614) 253-8601	Demolition data

<u>Organization Contacted</u>	<u>Type of Data Furnished</u>
(42) Somers Construction Co., Inc. Union Avenue & Cynwyd Road Bala Cynwyd, Pennsylvania 19004 (215) 839-6760	Demolition data
(43) United Road Machinery Co. Box 4141 Memphis, Tennessee 38104	Demolition technology
(44) U.S. Army Engineer Waterways Experiment Station Weapons Effects Laboratory Vicksburg, Mississippi 39180 F. W. Skinner (601) 636-3111	Demolition technology
(45) Wallick Construction Co. 150 E. Mound Street Columbus, Ohio John Williams (614) 464-4640 Ken Smith (614) 891-0037	Construction data
(46) Wayne County Road Commission 415 Clifford Detroit, Michigan 48226 Robert Larson (313) 962-5700	Airport data
(47) Winchester Services, Inc. 2124 Greccourt Street Toledo, Ohio 43615 John Kohler (419) 666-4230	Demolition technology

