

CRREL

REPORT 76-40



Photomacrography of artifacts in transparent materials

13

ADA033670

DDIC
RECEIVED
DEC 9 1976
Gr

DISTRIBUTION STATEMENT A
Approved for public release;
Distribution Unlimited



Cover: Spider-web artifact induced by laser radiation into a 0.5-cm-thick distilled H₂O ice sample frozen onto a concrete substrate. (Photograph by Stephen J. Marshall.)

CRREL Report 76-40

Photomacrography of artifacts in transparent materials

Stephen J. Marshall

November 1976

ACCESSION for		
NTIS	White Section	<input checked="" type="checkbox"/>
DIC	Buff Section	<input type="checkbox"/>
UNANNOUNCED IDENTIFICATION		
BY		
DISTRIBUTION/AVAILABILITY CODES		
Dist.	Avail. and/or	SPECIAL
A		

Prepared for

U.S. ARMY MATERIEL COMMAND

By

CORPS OF ENGINEERS, U.S. ARMY

COLD REGIONS RESEARCH AND ENGINEERING LABORATORY

HANOVER, NEW HAMPSHIRE

Unclassified

SECURITY CLASSIFICATION OF THIS PAGE (When Data Entered)

REPORT DOCUMENTATION PAGE

READ INSTRUCTIONS BEFORE COMPLETING FORM

1. REPORT NUMBER CRREL Report-76-40	2. GOVT ACCESSION NO.	3. RECIPIENT'S CATALOG NUMBER
4. TITLE (and Subtitle) PHOTOMACROGRAPHY OF ARTIFACTS IN TRANSPARENT MATERIALS,	5. TYPE OF REPORT & PERIOD COVERED	
	6. PERFORMING ORG. REPORT NUMBER	
7. AUTHOR(s) Stephen J. Marshall	8. CONTRACT OR GRANT NUMBER(s)	
9. PERFORMING ORGANIZATION NAME AND ADDRESS U.S. Army Cold Regions Research and Engineering Laboratory Hanover, New Hampshire 03755	10. PROGRAM ELEMENT, PROJECT, TASK AREA & WORK UNIT NUMBERS DA 1F161102B52A Task 02, Work Unit 002	
11. CONTROLLING OFFICE NAME AND ADDRESS U.S. Army Materiel Command Alexandria, Virginia 22034	12. REPORT DATE November 1976	
14. MONITORING AGENCY NAME & ADDRESS (if different from Controlling Office) 12 38p.	13. NUMBER OF PAGES 36	15. SECURITY CLASS. (of this report) Unclassified
15a. DECLASSIFICATION/DOWNGRADING SCHEDULE		
16. DISTRIBUTION STATEMENT (of this Report) Approved for public release; distribution unlimited.		
17. DISTRIBUTION STATEMENT (of the abstract entered in Block 20, if different from Report)		
18. SUPPLEMENTARY NOTES		
19. KEY WORDS (Continue on reverse side if necessary and identify by block number) Ice Microscopy Photomacrography Transparency		
20. ABSTRACT (Continue on reverse side if necessary and identify by block number) Several original methods were developed to photograph artifacts in transparent materials such as ice. The artifacts, occurring in the surface, bulk, and interface, were generally 0.01 mm to 70 mm in size. Sample preparation, illumination, focusing and other technical problems are discussed in detail. Several sample photographs are included.		

037 100 AB

PREFACE

This report was prepared by Stephen J. Marshall, Physical Science Technician, of the Physical Sciences Branch, Research Division, U.S. Army Cold Regions Research and Engineering Laboratory. The research was funded by DA Project 1F161102B52A, *Mobility and Environmental Research*, Task 02, *Military Aspects of Cold Regions Research*, Work Unit 002, *Adhesion and Physics of Ice*.

The manuscript was technically reviewed by Dr. Anthony J. Gow and Roger H. Berger. Also, the author wishes to acknowledge the help of CPT Jean W. Lane, who rendered valuable advice and assistance.

The contents of this report are not to be used for advertising or promotional purposes. Citation of trade names does not constitute an official endorsement or approval of the use of such commercial products.

CONTENTS

	Page
Abstract	i
Preface	ii
Summary.....	v
Introduction	1
Equipment	2
The microscope system	2
The camera system	2
Tools for preparation of sample	5
Laboratory procedure	10
Categorizing artifact	10
Choosing setup	10
Preparing sample	11
Illuminating sample	12
Photographing artifact	13
Results	17
Literature cited	23
Selected bibliography	24
Appendix. Reference information for photomacrographic and photo- micrographic applications	25

ILLUSTRATIONS

Figure

1. A typical transmitted and incident light microscope	3
2. The microscope-camera system used	4
3. Illumination system used	6
4. Polaroid film holder	7
5. Tools useful for preparing ice surfaces	8
6. Microscope stage replaced by universal joint or bracket	9
7. Attachable mechanical stage traversing area 40x20 mm	9
8. Four configurations of the photographic system	12
9. Transmitted, reflected, and scattered beams	13
10. A practical camera setup for photographing artifacts in ice	13
11. A practical transmitted light setup for photographing artifacts in ice	14
12. A practical incident light setup for photographing artifacts in ice	14
13. Photograph of a Bausch and Lomb glass calibration slide	18
14. Photograph of artifact damage in Lucite	19
15. Photographs of damage sites in ice	20

TABLES

Table	Page
I. Mirror polishing abrasives listed from coarse to fine	8
II. Checklist for laboratory procedure.....	10
III. Available 35-mm Kodak films	15

SUMMARY

One of the problems encountered while pursuing a study of artifacts induced by a laser beam in ice was the requirement for photographs of the artifacts (see cover). These artifacts occurred on the surface and in the bulk of a highly reflective, transparent material (ice) not ideally suited to conventional photographic methods. In addition, these artifacts were predominantly in the difficult photomacrographic range of magnification (0.1 mm to 70 mm), with some larger or smaller artifacts (i.e. in the close-up and photomicrographic ranges) further compounding the problem. It was found that special procedures had to be devised in order to achieve satisfactory results, and that there was little information available in the literature to serve as a guide.

This report provides a discussion of the problems encountered, a detailed presentation of the techniques used, a checklist designed to guide the technician, suggestions on modifications of equipment, and several photographs as examples of the kind of results to be expected. A tabulation of pertinent data is also included as a convenience to the reader.

Sample preparation techniques are discussed with emphasis on achieving an optically clear surface (or window) through which bulk artifacts can be viewed. Illumination and sample orientation are discussed in an attempt to clarify and simplify much of the discussion in the literature.

PHOTOMACROGRAPHY OF ARTIFACTS IN TRANSPARENT MATERIALS

Stephen J. Marshall

INTRODUCTION

For scientific purposes, photography may be classified by *magnification*. If d_o is a given distance between two points in an object and d_i the distance between the same points in the photographic image of the object, the magnification M of the photograph is

$$M = d_i/d_o. \quad (1)$$

If M is a fraction or unity, the photographic technique required is known as "close-up photography"; if M is greater than unity but less than or equal to 50, the photographic technique required is "photomacrography"; for values of M greater than 50, the required technique is "photomicrography."

This report will be concerned primarily with photomacrography, which limits the discussion to objects in the size range of 0.01 mm to 70 mm. The lower limit is determined by the maximum magnification, 50X, and the resolution of the eye. The upper limit is fixed by the field of view of readily available cameras, e.g. a 35-mm camera or a camera incorporated into an optical microscope (see Appendix).

For the purposes of this work, a transparent material is defined as one for which the transmission of electromagnetic waves at optical frequencies and ordinary intensities is greater than 99%. Examples are NaCl, glass, and ice. It is well-known that optical beams of extraordinary intensities (such as those produced by high-powered lasers) will damage such materials and thereby introduce artifacts.² The study of these artifacts has recently become important in the development of materials for use in optical systems associated with lasers.⁴

The study of fractures in transparent materials also involves the study of structural artifacts in these materials.⁹ These studies often require photographs of the artifacts in question, and most such artifacts fall into the size range of interest in this work.¹⁰

Both the particular size range and the type of material pose special problems for the photographer interested in artifacts in transparent materials. As can be seen from the information in the Appendix, it is difficult to assemble a photomacrographic system with appropriate magnifications and field of view because most available microscopes are designed for the microscopic range. Transparent materials often have highly reflective surfaces and their artifacts show little contrast to the transparent matrix. These surface reflections are known as "catchlights" to close-up photographers and "pointlights" to photomacrographers.

For artifacts embedded in the bulk of the matrix, the photographic system must be capable of focusing into the bulk while maintaining sufficient depth of field. Depth of field is normally not too critical in the macroscopic examination of thin sections in transmitted light. However, when ice samples greater than 25 mm thick exhibit artifacts in the bulk that have a shape such that 25% or more of their length is in the direction of observation, depth of field then becomes a problem beyond the capability of standard commercial setups without modification (again, see Appendix). Such a situation requires, in effect, macro-examination of thick sections, and any perusal of the literature will show that many of the artifacts of interest in transparent materials pose depth of field problems.

Contrast, specular reflection, magnification, field of view, and depth of field must all be considered for photography of optically transparent materials at magnifications of 1 to 50. This report presents some solutions for common photomacrographic problems caused by these factors.

EQUIPMENT

The microscope system

In this report, the Leitz-Wetzlar Ortholux Microscope fitted with the Aristophot photographic apparatus is used as an example of a system for covering the 1 to 50X range. In particular, it covers the very difficult range of 0.2 to 1X, which will be discussed further below.

The Ortholux System (Fig. 1) coupled with the Aristophot Universal Photographic System (Fig. 2) provides a choice from a wide range of illumination options. These options include lightfield and dark-field photography using both transmitted and incident light, as well as phase contrast work. Many light sources can be used with this system, including halide illumination, which produces a more intense light beam to improve image brightness and sharpness and makes Normal'ski³ microscopy possible.

The Leitz-Wetzlar Ultropak Incident Light Illuminator (Fig. 3a) was primarily used in this study. This illuminator allows incident lighting of a sample with a vertically adjustable ring condenser that surrounds the objective lens concentrically and guides the light to the object. Layers of the specimen's bulk can thus be examined. A polarizer and analyzer may be used to eliminate disturbing reflections, greater depth of field may be achieved through use of insert diaphragms, and dipping cones (Fig. 3b) may be used to eliminate surface reflections. In certain samples, fine structural details are clearly visible only under extremely oblique illumination. This may be achieved by employing a relief condenser (Fig. 3c) for less powerful objectives or a mirror condenser in conjunction with objectives of higher magnification than 22X.

Total magnification is determined by

$$M = M_O M_E M_T M_C \quad (2)$$

where M_O is the objective magnification, M_E the eyepiece magnification, M_C the camera factor, and M_T

the tube factor (inclined eyepiece tubes usually introduce a M_T of 1.25, which is engraved on the tubes). M_C is defined as

$$M_C = L_B/Q \quad (3)$$

where L_B is the bellows length, and Q is a constant commonly set at 250 mm, which is the minimum distance of distinct vision of the eye.¹² A 3.8X incident objective and a 2.2X transmitted objective are the lowest power objectives obtainable commercially. Consequently, the above relation sets the lower magnification limit of the system with 5X eyepieces (which are also used in the camera's optical path, Fig. 2a) at 23.8X incident and 13.8X transmitted. For lower magnifications one has no choice but to rely on a cruder system and give up many of the useful Ortholux features previously mentioned.

Another limiting factor is the field of view. To determine the field of view in the specimen, the following relationship is used:

$$D = F_D/M_O M_T \quad (4)$$

where D is the diameter of the field in the specimen plane, and F_D is the field diameter of the eyepiece. Conventional microscope tubes are 23.2 mm in diameter and equipped with eyepieces with a maximum field of view of 18 mm in diameter. Therefore, the lowest transmitted objective (with $M_O = 2.2X$) and the lowest incident objective (with $M_O = 3.8X$) yield maximum system fields of view of 8.2 mm and 4.7 mm, respectively. Special wide tubes of 30-mm diameter (such as the Leitz GW series) are available, together with eyepieces with a 28-mm field of view. Using these numbers in eq 4 yields an absolute field of view for the system of no greater than 15.9 mm with transmitted objectives, and 9.2 mm with incident objectives. For wider field of view and/or lower magnification requirements the Leitz photographic system used alone (Fig. 2c) with the lenses suggested in Table AIII gives an additional close-up photographic capability.

The camera system

A system (Fig. 2b) equipped with a variable bellows and facilities for accepting 10.5-cm × 12.5 cm (4 × 5-in.) film has the versatility necessary for high-quality photomacrography. These bellows usually have an adjustable range from 100 mm to 600 mm.

THE BRIGHTFIELD OPTICAL MICROSCOPE

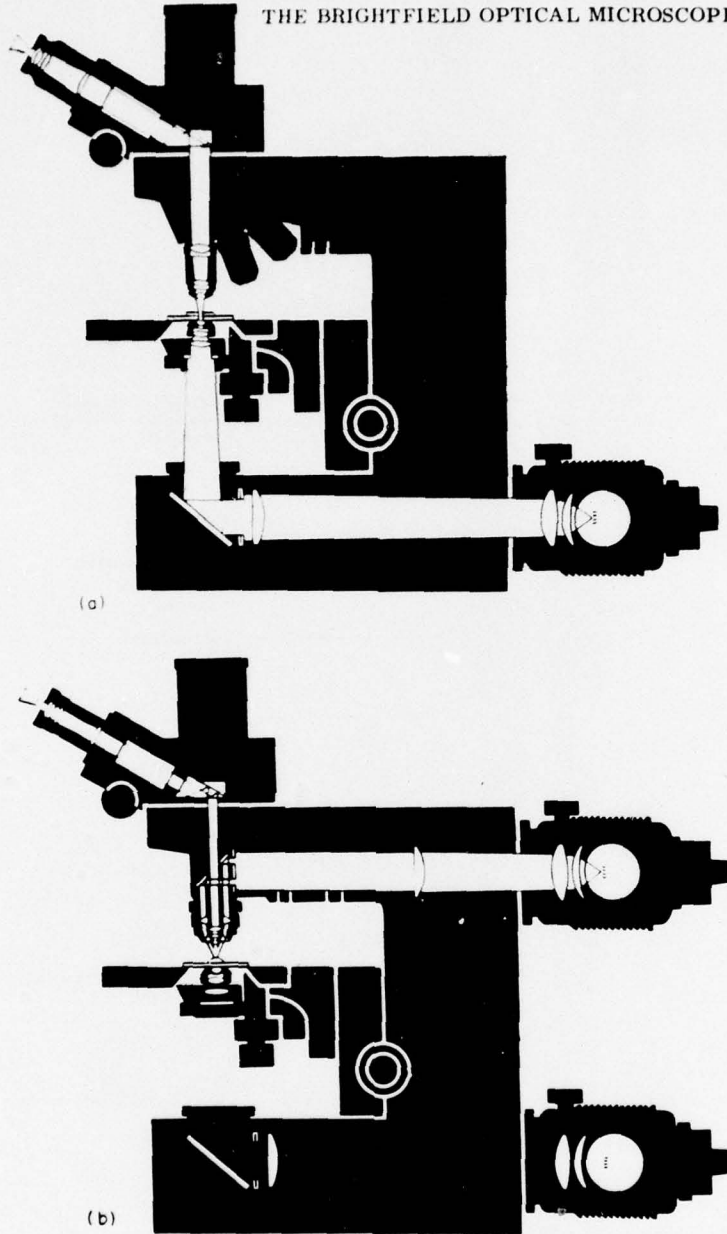
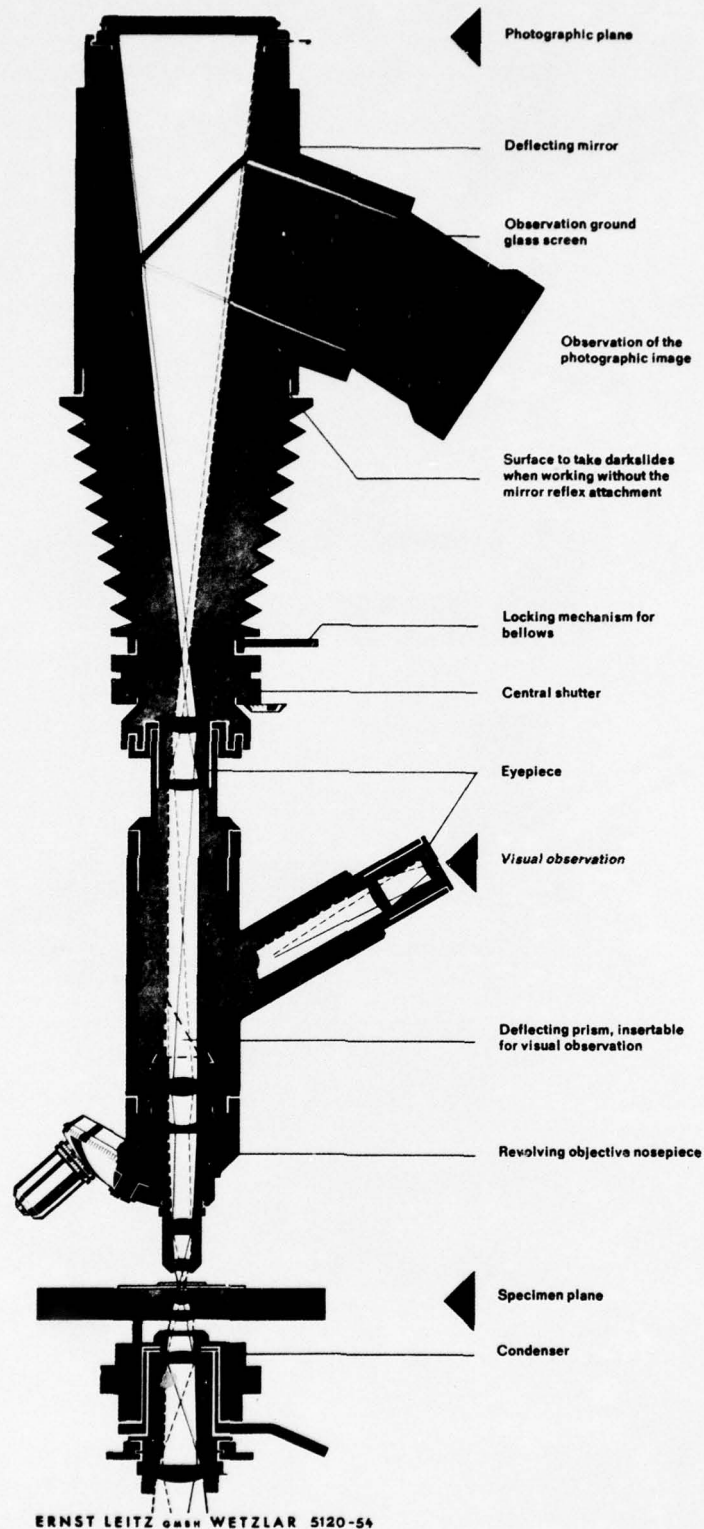

Figure 1. A typical (a) transmitted and (b) incident light microscope. (Reprinted by permission of E. Leitz, Inc.)

When Q in eq 3 is set at 250 mm (the microscopist's definition of normal viewing distance),¹² the beam may be switched back and forth from eyepiece to camera without refocusing. Therefore, the magnification at the film plane using any bellows is found from eq 4 where M_E is the eyepiece in the photographic

path and $M_C = 250/250 = 1$. The Polaroid 545 Land Film Holder together with Polapan Type 52 black and white 4-x5-in. film packets provide a convenient means of recording artifacts in transparent materials⁶ (Fig. 4).

Another widely used system employs a single-lens reflex (S.L.R.) camera with 35-mm film. The 35-mm



a. Optical path of the system.

Figure 2. The microscope-camera system used. (Reprinted by permission of E. Leitz, Inc.)

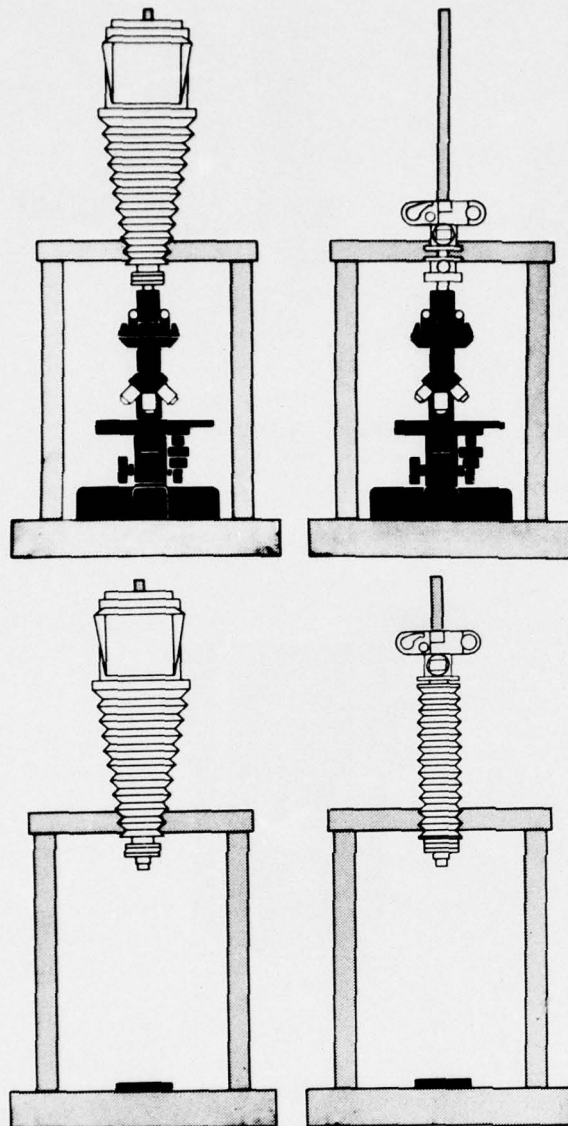

b. Photographic system used with microscope.

c. Photographic system used without microscope.

Figure 2 (cont'd).

S.L.R. (single lens reflex) camera body used was a Nikon F. All modern S.L.R. camera bodies are essentially similar and contain a film advance-rewind-count mechanism, a 1 to 1/1000 focal plane shutter, and a bayonet connector which allows the body to be attached to various accessories. The accessories used were extension tubes (Table AII), supplementary lenses (Table AI) and an adjustable bellows combined with a 12.5-mm to 120-mm selection of lenses (Table AIII). These tables, together with a selected

bibliography, are included to facilitate use of these accessories.

Tools for preparation of sample

A major problem in photographing artifacts in transparent materials is sample preparation and handling, which almost always require special innovative tools and techniques. In general, these problems are: size and configuration, surface characteristics, mounting into the microscope system, and ambient

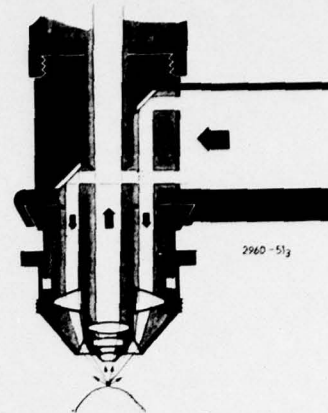
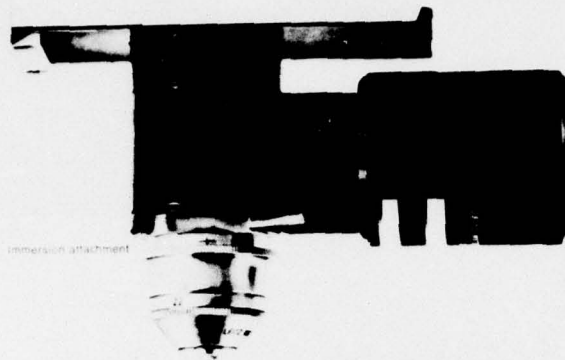

a. The Ultropak Incident Light Illuminator.

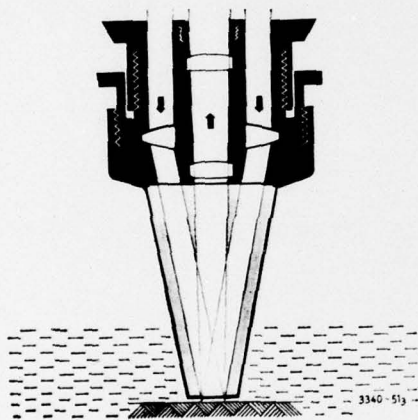

b. An attachment (dipping cone) designed to eliminate reflections from highly reflective surfaces such as ice.

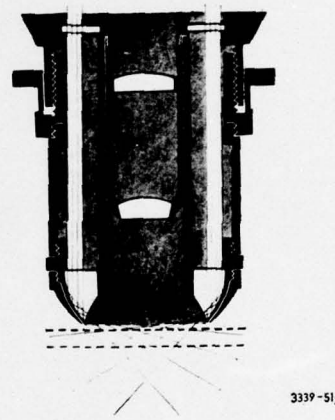

c. An attachment (relief condenser) designed to produce extremely oblique illumination necessary for photographing artifacts in transparent materials.

Figure 3. Illumination system used. (Reprinted by permission of E. Leitz, Inc.)

temperature, in samples such as ice. Examples of tools selected to overcome these problems for three types of samples are discussed below. The details for use of these tools will be given in a later section. These examples are not exhaustive but should serve to suggest innovations for solving special problems presented by a specific sample.

Ice. Tools that are useful in trimming ice to a usable configuration are an aluminum slab and a hot plate. For better control, an apparatus such as that shown in Figure 5a (to be referenced as the "Itagaki Apparatus") may be constructed.¹³ For improving the surface, thin cover glasses (i.e. Corning no. 1½, 22 mm) can be used with the hot plate. Another

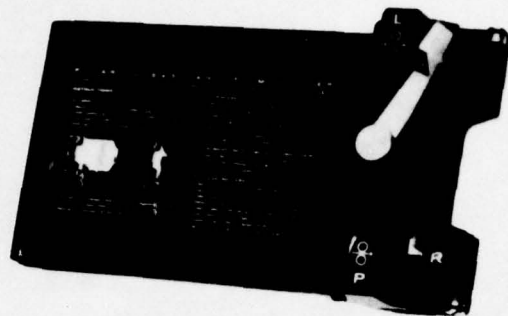

a. Sheet film holder, model 545.

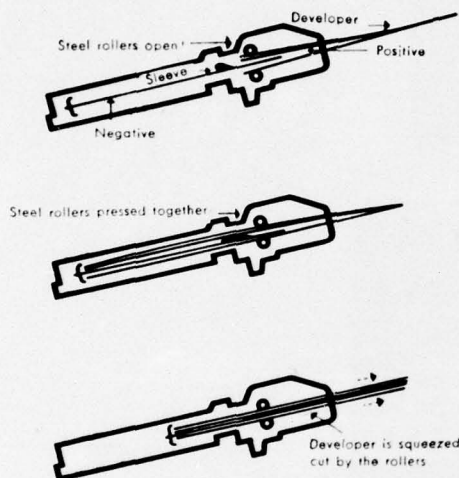

b. Development process of Polaroid sheet films.

Figure 4. Polaroid film holder.

useful tool is a sledge microtome, such as the Leitz-Wetzlar model 1700, shown in Figure 5b. This microtome can prepare several specimens simultaneously at thickness increments as small as $1 \mu\text{m}$, leaving behind a reasonably mechanically smooth surface.^{8 14}

Mounting problems may be solved by using a hot plate or other source of heat and a hypodermic needle filled with water. For ease in adjusting the sample for photographing from more than one perspective, a universal joint from a camera tripod, such as that shown in Figure 6b, may be added to the microscope system in place of the usual microscope stage. Since ice must be kept at temperatures below 0°C , an environment that will do this must, of course, be provided; the microscope system can either be placed in a cold-room or provided with a cold stage.

Lucite. Lucite can be trimmed with a saw and its surface smoothed at first with fine sandpaper and then with toothpaste or fine abrasives, such as those used by telescope manufacturers (Table I). Tallow and whiting can also be used for polishing.¹¹ Mounting problems may be solved with glue, mechanical stages (Fig. 7) or a solvent such as methyl ethyl ketone (MEK) that will soften a Lucite surface. The universal joint in Fig. 6 is useful for orienting a sample for photographing. The mechanically flat microtome stage is a good way to assure that mounted Lucite samples are all equally flat on a plane perpendicular to laser radiation. The microtome knife can be used to check surface flatness and assure uniform thickness among similar samples. It is not advisable to employ a microtome in cutting Lucite, however. Lucite does not

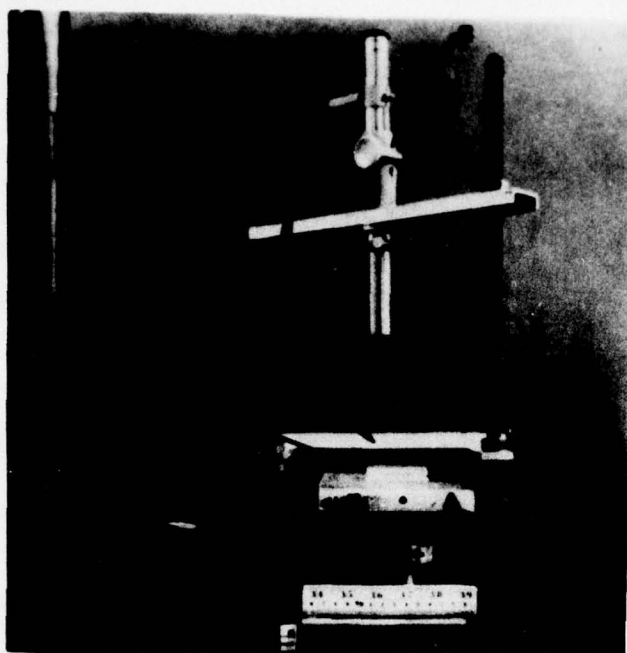

a. Itagaki apparatus: A) movable platform, B) laboratory jack, C) fixed supports, D) Lucite plate, E) rotatable head, F) telescope, G) ice sample, H) microscope slide, J) transformer.

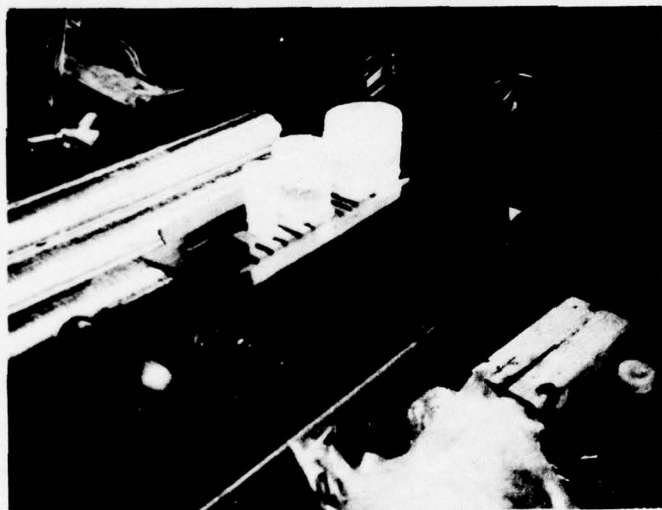

b. Sledge microtome.

Figure 5. Tools useful for preparing ice surfaces.

Table I. Mirror polishing abrasives listed from coarse to fine.

#80 Alundum	#600 Alundum
#120 Alundum	#305 Emery
#220 Alundum	Red jewelers' rouge
#320 Alundum	Cerium oxide
#400 Alundum	Barnesite

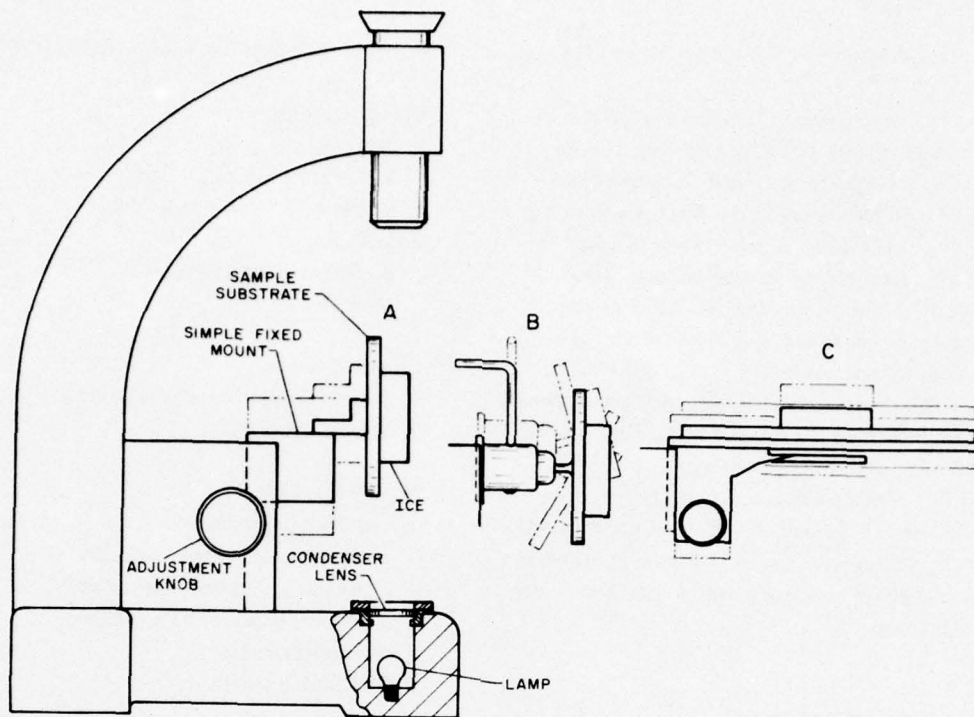

Figure 6. Microscope stage (C) replaced by universal joint (B) or bracket (A).

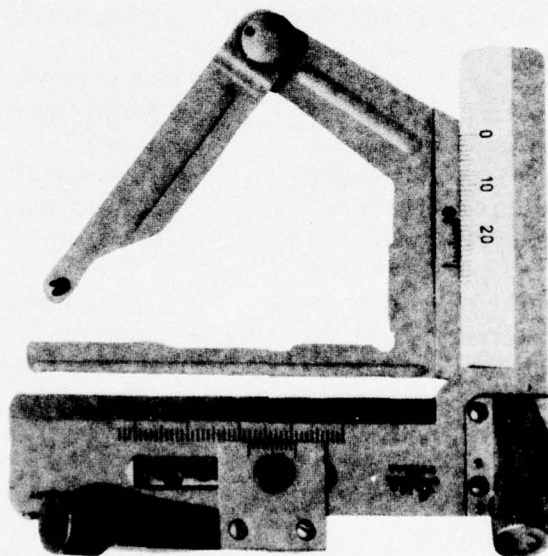

Figure 7. Attachable mechanical stage traversing area 40x20 mm, graduated vernier reading to 0.1 mm. (Reprinted by permission of E. Leitz, Inc.)

require any special environment but must be kept away from heat.

NaCl. The easiest way to trim NaCl samples is to take advantage of their crystalline cleavage planes. Ordinary razor blades (single edge) and a small hammer can be used for cleavage. For fine-scale thinning, either a microtome or a fine jet of water directed through a hypodermic needle may be used. Cleavage automatically produces a mirror surface. For storage, a dessicator filled with CaCl₂ or silica gel should be used to keep the specimens dry.⁵

BaF₂. BaF₂ crystals are bent slightly, then polished with a wool polishing felt rotating at between 64-132 rpm. Polishing solutions of 30% H₂SO₄ plus 70% H₂O and 40% HCl plus 60% H₂O are used. The crystals are cleaned with a solution of 80% aerosol OT and 20% acetic acid. The samples can be polished flat to within 1/10 wavelength of mercury greenlight and a rms roughness of 0.004 μm.¹

LABORATORY PROCEDURE

How one chooses to prepare a given sample for photomacrography is determined by the size and location of the artifact as well as the type of sample. There are two general types of artifacts as classified by location: those located at the surface of the sample and those located in the interior (or bulk) of the sample. Also, size generates two classifications of artifacts: those that require magnification before photographing and those that do not. Here, the microscope field of view of 4.5 mm is the approximate point where the decision between $M > 1$ and reduction is made. The following discussion will confine itself to ice and will give a detailed procedure for handling, preparing, and photographing such specimens. This will provide a specific example and the reader will be left to generalize the procedure to apply to his own type of sample.

Table II presents the basic outline of the procedure and can be used as a convenient checklist. This outline is amplified below.

Categorizing artifact

The first step in proceeding to photograph an artifact is to categorize it according to size, location, and material in which it is implanted. A large size is defined as having its longest dimension between 4 mm and 70 mm, and a small size would be between 0.01 mm and

Table II. Checklist for laboratory procedure.

- A. Categorizing artifact
 - 1. Size
 - a. Large (4 mm to 70 mm)
 - b. Small (0.01 mm to 4 mm)
 - 2. Location
 - a. Surface (front or rear)
 - b. Bulk
- B. Choosing setup
 - 1. 35-mm camera or bellows camera
 - 2. Microscope
- C. Preparing sample
 - 1. Handling substrate
 - a. Remove conductors (metals)
 - b. Orient insulators (non-metals)
 - 2. Trimming or sculpturing sample
 - 3. Mounting sample
 - 4. Identifying sample
- D. Illuminating sample
 - 1. Lighting for cameras
 - 2. Lighting for microscopes
- E. Photographing artifact
 - 1. Choosing exposure, speed, light level, film
 - 2. Focusing
 - a. Bellows at 250 mm
 - b. Ground glass
 - 3. Handling depth of field
 - a. Aperture
 - b. Multiexposure varying focus
 - 4. Handling environmental problems such as freezing, fogging, etc.

4 mm. An artifact's location would be either at the surface (front or rear) or in the bulk. The material would be either opaque or transparent, and environmentally stable or unstable. With this information in mind a photographic setup may now be chosen.

Choosing setup

A large artifact would require the choice of either a 35-mm camera with a micro lens or a bellows camera setup. The choice between these two would depend on

whether one has the facilities and/or the time to develop and process negative film. If not, the quick developing of Polaroid positive film would be an advantage. A microscope setup would be used to photograph small artifacts. The next step is to prepare the sample for photography.

Preparing sample

A sample such as ice must be prepared in a controlled environment. If the sample has a metallic substrate that interferes with the setup's ability to "see" the artifact, it may be removed by quickly and carefully heating the substrate until it falls off, then allowing the ice interface to solidify. One should practice with scrap samples until proficient in this technique. Unfortunately, porous nonmetallic substrates cannot be removed in this manner. Because of their low thermal conductivity the ice interface will be completely destroyed long before the substrate de-adheres. The only recourse is to orient the substrate carefully out of the optical path.*

Most of the ice surrounding the artifact may be carefully removed, so as to cut down scattering when illuminating by transmitted light or to better orient a smaller specimen in the confined area beneath a microscope objective. An aluminum slab heated on a hot plate will sculpture or trim ice accurately enough so that one may control the amount of ice removed without damage to the artifact site. Usually the new surface or window through which the microscope will look must be visually smooth — without visible ripples that cause shading contrast in the photograph. This surface should be level while it cools or held vertically until all the liquid water drains below the artifact and refreezes out of the way. Thin cover glasses may then be heated on the hot plate and gently pressed into place on the specimen to provide a surface which is smooth to the tolerance to which the glass is manufactured. As a variation of the above procedure, purposely allowing the liquid to freeze in ripples or hillocks in strategic locations can sometimes bring out certain characteristics of the artifact that are difficult to photograph.

The sledge microtome and the apparatus designed by Itagaki¹³ provide two ways of preparing samples prior to inflicting artifact damage. (Flat, smooth surfaces may be a requirement for studying such things as surface damage to materials.) Ice may be frozen to a microtome stage, making this aspect of

microtoming most convenient for this type of sample. (For mounting of other materials to the microtome stage see references 8 and 14.) The microtome can also slice off a portion of an extremely deep artifact, which cannot be captured photographically because of depth of field limitations, without altering the remainder. It is capable of slicing materials to within a few micrometers of the artifact, which is beyond the capability of the other two techniques. Again, practice on scrap samples is the best way to optimize these techniques before actually preparing valuable samples.

Providing space for a sample under a microscope, especially one including a substrate, is a problem that may best be resolved by removing the portion of the microscope stage that was designed to hold glass slides. The samples can then be mounted (or frozen in the case of ice) to the remaining rack and pinion portion that provides focusing adjustment. A small universal joint may be attached or frozen between the sample and this moving bar, which will provide three degrees of freedom for sample adjustment. Otherwise the sample will have to be sculptured further, risking alteration of the artifact.

For photographing with incident light, the sample may be placed on the complete stage just as a conventional glass slide is. (One must keep in mind that there is a limit to the amount of light that can be brought to bear on an ice sample, as hot light bulbs in some setups will melt or alter the artifact.) In some cases, ice samples will creep out of the field of view just as they are ready to photograph. Placing samples on a light table will work only for materials that are not heat-sensitive.

Cutting off a small portion of a transparent plastic ruler, calibrated in millimeters, and placing it as close to the artifact as possible is a convenient method of recording artifact size for surface defects. Placing such a scale on the surface when photographing into the depth of a sample is limited in that one must focus on the artifact instead of the scale. Although the scale in the photograph will not be in focus, this method is still better than having no reference at all. The ideal referencing method is to have a graduated eyepiece placed in the optical path of the camera. A sample may be identified by carefully writing an identifying number or other code on a piece of white paper and placing this in the field of view, but not in the way of the artifact. For magnifications where the field

* A newly discovered technique for preventing damage to ice when removing it from a metal substrate is the use of a microwave oven.

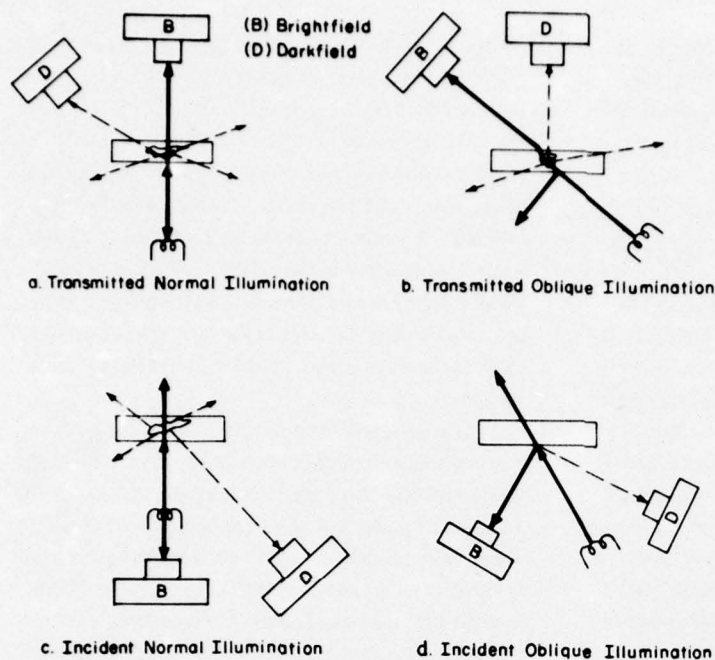

Figure 8. Four configurations of the photographic system.

of view is restricted, one has no choice but to remember to write on the back of the photograph as soon as it is pulled from the film holder. A log (such as DA Form 3315) should be kept when exposing 20 or 36 exposure 35-mm film. The numbers on the film will sometimes be off by one count, depending on where the operator started when he loaded the film, but they are still in numerical sequence. The individual frames should be compared with the log before they are cut into strips or individual frames.

Illuminating sample

In any photographic system there are essentially three parts: the source of illumination, the sample, and the camera. How these three parts are arranged with respect to each other determines the information that can be recorded in the photograph. Figure 8 shows four configurations of a general photographic system that will be discussed below. There are four general types of illumination: transmitted, incident, normal, and oblique. The first two terms describe where the illumination originates with respect to the sample and camera. The last two terms refer to the angular relationship between the illuminating beam and the sample.

If the sample is illuminated from one side while the camera is positioned on the opposite side, the photograph is being taken by "transmitted" light (Fig. 8a and b).

If the sample is illuminated on the same side as the camera, the photograph is being made by "incident" light (Fig. 8c and d). If the illuminating beam strikes the surface of the sample at an angle of 90° , then the photograph is said to be taken in the "normal" mode of illumination (Fig. 8a and 8c). If the illuminating beam strikes the surface of the sample at an angle substantially different from 90° , the photograph is said to be taken in the "oblique" mode of illumination (Fig. 8b and 8d).

Figure 8 also illustrates two major types of photography: "brightfield" and "darkfield." Once the illuminating beam interacts with the sample it is theoretically divided into transmitted, reflected, and scattered portions (see Fig. 9). Either the reflected or the transmitted portions will contain most of the intensity of the original beam, depending upon the nature of the sample. Those portions produce a "brightfield" photograph. When any of the scattered portion strikes the film, it produces a "darkfield" photograph.

The beam portion that is transmitted through the sample (without any change in direction) can provide information on the bulk of the sample; the portion that is reflected can provide information on the surface of the sample; and the portion that is scattered can provide information on irregularities that are not characteristic of the sample as a whole. In order to obtain

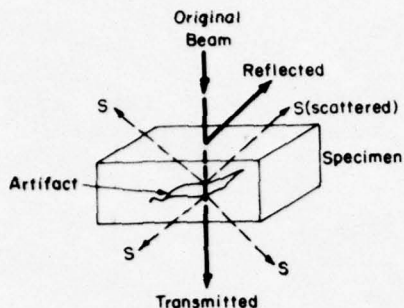

Figure 9. Transmitted, reflected, and scattered beams.

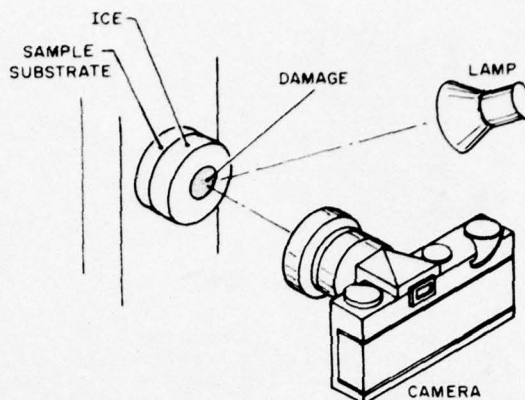

Figure 10. A practical camera setup for photographing artifacts in ice.

one of these various types of information, it is necessary to position the camera and the illumination system so that only the part of the beam that contains the desired information strikes the film plane.

The various configurations and photographs that are theoretically possible are shown in Figure 8. The configurations in Figure 8a and b are not practical for opaque specimens. The configurations in Figures 8a and c are most convenient for brightfield and those in Figures 8b and d for darkfield. For this reason, the oblique illumination mode is often equated with darkfield microscopy, but it is worthwhile to realize that oblique illumination is not the only way to observe a specimen by darkfield. If the camera can be mounted so that its position can be easily altered, it will be possible to select portions of the darkfield beams for study, no matter what illumination mode was selected. For example, in Figure 8a the darkfield camera could be moved (without changing sides of the sample) to intercept various portions of the scattered beam. This would provide a great deal more information about the sample.

Figures 10-12 illustrate the three most practical illumination setups for photographing artifacts in transparent materials. Figure 10 is a practical way to illuminate a sample for photography with a 35-mm camera using oblique illumination. A flat area with little or no contour is best lighted with the illuminator at a small angle to the normal optic axis as shown. Texture and contours may be best lighted with the illuminator set at a large angle to the normal over the specimen.

Figure 11 is a setup designed primarily for brightfield photography by transmitted-normal illumination which can also be used for darkfield with incident-oblique illumination. The intensity may be varied by adding or subtracting neutral density filters in addition to varying lamp voltage. This setup does not cause heat damage to ice samples as an ordinary photographer's light table may.

Figure 12 shows the technique for providing oblique-incident illumination to microscopes that are not normally equipped to handle this choice of illumination. The microscope's light bulb and condenser housing is removed and attached to a ring stand. This light source can be positioned above and to the right of the microscope stage just out of the field of view. Careful adjustment of the light in angular position and distance from the sample while viewing can be made to achieve the desired tonal qualities in the image. Sample photographs using these three setups will be displayed in the last section, *Results*.

Photographing artifact

A choice must now be made between a 35-mm camera with 20 or 36 exposure film or a bellows camera with a Polaroid sheet film attachment. Some of the advantages and disadvantages of both are as follows.

A 35-mm camera can use a great variety of film types, offering a wide range of film speeds and resolution (Table III). Many pictures may be quickly taken in sequence, and the development and printing methods may be varied in the darkroom to improve or alter final results. Incorrectly exposed negatives may be

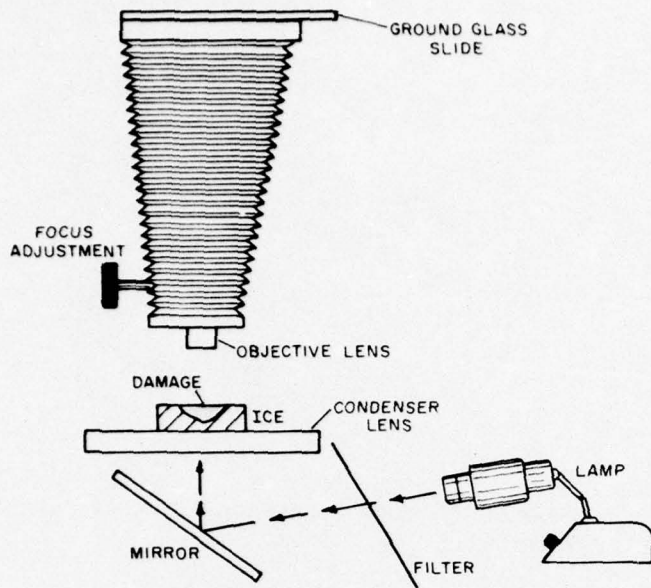
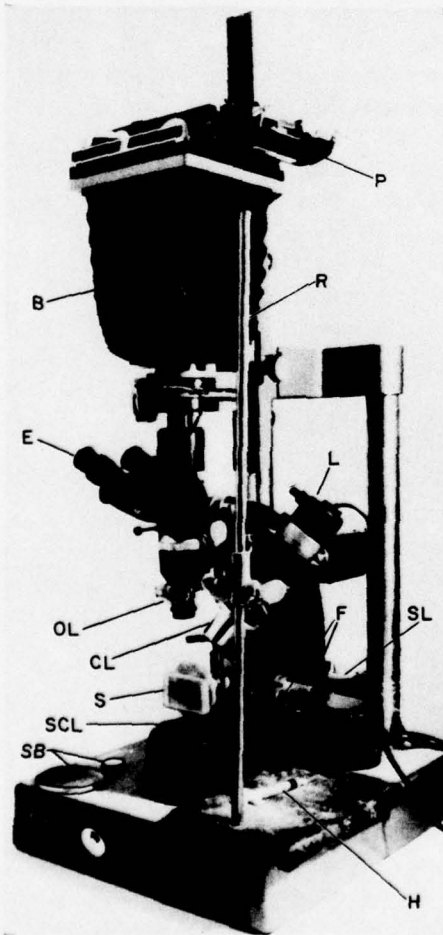

Figure 11. A practical transmitted light setup for photographing artifacts in ice.



- P Photographic plate holder
- R Ring stand supporting illuminating lamp
- B Bellows for camera
- E Binocular eyepiece
- L Illuminating lamp mounted to supply oblique, incident illumination to the sample
- OL Objective lens
- F Focusing controls
- CL Condenser lens attached to illuminating lamp
- SL Substage condenser lamp (not being used)
- S Sample mounted on universal mount
- SCL Well for substage condenser lens, which has been removed to allow use of universal mount
- SB Substrate discs used in preparation of samples
- H Hypodermic needle

Figure 12. A practical incident light setup for photographing artifacts in ice. (Reprinted by permission of E. Leitz, Inc.)

Table III. Available 35-mm Kodak films.

	ASA speed	Graininess	Resolving power	Process
Color slide films				
Kodachrome 25 film (daylight)	25	extremely fine	high	K-14 (lab only)
Kodachrome II professional film (type A)	40 (3200 K)	extremely fine	high	K-12 (lab only)
Kodachrome 64 film (daylight)	64	extremely fine	high	K-14 (lab only)
Kodak Ektachrome-X film (daylight)	64	very fine	medium	E-4 (lab or user)
Kodak high speed Ektachrome film (daylight)	160	very fine	low	E-4 (lab or user)
Kodak high speed Ektachrome film (tungsten)	125 (3200 K)	very fine	low	E-4 (lab or user)
Color negative films (for prints)				
Kodacolor II film (daylight)	80	microfine	medium	C-41 (lab or user)
*Kodak Vericolor II professional film, type S (daylight)	100	extremely fine	medium	C-41 (lab or user)
*Kodak Vericolor II professional film, type L (1/50-1/5 sec)	80 (3200 K)	extremely fine	medium	C-41 (lab or user)
Black-and-white films (for prints)				
Kodak Panatomic-X film	32	extremely fine	very high	(black-and-white developers)
Kodak Plus-X pan film	125	extremely fine	high	(black-and-white developers)
Kodak Verichrome pan film	125	extremely fine	high	(black-and-white developers)
Kodak Tri-X pan film	400	fine	high	(black-and-white developers)
Special-purpose films				
Kodak recording film 2475 (Estar-AH base) (extremely high-speed black-and-white film)	effective 1000-4000	coarse	medium	(recommended black-and-white developers)
Kodak Royal-X pan film (extremely high-speed black-and-white film)	1250	medium	medium	(recommended black-and-white developers)
Kodak high contrast copy film 5069 (very sharp black-and-white film for making greatly reduced copies. Can be used as a continuous-tone film with special processing)	64 (tungsten)	extremely fine	ultra high	(recommended black-and-white developers)
*Kodak Ektachrome infrared film (false-color slide film)	100 (daylight, w/#12 filter)	fine (with process EA-5)	medium (with process EA-5)	ME-4 EA-5 E-4 (lab or user)
*Kodak high speed infrared film (black-and-white negative film)	50 (daylight w/#25 filter)	moderately coarse	medium	(recommended black-and-white developers)

* Intended mainly for professional use.

saved by applying special chemicals and processes designed for that purpose. Slide film may be used for audience presentation. Duplicates may be easily made and the original prints and negatives are more easily preserved.

Polaroid film provides an almost instant display of results. The photographs may be quickly analyzed and studied and any gross errors or equipment malfunctions quickly noted and corrected. The image may be projected on a ground glass slide, focused, composed, and enlarged. (This is impossible to do with most 35-mm cameras after they have been loaded, since access to the film plane is restricted.) An annoying disadvantage of the Polaroid process, however, is that the rollers tend to get dirty and jam the film, causing partial coating and developing of the picture or multiple spotting (Fig. 4). Also, duplication of Polaroid pictures can be difficult.

A correlation exists between emulsion speed and grain size for all films. Faster film is coarser grained and so is less capable of recording detail. The most suitable combination is one of ultra-fine grain and ultra-thin emulsion layer, since these produce the sharpest possible image owing to the intrinsic resolving power of the emulsion and the reduction of scatter in the thin layer itself. Slow film speed is usually acceptable for photomacrography of transparent artifacts. A filter may also be used to enhance resolution by shortening the wavelength of the rays used. Blue light has about twice the resolving power of red light.

Exposure is changed either by adjusting the shutter speed, inserting neutral density filters or varying the intensity of the light at the source or through the aperture. The brighter the illumination, the shorter the exposure time. Exposure time also varies as the square of the total magnification and inversely as the square of the numerical aperture.

When working with a 35-mm camera it is a good idea to "bracket" the chosen exposure setting by snapping two additional exposures with settings on either side of it. This increases the probability of producing a successful photograph by allowing for errors in judging the proper exposure needed for tricky transparent specimens.

A simple way to choose exposure settings when using sheet film is to pull out the darkslide sleeve only one-quarter of the way and expose the film. Then, keeping the same settings, one can pull out one-half, expose again, and continue this process for three-quarters and full. When developed, the four contrasting

exposures will give an approximate idea of what settings to use. When very slow shutter speeds are used, some shutters tend to become sluggish in a cold environment. The best way to compensate for this is to snap the shutter several times at the chosen setting before the darkslide is pulled. It is also a good idea to keep the type 500 film holder outside the cold-room when loaded with film and take it out immediately after exposing. Low temperature affects exposure time and retards the ability of the developer to spread evenly over the photograph surface while being pulled for development.

Focusing a single-lens reflex 35-mm camera is no problem at close distances. The microscope may be focused in the normal manner by operating the coarse and fine focusing controls, even though part of the stage has been removed to accommodate the sample. If the bellows length of the camera is kept at 250 mm, the image will usually be in focus on the photographic surface and one may take the picture without further adjustment. For best results it is advisable to: 1) place a ground-glass slide in place of the film holder, 2) open the aperture as widely as possible, 3) open the shutter, 4) turn up the illumination, 5) turn off the room lights for maximum contrast, and 6) adjust the image in order to perfect details of interest. Image adjustment must be done when examining artifacts in the bulk, as their depth and orientation usually require decisions to be made about which aspects or characteristics one wishes to photograph. The illumination should be increased and the aperture "stopped down" before shooting the picture.

Depth of field (Figure A3) is a problem that must be considered when trying to photograph artifacts with depth of detail. An objective lens with an adjustable aperture contained within it is a useful tool; some microscope tubes (such as the Leitz FS 45) have an adjustable pinhole diaphragm built into the optical path. The depth of field may be increased by decreasing the magnification and the aperture size, or by increasing the focal length, which is a fixed length in a commercial microscope. As the aperture diaphragm is reduced in diameter, the depth of field increases while the image brightness is reduced. The ideal setting is that which yields just the required depth of field. Multiple exposures of the same artifact while varying the focus slightly between shots is a technique that will sometimes work successfully.⁷

If a lens is stopped down all the way, the resulting photograph will be in focus over a wide range of

distances on both sides of the chosen focus setting. This hyperfocal distance is usually engraved in some manner on modern 35-mm camera focusing rings but is not found on laboratory cameras. Unfortunately, total gathered light is sharply reduced at small apertures which may require higher film speeds.

Moisture and dust are enemies of a successful photograph. Once a lens is badly scratched or a shutter pitted, all future efforts are impaired. A piece of apparatus should never be taken from a cold area to a warm area unless it is wrapped in plastic to allow moisture to condense on the plastic instead of the delicate surfaces. Lens tissue should be kept handy to clean a lens, as the temptation to use ordinary tissue or a finger could ruin optical surfaces. Since dust settles on equipment even in coldrooms, it should be covered when not in use. Such simple housekeeping practices are necessary in order to assure good photography.

RESULTS

Figures 13-15 are photographs of artifacts that illustrate the results that can be obtained with the procedures discussed above and with the three practical setups shown schematically in Figures 10-12.

Figure 13a is a brightfield photograph of a Bausch and Lomb glass calibration slide. The field surrounding the ruled lines does not appear to be seriously scratched or dirty. Yet the darkfield photograph of the same surface, shown in Figure 13b, dramatically displays the full extent of the damage and dirt. This is a good illustration of the advantage of darkfield over lightfield illumination in revealing surface artifacts. Figure 14a shows a highly polished (to visual inspection) plexi-glass surface that exhibits extensive surface damage when examined by darkfield.

The damage site in the bulk (produced by the laser beam) in Figure 14a is out of focus since the lens was focused on the surface. In order to photograph the artifact in the bulk by transmitted illumination, the surface should be further polished.

Figure 14b, another photograph of this artifact, illustrates the lack of detail from limitations in depth of field caused by using a large aperture. An aperture of around $f/32$ would correct this situation but would require a substantial increase in the intensity of illumination. This photograph was also an attempt to use both transmitted and incident illumination in varying

amounts at the same time in order to enhance the contrast and better define the artifact. It can be seen that this procedure is not successful and should be avoided in favor of other techniques.

Figures 15a and b demonstrate the use of a 35-mm camera with black and white film and a micro lens (see Fig. 10) to photograph "large" artifacts (on the order of a few centimeters) in polycrystalline ice. Some 35-mm cameras can be used with fractional diopters, bellows extension tubes, or lens reversal tubes. However, an adjustable focus micro lens is the most convenient way to photograph large artifacts in transparent materials at distances of less than the conventional lens minimum focal distance of about 0.5 m. Oblique incident lighting was used. The bubbles and strains, characteristic of polycrystalline ice, are also clearly shown in these two photographs.

Figure 15c shows a six-sided crack in a single crystal of ice. It is a "small" artifact in ice adhering to a glass slide, which lent itself well to the technique of using a simple bellows camera with transmitted normal illumination (Fig. 11). Polaroid high-speed type 57 film was used (ASA 3000) which called for settings of $f/5.6$ at $1/50$ s. The sample sat on a condenser lens that was cool enough not to melt the bulk of the sample, but the lens did supply enough heat to cause the sample to tend to creep out of the field of view.

Figure 15d shows an artifact at the interface between a concrete substrate and ice. A bellows camera attached to a microscope with a Zeiss lens containing an adjustable aperture was used (Fig. 12). Superfluous ice was removed, as described above, in order to allow illumination by transmitted light. The substitution of a fabricated mounting for the usual stage of the microscope allowed the side view of the artifact to be photographed without undue alteration of the sample. However, use of the universal joint mount could have improved the results.

Figure 15e shows an artifact that contains a bubble path extending through the bulk of an ice specimen, adhering to a substrate. The universal joint allowed the bulk of the brightfield beam to be diverted from the central portion of the photograph which was produced by darkfield beams. Leaving a poorly sculptured surface, as suggested in the section on procedure, helped to scatter enough light to give the artifact satisfactory contrast. The arrow in the photograph points to the artifact.

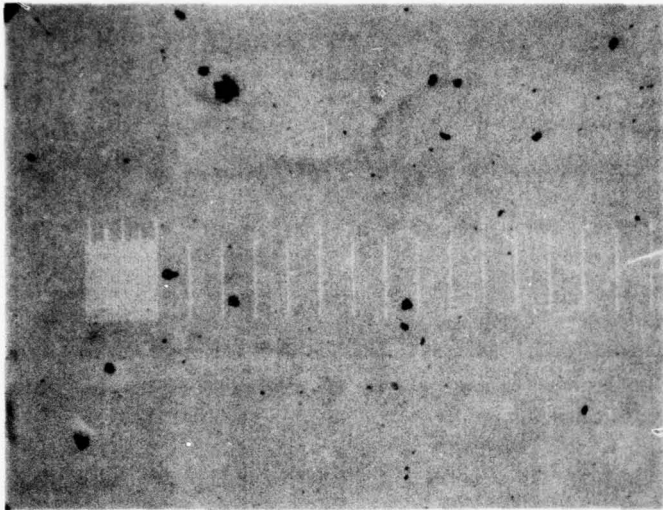

a. Brightfield.

Size: Small
Location: Front surface
Setup: Bellows & Microscope
Preparation: No substrate
Illumination: Transmitted normal
Settings: 1/5 s
4 amps
Magnification: 50X

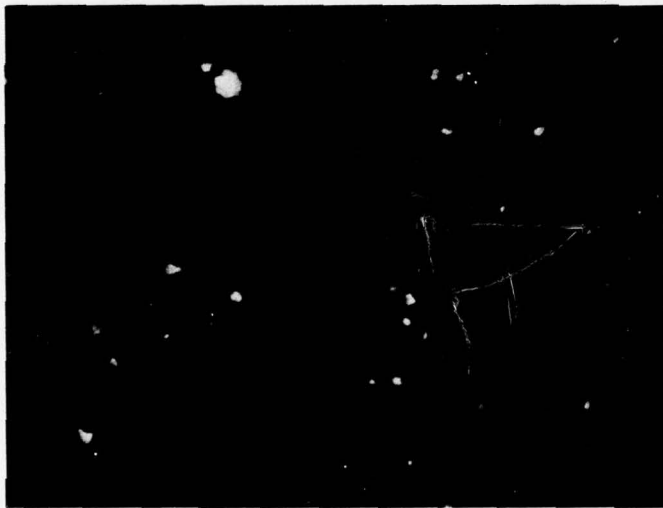

b. Darkfield.

Size: Small
Location: Front surface
Setup: Bellows & Microscope
Preparation: No substrate
Illumination: Incident normal
Settings: 1/5 s
5 amps
Magnification: 50X

Figure 13. Photograph of a Bausch and Lomb glass calibration slide.



a. Darkfield photograph showing surface scratches.

Size: Large
Location: Front surface
Setup: Bellows & Microscope
Preparation: No substrate
Illumination: Incident normal
Settings: 1/5 s
5 amps
Magnification: 50X

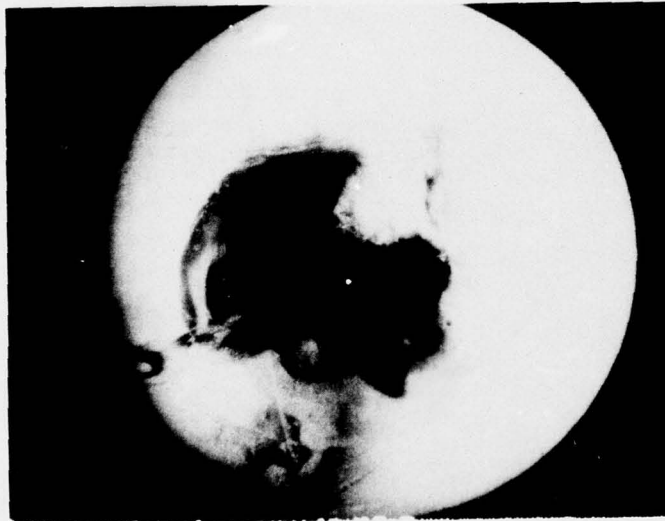

b. Photograph illustrating lack of depth of field.

Size: Large
Location: Bulk
Setup: Bellows & Microscope
Preparation: Highly polished top surface
Illumination: Normal incident and transmission
Settings: 1/2 s
5X lens
4A trans
4A incident
No depth of field
Magnification: 50X

Figure 14. Photograph of artifact damage in Lucite.

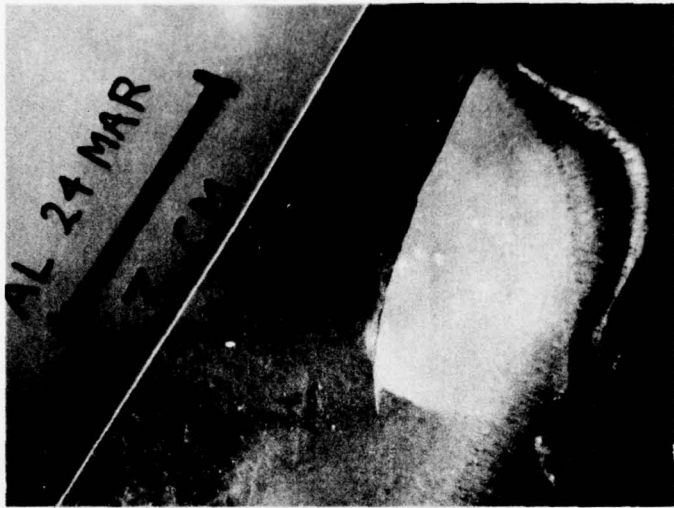

a. 35-mm format print showing large crack in ice with aluminum substrate.

Size: Large

Location: Extends through bulk from front to rear surface of sample

Setup: 35-mm camera

Preparation: 1) Al substrate is in place
2) fixed, flat surface mounting

Illumination: Incident/oblique

Magnification: 1.7X

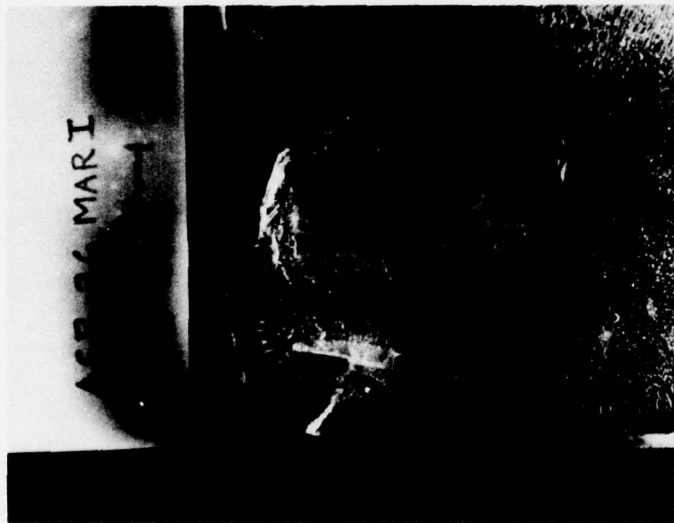

b. 35-mm format print showing large crack in ice with asphalt substrate.

Size: Large

Location: Extends through bulk from front to rear surface of sample

Setup: 35-mm camera

Preparation: 1) Asphalt substrate is in place

Illumination: Incident/oblique

Magnification: 1.7X

Figure 15. Photographs of damage sites in ice.

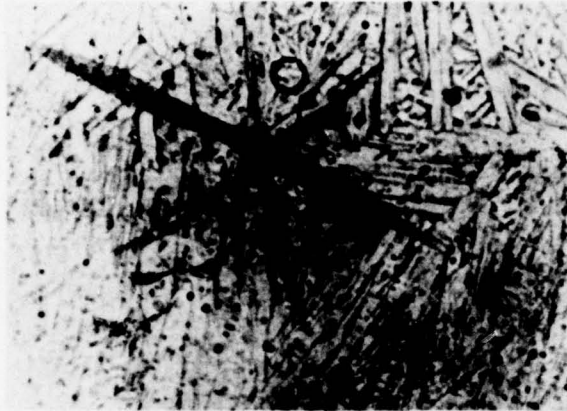

c. Single crystal ice.

Size: Small
Location: Bulk of sample
Setup: Bellows camera
Preparation: 1) Glass substrate is not
in place
2) Fixed stage mounting
Illumination: Trans/normal
Settings: 1/50 s
Magnification: 9X

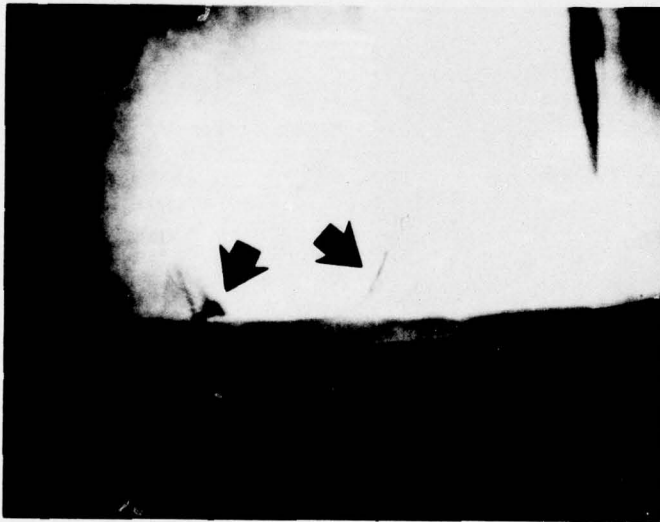

d. Ice side view.

Size: Small
Location: Rear surface of ice (inter-
face)
Setup: Bellows camera with micro-
scope
Preparation: 1) Concrete substrate is
in place
2) Fixed, fabricated
mounting
Illumination: Trans/normal
Settings: 1/50 s
4 amps
Magnification: 45X

Figure 15 (cont'd).



e. Single crystal ice mounted on glass substrate with bubble damage path in bulk.

Size: Small
Location: Bulk
Setup: Bellows camera with microscope
Preparation: 1) Glass substrate is in place
2) Fixed, fabricated Al mounting
Illumination: Trans/normal
Settings: 1/50 s at f/22
Magnification: 45X



f. Single crystal ice with keyhole-shaped damage site.

Size: Small
Location: Front surface of ice
Setup: Bellows camera
Preparation: 1) Glass substrate is in place
2) Universal mounting
Illumination: Oblique
Settings: 1/50 s at f/22
Magnification: 6X

Figure 15 (cont'd). Photographs of damage sites in ice.



g. Single crystal ice, top view of same site as in f.

Figure 15 (cont'd).

Figure 15f is a photograph of an artifact in the surface of a 0.3 cm-thick specimen of ice mounted on a glass substrate. This keyhole-shaped artifact was produced at the surface by laser irradiation. Before photographing, the surface was prepared by the techniques described above. Figure 15g is the same artifact as photographed from the side. Cracks fan out in a spherical bowl-shaped pattern from the front surface, with several longer flares in evidence. This is an example of how oblique illumination can be adjusted incrementally until the most satisfactory conditions are met for a good photograph. It shows how a photographic system can be modified to allow an artifact to be photographed from more than one perspective, thus displaying its full three-dimensional character.

LITERATURE CITED

1. Bis, R.F., E.N. Farabaugh and E.P. Muth (1976) Preparation of polished substrates of BaF₂. *Journal of Applied Physics*, vol. 47, no. 2, p. 736.
2. Glass, A.J. and A.H. Guenther (Eds.) (1973) Laser induced damage in optical materials. National Bureau of Standards Special Publication 387.
3. Gufkins, R.C. (1970) *Optical microscopy of metals*. New York: American Elsevier.
4. Hellwarth, R., (1972) Fundamental absorption mechanisms in high-power laser window materials. NBS Special Publication 372.
5. Hines, R.L. (1975) Crystal film preparation by cleavage. *Journal of Microscopy*, vol. 10, part 3, p. 257.
6. Kornman, H. and K. Sleibach (1965) The Polaroid process in photomicrography. *Leitz Science and Technical Information*, vol. 1, no. 1, p. 82.
7. Lawson, D. (1972) *Photomicrography*. London: Academic Press, p. 49.
8. Leitz-Wetzlar (undated) Treatment and maintenance of microtome knives. E. Leitz, Inc., Rockleigh, N.J.
9. Martin, R.J. and W.B. Durham (1975) Mechanisms of crack growth in quartz. *Journal of Geophysical Research*, vol. 80, no. 35, p. 4837.
10. Ready, J.F. (1971) *Effects of high-power laser radiation*. Chapter 6, Damage in transparent materials. New York: Academic Press.
11. Rohm and Haas (undated) *How to work with plexiglass*. Industrial Plastics Supply Catalog 70, West Hartford, Conn.
12. Sears, F.W. (1949) *Optics*. Cambridge, Mass: Addison-Wesley Press, p. 260.
13. Tobin, T.M. and K. Itagaki (1970) A technique for producing strain-free flat surfaces on single

Size: Small

Location: Front surface of ice

Setup: Bellows camera

Preparation: 1) Glass slide is in place
2) Universal mounting

Illumination: Trans/oblique

Settings: 1/50 s at f/22

Magnification: 6X

- crystals of ice. *Journal of Glaciology*, vol. 9, p. 57.
14. Walter, F. (1971) The microtome: A guide to specimen preparation and section cutting. Technisch-Padagogischer Verlag, Frankfurt.

SELECTED BIBLIOGRAPHY

- Croy, Otto R. (1961) *Same size and larger than life photography*. London: Focal Press.
- Eastman Kodak Co. (1935) *Photomicrography: An introduction to photography with the microscope*. Eastman Kodak Company, Rochester, New York.
- Eastman Kodak Co. (1966) *Photography through the microscope*. Kodak Technical Publication P-2, Eastman Kodak Co., Rochester, New York.
- Gibson, H.L. (1970) *Close-up photography and photomacrography*. Kodak Technical Publication N-16, Eastman Kodak Co., Rochester, New York.
- Greenleaf, A.R. (1950) *Photographic optics*. New York: Macmillan.
- Hartley, W.G. (1964) *How to use a microscope*. New York: Natural History Press.
- Hoidale, G.B. (1964) The color identification of transparent crystalline particles with an optical microscope. ERDA-165, White Sands Missile Range, New Mexico.
- Hyzer, W.G. (1975) Photography: Macro or micro? *Research/Development*, June 1975, p. 22-25.
- Kruszna-Krausz (Ed.) (1965) *The focal encyclopedia of photography*. London: Focal Press.
- Malies, H.A. (1959) *Applied microscopy and photomicrography*. London: Fountain Press.
- Papert, J. (1971) *Photomacrography: Art and techniques*. New York: Amphoto.
- Ponder and Best, Inc. (1972) *Vivitar bellows system owner's manual*. Ponder and Best, Inc., Los Angeles, California.
- Richardson, J.H. (1971) *Optical microscopy for the materials sciences*. New York: Marcel Dekker.
- Schenk, R. and G. Kistler (1962) *Photomicrography: An introduction to the principles of the microscope and its application to the practice of photomicrography*. New Jersey: Franklin Publishing Company.
- Simmons, R. (1961) *Close-up photography and copying*. New York: Amphoto.
- Time-Life Books (1971) *Photographing nature*. Life Library of Photography, New York: Time, Inc.
- Tolke, Arnim and Ingeborg (1971) *Macrophoto and cine methods*. Focal Press.

APPENDIX. REFERENCE INFORMATION FOR PHOTOMACRO-
GRAPHIC AND PHOTOMICROGRAPHIC APPLICATIONS

SECTION I. TABLES FOR CLOSE-UP RANGE (Tables AI-AIII)

Table AI. Table for general close-up photography for supplementary lenses. (Reprinted by permission of Time, Inc.).

supplementary lens	camera setting (feet)	subject distance (inches)	approximate image reduction using 50mm lens	approximate area covered (inches) using 50mm lens	approximate depth of field (inches) at f/8
+1 diopter (1 m. focal length)	infinity	39	.05x	19 x 28	9
	20	34	.06x	16 x 24	6½
	10	30	.07x	14 x 21	5
	5	23¾	.08x	11 x 16½	3
	3	18¾	.11x	8½ x 12¾	2
	2	14¾	.14x	6½ x 10	1
+2 diopters (500mm focal length)	infinity	19½	.10x	9½ x 14	2½
	20	18¼	.11x	8¾ x 13	2
	10	17	.12x	8 x 12	1¾
	5	15	.14x	7 x 10½	1¼
	3	12½	.16x	5¾ x 8½	¾
	2	10½	.20x	4¾ x 7	½
+3 diopters (333mm focal length)	infinity	13	.15x	6 x 9	1
	20	12½	.15x	6 x 9	1
	10	12	.16x	5¾ x 8½	¾
	5	10¾	.18x	5 x 7¼	¾
	3	9½	.22x	4¼ x 6¼	½
	2	8¾	.26x	3¾ x 5½	¾
+4 diopters (250mm focal length)	infinity	9½	.20x	4½ x 7	½
	10	9	.22x	4¼ x 6¼	½
	5	8½	.24x	4 x 6	½
	2	7	.30x	3½ x 4¾	¼
+5 diopters (200mm focal length)	infinity	8	.25x	3¾ x 5	¾
	5	7	.30x	3¼ x 4¾	¾
	2	6½	.33x	3 x 4½	¼
+6 diopters (167mm focal length)	infinity	6½	.30x	3¼ x 4¾	¼
	2	5¼	.38x	2¼ x 3½	½

This chart shows how supplementary lenses can be used. The columns showing image reduction and area covered apply only to a 50mm lens (or any lenses from 45 to 55mm used on a 35mm camera). The other columns are valid for camera lenses of any focal length. The chart is particularly applicable for rangefinder and twin-lens cameras (page 100). Since the focusing mechanisms of these cameras cannot be used accurately at close distances, the "subject

distance" must be measured physically. The figures refer to the precise distance between the subject and the front face of the supplementary lens. The image reduction column indicates the relation between the size of the image on the film and life size; thus the number .10x means that the image on the film is one tenth life size. The depth of field is given for an aperture set at f/8. Accordingly, at an aperture of f/4, divide each figure in half; at f/16, double each figure.

Table AII. General close-up range table for extension tubes. (Reprinted by permission of Focal Press, Ltd.)

Focal Length of Camera Lens	Scale of Reproduction with Extension Tube of										
	$\frac{1}{2}$ in. 1.3 cm.	$\frac{3}{8}$ in. 1.9 cm.	1 in. 2.5 cm.	$1\frac{1}{4}$ in. 3.8 cm.	2 in. 5 cm.	$2\frac{1}{2}$ in. 6.3 cm.	3 in. 7.5 cm.	$3\frac{1}{2}$ in. 9 cm.	4 in. 10 cm.	6 in. 15 cm.	
2	5	0.25-0.31	0.38-0.44	0.5-0.56	0.75-0.81	1.00-1.06	1.25	1.5	1.75	2	3
$2\frac{1}{2}$	6.25	0.2-0.27	0.3-0.37	0.4-0.47	0.6-0.67	0.80-0.87	1.00-1.07	1.2	1.4	1.6	2.4
3	7.5	0.17-0.25	0.25-0.33	0.33-0.41	0.5-0.58	0.67-0.75	0.83-0.91	1.00-1.08	1.16	1.33	2
$3\frac{1}{2}$	9	0.14-0.24	0.21-0.31	0.29-0.39	0.43-0.53	0.57-0.67	0.72-0.82	0.86-0.96	1.00-1.10	1.14	1.7
4	10	0.12-0.24	0.19-0.31	0.25-0.37	0.37-0.49	0.50-0.62	0.63-0.75	0.75-0.87	0.87-0.99	1.00-1.12	1.5
$4\frac{1}{2}$	11.2	0.11-0.26	0.17-0.32	0.22-0.37	0.33-0.48	0.44-0.59	0.55-0.70	0.67-0.82	0.78-0.93	0.89-1.04	1.33
5	12.5	0.10-0.17	0.15-0.22	0.20-0.27	0.27-0.34	0.40-0.47	0.50-0.57	0.60-0.67	0.70-0.77	0.80-0.87	1.2
$5\frac{1}{2}$	13.7	0.09-0.16	0.14-0.21	0.18-0.25	0.27-0.34	0.36-0.43	0.45-0.52	0.55-0.62	0.64-0.71	0.73-0.81	1.1
6	15	—	0.12-0.21	0.16-0.25	0.20-0.29	0.33-0.42	0.42-0.51	0.50-0.59	0.57-0.66	0.67-0.76	1
7	17.5	—	0.11-0.22	0.14-0.25	0.21-0.32	0.29-0.40	0.36-0.47	0.43-0.54	0.50-0.61	0.57-0.68	0.85-0.96
8	20	—	—	0.12-0.18	0.19-0.25	0.25-0.31	0.31-0.37	0.38-0.44	0.44-0.50	0.50-0.56	0.75-0.81
10	25	—	—	—	0.15-0.22	0.20-0.27	0.25-0.32	0.30-0.37	0.35-0.42	0.40-0.47	0.60-0.67
12	30	—	—	—	—	0.17-0.26	0.21-0.30	0.25-0.34	0.29-0.38	0.33-0.42	0.50-0.59

There is not much point in using short extension tubes with long focus lenses, as the focusing extension is often longer than the extension tube.

Table AIII. Table for macro objective lenses with built-in adjustable aperture. (Reprinted by permission of E. Leitz, Inc.)

TYPE OF OBJECTIVE	FOCAL LENGTH MM	NUMERICAL APERTURE	RELATIVE OPENING
PHOTAR 12.5mm	12.4	0.26	1:1.9
PHOTAR 25mm	25	0.20	1:2.5
PHOTAR 50mm	51	0.12	1:4
PHOTAR 50mm	52	0.18	1:2.8
PHOTAR 80mm	81	0.11	1:4.5
PHOTAR 120mm	123	0.09	1:5.6

SECTION II. WORKING CURVES FOR GENERAL PHOTOMACROGRAPHY RANGE (Fig. A1 and A2)

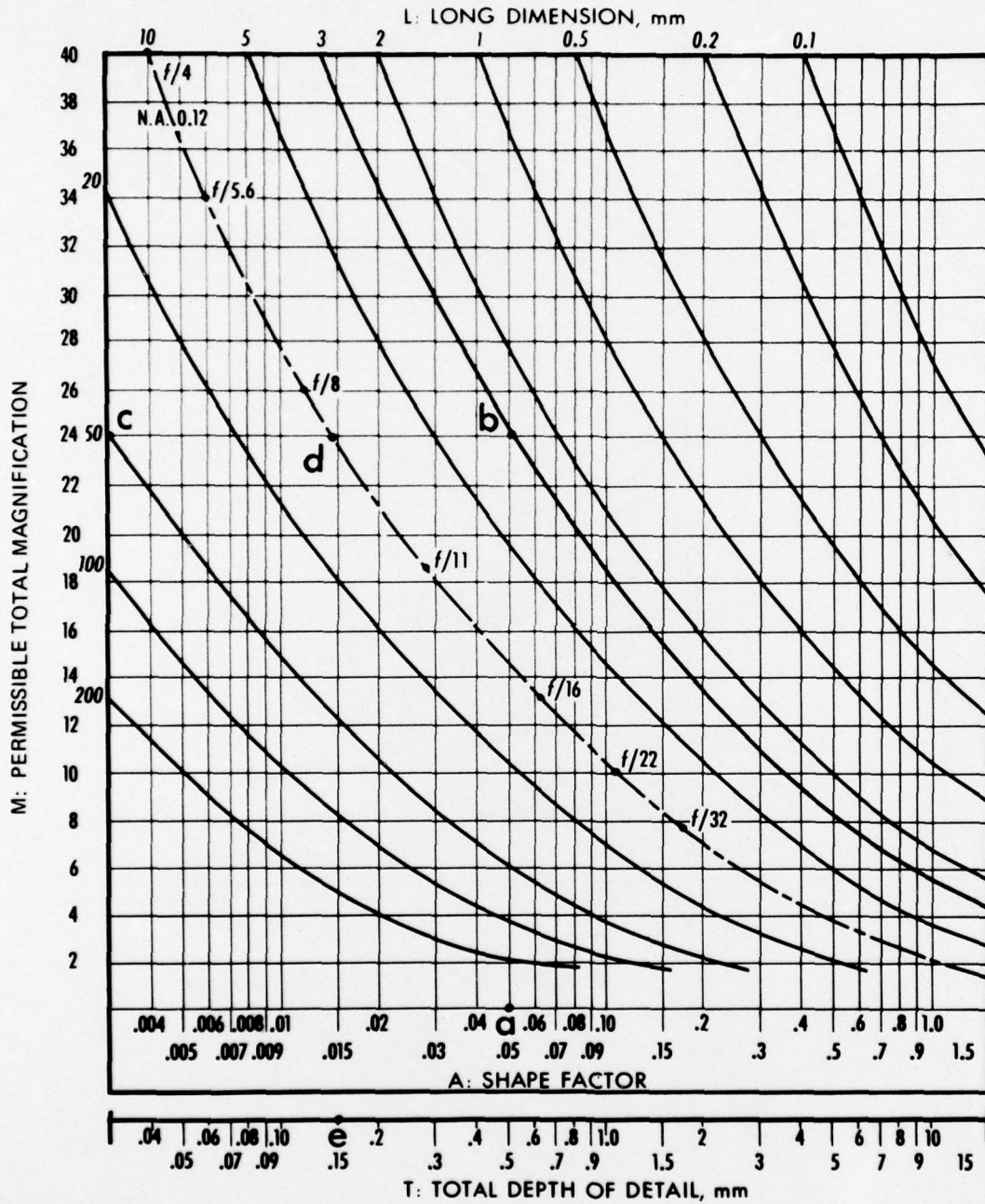

Figure A1. Permissible total magnification vs long dimension, shape factor and depth of detail. (Copyright Eastman Kodak Company, 1970).

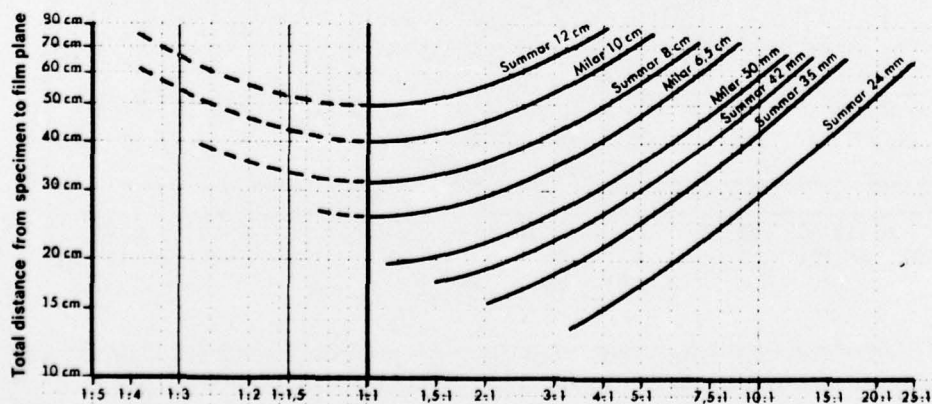
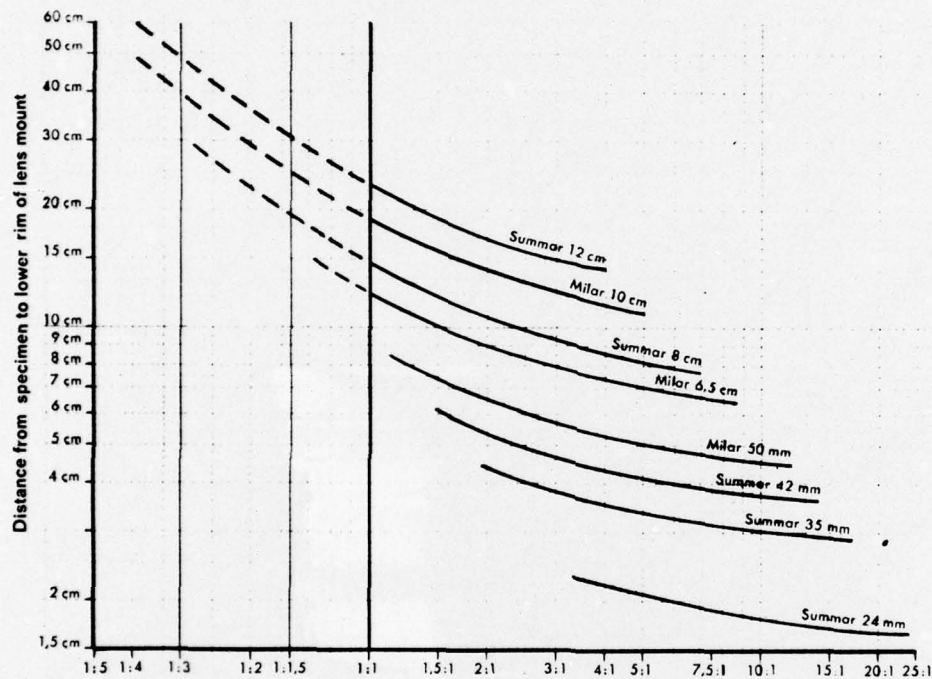
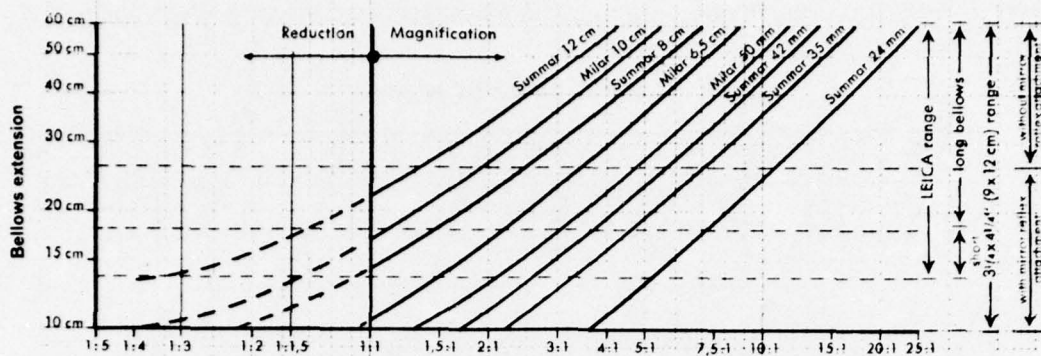

Figure A2. Table for bellows camera with interchangeable lenses. (Reprinted by permission of E. Leitz, Inc.)

SECTION III. REFERENCE DATA FOR GENERAL PHOTOMICROGRAPHIC RANGE (Tables AIV, AV, Fig. A3)

Table AIV. Eyepieces for photomicrographic range. (Reprinted by permission of E. Leitz, Inc.)

Huygens eyepieces	<i>Field diam (mm)</i>
Inexpensive eyepieces with normal field of view, primarily for low and medium power objectives.	<i>Magnification</i>
Huygens eyepieces can also be used with high power objectives but better results are obtained in such cases with periplanatic eyepieces.	6X 19.0
	6X 16.7
	10X 13.6
	16X 10.0
	Micrometer- eyepiece
	6X M 17.5
 Periplanatic eyepieces	 <i>Field diam (mm)</i>
With normal field of view for medium and high power objectives and especially for all fluorite and apochromatic systems.	<i>Magnification</i>
	P 6X 19.5
	P 6X 18.0
	P 8X 16.0
	P 10X 15.2
	P 12X 13.0
	P 15X 12.5
 Periplanatic wide-field eyepieces	 <i>Field diam (mm)</i>
Plano objectives should be used only with these eyepieces.	<i>Magnification</i>
For binocular observations the GF 25X M micrometer eyepiece can be paired with a normal GF 25X eyepiece.	GF 10X 18.0
	GF 16X 15.0
	GF 20X 12.0
	GF 25X 10.0
	Micrometer- eyepiece
	GF 25X M 10.0
 High-point eyepieces	 <i>Field diam (mm)</i>
Since the exit pupil of the microscope is usually only just above the level of the eyepiece top it is not possible for spectacle wearers to get close enough to the exit pupil to see the entire field of view. For persons wearing spectacles special eyepieces have therefore been designed in which the distance separating the eyelens and the exit pupil has been sufficiently increased.	<i>Magnification</i>
	Huygens
	6.3X 20.0
	6.3X 16.8
	Periplanatic
	P 10X 14.0

Table AV. Objectives for micrographic range. (Reprinted by permission of E. Leitz, Inc.)

Objectives for Brightfield-Darkfield Transmitted Light
Corrected for 170mm Tube Length

Type of Objective	Magnification/ Aperture	Focal Length MM	Free Working Distance MM	Type of Eyepiece	Cover Glass Correction
Pi Plano Achromatic Objectives 45mm Adjustment Length	Pi Apo 6.3/0.20	27.8	9.2	P	DO
	Pi Apo 16/0.40	10.5	1.22	P	DO
	Pi Apo 25/0.65	7.24	0.65	P	D
	Pi Apo 40/0.75	4.0	0.44	P	D
	Pi Apo Oil 40/1.00		0.22	P	D
	Pi Apo Oil 63/0.95		0.15	P	D
	Pi Apo Oil 100/1.32	1.76	0.25	P	D
Pi Plano Fluorite Objectives 45mm Adjustment Length	Pi Fi 10/0.30	18	6.9	P	DO
Pi Plano Achromatic Ob- jectives 45mm Adjustment Length	Pi 1/0.04 ^(A) with iris diaphragm & condenser	33	30	P	DO
	Pi 2.5/0.08	56	11	P	DO
NPL Plano Achromatic Ob- jectives 45mm Adjustment Length	NPL 6.3/0.20	24	2.0	P	DO
	NPL 10/0.25	16	0.53	P	DO
	NPL 16/0.40	11	0.50	P	D
	NPL 25/0.50	7.0	0.38	P	D
	NPL 40/0.65	4.5	0.15	P	D
	NPL 63/0.90		0.12		
Fluorite Objectives 37mm Adjustment Length	NPL Oil 100/1.30	1.7	0.26	P	D
	Fi 40/0.85	4.3	0.28	P	D ¹
	Fi 40/0.85	4.3	0.28	P	O
	Fi 63/0.85 ^(B)		0.14	P	D
	Fi Oil 54/0.95	3.4	0.17	P	DO
	Fi Oil 95/1.32	2.0	0.12	P	D
	Iris Fi Oil 95/1.32-1.10	2.0	0.12	P	D
Fluorescence Ob- jectives (for use without cover glass) 37mm Adjustment Length	Apo 25/0.65 Fluor	7.4	0.76	P	DO
	Fi 40/0.85 Fluor	4.3	0.33	P	O
	Fi Oil 95/1.32 Fluor	2.0	0.12	P	O

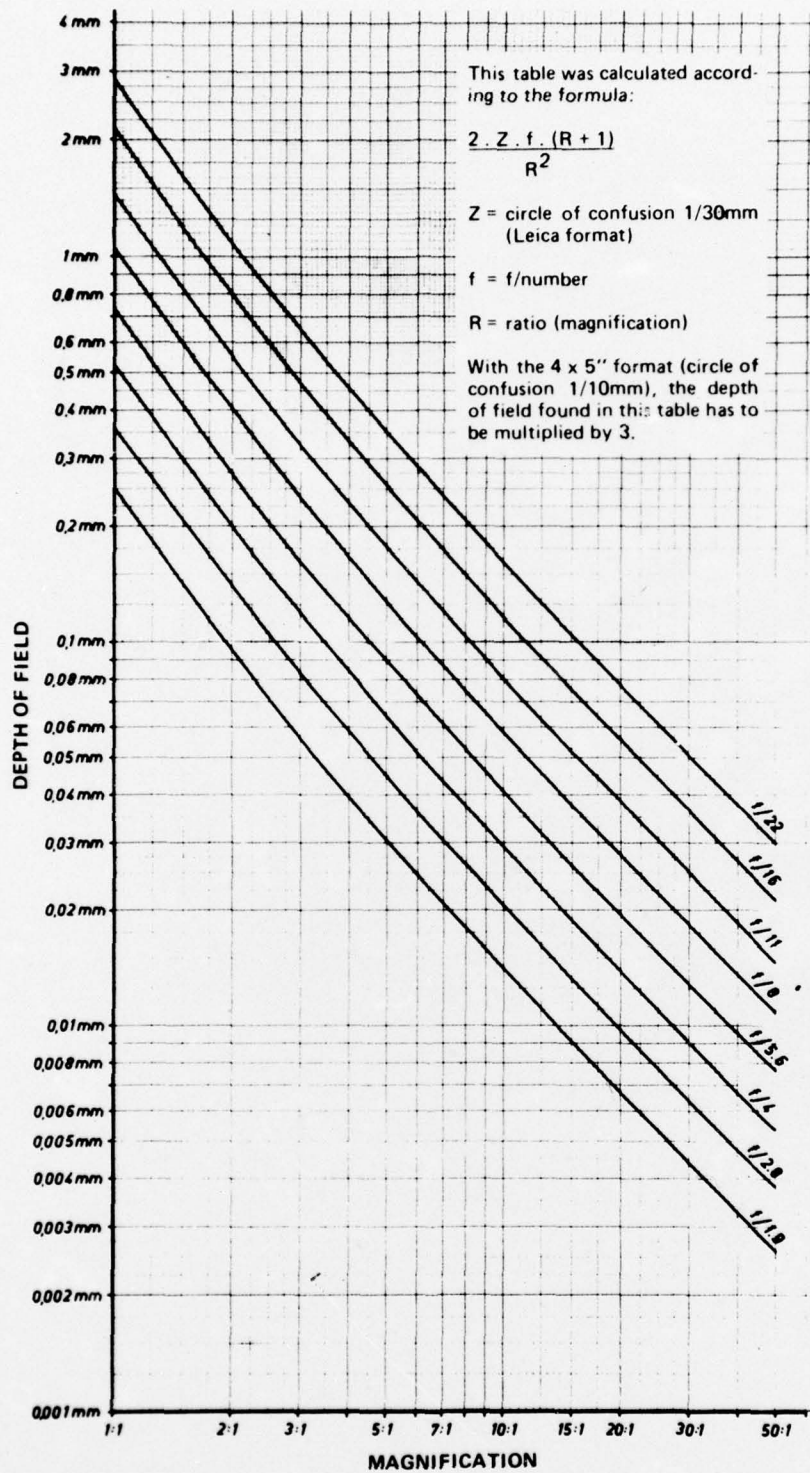

Figure A3. Depth of field by the general micrographic range. (Reprinted by permission of E. Leitz, Inc.)