

AD-A033 709

PRC INFORMATION SCIENCES CO ROME N Y  
SPACE SURVEILLANCE SOFTWARE SUPPORT, VOLUME III, RADAR SIGNATUR--ETC(U)  
OCT 76 P R CONTI

F/6 15/3

F30602-75-C-0167

UNCLASSIFIED

RADC-TR-76-261-VOL-3

NL

1 of 3  
AD  
A033709

The main body of the document is a grid of 78 small, square panels arranged in 6 rows and 13 columns. Each panel contains a different type of data visualization or text, which is mostly illegible due to the low resolution and high contrast of the scan. The panels appear to be organized into sections, with some containing what looks like code or data tables, and others containing plots or diagrams. The overall layout is a dense array of technical information.

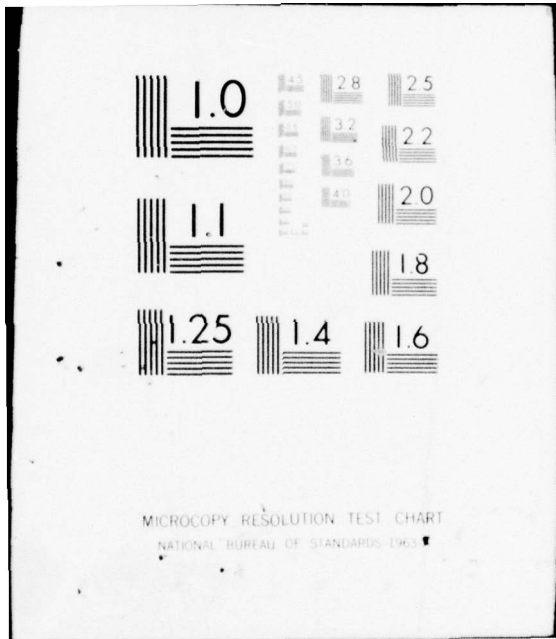

ADA033709

RADC-TR-76-261, Volume III  
Final Technical Report  
October 1976

12  
f.s.



SPACE SURVEILLANCE SOFTWARE SUPPORT  
Radar Signature and Radar Scattering Principles  
Investigation Software

PRC Information Sciences Company

Approved for public release;  
distribution unlimited.

ROME AIR DEVELOPMENT CENTER  
AIR FORCE SYSTEMS COMMAND  
GRIFFISS AIR FORCE BASE, NEW YORK 13441

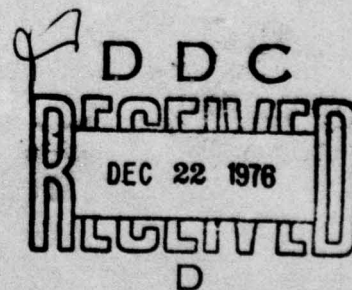

This report contains a large percentage of machine-produced copy which is not of the highest printing quality but because of economical consideration, it was determined in the best interest of the government that they be used in this publication.

This report has been reviewed by the RADC Information Office (OI) and is releasable to the National Technical Information Service (NTIS). At NTIS it will be releasable to the general public, including foreign nations.

This report has been reviewed and approved for publication.

APPROVED:

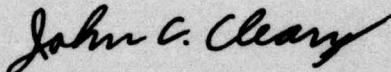

JOHN C. CLEARY  
Project Engineer

APPROVED:

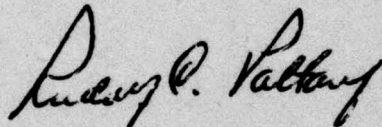

RUDOLF C. PALTAUF, Lt Col, USAF  
Chief, Surveillance Division

FOR THE COMMANDER:

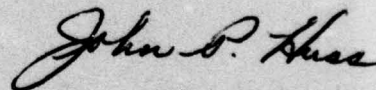

JOHN P. HUSS  
Acting Chief, Plans Office

Do not return this copy. Retain or destroy.

UNCLASSIFIED

SECURITY CLASSIFICATION OF THIS PAGE (When Data Entered)

REPORT DOCUMENTATION PAGE		READ INSTRUCTIONS BEFORE COMPLETING FORM
1. REPORT NUMBER RADC-TR-76-261, Vol III ✓	2. GOVT ACCESSION NO.	3. RECIPIENT'S CATALOG NUMBER 9
4. TITLE (and Subtitle) SPACE SURVEILLANCE SOFTWARE SUPPORT. Volume III Radar Signature and Radar Scattering Principles Investigation Software,	5. TYPE OF REPORT & PERIOD COVERED Final Technical Report April 1975 - July 1976	6. PERFORMING ORG. REPORT NUMBER N/A
7. AUTHOR(s) P. Richard Conti	8. CONTRACT OR GRANT NUMBER(s) F30602-75-C-0167 ✓	
9. PERFORMING ORGANIZATION NAME AND ADDRESS PRC Information Sciences Company 8606 Turin Road Rome NY 13440	10. PROGRAM ELEMENT, PROJECT, TASK AREA & WORK UNIT NUMBERS 62702F 65121205	
11. CONTROLLING OFFICE NAME AND ADDRESS Rome Air Development Center (OCSA) Griffiss AFB NY 13441	12. REPORT DATE October 1976	
14. MONITORING AGENCY NAME & ADDRESS (if different from Controlling Office) Same	13. NUMBER OF PAGES 273	15. SECURITY CLASS. (of this report) UNCLASSIFIED
16. DISTRIBUTION STATEMENT (of this Report) Approved for public release; distribution unlimited. 16 6512 17 12	15a. DECLASSIFICATION/DOWNGRADING SCHEDULE N/A	
17. DISTRIBUTION STATEMENT (of the abstract entered in Block 20, if different from Report) Same 18 RADC 19 TR-76-261-Vol-3		
18. SUPPLEMENTARY NOTES RADC Project Engineer: John C. Cleary (OCSA)		
19. KEY WORDS (Continue on reverse side if necessary and identify by block number) Trajectory Radar Cross Section Orbit Classifiers		
20. ABSTRACT (Continue on reverse side if necessary and identify by block number) The objective of this effort was to modify the RADC trajectory program, orbit program and various radar cross section programs were modified to run on the RADC HIS 6180 computer under the GCOS system software. The RADC trajectory program was modified to include the capability of processing multiple (20) radar sites and multiple (20) targets in the program so that various radar parameters could be determined. This type of information is essential in performing radar coverage analyses for systems such as COBRA TALON, SEEK SAIL, COBRA DANE and COBRA JUDY. This portion of the effort is documented in Vol 1.		

DD FORM 1473

EDITION OF 1 NOV 68 IS OBSOLETE

UNCLASSIFIED

SECURITY CLASSIFICATION OF THIS PAGE (When Data Entered)

409280

over  
10

UNCLASSIFIED

SECURITY CLASSIFICATION OF THIS PAGE(When Data Entered)

Line 20 (continued)

Volume ~~II~~<sup>2</sup> documents a procedure for punching cards in ASCII format and reading the data onto a HP cassette for subsequent plotting with an HP 9820 calculator system.

Vol ~~III~~<sup>3</sup> documents some Radar Signature and Radar Scattering computer programs. A three-dimensional plot program contained in this volume has been incorporated into the Interactive Radar Simulator for plotting three-dimensional antenna patterns and cross section aspect angle histories.

UNCLASSIFIED

SECURITY CLASSIFICATION OF THIS PAGE(When Data Entered)

## ABSTRACT

The objective of the effort documented herein was to provide computer programming support for Space Surveillance system analysis. The two primary tasks of the effort were to complete the modification of the RADC Trajectory Program and to modify various radar cross-section and other computer programs so that they could be accessed from the interactive system for the RADC Radar Simulator. The documentation is organized as follows:

Volume I, Part 1, Book 1 - Project Summary and Computer Program Documentation (Chapters I-III of Volume I, Part 1)

Volume I, Part 1, Book 2 - Computer Program Documentation (Chapter IV)

Volume I, Part 1, Book 3 - Computer Program Documentation (Chapters V-VI and Appendices A-E)

Volume I, Part 2 - RADC Trajectory Program - Numerical/Analytical Data

Volume II - Generalized Data Entry and Plot Program

Volume III - Radar Signature and Radar Scattering Principles Investigation Software

for		
White Section	<input checked="" type="checkbox"/>	
Buff Section	<input type="checkbox"/>	
UNCLASSIFIED	<input type="checkbox"/>	
CLASSIFICATION		
SECURITY/AVAILABILITY CODES		
SPECIAL		
A		

DDC  
RECEIVED  
DEC 22 1976  
D

SECTION I

INTRODUCTION

The computer programs documented in this section of the report were originally developed by the Fort Worth Division of General Dynamics, under Contracts F30602-69-C-0164 and F30602-67-C-007. PRC has installed these programs on the RADC HIS 6180 GECOS Time Sharing System. Some of the programs need minor cleaning up since the test expired. Each Roman Numeral Section has its own Table of Contents.

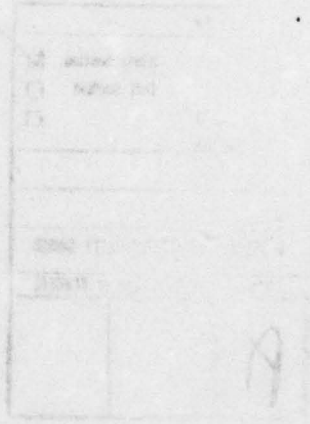
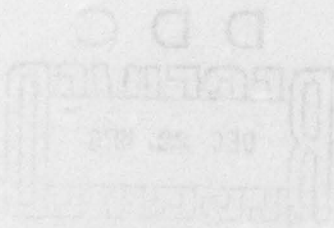

TABLE OF CONTENTS

<u>SECTION</u>		<u>PAGE</u>
I	Introduction	ii
II	SP3D Program	1
III	DISCRM	47
IV	A36 Signature Superposition	94
V	AG2 Matched Filter	138
VI	AG3 Polarization Signature Technique	159
VII	Signature-Type Ambiguity	186
	Introduction to Sections VIII, IX and X	217
VIII	SPECT	218
IX	CLASS	245
X	TRAIN	254

(the reverse of this page is blank)

SECTION II

SP3D

COMPUTER PROGRAM DOCUMENTATION

## TABLE OF CONTENTS

<u>SECTION</u>	<u>TITLE</u>	<u>PAGE</u>
1	SCOPE	3
2	APPLICABLE DOCUMENTS	4
3	REQUIREMENTS	5
3.1	CP Characteristics	5
3.1.1	CP Flow Chart	
3.1.2	CP Timing	
3.1.3	Storage Allocation	
3.1.4	Data Base Characteristics	
3.2	Computer Program Subroutine Characteristics	7
3.2.1	Executive Routine	7
3.2.1.1	Description of Executive Routine	
3.2.1.2	Flow Chart	
3.2.1.3	Interfaces	
3.2.1.4	Limitations	
3.2.1.5	Listing	
3.2.2	Computer Program Subroutine SP3D	19
3.2.2.1	Description of Subroutine SP3D	
3.2.2.2	Subroutine SP3D Flow Chart	
3.2.2.3	Interfaces	
3.2.2.4	Listing	
3.2.3	Computer Program Subroutine DATAIN	38
3.2.3.1	Description of Subroutine DATAIN	
3.2.3.2	Interfaces	
3.2.3.3	Listing	
4	TEST DESCRIPTION	41
4.1	Input Data	41
4.2	Output Data	42

## S E C T I O N 1

### S C O P E

This specification establishes the requirements for complete identification and acceptance of the computer program to be formally accepted by the procuring agency. EDP program SP3D was originally written by the Convair Aerospace Division of General Dynamics for use with an IBM 360 computer system under contract F30(602)-69-C-0164; however, the necessary changes have been incorporated to make the program compatible with the GE 635/645 computer system at RADC. This documentation has been prepared in accordance with the RADC Computer Program Detail Specification, 28 January 1968.

S E C T I O N 2

A P P L I C A B L E D O C U M E N T S

The documents, of exact issue shown, form a part of this specification to the extent specified herein. In the event of conflict between documents referenced here and the detail content of Sections 3, 4, and 5, the detailed contents of Sections 3 through 5 shall be considered as superseding requirements.

- |   |           |
|---|-----------|
| 1. GE-600 Line FORTRAN IV                         | CPB-1006G |
| 2. GE-600 Line FORTRAN IV<br>Subroutine Libraries | CPB-1620  |
| 3. GE-600 Line General Loader                     | CPB-1008F |
| 4. GE-600 Line System Editor                      | CPB-1138C |

## S E C T I O N 3

### R E Q U I R E M E N T S

Computer program SP3D has as its primary function the display, in a psuedo three-dimensional form, of edited short-pulse radar signature data. The program has available several capabilities for use by the customer in displaying this data. These capabilities include the ability to:

1. Select any file on tape to be plotted
2. Select whether to plot amplitude data only or amplitude and phase data
3. Select the number of sweeps displayed
4. Select the oblique skew desired
5. Display data expressed in voltage or decibels.

#### 3.1 CP CHARACTERISTICS

Computer program SP3D, which consists of an executive routine, subroutine SP3D and subroutine DATAIN, is described in detail in the following paragraphs.

##### 3.1.1 CP Flow Chart

Figures 1 and 2 depict the overall flow of the computer program.

##### 3.1.2 CP Timing

Run time for the sample problem was less than 8 minutes.

##### 3.1.3 Storage Allocation

58K is the minimum memory needed to load SP3D with all files open.

##### 3.1.4 Data Base Characteristics

Radar signature input data for this program are contained on 7-track magnetic tape recorded at 556 bpi. Figure 3 contains a detailed description of the tape format.

	1	2	4	8	A	B	C	
1	1	1	1	1	1	1	1	Record Prefix (=)
2	/	/	/	/	/	/	/	MSD Model Number
3	/	/	/	/	/	/	/	LSD or Calibration Data Code
4	/	/	/	/	/	/	/	Run Number (Used when all other identifiers are repeated)
5	/	/	/	/	/	/	/	Frequency (1-UHF, 2-L-Band, 3-S-Band, 4-C-Band, 5-X-Band)
6					1	1		Blank
7	/	/	/	/	/	/	/	Polarization (Trans-RCV:1-VV, 2-HH, 3-VH, 4-HV)
8	/	/	/	/	/	/	/	MSD
9	/	/	/	/	/	/	/	Full Scale Range Sweep in inches
10	/	/	/	/	/	/	/	LSD
11					1	1		Blank
12	/	/	/	/	/	/	/	MSD
13	/	/	/	/	/	/	/	Record Number (Progressive from 0000)
14	/	/	/	/	/	/	/	
15	/	/	/	/	/	/	/	LSD
16	1				1			Data Prefix (/)
17	/	/	/	/	/	/	/	MSD Block Number
18	/	/	/	/	/	/	/	LSD (00 for this application)
19					1	1		Blank
20					1	1		Blank
21					X	1	X	Sign
22	1				1		X	MSD
23	1				1		X	
24	1				1		X	± 9999
25	1				1		X	LSD
26					X	1	X	Sign
27	X	X	X	X	X		X	MSD
28	X	X	X	X	X		X	In-phase component
29	X	X	X	X	X		X	in Millivolts
30	X	X	X	X	X		X	LSD
31					X	1	X	Sign
32	X	X	X	X	X		X	MSD
33	X	X	X	X	X		X	Quadrature component
34	X	X	X	X	X		X	in Millivolts
35	X	X	X	X	X		X	LSD
36					X	1	X	Sign
37	X	X	X	X	X		X	MSD
38	X	X	X	X	X		X	Amplitude Component
39	X	X	X	X	X		X	in Millivolts
40	X	X	X	X	X		X	LSD
1821					1	1		Blank
1822					1	1		Blank
1823					X	1	X	Sign
1824	X	X	X	X	X		X	MSD
1825	X	X	X	X	X		X	Attenuation Level
1826	X	X	X	X	X		X	LSD
1827	X	X	X	X	X		X	MSD
1828	X	X	X	X	X		X	Cal Phase on Cal Runs in Degrees
1829	X	X	X	X	X		X	LSD
1830					X	1	X	Sign
1831	X	X	X	X	X		X	MSD
1832	X	X	X	X	X		X	
1833	X	X	X	X	X		X	Pitch Angle in Tenths of Degrees
1834	X	X	X	X	X		X	
1835	X	X	X	X	X		X	
1836	X	X	X	X	X		X	LSD
1837					X	1	X	Sign
1838	X	X	X	X	X		X	MSD
1839	X	X	X	X	X		X	
1840	X	X	X	X	X		X	Roll Angle in Tenths of Degrees
1841	X	X	X	X	X		X	
1842	X	X	X	X	X		X	
1843	X	X	X	X	X		X	LSD
1844					X	1	X	Sign
1845	X	X	X	X	X		X	MSD
1846	X	X	X	X	X		X	
1847	X	X	X	X	X		X	Yaw, Azimuth, or Aspect In Tenths of Degrees
1848	X	X	X	X	X		X	
1849	X	X	X	X	X		X	
1850	X	X	X	X	X		X	LSD
	X	X	X	X	X	X	X	Longitudinal Parity
								3/4 inch gap
	1	1	1	1	1	1	1	Next Record

One Sample  
Repeated 1 to 128 times  
(90 for this application)  
Range increment per  
sample (in inches) to  
be marked on each reel

- Notes:  
1) All Recordings @  
556 BPI in BCD Code  
2)  Fixed Format Bits  
 Fixed Format Zero  
 Auto or Preset  
 Bit Changes  
 Data Bit Changes

Figure 3 MAGNETIC TAPE FORMAT

## 3.2 COMPUTER PROGRAM SUBROUTINE CHARACTERISTICS

This paragraph contains the detailed technical descriptions of the computer program subroutines identified in paragraph 3.1 of this specification. The instruction listings contained herein by inclusion or reference specify the exact configuration of SP3D. SP3D is written in FORTRAN Y language for use with the GE 635/645 computer system.

### 3.2.1 Executive Routine

The executive routine of SP3D is responsible for (1) reading and testing input data for tape and plot control, (2) acquiring and scaling data from tape, (3) determining if the tape is in dB or millivolts, and (4) writing header and trailer information obtained from the second record of each sweep onto a plot frame.

#### 3.2.1.1 Description of Executive Routine

Card input data to SP3D is tested for the correct range of values. If values are found to be outside their permissible range, they are either set to be within the permissible range or execution is halted depending on the variable being tested.

Generally, edited short-pulse magnetic tapes are expressed in millivolts; however, at times it has been desirable to have the amplitude data expressed in dB (relative to saturation). Therefore, FORTRAN logic has been implemented to detect whether tapes to be displayed are expressed in millivolts or dB. This is accomplished by testing the algebraic sign of the amplitude channel data in the first sweep of the first file. If the sign is positive, it indicates that the data is in millivolts; if negative, then the data is expressed in dB. The phase channels are always expressed in millivolts.

A scale factor of (1/500) is chosen when the amplitude response is in millivolts. This produces a maximum display of 20 units in amplitude for each radar signature. For the case in which the amplitude has been calibrated in dB, scaling is accomplished according to

$$\sigma_D = (\sigma_T + YTOP)$$

where

$\sigma_T$  = Amplitude response read from magnetic tape (in dB)

$\sigma_D$  = Scaled amplitude response for display

YTOP = User-selected scale factor

The constant, YTOP, is used to "mirror" all amplitude samples to magnitudes greater than zero and is entered into the program via punched cards. If, for example, it is desired to produce a 20 dB dynamic range display of the amplitude response, then the user should enter the value of 20.0 for YTOP. The resulting three-dimensional presentation will consist of analog traces of all amplitudes which were within 20 dB of saturation. Amplitudes which were of lesser magnitude will be displayed at the 20 dB threshold level.

In selecting a value for YTOP, the user should have knowledge of the threshold which was used when the amplitude data was calibrated. That is, if only that data which was within 25 dB of saturation was calibrated, then the value of YTOP should not exceed 25.0 when entered into SP3D. A violation of this practical limit would simply result in a 25 dB dynamic range display of the signatures.

The user of SP3D has, through card input to the executive routine, the option of displaying the scaled amplitude response only, or of displaying both the scaled amplitude response as well as the response which is computed through the use of the two phase components.

The phase response is displayed in the form of  $K_p \sqrt{\sigma_I^2 + \sigma_Q^2}$  where  $K_p$  has been arbitrarily chosen as (.707/500). The display of this data was made optional since it increases program run time by approximately 40-percent and may not be desired from each magnetic tape. In either case, the user is provided with a complete run log of the information contained on tape. This run log is printed on the plot frame next to the actual plot. This log is in the form of a listing of the header and trailer data obtained from the second record of each sweep. If desired, the user also has the option of skipping any file on tape.

AUTOFLOW CHART SET - PHO/SCL EXECUTIVE

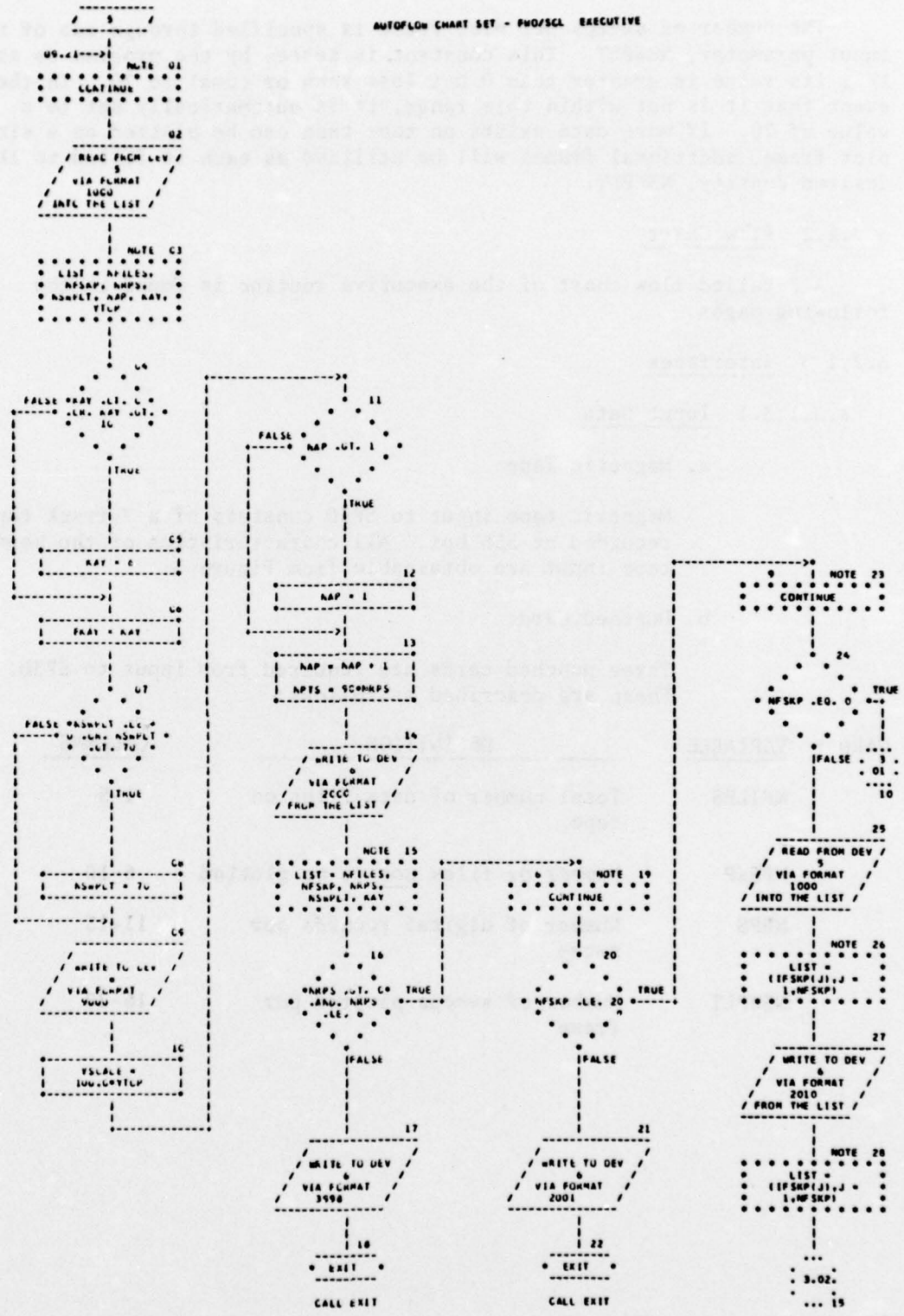

The number of sweeps per plot frame is specified through use of the input parameter, NSWPLT. This constant is tested by the program to assure that its value is greater than 0 but less than or equal to 70. In the event that it is not within this range, it is automatically set to a value of 70. If more data exists on tape than can be plotted on a single plot frame, additional frames will be utilized as each is filled to the desired density, NSWPLT.

### 3.2.1.2 Flow Chart

A detailed flow chart of the executive routine is found in the following pages.

### 3.2.1.3 Interfaces

#### 3.2.1.3.1 Input Data

##### a. Magnetic Tape:

Magnetic tape input to SP3D consists of a 7-track tape recorded at 556 bpi. All characteristics of the magnetic tape input are obtainable from Figure 3.

##### b. Punched Card:

Three punched cards are required from input to SP3D. These are described as follows:

CARD 1	<u>VARIABLE</u>	<u>DEFINITION</u>	<u>COLUMNS</u>
	NFILES	Total number of data files on tape	1-5
	NFSKP	Number of files <u>not</u> to be plotted	6-10
	NRPS	Number of digital records per sweep	11-15
	NSWPLT	Number of sweeps plotted per frame	16-20

AUTOFLOW CHART SET - FWD/SCL EXECUTIVE

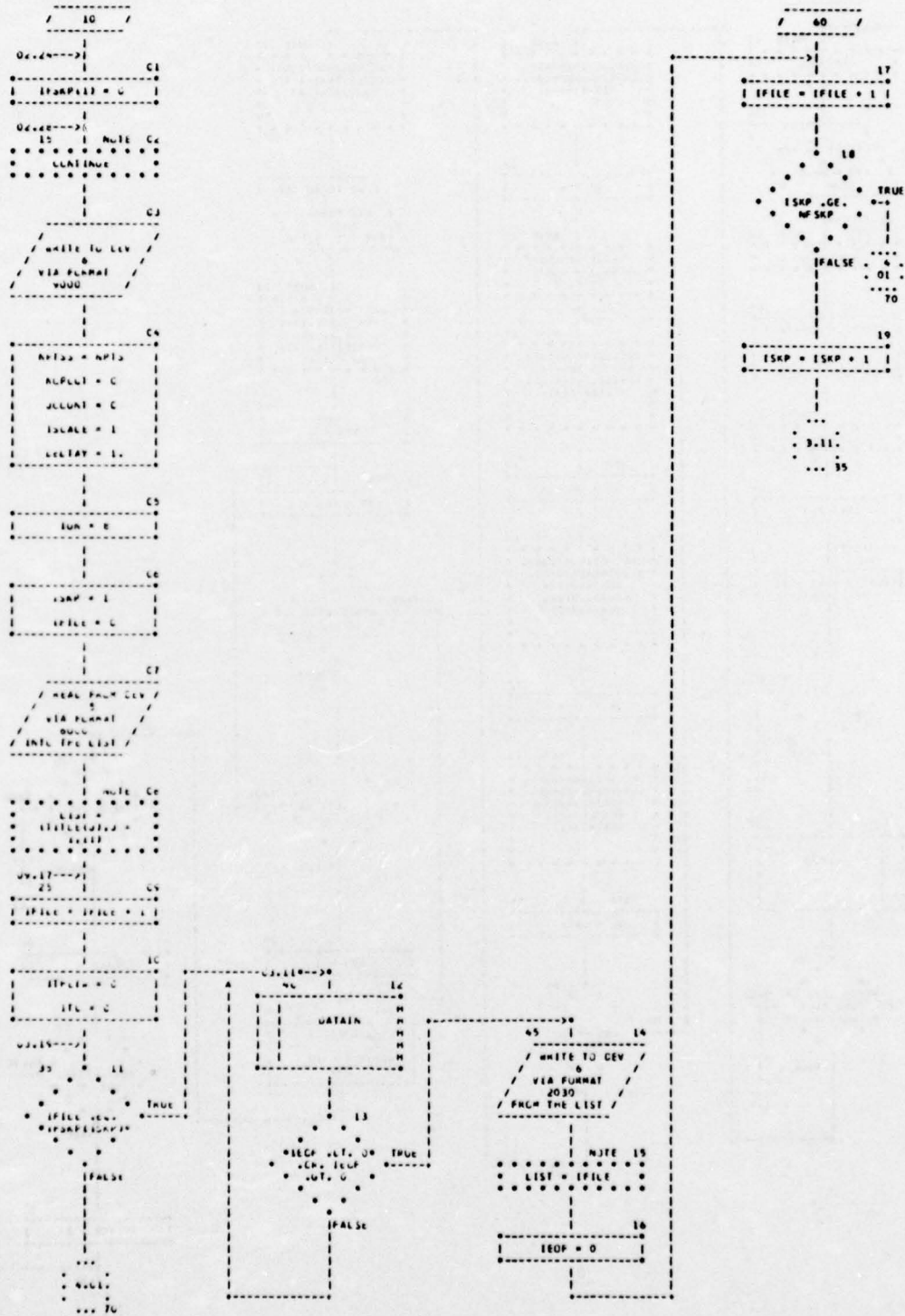

AUTOFLOW CHART SET - PW0/SCL EXECUTIVE

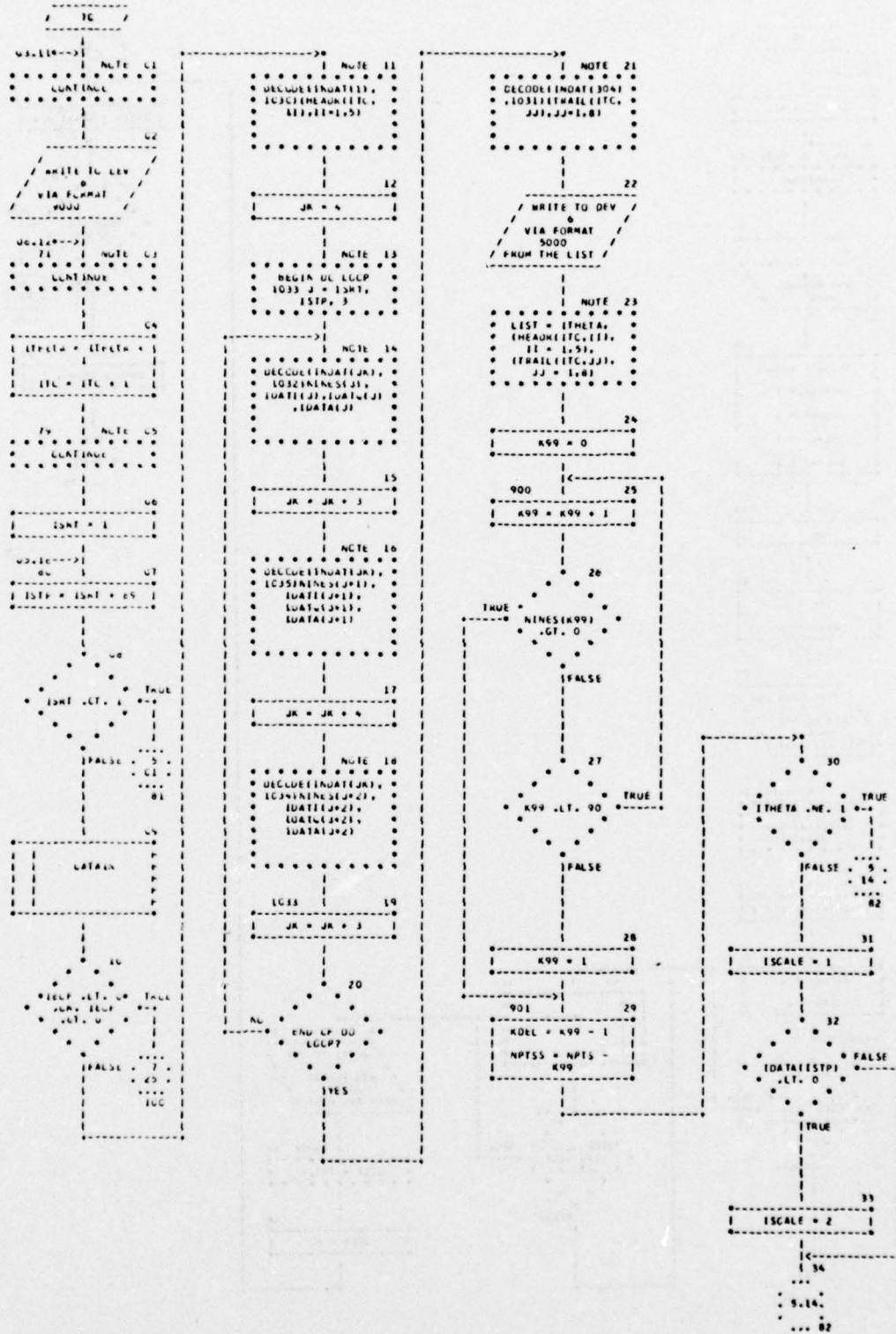

AUTOFLOW CHART SET - PWD/SCL EXECUTIVE

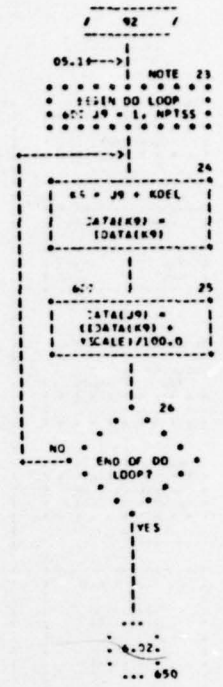
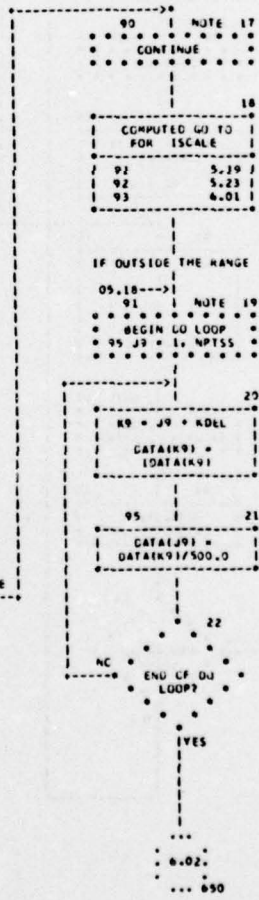
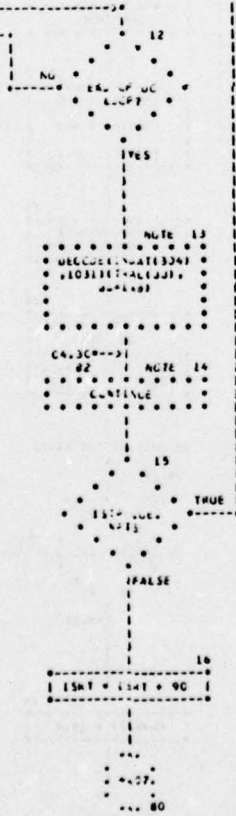
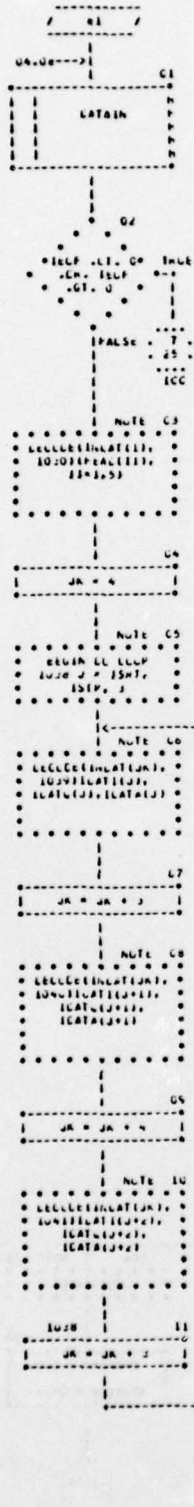

AUTOFLOW CHART SET - PRO/SCL EXECUTIVE

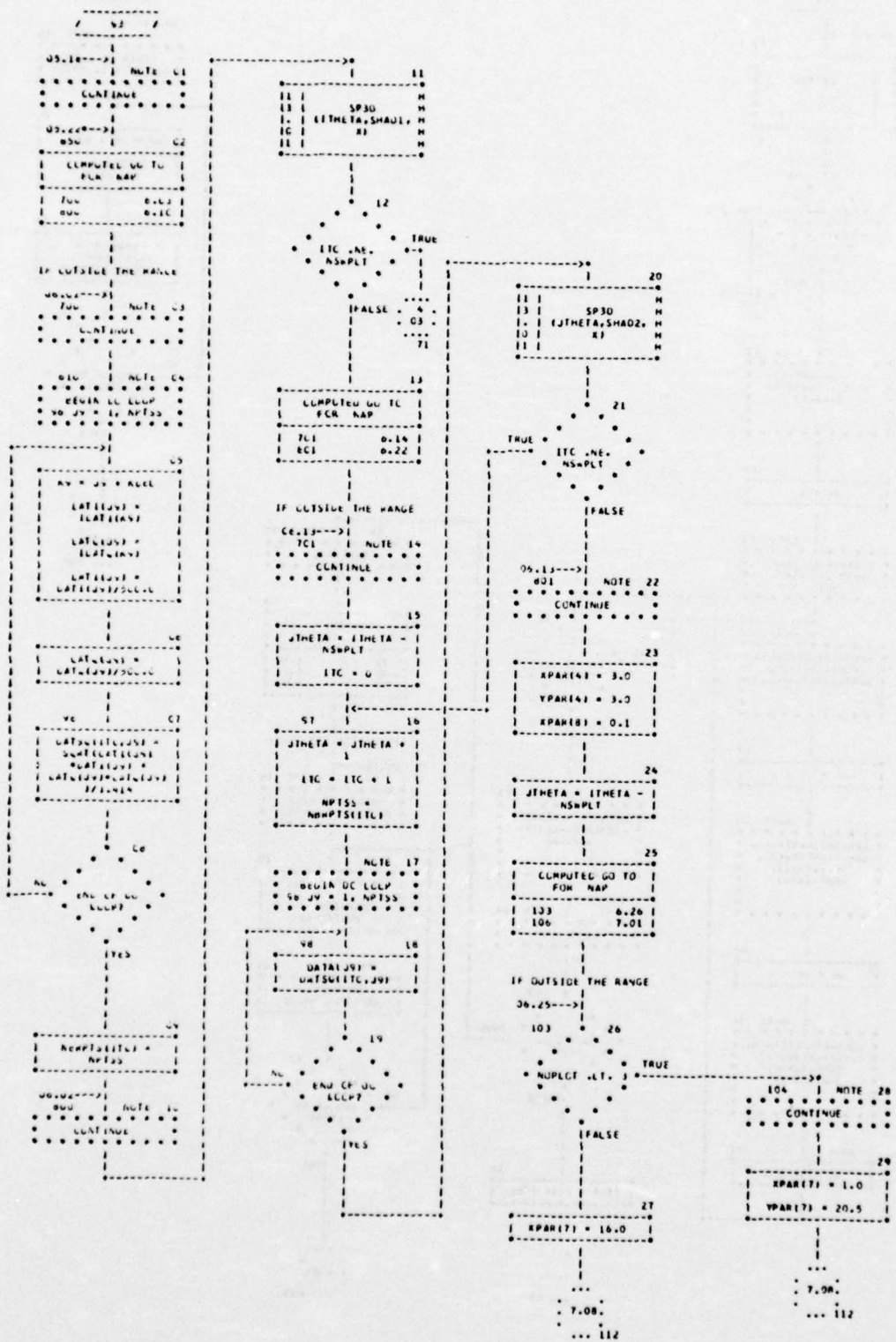

AUTOPLOM CHART SET - PNO/SCL EXECUTIVE

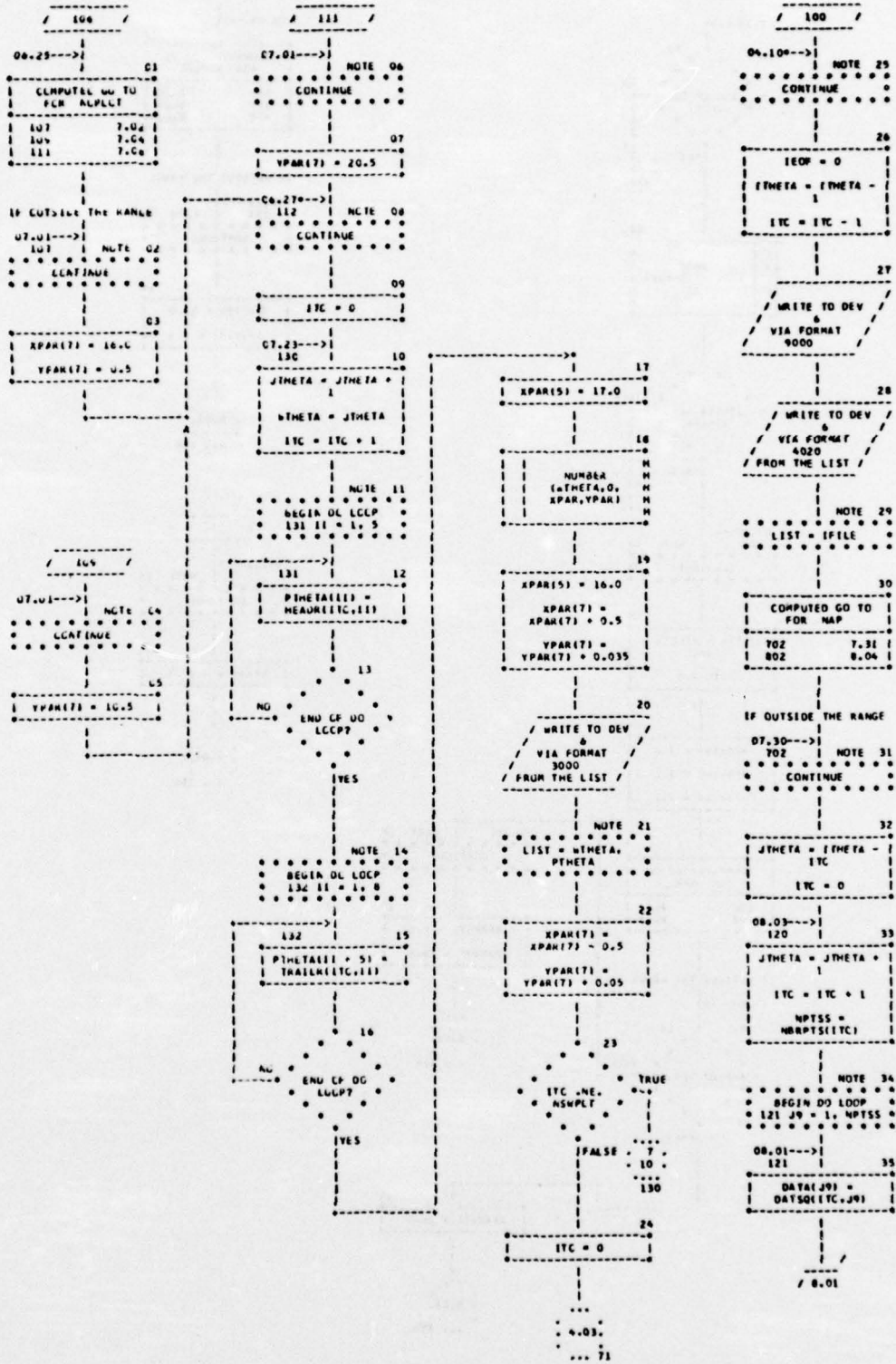

AUTOFLOW CHART SET - PNO/SCL EXECUTIVE

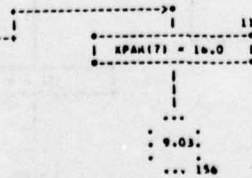
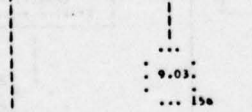
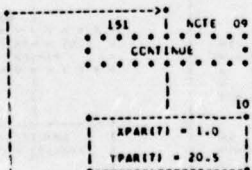
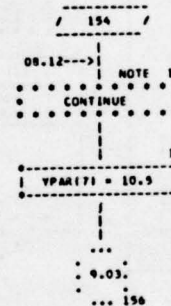
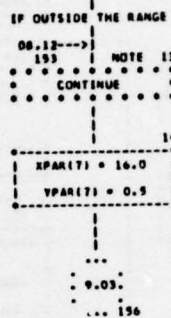
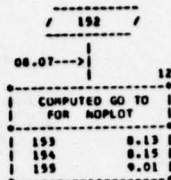
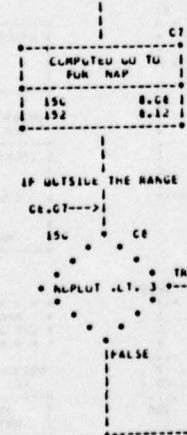
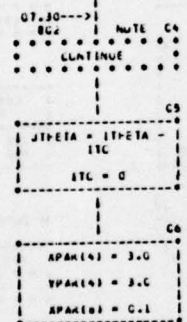
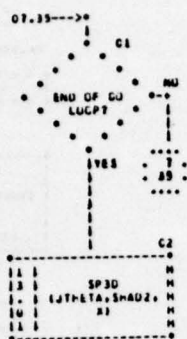

AUTOPLCN CHART SET - FNO/SCL EXECUTIVE

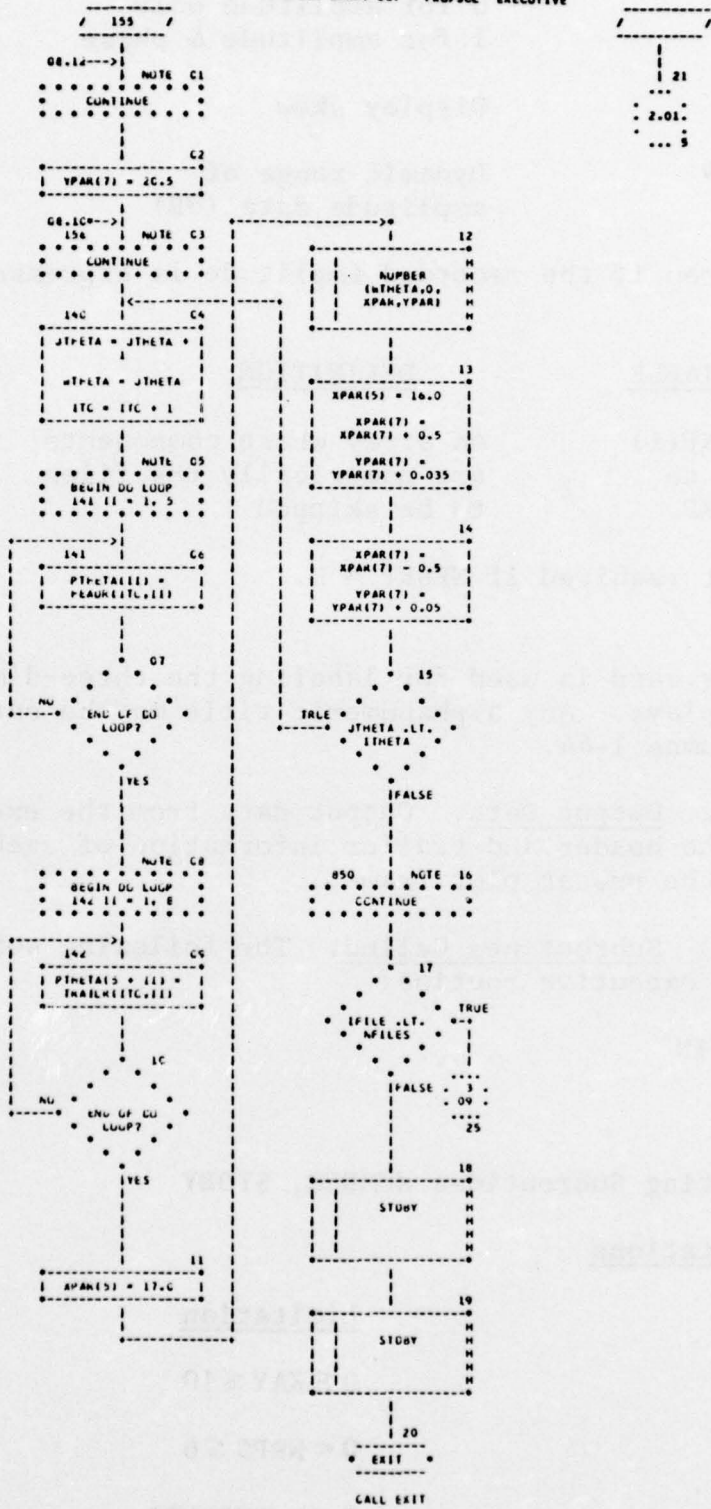

CARD 1	<u>VARIABLE</u>	<u>DEFINITION</u>	<u>COLUMNS</u>
	NAP	0 for amplitude only 1 for amplitude & phase	21-25
	KAY	Display skew	26-30
	*YTOP	Dynamic range of amplitude data (dB)	30-40

\*YTOP is ignored if the recorded amplitude is expressed in millivolts.

CARD 2	<u>VARIABLE</u>	<u>DEFINITION</u>	<u>COLUMNS</u>
	*IFSKP(i) i=1 to NFSKP	An array whose components are numerically the files to be skipped	1-5, 6-10, etc.

\*Card 2 is not required if NFSKP = 0.

CARD 3 This card is used for labeling the three-dimensional displays. Any alphanumeric title may be entered into Columns 1-44.

3.2.1.3.2 Output Data. Output data from the executive routine consists of the header and trailer information of each sweep being written onto the proper plot frame.

3.2.1.3.3 Subroutines Called. The following subroutines are called by the executive routine:

1. DATAIN
2. SP3D
3. Plotting Subroutines NUMBER, STDBY

#### 3.2.1.4 Limitations

<u>Variable</u>	<u>Limitation</u>
KAY	$0 \leq \text{KAY} \leq 10$
NRPS	$0 < \text{NRPS} \leq 6$
NFSKP	$0 \leq \text{NFSKP} \leq 20$
NSWPLT	$0 < \text{NSWPLT} \leq 70$

All fixed point variables on input must be right adjusted.

#### 3.2.1.5 Listing

A listing of the executive routine is found in the following pages.

### 3.2.2 Computer Program Subroutine SP3D

Subroutine SP3D has as its primary functions (1) the selection of points to be plotted and (2) skewing and plotting of the data. Subroutine SP3D is written in FORTRAN IV language for use with the GE 635/645 computer system at RADC.

#### 3.2.2.1 Description of Subroutine SP3D

In subroutine SP3D, all sweeps except for the first of each plot frame are shifted in the X and Y directions. The input variable KAY provides the horizontal displacement per unit vertical displacement.

The first sweep of each plot frame is plotted in its entirety. The points of each successive sweep are tested to see if they will be plotted. The criteria used for the selection is such that if the point under consideration (after being shifted) is less than or equal to the point immediately below it in the previous sweep then the point shall not be plotted. Figure 4 illustrates this technique in a blown up portion of a sweep. Plotting is accomplished by using standard RADC plotting routines.

#### 3.2.2.2 Subroutine SP3D Flow Chart

A detailed flow chart of subroutine SP3D is contained in the following pages.

#### 3.2.2.3 Interfaces

3.2.2.3.1 Input. Input to subroutine SP3D consists of (1) the variables in common blocks 1, 2, 3, 4 and (2) the variables ITHETA, SHADOW, and X which are transferred through the subroutine argument list.

3.2.2.3.2 Output. The output of subroutine SP3D consists of the three-dimensional plot of the radar signature data.

```

C      MAIN - SP3D 7090
COMMON/BLOCK1/NPTS,NPTSS,ITC,KAY,DELTAY,DATA(540)
COMMON /BLOC<2/ XU, YL, YU, TITLE(11)
COMMON /BLOC<3/ NOPLOT, FKAY, NAP
COMMON /BLOC<4/ XPAR(8), YPAR(8)
COMMON /BLOC<5/ X(600), SHAD1(600), SMAD2(600)
COMMON /INPUT/ INDAT(309),IEOF
DIMENSION IFSKP(20)
1 IDATI(540) , IDATO(540) , IDATA(540)
2 DATI(540) , DATQ(540) , DATSQ(70,540)

C
DIMENSION SHEADR(100,5) , TRAIL(100,8) , HEAD(5) , TRAL(8)

C
DIMENSION NINES(90) , NBRPTS(100)
DIMENSION PTHETA(13)

C
5 CONTINUE

C
READ (5,1010) NFILES, NFSK P, NRPS, NSWPLT, NAP, KAY , YTOP
1100 FORMAT ( 6I5,F10.0)
IF ( KAY .LT. .OR. KAY .GT. 10 ) KAY = 6
FKAY = KAY
IF( NSWPLT .LE. 0 .OR. NSWPLT .GT. 70 ) NSWPLT = 70
WRITE (6,9001)
YSCALE = 100.0* YTOP
IF( NAP .GT. 1 ) NAP = 1
NAP = NAP + 1
NPTS = 90*NRPS
WRITE (6,2000) NFILES, NFSKP, NRPS, NSWPLT , KAY
2100 FORMAT (10H NFILES = ,I3,10H NFSKP = ,I3,
1/ 10H NRPS = ,I3,10H NSWPLT = ,I3,
2/ 10H KAY = ,I3
3)
IF( NRPS .GT. .AND. NRPS .LE. 6 ) GO TO 6
WRITE (6,3998)
3998 FORMAT (25H NWDS NE TO 90,...,540 )
CALL EXIT
8 CONTINUE

C
IF( NFSKP .LE. 20)GO TO 9
WRITE (6,2001)
2001 FORMAT (15H NFSKP .GT. 20 )
CALL EXIT
9 CONTINUE

C
IF( NFSKP .EQ. 0 ) GO TO 10
READ (5,100 )( IFSKP(J),J=1,NFSKP )
WRITE (6,2010)( IFSKP(J),J=1,NFSKP )
2010 FORMAT (21H FILES TO BE SKIPPED , /, 1H ,10(2X,I5) )
GO TO 15
10 IFSKP(1) = 0

```

```

      15 CONTINUE
C
C      WRITE (6,9000)
9500  FORMAT(///)
C
C
C
C
      NPTSS = NPTS
      NOPLOT = 0
      JCOUNT = 0
      ISCALE = 1
      DELTAY = 1.
C
      IUN = 8
C
      ISKP = 1
      IFILE = 0
C
C
      30 READ (5,6000) ( TITLE(J),J=1,11 )
9000  FORMAT( 12A4 )
C
C
      25 IFILE = IFILE + 1
C
C
C
      ITHETA = 0
      ITC = 0
      35 IF( IFILE .EQ. IFSKP( ISKP ) ) GO TO 40
      GO TO 70
C
      40 CALL DATAIN
      IF (IEOF .LT. 0 .OR. IEOF .GT. 0) GO TO 45
      GO TO 40
C
C
      45 WRITE (6,2030) IFILE
9030  FORMAT (16H BYPASSED FILE * 12 )
      IEOF = 0
      GO TO 60
C
      60 IFILE = IFILE + 1
      IF( ISKP .GE. NFSKP ) GO TO 70
      ISKP = ISKP + 1
      GO TO 35
C
      70 CONTINUE
      WRITE (6,9000)

```

```

71 CONTINUE
   ITHETA = ITHETA + 1
   ITC=ITC+1
72 CONTINUE
   ISRT = 1
80 ISTOP = ISRT + 89
   IF( ISRT .GT. 1 ) GO TO 81
C
   CALL DATIN
   IF (IEOF .LT. 0 .OR. IEOF .GT. 0) GO TO 100
   DECODE(INDAT(1),1030)(HEADR(ITC,II),II=1,5)
1030 FORMAT(5A4)
   JK=4
   DO 1033 J=ISRT,ISTP,3
   DECODE(INDAT(JK),1032)NINES(J),IDATI(J),IDATQ(J),IDATA(J)
1032 FORMAT(2X,4I5)
   JK=JK+3
   DECODE(INDAT(JK),1035)NINES(J+1),IDATI(J+1),IDATQ(J+1),IDATA(J+1)
1035 FORMAT(4X,4I5)
   JK=JK+4
   DECODE(INDAT(JK),1034)NINES(J+2),IDATI(J+2),IDATQ(J+2),IDATA(J+2)
1034 FORMAT(4I5)
#1033 JK=JK+3
   DECODE(INDAT(3,4),1031)(TRAIL(ITC,JJ),JJ=1,8)
1031 FORMAT(4X,8A4)
   WRITE (6,5000) ITHETA,(HEADR(ITC,II),II=1,5),
1      (TRAIL(ITC,JJ),JJ=1,8)
5000 FORMAT ( 74 SWEEP(,I3, 7H ) ,5A4, 3X,8A4)
   K99 = 0
900 K99 = K99 + 1
   IF( NINES(K99) .GT. 0 ) GO TO 901
   IF( K99 .LT. 90 ) GO TO 900
   K99 = 1
901 KDEL = K99 - 1
   NPTSS = NPTS -K99
   IF ( ITHETA .NE. 1 ) GO TO 82
   ISCALE = 1
   IF (IDATA(ISTP) .LT. 0) ISCALE = 2
C
   GO TO 82
C
81 CALL DATIN
   IF (IEOF .LT. 0 .OR. IEOF .GT. 0) GO TO 100
   DECODE(INDAT(1),1030)(HEAD(II),II=1,5)
   JK=4
   DO 1038 J=ISRT,ISTP,3
   DECODE(INDAT(JK),1039) IDATI(J),IDATQ(J),IDATA(J)
1039 FORMAT(7X,3I5)
   JK=JK+3
   DECODE(INDAT(JK),1040) IDATI(J+1),IDATQ(J+1),IDATA(J+1)
1040 FORMAT(9X,3I5)
   JK=JK+4

```

```

1001 DECODE(INDAT(JK)71041)          IDATI(J+2), IDATQ(J+2), IDATA(J+2)
1008 FORMAT(5X,3I5)
1008 JK=JK+3
82 DECODE(INDAT(304),1081)(YRAL(JJ),JJ=1,8)
CONTINUE
IF( ISTEP .GE. NPTS ) GO TO 90
ISRT = ISRT + 90
GO TO 80
C
C
90 CONTINUE
GO TO (91,92,93); ISCALE
91 DO 95 J9 = 1,NPTS
K9 = J9 + 4DEL
DATA(K9) = IDATA(K9)
95 DATA(J9) = DATA(K9)/500.0
GO TO 650
C
92 DO 600 J9 = 1,NPTS
K9 = J9 + 4DEL
DATA(K9) = IDATA(K9)
600 DATA(J9) = (DATA(K9) + YSCALE)/100.0
GO TO 650
93 CONTINUE
C
650 CONTINUE
GO TO (700,800) ; NAP
C
700 CONTINUE
C
610 DO 96 J9 = 1,NPTS
K9 = J9 + 4DEL
DATI(J9) = IDATI(K9)
DATQ(J9) = IDATQ(K9)
DATI(J9) = DATI(J9)/500.0
DATQ(J9) = DATQ(J9)/500.0
96 DATSQ(ITC,J9) = SQRT(DATI(J9)*DATI(J9) + DATQ(J9)*DATQ(J9) )/1.414
NBRPTS(ITC) = NPTS
C
800 CONTINUE
C
C
CALL SP3D( ITHETA , SHAD1 , X )
C
IF( ITC .NE. NSWPLT ) GO TO 71
C
GO TO (701,801),NAP
C
701 CONTINUE
C
JTHETA = ITHETA - NSWPLT

```

```

      ITC = 0
97  JTHETA = JTHETA + 1
      ITC = ITC + 1
      NPTSS = NBRPTS(ITC)
      DO 98 J9=1,NPTSS
98  DATA(J9) = DATSQ(ITC,J9)
C
      CALL SP3D( JTHETA , SHAD2 , X )
C
C
      IF( ITC .NE. NSWPLT) GO TO 97
C
001 CONTINUE
C
C
      XPAR(4) = 3.0
      YPAR(4) = 3.0
      XPAN(8) = 0.1
C
      JTHETA = ITHETA - NSWPLT
      GO TO (103,106) ; NAP
103 IF (NOPLT .LT. 3) GO TO 104
      XPAR(7) = 16.
      GO TO 112
104 CONTINUE
      XPAR(7) = 1.0
      YPAR(7) = 20.5
      GO TO 112
106 GO TO (107,109,111) , NOPLT
107 CONTINUE
      XPAR(7) = 16.
      YPAR(7) = 0.5
      GO TO 112
109 CONTINUE
      YPAR(7) = 10.5
      GO TO 112
111 CONTINUE
      YPAR(7) = 20.5
112 CONTINUE
      ITC = 0
130 JTHETA = JTHETA + 1
      WTHETA = JTHETA
      ITC = ITC + 1
C
      DO 131 II = 1,5
131 PTHETA(II) = HEADR(ITC,II)
      DO 132 II = 1,8
132 PTHETA(II+3) = TRAIL(ITC,II)
      XPAR(5) = 17.
      CALL NUMBER (WTHETA ; , , XPAN , YPAR )
C
      XPAR(5) = 16.

```

```

XPAR(7) = XPAR(7) + 0.5
YPAR(7) = YPAR(7) + 0.035
C
WRITE (6,3000) WTHETA, PTHETA
8000 FORMAT (1H ,F5.175X,13A4 )
C
XPAR(7) = XPAR(7) - 0.5
YPAR(7) = YPAR(7) + 0.05
C
IF( ITC .NE. NSWPLT) GO TO 130
C
ITC = 0
GO TO 71
C
C
100 CONTINUE
IEOF = 0
ITHETA = ITHETA - 1
ITC = ITC + 1
WRITE (6,9000)
WRITE (6,4020) IFILE
4020 FORMAT (23H COMPLETED DATA FILE ( , 12H ) )
C
C
C
GO TO (702,802),NAP
702 CONTINUE
C
JTHETA = ITHETA - ITC
ITC = 0
120 JTHETA = JTHETA + 1
ITC = ITC + 1
NPTS8 = NBRPTS(ITC)
DO 121 J9=1,NPTS8
121 DATA(J9) = DATSQ(ITC,J9)
CALL SP3D( JTHETA , SHAD2 , X )
C
C
IF( JTHETA .LT. ITHETA ) GO TO 120
C
802 CONTINUE
C
JTHETA = ITHETA - ITC
ITC = 0
C
XPAR(4) = 3.0
YPAR(4) = 3.0
XPAR(8) = 0.1
GO TO (150,152) , NAP
150 IF (NOPLT .LT. 3) GO TO 151
XPAR(7) = 16.0
GO TO 156

```

```

151 CONTINUE
   YPAR(7) = 1.
   YPAR(7) = 2.5
   GO TO 156
152 GO TO (153,154, 155) ,NOPL0T
153 CONTINUE
   XPAR(7) = 16.
   YPAR(7) = 0.5
   GO TO 156
154 CONTINUE
   YPAR(7) = 10.5
   GO TO 156
155 CONTINUE
   YPAR(7) = 20.5
156 CONTINUE
140 JTHETA = JTHETA + 1
   WTHETA = JTHETA
   ITC = ITC + 1
C
DO 141 II = 1,5
141 PTHETA(II) = HEADR(ITC,II)
DO 142 II = 1,8
   I1 = 5 + II
142 PTHETA(I1) = TRAIL(ITC,II)
   XPAR(5) = 17.
C
CALL NUMBER (WTHETA, ITC, XPAR, YPAR )
C
XPAR(5) = 16.
XPAR(7) = XPAR(7) + 0.5
YPAR(7) = YPAR(7) + 0.035
WRITE (6,3000) WTHETA, PTHETA
C
XPAR(7) = XPAR(7) - 0.5
YPAR(7) = YPAR(7) + 0.05
C
IF( JTHETA .LT. ITHETA ) GO TO 140
C
850 CONTINUE
C
IF( IFILE .LT. NFILES ) GO TO 25
C
C
C
CALL STDBY
CALL STDBY
CALL EXIT
GO TO 5
C
END
BLOCK DATA
COMMON /BLCK4/ XPAR(8), YPAR(8)

```

```
DATA XPAR / 3.0, 29.0, 170, 1.0, 16.0, 0.0, 12.0, 0.3 /  
DATA YPAR / 3.0, 29.0, 0.5, 1.0, 12.0, 0.0, 16.1, 0.0 /
```

```
END  
SUBROUTINE SP3D( ITHETA, SHADOW, X  
COMMON/BLOCK1/NPTS,NPTSS,ITC,KAY,DELTAY,DATA(540)  
COMMON /BLOCK2/ XU, YL, YU, TITLE(11)  
COMMON /BLOCK3/ NOPLT, PKAY, NAP  
COMMON /BLOCK4/ XPAR(8), YPAR(8)
```

```
C  
C DIMENSION X(600), YY(600), SHADOW(600), DATA(600)
```

```
ITHETA = ITHETA - 1  
IF( ITC .NE. 1 ) GO TO 40  
L1 = NPTSS + 1  
L2 = NPTS + 10  
DO 20 L = 1, L2  
A2 = L - 1  
X(L) = A2 * 0.01  
SHADOW(L) = DATA(L) * ITHETA * DELTAY
```

```
20 CONTINUE  
NOPLT = NOPLT + 1  
21 IF (NOPLT .NE. 1) GO TO 22  
WRITE (6,1000) TITLE
```

```
1000 FORMAT (11A4)  
22 CONTINUE  
GO TO (23,31), NAP
```

```
23 GO TO (26,27,28, 27,29), NOPLT  
26 XPAR(4) = 100.0  
YPAR(4) = 20.0  
GO TO 36
```

```
27 YPAR(3) = 10.5  
GO TO 36
```

```
28 XPAR(3) = 16.0  
YPAR(3) = 0.5  
XPAR(4) = 100.0  
YPAR(4) = 20.0  
GO TO 36
```

```
29 CALL STDBY  
YPAR(3) = 0.5  
XPAR(4) = 1.0  
YPAR(4) = 1.0  
XPAR(7) = 12.0  
YPAR(7) = 0.1  
XPAR(8) = 0.3  
NOPLT = 1  
GO TO 21
```

```
C  
31 GO TO (26,33,34,35), NOPLT  
33 YPAR(3) = 10.5  
GO TO 26  
34 YPAR(3) = 20.5  
GO TO 26
```

```

35 CALL STDBY
   YPAR(3) = 0.5
   YPAR(4) = 1.0
   YPAR(4) = 1.0
   XPAR(7) = 12.0
   YPAR(7) = 0.1
   XPAR(8) = 0.3
   NOPLOT = 1
   GO TO 21
C
C
36 CONTINUE
   LPTS = NPTSS - 1
C
   CALL LINE ( X, SHADOW , LPTS, XPAR, YPAR)
   DO 37 L = L1, L2
   SHADOW(L) = 0.
   A2 = L - 1
   X(L) = A2 * 0.01
30 CONTINUE
   RETURN
C
40 CONTINUE
   L2 = NPTS + 1
   DO 41 L = 1, L2
   X(L) = X(L) + FKAY*0.01
41 CONTINUE
   IRJJ = 0
   IR = 0
   DELTA = FT*ETA * DELTAY
50 CONTINUE
   ICTJ = 0
   ICTK = 0
   IR = IR + 1
   DATAC(IR) = DATA(IR) + DELTA
   IR1 = IR + KAY
   IF ( DATAC(IR) .LT. SHADOW(IR1) ) GO TO 60
   ICTK = 0
   IRJJ = IR
100 ICTK = ICTK + 1
   YY(IR) = DATAC(IR)
   SHADOW(IR) = YY(IR)
   IF( IR .GE. NPTSS) GO TO 60
   IR = IR + 1
   DATAC(IR) = DATA(IR) + DELTA
   IR1 = IR + KAY
   IF ( DATAC(IR) .GE. SHADOW(IR1) ) GO TO 100
60 ICTJ = ICTJ + 1
   IF ( ICTJ .EQ. 1 .AND. ICTK .GT. 1 ) GO TO 70
   GO TO 91
70 IRADJ = IRJJ - 1
   DO 81 IJK = 1, ICTK

```

```

      IJK1 = IR * KAY
      YY(IJK) = VY(IJK1)
      X(IJK) = X(IJK1)
90 CONTINUE
      LPTS = ICTK - 1
      CALL LINE 6 X, YY, LPTS, XPAR, YPAR)
      DO 90 IJK * 1, ICTK
      A1 = IJK-1 * (ITC - 1) * KAY
      X(IJK) = A1 * 0.01
90 CONTINUE
91 CONTINUE
      IF( IR .LT. NPTSS) GO TO 110
      GO TO 120
120 IR1 = IR * KAY
      SHADOW(IR) = SHADOW(IR1)
      GO TO 50
120 RETURN
      END

```

	SYMDEF	DATAIN
	BLOCK	INPJT
INDAT	BSS	309
IEBF	BSS	1
	USE	PREVIOUS
DKMAIN	SAVE	
	LDA	DCW1
	STA	DCW
	MME	GEINOS
	RTD	
	ZERO	FA, DCW
	ZERO	STATR
	MME	GEROAD
	LDA	STATR
	ANA	=3070000000000
	CMPA	=0040000000000
	TZE	EOF
	LDA	=0, DL
	TRA	RETURN
EOF	LDA	=1, DL
REYORN	STA	EOF
	RETURN	DATAIN
FA	BCI	1,000008
STATR	BSS	2
DCW	IOTD	INDAT, 309
DCW	BSS	1
	END	

```

      3      1      6      7      0      6
      1
      BR3D TAPE TEST

```

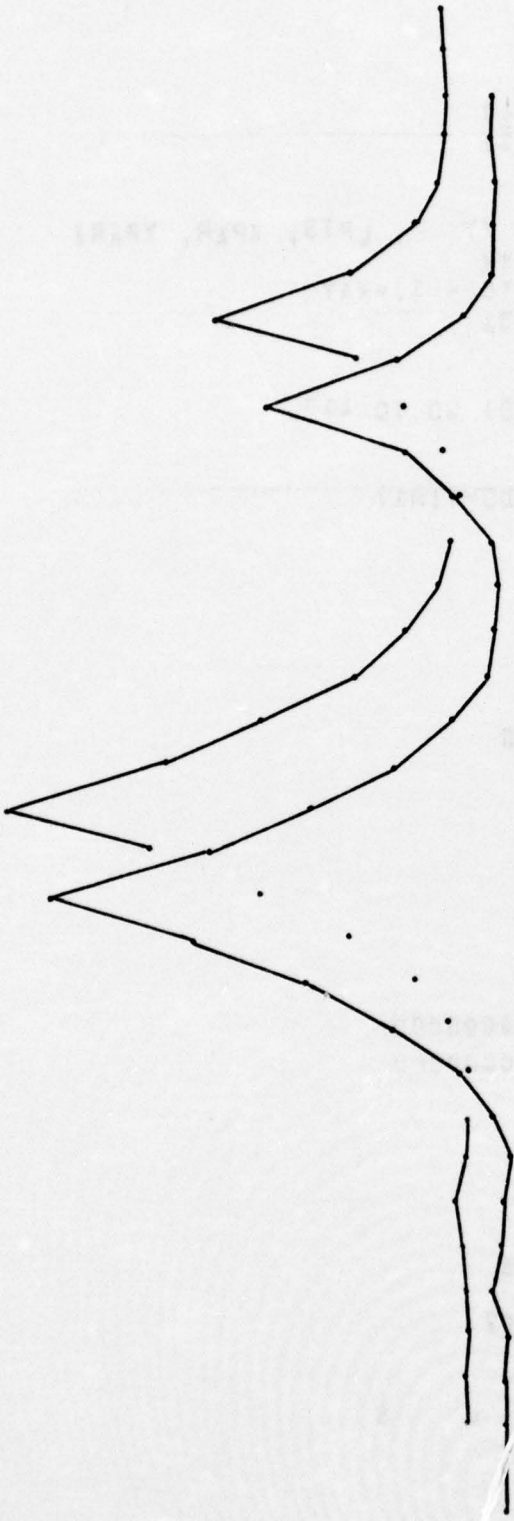
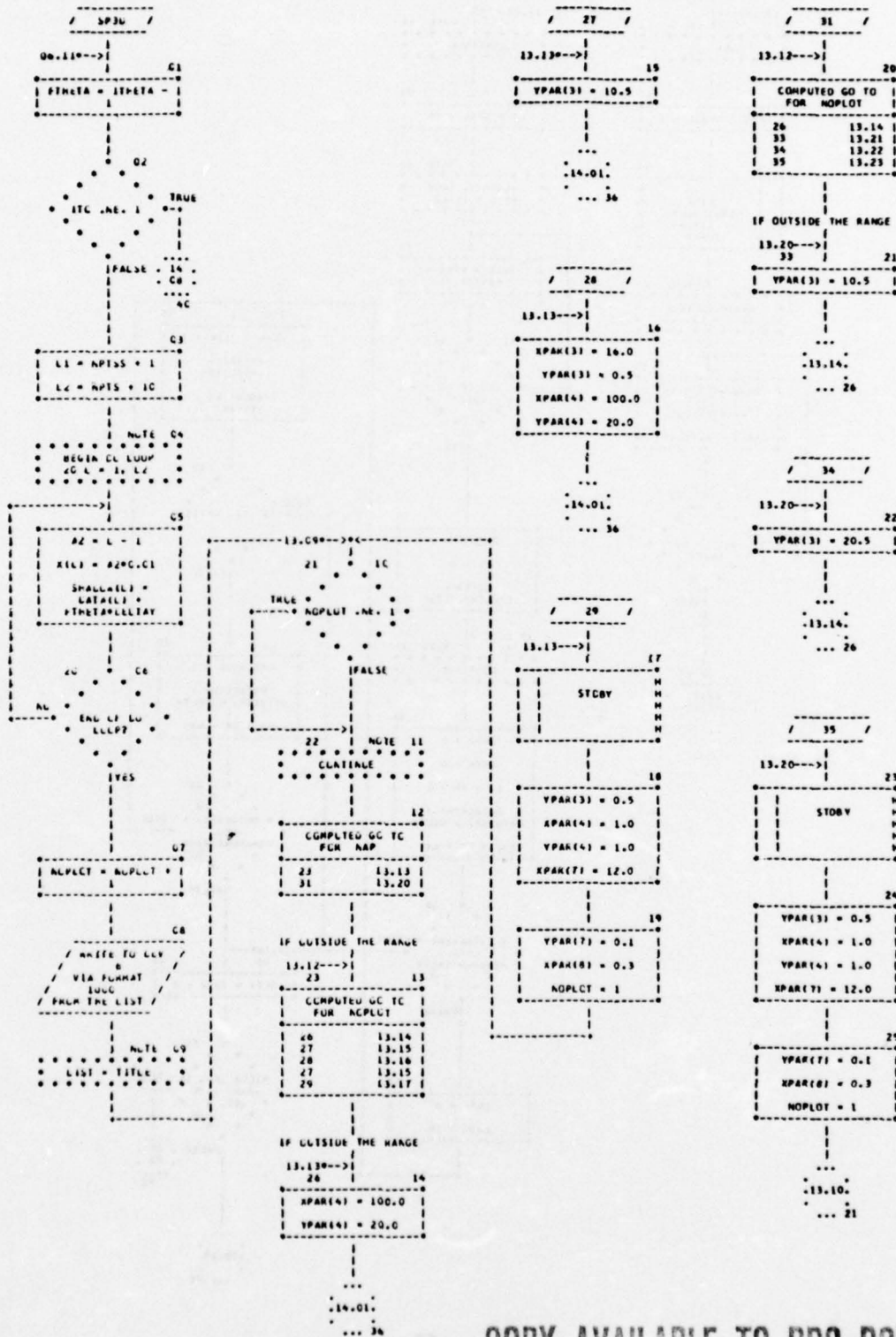
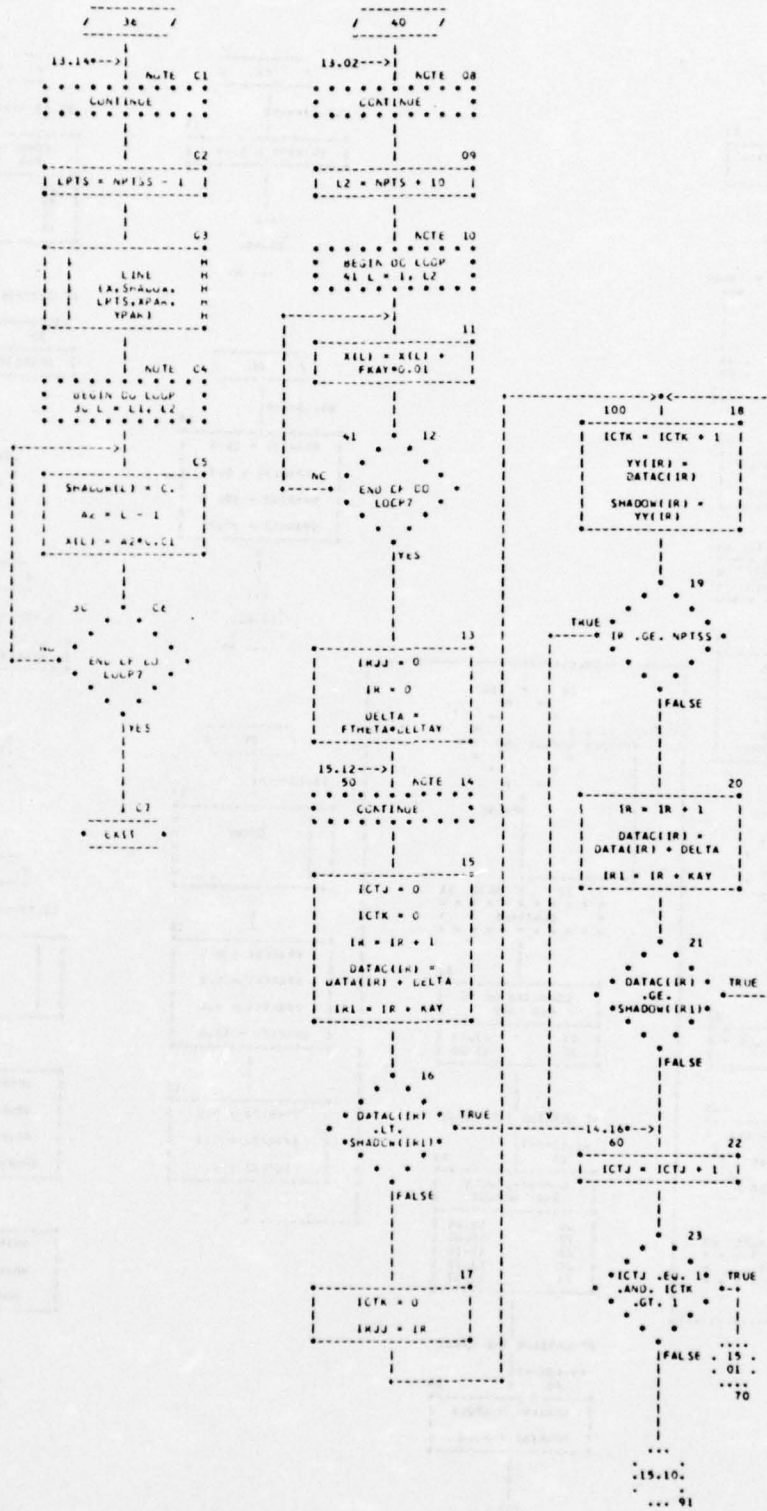

Figure 4 SP3D SHADOWING TECHNIQUE

CHART TITLE - SUBROUTINE SP30(IHETA,SHADCB,X)



COPY AVAILABLE TO DDC DOES NOT PERMIT FULLY LEGIBLE PRODUCTION



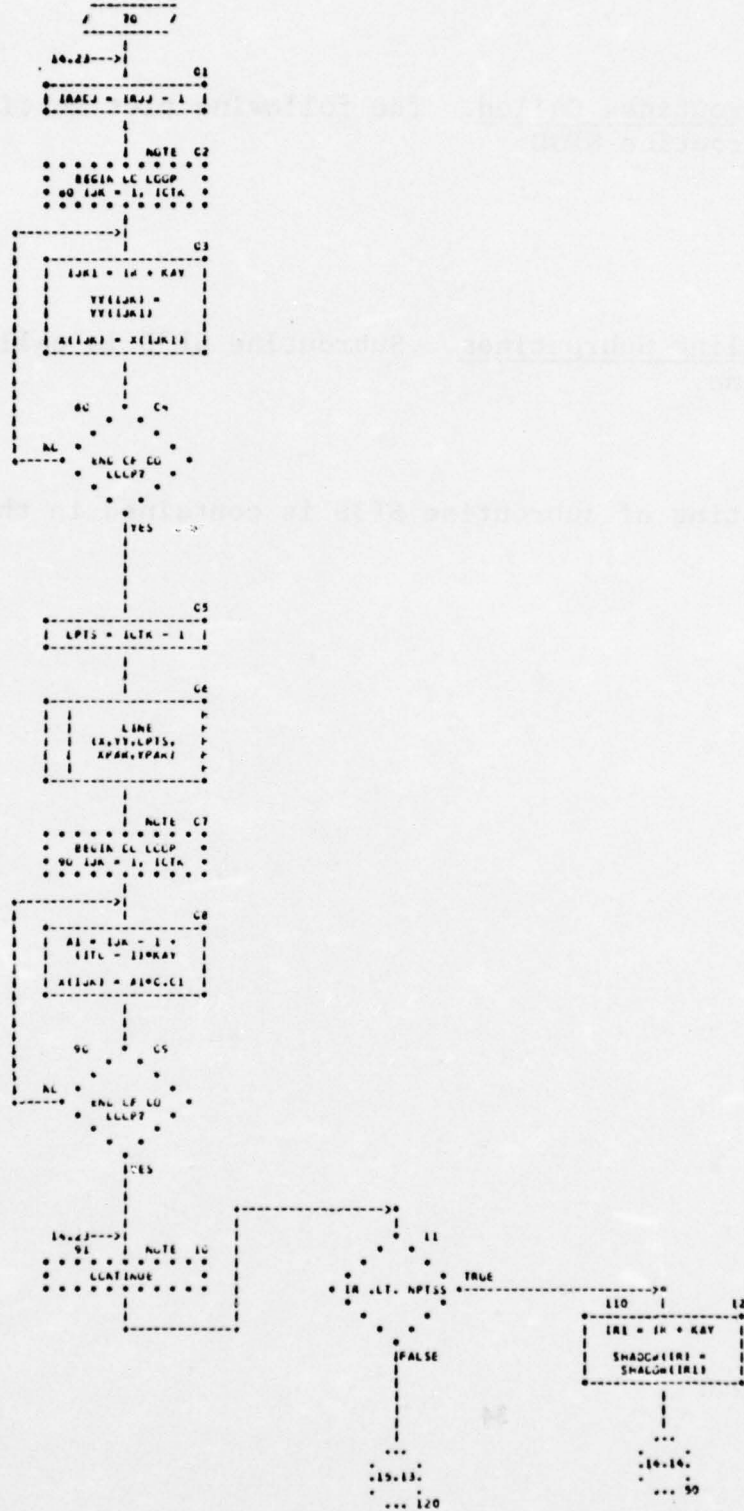

3.2.2.3.3 Subroutines Called. The following plot routines are called from subroutine SP3D:

1. STDBY
2. LINE

3.2.2.3.4 Calling Subroutines. Subroutine SP3D is called by the executive routine.

3.2.2.4 Listing

A complete listing of subroutine SP3D is contained in the following pages.

1-19-72 16,764

```

SUBROUTINE SP3D( ITHETA ,SHADOW ,X )
COMMON/BLOCK1/NPTS,NPTSS,ITC,KAY,DELTAY,DATA(54)
COMMON /BLOCK2/ XU, YL, YU, TITLE(11)
COMMON /BLOCK3/ NOPLOT, FKAY, NAP
COMMON /BLOCK4/ XPAR(8), YPAR(8)
C
DIMENSION X(600) , YY(600) ,SHADOW(610) ,DATA(600)
C
FTHETA = ITHETA - 1
IF( ITC .NE. 1 ) GO TO 40
L1 = NPTSS + 1
L2 = NPTS + 10
DO 20 L = 1,L2
A2 = L - 1
X(L) = A2 * 0.01
SHADOW(L) = DATA(L) + FTHETA * DELTAY
20 CONTINUE
NOPLOT = NOPLOT + 1
21 IF (NOPLOT .NE. 1) GO TO 22
WRITE (6,1000) TITLE
1000 FORMAT (11A4)
22 CONTINUE
GO TO (23,31) , NAP
23 GO TO (26,27,28, 27,29), NOPLOT
26 XPAR(4) = 100.0
YPAR(4) = 20.0
GO TO 36
27 YPAR(3) = 10.5
GO TO 36
28 XPAR(3) = 16.0
YPAR(3) = 0.5
XPAR(4) =100.0
YPAR(4) =20.0
GO TO 36
29 CALL STDRY
YPAR(3) = 0.5
XPAR(4) = 1.0
YPAR(4) = 1.0
XPAR(7) = 12.0
YPAR(7) = 0.1
XPAR(8) = 0.3
NOPLOT = 1
GO TO 21
31 GO TO (26,33,34,35), NOPLOT
33 YPAR(3) = 10.5
GO TO 26
34 YPAR(3) = 20.5
GO TO 26
35 CALL STDRY
YPAR(3) = 0.5

```

1-19-72 16.764

```

      XPAR(4) = 1.0
      YPAR(4) = 1.0
      XPAR(7) = 12.0
      YPAR(7) = 0.1
      XPAR(8) = 0.3
      NOPLOT = 1
      GO TO 21
C
C
36 CONTINUE
   LPTS = NPTS - 1
C
   CALL LINE ( X, SHADOW , LPTS, YPAR, YPAR)
   DO 30 L = L1, L2
   SHADOW(L) = 0.
   A2 = L - 1
   X(L) = A2 * 0.01
30 CONTINUE
   RETURN
C
40 CONTINUE
   L2 = NPTS + 10
   DO 41 L = 1, L2
   X(L) = X(L) + FKAY*0.01
41 CONTINUE
   IRJJ = 0
   IR = 0
   DELTA = FTHETA * DELTAY
50 CONTINUE
   ICTJ = 0
   ICTK = 0
   IR = IR + 1
   DATAC(IR) = DATA(IR) + DELTA
   IR1 = IR + KAY
   IF ( DATAC(IR) .LT. SHADOW(IR1) ) GO TO 60
   ICTK = 0
   IRJJ = IR
100 ICTK = ICTK + 1
   YY(IR) = DATAC(IR)
   SHADOW(IR) = YY(IR)
   IF( IR .GE. NPTS) GO TO 60
   IR = IR + 1
   DATAC(IR) = DATA(IR) + DELTA
   IR1 = IR + KAY
   IF ( DATAC(IR) .GE. SHADOW(IR1) ) GO TO 100
60 ICTJ = ICTJ + 1
   IF ( ICTJ .EQ. 1 .AND. ICTK .GT. 1 ) GO TO 70
   GO TO 91
70 IRADJ = IRJJ - 1
   DO 80 IJK = 1, ICTK
   IJK1 = IR + KAY
   YY(IJK) = YY(IJK1)

```

L-19-72 16.764

```
X(IJK) = X(IJK1)
CONTINUE
LPTS = ICTK - 1
CALL LINE ( X, YY, LPTS, XPAR, YPAR)
DO 90 IJK = 1, ICTK
A1 = IJK-1 + (ITC - 1)*KAY
X(IJK) = A1 * 0.01
90 CONTINUE
91 CONTINUE
IF( IR .LT. NPTSS) GO TO 110
GO TO 120
110 IR1 = IR + KAY
SHADOW(IR) = SHADOW(IR1)
GO TO 50
120 RETURN
END
```

WORDS OF MEMORY USED BY THIS COMPILATION

### 3.2.3 Computer Program Subroutine DATAIN

Subroutine DATAIN is written in GE Assembly Language for use with program SP3D.

#### 3.2.3.1 Description of Subroutine DATAIN

The standard magnetic tape record length for General Dynamics radar range data is 1852 BCD characters. This record length exceeds the allowable length for a FORTRAN read in GE FORTRAN IV language. DATAIN was written to allow data with this record length to be read from magnetic tape and stored in the array INDAT.

#### 3.2.3.2 Interfaces

3.2.3.2.1 Input. Input to DATAIN consists of data contained on magnetic tape.

3.2.3.2.2 Output. Data read from magnetic tape are placed in the array INDAT.

#### 3.2.3.3 Listing

A listing of DATAIN may be found in the following pages.

0	IDENT	BECAVJ01,HANCOCK ,651211040063,TAPEIN	
0	GMAP	LSTOU,SYAB,DECK,SYMTAB	
5	LIMITS	05,20K,0,5K	
5	RRMFL	C*,W,L,9ECAVU0170TAPIN	
	SYMDEF	DATAIN	
	BLOCK		BLANK COMMON
INDAT	BSS	309	BUFFER AREA
IPEF	BSS	1	CHAR/WORD XMITTAL STATUS
STATW	BSS	2	STATUS RETURN WORD
IERR	BSS	1	ERROR RETURN TO CALLING PROGRAM
	USE	PREVIOUS	
DATAIN	SAVE		ENTRY POINT
	LDA	DCW1	
	STA	DCW	
	LDA	=-2	
	STA	STATR	
	MME	GEINOS	
	RTD		
	ZERO	FA,DCW	FILE CODE WORD, DATA CONTROL WORD
	ZERO	STATR	STATUS RETURN WORD
	MME	GEROAB	
	LDAQ	STATR	
	STAQ	STATW	
	ANA	=0070000,DU	
	TZE	ERRF	NO ERRORS DETECTED BY TAPE CONTR
	CMPA	=0040000,DU	
	TZE	EOF	END OF FILE DETECTED
	CMPA	=0030000,DU	
	TZE	DALRT	DATA ALERT DETECTED
	LDA	=4,DL	
	TRA	ERRF	UNKNOWN ERROR DETECTED
EOF	LDA	=1,DL	END OF FILE
EXIT	STA	IERR	
	TRA	RTURN	
DALRT	LDA	STATR	DATA ALERT
	ANA	=0007700,DU	
	CMPA	=0000200,DU	TEST FOR BLANK TAPE ON READ
	TNZ	PCK	
	LDA	=16,DL	
	TRA	EXIT	
PCK	ANA	=0001000,DU	
	TNZ	LATPC	LONGITUDINAL PARITY CHECK
	LDA	=2,DL	
	TRA	ERRF	LATERAL PARITY CHECK
LATPC	LDA	=3,DL	
ERRF	STA	IERR	
	ANQ	=0707777,DL	TEST RECORD LENGTH READ
	STQ	IPEF	CHAR/WORD REMAINING TO XFER
	TZE	TEST3	
	LLS	21	A=NUMBER OF CHAR IN LAST WORD
	QRS	21	Q=NUMBER OF WORDS NOT XMITTED
	CMPQ	=1,DL	

	YZE	SREC	Q=1;ZERO=1
	TNC	CARCK	Q<1;CARRY=0
	LDQ	=20,DL	SHORT REC- MORE THAN 1 WORD DEFECTIVE
CARCK	TRA	ENDE	
	EMPA	=2,DL	
	LDA	IERR	
	TNC	SREC	A<2;CARRY=0
TESTJ	EMPA	=3,DL	
	TNZ	CHTL	A NOT* 3;ZERO=0
	LDA	=0,DL	
	STA	IERR	
	TRA	CHTL	
SREC	LDQ	=10,DL	SHORT RECORD-LAST WORD DEFECTIVE
ENDE	ASQ	IERR	COMBINE REC. LENG, TEST WITH IOC STAT.
CHTL	LDX0	=0,DU	CHARACTER TRANSLATE + AND = SIGNS
NWORD	EMPX0	=309,DU	BEGINNING OF WORD LOOP
	YZE	RTURN	
	LDA	INDAT,0	X0 IS INDEX REGISTER
	LDX1	=6,DU	
	LDQ	=0777777777700	
TESTC	WOP		BEGINNING OF CHAR. LOOP
	CMK	=013,DL	TEST RIGHT MOST CHAR FOR =
	YZE	EQUAL	
	CMK	=032,DL	TEST RIGHT MOST CHAR FOR +
	YZE	PLUS	
ROVAT	ALR	6	
	SBX1	=1,DU	
	TNZ	TESTC	END OF CHAR. LOOP
	STA	INDAT,0	
	ADX0	=1,DU	
	TRA	NWORD	END OF WORD LOOP
EQUAL	ERA	=0000066,DL	CORRECT = SIGN
	TRA	ROVAT	
PLUS	ERA	=0000052,DL	CORRECT + SIGN
	TRA	ROVAT	
RTURN	RETURN	DATAIN	RETURN TO CALLING PROGRAM
FA	BCI	1,000013	
STATR	EBSS	2	
DCW1	!OTD	INDAT,309	BUFFER ARRAY, NUMBER OF WORDS XMITTED
DCW	BSS	1	
	END		
S	ENDJOB		

S E C T I O N 4

T E S T D E S C R I P T I O N

A test problem was run on the GE 635/645 computer for the purposes of debugging computer program DISCRM. A description of the test problem is presented in the following paragraphs.

4.1 INPUT DATA

A listing of the values of the variables read from card input is found below. The format of the card input data and the definition of the variables may be found in Section 3.2.1.3.

CARD 1

<u>VARIABLE</u>	<u>VALUE</u>
NFILES	3
NFSKP	1
NRPS	6
NSWPLT	70
NAP	0
KAY	6
YTOP	0.0

CARD 2

<u>VARIABLE</u>	<u>VALUE</u>
IFSKP(1)	1

CARD 3

<u>VARIABLE</u>	<u>VALUE</u>
TITLE	SP3D Test Tape

A test tape was generated for the purpose of debugging this program. The tape format is described in Section 3.1.4. The tape contains 3 files; two of which contain data. It is standard practice to place an end-of-file mark on magnetic tapes produced on the radar range at the Fort Worth Operation, therefore, this end-of-file mark must always be skipped to reach the data files.

#### 4.2 OUTPUT DATA

The output for the sample problem may be found in the following pages. After bypassing the end-of-file mark, the header and trailer information of the first record of each sweep is printed as it is read. A second listing identical to the first but produces as the data are being plotted follows the first listing. A plot of the data produces on the RADC plotter is not available due to plotter problems, however, a plot of the second data file as produced at General Dynamics is provided.



6505 1240 0000.01 150000+100000+000000+000000+000010

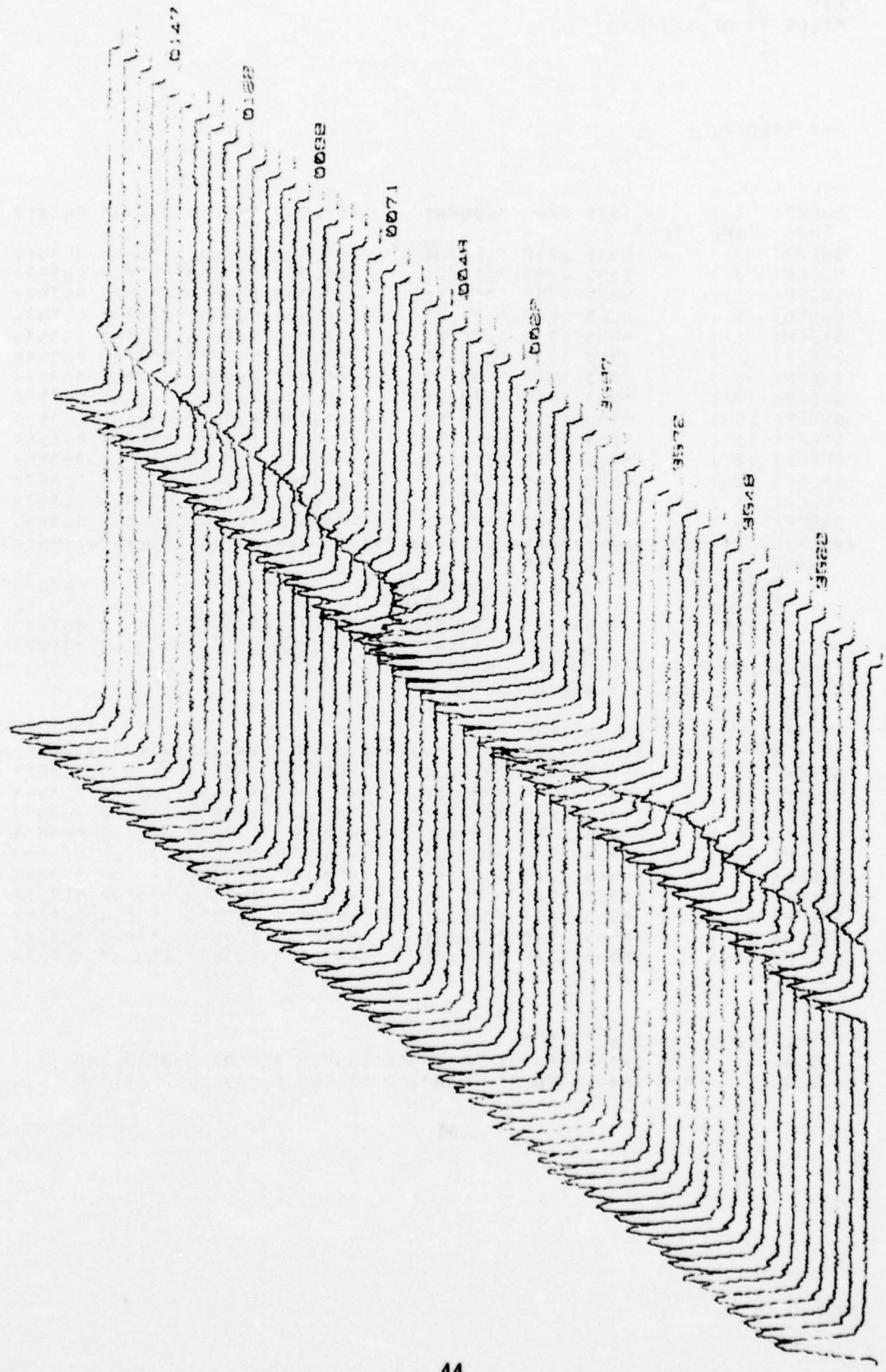

0147

0100

0099

0071

0044

0020

3547

3572

3548

3522

6505 1240 0000.01 150000+100000+000000+000000+000488



SWEEP ( 25 ) 6505 1240 0114/01 -150000 000000 000000 000000

COMPLETED DATA FILE ( 2 )

1.0	6505	1240	1000/01	-150000	100000	000000	0035460	00
2.0	6505	1240	1006/01	-150000	100000	000000	0038294	00
3.0	6505	1240	1012/01	-150000	100000	000000	0038490	00
4.0	6505	1240	1018/01	-150000	100000	000000	0038504	00
5.0	6505	1240	1024/01	-150000	100000	000000	0038518	00
6.0	6505	1240	1030/01	-150000	100000	000000	0038532	00
7.0	6505	1240	1036/01	-150000	100000	000000	0038546	00
8.0	6505	1240	1042/01	-150000	100000	000000	0038560	00
9.0	6505	1240	1048/01	-150000	100000	000000	0038574	00
10.0	6505	1240	1054/01	-150000	100000	000000	0038588	00
11.0	6505	1240	1060/01	-150000	100000	000000	0038602	00
12.0	6505	1240	1066/01	-150000	100000	000000	0038616	00
13.0	6505	1240	1072/01	-150000	100000	000000	0038630	00
14.0	6505	1240	1078/01	-150000	100000	000000	0038644	00
15.0	6505	1240	1084/01	-150000	100000	000000	0038658	00
16.0	6505	1240	1090/01	-150000	100000	000000	0038672	00
17.0	6505	1240	1096/01	-150000	100000	000000	0038686	00
18.0	6505	1240	1102/01	-150000	100000	000000	0038700	00
19.0	6505	1240	1108/01	-150000	100000	000000	0038714	00
20.0	6505	1240	1114/01	-150000	100000	000000	0038728	00
21.0	6505	1240	1120/01	-150000	100000	000000	0038742	00
22.0	6505	1240	1126/01	-150000	100000	000000	0038756	00
23.0	6505	1240	1132/01	-150000	100000	000000	0038770	00
24.0	6505	1240	1138/01	-150000	100000	000000	0038784	00
25.0	6505	1240	1144/01	-150000	100000	000000	0038798	00

SECTION III

DISCRM

COMPUTER PROGRAM DOCUMENTATION

## T A B L E O F C O N T E N T S

<u>SECTION</u>	<u>TITLE</u>	<u>PAGE</u>
1	SCOPE	49
2	APPLICABLE DOCUMENTS	50
3	REQUIREMENTS	51
	3.1 CP Characteristics	51
	3.1.1 CP Flow Chart	
	3.1.2 CP Timing and Sequencing	
	3.1.3 Storage Allocation	
	3.1.4 Data Base Characteristics	
	3.2 DISCRM Subroutine Characteristics	51
	3.2.1 Executive Routine	53
	3.2.1.1 Description of Executive Routine	
	3.2.1.2 Flow Chart	
	3.2.1.3 Interfaces	
	3.2.1.4 Listing	
	3.3.1 Computer Program Subroutine OUTPUT	62
	3.3.1.1 Description of Subroutine OUTPUT	
	3.3.1.2 Subroutine OUTPUT Flow Chart	
	3.3.1.3 Interfaces	
	3.3.1.4 Listing	
4	TEST DESCRIPTION	77
	4.1 Input Data	77
	4.2 Output Data	85

## S E C T I O N 1

### S C O P E

This specification establishes the requirements for complete identification and acceptance of the computer program to be formally accepted by the procuring agency. EDP program DISCRM was originally written by the Convair Aerospace Division of General Dynamics for use with an IBM 360 computer system under Contract F30602-69-C-0164; however, the necessary changes have been incorporated to make the program compatible with the GE 634/645 computer system at RADC. This documentation has been prepared in accordance with RADC Computer Program Detail Specification, 28 January 1968.

S E C T I O N 2

A P P L I C A B L E D O C U M E N T S

The documents of exact issue shown, form a part of this specification to the extent specified herein. In the event of conflict between documents referenced here and the contents of Sections 3, 4 and 5, the detailed contents of Sections 3 through 5 shall be considered as superceding requirements.

GE-600 Line FORTRAN IV	CPB-1006G
GE-600 Line FORTRAN IV	
Subroutine Libraries	CPB-1620
GE-600 Line General Loader	CPB-1008F
GE-600 Line System Editor	CPB-1138C

## SECTION 3

### REQUIREMENTS

Computer program DISCRM was developed for the purpose of extracting discriminant data from Equivalence Class data made available from computer program SPECT. The Equivalence Class Method of compactly and efficiently storing radar signature data is described in "Radar Signature Investigation Vol. II - Target Classification", RADDC-TR-70-257.

#### 3.1 CP CHARACTERISTICS

Computer program DISCRM extracts three primary discriminants from the Equivalence Class data. These include (1) Equivalence Class Category, i.e., number of significant peaks in a signature, (2) maximum target radar cross section in the signature and (3) maximum separation between significant peaks in the signature. These discriminants represent a measure of target complexity, target size and target length respectively. Computer program DISCRM, which consists of an executive routine and subroutine OUTPUT, is described in detail in the following paragraphs.

##### 3.1.1 CP Flow Chart

Figure 1 depicts the overall flow of the CP.

##### 3.1.2 CP Timing and Sequencing

Run time for the sample problem was approximately 0.78 minutes.

##### 3.1.3 Storage Allocation

26K words of memory were required to load DISCRM.

##### 3.1.4 Data Base Characteristics

Card input data containing equivalence class information is card output of computer program SPECT.

#### 3.2 DISCRM SUBROUTINE CHARACTERISTICS

This paragraph contains the technical description of the computer program subroutines identified in paragraph

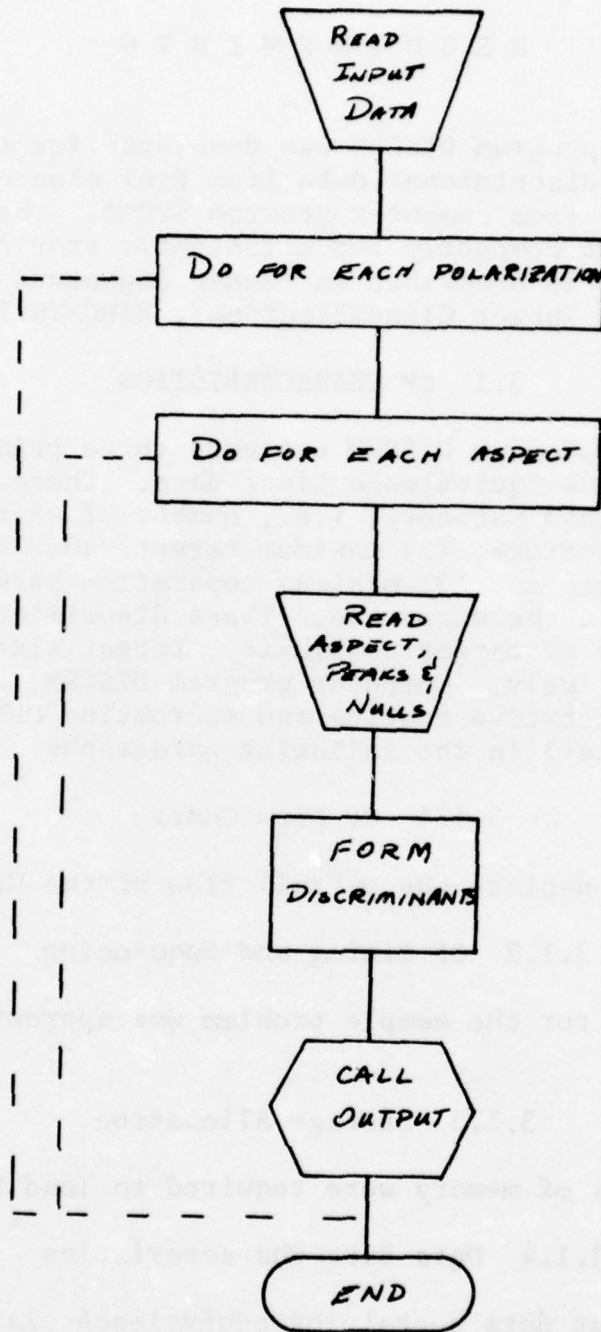

FIGURE 1 OVERALL VIEW OF DISCRM

3.1 of this specification. The instruction listings contained herein by inclusion or reference specify the exact configuration of DISCRM. DISCRM is written in FORTRAN IV language for use with the GE 635/645 computer system.

### 3.2.1 Executive Routine

The executive routine of DISCRM is responsible for (1) reading and testing card input data, (2) forming the discriminant data and (3) transferring output data to subroutine OUTPUT.

#### 3.2.1.1 Description of Executive Routine

The user of DISCRM has the ability, through card input data, to (1) select the target region from which discriminants are formed and (2) to select the dynamic range of the discriminants. The value obtained by subtracting the variable DBDOWN (expressed in dB) from the maximum peak in a radar signature expresses the lower bound below which peaks are not to be considered. The variables RLOW and RHIGH express the minimum and maximum range respectively that is to be considered in obtaining the discriminants from a signature. RLOW and RHIGH are expressed in inches relative to the position of the 0dB radar cross section reference. These variables are illustrated in Figure 2.

The discriminants extracted from the target signature data are (1) EQCL; the number of significant peaks in a signature, (2) SIGMAX; the maximum target radar cross section in the signature and (3) DLRMAX; the maximum separation between peaks in the signature. The procedure by which these discriminants are formed is shown in Figure 2. These discriminants are formed for every polarization of interest.

#### 3.2.1.2 Flow Chart

A flow chart of the executive routine is found in the following pages.

#### 3.2.1.3 Interfaces

3.2.1.3.1 Input Data. Input data is entered via punched cards described in the following paragraphs.

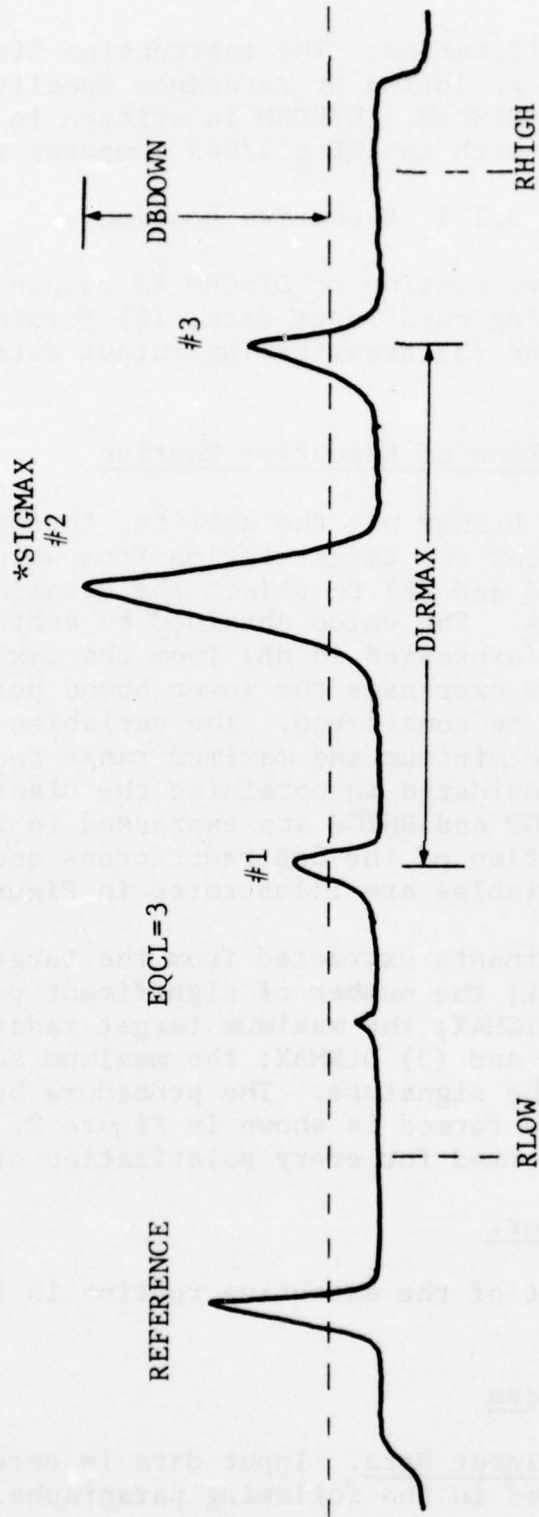
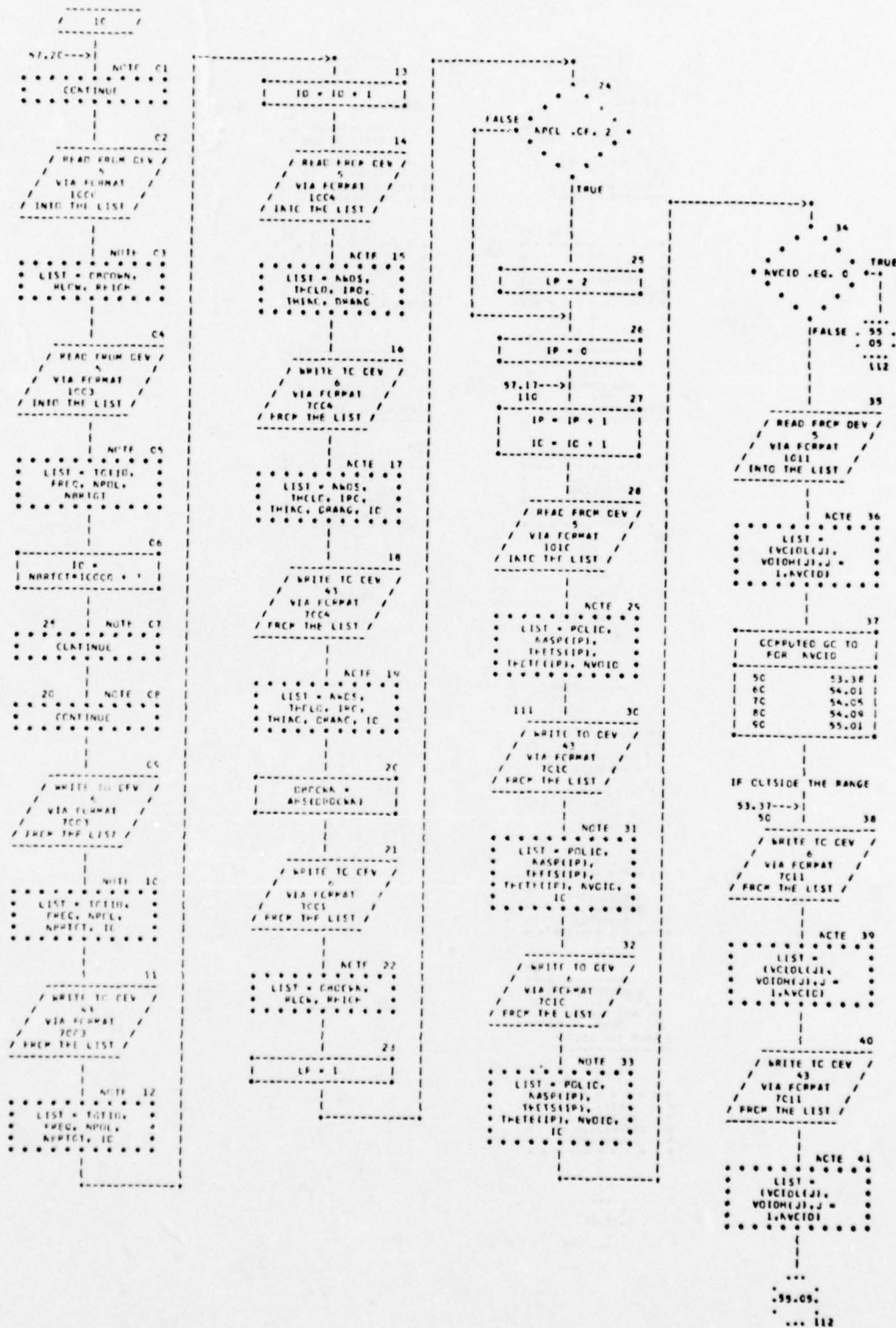
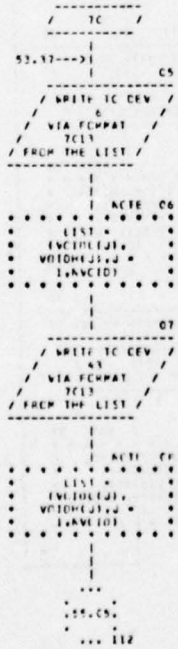
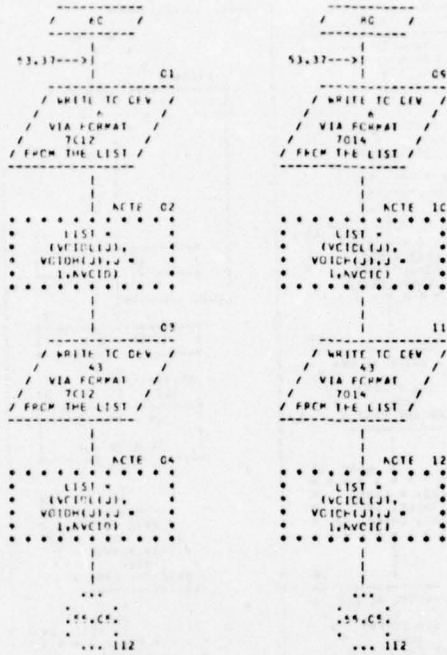

FIGURE 2 DISCRIMINANT FORMATION

AUTOFLOW CHART SET - FWC/SCL DISCRP



AUTOFLOW CHART SET - FWC/SCL DISCRN





AUTOFLOW CHART SET - FNC/SCL DESCRM

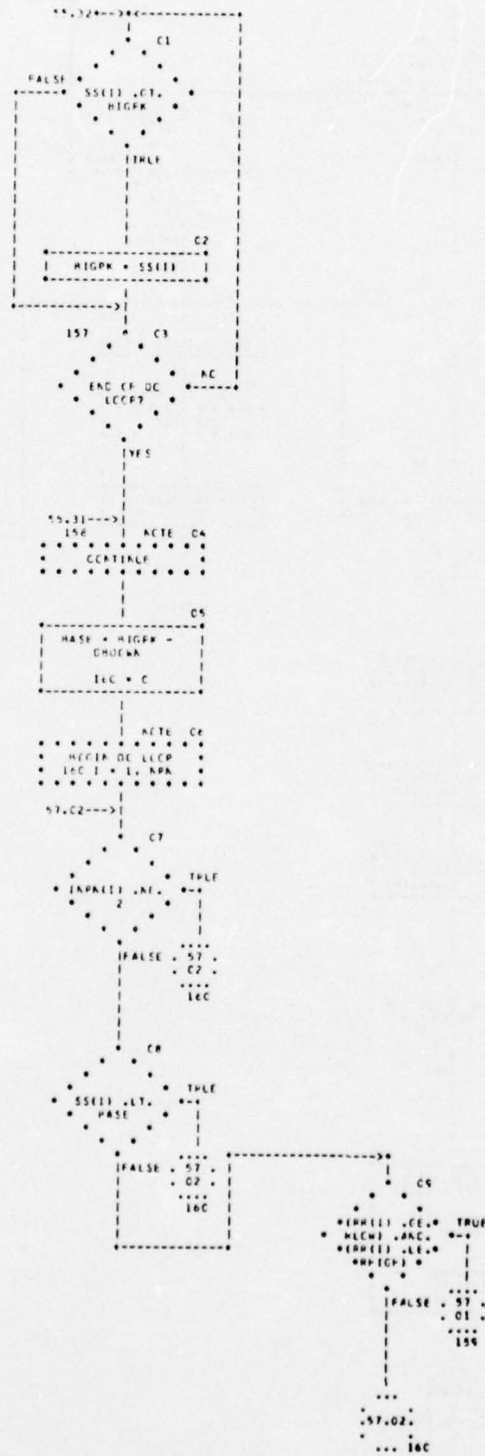

AUTOFLOW CHART SET - FNC/SCL DESCRM

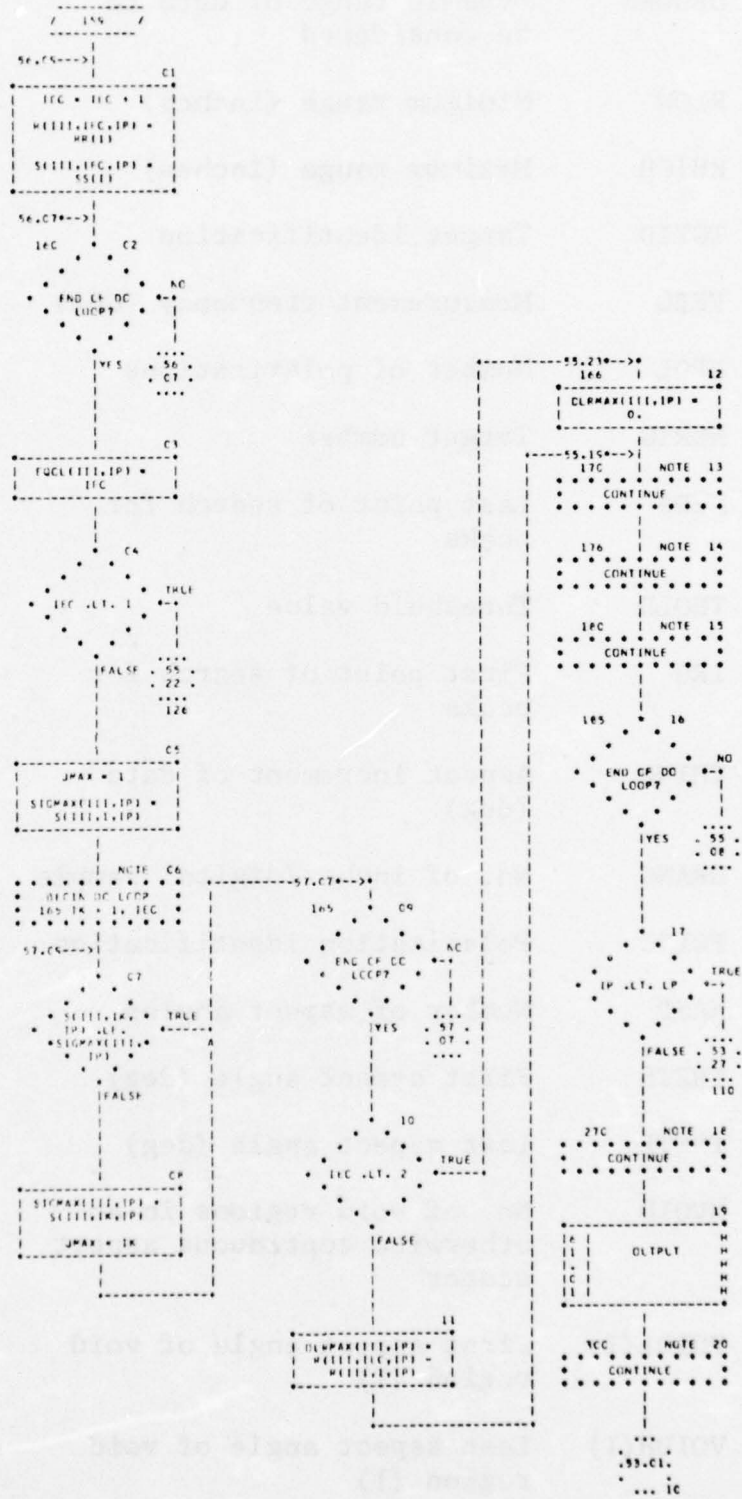

<u>CARD 1</u>	<u>VARIABLE</u>	<u>DEFINITION</u>	<u>COLUMNS</u>
	DBDOWN	Dynamic range of data to be considered	1-10
	RLOW	Minimum range (inches)	11-20
	RHIGH	Maximum range (inches)	21-30
<u>CARD 2</u>	TGTID	Target identification	1-48
	FREQ	Measurement frequency (GHz)	49-55
	NPOL	Number of polarizations	56-60
	NBRTG	Target number	61-66
<u>CARD 3</u>	NWDS	Last point of search for peaks	1-6
	THOLD	Threshold value	7-16
	IRO	First point of search for peaks	17-26
	THINC	Aspect increment of data (deg)	27-36
	DRANG	No. of inches/digital sample	37-46
<u>CARD 4</u>	POLID	Polarization identification	1-12
	NASP	Number of aspect angles	13-18
	THETS	First aspect angle (deg)	19-25
	THETE	Last aspect angle (deg)	26-32
	NVOID	No. of void regions in an otherwise continuous aspect sector	33-36
<u>*CARD 5</u>	VOIDL(I)	First aspect angle of void region (I)	1-5, 11-15...
	VOIDH(I)	Last aspect angle of void region (I)	6-10, 16-20...
	I = 1, NVOID		

\*\*CARD 6

		<u>COLUMNS</u>
THETA	Aspect angle	1-10
ICK	Void region indicator	
	=0; in void region	
	=1; not in void region	11-20
NPN	Number of peaks and nulls	21-30
EC	Number of peaks	31-40
IJPOL	Polarization number	41-50

\*\*CARD 7<sup>+</sup>

INPN(I)	Peak/null indicator	
	=1; Null	
	=2; Peak	2,15...
RR(I)	Location of peak/null (inches)	3-8, 16-21...
SS(I)	Magnitude of peak/null (dBsm)	9-13, 22-26...

I=1, NPN

.  
.  
.

\* Card 5 is not needed if NVOID = 0

+ May require more than one card if NPN > 5.

\*\* Cards 6 and 7<sup>+</sup> are repeated for each aspect angle.  
Cards 2 through N are punched card output of computer  
program SPECT.

3.2.1.3.2 Output Data. Discriminant data is transferred to subroutine OUTPUT for output.

3.2.1.3.3 Subroutine Called. Subroutine OUTPUT is called by the executive routine.

#### 3.2.1.4 Listing

A listing of the executive routine is found in the following pages.

### 3.3.1 Computer Program Subroutine OUTPUT

Subroutine OUTPUT has the function of printing and punching onto cards the discriminant data. Subroutine OUTPUT is written in FORTRAN IV language for use with the GE 635/645 computer system at RADC.

#### 3.3.1.1 Description of Subroutine OUTPUT

In subroutine OUTPUT, the discriminants EQCL, SIGMAX and DLRMAX are printed and punched onto cards for each aspect angle and polarization of interest.

#### 3.3.1.2 Subroutine OUTPUT Flow Chart

A flow chart of subroutine OUTPUT is contained in the following pages.

#### 3.3.1.3 Interfaces

3.3.1.3.1 Input. Input to subroutine OUTPUT consists of the variables in common blocks 1 and 4.

3.3.1.3.2 Output. The output data is described below.

CASE 1: No. of polarizations = 1

<u>CARD 1</u>	<u>VARIABLE</u>	<u>COLUMNS</u>
.	THETA	1-6
.	EQCL	11-15
.	DLRMAX	16-20
.	SIGMAX	21-25
.		
CARD N		

```

C          DISCRM          PROGRAM          1
C***** EXTRACT DISCRIMINANTS FROM SIGNATURE DATA
COMMON/BLOCK1/ THETA(4 ,2),  EQCL(400,2),  DLRMAX(400,2),
1          SIGMAX(4 ,2)
COMMON/BLOCK2/  R(400,1 ,2) ,  S(400,10,2)
COMMON/BLOCK3/  INPN(3 ) ,  RR(30),  SS(30),  NPN
COMMON/BLOCK4/NPOL,NASP(3),ID
COMMON/BLOCK7/ TGTID(48) ,POLID(3)

C          DIMENSION
1          THPTS(3) ,  THETE(3)
3, VOIDL(3) , VOIDH(3)

C
C
C
C
10 CONTINUE
   READ (5,1000)  DBDOWN, RLOW, RHIGH
1000 FORMAT(6F1. )

C
   READ (5,1003) TGTID,FREQ,NPOL,NBRTGT
1003 FORMAT( 48A1,F7.2,I5,I6 )
   ID = NBRTGT*1000 + 3
25 CONTINUE
20 CONTINUE
   WRITE (6,7 03) TGTID,FREQ,NPOL,NBRTGT,ID
   WRITE(43,7 03) TGTID,FREQ,NPOL,NBRTGT,ID
7003 FORMAT( 48A1,F7.2,I5,I6, 7H          F ,I6)
   ID = ID + 1
   READ (5,1004) NWDS,THOLD,IRC,THING,DRANG
1004 FORMAT( I6,F1. ,I10,2F1. )
   WRITE (6,7 04) NWDS,THOLD,IRC,THING,DRANG,ID
   WRITE(43,7 04) NWDS,THOLD,IRC,THING,DRANG,ID
7004 FORMAT( I6,F1. ,I10,F10.1,F10.2,20X, 7H          F ,I6)

C
   DBDOWN = ABS(DBDOWN)
   WRITE (6,7 01) DBDOWN, RLOW, RHIGH
7001 FORMAT( 3 F CONSIDER ONLY PEAKS LESS THAN,F5.1,2 H DB DOWN AND BET
   WWEEN,F7.1, 7H AND ,F7.1, 8H INCHES )

C
C
C
C
   LP = 1
   IF( NPOL .GE. 2 ) LP = 2

C
C
   IP =
110 IP = IP +
   ID = ID + 1
   READ (5,1010) POLID,NASP(IP),THPTS(IP),THETE(IP),NVOID

```

```

1010 FORMAT( 3A4,I6,2F7.0,I4 )
111 WRITE(43,7 11) POLID,NASP(IP),THETS(IP),THETE(IP),NVOID,ID
WRITE (6,7 11) POLID,NASP(IP),THETS(IP),THETE(IP),NVOID,ID
7010 FORMAT( 3A4,I6,2F7.1,I4,30X,7H P , I6 )
IF( NVOID .EQ. ) GO TO 112
READ (5,1 11) ( VOIDL(J),VOIDH(J),J=1,NVOID )
1011 FORMAT ( 1 F6. )
GO TO (5,60,7 ,8 ,90);NVOID
50 WRITE (6,7 11) (VOIDL(J), VOIDH(J),J=1,NVOID)
WRITE(43,7 11) (VOIDL(J), VOIDH(J),J=1,NVOID)
7011 FORMAT ( 2F6.1, 54X,7H P,I6)
GO TO 112
60 WRITE (6,7 12) (VOIDL(J), VOIDH(J),J=1,NVOID)
WRITE(43,7 12) (VOIDL(J), VOIDH(J),J=1,NVOID)
7012 FORMAT ( 4F6.1, 42X,7H P,I6)
GO TO 112
70 WRITE (6,7 13) (VOIDL(J), VOIDH(J),J=1,NVOID )
WRITE(43,7 13) (VOIDL(J), VOIDH(J),J=1,NVOID)
7013 FORMAT ( 6F6.1, 3 X,7H P,I6)
GO TO 112
80 WRITE (6,7 14) (VOIDL(J), VOIDH(J),J=1,NVOID)
WRITE(43,7 14) (VOIDL(J), VOIDH(J),J=1,NVOID)
7014 FORMAT ( 8F6.1, 18X,7H P,I6)
GO TO 112
90 WRITE (6,7 15) (VOIDL(J), VOIDH(J),J=1,NVOID)
WRITE(43,7 15) (VOIDL(J), VOIDH(J),J=1,NVOID)
7015 FORMAT ( 11F6.1, 6X,7H P,I6)
112 CONTINUE

```

C NPTS = NASP(IP)

C DO 185 III=1,NPTS  
READ (5,1 2) THETA(III,IP),ICK,NPN,EC  
1,IJPOL  
1020 FORMAT( F1 . ,9X,I1,I1 ,F1 .0,I10 )  
WRITE (6,1 21) THETA(III,IP),ICK,NPN,EC,IJPOL  
1021 FORMAT( F1 . ,2I1 ,F1 .1,I10 )

C IF( ICK .GT. 0 ) GO TO 120  
IF( III .EQ. 1 ) GO TO 125  
IF( EQCL(III,IP) .EQ. ) GO TO 125  
DO 115 LLL=1,IEC  
R(III,LLL,IP) = R(III-1,LLL,IP)  
115 S(III,LLL,IP) = S(III-1,LLL,IP)  
EQCL(III,IP) = EQCL(III-1,IP)  
SIGMAX(III,IP) = SIGMAX(III-1,IP)  
DLRMAX(III,IP) = DLRMAX(III-1,IP)  
GO TO 17.

C 120 IF(NPN .GT. 0 ) GO TO 130  
125 EQCL(III,IP) = 0.  
126 CONTINUE

```

        SIGMAX(III,IP) = THOLD
        GO TO 166
C
130 READ (5,1030)(INPN(I),RR(I),SS(I),I=1,NPN)
1630 FORMAT( ('X,5(I1,F6.1,FS.1X)') )
        WRITE (6,1031)(INPN(I),RR(I),SS(I),I=1,NPN)
1031 FORMAT( ('X,5(I1,F6.1,FS.1X)') )
C
129 IF( EC .LT. 1.) GO TO 125
C
155 CONTINUE
        BIGPK = SS(1)
        IF ( NPN .EQ. 1 ) GO TO 158
        DO 157 I = 2,NPN
        IF (SS(I) .GT. BIGPK ) BIGPK = SS(I)
157 CONTINUE
158 CONTINUE
        BASE = BIGPK - D3DOWN
        IEC =
        DO 160 I=1,NPN
        IF( INPN(I) .NE. 2 ) GO TO 160
        IF( SS(I) .LT. BASE ) GO TO 160
        IF ((RR(I) .GE. RLOW) .AND. (RR(I) .LE. RHIGH )) GO TO 159
        GO TO 160
159 IEC = IEC + 1
        R(III,IEC,IP) =RR(I)
        S(III,IEC,IP) =SS(I)
160 CONTINUE
C
        EQCL(III,IP) = IEC
        IF( IEC .IT. ' ) GO TO 126
        JMAX =
        SIGMAX(III,IP) = S(III,1,IP)
        DO 165 IK=1,IEC
        IF( S(III,IK,IP) .LE. SIGMAX(III,IP) ) GO TO 165
        SIGMAX(III,IP) = S(III,IK,IP)
        JMAX = IK
165 CONTINUE
        IF( IEC .LT. 2 ) GO TO 166
        DIRMAX(III,IP) = R(III,IEC,IP) - R(III,1,IP)
        GO TO 17
166 DIRMAX(III,IP) = 0.
C
170 CONTINUE
176 CONTINUE
C
C
180 CONTINUE
185 CONTINUE
C
        IF( IP .LT. LP ) GO TO 110
C

```

```

C 270 CONTINUE
C      CALL      OUTPUT
350 CONTINUE
GO TO 1
END
SUBROUTINE OUTPUT
COMMON/BLOCK1/ THETA(400,2),   EQCL(400,2), DLRMAX(400,2),
1          SIGMAX(400,2)
C
C      COMMON/BLOCK4/NPOL,NASP(3),ID
C
C      NPTS = NASP(1)
C
C
C      WRITE (6,2000)
2000 FORMAT (///50H THETA   ECV   DLRMXV SIGMXV       ECH   DLRMXH SIGMXH )
C
C      GO TO (10,20,20),NPOL
C
C      10 DO 12 I=1,NPTS
C          ID = ID + 1
C          WRITE(6,2010) THETA(I,1),EQCL(I,1),DLRMAX(I,1),SIGMAX(I,1),ID
2010 FORMAT( F6.1,F5.1,1X,2(1X,F6.1),40X,       7H           P .I6)
C          WRITE(43,1010) THETA(I,1),EQCL(I,1),DLRMAX(I,1),SIGMAX(I,1),ID
1010 FORMAT( F6.1,4X,3F5.1, 41X,           7H           P .I6)
C
C      12 CONTINUE
C          RETURN
C
C
C      20 CONTINUE
C          DO 3 I=1,NPTS
C              ID = ID + 1
C              WRITE(6,2020) THETA(I,1),EQCL(I,1),DLRMAX(I,1),SIGMAX(I,1),
1              EQCL(I,2),DLRMAX(I,2),SIGMAX(I,2),ID
2020 FORMAT( F6.1,F5.1,1X,2(1X,F6.1),2X,F5.1,1X,2(1X,F6.1),18X,7H
1              ,I6)
C              WRITE(43,1010) THETA(I,1),EQCL(I,1),DLRMAX(I,1),SIGMAX(I,1),
1              EQCL(I,2),DLRMAX(I,2),SIGMAX(I,2),ID
1010 FORMAT( F6.1,4X,6F5.1, 26X,           7H           P .I6)
C
C      30 CONTINUE
C
C      RETURN
C      END

```

```

#28.0      134.5      165.0
MODEL 6/14 TWO SPHERES, ONE JACK      9.00      1      1
450      -52.0      200      1.0      0.51
VERT/VERT      91      0.0      90.0
0.0      7      3.0      1

```

1	122.6-52.8	2	135.9-21.8	1	140.6-40.4	2	148.3-26.1	1	154.9-51.8
2	162.6-28.6	1	164.7-46.7	2	168.3-42.2	1	171.3-53.2		
	1.0			7	3.0		1		
1	123.1-52.8	2	136.5-21.6	2	140.0-40.6	2	148.3-25.0	1	154.4-51.8
2	163.1-29.4	1	164.2-46.8	2	167.8-42.1	1	170.8-53.6		
	2.0			7	3.0		1		
1	124.1-52.7	2	136.5-21.5	1	140.6-41.5	2	148.8-27.1	1	154.9-52.1
2	162.6-31.0	1	165.2-46.3	2	167.8-43.1	1	171.3-54.9		
	3.0			7	3.0		1		
1	123.6-53.1	2	136.5-21.8	1	140.6-42.4	2	148.8-27.4	1	154.9-52.3
2	161.1-35.6	1	164.7-46.5	2	167.8-43.9	1	170.8-53.5		
	4.0			11	5.0		1		
1	122.6-54.0	2	126.2-49.5	1	127.7-49.6	2	137.0-22.6	1	140.6-42.6
2	149.3-29.3	1	150.9-52.7	2	161.1-38.8	1	166.2-47.4	2	168.3-46.1
1	170.8-53.6								
	5.0			8	3.0		1		
1	124.1-52.9	2	135.9-22.0	1	141.1-43.5	2	147.7-30.3	1	154.4-53.3
1	157.0-53.3	2	161.6-45.7	1	170.3-53.9				
	6.0			8	3.0		1		
1	123.6-53.7	2	136.5-21.8	2	141.1-44.4	2	148.3-31.3	1	154.4-53.9
1	162.6-53.0	2	167.2-49.6	1	169.8-53.8				
	7.0			11	4.0		1		
1	125.2-54.0	2	136.5-21.9	2	141.6-45.4	2	148.3-32.5	1	154.4-53.4
1	155.0-53.9	2	159.5-45.9	1	162.1-53.4	1	166.2-53.5	2	171.3-55.2
1	173.4-53.8								
	8.0			7	3.0		1		
1	125.2-52.7	2	136.5-22.4	1	142.1-47.9	2	148.8-34.3	1	154.9-51.6
2	159.5-41.6	1	169.3-52.9						
	9.0			9	4.0		1		
1	125.2-52.8	2	136.5-22.1	2	142.6-50.8	2	148.3-35.5	1	154.9-50.3
2	160.1-38.6	1	162.6-47.5	2	164.2-46.2	1	169.3-53.1		
	10.0			7	3.0		1		
1	126.2-53.0	2	136.5-22.2	1	142.1-45.6	2	146.2-35.0	1	154.4-48.7
2	159.5-36.2	1	168.8-53.0						
	11.0			9	4.0		1		
1	125.7-54.4	2	136.5-21.6	1	141.1-43.8	2	148.3-32.7	1	153.9-48.4
2	160.1-35.4	1	163.1-48.8	2	164.7-48.0	1	169.8-53.9		
	12.0			7	3.0		1		
1	127.2-53.2	2	136.5-21.9	1	140.6-42.7	2	148.3-32.6	1	154.4-48.4
2	161.6-33.5	1	169.3-52.9						
	13.0			7	3.0		1		
1	127.2-53.0	2	136.5-21.9	1	140.6-41.6	2	148.3-30.0	1	152.9-49.1
2	161.1-32.3	1	168.3-54.7						
	14.0			8	3.0		1		
1	126.2-53.1	2	136.5-21.7	1	140.6-41.8	2	147.7-29.0	1	153.9-50.8
2	160.6-31.3	1	166.2-53.4	1	171.3-53.6				
	15.0			8	3.0		1		
1	127.2-52.2	2	136.5-21.5	1	140.6-42.5	2	147.7-26.0	1	153.4-52.3
1	153.9-52.5	2	161.1-29.1	1	166.7-53.3				
	16.0			8	3.0		1		
1	126.7-52.9	2	137.0-21.8	1	140.6-45.5	2	148.8-25.9	1	152.9-52.8
1	153.9-53.5	2	162.1-27.5	1	166.2-53.8				

1	127.7-52.3	2	136.5-21.9	7	141.1-45.7	2	148.3-24.4	1	153.9-51.9
2	161.1-26.7	1	166.7-53.1						
1	126.2-53.0	2	137.1-21.9	8	141.0-43.6	2	148.8-22.9	1	153.4-50.5
2	161.1-25.8	1	166.2-53.2						
1	121.1-53.6	1	125.7-53.1	11	136.5-20.8	1	140.6-42.8	2	147.7-21.4
1	153.4-48.2	2	160.6-24.7						
1	175.4-54.7								
1	125.2-53.7	2	137.1-21.6	9	141.0-40.4	2	148.3-21.1	1	152.9-44.8
2	161.6-24.4	1	170.3-53.8						
1	117.5-53.3	2	136.5-21.7	8	141.0-38.5	2	147.2-20.9	1	152.4-43.7
2	160.6-24.6	1	178.1-54.0						
1	117.5-53.3	2	136.5-21.4	8	141.6-34.6	2	147.2-20.3	1	152.4-44.4
2	160.1-24.2	1	167.8-51.4						
1	112.9-53.1	2	114.4-51.7	15	117.0-52.8	1	117.5-53.0	2	120.0-50.8
1	127.2-51.7	2	137.1-21.2						
2	160.6-23.3	1	167.8-53.0						
1	115.9-53.3	2	136.5-21.8	13	142.1-36.1	2	147.7-20.1	1	152.4-46.6
2	160.6-22.5	1	169.3-52.8						
1	180.1-54.1	2	182.6-50.9						
1	113.4-53.7	2	121.1-51.6	15	123.1-52.3	2	124.7-50.9	1	127.2-51.9
2	137.5-21.5	1	141.6-35.4						
1	171.9-53.1	1	173.4-53.1						
1	111.8-52.8	2	137.5-21.3	12	141.0-41.5	2	147.7-19.2	1	152.9-47.5
2	160.6-21.6								
1	192.4-52.9	1	194.4-53.1						
1	112.3-52.8	1	119.1-52.7	19	119.5-53.0	2	122.1-50.4	2	137.5-21.1
1	139.5-41.4	2	147.7-18.6						
1	174.4-54.4	1	176.5-52.9						
2	183.7-51.1	1	187.2-52.6						
1	117.5-53.1	2	123.6-50.9	14	126.2-51.9	2	138.0-20.8	1	141.6-33.1
2	148.3-18.4	1	151.8-41.4						
1	182.1-53.1	1	182.6-53.0						
1	114.4-52.9	2	121.1-50.6	14	123.1-51.7	2	137.5-21.2	1	142.1-33.6
2	147.7-19.8	1	152.4-41.1						
1	173.4-53.1	1	181.6-53.0						
1	111.8-53.6	1	115.4-53.5	14	121.6-51.2	1	123.6-52.8	2	126.2-51.4
1	127.7-52.3	2	137.5-21.5						
2	160.1-24.8	1	168.8-53.9						

1	117.0-53.5	2	126.6-51.5	11	122.6-52.2	2	137.5-21.0	1	142.1-34.3
2	147.7-21.8	1	151.8-44.3	2	167.1-24.7	1	166.2-53.6	1	168.8-53.1
1	172.9-53.0								
	32.0			11	4.0		1		
1	123.6-53.3	2	126.2-51.7	1	128.2-52.1	2	137.0-21.2	1	140.6-40.8
2	147.2-22.3	1	152.4-47.5	2	159.0-24.6	1	164.7-52.9	1	170.3-53.6
1	184.7-53.6								
	33.0			13	5.0		1		
1	119.0-53.8	2	126.6-52.4	1	123.1-53.2	1	125.7-53.1	2	137.5-21.1
1	140.6-41.9	2	147.7-22.5	1	151.8-45.7	2	159.5-25.7	1	166.7-52.9
1	169.3-52.8	2	176.7-54.7	1	178.0-53.5				
	34.0			6	3.0		1		
1	126.2-52.9	2	138.7-21.4	1	148.3-21.9	1	151.8-41.5	2	159.5-26.2
1	166.7-53.3								
	35.0			10	5.0		1		
1	119.5-53.1	2	126.2-50.6	1	127.7-51.1	2	138.0-20.9	1	141.6-32.8
2	147.7-22.1	1	152.4-40.8	2	159.0-26.0	2	170.3-49.0	1	173.4-53.6
	36.0			12	5.0		1		
1	117.5-53.1	2	124.7-51.0	1	126.7-51.7	2	138.0-20.6	1	142.1-32.8
2	147.7-21.2	1	151.8-43.7	2	159.0-25.7	1	165.7-53.3	1	168.3-54.6
2	170.3-49.8	1	172.4-53.1						
	37.0			13	6.0		1		
2	121.1-51.7	1	123.1-52.6	2	125.2-51.2	1	127.7-52.5	2	138.5-20.8
1	142.1-32.8	2	148.3-20.5	1	151.8-45.4	2	160.1-25.2	1	166.2-53.0
2	167.8-50.4	1	169.8-54.1	1	175.4-53.0				
	38.0			17	6.0		1		
1	115.9-52.9	1	122.1-52.7	2	136.5-20.8	1	142.1-36.5	2	147.7-20.3
1	151.8-45.3	2	159.7-24.0	2	163.6-49.9	2	165.2-48.3	1	169.3-31.5
1	173.9-53.7	1	181.6-53.3	2	183.7-51.6	1	186.2-52.9	1	187.2-53.1
2	189.8-50.1	1	192.9-53.1						
	39.0			11	4.0		1		
1	114.4-53.1	1	121.6-53.0	2	125.2-50.5	2	139.0-20.8	2	148.8-19.3
1	150.8-38.6	2	159.5-22.5	1	168.3-51.3	1	171.9-53.4	1	177.0-53.1
1	182.6-51.9								
	40.0			12	5.0		1		
1	109.3-52.9	2	125.7-50.4	1	128.8-51.3	2	139.0-20.4	1	142.6-31.9
2	148.3-19.2	1	151.3-37.4	2	159.0-22.6	1	167.8-51.2	2	170.3-47.5
1	172.9-53.4	1	179.7-53.5						
	41.0			15	6.0		1		
1	112.3-53.1	2	124.7-50.3	1	129.3-50.2	2	139.0-20.3	1	142.6-31.3
2	147.7-19.2	1	151.8-40.6	2	158.5-23.4	1	166.2-53.0	1	168.3-54.1
2	169.8-49.9	1	171.9-52.7	2	173.9-49.0	1	177.0-52.9	1	182.1-53.0
	42.0			11	6.0		1		
2	139.5-21.1	2	148.3-20.8	2	157.8-42.4	2	159.0-23.3	1	162.6-51.1
2	164.2-48.2	1	166.2-51.5	2	167.8-49.2	1	170.3-53.0	1	181.6-53.7
2	194.4-49.7								
	43.0			12	5.0		1		
1	121.6-51.8	2	139.5-20.7	2	148.3-20.8	1	151.3-40.6	2	158.5-23.4
1	162.1-47.3	2	164.7-46.7	1	173.9-52.7	2	176.0-50.5	1	178.5-53.1
1	182.6-52.8	1	188.8-52.6						
	44.0			10	4.0		1		

1	113.9-54.4	1	123.6-52.7	2	125.2-50.8	1	127.7-52.5	2	138.5-21.0
1	142.6-32.5	2	147.2-21.2	1	152.9-34.3	2	158.0-23.4	1	168.3-51.8
	45.0			10	4.0		1		
1	109.8-53.5	1	129.3-52.4	2	139.5-20.5	1	143.6-29.1	2	147.7-20.5
1	152.9-36.8	2	158.0-24.7	1	166.7-52.0	2	169.3-48.7	1	178.0-54.5
	46.0			13	6.0		1		
2	139.0-20.8	1	143.6-31.4	2	147.2-20.6	1	150.3-42.4	2	157.5-24.7
1	161.6-50.9	2	163.1-47.1	1	165.2-52.8	1	182.6-53.5	2	184.7-51.6
1	186.7-52.7	1	191.9-52.7	2	194.4-50.7				
	47.0			17	7.0		1		
1	115.4-53.9	2	117.7-51.8	1	119.5-53.3	2	121.1-51.9	1	123.6-53.5
2	139.5-20.9	2	147.7-20.3	1	151.8-42.6	2	157.5-24.4	1	161.6-50.9
2	163.6-46.7	1	167.2-52.5	1	173.4-53.1	1	184.2-53.0	1	187.8-53.2
2	190.3-51.0	1	193.4-53.3						
	48.0			12	6.0		1		
1	116.5-53.9	2	121.1-51.8	1	122.6-52.5	2	125.2-51.7	2	140.0-21.6
1	143.6-31.9	2	148.3-19.9	1	151.8-33.1	2	157.5-24.1	1	162.1-51.2
2	163.6-48.0	1	167.2-52.9						
	49.0			12	6.0		1		
1	112.3-53.3	2	118.4-51.3	2	127.2-50.1	1	128.8-51.3	2	140.0-20.7
1	143.1-27.7	2	147.7-18.4	1	152.9-33.5	2	157.5-23.5	1	164.2-52.8
2	168.3-49.2	1	176.5-53.2						
	50.0			17	7.0		1		
2	118.5-51.1	1	121.1-52.7	2	122.6-50.9	1	125.2-51.8	2	139.0-20.4
1	143.1-28.9	2	147.2-19.1	1	150.3-40.1	2	156.5-23.2	1	161.1-50.0
2	163.1-45.7	1	165.7-53.0	2	169.3-53.9	1	175.4-53.7	1	186.7-53.7
1	189.3-53.2	2	193.9-50.0						
	51.0			17	7.0		1		
1	115.4-53.3	2	118.0-52.2	1	119.5-53.1	2	140.0-20.9	2	147.2-20.3
1	151.8-36.7	2	157.7-23.1	1	161.1-51.3	2	163.1-48.1	1	166.7-51.6
1	173.4-53.7	2	175.4-51.5	1	178.0-53.5	1	181.6-53.2	1	186.8-53.5
2	190.3-51.8	1	194.9-53.3						
	52.0			11	5.0		1		
1	116.5-52.9	2	124.7-50.7	2	141.6-21.4	1	143.6-30.5	2	148.3-20.4
1	152.4-31.8	2	157.7-23.3	1	166.7-50.2	2	168.3-49.1	1	170.3-52.5
1	178.5-53.1								
	53.0			10	3.0		1		
1	115.9-52.4	1	119.5-51.7	2	129.8-51.7	2	140.0-20.9	1	143.6-27.0
2	147.2-20.3	1	152.9-32.6	2	156.5-23.7	1	162.6-52.8	1	178.0-53.9
	54.0			17	7.0		1		
1	115.4-53.2	2	124.7-50.8	1	129.3-51.9	2	141.1-21.0	1	144.2-28.1
2	147.2-21.1	1	149.8-43.5	2	156.5-24.3	2	162.6-47.1	1	165.2-53.0
1	168.8-53.3	1	176.7-53.9	1	182.6-53.5	2	186.2-53.5	1	188.3-53.6
1	188.8-53.5	2	193.4-49.5						
	55.0			11	6.0		1		
2	121.1-51.5	1	123.6-52.5	2	141.0-20.6	2	147.2-20.4	1	149.3-40.1
2	156.0-24.3	2	167.8-50.2	1	169.8-53.4	1	179.5-53.2	2	182.6-53.3
1	184.7-53.7								
	56.0			12	5.0		1		
1	118.0-53.2	2	121.1-51.5	2	123.6-52.3	2	127.2-51.2	1	129.8-52.3
2	141.1-21.1	1	144.2-27.9	2	148.3-19.9	1	152.4-30.5	2	156.5-23.8
1	170.3-53.0	1	171.9-52.8						

1	112.3-57.0-53.1	2	116.5-51.3	2	124.1-50.7-50.0	1	126.7-51.2	2	141.1-20.9
1	144.2-24.9	2	147.2-20.1	1	152.4-31.9	2	155.4-25.4	1	164.7-53.0
1	168.8-54.4	2	17.3-50.0	2	172.4-53.4	1	174.4-53.7	2	176.0-50.6
1	179.5-53.7	1	194.4-52.3						
	58.0			16	7.0		1		
1	115.4-52.9	2	119.5-51.4	2	129.8-50.5	1	131.3-51.9	2	141.6-20.6
1	144.7-26.4	2	148.3-19.2	2	156.5-23.6	1	160.1-50.9	2	161.6-46.2
1	166.2-53.2	1	166.7-53.1		181.6-52.9	1	186.2-53.4	1	186.7-53.0
2	191.3-48.2								
	59.0			14	6.0		1		
1	114.4-53.2	2	115.9-52.3	1	116.0-52.8	1	118.5-52.9	2	141.6-21.3
2	147.7-19.9	1	151.3-29.9	2	155.4-23.4	1	159.5-50.6	2	161.1-47.9
1	165.7-52.6	1	176.5-53.0	2	179.0-52.0	1	181.6-53.0		
	60.0			14	6.0		1		
1	112.3-53.4	1	119.5-52.5	2	122.1-50.5	1	127.7-51.1	2	142.1-20.5
1	144.7-24.3	2	148.3-19.1	2	151.8-27.4	2	156.0-22.8	1	162.1-50.9
2	166.2-48.9	1	171.9-52.7	2	173.4-50.6	1	175.4-52.7		
	61.0			17	7.0		1		
1	111.8-54.2	2	124.7-50.8	2	142.1-20.6	1	144.7-23.7	2	147.7-20.5
1	150.8-33.2	2	154.9-23.8		16.1-49.5	2	161.6-47.3	1	164.2-52.5
1	167.8-53.2	1	175.4-53.7	2	177.5-50.9	1	179.5-53.2	1	182.6-53.4
1	187.8-53.2	2	191.9-49.8						
	62.0			9	4.0		1		
1	116.5-52.9	2	120.6-51.0	2	122.1-51.5	2	142.1-21.4	1	145.2-28.8
2	148.3-21.9	2	155.4-24.3	1	166.2-52.6	1	177.5-53.1		
	63.0			12	5.0		1		
1	113.4-53.5	1	117.5-52.8	2	142.6-21.7	1	144.7-27.0	2	147.7-20.1
1	151.3-29.2	2	155.4-23.3	1	159.5-49.2	2	161.1-46.7	1	162.6-50.4
2	164.7-49.4	1	168.8-53.8						
	64.0			19	7.0		1		
1	112.3-53.1	2	115.4-50.6	1	117.0-52.3	2	123.6-50.3	2	142.6-20.0
1	145.2-22.1	2	147.2-19.7	1	151.3-28.3	2	154.4-25.1	1	163.1-53.1
1	163.6-53.4	2	165.7-48.7	1	171.3-53.2	1	173.4-53.1	2	177.0-49.8
1	180.6-52.5	1	182.6-53.4	1	188.8-52.9	1	193.9-53.1		
	65.0			17	5.0		1		
1	119.5-53.7	1	121.1-53.3	1	127.7-52.7	1	131.8-53.6	2	142.6-20.4
1	144.7-23.5	2	147.7-20.2	1	151.8-32.6	2	154.4-25.0	1	165.2-53.4
1	177.0-54.7	2	179.5-50.7	1	182.1-53.1	2	184.7-51.4	1	188.3-53.3
1	189.3-53.6	2	191.9-50.8						
	66.0			10	5.0		1		
1	125.2-53.1	2	128.2-50.8	2	143.1-21.8	1	145.2-31.1	2	148.3-19.8
1	151.3-26.8	2	154.4-22.7	1	158.0-50.9	2	159.5-47.2	1	164.2-53.3
	67.0			11	5.0		1		
1	111.8-53.1	2	148.3-18.4	1	151.8-25.5	2	154.4-22.8	1	156.0-43.5
2	157.5-42.1	1	162.6-51.5	2	164.7-46.6	1	172.4-53.4	2	176.0-51.5
1	178.0-53.1								
	68.0			17	7.0		1		
1	113.9-53.4	1	118.1-52.6	2	129.3-50.5	1	132.4-51.3	2	144.2-19.3
1	151.8-33.2	2	154.9-24.2	1	16.6-50.8	2	162.1-47.1	1	164.2-52.6
1	177.5-52.8	2	179.5-51.0	1	181.6-52.5	2	184.2-50.2	1	187.8-52.5
2	189.8-51.4	1	193.4-51.3						

69.0		11		1	
1	117.5-52.7	2	121.6-50.8	2	142.1-22.3
1	149.8-29.7	2	152.4-23.4	1	161.1-49.2
1	182.1-52.6			2	162.6-48.0
				1	144.7-30.4
				2	147.2-21.4
				1	164.7-52.6
70.0		11		1	
1	113.9-52.9	2	133.8-50.0	2	132.4-50.5
2	147.2-19.4	1	151.8-25.1	2	153.9-22.9
1	172.4-53.1			1	163.1-50.6
				2	144.2-20.4
				2	145.7-21.5
				2	165.7-46.2
71.0		14		1	
1	117.0-53.4	2	120.1-50.9	2	121.6-51.9
1	150.8-25.9	2	152.4-24.0	1	165.7-53.7
2	183.7-49.9	1	188.3-51.5	2	189.8-50.4
				1	192.4-52.4
				2	123.1-51.0
				1	169.3-53.1
				1	177.0-53.5
72.0		13		1	
1	115.4-53.1	2	131.3-50.0	2	143.6-22.8
1	150.3-31.8	2	152.9-24.7	2	161.6-47.9
1	178.5-53.4	2	192.4-55.2	1	194.4-53.4
				2	145.2-25.7
				2	147.7-21.9
				1	165.7-53.1
				1	169.3-52.6
73.0		13		1	
1	113.9-52.9	1	119.5-53.1	2	144.7-21.1
1	150.8-22.1	2	152.9-21.6	1	156.0-47.7
2	164.7-48.5	1	167.8-53.0	1	171.3-53.7
				2	146.2-23.0
				1	148.3-19.1
				1	162.1-52.2
74.0		14		1	
1	113.9-53.9	2	115.9-52.4	2	117.5-52.7
2	145.7-17.1	1	151.3-26.7	2	152.9-25.7
1	165.2-53.3	1	179.1-53.6	2	184.2-50.6
				1	186.2-52.7
				2	122.1-51.1
				1	160.6-52.6
				2	163.6-50.6
75.0		11		1	
1	118.5-52.9	2	146.7-21.5	2	149.8-31.1
2	161.6-46.8	1	166.2-53.7	1	167.2-53.9
1	182.1-53.3			2	152.4-22.2
				1	160.1-51.3
				2	177.5-53.6
				2	180.1-50.9
76.0		7		1	
1	119.5-52.9	2	148.3-20.9	1	150.8-23.7
2	164.2-48.8	1	166.2-53.1	2	152.4-23.1
				1	161.6-50.6
77.0		14		1	
1	114.4-52.7	1	126.2-51.5	2	131.8-49.3
1	160.6-52.5	2	163.1-48.3	1	168.3-52.5
2	182.1-48.3	1	185.7-51.2	2	188.3-49.7
				1	191.9-52.6
				2	133.9-50.5
				1	170.8-52.8
				1	175.4-53.0
78.0		8		1	
1	120.0-53.4	2	146.2-19.9	2	152.4-26.7
1	164.7-53.6	1	167.2-53.2	1	183.1-53.4
				2	159.0-50.9
				2	161.1-49.2
79.0		8		1	
1	113.9-52.9	2	121.6-50.6	2	144.7-26.5
1	159.0-47.7	1	167.8-52.8	1	171.3-52.9
				2	146.2-29.1
				2	148.3-21.7
80.0		15		1	
1	111.8-53.6	2	122.6-49.3	2	129.3-50.8
2	146.7-15.7	1	161.6-50.7	2	162.6-48.7
2	183.7-49.1	1	186.2-52.3	1	188.3-52.1
				1	190.3-53.2
				2	132.4-49.6
				1	172.4-53.3
				1	176.5-53.7
				1	192.9-53.2
81.0		15		1	
1	120.6-53.1	2	123.6-53.8	1	125.7-53.3
2	146.7-18.1	1	149.8-29.5	2	151.8-25.3
1	164.7-53.2	1	166.7-55.4	2	179.5-53.1
				2	131.3-51.2
				1	134.4-52.8
				2	157.5-45.9
				1	184.7-53.8
82.0		9		1	
1	119.5-53.1	2	128.2-51.0	2	131.3-52.6
2	151.3-23.7	1	158.1-51.5	2	162.1-49.2
				1	145.2-30.2
				1	146.7-34.5

1	108.2-52.9	2	127.2-48.9	2	147.2-15.6	1	159.0-49.7	2	161.6-48.0
1	177.5-52.3	2	183.7-47.4	1	189.3-52.8	1	194.4-52.4		
	83.0			9	4.0				
1	120.0-53.1	2	146.7-17.3	1	157.5-46.5	2	159.0-45.8	1	167.8-53.1
1	181.1-53.4			6	2.0				
	84.0								
1	132.9-53.8	1	137.5-52.8	2	157.8-23.6	1	153.4-44.4	2	154.9-43.3
1	158.0-52.4			6	2.0				
	85.0								
1	110.3-53.5	2	123.6-48.9	2	147.2-15.9	1	159.0-48.4	2	161.6-46.7
1	164.7-51.4	2	166.2-49.7	1	168.3-51.2	2	169.8-50.1	1	173.4-53.0
1	178.0-52.7	2	183.1-48.2	1	188.3-52.6				
	86.0			13	6.0				
1	108.2-53.3	1	111.8-53.3	2	114.4-51.8	1	117.5-52.9	2	122.6-49.7
1	126.2-51.4	2	128.8-50.1	2	134.9-49.6	1	136.5-50.5	2	147.7-17.7
1	156.5-47.4	2	158.5-44.1	1	166.2-53.2	2	168.3-51.0	1	170.3-53.1
1	179.5-53.1	2	194.4-55.3						
	87.0			17	8.0				
1	139.5-53.5	2	149.8-23.8	1	152.9-48.0	2	154.9-44.5	1	157.0-50.3
2	159.0-48.7	1	162.6-53.8						
	88.0			7	3.0				
1	112.3-52.8	1	134.4-50.0	2	149.8-16.8	1	156.0-49.0	2	160.1-47.3
1	168.3-51.8	2	169.8-50.1	1	172.9-52.9	1	177.0-53.5	2	184.2-47.6
1	188.8-53.8	1	193.9-52.7						
	89.0			12	4.0				
1	109.3-53.4	2	127.7-48.5	1	129.3-49.0	2	130.8-48.0	2	147.2-16.1
1	157.0-46.3	2	158.5-43.9	1	167.6-49.2	2	162.6-48.0	1	166.2-51.5
2	167.8-51.3	1	171.3-52.9	1	179.0-53.0	2	194.4-55.5		
	90.0			14	7.0				

CHART TITLE - SUBROUTINE OUTPUT

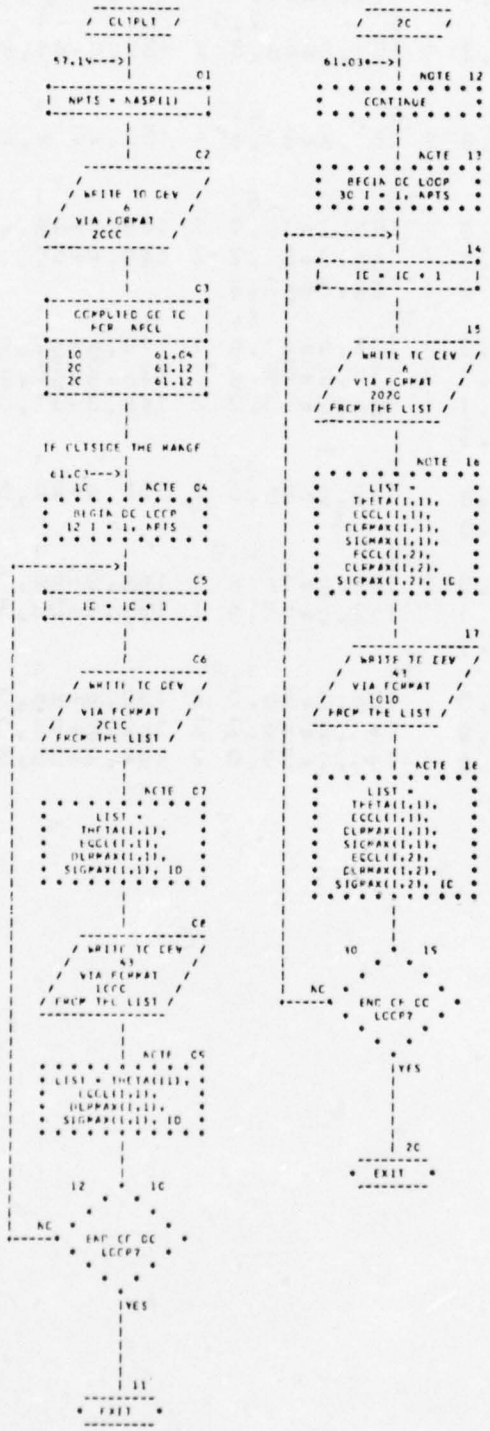

CASE 2: No. of polarizations = 2

<u>CARD 1</u>	<u>VARIABLE</u>	<u>COLUMNS</u>
	THETA	1-6
	EQCL (POL. 1)	11-15
	DLRMAX (POL. 1)	16-20
	SIGMAX (POL. 1)	21-25
	EQCL (POL. 2)	26-30
	DLRMAX (POL. 2)	31-35
	SIGMAX (POL. 2)	36-40

3.3.1.3.3 Calling Subroutine. Subroutine OUTPUT is called by the executive routine.

3.3.1.4 Listing

A complete listing of OUTPUT is contained in the following pages.

```

SUBROUTINE OUTPUT
COMMON/BLOCK1/ THETA(400,2),  EQCL(400,2),  DLRMAX(400,2),
1          SIGMAX(400,2)
C
C   COMMON/BLOCK4/NPOL,NASP(3),ID
C
C   NPTS = NASP(1)
C
C   WRITE (6,2000)
2000 FORMAT (///50H THETA  EQV  DLRMXV SIGMXV      ECH  DLRMXH SIGMH )
C
C   GO TO (10,20,20),NPOL
C
C   10 DO 12 I=1,NPTS
      ID = ID + 1
      WRITE(6,2010) THETA(I,1),EQCL(I,1),DLRMAX(I,1),SIGMAX(I,1),ID
2010 FORMAT( F6.1,F5.1,1X,2(1X,F6.1), 40X,      7H      P ,16)
      WRITE(43,1000)THETA(I,1),EQCL(I,1),DLRMAX(I,1),SIGMAX(I,1),ID
1000 FORMAT( F6.1,4X,3F5.1, 41X,      7H      P ,16)
C
C   12 CONTINUE
      RETURN
C
C   20 CONTINUE
      DO 30 I=1,NPTS
        ID = ID + 1
        WRITE(6,2020) THETA(I,1),EQCL(I,1),DLRMAX(I,1),SIGMAX(I,1),
1          EQCL(I,2),DLRMAX(I,2),SIGMAX(I,2),ID
2020 FORMAT( F6.1,F5.1,1X,2(1X,F6.1),2X,F5.1,1X,2(1X,F6.1),18X,7H
1          ,16)
        WRITE(43,1010)THETA(I,1),EQCL(I,1),DLRMAX(I,1),SIGMAX(I,1),
1          EQCL(I,2),DLRMAX(I,2),SIGMAX(I,2),ID
1010 FORMAT( F6.1,4X,6F5.1, 26X,      7H      P ,16)
C
C   30 CONTINUE
C
C   RETURN
      END

```

SECTION 4  
TEST DESCRIPTION

A test problem was run on the GE 635/645 computer for the purposes of debugging computer program DISCRM. A description of the test problem is presented in the following paragraphs.

4.1 INPUT DATA

A complete listing of the input data for the test problem is found in the following pages. The format of the data is described in Section 3.2.1.3.1.

Card 1

DBDOWN	28.0
RLOW	134.5
RHIGH	165.0

Card 2

THTID	Model 6/14 Two Spheres, One Jack
FREQ	9.0
NPOL	1
NBRTGT	1

Card 3

NWDS	450
THOLD	-52.8
IRO	200
THING	1.0
DRANG	0.51

Card 4

POLID	Vert/Vert
NASP	91
THETS	0.0
THETE	90.0
NVOID	0

Card 5

THETA	0.0
ICK	1
NPN	7
EC	3.0
IJPOL	1

Card 6

INPN(1)	1
RR(1)	122.6
SS(1)	-52.8
.	
.	
.	
INPN(NPN=5)	1
RR(NPN=5)	154.9
SS(NPN=5)	-51.8

Card 7

INPN(6)	2
RR(6)	162.6
SS(6)	-28.6
INPN(7)	1
RR(7)	164.7
SS(7)	-46.7

.

.

.

Card N

The input data of importance to DISCRM is:

1. Model 6/14 two spheres, one jack
2. One polarization: Vertical/Vertical
3. Peaks more than 28.0 dB below the maximum peak in the signature are to be ignored.
4. Only peaks between 134.5 and 165.0 inches are to be considered.
5. 91 aspect angles are to be considered: 0 to 90 degrees.

28.0	134.0	155.0	TWO SHP. RES, ONE JACK			9.00	1	1
MODFL 6/14	450	-52.8	200	1.0	0.51			
VERT/VERT	91	90.0	90.0					
0.0	1	7	3.0	1				
1 122.6-52.8	2 135.9-21.3	1 140.6-40.4	2 148.3-26.1	1 154.9-51.8				
2 162.6-28.6	1 164.7-+6.7	2 168.3-42.2	1 171.3-53.2					
1.0	1	7	3.0	1				
1 123.1-52.8	2 136.5-21.6	1 140.0-40.6	2 148.3-25.9	1 154.4-51.8				
2 163.1-29.4	1 164.2-+6.8	2 167.8-42.1	1 170.8-53.6					
2.0	1	7	3.0	1				
1 124.1-52.7	2 136.5-21.5	1 140.6-41.5	2 148.8-27.1	1 154.9-52.1				
2 162.6-31.0	1 165.2-+6.3	2 167.8-43.1	1 171.3-54.9					
3.0	1	7	3.0	1				
1 123.6-53.1	2 136.5-21.8	1 140.6-42.4	2 148.8-27.4	1 154.9-52.3				
2 161.1-35.6	1 164.7-+6.5	2 167.8-43.9	1 170.8-53.5					
4.0	1	11	5.0	1				
1 122.6-54.0	2 126.2-+9.5	1 127.7-49.6	2 137.0-22.6	1 140.6-42.6				
2 149.3-29.3	1 154.9-52.7	2 161.1-38.8	1 166.2-47.4	2 168.3-46.1				
1 170.8-53.6								
5.0	1	8	3.0	1				
1 124.1-52.9	2 135.9-22.0	1 141.1-43.5	2 147.7-30.3	1 154.4-53.3				
1 157.0-53.3	2 160.6-+5.7	1 170.3-53.9						
6.0	1	8	3.0	1				
1 123.6-53.7	2 136.5-21.8	1 141.1-44.4	2 148.3-31.3	1 154.4-53.9				
1 162.6-53.0	2 167.2-+9.6	1 159.8-53.8						
7.0	1	11	4.0	1				
1 125.2-54.0	2 136.5-21.9	1 141.6-45.4	2 148.3-32.5	1 154.4-53.4				
1 156.0-53.9	2 169.5-+5.9	1 162.1-53.4	1 166.2-53.5	2 171.3-55.2				
1 173.4-53.8								
8.0	1	7	3.0	1				
1 125.2-52.7	2 136.5-22.4	1 142.1-47.9	2 148.8-34.3	1 154.9-51.6				
2 159.5-41.6	1 169.3-52.9							
9.0	1	9	4.0	1				
1 125.2-52.8	2 136.5-22.1	1 142.6-50.8	2 148.3-35.5	1 154.9-50.3				
2 160.1-38.6	1 162.6-47.5	2 164.2-46.2	1 169.3-53.1					
10.0	1	7	3.0	1				
1 126.2-53.0	2 136.5-22.2	1 142.1-45.6	2 146.2-35.0	1 154.4-48.7				
2 159.5-36.2	1 168.8-53.0							
11.0	1	9	4.0	1				
1 125.7-54.4	2 136.5-21.6	1 141.1-43.8	2 148.3-32.7	1 153.9-48.4				
2 160.1-35.4	1 163.1-+8.8	2 164.7-48.0	1 169.8-53.9					
12.0	1	7	3.0	1				
1 127.2-53.2	2 136.5-21.9	1 140.6-42.7	2 148.3-32.6	1 154.4-48.4				
2 161.6-33.5	1 169.3-52.9							
13.0	1	7	3.0	1				
1 127.2-53.0	2 136.5-21.9	1 140.6-41.6	2 148.3-30.0	1 152.9-49.1				
2 161.1-32.3	1 168.3-54.7							
14.0	1	8	3.0	1				
1 126.2-53.1	2 136.5-21.7	1 140.6-41.8	2 147.7-29.0	1 153.9-50.8				
2 160.6-31.3	1 166.2-53.4	1 171.3-53.6						
15.0	1	8	3.0	1				
1 127.2-52.2	2 136.5-21.5	1 140.6-42.5	2 147.7-26.9	1 153.4-52.3				
1 153.9-52.5	2 161.1-29.1	1 166.7-53.3						
16.0	1	8	3.0	1				
1 126.7-52.9	2 137.0-21.8	1 140.6-45.5	2 148.8-25.9	1 152.9-52.8				
1 153.9-53.5	2 162.1-27.5	1 166.2-53.8						
17.0	1	7	3.0	1				
1 127.7-52.3	2 136.5-21.9	1 141.1-45.7	2 148.3-24.4	1 153.9-51.9				
2 161.1-26.7	1 166.7-53.1							

18.0	1	3	3.0	1
1 126.2-53.0	2 137.0-21.9	1 140.0-43.6	2 148.8-22.9	1 153.4-50.5
2 161.1-25.8	1 166.2-53.2	1 174.4-53.8		
19.0	1	11	4.0	1
1 121.1-53.6	1 125.7-53.1	2 136.5-20.8	1 140.6-42.8	2 147.7-21.4
1 153.4-48.2	2 160.6-24.7	1 166.7-52.9	1 171.3-52.8	2 172.9-49.0
1 175.4-54.7				
20.0	1	9	3.0	1
1 125.2-53.7	2 137.0-21.6	1 140.0-40.4	2 148.3-21.1	1 152.9-44.8
2 161.6-24.4	1 170.3-53.8	1 170.8-53.1	1 180.6-53.4	
21.0	1	8	3.0	1
1 117.5-53.3	2 136.5-21.7	1 140.0-38.5	2 147.2-20.9	1 152.4-43.7
2 160.6-24.6	1 178.0-54.0	1 183.7-53.1		
22.0	1	8	4.0	1
1 117.5-53.3	2 136.5-21.4	1 141.6-34.6	2 147.2-20.3	1 152.4-44.4
2 160.1-24.2	1 167.8-51.4	2 169.3-49.7		
23.0	1	15	6.0	1
1 112.9-53.0	2 114.4-51.7	1 117.0-52.8	1 117.5-53.0	2 120.0-50.8
1 127.2-51.7	2 137.0-21.2	1 142.6-34.9	2 147.7-19.6	1 152.9-46.5
2 160.6-23.3	1 167.8-53.0	1 168.8-53.2	2 173.4-47.4	1 175.4-52.9
24.0	1	13	5.0	1
1 115.9-53.3	2 136.5-21.8	1 142.1-36.1	2 147.7-20.1	1 152.4-46.6
2 160.6-22.5	1 169.3-52.8	1 170.3-53.1	2 172.4-47.5	1 177.0-52.9
1 180.1-54.1	2 182.6-50.9	1 185.2-53.6		
25.0	1	15	6.0	1
1 113.4-53.7	2 121.1-51.6	1 123.1-52.3	2 124.7-50.9	1 127.2-51.9
2 137.5-21.5	1 141.6-35.4	2 148.3-18.9	1 152.9-47.3	2 161.1-21.8
1 171.9-53.1	1 173.4-53.1	1 180.1-53.4	2 183.7-50.0	1 186.2-54.1
26.0	1	12	4.0	1
1 111.8-52.8	2 137.5-21.3	1 140.0-41.5	2 147.7-19.2	1 152.9-47.5
2 160.6-21.6	1 175.4-53.3	1 180.6-53.3	2 183.1-50.3	1 186.2-52.8
1 192.4-52.9	1 194.4-53.1			
27.0	1	19	8.0	1
1 112.3-52.8	1 119.0-52.7	1 119.5-53.0	2 122.1-50.4	2 137.5-21.1
1 139.5-41.4	2 147.7-18.6	1 151.3-43.4	2 160.6-22.2	2 171.3-48.7
1 174.4-54.4	1 176.5-52.9	2 178.0-50.3	1 180.6-53.7	1 181.6-52.9
2 183.7-50.0	1 187.2-52.6	2 189.8-51.3	1 192.4-53.3	
28.0	1	14	6.0	1
1 117.5-53.0	2 123.6-50.9	1 126.2-51.9	2 138.0-20.8	1 141.6-33.1
2 148.3-18.4	1 151.8-41.4	2 160.6-22.2	1 176.0-52.9	2 178.0-50.3
1 182.1-53.0	1 182.6-53.0	2 184.2-50.4	1 186.7-53.1	
29.0	1	14	6.0	1
1 114.4-52.9	2 120.0-50.6	1 123.1-51.7	2 137.5-21.2	1 142.1-33.6
2 147.7-19.8	1 152.4-41.1	2 160.1-23.2	1 167.2-50.5	2 170.3-49.0
1 173.4-53.0	1 181.6-53.0	2 184.7-51.3	1 186.7-53.1	
30.0	1	14	6.0	1
1 111.8-53.6	1 115.4-53.5	2 120.6-51.2	1 123.6-52.8	2 126.2-51.4
1 127.7-52.3	2 137.5-21.5	1 141.6-33.3	2 147.7-20.2	1 152.4-43.6
2 160.1-24.8	1 168.8-53.9	2 171.3-48.9	1 174.4-53.4	
31.0	1	11	4.0	1
1 117.0-53.5	2 120.6-51.5	1 122.6-52.2	2 137.5-21.0	1 142.1-34.3
2 147.7-21.8	1 151.8-44.3	2 160.1-24.7	1 166.2-53.6	1 168.8-53.1
1 172.9-53.0				
32.0	1	11	4.0	1
1 123.6-53.3	2 126.2-51.7	1 128.2-52.1	2 137.0-21.2	1 140.6-40.8
2 147.2-22.3	1 152.4-47.5	2 159.0-24.6	1 164.7-52.9	1 170.3-53.6
1 184.7-53.6				
33.0	1	13	5.0	1
1 119.0-53.8	2 120.6-52.4	1 123.1-53.2	1 125.7-53.1	2 137.5-21.1
1 140.6-40.9	2 147.7-22.5	1 151.8-45.7	2 159.5-25.7	1 166.7-52.9

1	169.3-52.8	2	176.0-54.7	1	178.0-53.5				
	34.0		1		3.0			1	
1	126.2-52.9	2	138.0-21.4	2	148.3-21.9	1	151.8-41.5	2	159.5-26.2
1	166.7-53.3								
	35.0		1	10	5.0			1	
1	119.5-53.1	2	126.2-50.6	1	127.7-51.1	2	138.0-20.9	1	141.6-32.8
2	147.7-22.0	1	152.4-40.8	2	159.0-26.0	2	170.3-49.0	1	173.4-53.6
	36.0		1	12	5.0			1	
1	117.5-53.1	2	124.7-51.0	1	126.7-51.7	2	138.0-20.6	1	142.1-32.8
2	147.7-21.2	1	151.8-43.7	2	159.0-25.7	1	165.7-53.3	1	168.3-54.6
2	170.3-49.8	1	172.4-53.1						
	37.0		1	13	6.0			1	
2	121.1-51.7	1	123.1-52.6	2	125.2-51.2	1	127.7-52.5	2	138.5-20.8
1	142.1-32.8	2	148.3-20.5	1	151.8-45.4	2	160.1-25.2	1	166.2-53.0
2	167.8-50.4	1	169.8-54.1	1	175.4-53.0				
	38.0		1	17	6.0			1	
1	115.9-52.9	1	122.1-52.7	2	138.5-20.8	1	142.1-36.5	2	147.7-20.3
1	151.8-45.3	2	159.0-24.0	1	163.6-49.9	2	165.2-48.3	1	169.3-51.5
1	173.9-53.7	1	181.6-53.3	2	183.7-51.6	1	186.2-52.9	1	187.2-53.1
2	189.8-50.0	1	192.9-53.1						
	39.0		1	11	4.0			1	
1	114.4-53.1	1	121.6-53.0	2	125.2-50.5	2	139.0-20.8	2	148.8-19.3
1	150.8-58.6	2	159.5-22.5	1	168.3-51.3	1	171.9-53.4	1	177.0-53.1
1	182.6-51.9								
	40.0		1	12	5.0			1	
1	109.3-52.9	2	125.7-50.4	1	128.8-51.3	2	139.0-20.4	1	142.6-31.9
2	148.3-19.2	1	151.3-57.4	2	159.0-22.6	1	167.8-51.2	2	170.3-47.5
1	172.9-53.4	1	179.0-53.5						
	41.0		1	15	6.0			1	
1	112.3-53.1	2	124.7-50.3	1	129.3-50.2	2	139.0-20.3	1	142.6-31.3
2	147.7-19.2	1	151.8-40.6	2	158.5-23.4	1	166.2-53.0	1	168.3-54.1
2	169.8-49.9	1	171.9-52.7	2	173.9-49.0	1	177.0-52.9	1	182.1-53.0
	42.0		1	11	6.0			1	
2	139.5-21.1	2	148.3-20.8	1	150.8-42.4	2	159.0-23.3	1	162.6-51.1
2	164.2-48.2	1	166.2-51.5	2	167.8-49.2	1	170.3-53.0	1	181.6-53.7
2	194.4-49.7								
	43.0		1	12	5.0			1	
1	121.6-51.8	2	139.5-20.7	2	148.3-20.8	1	151.3-40.6	2	158.5-23.4
1	162.1-47.3	2	164.7-46.7	1	173.9-52.7	2	176.0-50.5	1	178.5-53.1
1	182.6-52.8	1	188.8-52.6						
	44.0		1	10	4.0			1	
1	113.9-54.4	1	123.6-52.7	2	125.2-50.8	1	127.7-52.5	2	138.5-21.0
1	142.6-32.5	2	147.2-21.2	1	152.9-34.3	2	158.0-23.4	1	168.3-51.8
	45.0		1	10	4.0			1	
1	109.8-53.5	1	129.3-52.4	2	139.5-20.5	1	143.6-29.1	2	147.7-20.5
1	152.9-36.8	2	158.0-24.7	1	155.7-52.0	2	169.3-48.7	1	178.0-54.5
	46.0		1	13	6.0			1	
2	139.0-20.8	1	143.6-51.4	2	147.2-20.6	1	150.3-42.4	2	157.5-24.7
1	161.6-50.9	2	163.1-47.1	1	165.2-52.8	1	182.6-53.5	2	184.7-51.6
1	186.7-52.7	1	191.9-52.7	2	194.4-50.7				
	47.0		1	17	7.0			1	
1	115.4-53.9	2	117.0-51.8	1	119.5-53.3	2	121.1-51.9	1	123.6-53.5
2	139.5-20.9	2	147.7-20.3	1	150.8-42.6	2	157.5-24.4	1	161.6-50.9
2	163.6-46.7	1	167.2-52.5	1	173.4-53.1	1	184.2-53.0	1	187.8-53.2
2	190.3-51.6	1	193.4-53.3						
	48.0		1	12	5.0			1	
1	116.5-53.9	2	121.1-51.8	1	122.6-52.5	2	125.2-51.7	2	140.0-21.6
1	143.6-31.9	2	148.3-19.9	1	151.8-33.1	2	157.5-24.1	1	162.1-51.2
2	163.6-48.0	1	167.2-52.3						
	49.0		1	12	6.0			1	

1 112.3-53.3 2 114.4-51.3 2 127.2-50.1 1 128.8-51.3 2 140.0-20.7  
 1 143.1-27.7 2 147.7-14.4 1 152.9-33.5 2 157.5-23.5 1 164.2-52.8  
 2 168.3-49.2 1 176.5-53.2  
 50.0 1 17 7.0 1  
 2 118.5-51.1 1 121.1-52.7 2 122.6-50.9 1 125.2-51.8 2 139.0-20.4  
 1 143.1-28.9 2 147.2-19.1 1 150.3-40.1 2 156.5-23.2 1 161.1-50.0  
 2 163.1-45.7 1 165.7-53.0 1 169.3-53.9 1 175.4-53.7 1 186.7-53.7  
 1 189.3-53.2 2 193.9-50.0  
 51.0 1 17 7.0 1  
 1 115.4-53.3 2 118.0-52.2 1 119.5-53.1 2 140.0-20.9 2 147.2-20.3  
 1 151.8-36.7 2 157.0-23.1 1 161.1-51.3 2 163.1-48.1 1 166.7-51.6  
 1 173.4-53.7 2 175.4-51.5 1 178.0-53.5 1 181.6-53.2 1 188.8-53.5  
 2 190.3-50.8 1 194.9-53.3  
 52.0 1 11 5.0 1  
 1 116.5-52.9 2 124.7-50.7 2 140.6-21.4 1 143.6-30.5 2 148.3-20.4  
 1 152.4-31.8 2 157.0-23.3 1 156.7-50.2 2 168.3-49.1 1 170.3-52.5  
 1 178.5-53.1  
 53.0 1 10 3.0 1  
 1 115.9-52.4 1 119.5-51.7 1 129.8-51.7 2 140.0-20.9 1 143.6-27.0  
 2 147.2-20.3 1 152.9-52.6 2 156.5-23.7 1 162.6-52.8 1 178.0-53.9  
 54.0 1 17 7.0 1  
 1 115.4-53.2 2 124.7-50.8 1 129.3-51.9 2 141.1-21.0 1 144.2-28.1  
 2 147.2-21.1 1 149.8-43.5 2 156.5-24.3 2 162.6-47.1 1 165.2-53.0  
 1 168.8-53.3 1 176.0-53.9 1 182.6-53.5 2 186.2-53.5 1 188.3-53.6  
 1 188.8-53.5 2 193.4-49.5  
 55.0 1 11 5.0 1  
 2 121.1-51.5 1 123.6-52.5 2 140.0-20.6 2 147.2-20.4 1 149.3-40.1  
 2 156.0-24.3 2 167.8-50.2 1 169.8-53.4 1 179.5-53.2 2 182.6-53.3  
 1 184.7-53.7  
 56.0 1 12 5.0 1  
 1 118.0-53.2 2 121.1-51.5 1 123.6-52.3 2 127.2-51.2 1 129.8-52.3  
 2 141.1-21.1 1 144.2-27.9 2 148.3-19.9 1 152.4-30.5 2 156.5-23.8  
 1 170.3-53.0 1 171.9-52.8  
 57.0 1 17 7.0 1  
 1 112.3-53.1 2 116.5-51.3 2 124.1-50.5 1 126.7-51.8 2 141.1-20.9  
 1 144.2-24.9 2 147.2-20.1 1 152.4-31.9 2 155.4-25.4 1 164.7-53.0  
 1 168.8-54.4 2 170.3-50.0 1 172.4-53.4 1 174.4-53.7 2 176.0-50.6  
 1 179.5-53.7 1 194.4-52.3  
 58.0 1 16 7.0 1  
 1 115.4-52.9 2 119.5-51.4 2 129.8-50.5 1 131.3-51.9 2 141.6-20.6  
 1 144.7-26.4 2 148.3-19.2 2 156.5-23.6 1 160.1-50.9 2 161.6-48.2  
 1 166.2-53.2 1 166.7-53.1 1 181.6-52.9 1 186.2-53.4 1 186.7-53.0  
 2 191.3-48.2  
 59.0 1 14 6.0 1  
 1 114.4-53.2 2 115.9-52.3 1 118.0-52.8 1 118.5-52.9 2 141.6-21.3  
 2 147.7-19.9 1 151.3-29.9 2 155.4-23.4 1 159.5-50.6 2 161.1-47.9  
 1 165.7-52.6 1 176.5-53.0 2 179.0-52.0 1 181.6-53.0  
 60.0 1 14 6.0 1  
 1 112.3-53.4 1 119.5-52.5 2 122.1-50.5 1 127.7-51.1 2 142.1-20.5  
 1 144.7-24.3 2 148.3-19.1 1 151.8-27.4 2 156.0-22.8 1 162.1-50.9  
 2 166.2-48.9 1 171.9-52.7 2 173.4-50.0 1 175.4-52.7  
 61.0 1 17 7.0 1  
 1 111.8-54.0 2 124.7-50.8 2 142.1-20.6 1 144.7-23.7 2 147.7-20.5  
 1 150.8-33.2 2 154.9-23.8 1 160.1-49.5 2 161.6-47.3 1 164.2-52.5  
 1 167.8-53.2 1 175.4-53.7 2 177.5-50.9 1 179.5-53.2 1 182.6-53.4  
 1 187.8-53.0 2 191.9-49.8  
 62.0 1 9 4.0 1  
 1 116.5-52.9 2 120.6-51.0 1 122.1-51.5 2 142.1-21.4 1 145.2-28.8  
 2 148.3-20.9 2 155.4-24.3 1 166.2-52.6 1 177.5-53.1  
 63.0 1 12 5.0 1

1	113.4-53.5	1	117.5-52.8	2	142.6-21.7	1	144.7-27.0	2	147.7-20.1
1	151.3-29.2	2	155.4-23.3	1	159.5-49.2	2	161.1-46.7	1	162.6-50.4
2	164.7-49.4	1	168.8-53.8						
	64.0		1	19	7.0		1		
1	112.3-53.0	2	115.4-50.6	1	117.0-52.3	2	123.6-50.3	2	142.6-20.0
1	145.2-22.1	2	147.2-19.7	1	151.3-28.3	2	154.4-25.1	1	163.1-53.1
1	163.6-53.4	2	165.7-48.7	1	171.3-53.2	1	173.4-53.1	2	177.0-49.8
1	180.6-52.5	1	182.6-53.4	1	188.8-52.9	1	193.9-53.1		
	65.0		1	17	6.0		1		
1	119.5-53.7	1	120.0-53.3	1	127.7-52.7	1	131.8-53.6	2	142.6-20.4
1	144.7-23.5	2	147.7-20.2	1	150.8-32.6	2	154.4-25.0	1	165.2-53.4
1	177.0-54.7	2	179.5-50.7	1	182.1-53.1	2	184.7-51.4	1	188.3-53.3
1	189.3-53.6	2	191.9-50.8						
	66.0		1	10	5.0		1		
1	125.2-53.0	2	128.2-50.8	2	143.1-21.8	1	145.2-31.1	2	148.3-19.8
1	151.3-26.8	2	154.4-22.7	1	158.0-50.9	2	159.5-47.4	1	164.2-53.3
	67.0		1	11	5.0		1		
1	111.8-53.0	2	148.3-18.4	1	151.8-25.5	2	154.4-22.8	1	156.0-43.5
2	157.5-42.1	1	162.6-51.5	2	164.7-46.6	1	172.4-53.4	2	176.0-51.5
1	178.0-53.1								
	68.0		1	17	7.0		1		
1	113.9-53.4	1	118.0-52.6	2	129.3-50.5	1	132.4-51.3	2	144.2-19.3
1	151.8-33.2	2	154.9-24.2	1	160.6-50.8	2	162.1-47.1	1	164.2-52.6
1	177.5-52.8	2	179.5-51.0	1	181.6-52.5	2	184.2-50.2	1	187.8-52.5
2	189.8-50.4	1	193.4-51.3						
	69.0		1	11	5.0		1		
1	117.5-52.7	2	120.6-50.8	2	142.1-22.3	1	144.7-30.4	2	147.2-21.4
1	149.8-29.7	2	152.4-23.4	1	161.1-49.2	2	162.6-48.0	1	164.7-52.6
1	162.1-52.6								
	70.0		1	11	5.0		1		
1	113.9-52.9	2	130.8-50.0	1	132.4-50.5	2	144.2-20.4	1	145.7-21.5
2	147.2-19.4	1	151.8-25.1	2	153.9-22.9	1	163.1-50.6	2	165.7-46.2
1	172.4-53.1								
	71.0		1	14	6.0		1		
1	117.0-53.4	2	120.0-50.9	1	121.6-51.9	2	123.1-51.0	2	143.6-17.8
1	150.8-25.9	2	152.4-24.0	1	165.7-53.7	1	169.3-53.1	1	177.0-53.5
2	183.7-49.9	1	188.3-51.5	2	189.8-50.4	1	192.4-52.4		
	72.0		1	13	6.0		1		
1	115.4-53.1	2	130.3-50.1	2	143.6-22.8	1	145.2-25.7	2	147.7-21.9
1	150.3-30.8	2	152.9-24.7	2	161.6-47.9	1	165.7-53.1	1	169.3-52.0
1	178.5-53.4	2	182.4-55.2	1	184.4-53.4				
	73.0		1	13	5.0		1		
1	113.9-52.9	1	119.5-53.1	2	144.7-21.1	1	146.2-23.0	2	148.3-19.1
1	150.8-22.1	2	152.9-21.6	1	156.0-47.7	2	158.5-42.8	1	162.1-52.2
2	164.7-48.5	1	167.8-53.0	1	171.3-53.7				
	74.0		1	14	6.0		1		
1	113.9-53.9	2	115.9-52.4	1	117.5-52.7	2	122.1-51.1	1	126.2-51.6
2	145.7-17.1	1	151.3-25.7	2	152.9-25.7	1	160.5-52.6	2	163.6-50.6
1	165.2-53.3	1	179.0-53.6	2	184.2-50.6	1	186.2-52.7		
	75.0		1	11	4.0		1		
1	118.5-52.9	2	146.7-21.5	1	149.8-31.1	2	152.4-22.2	1	160.1-51.3
2	181.6-46.8	1	186.2-53.7	1	187.2-53.9	1	177.5-53.6	2	180.1-50.9
1	182.1-53.3								
	76.0		1	7	3.0		1		
1	119.5-52.9	2	148.3-20.9	1	150.8-23.7	2	152.4-23.1	1	161.6-50.6
2	164.2-48.8	1	166.2-53.1						
	77.0		1	14	5.0		1		
1	114.4-52.7	1	126.2-51.5	2	130.8-49.3	1	133.9-50.5	2	147.2-16.5
1	160.6-52.5	2	163.1-48.3	1	168.3-52.5	1	170.8-52.8	1	175.4-53.0
2	182.1-48.3	1	185.7-51.2	2	188.3-49.7	1	191.9-52.6		

78.0	1	3	3.0	1
1 120.0-53.4	2 146.2-13.9	2 152.4-26.7	1 159.0-50.9	2 161.1-49.2
1 164.7-53.6	1 167.2-53.2	1 183.1-53.4		
79.0	1	8	3.0	1
1 113.9-52.9	2 121.6-50.6	2 144.7-26.5	1 146.2-29.1	2 148.3-21.7
1 159.0-47.7	1 167.8-52.3	1 171.3-52.9		
80.0	1	15	6.0	1
1 111.8-53.6	2 122.6-49.3	1 129.3-50.8	2 132.4-49.6	1 135.9-49.9
2 146.7-15.7	1 160.6-50.7	2 162.6-48.7	1 172.4-53.3	1 176.5-53.7
2 183.7-49.0	1 186.2-52.3	2 188.3-52.1	1 190.3-53.3	1 192.9-53.2
81.0	1	15	6.0	1
1 120.6-53.1	2 123.6-53.8	1 125.7-53.3	2 131.3-51.2	1 134.4-52.8
2 146.7-18.1	1 149.8-29.5	2 151.8-25.3	1 155.4-48.9	2 157.5-45.9
1 164.7-53.2	1 166.7-55.4	1 179.5-53.1	2 182.1-51.3	1 184.7-53.8
82.0	1	9	4.0	1
1 119.5-53.1	2 128.2-51.0	1 131.3-52.0	2 145.2-30.2	1 146.7-34.5
2 151.3-23.7	1 158.0-51.5	2 162.1-49.2	1 164.7-52.8	
83.0	1	9	4.0	1
1 108.2-52.9	2 127.2-48.3	2 147.2-15.6	1 159.0-49.7	2 161.6-48.0
1 177.5-52.3	2 183.7-47.4	1 189.3-52.8	1 194.4-52.4	
84.0	1	6	2.0	1
1 120.0-53.0	2 146.7-17.3	1 157.5-46.5	2 159.0-45.8	1 167.8-53.1
1 181.1-53.4				
85.0	1	6	2.0	1
1 132.9-53.8	1 137.5-52.3	2 150.8-23.6	1 153.4-44.4	2 154.9-43.3
1 158.0-52.4				
86.0	1	13	6.0	1
1 110.3-53.5	2 123.6-43.9	2 147.2-15.9	1 159.0-48.4	2 161.6-46.7
1 164.7-50.4	2 166.2-49.7	1 158.3-51.2	2 169.8-50.1	1 173.4-53.0
1 178.0-52.7	2 183.1-48.2	1 188.3-52.0		
87.0	1	17	8.0	1
1 108.2-53.3	1 111.8-53.3	2 114.4-51.8	1 117.5-52.9	2 122.6-49.7
1 126.2-51.4	2 128.8-50.1	2 134.9-49.0	1 136.5-50.5	2 147.7-17.7
1 156.5-47.4	2 158.5-44.1	1 166.2-53.2	2 168.3-51.0	1 170.3-53.1
1 179.5-53.1	2 194.4-55.3			
88.0	1	7	3.0	1
1 139.5-53.5	2 149.8-23.3	1 152.9-40.0	2 154.9-44.5	1 157.0-50.3
2 159.0-48.7	1 162.6-53.3			
89.0	1	12	4.0	1
1 112.3-52.8	1 134.4-50.0	2 149.8-16.8	1 156.0-49.0	2 160.1-47.3
1 168.3-51.8	2 169.8-50.1	1 172.9-52.9	1 177.0-53.5	2 184.2-47.6
1 188.8-53.8	1 193.9-52.7			
90.0	1	14	7.0	1
1 109.3-53.4	2 127.7-48.5	1 129.3-49.0	2 130.8-48.0	2 147.2-16.1
1 157.0-46.3	2 158.5-43.9	1 160.6-49.2	2 162.6-48.0	1 166.2-51.5
2 167.8-50.3	1 171.3-52.9	1 179.0-53.0	2 194.4-55.5	

## 4.2 OUTPUT DATA

The output for the sample problem may be found in the following pages. The first part of the output is a listing of the input data. The second part is a listing of the resulting discriminants calculated from the input data. Only one polarization was examined (Vert/Vert). The listing contains the discriminants (1) equivalence class (ECV), (2) maximum separation between significant peaks in the signature (DLRMXV), and (3) maximum target radar cross section in the signature (SIGMXV) for each aspect angle (THETA) for Vert/Vert polarization. If two polarizations were examined the discriminants formed for the second polarization would have been listed in the appropriate columns.

SNUMR = 10251, ACTIVITY # = 02, REPORT CODE = 06, RECORD COUNT = 00451

MODEL 0/14 TWO SHPERES, ONE JACK 9.00 1 1 P 10003  
450 -52.8 200 1.0 0.51 P 10004  
CONSIDER ONLY PEAKS LESS THAN 28.0 DB DOWN AND BETWEEN 134.5 AND 165.0 IN P 10005  
VERT/VERT 91 0. 90.0 0  
0. 1 7 3.0 1  
1 122.6-52.8 2 135.9-21.8 1 140.6-40.4 2 148.3-26.1 1 154.9-51.8  
2 162.6-28.6 1 164.7-46.7  
1.0 1 7 3.0 1  
1 123.1-52.8 2 136.5-21.6 1 140.0-40.6 2 148.3-25.9 1 154.4-51.8  
2 163.1-29.4 1 164.2-46.8  
2.0 1 7 3.0 1  
1 124.1-52.7 2 136.5-21.5 1 140.6-41.5 2 148.8-27.1 1 154.9-52.1  
2 162.6-31.0 1 165.2-46.3  
3.0 1 7 3.0 1  
1 123.6-53.1 2 136.5-21.8 1 140.6-42.4 2 148.8-27.4 1 154.9-52.3  
2 161.1-35.6 1 164.7-46.5  
4.0 1 11 5.0 1  
1 122.6-54.0 2 126.2-49.5 1 127.7-49.8 2 137.0-22.6 1 140.6-42.6  
2 149.3-29.3 1 154.9-52.7 2 161.1-38.8 1 166.2-47.4 2 168.3-46.1  
1 170.8-53.6  
5.0 1 8 3.0 1  
1 124.1-52.9 2 135.9-22.0 1 141.1-43.5 2 147.7-30.3 1 154.4-53.3  
1 157.0-53.3 2 160.6-45.7 1 170.3-53.9  
6.0 1 8 3.0 1  
1 123.6-53.7 2 136.5-21.8 1 141.1-44.4 2 148.3-31.3 1 154.4-53.9  
1 162.6-53.0 2 167.2-49.6 1 169.3-53.8  
7.0 1 11 4.0 1  
1 125.2-54.0 2 136.5-21.9 1 141.6-45.4 2 148.3-32.5 1 154.4-53.4  
1 156.0-53.9 2 159.5-45.9 1 162.1-53.4 1 166.2-53.5 2 171.3-55.2  
1 173.4-53.8  
8.0 1 7 3.0 1  
1 125.2-52.7 2 136.5-22.4 1 142.1-47.9 2 148.8-34.3 1 154.9-51.6  
2 159.5-41.6 1 169.3-52.9  
9.0 1 9 4.0 1  
1 125.2-52.8 2 136.5-22.1 1 142.6-50.8 2 148.3-35.5 1 154.9-50.3  
2 160.1-38.6 1 162.6-47.5 2 164.2-46.2 1 169.3-53.1  
10.0 1 7 3.0 1  
1 126.2-53.0 2 136.5-22.2 1 142.1-45.6 2 146.2-35.0 1 154.4-48.7  
2 159.5-36.2 1 168.8-53.0  
11.0 1 9 4.0 1  
1 125.7-54.4 2 136.5-21.6 1 141.1-43.8 2 148.3-32.7 1 153.9-48.4  
2 160.1-35.4 1 163.1-48.5 2 164.7-48.0 1 169.8-53.9  
12.0 1 7 3.0 1  
1 127.2-53.2 2 136.5-21.9 1 140.6-42.7 2 148.3-32.6 1 154.4-46.4  
2 161.6-33.5 1 169.3-52.9  
13.0 1 7 3.0 1  
1 127.2-53.0 2 136.5-21.9 1 140.6-41.6 2 148.3-30.0 1 152.9-42.1  
2 161.1-32.3 1 168.3-54.7  
14.0 1 6 3.0 1  
1 126.2-53.1 2 136.5-21.7 1 140.6-41.8 2 147.7-29.0 1 153.9-50.8  
2 160.6-31.3 1 166.2-53.4 1 171.3-53.6  
15.0 1 6 3.0 1  
1 127.2-52.2 2 136.5-21.5 1 140.6-42.5 2 147.7-28.9 1 153.4-52.3  
1 153.9-52.5 2 161.1-29.1 1 166.7-53.3  
16.0 1 6 3.0 1  
1 126.7-52.9 2 137.0-21.8 1 140.6-45.5 2 148.8-25.9 1 152.9-52.8  
1 153.9-53.5 2 162.1-27.5 1 166.2-53.8  
17.0 1 7 3.0 1

1 127.7-52.3 2 136.5-21.9 1 141.1-45.7 2 148.3-24.4 1 153.9-51.9  
2 161.1-26.7 1 166.7-53.1  
18.0 1 8 3.0 1  
1 126.2-53.0 2 137.0-21.9 1 140.0-43.6 2 148.8-22.9 1 153.4-50.5  
2 161.1-25.8 1 166.2-53.2 1 174.4-53.8  
19.0 1 11 4.0 1  
1 121.1-53.6 1 125.7-53.1 2 136.5-20.8 1 140.6-42.8 2 147.7-21.4  
1 153.4-48.2 2 160.6-24.7 1 166.7-52.9 1 171.3-52.8 2 172.9-49.0  
1 175.4-54.7  
20.0 1 9 3.0 1  
1 125.2-53.7 2 137.0-21.6 1 140.0-40.4 2 148.3-21.1 1 152.9-44.8  
2 161.6-24.4 1 170.3-53.8 1 170.8-53.1 1 180.6-53.4  
21.0 1 8 3.0 1  
1 117.5-53.3 2 136.5-21.7 1 140.0-38.5 2 147.2-20.9 1 152.4-43.7  
2 160.6-24.6 1 178.0-54.0 1 183.7-53.1  
22.0 1 8 4.0 1  
1 117.5-53.3 2 136.5-21.4 1 141.6-34.6 2 147.2-20.3 1 152.4-44.4  
2 160.1-24.2 1 167.8-51.4 2 169.3-49.7  
23.0 1 15 6.0 1  
1 112.9-53.0 2 114.4-51.7 1 117.0-52.8 1 117.5-53.0 2 120.0-50.8  
1 127.2-51.7 2 137.0-21.2 1 142.6-34.9 2 147.7-19.6 1 152.9-46.5  
2 160.6-23.3 1 167.8-53.0 1 168.8-53.2 2 173.4-47.4 1 175.4-52.9  
24.0 1 13 5.0 1  
1 115.9-53.3 2 136.5-21.8 1 142.1-36.1 2 147.7-20.1 1 152.4-46.6  
2 160.6-22.5 1 169.3-52.8 1 170.3-53.1 2 172.4-47.5 1 177.0-52.9  
1 180.1-54.1 2 182.6-50.9 1 185.2-53.6  
25.0 1 15 6.0 1  
1 113.4-53.7 2 121.1-51.6 1 123.1-52.3 2 124.7-50.9 1 127.2-51.9  
2 137.5-21.5 1 141.6-35.4 2 146.3-18.9 1 152.9-47.3 2 161.1-21.8  
1 171.9-53.1 1 173.4-53.1 1 180.1-53.4 2 183.7-50.0 1 186.2-54.1  
26.0 1 12 4.0 1  
1 111.8-52.8 2 137.5-21.3 1 140.0-41.5 2 147.7-19.2 1 152.9-47.5  
2 160.6-21.6 1 175.4-53.3 1 180.6-53.3 2 183.1-50.3 1 186.2-50.8  
1 192.4-52.9 1 194.4-53.1  
27.0 1 19 6.0 1  
1 112.3-52.8 1 119.0-52.7 1 119.5-53.0 2 122.1-50.4 2 137.5-21.1  
1 139.5-41.4 2 147.7-18.6 1 151.3-43.4 2 160.6-22.2 2 171.3-48.7  
1 174.4-54.4 1 176.5-52.9 2 178.0-50.3 1 180.6-53.7 1 181.6-52.9  
2 183.7-50.0 1 187.2-52.6 2 189.8-51.3 1 192.4-53.3  
28.0 1 14 6.0 1  
1 117.5-53.0 2 123.6-50.9 1 126.2-51.9 2 138.0-20.6 1 141.6-33.1  
2 148.3-18.4 1 151.8-41.4 2 160.6-22.2 1 176.0-52.9 2 176.0-50.3  
1 182.1-53.0 1 182.6-53.0 2 184.2-50.4 1 186.7-53.1  
29.0 1 14 6.0 1  
1 114.4-52.9 2 120.0-50.6 1 123.1-51.7 2 137.5-21.2 1 142.1-33.6  
2 147.7-19.8 1 152.4-41.1 2 160.1-23.2 1 167.2-50.5 2 170.3-49.0  
1 173.4-53.0 1 181.6-53.0 2 184.7-51.3 1 186.7-53.1  
30.0 1 14 6.0 1  
1 111.8-53.6 1 115.4-53.5 2 120.6-51.2 1 123.6-52.8 2 125.2-51.4  
1 127.7-52.3 2 137.5-21.5 1 141.6-33.3 2 147.7-20.2 1 152.4-43.6  
2 160.1-24.8 1 168.8-53.9 2 171.3-48.9 1 174.4-53.4  
31.0 1 11 4.0 1  
1 117.0-53.5 2 120.6-51.5 1 122.6-52.2 2 137.5-21.0 1 142.1-34.3  
2 147.7-21.8 1 151.8-44.3 2 160.1-24.7 1 166.2-53.6 1 168.3-33.1  
1 172.9-53.0  
32.0 1 11 4.0 1  
1 123.6-53.3 2 126.2-51.7 1 123.2-52.1 2 137.0-21.2 1 140.6-40.8  
2 147.2-22.3 1 152.4-47.5 2 159.0-24.6 1 164.7-52.9 1 170.3-53.6  
1 184.7-53.6

33.0	1	13	5.0	1
1 119,0-53,8	2 120,6-52,4	1 123,1-53,2	1 125,7-53,1	2 137,5-21,1
1 140,6-40,9	2 147,7-22,5	1 151,8-45,7	2 159,5-25,7	1 166,7-22,9
1 169,3-52,8	2 176,0-54,7	1 178,0-53,5		
34.0	1	6	3.0	1
1 126,2-52,9	2 138,0-21,4	2 148,3-21,9	1 151,8-41,5	2 157,5-26,2
1 166,7-53,3				
35.0	1	10	5.0	1
1 119,5-53,1	2 126,2-50,6	1 127,7-51,1	2 138,0-20,9	1 141,6-32,8
2 147,7-22,0	1 152,4-40,8	2 159,0-26,0	2 170,3-49,0	1 173,4-23,6
36.0	1	12	5.0	1
1 117,5-53,1	2 124,7-51,0	1 126,7-51,7	2 138,0-20,6	1 142,1-32,8
2 147,7-21,2	1 151,8-43,7	2 159,0-25,7	1 165,7-53,3	1 168,3-24,6
2 170,3-49,8	1 172,4-53,1			
37.0	1	13	6.0	1
2 121,1-51,7	1 123,1-52,6	2 125,2-51,2	1 127,7-52,5	2 138,5-20,8
1 142,1-32,8	2 148,3-20,5	1 151,8-45,4	2 160,1-25,2	1 166,2-23,0
2 167,8-50,4	1 169,8-54,1	1 175,4-53,0		
38.0	1	17	6.0	1
1 115,9-52,9	1 122,1-52,7	2 138,5-20,8	1 142,1-36,5	2 147,7-20,3
1 151,8-45,3	2 159,0-24,0	1 163,6-49,9	2 165,2-48,3	1 169,3-21,5
1 173,9-53,7	1 181,6-53,3	2 183,7-51,6	1 186,2-52,9	1 187,2-53,1
2 189,8-50,0	1 192,9-53,1			
39.0	1	11	4.0	1
1 114,4-53,1	1 121,6-53,0	2 125,2-50,5	2 139,0-20,8	2 143,8-19,3
1 150,8-38,6	2 159,5-22,5	1 168,3-51,3	1 171,9-53,4	1 177,0-53,1
1 182,6-51,9				
40.0	1	12	5.0	1
1 109,3-52,9	2 125,7-50,4	1 128,8-51,3	2 139,0-20,4	1 142,6-31,9
2 148,3-19,2	1 151,3-37,4	2 159,0-22,6	1 167,8-51,2	2 170,3-47,5
1 172,9-53,4	1 179,0-53,5			
41.0	1	15	6.0	1
1 112,3-53,1	2 124,7-50,3	1 129,3-50,2	2 139,0-20,3	1 142,6-31,3
2 147,7-19,2	1 151,8-40,6	2 158,5-23,4	1 166,2-53,0	1 168,3-54,1
2 169,8-49,9	1 171,9-52,7	2 173,9-49,0	1 177,0-52,9	1 182,1-53,0
42.0	1	11	6.0	1
2 139,5-21,1	2 148,3-20,8	1 150,8-42,4	2 159,0-23,3	1 162,6-21,1
2 164,2-48,2	1 166,2-51,5	2 167,8-49,2	1 170,3-53,0	1 181,6-23,7
2 194,4-49,7				
43.0	1	12	5.0	1
1 121,6-51,8	2 139,5-20,7	2 148,3-20,8	1 151,3-40,6	2 156,5-23,4
1 162,1-47,3	2 164,7-46,7	1 173,9-22,7	2 176,0-50,5	1 178,2-53,1
1 182,6-52,8	1 183,8-52,6			
44.0	1	10	4.0	1
1 113,9-54,4	1 123,5-52,7	2 125,2-20,8	1 127,7-52,5	2 138,5-21,0
1 142,6-32,5	2 147,2-21,2	1 152,9-34,3	2 158,0-23,4	1 166,3-21,8
45.0	1	10	4.0	1
1 109,8-53,5	1 129,3-52,4	2 139,5-20,5	1 143,6-29,1	2 147,7-20,5
1 152,9-36,8	2 158,0-24,7	1 166,7-52,0	2 169,3-48,7	1 173,0-24,5
46.0	1	13	6.0	1
2 139,0-20,8	1 143,6-31,4	2 147,2-20,6	1 150,3-42,4	2 157,2-24,7
1 161,6-50,9	2 163,1-47,1	1 165,2-52,8	1 182,6-53,5	2 184,7-51,6
1 186,7-52,7	1 191,9-52,7	2 194,4-50,7		
47.0	1	17	7.0	1
1 115,4-53,9	2 117,0-51,8	1 119,5-53,3	2 121,1-51,9	1 123,6-53,5
2 139,5-20,9	2 147,7-20,3	1 150,8-42,6	2 157,5-24,4	1 161,6-50,9
2 163,6-46,7	1 167,2-22,5	1 173,4-53,1	1 184,2-53,0	1 187,8-53,2
2 190,3-51,0	1 193,4-53,3			
48.0	1	12	6.0	1

1 110.5-53.9 2 121.1-51.8 1 122.6-52.5 2 125.2-51.7 2 140.0-21.6  
1 143.6-51.9 2 148.3-19.9 1 151.8-53.1 2 157.5-24.1 1 162.1-51.2  
2 163.6-48.0 1 167.2-52.9  
49.0 1 12 6.0 1  
1 112.3-53.3 2 114.4-51.3 2 127.2-50.1 1 128.8-51.3 2 140.0-20.7  
1 143.1-27.7 2 147.7-18.4 1 152.9-53.5 2 157.5-23.5 1 164.2-52.8  
2 168.3-49.2 1 176.5-53.2  
50.0 1 17 7.0 1  
2 118.5-51.1 1 121.1-52.7 2 122.6-50.9 1 125.2-51.8 2 132.0-20.4  
1 143.1-28.9 2 147.2-19.1 1 150.3-40.1 2 156.5-23.2 1 161.1-50.0  
2 163.1-45.7 1 165.7-53.0 1 169.3-53.9 1 175.4-53.7 1 186.7-53.7  
1 189.3-53.2 2 193.9-50.0  
51.0 1 17 7.0 1  
1 115.4-53.3 2 118.0-52.2 1 119.5-53.1 2 140.0-20.9 2 147.2-20.3  
1 151.8-36.7 2 157.0-23.1 1 161.1-51.3 2 163.1-48.1 1 166.7-51.6  
1 173.4-53.7 2 175.4-51.5 1 178.0-53.5 1 181.6-53.2 1 183.8-53.5  
2 190.3-50.8 1 194.9-53.3  
52.0 1 11 5.0 1  
1 116.5-52.9 2 124.7-50.7 2 140.6-21.4 1 143.6-30.5 2 146.3-20.4  
1 152.4-31.8 2 157.0-23.3 1 166.7-50.2 2 168.3-49.1 1 170.3-52.5  
1 178.5-53.1  
53.0 1 10 3.0 1  
1 115.9-52.4 1 119.5-51.7 1 129.8-51.7 2 140.0-20.9 1 145.6-27.0  
2 147.2-20.3 1 152.9-32.6 2 156.5-23.7 1 162.6-52.8 1 178.0-53.2  
54.0 1 17 7.0 1  
1 115.4-53.2 2 124.7-50.8 1 129.3-51.9 2 141.1-21.0 1 144.2-28.1  
2 147.2-21.1 1 149.8-43.5 2 156.5-24.3 2 162.6-47.1 1 165.2-53.0  
1 168.8-53.3 1 176.0-53.9 1 182.6-53.5 2 186.2-53.5 1 188.3-53.6  
1 188.8-53.5 2 193.4-49.5  
55.0 1 11 6.0 1  
2 121.1-51.5 1 123.6-52.5 2 140.0-20.6 2 147.2-20.4 1 149.3-40.1  
2 156.0-24.3 2 167.8-50.2 1 169.8-53.4 1 179.5-53.2 2 182.6-53.3  
1 184.7-53.7  
56.0 1 12 5.0 1  
1 118.0-53.2 2 121.1-51.5 1 123.6-52.3 2 127.2-51.2 1 129.8-52.3  
2 141.1-21.1 1 144.2-27.9 2 146.3-19.9 1 152.4-30.5 2 156.5-23.8  
1 170.3-53.0 1 171.9-52.8  
57.0 1 17 7.0 1  
1 112.3-53.1 2 116.5-51.3 2 124.1-50.5 1 126.7-51.8 2 141.1-20.9  
1 144.2-24.9 2 147.2-20.1 1 152.4-31.9 2 155.4-25.4 1 164.7-53.0  
1 168.8-54.4 2 170.3-50.0 1 172.4-53.4 1 174.4-53.7 2 176.0-50.6  
1 179.5-53.7 1 194.4-52.3  
58.0 1 16 7.0 1  
1 115.4-52.9 2 119.5-51.4 2 129.8-50.5 1 131.3-51.9 2 141.6-20.6  
1 144.7-26.4 2 148.3-19.2 2 156.5-23.6 1 160.1-50.9 2 161.6-46.2  
1 166.2-53.2 1 166.7-53.1 1 181.6-52.9 1 186.2-53.4 1 188.7-53.0  
2 191.3-48.2  
59.0 1 14 6.0 1  
1 114.4-53.2 2 115.9-52.3 1 118.0-52.8 1 118.5-52.9 2 141.6-21.3  
2 147.7-19.9 1 151.3-25.9 2 155.4-23.4 1 159.5-50.6 2 161.1-47.9  
1 165.7-52.6 1 176.5-53.0 2 179.0-52.0 1 181.6-53.0  
60.0 1 14 5.0 1  
1 112.3-53.4 1 119.5-52.5 2 122.1-50.5 1 127.7-51.1 2 142.1-20.5  
1 144.7-24.3 2 148.3-19.1 1 151.8-27.4 2 156.0-22.8 1 162.1-50.8  
2 166.2-48.9 1 171.9-52.7 2 173.4-50.6 1 175.4-52.7  
61.0 1 17 7.0 1  
1 111.8-54.0 2 124.7-50.8 2 142.1-20.6 1 144.7-23.7 2 147.7-20.8  
1 150.8-53.2 2 154.0-23.5 1 160.1-49.5 2 161.6-47.3 1 164.2-50.8  
1 167.8-53.2 1 175.4-53.7 2 177.5-50.9 1 179.5-53.2 1 182.6-53.3

AD-A033 709

PRC INFORMATION SCIENCES CO ROME N Y  
SPACE SURVEILLANCE SOFTWARE SUPPORT. VOLUME III. RADAR SIGNATUR--ETC(U)  
OCT 76 P R CONTI

F/6 15/3

F30602-75-C-0167

UNCLASSIFIED

RADC-TR-76-261-VOL-3

NL

2 OF 3  
AD  
A033709



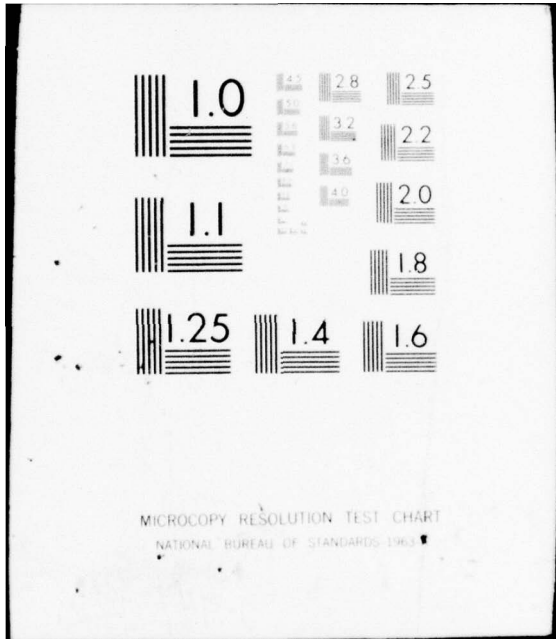

MICROCOPY RESOLUTION TEST CHART  
NATIONAL BUREAU OF STANDARDS-1963-A

1 187,8-53,0 2 191,9-49,8  
62,0 1 9 4,0 1  
1 116,5-52,9 2 120,6-51,0 1 122,1-51,5 2 142,1-21,4 1 145,2-28,8  
2 148,3-20,9 2 155,4-24,3 1 166,2-52,6 1 177,5-53,1  
63,0 1 12 5,0 1  
1 113,4-53,5 1 117,5-52,8 2 142,6-21,7 1 144,7-27,0 2 147,7-20,1  
1 151,3-29,2 2 155,4-23,3 1 159,5-49,2 2 161,1-46,7 1 162,9-50,4  
2 164,7-49,4 1 168,8-53,8  
64,0 1 19 7,0 1  
1 112,3-53,0 2 115,4-50,6 1 117,0-52,3 2 123,6-50,3 2 142,6-20,0  
1 145,2-22,1 2 147,2-19,7 1 151,3-28,3 2 154,4-25,1 1 163,1-53,1  
1 163,6-53,4 2 165,7-48,7 1 171,3-53,2 1 173,4-53,1 2 177,0-49,8  
1 180,6-52,5 1 182,6-53,4 1 188,8-52,9 1 193,9-53,1  
65,0 1 17 6,0 1  
1 119,5-53,7 1 120,0-53,3 1 127,7-52,7 1 131,8-53,6 2 142,6-20,4  
1 144,7-23,5 2 147,7-20,2 1 150,8-32,6 2 154,4-25,0 1 165,2-53,4  
1 177,0-54,7 2 179,5-50,7 1 182,1-53,1 2 184,7-51,4 1 188,3-53,3  
1 189,3-53,6 2 191,9-50,8  
66,0 1 10 5,0 1  
1 125,2-53,0 2 126,2-50,8 2 143,1-21,8 1 145,2-31,1 2 148,3-19,8  
1 151,3-26,8 2 154,4-22,7 1 158,0-50,9 2 159,5-47,4 1 164,2-53,3  
67,0 1 11 5,0 1  
1 111,8-53,0 2 148,3-18,4 1 151,8-25,5 2 154,4-22,8 1 156,0-43,5  
2 157,5-42,1 1 162,6-51,5 2 164,7-46,6 1 172,4-53,4 2 176,0-51,5  
1 178,0-53,1  
68,0 1 17 7,0 1  
1 113,9-53,4 1 118,0-52,6 2 129,3-50,5 1 132,4-51,3 2 144,2-19,3  
1 151,8-33,2 2 154,9-24,2 1 160,6-50,8 2 162,1-47,1 1 164,2-52,6  
1 177,5-52,8 2 179,5-51,0 1 181,6-52,5 2 184,2-50,2 1 187,8-52,5  
2 189,8-50,4 1 193,4-51,3  
69,0 1 11 5,0 1  
1 117,5-52,7 2 120,6-50,8 2 142,1-22,3 1 144,7-30,4 2 147,2-21,4  
1 149,8-29,7 2 152,4-23,4 1 161,1-49,2 2 162,6-48,0 1 164,7-52,6  
1 182,1-52,6  
70,0 1 11 5,0 1  
1 113,9-52,9 2 130,8-50,0 1 132,4-50,5 2 144,2-20,4 1 145,7-21,5  
2 147,2-19,4 1 151,8-25,1 2 153,9-22,9 1 163,1-50,6 2 165,7-46,2  
1 172,4-53,1  
71,0 1 14 6,0 1  
1 117,0-53,4 2 120,0-50,9 1 121,6-51,9 2 123,1-51,0 2 143,6-17,8  
1 150,8-25,9 2 152,4-24,0 1 165,7-53,7 1 169,3-53,1 1 177,0-53,5  
2 183,7-49,9 1 188,3-51,5 2 189,8-50,4 1 192,4-52,4  
72,0 1 13 6,0 1  
1 115,4-53,1 2 130,3-50,0 2 143,6-22,8 1 145,2-25,7 2 147,7-21,9  
1 150,3-30,8 2 152,9-24,7 2 161,6-47,9 1 165,7-53,1 1 169,3-52,6  
1 178,5-53,4 2 192,4-55,2 1 194,4-53,4  
73,0 1 13 5,0 1  
1 113,9-52,9 1 119,5-53,1 2 144,7-21,1 1 146,2-23,0 2 149,3-19,1  
1 150,8-22,1 2 152,9-21,6 1 156,0-47,7 2 158,5-42,8 1 162,1-52,2  
2 164,7-48,5 1 167,8-53,0 1 171,3-53,7  
74,0 1 14 6,0 1  
1 113,9-53,9 2 115,9-52,4 1 117,5-52,7 2 122,1-51,1 1 126,2-51,6  
2 145,7-17,1 1 151,3-26,7 2 152,9-25,7 1 160,6-52,6 2 163,6-50,6  
1 165,2-53,3 1 179,0-53,6 2 184,2-50,6 1 186,2-52,7  
75,0 1 11 4,0 1  
1 118,5-52,9 2 146,7-21,5 1 149,8-31,1 2 152,4-22,2 1 160,1-51,3  
2 161,6-46,8 1 165,2-53,7 1 167,2-53,9 1 177,5-53,6 2 180,1-50,9  
1 182,1-53,3  
76,0 1 7 3,0 1

1	119.5-52.9	2	148.3-20.9	1	150.8-23.7	2	152.4-23.1	1	161.6-50.6
2	164.2-48.8	1	166.2-53.1						
	77.0		1	14	5.0		1		
1	114.4-52.7	1	126.2-51.5	2	130.8-49.3	1	133.9-50.5	2	147.2-16.5
1	160.6-52.5	2	163.1-48.3	1	165.3-52.5	1	170.8-52.8	1	175.4-53.0
2	182.1-48.3	1	185.7-51.2	2	183.3-49.7	1	191.9-52.6		
	78.0		1	6	3.0		1		
1	120.0-53.4	2	146.2-19.9	2	152.4-26.7	1	159.0-50.9	2	161.1-49.2
1	164.7-53.6	1	167.2-53.2	1	183.1-53.4				
	79.0		1	8	3.0		1		
1	113.9-52.9	2	121.6-50.6	2	144.7-26.5	1	146.2-29.1	2	148.5-21.7
1	159.0-47.7	1	167.8-52.8	1	171.3-52.9				
	80.0		1	15	6.0		1		
1	111.8-53.6	2	122.6-49.3	1	129.3-50.8	2	132.4-49.6	1	135.9-49.9
2	146.7-15.7	1	160.6-50.7	2	162.6-48.7	1	172.4-53.3	1	176.5-53.7
2	183.7-49.0	1	186.2-52.3	2	188.3-52.1	1	190.3-53.3	1	192.9-53.2
	81.0		1	15	6.0		1		
1	120.6-53.1	2	123.6-53.8	1	125.7-53.3	2	131.3-51.2	1	134.4-52.8
2	146.7-18.1	1	149.8-29.5	2	151.8-25.3	1	155.4-48.9	2	157.5-45.9
1	164.7-53.2	1	166.7-55.4	1	179.5-53.1	2	182.1-51.3	1	184.7-53.8
	82.0		1	9	4.0		1		
1	119.5-53.1	2	128.2-51.0	1	131.3-52.6	2	145.2-30.2	1	146.7-34.5
2	151.3-23.7	1	158.0-51.5	2	162.1-49.2	1	164.7-52.8		
	83.0		1	9	4.0		1		
1	108.2-52.9	2	127.2-48.9	2	147.2-15.6	1	159.0-49.7	2	161.6-48.0
1	177.5-52.3	2	183.7-47.4	1	189.3-52.8	1	194.4-52.4		
	84.0		1	6	2.0		1		
1	120.0-53.0	2	146.7-17.3	1	157.5-46.5	2	159.0-45.8	1	167.8-53.1
1	181.1-53.4								
	85.0		1	6	2.0		1		
1	132.9-53.8	1	137.5-52.8	2	150.8-23.6	1	153.4-44.4	2	154.9-43.3
1	158.0-52.4								
	86.0		1	13	6.0		1		
1	110.3-53.5	2	123.6-48.9	2	147.2-15.9	1	159.0-48.4	2	161.6-46.7
1	164.7-50.4	2	166.2-49.7	1	168.3-51.2	2	169.8-50.1	1	173.4-53.0
1	178.0-52.7	2	183.1-48.2	1	188.3-52.6				
	87.0		1	17	8.0		1		
1	108.2-53.3	1	111.8-53.3	2	114.4-51.9	1	117.5-52.9	2	122.6-49.7
1	126.2-51.4	2	128.8-50.1	2	134.7-49.6	1	136.5-50.5	2	147.7-17.7
1	156.5-47.4	2	158.5-44.1	1	166.2-53.2	2	168.3-51.0	1	170.3-53.1
1	179.5-53.1	2	194.4-55.3						
	88.0		1	7	3.0		1		
1	139.5-53.5	2	149.8-23.8	1	152.9-48.0	2	154.9-44.5	1	157.0-50.3
2	159.0-48.7	1	162.6-53.8						
	89.0		1	12	4.0		1		
1	112.3-52.8	1	134.4-50.0	2	149.8-16.8	1	156.0-49.0	2	160.1-47.3
1	168.3-51.8	2	169.8-50.1	1	172.9-52.9	1	177.0-53.5	2	184.2-47.6
1	188.8-53.8	1	193.9-52.7						
	90.0		1	14	7.0		1		
1	109.3-53.4	2	127.7-48.5	1	129.3-49.0	2	130.8-48.0	2	147.2-16.1
1	157.0-46.3	2	158.5-43.9	1	160.6-49.2	2	162.6-48.0	1	166.2-51.5
2	167.8-50.3	1	171.3-52.9	1	179.0-53.0	2	194.4-55.5		

3.0	3.0	24.6	-21.8
4.0	3.0	24.1	-22.6
5.0	3.0	24.7	-22.0
6.0	2.0	11.8	-21.8
7.0	3.0	23.0	-21.9
8.0	3.0	23.0	-22.4
9.0	4.0	27.7	-22.1
10.0	3.0	23.0	-22.2
11.0	4.0	28.2	-21.6
12.0	3.0	25.1	-21.9
13.0	3.0	24.6	-21.9
14.0	3.0	24.1	-21.7
15.0	3.0	24.6	-21.5
16.0	3.0	25.1	-21.8
17.0	3.0	24.6	-21.9
18.0	3.0	24.1	-21.9
19.0	3.0	24.1	-20.8
20.0	3.0	24.6	-21.1
21.0	3.0	24.1	-20.9
22.0	3.0	23.6	-20.3
23.0	3.0	23.6	-19.6
24.0	3.0	24.1	-20.1
25.0	3.0	23.6	-18.9
26.0	3.0	23.1	-19.2
27.0	3.0	23.1	-18.6
28.0	3.0	22.6	-18.4
29.0	3.0	22.6	-19.8
30.0	3.0	22.5	-20.2
31.0	3.0	22.6	-21.0
32.0	3.0	22.0	-21.2
33.0	3.0	22.0	-21.1
34.0	3.0	21.5	-21.4
35.0	3.0	21.0	-20.9
36.0	3.0	21.0	-20.6
37.0	3.0	21.6	-20.5
38.0	3.0	20.5	-20.3
39.0	3.0	20.5	-19.3
40.0	3.0	20.0	-19.2
41.0	3.0	19.5	-19.2
42.0	4.0	24.7	-20.8
43.0	4.0	25.2	-20.7
44.0	3.0	19.5	-21.0
45.0	3.0	18.5	-20.5
46.0	4.0	24.1	-20.6
47.0	4.0	24.1	-20.3
48.0	3.0	17.5	-19.9
49.0	3.0	17.5	-18.4
50.0	4.0	24.1	-19.1
51.0	4.0	23.1	-20.3
52.0	3.0	16.4	-20.4
53.0	3.0	16.5	-20.3
54.0	4.0	21.5	-21.0
55.0	3.0	16.0	-20.4
56.0	3.0	15.4	-19.9
57.0	3.0	14.3	-20.1
58.0	4.0	20.0	-19.2
59.0	4.0	19.5	-19.9
60.0	3.0	13.9	-19.1
61.0	4.0	19.5	-20.5

62.0	3.0	13.3	-20.9
63.0	4.0	13.5	-20.1
64.0	3.0	11.8	-19.7
65.0	3.0	11.8	-20.2
66.0	4.0	10.4	-19.6
67.0	3.0	9.2	-18.4
68.0	3.0	17.9	-19.3
69.0	4.0	20.5	-21.4
70.0	3.0	9.7	-19.4
71.0	2.0	8.8	-17.8
72.0	4.0	13.0	-21.9
73.0	4.0	13.8	-19.1
74.0	2.0	7.2	-17.1
75.0	3.0	14.9	-21.5
76.0	3.0	15.9	-20.9
77.0	1.0	0.	-16.5
78.0	2.0	6.2	-19.9
79.0	2.0	3.6	-21.7
80.0	1.0	0.	-15.7
81.0	3.0	10.8	-18.1
82.0	3.0	15.9	-23.7
83.0	1.0	0.	-15.6
84.0	1.0	0.	-17.3
85.0	2.0	4.1	-23.6
86.0	1.0	0.	-15.9
87.0	2.0	10.8	-17.7
88.0	3.0	9.2	-23.8
89.0	1.0	0.	-15.8
90.0	2.0	11.3	-18.1

SECTION IV

SIGNATURE SUPERPOSITION PROGRAM  
A36 DOCUMENTATION

TABLE OF CONTENTS

<u>Section</u>	<u>Title</u>	<u>Page</u>
1	General	95
2	Abstract	95
3	Machine Definition	95
4	Program Description	95
	4.1 Main Program	95
	4.2 Subroutine READT	
	4.3 Subroutine FLFXR	
	4.4 Subroutine EXEC	
	4.5 Subroutine PL4020	
	4.6 Subroutine OUTPR(6)	
	4.7 Subroutine OUTPR(8)	
	4.8 Subroutine ZEROS	
5	Flow Chart Diagrams	96
6	Instructions to Customer	98
	6.1 Input Data	98
	6.1.1 Library Data	
	6.1.2 Problem Data	
	6.2 Output Data	103
	6.2.1 Magnetic Tape	
	6.2.2 Printed Output	
7	A36 FORTRAN IV Listing	105
8	Sample Problem	120
	8.1 Description	
	8.2 Input Data	
	8.3 Output Data	

## SIGNATURE SUPERPOSITION PROGRAM

### A36 Documentation

1. General. This exhibit is a documentation of Electronic Data Processing (EDP) Program A36, Signature Superposition Program, produced under Contract AF30(602)-67-0074 for RADC by the Fort Worth Division of General Dynamics. EDP program A36 was originally written for use with an IBM 7040-7090 direct coupled system; however, in this documentation the necessary changes have been incorporated to make the program compatible with the GE 625/635 computer at RADC. This documentation has been prepared in accordance with Electronic Data Processing (EDP) Programs and Program Documentation, Requirements for Preparation of, Exhibit RADC-3010 of 17 January 1964.

2. Abstract. The purpose of this procedure is to perform the analytic superposition of various generic radar targets using measured scattering data. The superposition of these generic shapes produces synthesized cross section and phase data for a composite radar target. The library data processed by this procedure is obtained from magnetic tapes produced by procedure A24. The output of A36 can be obtained on magnetic tape and on a printed listing.

3. Machine Definition. The enclosed documentation is written in Fortran IV language using an IBM character set. This documentation is specifically designed for use with the GE 625/635 computer at RADC.

4. Program Description. Figure 1 contains a simplified logic diagram of A36. Basically, the program consists of a main program and a set of subroutines. These divisions are described below.

4.1 Main Program. The main program is used to call problems and subroutines and to assign the correct unit designations to each of the three library tapes which may be used as input.

4.2 Subroutine READT. This subroutine is used to read cross section, phase, and azimuth data from the library tapes.

4.3 Subroutine FLFXR. This subroutine is used to convert the fixed point library data to floating point for use in the main computations, and to convert composite cross section, phase, and azimuth data back to fixed point for output.

**4.4 Subroutine EXEC.** This subroutine processes and accumulates cross section and phase data for each shape and computes the composite data for the composite shape.

**4.5 Subroutine PL4020.** This subroutine plots the composite data as a function of aspect angle.

**4.6 Subroutine OUTPR(6).** This subroutine writes composite data on Unit 6 for listing.

**4.7 Subroutine OUTPR(8).** This subroutine writes composite data on the magnetic tape on Unit 8.

**4.8 Subroutine ZEROS.** This subroutine places zeros (0.) in a large number of storage locations.

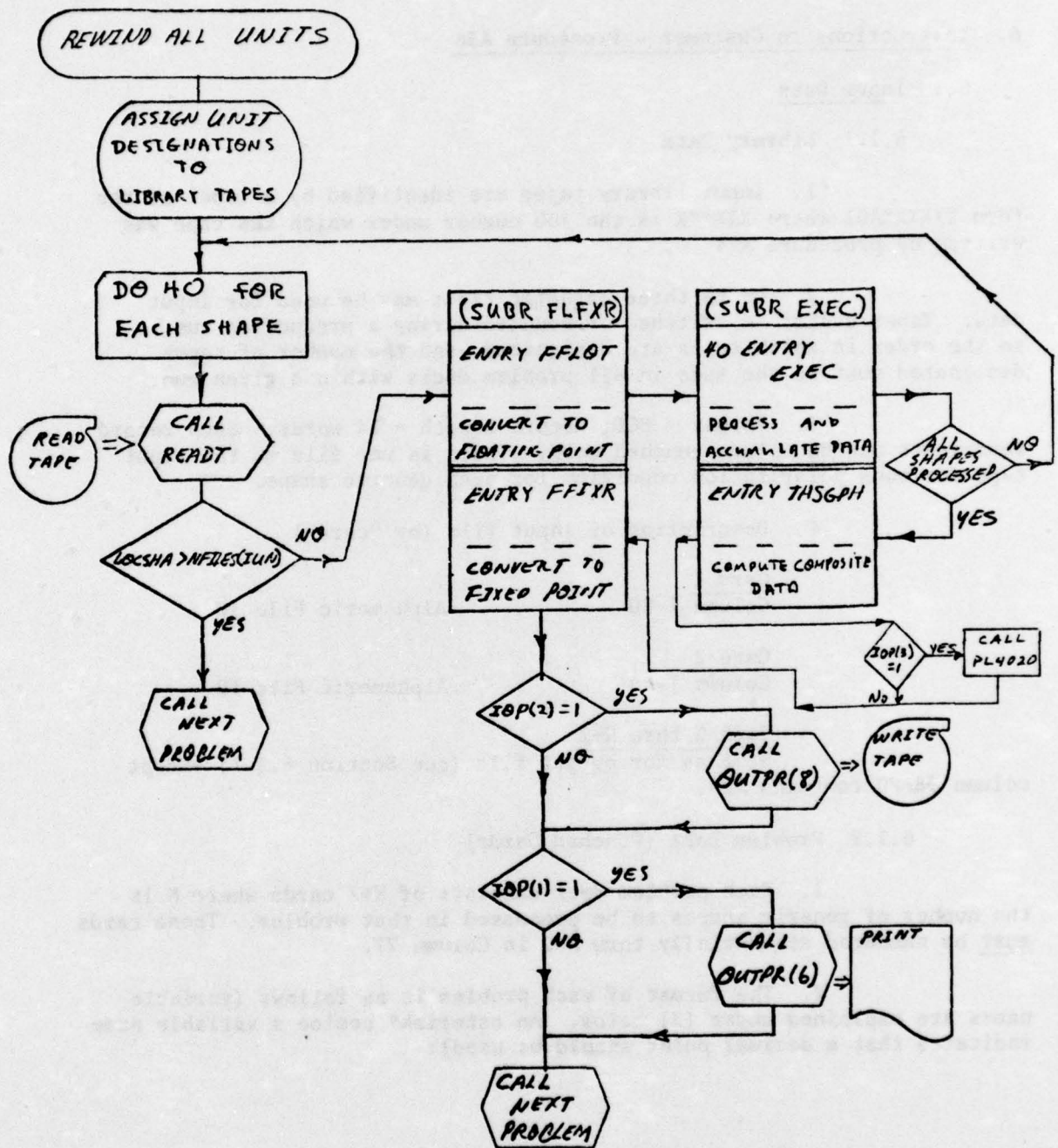

FIGURE 1. A36 LOGIC DIAGRAM

## 6. Instructions to Customer - Procedure A36

### 6.1 Input Data

#### 6.1.1 Library Data

1. Input library tapes are identified by a label of the form XXXXXA01 where XXXXX is the job number under which the tape was written by procedure A24.

2. Up to three magnetic tapes may be used for input data. Tapes cannot be switched or mounted during a production run, so the order in which tapes are designated, and the number of tapes designated must be the same in all problem decks within a given run.

3. Format - BCD; Record Length = 14 words. Each record represents one 80 column punched card. There is one file on the input tape for each polarization condition for each generic shape.

#### 4. Description of input file (by "card")

##### Card 1

Column 1-80

Alphameric File ID

##### Card 2

Column 1-80

Alphameric File ID

##### Card 3 thru N+2

Same as for output file (see Section 6.2.1) except column 78-80 contains A24.

#### 6.1.2 Problem Data (Punched Cards)

1. Each problem deck consists of N+2 cards where N is the number of generic shapes to be processed in that problem. These cards must be numbered sequentially thru N+2 in Column 77.

2. The format of each problem is as follows (variable names are explained under (3) below. An asterisk\* beside a variable name indicates that a decimal point should be used):

Card 1

Col 1-30	COMTRG
Col 31-33	NSHAPS
Col 34-37	NPTS
Col 38-40	IPITCH
Col 41-43	IROLL
Col 44	IPOL(1)
Col 45	IPOL(2)
Col 46-51	FREQ *
Col 52-55	IDLTH
Col 56-60	ITHTAO
Col 61-62	NTAPES

Card 2

Col 1-6	IFILID(1)
Col 7-9	NFILES(1)
Col 10	BLANK
Col 11-16	IFILID(2)
Col 17-19	NFILES(2)
Col 20	BLANK
Col 21-26	IFILID(3)
Col 27-29	NFILES(3)
Col 30-32	BLANK
Col 33	IOP(1)

Col 34	IOP (2)
Col 35	IOP (3)
Col 36	IOPI (1)
Col 37	IOPI (2)
Col 38-43	ISGMIN
Col 44-49	ISGMAX
Col 50-62	BLANK

Cards 3 through NSHAPS + 2 (One card per generic shape)

Col 1	IUN
Col 2-4	LOCSHA
Col 5-8	+ AZSFT
Col 9	NSHADS
Col 10-13	ISHADW (1,1)
Col 14-17	ISHADW (2,1)
Col 18-21	ISHADW (1,2)
Col 22-25	ISHADW (2,2)
Col 26-29	ISHADW (1,3)
Col 30-33	ISHADW (2,3)
Col 34-37	ISHADW (1,4)
Col 38-41	ISHADW (2,4)
Col 42-47	RHO
Col 48-53	DEE
Col 56-60	BLANK

All Cards

Col 63-68	Job Number (supplied by Operation group)
Col 69	P
Col 70-72	Problem deck number
Col 78-80	A36

All data beside which no \* appears must be right adjusted in the specified columns (except COMTRG, which is any combination of 30 alphabetic and numeric-characters) without decimal point.

3. Input Variables

<u>UNITS</u>	<u>NAME</u>	<u>USE</u>
--	COMTRG	30 Character composite target id
--	NSHAPS	Number of generic shapes for problem
--	NPTS	Number of points to be processed
Deg	IPITCH	Pitch Angle
Deg	IROLL	Roll Angle
--	IPOL(1)	Transmitter polarization (H or V)
--	IPOL(2)	Receiver polarization (H or V)
GHz	FREQ	Frequency
Deg	IDLTH	Azimuth increment for processing (X10)
Deg	ITHTAD	Initial azimuth for processing (X10)
--	NTAPES	No. of input tapes used
--	IFILID(N)	Col. 63-68 of Nth input tape (File Tape ID)

<u>UNITS</u>	<u>NAME</u>	<u>USE</u>
--	NFILES(N)	No. of files on Nth input tape
--	IOP(2)	1, write tape; 0, do not write tape
--	IOP(1)	1, print; 0, do not print
--	IOP(3)	1,plots desired; 0, no plots desired
--	IOPI(1)	1, plot amplitude; 0, do not plot amplitude
--	IOPI(2)	1, plot phase; 0, do not plot phase
Db	ISIGMIN	MINIMUM ampl. for plots (x10)
Db	ISIGMAX	MAXIMUM ampl. for plots (x10)
--	IUN	Input tape for shape (1,2,or 3)
--	LOCSHA	File (of input tape) which contains shape
--	IAZSFT	Processing will start at IAZSFTth azimuth
--	NSHADS	Number of shadow regions for shape (0,1,2,3,04 4)
--	ISHDW(1,J)	<u>Subscript</u> of start azimuth of Jth SHADOW
--	ISHADW(2,J)	<u>Subscript</u> of end azimuth of Jth SHADOW
	RHO	Aspect Angle used for positioning generic shape
inches	DEE	Radius arm length associated with RHO in positioning generic shape
Degrees	IPHI2	

## 6.2 Output Data

### 6.2.1 Magnetic Tape

1. Format - BCD; Record length - 14 words. Each record represents one 80 column punched card. There is one file on the output tape for each composite shape.

#### 2. Description of output file (by "card").

##### Card 1

Column 1-80                      Alphameric File ID

##### Card 2

Column 1-80                      Alphameric File ID

Cards 3 thru N+2                (where N= NPTS/4 +J; J=) if  
NPTS=0 mod 4, J=1 otherwise)

Column 1                          Blank

Column 2-6                        1st azimuth value (degrees X10)

Column 7-10                       1st ampl. values (dBsm X10)

Column 11-14                      1st phase values (degrees)

Column 15-28                      Repeat 1-14 for 2nd values

Column 29-42                      Repeat 1-14 for 3rd values

Column 43-56                      Repeat 1-14 for 4th values

Column 57-62                      Blank

Column 63-68                      Six digit tape number

Column 69                         "p"

Column 70-72                      Three digit file number

Column 73-77                      Five digit card number

Column 78-80                      A36

### 6.2.2 Printed Output

The printed output of Procedure A36 consists of a listing which is identical in format to the output tape described in 6.2.1. Each printed line represents one tape record "card".

```

COMMON/P/ NSHAPS, LOCSHA, IFILE(12), IAZSPT, NPT, IUN, NFILES(12),
1      NPTS, IDLTH, NSHADS, ISHADW(2,4), PHO, DEE, IOP(2),
2      IOP(3), COMTRG(5), IBSFLE, IPITCH, IROLL, IPOL(2),
3      FREQ, SQSGRE, SQSGIM, PH, ICOUNT, IDATA(3610,4),
4      IFDES(3), IPHIZ ,IEOF(12)

```

```

DIMENSION CRESIG(3610), CIMSIG(361 ), SIG(361 ), PHI(3610),
1      THET(3610), AMSIG(3610), AMPHI(3610) ,
2      CARD(10),XPAR(8),YPAR(8), X1(2), Y1(2)

```

```

EQUIVALENCE ( CRESIG(1), IDATA(1,3)),
1      ( CIMSIG(1), IDATA(1,4)),
2      ( THET(1), IDATA(1,1)),
3      ( SIG(1), IDATA(1,2)),
4      ( PHI(1), IDATA(1,3)),
5      ( AMSIG(1), IDATA(1,1)),
6      ( AMPHI(1), IDATA(1,2))

```

```

COMMON /BLOCK1/ THETA0,IDLTI
COMMON /BLOCK2/ SIGMIN,SIGMAX
COMMON /BLOCK3/ IFILID(3), NRUN

```

```

5 NRUN = 0
PRINT 2222
2222 FORMAT (53H AT COMPLETION, SAVE TAPE ON UNIT 08 AS PER JOB SHEET)

```

```
REWIND 08
```

```

10 REWIND 12
IFILE(12) = 1
REWIND 10
IFILE(10) = 1
REWIND 11
IFILE(11) = 1
20 CALL ZEROS
NRUN = NRUN + 1
READ (5,1005) COMTRG,NSHAPS,NPTS,IPITCH,IROLL,IPOL,FREQ,
1      IDLTH,ITHTAO,NTAPES, (IFILID(J),NFILES(J),J=1,3),
2      IDLTI, IOP, IOP1, ISGMIN, ISGMAX, IBSFLE
C      COMTRG --- 30 CHARACTER COMPOSITE TARGET ID
C      NSHAPS --- NUMBER OF GENERIC SHAPES TO BE PROCESSED
C      NPTS --- NUMBER OF POINTS TO BE READ FROM TAPE(S)
C      IPITCH --- PITCH ANGLE
C      IROLL --- ROLL ANGLE
C      IPOL(1) --- TRANSMITTER POLARIZATION (H OR V)
C      IPOL(2) --- RECEIVER POLARIZATION (H OR V)
C      FREQ --- FREQUENCY (GHZ)

```

```

C      IDLTH --- AZIMUTH INCREMENT FOR PROCESSING
C      ITHTAO --- INITIAL AZIMUTH FOR PROCESSING
C      NTAPES --- NUMBER OF INPUT TAPES (1, 2, OR 3)
C      IFILID(J) --- COL. 63-68 OF JTH INPUT TAPE
C      NFILES(J) --- NUMBER OF FILES ON JTH INPUT TAPE
C      IOP(1) --- 1, PRINT      0, NO PRINT
C      IOP(2) --- 1, TAPE      0, NO TAPE
C      IOP(3) --- 1, PLOTS     0, NO PLOTS
C      IOI(1) --- 1, PLOT SIGMA 0, DO NOT PLOT SIGMA
C      IOI(2) --- 1, PLOT PHASE 0, DO NOT PLOT PHASE
C      ISGMIN --- MINIMUM SIGMA VALUE FOR PLOT
C      ISGMAX --- MAXIMUM SIGMA VALUE FOR PLOT
C      IBSPLE --- PLOTTING INCREMENT
C
C***** IF (NRUN .NE. 1) GO TO 15
C***** CHECK UNIT SETUPS **
      LIM = 9 + NTAPES
      DO 13 IUNIT = 10, LIM
        READ (IUNIT, 1001) (CARD(I), I=1, 10)
        READ (IUNIT, 1000) (CARD(I), I=1, 6)
        READ (IUNIT, 1000) IFILEI
        DO 11 I = 1, NTAPES
          11 IF (IFILID(I) .EQ. IFILEI) GO TO 12
          GO TO 14
          12 IFDES(I) = IUNIT
          WRITE (6, 3006) IFDES(I)
          3 06 FORMAT ( I7)
          NFILES(IUNIT) = NFILES(I)
          13 REWIND IUNIT
          GO TO 15
          14 WRITE (6, 2000) IFILEI, IUNIT
          CALL EXIT
C***** UNITS ASSIGNED--EXECUTE PROBLEM **
      15 IF (IDLTH .LE. 0) IDLTH = 1
          IDLTI = IDLTH
          THETA = FLOAT(ITHTAO) / 10.0
          SIGMIN = FLOAT(ISGMIN) / 10.0
          SIGMAX = FLOAT(ISGMAX) / 10.0
          DO 40 NSHAPE = 1, NSHAPS
            READ (5, 2005) IUN, LOCSHA, IAZSPT, NSHADS, ((ISHADW(I, J), I=1, 2), J=1, 4)
            1, RHO, DEE, IPHIZ
            IF (IAZSPT .LE. 0) IAZSPT = 1
            IUN = IFDES(IUN)
C***** SUBROUTINE READT READS DATA FOR GENERIC SHAPE **
            CALL READT(KERROR)
            GO TO (1, 2) , KERROR
C***** ENTRY PFLOT(SUBR PLFXR) CONVERTS DATA TO FLOATING PT.**
            1 CALL PFLOT
C***** SUBROUTINE EXEC PROCESSES AND ACCUMULATES DATA FOR EACH SHAPE **
            40 CALL EXEC
C***** ENTRY THSGPH(SUBR EXEC) CALCULATES COMPOSITE OF GENERIC SHAPES **

```

```

      CALL THSGPH
C**** SUBROUTINE PL4020 PLOTS COMPOSITE DATA ON RADC PLOTTER
      IF(IOP(3).EQ. 1) CALL PL4020
C**** ENTRY FFIXR(SUBR FLFXR) CONVERTS COMPOSITE DATA TO INTEGER **
      CALL FFIXR
C**** SUBROUTINE OUTPR(J) WRITES COMPOSITE DATA ON UNIT J **
      IF (IOP(2) .EQ. 1) CALL OUTPR(8)
      IF (IOP(1) .EQ. 1) CALL OUTPR(6)
C**** PROBLEM COMPLETE AT THIS POINT **
      GO TO 20
C   2--FILE REQUESTED GREATER THAN NO.OF FILES ON TAPE.
      2 WRITE (6,1006)  LOCSHA, NFILES(IUN), IUN
      GO TO 10

C*****FORMAT STATEMENTS*****
1 00 FORMAT (62X, I6)
1 01 FORMAT(10A6)
1 05 FORMAT(5A6,I3,I4,2I3,2A1,F6.3,I4,I5,I2/3(I6,I3,1X),I2,5I1,3I6)
2 05 FORMAT ( I1,I3,I4, I1,8I4,F6.3,F6.3,2X,I5)
1 06 FORMAT ( I3, 6H REQ.,, I3, 14H FILES ON TAPE, I2)
2 00 FORMAT (6H FILE ,I5,10H ON UNIT ,I2,12H NOT REQ D.)
C*****
1003 FORMAT(10X,27HINPUT ERROR ON FIRST RECORD)
1 04 FORMAT(10X,28HINPUT ERROR ON SECOND RECORD)
1 07 FORMAT(10X,33HINPUT ERROR ON SUCCEEDING RECORDS)
      END

```

SUBROUTINE READT(KERROR)

COMMON/P/ NSHAPS, LOCSHA, IFILE(12), IAZSPT, NPT, IUN, NFILES(12),  
1 NPTS, IDLTH, NSHADS, ISHADW(2,4), RHO, DEE, IOP(2),  
2 IOP(3), COMTRG(5), IBSFLE, IPITCH, IROLL, IPOL(2),  
3 FREQ, SQSGRE, SQSGIM, PH, ICOUNT, IDATA(3610,4),  
4 IPDES(3), IPHIZ, IEOF(12)  
COMMON /FLAG / ITEM

DIMENSION CARD (10)  
DIMENSION CRESIG(3610), CIMSIG(3610), SIG(3610), PHI(3610),  
1 THET(3610), AMSIG(3610), AMPHI(3610)

EQUIVALENCE ( CRESIG(1), IDATA(1,3)),  
1 ( CIMSIG(1), IDATA(1,4)),  
2 ( THET(1), IDATA(1,1)),  
3 ( SIG(1), IDATA(1,2)),  
4 ( PHI(1), IDATA(1,3)),  
5 ( AMSIG(1), IDATA(1,1)),  
6 ( AMPHI(1), IDATA(1,2))

KERROR = 1

IF (LOCSHA .GT. NFILES(IUN)) GO TO 50  
10 CALL FLGEOF(IUN,IEOF(IUN))  
IF (LOCSHA .NE. IFILE (IUN)) GO TO 30  
READ (IUN,1008) (CARD(I),I=1,10)  
READ (IUN,1008) (CARD(I),I=1,6)  
READ(IUN,2008) (( IDATA(NPT,NVAR),NVAR=1,2),NPT=1,NPTS)  
20 READ(IUN,1009) BLANK  
IF (IEOF(IUN) .GT. 0) GO TO 60  
GO TO 20  
30 IF (LOCSHA .GT. IFILE (IUN)) GO TO 40  
REWIND IUN  
IFILE(IUN) = 1  
GO TO 10  
40 DO 41 NCARD = 1,900  
READ(IUN,1009) BLANK  
41 CONTINUE  
42 READ(IUN,1009) BLANK  
IF(IEOF(IUN) .LE. 0) GO TO 42  
IEOF(IUN) = 0  
IFILE(IUN) = IFILE(IUN) + 1  
GO TO 10

```
50 KERROR = 2  
RETURN
```

```
60 IFILE(IUN) = IFILE(IUN) + 1  
IEOF(IUN) = 0  
RETURN
```

```
C**** FORMAT STATEMENTS ****  
1 08 FORMAT(10A6)  
1 09 FORMAT(A6)  
2 08 FORMAT ( 4( 6X,2I4))  
C*****
```

```
END
```

```

1          SUBROUTINE FLPXR
FIRST DELIMITER OF SUBROUTINE STATEMENT IS ILLEGAL
2
3          1      NPTS, IDLTH, NSHADS, ISHADW(2,4), RHO, DEE, IOP1(2),
4          2      IOP(3), COMTRG(5), IBSFLE, IPITCH, IROLL, IPOL(2),
5          3      FREQ, SQSGRE, SQSGIM, PH, ICOUNT, IDATA(3610,4),
6          4      IPDES(3), IPHI2, IEOF(12)
7
8          DIMENSION CRESIG(3610), CIMSIG(3610), SIG(3610), PHI(3610),
9          1      THET(3610), AMSIG(3610), AMPHI(3610)
10
11
12         EQUIVALENCE ( CRESIG(1), IDATA(1,3)),
13         1      ( CIMSIG(1), IDATA(1,4)),
14         2      ( THET(1), IDATA(1,1)),
15         3      ( SIG(1), IDATA(1,2)),
16         4      ( PHI(1), IDATA(1,3)),
17         5      ( AMSIG(1), IDATA(1,1)),
18         6      ( AMPHI(1), IDATA(1,2))
19
20
21
22         ENTRY FFLOT
FUNCTION ENTRY MUST HAVE AN ARGUMENT LIST
ENTRY STATEMENT IS ILLEGAL IN MAIN
23         DO 10 NPT = 1, NPTS
24         AMSIG(NPT) = FLOAT(IDATA(NPT,1)) / 10.0
IDATA IS AN UNDIMENSIONED ARRAY OR AN INVALID FUNCTION
25         10 AMPHI(NPT) = IDATA(NPT,2)
IDATA IS AN UNDIMENSIONED ARRAY OR AN INVALID FUNCTION
26         RETURN
RETURN STATEMENT IS ILLEGAL IN MAIN
27         ENTRY FFI XR
FUNCTION ENTRY MUST HAVE AN ARGUMENT LIST
ENTRY STATEMENT IS ILLEGAL IN MAIN
28         DO 20 NPT = 1, ICOUNT
29         RND = 0.5
30         IF ( THET(NPT) .LT. 0.) RND = -0.5
31         IDATA(NPT,1) = THET(NPT) * 10.0 + RND
IDATA IS AN UNDIMENSIONED ARRAY OR A MISPLACED ASF
32         RND = 0.5
33         IF ( SIG(NPT) .LT. 0.) RND = -0.5
34         IDATA(NPT,2) = SIG(NPT) * 10.0 + RND
IDATA IS AN UNDIMENSIONED ARRAY OR A MISPLACED ASF
35         20 IDATA(NPT,3) = PHI(NPT) + 0.5
IDATA IS AN UNDIMENSIONED ARRAY OR A MISPLACED ASF
36         RETURN
RETURN STATEMENT IS ILLEGAL IN MAIN
37         END
'STOP' STATEMENT IS MISSING-SIMULATED
IDATA IS USED AS AN ARRAY IN AN EQUIVALENCE STATEMENT BUT IS NOT DIMENSIONED
IDATA IS USED AS AN ARRAY IN AN EQUIVALENCE STATEMENT BUT IS NOT DIMENSIONED

```

IDATA IS USED AS AN ARRAY IN AN EQUIVALENCE STATEMENT BUT IS NOT DIMENSIONED  
IDATA IS USED AS AN ARRAY IN AN EQUIVALENCE STATEMENT BUT IS NOT DIMENSIONED  
IDATA IS USED AS AN ARRAY IN AN EQUIVALENCE STATEMENT BUT IS NOT DIMENSIONED  
IDATA IS USED AS AN ARRAY IN AN EQUIVALENCE STATEMENT BUT IS NOT DIMENSIONED  
IDATA IS USED AS AN ARRAY IN AN EQUIVALENCE STATEMENT BUT IS NOT DIMENSIONED

SUBROUTINE EXEC

```

COMMON/P/ NSHAPS, LOCSHA, IFILE(12), IAZSFT, NPT, YUN, NFILES(12),
1  NPTS, IDLTH, NSHADS, ISHADW(2,4), RHO, DEE, IOP(2),
2  IOP(3), COMTRG(5), IBSFLE, IPITCH, IROLL, IPOL(2),
3  FREQ, SQSGRE, SQSGIM, PH, ICOUNT, IDATA(3610,4),
4  IPDES(3), IPHIZ, IEOF(12)

```

```

DIMENSION CRESIG(3610), CIMSIG(3610), SIG(3610), PHI(3610),
1  THET(3610), AMSIG(3610), AMPHI(3610)

```

```

EQUIVALENCE ( CRESIG(1), IDATA(1,3)),
1  ( CIMSIG(1), IDATA(1,4)),
2  ( THET(1), IDATA(1,1)),
3  ( SIG(1), IDATA(1,2)),
4  ( PHI(1), IDATA(1,3)),
5  ( AMSIG(1), IDATA(1,1)),
6  ( AMPHI(1), IDATA(1,2))

```

```

COMMON /BLOCK1/ THETA0, NTH
DATA PI180 / .174532925E-1/
DLTHT = FLOAT(IDLTH) / 10.0
COEFF = DEE * 720, * FREQ / 11.81
N1 = NPTS
I1 = IAZSFT
ICOUNT = 0
5 DO 20 NPT = I1, N1, NTH
  ICOUNT = ICOUNT + 1

  IF ( NSHADS .LE. 0) GO TO 11
  DO 10 K=1, NSHADS
10 IF (NPT .GE. ISHADW(1,K) .AND.
1  NPT .LE. ISHADW(2,K) ) GO TO 20
11 ARG = PI180 * (RHO - DLTHT*FLOAT(ICOUNT-1))
  PHIZ = IPHIZ
  PHIZ = PHIZ / 10.0
  PH = AMOD (AMPHI(NPT)+PHIZ + COEFF*COS(ARG), 36.)
  SQSG = 10.0 ** (AMSIG(NPT) / 20.0)
  ARG = PI180 * PH
  SQSGIM = SIN(ARG) * SQSG
  SQSGRE = COS(ARG) * SQSG
  CIMSIG(ICOUNT) = CIMSIG(ICOUNT) + SQSGIM
  CRESIG(ICOUNT) = CRESIG(ICOUNT) + SQSGRE
20 CONTINUE
  IF (I1 .EQ. 1) RETURN
  I1 = I1 + 1
  N1 = IAZSFT
  GO TO 5

```

ENTRY THSGPH

```
DO 30 NPT = 1,ICOUNT
  THET(NPT) = DLHT * FLOAT(NPT-1) + THETA0
    A1 = CIMSIG(NPT)
    A2 = CRESIG(NPT)
    ARG = A1/A2
  ARG1 = A1*A1 + A2*A2
  IF( ARG1 .LE. .000001) GO TO 301
  SIG(NPT) = 10.0 * ALOG10(ARG1)
  GO TO 35
301 SIG(NPT) = -80.
35 IF(ARG) 40,50,60

40 IF (A1 ) 50,50,70
60 IF (A1 ) 70,50,50
70 ADJ = 180.0
  GO TO 80
50 ADJ = 0.0
80 PHASE = ATAN(ARG) / PI180 + ADJ
  IF (PHASE .LE. 0.) PHASE = PHASE + 360.0
30 PHI(NPT) = PHASE
  RETURN
END
```

SUBROUTINE OUTPR (K)

```
COMMON/P/ NSHAPS, LOCSHA, IFILE(12), IAZSPT, NPT, IUN, NFILES(12),
1 NPTS, IDLTH, NSHADS, ISHADW(2,4), RHO, DEE, IOP1(2),
2 IOP(3), COMTRG(5), IBSFLE, IPITCH, IROLL, IPOL(2),
3 FREQ, SQSGRE, SQSGIM, PH, ICOUNT, IDATA(3610,4),
4 IFDES(3), IPHIZ, IEOF(12)
```

```
DIMENSION CRESIG(3610), CIMSIG(3610), SIG(3610), PHI(3610),
1 THET(3610), AMSIG(3610), AMPHI(3610)
```

```
EQUIVALENCE ( CRESIG(1), IDATA(1,3)),
1 ( CIMSIG(1), IDATA(1,4)),
2 ( THET(1), IDATA(1,1)),
3 ( SIG(1), IDATA(1,2)),
4 ( PHI(1), IDATA(1,3)),
5 ( AMSIG(1), IDATA(1,1)),
6 ( AMPHI(1), IDATA(1,2))
```

```
COMMON /BLOCKS/ ID1, DUMMY(2), ID2
```

```
DIMENSION IDOU(3)
```

```
IUN = K
IDOU(1) = ID1 + 1000000
IDOU(2) = ID2 + 1000000
IDOU(3) = 1000001
```

```
WRITE (IUN,5000) COMTRG, IROLL, IPITCH, IPOL, FREQ
```

```
NPT = 0
5 NPT = NPT + 4
NSTART = NPT - 3
INDX = ICOUNT - NSTART + 1
IF (INDX .LT. 4 .AND. INDX .GT. 0) GO TO(2,30,4), INDX
IF (INDX .EQ. 0) GO TO 50
10 WRITE(IUN,1000) ((IDATA(I,J), J=1,3), I=NSTART, NPT), IDOU
IDOU(3) = IDOU(3) + 1
```

```
GO TO 5
```

```
20 WRITE(IUM,2000) ((IDATA(I,J),J=1,3),I=NSTART,NPTS), IDOU  
GO TO 50
```

```
30 WRITE(IUM,3000) ((IDATA(I,J),J=1,3),I=NSTART,NPTS), IDOU  
GO TO 50
```

```
40 WRITE(IUM,4000) ((IDATA(I,J),J=1,3),I=NSTART,NPTS), IDOU  
50 IF (IUM .EQ. 8) ENDFILE 8
```

```
RETURN
```

```
C*****FORMAT STATEMENTS*****
```

```
1 00 FORMAT ( 4(1X,I5,I4,I4), 6X, I6,1HP,I3,I5,3HA36)
```

```
2 00 FORMAT ( 1(1X,I5,I4,I4),48X, I6,1HP,I3,I5,3HA36)
```

```
3 00 FORMAT ( 2(1X,I5,I4,I4),34X, I6,1HP,I3,I5,3HA36)
```

```
4 00 FORMAT ( 3(1X,I5,I4,I4),20X, I6,1HP,I3,I5,3HA36)
```

```
5 00 FORMAT ( 1H ,5A6,2HRA,I3,2HRA,I3,4H P T,A1,2H R,A1,4H F ,F6.3,
```

```
13HGHZ,18H
```

```
2
```

```
19H FORMAT(AZ,SIG,PHA).
```

```
3 61H
```

```
END
```

SUBROUTINE ZEROS

COMMON/P/ FILLER(7280), ZERO(7220)

DO 10 I=1,7220

10 ZERO(I) = 0.0

RETURN

END

SUBROUTINE PL4020

COMMON/P/ NSHAPS, LOCSHA, IFILE(12), IAZSFT, NPT, IUN, NFILES(12),

1 NPTS, IDLTH, NSHADS, ISHADW(2,4), RHO, DEE, IOP(2),

2 IOP(3), COMTRG(5), IBSFLE, IPITCH, IROLL, IPOL(2),

3 FREQ, SOSGRE, SOSGIM, PH, ICOUNT, IDATA(3610,4),

4 YFDES(3), IPHIZ, IEOF(12)

COMMON /BLOCK2/ SIGMIN, SIGMAX

DIMENSION CRESIG(3610), CIMSIG(3610), SIG(3610), PHI(3610),

1 THET(3610), AMSIG(3610), AMPHI(3610), A(3610), Y(3610,2),

2 ISTART(2), IEND(2), IHEAD(8), AZMIN(2), AZMAX(2),

3 CARD(10), XPAR(8), YPAR(8), X1(2), Y1(2)

EQUIVALENCE ( CRESIG(1), IDATA(1,3)),

1 ( CIMSIG(1), IDATA(1,4)),

2 ( THET(1), IDATA(1,1)),

3 ( SIG(1), IDATA(1,2)),

4 ( PHI(1), IDATA(1,3)),

5 ( AMSIG(1), IDATA(1,1)),

6 ( AMPHI(1), IDATA(1,2)),

7 ( A(1), IDATA(1,1)),

8 ( Y(1,1), IDATA(1,2))

C\*\*\*\* XPAR AND YPAR ARRAY PARAMETERS ARE DEFINED AS FOLLOWS

C\*\*\* XPAR(1) = X CORNER YPAR(1) = Y CORNER

C\*\*\* XPAR(2) = X SIZE OF PAPER YPAR(2) = Y SIZE OF PAPER

C\*\*\* XPAR(3) = X ORIGIN YPAR(3) = Y ORIGIN

C\*\*W XPAR(4) = X SCALE YPAR(4) = Y SCALE

C\*\*W XPAR(5) = PRINT MODE SELECT YPAR(5) = PRINTER SYMBOL SELECT

C\*\*W XPAR(6) = X ERROR COUNT YPAR(6) = Y ERROR COUNT

C\*\*\* XPAR(7) = X START YPAR(7) = Y START

C\*\*\* XPAR(8) = X INCREMENT YPAR(8) = Y INCREMENT

C

C\*\*\* PLOT SUBROUTINES ARE DEFINED AS FOLLOWS

C

C\*\*\* CALL GRID(XINC, YINC, XPAR, YPAR, IND) USES XPAR AND YPAR 1,2

C\*\*\* CALL LINE(XAR, YAR, IOUNT, XPAR, YPAR) USES XPAR AND YPAR 1,2,3,4,6

C\*\*\* CALL POINT(XAR, YAR, IOUNT, XPAR, YPAR) USES XPAR AND YPAR 1,2,3,4,5,6

C\*\*\* CALL NUMBER(VALUE, NDEC, XPAR, YPAR) USES XPAR 1,2,6,7,8 AND YPAR 1,2,7

C\*\*\* CALL PRINT(TEXT, COUNT, XPAR, YPAR) USES XPAR 1,2,6,7,8 AND YPAR 1,2,7

C\*\*\* CALL RANGE(ARRAY, INITIAL, LAST, RMAX, RMIN)

C\*\*W XPAR(CORNER, PAPER SIZE, ORIGIN, SCALE, PRINT MODE, ERROR, START, IN

C\*\*W YPAR(CORNER, PAPER SIZE, ORIGIN, SCALE, SYMBOL, ERROR, START, IN

C\*\*\* XPAR( 1, 2, 3, 4, 5, 6, 7, 8 )  
DATA XPAR/0.0,25.0,15.0,20.0,17.0,0.0,5.8,1.1/

C

C\*\*\* YPAR( 1, 2, 3, 4, 5, 6, 7, 8 )  
DATA YPAR/0.0,25.0,12.0,5.0,12.0,0.0,1.5,0.0/

IOUNT =3600/IPSFLE

```

5 IF(IOP1(1) .NE. 1) GO TO 105
IF(IBSFLE .LE. 0) IBSFLE = 1
999 FORMAT(1X,16F4.1)
WRITE(6,999)((XPAR(KK),KK=1,8),(YPAR(LL),LL=1,8))
10 CALL GRID(1.0,1.0,XPAR,YPAR,1)
WRITE(6,999)((XPAR(KK),KK=1,8),(YPAR(LL),LL=1,8))
CALL NUMBER(-180.0,1,XPAR,YPAR)
XPAR(7) = 14.8
15 CALL NUMBER(0.0,1,XPAR,YPAR)
XPAR(7) = 23.8
CALL NUMBER(180.0,1,XPAR,YPAR)
XPAR(7) = 5.0
YPAR(7) = 2.0
YB = SIGMIN
YT = SIGMAX
20 CALL NUMBER(YB,1,XPAR,YPAR)
YPAR(7) = 12.0
CALL NUMBER(YT,1,XPAR,YPAR)
YPAR(3) = 12.0 - YT
WRITE(6,999)((XPAR(KK),KK=1,8),(YPAR(LL),LL=1,8))
888 FORMAT(1X,2F12.6)
WRITE(6,888) A(1),Y(1,1)
25 DO 60 NPT = 1,3600,IBSFLE
NPT1 = NPT + IBSFLE
X1(1) = A(NPT)
X1(2) = A(NPT1)
Y1(1) = Y(NPT,1)
Y1(2) = Y(NPT1,1)
60 CALL LINE(X1,Y1,ICOUNT,XPAR,YPAR)
105 IF(IOP1(2) .NE. 1) RETURN
DATA YPAR/0.0,25.0,14.0,20.0,12.0,0.0,13.5,0.0/
110 CALL GRID(1.0,1.0,XPAR,YPAR,1)
CALL NUMBER(-180.0,1,XPAR,YPAR)
XPAR(7) = 14.8
115 CALL NUMBER(0.0,1,XPAR,YPAR)
XPAR(7) = 23.8
CALL NUMBER(180.0,1,XPAR,YPAR)
XPAR(7) = 5.0
YPAR(7) = 14.0
120 CALL NUMBER(0.0,1,XPAR,YPAR)
YPAR(7) = 19.0
CALL NUMBER(180.0,1,XPAR,YPAR)
YPAR(7) = 24.0
CALL NUMBER(360.0,1,XPAR,YPAR)
WRITE(6,999)((XPAR(KK),KK=1,8),(YPAR(LL),LL=1,8))
125 DO 16 NPT = 1,3600,IBSFLE
NPT1 = NPT + IBSFLE
X1(1) = A(NPT)
X1(2) = A(NPT1)
Y1(1) = Y(NPT,2)
Y1(2) = Y(NPT1,2)
160 CALL LINE(X1,Y1,ICOUNT,XPAR,YPAR)

```

```

105          CALL STDBY
106          CALL STDBY
107          RETURN
108          END
NON-BLANK CHARACTERS IN COLUMNS 1-5 ILLEGAL. CHECK FORM/NFORM OPTION
FIRST WORD OF STATEMENT IS UNRECOGNIZABLE OR THE FIRST DELIMETER IS ILLEGAL
NON-BLANK CHARACTERS IN COLUMNS 1-5 ILLEGAL. CHECK FORM/NFORM OPTION
109          CHECKOUT TARGET P2Y5F3-F5CY5 23600 0 OHMS.975 1-1800 1
110          .65951 8 10100 -4 0 1000 1-1800 1
111          1 1 0119003600 0. 0.
STATEMENT LABEL MUST BE BETWEEN 1 AND 99999
. IS ILLEGAL AS THE FIRST CHARACTER OF A STATEMENT
STATEMENT IS NEVER REFERENCED
112          1 2 10011700 0. .
STATEMENT LABEL MUST BE BETWEEN 1 AND 99999
. IS ILLEGAL AS THE FIRST CHARACTER OF A STATEMENT
RETURN STATEMENT MISSING-SIMULATED
'END' STATEMENT MISSING-SIMULATED

```

## 8.0 Sample Problem

### 8.1 Description

The enclosed sample problem identified by job number 064052-001 superimposes measured signature data for generic Models F5 and Cy5. Model F5 data is contained on file number 2 of A24 library tape 964216A01 and Model Cy5 data is contained on file number 3 of the same tape. There are 3600 data points per shape and pitch and roll angles are both zero degrees. The library data was obtained using horizontally polarized transmitter and receiver antennas at a frequency of 5.885 GHz. The values of the radius arm angle (RHO) and the radius arm length (DEE) necessary to obtain the composite shape are given in the input data. The value of IPHIZ required to correct the phase of each generic shape is also given in the input data. The values of RHO, DEE, and IPHIZ are obtained from the location geometry and measured phase data for each generic shape.

DEE and RHO are the polar coordinates required to synthesize the location of each shape in its respective position as a component of the composite shape. For example, if Frustrum F5 were aligned as shown in Figure 1a when originally measured, values of DEE = 8.2 inches and RHO = 7.6 degrees would be required to shift the reference point (in this case, the center of the large face of the frustrum) so that the composite Model F5CY5 could be formed as shown in Figure 1b.

Subroutine EXEC utilizes the values of RHO, DEE, IPHIZ, and measured phase to compute the value of phase which would be measured if the shape were actually located in the new position. The angle RHO is necessary to account for errors in alignment of the generic shape with respect to the center of rotation of the turntable.

### 8.2 Input Data

The attached Digital Computer Data Sheet gives the input data for this sample problem. Columns 33-55 of card #2 are used to provide instructions for the SC4020 plotter at GD/FW and may be ignored.

### 8.3 Output Data

The attached output listing gives the output data obtained using the data in Section 8.2 and the measured data obtained from files number 2 and 3 of the the library tape.

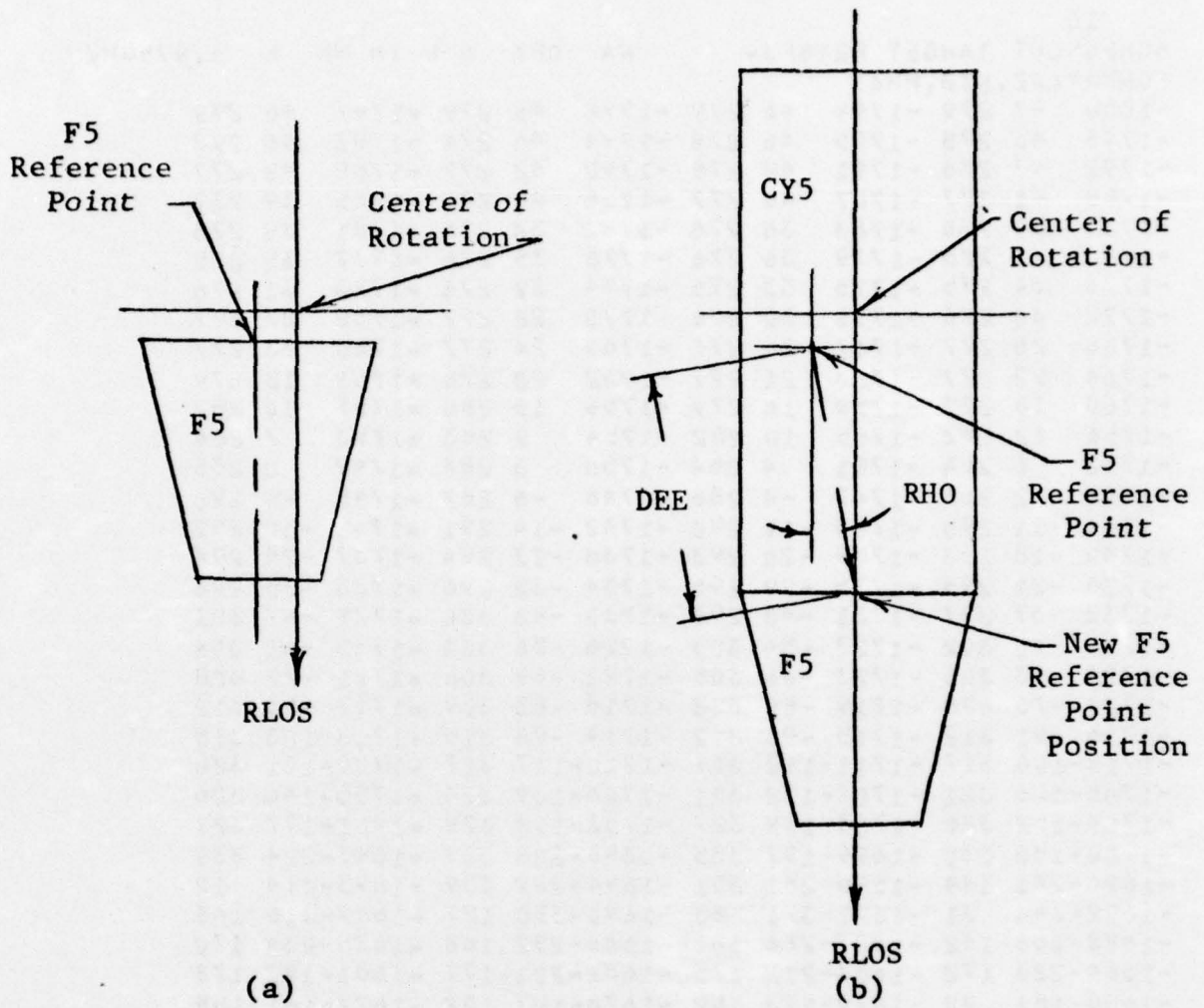

Fig. 1. RELATIONSHIP OF RHO AND DEE TO VEHICLE REFERENCE POINT LOCATION

10

6CHECKOUT TARGET F2Y5F3- RA OPA O P TH RH F 5.975GHZ  
 FORMAT(AZ, SIG, PHA)

-1800	47	279	-1799	46	279	-1798	46	279	-1797	46	279
-1796	46	278	-1795	46	278	-1794	46	278	-1793	46	278
-1792	43	278	-1791	42	278	-1790	42	277	-1789	42	277
-1788	41	277	-1787	40	277	-1786	40	277	-1785	39	277
-1784	39	276	-1783	38	276	-1782	38	276	-1781	38	276
-1780	37	276	-1779	36	276	-1778	35	276	-1777	35	275
-1776	34	275	-1775	33	275	-1774	32	276	-1773	31	276
-1772	30	276	-1771	30	276	-1770	28	277	-1769	27	277
-1768	26	277	-1767	26	277	-1766	24	277	-1765	23	277
-1764	22	277	-1763	21	277	-1762	20	276	-1761	18	279
-1760	18	279	-1759	16	279	-1758	15	280	-1757	13	282
-1756	12	282	-1755	10	282	-1754	9	283	-1753	7	284
-1752	6	284	-1751	4	284	-1750	3	284	-1749	0	285
-1748	-2	286	-1747	-4	286	-1746	-6	287	-1745	-8	290
-1744	-11	290	-1743	-12	290	-1742	-14	291	-1741	-16	292
-1740	-18	293	-1739	-20	293	-1738	-23	294	-1737	-24	294
-1736	-26	295	-1735	-29	296	-1734	-32	296	-1733	-35	296
-1732	-37	297	-1731	-40	298	-1730	-43	300	-1729	-47	301
-1728	-50	302	-1727	-54	303	-1726	-56	303	-1725	-60	304
-1724	-63	306	-1723	-66	306	-1722	-69	306	-1721	-72	308
-1720	-76	308	-1719	-80	308	-1718	-83	309	-1717	-86	312
-1716	-91	312	-1715	-95	312	-1714	-98	315	-1713	-103	315
-1712	-106	317	-1711	-112	317	-1710	-117	317	-1709	-121	320
-1708	-126	321	-1707	-132	321	-1706	-139	324	-1705	-146	326
-1704	-152	326	-1703	-159	327	-1702	-168	329	-1701	-177	329
-1700	-186	330	-1699	-197	335	-1698	-208	337	-1697	-224	339
-1696	-241	344	-1695	-261	351	-1694	-282	359	-1693	-314	12
-1692	-344	351	-1691	-371	363	-1690	-350	127	-1689	-316	146
-1688	-286	162	-1687	-266	168	-1686	-252	168	-1685	-234	170
-1684	-223	172	-1683	-212	175	-1682	-201	177	-1681	-192	178
-1680	-181	180	-1679	-173	182	-1678	-167	182	-1677	-161	185
-1676	-157	186	-1675	-153	187	-1674	-149	187	-1673	-146	188
-1672	-144	190	-1671	-140	190	-1670	-139	189	-1669	-136	191
-1668	-134	193	-1667	-132	193	-1666	-131	194	-1665	-129	196
-1664	-128	198	-1663	-127	199	-1662	-126	201	-1661	-125	202
-1660	-125	202	-1659	-124	203	-1658	-124	204	-1657	-124	212
-1656	-124	212	-1655	-120	212	-1654	-127	212	-1653	-127	215
-1652	-128	217	-1651	-130	219	-1650	-131	221	-1649	-132	222
-1648	-133	224	-1647	-135	226	-1646	-136	228	-1645	-137	232
-1644	-140	237	-1643	-142	239	-1642	-144	240	-1641	-147	240
-1640	-149	242	-1639	-152	246	-1638	-155	248	-1637	-158	248
-1636	-161	251	-1635	-164	255	-1634	-167	259	-1633	-172	262

-1632-174	265	-1631-170	269	-1630-181	275	-1629-185	277
-1628-186	281	-1627-193	280	-1626-195	281	-1625-197	287
-1624-201	290	-1623-204	292	-1622-206	296	-1621-209	300
-1620-211	303	-1619-213	306	-1618-215	308	-1617-216	313
-1616-217	316	-1615-217	317	-1614-216	324	-1613-218	326
-1612-216	329	-1611-219	332	-1610-220	334	-1609-222	339
-1608-224	340	-1607-223	343	-1606-230	344	-1605-233	351
-1604-237	360	-1603-242	360	-1602-247	1	-1601-252	7
-1600-261	7	-1599-270	10	-1598-281	10	-1597-292	11
-1596-307	12	-1595-323	14	-1594-337	15	-1593-362	17
-1592-393	17	-1591-400	21	-1590-400	30	-1589-400	43
-1588-395	74	-1587-358	184	-1586-333	229	-1585-311	239
-1584-298	240	-1583-288	240	-1582-274	240	-1581-266	240
-1580-257	240	-1579-250	240	-1578-245	242	-1577-238	244
-1576-235	243	-1575-231	247	-1574-227	252	-1573-225	252
-1572-224	253	-1571-222	259	-1570-222	260	-1569-218	260
-1568-217	265	-1567-216	271	-1566-217	271	-1565-216	274
-1564-216	278	-1563-217	279	-1562-217	282	-1561-215	287
-1560-214	287	-1559-214	291	-1558-212	296	-1557-211	296
-1556-209	299	-1555-208	306	-1554-207	310	-1553-204	309
-1552-202	314	-1551-199	325	-1550-197	326	-1549-194	328
-1548-192	333	-1547-190	336	-1546-189	337	-1545-186	344
-1544-185	352	-1543-183	352	-1542-183	357	-1541-182	1
-1540-181	1	-1539-182	2	-1538-181	6	-1537-182	11
-1536-184	11	-1535-186	13	-1534-186	20	-1533-189	21
-1532-192	21	-1531-194	22	-1530-197	22	-1529-201	22
-1528-206	28	-1527-212	29	-1526-216	29	-1525-223	35
-1524-229	37	-1523-237	38	-1522-244	39	-1521-255	43
-1520-262	45	-1519-274	49	-1518-284	52	-1517-300	59
-1516-313	66	-1515-327	82	-1514-334	103	-1513-338	121
-1512-333	132	-1511-325	156	-1510-315	166	-1509-308	171
-1508-295	164	-1507-291	167	-1506-281	188	-1505-280	192
-1504-273	192	-1503-270	193	-1502-267	197	-1501-272	197
-1500-274	197	-1499-276	198	-1498-278	198	-1497-284	200
-1496-290	199	-1495-299	200	-1494-308	200	-1493-322	200
-1492-332	200	-1491-352	197	-1490-367	191	-1489-377	185
-1488-376	173	-1487-361	147	-1486-340	130	-1485-313	110
-1484-300	101	-1483-285	94	-1482-271	92	-1481-259	85
-1480-250	83	-1479-241	83	-1478-236	78	-1477-230	74
-1476-225	73	-1475-220	77	-1474-218	77	-1473-216	75
-1472-213	75	-1471-212	77	-1470-212	77	-1469-212	77
-1468-211	81	-1467-217	81	-1466-217	85	-1465-220	88
-1464-222	88	-1463-224	90	-1462-229	93	-1461-232	97
-1460-233	100	-1459-237	108	-1458-240	118	-1457-243	125
-1456-243	135	-1455-242	147	-1454-239	148	-1453-233	159
-1452-229	167	-1451-224	168	-1450-219	174	-1449-214	177
-1448-212	179	-1447-203	188	-1446-199	190	-1445-194	191
-1444-190	193	-1443-187	197	-1442-183	201	-1441-180	204
-1440-179	205	-1439-178	207	-1438-177	209	-1437-176	211
-1436-178	216	-1435-180	216	-1434-181	217	-1433-184	220
-1432-185	220	-1431-188	220	-1430-191	221	-1429-195	226
-1428-200	227	-1427-207	227	-1426-212	227	-1425-220	230
-1424-231	232	-1423-239	233	-1422-249	235	-1421-264	242
-1420-276	246	-1419-290	252	-1418-308	257	-1417-325	272
-1416-341	286	-1415-343	302	-1414-336	318	-1413-314	345
-1412-304	356	-1411-288	2	-1410-277	12	-1409-268	14
-1408-262	15	-1407-255	19	-1406-252	19	-1405-249	19
-1404-248	19	-1403-247	19	-1402-246	19	-1401-242	19

-1400-252	19	-1399-254	19	-1398-258	19	-1397-262	19
-1396-262	18	-1395-267	18	-1394-272	16	-1393-279	15
-1392-263	12	-1391-285	8	-1390-291	4	-1389-293	360
-1388-297	347	-1387-297	337	-1386-297	331	-1385-301	320
-1384-296	315	-1383-297	307	-1382-295	297	-1381-298	295
-1380-297	292	-1379-302	287	-1378-301	286	-1377-309	284
-1376-312	281	-1375-320	279	-1374-329	276	-1373-340	271
-1372-349	268	-1371-366	263	-1370-384	254	-1369-393	249
-1368-392	233	-1367-372	213	-1366-349	178	-1365-323	150
-1364-309	158	-1363-294	135	-1362-281	128	-1361-269	125
-1360-256	125	-1359-250	122	-1358-243	120	-1357-239	119
-1356-235	118	-1355-232	117	-1354-230	116	-1353-228	115
-1352-227	115	-1351-230	114	-1350-232	113	-1349-234	113
-1348-237	112	-1347-243	112	-1346-249	112	-1345-256	111
-1344-262	111	-1343-278	111	-1342-288	111	-1341-304	110
-1340-345	111	-1339-373	117	-1338-599	120	-1337-400	170
-1336-394	238	-1335-332	285	-1334-307	285	-1333-281	285
-1332-263	283	-1331-254	283	-1330-245	281	-1329-232	281
-1328-226	281	-1327-220	281	-1326-214	281	-1325-210	281
-1324-209	281	-1323-206	281	-1322-204	281	-1321-205	281
-1320-207	281	-1319-209	281	-1318-211	281	-1317-216	281
-1316-219	285	-1315-229	285	-1314-235	285	-1313-240	288
-1312-253	293	-1311-265	297	-1310-278	301	-1309-294	301
-1308-314	310	-1307-331	327	-1306-335	335	-1305-331	12
-1304-316	43	-1303-299	54	-1302-284	57	-1301-263	68
-1300-253	75	-1299-244	77	-1298-233	77	-1297-227	76
-1296-222	79	-1295-218	80	-1294-216	80	-1293-215	81
-1292-215	81	-1291-216	81	-1290-219	82	-1289-220	82
-1288-226	82	-1287-229	82	-1286-238	82	-1285-245	82
-1284-252	82	-1283-266	83	-1282-278	83	-1281-289	83
-1280-317	83	-1279-339	83	-1278-368	81	-1277-400	79
-1276-400	78	-1275-400	78	-1274-362	72	-1273-362	72
-1272-338	68	-1271-322	66	-1270-300	66	-1269-290	65
-1268-280	66	-1267-274	74	-1266-268	92	-1265-262	143
-1264-256	251	-1263-253	263	-1262-254	263	-1261-254	263
-1260-254	261	-1259-252	262	-1258-252	261	-1257-256	259
-1256-254	257	-1255-253	254	-1254-253	250	-1253-253	247
-1252-253	244	-1251-251	239	-1250-251	236	-1249-255	231
-1248-253	228	-1247-256	227	-1246-259	226	-1245-262	225
-1244-267	224	-1243-276	223	-1242-281	222	-1241-288	222
-1240-303	222	-1239-313	222	-1238-332	234	-1237-344	243
-1236-349	257	-1235-348	275	-1234-333	287	-1233-320	291
-1232-295	308	-1231-282	313	-1230-271	313	-1229-256	315
-1228-248	319	-1227-242	320	-1226-234	322	-1225-229	324
-1224-224	328	-1223-221	330	-1222-220	330	-1221-218	331
-1220-217	332	-1219-218	335	-1218-222	338	-1217-224	338
-1216-227	339	-1215-236	347	-1214-241	350	-1213-248	351
-1212-261	5	-1211-271	5	-1210-280	12	-1209-297	19
-1208-306	29	-1207-316	49	-1206-315	71	-1205-310	83
-1204-292	111	-1203-281	127	-1202-270	134	-1201-256	137
-1200-249	144	-1199-241	151	-1198-232	151	-1197-227	151
-1196-223	158	-1195-220	162	-1194-219	162	-1193-218	163
-1192-218	167	-1191-221	167	-1190-223	168	-1189-225	176
-1188-230	177	-1187-237	180	-1186-241	182	-1185-246	183
-1184-252	197	-1183-261	199	-1182-269	202	-1181-273	214
-1180-278	232	-1179-279	243	-1178-277	257	-1177-272	273
-1176-266	278	-1175-263	281	-1174-252	296	-1173-250	295
-1172-245	302	-1171-241	311	-1170-240	310	-1169-242	314

-1168-239	318	-1167-239	321	-1156-244	325	-1165-245	336
-1164-249	337	-1163-255	331	-1162-260	353	-1161-265	359
-1160-269	16	-1159-274	21	-1158-272	31	-1157-269	54
-1156-265	57	-1155-261	63	-1154-251	89	-1153-247	98
-1152-240	101	-1151-233	105	-1150-224	123	-1149-220	127
-1148-216	127	-1147-212	131	-1146-208	148	-1145-207	148
-1144-206	148	-1143-205	158	-1142-204	158	-1141-209	158
-1140-207	163	-1139-206	169	-1138-212	174	-1137-216	174
-1136-216	181	-1135-218	196	-1134-217	198	-1133-217	199
-1132-213	220	-1131-211	224	-1130-208	226	-1129-202	243
-1128-198	248	-1127-195	250	-1126-189	265	-1125-187	266
-1124-182	267	-1123-179	276	-1122-176	278	-1121-175	279
-1120-174	287	-1119-175	289	-1118-179	290	-1117-176	297
-1116-183	297	-1115-185	298	-1114-185	303	-1113-191	306
-1112-197	308	-1111-200	317	-1110-206	321	-1109-211	327
-1108-212	345	-1107-214	350	-1106-213	8	-1105-208	21
-1104-201	36	-1103-197	40	-1102-193	45	-1101-183	57
-1100-178	61	-1099-172	67	-1098-166	76	-1097-163	81
-1096-159	82	-1095-155	84	-1094-152	90	-1093-151	92
-1092-149	96	-1091-150	100	-1090-151	102	-1089-153	111
-1088-156	114	-1087-159	114	-1086-162	120	-1085-166	126
-1084-171	128	-1083-176	132	-1082-181	142	-1081-187	145
-1080-190	159	-1079-192	173	-1078-193	174	-1077-188	186
-1076-183	197	-1075-177	202	-1074-169	211	-1073-161	220
-1072-154	229	-1071-148	236	-1070-141	238	-1069-136	243
-1068-132	250	-1067-130	251	-1066-126	252	-1065-123	257
-1064-121	264	-1063-121	264	-1062-121	269	-1061-121	270
-1060-124	270	-1059-125	277	-1058-128	277	-1057-131	281
-1056-136	283	-1055-139	288	-1054-143	294	-1053-147	295
-1052-152	304	-1051-154	315	-1050-157	316	-1049-157	318
-1048-152	335	-1047-148	352	-1046-142	359	-1045-137	3
-1044-130	25	-1043-126	30	-1042-119	33	-1041-115	45
-1040-112	45	-1039-108	48	-1038-104	49	-1037-101	50
-1036-99	56	-1035-98	57	-1034-97	59	-1033-97	65
-1032-100	66	-1031-103	66	-1030-105	74	-1029-106	84
-1028-113	83	-1027-117	91	-1026-124	92	-1025-128	105
-1024-135	115	-1023-142	115	-1022-144	132	-1021-146	152
-1020-147	155	-1019-143	160	-1018-135	187	-1017-130	189
-1016-120	191	-1015-114	204	-1014-107	204	-1013-99	215
-1012-94	222	-1011-90	222	-1010-85	225	-1009-80	233
-1008-78	233	-1007-76	234	-1006-74	244	-1005-74	245
-1004-75	245	-1003-75	253	-1002-80	254	-1001-82	254
-1000-86	260	-999-90	260	-998-95	270	-997-101	278
-996-108	278	-995-113	288	-994-120	293	-993-124	294
-992-129	311	-991-131	313	-990-128	322	-989-123	340
-988-118	342	-987-111	348	-986-102	8	-985-96	21
-984-89	24	-983-83	32	-982-78	41	-981-74	41
-980-70	48	-979-68	52	-978-65	53	-977-64	59
-976-63	59	-975-63	65	-974-65	67	-973-69	67
-972-72	72	-971-74	80	-970-79	82	-969-82	85
-968-87	100	-967-92	106	-966-96	116	-965-99	135
-964-101	137	-963-100	148	-962-94	158	-961-90	166
-960-84	179	-959-78	181	-958-72	187	-957-66	197
-956-58	202	-955-54	204	-954-48	212	-953-44	215
-952-40	219	-951-37	227	-950-35	228	-949-34	229
-948-32	234	-947-32	236	-946-33	239	-945-35	246
-944-39	246	-943-42	247	-942-45	253	-941-49	254
-940-54	259	-939-60	267	-938-70	267	-937-78	272

-936	-89	285	-935	-97	291	-934	-108	299	-933	-114	308
-932	-118	322	-931	-112	336	-930	-99	352	-929	-87	6
-928	-71	21	-927	-62	26	-926	-49	39	-925	-40	43
-924	-29	44	-923	-20	50	-922	-11	57	-921	-7	57
-920	0	58	-919	6	61	-918	11	62	-917	16	64
-916	21	67	-915	24	67	-914	29	68	-913	32	69
-912	35	69	-911	38	72	-910	40	74	-909	42	74
-908	44	74	-907	46	76	-906	47	76	-905	49	76
-904	49	78	-903	49	78	-902	50	78	-901	50	79
-900	48	79	-899	47	80	-898	46	80	-897	46	79
-896	45	79	-895	42	80	-894	42	80	-893	40	80
-892	37	79	-891	36	78	-890	33	78	-889	31	79
-888	28	79	-887	26	79	-886	23	79	-885	18	77
-884	15	77	-883	12	77	-882	5	77	-881	1	76
-880	-4	73	-879	-11	73	-878	-18	71	-877	-26	70
-876	-35	70	-875	-43	69	-874	-52	67	-873	-62	66
-872	-76	63	-871	-89	61	-870	-106	57	-869	-119	52
-868	-139	41	-867	-152	28	-866	-153	2	-865	-142	342
-864	-123	315	-863	-113	307	-862	-94	302	-861	-85	297
-860	-74	290	-859	-67	289	-858	-59	284	-857	-55	283
-856	-51	282	-855	-47	275	-854	-44	275	-853	-43	275
-852	-42	273	-851	-42	272	-850	-42	271	-849	-46	267
-848	-49	267	-847	-51	266	-846	-57	264	-845	-61	262
-844	-66	261	-843	-71	259	-842	-82	256	-841	-89	255
-840	-98	253	-839	-108	249	-838	-121	243	-837	-140	234
-836	-153	227	-835	-164	217	-834	-171	195	-833	-163	181
-832	-122	163	-831	-136	147	-830	-126	135	-829	-116	128
-828	-107	121	-827	-101	115	-826	-96	108	-825	-91	106
-824	-86	102	-823	-83	98	-822	-81	97	-821	-80	94
-820	-81	92	-819	-82	91	-818	-86	88	-817	-89	86
-816	-92	84	-815	-96	82	-814	-101	80	-813	-107	77
-812	-117	69	-811	-122	66	-810	-129	60	-809	-135	54
-808	-140	45	-807	-145	36	-806	-147	13	-805	-145	2
-804	-140	351	-803	-136	344	-802	-130	334	-801	-125	328
-800	-120	325	-799	-115	320	-798	-109	314	-797	-106	312
-796	-104	309	-795	-102	304	-794	-100	302	-793	-99	301
-792	-99	297	-791	-99	294	-790	-101	291	-789	-104	288
-788	-106	282	-787	-108	280	-786	-111	276	-785	-113	271
-784	-117	265	-783	-120	259	-782	-122	252	-781	-125	247
-780	-126	241	-779	-128	230	-778	-128	224	-777	-128	220
-776	-125	215	-775	-123	207	-774	-121	198	-773	-118	194
-772	-117	187	-771	-117	182	-770	-116	178	-769	-115	174
-768	-115	171	-767	-115	169	-766	-116	168	-765	-120	163
-764	-123	158	-763	-124	154	-762	-130	148	-761	-133	142
-760	-136	136	-759	-140	130	-758	-144	125	-757	-150	119
-756	-154	112	-755	-156	109	-754	-159	105	-753	-161	97
-752	-162	87	-751	-160	80	-750	-156	69	-749	-153	59
-748	-151	50	-747	-148	40	-746	-145	31	-745	-140	16
-744	-138	11	-743	-135	7	-742	-133	4	-741	-131	360
-740	-129	358	-739	-128	354	-738	-128	350	-737	-129	348
-736	-131	346	-735	-133	343	-734	-134	338	-733	-134	337
-732	-136	332	-731	-136	329	-730	-137	328	-729	-137	321
-728	-138	317	-727	-139	314	-726	-139	310	-725	-139	305
-724	-139	301	-723	-139	297	-722	-138	290	-721	-138	287
-720	-136	281	-719	-135	277	-718	-136	273	-717	-139	266
-716	-140	263	-715	-141	258	-714	-144	253	-713	-145	251
-712	-148	246	-711	-150	243	-710	-153	242	-709	-157	238
-708	-164	232	-707	-167	228	-706	-172	222	-705	-175	218

-704-179	215	-703-182	204	-702-182	193	-701-181	189
-700-178	182	-699-175	172	-698-169	158	-697-164	150
-696-160	143	-695-156	136	-694-150	127	-693-146	123
-692-143	119	-691-140	114	-690-138	112	-689-136	110
-688-135	106	-687-135	105	-686-135	103	-685-136	99
-684-140	98	-683-143	95	-682-146	93	-681-149	90
-680-153	87	-679-158	84	-678-163	79	-677-166	77
-676-174	65	-675-177	60	-674-181	53	-673-185	37
-672-153	28	-671-182	21	-670-175	8	-669-171	4
-668-166	359	-667-161	355	-666-157	352	-665-153	347
-664-148	344	-663-145	344	-662-141	336	-661-139	335
-660-138	332	-659-137	329	-658-137	329	-657-137	327
-656-140	321	-655-143	321	-654-146	319	-653-149	316
-652-152	313	-651-160	310	-650-164	305	-649-169	300
-648-177	292	-647-181	285	-646-184	278	-645-188	271
-644-190	264	-643-189	254	-642-183	238	-641-178	232
-640-174	226	-639-169	221	-638-155	215	-637-160	209
-636-156	205	-635-152	202	-634-147	197	-633-146	192
-632-144	190	-631-142	188	-630-142	186	-629-142	184
-628-143	181	-627-148	177	-626-150	173	-625-153	170
-624-157	168	-623-163	164	-622-158	159	-621-173	159
-620-179	156	-619-185	150	-618-193	143	-617-199	140
-616-204	136	-615-210	114	-614-210	108	-613-210	104
-612-206	90	-611-201	78	-610-196	75	-609-190	68
-608-188	54	-607-182	49	-606-179	48	-605-177	38
-604-172	29	-603-172	26	-602-172	22	-601-172	19
-600-172	21	-599-174	23	-598-179	13	-597-180	11
-596-184	18	-595-191	11	-594-196	5	-593-207	5
-592-207	5	-591-215	3	-590-224	1	-589-232	360
-588-243	355	-587-253	351	-586-265	350	-585-273	339
-584-275	90	-583-276	201	-582-278	312	-581-272	289
-580-268	278	-579-260	277	-578-257	262	-577-250	255
-576-247	256	-575-245	245	-574-242	246	-573-240	247
-572-243	241	-571-245	242	-570-246	246	-569-251	247
-568-255	244	-567-262	244	-566-267	246	-565-274	245
-564-280	243	-563-286	245	-562-296	247	-561-308	247
-560-315	248	-559-329	249	-558-350	250	-557-367	258
-558-383	266	-555-400	274	-554-400	280	-553-400	291
-552-400	308	-551-400	348	-550-400	59	-549-381	119
-548-364	120	-547-347	142	-546-336	147	-545-317	142
-544-308	143	-543-298	145	-542-293	142	-541-287	142
-540-279	147	-539-276	147	-538-270	146	-537-266	151
-536-262	152	-535-262	154	-534-263	157	-533-263	160
-532-268	158	-531-267	158	-530-271	159	-529-277	158
-528-283	156	-527-289	154	-526-297	158	-525-317	148
-524-327	149	-523-348	154	-522-369	147	-521-386	144
-520-389	141	-519-364	129	-518-346	114	-517-328	94
-516-306	74	-515-294	53	-514-283	42	-513-274	39
-512-260	22	-511-251	22	-510-243	23	-509-239	15
-508-239	18	-507-232	35	-506-234	34	-505-239	24
-504-237	27	-503-240	27	-502-245	19	-501-251	19
-500-254	27	-499-266	20	-498-271	13	-497-288	36
-496-306	29	-495-328	15	-494-350	19	-493-380	36
-492-400	42	-491-400	101	-490-398	189	-489-351	214
-488-323	202	-487-306	211	-486-281	213	-485-269	195
-484-263	199	-483-248	224	-482-244	208	-481-237	199
-480-233	221	-479-233	216	-478-234	199	-477-230	207
-476-230	216	-475-233	200	-474-235	200	-473-238	207

-472-245	200	-471-248	199	470-258	205	469-271	196
-466-279	193	-467-291	193	466-305	187	465-323	178
-464-333	177	-463-344	165	462-343	153	451-319	129
-460-307	121	-459-289	96	458-279	78	457-260	71
-456-254	67	-455-244	59	454-237	59	453-230	56
-452-227	57	-451-224	55	450-221	55	449-219	55
-448-219	54	-447-219	54	446-219	54	445-225	51
-444-228	51	-443-232	54	442-238	53	441-246	49
-440-251	49	-439-261	54	438-270	51	437-264	53
-436-300	60	-435-324	51	434-342	55	433-378	67
-432-400	67	-431-400	72	430-400	98	429-376	212
-428-346	260	-427-319	269	426-301	281	425-289	274
-424-278	267	-423-271	287	422-266	276	421-257	272
-420-255	288	-419-254	284	418-252	272	417-250	288
-416-248	300	-415-251	283	414-248	296	413-246	306
-412-247	290	-411-253	303	410-251	315	409-249	304
-408-254	312	-407-254	332	406-252	327	405-252	323
-404-248	343	-403-249	341	402-252	341	401-249	358
-400-247	359	-399-250	359	398-249	359	397-251	359
-396-252	359	-395-255	360	394-258	360	393-262	360
-392-264	360	-391-271	1	390-262	1	389-289	1
-388-302	1	-387-308	355	386-326	351	385-334	342
-384-336	326	-383-326	310	382-315	290	381-297	279
-380-278	273	-379-262	259	378-250	253	377-236	253
-376-224	239	-375-217	230	374-208	237	373-201	227
-372-195	219	-371-190	228	370-187	222	369-162	220
-368-179	230	-367-176	228	366-175	218	365-173	218
-364-171	223	-363-171	219	362-173	211	361-175	213
-360-173	222	-359-177	214	358-179	204	357-181	228
-356-184	202	-355-186	222	354-191	209	353-195	196
-352-200	205	-351-206	208	350-210	196	349-215	181
-348-217	180	-347-220	180	346-222	179	345-225	160
-344-221	152	-343-219	160	342-217	144	341-217	144
-340-217	133	-339-215	124	338-208	127	337-204	130
-336-203	115	-335-200	102	334-196	99	333-191	106
-332-193	98	-331-194	84	330-188	84	329-189	97
-328-192	79	-327-186	109	326-194	75	325-190	88
-324-195	104	-323-200	90	322-201	75	321-204	88
-320-207	101	-319-216	87	318-219	71	317-220	98
-316-231	105	-315-241	84	314-245	104	313-254	104
-312-269	77	-311-272	98	310-294	94	309-306	80
-308-318	108	-307-336	111	306-350	104	305-368	108
-304-375	142	-303-367	140	302-373	145	301-368	179
-300-348	171	-299-343	159	298-354	180	297-337	200
-296-325	179	-295-332	175	294-336	188	293-331	187
-292-330	168	-291-336	158	290-330	159	289-326	152
-288-319	131	-287-308	125	286-308	125	285-299	102
-284-288	103	-283-279	94	282-269	87	281-255	90
-280-250	79	-279-240	73	278-232	73	277-224	82
-276-219	63	-275-214	71	274-208	65	273-202	65
-272-199	65	-271-195	64	270-192	64	269-188	63
-268-184	63	-267-184	60	266-183	58	265-181	58
-264-177	66	-263-182	56	262-182	53	261-177	56
-260-177	56	-259-181	56	258-185	52	257-185	51
-256-186	52	-255-190	48	254-191	47	253-196	43
-252-196	42	-251-201	40	250-204	36	249-207	34
-248-209	34	-247-212	34	246-214	29	245-216	24
-244-218	19	-243-220	14	242-222	10	241-222	2

-240-221	354	-239-220	348	-238-217	344	-237-218	339
-236-217	335	-235-215	334	-234-212	331	-233-212	325
-232-210	321	-231-206	318	-230-207	315	-229-206	311
-228-204	311	-227-207	308	-226-206	306	-225-207	301
-224-208	300	-223-205	300	-222-207	298	-221-212	296
-220-212	295	-219-215	293	-218-218	293	-217-223	291
-216-228	290	-215-233	290	-214-237	289	-213-242	289
-212-247	288	-211-257	288	-210-266	286	-209-276	287
-208-269	286	-207-306	285	-206-324	284	-205-380	286
-204-400	297	-203-400	338	-202-392	31	-201-350	55
-200-312	59	-199-291	58	-198-271	57	-197-260	56
-196-252	53	-195-248	52	-194-246	52	-193-240	51
-192-236	51	-191-231	46	-190-227	47	-189-222	47
-188-219	46	-187-215	45	-186-213	44	-185-209	41
-184-207	38	-183-205	37	-182-203	37	-181-200	31
-180-198	31	-179-196	28	-178-196	22	-177-193	21
-176-192	13	-175-192	10	-174-188	10	-173-187	10
-172-186	4	-171-184	3	-170-181	3	-169-180	359
-168-178	356	-167-176	355	-166-173	354	-165-171	348
-164-169	346	-163-165	344	-162-163	338	-161-161	335
-160-157	335	-159-155	331	-158-153	323	-157-150	323
-156-148	319	-155-146	313	-154-142	319	-153-141	306
-152-139	310	-151-136	313	-150-134	317	-149-134	309
-148-132	305	-147-131	307	-146-129	305	-145-130	298
-144-131	292	-143-128	294	-142-127	292	-141-128	283
-140-125	285	-139-125	287	-138-128	279	-137-129	277
-136-126	285	-135-128	275	-134-130	269	-133-129	277
-132-130	272	-131-133	264	-130-133	269	-129-134	270
-128-137	259	-127-137	265	-126-140	265	-125-142	256
-124-144	256	-123-146	260	-122-150	259	-121-154	250
-120-156	250	-119-160	251	-118-164	245	-117-171	245
-116-176	243	-115-181	242	-114-187	242	-113-196	240
-112-203	238	-111-212	238	-110-221	237	-109-237	230
-108-249	229	-107-264	228	-106-280	219	-105-296	205
-104-309	200	-103-316	179	-102-301	157	-101-287	136
-100-140	189	-99-145	186	-98-149	132	-97-148	179
-96-154	175	-95-162	171	-94-162	165	-93-167	158
-92-170	152	-91-171	145	-90-169	140	-89-176	134
-88-183	127	-87-186	120	-86-181	114	-85-183	107
-84-187	95	-83-184	82	-82-174	77	-81-171	62
-80-165	60	-79-157	57	-78-150	53	-77-140	54
-76-136	50	-75-133	44	-74-126	42	-73-117	41
-72-111	40	-71-105	36	-70-96	33	-69-93	31
-68-91	23	-67-86	21	-66-81	20	-65-73	16
-64-70	21	-63-57	8	-62-63	19	-61-56	30
-60-55	29	-59-49	355	-58-45	8	-57-40	42
-56-43	6	-55-37	358	-54-30	39	-53-33	18
-52-31	353	-51-20	44	-50-24	27	-49-24	358
-48-16	19	-47-13	37	-46-15	7	-45-8	13
-44-7	28	-43-9	358	-42-5	345	-41-1	25
-40-1	22	-39-2	345	-38-3	2	-37-9	18
-36-7	4	-35-7	338	-34-14	9	-33-13	355
-32-11	333	-31-18	10	-30-16	360	-29-14	333
-28-21	355	-27-23	11	-26-19	336	-25-24	342
-24-27	357	-23-24	336	-22-24	330	-21-29	352
-20-27	337	-19-26	333	-18-32	350	-17-32	346
-16-29	330	-15-30	334	-14-35	358	-13-30	334
-12-34	338	-11-37	338	-10-32	340	-9-34	337

-8	38	0	-7	32	335	-6	36	333	-5	40	354
-4	38	351	-3	35	331	-2	37	330	-1	41	358
0	36	342	1	36	332	2	42	332	3	40	347
4	36	334	5	42	347	6	41	340	7	37	331
8	40	344	9	40	348	10	39	341	11	38	332
12	42	355	13	35	340	14	35	334	15	41	356
16	34	339	17	35	339	18	40	334	19	36	348
20	32	333	21	37	353	22	37	358	23	31	344
24	31	334	25	37	6	26	30	355	27	30	342
28	33	353	29	28	347	30	26	345	31	26	348
32	24	347	33	23	347	34	23	347	35	21	349
36	20	347	37	19	346	38	19	351	39	17	350
40	14	349	41	15	352	42	11	351	43	10	353
44	10	356	45	7	354	46	4	353	47	4	352
48	3	352	49	-1	352	50	-2	353	51	-5	354
52	-6	355	53	-8	352	54	-11	353	55	-13	354
56	-15	355	57	-18	354	58	-20	354	59	-23	354
60	-25	354	61	-27	355	62	-31	356	63	-34	356
64	-36	355	65	-38	356	66	-42	356	67	-45	353
68	-49	6	69	-54	9	70	-57	1	71	-60	2
72	-63	9	73	-67	5	74	-71	2	75	-75	14
76	-80	18	77	-84	5	78	-88	14	79	-97	16
80-100	359		81-104	359		82-113	24		83-127	15	
84-129	7		85-134	25		86-144	35		87-154	14	
88-160	38		89-176	23		90-181	11		91-187	52	
92-210	39		93-230	20		94-240	24		95-235	68	
96-246	78		97-307	70		98-273	107		99-132	214	
100-132	215		101-132	215		102-133	215		103-134	215	
104-134	215		105-135	215		106-136	215		107-136	216	
108-137	216		109-138	215		110-138	215		111-139	216	
112-140	216		113-142	216		114-143	218		115-145	219	
116-146	220		117-147	220		118-148	220		119-150	220	
120-151	221		121-153	223		122-154	224		123-156	225	
124-157	226		125-159	228		126-161	226		127-162	228	
128-164	233		129-166	233		130-169	233		131-170	234	
132-172	236		133-174	238		134-176	240		135-179	242	
136-180	244		137-182	247		138-183	249		139-184	254	
140-185	256		141-185	258		142-186	260		143-186	262	
144-187	264		145-185	265		146-186	270		147-184	272	
148-183	275		149-182	275		150-180	277		151-179	282	
152-179	283		153-177	285		154-175	268		155-172	290	
156-170	293		157-169	295		158-167	298		159-166	299	
160-164	299		161-162	299		162-160	301		163-159	302	
164-157	303		165-155	303		166-153	303		167-152	306	
168-150	306		169-149	306		170-148	306		171-146	307	
172-145	307		173-144	308		174-143	311		175-142	311	
176-141	311		177-141	312		178-140	313		179-139	313	
180-138	311		181-138	312		182-137	317		183-137	312	
184-136	314		185-136	319		186-136	313		187-136	314	
188-137	314		189-137	314		190-138	314		191-140	315	
192-140	316		193-141	316		194-142	316		195-143	316	
196-144	317		197-144	318		198-145	319		199-146	320	
200-147	322		201-148	324		202-150	324		203-152	325	
204-154	325		205-155	327		206-158	330		207-160	330	
208-162	330		209-165	333		210-167	333		211-169	335	
212-171	341		213-174	343		214-176	344		215-178	344	
216-180	348		217-182	355		218-183	356		219-186	356	
220-186	2		221-187	5		222-188	10		223-190	11	

224-189	15	225-187	20	226-185	30	227-184	30
228-184	32	229-182	36	230-182	39	231-181	40
232-178	41	233-175	45	234-173	47	235-171	51
236-170	53	237-169	54	238-166	57	239-164	57
240-162	61	241-161	61	242-159	62	243-156	62
244-156	64	245-155	67	246-155	67	247-153	248
248-152	68	249-151	71	250-150	71	251-149	71
252-149	72	253-149	73	254-148	73	255-148	75
256-147	76	257-147	76	258-148	76	259-149	76
260-151	78	261-153	78	262-154	80	263-156	81
264-157	82	265-158	83	266-160	84	267-161	86
268-162	87	269-164	88	270-166	89	271-168	92
272-170	95	273-172	95	274-173	97	275-175	100
276-177	101	277-178	107	278-180	107	279-181	107
280-182	115	281-183	120	282-184	121	283-184	128
284-184	131	285-182	133	286-180	139	287-181	146
288-179	151	289-176	158	290-174	159	291-173	163
292-169	169	293-168	170	294-166	171	295-164	176
296-162	178	297-160	179	298-159	179	299-157	182
300-156	184	301-153	185	302-152	188	303-150	190
304-149	190	305-148	195	306-147	195	307-146	195
308-145	197	309-146	199	310-146	199	311-145	200
312-144	200	313-144	202	314-145	204	315-147	205
316-149	207	317-150	207	318-151	211	319-152	214
320-152	213	321-154	214	322-156	216	323-157	217
324-159	220	325-161	222	326-163	223	327-165	227
328-167	226	329-170	228	330-170	231	331-173	234
332-175	236	333-177	243	334-178	245	335-179	247
336-180	256	337-181	259	338-181	261	339-181	265
340-181	271	341-179	279	342-177	281	343-176	288
344-175	290	345-173	294	346-172	300	347-169	301
348-168	305	349-165	312	350-163	312	351-160	317
352-158	317	353-155	321	354-153	324	355-152	325
356-150	326	357-147	329	358-146	329	359-146	333
360-145	334	361-144	334	362-143	335	363-143	337
364-142	338	365-142	340	366-143	342	367-143	343
368-145	344	369-148	347	370-149	349	371-150	351
372-150	352	373-151	353	374-153	353	375-155	355
376-157	358	377-159	1	378-161	3	379-163	7
380-165	10	381-169	14	382-172	16	383-174	22
384-175	25	385-177	27	386-178	29	387-181	35
388-182	42	389-183	43	390-183	53	391-182	59
392-182	64	393-180	70	394-177	74	395-175	78
396-174	83	397-172	87	398-170	93	399-167	96
400-165	99	401-163	100	402-161	103	403-159	106
404-157	108	405-154	110	406-153	112	407-151	114
408-150	116	409-150	118	410-149	119	411-148	119
412-148	124	413-148	124	414-147	125	415-148	125
416-148	125	417-151	129	418-152	130	419-154	132
420-155	132	421-156	133	422-157	138	423-160	140
424-163	141	425-165	142	426-167	144	427-170	148
428-172	151	429-175	153	430-177	155	431-179	159
432-181	162	433-183	164	434-184	171	435-186	177
436-186	182	437-185	183	438-185	195	439-183	200
440-180	209	441-178	216	442-176	219	443-174	223
444-172	230	445-169	232	446-166	238	447-163	238
448-160	244	449-157	251	450-156	252	451-153	252
452-152	254	453-150	257	454-149	257	455-146	265

456-146	264	457-145	265	458-144	270	459-144	271
460-144	270	461-145	270	462-146	273	463-148	275
464-149	278	465-150	279	466-152	284	467-154	284
468-156	284	469-158	290	470-159	291	471-161	295
472-165	297	473-167	302	474-170	305	475-172	311
476-175	314	477-177	321	478-180	326	479-182	331
480-183	337	481-184	351	482-185	356	483-186	357
484-182	10	485-180	10	486-178	13	487-175	23
488-173	25	489-170	27	490-167	29	491-164	38
492-162	40	493-159	41	494-156	43	495-154	49
496-153	49	497-150	52	498-148	55	499-147	56
500-146	58	501-145	60	502-144	62	503-144	65
504-143	69	505-146	69	506-148	70	507-146	75
508-151	77	509-151	77	510-154	80	511-155	82
512-157	84	513-160	90	514-162	92	515-164	94
516-167	102	517-170	106	518-172	108	519-176	117
520-178	123	521-180	126	522-181	136	523-181	141
524-182	146	525-182	151	526-180	159	527-176	167
528-173	51	529-171	295	530-168	179	531-165	182
532-163	185	533-160	187	534-157	189	535-154	190
536-151	196	537-149	197	538-147	200	539-146	201
540-144	202	541-141	203	542-140	206	543-140	205
544-139	211	545-138	213	546-138	216	547-139	216
548-141	217	549-143	219	550-145	223	551-146	223
552-148	229	553-150	233	554-153	237	555-156	237
556-158	241	557-162	247	558-166	250	559-168	256
560-171	258	561-174	269	562-176	277	563-178	283
564-180	290	565-180	299	566-180	305	567-179	309
568-176	318	569-176	318	570-174	323	571-171	328
572-169	336	573-166	340	574-163	345	575-161	350
576-158	353	577-154	359	578-152	360	579-150	2
580-146	10	581-146	11	582-143	14	583-142	19
584-141	21	585-141	23	586-140	25	587-140	26
588-140	30	589-142	31	590-144	35	591-146	37
592-147	41	593-149	42	594-151	45	595-153	49
596-156	51	597-159	54	598-162	58	599-165	62
600-171	72	601-174	77	602-177	81	603-180	86
604-182	90	605-184	96	606-185	102	607-187	107
608-184	116	609-182	120	610-180	126	611-177	128
612-174	137	613-170	143	614-165	148	615-162	152
616-159	156	617-156	160	618-153	166	619-150	171
620-149	177	621-147	175	622-145	179	623-143	181
624-142	185	625-142	190	626-142	192	627-142	193
628-144	194	629-146	196	630-148	199	631-150	201
632-152	203	633-154	205	634-157	210	635-160	212
636-163	213	637-166	220	638-171	223	639-176	227
640-181	232	641-185	236	642-188	239	643-192	245
644-194	250	645-196	253	646-196	266	647-195	269
648-191	276	649-186	279	650-185	289	651-181	293
652-177	302	653-173	311	654-169	314	655-165	317
656-161	321	657-157	327	658-154	329	659-152	334
660-149	337	661-148	339	662-147	340	663-146	342
664-144	344	665-144	346	666-145	348	667-145	350
668-149	352	669-150	355	670-152	356	671-154	357
672-157	359	673-160	360	674-164	4	675-169	6
676-172	9	677-177	11	678-186	16	679-191	21
680-197	26	681-202	32	682-207	40	683-213	47
684-218	55	685-220	72	686-220	90	687-215	100

688-211	109	689-206	118	690-201	124	691-196	130
692-190	136	693-185	139	694-179	142	695-175	144
696-168	146	697-165	152	698-163	154	699-161	157
700-156	156	701-157	160	702-156	162	703-155	164
704-155	164	705-155	167	706-158	167	707-160	169
708-164	173	709-166	175	710-169	177	711-171	179
712-174	181	713-178	187	714-187	193	715-192	199
716-197	205	717-202	211	718-208	223	719-212	234
720-215	240	721-216	256	722-215	262	723-209	271
724-203	274	725-197	287	726-190	288	727-183	293
728-176	296	729-169	298	730-165	301	731-161	303
732-157	306	733-152	307	734-148	309	735-143	314
736-140	314	737-138	315	738-135	318	739-134	320
740-132	320	741-132	323	742-132	324	743-134	326
744-135	327	745-137	328	746-138	334	747-141	334
748-144	335	749-146	336	750-151	340	751-154	342
752-158	346	753-162	350	754-166	354	755-171	358
756-177	5	757-183	14	758-192	26	759-195	34
760-197	41	761-200	48	762-200	61	763-195	71
764-191	77	765-187	83	766-181	93	767-176	100
768-170	102	769-165	108	770-156	117	771-156	118
772-153	116	773-149	124	774-147	126	775-143	128
776-141	132	777-141	133	778-140	136	779-140	136
780-140	141	781-145	142	782-147	142	783-149	145
784-152	147	785-156	149	786-159	152	787-167	155
788-173	157	789-180	161	790-169	165	791-198	167
792-215	176	793-226	184	794-234	199	795-242	213
796-250	228	797-246	245	798-233	266	799-221	278
800-209	288	801-196	295	802-184	298	803-174	303
804-165	306	805-157	308	806-150	310	807-144	312
808-139	313	809-133	316	810-130	316	811-128	317
812-125	317	813-124	319	814-123	319	815-122	320
816-123	322	817-125	322	818-127	324	819-130	324
820-133	325	821-137	325	822-141	327	823-148	328
824-154	328	825-163	331	826-174	331	827-186	332
828-203	334	829-223	339	830-249	349	831-281	5
832-304	35	833-283	117	834-246	124	835-218	126
836-194	132	837-175	138	838-159	139	839-141	140
840-152	141	841-124	142	842-116	141	843-111	145
844-103	146	845-98	145	846-93	146	847-89	146
848-86	147	849-84	147	850-80	147	851-78	148
852-77	148	853-76	149	854-76	149	855-75	149
856-78	150	857-81	150	858-84	151	859-87	151
860-91	152	861-95	152	862-104	152	863-110	154
864-118	155	865-126	157	866-142	161	867-154	164
868-176	172	869-196	163	870-225	217	871-229	248
872-212	280	873-187	296	874-151	307	875-132	314
876-116	319	877-96	321	878-84	321	879-74	322
880-81	323	881-53	324	882-46	325	883-36	328
884-30	329	885-23	329	886-17	330	887-13	328
888-8	329	889-2	330	890-1	330	891-3	329
892-8	328	893-10	329	894-13	328	895-15	329
896-17	330	897-19	330	898-22	330	899-24	330
900-24	330	901-25	330	902-26	331	903-26	331
904-27	331	905-27	332	906-26	330	907-24	330
908-22	330	909-21	331	910-20	332	911-18	332
912-17	333	913-15	332	914-13	333	915-11	332
916-7	331	917-5	332	918-2	332	919-1	331

920 -5 331	921 -9 332	922 -13 330	923 -17 329
924 -22 330	925 -27 328	926 -32 327	927 -34 326
928 -45 326	929 -45 326	930 -60 326	931 -69 324
932 -77 322	933 -88 319	934 -98 317	935-110 314
936-122 310	937-134 304	938-149 300	939-162 288
940-174 278	941-182 265	942-183 250	943-176 234
944-166 223	945-158 213	946-149 205	947-141 199
948-134 193	949-126 190	950-122 189	951-119 185
952-115 185	953-113 184	954-112 182	955-110 182
956-109 181	957-109 181	958-111 181	959-114 181
960-116 180	961-118 180	962-121 179	963-124 180
964-129 180	965-132 180	966-138 181	967-143 181
968-150 182	969-158 182	970-167 182	971-175 183
972-184 183	973-192 184	974-207 183	975-236 187
976-236 187	977-259 191	978-281 194	979-304 198
980-341 208	981-372 252	982-343 339	983-305 342
984-274 346	985-251 352	986-235 357	987-223 356
988-213 356	989-205 357	990-193 357	991-192 2
992-188 360	993-184 360	994-182 360	995-180 360
996-178 1	997-177 1	998-177 2	999-177 360
1000-179 1	1001-182 1	1002-183 2	1003-187 2
1004-190 2	1005-194 1	1006-197 1	1007-203 2
1008-208 1	1009-215 360	1010-221 360	1011-229 356
1012-236 354	1013-244 352	1014-255 352	1015-264 345
1016-275 343	1017-289 336	1018-300 331	1019-313 323
1020-323 309	1021-329 303	1022-328 283	1023-322 268
1024-311 256	1025-303 250	1026-294 240	1027-281 232
1028-275 232	1029-270 232	1030-264 232	1031-259 230
1032-254 230	1033-253 229	1034-251 229	1035-250 228
1036-248 229	1037-250 224	1038-251 224	1039-251 225
1040-255 223	1041-257 222	1042-259 225	1043-264 223
1044-267 223	1045-272 223	1046-277 222	1047-285 217
1048-293 216	1049-306 217	1050-313 218	1051-326 211
1052-340 211	1053-354 203	1054-369 196	1055-383 189
1056-400 170	1057-400 140	1058-398 130	1059-381 117
1060-360 112	1061-344 103	1062-333 99	1063-321 96
1064-310 92	1065-295 89	1066-288 88	1067-278 86
1068-271 84	1069-265 85	1070-261 80	1071-256 81
1072-251 80	1073-248 81	1074-243 82	1075-241 80
1076-240 79	1077-238 78	1078-236 76	1079-235 75
1080-235 75	1081-238 72	1082-239 71	1083-242 70
1084-243 67	1085-243 65	1086-248 65	1087-249 61
1088-252 60	1089-255 61	1090-258 60	1091-263 57
1092-268 49	1093-272 47	1094-278 46	1095-281 44
1096-290 35	1097-293 27	1098-297 27	1099-302 17
1100-304 12	1101-306 10	1102-307 5	1103-307 349
1104-304 346	1105-298 338	1106-295 331	1107-291 320
1108-286 319	1109-282 313	1110-276 310	1111-273 303
1112-270 299	1113-264 294	1114-263 293	1115-259 292
1116-258 288	1117-254 282	1118-254 280	1119-253 276
1120-251 276	1121-254 275	1122-254 271	1123-253 268
1124-253 266	1125-256 260	1126-257 257	1127-258 254
1128-258 251	1129-259 248	1130-260 245	1131-260 239
1132-261 233	1133-261 228	1134-262 222	1135-262 216
1136-261 211	1137-260 204	1138-250 194	1139-257 186
1140-254 181	1141-252 178	1142-249 176	1143-247 171
1144-243 171	1145-238 167	1146-238 167	1147-237 164
1148-234 162	1149-231 161	1150-229 160	1151-228 155

1152-226	151	1153-224	148	1154-222	148	1155-222	149
1156-221	144	1157-222	145	1158-224	143	1159-224	140
1160-224	138	1161-224	138	1162-226	133	1163-227	132
1164-229	131	1165-231	127	1168-234	124	1167-236	123
1168-240	119	1169-243	111	1170-247	106	1171-250	107
1172-255	103	1173-260	98	1174-263	89	1175-267	87
1176-272	78	1177-270	72	1178-279	65	1179-282	61
1180-284	52	1181-285	43	1182-283	40	1183-279	34
1184-279	28	1185-275	22	1186-271	15	1187-270	9
1188-266	2	1189-263	357	1190-260	353	1191-258	347
1192-254	341	1193-250	339	1194-254	336	1195-251	330
1196-249	326	1197-248	326	1198-249	321	1199-248	319
1200-249	312	1201-249	311	1202-251	308	1203-251	306
1204-252	302	1205-253	298	1206-255	297	1207-257	294
1208-259	289	1209-261	288	1210-263	285	1211-266	281
1212-267	277	1213-269	272	1214-270	267	1215-271	263
1216-274	256	1217-274	251	1218-275	247	1219-276	237
1220-275	234	1221-276	229	1222-276	225	1223-275	223
1224-274	221	1225-273	219	1226-272	213	1227-275	211
1228-275	212	1229-277	212	1230-276	207	1231-277	207
1232-279	203	1233-283	200	1234-285	200	1235-286	200
1236-288	200	1237-291	198	1238-295	196	1239-297	197
1240-303	193	1241-308	191	1242-312	195	1243-317	194
1244-324	188	1245-327	188	1246-336	198	1247-344	187
1248-351	188	1249-363	191	1250-374	194	1251-397	192
1252-400	198	1253-400	201	1254-400	219	1255-400	226
1256-400	238	1257-400	247	1258-400	252	1259-400	261
1260-400	281	1261-400	282	1262-400	283	1263-400	284
1264-400	291	1265-400	295	1266-398	298	1267-394	296
1268-391	297	1269-396	287	1270-392	287	1271-389	286
1272-396	276	1273-398	272	1274-398	267	1275-400	259
1276-400	251	1277-400	246	1278-400	234	1279-400	229
1280-400	227	1281-397	215	1282-391	216	1283-385	211
1284-379	206	1285-373	201	1286-357	194	1287-352	194
1288-346	181	1289-340	176	1290-335	171	1291-329	166
1292-324	160	1293-321	160	1294-317	151	1295-313	143
1296-309	145	1297-309	141	1298-305	135	1299-302	133
1300-300	133	1301-298	131	1302-298	124	1303-296	124
1304-299	120	1305-298	114	1306-296	114	1307-294	112
1308-300	103	1309-300	99	1310-298	97	1311-297	94
1312-298	90	1313-299	87	1314-300	83	1315-298	81
1316-296	66	1317-296	63	1318-296	60	1319-296	56
1320-296	46	1321-293	41	1322-290	37	1323-287	32
1324-284	28	1325-281	23	1326-278	19	1327-275	15
1328-275	9	1329-274	5	1330-271	4	1331-271	360
1332-267	2	1333-267	357	1334-265	353	1335-264	354
1336-265	349	1337-263	344	1338-262	345	1339-262	347
1340-262	340	1341-263	336	1342-266	335	1343-265	332
1344-266	328	1345-268	328	1346-269	323	1347-270	320
1348-273	315	1349-274	313	1350-277	312	1351-279	307
1352-282	300	1353-285	296	1354-288	293	1355-291	291
1356-294	289	1357-297	285	1358-301	281	1359-304	277
1360-308	275	1361-312	269	1362-316	268	1363-321	265
1364-325	262	1365-330	259	1366-336	265	1367-344	262
1368-352	252	1369-357	252	1370-364	252	1371-375	242
1372-379	234	1373-378	234	1374-386	223	1375-386	214
1376-389	207	1377-389	203	1378-394	191	1379-398	184
1380-400	180	1381-400	184	1382-400	158	1383-400	154

1384-400	166	1385-400	147	1386-400	122	1387-400	119
1388-400	90	1389-400	69	1390-400	30	1391-400	35
1392-400	25	1393-400	16	1394-400	13	1395-400	13
1396-356	2	1397-379	356	1398-364	352	1399-358	344
1400-346	338	1401-341	334	1402-331	333	1403-323	328
1404-315	324	1405-311	325	1406-305	317	1407-299	310
1408-290	309	1409-288	304	1410-284	299	1411-283	298
1412-279	294	1413-278	289	1414-274	288	1415-275	288
1416-272	285	1417-269	282	1418-268	281	1419-265	278
1420-264	278	1421-263	271	1422-260	271	1423-259	272
1424-257	268	1425-256	267	1426-254	265	1427-253	261
1428-251	259	1429-251	257	1430-250	255	1431-249	249
1432-249	244	1433-247	241	1434-244	238	1435-244	235
1436-242	230	1437-241	226	1438-240	223	1439-239	215
1440-237	212	1441-237	207	1442-236	203	1443-234	203
1444-234	199	1445-233	193	1446-231	190	1447-231	183
1448-230	185	1449-230	181	1450-229	177	1451-228	174
1452-227	171	1453-226	167	1454-224	166	1455-224	167
1456-224	158	1457-225	152	1458-225	153	1459-224	153
1460-225	147	1461-226	145	1462-226	144	1463-227	144
1464-228	136	1465-229	130	1466-229	133	1467-230	131
1468-231	119	1469-232	119	1470-233	118	1471-236	110
1472-237	110	1473-239	106	1474-240	100	1475-241	98
1476-243	96	1477-245	93	1478-247	86	1479-249	84
1480-251	77	1481-253	76	1482-256	74	1483-259	70
1484-262	67	1485-264	59	1486-267	59	1487-268	59
1488-272	55	1489-274	52	1490-276	52	1491-278	46
1492-280	40	1493-282	40	1494-286	38	1495-289	31
1496-293	19	1497-298	24	1498-299	21	1499-308	4
1500-313	2	1501-318	356	1502-326	347	1503-333	347
1504-338	334	1505-346	326	1506-350	319	1507-353	322
1508-359	309	1509-360	301	1510-353	298	1511-354	286
1512-350	283	1513-342	281	1514-336	265	1515-332	252
1516-324	245	1517-317	243	1518-312	234	1519-305	217
1520-298	211	1521-290	210	1522-286	198	1523-279	198
1524-274	197	1525-272	190	1526-266	187	1527-260	187
1528-258	185	1529-255	178	1530-249	178	1531-246	176
1532-242	174	1533-239	172	1534-235	171	1535-232	169
1536-230	161	1537-227	157	1538-225	162	1539-223	164
1540-222	153	1541-220	143	1542-218	144	1543-216	145
1544-216	137	1545-213	135	1546-213	137	1547-211	131
1548-211	128	1549-209	129	1550-210	124	1551-209	119
1552-208	121	1553-206	122	1554-207	111	1555-207	108
1556-206	111	1557-205	109	1558-206	100	1559-207	100
1560-209	96	1561-209	93	1562-209	90	1563-209	87
1564-208	91	1565-210	91	1566-212	74	1567-210	82
1568-212	76	1569-211	73	1570-211	77	1571-214	67
1572-216	66	1573-216	68	1574-218	65	1575-219	61
1576-221	54	1577-222	57	1578-225	56	1579-227	52
1580-228	47	1581-230	50	1582-233	44	1583-234	42
1584-237	43	1585-240	37	1586-243	31	1587-246	31
1588-250	30	1589-257	19	1590-260	16	1591-263	16
1592-270	13	1593-274	3	1594-280	360	1595-288	1
1596-295	351	1597-302	348	1598-311	349	1599-319	342
1600-333	336	1601-344	335	1602-355	330	1603-367	316
1604-374	309	1605-373	299	1606-372	287	1607-357	265
1608-342	243	1609-333	228	1610-319	215	1611-306	212
1612-290	204	1613-281	198	1614-269	193	1615-260	192

1616-249	192	1617-242	180	1618-234	185	1619-228	182
1620-222	179	1621-216	173	1622-210	173	1623-206	177
1624-201	171	1625-197	170	1626-192	168	1627-187	168
1628-183	164	1629-180	162	1630-176	161	1631-173	161
1632-171	154	1633-167	154	1634-165	157	1635-162	150
1636-160	147	1637-157	150	1638-156	145	1639-153	144
1640-151	144	1641-149	146	1642-148	140	1643-146	137
1644-144	138	1645-143	138	1646-143	131	1647-141	127
1648-140	131	1649-139	137	1650-139	124	1651-137	122
1652-136	124	1653-137	120	1654-137	119	1655-137	120
1656-137	115	1657-136	114	1658-135	115	1659-135	112
1660-136	109	1661-136	106	1662-138	108	1663-140	110
1664-140	106	1665-141	102	1666-142	101	1667-143	101
1668-145	99	1669-146	98	1670-148	98	1671-149	92
1672-151	90	1673-152	90	1674-155	89	1675-157	88
1676-160	86	1677-163	84	1678-166	83	1679-169	81
1680-173	81	1681-177	78	1682-181	72	1683-185	72
1684-190	72	1685-196	68	1686-202	63	1687-208	63
1688-215	57	1689-222	52	1690-230	49	1691-239	45
1692-249	38	1693-257	21	1694-266	12	1695-272	357
1696-275	347	1697-271	337	1698-281	329	1699-253	321
1700-291	313	1701-230	305	1702-218	299	1703-208	295
1704-195	289	1705-189	282	1706-180	280	1707-171	277
1708-163	273	1709-157	271	1710-150	266	1711-143	265
1712-137	266	1713-132	264	1714-126	259	1715-121	258
1716-115	255	1717-110	255	1718-105	253	1719-101	251
1720-97	250	1721-93	249	1722-88	244	1723-85	244
1724-79	243	1725-75	243	1726-72	242	1727-69	241
1728-66	240	1729-63	238	1730-59	237	1731-56	236
1732-53	235	1733-50	233	1734-48	232	1735-44	232
1736-41	231	1737-39	229	1738-36	228	1739-34	227
1740-32	228	1741-28	227	1742-26	225	1743-24	225
1744-21	225	1745-19	225	1746-17	224	1747-15	224
1748-13	223	1749-11	222	1750-10	222	1751-8	224
1752-5	219	1753-3	220	1754-2	222	1755-1	216
1756-0	215	1757-2	217	1758-4	217	1759-5	217
1760-8	217	1761-8	218	1762-9	214	1763-12	220
1764-12	222	1765-13	218	1766-14	211	1767-15	212
1768-17	216	1769-18	216	1770-18	212	1771-20	212
1772-21	215	1773-22	212	1774-23	211	1775-24	215
1776-25	209	1777-26	208	1778-27	211	1779-28	212
1780-29	208	1781-29	208	1782-30	212	1783-30	211
1784-31	206	1785-32	206	1786-33	210	1787-33	208
1788-34	207	1789-35	206	1790-35	208	1791-34	208
1792-34	206	1793-35	207	1794-36	204	1795-36	206
1796-37	209	1797-37	204	1798-37	203	1799-38	205

MATCHED FILTER  
PROGRAM AG2  
TABLE OF CONTENTS

<u>Section</u>		<u>Page</u>
1	GENERAL	139
2	ABSTRACT	139
3	MACHINE DEFINITION	139
4	PROGRAM DESCRIPTION	141
5	INSTRUCTIONS TO CUSTOMER	141
	5.1 Input Data	141
	5.2 Output Data	143
	5.3 Time Estimate	146
6	AG2 FORTRAN IV LISTING	147
7	FLOW CHART DIAGRAM	
8	SAMPLE PROBLEM	152
	8.1 Description	152
	8.2 Input Data	152
	8.3 Output Data	154

MATCHED FILTER  
PROGRAM AG2  
DOCUMENTATION

1. GENERAL

This exhibit is a documentation of Electronic Data Processing (EDP) Program AG2, Matched Filter Program, produced under contract AF30(602)-67-C-007 for RADC by the Fort Worth Division of General Dynamics. EDP program AG2 was originally written for use with an IBM 360 system; however, in this documentation the necessary changes have been incorporated to make the program compatible with the GE625/635 computer at RADC. This documentation has been prepared in accordance with Electronic Data Processing (EDP) Programs and Program Documentation, Requirements for Preparation of, Exhibit RADC-3010 of 17 January 1964.

2. ABSTRACT

The purpose of this procedure is the computation of a set of correlation coefficients  $\rho(D, \theta)$  the magnitude of which are an indication of the probability that a scattering center is located at the polar coordinates  $(D, \theta)$ . The library data processed by this procedure consists of cross section and absolute phase data obtained from magnetic tapes produced by procedure A24. The output of AF2 is a listing of the magnitudes of  $\rho(D, \theta)$  as a function of discrete values of  $D$  and  $\theta$ . Any portion of the library data can be selected as input by adjusting the problem data.

3. MACHINE DEFINITION

The program was originally written for use with an IBM 360 computer system. The enclosed documentation is in Fortran IV language and is

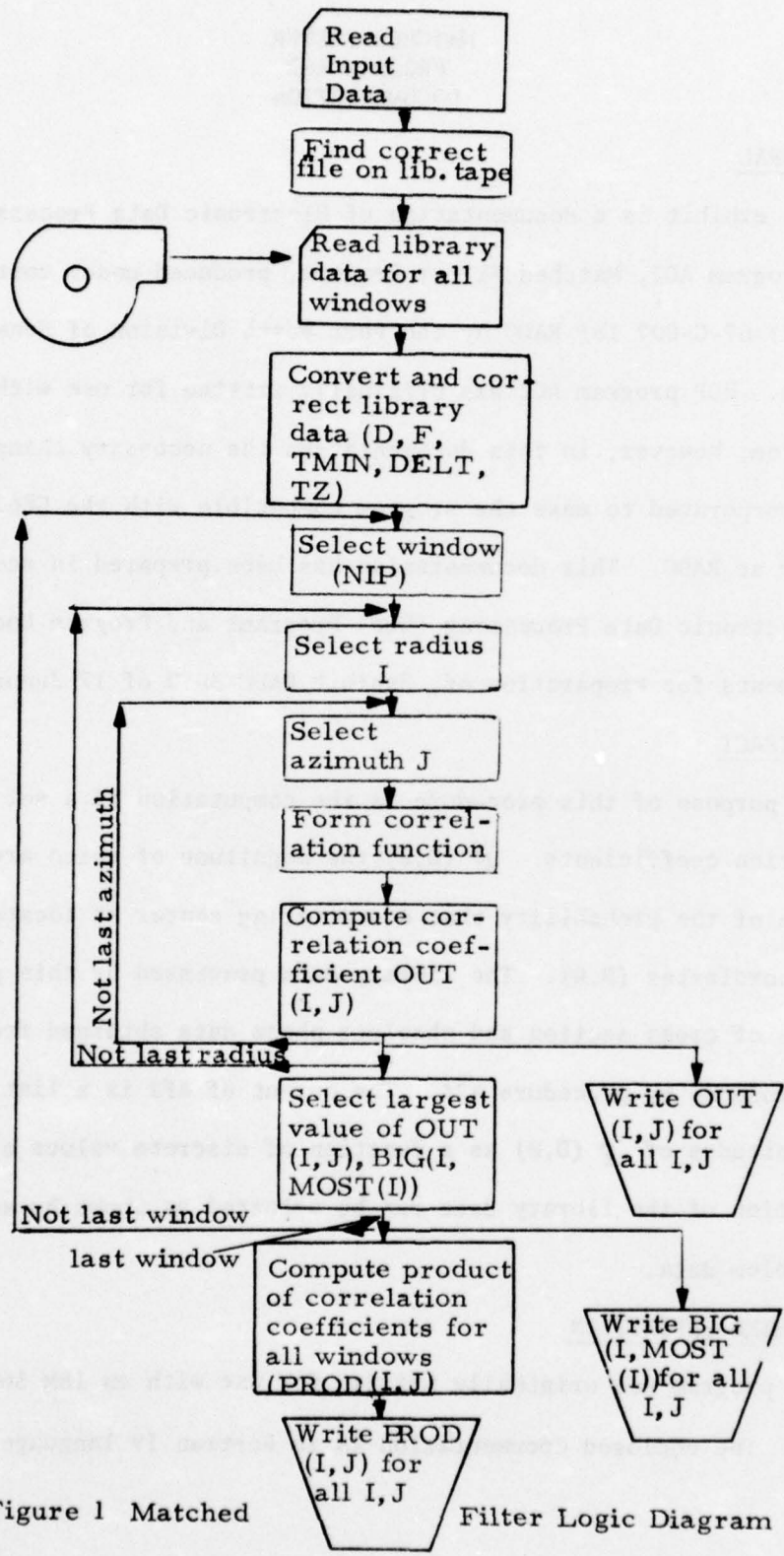

Figure 1 Matched

Filter Logic Diagram

specifically designed for use with the GD625/635 computer at RADC.

#### 4. PROGRAM DESCRIPTION

Figure 1 contains a simplified logic diagram of AG2. Basically the program performs the following functions:

1. Calls the problem
2. Selects the correct file on the library tape
3. Reads the library data for all windows
4. Computes the correlation coefficients for all windows
5. Computes the product of the correlation coefficients for

selected windows.

#### 5. INSTRUCTIONS TO CUSTOMER

##### 5.1 Input Data

1. Library Data. Library tapes for procedure AG2 are produced by procedure A24. These tapes are identified by a label of the form XXXXXXANN where XXXXXX is the job number under which the tape is produced, A is an alphabetic character, and NN is a sequence number.

##### 2. Problem Data

###### a. Identification Format

###### Columns

63-68	Job Number
69	"p"
70-72	Deck number
73-77	Card sequence number
78-80	AG2

b. Input Parameters

F	Frequency (GHz)
TMIN	Initial target aspect angle
DELT	Target aspect angle increment
L	No of input aspect angles (Total encompassed by all windows)
PHIM	Minimum output geometry angle
DELP	Output geometry angle
N	No of output geometry angles (az)
YMIN	Minimum dimension parameter
M	No of output dimension parameters (radians)
DELY	Dimension parameter increment
MI(KK)	Minimum aspect for <u>KKth</u> interval
MA(KK)	Maximum aspect for <u>KKth</u> interval
NIP	No of aspect windows
D	Residual radius arm in input phase data
TZ	Angle formed by D
NR	No of files to be processed
ISTEP	Correlation increment = 1,2,5,10 or 20 only
NFILE	No of files on tape
IFD	Field on library tape where first aspect angle is located
IFN	File number being processed

c. Card Formats (AG2)

(i) First card of each problem deck

Card	
Cols	1-4
Data	NR

(ii) Second card of each problem deck

Card								
Cols	1-10	11-20	21-30	31-40	41-50	51-60	61-64	65-66
Data	L	M	N	TMIN	YMIN	PHIM	N FILE	IFD

(iii) Third card of each problem deck

Card									
Cols	1-10	11-20	21-30	31-40	41-50	51-60	61-62	63-64	65-66
Data	F	DELT	DELY	DELP	D	TZ	IFN	NIP	ISTEP

All input items except those beginning with the letters I,J,K, L,M or N must contain a decimal point and may contain an exponent (power of ten by which the number is multiplied) in the right most columns of its field. The exponent may be omitted if the last column of the field is blank. When input the exponent is preceded by its sign or the character E and contains no decimal point. Items beginning with the letters I, J, K, L, M or N must be right adjusted to their respective fields.

5.2 Output Data

1. Output Parameters

The output of this procedure is a listing of the magnitude of the following quantities:

OUT (I,J)	Correlation coefficient for single windows where I corresponds to radius and J to azimuth of the computer scattering center.
-----------	--

BIG(I,J)            Maximum values of OUT(I,J) for each I  
                          occurring when J = MOST(I)

PROD(I,J)           Normalized Product of values of OUT(I,J)  
                          for each window.

The location R (radius in inches) of a scattering center is computed from the value of I using the equation

$$R = YMIN + (I-1) * DELY$$

The azimuth angle of a scattering center is computed using the equation

$$PHAS (J) = PHIM + (J-1) * DELP$$

## 2. Output Format

(i) Window #1

(A1)    I                    BIG (I,MOST(I))            MOST(I)

         continue for I=1,M

(A2)    I=1                     $\ddots$   
                                   OUT(1,J) for J=1,N

         I=2                    OUT(2,J) for J=1,N

$\ddots$   
          continue for I=1,M

(A3)    I=1                    PROD(1,J) for J=1,N

         I=2                    PROD(2,J) for J=1,N

         continue for I=1,M

NOTE: In this case only PROD(I,J) = OUT(I,J) since  
          only one window is used.

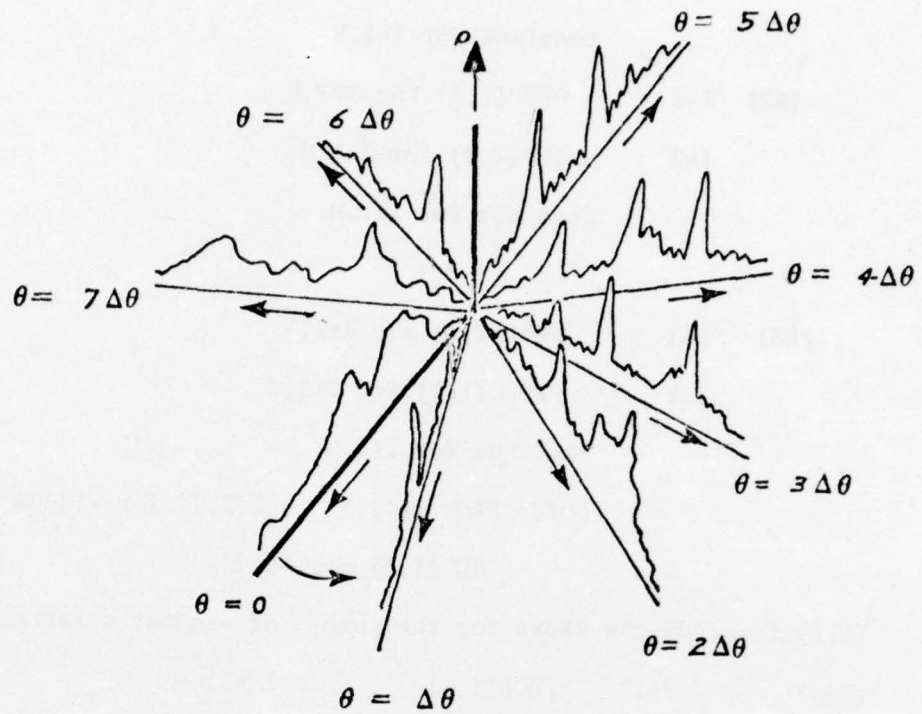

Fig. 2 Polar Plot of  $(R, \theta)$  for Discrete Values of  $\theta$

(ii) Window #2

(A1) I            BIG (I,MOST(I))            MOST(I)

                 continue for I=1,M

(A2) I-1            OUT (1,J) for J=1,N

                 I=2            OUT(2,J) for J=1,N

                 continue for I=1,M

                 ...

(A3) I=1            PROD(1,J) for J=1,N

                 I=2            PROD (1,J) for J=1,N

                 continue for I=1,M

NOTE: PROD(I,J) = OUT(I,J) for window 1    \*

                 OUT(I,J) for window 2

(iii) Continue the above for the number of windows selected.

(iv)            J=1            PROD(I,1)            I = 1,M

                 J=2            PROD(I,2)            I=1,M

                 Continue for J=1,N

The last two lists of PROD(I,J) represent identical data; however, the first is an azimuth cut and the second is a cut along a given radius. Figure 2 shows typical values of plotted in polar coordinates.

5.3 Time Estimate. Approximately 3 minutes are required to run one problem using four windows of 20° each.

```

C      MATCHED FILTER PROGRAM
      DIMENSION SIGR(3600), SIGM(3600), SIGP(3600), OUT(100,180), IGM(3600),
      1 IGP(3600), BIG(200), MOST(100), IDOU(3) ,
      2 MI(20), MA(20), KZ(3600), PHAS(360), PRO(100,180)
      1 IIFN = 0
      CALL FLGEOF( 6 , IEOF)
      IIFN = 0
      READ (5,300) NR
      300 FORMAT (I4)
      DO 60 NF=1,NR
      WRITE (6,2)
      2 FORMAT(19H1 INPUT DATA VALUES)
      READ (5,3) L,M,N,TMIN,YMIN,PHIM,NFILE,IFD
      3 FORMAT (3I10,3F10,3,I4,I2)
      READ (5,301) F,DELT,DELY,DELP,D,TZ,IFN,NIP,ISTEP
      301 FORMAT (6F10,3,3I2)
      DELPD = DELP
      IFILE = IFN
      DO 4000 I=1,M
      DO 4000 J=1,N
      4 00 PRO(I,J) = 1.0
      DO 302 KK=1,NIP
      302 READ (5,303) MI(KK), MA(KK)
      303 FORMAT (2I5)
      WRITE (6,3) L,M,N,TMIN,YMIN,PHIM,NFILE,IFD
      WRITE (6,301) F,DELT,DELY,DELP,D,TZ,IFN,NIP,ISTEP
      WRITE (6,300) NR
      DO 304 KK=1,NIP
      304 WRITE (6,303) MI(KK), MA(KK)
      IF (ISTEP, EQ.1) GO TO 700
      IF (ISTEP, EQ.2) GO TO 700
      IF (ISTEP, EQ.5) GO TO 700
      IF (ISTEP, EQ.10) GO TO 700
      IF (ISTEP, EQ.20) GO TO 700
      WRITE (6,701) ISTEP
      701 FORMAT (21H THE VALUE OF ISTEP, ,I2,26H, IS NOT ACCEPTABLE TO AG2
      D)
      GO TO 60
      700 IFN = IFN - IIFN
      XXIFN = IFN - 1
      NSKIP = (TMIN + 180.0)/0.1 + 903.*XXIFN + 2.
      FREQ = (2.*3.14159*F*10.**9)/3.0E+8
      RPD = 3.14159/180.0
      TMIN = TMIN*RPD
      PHIM = PHIM*RPD
      DELT = DELT*RPD
      DELP = DELP*RPD
      YMIN = 0.0254*YMIN
      DELY = 0.0254*DELY
      D = 0.0254*D
      TZ = TZ*RPD
      KTE = 1

```

```

IF(IFILE .EQ. IIFN)GO TO 33
  DO 8 K = 1,NSKIP
  READ(8,4)
  IF(IEOF .EQ. 0)GO TO 8
4  FORMAT(1X)
  IEOF = 0
8  CONTINUE
  KTE = 1
  JZ = 1
  IF (IFD.EQ.1) GO TO 12
  IF (IFD.NE.2) GO TO 601
  JZ = 4
  READ (8,600) IGM(1),IGP(1),IGM(2),IGP(2), IGM(3),IGP(3),IDOU
600 FORMAT (14X,6X,2I4,6X,2I4,6X,2I4,6X,I6,1HP,I3,I5,3HA24)
  WRITE (6,600) IGM(1),IGP(1),IGM(2),IGP(2),IGM(3),IGP(3),IDOU
  GO TO 12
601 IF (IFD.NE.3) GO TO 603
  JZ = 3
  READ (8,602) IGM(1),IGP(1),IGM(2), IGP(2),IDOU
602 FORMAT (28X,6X,2I4,6X,2I4,6X,I6,1HP,I3,I5,3HA24)
  WRITE (6,602) IGM(1),IGP(1),IGM(2),IGP(2),IDOU
  GO TO 12
603 IF (IFD.NE.4) GO TO 12
  JZ = 2
  READ (8,604) IGM(1),IGP(1),IDOU
604 FORMAT (42X,6X,2I4,6X,I6,1HP,I3,I5,3HA24)
  WRITE (6,604) IGM(1),IGP(1),IDOU
  12 JZZ = JZ+1
  DO 32 K=JZ,JZZ,4
  READ (8,13) IGM(K),IGP(K),IGM(K+1),IGP(K+1),IGM(K+2)
D,IGP(K+2),IGM(K+3),IGP(K+3),IDOU
  IF(IEOF .EQ. 0)GO TO 1333
  IEOF = 0
  GO TO 14
  13 FORMAT (6X,2I4,6X,2I4,6X,2I4,6X,2I4,6X,I6,1HP,I3,I5,3HA24)
1333 IF (KTE .GT. 10) GO TO 16
  WRITE (6,13) IGM(K),IGP(K),IGM(K+1),IGP(K+1),IGM(K+2),IGP(K+2),
D IGM(K+3),IGP(K+3),IDOU
  GO TO 16
  14 IF (KTE.GT.10) GO TO 16
  WRITE (6,15) IGM(K),IGP(K),IGM(K+1),IGP(K+1),IGM(K+2),IGP(K+2),
D IGM(K+3),IGP(K+3),IDOU
  15 FORMAT(1X,8HERROR 08/6X,2I4,6X,2I4,6X,2I4,6X,2I4,6X,I6,1HP,I3,I5,
D 3HA24)
  16 KTE = KTE+1
  32 CONTINUE
  33 KZ(1) = 0
  KZZ = 1
  54 DO 148 K=1,L,ISTEP
  SIGP(KZZ)=FLOAT(IGP(K))*RFD
  EXP = (FLOAT(IGM(K)))/200.0
  VALUE = 10.0**EXP

```

```

      XXXK = K-1
      SIGP(KZZ) = SIGP(KZZ)+2.0*D*FREQ*COS(TMIN+ XXXK *DELT + TZ)
      SIGR(KZZ)=VALUE * COS(SIGP(KZZ))
      SIGM(KZZ)=VALUE * SIN(SIGP(KZZ))
148 KZZ = R + ISTEP - ((KZZ)*(ISTEP-1))
      DO 161 IP = 1,NIP
      MIN = (TMIN/RPD)*10.0
      KXX1 = ( MI(IP)- MIN)/ISTEP+1
      KXX2 = ( MA(IP)- MIN)/ISTEP+1
      DO 150 I = 1,M
      XXXI = I -1
      B = 2.0*FREQ*(YMIN + XXXI * DELY)
      DO 150 J =1,N
      XXXJ = J -1
      PHI = PHIM + XXXJ * DELP
      PHAS(J) = -(PHIM + XXXJ * DELPD) + 180.
      IF (PHAS(J).LT.0.) PHAS(J) = PHAS(J) + 36.
      SUM1 = 0.0
      SUM2 = 0.0
      DO 149 K=KXX1,KXX2
      XXXK = K -1
      XISTEP = ISTEP
      ARG = COS( TMIN + XXXK*XISTEP *DELT + PHI)
      FILTR = COS(B*ARG)
      FILTI = SIN(B*ARG)
      SUM1 = SUM1 + SIGR(K)*FILTR + SIGM(K)*FILTI
149 SUM2 = SUM2 + SIGM(K)*FILTR - SIGR(K)*FILTI
      OUT(I,J) = SQRT(SUM1**2 + SUM2 **2)
      PRO(I,J) = OUT(I,J) * PRO(I,J)
150 CONTINUE
      DO 151 I=1,M
      BIG(I) = OUT(I, 1)
      MOST(I) = 1
      DO 151 J=2,N
      IF ( OUT(I,J).LE.BIG(I)) GO TO 151
      BIG(I) = OUT(I,J)
      MOST(I) = PHAS(J)
151 CONTINUE
      FXX1 = FLOAT(MI(IP))/10.0
      FXX2 = FLOAT(MA(IP))/10.0
      WRITE (6,153) IP,FXX1,FXX2
153 FORMAT (10H WINDOW ,I4,10X,F7.3,2X,2HTO,2X,F7.3)
      WRITE (6,154) (I,BIG(I),MOST(I),I=1,M)
154 FORMAT (1H0,13HMAX AND MIN VALUES/, (I4,1E20.7,1B))
      DO 159 I = 1,M
      WRITE (6,155) I, (OUT(I,J), PHAS(J),J=1,N)
155 FORMAT (1H0,2HI=,I3,/, (5(E13.7,2X,F4.0,2X)))
159 CONTINUE
      WRITE (6,932) IP
932 FORMAT (1H0,35HTHE FOLLOWING ARRAY IS PRO(I,J) FOR,IS, 7HWINDOWS)
      DO 1161 I =1,M
      WRITE (6,155) I, (PRO(I,J), PHAS(J),J=1,N)

```

MATCHED FILTER PROGRAM

```
1161 CONTINUE
    IF(IP .NE. NIP)GO TO 161
    DO 1162 J = 1,N
1162 WRITE(6,1155) PHAS(J), (PRO(I,J), I = 1,M)
1155 FORMAT (1H0,8HPHAS(J)=,F4.0,/,10(3X,E10.4))
161 CONTINUE
    IF(IFILE .EQ. IIFN)GO TO 58
    DO 16 IAC=1,903
160 READ(8, 4)
    IF(IEOF .EQ. 1)IEOF = 0
58 IIFN = IFILE
60 CONTINUE
    GO TO 1
END
```

1	1							
2	505	17	90	10.0	0.0	0.0	18	1
STATEMENT LABEL MUST BE BETWEEN 1 AND 99999								
. IS ILLEGAL AS THE FIRST CHARACTER OF A STATEMENT								
3	5.975	0.10	1.0	4.0	0.0	0.0	1	310
4	100	300						
STATEMENT LABEL MUST BE BETWEEN 1 AND 99999								
5	250	450						
STATEMENT LABEL MUST BE BETWEEN 1 AND 99999								
6	400	600						
STATEMENT LABEL MUST BE BETWEEN 1 AND 99999								
'STOP' STATEMENT IS MISSING-SIMULATED								
'END' STATEMENT MISSING-SIMULATED								

## 8. SAMPLE PROBLEMS

8.1 Description. A sample problem is included for checking out program AG2.

8.2. Input Data. The input data used for the sample problem is shown on the following page. Any portion of the library data can be selected as input by adjusting the problem data. The input data is explained in Section 5.1.

4	3405	27	90	-170.0	0.0	0.0 12 1
	5.95	0.10	1.0	4.0	0.0	0.0 2 410
700-1500						
-1550-1350						
-1400-1200						
-1250-1050						
	3405	27	90	-170.0	0.0	0.0 12 1
	5.95	0.10	1.0	4.0	0.0	0.0 2 410
-750 -550						
-600 -400						
-450 -250						
-300 -100						
	3405	27	90	-170.0	0.0	0.0 12 1
	5.95	0.10	1.0	4.0	0.0	0.0 2 410
100 200						
250 450						
400 600						
550 750						
	3405	27	90	-170.0	0.0	0.0 12 1
	5.95	0.10	1.0	4.0	0.0	0.0 2 410
1050 1250						
1200 1400						
1350 1550						
1500 1700						

/\*

CC = 0026

8.3 Output Data. The output from Procedure AG2 for the sample problem is given on the following pages.

*[Faint, illegible text, likely bleed-through from the reverse side of the page]*

INPUT DATA VALUES

3405	27	90	-170.000	0.0	0.0	12 1
5.950	0.100	1.000	4.000	0.0	0.0	2 410
4						
-750	-550					
-600	-400					
-450	-250					
-300	-100					
WINDOW	1		-75.000 TO -55.000			

MAX AND MIN VALUES

1	0.2154750E 01	1
2	0.2161719E 01	112
3	0.2167113E 01	112
4	0.2170906E 01	112
5	0.2173096E 01	112
6	0.2173677E 01	112
7	0.2172664E 01	112
8	0.2170066E 01	112
9	0.2165906E 01	112
10	0.2160215E 01	112
11	0.2153029E 01	112
12	0.2144399E 01	112
13	0.2134377E 01	112
14	0.2123020E 01	112
15	0.2110391E 01	112
16	0.2096560E 01	112
17	0.2081605E 01	112
18	0.2065608E 01	112
19	0.2048652E 01	112
20	0.2030815E 01	112
21	0.2012197E 01	112
22	0.1992885E 01	112
23	0.1972970E 01	112
24	0.1952545E 01	112
25	0.1931688E 01	112
26	0.1910500E 01	112
27	0.1889054E 01	112

I = 1

.2154750E 01	180.	0.2154750E 01	176.	0.2154750E 01	172.
.2154750E 01	160.	0.2154750E 01	156.	0.2154750E 01	152.
.2154750E 01	140.	0.2154750E 01	136.	0.2154750E 01	132.
.2154750E 01	120.	0.2154750E 01	116.	0.2154750E 01	112.
.2154750E 01	100.	0.2154750E 01	96.	0.2154750E 01	92.

0.2154750E 01 168. 0.2154750E 01 164.  
0.2154750E 01 148. 0.2154750E 01 144.  
0.2154750E 01 128. 0.2154750E 01 124.  
0.2154750E 01 108. 0.2154750E 01 104.  
0.2154750E 01 88. 0.2154750E 01 84.

PHAS(J)=212.				
0.3096E-02	0.5463E-02	0.1625E-02	0.1597E-01	0.6373E-00
0.1787E-01	0.8073E-02	0.2897E-02	0.5987E-02	0.4872E-03
0.3985E-03	0.4592E-03	0.2001E-03	0.2512E-03	0.2764E-03
PHAS(J)=208.				
0.3096E-02	0.5407E-02	0.1718E-02	0.2088E-01	0.6112E-00
0.5215E-01	0.1049E-01	0.1148E-02	0.6305E-02	0.3722E-03
0.3418E-03	0.9716E-03	0.1990E-03	0.1264E-03	0.4493E-03
PHAS(J)=204.				
0.3096E-02	0.5348E-02	0.1836E-02	0.2724E-01	0.6060E-00
0.5340E-01	0.6025E-02	0.1531E-02	0.2288E-02	0.5444E-03
0.3144E-03	0.5120E-03	0.2611E-03	0.2166E-03	0.3212E-03
PHAS(J)=200.				
0.3096E-02	0.5285E-02	0.1976E-02	0.3523E-01	0.6831E-00
0.1808E-01	0.8059E-02	0.4257E-02	0.9291E-02	0.3199E-03
0.6067E-03	0.7395E-03	0.1672E-03	0.1688E-03	0.3117E-03
PHAS(J)=196.				
0.3096E-02	0.5213E-02	0.2137E-02	0.4498E-01	0.1001E-01
0.1510E-00	0.3819E-02	0.3142E-02	0.8690E-02	0.3636E-02
0.1007E-03	0.6538E-03	0.6502E-03	0.4007E-03	0.7576E-04
PHAS(J)=192.				
0.3096E-02	0.5127E-02	0.2313E-02	0.5649E-01	0.1687E-01
0.3810E-00	0.5823E-01	0.2412E-02	0.1625E-02	0.7145E-02
0.4550E-04	0.2609E-03	0.1342E-03	0.3411E-03	0.7958E-03
PHAS(J)=188.				
0.3096E-02	0.5025E-02	0.2499E-02	0.6967E-01	0.2757E-01
0.8508E-00	0.1332E-01	0.2329E-01	0.4096E-02	0.2030E-02
0.1189E-03	0.3858E-03	0.3440E-03	0.1647E-03	0.1616E-03
PHAS(J)=184.				
0.3096E-02	0.4903E-02	0.2684E-02	0.8428E-01	0.4156E-01
0.1136E-01	0.2186E-01	0.2370E-01	0.5745E-01	0.3771E-02
0.4158E-03	0.6100E-04	0.2192E-03	0.1229E-03	0.1977E-03

0.4210E 00	0.2688E 00	0.1257E 01	0.4293E 00	0.1355E 00
0.2854E-03	0.5643E-03	0.2423E-04	0.3580E-03	0.6101E-03
0.9219E-04	0.5578E-03			
0.4435E 00	0.1547E 00	0.1421E 01	0.1001E 01	0.4576E-01
0.8961E-03	0.3545E-03	0.3134E-06	0.6135E-03	0.2709E-03
0.1189E-03	0.4067E-03			
0.4624E 00	0.8211E-01	0.1336E 01	0.1678E 01	0.1775E 00
0.8896E-03	0.1093E-02	0.2787E-05	0.2366E-03	0.5506E-03
0.1350E-03	0.2604E-03			
0.5011E 00	0.1362E 00	0.9683E 00	0.2213E 01	0.6159E 00
0.2990E-03	0.1702E-02	0.5947E-04	0.8835E-05	0.2658E-03
0.3160E-03	0.2556E-03			
0.5914E 00	0.1902E 00	0.4421E 00	0.2252E 01	0.1296E 01
0.4040E-03	0.1412E-03	0.2705E-03	0.3098E-03	0.3281E-04
0.7939E-04	0.8853E-03			
0.7324E 00	0.2352E 00	0.1221E 00	0.1605E 01	0.1911E 01
0.4107E-02	0.1146E-02	0.6600E-05	0.6569E-03	0.2206E-03
0.1106E-03	0.1520E-03			
0.9119E 00	0.3321E 00	0.3048E 00	0.5973E 00	0.1848E 01
0.3214E-02	0.5870E-02	0.1907E-02	0.1706E-03	0.6675E-04
0.2857E-03	0.1196E-03			
0.1315E 01	0.5127E 00	0.4649E 00	0.2407E 00	0.9534E 00
0.3229E-03	0.5269E-02	0.3929E-02	0.1272E-02	0.2233E-02
0.1067E-02	0.4019E-03			

## SECTION VI

POLARIZATION SIGNATURE TECHNIQUE  
PROGRAM AG3

## TABLE OF CONTENTS

<u>SECTION</u>	<u>TITLE</u>	<u>PAGE</u>
1	GENERAL	160
2	ABSTRACT	160
3	MACHINE DEFINITION	160
4	PROGRAM DESCRIPTION	160
	4.1 Main Program	160
	4.2 Subroutine PLTPOL	161
	4.3 Subroutine PLTPHA	161
	4.4 Subroutine SKIPF	161
	4.5 Subroutine PHASE	161
	4.6 Subroutine ERROR	161
5	INSTRUCTIONS TO CUSTOMER	161
	5.1 Input Data	161
	5.2 Output Data	166
	5.3 Time Estimate	166
6	AG3 FORTRAN IV LISTING	167
7	FLOW CHART DIAGRAM	
8	SAMPLE PROBLEM	179
	8.1 Description	179
	8.2 Input Data	179
	8.3 Output Data	180

POLARIZATION SIGNATURE TECHNIQUE  
PROGRAM AG 3  
DOCUMENTATION

1. GENERAL

This exhibit is a documentation of Electronic Data Processing (EDP) Program AG3, Polarization Signature Technique Program, produced under contract AF30(602)-67-C-0074 for RADC by the Fort Worth division of General Dynamics. EDP program AG3 was originally written for use with an IBM 360 system; however, in this documentation the necessary changes have been incorporated to make the program compatible with the GE 625/635 computer at RADC. This documentation has been prepared in accordance with Electronic Data Processing (EDP) Programs and Program Documentations, Requirements for Preparation of, Exhibit RADC-3010 of 17 January 1964.

2. ABSTRACT

The purpose of this procedure is the computation of average polarization signature ratios  $RHOH1$  and  $RHOHQ$  and the computation of the absolute location in space of the phase centers of a vehicle. The library data processed by this procedure consists of target scattering matrix data obtained from magnetic tapes produced by procedure A81. The output of AG3 is a listing of the magnitudes of  $RHOL1$  and  $RHOL2$  and a plot of  $RHOH1$  and  $RHOH2$  as a function of the target aspect angle and a plot of the absolute phase of a vehicle as a function of aspect angle. The computation of the absolute location of the phase center is a subroutine of the polarization signature program.

3. MACHINE DEFINITION

The program was originally written for use with an IBM 360 computer system. The enclosed documentation is in Fortran IV language and is specifically designed for use with the GE 625/635 computer and the EAI plotter at RADC. A magnetic tape is produced by the GE 625/635 and is then run on the EAI plotter to produce a plot.

4. PROGRAM DESCRIPTION

Program AG3 is divided into a main program and five subroutines: PLTPOL, PLTPHA, SKIPF, PHASE and ERROR. These divisions are described below.

4.1. Main Program. The main program performs the following functions:

1. Calls the problem
2. Reads the library data for the target scattering matrix

3. Computes the radar cross section at a set of selected polarizations (P) and forms the ratio:

$$\text{Ratio} = \frac{|\sigma(e, \theta) - \sigma(e + \pi/2, \theta)|}{|\sigma(e, \theta) + \sigma(e + \pi/2, \theta)|}$$

4. Selects the polarizations RHOH1 and RHOH2 between which the ratio is greater than a prescribed threshold level

5. Averages the volume of RHOL1 and RHOL2 over a set of NN aspect angles to produce averages RHOH1 and RHOH2

Figure 1 contains a logic diagram of the main program.

4.2 Subroutine PLTPOL. This subroutine is used to plot RHOH1 and RHOH2 as a function of aspect angle. GE 635 subroutines LINE, NUMBER and STDBY are called in this subroutine.

4.3 Subroutine PLTPHA. This subroutine is used to plot the absolute phase in radians vs aspect angle. GE 635 subroutines LINE, NUMBER and STDBY are called in this subroutine.

4.4 Subroutine SKIPF. This subroutine is used to select the correct file on the library input tape.

4.5 Subroutine PHASE. This subroutine computes the absolute location in space of the phase center of a vehicle. Figure 2 shows a logic diagram of this subroutine.

4.6 Subroutine ERROR. This subroutine is used to print out error messages.

## 5. INSTRUCTIONS TO CUSTOMER

### 5.1 Input Data

1. Library Data. Library tapes for procedure AG3 are produced by procedure A81. These tapes contain scattering matrix data - one matrix per cord image - in cord image form. Each target file (not a tape file) contains six identification records and 3,600 data records.

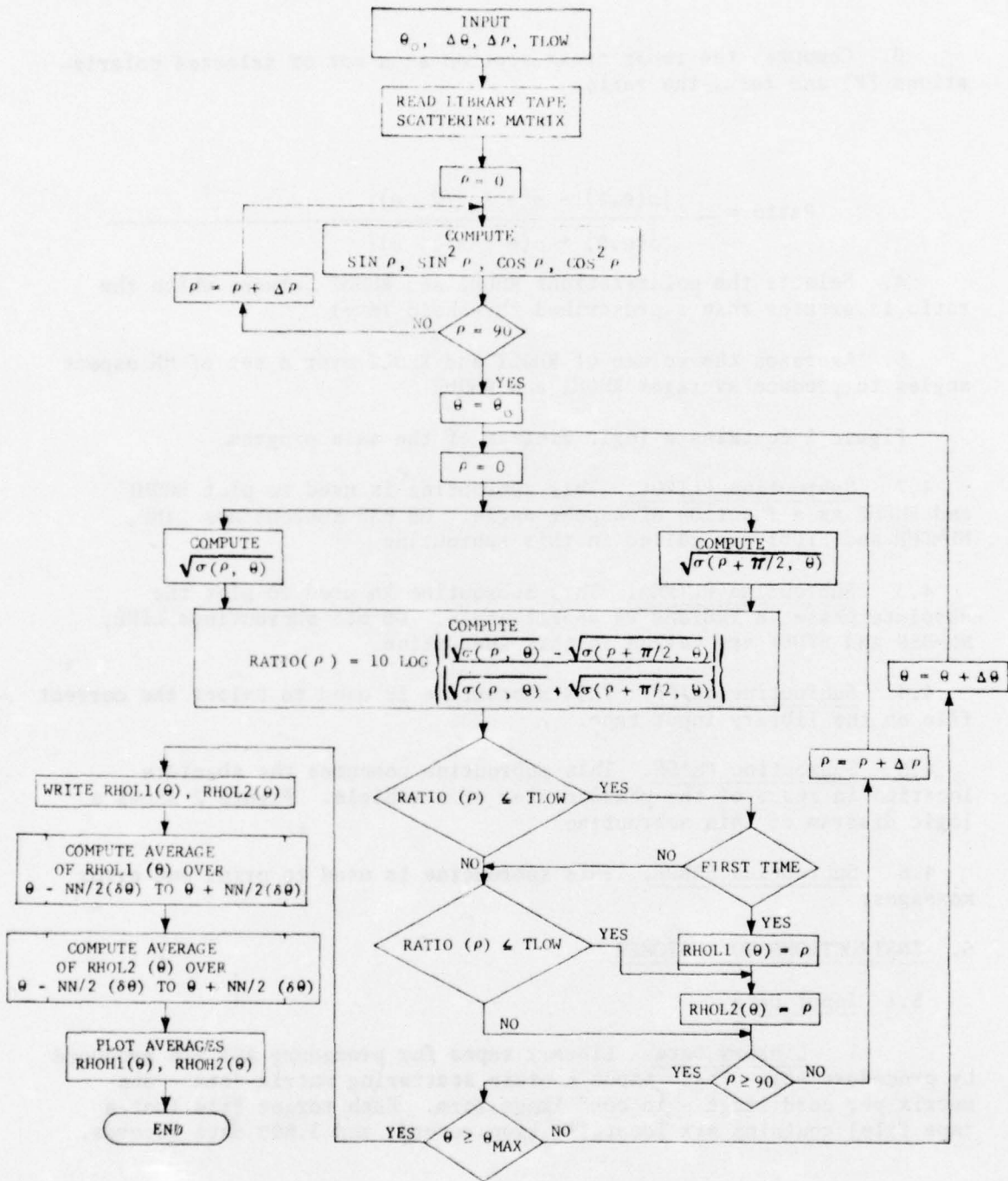

Fig. 1 LOGIC DIAGRAM OF PROGRAM AG

## 2. Problem Data

### a. Identification Format

#### Columns

63 - 68	Job number
69	"p"
70 - 72	Deck number
73 - 77	Cord sequence number
78 - 80	AG3

### b. Input Parameters

NN	Number of aspect angles over which RHOH is overaged
IOP1	= 0 If VH equal 0 = 1 If VH not equal 0
IOP3	= 0 NO polarization plot = 1 Call PLOT
IOP4	Dummy variable used in GD plot routines
IREC	Starting record; must be 1, 2, 5, 10 or greater
NR	Number of files to be processed
L	Number of aspect angles to be processed
INC	Theta increment x 10
DRHO	Delta rho: polarization increment
LP	Print out increment for library data
LIM1	Lower limit for end around test for phase
LIM2	Upper limit for end around test for phase

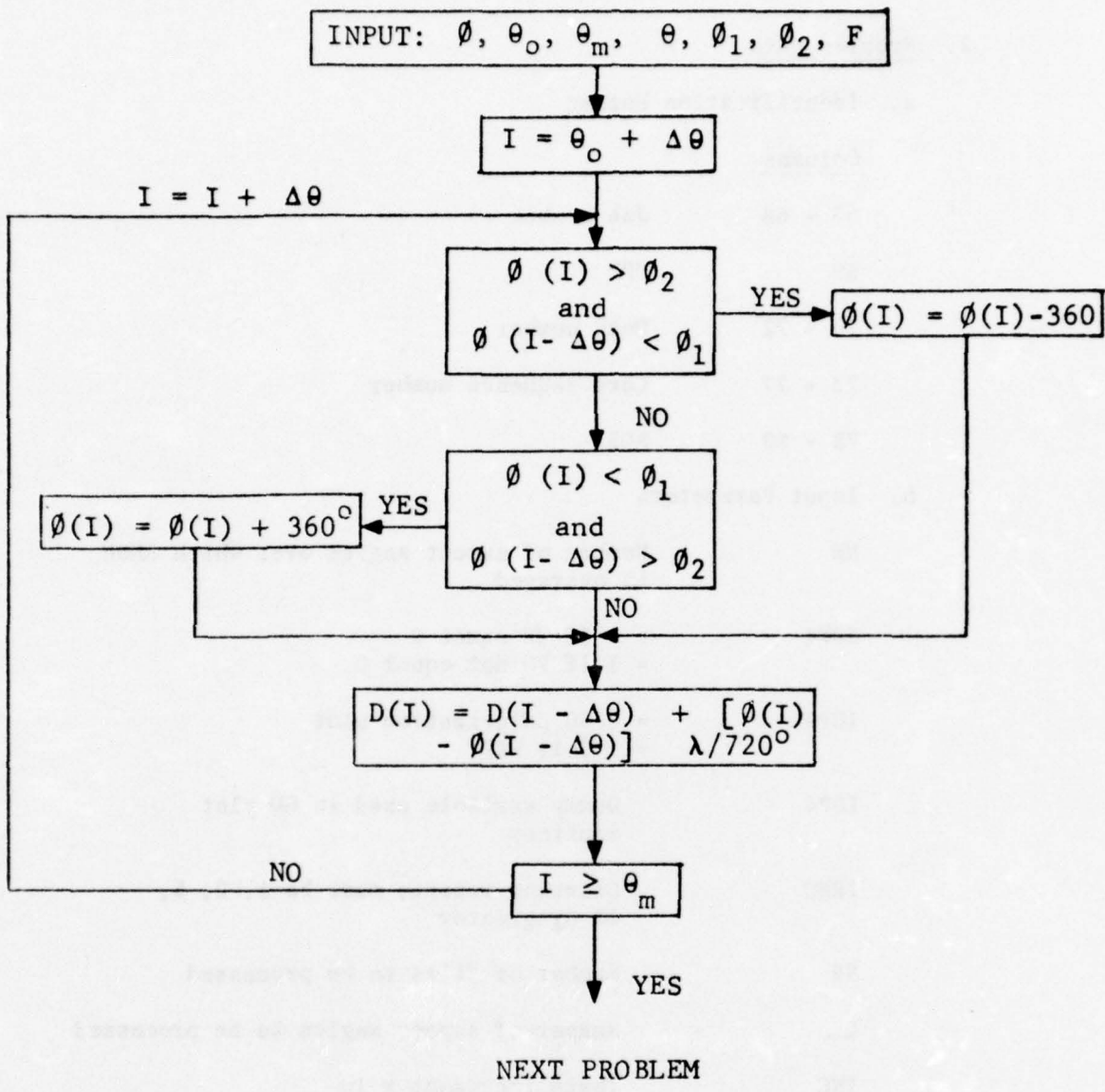

Figure 2 PHASE SUBROUTINE FLOW DIAGRAM

F	Frequency in gigahertz (= 0. for no phase)
TLOW	Threshold level for polarization comparison
LPRO	Print out increment for polarization ratio
LPTH	Print out increment for theta
NFILE	Number of files on tape
IFN(I)	File number for problem number I
HDG	28 column alphanumeric heading data

c. Cord Formats

(i) First cord of each problem deck

Cord						
Cols.	1-10	11-20	21-30	31-40	41-50	51-60
Data	IOP1	IOP2	IREC	NR	L	INC

(ii) Second cord of each problem deck

Cord						
Cols.	1-10	11-20	21-30	31-40	41-50	51-60
Data	DRHO	LP	LIM1	LIM2	F	NFILE

(iii) Third cord of each problem deck

Cord								
Cols.	1-10	11-20	21-30	31-40	41-50	51-60	61	62
Data	NN	TLOW	LPRO	LPTH	IRMI	IRMA	IOP3	IOP4

(iv) Fourth cord of each problem deck

Cord			
Cols.	1-2	3-10	11-28
Data	IFN(I)	BLANK	HDG(II), II = 1, 7

All input items except those beginning with the letters with the letters I, J, K, L, M or N must contain a decimal point and may contain an exponent (power of ten by which the number is multiplied) in the right most columns of its field. The exponent may be omitted if the last column of the field is blank. When input the

exponent is preceded by its sign or the character E and contains no decimal point. Items beginning with the letters I, J, K, L, M or N must be right adjusted in their respective fields.

5.2 Output Data. The output of this procedure consists of:

1. RHOL1, RHOL2      Polarization signature ratios.  
These are listed in the output.
2. RHOH1, RHOH2      Averaged values of RHOL1 and RHOL2  
over a set of NN aspect angles.  
These values are plotted vs aspect  
angle on the EAI plotter.
3. A plot of the absolute phase of the target in radians  
vs aspect angle

5.3 Time Estimate. Approximately eight minutes are required to run one problem using AG3.

```

C      POLARIZATION SIGNATURE TECHNIQUE PROGRAM
C
COMMON/BLOK/NEOR,NSKIP,RHOH1(4000),RHOL1(4000),RHOHZ1(4000),RHOL2
1(4000),IOP1,IOP2,IREC,NR,L,INC,DRHO,LP,LIM1,LIM2,F,NFILE,K,XR,SHH,
1 LL,RPD,KOP1,MIN,MAX,J,SVV,XI,VVR,TJVV,TJHH,COSVV,VVI,SINVV,COSHH,
2 SINHH,HHR,HHI,SIGR,SIGI,PERR,PERI,SUM,DENOM1,DENOM2,TJVH,SVH,
3 COSVH,SINVH,VHR,VHI,XLAMDA,IFN(20),HDG(7),IX(2),IY(2),
4 IVV(4000),JVV(4000),IVH(4000),JVH(4000),IHH(4000),JHH(4000),
5 SINSQ(3600),COSSQ(3600),SICOS(3600),RATIO(3600),IRMI,IRMA
6,RATION(4000),LPTH,IH1(2),IL1(2),IH2(2),IL2(2),IYH(2),NEOF
C **      A81 LIBRARY TAPE MOUNTED ON UNIT 8
C      NN = NUMBER OF ASPECT ANGLES OVER WHICH RHOH IS AVERAGED
C      IOP1 = 0 IF VH.EQ.0 ** = 1 IF VH.NE.0
C      IOP3 = 0 NO POLARIZATION PLOT ** = 1 CALL PLTOP
C      IREC = STARTING RECORD * MUST BE 1,2,5,10, OR GREATER
C      NR = NUMBER OF FILES TO BE PROCESSED
C      L = NUMBER OF ASPECT ANGLES TO BE PROCESSED
C      INC = THETA INCREMENT X10
C      DRHO = DELTA RHO ** POLARIZATION INCREMENT
C      LP = PRINT OUT INCREMENT FOR LIBRARY DATA
C      LIM1 = LOWER LIMIT FOR END AROUND TEST FOR PHASE
C      LIM2 = UPPER LIMIT FOR END AROUND TEST FOR PHASE
C      F = FREQUENCY IN GIGIHERTZ (= 0. FOR NO PHASE)
C      TLOW = THRESHOLD LEVEL FOR POLARIZATION COMPARISON
C      LPRO = PRINT OUT INCREMENT FOR POLARIZATION **RATIO**
C      LPTH = PRINT OUT INCREMENT FOR THETA
C      NFILE = NUMBER OF FILES ON TAPE
C      IFN(I) = FILE NUMBER FOR PROBLEM NUMBER *I*
C      HDG = 28 COLUMN APLANUMERIC HEADING DATA
10 REWIND 8
   NEOF=
   READ (5,11) IOP1,IOP2,IREC,NR,L,INC
11 FORMAT (6I10)
   READ (5,12) DRHO,LP,LIM1,LIM2,F,NFILE
12 FORMAT (F10.0,3I10,F10.3,I10)
   READ (5,13) NN,TLOW,LPRO,LPTH,IRMI,IRMA,IOP3,IOP4
13 FORMAT (I10,F10.3,4I10,2I1)
   I=0
14 I = I+1
   READ (5,24) IFN(I),(HDG(II),(II=1,7)),DPHIH,DPHIV
24 FORMAT (I2,8X,7A4,2I10)
   WRITE (6,26)
26 FORMAT (19H1 INPUT DATA VALUES)
   WRITE(6,9998)( HDG(IIII),IIII =1,7)
9998 FORMAT (1H ,7A4 )
   WRITE (6,11) IOP1,IOP2,IREC,NR,L,INC
   WRITE (6,12) DRHO,LP,LIM1,LIM2,F,NFILE
   WRITE (6,13) NN,TLOW,LPRO,LPTH,IRMI,IRMA,IOP3,IOP4
   NN = (NN/2)*2+1
   WRITE(6,5050) NN
5 50 FORMAT(1H0,14HCOMPUTED NN = ,I4)
2226 IF (IREC.GE.10) GO TO 4000

```

```

GO TO (4000,4000,3900,3900,4000,3900,3900,3900,3900),IREC
3900 WRITE (6,3901) IREC
3901 FORMAT(1H0,18H THE VALUE OF IREC, .I2,1X,25H, IS NOT ACCEPTABLE TO AC
A3)
GO TO 10
4 00 DO 4 K=1,L
RHOH1(K) = -10.0
RHOL1(K) = -10.0
RHOH2(K) = -10.0
400 RHOL2(K) = -10.0
NEOF = 0
NEOR = 0
NCNO = 0
IF (I.GT.1) GO TO 29
DO 27 IS=1,7
NS=IS
27 READ (8,28) SYMBOL
28 FORMAT (77X,A3)
DATA RH4/4HRH4 /
IF (NS.EQ.7) BACKSPACE 8
IF (SYMBOL.EQ.RH4) GO TO 29
WRITE (6,20) SYMBOL
20 FORMAT (30H INCORRECT SYMBOL IN COL.78-80,3X,A3)
29 IF (I.EQ.1) GO TO 40
IF (IFN(I).EQ.IFN(I-1)) CALL ERROR(1 )
IF (IFN(I).LT.IFN(I-1)) GO TO 30
NSKIP = IFN(I) - IFN(I-1) - 1
GO TO 50
30 REWIND 8
40 NSKIP = IFN(I) - 1
50 CALL SKIPF(NEOF,NEOR,NSKIP)
IRSK = IREC-1
CALL SKIPR(IRSK)
READ (8,60) (IHH(K),JHH(K),IVV(K),JVV(K),IVH(K),JVH(K),K=1,L)
60 FORMAT ( 3X,6X,2I4,6X,2I4,6X,2I4)
WRITE (6,60) (IHH(K),JHH(K),IVV(K),JVV(K),IVH(K),JVH(K),K=1,L,LP)
IF(DRHO .LE. 0.) GO TO 370
C
RPD = 3.14159/180.0
LL= 90.0 / DRHO +1.
DRHO=DRHO*RPD
DO 7 J = 1,LL
ZA5 = J-1
SINSQ(J) = (SIN((ZA5)*DRHO))**2
COSSQ(J) = (COS((ZA5)*DRHO))**2
SICOS(J) = SIN((ZA5)*DRHO)*COS((ZA5)*DRHO)
70 CONTINUE
M = 1
K=1
GO TO 72
71 K = K + INC
72 NF =

```

```

NL = 1
ZA8 = JVV(K)
TJVV = ( ZA8 + DPHIV ) * RPD
ZA9 = JHH(K)
TJHH = ( ZA9 + DPHIH ) * RPD
COSVV = COS(TJVV)
SINVV = SIN(TJVV)
COSHH = COS(TJHH)
SINHH = SIN(TJHH)
ZA10 = IVV(K)
SVV = 10.0** ( ZA10/200.0 )
ZA11 = IHH(K)
SHH = 10.0** ( ZA11/200.0 )
VVR = SVV * COSVV
VVI = SVV * SINVV
HHR = SHH * COSHH
HHI = SHH * SINHH
IF ( IOP1 ) 110, 80, 110
80 J = 1
81 SIGR = VVR * SINSQ(J) + HHR * COSSQ(J)
SIGI = VVI * SINSQ(J) + HHI * COSSQ(J)
PERR = VVR * COSSQ(J) + HHR * SINSQ(J)
PERI = VVI * COSSQ(J) + HHI * SINSQ(J)
XR = SIGR - PERR
XI = SIGI - PERI
SUM = SQRT( XR ** 2 + XI ** 2 )
DENOM1 = SQRT( SIGR ** 2 + SIGI ** 2 )
DENOM2 = SQRT( PERR ** 2 + PERI ** 2 )
RATIO(J) = SUM / ( DENOM1 + DENOM2 )
IF ( RATIO(J) - 10.0** (-8) ) 85, 85, 90
85 RATIO(J) = -160.0
GO TO 100
90 RATIO(J) = 10.0 * ALOG10( RATIO(J) )
100 CONTINUE
GO TO 200
110 J = 1
ZA12 = JVH(K)
111 TJVH = ZA12 * RPD
JL1 = 0
JL2 = 0
JH1 = 0
JH2 = 0
COSVH = COS(TJVH)
SINVH = SIN(TJVH)
ZA13 = IVH(K)
SVH = 10.0** ( ZA13/200.0 )
VHR = SVH * COSVH
VHI = SVH * SINVH
SIGR = VVR * SINSQ(J) + ( 2.0 * VHR ) * SICOS(J) + HHR * COSSQ(J)
SIGI = VVI * SINSQ(J) + ( 2.0 * VHI ) * SICOS(J) + HHI * COSSQ(J)
PERR = VVR * COSSQ(J) - ( 2.0 * VHR ) * SICOS(J) + HHR * SINSQ(J)
PERI = VVI * COSSQ(J) - ( 2.0 * VHI ) * SICOS(J) + HHI * SINSQ(J)

```

```

XR = SIGR - IERR
XI = SIGI - PERI
SUM = SQRT( XR ** 2 + XI ** 2)
DENOM1 = SQRT( SIGR ** 2 + SIGI ** 2)
DENOM2 = SQRT( PERR ** 2 + PERI ** 2)
RATIO(J) = SUM / (DENOM1 + DENOM2)
IF (RATIO(J)-10.0**(-8)) 115,115,117
115 RATIO(J) = -160.0
GO TO 200
117 RATIO(J) = 20.0 * ALOG10(RATIO(J))
200 CONTINUE
201 IF (NL.NE.1) GO TO 202
IF (RATIO(J).GT.TLOW) GO TO 202
NL = NL+1
ZA14 = J-1
RHOL1(K) = ((ZA14)*DRHO)/RPD
JL1 = J-1
202 IF (RATIO(J).GT.TLOW) GO TO 204
ZA15 = J-1
RHOL2(K) = ((ZA15)*DRHO)/RPD
JL2 = J-1
204 IF (J.GE.LL) GO TO 206
IF (IOP1.NE.0) GO TO 205
J = J+1
GO TO 81
205 J = J+1
GO TO 111
206 IF ((M-K).NE.C) GO TO 208
M = M+LPTH*INC
WRITE (6,207) K,(RATIO(J),J=1,LL,LPRO)
207 FORMAT (23H ASPECT ANGLE NUMBER = ,I5,/(3F20.4))
WRITE (6,209) JL1,RHOL1(K),JL2,RHOL2(K)
D)
209 FORMAT (
D,7H RHOL1(,I5,3H)= ,E20.7,10X,7H RHOL2(,I5,3H)= ,E20.7)
208 IF (K.LT. L) GO TO 71
DO 2090 K=1,L
2 90 WRITE (6,2091) K,RHOL1(K),K,RHOL2(K)
2 91 FORMAT (1H0,6HRHOL1(,I4,2H)=,E20.7,5X, 6HRHOL2(,I4,2H)=,E20.7)
N2N = NN-1
N2N = NN/2
N2N1 = N2N + 1
K11 = 1 + INC
K12 = 1 + N2N*INC
K13 = L -(N2N-1)*INC
K = 1
RHOH2(1) = RHOL1(1)
DO 51 KIK = 1,N2N
JKJ16 = 1+KIK*INC
510 RHOH2(1) = RHOH2(1) + RHOL1(JKJ16)
ZA17 = N2N1
RHOH1(1) = RHOH2(1) / ZA17

```

```

      JJJ = 0
      DO 52 K = KL1, KL2, INC
      JJJ = JJJ + 1
      JKJ18 = K - INC
      RHOH2(K) = RHOH2(JKJ18)
      JKJ19 = K + N2N * INC
      RHOH2(K) = RHOH2(K) + RHOL1(JKJ19)
      ZA20 = N2N1 + JJJ
520  RHOH1(K) = RHOH2(K) / (ZA20)
      WRITE(6, 5000) KL2, RHOH1(KL2)
      K = KL2
598  K = K + INC
      JKJ21 = K - ((N1N)/2) * INC
      RHOH2(K) = RHOL1(JKJ21)
600  DO 70 KK = 1, N1N
      JKJ22 = K - ((N1N)/2 - KK) * INC
700  RHOH2(K) = RHOH2(K) + RHOL1(JKJ22)
      ZA23 = NN
      RHOH1(K) = RHOH2(K) / ZA23
      IF (K.LT.L - N2N * INC) GO TO 598
      WRITE(6, 5000) K, RHOH1(K)
      JJJ = 0
      DO 63 K = KL3, L, INC
      JJJ = JJJ + 1
      JKJ24 = K - INC
      JKJ24A = K - N2N * INC
      RHOH2(K) = RHOH2(JKJ24) - RHOL1(JKJ24A)
      ZA25 = NN - JJJ
630  RHOH1(K) = RHOH2(K) / ZA25
      WRITE(6, 5000) L, RHOH1(L)
5 00  FORMAT (1H0, 6HRHOH1(, I4, 2H) =, E20.7)
      K = 1
      RHOL1(1) = RHOL2(1)
      DO 810 KIK = 1, N2N
      JKJ26 = 1 + KIK * INC
810  RHOL1(1) = RHOL1(1) + RHOL2(JKJ26)
      ZA27 = N2N1
      RHOH2(1) = RHOL1(1) / ZA27
      JJJ = 0
      DO 82 K = KL1, KL2, INC
      JJJ = JJJ + 1
      JKJ28 = K - INC
      RHOL1(K) = RHOL1(JKJ28)
      JKJ29 = K + N2N * INC
      RHOL1(K) = RHOL1(K) + RHOL2(JKJ29)
      ZA30 = N2N1 + JJJ
820  RHOH2(K) = RHOL1(K) / ZA30
      WRITE(6, 8000) KL2, RHOH2(KL2)
      K = KL2
898  K = K + INC
      JKJ31 = K - ((N1N)/2) * INC
      RHOL1(K) = RHOL2(JKJ31)

```

```

900 DO 100 KK = 1, N1N
    JKJ32 = K - ((N1N)/2 - KK) * INC
1 00 RHOL1(K) = RHOL1(K) + RHOL2(JKJ32)
    ZA33 = NN
    RHOH2(K) = RHOL1(K) / ZA33
    IF (K.LT.L - N2N * INC) GO TO 898
    WRITE(6,8000) K , RHOH2(K)
    JJJ = 0
    DO 93 K = KL3, L, INC
    JJJ = JJJ + 1
    JKJ34 = K - INC
    JKJ34A = K - N2N1 * INC
    RHOL1(K) = RHOL1(JKJ34) - RHOL2(JKJ34A)
    ZA35 = NN - JJJ
930 RHOH2(K) = RHOL1(K) / ZA35
    WRITE(6,8000) L , RHOH2(L )
9 01 FORMAT(1H0,I4,E20.7,E20.7)
8 00 FORMAT(1H0,6H RHOH2(,I4,2H)=,E20.7)
    IF (IOP3.NE.1) GO TO 370
C ** RHOH1 IS LOWER LIMIT OF POLARIZATION ENVELOPE
C ** RHOH2 IS UPPER LIMIT OF POLARIZATION ENVELOPE
217 CALL PLTPOL(RHOH1,RHOH2 , INC , L )
370 IF (F.EQ.0.) GO TO 380
C ** RATIO IS CUMULATIVE PHASE FOR VERTICAL POLARIZATION
C ** RATIOH IS CUMULATIVE PHASE FOR HORIZONTAL POLARIZATION
375 CALL PHASE
380 CONTINUE
    IF (I.LT.NR) GO TO 14
421 WRITE (6,422)
422 FORMAT (1H , 2H THIS JOB IS COMPLETE.)
    STOP
    END

```

```

1          SUBROUTINE PLTPOL ( RHOH1 , RHOH2 , INC , L )
2  C SUBROUTINE PLTPOL *** PLOTS RHOH1 AND RHOH2 VERSUS ASPECT
3  DIMENSION XPAR(8) , YPAR(8) , XAR(360) , YAR(360) , ZAR(360)
4  DATA XPAR / 0.0, 29.0, 2.0, 200., 17.0, 0., 1.8, 0.1 /
5  DATA YPAR / 0.0, 29.0, 5.0, 10., 12.0, 0., 3.5, 0.0 /
6  IF (INC.GE.10) GO TO 215
7  INCP = 10
8  GO TO 217
9  215 INCP = INC
10 217 CONTINUE
11  C ***
12  1 CALL NUMBER(-180., 1, XPAR , YPAR )
13  XPAR(7) = 6.3
14  CALL NUMBER( -90., 1, XPAR , YPAR )
15  XPAR(7) = 10.8
16  CALL NUMBER( 0., 1, XPAR , YPAR )
17  XPAR(7) = 15.3
18  CALL NUMBER( 90., 1, XPAR , YPAR )
19  XPAR(7) = 19.8
20  CALL NUMBER( 180., 1, XPAR , YPAR )
21  XPAR(7) = 1.0
22  YPAR(7) = 4.0
23  CALL NUMBER( -10., 1, XPAR , YPAR )
24  YPAR(7) = 5.
25  CALL NUMBER( 0., 1, XPAR , YPAR )
26  YPAR(7) = 9.5
27  CALL NUMBER( 45., 1, XPAR , YPAR )
28  YPAR(7) = 14.
29  CALL NUMBER( 90., 1, XPAR , YPAR )
30  IBM = L - INCP
31  J = 0
32  DO 20 K = 1, IBM, INCP
33  J = J + 1
34  XAR(J) = K
35  YAR(J) = RHOH1(K)
36  ZAR(J) = RHOH2(K)
37  DO LOOP INDEX K MAY NOT BE REDEFINED IN CALL OR ABNORMAL FUNCTION
38  DO LOOP INDEX K MAY NOT BE REDEFINED IN CALL OR ABNORMAL FUNCTION
39  II = J
40  20 CONTINUE
41  C ***
42  CALL LINE ( XAR , YAR , II , XPAR, YPAR )
43  CALL LINE ( XAR , ZAR , II , XPAR, YPAR )
44  CALL STDBY
45  RETURN
46  END

```

```

1      SUBROUTINE PLTPHA (RATIO ,RATIOH, INC, L      )
2      DIMENSION XPAR(8) , YPAR(8) , XAR(360) , YAR(360) , ZAR(360)
3      DATA XPAR / 0.0, 29.0, 2.0, 20.0, 17.0, 0. , 1.8, 0.1 /
4      DATA YPAR / 0.0 , 29.0 , 15.0 , 10.0 , 12.0 , 0.0 , 15.0, 0.0/
5      IF (INC.GE.10) GO TO 85
6      INCP = 10
7      GO TO 90
8      85 INCP = INC
9      90 CONTINUE
1     C ***
11     1 CALL NUMBER(-180. , 1, XPAR , YPAR )
12     XPAR(7) = 6.3
13     CALL NUMBER(-90. , 1, XPAR , YPAR )
14     XPAR(7) = 10.8
15     CALL NUMBER( 0. , 1, XPAR , YPAR )
16     XPAR(7) = 15.3
17     CALL NUMBER( 90. , 1, XPAR , YPAR )
18     XPAR(7) = 19.8
19     CALL NUMBER( 180. , 1, XPAR , YPAR )
20     XPAR(7) = 1.0
21     CALL NUMBER ( 0.0 , 1 , XPAR, YPAR )
22     YPAR(7) = 20.0
23     CALL NUMBER ( 10.0 , 1 , XPAR, YPAR )
24     YPAR(7) = 25.0
25     CALL NUMBER ( 20.0 , 1 , XPAR, YPAR )
26     YPAR(7) = 28.0
27     CALL NUMBER ( 26.0 , 1 , XPAR, YPAR )
28     IBM = L - INCP
29     J = 0
30     DO 20 K = 1, IBM, INCP
31     J = J + 1
32     XAR(J) = K
33     YAR(J) = RATIO(K)
DO LOOP INDEX K MAY NOT BE REDEFINED IN CALL OR ABNORMAL FUNCTION
34     ZAR(J) = RATIOH(K)
DO LOOP INDEX K MAY NOT BE REDEFINED IN CALL OR ABNORMAL FUNCTION
35     II = J
36     20 CONTINUE
37     C ***
38     CALL LINE ( XAR , YAR , II , XPAR, YPAR )
39     CALL LINE ( XAR , ZAR , II , XPAR, YPAR )
40     CALL STDBY
41     CALL STDBY
42     RETURN
43     END

```

```

SUBROUTINE SKIPF(NEOF,NEOR,NSKIP)
1 IF (NSKIP,EQ.0) GO TO 110
  NCNO = 0
  NFS = 0
  NCNO1 = NCNO
  CALL FLGEOF(8,IEOF)
10 READ (8,15) NCNO
  IF(IEOF,EQ.1) GO TO 40
15 FORMAT (72X,15,3X)
  IF (NCNO.GE.NCNO1) GO TO 20
  NEOF = NEOF+1
  NFS = NFS + 1
20 IF (NCNO.NE.1) GO TO 10
  IF (NFS.LT.NSKIP) GO TO 10
  BACKSPACE 8
30 RETURN
40 CALL ERROR(2 )
  GO TO 30
  ENTRY SKIPR(IRSK)
  NRS = 0
  IF (IRSK.EQ.0) GO TO 110
  CALL FLGEOF(8,IEOF)
  IF(IEOF,EQ.1) GO TO 100
80 READ (8,90) DUMMY
90 FORMAT (1X)
  NEOR = NEOR + 1
  NRS = NRS + 1
  IF (NRS.LT.IRSK ) GO TO 80
  GO TO 110
100 CALL ERROR( 3)
110 RETURN
  END

```

```
      SUBROUTINE ERROR(KERROR)
      GO TO (10 , 20 , 30      ),KERROR
10  WRITE(6 , 100)
100 FORMAT(39H  WRONG TAPE FILE CALLED * KERROR = 1  )
      GO TO 110
20  WRITE(6 , 200)
200 FORMAT(39H  UNEXPECTED END OF FILE * KERROR = 2  )
      GO TO 110
30  WRITE(6 , 300)
300 FORMAT(39H  UNEXPECTED END OF FILE * KERROR = 3  )
110 STOP
      END
```

C  
C  
C

SUBROUTINE PHASE PHASE CENTER ANALYSIS

```

COMMON/BLOK/NEOR,NSKIP,RHOH1(4000),RHOL1(4000),RHOH2(4000),RHOL2
1(4000),IOP1,IOP2,IREC,NR,L,INC,DRHO,LP,LIM1,LIM2,F,NFILE,K,XR,SHH,
1 LL,RPD,KOP1,MIN,MAX,J,SVV,XI,VVR,TJVV,TJHH,COSVV,VVI,SINVV,COSHH,
2 SINHH,HHR,HHI,SIGR,SIGI,PERR,PERI,SUM,DENOM1,DENOM2,TJVH,SVH,
3 COSVH,SINVH,VHR,VHI,XLAMDA,IFN(20),HDG(7),IX(2),IY(2),
4 IVV(4000),JVV(4000),IVH(4000),JVH(4000),IHH(4000),JHH(4000),
5 SINSQ(3600),COSSQ(3600),SICOS(3600),RATIO(3600),IRMI,IRMA
6,RATIOH(4000),LPTH,IH1(2),IL1(2),IH2(2),IL2(2),IYH(2),NEOF
XLAMDA = 3.0/(10.0*F*0.0254)/720.0
ZAH1 = JVV(1)
RATIO(1) = ZAH1*XLAMDA
MM=1+INC
DO 3 I=MM,L,INC
MPHI = 0
JKJH2 = I-INC
IF (JVV(I).LT.LIM2, OR,JVV(JKJH2).GT.LIM1) GO TO 25
9 01 MPHI = -360
GO TO 30
25 JKJH4 = I-INC
IF (JVV(I).GT.LIM1, OR,JVV(JKJH4).LT.LIM2) GO TO 30
9 00 MPHI = 360
JKJH6 = I-INC
ZAH6 = (JVV(I)-JVV(JKJH6))+MPHI
30 RATIO(I) = RATIO(JKJH6) + ZAH6*XLAMDA
WRITE (6,41)
41 FORMAT (1H0,39HOUTPUT DATA,PHASE CENTER IN INCHES (VV))
WRITE (6,40) (RATIO(I), I = 1,L,LPTH)
40 FORMAT (5F8.3)
ZAH7 = JHH(1)
RATIOH(1) = ZAH7*XLAMDA
DO 70 I=MM,L,INC
MPHI = 0
JKJH8 = I-INC
IF (JHH(I).LT.LIM2, OR,JHH(JKJH8).GT.LIM1) GO TO 60
9 02 MPHI = -360
GO TO 70
60 JKH10 = I-INC
IF (JHH(I).GT.LIM1, OR,JHH(JKH10).LT.LIM2) GO TO 70
9 03 MPHI = 360
JKJH12 = I-INC
ZAH12 = JHH(I)-JHH(JKJH12)+MPHI
70 RATIOH(I) = RATIOH(JKJH12) + ZAH12*XLAMDA
WRITE (6,79)
79 FORMAT (1H0,39HOUTPUT DATA,PHASE CENTER IN INCHES (HH))
WRITE (6,80) (RATIOH(I), I=1,L,LPTH)
80 FORMAT (5F8.3)
CALL PLTPHA(RATIO,RATIOH,INC,L)
RETURN

```

END

(the reverse of this page is blank)

## 8. SAMPLE PROBLEM

8.1. Description. A sample problem is included for checking out program AG3.

8.2. Input Data. The input data used for the sample problem is shown on the following page. The input data is explained in Section 5.1.

8.3 Output Data. A portion of the output from Procedure AG3 for the sample problem is given on the following pages.

0	0	1	1	3600	1
2.0	50	90	270	0.0	3
7	-15.0	2	.100	-5	301

1

AI

TLOW=-15 C02666 NN=7

TL0W = -15 C02666 VNN = 7

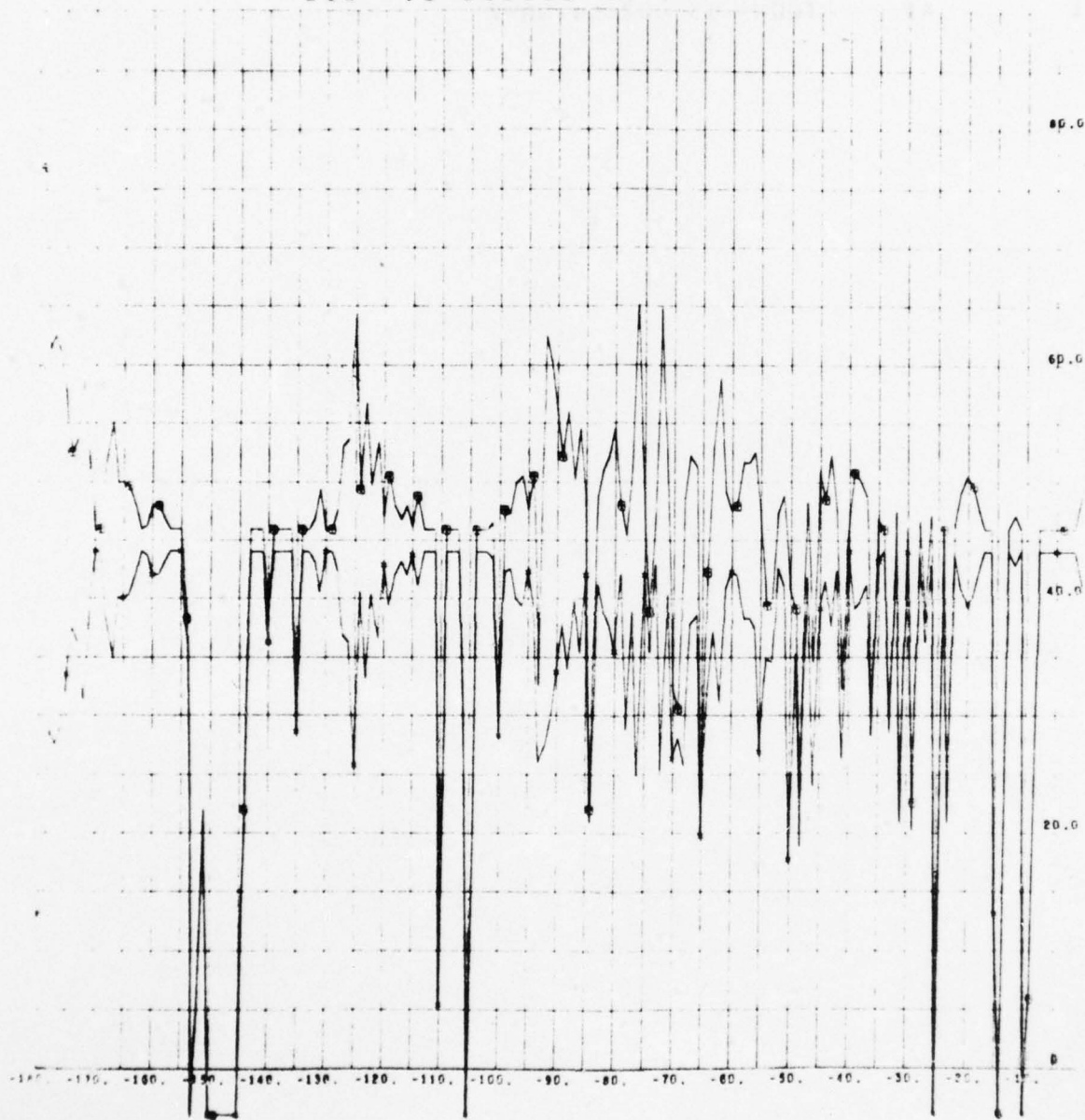

POLARIZATION SYMMETRY ENVELOPE

TL0W=-15 C02666RNN=7

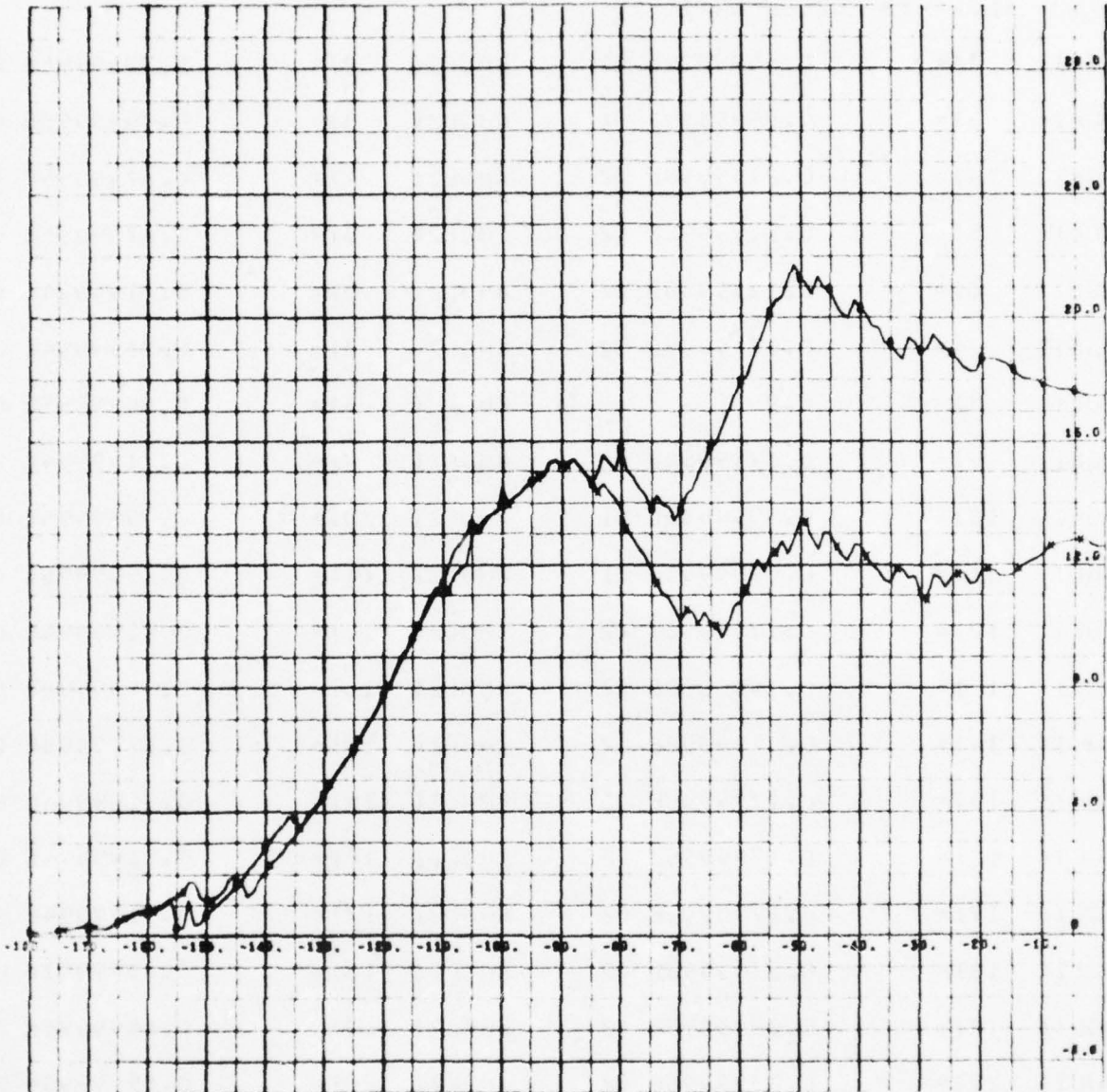

ABSOLUTE PHASE SIGNATURES

A1 TL0n=-15 C02000 NN=7

RHOL1( 2)=	0.9999999E 01	RHOL2( 2)=	0.7999995E 02
RHOL1( 3)=	0.9999999E 01	RHOL2( 3)=	0.7999995E 02
RHOL1( 4)=	0.2199998E 02	RHOL2( 4)=	0.6799995E 02
RHOL1( 5)=	0.2199998E 02	RHOL2( 5)=	0.6799995E 02
RHOL1( 6)=	0.1799998E 02	RHOL2( 6)=	0.7199994E 02
RHOL1( 7)=	0.1799998E 02	RHOL2( 7)=	0.7199994E 02
RHOL1( 8)=	0.0	RHOL2( 8)=	0.8999997E 02
RHOL1( 9)=	0.1799998E 02	RHOL2( 9)=	0.7199994E 02
RHOL1( 10)=	0.9999999E 01	RHOL2( 10)=	0.7999995E 02
RHOL1( 11)=	0.9999999E 01	RHOL2( 11)=	0.7999995E 02
RHOL1( 12)=	0.1799998E 02	RHOL2( 12)=	0.7199994E 02
RHOL1( 13)=	0.1400000E 02	RHOL2( 13)=	0.7599998E 02
RHOL1( 14)=	0.2199998E 02	RHOL2( 14)=	0.6799995E 02
RHOL1( 15)=	0.1799998E 02	RHOL2( 15)=	0.7199994E 02
RHOL1( 16)=	0.1799998E 02	RHOL2( 16)=	0.7199994E 02
RHOL1( 17)=	0.1799998E 02	RHOL2( 17)=	0.7199994E 02
RHOL1( 18)=	0.2399998E 02	RHOL2( 18)=	0.6599997E 02
RHOL1( 19)=	0.2399998E 02	RHOL2( 19)=	0.6599997E 02
RHOL1( 20)=	0.3399998E 02	RHOL2( 20)=	0.5599998E 02
RHOL1( 21)=	0.3399998E 02	RHOL2( 21)=	0.5599998E 02
RHOL1( 22)=	0.2999998E 02	RHOL2( 22)=	0.5999994E 02
RHOL1( 23)=	0.2399998E 02	RHOL2( 23)=	0.6599997E 02
RHOL1( 24)=	0.2999998E 02	RHOL2( 24)=	0.5999994E 02
RHOL1( 25)=	0.2799998E 02	RHOL2( 25)=	0.6199993E 02
RHOL1( 26)=	0.2599998E 02	RHOL2( 26)=	0.6399998E 02
RHOL1( 27)=	0.2599998E 02	RHOL2( 27)=	0.6399998E 02

A1 TLOW=-15 CC2666 NN=7

RHOL1( 28)=	0.2199998E 02	RHOL2( 28)=	0.6799995E 02
RHOL1( 29)=	0.2599998E 02	RHOL2( 29)=	0.6399998E 02
RHOL1( 30)=	0.3399998E 02	RHOL2( 30)=	0.5599998E 02
RHOL1( 31)=	0.2399998E 02	RHOL2( 31)=	0.5599998E 02
RHOL1( 32)=	0.2199998E 02	RHOL2( 32)=	0.6799995E 02
RHOL1( 33)=	0.2599998E 02	RHOL2( 33)=	0.6399998E 02
RHOL1( 34)=	0.2799998E 02	RHOL2( 34)=	0.6199998E 02
RHOL1( 35)=	0.2999998E 02	RHOL2( 35)=	0.5999994E 02
RHOL1( 36)=	0.2599998E 02	RHOL2( 36)=	0.6399998E 02
RHOL1( 37)=	0.2599998E 02	RHOL2( 37)=	0.6599997E 02
RHOL1( 38)=	0.2799998E 02	RHOL2( 38)=	0.6199998E 02
RHOL1( 39)=	0.2799998E 02	RHOL2( 39)=	0.6199998E 02
RHOL1( 40)=	0.2799998E 02	RHOL2( 40)=	0.6199998E 02
RHOL1( 41)=	0.2999998E 02	RHOL2( 41)=	0.5999994E 02
RHOL1( 42)=	0.2999998E 02	RHOL2( 42)=	0.5999994E 02
RHOL1( 43)=	0.2999998E 02	RHOL2( 43)=	0.5999994E 02
RHOL1( 44)=	0.2799998E 02	RHOL2( 44)=	0.6199998E 02
RHOL1( 45)=	0.2999998E 02	RHOL2( 45)=	0.5999994E 02
RHOL1( 46)=	0.3200000E 02	RHOL2( 46)=	0.5799995E 02
RHOL1( 47)=	0.2999998E 02	RHOL2( 47)=	0.5999994E 02
RHOL1( 48)=	0.2999998E 02	RHOL2( 48)=	0.5999994E 02
RHOL1( 49)=	0.2999998E 02	RHOL2( 49)=	0.5999994E 02
RHOL1( 50)=	0.3399998E 02	RHOL2( 50)=	0.5599998E 02
RHOL1( 51)=	0.3599998E 02	RHOL2( 51)=	0.5399998E 02
RHOL1( 52)=	0.3399996E 02	RHOL2( 52)=	0.5599998E 02
RHOL1( 53)=	0.3399998E 02	RHOL2( 53)=	0.5599998E 02

SECTION VII

SIGNATURE TYPE AMBIGUITY STUDY  
COMPUTER PROGRAM DOCUMENTATION



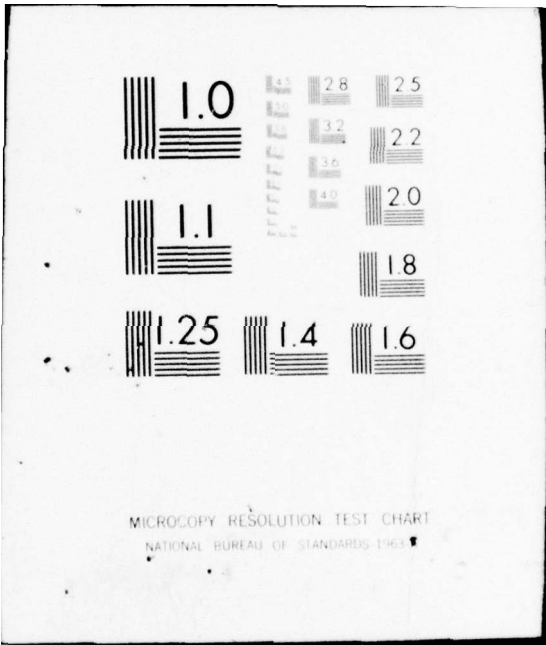

MICROCOPY RESOLUTION TEST CHART  
NATIONAL BUREAU OF STANDARDS-1963-A

Enclosure (B)

H65 - FORTRAN IV SOURCE DECK LISTING

C  
C  
C

SIGNATURE TYPE AMBIGUITY STUDY

COMMON

✓ 1/AA1/SMAT(37CC,6) M1(6), ACUT1, ACUT2,

2 ACUT3, ACUT4

DIMENSION AP(37CC), E(37CC), FF1(6), EE2(6), E1(6)

✓ NTA = NTA

REWIND NTA

NO11=-1

ACUT1=18C.

ACUT2=0.

ACUT3=360.

ACUT4=181.

20 READ(5,1005) NNN, TN, MN, SN, SAN, NS, AVGMA

21 READ(5,1000) K, A1, A2, A3, A4, A5, J

GL TO (30,40,50,60,70,80,90,100) ,K

30 NC=J

GO TO 21

40 ISAN=J

AVGN=A2

NSS=J

GO TO 21

50 M1(2)=A1+.1

M1(3)=A2+.1

M1(4)=A3+.1

M1(5)=A4+.1

M1(6)=A5+.1

GO TO 21

60 E1(2)=A1

E1(3)=A2

E1(4)=A3

E1(5)=A4

E1(6)=A5

GO TO 21

70 ACUT1=A1

ACUT2=A2

ACUT3=A3

ACUT4=A4

ISMVAR=A5+.1

GO TO 21

80 IOPT=A1+.1

GO TO 21

90 DNGRMA =A1

GO TO 21

100 WRITE (6,1006) NNN, TN, MN, SN, SAN, AVGMA, NS,

1 E1(2), E1(3), E1(4), E1(5), E1(6) ,  
2 ACUT1, ACUT2, ACUT3, ACUT4, ISMVAR

C  
C  
C

FIND CORRECT SCATTERING MATRIX DATA ON TAPE

CALL FLGECF(NTA, IEDF)

IF (NC .NE. NO11) GO TO 101

DO 105 I=1, NUM

105 SMAT(I,1)=APS(SMAT(I,1))

```

      GO TO 18C
101 IF (NO11 .EQ. -1 ) GO TO 103

102 READ (NTA)
    IF (IEOF) 102,102,103

103 IEOF = C
    READ (NTA)
    LOC=103
    IF (IEOF) 104,104,550
104 READ (NTA) NO1
    LOC=104
    IF (IECF) 106,106,550
106 IF (NO .EQ. NO1) GO TO 140
110 READ (NTA)
    IF (IEOF) 110,110,103
C   READ IN SCATTERING MATRIX
140 I=1
    NUM=0
141 READ (NTA) (SMAT(I,J),J=1,6)
    LOC=141
    IF (IECF) 143,143,179
143 IF ( SMAT(I,1) .LE. ACUT1 .AND. SMAT(I,1) .GE. ACUT2
1 .OR. SMAT(I,1) .LE. ACUT3 .AND. SMAT(I,1) .GE. ACUT4 ) GO TO 142
    GO TO 180
142 IF (ISMVAR .LT. 1 ) GO TO 147
    DO 145 IJ=1,ISMVAR
144 READ (NTA)
    LOC=144
    IF (IEOF) 145,145,179
145 CONTINUE
147 NUM=NUM + 1
    I=I+1
    GO TO 141
179 IEOF = C
    BACKSPACE NTA
C
C   CHECK FOR SYNTHESIZING ADDITIVE NOISE SUBROUTINE
180 IF (ISAN .EQ. 1 ) CALL SANSUB( NUM, AVGN , $190)
C
C   CHECK FOR NOISE SUBTRACTION SUBROUTINE
    IF (NSS .EQ. 2 ) CALL NSSSLB( NUM, AVGN, $190)
190 I1=1
    K=1
    AVGSIZ=0.
    AVGUTA=C.
    ICINT=C.
    II=1
200 IF (SMAT(I1,1) .GE. 0.0 ) GO TO 205
    I1=I1+1
    K=I1
    IF (K .GT. NUM) GO TO 290
    GO TO 200
205 DO 210 IJ=2,6
    IF (M1(IJ) .EQ. 0) GO TO 210
    EE1(IJ) = SMAT(K,IJ) - E1(IJ)

```

```

      EE2(IJ) = SMAT(K,IJ) + E1(IJ)
210 CONTINUE
220 ICONT=ICONT+1
      E(ICONT)= SMAT(K,1)
      SMAT(K,1) = -SMAT(K,1)
      K=K+1
      IF (K .GT. NUM ) GO TO 245
227 DO 230 IJ=2,6
      IF(M1(IJ) .EQ. 0 ) GO TO 230
      IF ( SMAT(K,1) .LT. 0.0 .OR. (SMAT(K,IJ) .LT. E1(IJ) .OR.
      SMAT(K,IJ) .GT. EE2(IJ))) GO TO 232
230 CONTINUE
      GO TO 220
232 K=K+1
      IF ( K .LE. NUM ) GO TO 227
245 IF (ICONT .EQ. 0) GO TO 250
250 DICONT=ICONT
      DNUM=NUM
      CCS=DICONT/DNUM
      AVGSIZ= CCS + AVGSIZ
      DAXM=0.
      DO 260 I=1,ICONT
      DO 260 IJ=1,ICONT
      IF ( DAXM .LT. AMOD(ABS(E(I) - E(IJ)),180.)) DAXM=AMOD(ABS(E(I) -
      E(IJ)),180.)
260 CCNTINUE
      DK      =DAXM /DNORMA
      AVGDIA= DK  + AVGDIA
      AP(II)=1./ 3.0  *(CCS**2 + DK**2 )
      WRITE(6,1001) II,CCS,II,DK
      IF (IDPT .NE. 1) GO TO 270
      WRITE(6,1003) (E(IJ),IJ=1,ICONT)
270 II= II+1
      II=II+1
      ICONT=0
      K=II
      IF (II .LE. NUM ) GO TO 200
290 AA=0.
      ICN=II-1
      DCN=ICN
      ENNOEC=1.-DCN/FLOAT(NUM)
      DO 300 IJ=1,ICN
      AP(IJ)=SQRT(1./3. *(ENNOEC**2) +AP(IJ))
300 AA=1./(DCN )*AP(IJ)+AA
      AVGSIZ= AVGSIZ /DCN
      AVGDIA= AVGDIA /DCN
      DA=0.
      DO 310 IJ=1,ICN
310 DA= (1./DCN*(AP(IJ)-AA)**2) +DA
      DA=SQRT(DA)
      WRITE(6,1011) (AP(I),I=1,ICN)
      WRITE(6,1004) AA,DA,ENNOEC
      WRITE(6,1013) AVGSIZ , AVGDIA, NUM
      NO11=NU
1000 FORMAT(12,2X5E10.4,3X14)
1001 FURMAT(1X4H C(S 14,2H)= F10.4,5X4H D(S 14,2H)= F10.4 )

```

```

1002 FORMAT(31H SCATTERING MATRIX DATA NUMBER 14,23H DOESN'T EXIST ON
1TAPE )
1003 FORMAT(47H AZIMUTH VALUES IN THIS EQUIVALENCE CLASS ARE /(5F6.1))
1004 FORMAT(1X5HAVGA=F9.4,5HVARA= F10.4,8H 1-K/N= F8.4)
1005 FORMAT(8A5)
1006 FORMAT( 1X 4CH SMUS - STATISTICAL SIGNATURE AMBIGUITY /
1 1X 16H SIGNATURE TYPE A5 /
2 1X 16H SM TAPE NUMBER A5, 14H MODEL NUMBER A5 /
3 1X 6H S/N= A5 ,3H DB /
4 1X 5H SAN= A5 ,5X6F AVGN= A5 /
5 1X 20H NOISE SUBTRACTION= A5 /
6 1X 18H ERROR LIMITS ARE /
71X6H E(1)=F6.3,6H E(2)=F6.3,6H E(3)=F6.3,6H E(4)=F6.1,6H E(5)=F6.1
8/ 1X7H ACUT1= F6.1,7H ACUT2= F6.1,7H ACUT3= F6.1,7H ACUT4= F6.1 /
91X 8H ISMVAR= I2 )
1008 FORMAT(I3)
1009 FORMAT(1X14)
1010 FORMAT(6F10.3)
1011 FORMAT( 28H NORMALIZED AMBIGUITY VECTOR / (5F10.4))
GO TO 20
550 WRITE(6,1012) LOC
1012 FORMAT( 32H END OF FILE ERROR AT STATEMENT 14 )
1013 FORMAT (1X, 8HAVGSIZ =,F6.4,10H AVGDIA =,F6.4, 7H NUM =,I4)
GO TO 20
END

```

```

SUBROUTINE SANSUB(NUM,AVGN ,*)

```

C  
C  
C

```

SUBROUTINE FOR SYNTHESIZING ADDITIVE NOISE

```

```

COMMON

```

```

✓1/AA1/SMAT(3700,6) M1(6), ACUT1, ACUT2,
2 ACUT3, ACUT4
DO 50 I=1,NUM
DO 50 J=2,4
EIJ= 10.*ALOG10(1. + 10.**((AVGN -SMAT(I,J))/10. ) )
SMAT(I,J) = SMAT(I,J) +EIJ
50 CONTINUE
RETURN 1
END

```

```

SUBROUTINE NSSUB(NUM, AVGN,*)

```

C  
C  
C

```

NOISE SLETRACTION SUBROUTINE

```

```

COMMON

```

```

✓1/AA1/SMAT(3700,6) M1(6), ACUT1, ACUT2,
2 ACUT3, ACUT4
DO 50 I=1,NUM
DO 50 J=2,4
IF (SMAT(I,J) - AVGN .GT. C.(433 ) GO TO 40
SMAT(I,J) = AVGN - 20.C
GO TO 50
40 SMAT(I,J) = AVGN + 10.* ALOG10 ( 10. **((SMAT(I,J) -AVGN)*.1)-1.)
50 CONTINUE
RETURN 1
END

```

## Enclosure (C)

### H65 - Sample Problem

#### 1. Description

Three sample problems are included. Each of these problems utilizes a reduced signature set in order to minimize the time required to check out the program. This time may be further shortened by increasing the values of ACUT2 and/or ISMVAR.

Problem 1 uses the first file on the library tape and does not use either subroutine.

Problem 2 uses the first file on the library tape and incorporates the Noise Subtraction Subroutine. The value of -15.0 dBsm for average noise is artificial and is chosen so that the effect of noise subtraction on ambiguity will be obvious.

Problem 3 uses the second file on the library tape and the Synthesize Additive Noise Subroutine. The value of average noise is again chosen so that the effect of noise on ambiguity will be easily detected.

#### 2. Sample Problem Deck Listing

The following is a listing of the enclosed sample problem deck. See Enclosure (E) for an explanation of each term of this listing.

#### 3. Sample Problem Output

The following is a listing of the output of procedure H65 for the three sample problems. The time required to run these three problems in sequence on the IBM 7090 using a binary source deck is 0.72 minutes.

#### 4. Sample Problem Deck

(the reverse of this page is blank)



## Enclosure (C)

### 3. Sample Problem Output

9 175529 C 0627200            GRIIVER G            04117 0825 465 250079

90 UNIT	RD	PU	PR	A1	A2	A3	A4	A5	A6
FUNCTION	CRD	PCH	PRT	LB1	IV1	OUI	PP1	CK1	LB3
SYMBOLIC									
40 LOGICAL	32	33	34	00	01	02	03	04	05
40 UNIT	DISK	DISK	DISK	DISK	DISK	DISK	DISK	DISK	DISK
90 UNIT	B8	B9	B0	C1	C2	C3	C4	C5	C6
FUNCTION									
SYMBOLIC									
40 LOGICAL	17	18	19	20	21	22	23	24	25
40 UNIT	DISK	DISK	DISK	DISK	DISK	DISK	DISK	DISK	DISK

9 175529 C \$SETUP 09            09  
9 175529 C \$EXECUTE            I8JOB  
9 175552 C EXECUTION  
9 175611 C THIS JOB IS COMPLETE.

9 175611 C     142 LINES OUTPUT.  
9 175611 C \$IBSYS  
9 175611 C \$STOP

062079 02

A7	A8	A9	A0	B1	B2	B3	B4	B5	B6	B7
				UT1	UT2	UT3	UT4	CK2	LB4	
9										
06	07	08	09	10	11	12	13	14	15	16
C1	DISK	DISK	DISK	DISK	DISK	DISK	DISK	DISK	DISK	DISK
01	02	03	04	05	06					
26	27	28	29	30	31					
DISK	DISK	DISK	DISK	DISK	DISK					

IBJOB VERSION 5 HAS CONTRDI.  
\$IBJOB NOSOURCE

(the reverse of this page is blank)

GENERAL DYNAMICS  
FORT WORTH DIVISION

7090 PROCEDURE H65  
PROBLEM 062079-001

SMUS - STATISTICAL SIGNATURE AMBIGUITY

SIGNATURE TYPE SM

SM TAPE NUMBER 64D11 MODEL NUMBER 3

S/N= 72 DB

SAN= NO AVGN= -65

NOISE SUBTRACTION= NO

ERROR LIMITS ARE

E(1)= 1.010 E(2)= 1.010 E(3)= 1.010 E(4)= 10.0 E(5)= 10.0

ACUT1= 180.0 ACUT2= 160.0 ACUT3= 160.0 ACUT4= 160.0

ISMVAR= 2

CIS 1)=	0.0741	D(S 1)=	0.0650
CIS 2)=	0.0741	D(S 2)=	0.0650
CIS 3)=	0.0741	D(S 3)=	0.0550
CIS 4)=	0.0926	D(S 4)=	0.0850
CIS 5)=	0.0185	D(S 5)=	0.
CIS 6)=	0.0741	D(S 6)=	0.0550
CIS 7)=	0.0556	D(S 7)=	0.0300
CIS 8)=	0.0556	D(S 8)=	0.0450
CIS 9)=	0.0370	D(S 9)=	0.0150
CIS 10)=	0.0370	D(S 10)=	0.0200
CIS 11)=	0.0185	D(S 11)=	0.
CIS 12)=	0.0370	D(S 12)=	0.0150
CIS 13)=	0.0370	D(S 13)=	0.0200
CIS 14)=	0.0185	D(S 14)=	0.
CIS 15)=	0.0185	D(S 15)=	0.
CIS 16)=	0.0370	D(S 16)=	0.0150
CIS 17)=	0.0370	D(S 17)=	0.0200
CIS 18)=	0.0370	D(S 18)=	0.0150
CIS 19)=	0.0370	D(S 19)=	0.0150
CIS 20)=	0.0370	D(S 20)=	0.0150
CIS 21)=	0.0370	D(S 21)=	0.0200
CIS 22)=	0.0370	D(S 22)=	0.0150
CIS 23)=	0.0185	D(S 23)=	0.

NORMALIZED AMBIGUITY VECTOR

0.3363	0.3363	0.3357	0.3393	0.3316
0.3357	0.3334	0.3340	0.3322	0.3323
0.3316	0.3322	0.3323	0.3316	0.3316
0.3322	0.3323	0.3322	0.3322	0.3322
0.3323	0.3322	0.3316		

AVGA= 0.3332 VARA= 0.0020 1-K/N= 0.5741

AVGSIZ = 0.0435 AVGDIA = 0.0254 NUM = 54

SMUS - STATISTICAL SIGNATURE AMBIGUITY

SIGNATURE TYPE SM

SM TAPE NUMBER 64D11 MODEL NUMBER 3

S/N= 72 DB

SAN= NO AVGN= -15

NOISE SUBTRACTION= YES

ERROR LIMITS ARE

E(1)= 1.010 E(2)= 1.010 E(3)= 1.010 E(4)= 10.0 F(5)= 10.0

ACUT1= 180.0 ACUT2= 160.0 ACUT3= 160.0 ACUT4= 160.0

ISMVAR= 2

C(S 1)=	0.0741	D(S 1)=	0.0650
C(S 2)=	0.0741	D(S 2)=	0.0650
C(S 3)=	0.0926	D(S 3)=	0.0750
C(S 4)=	0.0556	D(S 4)=	0.0400
C(S 5)=	0.0370	D(S 5)=	0.0200
C(S 6)=	0.0556	D(S 6)=	0.0300
C(S 7)=	0.0185	D(S 7)=	0.
C(S 8)=	0.0185	D(S 8)=	0.
C(S 9)=	0.0370	D(S 9)=	0.0150
C(S 10)=	0.0370	D(S 10)=	0.0150
C(S 11)=	0.0185	D(S 11)=	0.
C(S 12)=	0.0185	D(S 12)=	0.
C(S 13)=	0.0185	D(S 13)=	0.
C(S 14)=	0.0370	D(S 14)=	0.0200
C(S 15)=	0.0185	D(S 15)=	0.
C(S 16)=	0.0185	D(S 16)=	0.
C(S 17)=	0.0185	D(S 17)=	0.
C(S 18)=	0.0185	D(S 18)=	0.
C(S 19)=	0.0185	D(S 19)=	0.
C(S 20)=	0.0185	D(S 20)=	0.
C(S 21)=	0.0185	D(S 21)=	0.
C(S 22)=	0.0370	D(S 22)=	0.0150
C(S 23)=	0.0185	D(S 23)=	0.
C(S 24)=	0.0185	D(S 24)=	0.
C(S 25)=	0.0370	D(S 25)=	0.0150
C(S 26)=	0.0185	D(S 26)=	0.
C(S 27)=	0.0185	D(S 27)=	0.
C(S 28)=	0.0185	D(S 28)=	0.
C(S 29)=	0.0185	D(S 29)=	0.
C(S 30)=	0.0185	D(S 30)=	0.
C(S 31)=	0.0370	D(S 31)=	0.0200
C(S 32)=	0.0370	D(S 32)=	0.0200

NORMALIZED AMBIGUITY VECTOR

0.2420	0.2420	0.2451	0.2385	0.2365
0.2380	0.2355	0.2355	0.2363	0.2363
0.2355	0.2355	0.2355	0.2365	0.2355
0.2355	0.2355	0.2355	0.2355	0.2355
0.2355	0.2363	0.2355	0.2355	0.2363
0.2355	0.2355	0.2355	0.2355	0.2355
0.2365	0.2365			

AVGA= 0.2366 VARA= 0.0022 1-K/N= 0.4074

AVGSIZ =0.0312 AVGDIA =0.0130 NUM = 54

SMUS - STATISTICAL SIGNATURE AMBIGUITY

SIGNATURE TYPE SM

SM TAPE NUMBER 64011 MODEL NUMBER 3

S/N= 52 DB

SAN= YES AVGN= -15

NOISE SUBTRACTION= NO

ERROR LIMITS ARE

E(1)= 1.010 E(2)= 1.010 E(3)= 1.010 E(4)= 10.0 E(5)= 10.0

ACUT1= 180.0 ACUT2= 160.0 ACUT3= 160.0 ACUT4= 160.0

ISMVAR= 2

C(S 1)=	0.0556	D(S 1)=	0.0400
C(S 2)=	0.0556	D(S 2)=	0.0550
C(S 3)=	0.0741	D(S 3)=	0.0750
C(S 4)=	0.0926	D(S 4)=	0.0700
C(S 5)=	0.0556	D(S 5)=	0.0450
C(S 6)=	0.0556	D(S 6)=	0.0450
C(S 7)=	0.0556	D(S 7)=	0.0300
C(S 8)=	0.0741	D(S 8)=	0.0550
C(S 9)=	0.0741	D(S 9)=	0.0550
C(S 10)=	0.0556	D(S 10)=	0.0300
C(S 11)=	0.0370	D(S 11)=	0.0150
C(S 12)=	0.0556	D(S 12)=	0.0400
C(S 13)=	0.0370	D(S 13)=	0.0250
C(S 14)=	0.0370	D(S 14)=	0.0200
C(S 15)=	0.0556	D(S 15)=	0.0350
C(S 16)=	0.0556	D(S 16)=	0.0350
C(S 17)=	0.0370	D(S 17)=	0.0200
C(S 18)=	0.0370	D(S 18)=	0.0200

NORMALIZED AMBIGUITY VECTOR

0.3869	0.3875	0.3897	0.3907	0.3871
0.3871	0.3866	0.3886	0.3886	0.3866
0.3856	0.3869	0.3858	0.3857	0.3868
0.3868	0.3857	0.3857		

AVGA= 0.3871 VARA= 0.0014 I-K/N= 0.6667  
 AVGSIZ =0.0556 AVGDIA =0.0394 NUM = 54

142 LINES OUTPUT.

Enclosure (D)  
H65 LIBRARY DATA

1. DESCRIPTION

Library data for procedure H65 are described in Section II of enclosure (4). The library tapes for procedure H65 are produced from raw data by procedure H31. The library tape is written in binary mode, 7-track at a density of 800 BPI.

The following format is used:

LIBRARY TAPE FORMATS  
FILE 1 (SCATTERING MATRIX 1)

<u>RECORD NO.</u>	<u>CONTENTS</u>
1	STANDARD HEADER RECORD
2	NO (SCATTERING MATRIX ID)
3	SM1, SM2, SM3, SM5, SM4, SM6
4	SM1, SM2, SM3, SM5, SM4, SM6
⋮	⋮
⋮	SM1, SM2, SM3, SM5, SM4, SM6
⋮	STANDARD TRAILER RECORD
⋮	END OF FILE

FILE K ( SCATTERING MATRIX K)

<u>RECORD NO.</u>	<u>CONTENTS</u>
1	STANDARD HEADER RECORD
2	NO (SCATTERING MATRIX ID)
3	SM1, SM2, SM3, SM5, SM4, SM6
4	⋮
⋮	⋮
⋮	SM1, SM2, SM3, SM5, SM4, SM6
⋮	STANDARD TRAILER RECORD
⋮	END OF FILE

LAST FILE

<u>RECORD NO.</u>	<u>CONTENTS</u>
1	STANDARD TRAILER RECORD FOR LAST FILE ON TAPE. END OF FILE

DESCRIPTION

Here SM1 represents azimuth angle, SM2, SM3, and SM5 represent cross section in dbm, while SM4 and SM6 represent phase.

The phase terms represent relative phase where  $SM4 = \theta_{12} - \theta_{11}$  and  $SM6 = \theta_{22} - \theta_{11}$ .

LIBRARY TRACK  
TO C / QUALIFYING MATRIX

CONTENTS

RECORD NO.

STANDARD HEADER RECORD  
NO QUALIFYING MATRIX IN  
SM1, SM2, SM3, SM4, SM5, SM6

1  
2  
3

SM1, SM2, SM3, SM4, SM5, SM6  
STANDARD TRAILER RECORD  
END OF FILE

TO C / QUALIFYING MATRIX K1

CONTENTS

RECORD NO.

STANDARD HEADER RECORD  
NO QUALIFYING MATRIX IN  
SM1, SM2, SM3, SM4, SM5, SM6

1  
2  
3

SM1, SM2, SM3, SM4, SM5, SM6  
STANDARD TRAILER RECORD  
END OF FILE

LAST FILE

CONTENTS

RECORD NO.

STANDARD TRAILER RECORD  
END OF FILE

1

101

Enclosure (E) H65-Customer Utilization

INSTRUCTIONS TO CUSTOMER

IBM 7090 PROCEDURE H65

I. PROCEDURE PURPOSE

The primary function of this procedure is the computation of a normalized ambiguity vector which serves as a measure of the ambiguity or uncertainty of different types of signature representations of a scattering vehicle.

II. INPUT DATA

A. Library Data

Library tapes are identified by a label of the form XXXXXXDNN where XXXXXX is the job number under which the tape is produced, D is an alphabetic character, and NN is a sequence number.

Only one library tape may be input per job and it must be listed on the job sheet under Library Input. Library tapes for this procedure are produced by 7090 procedure H31.

**B. Problem Data**

**1. Identification Format**

Columns

63-68	Job number (assigned by the Digital Computing Lab).
69	"p"
70-72	Deck number
73-77	Card sequence number
78-80	"H65"

The card sequence number must begin with 00001 for each deck and cards must be numbered sequentially.

**2. Symbols Used**

NO	Scattering matrix I.D. number on tape.
ISAN	=1 Subroutine for synthesizing additive noise on signature set =0 Subroutine won't be used.
NSS	=2 Noise subtraction subroutine will be used. =0 Subroutine won't be used.

**AVGN** Average noise used in the Noise Subtraction and Synthesize Additive Noise Subroutines.

**M1(J)** Determines signature type to be considered where  $J = 2, 3, 4, 5, 6$ .  
 If  $M1(J) = 1$  Column is considered  
 If  $M1(J) = 0$  Column isn't considered

**ISMVAR**  $ISMVAR = N$ ,  $N$  azimuth values will be skipped between each azimuth reading.  
 If the number of azimuth recordings for a given signature set exceeds 2250, then  $ISMVAR$  must be greater than zero.

**ACUT1** Value for upper azimuth bound for first interval  $180.0^{\circ} - 0.0^{\circ}$ .

**ACUT2** Value for lower azimuth bound for interval  $180.0^{\circ} - 0.0^{\circ}$ .

**ACUT3** Value for upper azimuth bound for interval  $360.0^{\circ} - 180.0^{\circ}$ .

**ACUT4** Value for lower azimuth bound for interval  $360.0^{\circ} - 180.0^{\circ}$ .  
 If the azimuth values between  $360^{\circ} - 180^{\circ}$  are not desired, set  $ACUT2 = ACUT4$ .

ACUT1 must be greater than or equal to the first value on tape approximately  $180.0^{\circ}$  for a given scattering matrix file. The value of ACUT4 must be greater than that of ACUT1.

If azimuth values between  $360^{\circ} - 180^{\circ}$  are desired and ISMVAR is greater than zero, then ACUT4 must be at least ISMVAR - N records from the END OF FILE on the particular scattering matrix file being used.

IOPT =1 for printout of azimuth angles.

=0 to suppress printing of the azimuth angles.

E1(J) Determines the error associated with each azimuth recording on tape. E1(2), E1(3), and E1(4) are associated with the three amplitude recordings for VV, VH, and HH data, E1(5) and E1(6) are associated with the two phase recordings.

DNORMA Normalization factor used to normalize the magnitude of the equivalence class diameter to unity.

NNN	Signature type identification data
TN	Tape number
MN	Model number
SN	Signal to noise ratio
SAN	Identification for synthesizing additive noise
NS	Identification for noise subtraction
AVGN	Mean cross section

3. Card Formats (H65)

- a. First card of each deck containing alphameric information.

Card Cols.	1-5	6-10	11-15	16-20	21-25	26-30	31-35
Data	NNN	TN	MN	SN	SAN	NS	AVGN

Data from the first card of each deck is used as heading information and nowhere does it enter into the selection of desired options or calculations.

b.

Card Cols	1-2	5-14	15-24	25-34	35-44	45-54	60-61
D A T A	1						NO
	2		AVGN				ISAN NSS
	3	M1(2)	M1(3)	M1(4)	M1(5)	M1(6)	
	4	E1(2)	E1(3)	E1(4)	E1(5)	E1(6)	
	5	ACUT1	ACUT2	ACUT3	ACUT4	ISMVAR	
	6	IOPT					
	7	DNORMA					
	8						

All items will be zero if not input, except for ACUT1, ACUT2, ACUT3, and ACUT4, these variables assume the values of  $180^{\circ}$ ,  $0^{\circ}$ ,  $360^{\circ}$  and  $181^{\circ}$ , respectively for the first card deck if not input.

Items NO, NSS, ISAN, and data type number in columns 1-2 must be right-adjusted and written without a decimal point. All other input items must contain a decimal point and may contain an exponent (power of ten by which the number is multiplied) in the right most columns of its field. The exponent may be omitted if the last column

of the field is blank. When input, the exponent is preceded by its sign or the character E and contains no decimal point.

For optimum usage, problems using the same stored scattering matrix may be run sequentially. This allows the customer to utilize different sets of error limits as well as the existing noise subroutines. Note that once the noise subtraction or synthesizing additive noise subroutine has been used the original scattering matrix in storage will be destroyed.

### III. OUTPUT

The basic output of this program is a listing of the normalized size  $C(SI)$ , the normalized diameter  $D(SI)$ , and the magnitude of the normalized ambiguity vector for the  $I$ th equivalence class for each of the  $K$  equivalence classes. Also, the sample mean and sample variance of the  $K$  ambiguity vectors are output as is the value of one minus the normalized number of equivalence classes  $1-K/N$ . The average size and average diameter of the  $K$  equivalence classes are output.

Additionally if IOPT = 1, the values of the azimuth angles which are included in each equivalence class are printed.

#### IV.

##### TIME ESTIMATE FOR H65-AMBIGUITY PROGRAM

A single problem utilizing an SM signature and approximately 1500 signatures can be accomplished in four (4) minutes. The time required may be considerably reduced as the number of equivalence classes is reduced either by using a simpler signature type or larger error limits. It is recommended that the first problems of any set of problems consist of the most complicated signatures and lowest error limits followed by the simpler signature types and/or larger error limits. In this manner, if a time estimate is exceeded, the shorter problems will be truncated rather than the longer ones.

If ISMVAR = 1, the maximum number of signatures will be 1800. If ISMVAR = 0, the values of the ACUT parameters must be adjusted to limit the total number of signatures to less than 2250. A corresponding increase in time would be required in this case.

Enclosure (F)

H65 - Description of Changes Necessary for Compatibility  
with GE-625/635

The following changes will be necessary in order to make the H65 source deck compatible with the GE-625/635 computer.

Item No.

Change Required

- 1        On card number H65A009 replace the value of NTA on the right hand side of the equal sign with the logical file number on which the H65 library tape will be placed.  
  
          Example: NTA=9  
  
          When H65 is run on the IBM 7090, logical file #9 is used for the library tape.
  
- 2        The three cards H65A006, H65B200, and H65C215 establish the dimensions of the arrays necessary to store the input signature set as an 3700X6 array. If the available storage is less than 22,200 words after compiling, the number 3700 must be reduced accordingly. If 22,200 words are available for input data storage, an entire signature set of 3600 scattering matrices can be processed during a single problem run. Otherwise the signature set must be reduced utilizing the ACUT's and ISMVAR parameters as discussed in enclosure (E). If, for example, storage for only 15,000 words is available, the value 3700 on cards H65A006, H65B200, and H65C215 must be changed to 2500, and the values of the ACUT's and ISMVAR used to prevent overflow of storage.
  
- 3        Incorporate GE-625/635 system control cards as necessary.

ENCLOSURE (G)  
H65 - Logic Diagram

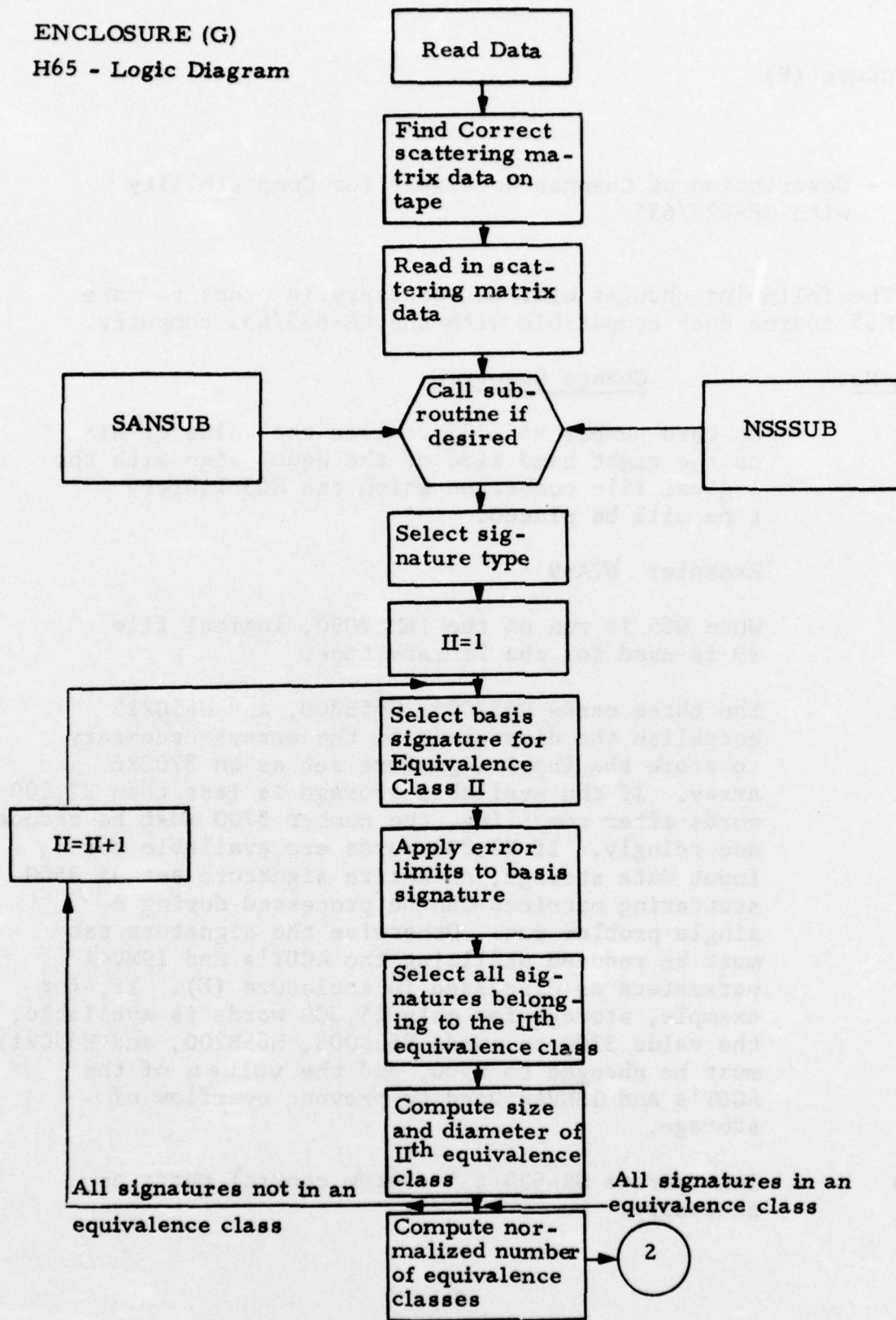

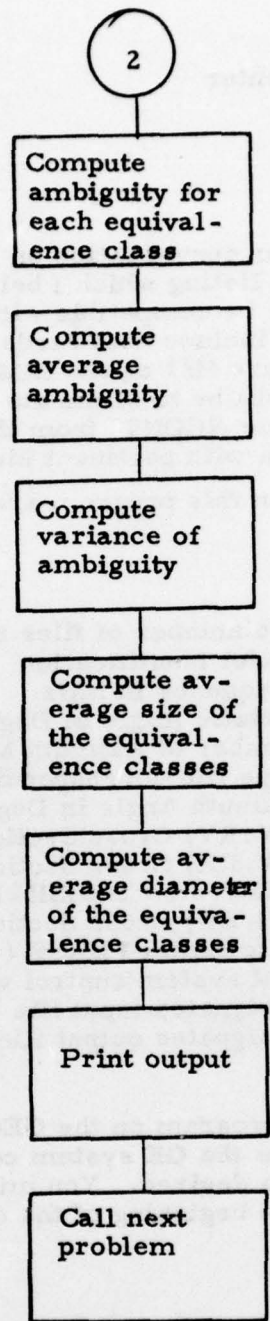

6 July 1967

Rome Air Development Center  
Griffiss Air Force Base  
Rome, New York 13440

With reference to our conversation on July 5, 1967, I am enclosing a simple computer program listing which I believe will enable you to generate a magnetic tape which will be compatible with the GE635 computer. The input to this program will include both cards and the standard SMUS library tapes produced by Procedure H31 on the IBM computer at GD/FW. The purpose of this program will be to eliminate the IBM system control words (represented by the variable NCONT) from the library tape and to provide a listing of the library data with pertinent identification data.

The variables used in this program are identified as follows:

NFILES	The number of files to be reproduced
NMOD	Model Identification
NFREQ	Frequency in MHz
ANGLE	Bistatic Angle in Degrees
N	Number of Azimuth Measurements
NO	Tape file corresponding to NMOD
SMAT(1)	Azimuth Angle in Degrees
SMAT(2)	(TV, RV) Cross Section in dBsm
SMAT(3)	(TV, RH) Cross Section in dBsm
SMAT(4)	Differential PHASE ( $\psi_{VH} - \psi_{VV}$ )
SMAT(5)	(TH, RH) Cross Section in dBsm
SMAT(6)	Differential PHASE ( $\psi_{HH} - \psi_{VV}$ )
NCONT	IBM system control word
NTA	Designates input file
NTB	Designates output file

In order to run this program on the GE635 computer, it should only be necessary to incorporate the GE system control cards and designate values for NTA and NTB as desired. You might also like to include a tape identification number at the beginning of the output listing.

Note, that I have used input file 5 and output file 6 for card input and listed output, respectively. You may desire to change these numbers to conform to the GE system.

The table below indicates the required format for the card inputs.

Card Columns	1 - 6	7 - 12	13 - 18
Input Card #1	NFILES=3		
Input Card #2	NMOD=3	NFREQ	ANGLE
Input Card #3	N	3000	0

Items NFILE and N must be right-adjusted and written without a decimal point.

This program should facilitate the direct conversion from all the IBM formatted tapes produced by Procedure H31. The simplest manner of providing these data appear to be for us to send you the pertinent H31 tapes so that you can duplicate them and then return the originals to us. Any attempt to remove the effects of the control words directly in the SMUS computer programs would necessitate extensive changes in each program.

I hope this approach meets with your approval and is successful. Please contact me if additional information is desired.

Sincerely,

GENERAL DYNAMICS  
Fort Worth Division



G. W. Gruver

P.S.  $N_1 = 2853$  [180°]  
 $N_2 = 2836$  [180°]  
 $N_3 = 2732$  [180.4]

Enclosure (1)

```
10  DIMENSION SMAT (6)
    NTA = 09
    NTB = 10
    READ (5,1000) NFILES
    DO 200 K=1, NFILES
    READ (5,1001) NMOD, NFREQ, ANGLE
    READ (NTA) NCONT, (SMAT (J), J=1,6)
    WRITE (NTB) (SMAT (J), J=1,6)
    READ (NTA) NCONT, NO
    WRITE (NTB) NO
    READ (5,1000) N
1000  FORMAT (I2)
1001  FORMAT (3A6)
1005  FORMAT (I4)
    WRITE (6,1010) NMOD, NFREQ, ANGLE
    WRITE (6,1015) N, NO
1010  FORMAT (1X37HSCATTERINGbMATRIXbDATAbIDENTIFICATION//
11X13HMODELbNUMBERbA6,12HFREQUENCYb-bA6,3HMHZ,
217HBISTATICbANGLEb=bA6,7HDEGREES)
1020  FORMAT (1X39HNUMBERbOFbAZIMUTHbMEASUREMENTSb
1EQUALSbbI4,1X33HFORbSCATTERINGbMATRIXbDATAbFILEbbI4)
    M=N+1
    DO 100 I=1,M
    READ (NTA) NCONT, (SMAT (J), J=1,6)
    WRITE (NTB) (SMAT (J), J=1,6)
    WRITE (6,1030) SMAT(1), SMAT(2), SMAT(3), SMAT(5),
1SMAT(4), SMAT(6)
1030  FORMAT (6(5X,F6.1))
    100  CONTINUE
    END FILE NTB
    200  CONTINUE
    END FILE NTB
    STOP
    END
```

NOTE: b indicates blank

In developing the SPECT and DISCRM computer programs , three programs were used. These are SPECT, CLASS and TRAIN. Fortran listings for these three programs follow.

F. J. ...  
...  
...

**SECTION VIII**

SPECT

```

C          SPECT AND SPECT3
COMMON/BLOCK1/CKSAT(361), CKITH(4,361),LAST,IVARRP,THOLD,IRO,DRANG
1, IRS , IA , IRSTRT , ICTRL , VSTD , ITH, CONST , SAT , IMODE ,
2 SIGCAL , CKONE(361) , ANOISE
COMMON/BLOCK2/ NS(361) , ISR(361,10) , ISNCT(361,10) ,
1INTST(361,1) , ISPCT(361,1) , ISE(361,10) , SIG(540)
C
C          COMMON/BLOCK4/ INPN(361,3) , R(361,30) , S(361,30) ,
INPN(361) , IINPN(361,3) , RR(361,30) , SS(361,30)
COMMON /INPUT7 INDAT(360),IECF
C
C          DIMENSION THDES(361) , IDATA(540) ,
1 IFSEP(2) , HEADR(5) , TRAILR(5) ,
2 NSUB(4) ,
3 THETS(4,9) , THETE(4,9) , SIGREF(4)
4, SYSATT(4) , THMISS(30) ,
5 NVDITH(5) , VOIDL(5) , VOIDH(5)
DIMENSION CKSAT(361) , CKONE(361)
DIMENSION IPOS(361),VSTDP(361) , IRSP(361)
DIMENSION ITHETA(2) , IIA(2)
DIMENSION HEAD(5),TRAIL(8)
DIMENSION TGTID(12), POLID(3)
DIMENSION BASE(4), REFMIS(30), XAR(2), YAR(2)
5 CONTINUE
READ (5,10) TGTID , IUN , FREQ , NPOL , NBRTGT
1000 FORMAT( 12A4, 3X, I2, F5. , 4X, I1, 1X, I2 )
WRITE (6,26) TGTID, IUN, FREQ, NPOL, NBRTGT
2060 FORMAT ( 9H TARGET =,12A4, //9H IUN =,I3, /9H FREQ =,F6.2,
1 /9H NPOL =, I3 , /9H NBRTGT =,I4 )
IF ( NPOL .GT. .AND. NPOL .LE. 2 ) GO TO 6
WRITE (6,102)
1002 FORMAT (15H NPOL INCORRECT )
CALL EXIT
6 CONTINUE
READ (5,110) DRANG, TGTDIM, THINC, VSTD
1010 FORMAT( 6F10. )
WRITE(6,270) DRANG, TGTDIM, THINC, VSTD
2070 FORMAT ( 9H DRANG =,F7.3, /9H TGTDIM =,F6.2, /9H THINC =,F6.2,
1 /9H VSTD =,F6.2 )
IF ( THINC .GT. .AND. THINC .LE. 2.0 ) GO TO 11
WRITE (6,138)
1038 FORMAT (22H THINC IS NOT CORRECT )
CALL EXIT
11 CONTINUE
IF ( DRANG .GT. 0.4 .AND. DRANG .LT. 0.7 ) GO TO 7
WRITE (6,103)
1003 FORMAT (16H DRANG INCORRECT )
CALL EXIT
7 CONTINUE
THTEST = 1.*THINC

```

```

DTH = 5*THINC
HEAD (5,1 2) NFILES, NFSKP, NRPS, ICNTER, INOISE, IBIAS1, IRS
1, IIRS1, IIRS2
1020 FORMAT (2I5)
WRITE (6,2 8) NFILES, NFSKP, NRPS, ICNTER, INOISE, IRS, IBIAS1
1, IIRS1, IIRS2
2080 FORMAT (9H NFILES =,I4, /9H NFSKP =,I3,/9H NRPS =,I3,
1 /9H ICNTER =,I5, /9H INOISE =,I6,/9H IRS =,I4,
2 /9H IBIAS1 =,I5, /9H IIRS1 =,I5,/9H IIRS2 =,I5)
NUMSAM = (TGTDIM + 30.) / (2.0*DRANG)
IRO = ICNTER - (IRS + NUMSAM)
LAST = ICNTER + NUMSAM
IF (NFILES .GT. 0 .AND. NFILES .LT. 30) GO TO 8
WRITE (6,1 04)
1004 FORMAT (18H NFILES INCORRECT)
CALL EXIT
8 CONTINUE
IF (INOISE .GT. 300 .AND. INOISE .LT. 2000) GO TO 9
WRITE (6,1 05)
1005 FORMAT (23H NOISE LEVEL INCORRECT)
CALL EXIT
9 CONTINUE
IUN = 8
NWDS = 9 * NRPS
CONST1 = FLOAT(INOISE)
CONST = CONST1 + 1 00.0
ANOISE = 10.*CONST + .1
BASE(1) = (CONST1 + FLOAT(IBIAS1))/100.0
BASE(2) = (CONST1 + 2 .) / 100.0
BASE(3) = BASE(2)
BASE(4) = BASE(2)
THOLD = BASE(1)
BIAS = BASE(2)
LAST1 = LAST + 12
IIRS = IRS
THOLDA = THOLD
WRITE (6,2 19) THOLD
2019 FORMAT (9H THOLD =,F8.2)
IF (LAST .LT. (9 + IRO)) LAST = NWDS*0.9
IF (NRPS .GT. .AND.
1 NRPS .LE. 6 ) GO TO 10
WRITE (6,2 2)
2020 FORMAT (16H NRPS INCORRECT)
CALL EXIT
C
10 CONTINUE
IF (NFSKP .EQ. ) GO TO 14
READ (5,1021) (IFSJKP(J),J=1,NFSKP)
WRITE (6,203) (IFSJKP(J),J=1,NFSKP)
2030 FORMAT (25H FILES TO BE SKIPPED ARE ,/1H ,10(2X,I5) )
GO TO 15
14 IFSKP(1) =

```

```

15 CONTINUE
C
C
      JMISS =
      IFILE = 1
      ISKP  = 1
      ID = NBRTGT*10 + 1
      IIRS  = 1
      KMISS =
      WRITE (5,8810) TGTID ,FREQ ,NPOL ,NBRTGT ,ID
      WRITE(43,8810) TGTID ,FREQ ,NPOL ,NBRTGT ,ID
8810 FORMAT( 12A4,F7.2,I5,I6,          7H          F ,I6)
C*****          *****          *****
      DO 700 IP=1,NPOL
C
      READ (5,1030) POLID, NVOID
1030 FORMAT ( 3A4,2X,I4)
      IF (NVOID .LT. 5)          GO TO 16
      CALL EXIT
      16 IF (NVOID .EQ. 0)          GO TO 19
      READ (5,1035) ( VOIDL(I),VOIDH(I), I = 1,NVOID)
1035 FORMAT ( 10F6. )
      19 CONTINUE
      READ (5,1040) NATPOL,IDLPOS
1040 FORMAT ( 4X,I1,2X,I3 )
      IABPOS =IABS(IDLPOS)
      IF( NATPOL .GT. ) GO TO 20
      WRITE (6,2040)
2040 FORMAT (38H NO. OF ATTENUATIONS/POLARIZATION = )
      CALL EXIT
C
      20 READ (5,1050) (SYSATT(J),NSUB(J),SIGREF(J) , J=1,NATPOL)
1050 FORMAT ( 4(F5. ,4X,I1,P5. ) )
C
C
      DO 25 J=1,NATPOL
      IF( NSUB(J) .GT. 0 ) GO TO 25
      WRITE (6,2045)
2045 FORMAT (16H NSUB INCORRECT )
      CALL EXIT
      25 CONTINUE
C
      DO 30 IP=1,NATPOL
      L = NSUB(IP)
      READ (5,1010) ( THETS(I,J), THETE(I,J), J=1,L )
      30 CONTINUE
      WRITE (6,2050) POLID
2050 FORMAT (25H INPUT DATA PERTINENT TO ,3A4,14H POLARIZATION )
      WRITE (6,2051) NATPOL
2051 FORMAT (25H NUMBER OF ATTENUATIONS =, I5 )
      WRITE (6,2052) (SYSATT(J),NSUB(J),SIGREF(J) , J=1,NATPOL)
2052 FORMAT (4 H SYSTEM NUMBER OF REFERENCE .

```

```

1/      4 H ATTENUATION SUBINTERVALS X SECTION
2/      (1X,F6.1,10X,I1,1 X,F6.2)
3)
WRITE (6,2053)
2053 FORMAT (30H CONTROL DATA FOR ASPECT MERGING...
1/      4 H ATTENUATION INTERVAL START STOP
2/      4 H LEVEL ANGLE ANGLE )
DO 4 I=1,NATPOL
L = NSUB(I)
DO 4 J=1,L
IF( J .GT. 1 ) GO TO 35
WRITE (6,2054) I,J,THETS(I,J),THETE(I,J)
2054 FORMAT( 6X,I1,10X,I1,7X,F6.1,4X,F6.1 )
GO TO 4
35 WRITE (6,2055) J,THETS(I,J),THETE(I,J)
2055 FORMAT( 17X,I1,7X,F6.1,4X,F6.1 )
40 CONTINUE

C
TINY = THETS(1,1)
BIG = THETE(1,NSUB(1))
IF( NATPOL .EQ. 1 ) GO TO 33
DO 32 IA=2,NATPOL
IF( THETS(IA,1) .LT. TINY ) TINY = THETS(IA,1)
32 IF( THETE(IA,NSUB(IA)) .GT. BIG ) BIG = THETE(IA,NSUB(IA))
33 CONTINUE

C
J = 1
THDES(1) = TINY
200 J = J + 1
THDES(J) = THDES(J-1) + THINC
IF ( THDES(J) .LT. BIG ) GO TO 200
NDTH = J

C
DO 205 J=1,NDTH
DO 2 IA=1,NATPOL
205 CKITH(IA,J) = .
DO 21 J=1,NDTH
CKSAT(J) = .
CKONE(J) = .
IPOS(J) = IRS
NS(J) = 1
210 NFN(J) = .
DO 211 JK = 1,NDTH
VSTEP(JK) = .
IRSP (JK) = .
211 CONTINUE
JTHSRP =
IF( THDES(1) .EQ. THETS(1,1) ) GO TO 203
J =
201 J = J + 1
IF( THDES(J) .EQ. THETS(1,1) ) GO TO 202
CKITH(1,J) = 1.

```

```
CKONE(J) = 1.  
CKSAT(J) = -1.  
GO TO 201
```

```
202 JTHSRT = J - 1
```

```
203 CONTINUE
```

```
IF( THDES(NDTH) .EQ. THETE(1,NSUB(1)) ) GO TO 207  
J =
```

```
204 J = J + 1
```

```
IF( THDES(J) .LT. THETE(1,NSUB(1)) ) GO TO 204
```

```
205 J = J + 1
```

```
CKITH(1,J) = 1.
```

```
CKSAT(J) = -1.
```

```
CKONE(J) = 1.
```

```
IF( J .LT. NDTH ) GO TO 206
```

```
207 CONTINUE
```

```
NUMVD =
```

```
IF( NVOID .EQ. 0 ) GO TO 121
```

```
DO 1 I = 1, NVOID
```

```
100 NUMVD = FLOAT(NUMVD) + (VOIDH(I)-VOIDL(I))/THINC - .6
```

```
121 NASP = NDTH / NUMVD
```

```
IF( NSUB(1) .EQ. 1 ) GO TO 240
```

```
C
```

```
L = 0
```

```
NSUB1 = NSUB(1)
```

```
DO 23 J = 2, NSUB1
```

```
TEST = THETS(1,J-1)
```

```
215 L = L + 1
```

```
IF( ABS( TEST - THDES(L) ) .GT. 0.1 ) GO TO 215
```

```
JJ1 = L + 1
```

```
TEST = THETS(1, J )
```

```
220 L = L + 1
```

```
IF( ABS( TEST - THDES(L) ) .GT. 0.1 ) GO TO 220
```

```
JJ2 = L - 1
```

```
C
```

```
DO 225 II=JJ1, JJ2
```

```
CKITH(1,II) = 1.
```

```
CKONE(II) = 1.
```

```
225 CKSAT( II ) = -1.
```

```
230 CONTINUE
```

```
C
```

```
240 CONTINUE
```

```
DO 242 II = 1, NDTH
```

```
CCKONE(II) = CKONE(II)
```

```
CCKSAT(II) = CKSAT(II)
```

```
243 CONTINUE
```

```
IA = 1
```

```
ICTRL = 1
```

```
IOFT = 1
```

```
IMISS =
```

```
INT = 1
```

```
NN =
```

```
ITH = JTHSRT
```

```

IF( THDES( 1 ) .GT. 34 .AND. IA .EQ. 1 .AND. INT .EQ. 1 ) GO TO 241
GO TO 242
241 WRITE (6,19 )
1900 FORMAT (85H A STARTING ANGLE GREATER THAN 340 DEGREES FOR IA=1 AND
1INT=1 CANNOT BE ACCOMODATED )
CALL EXIT
242 CONTINUE
CALL FLGERR ( IUN, IERR )
IERR =
245 THFIN = THETE(IA,INT)
ISPTST =
SIGNUM = SIGREF(IA) + SYSATT(IA)
C
250 IF( IFILE .NE. IFSKP(ISKP) ) GO TO 270
WRITE (6,6006)
6006 FORMAT (17H FILE TEST START )
251 CONTINUE
C
CALL DATAIN
IF (IEOF) 255,252,255
252 IF (IERR) 26,251,26
C
260 WRITE (6,7001) IFILE
7001 FORMAT (26H I/O ERROR BYPASSING FILE ,I5)
IERR =
GO TO 251
C
255 WRITE (6,7000) IFILE
IEOF =
7000 FORMAT (15H BYPASSED FILE , I5 )
265 IFILE = IFILE + 1
IF( ISKP .GE. NFSKP ) GO TO 270
ISKP = ISKP + 1
GO TO 25
C
270 CONTINUE
WRITE (6,6007)
6007 FORMAT (30H FILE TEST END - FILE PROCESS BEGIN )
C
IPASS = 1
ICER =
IGN =
275 ITH = ITH + 1
C
278 ISRT = 1
IHD = 3
280 CONTINUE
292 ISPT = ISPT + 89
IF( ISRT .EQ. 91 ) IHD = 1
IF( ISRT .EQ. 181 ) IHD = 2
C

```

```

C
GO TO (281,281,290),IHD
281 CONTINUE
CALL DATIN
DECODE(INDAT( ),4000)(HEADR(J),J=1,5)
4000 FORMAT(5A4)
JK = 1
DO 199 J = ISRT,ISTP,3
DECODE(INDAT(JK),401 ) IDATA(J)
4010 FORMAT(17X,I5)
JK = JK+3
DECODE(INDAT(JK),4020) IDATA(J+1)
4020 FORMAT(19X,I5)
JK = JK + 4
DECODE(INDAT(JK),4030) IDATA(J+2)
4030 FORMAT(15X,I5)
199 JK = JK + 3
DECODE(INDAT(304),4040) IIA(IHD),(TRAILR(J),J=1,5),ITHETA(IHD)
4040 FORMAT(5X,I3,4A4,A1,I7,2X)
IF (IEOF) 310,282,31
282 IF (IERR) 315,3 0,315
290 CONTINUE
CALL DATIN
DECODE(INDAT( ),4000) (HEAD(J),J=1,5)
JK = 1
DO 4050 J = ISRT,ISTP,3
DECODE(INDAT(JK),401 ) IDATA(J)
JK = JK + 3
DECODE(INDAT(JK),4020) IDATA(J+1)
JK = JK + 4
DECODE(INDAT(JK),4030) IDATA(J+2)
4050 JK = JK + 3
DECODE(INDAT(304),4060)(TRAIL(J),J=1,8)
4060 FORMAT(4X,8A4)
IF (IEOF) 310,291,31
291 IF (IERR) 315,3 0,315
C
300 IF( ISTOP .GE. NWDS ) GO TO 320
ISRT = ISPT + 90
IHD = 3
GO TO 28
C
C
70 CONTINUE
74 CONTINUE
C
C
310 WRITE (6,70 2) IFILE
IEOF =
7002 FORMAT (3 H OPILL ASSUMED AT END OF FILE (,I2,45H)...REPLACE DATA
STARTING WITH RESTART ANGLE )
IF ( ( THFIN - THDES(ITH) ) .LE. THINC ) GO TO 96

```

```

IOFT = 2
IFILE = IFILE + 1
GO TO 278
96 WRITE ( 6,534 ) IFILE
5340 FORMAT ( 6H FILE , I3 ,21H IS ASSUMED COMPLETE )
GO TO 411

```

```

C
C
315 CONTINUE
GO TO ( 151,152,152 ) , IND
151 ITHETA(IND) = ITHETA(IND) + THTEST
152 WRITE (6,703) IFILE , ITHETA(1)
7003 FORMAT (32H ERROR ATTEMPTING TO READ FILE ( ,I2,12H ), ASPECT = ,
1 IERR = 0
CALL EXIT

```

```

C
C
320 CONTINUE
IGN = 0
ABSITH = ITHETA(1) - ITHETA(2)
IF ( ABS(ABSITH) .GT. THTEST ) GO TO 120
119 THETA = FLOAT(ITHETA(1)) / 10.0
GO TO 13
120 IF( ITH .EQ. 1 ) GO TO 119
T1 = FLOAT(ITHETA(1)) / 10.0
T2 = FLOAT(ITHETA(2)) / 10.0
D1 = ABS( THETA - T1 )
D2 = ABS( THETA - T2 )
IF( D1 .LT. D2 ) GO TO 125
THETA = T2
GO TO 13
125 THETA = T1
130 CONTINUE

```

```

C
ISPTST = ISPTST + 1
IF ( ISPTST .NE. 2 ) GO TO 319
IF ( SYSATT(IA) .EQ. FLOAT(IIA(1))/10.0 .OR.
1 SYSATT(IA) .EQ. FLOAT(IIA(2))/10.0 ) GO TO 319
WRITE (6,6015) SYSATT(IA), IFILE
6015 FORMAT (5 H ***** ATTENUATION LEVEL OF TAPE WAS NOT EQUAL TO ,
1 F8.2, 18H FILE NO. = , I5 )
CALL EXIT
319 CONTINUE
IF ( IA .GT. 1 .OR. IP .GT. 1 .OR. INT .GT. 1 ) GO TO 317
IF ( ISPTST .GT. 1 ) GO TO 317
IMODE = 1
IF ( IDATA(9) .LT. ) IMODE = 2
IF ( IMODE .EQ. 1 ) VSTD = FUNC(VSTD,CONST)
IF ( IMODE .EQ. 2 ) GO TO 285
SAT = 99.98
IF ( THOLD .LT. 7.0 .OR. THOLD .GT. 30.0 ) GO TO 284

```

```

GO TO 317
284 WRITE (6,61) THOLD
6100 FORMAT (47H *** TAPE IN VOLTAGE .... THRESHOLD IMPROPER = , F7.2 )
CALL EXIT
285 SAT = -1.2
IF ( THOLD .GT. -15. .OR. THOLD .LT. -25.0) GO TO 286
GO TO 317
286 WRITE (6,615) THOLD
6150 FORMAT (42H *** TAPE IN DE .... THRESHOLD IMPROPER = , F7.2)
CALL EXIT
317 CONTINUE
GO TO (324,321),IOFT
321 IOFT = 1
IF ( SYSATT(IA) .EQ. FLOAT(IIA(1))/10.0 .OR.
1  SYSATT(IA) .EQ. FLOAT(IIA(2))/10.0 ) GO TO 90
WRITE (6,6015) SYSATT(IA), IFILE
CALL EXIT
900 CONTINUE
ITH = ITH - 1
TEST = THETA
J =
322 J = J + 1
IF( ABS( THDES(J) - ABS(THETA) ) .GT. DTH ) GO TO 322
NN = NN - (ITH-J) - 1
C
IF (J .LE. ITH) GO TO 326
IF ( (J-ITH) .LT. 2) GO TO 328
L1 = ITH + 1
L2 = J - 1
DO 327 L = L1,L2
CKONE(L) = 1.0
327 CONTINUE
GO TO 328
326 CONTINUE
DO 323 L = J,ITH
NPN(L) =
CKSAT(L) = CCKSAT(L)
CKONE(L) = CCKONE(L)
323 CONTINUE
328 CONTINUE
C
C
ITH =
GO TO 34
C
324 GO TO (325,330),IPASS
325 IF( THETA .GT. 340. ) THETA = THETA - 360.
IF( THETA .GE. 0. ) GO TO 330
IF( ABS(THETA) .GE. THINC ) GO TO 278
330 IF( ABS(THDES(ITH) - ABS(THETA) ) .LE. DTH ) GO TO 34
IF ( THETA .LT. THDES(ITH) ) GO TO 335
WRITE (6,701) THDES(ITH)

```

```

7010 FORMAT (14H ASPECT ANGLE ,F6.1, 9H MISSING )
      IMISS = IMISS + 1
      JMISS = JMISS + 1
      THMISS(JMISS) = THDES(ITH)
      IF( IMISS .LT. 5 ) GO TO 331
      WRITE (6,70,11)
7011 FORMAT (32H TOO MANY ASPECT ANGLES MISSING )
      CALL EXIT
331 CONTINUE
      IF( THDES(ITH) .GE. THFIN ) GO TO 400
      ITH = ITH + 1
      GO TO 331

C
335 IF ( IPASS .EQ. 2 ) GO TO 278
      GO TO 351
340 IPASS = 2
      CKITH(IA,ITH) = 1.
      NN = NN + 1

C
      WRITE (6,7020) NN, ITH, (HEADR(J), J=1,5), IIA(1), (TRAILR(J), J=1,4),
      TRAILR(5), ITHETA(1)
7020 FORMAT ( 7H SWEEP(,I3, 9H), THDES(,I3,3H) ,5A4,3X,I3,4A4,A1,I7)
350 CONTINUE
      IMISS =
      GO TO (278,355), IPASS

C
355 IF( IA .EQ. 1 ) GO TO 365
      IF( CKSAT(ITH) ) 365, 356, 370
356 L = IA -
      ISUM = 0
      DO 36 JJ=1, L
360 ISUM = FLOAT(ISUM) + CKITH(JJ, ITH) + 0.6
      IF( ISUM .EQ. L ) GO TO 365
      CKSAT(ITH) = -1.
      CKONE(ITH) = 1.

C
365 CONTINUE
      DO 366 IJ = 1, LAST1
366 SIG(IJ) = FLOAT(IDATA(IJ))/100.0

C
C
374 CONTINUE
      CALL SUBIRS ( SIG , IRSS , VSTDD , IIRS1, IIRS2 )
      IF ( VSTDD .GT. BIAS ) GO TO 372
373 CONTINUE
      CALL SUBIRS ( SIG, IRSS, VSTDD, IIRS0, IIRS1 )
      IF (VSTDD .GT. BIAS) GO TO 382
      GO TO 383
372 IF (IMODE .EQ. 1) VSTDD = FUNC(VSTDD, CONST)
      IF (NN .EQ. 1) GO TO 381
      IF ((VSTD-VSTDD) .GT. 3.) GO TO 373
      GO TO 381

```

```

382 IF (IMODE .EQ. 1) VSTDD = FUNC(VSTDD,CONST)
   IF (NN .EQ. 1) GO TO 383
   IF ((VSTD-VSTDD) .GT. 3.) GO TO 383
381 CONTINUE
   VSTD = VSTDD
   IRS = IRSS
   GO TO 364
383 CONTINUE
   KMISS = KMISS + 1
   RFFMIS(KMISS) = THDES(ITH)
384 CONTINUE
C
   VSTDP(ITH) = VSTD
   IRSP(ITH) = IRS
   IVARRF =
   SIGCAL = SIGNUM - VSTD
   IF (IA .EQ. 1) GO TO 367
   IDLTST = IABS(IPOS(ITH)-IRS) - IABPOS
   IF (IDLTST .LE. IABPOS) GO TO 369
   IRSTRT = IRS + IRO - IDLPOS
   IVARRF = IDLPOS
   GO TO 368
369 IRSTRT = 2*IRS + IRO - IPOS(ITH)
   IVARRF = IRS - IPOS(ITH)
   GO TO 368
367 CONTINUE
   IPOS(ITH) = IRS
   IRSTRT = IRS + IRO
   IF (ITH.GT. 1) GO TO 368
   IF (IMODE .EQ. 1) THOLDA = FUNC(THOLD,CONST)
   THDSM = THOLDA + SIGCAL
368 WRITE (6,90) VSTD, IRS, CKSAT(ITH), CKITH(IA,ITH), CKONE(ITH)
9000 FORMAT (7H VSTD =,F7.2,26H DB      POSITION OF REF. =,I3,5X,7HCKSAT
   =,F5.1,5X,7HCKITH =,F5.1,5X,7HCKONE =,F5.1)
   IRS = IRS - IVARRF
   RRWRT = (IRSTRT - IRS)*DRANG
   WRITE (6,90) IRSTRT, RRWRT, (SIG(J),J=IRSTRT, LAST)
9001 FORMAT (27H RECORD DATA FROM IRSTRT = , I3,
   / 2H =,F6.1,26H IN. REFERENCED TO DIFOLF . / . (20F6.2) )
   WRITE (6,90) ICTRL
9002 FORMAT (37H ***** SPECT3 ENTRY ***** ICTRL = , I2 )
   CALL SPECT3
   IRS = IRS + IVARRF
   IF (CKONE(ITH) .EQ. 1.0) CKONE(ITH) = 0.0
   WRITE (6,90) NPN(ITH), NS(ITH)
9008 FORMAT (37H ***** SPECT3 EXIT ***** NPN = , I2,5X,11HNSATT NOW =,
   A I2 )
   IF (NPN(ITH) .EQ. 0) GO TO 371
   JJ1 = NPN(ITH)
   WRITE (6,90) (INPN(ITH, KK), R(ITH, KK), S(ITH, KK), KK=1, JJ1 )
9010 FORMAT (1X,5(I1,F6.1,F5.1,1X)/(1X,5(I1,F6.1,F5.1,1X) ) )
371 CONTINUE

```

```

      IF( NS(ITH) .LT. 1 ) CKSAT(ITH) = 1.
C
370 CONTINUE
      IF( THDES(ITH) .LT. THFIN ) GO TO 275
C
C
400 CONTINUE
      WRITE (6,3070)
3000 FORMAT (18H FILE PROCESS END )
C
      IF ( IFILE .EQ. NFILES ) GO TO 465
410 CONTINUE
      CALL DATAIN
      IF (IEOF) 411,414,411
414 IF (IERR) 412,410,412
412 WRITE (6,7005) IFILE
7005 FORMAT (34H I/O ERROR READING TO EOF IN FILE , I5 )
      IERR = 1
      GO TO 410
C
411 CONTINUE
      WRITE (6,704) IFILE
7004 FORMAT (16H COMPLETED FILE(.I2, IH) )
      WRITE (6,302)
3002 FORMAT (30H END OF FILE - FILE TEST START )
      IFILE = IFILE + 1
420 IF( IFILE .NE. IFSKP(ISKP) ) GO TO 450
421 CONTINUE
      CALL DATAIN
      IF (IEOF) 425,422,425
422 IF (IERR) 43 ,421,43
C
420 WRITE (6,7011) IFILE
      GO TO 421
C
425 WRITE (6,7000) IFILE
C
435 IFILE = IFILE + 1
      IF( ISKP .GE. NFSKP ) GO TO 450
      ISKP = ISKP + 1
      GO TO 42
450 CONTINUE
      WRITE (6,304)
3004 FORMAT (16H FILE TEST END )
C
      IF( INT .GE. NSUB(IA) ) GO TO 455
      INT = INT + 1
      GO TO 46
C
455 CONTINUE
      WRITE (6,310) ( VSTD(JK), IRSP(JK), JK = 1, NASP )
3100 FORMAT (11H VSTD IRS , 9(11H VSTD IRS),//,(10(P6.1,I5)) )

```

```

DO 554 JK = 1, NASP
VSTDP(JK) = 0.
IRSP (JK) = 0

```

```

354 CONTINUE

```

C

```

IF (IA .GE. NATPOL) GO TO 465
INT = 1
IA = IA + 1
NN = 0
ICTRL = 2
J = 0

```

```

TEST = THETS(IA, 1)
THOLD = BASE(IA)
DO 459 KKLL = 1, NDTH
CKSAT(KKLL) = CKSAT(KKLL)
CCKONE(KKLL) = CKONE(KKLL)

```

```

459 CONTINUE

```

```

WRITE (6, 2010) THOLD
5010 FORMAT ( 8H THOLD = ,F6.2 )
GO TO 461

```

```

460 TEST = THETS(IA, INT)

```

```

J = ITH

```

```

461 J = J + 1

```

```

IF( ABS( TEST - THDES(J) ) .GT. 0.1 ) GO TO 461
ITH = J - 1
GO TO 245

```

C

```

465 CONTINUE

```

```

IF (IFILE .NE. NFILES) GO TO 467
WRITE (6, 2100) ( VSTDP(JK), IRSP(JK), JK = 1, NASP )

```

```

467 CONTINUE

```

```

THOLD = BASE(1)
WRITE (6, 2016)

```

```

3306 FORMAT (18H END OF FILE )

```

C

```

IF (JMISS .EQ. 0) GO TO 464
WRITE(6, 700) (THMISS(J), J=1, JMISS)

```

```

7000 FORMAT (///31H *****

```

```

1 /31H *****

```

```

2/41H THE FOLLOWING ASPECT ANGLES WERE MISSING //, (F10.1),

```

```

3 //31H *****

```

```

4 31H ***** // )

```

```

464 CONTINUE

```

```

IF (IF .NE. 1) GO TO 466
ID = ID + 1

```

```

WRITE (6, 8811) LAST, THDBSM, IRO, THINC, DRANG, IIRRS, ID
WRITE(43, 8811) LAST, THDBSM, IRC, THINC, DRANG, IIRRS, ID

```

```

8811 FORMAT (I6, F10.1, I10, F10.1, F10.2, I6, 14X, 7H P, I6)

```

C

```

466 ID = ID + 1

```

```

WRITE (6, 8812) POLID, NASP, THDES(1), THDES(NDTH), NVOID, ID
WRITE(43, 8812) POLID, NASP, THDES(1), THDES(NDTH), NVOID, ID

```

```

8812 FORMAT (3A4,I6,2F7.1,I4,30X,7H P,I6)
IF (NVOID.EQ.0) GO TO 491
ID = ID + 1
GO TO (492,493,494,495,496), NVOID
492 WRITE (6,750) (VOIDL(I),VOIDH(I),I=1,NVOID),ID
WRITE(43,750) (VOIDL(I),VOIDH(I),I=1,NVOID),ID
7500 FORMAT (2F6.1,54X,7H P,I6)
GO TO 491
493 WRITE (6,7510) (VOIDL(I),VOIDH(I),I=1,NVOID),ID
WRITE(43,7510) (VOIDL(I),VOIDH(I),I=1,NVOID),ID
7510 FORMAT (4F6.1,42X,7H P,I6)
GO TO 491
494 WRITE (6,7520) (VOIDL(I),VOIDH(I),I=1,NVOID),ID
WRITE(43,7520) (VOIDL(I),VOIDH(I),I=1,NVOID),ID
7520 FORMAT (6F6.1,30X,7H P,I6)
GO TO 491
495 WRITE (6,7530) (VOIDL(I),VOIDH(I),I=1,NVOID),ID
WRITE(43,7530) (VOIDL(I),VOIDH(I),I=1,NVOID),ID
7530 FORMAT (8F6.1,18X,7H P,I6)
GO TO 491
496 WRITE (6,7540) (VOIDL(I),VOIDH(I),I=1,NVOID),ID
WRITE(43,7540) (VOIDL(I),VOIDH(I),I=1,NVOID),ID
7540 FORMAT (10F6.1,6X,7H P,I6)

```

```

C
491 CONTINUE

```

```

C
RMAX = -1000.
RMIN = +1000.
ISET = 1
ITH = 1
500 ITH = ITH + 1
ECL = 1
ID = ID + 1
IF (CKSAT(ITH).GT.0) GO TO 510
IF (NVOID.EQ.0) GO TO 506
DO 5 5 J = 1,NVOID
IF (THDES(ITH).GT.VOIDL(J).AND.THDES(ITH).LT.VOIDH(J))
1GO TO 819

```

```

505 CONTINUE

```

```

506 CONTINUE

```

```

WRITE (6,8813) THDES(ITH),IP,ID
WRITE(43,8813) THDES(ITH),IP,ID
8813 FORMAT (F10.1,9X,1H0,20X,I10,16X,7H P,I6)
GO TO 81

```

```

C
809 ID = ID - 1
GO TO 81

```

```

C
510 IF (NPN(ITH).GT.1) GO TO 520
IF (NPN(ITH).EQ.0) GO TO 527
IF (INPN(ITH,1).EQ.1) GO TO 527
NEND = NPN(ITH)

```

```

ECL = 1
THT = THDES(ITH)
SS(1) = S(ITH,1)
RR(1) = R(ITH,1)
IINPN(1) = IINPN(ITH,1)
GO TO 528
527 CONTINUE
WRITE (6,8814) THDES(ITH) ,I9 ,ID
WRITE(43,8814) THDES(ITH) ,I9 ,ID
8814 FORMAT (F10.1,9X,1H1,20X,I10,16X, 7H P,I6)
GO TO 81
C
520 CONTINUE
THT = THDES(ITH)
NEND = NPN(ITH)
CALL REORG( ITH )
DO 525 III=1,NEND
R(ITH,III) = RR(III)
S(ITH,III) = SS(III)
IINPN(ITH,III) = IINPN(III)
IF( IINPN(III) .EQ. 2 ) ECL = ECL + 1
525 CONTINUE
528 CONTINUE
WRITE (6,8815) THDES(ITH) ,NEND ,ECL ,IP ,ID
WRITE(43,8815) THDES(ITH) ,NEND ,ECL ,IP ,ID
8815 FORMAT (F10.1,9X,1H1,I10,F10.1,I10,16X, 7H P,I6)
ITEST = NEND + 5
NE = 0
530 KS = NE + 1
ID = ID + 1
ITEST = ITEST - 5
IF( ITEST .GT. 5 ) GO TO 806
GO TO (81,802,83,84,85),ITEST
801 WRITE (6,88 1)( IINPN(J) ,RR(J) ,SS(J) , J=KS,NEND),ID
WRITE(43,88 1)( IINPN(J) ,RR(J) ,SS(J) , J=KS,NEND),ID
8801 FORMAT( 1X, (I1,F6.1,F5.1,1X), 52X, 7H P,I6)
GO TO 81
802 WRITE (6,88 2)( IINPN(J) ,RR(J) ,SS(J) , J=KS,NEND),ID
WRITE(43,88 2)( IINPN(J) ,RR(J) ,SS(J) , J=KS,NEND),ID
8802 FORMAT( 1X, 2(I1,F6.1,F5.1,1X), 39X, 7H P,I6)
GO TO 81
803 WRITE (6,88 3)( IINPN(J) ,RR(J) ,SS(J) , J=KS,NEND),ID
WRITE(43,88 3)( IINPN(J) ,RR(J) ,SS(J) , J=KS,NEND),ID
8803 FORMAT( 1X, 3(I1,F6.1,F5.1,1X), 26X, 7H P,I6)
GO TO 81
804 WRITE (6,88 4)( IINPN(J) ,RR(J) ,SS(J) , J=KS,NEND),ID
WRITE(43,88 4)( IINPN(J) ,RR(J) ,SS(J) , J=KS,NEND),ID
8804 FORMAT( 1X, 4(I1,F6.1,F5.1,1X), 12X, 7H P,I6)
GO TO 81
805 WRITE (6,88 5)( IINPN(J) ,RR(J) ,SS(J) , J=KS,NEND),ID
WRITE(43,88 5)( IINPN(J) ,RR(J) ,SS(J) , J=KS,NEND),ID
8805 FORMAT( 1X, 5(I1,F6.1,F5.1,1X), 7H P,I6)

```

```

      GO TO 81
806 CONTINUE
      NE = KS + 4
      WRITE (6,88 5) ( IINPN(J) ,RR(J) ,SS(J) , J=KS,NE ),ID
      WRITE (7,88 5) ( IINPN(J) ,RR(J) ,SS(J) , J=KS,NE ),ID
C
      IF( ITEST .GT. 0 ) GO TO 590
C
810 CONTINUE
836 CONTINUE
838 CONTINUE
      IF (KMISS .EQ. 0) GO TO 699
      WRITE (6,8900) (REFNIS(J),J= 1,KMISS)
8900 FORMAT (/31H ***** /
1          31H ***** /
2920THE VALUE OF THE REF. FOUND AT THE PREVIOUS SWEEP WAS USED AT
3THE FOLLOWING ASPECT ANGLES //, (F10.1) )
      WRITE (6,8910)
8910 FORMAT (/31H ***** /
1          31H ***** //)
C
899 CONTINUE
      JMISS =
      KMISS =
700 CONTINUE
      CALL EXIT
      GO TO 5
      END
      FUNCTION FUNC(A,B)
      AA = A/10
      FUNC = 10.*ALOG10(AA*AA - B*B)
      RETURN
      END
      SUBROUTINE SPECT3
      COMMON/BLOCK1/CKSAT(361), CKITH(4,361),LAST,IV,RRF,THOLD,IRO,DRANG
1, IRS , IA ,IRSTRT , ICTRL , VSTD , ITH, CONST , SAT , IMODE ,
2 SIGCAL , CKONE(361) , ANOISE
C
      COMMON/BLOCK2/ NS(361) , ISB(361,10) , ISNCT(361,10) ,
1INTST(361,1) , ISPCT(361,10) , ISE(361,10) , SIG(540)
      COMMON/BLOCK4/ INPN(361,30) , R(361,30) , S(361,3) ,
1NPN(361) , IINPN( 30) , RR( 30) , SS( 3 )
C
C
      COMMON/BLOCK5/ IREGBN(10) , IREGND(10)
C
      DIMENSION
1 ISBB(1) , ISEE(1) , ISNCTT(10), ISPCTT(10), INTSTT(10)
      DIMENSION ISMOTH(10)
      IREG =
      IKEN =
      IDROP =

```

```

ICONT =
IBTH =
NFASS = 1
ISPASS =
NSATT = NS(ITH)
NS(ITH) =
LAST1 = LAST + 12
WRITE (6,9071) (SIG(J), J= LAST, LAST1)
9001 FORMAT (20F6.2)
GO TO (807,907),ICTRL
C
900 IF (CKSAT(ITH) ) 790,910,790
790 IF (CKONF(ITH) .EQ. 1.0) GO TO 800
C
910 CONTINUE
DO 921 IJ = 1, NSATT
ISBB (IJ) = ISB (ITH, IJ)
ISEE (IJ) = ISE (ITH, IJ)
ISNCTT(IJ) = ISNCT(ITH, IJ)
ISPCTT(IJ) = ISPCT(ITH, IJ)
ISMOTH(IJ) =
920 INTSTT(IJ) = INTST(ITH, IJ)
C
DO 922 JK = 1, 10
ISE(ITH, JK) =
922 CONTINUE
WRITE (6,906) NSATT
9006 FORMAT (17H LOOP ON NSATT = , I3)
IJ =
921 IJ = IJ + 1
ISPASS =
IR = ISBB(IJ) + IRS
IREND = ISEE(IJ) + IRS
IRBBB = IR
NPINSA = IREND - (IRBBB+1)
WRITE(6,61) NPINSA
6010 FORMAT (33H NUMBER OF POINTS IN SATURATION = , I5)
IF (NPINSA .GT. 3) GO TO 9
GO TO (11,12,13), NPINSA
11 IF (ISPCTT(IJ) .GE. 3) GO TO 51
GO TO 399
51 NPN(ITH) = NPN(ITH) + 1
ISUBS1 = NPN(ITH)
INPN(ITH, ISUBS1) = 2
R (ITH, ISUBS1) = FLOAT(IRBBB+1-IRS) * DRANG
VPT = SIG(IRBBB+1)
WRITE (6,700) R(ITH, ISUBS1)
7000 FORMAT (2 H PEAK PLACED AT R = , F8.2)
IF (VPT .LE. ANOISE) VPT = ANOISE + 1.0
IF (INODE .EQ. 1) VPT = FUNC(VPT, CONST)
S (ITH, ISUBS1) = VPT + SIGCAL
GO TO 399

```

```

12 IF (ISPCTT(IJ) .GE. 2 )      GO TO 52
   GO TO 399
52 NPN(ITH) = NPN(ITH) + 1
   ISUBS1 = NPN(ITH)
   INPN(ITH,ISUBS1) = 2
   R (ITH,ISUBS1) = FLOAT(IRBBB+2-IRS)* DRANG
   WRITE (6,7000) R(ITH,ISUBS1)
   VPT = SIG(IRBBB+2)
   IF (VPT .LE. ANOISE) VPT = ANOISE + 1.0
   IF (IMODE .EQ. 1) VPT = FUNC(VPT,CONST)
   S (ITH,ISUBS1) = VPT + SIGCAL
   GO TO 399
13 IF (ISPCTT(IJ) .GE. 2 )      GO TO 53
   GO TO 399
53 NPN(ITH) = NPN(ITH) + 1
   ISUBS1 = NPN(ITH)
   INPN(ITH,ISUBS1) = 2
   TOP = SIG(IRBBB+1)
   JR1 = 1
   IF (SIG(IRBBB+2) .LT. TOP)      GO TO 54
   TOP = SIG(IRBBB+2)
   JR1 = 2
54 IF (SIG(IRBBB+3) .LT. TOP)      GO TO 55
   TOP = SIG(IRBBB+3)
   JR1 = 3
55 R (ITH,ISUBS1) = FLOAT(IRBBB+JR1-IRS) * DRANG
   WRITE (6,7000) R(ITH,ISUBS1)
   I3 = IRBBB+JR1
   VPT = SIG(I3)
   IF (VPT .LE. ANOISE) VPT = ANOISE + 1.0
   IF (IMODE .EQ. 1) VPT = FUNC(VPT,CONST)
   S (ITH,ISUBS1) = VPT + SIGCAL
   GO TO 399
C
C
9 ICNN = ISPCTT(IJ)
  INT = INTSTT(IJ)
  ICP = ISNCTT(IJ) - 1
  II1 = ICP + 1
  WRITE (6,9007) IJ,IR,IREND,INT,II1
9007 FORMAT ( 8H REGION ,I4,11H IR SET TO ,I4,11H RUN TO IR , I4,
1          8H INT = ,I4, 7H ICP = , I4 )
C
GO TO 10
C
800 CONTINUE
DO 81 JK = 1,1
ISE(ITH,JK) =
810 CONTINUE
IR = IRSTRT - 1
ICN =
ICP =

```

```

      INT = 1
      IREND = LAST
5    IR = IR + 1
      ICONT = ICONT + 1
      IF( SIG(IR) .GT. THOLD ) GO TO 6
      IF( IR .LT. IREND ) GO TO 5
      GO TO 4
6    IF( IR .LE. 1 ) GO TO 5
10   ICP = ICP + 1
15   CONTINUE
      IF( ICP .EQ. 3 .AND. INT .EQ. 1 ) GO TO 20
      GO TO 25
20   NPN(ITH) = NPN(ITH) + 1
      ISUBS1 = NPN(ITH)
      INPN(ITH,ISUBS1) = 1
      R (ITH,ISUBS1) = FLOAT(IR-IRS-3) * DRANG
      VPT = SIG(IR-3)
      IF( VPT .LE. ANOISE ) VPT = ANOISE + 1.0
      IF( ICODE .EQ. 1 ) VPT = FUNC(VPT,CONST)
      S (ITH,ISUBS1) = VPT + SIGCAL
      INT =
      GO TO (19,225), ICTRL
225  IF( CKONE(ITH) .EQ. .0 ) GO TO 25
19   CONTINUE
      IF( NPN(ITH) .EQ. 1 ) GO TO 25
      KNPN = NPN(ITH) - 1
      IF( INPN(ITH,KNPN) .EQ. 2 ) GO TO 25
      IF( R(ITH,ISUBS1) .EQ. R(ITH,KNPN) ) GO TO 221
      IRBEGN = R(ITH,KNPN)/DRANG + 0.9 + FLOAT(IRS)
      IF( SIG(IR) .GT. THOLD ) GO TO 21
      IIR = IR
      GO TO 22
221  NPN(ITH) = NPN(ITH) - 1
      GO TO 25
21   IIR = IR - 3
22   IF( NS(ITH) .EQ. 0 ) GO TO 222
      IRNULL = IRBEGN - IRS
      IF( ISB(ITH,NSUBS1) .GT. IRNULL ) GO TO 25
222  WRITE (6,60 )
6000 FORMAT (30H ** NO PEAK FOUND BETWEEN TWO NULLS )
      IF( (IIR-(IRBEGN+1)) .GE. 7 ) GO TO 23
      WRITE (6,602 )
6020 FORMAT (30H 7 POINTS WERE NOT ABOVE THOLD )
      GO TO 25
23   JJBEGN = IRBEGN + 1
      JJEND = IRBEGN + 7
      DO 24 IJK = JJBEGN, JJEND
      IF( SIG(IJK) .GT. THOLD ) GO TO 24
      WRITE (6,603 )
6030 FORMAT (40H 7 CONSC. POINTS ABOVE THOLD WERE NOT FOUND )
      GO TO 25
24   CONTINUE

```

```

C
  IREG = IREG * 1
  IREGN(IREG) = IRBEGN
  IREGND(IREG) = IIR
  WRITE (6,6060) IRBEGN, IIR
6060 FORMAT (20H LOCATE A PEAK BETWEEN , IS, 5H AND , IS )
C
  25 IR = IR + 1
  ICONT = ICONT + 1
  GO TO (27,26),ICTRL
  26 IF (IR .GT. IREND) GO TO 226
  GO TO 28
  226 IF (SIG(IREND) .LT. SAT) GO TO 228
  ISE(ITH,NSUBS1) = IR - IRS
  ICN = 3
  ICP =
  WRITE (6,9004) NS(ITH),ISNCT(ITH,NSUBS1),INTST(ITH,NSUBS1) ,
  1 ISB(ITH,NSUBS1), ISE(ITH,NSUBS1)
  GO TO 398
  228 IPT = 1
  ICN =
  GO TO 3
  227 IF (SIG(IREND) .LT. SAT) GO TO 400
  534 CONTINUE
  ISE(ITH,NSUBS1) = IR - IRS
  ICN = 3
  ICP =
  WRITE (6,9004) NS(ITH),ISNCT(ITH,NSUBS1),INTST(ITH,NSUBS1) ,
  1 ISB(ITH,NSUBS1), ISE(ITH,NSUBS1)
  IF ( IDROP .EQ. 0) GO TO 400
  IF (NPN(ITH) .EQ. 0) GO TO 400
  IF ( R(ITH,ISUBS1) .GT. (ISB(ITH,NSUBS1) * DRANG ) .AND.
  1 R(ITH,ISUBS1) .LT. (ISE(ITH,NSUBS1) * DRANG ) )
  2 NPN(ITH) = NPN(ITH) - 1
  ISUBS1 = NPN(ITH)
  IDROP =
  GO TO 4
  27 CONTINUE
  IF (IR .GT. IREND) GO TO 227
  28 CONTINUE
  IF (SIG(IR) .GE. SAT) GO TO 30
  IF (SIG(IR) - SIG(IR-1) ) 40,29,29
  29 IF (IDROP .EQ. 1) GO TO 25
  GO TO 1
  30 GO TO (35,25), ISPASS
  35 NS(ITH) = NS(ITH) +
  NSUBS1 = NS(ITH)
  ISB(ITH,NSUBS1) = IR-IRS-1
  ISNCT(ITH,NSUBS1) = ICP
  INTST(ITH,NSUBS1) = INT
  ISPASS = 2
  WRITE (6,9003) IR,ICONT

```

```

0003 FORMAT (20H SATURATE AT SAMPLE , I3 , 12H , ICOUNT = , I3 )
      GO TO 25
40 IF ( SIG(IR+2) .GE. SIG(IR-1)) GO TO 143
      IF (ISPASS .EQ. 1) GO TO 50
      IF (ICTRL .EQ. 2) GO TO 41
      IF ((IREND-IR) .GT. 5) GO TO 533
      IR = IREND
      GO TO 534
533 CONTINUE
      IF ( ((IR-IRS) - ISB(ITH,NSUBS1)) .LT. 25 ) GO TO 41
      IF ( SIG(IR+6) .GT. SAT .OR. SIG(IR+9) .GT. SAT ) GO TO 42
      IF (SIG(IR+12) .LT. SAT) GO TO 41
      IDROP = 1
      GO TO 25
42 CONTINUE
      IDROP = 0
      GO TO 25
41 CONTINUE
      ISF(ITH,NSUBS1) = IR-IRS
      ICP = 0
      JJ1 = NS(ITH)
      WRITE (6,9) JJ1,ISNCT(ITH,JJ1),INTST(ITH,JJ1),ISB(ITH,JJ1),
1          ISE(ITH,JJ1)
9004 FORMAT ( 8H NSATT = ,I4,8H ICP = ,I4,8H INT = , I4,
1          7H ISB = , I4,7H ISE = ,I4 )
      IF (IDROP .EQ. 1) GO TO 50
      IF (NPN(ITH) .EQ. 0) GO TO 50
      IF (R(ITH,ISUBS1) .GT. (ISB(ITH,NSUBS1) * DRANG) .AND.
1      R(ITH,ISUBS1) .LT. (ISE(ITH,NSUBS1) ) )
2      NPN(ITH) = NPN(ITH) - 1
      ISUBS1 = NPN(ITH)
      IDROP = 1
C
50 CONTINUE
      IPT = 0
      IF( ICP .GE. 3 ) IPT = 1
      ICN = 0
C
110 ICN = ICN + 1
      IF( ICN .EQ. 3 .AND. IPT .EQ. 1 ) GO TO 120
      GO TO 125
120 NPN(ITH) = NPN(ITH) + 1
      INPN(ITH,ISUBS1) = 2
      R (ITH,ISUBS1) = FLOAT(IR-IRS-3) * DRANG
      VPT = SIG(IR-3)
      IF (VPT .LE. ANOISE) VPT = ANOISE + 1.0
      IF (IMODE .EQ. 1) VPT = FUNC(VPT,CONST)
      S (ITH,ISUBS1) = VPT + SIGCAL
      IPT = 1
C
125 IR = IR + 1
      ICONT = ICONT + 1

```

```

      IF (ICTRL.EQ. 1)      GO TO 145
      IF (IR.GT. IREND)    GO TO 300
      GO TO 155
-----
143 IF ( SIG(IR+2) .GE. SAT ) GO TO 25
      IF (IDROP.EQ. 1) GO TO 29
      GO TO 10
-----
145 IF (IR.GT. IREND)      GO TO 400
155 CONTINUE
      IF (IA.GT. 1) GO TO 157
-----
162 IF ( SIG(IR) .GT. THOLD ) GO TO 165
      IBTH = IBTH + 1
      IF (ICN.LT. 3)      GO TO 125
      IF (NPASS.EQ. 2)    GO TO 125
C
      NPN(ITH) = NPN(ITH) + 1
      ISUBS1 = NPN(ITH)
      INPN(ITH,ISUBS1) = 1
      R (ITH,ISUBS1) = FLOAT(IR-IRS) * DRANG
      VPT = SIG(IR)
      IF (VPT.LE. ANOISE) VPT = ANOISE + 1.0
      IF (IMODE.EQ. 1) VPT = FUNC(VPT,CONST)
      S (ITH,ISUBS1) = VPT + SIGCAL
      NPASS = 2
      GO TO 125
-----
157 IF ( CKONE(ITH) .EQ. 0. )      GO TO 165
      IF (CKSAT(ITH) .EQ. [-1. ] ) GO TO 162
C
-----
165 IF ( SIG(IR) .LE. SIG(IR-1) ) GO TO 110
      IF (SIG(IR+2) .LE. SIG(IR-1)) GO TO 110
      IF(ISPASS.EQ. 1)      GO TO 170
      ISPCT(ITH,NSUBS1) = ICN
      ISPASS = 1
      WRITE (6,905) ISPCT(ITH,JI1)
-----
9005 FORMAT ('H ICN = , I5 )
170 INT = 0
C
-----
      IF( ICN .GE. 3) INT = 1
      IF( IBTH .EQ. 0 ) GO TO 140
      IBTH =
-----
      NPASS= 1
      INT = 1
-----
140 ICP = 1
      GO TO 15
C
-----
C
300 CONTINUE
      IF (CKONE(ITH) .EQ. 1.0) GO TO 400
      IF (ICN.LT. 3 .AND. IPT.EQ. 1) GO TO 180
      GO TO 392
-----
180 IF (ISPCT(IJ) .GT. 6) GO TO 190
      GO TO 393
-----
190 ISPCTT(IJ) = ISPCTT(IJ) - 1

```

```

      GO TO 11
C
398 CONTINUE
   IF (CKONT(ITH) .EQ. 1) GO TO 400
   IF (ISMOTH(IJ) .GT. 1) GO TO 399
   IRQUES = R(ITH,ISUBS1)/DRANG + 0.9 + FLOAT(IRS)
   IF ( IRQUES .GE. IRBBB .AND. IRQUES .LE. IREND ) GO TO 601
   IF ( NS(ITH) .EQ. 0 ) GO TO 600
   IISB = ISB(ITH,NSUBS1) + IRS
   IF (IISB .GT. IRBBB) GO TO 399
600 IREGEN(IJ) = IRBBB
   IREGND(IN) = IREND
   WRITE (6,6 4 ) IRBBB, IREND
6040 FORMAT (23H NO PEAK FOUND BETWEEN , I5, 5H AND , I5,11H SAT REGIO
1N )
   CALL SMOOTH( IJ, IR, IREND )
   ISMOTH(IJ) = 1
   INT = INTSTT(IJ)
   ICP = ISNCTT(IJ) - 1
   ISPCTT(IN) = ICNN
   ISPASS = 1
   NPASS = 1
   GO TO 10
C
601 INPNN = INPN(ITH,NSUBS1)
   GO TO (6 2,399), INPNN
602 CONTINUE
   IF (NS(ITH) .EQ. 0) GO TO 603
   IISB = ISB (ITH,NSUBS1) + IRS
   IF (IISB .GT. IRQUES) GO TO 399
603 CONTINUE
   IREGEN(IJ) = IREND
   WRITE (6,6 7 ) IRQUES, IREND
6070 FORMAT (26H XXXXX PEAK FOUND BETWEEN , I5, 5H AND , I5,47H NULL WA
1S LAST THING BETWEEN SAT. POINTS XXXXX )
   IREGND(IN) = IREND
   CALL SMOOTH( IJ, IR, IREND )
   ISMOTH(IJ) = 1
   ICP =
   INT =
   ISPASS = 1
   NPASS =
   GO TO
399 CONTINUE
   IF (ISPASS .EQ. 1) GO TO 1399
   IF ( ISE(ITH,NSUBS1) .LE. ISB(ITH,NSUBS1)) GO TO 1397
   ISPCT(ITH,NSUBS1) = ICN
   ISPASS = 1
   WRITE (6,9 5) ICN
   GO TO 1399
1397 ISE (ITH,NSUBS1) = IREND - IRS
   ICF =

```

```

ICN = 3
ISPCT(ITH,NSUBS1) = ICN
ISPASS = 1
WRITE (6,9004) NS(ITH), ISNCT(ITH,NSUBS1), INTST(ITH,NSUBS1) ,
1 ISB(ITH,NSUBS1), ISE(ITH,NSUBS1)
WRITE (6,9005) ICN
1399 CONTINUE
IF (IJ .LT. NSATT) GO TO 921
400 CONTINUE
IF ( ISPASS .EQ. 1 ) GO TO 401
IF ( ISE(ITH,NSUBS1) .LE. ISB(ITH,NSUBS1) ) GO TO 1400
ISPCT(ITH,NSUBS1) = ICN
WRITE (6,9005) ICN
ISPASS = 1
GO TO 401
1400 ISE (ITH,NSUBS1) = IREND - IRS
ICP = 0
ICN = 3
ISPCT(ITH,NSUBS1) = ICN
ISPASS = 1
WRITE (6,9004) NS(ITH), ISNCT(ITH,NSUBS1), INTST(ITH,NSUBS1) ,
1 ISB(ITH,NSUBS1), ISE(ITH,NSUBS1)
WRITE(6,9005) ICN
401 CONTINUE
C
IF ( IREG .EQ. 0 ) RETURN
IKFN = IKEN + 1
IF ( IKEN .GT. IREG ) RETURN
C
CALL SMOOTH( IKEN, IR, IREND )
C
ICP = 0
INT = 0
ISPASS = 1
NPASS = 1
GO TO 1
C
500 RETURN
END
SUBROUTINE SMOOTH( IKEN, IR, IREND )
C
COMMON/BLOCK2/ NS(361) , ISB(361,10) , ISNCT(361,10) ,
1 INTST(361,10) , ISPCT(361,10) , ISE(361,10) , SIG(54 )
COMMON/BLOCK5/ IREGBN(1) , IREGND(10)
DIMENSION AVG(3 )
C
IREONE = IREGBN(IKEN) - 1
IRETWO = IREGND(IKEN) - 1
ICOUNT = 0
DO 1 IRR = IREONE,IRETWO
ICOUNT = ICOUNT + 1
ONE = SIG(IRR)

```

```

IRR1 = IRR + 1
TWO = SIG(IRR1)
THREE = SIG(IRR+2)
AVG(ICOUNT) = ( ONE + TWO + THREE )/3.0
100 CONTINUE
DO 200 IRJ = 1, ICOUNT
IRSUB1 = IREONE + IRJ
SIG(IRSUB1) = AVG(IRJ)
200 CONTINUE
IR = IREGFN(IKEN)
IRENI = IREGND(IKEN)
RETURN
END
SUBROUTINE RFORG( I )
C
COMMON/BLOCK4/ INPN(361,30) ,R(361,30) ,S(361,30)
1INPN(361) ,IINPN( 30) ,RR( 30) ,SS( 30)
C
C
ISEQ =
10 ISEQ = ISEQ + 1
J =
JL =
RR (ISEQ) = R (I,J)
SS (ISEQ) = S (I,J)
IINPN(ISEQ) = INPN(I,J)
20 J = J +
IF( R(I,J) .GE. RR(ISEQ) ) GO TO 30
RR (ISEQ) = R (I,J)
SS (ISEQ) = S (I,J)
IINPN(ISEQ) = INPN(I,J)
JL = J
30 IF( .LT. NPN(I) ) GO TO 20
R(I, JL) = 1
IF( ISEQ .LT. NPN(I) ) GO TO 10
C
RETURN
END
SUBROUTINE SUBIRS ( DATA, IRSS , VSTD1 , IR1, IR2 )
C
DIMENSION DATA(540)
C
IR = IR1
IRSS = IR1
10 IR = IR +
IF ( DATA(IR) .GT. DATA(IRSS) ) IRSS = IR
IF ( IR .LT. IR2 ) GO TO 10
VSTD1 = DATA(IRSS)
RETURN
END
SYMLIEF DATAIN
BLOCK INPUT

```

```

INDAT BSS 3.9
IEOF BSS 1
USE PREVIOUS
DATAIN SAVE
LDA DCW
STA DCW
MME GETNOS
RTD
ZERO FA,DCW
ZERO STATR
MME GERCAD
LDA STATR
ANA =0.7 0 000 00
CMPA =0.4 0 000 00
TZE EOF
LDA =,DL
TPA RETURN
EOF LDA =1,DL
RETURN STA IEOF
RETURN DATAIN
FA BCI 1,0 0 8
STATR BSS 2
DCW1 IOTL INDAT,309
DCW BSS 1

```

```

END
MODEL 66 SPECT TEST 89.0 1.19
0.494 22.1 0.5 75.0
3 1 6 3 6 934 45 50 30 80
1
VERT/VERT 0
2
3.0 1-38.5 15. 1-38.5
3.0
3.0

```

SECTION IX

CLASS

```

C      RADSIN CLASSIFIER
COMMON X(8), NMODE(10), W(10,10,6), TH(10,10), GMAX, ICAT, MODE,
1NC, ID
DIMENSION IID(6), LVEC(6), ASP(200), VC(200,7), VCTR(200,6),
1NCONF(10),
2PIGH(10), NCAT(10,10), P(10,10,10), IC(10,10,10,10)
DIMENSION TGTID(12)
DIMENSION NVECTR(1,1)
10 CONTINUE
  READ (5, 100) NC, NDIM, NUNKWN
1000 FORMAT (2I5)
  WRITE (6, 101) NC, NDIM, NUNKWN
1001 FORMAT(1H ,34HNO. OF TARGETS USED IN TRAINING...,I2,33H...DIMENSIORR5 1
1N OF DECISION SPACE...,I2, 3H.../1H ,41HNO. OF UNKNOWN TARGETS TO
2BE PROCESSED...,I3, 3H...)
  IF (NC.GT. .AND.NC.LE.10.AND.NDIM.GT.0.AND.NDIM.LE.6 .AND.NUNKWN
1.GT.0) GO TO 11
  WRITE (6, 102)
1002 FORMAT(1H ,72HNC AND NDIM MUST BE .GT. ZERO AND .LE. TEN AND NUNKWR5 1
1N MUST BE .GT. ZERO.)
  CALL EXIT
11 CONTINUE
  READ (5, 103) (NMODE(I), I = 1, NC)
  WRITE (6, 103)
1003 FORMAT(1H ,25HCATEGORY NO. OF MODE5)
  WRITE (6, 104) (I, NMODE(I), I = 1, NC)
1004 FORMAT (5X, I2, 12X, I2)
  DO 12 I = 1, NC
  IF (NMODE(I).GT.0.AND.NMODE(I).LE.10) GO TO 12
  WRITE (6, 105)
1005 FORMAT(1H ,39HNMODE(I) MUST BE .GT. ZERO AND .LE. TEN)
  CALL EXIT
12 CONTINUE
  DO 30 I = 1, NC
  NMD = NMODE(I)
  READ (5, 106) TGTID
1006 FORMAT (12A4)
  WRITE (6, 107) I, TGTID
1007 FORMAT(1H , 8HCATEGORY,I4, 9H .... , 12A4/)
  DO 20 L = 1, NMD
  READ (5, 108) (W(L,I,J), J = 1, NDIM)
1008 FORMAT(6F10.2)
  READ (5, 109) TH(L,I),NVECTR(I,L)
1009 FORMAT(F10.2,I5)
  WRITE (6, 109) L
1009 FORMAT(1H ,11HMODE NUMBER,I2/)
  WRITE (6, 101) (W(L,I,J), J = 1, NDIM)
1010 FORMAT(1H ,24HWIGHT VECTOR COMPONENTS,/1H ,10F10.2)
  WRITE (6, 111) TH(L,I),NVECTR(I,L)
1011 FORMAT(1H ,12HTHRESHOLD = ,F10.2,14HNVECTR(I,L) = ,I5/)
C
20 CONTINUE

```

```

30 CONTINUE
DO 34 I=1,10
  PIGH(I) = .
DO 33 J=1,10
  NCAT(I,J) =
DO 32 K=1,10
  P(I,J,K) = 0.
DO 31 L=1,10
  IC(I,J,K,L) =
31 CONTINUE
32 CONTINUE
33 CONTINUE
34 CONTINUE

```

C

```

READ (5, 1000) (NCONF(I), I = 1, NC)
WRITE (6, 1013)
1013 FORMAT(1H ,48HCATEGORY      NO. OF NONZERO ELEMENTS OF C MATRIX/)
WRITE (6, 1014) (I, NCONF(I), I = 1, NC)
1014 FORMAT (5X,I2, 20X, I1 )
NNSUM =
DO 36 I=1,NC
36 NNSUM = NNSUM + NCONF(I)
DO 40 II = 1, NC
  NCF = NCONF(II)
  IF (NCF.EQ.0) GO TO 4
  READ (5,115)(I,J,K,L, IC(I,J,K,L),KK=1,NCF )
1015 FORMAT( 4(2X,4I2,I5) )
40 CONTINUE
WRITE (6, 1017)
1017 FORMAT(1H ,24H  I  J  K  L  C(I,J,K,L)/)
IF( NNSUM .EQ.  ) GO TO 81
DO 80 I = 1, NC
  NMD = NMODE(I)
DO 70 J = 1, NMD
DO 60 K = 1, NC
  NNMD = NMODE(K)
DO 50 L = 1, NNMD
  IF( IC(I,J,K,L) .EQ.  ) GO TO 50
  WRITE (6,216) I,J,K,L, IC(I,J,K,L)
2016 FORMAT( 4(1X,I2),4X,I5 )
50 CONTINUE
60 CONTINUE
70 CONTINUE
80 CONTINUE
81 CONTINUE
DO 15 I=1,NC
DO 14 J=1,NC
  NMD = NMODE(J)
DO 13 K=1,NMD
  SUMN = .
  SUML = .
  IF( J .EQ. I ) GO TO 104

```

```

NNMD = NMODE(I)
DO 105 LP=1,NNMD
SUMN = SUMN + IC(I,LP,J,K)
105 CONTINUE
DO 115 M=1,NC
IF (M .EQ. J) GO TO 115
LMD = NMODE(M)
DO 110 L=1,LMD
SUMD = SUMD + IC(M,L,J,K) - IC(J,K,M,L)
110 CONTINUE
115 CONTINUE
C
P(I,J,K) = SUMN/( NVECTR(J,K) + SUMD )
GO TO 130
C
104 CONTINUE
DO 125 M=1,NC
IF( M .EQ. I ) GO TO 125
LMD = NMODE(M)
DO 120 L=1,LMD
SUMN = SUMN + IC(M,L,I,K)
SUMD = SUMD + IC(M,L,I,K) - IC(I,K,M,L)
120 CONTINUE
125 CONTINUE
C
P(I,I,K) = 1. - SUMN/(NVECTR(I,K) + SUMD )
130 CONTINUE
140 CONTINUE
150 CONTINUE
C
C
C
DO 160 I=1,NC
WRITE (6,2050) I
2050 FORMAT(1H .38HCONDITIONAL PROBABILITIES FOR CATEGORY,I2)
DO 155 J=1,NC
WRITE (6,2055) J, (P(I,J,K),K=1,10)
2055 FORMAT(1H . 8HCATEGORY,I2,4X,10F8.4 )
155 CONTINUE
160 CONTINUE
IPROB =
700 IPROB = IPROB + 1
DO 91 I1=1,10
PIGH(I1) = 0.
DO 9 J1=1,10
NCAT(I1,J1) = 0
90 CONTINUE
91 CONTINUE
REAL (5,100) NSIG,NPDES,(IID(J),J=1,5)
C
ID = 0
DO 7 J2=1,5

```

```

      IF( IID(J21) .EQ. 0 ) GO TO 701
      ID = ID + 1
      LVEC(ID) = J21
701 CONTINUE
      READ (5,106) TGTID
      WRITE (6,952) IPROG, TGTID
9520 FORMAT(1H ,25HDISCRIMINANTS FOR UNKNOWN,I2,4H ...,12A4)
C
      DO 702 NTT=1,NSIG
      READ (5,9525) ASP(NTT), (VC(NTT,L),L=1,6)
9525 FORMAT( F6. , 4X, 7F5.0 )
      IF( NPDES .EQ. 2 ) GO TO 706
      DO 702 J23=1,ID
      LLV = LVEC(J23)
      VCTR(NTT,J23) = VC(NTT,LLV)
702 CONTINUE
      GO TO 815
706 CONTINUE
      DO 710 J23=1,ID
      LLVEC = LVEC(J23)
      GO TO (801,802,803,804,805),LLVEC
801 VCTR(NTT,J23) = AMAX1(VC(NTT,1),VC(NTT,4))
      GO TO 710
802 VCTR(NTT,J23) = AMAX1(VC(NTT,2),VC(NTT,5))
      GO TO 710
803 VCTR(NTT,J23) = AMAX1(VC(NTT,3),VC(NTT,6))
      GO TO 710
804 VCTR(NTT,J23) = AMIN1(VC(NTT,3),VC(NTT,6))
      GO TO 710
805 S1 = 1.**(VC(NTT,3)/20.)
      S2 = 1.**(VC(NTT,6)/20.)
      VCTR(NTT,J23) = ABS(S1-S2)/(S1+S2)
C
710 CONTINUE
815 WRITE (6,953) ASP(NTT), (VCTR(NTT,L),L=1,ID)
9530 FORMAT(1X,1 F8.2)
703 CONTINUE
C
      WRITE (6,9500)
9500 FORMAT(1H ,75HCLASSIFIED AS ** CAT1 CAT2 CAT3 CAT4 CAT5 CAT6
      CAT7 CAT8 CAT9 CAT10)
      WRITE (6,9501)
9501 FORMAT(1H ,16HCATEGORY MOLE **)
C
      DO 900 NTT=1,NSIG
C
      DO 820 J=1,ID
      X(J) = VCTR(NTT,J)
820 CONTINUE
C
      CALL DECIE
C

```

```

NCAT(ICAT, MODE) = NCAT(ICAT, MODE) + 1
DO 699 I = 1, NC
  NMD = NMODE(I)
  SUM = .
  DO 62 J = 1, NC
    NNMD = NMODE(J)
    DO 61 L = 1, NNMD
      SUM = SUM + FLOAT(NCAT(J,L))*P(I,J,L)
610 CONTINUE
620 CONTINUE
  PIGH(I) = SUM/FLOAT(NTT)
699 CONTINUE
  WRITE (6,9510) ICAT,MODE,(PIGH(I),I=1,NC)
9510 FORMAT(4X,I2,5X,I2,4H **,F5.3,9(1X,F5.3))
C
900 CONTINUE
  IF( IPROB .LT. NUNKWN ) GO TO 700
  GO TO 1
C
  END
  SUBROUTINE DECIDE
  COMMON X(6), NMODE(1), W(10,10,6), TH(10,10), GMAX, ICAT, MODE,
  NC, ID
  DIMENSION G(1, 10)
  DO 2 I = 1, NC
    NMD = NMODE(I)
    DO 1 L = 1, NMD
      G(L,I) = .
10 CONTINUE
20 CONTINUE
    DO 7 I = 1, NC
      NMD = NMODE(I)
      DO 6 L = 1, NMD
        DO 5 J = 1, ID
          G(L,I) = G(L,I) + X(J)*W(L,I,J)
50 CONTINUE
          G(L,I) = G(L,I) + TH(L,I)
          IF (L.EQ.1) GO TO 55
          IF (G(L,I).LT.GMMAX) GO TO 60
55 LODE = L
          GMMAX = G(L,I)
60 CONTINUE
          IF (L.EQ.1) GO TO 65
          IF (GMMAX.LT.GMAX) GO TO 70
65 ICAT = I
          MODE = LODE
          GMAX = GMMAX
70 CONTINUE
          RETURN
  END
3 2 1
1 2

```

TRAINING TARGET NO. 1... MODEL A1/59

4.608 45.88  
-1063.115 51

TRAINING TARGET NO. 2... MODEL 8/19

2.078 16.759  
-142.588 51

TRAINING TARGET NO. 3... MODEL 66

2.111 9.8 5  
450.301 36

7.133 6.630  
-0.842 15

0 3  
2 1 3 1 3  
101 2 1

	MODEL	65		9.0	2	19
0.0	2.	2.8-18.7	2.	19.8-19.1	0.5	
0.5	2.	2.8-18.3	2.	19.8-17.7	1.0	
1.0	2.	2.3-18.9	3.	18.8-17.6	2.0	
1.5	2.	2.3-18.3	2.	20.3-18.0	1.0	
2.0	2.	2.3-18.9	3.	19.3-20.8	1.5	
2.5	3.	19.8-21.3	3.	20.3-23.0	0.0	
3.0	3.	2.3-2.9	2.	9.3-25.7	19.8	
3.5	3.	19.3-22.5	3.0	9.3-26.6	19.8	
4.0	3.	19.8-24.2	3.0	24.2-26.5	1.0	
4.5	3.	19.8-26.7	2.	19.3-22.8	0.5	
5.0	3.	19.8-27.7	2.	20.3-21.6	19.8	
5.5	3.	21.7-27.0	2.	9.8-20.2	19.8	
6.0	3.	21.3-27.3	3.	9.8-20.8	19.8	
6.5	3.	21.3-27.3	3.	9.8-20.3	19.3	
7.0	2.	2.3-27.1	3.	19.3-22.2	19.3	
7.5	2.	2.8-27.9	3.0	9.3-24.3	19.3	
8.0	2.	19.3-27.6	3.	18.8-25.3	18.3	
8.5	2.	19.8-27.7	3.	18.8-25.7	18.8	
9.0	3.	23.7-26.9	3.	9.3-24.0	19.3	
9.5	4.	23.7-27.5	2.	9.3-22.9	20.8	
10.0	4.	24.7-28.1	2.	9.3-22.0	20.3	
10.5	3.	24.2-27.5	2.	9.3-21.5	18.8	
11.0	3.	22.2-28.2	2.	18.3-23.1	18.3	
11.5	3.	23.7-27.3	2.	9.3-23.8	20.3	
12.0	3.	24.7-27.5	2.	9.3-25.5	20.3	
12.5	2.	22.7-27.2	2.	18.3-26.6	0.5	
13.0	2.	22.7-28.2	2.	18.3-26.6	0.5	
13.5	2.	23.7-28.0	4.	23.7-26.2	0.5	
14.0	3.	22.7-27.0	3.	18.8-26.5	18.8	
14.5	3.	23.7-27.4	3.	18.8-26.5	19.8	
15.0	3.	22.7-27.7	3.	18.8-26.0	0.5	
15.5	3.	22.2-27.6	2.	18.3-26.0	0.5	
16.0	2.	21.2-27.5	2.	18.3-27.2	0.5	
16.5	2.	22.7-27.8	3.	9.3-26.1	0.0	
17.0	2.	23.7-27.7	3.	18.3-27.9	1.0	
17.5	2.	22.7-27.2	3.	18.3-26.9	0.5	
18.0	2.	22.7-27.2	4.	18.8-27.0	1.0	

3130	18.5	2.	22.7-27.2	3.	8.3-26.8	0.5
3140	19.0	3.	23.2-27.3	3.	8.3-27.6	0.5
3150	19.5	2.	22.7-28.1	3.	8.8-26.5	1.0
3160	20.0	2.	22.2-27.1	2.	7.3-27.1	0.5
3170	20.5	2.	22.2-27.1	3.	23.2-26.9	1.0
3180	21.0	2.	23.2-27.4	2.	8.8-26.9	0.0
3190	21.5	2.	22.2-27.9	2.	7.8-26.8	0.0
3200	22.0	2.	22.7-28.0	2.	9.3-25.8	1.0
3210	22.5	3.	21.7-26.5	2.	8.3-26.2	1.5
3220	23.0	2.	21.8-27.1	2.	8.8-26.4	1.0
3230	23.5	2.	21.3-27.4	2.	6.8-26.5	0.5
3240	24.0	2.	22.2-27.2	3.	6.8-26.1	0.0
3250	24.5	2.	21.7-26.5	3.	7.3-25.8	0.0
3260	25.0	2.	21.7-26.6	2.	5.3-26.0	0.5
3270	25.5	5.	21.8-26.8	2.	6.8-26.4	1.0
3280	26.0	3.	21.7-26.7	2.	6.3-25.4	1.5
3290	26.5	3.	21.2-26.6	2.	6.3-25.4	0.5
3300	27.0	3.	21.7-26.0	2.	6.3-25.5	0.0
3310	27.5	2.	21.7-26.9	2.	6.3-26.1	1.0
3320	28.0	3.	21.8-27.2	2.	6.3-25.6	0.0
3330	28.5	3.	21.3-27.2	2.	5.8-26.0	0.0
3340	29.0	3.	21.8-26.1	2.	5.3-26.0	1.0
3350	29.5	3.	21.2-26.7	2.	5.3-25.9	0.0
3360	30.0	3.	21.3-26.3	2.	5.3-26.1	0.0
3370	30.5	3.	19.8-26.2	2.	4.3-26.3	1.0
3380	31.0	3.	21.3-27.0	2.	4.8-26.1	0.5
3390	31.5	3.	21.8-26.0	2.	4.8-25.9	1.0
3400	32.0	3.	21.3-26.7	2.	4.8-26.6	0.0
3410	32.5	3.	21.3-27.1	2.	3.8-25.5	0.5
3420	33.0	3.	21.3-26.3	2.	4.8-25.0	1.0
3430	33.5	3.	21.3-27.0	2.	5.3-25.7	1.5
3440	34.0	3.	19.8-26.3	2.	4.8-25.3	0.0
3450	34.5	3.	19.3-25.8	2.	4.3-24.9	0.5
3460	35.0	3.	19.3-25.7	2.	4.3-24.7	0.5
3470	35.5	3.	21.3-25.5	2.	3.8-24.5	0.5
3480	36.0	2.	13.8-25.4	2.	4.8-24.3	0.5
3490	36.5	2.	12.4-25.2	2.	4.8-23.9	1.0
3500	37.0	2.	13.3-25.0	2.	3.9-24.1	1.0
3510	37.5	2.	13.3-25.4	2.	3.8-24.3	0.5
3520	38.0	1.	11.9-24.8	2.	4.3-23.6	1.5
3530	38.5	1.	11.9-24.8	2.	4.3-24.2	1.0
3540	39.0	2.	13.3-25.8	2.	3.8-24.1	0.5
3550	39.5	2.	13.3-24.3	2.	3.4-23.9	0.5
3560	40.0	2.	11.9-24.0	2.	3.8-23.4	1.5
3570	40.5	1.	11.9-24.5	2.	3.8-23.7	1.0
3580	41.0	1.	11.9-24.6	2.	3.4-23.6	1.0
3590	41.5	2.	12.9-24.6	2.	3.4-24.0	0.5
3600	42.0	2.	13.3-24.4	2.	2.9-23.7	0.5
3610	42.5	2.	11.8-24.4	2.	3.4-23.7	2.0
3620	43.0	2.	13.4-24.5	2.	2.9-24.0	0.5
3630	43.5	2.	11.9-24.1	2.	2.9-23.5	1.0
3640	44.0	2.	12.3-23.7	2.	2.8-22.8	0.5

3650	44.5	2.	12.4-24.1	2.	12.4-22.5	0.5
3660	45.0	2.	11.4-24.2	2.	11.9-23.2	0.5
3670	45.5	2.	11.9-23.5	2.	11.9-21.8	0.5
3680	46.0	2.	9.9-22.9	2.	11.9-21.3	0.5
3690	46.5	2.	11.4-23.3	2.	11.4-22.0	1.5
3700	47.0	2.	11.4-23.7	2.	11.4-21.1	0.5
3710	47.5	2.	11.4-23.0	2.	11.9-22.2	1.0
3720	48.0	2.	11.4-22.3	2.	11.4-21.9	0.0
3730	48.5	2.	12.4-22.6	2.	11.4-21.6	0.5
3740	49.0	2.	11.9-22.6	2.	10.9-21.1	1.0
3750	49.5	2.	11.4-22.9	2.	11.4-21.2	1.5
3760	50.0	2.	9.9-22.0	2.	10.4-21.7	1.0

SECTION X

TRAIN

```

C      RADSIH TRAINER                2
COMMON KB,
1 C, TV(10,181,10), TTV(10,181,10), BW(10,10,10), BTM(10,10),
2 W(10, 10,10), TH(10,10), AVDIST(10), X(12),
3 IID(10), ASP(10,181), LVEC(10), NWS(10), KWS(10,10), MODCNT, IQWS
COMMON
1 NC, ID, I, NPASS, NM, IMPRV, IBEST, ITRAN, MODE, ICAT,
2 NLV(10), NMODE(10), MBOD(10), NCORR
COMMON/BLOCK1/ NWSB(10), KWSB(10,10)
COMMON/BLOC2/ INE(10), NE(10,10), INEMOD(10,10)
COMMON/BLOC3/ MODVC(10,181), MODVCB(10,181), KCNTT(10,10),
1 AVMODE(10,10)
COMMON/BLOC4/ CC(10,10), IFORCE
DIMENSION V3IDL(5), V3IDH(5), TGTID(12)

```

C  
C  
C

```

10 CONTINUE
WRITE (6,750)
WRITE (6, 1000)
1000 FORMAT (1H, 22H OUTPUT FROM MAIN... /)
WRITE (6,752)

```

C  
C  
C  
C  
C

```

C = 4.0
1003 FORMAT( 6F10.0 )
READ (5,1003) NC,NPROBS
1004 FORMAT(12I5)
WRITE (6,1004) NC,NPROBS
1004 FORMAT (1H, 5HNC = ,I2, 11H NPROBS = ,I2)
IF(NC.GT.0.AND.NC.LE.10.AND.NPROBS.GT;0.AND.NPROBS.LE;10)GO TO 11
WRITE (6, 1005)
1005 FORMAT(3H, 19HCHECK NC AND NPROBS)
CALL EXIT
11 CONTINUE

```

C  
C  
C  
C  
C

```

WRITE (6,750)
NTT = 0
CK = 4.0
DO 40 I = 1, NC
READ (5, 1001) THET1, THET2, DELTH
WRITE (6, 3003) THET1, THET2, DELTH
3003 FORMAT (1H, 84THET1 = ,F10.4,10H THET2 = ,F10.4,10H DELTH = ,
1F10.4)
NCMISS = 0

```

```

ITGT = 1
THET11 = THET1
THET21 = THET2
DELTH1 = DELTH
3000 READ (5, 3004) TGTID, NPOL
    FORMAT (12A4, 7X, I8)
    WRITE (6, 3005) ITGT, TGTID, NPOL
3005 FORMAT (/14, 13HCATEGORY NO. , 13H3H.?, 12A4, 29H NO: POLARIZATIONS
1 AVAILABLE /13)
    READ (5, 3006) DTMET
3006 FORMAT (26X, F19.0)
    WRITE (6, 3007) DTMET
3007 FORMAT (1H, 17HASPECT INCREMENT , F10.9, 9H DEGREE$)
    IF (DELTH1.GE.DTMET) GO TO 500
    DELTH1 = DTMET
500 CONTINUE
902 CONTINUE
    DO 504 L = 1, NPOL
    READ (5, 3010) NVOID
3100 FORMAT (32X, I4)
    IF (NVOID.EQ.0) GO TO 504
    READ (5, 3011) (VOIDL(K), VOIDH(K) , K = 1, NVOID)
3101 FORMAT (10F6.0 )
    504 CONTINUE
    IF (NVOID.EQ.0) GO TO 600
    WRITE (6, 3050)
3050 FORMAT (1H, 142HNO? VOIDS AND THEIR LOWER AND UPPER LIMITS?
    WRITE (6, 3011) NVOID, (VOIDL(J), VOIDH(J) , J = 1, NVOID)
3011 FORMAT (1X, I4, 3X, 10F6.1 )
    DO 506 L = 1, NVOID
    IF (THET1.GE.VOIDL(L).AND.THET1.LT.VOIDH(L)) THET11=VOIDH(L)
    IF (THET2.GT.VOIDL(L).AND.THET2.LE.VOIDH(L)) THET21=VOIDL(L)
    IF (THET11.LT.THET21) GO TO 506
3052 FORMAT (1H, 66HASPECT SECTOR CHOSEN FALLS WITHIN A VOID IN THE DAT
1A FOR CATEGORY , 13)
    CALL EXIT
500 CONTINUE
    DO 508 L = 1, NVOID
    VOYD = 0.5*(VOIDL(L) + VOIDH(L))
    IF (VOYD.GT.THET11.AND.VOYD.LT.THET21) NCMISS = FLOAT(NCMISS) +
1VOYD/DTMET - 1.0
508 CONTINUE
600 NCDS = (THET21 - THET11)/DTMET + 1.0 = FLOAT(NCMISS)
    ISKP = DELTH/DTMET * 0.4
    ICDS = 0
    NLV(ITGT) = 1
    WRITE (6, 6010) I
6000 FORMAT (/3X, 3HTRAINING VECTORS FOR CATEGORY , I2)
C
    TTV(ITGT, 1, 5) = 1.0
    TTV(ITGT, 1, 6) = 0.5
589 CONTINUE

```

```

      JJ = NLV(ITGT)
520 READ (5,5003) ASP(ITGT,JJ),(TTV(ITGT,JJ,J),J=1,6)
      WRITE (6,6001) ASP(ITGT,JJ),NTTV(ITGT,JJ,J),J=1,6)
5003 FORMAT( F6.2,4X,7F5.0 )
6001 FORMAT(1X,10F8.2 )
C
524 ICDS = ICDS + 1
C
525 NLV(ITGT) = NLV(ITGT) + 1
      IF (NCDS.LE.ICDS) GO TO 530
      IF (ISKP.EQ.0) GO TO 509
      IBDM = NCDS - (ICDS + ISKP)
      IF (IBDM.LT.0) GO TO 527
      DO 526 LL = 1,ISKP
4000 READ (5, 4000)
      FORMAT (72X)
526 CONTINUE
      ICDS = ICDS + ISKP
      IF (NCDS.LE.ICDS) GO TO 530
      GO TO 509
527 LLL = NCDS - ICDS
      DO 528 LL = 1,LLL
      READ (5, 4000)
528 CONTINUE
530 NLV(ITGT) = NLV(ITGT) - 1
      NTT = NTT + NLV(ITGT)
40 CONTINUE
      NSIG = NTT
      IPROB = 0
700 IPROB = IPROB + 1
      NPASS = 1
      IBEST = 0
C
C
      READ (5,1003) NPDES, (IID(J21),J21=1,5)
      ID = 0
      DO 701 J21=1,5
      IF( IID(J21) .EQ. 0 ) GO TO 701
      ID = ID + 1
      LVEC(ID) = J21
701 CONTINUE
C
      WRITE (6,7000) IPROB
7000 FORMAT (////1 X,33HDISCRIMINANTS FOR PROBLEM NUMBER ,I2)
C
      DO 704 J21=1,NC
      WRITE (6,7001) J21
7001 FORMAT (/14 ,9HCATEGORY ,I2)
      J20 = NLV(J21)
      DO 703 J22=1,J20
      MODVC(J21,J22) = 1
      IF( NPDES .EQ. 2 ) GO TO 706

```

```

DO 702 J23=1, ID
JJVEC = LVEC(J23)
TV(J21, J22, J23) = TTV(J21, J22, JJVEC)
702 CONTINUE
GO TO 815
706 CONTINUE
DO 710 J23=1, ID
LLVEC = LVEC(J23)
GO TO (801, 802, 803, 804, 805), LLVEC
801 TV(J21, J22, J23) = AMAX1(TTV(J21, J22, 1), TTV(J21, J22, 4))
GO TO 710
802 TV(J21, J22, J23) = AMAX1(TTV(J21, J22, 2), TTV(J21, J22, 5))
GO TO 710
803 TV(J21, J22, J23) = AMAX1(TTV(J21, J22, 3), TTV(J21, J22, 6))
GO TO 710
804 TV(J21, J22, J23) = AMIN1(TTV(J21, J22, 3), TTV(J21, J22, 6))
GO TO 710
805 S1 = 10. * (TTV(J21, J22, 3) / 20.)
S2 = 10. * (TTV(J21, J22, 6) / 20.)
TV(J21, J22, J23) = ABS(S1 - S2) / (S1 + S2)
710 CONTINUE
815 WRITE (6, 6001) ASP(J21, J22), (TV(J21, J22, J), J=1, ID)
703 CONTINUE
704 CONTINUE

```

C  
C  
C  
C

```

DO 41 I = 1, NC
NWS(I) = 0
NWSB(I) = 0
41 CONTINUE
15 IMD = 0
DO 740 I=1, NC
MODPAS = 0
IF( NPASS .GT. 1 ) GO TO 730
NMODE(I) = 1
CALL UNIMOD
IF( NPASS .EQ. 1 ) GO TO 740
730 CONTINUE
IF( INE(I) .EQ. 0 ) GO TO 740
MODCNT = 0
735 CALL NUMOD
IF( NM .EQ. 0 ) GO TO 740
IMD = 1
MODCNT = MODCNT + 1
CALL TRAN
IF( MODCNT .GE. 3 ) GO TO 740
IF( IFORCE .EQ. 1 ) GO TO 740
MODPAS = MODPAS + 1
IF( MODPAS .GE. 20 ) GO TO 740
GO TO 735

```

```

C 780 CONTINUE
  IF (NPASS.EQ.1) GO TO 45
  IF (IMD.EQ.0) GO TO 50
45 CONTINUE
  WRITE (6,7500)
7500 FORMAT (7/1H ,82H.....)
1.....)
  WRITE (6,7510)
7510 FORMAT (30X,3 H OUTPUT FROM SUBROUTINE DISTNC)
  WRITE (6,7520)
7520 FORMAT (1H ,82H.....)
1.....)
  DO 46 I =1,NC
  IF( NPASS .EQ. 1 ) GO TO 200
  IF( INE(I) .NE. 0) GO TO 200
  WRITE (6,8030) I
8030 FORMAT (/14 ,25HINFORMATION FOR CATEGORY ,13,15H IS SAME AS FOR,
1/1H , 13HPREVIOUS PASS)
  GO TO 46
200 CONTINUE
  CALL DISTNC
  NMD = NMODE(I)
  IF( NPASS .EQ. 1 ) GO TO 46
  WRITE (6,7530)
7530 FORMAT (/14 , 32HNO. OF TRAINING VECTORS PER MODE)
  WRITE (6,7535) ( L, KCNTT(I,L),L=1,NMD )
7535 FORMAT(1X,13,10X7I6 )
  46 CONTINUE
  WRITE (6,7540)
  WRITE (6,7540)
7540 FORMAT (30X, 27HSTABILIZED OUTPUT FROM TRAN)
  WRITE (6,7520)
  DO 48 I =1,NC
  WRITE (6,7545) I
7545 FORMAT (/14 , 13HCATEGORY NO. ,13/)
  IF( NPASS .EQ. 1 ) GO TO 210
  IF( INE(I) .NE. 0) GO TO 210
  WRITE (6,8040)
8040 FORMAT (/14 ,44HINFORMATION FOR THIS CATEGORY IS SAME AS FOR.
1/1H , 13HPREVIOUS PASS)
  GO TO 48
210 CONTINUE
  NMD = NMODE(I)
  DO 47 L=1,NMD
  WRITE (6,7550) L
7550 FORMAT (1H , 9HMODE NO. , 13)
  WRITE (6,7555) ( W(L,I,J), J=1,1D )
7555 FORMAT(10X,10(4X,F8,3) )
  WRITE (6,1017) TW(L,I)
  47 CONTINUE
  48 CONTINUE

```

```

WRITE (6,7500)
WRITE (6,7565)
7565 FORMAT (3X, 28H OUTPUT FROM SUBROUTINE EVAL)
WRITE (6,7520)
DO 52 I=1,NC
  INE(I) = 0
  NMD = NMODE(I)
  DO 53 K1=1,NMD
53  INEMOD(I,K1) = 0
  DO 51 J=1,NC
  NE(I,J) = 0
51  CONTINUE
52  CONTINUE
  CALL EVAL
  IF (NCORR.EQ.NSIG) GO TO 65
  IF (IMPRUV.EQ.1) GO TO 59
50  NPASS = NPASS + 1
  GO TO 60
55  NPASS = 2
60  IF ( NPASS .GT. 4 ) GO TO 70
  WRONG = NSIG - NCORR
  DO 61 I=1,NC
  NMD = NMODE(I)
  DO 62 J=1,NMD
  EMOD = INEMOD(I,J)
  CC(I,J) = CK*(1. - EMOD/WRONG )
  IF( CC(I,J) .LT. 3. ) CC(I,J) = 3.
62  CONTINUE
61  CONTINUE
  GO TO 15
65  WRITE (6, 1018)
1018 FORMAT (1H0, 43H **** ALL VECTORS CLASSIFIED CORRECTLY ****)
  WRITE (6,7500)
70  WRITE (6, 1005)
  WRITE (6,7520)
  WRITE (6,7520)
  WRITE (6,7520)
  WRITE (6, 1013) 1BEST
1013 FORMAT (1H0, 38H BEST PERFORMANCE ON TRAINING SET...? ,I10/)
  DO 90 I = 1, NC
  NPN = NWSB(I)
  NEVCR = NLV(I)
  NMD = MBOD(I)
  WRITE (6, 1014) I
1014 FORMAT (/35X, 43H FINAL WEIGHTS AND THRESHOLDS FOR CATEGORY ,I3)
  WRITE (6, 2000) NWSB(I)
2000 FORMAT (35X, 32H (TOTAL NUMBER OF WILD SHOTS IS ,I3,2H.) )
  WRITE (6,8000)
8000 FORMAT (35X, 37H*****#*****#*****#*****#)
  DO 80 L = 1, NMD
  WRITE (6, 1015) L
1015 FORMAT (1H0, 13H MODE NUMBER , I4)

```

```

1026 WRITE (6, 1016) (BW(L,I,J), J = 1, ID)
      FORMAT (24X, 10(2X,F8.3))
      WRITE (6, 1017) BTH(L,I)
1027 FORMAT (26X, 13H THRESHOLD = , F10.3)
      WRITE (6, 8010)
0820 FORMAT (/ 16X, 27H ASPECT DISCRIMINANTS:...,)
      DO 79 K=1, NVECR
      IF (MODVCB(I,K) .NE. L) GO TO 79
      IF (NWSB(I).EQ.0) GO TO 76
      DO 74 ICK = 1, NPN
      IF (K.NE.K4S3(I,ICK)) GO TO 74
      WRITE (6, 2001) ASP(I,K), (TV(I,K,JJ), JJ = 1, ID)
2601 FORMAT (1H, 16H***WILD SHOT***, F5.1, 2X, 10(2X,F8.3))
      GO TO 79
      74 CONTINUE
      75 CONTINUE
      WRITE (6, 8020) ASP(I,K), (TV(I,K,JJ), JJ=1, ID)
0820 FORMAT( 17X, F5.1, 2X, 10(2X, F8.3) )
      79 CONTINUE
      80 CONTINUE
      90 CONTINUE

```

C  
C

```

      IF ( IPROB .LT. NPROBS ) GO TO 700
      GO TO 10
      END
      SUBROUTINE UNIMOD

```

C

```

      COMMON KB,
      1 C, TV(10,181,10), TTV(10,181,10), BW(10,10,10), BTH(10,10),
      2 W(10,10,10), TH(10,10), AVDIST(10), X(12),
      3 IID(10), ASP(10,181), LVEC(10), NWS(10), KWS(10,10), MODCNT, IGWS RR5U0
      COMMON
      1 NC, ID, I, NPASS, NM, IMPROV, IBEST, ITRAN, MODE, ICAT,
      2 NLV(10), VMODE(10), MBOD(10), N CORR

```

C  
C

```

      DO 1 J = 1, ID
      W(1,I,J) = 0.0
10 CONTINUE
      TH(1,I) = 0.0
      NVECR = NLV(I)
      DO 3 K = 1, NVECR
      DO 20 J = 1, ID
      W(1,I,J) = W(1,I,J) + TV(I,K,J)
20 CONTINUE
30 CONTINUE
      DO 40 J = 1, ID
      W(1,I,J) = W(1,I,J)/FLOAT(NVECR)
      TH(1,I) = TH(1,I) + W(1,I,J)*W(1,I,J)
40 CONTINUE
      TH(1,I) = -TH(1,I)/2.

```

C  
C

RETURN  
END  
SUBROUTINE NJMOD

C

COMMON KB,  
1 C, TV(10,181,10), TTV(10,181,10), BW(10,10,10), BTH(10,10),  
2 W(10,10,10), TH(10,10), AVDIST(10), X(12),  
3 ID(10), ASP(10,181), LVBC(10), NWS(10), KWS(10,10), MODCNT, IGWS RR5NO  
COMMON  
1 NC, ID, I, NPASS, NM, IMPRUV, IBEST, ITRAN, MODE, ICATZ  
2 NLV(10), NMODE(10), MBOD(10), N CORR  
COMMON/BLOCK2/ INE(10), NE(10,10), INEMOD(10,10)  
COMMON/BLOCK3/ MODVC(10,181), MODVCB(10,181), KCNTT(10,10),  
1 AVMODE(10,10)  
COMMON/BLOCK4/ CC(10,10), IFORCE  
DIMENSION AVE(10)

C  
C

NFORCE = 0  
IFORCE = 0  
NMD = NMODE(I)  
DO 4 L=1,NMD  
AVE(L) = CC(I,L)\*AVMODE(I,L)  
IF (AVE(L) .LT. .001) AVE(L) = .001  
4 CONTINUE  
1 CONTINUE  
ITRAN = 1  
NM = 0  
IF (NMODE(I).GE.10) GO TO 50  
NVECR = NLV(I)  
DO 30 K = 1, NVECR  
IF (NWS(I).EQ.0) GO TO 6  
NNN = NWS(I)  
IF (NNN.GT.1) NNN = 10  
DO 5 N1 = 1, NNN  
IF (K.EQ.KWS(I,N1)) GO TO 30  
5 CONTINUE  
6 CONTINUE  
DO 10 J = 1, ID  
Y(J) = TV(I,K,J)  
10 CONTINUE  
CALL DECIDE  
IF (INEMOD(I,MODE) .EQ. 0) GO TO 30  
DIS = 0.0  
DO 20 J = 1, ID  
DIS = DIS + (W(MODE,I,J)-TV(I,K,J))\*(W(MODE,I,J)-TV(I,K,J))  
20 CONTINUE  
DIS = SORT(DIS)  
IF (DIS .LE. AVE(MODE)) GO TO 30  
KB = K

```

60 GO TO 55
CONTINUE
GO TO 50
65 NM = 1
NMODE(I) = NMODE(I) + 1
NMD = NMODE(I)
CC(I,NMD) = CC(I,MODE)
AVMODE(I,NMD) = AVE(MODE)
INEMOD(I,NMD) = INEMOD(I,MODE)
TH(NMD,I) = 0.0
DO 40 J = 1, ID
W(NMD,I,J) = TV(1,KB;J)
TH(NMD,I) = TH(NMD,I) + W(NMD,I,J)*W(NMD,I,J)
40 CONTINUE
TH(NMD,I) = -TH(NMD,I)/27
70 CONTINUE
IF( NM .EQ. 1 ) GO TO 70
IF( MODCNT .GT. 0 ) GO TO 70
NFORCE = NFORCE + 1
IF( NFORCE .GE. 10 ) GO TO 70
IFORCE = 1
DO 60 L=1,NMD
60 AVE(L) = 0.9*AVE(L)
GO TO 1
70 CONTINUE
RETURN
END

```

SUBROUTINE DISTNC

```

C
COMMON KB;
1 C, TV(10,181,10), TTV(10,181,10), BW(10,10,10), BTH(10,10),
2 W(10,10,10), TH(10,10), AVDIST(10), X(12),
3 ID(10), ASP(10,181), LVEC(10), NWS(10), KWS(10,10), MODCNT, IGWS RR500
COMMON
1 NC, ID, 1, NPASS, NM, IMPROV, IBEST, ITRAN, MODE, ICAT;
2 NLV(10), NMODE(10), MBOD(10), NCCORR
COMMON/BLOCK3/ MODVC(10,181), MODVCB(10,181), KCNTT(10,10),
1 AVMODE(10,10)
DIMENSION ICNT(10)

```

```

C
C
ITRAN = 1
AVDIST(I) = 0.0
NMD = NMODE(I)
DO 10 L = 1, NMD
AVMODE(I,L) = 0.
ICNT(L) = 0
KCNTT(I,L) = 0
10 CONTINUE
IF( NPASS .GT. 1 ) WRITE(6,1004)
1004 FORMAT (/14, 3BH CAT. NO: TRAIN. VEC. NO. MODE NO.)
NVEC = NLV(I)

```

```

DO 40 K = 1, NVECR
DO 20 J = 1, ID
X(J) = TV(I,K,J)
20 CONTINUE
CALL DECIDE
IF( NPASS .GT. 1 ) WRITE(6,1003) I,K,MODE
1003 FORMAT (1H ,3X,13,12X,13,12X,13)
ICNT(MODE) = ICNT(MODE) + 1
MODVC(I,K) = MODE
DIS = 0.0
DO 30 J = 1, ID
DIS = DIS + (W(MODE,I,J)-TV(I,K,J))*(W(MODE,I,J)+TV(I,K,J))
30 CONTINUE
AVMODE(I,MODE) = AVMODE(I,MODE) + SQRT(DIS)
40 CONTINUE
DO 50 L = 1, NMD
AVMODE(I,L) = AVMODE(I,L)/FLOAT(ICNT(L))
KCNT(I,L) = ICNT(L)
WRITE (6,1001) L,AVMODE(I,L)
1001 FORMAT (1H , 8HMODE NO.,13, 32H MEAN DISTANCE TO MODE VECTOR = ,
1F10.3)
AVDIST(I) = AVDIST(I) + AVMODE(I,L)
50 CONTINUE
AVDIST(I) = AVDIST(I)/FLOAT(NMD)
WRITE (6, 1002) I, NMD, AVDIST(I)
1002 FORMAT (1H , 9HCATEGORY,12, 15H) NO, MODES =,13, 27H OVERALL RP500
1MEAN DISTANCE = ;F8.3/
RETURN
END
SUBROUTINE DECIDE
C
COMMON KB,
1 C, TV(10,101,10) , TTV(10,101,10) , BW(10,10,10) , BTW(10,10) ,
2 W(10, 10,10) , TH(1,10) , AVDIST(10) , X(12) ,
3 IID(10) , ASP(10,101) , LVEC(10) , NWS(10) , KWS(10,10) , MODCNT , IGWS RR500
COMMON
1 NC, ID, I, NPASS, NM, IMPROV, IGEST, ITRAN, MODE, ICAT,
2 NLV(10) , NMODE(10) , MBOD(10) , NOORR
DIMENSION
10(10,10)
C
C
IF (ITRAN.EQ.1) GO TO 10
II = 1
IUP = 1
GO TO 20
20 II = 1
IUP = NC
20 DO 40 II = II, IUP
NMD = NMODE(II)
DO 30 L = 1, NMD
S(L,II) = 0.0

```

```

60 CONTINUE
60 CONTINUE
DO 90 I1 = I1, IUP
  NMD = NMODE(I1)
  DO 70 L = 1, NMD
    DO 50 J = 1, ID
      G(L,I1) = Z(L,I1) + X(J)*W(L,I1,J)
50 CONTINUE
      G(L,I1) = Z(L,I1) + YH(L,I1)
      IF (L.EQ.1) GO TO 60
      IF (G(L,I1).LT.GMMAX) GO TO 70
60 LODE = L
      GMMAX = G(L,I1)
70 CONTINUE
      IF (I1.EQ.1.OR.ITRAN.EQ.1) GO TO 80
      IF (GMMAX.LT.GMAX) GO TO 90
80 ICAT = I1
      MODE = LODE
      GMAX = GMMAX
90 CONTINUE
      RETURN
      END
      SUBROUTINE TRAN

```

C

```

COMMON KB,
1 C, TV(10,181,10), TTV(10,181,10), BW(10,10,10), BTH(10,10),
2 W(10,10,10), TH(10,10), AVDIST(10), X(12),
3 IID(10), ASP(10,181), LVBC(10), NWS(10), KWS(10,10), MODCNT, IGWS RRST0
COMMON
1 NC, ID, I, NPASS, NM, IMPRUV, IBEST, ITRAN, MODE, ICAT,
2 NLV(10), VMODE(10), MBOD(10), N CORR
COMMON/BLOCK2/ INE(10), NE(10,10), INEMOD(10,10)
COMMON/BLOCK3/ MODVC(10,181), MODVCB(10,181), KCNT(10,10)
1 AVMODE(10,10)
COMMON/BLOCK4/ CC(10,10), IFORCE
DIMENSION
1 KCNT(10), JCNT(10), LWS(10)

```

C  
C

```

KILPAS = 0
KILL = 0
IGWS = 0
ITRAN = 1
NMD = NMODE(I)
4 KPAS = 1
10 DO 20 L = 1, NMD
  KCNT(L) = 1
20 CONTINUE
  NVECR = NLV(I)
  DO 50 K = 1, NVECR
    IF (NWS(I).EQ.0) GO TO 6
  NVA = NWS(I)

```

```

IF (NVA.GT.10) NVA = 10
DO 5 N1 = 1, NVA
IF (K.EQ.KWS(I,N1)) GO TO 50
5 CONTINUE
6 CONTINUE
DO 30 J = 1, ID
X(J) = TV(I,K,J)
80 CONTINUE
CALL DECIDE
KCNT(MODE) = KCNT(MODE) + 1
THR = 3.0
IF ( KCNT(MODE) .GT. 2 ) GO TO 31
LWS(MODE) = K
31 CONTINUE
DO 40 J = 1, ID
W(MODE,I,J) = (FLOAT(KCNT(MODE)-1)/FLOAT(KCNT(MODE))) * W(MODE,I,J)
+ TV(I,K,J)/(FLOAT(KCNT(MODE)))
THR = THR + W(MODE,I,J) * W(MODE,I,J)
80 CONTINUE
TH(MODE,I) = -THR/2.
90 CONTINUE
DO 51 JJ1=1,NMD
KCNT(JJ1) = KCNT(JJ1) - 1
51 CONTINUE
INCRS = 0
DO 70 L = 1, NMD
IF (KPAS.EQ.1) GO TO 60
IF (KCNT(L).LE.JCNT(L)) GO TO 70
80 JCNT(L) = KCNT(L)
INCRS = 1
70 CONTINUE
IF (INCRS.EQ.0) GO TO 80
KPAS = KPAS + 1
IF (KPAS.LE.10) GO TO 10
80 CONTINUE
KX1 = 0
DO 90 L = 1, NMD
IF (KCNT(L).GT.1) GO TO 85
IF ( KCNT(L) ,LT. 1 ) KILL = 1
NVA = NWS(I)
IF ( NVA ,EQ. 0 ) GO TO 107
DO 105 N1 = 1, NVA
IF ( KILL .EQ. 0 ) GO TO 106
IF ( KB .EQ. KWS(I,N1) ) GO TO 81
GO TO 105
106 CONTINUE
IF (LWS(L).EQ.KWS(I,N1)) GO TO 81
105 CONTINUE
107 CONTINUE
NWS(I) = NWS(I) + 1
IF (NWS(I).GT.10) GO TO 82
IF ( KILL .EQ. 0 ) GO TO 101

```

```

MNO = NWS(I)
KWS(I,MNO) = KB
WRITE (6,1005) KB, I
1005 FORMAT (1H, 13HRILLED VECTOR,13. 12M IN CATEGORY,13)
GO TO 81
801 CONTINUE
MNO = NWS(I)
KWS(I,MNO) = LWSRL)
81 CONTINUE
NMODE(I) = NMODE(I) + 1
IF (NMODE(I).LT.1) NMODE(I) = 1
82 IGWS = 1
GO TO 90
85 KX1 = KX1 + 1
DO 86 J = 1, ID
W(KX1,I,J) = W(L,I,J)
86 CONTINUE
TH(KX1,I) = TH(L,I)
INEMOD(I,KX1) = INEMOD(I,L)
AVMODE(I,KX1) = AVMODE(I,L)
CC(I,KX1) = CC(I,L)
90 CONTINUE
IF ( KILL .EQ. 0 ) GO TO 92
KILL = 0
KILPAS = KILPAS + 1
IF ( KILPAS .GT. 1 ) GO TO 92
GO TO 4
92 CONTINUE
IF (IGWS.EQ.0) GO TO 91
IF (NWS(I).GT.10) GO TO 91
MODCNT = MODCNT + 1
91 CONTINUE
RETURN
END
SUBROUTINE EVAL

```

C

```

COMMON KB,
1 C, TV(10,181,10), TTV(10,181,10), BW(10,10,10), BTH(10,10),
2 W(10,10,10), TH(10,10), AVDIST(10), X(12),
3 ID(10), ASP(10,181), LVEC(10), NWS(10), KWS(10,10), MODCNT, IGWS RR5EO
COMMON
1 NC, ID, I, NPASS, NM, IMPRUV, IBEST, ITRAN, MODE, ICAT,
2 NLV(10), VMODE(10), MBOD(10), N CORR
COMMON/BLOCK1/ NWSB(10), KWSB(10,10)
COMMON/BLOCK2/ INE(10), NE(10,10), INEMOD(10,10)
COMMON/BLOCK3/ MODVC(10,181), MODVCB(10,181), KCNTT(10,10),
1 AVMODE(10,10)
DIMENSION JI(10)

```

C  
C

```

ITRAN = 0
IMPRUV = 0

```

```

      NCORR = 0
      WRITE (6, 1001)
1001 FORMAT (1H, 54HTRUE CAT: VECTOR NO. TRUE MODE MACH. CAT.
1MODE/)
      DO 40 I = 1, NC
      JI(I) = 1
      NVECR = NLV(I)
      DO 30 K = 1, NVECR
      DO 19 J = 1, ID
      X(J) = TV(I,K,J)
20 CONTINUE
      CALL DECIDE
      IF (ICAT.NE.1) GO TO 20
      NCORR = NCORR + 1
      GO TO 30
20 WRITE (6,1002) I, K, MODVC(I,K), ICAT, MODE
1002 FORMAT( 5X, I2, 10X, I3, 10X, I2, 11X, I2, 7X, I2 )
      NE(I,ICAT) = NE(I,ICAT) + 1
      MJJ = MODVC(I,K)
      INEMOD(I,MJJ) = INEMOD(I,MJJ) + 1
30 CONTINUE
40 CONTINUE
      DO 42 JJJ = 1, NC
      DO 41 JJ=1,NC
      INE(JJJ) = INE(JJJ) + NE(JJJ, JJ)
41 CONTINUE
42 CONTINUE
      WRITE (6, 1003) NCORR
1003 FORMAT (1H0, 34H NO. CORRECT CLASSIFICATIONS, ...7, I6/)
      IF (NCORR.LE.IBEST) GO TO 90
      IMPRUV = 1
50 IBEST = NCORR
      DO 80 I = 1, NC
      NWSB(I) = NWS(I)
      IF (NWSB(I).EQ.0) GO TO 55
      NNN = NWSB(I)
      DO 54 N1 = 1, NNN
      KWSB(I,N1) = KWS(I,N1)
54 CONTINUE
55 CONTINUE
      NVECR = NLV(I)
      DO 61 KK=1,NVECR
61 MODVCB(I, KK) = MODVC(I, KK)
      MBOD(I) = VMODE(I)
      NMD = MBOD(I)
      DO 70 L = 1, NMD
      DO 60 J = 1, ID
      RW(L,I,J) = W(L,I,J)
60 CONTINUE
      BTH(L,I) = TH(L,I)
70 CONTINUE
80 CONTINUE

```

```

90 CONTINUE
WRITE (6,1004)
1004 FORMAT (/15X,12HERROR MATRIX)
WRITE (6,1005) ( JI(IJ),IJ=1,NC )
1005 FORMAT ( 5X,10(1X,12,2X) )
DO 100 I=1,NC
WRITE (6,1006) I,(NE(I,II),II=1,NC)
1006 FORMAT (2X,12,1X,10(14,1X))
100 CONTINUE
RETURN
END

```

#010	MODEL	A1 / 59	170	0.75	0.49	9.00	2	15
436		-55.5	147					
	VERT/VERT	101	0.0	50.0	0			
	HORIZ/HORIZ	101	0.0	50.0	0			
0.0		7.0	52.7-24.1	4.0	52.2-23.8	32.5		
0.5		6.0	52.7-25.7	6.0	53.7-23.8	53.7		
1.0		5.0	53.2-24.9	6.0	52.7-24.9	52.7		
1.5		6.0	53.2-25.1	6.0	52.7-25.2	0.5		
2.0		5.0	53.2-25.4	6.0	52.2-25.5	0.5		
2.5		6.0	53.7-25.1	6.0	52.2-25.5	1.0		
3.0		4.0	52.8-25.6	5.0	52.7-26.2	1.0		
3.5		5.0	52.7-26.1	5.0	52.3-26.4	51.3		
4.0		4.0	52.7-27.0	5.0	52.3-24.6	50.8		
4.5		4.0	54.2-26.7	5.0	51.8-24.9	52.8		
5.0		4.0	54.7-26.4	5.0	52.7-25.7	52.7		
5.5		5.0	54.2-26.4	6.0	52.3-26.3	0.5		
6.0		4.0	52.7-26.6	5.0	51.8-26.6	0.5		
6.5		3.0	53.7-26.8	6.0	52.3-26.4	0.5		
7.0		3.0	52.7-25.8	6.0	51.8-26.4	0.5		
7.5		3.0	53.2-26.5	6.0	51.8-25.9	0.5		
8.0		2.0	18.2-26.3	6.0	52.8-26.3	52.3		
8.5		3.0	52.8-25.9	4.0	51.8-25.2	1.0		
9.0		3.0	52.3-25.9	5.0	50.8-25.1	0.0		
9.5		2.0	52.8-26.1	5.0	52.3-25.4	0.0		
10.0		2.0	51.8-25.3	6.0	51.3-25.8	0.0		
10.5		3.0	54.2-25.1	5.0	51.3-25.3	0.0		
11.0		3.0	53.7-26.2	5.0	51.3-25.2	0.0		
11.5		3.0	55.7-26.0	5.0	50.8-24.4	0.5		
12.0		3.0	54.7-25.8	5.0	51.3-24.5	0.5		
12.5		3.0	51.8-24.8	6.0	50.8-25.3	1.0		
13.0		4.0	51.3-25.7	6.0	50.8-24.7	1.5		
13.5		3.0	51.3-26.1	7.0	50.8-24.8	1.0		
14.0		3.0	50.8-25.9	7.0	50.3-25.6	0.5		
14.5		3.0	50.3-25.5	7.0	50.8-25.0	1.0		
15.0		3.0	51.8-26.1	6.0	50.8-25.8	0.0		
15.5		3.0	50.3-25.8	5.0	51.3-24.8	0.0		
16.0		5.0	48.8-27.0	6.0	49.3-25.4	0.5		
16.5		3.0	50.3-26.5	5.0	50.3-26.2	0.5		
17.0		3.0	49.8-25.6	5.0	46.4-25.9	1.0		

17.5	4.0	49.8-26.6	6.0	49.8-25.9	0.5
18.0	3.0	49.3-26.0	6.0	49.8-26.3	0.5
18.5	3.0	48.8-26.3	6.0	49.3-25.6	0.0
19.0	3.0	48.3-25.9	5.0	44.9-26.2	1.0
19.5	3.0	51.8-25.5	6.0	48.8-26.0	1.0
20.0	3.0	49.3-25.1	3.0	45.4-25.2	0.5
20.5	2.0	51.8-25.5	4.0	48.8-25.6	0.0
21.0	2.0	52.2-25.2	4.0	48.8-24.9	1.5
21.5	2.0	49.3-24.5	4.0	48.8-24.4	0.0
22.0	3.0	47.8-25.4	4.0	48.3-24.8	0.0
22.5	3.0	47.3-24.3	5.0	47.8-24.7	0.5
23.0	3.0	47.8-24.9	5.0	47.3-24.9	1.0
23.5	3.0	46.8-24.9	4.0	46.8-24.6	0.5
24.0	3.0	46.3-25.0	5.0	46.8-24.8	1.5
24.5	3.0	47.3-26.1	4.0	46.8-24.7	1.0
25.0	3.0	46.8-25.2	4.0	46.8-25.0	0.5
25.5	2.0	46.8-25.9	4.0	46.3-24.1	0.5
26.0	2.0	47.8-25.1	4.0	46.8-23.7	1.0
26.5	2.0	45.3-24.8	4.0	45.8-24.6	1.0
27.0	2.0	46.3-24.6	4.0	45.8-24.3	0.0
27.5	2.0	45.3-24.5	4.0	44.8-24.4	0.0
28.0	4.0	49.8-25.0	4.0	45.3-24.5	0.5
28.5	3.0	44.8-26.2	4.0	44.8-24.6	0.5
29.0	2.0	46.8-26.0	5.0	45.3-25.2	1.0
29.5	2.0	45.3-25.7	4.0	44.8-25.1	1.0
30.0	2.0	45.3-25.7	4.0	44.4-25.3	0.0
30.5	2.0	43.8-24.3	4.0	43.4-24.9	0.5
31.0	3.0	44.3-24.9	4.0	42.9-25.4	0.5
31.5	3.0	44.8-25.0	4.0	43.9-25.4	0.0
32.0	3.0	43.9-25.9	5.0	43.4-25.6	0.5
32.5	2.0	43.4-25.1	4.0	43.4-25.1	0.5
33.0	2.0	43.4-24.9	5.0	42.9-24.4	0.5
33.5	3.0	46.3-24.2	4.0	42.4-23.7	0.5
34.0	2.0	43.9-24.4	4.0	41.4-23.3	1.0
34.5	2.0	43.4-24.5	5.0	41.9-23.7	0.5
35.0	2.0	42.9-24.8	5.0	41.4-24.0	1.0
35.5	2.0	41.4-25.7	4.0	41.9-23.6	1.0
36.0	2.0	42.4-24.4	4.0	41.9-23.5	1.5
36.5	2.0	41.9-24.4	4.0	41.0-23.2	0.9
37.0	2.0	40.9-23.8	4.0	40.0-23.4	0.9
37.5	2.0	40.4-23.6	4.0	40.4-23.6	0.5
38.0	3.0	40.4-24.8	4.0	40.9-24.1	0.0
38.5	3.0	39.9-24.7	3.0	40.4-23.8	0.0
39.0	2.0	39.0-24.6	3.0	40.4-23.3	1.4
39.5	2.0	38.0-24.8	3.0	39.9-23.1	1.9
40.0	2.0	38.5-23.8	4.0	38.9-23.5	1.4
40.5	2.0	39.4-24.4	4.0	38.4-23.8	0.0
41.0	2.0	38.0-23.9	4.0	38.4-23.5	1.9
41.5	3.0	38.0-24.2	4.0	38.0-23.0	0.5
42.0	3.0	37.5-24.0	4.0	37.0-23.5	0.5
42.5	3.0	37.4-24.0	4.0	37.5-23.9	0.9
43.0	3.0	37.0-23.3	4.0	36.5-24.1	1.5

38.5	3.0	36.5-23.4	4.0	36.0-23.0	0.0
39.0	3.0	36.0-23.1	4.0	36.0-22.2	0.5
39.5	3.0	35.5-22.4	4.0	36.0-21.7	0.5
40.0	3.0	34.5-22.5	4.0	34.5-22.2	0.5
40.5	3.0	34.5-23.1	4.0	35.0-22.2	0.5
41.0	3.0	34.5-22.8	4.0	35.0-21.0	0.5
41.5	3.0	33.5-22.0	4.0	34.5-20.8	1.0
42.0	3.0	33.6-22.9	3.0	34.1-20.9	0.5
42.5	3.0	34.5-22.0	4.0	33.0-22.0	2.0
43.0	3.0	33.5-23.0	3.0	33.0-21.4	0.5
43.5	3.0	32.6-21.5	3.0	32.6-20.4	0.0
44.0	3.0	32.6-22.0	3.0	32.6-20.6	0.0
44.5	3.0	31.6-21.6	3.0	32.6-20.9	0.5
45.0	3.0	31.6-21.7	3.0	32.1-20.8	0.0

0.50 50.0 1.0 9.00 2 8

416	MODEL	8/19	235	0.5	0.51
VER/VERT	101	0.0	50.0	0	
HORIZ/HORIZ	101	0.0	50.0	0	
0.0	2.0	18.5-14.7	2.0	18.5-14.5	0.0
0.5	2.0	18.0-15.6	2.0	18.5-15.1	0.5
1.0	2.0	18.0-16.0	2.0	19.0-17.3	0.5
1.5	2.0	19.0-16.5	2.0	18.0-20.6	0.5
2.0	2.0	18.0-17.3	2.0	18.5-27.7	0.5
2.5	2.0	19.0-20.2	1.0	0.0-23.4	0.5
3.0	2.0	18.5-22.6	2.0	19.5-18.6	1.0
3.5	2.0	18.5-26.4	2.0	18.5-15.5	0.0
4.0	2.0	20.1-31.6	2.0	18.5-15.0	0.0
4.5	2.0	18.0-38.2	2.0	18.0-14.9	1.0
5.0	2.0	18.5-36.6	2.0	18.5-15.5	0.5
5.5	2.0	19.0-30.4	2.0	18.0-16.9	0.5
6.0	2.0	17.5-28.7	2.0	17.5-18.8	0.0
6.5	2.0	17.5-29.7	2.0	18.0-19.6	0.0
7.0	2.0	17.5-34.3	2.0	18.0-19.6	17.5
7.5	2.0	17.4-35.0	1.0	0.0-15.3	18.5
8.0	3.0	21.1-36.6	1.0	0.0-14.6	17.5
8.5	2.0	20.0-38.7	2.0	17.5-14.2	2.5
9.0	2.0	18.5-34.5	2.0	17.0-14.5	0.0
9.5	3.0	18.5-30.8	2.0	18.0-15.3	0.5
10.0	2.0	18.0-30.3	2.0	16.4-15.9	1.1
10.5	3.0	18.5-34.3	2.0	18.0-15.6	0.0
11.0	2.0	17.5-36.9	2.0	18.0-14.8	0.0
11.5	2.0	16.9-38.7	2.0	18.0-14.8	17.5
12.0	2.0	16.4-39.4	2.0	18.0-14.1	1.1
12.5	2.0	18.0-35.4	1.0	0.0-14.3	0.0
13.0	2.0	17.4-30.9	1.0	0.0-14.9	0.0
13.5	2.0	15.5-30.8	2.0	16.5-15.3	0.0
14.0	2.0	14.9-31.2	2.0	17.0-15.4	0.6
14.5	3.0	19.6-34.5	2.0	15.9-14.8	0.6
15.0	3.0	19.5-36.8	2.0	16.9-14.8	0.5
15.5	3.0	20.6-37.4	2.0	16.9-15.2	0.0
16.0	3.0	20.0-36.1	2.0	17.4-15.5	0.5

16.5	2.0	18.0-31.7	2.0	17.4-16.1	1.1
17.0	2.0	18.0-30.5	2.0	18.0-16.5	0.0
17.5	2.0	19.0-30.1	2.0	19.0-17.0	0.5
18.0	2.0	18.5-34.4	2.0	18.5-17.0	0.5
18.5	2.0	18.5-36.0	2.0	15.4-16.7	0.0
19.0	3.0	24.2-35.6	2.0	15.4-17.2	0.0
19.5	2.0	18.5-35.1	2.0	15.9-17.7	0.0
20.0	2.0	18.0-34.5	2.0	15.9-17.6	0.0
20.5	2.0	16.9-31.1	2.0	17.4-17.2	0.0
21.0	2.0	16.4-30.5	2.0	17.4-16.7	1.0
21.5	2.0	17.5-29.6	2.0	17.5-16.2	0.0
22.0	2.0	16.9-29.6	2.0	16.9-16.2	0.0
22.5	2.0	16.4-29.6	2.0	17.5-15.7	0.0
23.0	2.0	17.0-29.0	2.0	17.5-15.6	0.5
23.5	2.0	16.9-28.4	2.0	18.0-15.2	0.0
24.0	2.0	16.9-28.2	1.0	0.0-15.2	0.0
24.5	2.0	17.0-27.3	2.0	17.0-15.2	0.0
25.0	2.0	17.5-27.4	2.0	17.5-15.2	0.0
25.5	2.0	17.5-26.9	2.0	16.4-15.0	0.0
26.0	2.0	16.4-26.7	2.0	16.4-15.0	0.0
26.5	2.0	16.5-26.4	2.0	16.4-15.3	0.5
27.0	2.0	16.4-26.5	2.0	17.5-15.4	0.5
27.5	2.0	16.4-25.7	2.0	16.5-15.3	0.5
28.0	2.0	16.5-26.0	2.0	16.5-15.7	0.0
28.5	2.0	15.9-25.3	2.0	17.5-15.4	0.5
29.0	2.0	16.5-24.7	2.0	17.0-15.9	0.0
29.5	2.0	16.5-24.4	2.0	17.0-16.1	0.0
30.0	2.0	15.9-24.2	2.0	16.5-16.2	0.0
30.5	2.0	16.0-23.9	2.0	16.5-16.1	0.5
31.0	2.0	15.4-23.4	2.0	15.4-15.7	0.5
31.5	2.0	17.0-23.0	2.0	15.9-15.5	0.0
32.0	2.0	14.9-23.1	2.0	15.4-15.5	0.5
32.5	2.0	14.9-23.0	2.0	16.0-15.2	0.5
33.0	2.0	14.9-22.9	2.0	15.9-15.1	1.0
33.5	2.0	15.5-22.4	2.0	16.0-15.3	0.5
34.0	2.0	14.9-21.8	2.0	15.4-15.4	0.0
34.5	2.0	15.4-22.1	2.0	17.0-15.1	0.5
35.0	2.0	14.9-21.5	2.0	15.4-15.7	0.5
35.5	2.0	16.0-20.9	2.0	15.4-15.7	0.0
36.0	2.0	15.5-20.7	2.0	15.4-15.8	0.5
36.5	2.0	15.5-20.3	2.0	14.3-15.7	0.6
37.0	2.0	14.4-20.0	2.0	14.9-15.5	0.0
37.5	2.0	14.3-19.6	2.0	14.4-16.0	0.6
38.0	2.0	13.8-19.8	2.0	14.4-15.5	0.5
38.5	2.0	13.8-19.3	2.0	14.9-15.7	0.0
39.0	2.0	14.3-19.1	2.0	14.9-15.8	0.5
39.5	2.0	14.3-18.5	2.0	13.8-15.6	0.0
40.0	2.0	15.4-18.1	2.0	14.4-15.5	0.5
40.5	2.0	14.3-18.2	2.0	14.4-15.6	0.5
41.0	2.0	15.4-18.0	2.0	14.9-15.9	1.0
41.5	2.0	14.9-18.0	2.0	13.8-16.0	0.0
42.0	2.0	14.3-17.1	2.0	14.3-16.3	0.0

42.5	2.0	13.8-17.0	2.0	13.8-16.5	0.5
43.0	2.0	13.8-16.8	2.0	13.8-15.7	0.0
43.5	2.0	13.8-16.6	2.0	13.8-16.0	0.0
44.0	2.0	13.8-16.6	2.0	13.9-16.4	0.5
44.5	2.0	12.8-16.5	2.0	13.8-16.1	0.5
45.0	2.0	13.3-16.4	2.0	13.3-16.6	0.0
45.5	2.0	13.8-15.8	2.0	13.9-16.5	0.5
46.0	2.0	13.8-15.8	2.0	13.3-16.4	0.5
46.5	2.0	13.9-15.6	2.0	13.3-17.4	0.0
47.0	2.0	13.3-15.6	2.0	13.3-17.3	0.0
47.5	2.0	12.8-15.1	2.0	12.8-17.7	0.0
48.0	2.0	12.8-14.8	2.0	12.8-17.4	0.5
48.5	2.0	12.8-15.5	2.0	12.8-17.7	0.0
49.0	2.0	12.8-15.2	2.0	12.3-18.3	0.5
49.5	2.0	12.8-15.1	2.0	12.9-18.9	1.5
50.0	2.0	12.8-14.8	2.0	12.3-18.9	0.5

50.0 50.0 1.0  
 MODEL 66 9.00 2 20

393	-55.9	203	0.5	0.49	
VERT/VERT	101	0.0	50.00	0	
HORIZ/HORIZ	101	0.0	50.00	0	
0.0	2.0	7.9-22.8	2.0	6.9-22.4	1.0
0.5	2.0	7.9-22.8	2.0	7.9-22.7	0.0
1.0	2.0	7.4-22.7	2.0	7.4-23.5	0.0
1.5	2.0	7.4-24.0	2.0	7.9-25.1	0.5
2.0	2.0	7.9-24.7	2.0	6.9-27.3	1.0
2.5	2.0	7.9-26.1	2.0	7.9-26.9	0.4
3.0	2.0	7.9-26.8	3.0	11.4-27.1	7.4
3.5	2.0	7.9-28.0	3.0	10.4-27.4	0.0
4.0	2.0	7.9-27.0	2.0	7.9-28.1	0.5
4.5	2.0	7.9-28.0	2.0	7.9-26.8	7.4
5.0	2.0	7.9-28.2	2.0	7.9-24.9	7.9
5.5	2.0	9.9-26.7	2.0	7.4-23.8	7.9
6.0	2.0	11.4-27.9	2.0	7.9-24.1	8.9
6.5	2.0	9.9-28.3	2.0	7.9-23.9	7.4
7.0	2.0	10.4-27.6	2.0	7.9-24.7	7.9
7.5	2.0	9.4-28.0	2.0	7.4-26.6	6.4
8.0	2.0	8.9-27.3	2.0	7.9-27.4	1.0
8.5	2.0	9.4-28.0	2.0	7.0-27.5	0.5
9.0	2.0	9.9-27.8	2.0	7.0-27.5	0.0
9.5	2.0	10.4-27.8	2.0	6.5-27.9	1.0
10.0	2.0	1.9-28.1	2.0	7.0-27.2	0.0
10.5	2.0	11.9-27.8	2.0	7.4-26.9	1.0
11.0	2.0	8.9-27.4	2.0	7.0-26.8	1.0
11.5	2.0	10.9-27.7	2.0	7.5-27.0	0.5
12.0	2.0	10.4-27.0	2.0	7.0-26.6	1.0
12.5	2.0	9.9-28.1	2.0	7.0-26.6	0.0
13.0	2.0	10.4-28.0	2.0	6.4-26.6	1.0
13.5	2.0	10.4-27.8	2.0	6.0-26.5	0.5
14.0	2.0	12.4-27.2	2.0	6.5-26.5	0.5
14.5	2.0	11.9-28.0	3.0	11.9-26.3	0.0
15.0	2.0	10.9-28.0	3.0	11.4-27.0	0.0

15.5	2.0	11.4-27.7	3.0	10.9-26.3	1.0
16.0	2.0	10.4-27.6	2.0	6.5-27.3	0.5
16.5	2.0	11.4-27.7	2.0	6.0-27.0	1.0
17.0	3.0	10.4-28.0	2.0	6.0-27.2	0.5
17.5	2.0	10.9-28.3	2.0	6.0-27.5	0.8
18.0	2.0	9.4-28.0	2.0	6.5-27.5	0.5
18.5	2.0	10.4-28.3	2.0	6.5-27.3	1.0
19.0	2.0	9.4-27.5	2.0	6.0-27.4	1.0
19.5	2.0	8.4-28.2	2.0	6.0-27.1	0.5
20.0	2.0	9.4-27.9	2.0	6.0-26.3	0.0
20.5	2.0	10.4-27.8	2.0	6.5-27.5	0.5
21.0	2.0	11.4-27.5	2.0	6.5-26.6	0.0
21.5	2.0	9.4-27.7	2.0	6.5-26.7	0.5
22.0	2.0	9.9-28.1	2.0	6.0-26.5	0.0
22.5	2.0	9.9-28.5	2.0	6.0-26.5	0.5
23.0	2.0	9.9-27.5	2.0	6.0-27.2	0.5
23.5	2.0	8.4-27.7	2.0	6.0-27.5	0.0
24.0	2.0	9.9-28.3	2.0	6.0-27.3	0.5
24.5	2.0	9.9-28.0	1.0	6.0-27.5	0.0
25.0	2.0	10.9-27.5	2.0	6.0-27.1	0.5
25.5	2.0	9.9-28.0	2.0	10.9-26.3	1.0
26.0	2.0	10.4-28.1	3.0	10.9-26.3	0.5
26.5	2.0	10.9-27.8	1.0	6.0-25.8	0.5
27.0	2.0	10.4-27.5	2.0	10.9-26.3	0.0
27.5	2.0	9.9-27.3	3.0	8.9-26.0	1.0
28.0	2.0	9.4-26.8	2.0	5.0-26.8	0.5
28.5	2.0	8.4-27.7	2.0	5.5-26.2	1.0
29.0	2.0	10.4-26.7	2.0	5.0-26.3	1.0
29.5	2.0	10.9-27.6	2.0	5.0-26.6	1.5
30.0	2.0	10.4-26.8	2.0	5.0-26.1	0.5
30.5	2.0	10.4-26.4	2.0	5.0-27.4	1.5
31.0	2.0	10.9-26.7	2.0	5.0-26.8	0.5
31.5	2.0	9.9-26.8	1.0	6.0-26.7	1.0
32.0	2.0	9.9-26.6	1.0	6.0-26.4	0.5
32.5	2.0	10.4-26.0	1.0	6.0-25.5	0.5
33.0	2.0	8.9-26.2	1.0	6.0-25.0	1.0
33.5	1.0	6.0-25.6	1.0	6.0-24.4	1.5
34.0	2.0	9.4-26.4	1.0	6.0-24.6	0.0
34.5	1.0	6.0-26.1	1.0	6.0-24.7	0.5
35.0	1.0	6.0-25.6	2.0	5.5-24.6	0.0
35.5	1.0	6.0-26.1	2.0	3.5-25.1	0.5
36.0	1.0	6.0-26.2	2.0	5.0-26.2	0.0
36.5	1.0	6.0-26.6	2.0	4.5-25.2	0.5
37.0	1.0	6.0-25.1	1.0	6.0-25.8	0.5
37.5	1.0	6.0-25.5	1.0	6.0-24.0	1.0
38.0	1.0	6.0-25.7	1.0	6.0-23.9	0.5
38.5	1.0	6.0-24.8	1.0	6.0-23.4	0.5
39.0	1.0	6.0-25.2	1.0	6.0-23.5	0.0
39.5	1.0	6.0-25.2	1.0	6.0-23.9	1.0
40.0	1.0	6.0-25.1	1.0	6.0-23.5	0.5
40.5	1.0	6.0-25.9	1.0	6.0-24.2	1.0
41.0	1.0	6.0-26.0	2.0	4.5-25.3	1.0

41.5	1.0	0.0-25.8	2.0	4.0-25.1	0.0
42.0	1.0	0.0-25.4	1.0	0.0-25.3	1.5
42.5	1.0	0.0-25.6	1.0	0.0-23.6	0.0
43.0	1.0	0.0-24.6	1.0	0.0-23.9	0.5
43.5	1.0	0.0-24.9	1.0	0.0-22.4	0.5
44.0	1.0	0.0-24.2	1.0	0.0-22.2	2.0
44.5	1.0	0.0-23.2	1.0	0.0-21.5	1.0
45.0	1.0	0.0-22.8	1.0	0.0-21.9	1.0
45.5	1.0	0.0-23.4	1.0	0.0-22.1	0.0
46.0	1.0	0.0-22.7	1.0	0.0-20.9	0.0
46.5	1.0	0.0-23.1	1.0	0.0-21.7	0.0
47.0	1.0	0.0-23.7	1.0	0.0-22.0	0.0
47.5	1.0	0.0-22.3	1.0	0.0-22.5	0.5
48.0	1.0	0.0-22.6	1.0	0.0-21.6	0.5
48.5	1.0	0.0-23.6	1.0	0.0-20.8	0.0
49.0	1.0	0.0-22.7	1.0	0.0-21.3	0.5
49.5	1.0	0.0-21.8	1.0	0.0-21.6	0.0
50.0	1.0	0.0-21.7	1.0	0.0-20.5	1.0
2	1	1	1		
2	1	1			
2		1	1		

*MISSION*  
*of*  
*Rome Air Development Center*

*RADC plans and conducts research, exploratory and advanced development programs in command, control, and communications (C<sup>3</sup>) activities, and in the C<sup>3</sup> areas of information sciences and intelligence. The principal technical mission areas are communications, electromagnetic guidance and control, surveillance of ground and aerospace objects, intelligence data collection and handling, information system technology, ionospheric propagation, solid state sciences, microwave physics and electronic reliability, maintainability and compatibility.*

