

AD-A033 710

ROME AIR DEVELOPMENT CENTER GRIFFISS AFB N Y
TRANSIENT SUPPRESSION MODIFICATION FOR INSTRUMENT LANDING SYSTEM--ETC(U)
OCT 76 C W PAPROCKI
RADC-TR-76-265

F/0 1/2

UNCLASSIFIED

NL

1 of 1
AD
A033710



ADAC033710

RADC-TR-76-265
In-house Report
October 1976

12
B.S.



TRANSIENT SUPPRESSION MODIFICATION
for
INSTRUMENT LANDING SYSTEM AN/GRN-27(v)
(Solid State Instrument Landing System (SSILS))

Chester W. Paprocki

Approved for Public Release.
Distribution Unlimited.

ROME AIR DEVELOPMENT CENTER
AIR FORCE SYSTEMS COMMAND
GRIFFISS AIR FORCE BASE, NEW YORK 13441

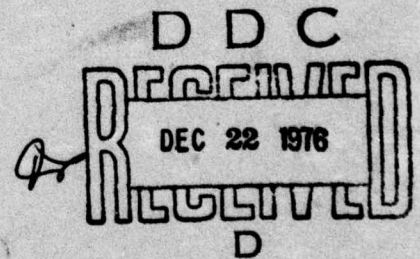

PREFACE

The material for this report was collected and prepared under Job Order No. 404L1401. The effort was conducted at the request of the Electronics Systems Division (ESD) TRACALS System Project Office (SPO) in response to direction of the Air Staff to "in-house study, design and test equipment which would reduce the lightning-induced outages of the Solid State Instrument Landing System (SSILS) AN/GRN-27(v)."

The author wishes to acknowledge the assistance and support received from Captain Rudolf Konegen, SPO Program Manager, Joseph J. Polniaszek, Jr., and all the many other people who helped in performing this task.

This report has been reviewed by the Office of Information, RADC, and approved for release to the National Technical Information Service (NTIS). At NTIS, it will be available to the general public, including foreign nations.

This report has been reviewed and is approved for publication.

APPROVED: *Thomas Maggio*

THOMAS MAGGIO
Chief, Surveillance Equipment Development Branch
Surveillance Division

APPROVED: *Bobbie J. Landers*

BOBBIE J. LANDERS, Lt Col, USAF
Assistant Division Chief
Surveillance Division

FOR THE COMMANDER:

John P. Huss

JOHN P. HUSS
Acting Chief
Plans Office

Do not return this copy. Retain or destroy.

UNCLASSIFIED

SECURITY CLASSIFICATION OF THIS PAGE (When Data Entered)

REPORT DOCUMENTATION PAGE		READ INSTRUCTIONS BEFORE COMPLETING FORM	
1. REPORT NUMBER RADC-TR-76-265 ✓	2. GOVT ACCESSION NO.	3. RECIPIENT'S CATALOG NUMBER 9	
4. TITLE (and Subtitle) TRANSIENT SUPPRESSION MODIFICATION FOR INSTRUMENT LANDING SYSTEM AN/GRN-27(v) (Solid State Instrument Landing System (SSILS)).		5. TYPE OF REPORT & PERIOD COVERED Final Rept.	
7. AUTHOR(s) Chester W. Paprocki		6. PERFORMING ORG. REPORT NUMBER N/A	
		8. CONTRACT OR GRANT NUMBER(s) N/A	
9. PERFORMING ORGANIZATION NAME AND ADDRESS Rome Air Development Center (OCDC) ✓ Griffiss AFB NY 13441		10. PROGRAM ELEMENT, PROJECT, TASK AREA & WORK UNIT NUMBERS PE3 35114F 404L1401	12 48 p.
11. CONTROLLING OFFICE NAME AND ADDRESS Same		12. REPORT DATE Oct 1976	
		13. NUMBER OF PAGES 40	
14. MONITORING AGENCY NAME & ADDRESS (if different from Controlling Office) Same		15. SECURITY CLASS. (of this report) Unclassified	
		15a. DECLASSIFICATION/DOWNGRADING SCHEDULE N/A	
16. DISTRIBUTION STATEMENT (of this Report) Approved for Public Release. Distribution Unlimited.			
17. DISTRIBUTION STATEMENT (of the abstract entered in Block 20, if different from Report) Same			
18. SUPPLEMENTARY NOTES None			
19. KEY WORDS (Continue on reverse side if necessary and identify by block number) Transient Spark Gaps SSILS Transorb Lightning			
20. ABSTRACT (Continue on reverse side if necessary and identify by block number) The Solid State Instrument Landing System (SSILS) AN/GRN-27(v) was experiencing excessive outages during lightning storms, which are the periods of time in which the ILS is in the most critical demand. An in-house study was made of the source and type of transients that were affecting the system. Protective methods and devices were evaluated and protective circuitry was designed. The characteristics of the transient and design criteria for a suitable modification are discussed in this report.			

DD FORM 1 JAN 73 1473 EDITION OF 1 NOV 65 IS OBSOLETE

UNCLASSIFIED

SECURITY CLASSIFICATION OF THIS PAGE (When Data Entered)

309050

1/B

UNCLASSIFIED

SECURITY CLASSIFICATION OF THIS PAGE(When Data Entered)

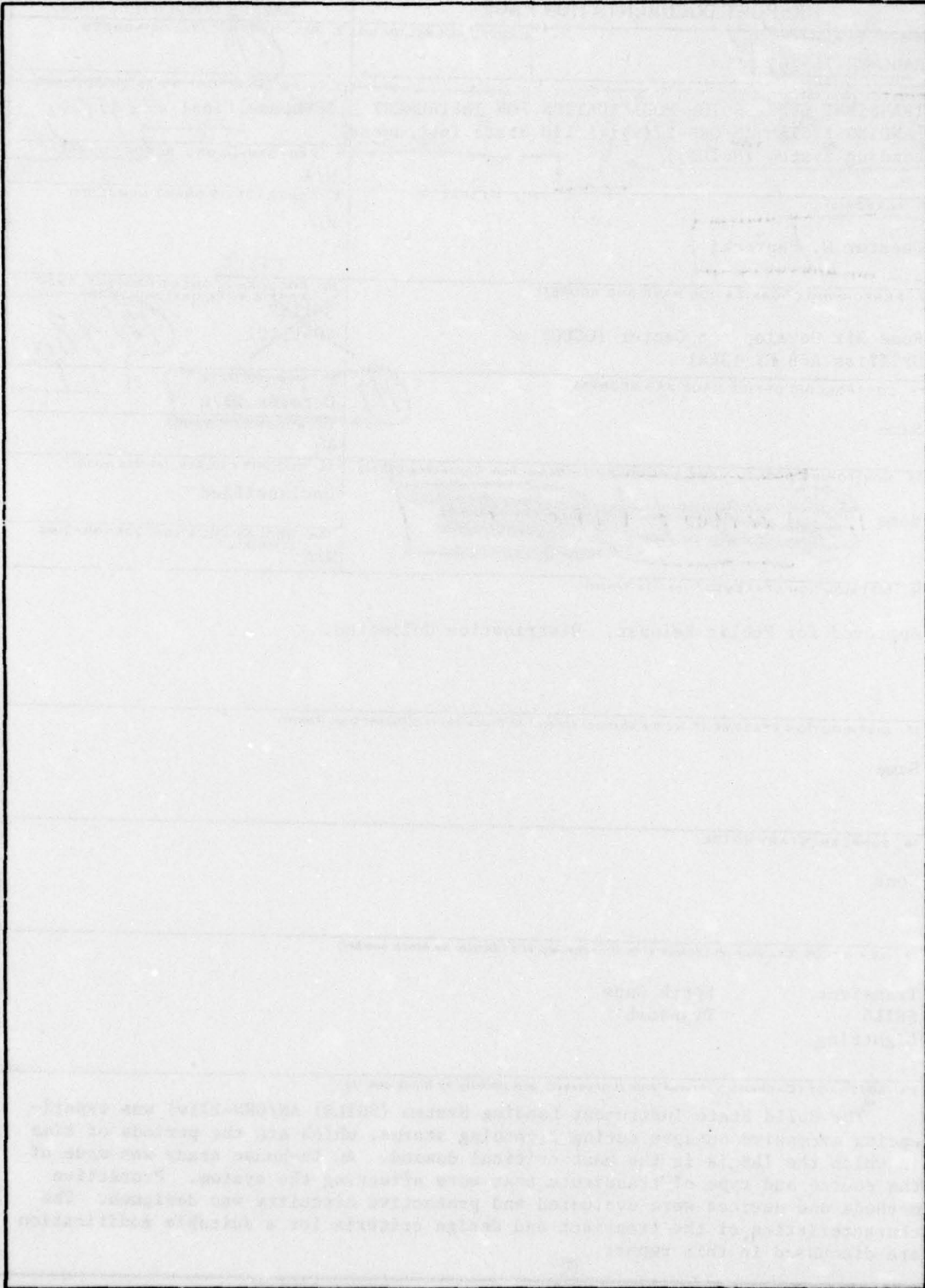

UNCLASSIFIED

SECURITY CLASSIFICATION OF THIS PAGE(When Data Entered)

30000E

TABLE OF CONTENTS

Contents	<u>PAGE</u>
I. Introduction	1
II. Detail Study of the Lightning Problem Type of Protection Needed	2 2
III. An Analysis of the SSILS	6
IV. Available Protection Devices	8
A. Spark Gaps	8
B. Diodes	9
C. Metal Oxide Varistors (MOV's)	9
D. Silicon Controlled Rectifiers (SCR's)	9
E. Hybrid Devices	9
V. Lightning Transient Protection for the SSILS	15
A. Data Line Protection	15
B. Power Line Protection	26
VI. Lightning Simulator	30
VII. Field Testing	31
VIII. Conclusions and Recommendations	32

	White Section <input checked="" type="checkbox"/>	
	Buff Section <input type="checkbox"/>	
A		

D D C

RECEIVED

DEC 22 1976

D

LIST OF ILLUSTRATIONS

<u>FIGURE</u>		<u>PAGE</u>
1	Isoceraunic Map of the United States	3
2	Distribution of Peak Initial Stroke Current for Lightning Flashes to Buried Cables	4
3	Test Waveform for Lightning Induced Voltages on Buried Control Cables	6
4	Instrument Landing System AN/GRN-27(v)	7
5	Basic Arrestor Circuit	16
6	Current Through Protector Circuit	16
7	RADC-X7518629, Transient Suppressor Schematic Diagram-Monitor, Radio Frequency, MC-9026/GRN-27(v)	17
8	RADC-X7518630, Transient Suppressor Schematic Diagram-Beacon Set, Radio, AN/GRN-26	18
9	RADC-X7518631, Transient Suppressor Schematic Diagram-Control-Indicator, C-8826/GRN-27(v)	19
10	RADC-X7518632, Transient Suppressor Schematic Diagram-Localizer Station, AN/GRN-27(v)	20
11	RADC-X7518633, Transient Suppressor Schematic Diagram-Glideslope Station, AN/GRN-27(v)	21
12	Modified Arrestor Circuit	23
13	Transient Effects Using a Common Ground	24
14	Transient Effects Using Separate Grounds	24
15	Wired Circuit, Transient Protection for Marker Beacon	25
16	Wired Circuit, Transient Protection for Glideslope	26
17	RADC-X7518650, Transient Suppressor Modification - Equipment Shelters, Instrument Landing System AN/GRN-27(v)	27
18	Prime Power Line Protection Circuit, Glideslope and Localizer Stations	28
19	Lightning Simulator	29

LIST OF ILLUSTRATIONS (Continued)

<u>FIGURE</u>		<u>PAGE</u>
20	Output Pulse From Lightning Simulator (25 ohm load)	30
21	Typical Test Set-up At Operational Facility - Lightning Transient Test	32
22	Test Pulse Sequence - Lightning Transient Test	33

Master copies of these Figures available in RADC Drawing Library

Figure 7	RADC-X7518629, Transient Suppressor Schematic Diagram-Monitor, Radio Frequency, MC-9026/GRN-27(v)
Figure 8	RADC-X7518630, Transient Suppressor Schematic Diagram-Beacon Set, Radio AN/GRN-26
Figure 9	RADC-X7518631, Transient Suppressor Schematic Diagram-Control Indicator, C-8826/GRN-27(v)
Figure 10	RADC-X7518632, Transient Suppressor Schematic Diagram-Localizer Station, AN/GRN-27(v)
Figure 11	RADC-X7518633, Transient Suppressor Schematic Diagram-Glideslope Station, AN/GRN-27(v)
Figure 17	RADC-X7518650, Transient Suppressor Modification-Equipment Shelters, Instrument Landing System AN/GRN-27(v)

LIST OF TABLES

<u>TABLE</u>		<u>PAGE</u>
I	Mean Number of Thunderstorm Days for McDill, McGuire and Dover AFB's	5
II	Transient Energy Levels	5
III	Wire Interconnection Via Transient Suppression Box, Remote Monitor Station, Marker Beacon Station, Glideslope Station, Localizer Station and Far Field Monitor	10

I. INTRODUCTION:

The Instrument Landing System AN/GRN-27(v) was designed for worldwide use during Category II weather conditions at intermediate and large airports. The major subsystems of the landing system are dispersed around and often off the airport proper and are interconnected by a network of commercial grade telephone lines. These telephone lines frequently are miles long and routed through various telephone equipment and switching terminals. The interconnecting telephone wires, power wires and antenna arrays of the system all act as transmission lines for induced transients, which may have an adverse effect on the electronics of the landing system.

Shortly after the AN/GRN-27, commonly referred to as the SSILS (Solid State Instrument Landing System), was being commissioned (summer 1973) a high number of disruptions and operational failures were experienced. These failures often occurred during periods of electrical atmospheric disturbances, which were the periods when the ILS was most needed. A study program was initiated to find the reason for the failures and to provide a method of protection. Since there was no evidence of direct lightning hits, it was determined that transients due to electromagnetic disturbances, a result of nearby lightning activity, were exceeding the voltage rating of interface parts of the SSILS.

An analysis was made to determine the severity of the lightning transient problem. Since the behavior of lightning is unpredictable, a set of transient characteristics was developed. The available protection devices were then evaluated to provide circuit protection to isolate the sensitive ILS components from the destructive transients. A multi-stage protection circuit was designed using spark gap type devices and zener diodes. These protection circuits were

breadboard constructed to allow evaluation.

Tests on a hot mock-up of the SSILS indicated that changes could be made to the protection circuit to improve the filter action and enhance the life of the spark gaps. The modified protection circuits were again tested in an operational environment. These tests were conclusive enough to serve as a base for retrofit of the SSILS.

II. DETAIL STUDY OF THE LIGHTNING PROBLEM:

Type of Protection Needed

Evidence of SSILS failures was first observed on two systems: one installed in New Jersey and another in Delaware. A view of an isoceraunic map (Figure 1) of the United States shows the incidence of lightning in that area to be comparatively low when related to other parts of the CONUS. The worst case condition exists in the Tampa, Florida area with 100 thunderstorm days per year. The monthly distribution obtained from the Worldwide Airfield Climatic Data Manuals is presented in Table I for MacDill, McGuire and Dover AFB's. An empirical factor of up to 0.5 is used to convert to the number of strokes per square mile at level ground. Using the figures in Table I, it may be determined that 42 strokes/mile²/year can be predicted for the MacDill AFB area. In comparison, approximately 15 strokes/mile²/year may be expected at McGuire and Dover AFB.

The behavior of lightning is unpredictable. However, the United States Weather Bureau has accumulated statistical data from which one is able to predict the frequency of occurrence of lightning. Bell Laboratories personnel have also calculated, as shown in Figure 2, a distribution of peak initial stroke currents for lightning flashes to buried cables (Reference 2). The numbers presented in the figure give the reader a feel for the magnitude of

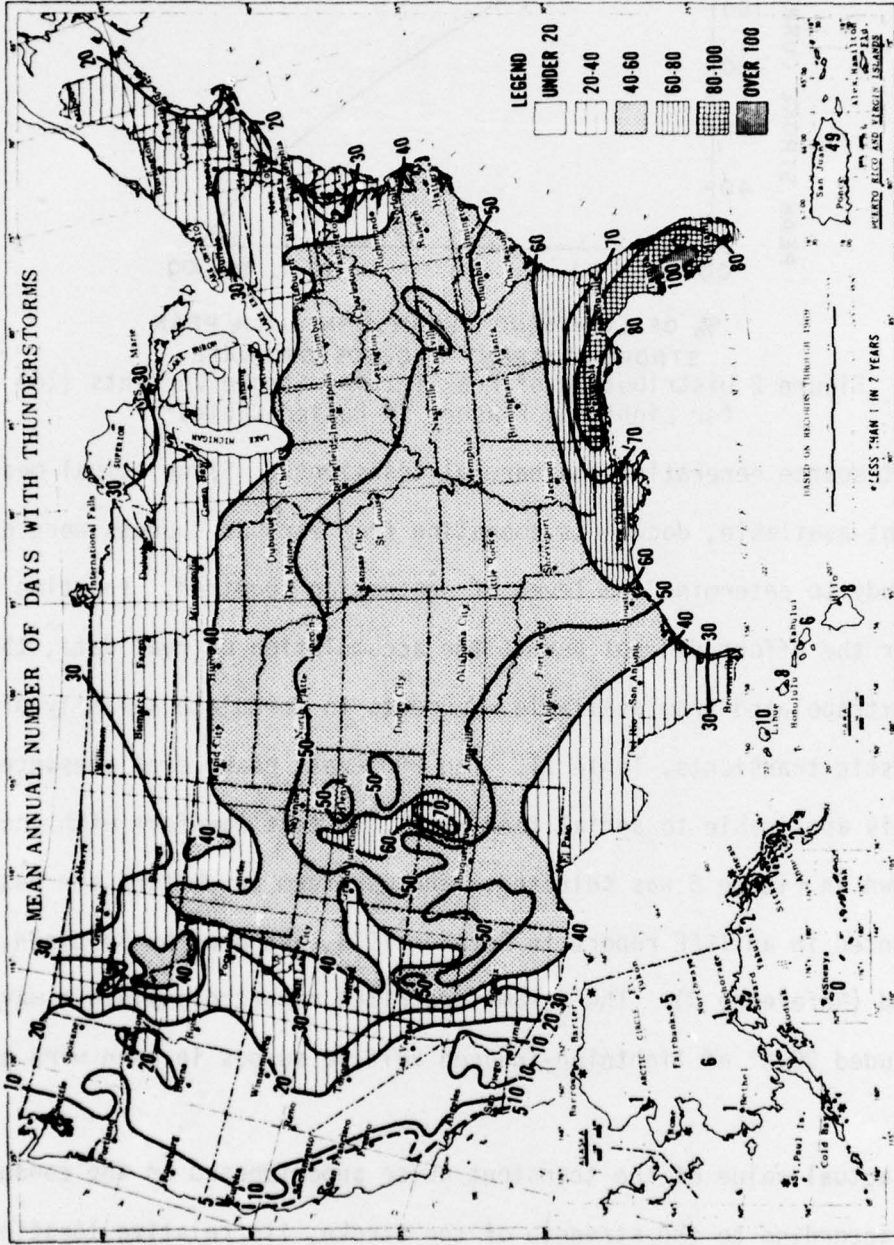
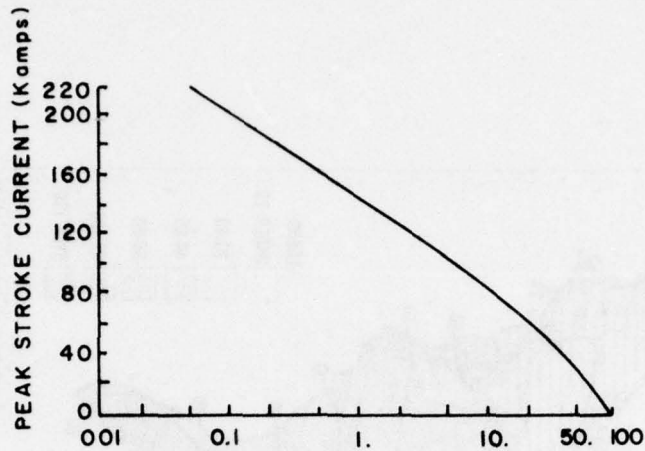

Figure 1 Isoceraunic Map of United States



**% OF LIGHTNING FLASHES IN WHICH PEAK
STROKE CURRENT EXCEEDS ORDINATE**
Figure 2 Distribution of Peak Initial Stroke Currents (10)
for Lightning Flashes to Buried Cables*

the current source generating the harmful transients. Since actual measured data was not available, documents emanating from various sources were evaluated in this study to determine the level of protection required. The time frame allowed for the effort did not permit the accumulation of real data, therefore, data was extrapolated from available documents to formulate a family of characteristic transients, Table II. The 2000-volt peak level presented in the table is applicable to aerial feed wires. A test waveform with characteristics shown in Figure 3 was selected. The waveform parameters are based on data presented in an IEEE report in October 1973, authored by Bennison, Ghazi and Ferland (Reference 3). The parameters cited reportedly yield a waveform which included 99.8% of lightning-induced voltage surges in open wire and cable.

The actual value of the transient pulse superimposed on the conductors will vary according to the strength of the stroke, its relative location to a conductor, the conductivity of surrounding soil and low impedance path to

*From Wire Journal, Jan. 1973, "Lightning Induced Current Surges on Buried Multicoaxial Cable System," Douglass, D. A. Bell Laboratories

TABLE I

MEAN NUMBER OF THUNDERSTORM DAYS

	<u>MACDILL AFB</u>	<u>MCGUIRE AFB</u>	<u>DOVER AFB</u>
J	1.1	.1	.2
F	1.9	.4	.3
M	2.6	.7	1.2
A	4.2	2.3	2.6
M	5.9	4.6	5.7
J	13.1	5.5	5.6
J	19.3	6.7	6.6
A	18.2	4.7	5.7
S	12.1	2.3	2.3
O	2.8	1.1	1.1
N	1.1	.2	.4
D	.7	0.0	.1
ANNUAL	83.0	28.6	31.8

Reference -

Worldwide Airfield Climatic Data, USAF Environmental Technical Application Center, Vol. VIII PARTS 6 & 7

TABLE II

TRANSIENT ENERGY LEVELS

<u>Peak Voltage</u>	<u>Pulse Width</u>	<u>Rise Time</u>	<u>Decay Time</u>	<u>Approx. Energy Level</u>
2,000	250 μ sec	4 μ sec	200 μ sec	33 Joules
1,000	1,000 μ sec	10 μ sec	1,000 μ sec	33 Joules
400	4,000 μ sec			25 Joules
1,000	100 μ sec at 100 Hz rate			3.3 Joules

true ground. In the case of the SSILS, the actual magnitudes of the damaging transients were not measured. The values presented in Table II exceed the breakdown voltage of the interface components of the SSILS and encompass the characteristics of known lightning-induced transient pulses, therefore, it was adopted as a guide for purposes of this study.

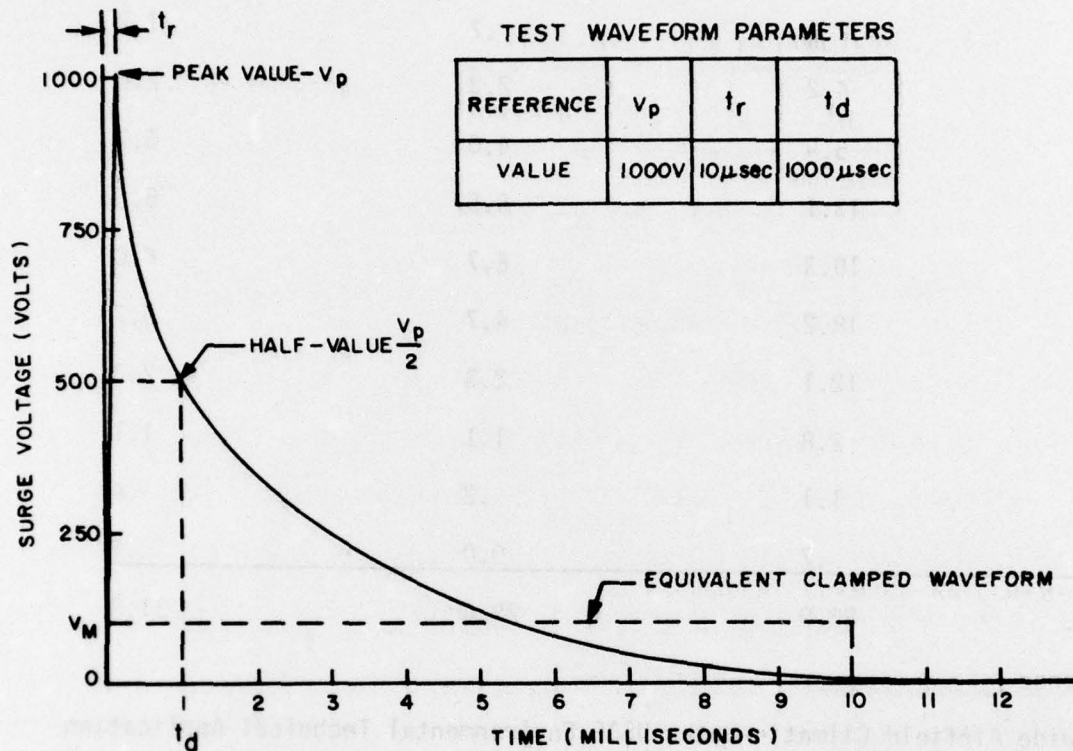

Figure 3 Test Waveform for Lightning-induced Voltages on Buried Control Cables

III. AN ANALYSIS OF THE SSILS:

A conclusion was reached, early in the analysis, that total elimination of damage potential to the SSILS would not be practical. The installation criteria for a landing system (see Figure 4) are such that subsystems such as the localizer and glideslope stations attract lightning. Most of the inter-connecting electrical cables around the airport supporting the ILS are buried telephone lines. While these buried cables are normally protected against

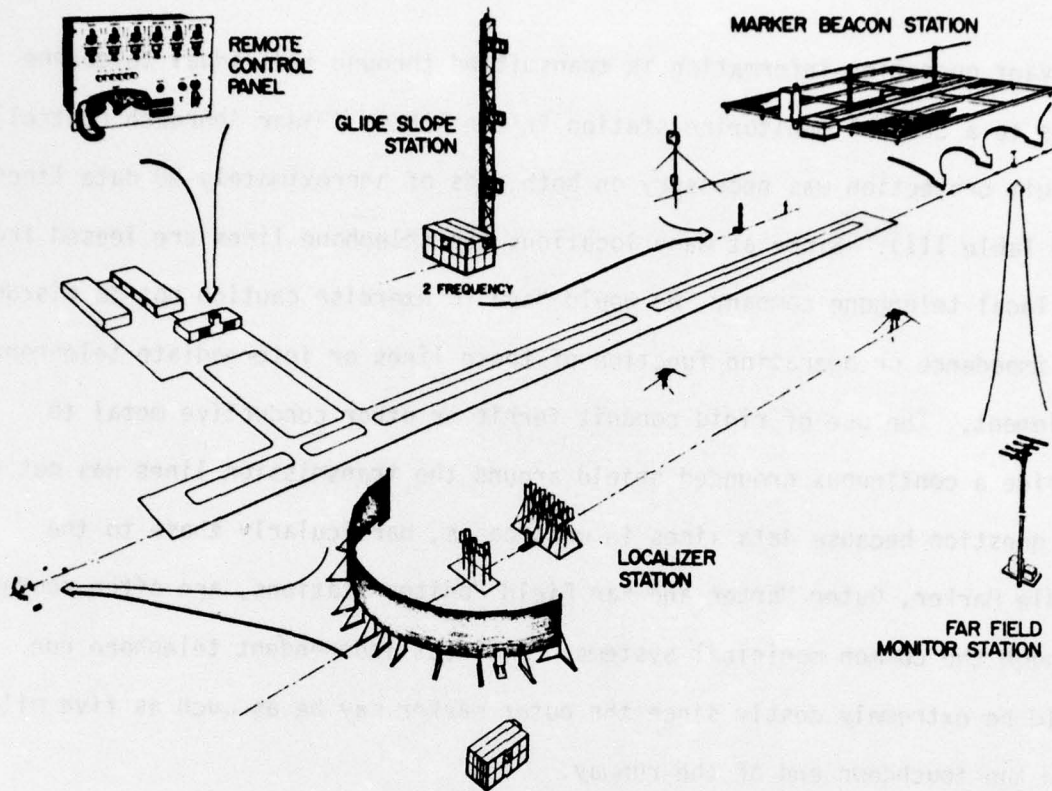

Figure 4 Instrument Landing System AN/GRN-27(v)

direct lightning strokes, they are frequently subjected to transients caused by strokes which hit the earth's surface nearby. The current from these strokes in seeking the path of least resistance to true ground may travel long distances along a communications cable. Since total shielding is not available, the pulses are coupled to the data lines and carried directly into the electronic circuitry of the equipment. When the voltage level of the pulse exceeds the withstand value of the interface components, catastrophic failures occur. A design goal to achieve 95% protection was established for this program.

The AN/GRN-27 SSILS has sensitive monitoring circuitry at each of the radiating subsystems. The performance status of these monitors and other

relevant operating information is transmitted through individual telephone lines to a central monitoring station in the PARCON (Radar Approach Control). Circuit protection was necessary on both ends of approximately 50 data lines (see Table III). Since at many locations the telephone lines are leased from the local telephone company, we would have to exercise caution not to disrupt the impedance or operating function of these lines or intermediate telephone equipment. The use of rigid conduit ferris or other conductive metal to provide a continuous grounded shield around the transmission lines was out of the question because data lines in most cases, particularly those to the Middle Marker, Outer Marker and Far Field Monitor Stations, are often routed through the common municipal systems. A direct independent telephone run would be extremely costly since the outer marker may be as much as five miles from the touchdown end of the runway.

IV. AVAILABLE PROTECTION DEVICES

It was determined that protection would be made at the equipment level as close as possible to the utilities/ILS transition point. Data line protection values were determined and appear in Table III. Some of the available protection devices evaluated are:

A. Spark Gaps are composed of two metal electrodes separated by a dielectric. The gap may be sealed in a glass or ceramic container and the dielectric may be air or inert gas. Judicious selection of gases provides different ionization levels as a voltage is applied. Spark gaps are very reliable low cost devices. They have a very low voltage drop during the conduction state and have a high current carrying capability. Operation is bilateral. Among the disadvantages are the requirement for a relatively high spark over voltage and the requirement that the arc must be extinguished by

removing the voltage.

B. Diodes are available under various names depicting specific application. Some examples are the Zener Diode used to clip a transient or voltage and hold it to a rated voltage level: Forward Conducting Diodes include the standard silicon and germanium types used to bypass undesired signals: Controlled Avalanche Rectifiers are silicon diode rectifiers with controlled reverse characteristics: "TransZorb," a trade name used by General Semiconductor Industries, Inc., are zener diodes having an extremely fast response time. Diodes are generally small and have a wide assortment of characteristics which make them suitable for line/circuit interface application. They may be selected to monitor critical voltage levels with extremely fast (2.0 nanoseconds) response. Diodes have the disadvantage of not being able to tolerate large voltage surges for long periods of time.

C. Metal Oxide Varistors (MOV's), a product of the General Electric Company, are similar in characteristics to bilateral coupled zener diodes. Their response time is in the order of 1.0 to 3.0 μ seconds, dependent on the voltage and rise time of the pulse. The current carrying capability of the MOV is better than that of a diode, but not as good as the spark gap.

D. Silicon Controlled Rectifiers (SCR's) can be used as a unipolar spark gap to suppress transients. They have excellent surge-current ratings but they must be triggered by an external source. The SCR is a relatively expensive device.

E. Hybrid Devices are available in a variety of sizes and ratings, all prepackaged. These are normally multistage devices using diodes in one stage to reduce the steep wave front of the transient by clamping it at a given level; a second stage may contain a high current dissipating device such as a

TABLE III

WIRE INTERCONNECTION VIA TRANSIENT SUPPRESSOR BOX REMOTE MONITOR STATION

Wire From	Signal Name	Wire To	Operating Voltage (Volts)	Remarks
D1TB1		E1TB-2		OUTER MARKER
7	Control A	1	0-12	
8	Control B	2	0-12	
5	Abnormal	3	0-28	
1	OFF	4	0-28	
	Standby	5		Not Used
3	Main	6	0-28	
12	28 VDC	7	28 \pm 5	
4	28 VDC	8	28 \pm 5	
D1TB1		E1TB-3		Middle Marker
7	Control A	1	0-12	
8	Control B	2	0-12	
5	Abnormal	3	0-28	
1	OFF	4	0-28	
	Standby	5		Not Used
3	Main	6	0-28	
12	28 VDC	7	28 \pm 5	
4	28 VDC	8	28 \pm 5	
D1TB1		E1TB4		Inner Marker
7	Control A	1	0-12	
8	Control B	2	0-12	
5	Abnormal	3	0-28	

TABLE III Continued

Wire From	Signal Name	Wire To	Operating Voltage (Volts)	Remarks
1	OFF	4	0-28	
	Standby	5		Not Used
3	Main	6	0-28	
12	28 VDC	7	28 <u>+5</u>	
4	28 VDC	8	28 <u>+5</u>	
B2A10TB1		E1TB5		Glideslope
15	Control A	1	0-12	
16	Control B	2	0-12	
12	Abnormal	3	0-28	
14	OFF	4	0-28	
10	Standby	5	0-28	
9	Main	6	0-28	
11	28 VDC	7	28 <u>+5</u>	
13	28 VDC	8	28 <u>+5</u>	
7	Intercom	9	-55 - +55	
8	Intercom	10	-55 - +55	
A2A10TB1		E1TB6		Localizer
15	Control A	1	0-12	
16	Control B	2	0-12	
12	Abnormal	3	0-28	
14	OFF	4	0-28	
10	Standby	5	0-28	
9	Main	6	0-28	
11	28 VDC	7	28 <u>+5</u>	

TABLE III (Continued)

Wire From	Signal Name	Wire To	Operating Voltage (Volts)	Remarks
13	28 VDC	8	28 <u>+5</u>	
7	Intercom	9	-55 - +55	
8	Intercom	10	-55 - +55	

WIRE INTERCONNECTION VIA TRANSIENT SUPPRESSOR BOX MARKER BEACON STATION

Wire From	Signal Name	Wire To	Operating Voltage (Volts)	Remarks
E1TB2-3-4		D1TB1		Outer-Middle- Inner
4	OFF	1	0-28	
6	Main	3	0-28	
8	28 VDC	4	28 <u>+5</u>	
3	Abnormal	5	0-28	
1	Control A	7	0-12	
2	Control B	8	0-12	
7	28 VDC	12	28 <u>+5</u>	

WIRE INTERCONNECTION VIA TRANSIENT SUPPRESSOR BOX GLIDESLOPE STATION

Wire From	Signal Name	Wire To	Operating Voltage (Volts)	Remarks
E1TB5		B2A10TB1		Remote Monitor Relay K1
6	Main	9	0-28	
5	Standby	10	0-28	Relay K2
7	28 VDC	11	28 <u>+5</u>	
3	Abnormal	12	0-28	Relay K4
8	28 VDC	13	28 <u>+5</u>	

TABLE III (Continued)

Wire From	Signal Name	Wire To	Operating Voltage (Volts)	Remarks
4	OFF	14	0-28	
1	Control	15	0-12	
2	Control	16	0-12	
9	Intercom	7	-55 - +55	
10	Intercom	8	-55 - +55	
MISALN DEY		1TB1		Equip Cabinet
E	MISALN	6	12	
F	MISALN	7	0-12	
NEARFIELD MON		1A35P1		
4A3TB1	28 VDC	1	28±5	

WIRE INTERCONNECTION VIA TRANSIENT SUPPRESSOR BOX LOCALIZER STATION

Wire From	Signal Name	Wire to	Operating Voltage (Volts)	Remarks
C1A16TB3		A2A10TB1		
8	DDM 2	2	+5.11	Far Field Mon
9	DDM Common	3	Floating	Far Field Mon
7	DDM 1	1	+5.11	Far Field Mon
5	Contact Common	6	28	
1	Contact A	4	0-36	
3	Contact B	5	0-36	
E1TB6				
9	Intercom	7	-55 -55	Remote Monitor
10	Intercom	8	-55 -55	Remote Monitor

TABLE III (Continued)

Wire From	Signal Name	Wire To	Operating Voltage (Volts)	Remarks
6	Main	9	0-28	Relay K1
5	Standby	10	0-28	Relay K2
3	Abnormal	12	0-28	Relay K4
7	+28 Volts	11	0-28	
8	+28 Volts	13	0-28	Relay K3
4	OFF	14	0-28	Relay K3
1	Control	15	0-12	
2	Control	16	0-12	

WIRING INTERCONNECTION VIA TRANSIENT SUPPRESSOR BOX FAR FIELD MONITOR

Wire From	Signal Name	Wire To	Operating Voltage (Volts)	Remarks
A2A10TB1		C1A15TB3		
4	Contact A	1	0-36	
5	Contact B	3	0-36	
6	Common	5	28 ± 5	
1	DDM 1	7	+5.11	
2	DDM 2	8	+5.11	
3	DDM COM	9	Floating	

spark gap.

V. LIGHTNING TRANSIENT PROTECTION FOR THE SSILS:

Since it was desired to fabricate, install, test, and demonstrate a transient suppression modification on an active system, actual circuit changes were kept to a minimum. Transient suppression circuits were fabricated on separate boards for "in line" installation between the utilities transition point and SSILS interface circuitry. Circuit design was based on suppressing a pulse having the characteristics presented in Figure 3 to a safe level. The protection would be required to handle not only a simple pulse but a burst of as many as forty pulses at a 100 Hz rate. Power line protection would be at the 2000-volt peak value since power is generally provided over long distances via overhead wires.

A. Data Line Protection

The basic circuit initially decided on was a hybrid, illustrated in Figure 5. Signalite CG-75 and CG-110 spark gaps were selected as the primary arrester devices. Since ionization of gas within these devices occurred in the order of approximately 64 and 85 volts respectively, additional circuitry was needed since these exceeded the rating of SSILS interface devices. General Semiconductor Industries series IN5555 (Military Specification MIL-S-19500/434, Reference 7) TransZorbs were selected as the secondary arrester. The IN5555 is a zener which has an extremely fast reaction time, in the order of 2-3 nanoseconds; therefore, the incoming transient is immediately clamped to a safe level for the equipment. Resistor R1 in Figure 5 provides a slight time delay and the impedance needed to permit voltage to continue rising across the spark gap after the zener clamps. Several microseconds after the transient pulse appears, the gas tube ionizes, providing a low impedance path to ground and

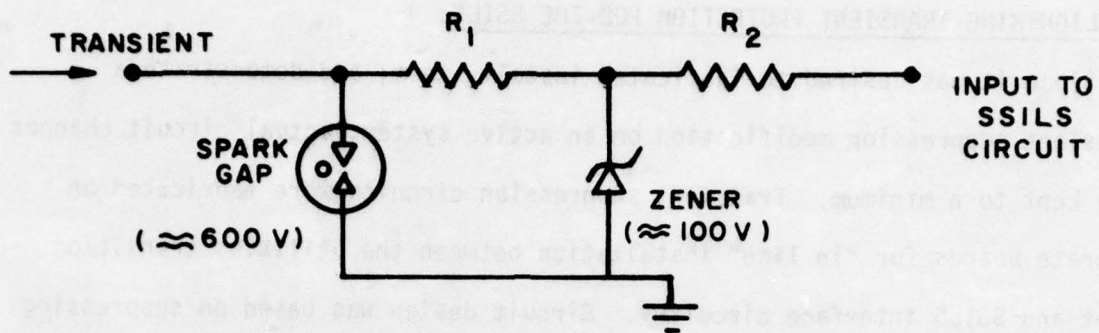

Figure 5 Basic Arrestor Circuit

protects the zener (transorb) from burnout. This current time relationship is illustrated in Figure 6. The R2 serves as a current limiter and impedance matching device to prevent short circuiting the interface components to ground while the spark gap is conducting.

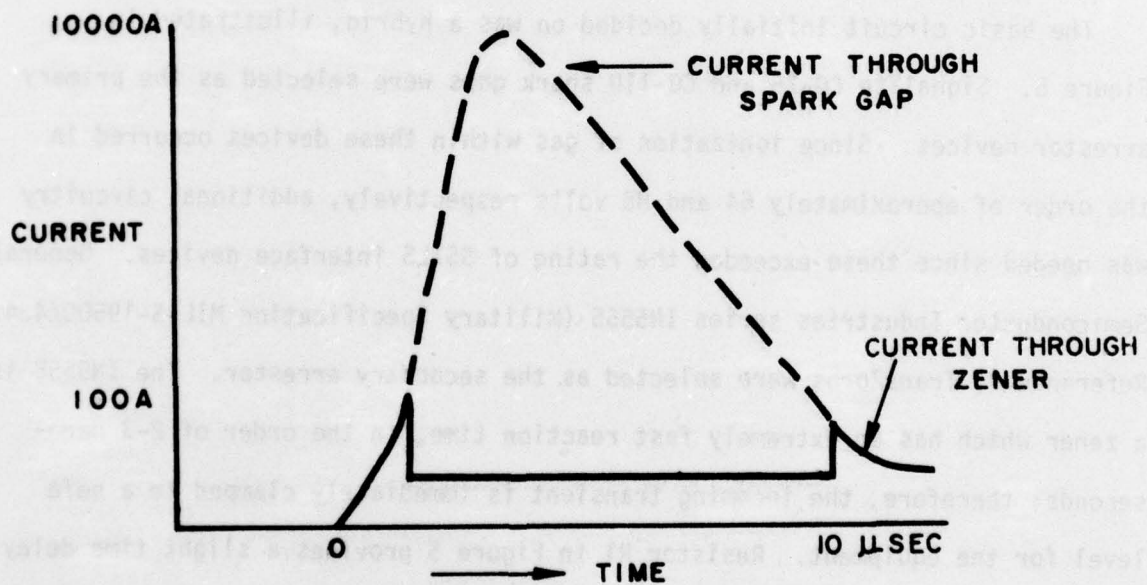

Figure 6 Current Through Protector Circuit

Each of the signal lines was individually analyzed, then parts selection was made to keep the number of different parts to a minimum and still provide adequate protection. It was determined that this protection could be provided

at two-line levels, 32 volts and 74 volts. A number of the data lines contained AC signals, thus needing bipolar devices. The Signalite CG-75 and CG-110 spark gaps met the requirement for bipolar operation for, respectively, the 32 and 74 volt lines. Transorbs L-39A and L-100A are back-to-back zeners of the IN5555 series encapsulated as a single part. The same basic circuit was repeated for each line, tailored as required. An overall module fabricated for each of the principal components of the SSILS is illustrated in Figures 7 through 11.

After initial testing, the basic circuit (Figure 5) was modified in two areas (Figure 12.) Resistor R3 was added as a current limiting device to enhance the longevity of the spark gap. Manufacturers' data sheets indicate a relatively short life for the spark gap, in the order of 40 strokes. Although tests indicated this figure to be conservative, the life expectancy was increased by a factor of at least 10 with the addition of the limiting resistor. A second significant change was made to the grounding buss. The ground side of the spark gap is immediately returned to the grounding stake at the utility pedestal, keeping the ground loop as short as possible to shunt the high transient potential away from sensitive circuitry. Other components are connected through chassis (system) ground to true ground providing the necessary isolation. This is illustrated in the schematic diagrams in Figures 13 and 14.

Physically, the protection circuits were wired onto printed circuit boards and placed in metal junction boxes. Photographs of the wired circuits for the Marker Beacon and Glideslope stations are shown in Figures 15 and 16. In each case the input cable was dressed into the bottom of the box and connected to the respective protection circuit along the left side. The ground sides of the

3

2

1

TRANSIENT PROTECTOR BOX

REVISIONS				
ZONE	LTR	DESCRIPTION	DATE	APPROVED
A		REVISED WITH EXTENSIVE CHANGES.		
B		VR1-VR3 CHANGED TO L-39A.		

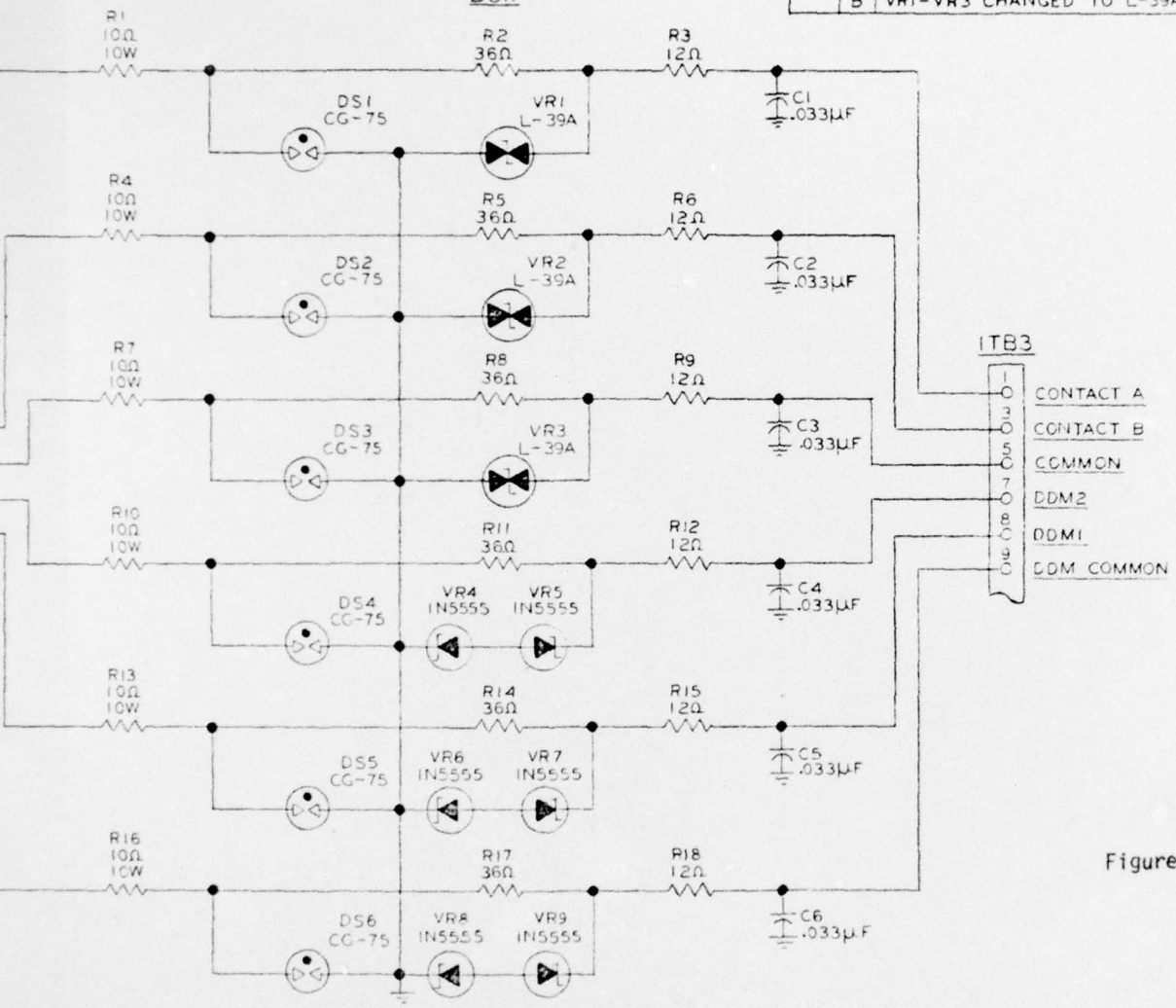

Figure 7

TRANSIENT SUPPRESSOR MODIFICATION

TYPE.
 LY TO INPUT SIDE OF CIRCUIT.
 CIRCUIT & BOND TO SYSTEM GROUND.

QTY	SYM	NUMERATURE	CODE IDENT	IDENTIFYING NO.	SPECIFICATION	MATERIAL	UNIT WT	ZONE	FIND NO
REQD									

UNLESS OTHERWISE SPECIFIED DIMENSIONS ARE IN INCHES		DRAFTSMAN	DATE
FRACTIONS	TOLERANCES ON DECIMALS	CHECKER	
+	.XX ±	ENGINEER	
-	.XXX ±	A.F. PROJ. ENGR	
MATERIAL		CONTRACT NUMBER	
		A.F. DESIGN ACTIVITY AUTHENTICATION	
		SIZE	A.F. CODE IDENT NO.
		C	07877
		SCALE	DRAWING NUMBER
			X7518629
			SHEET

U.S. AIR FORCE
 RADC
 TITLE
 SCHEMATIC DIAGRAM-
 MONITOR, RADIO FREQUENCY,
 MC-9026/GRN-27(V)
 SIZE
 C
 SCALE

ENGINEERING DRAWING LAYOUT C

2

3

2

MARKER BEACON STATIONS (INNER, MIDDLE, OUTER)

REVISION		DATE	APPROVED
ZONE	LTR	DESCRIPTION	
	A	REVISED WITH EXTENSIVE CHANGES.	
	B	VR1-VR7 CHANGED TO L-39A & NOS. ON DITBI CHANGED. *	2/2-51 [Signature]

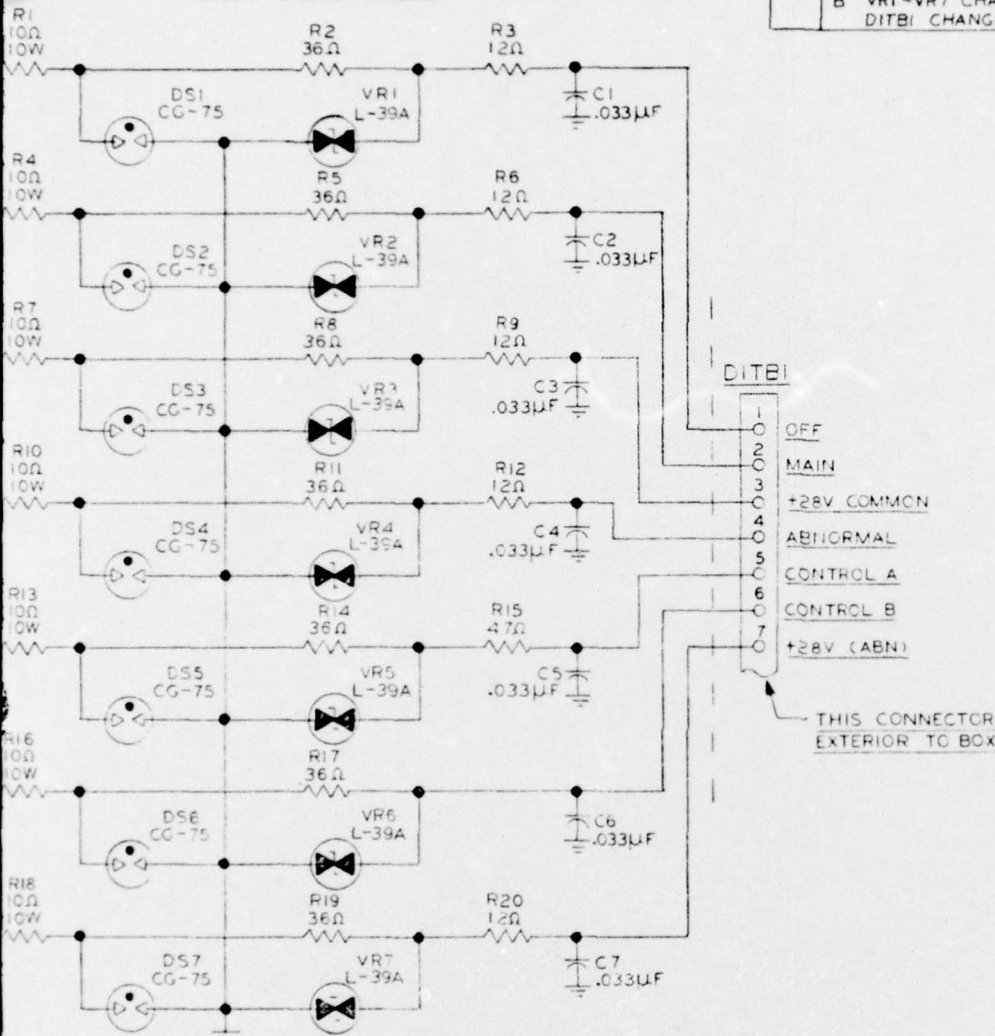

- DITBI
- 1 OFF
 - 2 MAIN
 - 3 +28V COMMON
 - 4 ABNORMAL
 - 5 CONTROL A
 - 6 CONTROL B
 - 7 +28V (ABN)

THIS CONNECTOR EXTERIOR TO BOX

Figure 8

TRANSIENT SUPPRESSOR MODIFICATION

INPUT SIDE OF CIRCUIT.
IT & BOND TO GROUND.

QTY	SYM	NOMENCLATURE	CODE IDENT	IDENTIFYING NO	SPECIFICATION	MATERIAL	UNIT WT	ZONE	FIND NO
-----	-----	--------------	------------	----------------	---------------	----------	---------	------	---------

LIST OF MATERIALS

UNLESS OTHERWISE SPECIFIED DIMENSIONS ARE IN INCHES		
FRACTIONS TOLERANCES OR DECIMALS OR ANGLES		
± .XX ±		
± .XXX ±		
MATERIAL		
75186ZF		
NEXT ASSY	USED ON	NEXT ASSY / FINAL ASSY
APPLICATION	QTY REQD	

DRAFTSMAN	DATE
CHECKER	
ENGINEER	
A.F. PROJ. ENGR	
CONTRACT NUMBER	
A.F. DESIGN ACTIVITY AUTHENTICATION	

U.S. AIR FORCE RADC		
TITLE SCHEMATIC DIAGRAM - BEACON SET, RADIO, AN/GRN-26		
SIZE C	A.F. CODE IDENT NO 07877	DRAWING NUMBER X7518630
SCALE		SHEET 19

ENGINEERING DRAWING LAYOUT C

U.S. GOVERNMENT PRINTING OFFICE: 1963 O-700-074

2

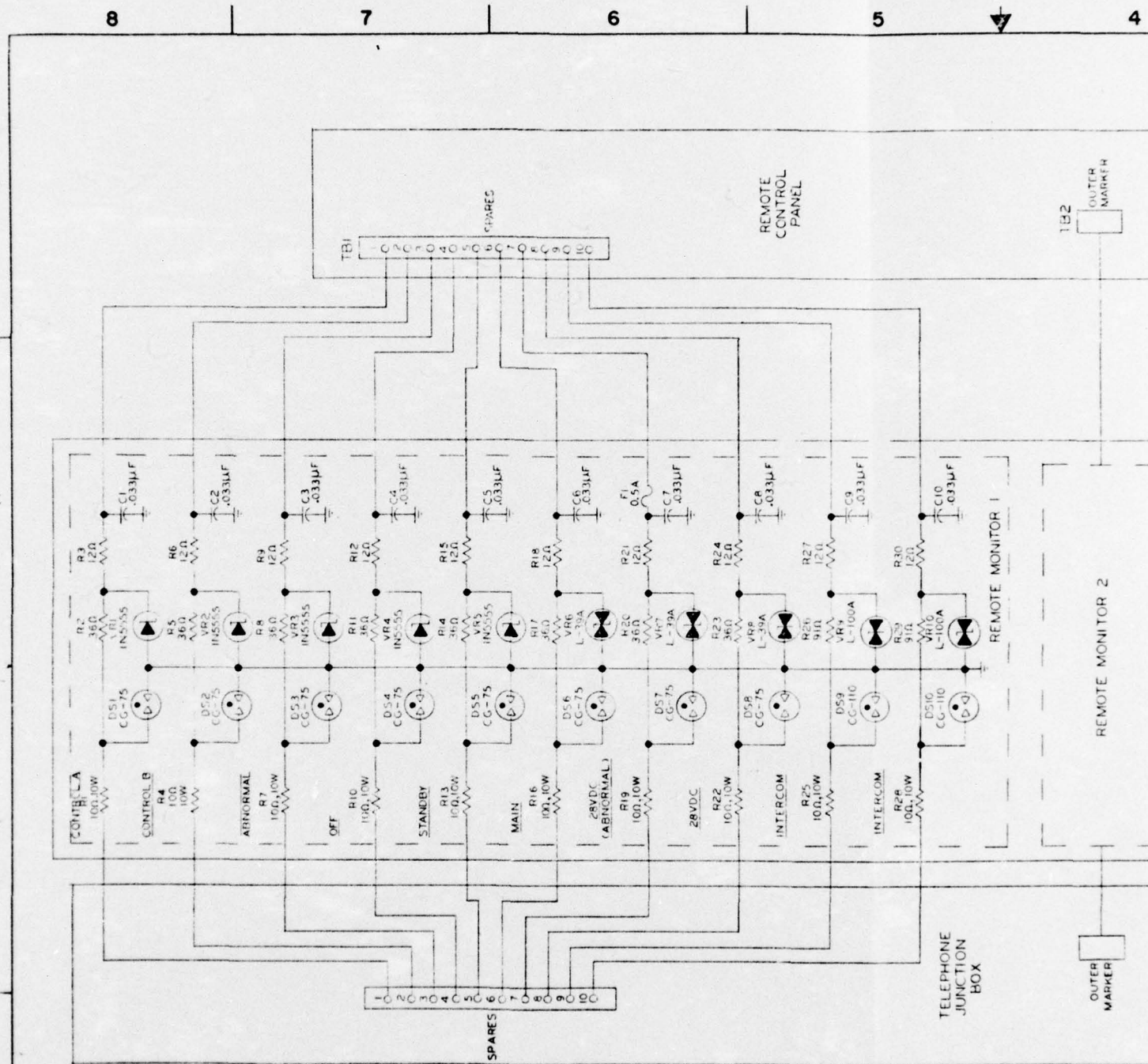

NOTES:

1. REMOTE MONITOR 2-6 IDENTICAL TO REMOTE MONITOR 1. REPEAT CIRCUIT AS REQUIRED.
2. ALL RESISTORS ARE 1 WATT EXCEPT AS NOTED.
3. WIRING FOR INTERCOM NOT REQUIRED FOR OTHER THAN LOCALIZER AND GILESLOPE.
4. F1 FUSE IS A FASTBLOW.
5. ZENER DIODES VR9-10 ±90V. ALL OTHERS CLAMP AT 33V TO 47V.
6. PRESS GROUND FROM SPARK GAPS SEPARATELY TO INPUT SIDE OF CIRCUIT. PRESS ALL OTHERS ALONG OUTPUT SIDE & BOND TO SYSTEM GROUND.
7. VR9-10 ARE BIPOLAR SILICONE DIODES. CLAMP LEVEL 90V. SEMTECH DESIGNATION L-100A.
8. 10W RESISTORS SHOULD BE NONINDUCTIVE TYPE.

Figure 9

5 4 3 2 1

REVISIONS				
ZONE	LTR	DESCRIPTION	DATE	APPROVED
	A	REVISED WITH EXTENSIVE CHANGES		
	B	VRE-VRE CHANGED TO L-39A & NINE RESISTORS ADDED		

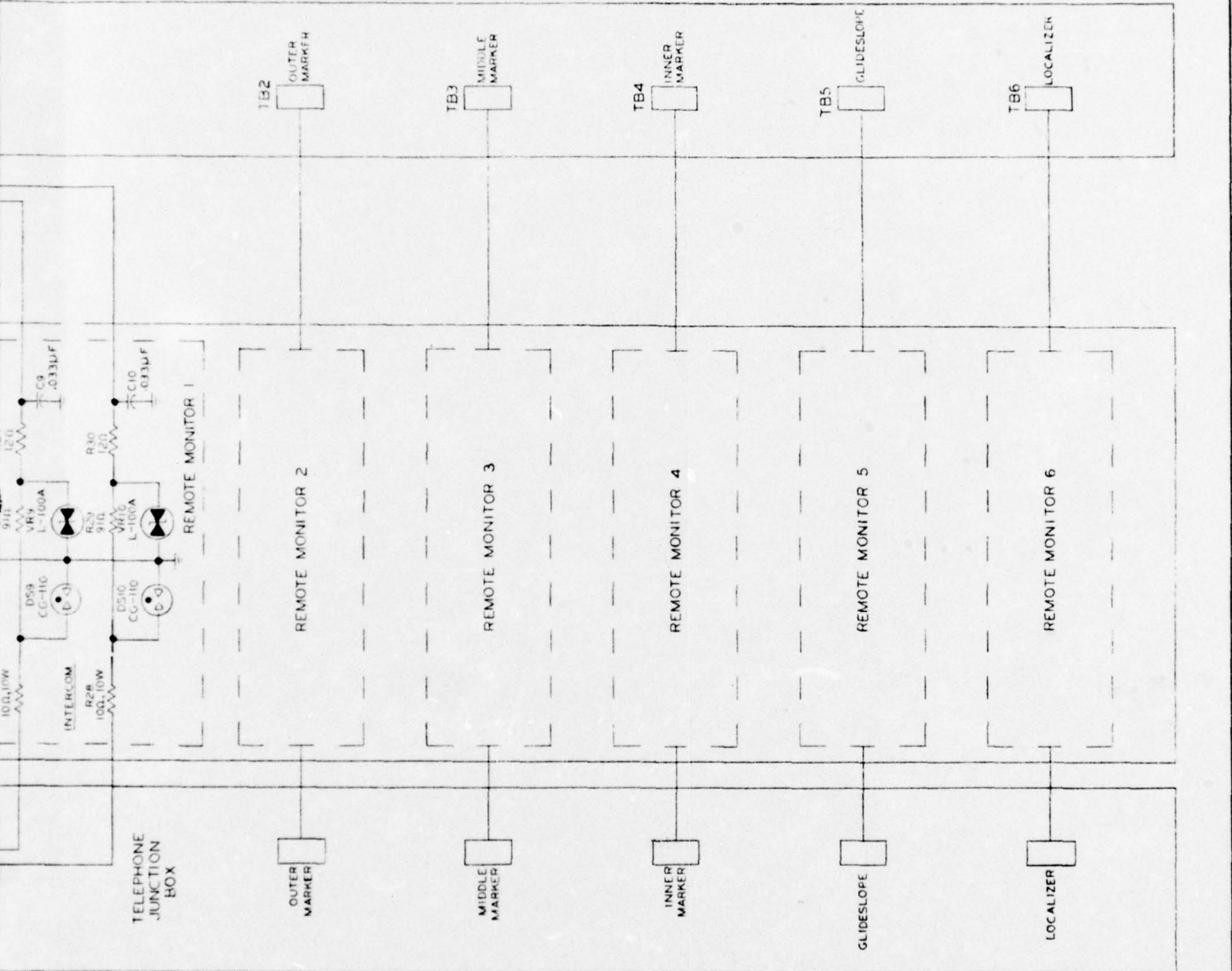

TRANSIENT SUPPRESSOR MODIFICATION

QTY	DESCRIPTION	CODE	IDENT	IDENTIFYING NO.	OPERATION	MATERIAL	UNIT	WT	QTY	REQD

QTY	DESCRIPTION	CODE	IDENT	IDENTIFYING NO.	OPERATION	MATERIAL	UNIT	WT	QTY	REQD

UNLESS OTHERWISE SPECIFIED DIMENSIONS ARE IN INCHES TOLERANCES ON FINISHES .005 .010 .015 .020 .030 .040 .050 .060 .070 .080 .090 .100 .125 .150 .175 .200 .250 .300 .375 .450 .500 .625 .750 .875 1.000 1.250 1.500 1.750 2.000 2.500 3.000 3.500 4.000 4.500 5.000 5.500 6.000 6.500 7.000 7.500 8.000 8.500 9.000 9.500 10.000		DATE DESIGNED CHECKED A.P. POUL SEN CONTRACT NUMBER A.F. DESIGN ACTIVITY AUTHORIZATION DATE 07877 SCALE 1:1	TITLE SCHEMATIC DIAGRAM- CONTROL-INDICATOR. C-8826/GRN-27(V) U.S. AIR FORCE RADC DRAWING NUMBER X7518631
---	--	--	---

Figure 9

2

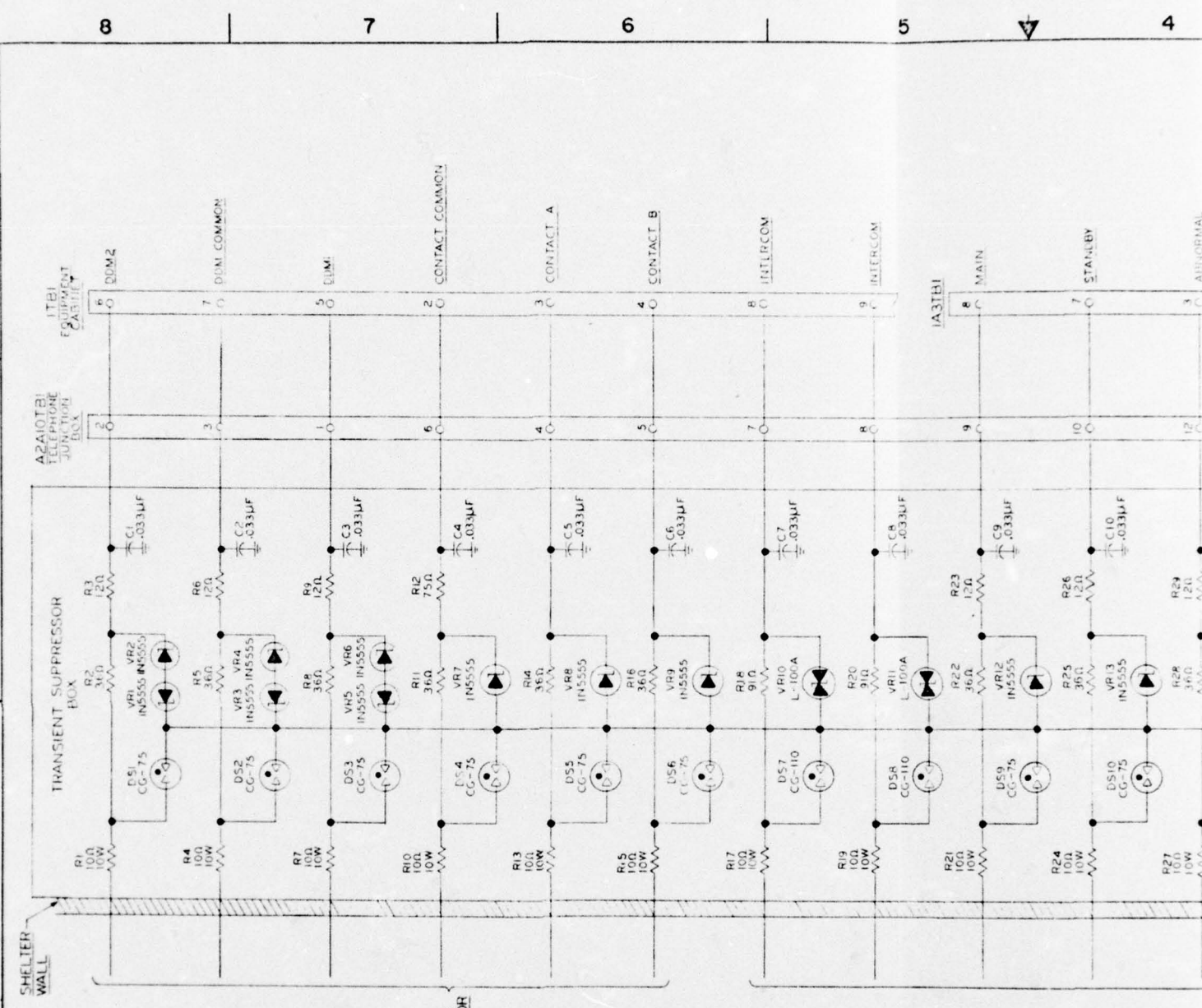

NOTES:

- 1 ALL RESISTORS ARE 1 WATTS EXCEPT AS NOTED.
- 2 DRESS ALL GROUNDS FROM SPARK GAPS SEPARATELY ALONG INPUT SIDE OF ASSEMBLY.
DRESS ALL OTHERS ALONG OUTPUT SIDE & BOND TO SYSTEM GROUND.
- 3 DRESS 3 WIRES FOR DDM CONTROL AWAY FROM OTHER CIRCUITS.
- 4 CG-75 AND CG-110 ARE SIGNALITE DESIGNATIONS FOR TRANSIENT PROTECTOR DEVICES.
- 5 CABLE ENTERING LOCALIZER SHELTER SHOULD FEED DIRECTLY INTO TRANSIENT SUPPRESSOR BOX OR WITHIN METAL CONDUIT.
- 6 VR10-11 ARE BIPOLAR SILICONE DIODES, CLAMP LEVEL 90V. SEMTECH DESIGNATION L-10CA.
- 7 10W RESISTORS SHOULD BE NONINDUCTIVE TYPE.

Figure 10

5 4 3 2 1

REVISIONS			
ZONE	LTR	DESCRIPTION	DATE
A		REVISED WITH EXTENSIVE CHANGES	
B		RESISTOR ADDED	

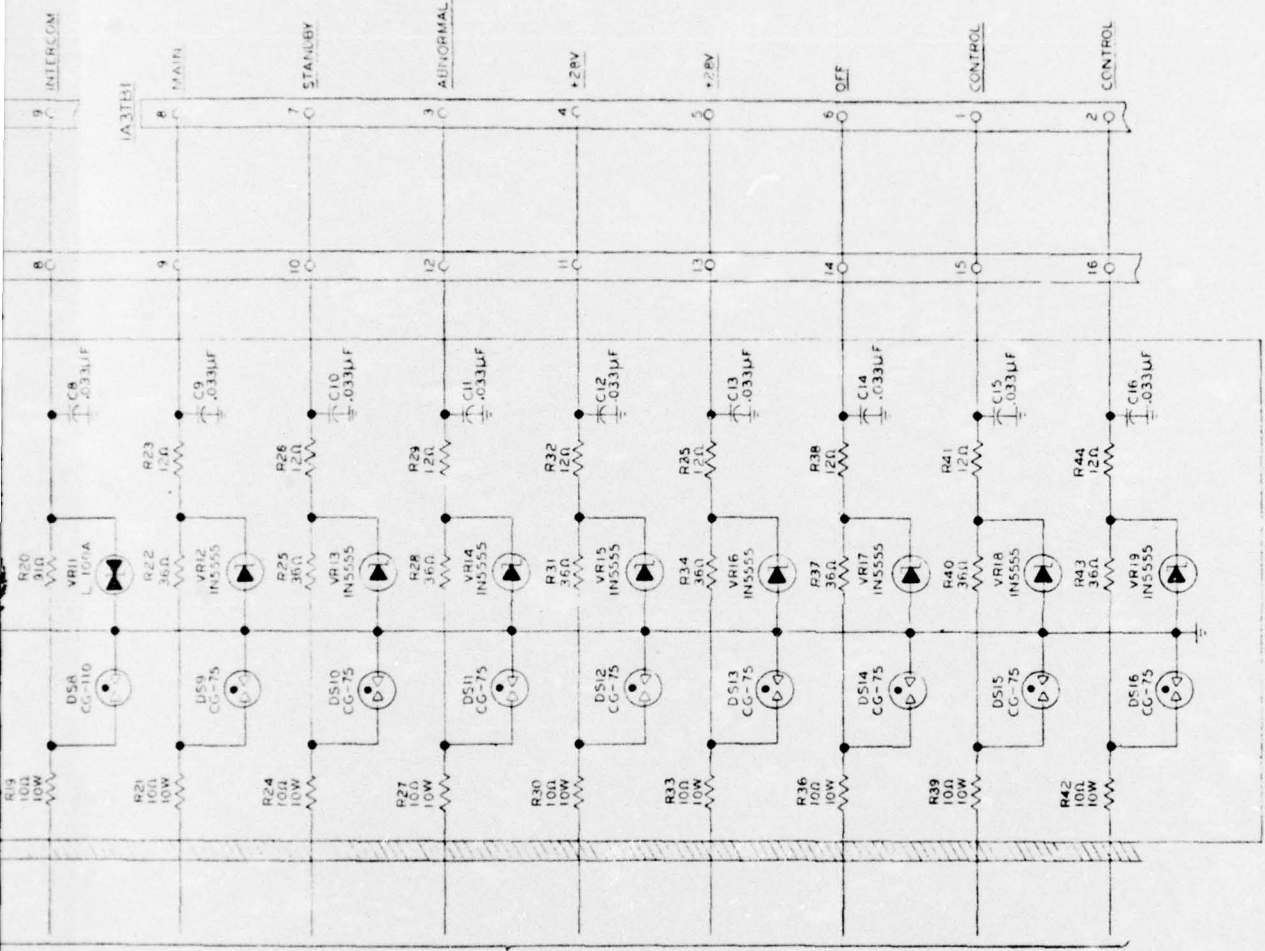

TO
REMOTE
CONTROL
MONITOR
E1TB6

TRANSIENT SUPPRESSOR MODIFICATION

QTY	SYM	DESCRIPTION	QTY REQD	IDENTIFYING NO.	SPECIFICATION	MATERIAL	UNIT	QTY	QTY REQD	QTY REQD																																
LIST OF MATERIALS																																										
UNLESS OTHERWISE SPECIFIED DIMENSIONS ARE IN INCHES																																										
FRONTIER TOLERANCES ON SIGNALS																																										
.10 ±																																										
.05 ±																																										
.02 ±																																										
APPROVAL																																										
<table border="1" style="width: 100%;"> <tr> <td colspan="2">DESIGNER</td> <td colspan="2">DATE</td> </tr> <tr> <td colspan="2">DRAWN</td> <td colspan="2">TITLE</td> </tr> <tr> <td colspan="2">A.P. PROJ. CONT.</td> <td colspan="2">U.S. AIR FORCE RADG</td> </tr> <tr> <td colspan="2">CONTRACT NUMBER</td> <td colspan="2">SCHEMATIC DIAGRAM- LOCALIZER STATION, AN/GRN-27(V)</td> </tr> <tr> <td colspan="2">A.P. USER ACTIVITY AUTHORIZATION</td> <td>QTY</td> <td>A.P. QTY</td> </tr> <tr> <td colspan="2"></td> <td>D</td> <td>07877</td> </tr> <tr> <td colspan="2"></td> <td>QTY</td> <td>751E632</td> </tr> <tr> <td colspan="2"></td> <td>QTY</td> <td>21</td> </tr> </table>											DESIGNER		DATE		DRAWN		TITLE		A.P. PROJ. CONT.		U.S. AIR FORCE RADG		CONTRACT NUMBER		SCHEMATIC DIAGRAM- LOCALIZER STATION, AN/GRN-27(V)		A.P. USER ACTIVITY AUTHORIZATION		QTY	A.P. QTY			D	07877			QTY	751E632			QTY	21
DESIGNER		DATE																																								
DRAWN		TITLE																																								
A.P. PROJ. CONT.		U.S. AIR FORCE RADG																																								
CONTRACT NUMBER		SCHEMATIC DIAGRAM- LOCALIZER STATION, AN/GRN-27(V)																																								
A.P. USER ACTIVITY AUTHORIZATION		QTY	A.P. QTY																																							
		D	07877																																							
		QTY	751E632																																							
		QTY	21																																							
APPLICATION QTY REQD																																										

Figure 10

ENGINEERING DRAWING LAYOUT D

2

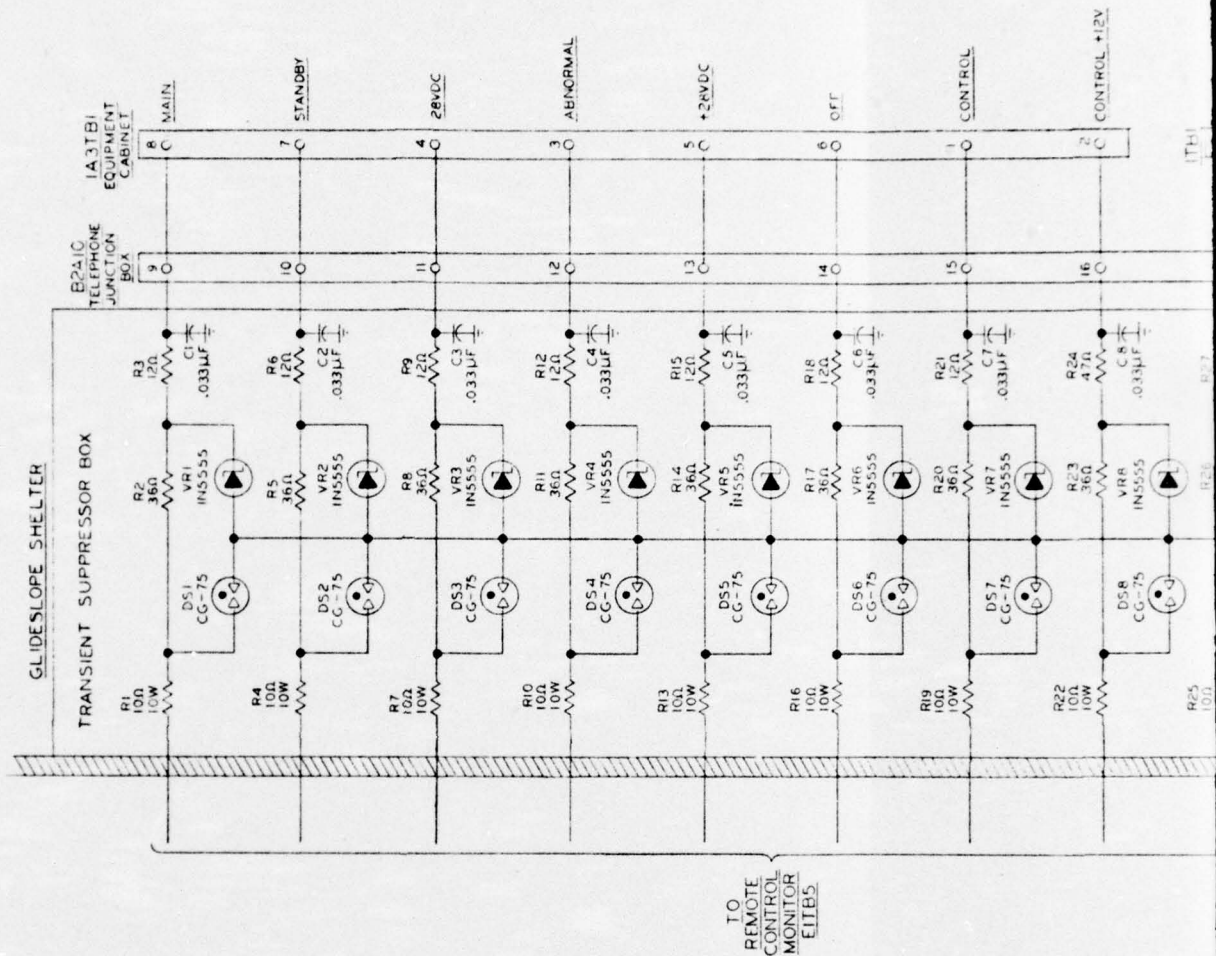
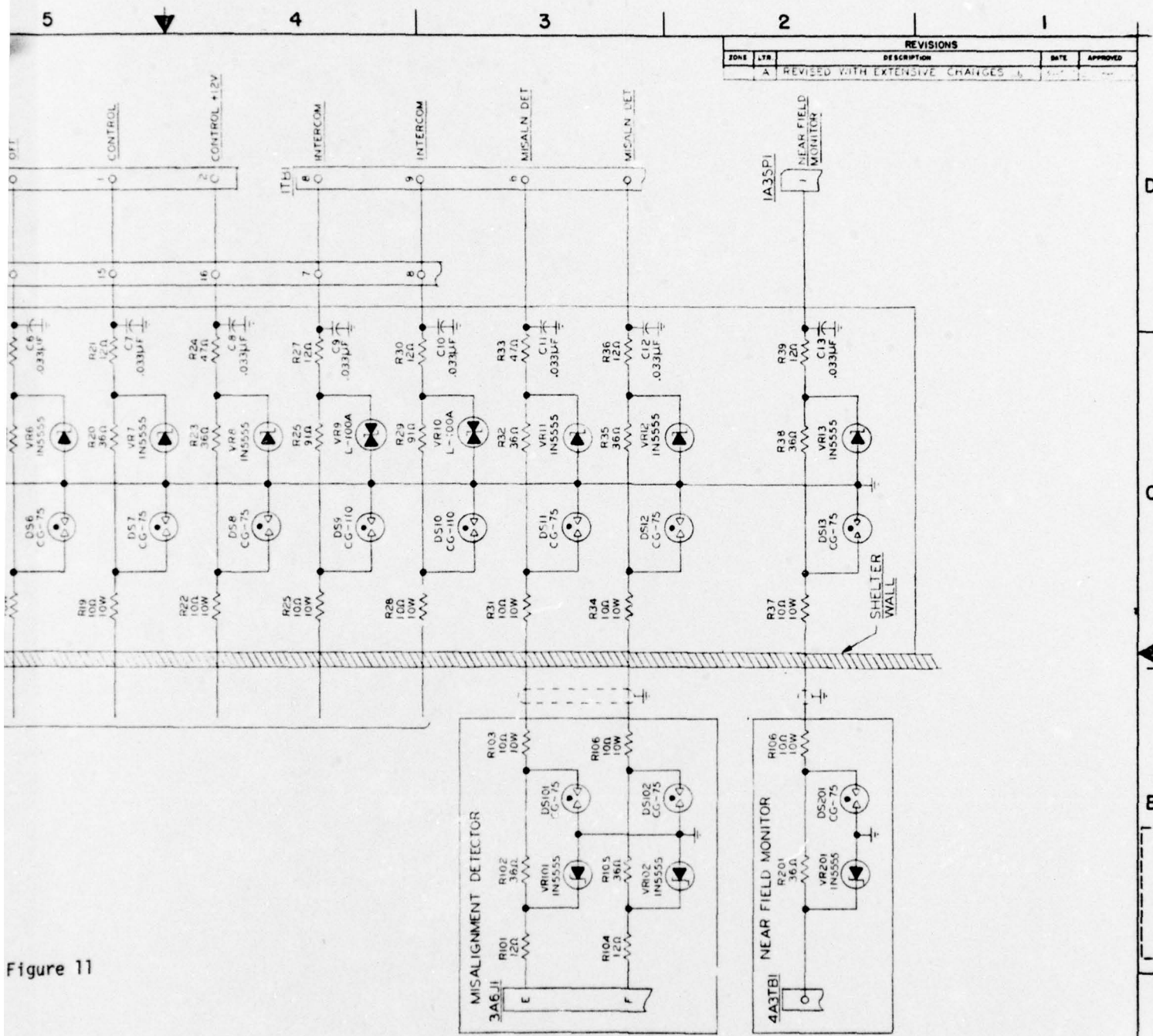

Figure 11

- 1- ALL RESISTORS 1 WATTS EXCEPT AS NOTED.
- 2- DRESS ALL GROUNDS FROM SPARK GAPS SEPARATELY ALONG INPUT SIDE OF ASSEMBLY. DRESS ALL OTHERS ALONG OUTPUT SIDE & BOND TO SYSTEM GROUND.
- 3- CG-75 AND CG-110 ARE SIGNALITE DESIGNATIONS FOR TRANSIENT PROTECTOR DEVICES.
- 4- CABLES ENTERING THE GLIDESLOPE SHELTER OR ANCILLARY COMPONENTS SHOULD FEED DIRECTLY INTO THE TRANSIENT SUPPRESSOR BOX OR BE WITHIN A METAL CONDUIT.
- 5- VR9 AND VR10 ARE BIPOLAR SILICONE DIODES, CLAMP LEVEL 90V. SEMTECH DESIGNATION L-100A.
- 6- 10W RESISTORS SHOULD BE NONINDUCTIVE TYPE.



REVISIONS			
ZONE	LTB	DESCRIPTION	DATE
A		REVISED WITH EXTENSIVE CHANGES	

Figure 11

TRANSIENT SUPPRESSOR MODIFICATION

REV	DATE	DESCRIPTION	BY	CHKD

LIST OF MATERIALS		QUANTITY	UNIT

U.S. AIR FORCE RADC	
TITLE SCHEMATIC DIAGRAM - GLIDESLOPE STATION AN/GRN-27(V)	
A.F. ORDER ACTIVITY AUTHORIZATION	SCALE
D	07877
	X751e633

ENGINEERING DRAWING LAYOUT D

2

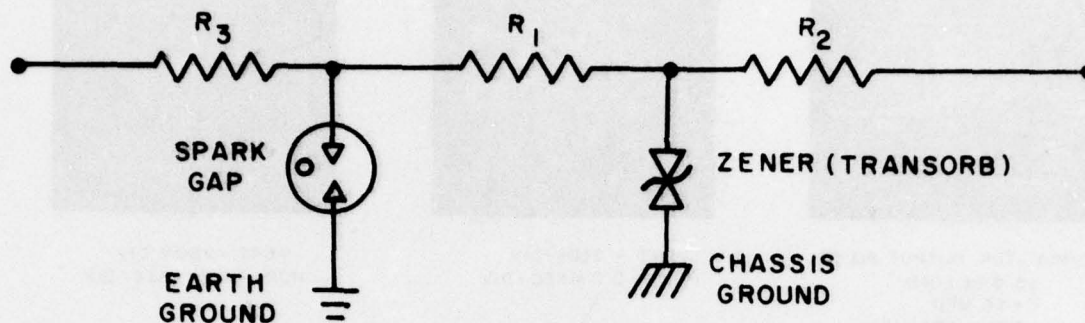
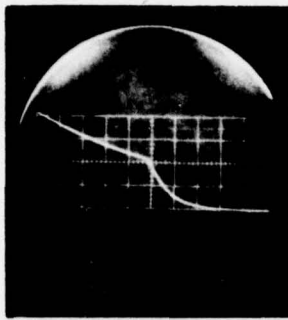

Figure 12, Modified Arrestor Circuit

spark gaps were connected to a large ground buss which was returned to the grounding stake at the utilities' pedestal. Filtered signals appeared on the right side of the circuit boards. These were routed, via shielded wires, away from the input cables, to the appropriate circuits of the SSILS.

The circuits discussed were the principal line of protection placed directly onto the signal lines of the SSILS. Various other modifications were incorporated into the existing circuitry of the instrument landing system to enhance protection or the possibility of false indications which may be attributed to transients. These included diode shunts, hold-off circuits and time delays. The little independent circuit board appearing at the bottom of Figure 16, for example contains a time delay circuit used in resetting the glideslope monitors from the remote monitor position.



SIMULATOR OUTPUT PULSE
 25 OHM LOAD
 C = 56 MFD
 VERT - 250 V/DIV
 HOR - 0.2 m SEC/DIV

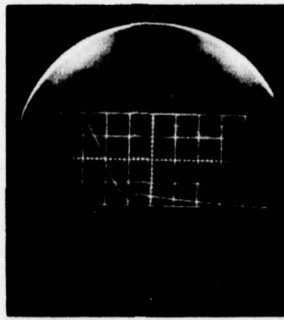

VERT - 250V/DIV
 HOR - 0.2 mSEC/DIV



VERT - 250V/DIV
 HOR - 0.2 m SEC/DIV

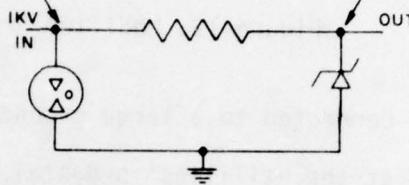
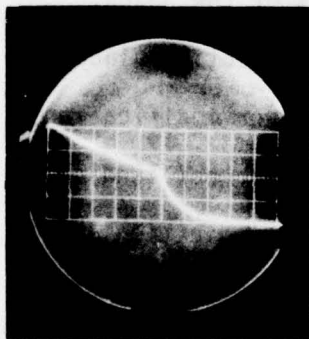
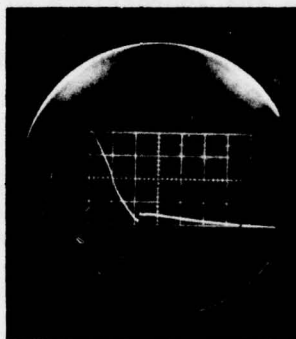

Figure 13 Transient Effects Using Common Ground



SIMULATOR OUTPUT PULSE
 25 OHM LOAD
 C = 56 UFD
 VERT - 250 V/DIV
 HOR - 0.2 m SEC/DIV



VERT - 100V/DIV
 HOR - .2 mSEC/DIV

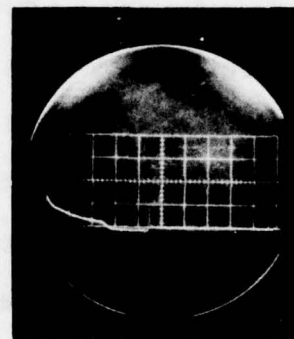

VERT - 100V/DIV
 HOR - .2 mSEC/DIV

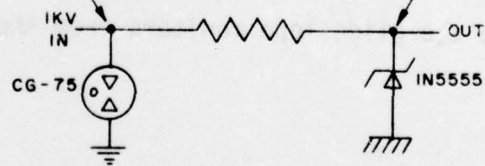

Figure 14 Transient Effects Using Separate Grounds

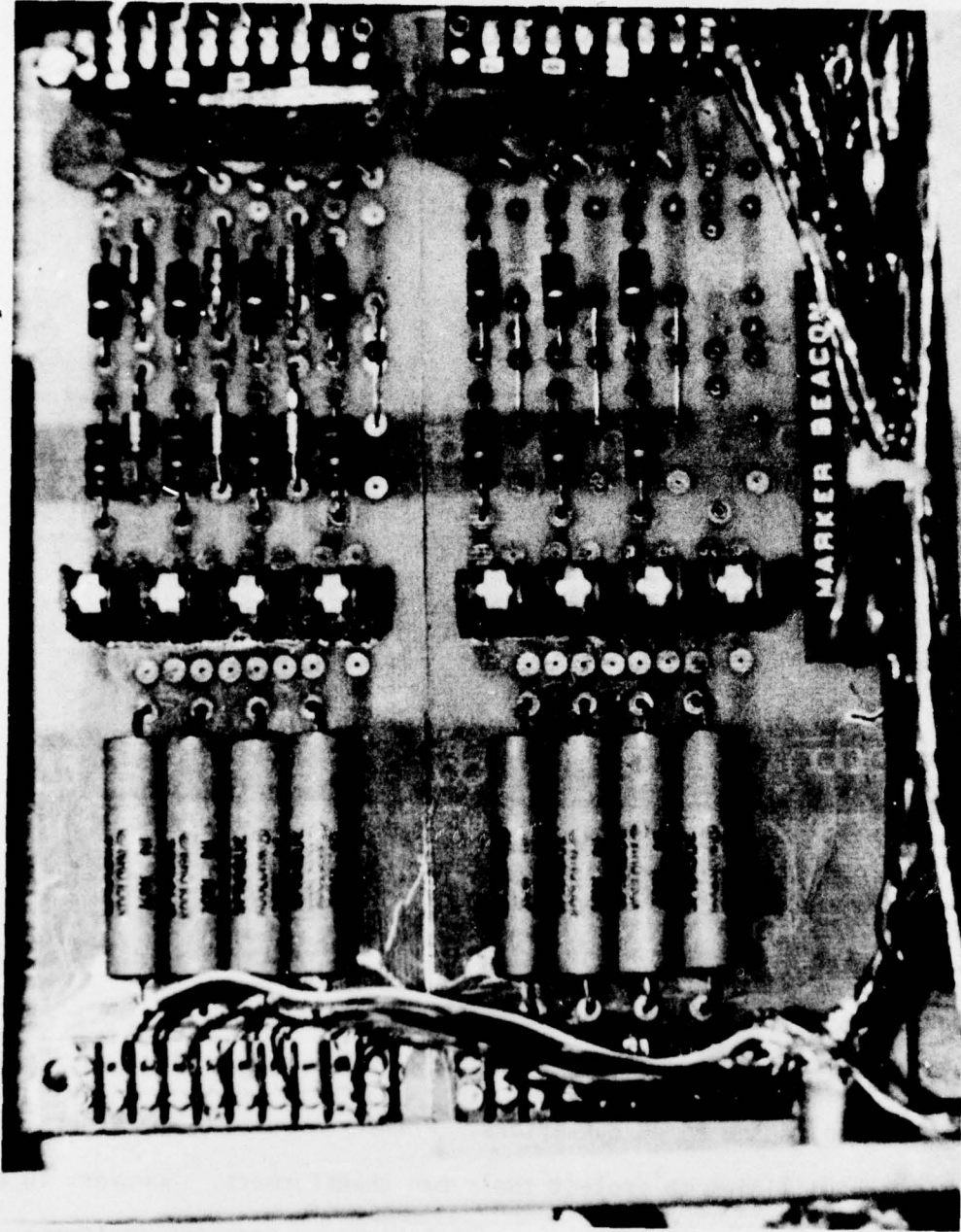

Figure 15 Wired Circuit, Transient Protection for Marker Beacon

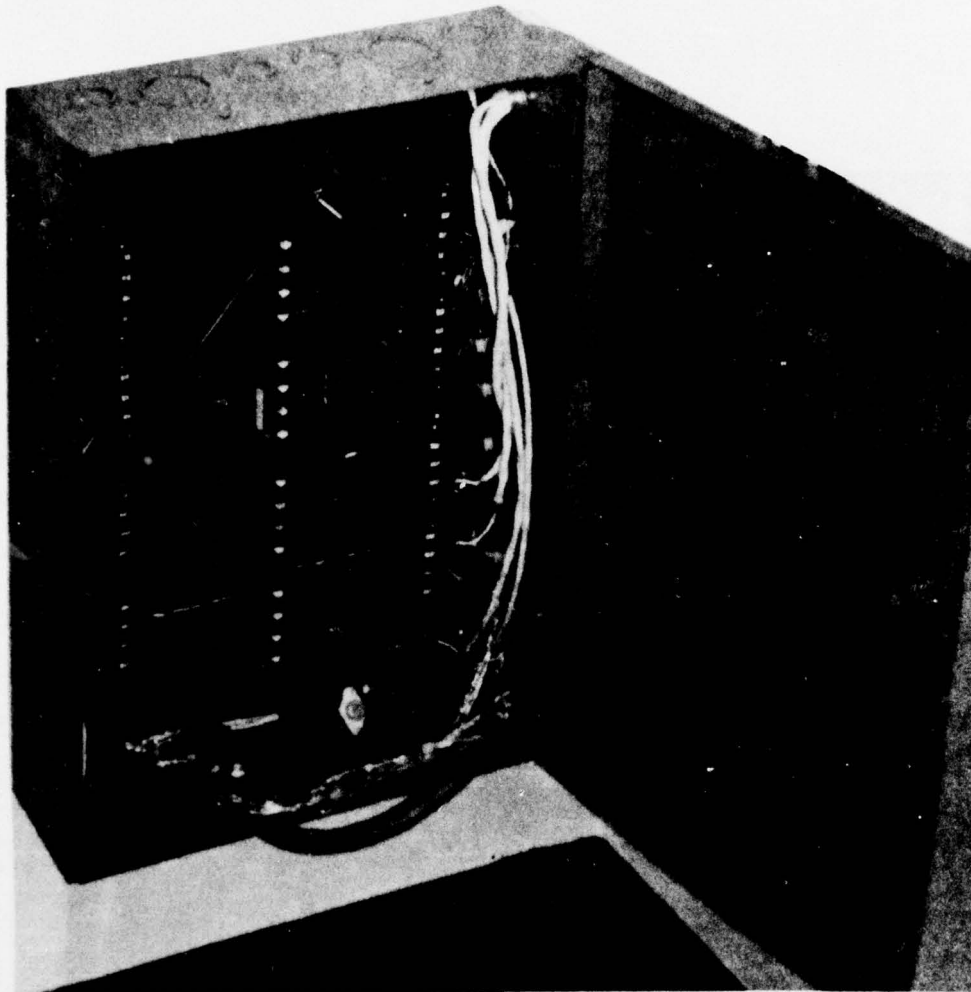

Figure 16 Wired Circuit, Transient
Protection for Glideslope

B. Power Line Protection

Although the input power lines are technically isolated from the critical SSILS circuits, through the battery bank and battery charger, failures were being experienced in the DC/DC convertors. Primary arrestors are generally provided by the utilities to protect their own transformers. However, in an ILS installation this may be at a substantial distance from the equipment shelter. It was considered advisable to place secondary arrestors at the localizer, glideslope, and marker beacon stations. The far field monitor,

co-located with the middle marker beacon, was protected by a common unit. The arrester modification used in the localizer and glideslope stations is shown in schematic form in Figure 17. The Joslyn Type #1235-01 was selected for these stations. Joslyn Protector Type #1230-01 was used at the marker beacon stations. Since these are sealed hybrid units, neon lights were employed on each power buss to indicate an operational protector. When the protector shorts to ground, which is the normal failure mode, the light is extinguished, indicating the failure. A photograph of the installed circuit at the Glideslope Station is shown in Figure 18.

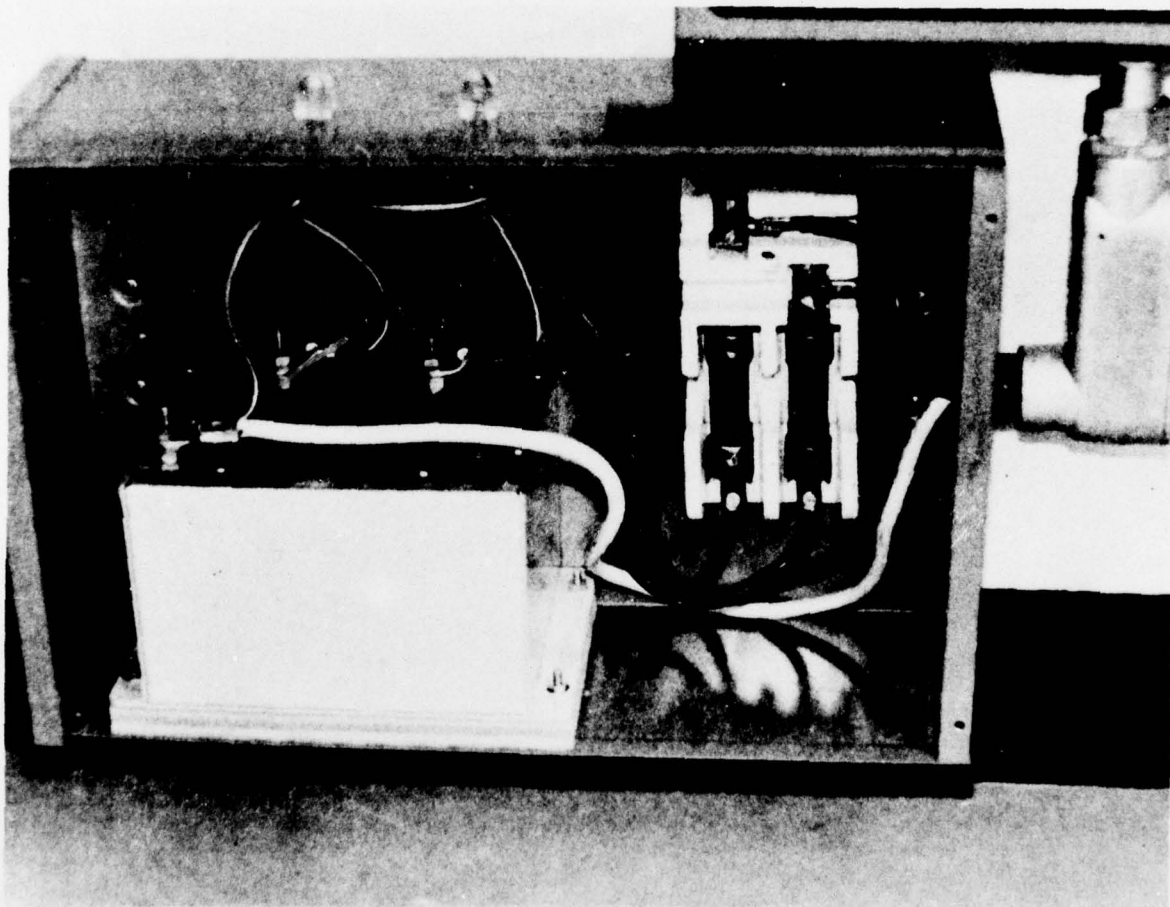

Figure 18 Prime Power Line Protection Circuit,
Glideslope and Localizer Stations

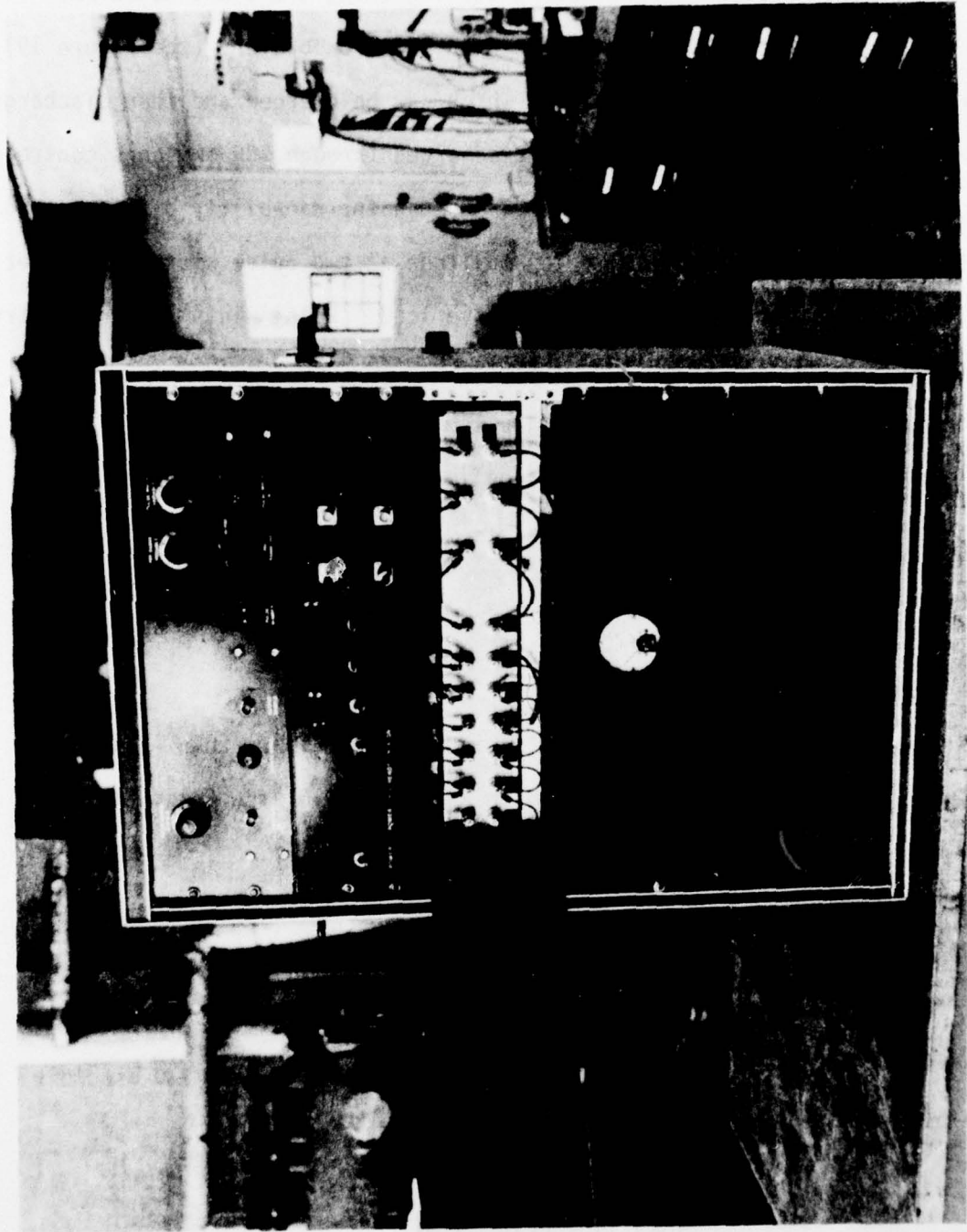

Figure 19 Lightning Simulator

VI. LIGHTNING SIMULATOR:

A simulator capable of reproducing the lightning transient pulse was designed and fabricated within the RADC High Power Laboratory (see Figure 19). It contains a bank of pulse capacitors which can be charged and then discharged on demand. The selected wave form is discharged through SCR switches controlled by associated logic circuits. The simulator has the capability of generating 1 to 100 pulses, 100 to 1000 volts in amplitude at two pulse widths, 100 μ sec and 1 msec across a nominal 25 ohm resistive load. Pulse width and energy are determined by capacitor selection, i.e.

1. 100 msec pulse 8 MFD 1KV = 4j/pulse

2. 1 msec pulse 58 MFD 1KV = 29j/pulse

$$\begin{aligned} E &= 1/2 CV^2 \\ &= 1/2 (58 \text{ MFD}) (10^3)^2 \\ &= 1/2 (58) \\ &= 29 \text{ joules/pulse} \end{aligned}$$

A typical photograph of the output pulse is shown in Figure 20. Additional details on the simulator are published in RADC-TM-76-10 "The Solid State Lightning Simulator" by Joseph J. Polniaszek.

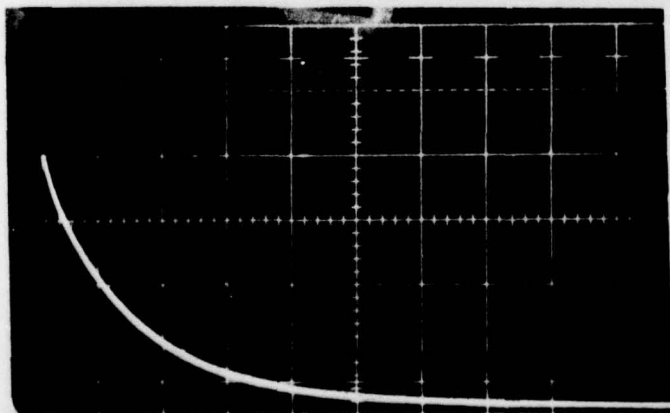

Vertical - 200V/Div
Horizontal - 1.0 msec/Div

Figure 20 Output Pulse From Lightning Simulator (25 ohm load)

VII. FIELD TESTING:

Field testing was conducted in two phases: Phase I, a simulated test on a "hot-mock-up" and Phase II, implementation of an active operational AN/GRN-27(v) system. Details of these tests are documented in the "Final Test Report, AN/GRN-27(v) SSILS Lightning Fix Project" published by Electronics Systems Division (ESD), which was prepared by the AFSC/AFCS Test Team. In each phase of testing, design personnel implemented the protection modification and conducted a preliminary test to verify that the modification functioned properly and system operation was not being degraded. A Test Team consisting of AFSC-ESD and AFCS personnel then conducted an intense acceptance test.

The basic test setup is shown in Figure 21. Both ends of each data line under test were monitored while the transient was superimposed on the line. This test pulse was inserted at the connecting point for SSILS equipment and the telephone line at both ends of each line that was tested. Test pulses were started at 100 volts and graduated in 100-volt increments to peak voltage of 1000 volts. Each line was pulsed a minimum of six times with a single pulse followed by a burst of 40 pulses. Figure 22 shows the advancement of the pulse in amplitude. The reproducibility of the waveform is particularly worthy of notice since it is relatively constant even in the burst mode.

It was during the Phase I testing period that circuit refinements were derived for direct application to the AN/GRN-27. It was also during this period that the change was made to the basic circuit from that shown in Figure 5 to that of Figure 12. Sufficient confidence was gained that the protection circuits were adequate to protect the SSILS circuitry from harmful transients reaching an amplitude of 1000 volts peak. With this confidence, the refurbished, refined protection circuits were installed on the operational

AN/GRN-27(v) at McGuire AFB, New Jersey. The same sequence of tests was again performed first by the designers, then the impartial AFSC/AFCS Test Team. After three months of testing by the Test Team and exposure to the natural environment, the modification was deemed acceptable to the User.

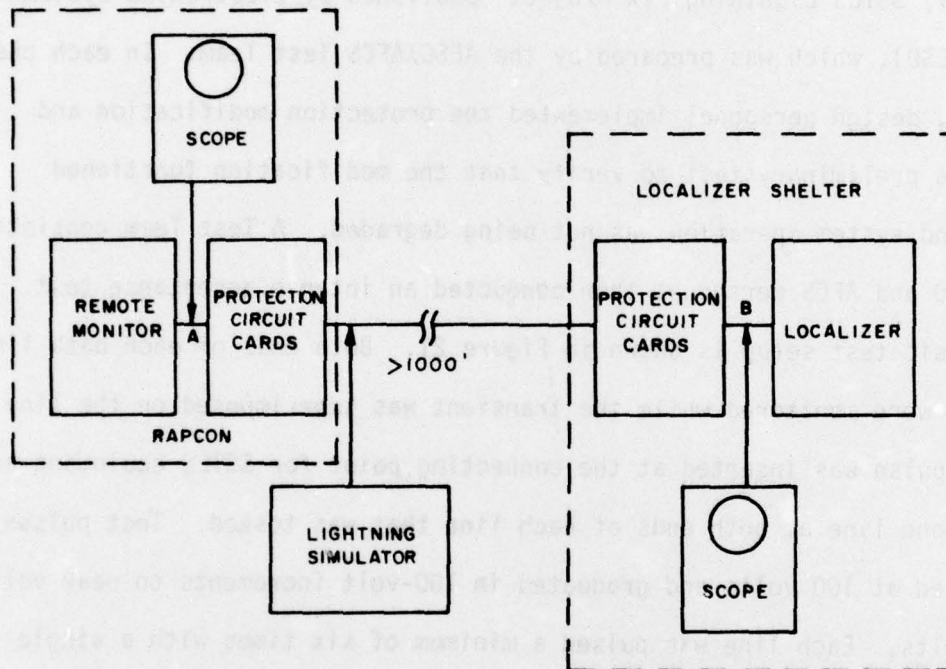
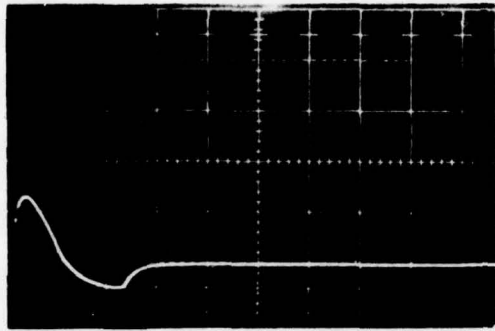

Figure 21 Typical Test Set-up At Operational Facility - Lightning Transient Test

VIII. CONCLUSIONS AND RECOMMENDATIONS:

It was found that documentation of data and experiences relating to the characteristics of transients generated by lightning is not readily available. Since detailed data was lacking and time and funding were not adequate for an in-depth monitoring and data collection study, a number of assumptions were made relative to the transient characteristics. It may be derived that at least some of these assumptions were made correctly since the AN/GRN-27 at McGuire AFB is presently sustaining its second season of successful operation with the transient protection modification. Lightning is one of the oldest



200 v

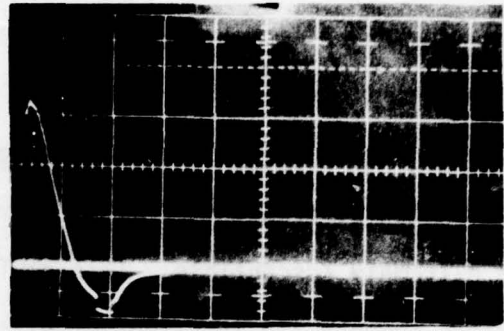

700 v

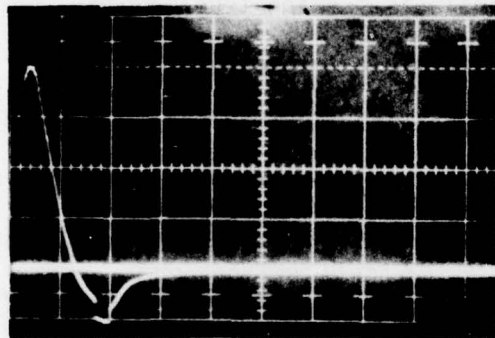

1000 v

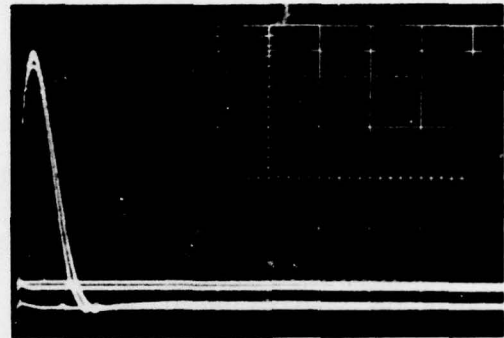

40 Pulse Burst

Figure 22 Test Pulse Sequence Lightning Transient Test
Vertical - 20v/Div
Horizontal - 0.1 milsec/Div

phenomena known to man. We have some relative knowledge of the potential energy it may contain, but know very little about the characteristics and side effects of this energy. Whereas tube type devices are relatively nonresponsive to transients, transistors and integrated circuits by nature of their design are extremely susceptible. This could be catastrophic, particularly when these devices compose the input/output circuits of equipment like the instrument landing system. The many antennas and interconnecting cables are virtual collectors and transmission lines for transients seeking true ground.

Transient protection for equipment which may be exposed to such an environment should become a design requirement for Air Force and DOD equipment. Judicious selection of parts will help to protect the inner circuit which may have susceptibility even with interface protection. A number of good devices suitable for protection are becoming available and may be applied directly to the operational circuits.

It is recommended that a program be initiated by the Air Force to:

- A. Study the characteristics of lightning.
- B. Develop a good set of characteristics applicable for various types of systems.
- C. Establish a standard, such as MIL-STD-461 and MIL-STD-462, outlining the withstand requirements and proven, acceptable methods of testing for compliance.
- D. Evaluate and recommend approval or limitations of protection devices.
- E. Evaluate and certify test equipment.

REFERENCES

1. Worldwide Airfield Climate Data, USAF Environmental Technical Applications Center, Vol. VIII parts 6 & 7
2. Douglass, D. A., Bell Laboratories "Lightning Induced Current Surges on Buried Multicoaxial Cable System," Wire Journal, Jan. 1973
3. IEEE Transactions on Communications October 1973. Lightning Surges in Open Wire, Coaxial, and Paired Cables - by Eric Bennison, Azel J. Ghaxi, and Pierre Ferland
4. G. K. Huddleston, J. D. Nordgard, R. W. Larson, FAA Lightning Protection Study: Lightning Requirements For AN/GRN-27(v) Instrument Landing System
5. Polniaszek, Joseph J., Jr., "The Solid State Lightning Simulator" Rome Air Development Center RADC-TM-76-10, June 1976
6. Final Test Report, AN/GRN-27(v) SSILS Lightning Fix Project, Electronics Systems Division, Sept. 1975
7. Military Specification MIL-S-19500/434 27 February 1970, Semiconductor Device, Diode, Silicon, Transient Suppressor TX and Non-TX Types IN5555 through IN5558 and IN5610 through IN5613

MISSION
of
Rome Air Development Center

RADC plans and conducts research, exploratory and advanced development programs in command, control, and communications (C³) activities, and in the C³ areas of information sciences and intelligence. The principal technical mission areas are communications, electromagnetic guidance and control, surveillance of ground and aerospace objects, intelligence data collection and handling, information system technology, ionospheric propagation, solid state sciences, microwave physics and electronic reliability, maintainability and compatibility.



Printed by
United States Air Force
Hanscom AFB, Mass. 01731