

**U.S. DEPARTMENT OF COMMERCE**  
**National Technical Information Service**

AD-A033 755

EVALUATION OF LOAD-BEARING HONEYCOMB  
CORE SANDWICH PANELS

CONSTRUCTION ENGINEERING RESEARCH  
LABORATORY (ARMY), CHAMPAIGN, ILLINOIS

NOVEMBER 1976

004030

construction  
engineering  
research  
laboratory

TECHNICAL REPORT D-75  
November 1976  
Performance Testing Relocatable Building Panels

ADA033755

EVALUATION OF LOAD-BEARING HONEYCOMB  
CORE SANDWICH PANELS

by  
Edward J. Worrel  
Bruce H. Wendler

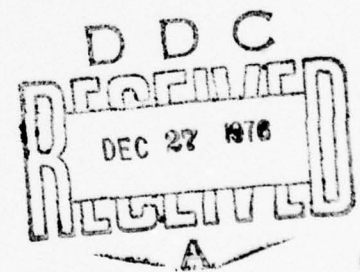
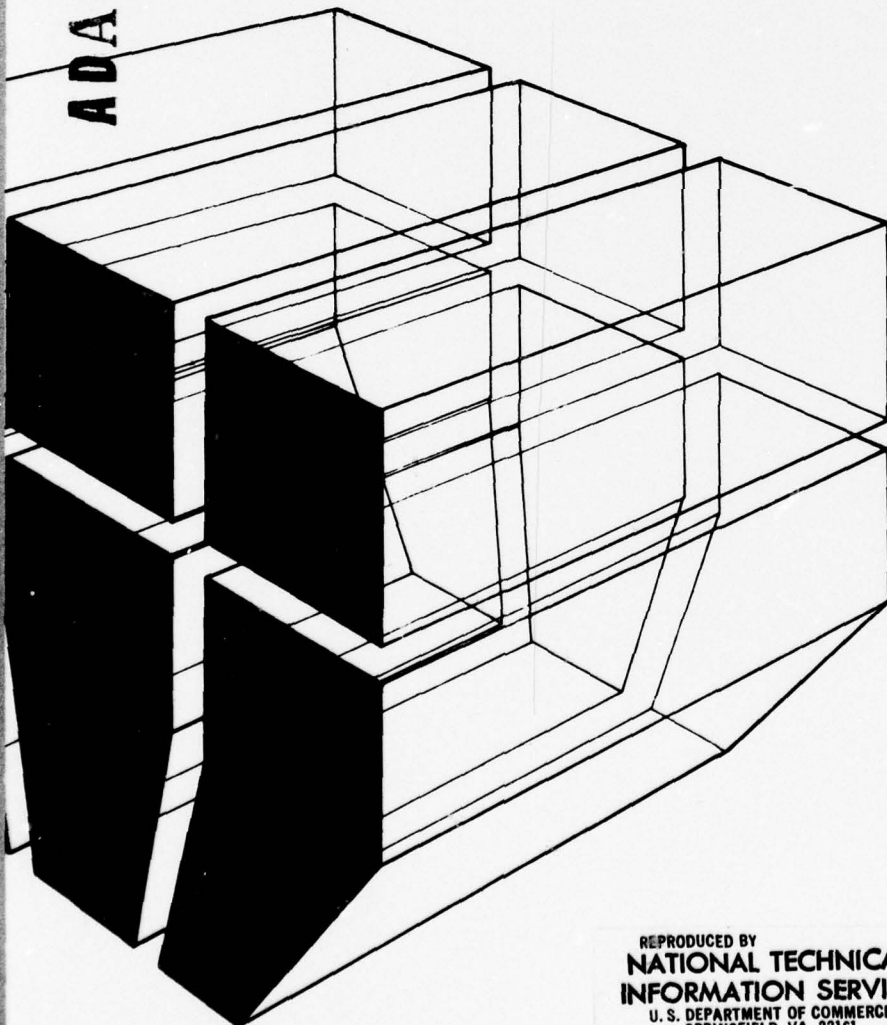

REPRODUCED BY  
NATIONAL TECHNICAL  
INFORMATION SERVICE  
U. S. DEPARTMENT OF COMMERCE  
SPRINGFIELD, VA. 22161



Approved for public release; distribution unlimited.

The contents of this report are not to be used for advertising, publication, or promotional purposes. Citation of trade names does not constitute an official indorsement or approval of the use of such commercial products. The findings of this report are not to be construed as an official Department of the Army position, unless so designated by other authorized documents.

**DESTROY THIS REPORT WHEN IT IS NO LONGER NEEDED  
DO NOT RETURN IT TO THE ORIGINATOR**

;

UNCLASSIFIED

SECURITY CLASSIFICATION OF THIS PAGE (When Data Entered)

REPORT DOCUMENTATION PAGE		READ INSTRUCTIONS BEFORE COMPLETING FORM
1. REPORT NUMBER CERL-TR-D-75	2. GOVT ACCESSION NO.	3. RECIPIENT'S CATALOG NUMBER
4. TITLE (and Subtitle) EVALUATION OF LOAD-BEARING HONEYCOMB CORE SANDWICH PANELS		5. TYPE OF REPORT & PERIOD COVERED FINAL
		6. PERFORMING ORG. REPORT NUMBER
7. AUTHOR(s) Edward J. Worrell Bruce H. Wendler		8. CONTRACT OR GRANT NUMBER(s)
9. PERFORMING ORGANIZATION NAME AND ADDRESS CONSTRUCTION ENGINEERING RESEARCH LABORATORY P.O. Box 4005 Champaign, IL 61820		10. PROGRAM ELEMENT, PROJECT, TASK AREA & WORK UNIT NUMBERS 4A762619AT41-T4-011
11. CONTROLLING OFFICE NAME AND ADDRESS		12. REPORT DATE November 1976
		13. NUMBER OF PAGES 56
14. MONITORING AGENCY NAME & ADDRESS (if different from Controlling Office)		15. SECURITY CLASS. (of this report) Unclassified
		15a. DECLASSIFICATION/DOWNGRADING SCHEDULE
16. DISTRIBUTION STATEMENT (of this Report) Approved for public release; distribution unlimited.		
17. DISTRIBUTION STATEMENT (of the abstract entered in Block 20, if different from Report)		
18. SUPPLEMENTARY NOTES  Copies are obtainable from National Technical Information Service Springfield, VA 22151		
19. KEY WORDS (Continue on reverse side if necessary and identify by block number) paper honeycomb core sandwich panels fire safety superficial damage		
20. ABSTRACT (Continue on reverse side if necessary and identify by block number)  This report describes an investigation of the performance of three-ply and five-ply paper honeycomb core sandwich panels. The core of the three-ply material consisted of metallic skins bonded to a cellular paper ply; the five-ply construction had 1/8-in. (3.2 mm) hardboard or asbestos board bonded to the metal skin which was bonded to the honeycomb paper. The panels were tested for fire safety, superficial damage, thermal conductivity, and durability. It was found that addition of backup plies did not significantly affect performance in thermal conductivity, durability, or large import loads; however, a signif-		

cut  
UNCLASSIFIED

SECURITY CLASSIFICATION OF THIS PAGE(When Data Entered)

Block 20 continued.

icant increase in performance was achieved in localized superficial damage and fire endurance times. The improved fire performance of the five-ply panels was still decidedly inferior to that of conventional wood stud construction. Further study should be made to determine if simple changes in the basic design of the panel are available which could bring the fire performance up to the level of conventional construction.

## FOREWORD

This research was performed for the Directorate of Military Construction, Office of the Chief of Engineers (OCE) under Project 4A762619AT41, "Design, Construction and Operation and Maintenance Technology for Military Facilities," Task T4, "Construction Systems Technology," Work Unit 011, "Performance Testing Relocatable Building Panels," and for the U.S. Army Corps of Engineers Division, Pacific Ocean under reimbursable order number PODSP-MIL-76-13, 31 Oct 75. Mr. Bill Johnson was the OCE Technical Monitor.

The work was performed by the Master Planning and Systems Building Branch of the Habitability and Planning Division (HP) and the Structural Mechanics Branch of the Materials Systems and Science Division (MS), U.S. Army Construction Engineering Research Laboratory (CERL), Champaign, IL; U.S. Department of Agriculture Forest Service, Forest Products Laboratory, Madison, WI; U.S. Army Natick Development Center, Natick, MA; and Dynatech R/D Company, Cambridge, MA. The CERL Principal Investigator was Mr. Edward J. Worrel, and the Associate Investigator was Mr. Bruce Wendler.

Appreciation is expressed to Mr. G. McSwain and Dr. H. Eckner (Forest Products Laboratory), Dr. A.M. Kaplan (Natick Development Center), and Messrs. T. Kenney, R. Schneider, J. Gill, and J. Gambill (CERL) for their assistance in conducting the testing program.

Dr. D.G. Bagby is Chief of the Master Planning and Systems Building Branch and Dr. W.E. Fisher is Chief of the Structural Mechanics Branch. Dr. M. Dinnat is Chief of HP and Dr. G.R. Williamson is Chief of MS. COL J.E. Hays is Commander and Director of CERL and Dr. L.R. Shaffer is Deputy Director.

ACCESSION FOR	
NTIS	<input checked="" type="checkbox"/>
DOC	<input type="checkbox"/>
UNANNOUNCED	<input type="checkbox"/>
JUSTIFICATION	.....
BY.....	
DISTRIBUTION/AVAILABILITY CODES	
Dist.	AVAIL. CODE or SPECIAL
A	

## CONTENTS

DD FORM 1473	1
FOREWORD	3
LIST OF FIGURES AND TABLES	5
<b>1 INTRODUCTION</b> .....	<b>7</b>
Purpose	
Approach	
<b>2 PROCUREMENT OF PANELS FOR TESTING</b> .....	<b>7</b>
Assessment of Industry	
Response of Industry	
<b>3 DEVELOPMENT OF THE PERFORMANCE TEST SERIES</b> .....	<b>9</b>
Required Attributes	
Available Data	
Development of Additional Tests	
<b>4 TEST PROCEDURES AND RESULTS</b> .....	<b>10</b>
Fire Resistance	
Superficial Damage	
Thermal Conductivity	
Durability	
Test Results and Design Implications	
<b>5 CONCLUSIONS AND RECOMMENDATIONS</b> .....	<b>25</b>
Conclusions	
Recommendations	
<b>REFERENCES</b>	<b>26</b>
<b>APPENDIX A: Description of Manufacturers' Panels</b>	<b>27</b>
<b>APPENDIX B: Puncture Resistance Test Procedure</b>	<b>28</b>
<b>APPENDIX C: Resistance to Puncture and Tear Propagation Test Procedure</b>	<b>32</b>
<b>APPENDIX D: Impact Test Procedure</b>	<b>35</b>
<b>APPENDIX E: Data from Puncture Resistance Test</b>	<b>38</b>
<b>APPENDIX F: Data from Resistance to Puncture and Tear Propagation Test</b>	<b>46</b>
<b>APPENDIX G: Data from Adhesive Failure Test</b>	<b>54</b>
<b>APPENDIX H: Results of Thermal Conductivity Tests</b>	<b>56</b>
<b>DISTRIBUTION</b>	

## FIGURES

<b>Number</b>	<b>Page</b>
1 Five-Ply Honeycomb Core Sandwich Panel	8
2 Fire Endurance Times	14
3 Wall Section (8 ft x 19 ft [2.4 m x 3.0 m]) in Place During Fire Endurance Test	15
4 Structural Failure of Wall Section, Unexposed Side	16
5 Exposed Side of an Aluminum Skin Honeycomb Panel After the ASTM E-119 Fire Endurance Test	17
6 Results of Puncture Test	19
7 Results of Puncture-Tear Propagation Test	19
8 Results of Impact Test on Steel Panels	20
9 Results of Impact Test on Aluminum Panels	21
10 Results of Adhesive Failure Test	22
11 Thermal Transmittance Values for Steel Skin Panels	23
12 Thermal Transmittance Values for Aluminum Skin Panels	24
B1 Puncture Test Arrangement	28
B2 Test Apparatus Setup With Bit Type B	29
B3 Close-Up of Test Apparatus Setup With Sharp Bit, Type A	29
B4 Excitation Curve for Decaying Velocity Puncture Test	30
B5 Sample Test Data Sheet	31
C1 Puncture and Tear Propagation Test Apparatus	32
C2 View of the Apparatus After Tearing the Surface of a Three-Ply Panel	32
C3 Picture of Bits B (Upper) and A (Lower)	33
C4 Sample Data Sheet	34
D1 Impact Test Apparatus	36
D2 Deflection Targets Located on the Side of a Wall Specimen	36
D3 Functional Representation of Data Collection Equipment	37

## TABLES

Number	Page
1 Test Responsibilities for Organizations Participating in Test Program	7
2 Manufacturers Receiving Request for Quotations	7
3 Specifications Provided to Manufacturers	8
4 Additional RFQ Requirements	8
5 Product Comparison	9
6 Manufacturer A Honeycomb Core Test Panel Weight Information	9
7 Manufacturer B Honeycomb Core Test Panel Weight Information	9
8 Manufacturer C Honeycomb Core Test Panel Weight Information	9
9 List of Standards for Major Attribute Areas of Honeycomb Core Sandwich Panels Testing Program	11
10 Eight-ft (2.4 m) Tunnel Results (ASTM E-286) for Aluminum Facings on 3-in. (7.6 cm) Thick Paper Honeycomb Core Wall Panels Furnished by Manufacturer A	12
11 Eight-ft (2.4 m) Tunnel Results (ASTM E-286) for Aluminum Facings on 2 31/32-in. (7.5 cm) Thick Paper Honeycomb Core Wall Panels Furnished by Manufacturer B	13
12 Eight-ft (2.4 m) Tunnel Results (ASTM E-286) for Aluminum Facings on 3-in. (7.6 cm) Thick Paper Honeycomb Core Wall Panels Furnished by Manufacturer C	13

# EVALUATION OF LOAD-BEARING HONEY-COMB CORE SANDWICH PANELS

## 1 INTRODUCTION

### Purpose

The purpose of this study was to test and evaluate load-bearing paper honeycomb core sandwich panels produced by at least three manufacturers. Since panels with either aluminum or steel exterior skins and with or without exterior skin backing of hardboard or asbestos cement board are available, the study included testing of the various combinations of materials. The results of this study should assist in providing missing technical information on the panel characteristics and in identifying the strengths and weaknesses of the various types of panels.

### Approach

This study was conducted in three phases: (1) procurement of panels for testing, including identification of manufacturers of sandwich panels and required panel characteristics, and taking of bids; (2) development of the performance test series; and (3) testing and evaluation. Organizations participating in the program and their responsibilities are shown in Table 1. Chapter 2 discusses the first phase of the study. Chapter 3 briefly discusses the development of the performance test series, and Chapter 4 presents the test procedures and results. Chapter 5 contains conclusions and recommendations.

## 2 PROCUREMENT OF PANELS FOR TESTING

### Assessment of Industry

The initial steps taken in this study were to identify the manufacturers who produce sandwich panels (Table 2) and the panel characteristics required for testing (Table 3). Since manufacturers can fabricate panels of multiple thicknesses, the specifications in Table 3 cover panels with and without an additional layer of material laminated between the honeycomb core and the exterior skin. These panels are referred to as five-ply and three-ply respectively. Figure 1 illustrates the composition of the five-ply panel. A request for quotations (RFQ) was developed and sent to each manufacturer identified in Table 2.

In addition to the requirements of Table 3, each manufacturer was required to supply the quantity breakdown and assembly-mounting material identified in Table 4. Each firm was requested to provide sufficient documentation to completely identify each item, including percent resin impregnation, adhesion per square foot, standard fire retardant, and details on surface precoat material (Appendix A).

Table 1

Test Responsibilities for Organizations Participating in Test Program

Organization	Test Responsibilities
1. U.S. Army Construction Engineering Research Laboratory, Champaign, IL	a. Puncture resistance b. Resistance to puncture-propagation of tear. c. Impact test.
2. U.S. Department of Agriculture Forest Service Products Laboratory, Madison, WI	a. Fire test of building construction and material. b. Surface flammability of building material. c. Climbing drum peel test for adhesives.
3. U.S. Army Natick Development Center, Natick, MA	a. Tropic chamber test for fungus degradation. b. Soil-burial test for fungus propagation.
4. Dynatech R/D Company, Cambridge, MA	a. Thermal conductivity.

Table 2

Manufacturers Receiving Request for Quotations

Panelfab Miami, FL	Florida Industries, Inc. Tampa, FL
Endur-A-Lifetime Miami, FL	Buckingham Wood Products Rapid City, SD
Alliance Wall Corp. Alliance, OH	National Homes Corp Lafayette, IN
Midwest Architectural Metal Chicago, IL	Central Building Systems East Troy, WI
Mapes Industries, Inc. Lincoln, NE	Fish Building Supply Middleton, WI
Johns-Manville Denver, CO	North Components Green Bay, WI
ALCO Chicago, IL	Geodesic Structure, Inc. Hightstown, NJ
Walcon Corp. Ecorse, MI	Material Fabrication Hainesport, NJ
Carew Corporation York, PA	Factory Built Homes Pittsburgh, PA
Connell Bros. Company LTD San Francisco, CA	Precision Struct. Compon. Fort Lauderdale, FL

**Table 3**

**Specifications Provided to Manufacturers**  
Provide 24 honeycomb core sandwich panels,  
using various core fillers.

**Characteristics of Panels**

1. Load bearing, roof and wall (self-framing construction).
2. 4 ft x 8 ft (1.2 m x 2.4 m) size.
3. 3-in. (7.6 cm) nominal thickness core face to face.
4. Twenty-six gauge steel exterior surface on both sides or, Aluminum exterior surface on both sides, .025 (+.001) thickness of aluminum or manufacturer's standard thickness.
5. Surface having precoat surface of a material of manufacturer's choosing, or exposed metal.
6. Backup in five-ply panel to be hardboard or cement asbestos board.
7. Honeycomb cores to be 70 to 80 lb (31 to 36 kg) Kraft paper, 1/2 in. (1.3 mm) cell. Cores shall have the manufacturer's standard fire retardant. Finished panels shall have a flame spread of 25 or less.
8. Panels to be structural laminated unit. Three-ply laminate shall be metal, honeycomb, metal; five-ply laminate shall be metal, backup, honeycomb, backup, metal.
9. Honeycomb cores shall have manufacturer's standard resin impregnation.
10. The adhesion used in bonding the cores to a rigid surface on a multi-ply material shall be conducted according to the manufacturer's standard procedures.

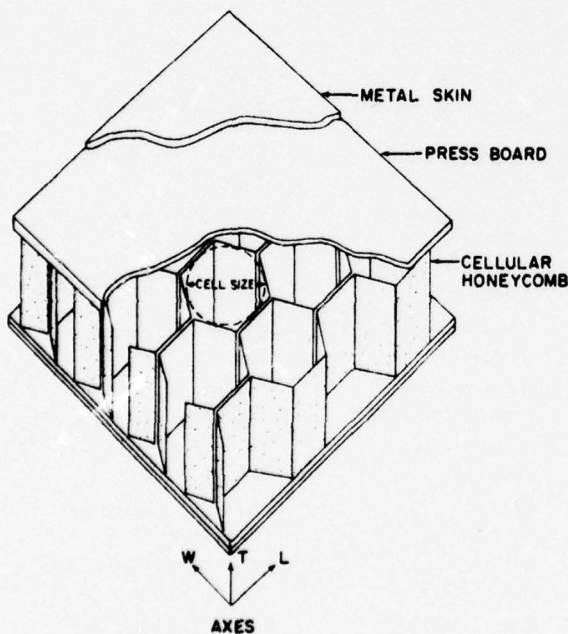

**Figure 1.** Five-ply honeycomb core sandwich panel.

**Table 4**

**Additional RFQ Requirements**

**Quantity Breakdown**

- Three-ply styrofoam pellet-filled honeycomb core sandwich panel
- Five-ply styrofoam pellet-filled honeycomb core sandwich panel
- Three-ply moisture-resistant perlite-filled honeycomb core sandwich panel
- Five-ply moisture-resistant perlite-filled honeycomb core sandwich panel
- Three-ply unfilled honeycomb core sandwich panel
- Five-ply unfilled honeycomb core sandwich panel

**Assembly-Mounting Material**

- Base mounting assembly
- Vertical joint strip
- Horizontal joint strip
- Top (roof) mounting assembly

**Response of Industry**

Only three responsive proposals were received. Of the three proposers, one (Manufacturer C) provided panels with only a steel exterior skin, one (Manufacturer A) provided both steel and aluminum exterior skins, and the third (Manufacturer B) provided exterior skin of aluminum. Manufacturer C identified its core fill material as vermiculite, Manufacturer A identified its core fill material as polystyrene or vermiculite, and Manufacturer B identified its core fill material as vermiculite or styrofoam. Table 5 identifies the similarities in characteristics among the three manufacturers' products.

Upon receipt of the panels from each firm, the panels were marked and weighed. Tables 6 through 8 identify the average weight per manufacturer per test panel type. Each panel was inspected to determine if any damage had occurred during the shipping process. All manufacturers shipped their panels in individual cardboard containers, and no serious damage to the exterior skin was observed. One manufacturer had serious skin separation on the three-ply vermiculite-filled panel. An inspection of this panel revealed that several cells were relatively void. It was assumed from the condition of the panel that there was improper quality control. Inspection of the other manufacturers' products revealed that the core fill material completely occupied the cells.

**Table 5**  
**Product Comparison**

Product Characteristics	Manufacturer		
	A	B	C
Exterior Skin Material:			
Aluminum	X	X	
Steel	X		X
Core Fill Material:			
Polystyrene	X		
Styrofoam		X	
Vermiculite	X	X	X
Unfilled	X	X	X
Exterior Skin Backing Material:			
Hardboard	X	X	
Asbestos Cement Board			X

**Table 6**  
**Manufacturer A**  
**Honeycomb Core Test Panel Weight Information**  
(4 x 8 ft [1.2 x 2.4 m] panels, 3 in. [7.6 cm] nominal thickness)

Type	Fill Material	Average Weight
Aluminum three-ply	Unfilled	41.0 lb (18.6 kg)
	Polystyrene	46.0 lb (20.9 kg)
	Vermiculite	80.0 lb (36.3 kg)
Aluminum five-ply	Unfilled	85.0 lb (38.6 kg)
	Polystyrene	93.0 lb (42.2 kg)
	Vermiculite	130.0 lb (59.0 kg)
Steel three-ply	Unfilled	66.0 lb (29.9 kg)
Steel five-ply	Unfilled	112.0 lb (50.8 kg)

**Table 7**  
**Manufacturer B**  
**Honeycomb Core Test Panel Weight Information**  
(4 x 8 ft [1.2 x 2.4 m] panels, 3 in. [7.6 cm] nominal thickness)

Type	Fill Material	Average Weight
Aluminum three-ply	Unfilled	40.5 lb (18.4 kg)
	Styrofoam	43.5 lb (19.7 kg)
	Vermiculite	106.0 lb (48.1 kg)
Aluminum five-ply	Unfilled	82.5 lb (37.4 kg)
	Styrofoam	86.0 lb (39.0 kg)
	Vermiculite	140.5 lb (63.7 kg)

**Table 8**  
**Manufacturer C**  
**Honeycomb Core Test Panel Weight Information**  
(4 x 8 ft [1.2 x 2.4 m] panels, 3 in. [7.6 cm] nominal thickness)

Type	Fill Material	Average Weight
Steel three-ply	Vermiculite	115.0 lb (52.2 kg)
	Unfilled	73.0 lb (33.1 kg)
Steel five-ply	Vermiculite	185.0 lb (83.9 kg)
	Unfilled	147.0 lb (66.7 kg)

### 3 DEVELOPMENT OF THE PERFORMANCE TEST SERIES

The objective of this program was to provide performance-related data on three- and five-ply honeycomb core sandwich panels. Formulation of the program included: (1) determining which attributes were important to the panels' relative performance; (2) analyzing the availability of test results for each attribute; and (3) developing a test program to provide data on the attributes which lacked coverage.

#### Required Attributes

To determine which attributes were important to the panels' relative performance, a 1973 report by the Forest Products Laboratory<sup>1</sup> was reviewed. This state-of-the-art report identifies seven areas which should be considered when analyzing the design and application of sandwich panels: (1) structural design, (2) fire safety, (3) acoustic environment, (4) dimensional stability, (5) thermal environment, (6) durability, and (7) construction quality. Initial investigation indicated that an eighth factor, "superficial damage," was important and should be considered as a key element. These eight attributes were considered important because, irrespective of material, they identify those areas which are essential to controlling the satisfactory performance of the facility.

#### Available Data

The next step was to determine whether tests and test results were available for these eight areas. After analyzing relevant tests, it was determined that considerable investigation had been conducted by other agencies on some of the above panel characteristics.

<sup>1</sup>Characteristics of Load-Bearing Sandwich Panels for Housing (Forest Products Laboratory, 1973).

For example, the structural integrity of the various panels can be obtained by examining the test results prepared by the manufacturers or laboratories performing evaluations of panel performance.<sup>2</sup> The classification of the panels as a noncombustible material<sup>3</sup> has been established based on the low flame spread rating obtained from the American Society for Testing and Materials (ASTM) Test E-84.<sup>4</sup> Reports and tests of flame spread ratings are available for a variety of materials. Some of the commonly required thermal property tests are also readily available from testing services. However, because of the wide range of materials and construction techniques, it was difficult to find thermal test results based on the specification in Table 3.

#### Development of Additional Tests

It was concluded that some of the areas had adequate documentation and required no additional tests, but other areas were not sufficiently covered. A decision was made to concentrate the analysis on the areas which lacked coverage. These areas were evaluated based on importance relative to the anticipated use for housing, type of required tests, length of time to perform associated tests, and criticality to the specification writer and/or architect. Based on this evaluation, the scope of the testing program was limited to fire safety, superficial damage threshold, thermal conductivity, and durability. Selection of specific tests for these areas (Table 9) was accomplished by consulting the ASTM standard test methods. Several test procedures designed for a different type of material were modified for application to the honeycomb core sandwich panels. For example, ASTM D-781 is designed to cover the determination of puncture and stiffness of paperboard, corrugated and solid fiberboard. Although strict interpretation of this standard's scope does not include coverage of the honeycomb core panel, the test was determined to be appropriate for this program because it provided information relative to the amount of energy required to tear the material and the amount of energy required to bend it out of the way of the puncture device. In every instance, the principles of the test being modified were maintained to comply with the ASTM standard.

<sup>2</sup>T.W. Reichard and E.V. Leyendecker, *Test and Evaluation of the Prefabricated Lewis Building and Its Components*, Report No. NBS-10163 (National Bureau of Standards, 1970); J.H. Pielert, T.W. Reichard, and L.W. Masters, *Structural Evaluation of Steel Faced Sandwich Panels* (National Bureau of Standards, 1974); *Characteristics of Load-Bearing Sandwich Panels for Housing* (Forest Products Laboratory, 1973), pp 7-9.

<sup>3</sup>*National Fire Codes*, Vol 9 (National Fire Protection Association, 1975).

<sup>4</sup>1970 *Annual Book of ASTM Standards*, Part 14, pp 412-421.

## 4 TEST PROCEDURES AND RESULTS

### Fire Resistance

The *National Fire Codes*,<sup>5</sup> drafted by the National Fire Protection Association (NFPA), specify standard tests which can be performed to determine the fire resistance ratings of construction materials. The "fire resistance" of a material can be determined by two tests which have been adopted by ASTM Committee E-5, under standards ASTM E-119<sup>6</sup> and E-84. A simpler counterpart of ASTM E-84 using a small specimen is defined under ASTM E-286.<sup>7</sup> These tests indicate the performance of the panels in a developed fire and the contribution of the panel material to fire development. The tests are summarized below.

#### *ASTM E-119 Fire Test of Building Construction and Materials*

This test is designed to determine the endurance time a nonbearing or bearing wall can withstand a developed fire before failure. It involves subjecting one side of a bearing wall to a controlled-temperature fire and timing the panel's load-carrying capacity. The test specifies a minimum specimen size of 100 sq ft (9.3 m<sup>2</sup>); however, to meet the test program's objectives, a 10 ft (3.0 m) wide and 8 ft (2.4 m) high wall section was used. Further information on the test procedures can be found in the 1970 *Annual Book of ASTM Standards*, Part 14.

#### *ASTM E-286 Test for Surface Flammability of Building Materials*

This test measures the flame spread, energy contribution, and smoke development of a test specimen. An 8 ft x 13-3/4 in. (2.4 m x 34.3 cm) specimen is mounted on the upper surface of a tunnel furnace in which a gas flame is placed under the end of the specimen. The data are reduced by comparing results of red oak to those of the material tested and specifying the relative "index" of the material. The 1970 *Annual Book of ASTM Standards*, Part 14, provides further details.

### Results

Results of the ASTM E-286 surface flammability test series indicate that the panels can be classified as a noncombustible material. Tables 10 through 12 present

<sup>5</sup>*National Fire Codes*, Vol 9 (National Fire Protection Association, 1975), pp 220-1 to 220-7.

<sup>6</sup>1970 *Annual Book of ASTM Standards*, Part 14, p 252.

<sup>7</sup>1970 *Annual Book of ASTM Standards*, Part 14, pp 412-42, 451-463.

Table 9

List of Standards for Major Attribute Areas of Honeycomb Core Sandwich Panels Testing Program

Attribute	ASTM Standard Number	Name of Standard	Remarks
Fire Safety	ASTM E-119	Fire Test of Building Construction and Materials	Procedure modified, specimen 80 sq ft (7.4 m <sup>2</sup> ), instead of 100 sq ft (9.3 m <sup>2</sup> )
	ASTM E-286	Test for Surface Flammability of Building Materials	
Superficial Damage	ASTM D-781	Puncture and Stiffness of Paperboard, Corrugated and Solid Fiberboard	Scope modified to include honeycomb core sandwich panels
	ASTM D-2582	Propagation Tear Resistance of Plastic Film and Thin Sheeting	Scope modified to include honeycomb core sandwich panels
	ASTM E-72	Standard Methods of Conducting Strength Tests of Panels for Building Construction	Impact load specimen vertical scope modified to include honeycomb core sandwich panels
	ASTM D-1781	Climbing Drum Peel Test for Adhesives	
Thermal Environment	ASTM C-518	Thermal Conductivity by the Heat Flow Meter	
Durability	Federal Test Method Standard #191, Method #5762.1	Soil Burial	
	ASTM G-21	Determining Resistance of Synthetic Polymeric Material to Fungi	
	MIL Standard 810b, Method 508	Tropical Chamber Exposure	95 percent relative humidity, 85°F (29°C) procedures modified: samples not inoculated with fungus material

the indexes of the panels. The indexes are basically the ratio of the measured result of the materials over the measured result of red oak, times 100. The smoke index was significant for the five-ply panels of manufacturers A and B but not for those of manufacturer C (Table 12), because manufacturer C's panels had 1/8-in. (3.2 mm) asbestos board rather than 1/8-in. (3.2 mm) hardboard plies like those of manufacturers A and B.

The polystyrene insulative material had a smoke index greater than 100 and caused concern over the "toxicity" of the fumes. Specimens 1829 (Table 10) and 1833 (Table 11) experienced burns through the metal skins causing their insulative fill to fall into the flame, and increasing the flame spread index. These outbreaks may indicate unforeseen problems with the flame spread of the panels.

Table 10

**Eight-ft (2.4 m) Tunnel Results (ASTM E-286) for Aluminum Facings  
on 3-in. (7.6 cm) Thick Paper Honeycomb Core Wall Panels  
Furnished by Manufacturer A**

Test No.	Construction*	Index Values			
		Flame Spread	Heat Contribution	Smoke F**	It†
1824	Three-ply with polystyrene bead insulation	0	0	119	158
1825	Five-ply with vermiculite insulation	0	0	214	121
1826	Three-ply, no insulation	0	0	70	89
1827	Three-ply with vermiculite insulation	0	0	59	107
1829	Five-ply with polystyrene insulation	14††	2	167	166
1830	Five-ply, no insulation	3#	0	182	143

\* Three-ply has no hardboard under aluminum facing. Five-ply has 1/8-in. (3.2 mm) hardboard. Aluminum facing is 0.027 in. (0.7 mm) thick.

\*\* F = Fireye system.

† I = Integrator system.

†† At 16.4 min, hole burned through aluminum skin at 0- to 3-in. (0 to 7.6 cm) area. Flame turned slightly blue. At 18.3 min, gas flames flared to 12 in. (0.3 m). Some metal fell at 3- to 6-in. (7.6- to 15.2 cm) length.

# At 12.2 min, flame appeared at the 3-in (7.6 cm) area due to gas flowing across that area from bottom edge of specimen. At 17.75 min, skin had developed a bullet-shaped bubble of molten metal near bottom seal and about 2 in. (5.1 cm) from flame.

Most of the honeycomb panels failed in the ASTM E-110 fire endurance test before the first specification in the fire temperature curve (in 5 min over temperature will be 1000°F [538°C]). As can be seen in Figure 2, the three-ply panels failed in less than 1 1/2 min. The data indicate that the addition of extra plies at least doubled the fire endurance times. The five-ply panels with the 1/8-in. (3.2 mm) asbestos boards manufactured by company C had the highest fire endurance time—8 min 11 sec. Problems arise from the fact that steel and aluminum sheeting reach a low yield level before 1000°F (538°C). The adhesive bond fails in the heat, causing the panel facings to bow out, exposing the core to the fire. Figures 3 through 5 are examples of the failure experienced by the panels. Conventional 2 x 4 stud wall construction with drywall facings has been found to provide at least 20 min of structural support in the

ASTM E-119 test.<sup>8</sup> Thus, the comparatively low fire endurance times of honeycomb panels need further consideration.

#### Superficial Damage

Cosmetic damage to panels includes dents, tears, punctures, or other disfiguring damage caused by an impact against the panel which does not cause the facility to fail or stop functioning. To evaluate the performance of honeycomb panels against superficial damage, a search was made for existing standard test procedures for puncture, tear, impact, and adhesive failure. The main reference consulted was *Annual Book of ASTM Standards*. The standards having a principle or procedure applicable to industrialized panels are:

<sup>8</sup>1970 *Annual Book of ASTM Standards*, Part 14, p 252.

**Table 11**  
**Eight-ft (2.4 m) Tunnel Results (ASTM E-286) for Aluminum Facings**  
**on 2 31/32-in. (7.5 cm) Thick Paper Honeycomb Core Wall Panels**  
**Furnished by Manufacturer B**

Test No.	Construction*	Index Values			
		Flame Spread	Heat Contribution	Smoke F**	I†
1831	Five-ply with polystyrene bead insulation	0	0	223	198
1832	Five-ply, no insulation	0	0	235	211
1833	Five-ply with vermiculite insulation	31††	0	223	233
1834	Three-ply with polystyrene bead insulation	0	1	154	138
1835	Three-ply, no insulation	0	0	30	63
1836	Three-ply with vermiculite insulation	0	0	23	36

\* Three-ply has no hardboard under aluminum facing. Five-ply has 1/8-in. (3.2 mm) hardboard. Aluminum facing is 0.027 in. (0.7 mm) thick.

\*\* Fireeye system.

† Integrator system.

†† At 15.1 min, hole melted through skin at 3 to 6 in. (7.6 to 15.2 cm). Vermiculite poured through, with flames running up to 27 in. (68.6 cm). At 17.2 min, section from 0 to 15 in. (0 to 30.1 cm) fell down. Flames moved to top edge of panel from fallen section.

**Table 12**  
**Eight-ft (2.4 m) Tunnel Results (ASTM E-286) for Aluminum Facings**  
**on 3-in. (7.6 cm) Thick Paper Honeycomb Core Wall Panels**  
**Furnished by Manufacturer C**

Test No.	Construction	Index Values			
		Flame Spread	Heat Contribution	Smoke F*	I**
1837	Five-ply, steel skins, paper honeycomb core, +1/8-in. (3.2 mm) cement type hardboard, no insulation	0	0	8	28
1838	Three-ply, steel skins, paper honeycomb core, no insulation	0	0	68	87
1839	Five-ply, steel skins, paper honeycomb core, +1/8-in. (3.2 mm) cement type hardboard, with vermiculite insulation	0	0	24	0
1840	Three-ply, steel skins, paper honeycomb core, with vermiculite insulation	0	0	62	54

\* Fireeye system.

\*\* Integrator system.

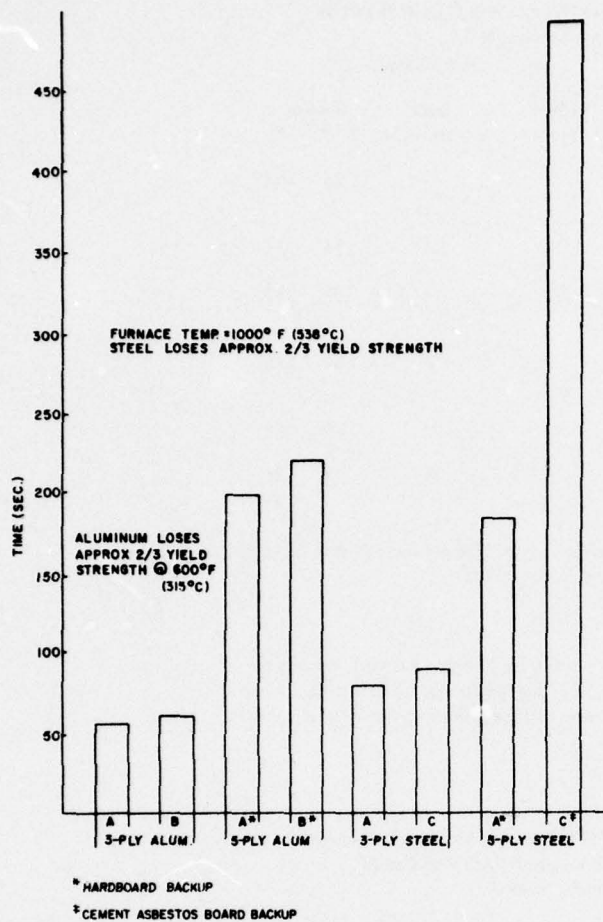

Figure 2. Fire endurance times.

1. For puncture—ASTM D-781, "Puncture and Stiffness of Paperboard, Corrugated, and Solid Fiberboard"<sup>9</sup>
2. For tear—ASTM D-2582, "Propagation Tear Resistance of Plastic Film and Thin Sheeting"<sup>10</sup>
3. For impacts—ASTM E-72, "Conducting Strength Test of Panels for Building Construction," Section 12.4<sup>11</sup>
4. For adhesive failure—ASTM D-1781, "Standard Method for Climbing Drum Peel Test for Adhesives."<sup>12</sup>

<sup>9</sup> 1970 Annual Book of ASTM Standards, Part 16, pp 203-207.

<sup>10</sup> 1970 Annual Book of ASTM Standards, Part 27, pp 702-706.

<sup>11</sup> 1970 Annual Book of ASTM Standards, Part 14, pp 395-397.

<sup>12</sup> 1975 Annual Book of ASTM Standards, Part 22, pp 549-553.

Two of these test procedures, tests D-781 and D-2582, although not directly applicable to honeycomb panels because they were designed for specific materials, were determined to be useful in providing information to the test procedure. Tests E-72 and D-1781 were directly applicable.

It was expected that these tests would define the superficial damage threshold, thereby allowing an evaluation of whether the panels are adequate for the levels of impacts expected for different types of relocatable buildings. A brief discussion of the tests follows.

#### Puncture Resistance of Multi-Ply Industrial Panels

The principle of test D-781 was used in developing the puncture resistance test procedures used in this test program. This test uses a hydraulic load stroke device with a load cell and analog plotter. A bit can be mounted to the loading device and driven through the panel. For this study a 1/2-in. (1.3 cm) diameter bit was selected and driven through the panels at various speeds. The force required to drive the bit was recorded and plotted on an analog plotter as a force versus displacement curve. By determining the area under the curve, an indication of the work required to puncture a panel can be found. Appendix B identifies specific details of the test procedure.

#### Resistance to Puncture and Tear Propagation

This test was patterned after the procedure outlined in ASTM D-2582. The test used the energy of a falling weight with a bit mounted to its side. The bit punctured and tore the specimen's surface. Each 25 cm x 25 cm specimen tested in this study experienced at least five tear runs. Using the energy equation which describes the system, the tear resistance force can be determined. Thus, the effectiveness of skin material, plies, and bonding schemes of multi-ply panels can be evaluated. Appendix C gives specific details of the test.

#### Impact Test for Multi-Ply Panels

This test was patterned after the procedure outlined in standard ASTM E-72, Section 12.4. The procedure used a swing bag filled with sand which hits the center of a panel located in the center of a 10 ft wide x 8 ft high (3.0 m x 2.4 m) wall. The deflection of the center of the panel was recorded on analog tape, and inspections were made for damage. Data reduction consisted of comparing physical phenomena and deflections against the height of the bag drop. The set deflection is a measure of the superficial damage. Appendix D presents a detailed procedure of the test.

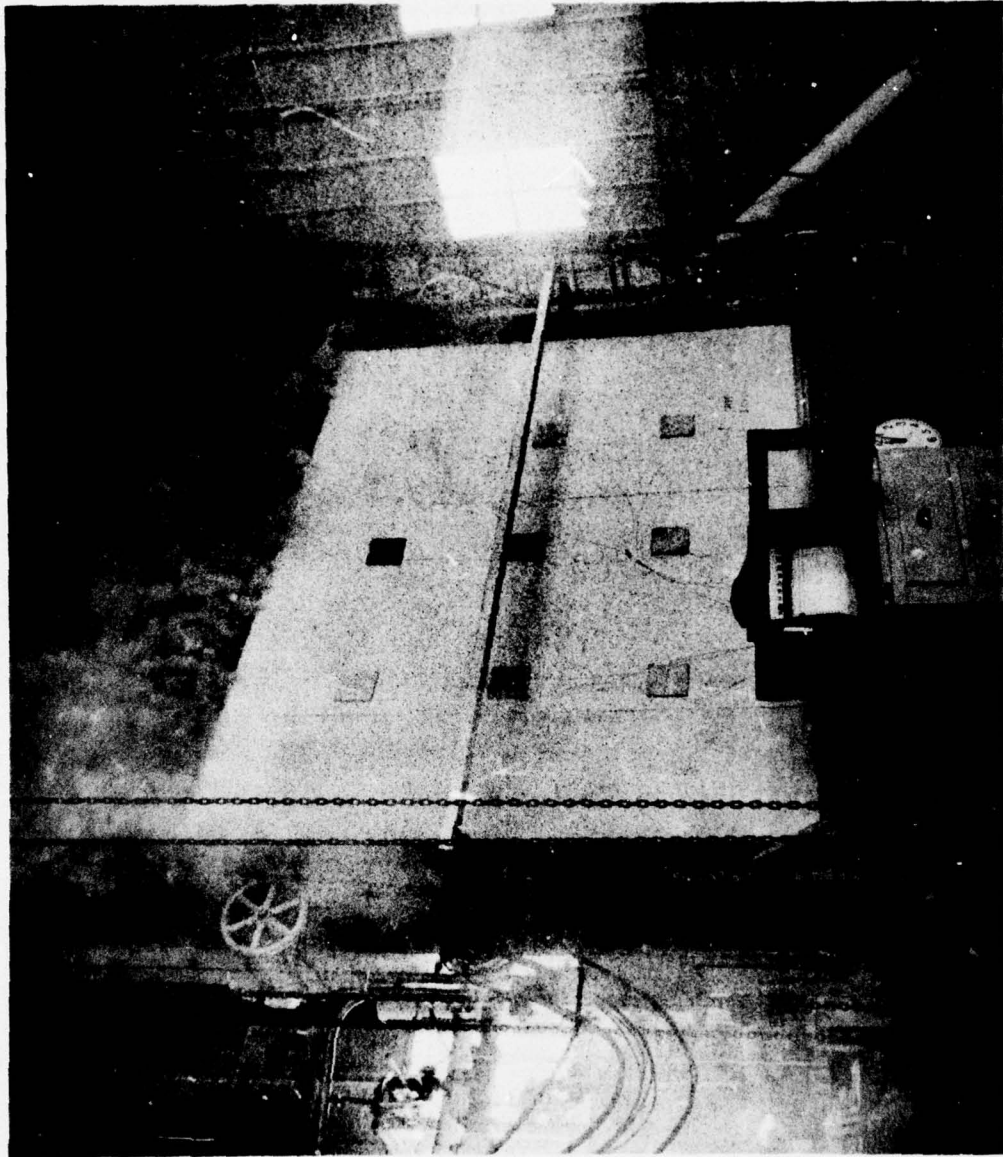

Figure 3. Wall section (8 ft x 10 ft [2.4 m x 3.0 m]) in place during fire endurance test.

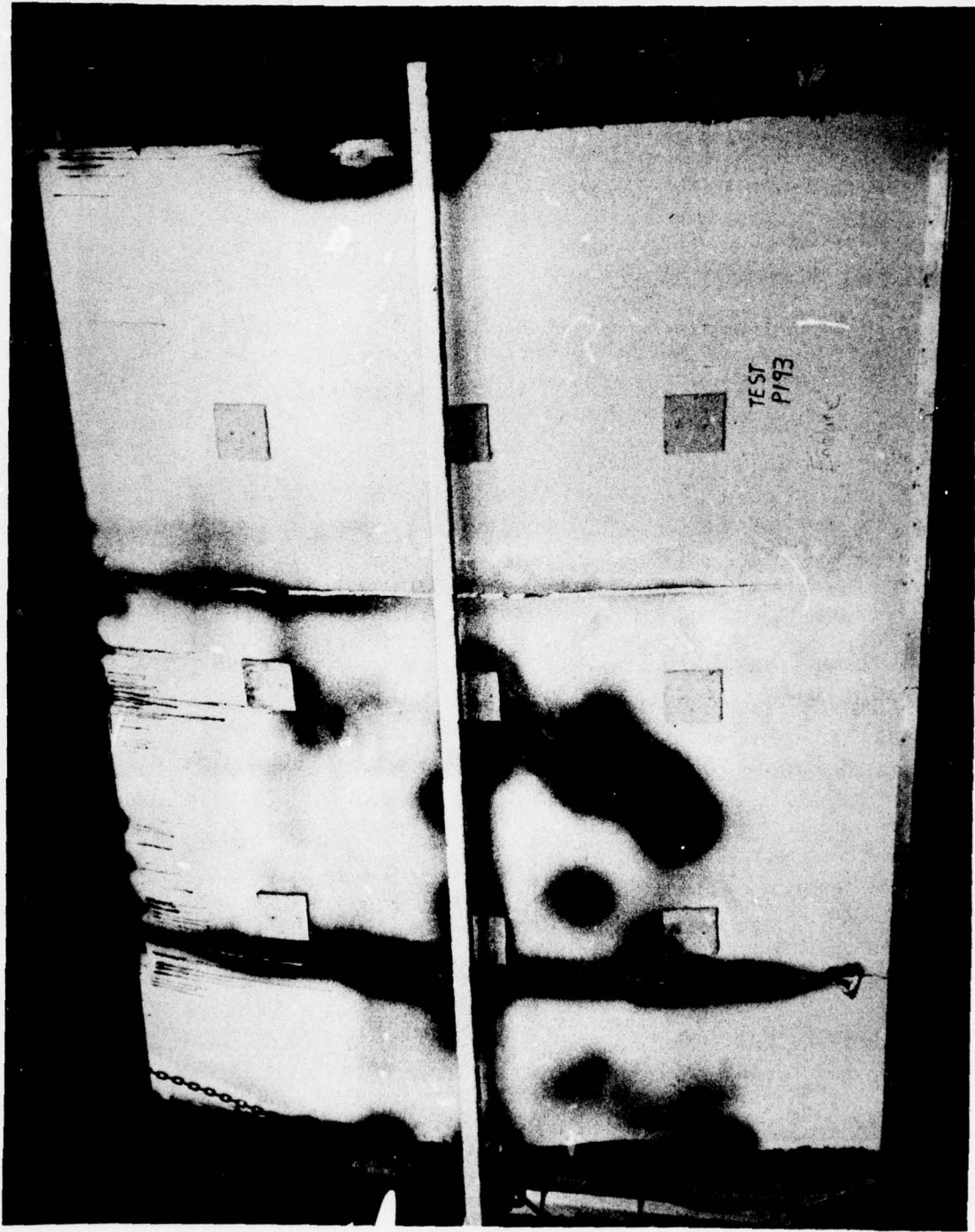
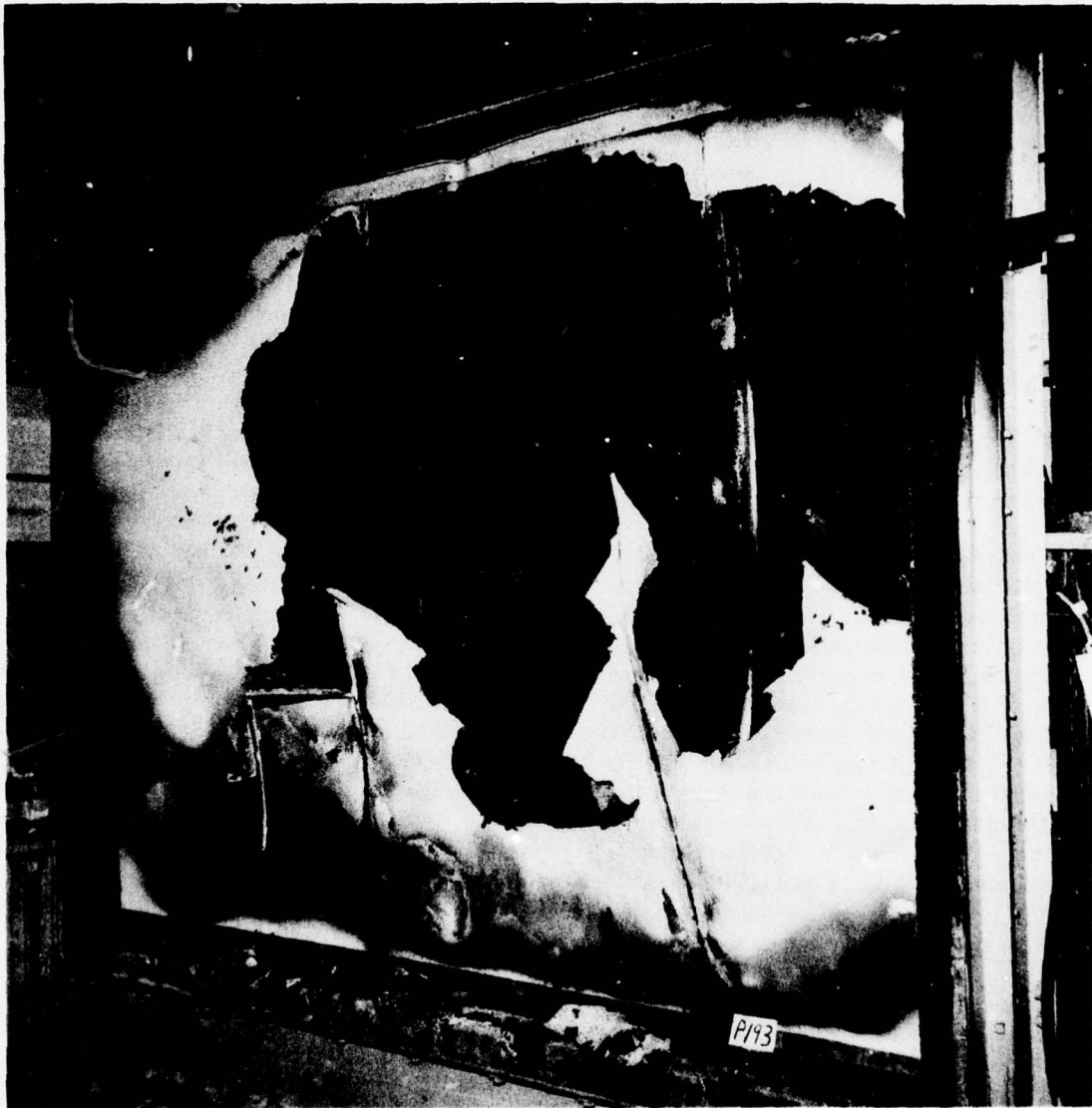

Figure 4. Structural failure of wall section, unexposed side.



**Figure 5.** Exposed side of an aluminum skin honeycomb panel after the ASTM E-119 fire endurance test.

#### *Adhesive Failure Test for Multi-Ply Panels*

This test procedure is outlined in ASTM D-1781. In this procedure, one metal skin surface of the panel is clamped to a 4-in. (10.2 cm) diameter drum, and the opposite metal skin is clamped to the top bar of a testing machine. The drum is rotated by tensile pressure applied from the bottom bar of the testing machine to straps on the drum flanges. The rotation of the drum causes the metal surface clamped to it to be peeled from the paper honeycomb substrate. The peel resistance of the bond between the metal skin and the inner ply is determined over a panel length of at least 6 in. (21.2 cm).

#### *Results of Functure and Puncture-Tear Tests*

Results indicate a large span of superficial damage thresholds is obtainable with paper honeycomb core panels. Data from the puncture test series (Figure 6 and Appendix E) show a range from 17 ft-lb (248 N-m) for the three-ply aluminum panels to 55 ft-lb (802.7 N-m) for the five-ply panels, an increase of 224 percent. Results from the puncture-tear propagation test (Figure 7 and Appendix F) indicate the addition of two 1/8-in. (3.2 mm) press board plies can improve panel tear resistance by 75 to 160 percent. These tests indicate that once the level of superficial damage resistance is specified for barracks, machine shops, kitchens, or other desired facilities, a combination of ply materials can meet the expected resistance level.

#### *Results of Impact and Adhesive Tests*

The impact test results (Figures 8 and 9) indicate that the panels can withstand a 7.5-ft (2.3 m) drop of a 60-lb (27.2 kg) sand bag before a set deflection of 1.5 in. (3.8 cm) occurs. This means a panel can withstand a 450-ft-lb (6567 N-m) impact level. Similar tests conducted by the National Bureau of Standards on 4 ft x 8 ft (1.2 m x 2.4 m) gypsum wall board construction indicated failure occurred before the 60-ft-lb (876 N-m) level of impact.<sup>13</sup> The impact resistance of the honeycomb core panels is significantly higher, indicating that the panels can be used in most facilities.

The results indicate that there is no significant difference between three-ply or five-ply steel or aluminum panels' resistance to impact damage; however, a correlation between a panel's adhesive bond and its impact resistance was indicated by the results of the adhesive failure test (Figure 10 and Appendix G). For example, the impact resistance and peel torque for a three-ply

panel of manufacturer B are 5.25 ft (1.6 m) drop (Figure 9, test run number divided by two) and 5.2 in.-lb/in. (75.9 N-m) (Figure 10), respectively; for manufacturer A's three-ply panel they are 7.75 ft (2.4 m) drop (Figure 9) and 9.5 in.-lb/in. (138.6 N-m) (Figure 10), respectively; for manufacturer C's five-ply panel the values are 11 ft (160.5 m) drop (Figure 8) and 16.3 in.-lb/in. (237.8 N-m) (Figure 10). These results indicate that impact resistance increased an average of .55 ft (0.2 m) drop height per in.-lb/in. of peel torque. A panel's direct performance level is not specified by a climbing drum test; however, determining the adhesive bond indicates a panel's structural integrity under impact loads.

#### **Thermal Conductivity**

##### *Test Procedure*

To improve the insulative quality of paper honeycomb core panels, an insulative fill such as vermiculite or styrofoam pellets is inserted into the cellular honeycomb cavities. A measure of the insulative property of a nonhomogeneous material is the thermal transmittance or the U value. The U value is defined as "the ratio of the steady state heat flux from the surroundings on one side of a body, through the body, to the surroundings on its opposite side."<sup>14</sup> One inexpensive method of obtaining a thermal conductance value of a material is through use of a heat flow meter. ASTM has adopted ASTM C-518<sup>15</sup> as a standard test procedure for using heat flow meters to obtain the thermal conductivity. A brief description of the test follows.

The test apparatus consists of a hot plate, a heat flow meter, the sample, and a cold plate. The hot and cold plates create a temperature differential across the sample. Readings are taken in Btu/hr sq ft °F. The sample size used in this study was 12 in. x 12 in. (0.3 x 0.3 m) by the thickness of the material. Since the panels had a metal skin, a 4 in. x 4 in. (10.2 x 10.2 cm) slit was cut through the metal to reduce heat flow across the surface. Results from the heat flow meter test (Appendix H) allow a comparison between the various ply and insulative fill types of panels.

##### *Results*

Figures 11 and 12 are graphs of the thermal transmittance values for three- and five-ply panels with insulative fill materials determined from the heat flow meter test. Military Specification MIL-B-28658B

<sup>13</sup>H.S. Lew, *Impact Test on Gypsum Wallboard* (National Bureau of Standards, 1970), pp 29-32.

<sup>14</sup>1970 *Annual Book of ASTM Standards*, Part 14.

<sup>15</sup>1970 *Annual Book of ASTM Standards*, Part 14, pp 210-218.

### WORK REQUIRED TO PUNCTURE PANEL

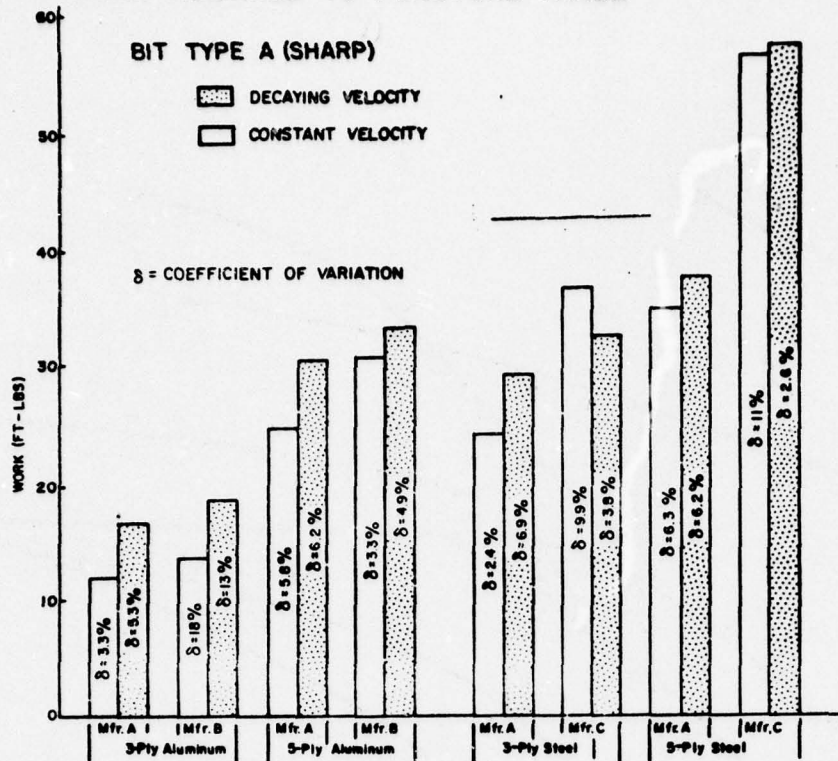

Figure 6. Results of puncture test. Metric conversion factor: 1 ft-lb = 14.59 N-m.

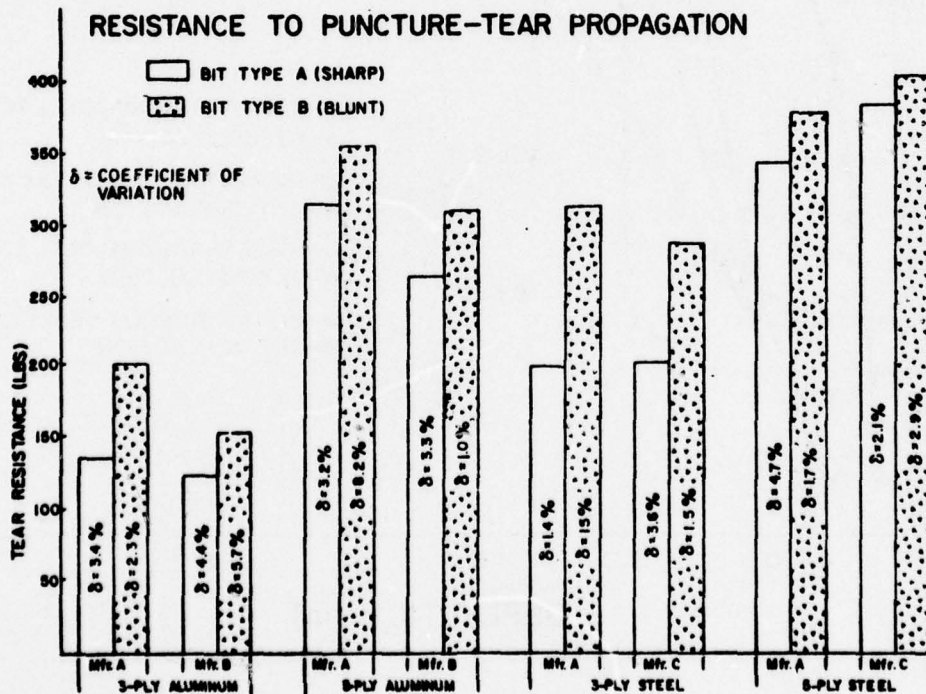

Figure 7. Results of puncture-tear propagation test. Metric conversion factor: 1 lb = 0.45 kg.

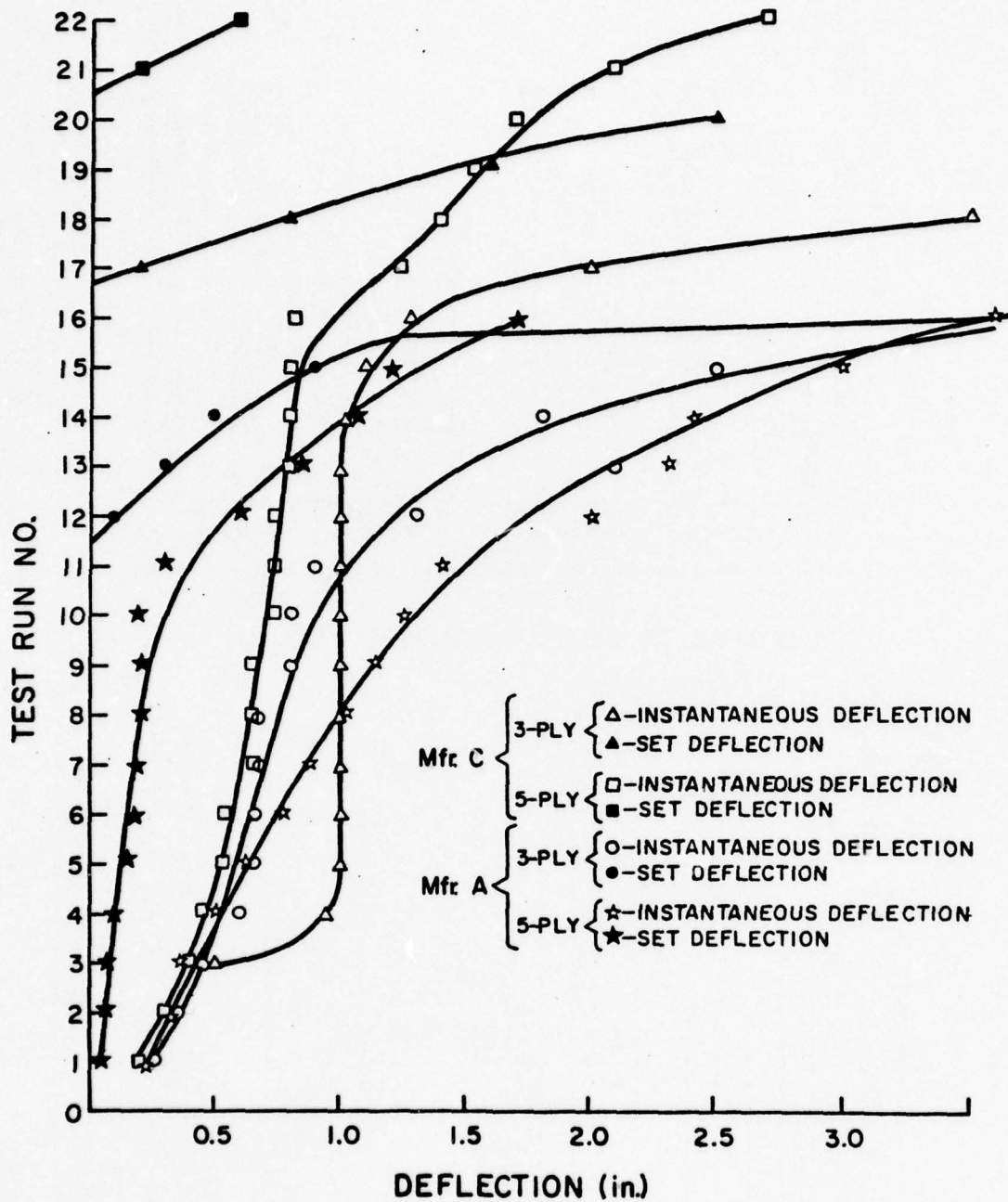

Figure 8. Results of impact test on steel panels. Metric conversion factor: 1 in. = 2.54 cm.

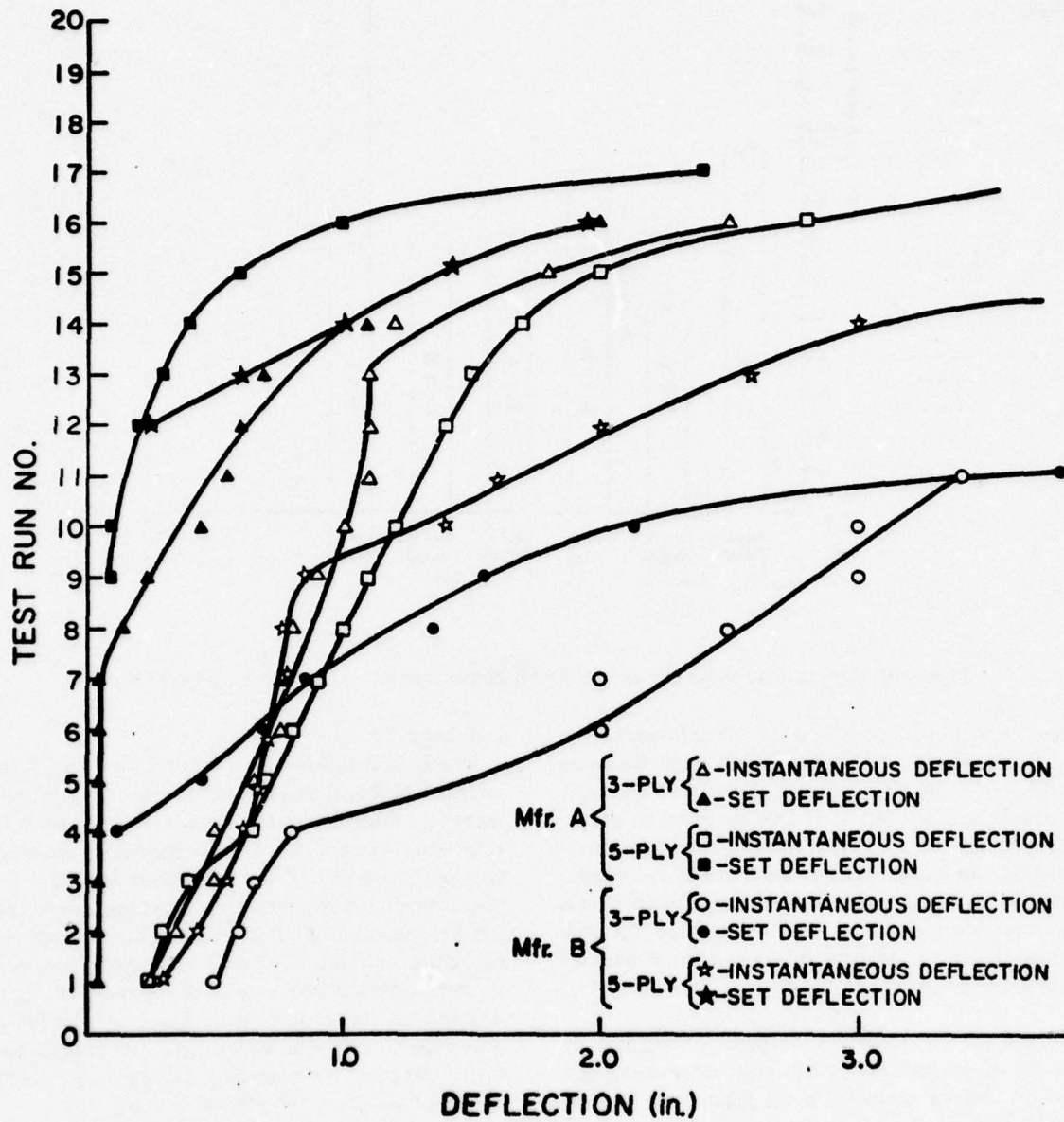

Figure 9. Results of impact test on aluminum panels. Metric conversion factor: 1 in. = 2.54 cm.

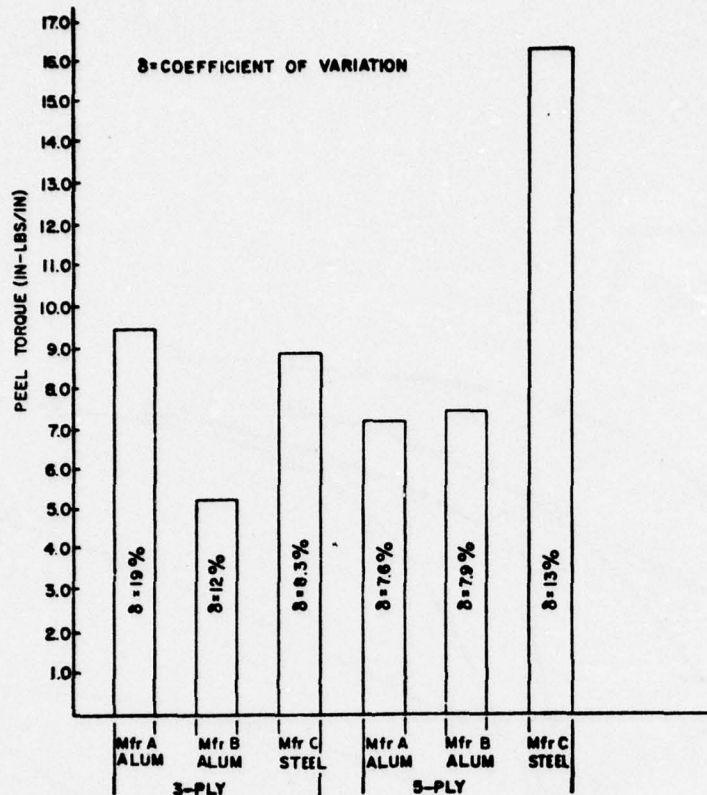

Figure 10. Results of adhesive failure test. Metric conversion factor: 1 in.-lb/in. = 14.59 N-m.

specifies that buildings have a U value of no more than 0.2 Btu/hr sq ft °F (1.1 W m<sup>2</sup> °K).<sup>16</sup> Since the values in Figures 11 and 12 were not determined using the Guarded Hot Box test technique specified in MIL-B-28658B, the tests do not constitute an acceptance criterion, but indicate the reduction in heat loss obtainable by use of insulative fills. Although exact figures were not obtained during this test program, the tests indicated that the U value of the panels will improve with lower temperatures.

Since the differences in the three-ply and five-ply panels are insignificant in this area, recommending a five-ply over a three-ply panel cannot be justified on this basis.

<sup>16</sup>Military Specification Building Components, Panelized, Prefabricated, Ready-Cut, Relocatable, MIL-B-28658B (Department of Defense, 1974), Specification 4.4.1.2.2.

#### Durability

The U.S. Army Natick Development Center tested samples of honeycomb core sandwich panels with hardboard backing from manufacturers A and B for microbial resistance in plate tests, soil burial, and tropic chamber exposures. Plate test results indicated that both manufacturers' panels supported fungal growth and had delamination of the materials. Concern expressed by Natick over the vulnerability of paper honeycomb to insect damage was confirmed when heavily resin-impregnated shelter-grade honeycomb samples (which were superior in microbial resistance to both manufacturers' samples) were severely damaged by termites during infestation of the tropical chamber.

Results of the microbial testing also indicated that both manufacturers' panels lost compressive strength at about the same rate in soil burial and tropical cham-

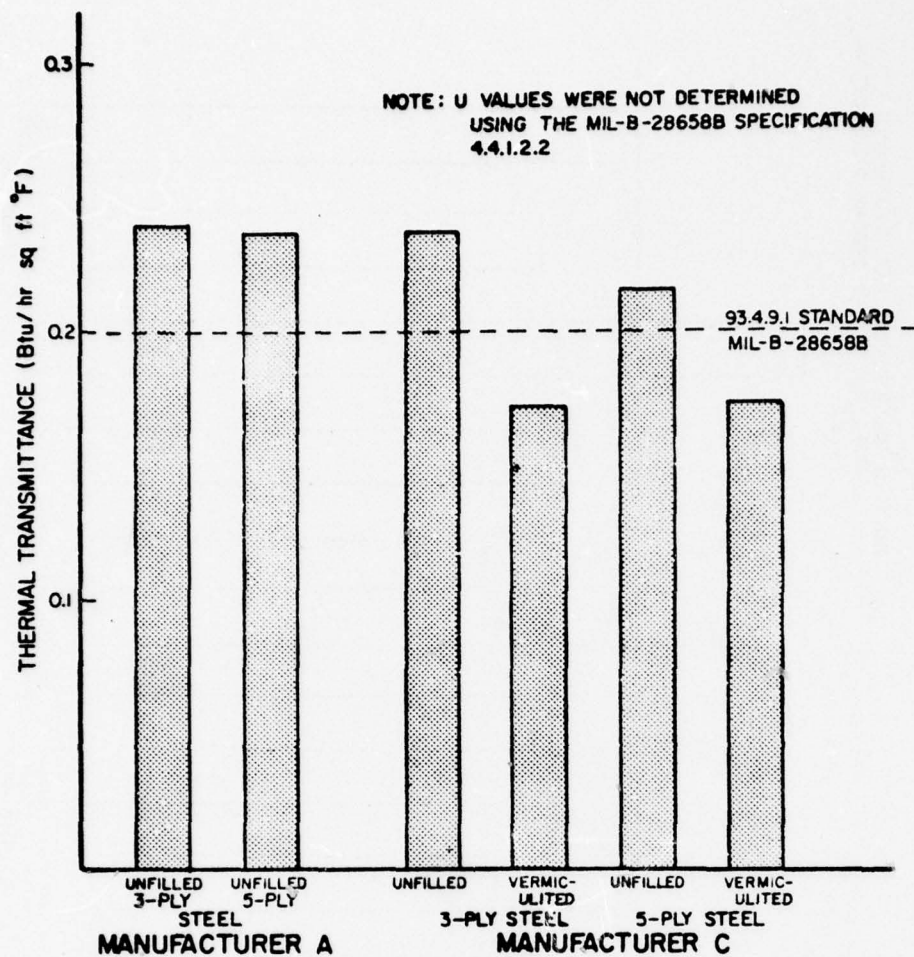

Figure 11. Thermal transmittance values for steel skin panels. Metric conversion factor: 1 Btu/hr sq ft °F = 5.67 W m<sup>2</sup> °K.

ber exposure. After 90 days of tropical chamber exposure at 85°F (29°C) and 96 percent relative humidity, both materials lost about 30 percent of their compressive strength. Loss of strength due to soil burial was even more severe. In addition, in a natural environment, soil contact would make the materials more vulnerable to termites.

Since microbial testing must be conducted in a warm, moist environment, determining how much of the deterioration was due to fungi and how much to moisture was not possible. Since extensive delamination of both manufacturers' materials occurred during the 3-week plate test, moisture may have contributed to loss of compressive strength during tropical chamber

and soil burial testing, although little delamination was actually observed in these tests.

#### Test Results and Design Implications

The addition of a layer of material between the metal skin and honeycomb core significantly increases a panel's resistance to localized superficial damage and its fire endurance time. The five-ply panel did not show significant gains in insulative ability or impact resistance to collisions which do not cause localized damage. The flame spread contributions for three-ply and five-ply panels show that they can be classified as noncombustible materials, but the panels' failure to have any significant fire endurance time limits their application in noncombustible construction.

NOTE: U VALUES WERE NOT DETERMINED  
USING THE MIL-B-28658B SPECIFICATION  
4.4.1.2.2.

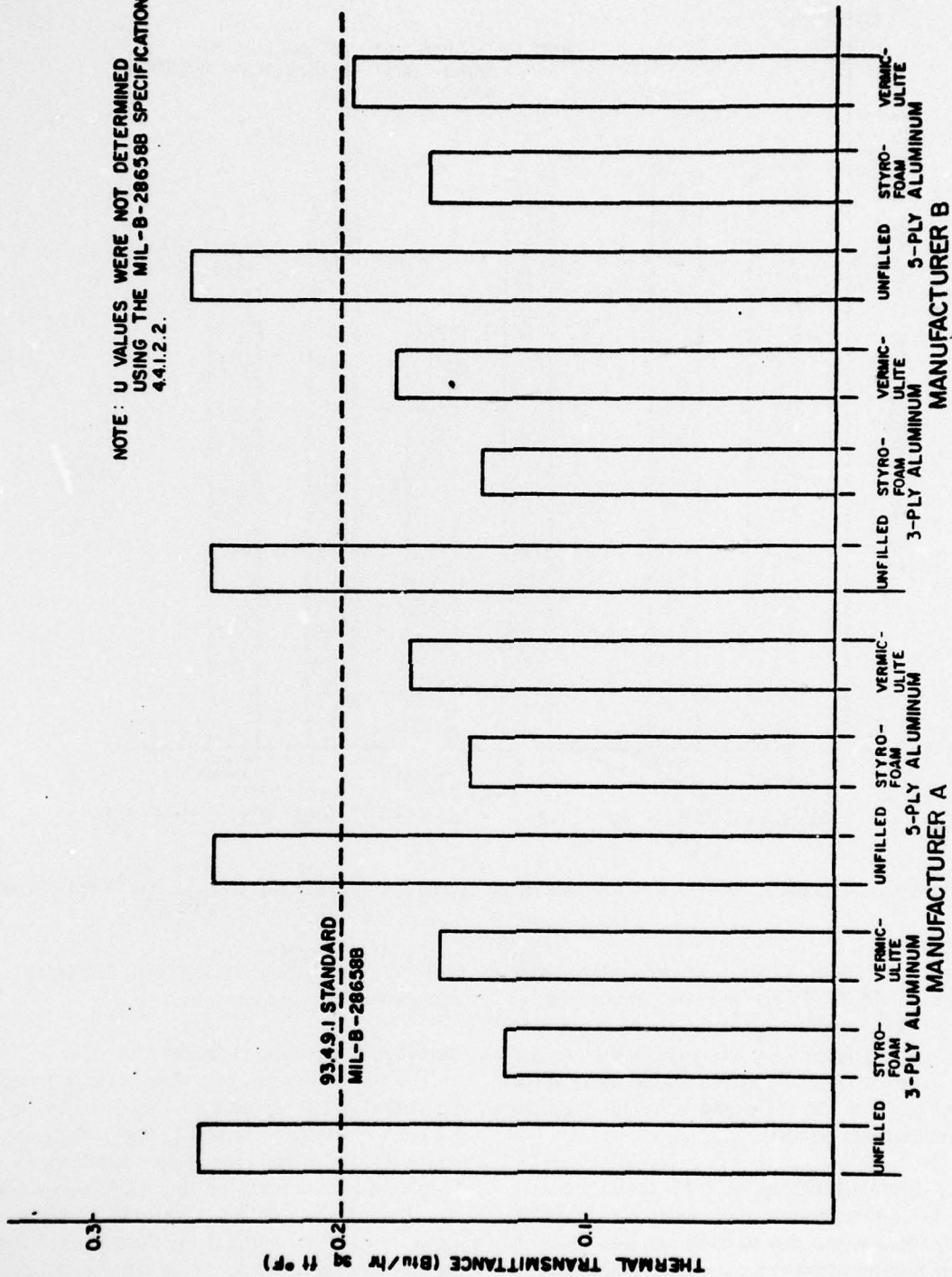

Figure 12. Thermal transmittance values for aluminum skin panels. Metric conversion factor: 1 Btu/hr sq ft °F = 5.67 W m<sup>2</sup> °K.

All but one of the honeycomb core sandwich panels tested for fire endurance as specified by ASTM E-119 failed before the first time-temperature specification on the furnace time-temperature curve. In view of this performance, a minimum property standard for fire endurance times should be analyzed for feasibility as a military specification for relocatable buildings. One such minimum property specification has been adopted by the U.S. Department of Housing and Urban Development (HUD) for single-family dwellings.<sup>17</sup> It requires the following fire endurance times performance for single-family dwellings, as determined by ASTM E-119:

	Minutes
1. Floor systems over crawl space or basement and roofs in detached units . . . .	10
2. Other floor systems . . . . .	20
3. Exterior and bearing walls. . . . .	20
4. Roof in attached units . . . . .	20

For other occupancies, the requirements would be much higher. For instance, for residential occupancies of 20 or more persons, the 1975 *BOCA Basic Building Code*<sup>18</sup> requires a 2-hr fire rating, and the *Uniform Building Code*<sup>19</sup> requires a 1-hr minimum fire rating.

Although the HUD performance requirements can be achieved with common wood stud construction, it is not known at this time whether a honeycomb core sandwich panel exists which, without additional supportive internal material, can obtain the minimum 20-min fire endurance time required for residential use.

Panels developed by industry have been modified to meet the required fire endurance times, but at a cost of panel weight and/or economics. Therefore, the feasibility of using honeycomb core sandwich panels must be reevaluated in terms of the required performance in construction, functional usage, and economics.

Panels without the hardboard ply material have a low threshold of damage. If the panels are expected to experience considerable handling during the assembly

<sup>17</sup>*Minimum Property Standards for Single and Double Family Dwellings* (Department of Housing and Urban Development, 1973), p 4-21.

<sup>18</sup>*BOCA Basic Building Code* (Building Officials and Code Administrators, 1975).

<sup>19</sup>*Uniform Building Code* (International Conference of Building Officials, 1973).

process, the requirement for a five-ply panel should be specified.

## 5 CONCLUSIONS AND RECOMMENDATIONS

### Conclusions

Based on the results of this study, several conclusions can be drawn concerning the performance of load-bearing honeycomb core sandwich panels:

#### Fire Safety

1. Results from the ASTM E-119 test indicate rapid structural collapse of panels in a developed fire.

2. Addition of two 1/8-in. (3.2 mm) plies of hardboard doubled the time before structural collapse, over the three-ply panel; asbestos board plies doubled the time of hardboard plies. However, the maximum time to collapse of 8 min is still quite low compared to conventional wood stud and gypsum board construction.

#### Superficial Damage

1. The addition of a layer of material between the metal exterior skins and the honeycomb core significantly increased the panels' resistance to localized superficial damage (puncture and tears).

2. For buildings with a high incidence of impact from sharp objects, such as barracks, machine shops, kitchens, and warehouses using forklifts, backing the metallic skins with 1/8-in. (3.2 mm) hardboard material or using a thicker gage steel skin will greatly improve the panel's resistance to cosmetic damage.

3. For buildings with a lower incidence of impacts from sharp objects (such as warehouses where things are stored in cardboard boxes, offices, and meeting rooms), where the threshold of superficial damage can be expected to be lower, a three-ply panel can be specified.

4. Where heavy impact is expected, careful attention should be given to establishing peel torque performance at a high level.

#### Thermal Conductivity

Five-ply panels do not afford any advantage in resistance to heat transmission.

### *Durability*

1. Plate test results indicate both manufacturers' panels tested (manufacturers A and B) supported fungal growth with delamination of material.

2. The panels lost 30 percent of their compressive strength after 90 days of the tropical chamber exposure (85°F [29°C] and 96 percent relative humidity).

3. The honeycomb materials evaluated during the tests appear to be vulnerable to the effects of both microbial organisms and insects.

### **Recommendations**

Whenever a building fails in its functional performance or aesthetic appearance, it reflects inadequate planning or construction. Specifications, regulations, safety codes, and standards are among the items used to insure that a minimum amount of risk is involved during the construction and subsequent occupancy of a facility. The scope of this research was limited to determining the level of performance for honeycomb core sandwich panels in the areas of superficial damage, fire safety, durability, and thermal conductivity. To insure that buildings constructed using these panels are safe and satisfactory, the research initiated during this program should be continued. Four areas require further investigation and/or development:

1. The improvement of structural integrity of the panels during a fire.

2. The development and adoption of standard performance levels for superficial damage, structural integrity, durability, and thermal conductivity.

3. Field surveys of other performance problems of honeycomb core sandwich panel facilities.

4. Field tests to predict expected life of the panels. The microbial tests performed in the laboratory cannot be used to predict field-life of the materials; this type of information can be developed only from the experience gained by field trials.

Since the honeycomb materials evaluated appear to be vulnerable to the effects of both microbial organisms and insects, it is recommended that strong consideration be given to the protection of honeycomb materials for shelter usage against fungi and termites. At the very least, the soil around and within the construction area could be treated with a standard soil pesticide such as chlordane to control insect infestation.

### **CITED REFERENCES**

*1970 Annual Book of ASTM Standards* (American Society for Testing and Materials).

*BOCA Basic Building Code* (Building Officials and Code Administrators, 1975).

*Characteristics of Load-Bearing Sandwich Panels for Housing* (Forest Products Laboratory, 1973).

*Military Specification Building Components, Panelized, Prefabricated, Ready-Cut, Relocatable, MIL-B-28658B* (Department of Defense, 1974).

*Minimum Property Standards for Single and Double Family Dwellings* (Department of Housing and Urban Development, 1973).

Lew, H.S., *Impact Test on Gypsum Wallboard* (National Bureau of Standards, 1970).

*National Fire Codes, Vol 9* (National Fire Protection Association, 1975).

Pielert, J.H., T.W. Reichard, and L.W. Masters, *Structural Evaluation of Steel Faced Sandwich Panels* (National Bureau of Standards, 1974).

Reichard, T.W. and E.V. Leyendecker, *Test and Evaluation of the Prefabricated Lewis Building and Its Components*, Report No. NBS-10163 (National Bureau of Standards, 1970).

*Uniform Building Code* (International Conference of Building Officials, 1973).

### **UNCITED REFERENCES**

Eickner, H.W., "Fire Endurance of Wood-Frame and Sandwich Wall Panels," *Journal of Fire and Flammability*, Vol VI (April 1975), pp 155-190.

Son, B.C., *Fire Endurance Test of Steel Sandwich Panels, Exterior Wall and Roof/Ceiling Construction*, Report No. 73-135 (National Bureau of Standards, 1972).

Yancey, C.W. and L.E. Cattaneo, *State-of-the-Art of Structural Test Methods for Walls, Floor, Roofs, and Complete Buildings* (National Bureau of Standards, November 1974).

**APPENDIX A:  
DESCRIPTION OF MANUFACTURERS'  
PANELS**

**Manufacturer A**

**Skins:** 0.027 in. (0.7 mm) aluminum  
Stucco embossed pattern  
Alloy 3003-H154  
Factory painted  
or  
26 gauge steel  
Smooth finish  
ASTM 446 Grade D  
Factory painted

**Core:** 1/2-in. (1.3 cm) cell size  
80-lb (36.3 kg) Kraft paper  
15 percent phenolic resin  
impregnation

**Adhesive:** Contact type, heat reactivated  
adhesion varies with time, starting at  
approximately 1840 psf (88 kN/m<sup>2</sup>)  
within 24 hours of panel manufacture  
and increasing to approximately 2800  
psf (134 kN/m<sup>2</sup>) or more after 30  
days. Adhesion is measured by a  
vertical pull test.

**Backup Panel:** 1/8-in. (3.2 mm) tempered hardboard.

Panels have a flame spread rating of 0 when filled with polystyrene bead insulation.

Panels marked "polystyrene insulation" contain polystyrene beads.

Panels marked "vermiculite insulation" contain vermiculite.

**Manufacturer B:**

**Skins:** .025-in. (0.6 mm) aluminum  
Stucco embossed pattern  
.125-in. (3.2 mm) hardboard

**Core:** 1/2-in. (1.7 cm) cell size  
99 lb (44.9 kg) Kraft honeycomb  
11 percent phenolic resin  
impregnation

**Adhesive:** Bondmaster No. 586-30  
Neoprene, thermosetting

**Insulation  
Material:** Styrofoam pellets  
Moisture-resistant vermiculite

**Manufacturer C:**

**Noncombustible  
Honeycomb:** Core Kraft paper  
80 lb (36.3 kg)/ream paper weight  
26 percent phenolic impregnation by  
weight  
1/2-in. (1.7 cm) cell size  
2.950-in. (7.5 cm) or 2.680-in. (6.8  
cm) core thickness  
Fire hazard classifications better than  
25-25-25 when tested in panel form  
(3-in. [7.6 cm] thick)

**Talon Adhesive:** A heat-reactive (semipolymerizing)  
neoprenephenolic. Consistently a lap-  
tensile-shear-strength (by ASTM D-  
1002) of at least 1250 psi (86.25  
kN/m<sup>2</sup>) when tested on a flat sub-  
strate and at least 1000 psi (6895  
kN/m<sup>2</sup>) when tested with a stucco  
embossed substrate.  
Adhesive does not embrittle with  
cold nor with age and is waterproof  
and is not biodegradable from fungus  
mold or rot.

**Asbestos:** Asbestos Cement Board meets Federal  
Specification SS-B-755, Type F, and  
ASTM Specification C-220, Type F.

**6 ga. Interstate  
Steel Facings:** The painted steel-facings have inner  
surfaces coated with a 0.3 mil min-  
imum thickness "washcoat" primer  
(Jones-Dabney Epoxy #33-3470)  
suitable for adhesive bonding to meet  
adhesive specifications.

**Insulation  
Material:** Vermiculite

## APPENDIX B: PUNCTURE RESISTANCE TEST PROCEDURE

### 1. Scope

This test method covers a procedure for measuring the energy required to puncture a multi-material-ply panel with an object 1/2 in. in diameter. This test is intended only to produce relative values and does not form a basis for a building code or rating.

### 2. Apparatus

2.1. The test apparatus consists of an electro-hydraulic closed loop "Materials Testing System" load machine. The system allows control under a number of modes thereby allowing a wide range of programming for various load environments. The U.S. Army Construction Engineering Research Laboratory has a 50,000-lb (22 680 kg) hydraulic load machine suitable for impact-puncture testing. Figure B1 illustrates a typical test arrangement of the system.

2.2 The bottom head assembly of the hydraulic load machine will consist of a lockjaw arrangement in which the 1/2 in. (1.7 cm) diameter bit is inserted into the jaws and the jaws are locked against the bit, securing it in place. The top head assembly will have a tray mounted to it which will be used to secure a 15 x 15 x 3 in. (37 x 37 x 7.6 cm) test sample, as shown in Figure B2.

2.2. The bits used in the test are labeled A and B. Bit A is a 1/2-in. (1.7 cm) diameter drill rod with an overall length of 5 in. (12.7 cm). One end of the bit is machined down to form a sharp conical point. Bit B is similar to A, but has a round, blunt tip. Figures B2 and B3 show the mounting for the test apparatus.

### 3. Test Specimen

The test specimen size will be 15 x 15 x 3 in. (37 x 37 x 7.6 cm). Specimens will be conditioned to a constant weight by being stored in a laboratory test room for at least 48 hours with a constant temperature and humidity.

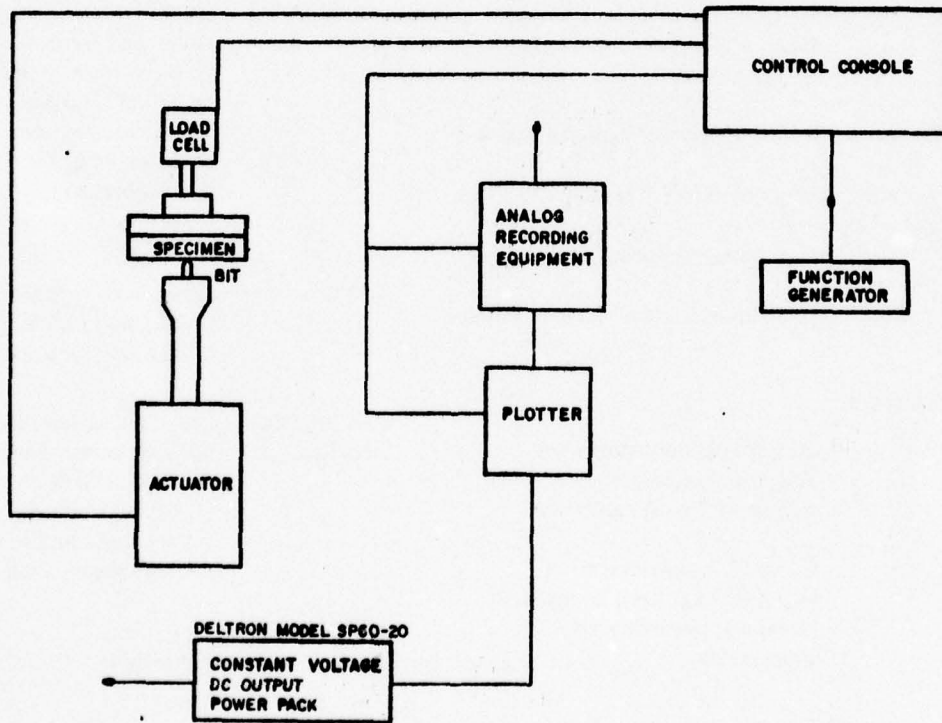

Figure B1. Puncture test arrangement.

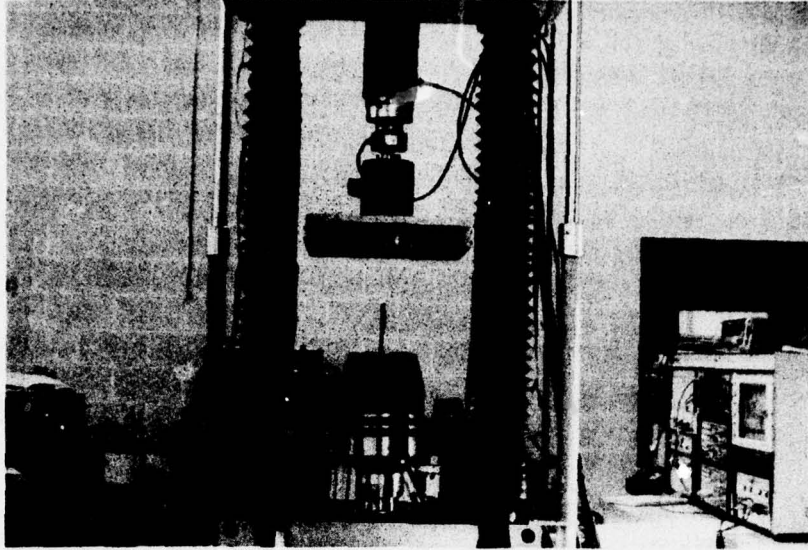

Figure B2. Test apparatus setup with bit type B.

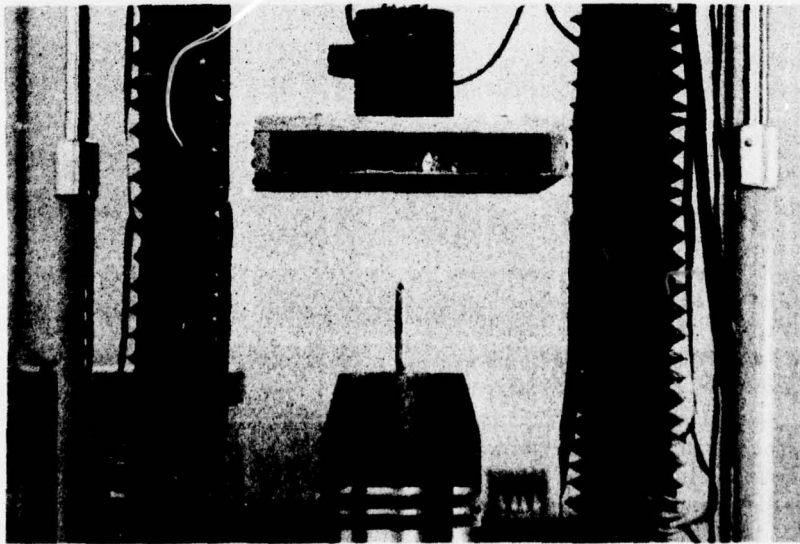

Figure B3. Close-up of test apparatus setup with sharp bit, type A.

#### 4. Procedure

4.1. Warm up the electrical and hydraulic equipment for at least 15 min. Insert bit A into the lock jaws approximately 1 in. (2.54 cm) to insure that the bit will travel completely through the specimen. Raise the bottom actuator until the tip of the bit is 6 in. (15.2 cm) from the bottom of the tray (see Figure B2). Calibrate the horizontal axis of the analog plotter to have 1 in. (2.54 cm) of plot per 1/2 in. (1.7 cm) of stroke. Set the function generator, which programs the actuator stroke, to match the decaying velocity function which produces the curve in Figure B4. The initial velocity is to be 16 in./sec (40.6 cm/sec). Trigger the generator and check the actuator action. Switch the function generator to a half square wave pulse with a period of 2 sec. Set the cross head speed at 2 in./sec (5.1 cm/sec). Trigger the generator and check the actuator stroke to insure that it travels 4 in. (10.2 cm). Switch the function generator back to the decaying velocity pulse.

4.2. Insert the specimen so its edges rest against the edges of the tray. Raise the bit until a preload between 10 and 15 lb (4.5 to 6.8 kg) is obtained. Reset the analog plotter to a baseline of zero and note on the chart the specimen number, date, preload, analog tape reference, and test run number.

4.3. With the analog plotter on, initiate the recording function of the analog recorder, run through a count-down, then trigger the generator. The bit should have traveled completely through the specimen and a plot of the load versus stroke should have been made. Turn the recorder back to standby. Check the resolution of the plot and adjust the gain of the vertical scale to produce a 1/2 to 1 full scale plot on the plot graph. Run the analog recorder on the play mode with the output connected to the analog plotter. This allows a check to be made on the recorder and makes a new plot.

4.4. Loosen the specimen from the bit. Slide the specimen tray holder down to allow the bit to puncture another hole, without any bending or tearing influence from the previous bit (move the specimen over about 2 in. [5.1 cm]). Repeat the procedure in Sections 4.2 and 4.3 until five runs are successfully accomplished. Switch the function generator to the half square wave pulse and repeat the test procedure until five successful runs are recorded. Switch from bit A to bit B and

attempt the same test runs as specified for bit A in Sections 4.2 and 4.3. If difficulty arises in the use of the blunt bit, make a note of the problem in the test log book and continue without finishing the runs.

#### 5. Data Reduction

5.1. Determine the area under the load-stroke curves between 0 and 3.5 in. (0 and 8.9 cm) of stroke. This can be done using a planimeter or integrating technique. Check the accuracy of the areas by repeating the method of area determination and checking the values for a repeatability of 1 percent. Add the product of the preload times 3.5 in. (8.9 cm) to the area. This equals the work done on a panel.

5.2. Record the work required to puncture a panel along with the identification data on forms similar to the one shown in Figure B5. Determine the mean, standard deviation, and coefficient of variation for the five successful test runs and list the values under the comments column.

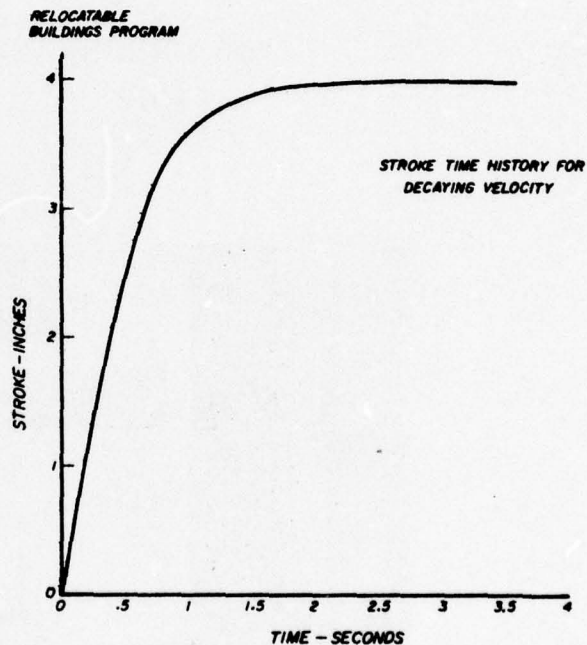

Figure B4. Excitation curve for decaying velocity puncture test. Metric conversion factor: 1 in. = 2.54 cm.



## APPENDIX C: RESISTANCE TO PUNCTURE AND TEAR PROPAGATION TEST PROCEDURE

### 1. Scope

This test method covers a procedure for measuring the dynamic force required to puncture and tear the surface of a multi-ply industrial panel. This information provides a relative indication of the superficial damage resistance of a composite industrial panel.

### 2. Apparatus

Figure C1 shows the test apparatus in a pretest condition. The test apparatus basically consists of a falling mass which is restrained in the horizontal direction and can be held vertically by some triggering mechanism. A sample is mounted by clamps or sheet metal screws to a steel plate which holds the sample at a  $76^\circ \pm 1/2^\circ$  angle from the base (see Figure C2). The weight has a bit rigidly fastened to its side which will tear the test specimen's surface as shown in Figure C2. A close-up photograph of the bits is shown in Figure C3. The test apparatus is constructed of A-36 steel with the exception of the case-hardened 1-in. (2.54 cm) diameter rods and bearings.

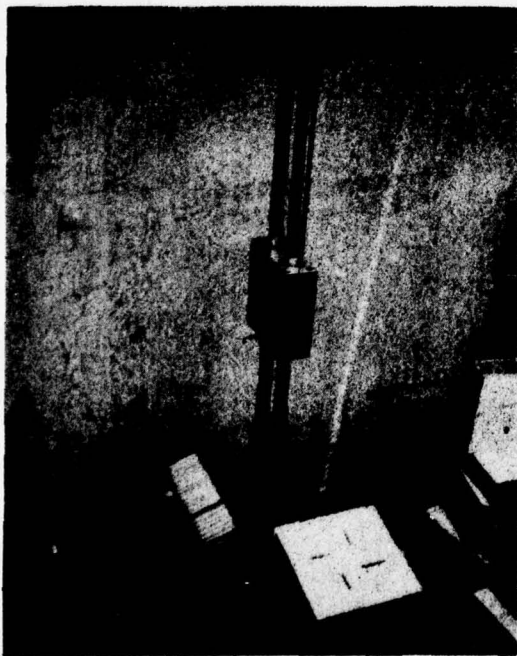

Figure C1. Puncture and tear propagation test apparatus with a  $24.6 \pm .1$  lb ( $11.2 \pm 0.05$  kg) weight.

### 3. Test Specimen

The test specimen will consist of a section of the panel cut to 10 x 10 in. (25.4 x 25.4 cm) by the diameter of the core, usually 3 in. (7.6 cm). Specimens will be stored for at least 48 hours in a laboratory test room having a constant temperature and humidity level.

### 4. Test Procedure

4.1. The carriage, shown in Figure C1, can be removed from the guide rods by removing the steel cap located on top of the rods. Remove the carriage and insert bit A into the mount with the sharp edge pointed down. Weigh the carriage, recording the value on a data sheet (Figure C4). Reinsert the carriage and steel cap on the apparatus. Secure the test specimen on the mounting plate using two clamps on the sides. The base of the specimen should rest on a steel 1/4-in. (6.4 mm) bar.

4.2. Slowly lower the carriage until the bit hits the surface of the specimen. Measure the vertical distance between a selected reference on the base of the apparatus and a reference on the specimen (maintain the same reference points throughout the experiment). This distance is  $h_i$  or the initial height.

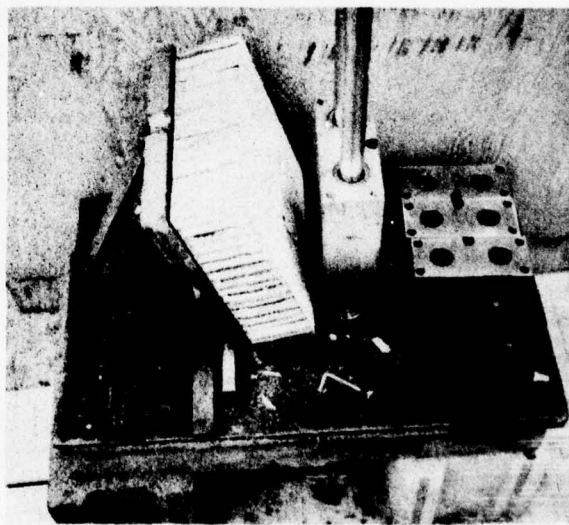

Figure C2. View of the apparatus after tearing the surface of a three-ply panel.

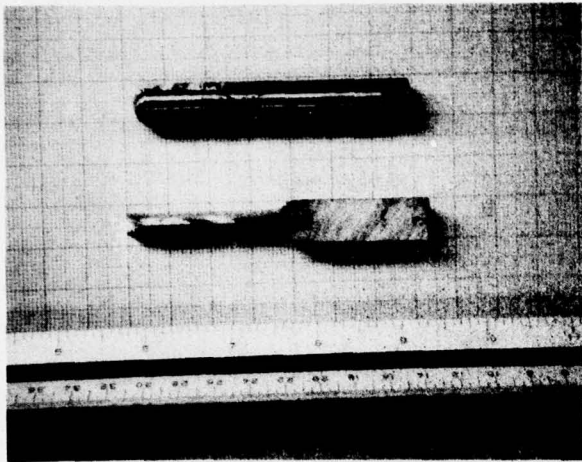

Figure C3. Picture of bits B (upper) and A (lower).

4.3. Raise the carriage to a drop height of 50 cm or the estimated height which will cause a 6- to 12-cm tear on the surface of the panel. Lock the carriage into place by loosening the set screw on the rod which holds the trigger and adjusting the height of the trigger mechanism. Measure the distance between the base and carriage reference,  $H_d$ .

4.4. Trigger the release mechanism and watch the test specimen for possible shifting during the impact; if shifting occurs, reclamp the specimen and repeat the test procedure. Measure the vertical height between the base and carriage reference points,  $H_f$  (final height). Subtract  $H_f$  from  $H_i$  to obtain the tear length. If the tear is between 6 and 12 cm long, continue to test at the  $H_d$  height appropriately. Shift the specimen so

that a new tear on the surface will be made. Repeat the drop test until a drop height is obtained which causes a 6- to 12-cm tear.

4.5. Subtract  $H_f$  from  $H_d$  to obtain the drop height. Record the tear length and drop height on a data sheet like the one shown in Figure C4.

4.6. Repeat the tear procedure (Sections 4.2 through 4.5), until five successful runs have been made, shifting the specimen so that the tears will not be influenced by previous tears.

4.7. Repeat the procedure outlined in Sections 4.1 through 4.6 using bit B instead of bit A.

## 5. Data Reduction

5.1. Reduce the data by determining the tear resistance  $F$  where  $F$  is computed by:<sup>20</sup>

$$F = [(W \times H)/L] + W$$

where  $W$  = Weight of the carriage, kg  
 $H$  = Height of the carriage, mm  
 $L$  = Length of tear, mm.

5.2. Calculate the standard deviation for each set of five runs. Divide the standard deviation by the mean to determine the coefficient of variation.

5.3. Present the mean values of each test set for each manufacturer by illustrating the results in bar chart form. Indicate the coefficient of variation for each set on each bar.

<sup>20</sup>1970 Annual Book of ASTM Standards, ASTM D-2582, p 206.



## APPENDIX D: IMPACT TEST PROCEDURE

### 1. Scope

This test is performed to determine the structural integrity of a bearing wall subjected to impact loading from a deformable body. It is similar to the American Society for Testing and Materials (ASTM) Standard Test No. E-72, *Impact Test—Specimen Vertical*.<sup>21</sup>

### 2. Test Specimen

Tests will be made on 8 x 10 ft (2.4 x 3.0 m) walls consisting of two 3 x 8 ft (0.9 x 2.4 m) outer panel sections and one 4 x 8 ft (1.2 x 2.4 m) inner panel. The panels will be joined together as in field use. If a manufacturer specifies an interior or exterior side on a panel, the wall will have one side of interior sided panels.

### 3. Test Apparatus

3.1. A test apparatus will be constructed to support the test specimen and loading devices as in field use. Figure D1 illustrates a structure of 15-in. (38.1 cm) deep channels in which a test specimen is in place.

3.2. A load on the wall will be applied by hydraulic jacks capable of producing a distributed load of 300 lb/lin ft (446 kg/m). Load cells will be attached to the jacks to indicate the load value being applied to the specimen.

3.3. Wall base and ceiling mounting assemblies will be fastened to steel rectangular tubing at the base of the test apparatus and below the hydraulic jacks.

3.4. A sand bag will be constructed as specified in ASTM Standard E-72, Section 12.2.2, except that the leather will be 10 oz (283 g) rather than 12 oz (340 g) lace.

3.5. Deflection measurements will be taken at the center of the middle panel and 3 ft (0.9 m) below the top of one of the vertical joints between the panels. Figure D2 illustrates the location of targets used to take deflection measurements. Figure D3 is a functional diagram of equipment needed to measure deflections

and loads by use of optic-electronic and load cells. Deflections can be measured by light sensors with a limited field. When a nonreflective (black) target is deflected in front of lighted screens in line with the sensor, the analog output is reduced. A magnetic recording of the amplified analog signal then can be made and replayed for future data reduction.

3.6. The sand bag will be suspended on a 14 ft 1/8 in. (4.3 m) steel cable. The center of mass of the bag will be elevated to the center of the middle panel. The bag will be raised by a cable having a release mechanism at one end (see Figure D1). The release action will be constructed to insure the bag will not sway or rotate as it falls.

### 4. Test Procedure

4.1. Insert the wall into the test fixture by inserting one panel into the bottom base assembly, with another panel inserted next to it. Push the vertical joint strips down the panel joint, locking the panels in place. Insert the third panel, locking it in place with the vertical joint strips. Use jacks to raise the top mounting assembly. Insert the top of the wall under the upper mounting assembly, and lower the jacks until the panels experience a 300 lb/lin ft (446 kg/m) loading. Maintain this load value on the specimen throughout the test.

4.2. Mount the targets onto the back of the wall at the locations specified in Section 3.5, and adjust the field view of the light sensors to insure a linear response between the analog output and the deflection of the targets.

4.3. Measure the vertical distance between a reference point on the leather bag at the vertical center of mass, and the floor. Move the bag back on the pendulum swing until the bag has a drop height of over 6 in. (15.2 cm). Connect the release mechanism to the bag, and lengthen the release mechanism cord until the bag has a drop height of 6 in. (15.2 cm).

4.4. Allow the electronic systems to warm up 15 minutes before starting a test series. In a log book, record the information required to identify a panel, the tape location reference, height of bag drop, test run number, and test specimen number. Leave space for recording observations after a test. Start the test with a countdown beginning as the recorder and plotter are turned on; at zero count release the bag. After impact put the equipment on standby. Check the plots to determine if the calibration level was sufficient; correct

<sup>21</sup> 1970 Annual Book of ASTM Standards, Part 14, pp 397-398.

the calibration scale if necessary. Record the specimen number, test run number, bag drop height, and ceiling on the plot charts.

4.5. Repeat the procedures outlined in Sections 4.3 and 4.4, incrementing the drop height 6 in. (15.2 cm) each test run until the panel joints fail.

4.6. Remove the wall specimen from the test apparatus. Shut down all equipment.

#### 5. Data Reduction

Each test run should be plotted. Illegible plots can be replotted using the analog recorder. Determine the maximum displacement from the pretest baseline on a plot and the peak of the displacement curve. This is the instantaneous deflection. The distance between the baselines before and after impact is set deflection. For each wall specimen, plot a curve of the bag height drop versus the instantaneous deflection and the bag height drop versus the set deflection.

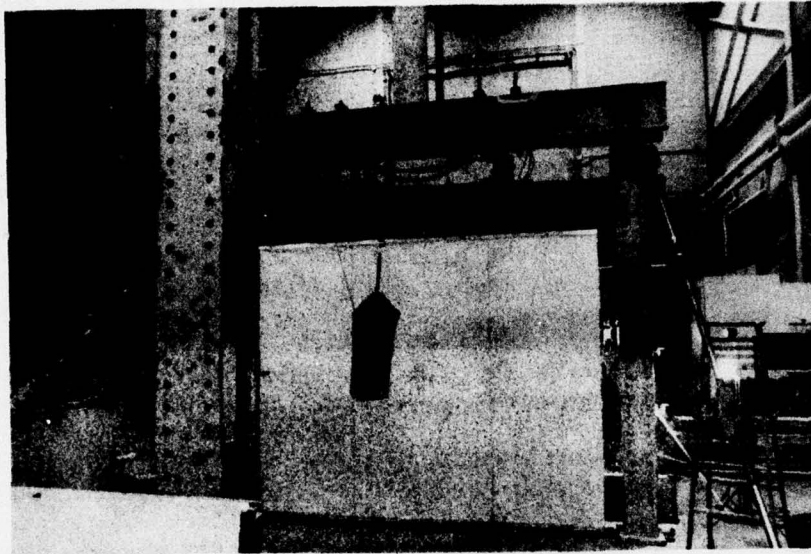

Figure D1. Impact test apparatus.



Figure D2. Deflection targets located on the side of a wall specimen.

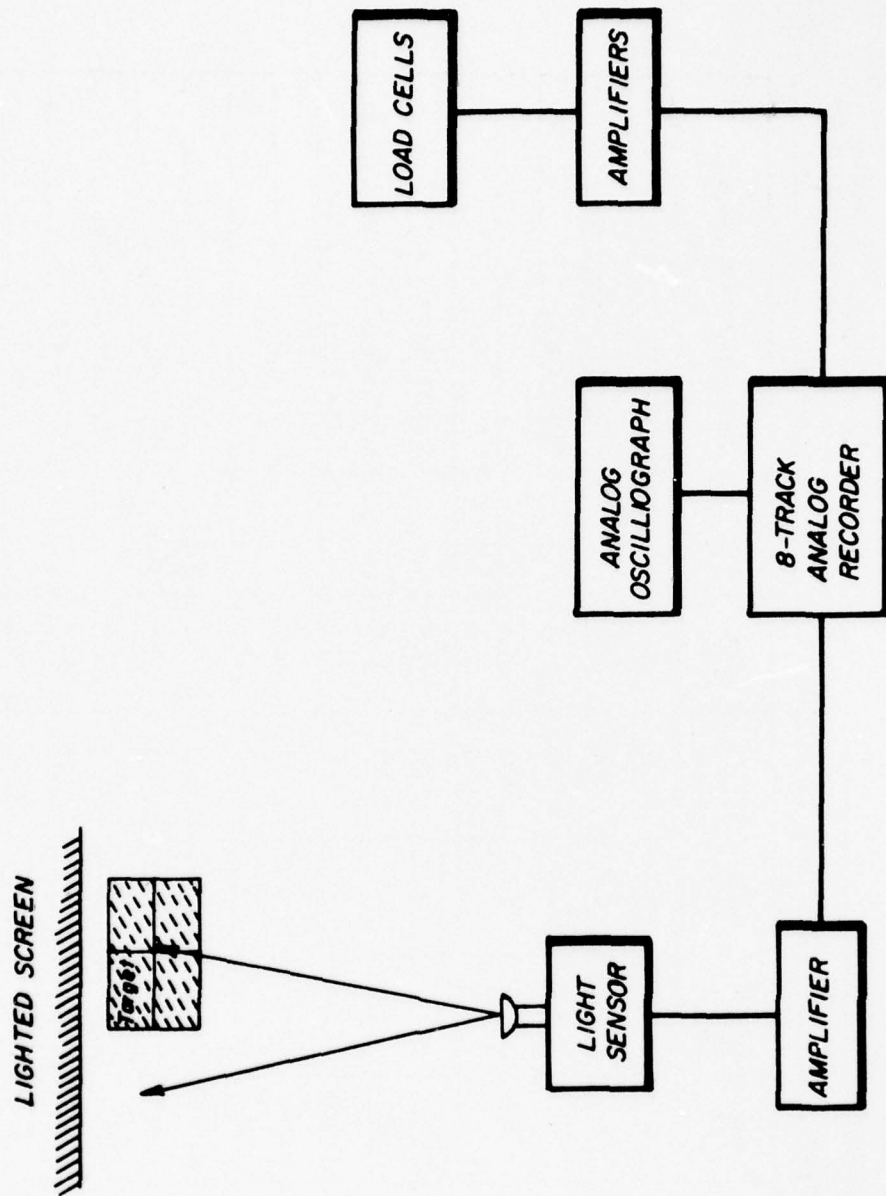

Figure D3. Functional representation of data collection equipment.

APPENDIX E:  
DATA FROM PUNCTURE RESISTANCE TEST

PUNCTURE RESISTANCE TEST

MANUFACTURER: A TEST ENGINEER: B. Mendler  
 PANEL TYPE: 3 Ply Aluminum DATE: 28 Jan 1976 TECHNICIAN: J. Gill

TEST RUN NO.	BIT TYPE	CROSS HEAD SPEED	DWELL PERIOD	TAPE LOCATION REFERENCE	WORK DONE	GRAPH REFERENCE	COMMENTS / VISUAL DAMAGE
1	A	16.0	0.7	0152	16.2		16.5 ft-lbs. = mean
2	A	16.0	0.7	0158	17.1		0.88 = Std. Deviation
3	A	16.0	0.7	0163	15.4		5.3% = C.O.V.
4	A	16.0	0.7	0171	17.3		
5	A	16.0	0.7	0178	-		
6	A	2.0	-	0184	11.6		11.8 ft-lbs. = mean
7	A	2.0	-	0190	11.4		.38 = Std. Deviation
8	A	2.0	-	0201	11.5		3.3% = C.O.V.
9	A	2.0	-	0206	12.35		
10	A	2.0	-	0212	11.9		
11	B	2.0	-	0219	26.7		27.2 ft-lbs. = mean
12	B	2.0	-	0225	28.5		1.08 = Std. Deviation
13	B	2.0	-	0231	39.7		4.0% = C.O.V.
14	B	2.0	-	0238	26.5		
15	B	2.0	-	-	-		

## PUNCTURE RESISTANCE TEST

**MANUFACTURER:** A      **TEST ENGINEER:** B. Wendler  
**PANEL TYPE:** 5 Ply Aluminum      **DATE:** 2 Dec 1975      **TECHNICIAN:** J. Gambill

TEST RUN NO.	BIT TYPE	CROSS HEAD SPEED	DECAY PERIOD	TAPE LOCATION REFERENCE	WORK DONE	GRAPH REFERENCE	COMMENTS / VISUAL DAMAGE
1	A	16.0	0.7	0312	33.6		30.6 ft-lbs. = mean
2	A	16.0	0.7	0318	28.1		1.9 = Std. Deviation
3	A	16.0	0.7	0323	30.9		6.2% = C.O.V.
4	A	16.0	0.7	0328	29.9		
5	A	16.0	0.7	0333	30.5		
6	A	2.0	-	0338	23.5		24.6 ft-lbs. = mean
7	A	2.0	-	0342	26.5		1.4 = Std. Deviation
8	A	2.0	-	0347	25.8		5.8% = C.O.V.
9	A	2.0	-	0351	23.3		
10	A	2.0	-	0356	24.0		
1	B	2.0	-	0431	29.7		31.2 ft-lbs. = mean
2	B	2.0	-	0438	29.5		1.67 = Std. Deviation
3	B	2.0	-	0442	33.6		5.4% = C.O.V.
4	B	2.0	-	0447	31.6		
5	B	2.0	-	0452	31.5		

# PUNCTURE RESISTANCE TEST

MANUFACTURER: A      3 Ply Steel      DATE: 2 Dec 1975      TEST ENGINEER: B. Mendler  
 PANEL TYPE: 3 Ply Steel      J. Gamb111      TECHNICIAN: J. Gamb111

TEST RUN NO.	BIT TYPE	CROSS HEAD SPEED	DECAY PERIOD	TAPE LOCATION REFERENCE	WORK DONE	GRAPH REFERENCE	COMMENTS / VISUAL DAMAGE
1	A	16.0	0.7	0286	26.0		29.2 ft-lbs. = mean
2	A	16.0	0.7	0293	28.4		2.0 = Std. Deviation
3	A	16.0	0.7	0298	30.1		6.9% = C.O.V.
4	A	16.0	0.7	0303	30.4		
5	A	16.0	0.7	0308	31.0		
6	A	2.0	-	0250	24.7		24.0 ft-lbs. = mean
7	A	2.0	-	0261	23.7		.56 = Std. Deviation
8	A	2.0	-	0266	23.8		2.4% = C.O.V.
9	A	2.0	-	0272	24.3		
10	A	2.0	-	0280	23.3		
11	B	2.0	-	0244	54.9		



# PUNCTURE RESISTANCE TEST

**MANUFACTURER:** B      **TEST ENGINEER:** B. Wendler  
**PANEL TYPE:** 3 Ply Aluminum      **DATE:** 10 Dec 1975      **TECHNICIAN:** J. Gill

TEST RUN NO.	BIT TYPE	CROSS HEAD SPEED	DECAY PERIOD	TAPE LOCATION REFERENCE	WORK DONE	GRAPH REFERENCE	COMMENTS / VISUAL DAMAGE
1	A	16.0	0.7		18.0		18.4 = mean
2	A	16.0	0.7		16.8		2.36 ft-lbs. = Std. Dev.
3	A	16.0	0.7		17.0		13% = C.O.V.
4	A	16.0	0.7		-		
5	A	16.0	0.7		21.9		
6	A	2.0	-		12.9		13.5 ft-lbs. = mean
7	A	2.0	-		10.4		2.4 = Std. Dev.
8	A	2.0	-		15.6		17.6% = C.O.V.
9	A	2.0	-		15.1		
10	A	2.0	-		-		
11	B	2.0	-		17.1		17.8 ft-lbs. = mean
12	B	2.0	-		18.5		1.4 = Std. Dev.
13	B	2.0	-		19.4		7.7% = C.O.V.
14	B	2.0	-		16.3		
15	B	2.0	-		-		

# PUNCTURE RESISTANCE TEST

**MANUFACTURER:** B **TEST ENGINEER:** B. Mendler  
**PANEL TYPE:** 5 Ply Aluminum **DATE:** 2 Feb 1976 **TECHNICIAN:** J. Gamb111

TEST RUN NO.	BIT TYPE	CROSS HEAD SPEED	DECAY PERIOD	TAPE LOCATION REFERENCE	WORK DONE	GRAPH REFERENCE	COMMENTS / VISUAL DAMAGE
1	A	16.0	0.7		32.2		33.3 ft-lbs. = mean
2	A	16.0	0.7		34.5		1.6 = Std. Deviation
3	A	16.0	0.7		34.5		4.9% = C.O.V.
4	A	16.0	0.7		34.4		
5	A	16.0	0.7		31.0		
6	A	2.0	-		32.0		30.7 ft-lbs. = mean
7	A	2.0	-		29.5		1.0 = Std. Deviation
8	A	2.0	-		31.0		3.3% = C.O.V.
9	A	2.0	-		30.5		
10	A	2.0	-		-		
11	B	2.0	-		35.7		32.9 ft-lbs. = mean
12	B	2.0	-		31.7		1.7 = Std. Deviation
13	B	2.0	-		31.7		5.1% = C.O.V.
14	B	2.0	-		35.2		
15	B	2.0	-		33.1		

# PUNCTURE RESISTANCE TEST

**MANUFACTURER:** C      **TEST ENGINEER:** B. Mendler  
**PANEL TYPE:** 3 Ply Steel      **DATE:** 10 Feb 1976      **TECHNICIAN:** J. Gambill

TEST RUN NO.	BIT TYPE	CROSS HEAD SPEED	DECAY PERIOD	TAPE LOCATION REFERENCE	WORK DONE	GRAPH REFERENCE	COMMENTS / VISUAL DAMAGE
1	A	16.0	0.7		32.0		32.6 ft-lbs. = mean
2	A	16.0	0.7		31.9		1.2 = Std. Deviation
3	A	16.0	0.7		31.3		3.8% = C.O.V.
4	A	16.0	0.7		33.4		
5	A	16.0	0.7		34.3		
6	A	2.0	-	0926	42.1		36.8 ft-lbs. = mean
7	A	2.0	-	0930	38.7		3.65 = Std. Deviation
8	A	2.0	-	0933	34.5		9.9% = C.O.V.
9	A	2.0	-	0936	35.8		
10	A	2.0	-	0940	32.9		
11	B	2.0	-	0943	36.9		

# PUNCTURE RESISTANCE TEST

**MANUFACTURER:** C **TEST ENGINEER:** B. Wendler  
**PANEL TYPE:** 5 Ply Steel **DATE:** 10 Feb 1976 **TECHNICIAN:** J. Gambill

TEST RUN NO.	BIT TYPE	CROSS HEAD SPEED	DECAY PERIOD	TAPE LOCATION REFERENCE	WORK DONE	GRAPH REFERENCE	COMMENTS / VISUAL DAMAGE
1	A	16.0	0.7		58.5		57.3 ft-lbs. = mean
2	A	16.0	0.7		55.4		1.5 = Std. Deviation
3	A	16.0	0.7		59.1		2.6% = C.O.V.
4	A	16.0	0.7		56.7		
5	A	16.0	0.7		56.5		
6	A	2.0	-	0862	58.2		56.4 ft-lbs. = mean
7	A	2.0	-	0866	58.2		6.4 = Std. Deviation
8	A	2.0	-	0870	64.8		11% = C.O.V.
9	A	2.0	-	0873	53.2		
10	A	2.0	-	0876	47.7		
11	B	2.0	-	0886	101.0		91.7 ft-lbs. = mean
12	B	2.0	-	0893	85.6		6.8 = Std. Deviation
13	B	2.0	-	0896	92.3		7.4% = C.O.V.
14	B	2.0	-	0899	87.9		
15	B	2.0	-	0902	-		

APPENDIX F:  
DATA FROM RESISTANCE TO PUNCTURE AND TEAR PROPAGATION TEST

RESISTANCE TO PUNCTURE - TEAR  
PROPAGATION TEST

MANUFACTURER: A TEST ENGINEER: B. Wendler  
 PANEL TYPE: 3 Ply Aluminum DATE: 10/28/75 TECHNICIAN: J. Gill

TEST SERIES NO.	TEST RUN NO.	BIT TYPE	DROP WEIGHT	LENGTH OF DROP	LENGTH OF TEAR	TEAR RESISTANCE	COMMENTS / VISUAL DAMAGE
1	1	A	24.654	25"	3.59"	196.29#	Mean = 201.2 lbs.
	2	A	24.654	25"	3.58	196.77	Std. Deviation = 4.66 lbs
	3	A	24.654	25"	3.48	201.71	Coef. of Variation = 2.3%
	4	A	24.654	25"	3.43	204.3	
	5	A	24.654	25	3.38	206.96	
2	1	B	24.648	19.125	4.07	140.47	Mean = 135.1 lbs.
	2	B	24.648	19.125	4.57	127.8	Standard Deviation = 4.54 lbs.
	3	B	24.648	18.375	4.07	135.9	Coef. of Variation = 3.4%
	4	B	24.648	18.375	4.07	135.9	
	5	B	24.648	18.375	4.09	135.4	
	6	B	24.648	18.375	4.16		

# RESISTANCE TO PUNCTURE - TEAR PROPAGATION TEST

**MANUFACTURER:** A      **TEST ENGINEER:** B. Wendler  
**PANEL TYPE:** 5 Ply Aluminum      **DATE:** 12-1-75      **TECHNICIAN:** J. Gill

TEST SERIES NO.	TEST RUN NO.	BIT TYPE	DROP WEIGHT	LENGTH OF DROP	LENGTH OF TEAR	TEAR RESISTANCE	COMMENTS / VISUAL DAMAGE
5	1	A	24.654 lbs	24"	2.0"	320.42 lbs	Mean = 354.48 lbs.
	2	A	24.654	30.75	2.125	381.32	Standard Deviation = 28.99 lbs.
	3	A	24.654	30.75	2.50	327.82	Coef. of Variation = 8.2%
	4	A	24.654	30.75	2.125	381.32	
	5	A	24.654	30.75	2.25	361.50	
6	1	B	24.648	23.24	2.09	298.72	Mean = 314.24 lbs.
	2	B	24.648	23.24	1.97	315.42	Standard Deviation = 9.94 lbs.
	3	B	24.648	23.24	1.94	319.92	Coef. of Variation = 3.16%
	4	B	24.648	23.24	2.02	308.22	
	5	B	24.648	23.24	1.89	327.73	
	6	B	24.648	23.24	1.94	315.42	

# RESISTANCE TO PUNCTURE - TEAR PROPAGATION TEST

**MANUFACTURER:** A      **TEST ENGINEER:** B. Wendler  
**PANEL TYPE:** 3 ply Steel      **DATE:** 10/28/75      **TECHNICIAN:** J. Gill

TEST SERIES NO.	TEST RUN NO.	BIT TYPE	DROP WEIGHT	LENGTH OF DROP	LENGTH OF TEAR	TEAR RESISTANCE	COMMENTS / VISUAL DAMAGE
3	1	A	24.654 lbs.	30.0	2.0"	395.6 lbs.	Mean = 313.1 lbs.
	2	A	24.654	30.0	2.7	298.5	Std. Deviation = 46.3 lbs.
	3	A	24.654	30.0	2.8	288.8	Coef. of Variation = 14.8%
	4	A	24.654	30.0	2.8	288.8	
	5	A	24.654	30.0	2.75	293.6	
4	1	B	24.648	19.06	2.64	202.6	Mean = 199.4 lbs.
	2	B	24.648	19.1	2.71	198.0	Standard Deviation = 2.7 lbs.
	3	B	24.648	19.1	2.74	196.1	Coef. of Variation = 1.4%
	4	B	24.648	19.1	2.65	201.9	
	5	B	24.648	19.1	2.70	198.6	

# RESISTANCE TO PUNCTURE - TEAR PROPAGATION TEST

**MANUFACTURER:** A 5 ply steel **TEST ENGINEER:** B. Wendler  
**PANEL TYPE:** 5 ply steel **DATE:** 12-1-76 **TECHNICIAN:** J. Gill

TEST SERIES NO.	TEST RUN NO.	BIT TYPE	DROP WEIGHT	LENGTH OF DROP	LENGTH OF TEAR	TEAR RESISTANCE	COMMENTS / VISUAL DAMAGE
7	1	A	24.654	32	2.23	378.34	Mean = 377.17 lbs.
	2	A	24.654	32	2.28	370.58	Standard Deviation = 6.32 lbs.
	3	A	24.654	32	2.28	370.58	Coef. of Variation = 1.7%
	4	A	24.654	32	2.20	383.16	
	5	A	24.654	32	2.20	383.16	
8	1	B	24.648	23.17	1.91	323.65	Mean = 342.59 lbs.
	2	B	24.648	23.17	1.88	328.42	Standard Deviation = 16.21 lbs.
	3	B	24.648	23.17	1.69	362.57	Coef. of Variation = 4.73%
	4	B	24.648	23.17	1.77	347.3	
	5	B	24.648	23.17	1.75	350.96	

# RESISTANCE TO PUNCTURE-TEAR PROPAGATION TEST

**MANUFACTURER:** B 3 Ply Aluminum **TEST ENGINEER:** B. Wendler  
**PANEL TYPE:** 3 Ply Aluminum **DATE:** 12/10/75 **TECHNICIAN:** J. Gill

TEST SERIES NO.	TEST RUN NO.	BIT TYPE	DROP WEIGHT WEIGHT	LENGTH OF DROP	LENGTH OF TEAR	TEAR RESISTANCE	COMMENTS / VISUAL DAMAGE
1	1	A	24.654	18.438"	3.38	159.14#	Mean = 152.38 lbs.
	2	A	24.654	18.438	3.78	144.91	Std. Deviation = 8.67 lbs.
	3	A	24.654	18.438	3.80	144.28	Coef. of Variation = 5.7%
	4	A	24.654	18.438	3.27	163.67	
	5	A	24.654	18.438	3.63	149.88	
2	1	B	24.648	10.313	2.62	121.67	Mean = 123.78 lbs.
	2	B	24.648	10.313	2.61	122.04	Std. Deviation = 5.48 lbs
	3	B	24.648	10.313	2.69	119.14	Coef. of Variation = 4.4%
	4	B	24.648	10.313	2.34	133.28	
	5	B	24.648	10.313	2.59	122.79	

# RESISTANCE TO PUNCTURE - TEAR PROPAGATION TEST

**MANUFACTURER:** B 5 Ply Aluminum **TEST ENGINEER:** B. Mendler  
**PANEL TYPE:** 5 Ply Aluminum **DATE:** 12-10-75 **TECHNICIAN:** J. Gi'1

TEST SERIES NO.	TEST RUN NO.	BIT TYPE	DROP WEIGHT	LENGTH OF DROP	LENGTH OF TEAR	TEAR RESISTANCE	COMMENTS / VISUAL DAMAGE
3	1	A	24.654	24.312	2.08	312.82	Mean = 309.29 lbs.
	2	A	24.654	24.312	2.09	311.44	Std. Deviation = 3.1 lbs.
	3	A	24.654	24.312	2.11	308.72	Coef. of Variation = 1.0%
	4	A	24.654	24.312	2.11	308.72	
	5	A	24.654	24.312	2.14	304.74	
4	1	B	24.648	24.0"	2.40	271.13	Mean = 264.79 lbs.
	2	B	24.648	24.0	2.41	270.10	Std. Deviation = 8.7 lbs.
	3	B	24.648	24.0	2.39	272.16	Coef. of Variation = 3.3%
	4	B	24.648	24.0	2.57	254.82	
	5	B	24.648	24.0	2.56	255.72	

# RESISTANCE TO PUNCTURE - TEAR PROPAGATION TEST

**MANUFACTURER:** C \_\_\_\_\_ **TEST ENGINEER:** B. Wendler  
**PANEL TYPE:** 3 Ply Steel **DATE:** 1/13/76 **TECHNICIAN:** J. Gill

TEST SERIES NO.	TEST RUN NO.	BIT TYPE	DROP WEIGHT	LENGTH OF DROP	LENGTH OF TEAR	TEAR RESISTANCE	COMMENTS / VISUAL DAMAGE
1	1	A	24.654	22.562"	2.21"	276.35#	Mean = 274.59
	2	A	24.654	22.562	2.22	275.21	Std. Deviation = 4.02
	3	A	24.654	22.562	2.29	267.55	Coef. of Variation = 15%
	4	A	24.654	22.562	2.21	276.35	
	5	A	24.654	22.562	2.20	277.49	
2	1	B	24.648	19.188"	2.72	198.52	Mean = 203.22
	2	B	24.648	19.188	2.75	196.63	Std. Deviation = 7.34
	3	B	24.648	19.188	2.72	198.52	Coef. of Variation = 36%
	4	B	24.648	19.188	2.53	211.58	
	5	B	24.648	19.188	2.54	210.84	

# RESISTANCE TO PUNCTURE - TEAR PROPAGATION TEST

**MANUFACTURER:** C      **TEST ENGINEER:** B. Hendler  
**PANEL TYPE:** 5 Ply Steel      **DATE:** 1/13/76      **TECHNICIAN:** J. Gill

TEST SERIES NO.	TEST RUN NO.	BIT TYPE	DROP WEIGHT	LENGTH OF DROP	LENGTH OF TEAR	TEAR RESISTANCE	COMMENTS / VISUAL DAMAGE
3	1	A	24.654	29.062"	1.99"	384.70#	Mean = 401.65
	2	A	24.654	29.062	1.83	416.18	Std. Deviation = 11.56
	3	A	24.654	29.062	1.92	397.83	Coef. of Variation = 2.9%
	4	A	24.654	29.062	1.89	403.75	
	5	A	24.654	29.062	1.88	405.77	
4	1	B	24.648	28.750	1.92	393.73	Mean = 387.45
	2	B	24.648	28.750	2.00	378.96	Std. Deviation = 8.02
	3	B	24.648	28.750	1.91	395.66	Coef. of Variation = 2.1%
	4	B	24.648	28.750	1.94	389.92	
	5	B	24.648	28.750	2.00	378.96	

**APPENDIX G:  
DATA FROM ADHESIVE FAILURE TEST**

		Climbing Peel Data*						
Specimen No.	Specimen Type	Maximum	Force Minimum	Average	Peel Maximum	Peel Average	Bond Failure	
		lb/in.**	lb/in.	lb/in.	in.-lb/in.**	in.-lb/in.	percent	
Mfr A	1	Tan face, three-ply	31.33	22.67	25.33	10.43	7.50	100
	2	Tan face, three-ply	34.33	20.00	25.50	11.89	7.58	100
	3	Tan face, three-ply	39.00	26.67	32.07	14.17	10.79	100
	4	White face, three-ply	37.67	30.17	31.89	13.52	10.70	100
	5	White face, three-ply	37.33	30.33	32.67	13.36	11.08	100
	Average		35.93	25.97	29.49	12.67	9.53	
Mfr A	6	Cream face, five-ply	26.00	23.33	24.93	7.83	7.31	80
	7	Cream face, five-ply	26.67	22.33	23.16	8.15	6.44	60
	8	Cream face, five-ply	27.33	23.33	24.89	8.48	7.29	90
	9	White face, five-ply	26.50	22.67	24.58	8.07	7.13	80
	10	White face, five-ply	28.17	24.67	26.33	8.89	7.99	90
	Average		26.93	23.27	24.78	8.28	7.23	
Mfr B	11	Three-ply	25.67	20.67	23.09	7.66	6.40	98
	12	Three-ply	21.67	18.00	19.69	5.71	4.74	98
	13	Three-ply	22.33	18.00	20.05	6.03	4.92	98
	14	Three-ply	21.67	18.67	20.31	5.71	5.04	98
	15	Three-ply	24.67	19.00	21.02	7.17	5.39	98
	Average		23.20	18.87	20.83	6.46	5.30	
Mfr B	16	Five-ply	29.67	23.67	26.83	9.61	8.23	95
	17	Five-ply	28.00	22.33	24.47	8.80	7.07	95
	18	Five-ply	29.67	23.33	26.05	9.61	7.84	95
	19	Five-ply	26.33	23.33	25.07	7.98	7.37	95
	20	Five-ply	27.00	22.00	23.83	8.31	6.76	95
	Average		28.13	22.93	25.25	8.86	7.45	
Mfr C	34	Three-ply	32.00	24.67	28.67	10.75	9.12	95
	35	Three-ply	31.67	22.67	27.67	10.59	8.64	95
	36	Three-ply	31.67	26.33	29.33	10.59	9.45	95
	37	Three-ply	31.33	26.00	29.00	10.42	9.29	95
	38	Three-ply	31.67	26.00	29.00	10.59	9.29	95
39	Three-ply	27.00	22.33	25.33	8.31	7.49	95	
	Average		30.89	24.67	28.17	10.21	8.88	

\* The Instron universal testing machine was operated at a head speed of  $1.00 \pm 0.01$  in./in. ( $1.00 \pm 0.01$  cm/cm). Load was recorded on Instron X-Y recorder with average load obtained with load readings from X-Y chart data. Specimens were conditioned for 7 days by exposure to a relative humidity of  $50 \pm 2$  percent, at  $73 \pm 2^\circ$ F.

\*\* Metric conversion factors: 1 lb/in. = 0.18 kg/cm; 1 in.-lb/in. = 14.59 N-m.

Climbing Peel Data\* (Cont'd)

Specimen No.	Specimen Type	Maximum	Force Minimum	Average	Maximum Peel	Average Peel	Bond Failure
		lb/in.**	lb/in.	lb/in.	in.-lb/in.**	in.-lb/in.	percent
40	Three-ply (vermiculite)	40.33	30.00	36.00	14.81	12.70	95
41	"	29.66	24.33	26.66	9.61	8.14	95
42	"	39.67	33.00	35.67	14.49	12.54	95
43	"	42.00	35.00	38.67	15.63	14.00	95
44	"	39.67	29.33	34.67	14.49	12.05	95
45	"	39.33	30.67	35.67	14.33	12.54	95
46	"	41.33	29.00	36.33	15.30	12.86	95
47	"	28.00	22.33	25.00	8.80	7.33	95
48	"	28.00	22.67	25.33	8.80	7.49	95
49	"	38.33	31.33	34.67	13.84	12.05	95
Average		36.63	28.77	32.87	13.01	11.17	
50	Five-ply (asbestos cement board)	46.00	35.00	39.33	17.58	14.33	90
51	"	42.33	34.00	37.00	15.79	13.19	95
52	"	48.67	37.67	42.67	18.88	15.96	95
53	"	54.00	44.00	47.67	21.48	18.40	95
54	"	44.67	36.33	40.67	16.93	14.98	95
55	"	52.00	40.33	45.33	20.51	17.25	95
56	"	56.00	42.00	50.00	22.46	19.53	95
57	"	50.33	40.67	45.33	19.69	17.25	90
Average		49.25	38.75	43.50	19.17	16.36	
58	Five-ply (vermiculite asbestos cement board)	58.67	43.00	50.33	23.76	19.69	95
59	"	48.67	39.33	42.00	18.89	15.63	95
60	"	58.67	42.00	48.00	23.76	18.56	95
61	"	55.00	41.67	46.00	21.97	17.58	95
62	"	61.00	44.00	48.67	24.90	18.88	95
63	"	49.67	39.33	44.00	19.37	16.61	95
64	"	49.33	42.00	45.33	19.21	17.25	95
65	"	49.33	40.67	45.33	19.21	17.25	95
Average		53.79	41.50	46.21	21.38	17.68	

**APPENDIX H:  
RESULTS OF THERMAL CONDUCTIVITY TESTS**

**Thermal Conductivity  
of Various Composite Insulating Panels**

Manufacturer Panel Description	Test Temperature	Composite Density	Panel Thickness	Thermal Conductivity	Apparent Composite Thermal Conductivity
	°F*	lb/cu yd*	in.*	Btu/hr sq ft °F*	Btu/hr sq ft °F*
2A Three-Ply Al w/unfilled core	68	148	3.03	0.251	0.76
2B Three-Ply Al w/unfilled core	68	138	3.04	0.250	0.76
3A Five-Ply Al w/unfilled core	-4	273	3.34	0.246	0.82
3A Five-Ply Al w/unfilled core	68	273	3.34	0.153	0.51
3B Five-Ply Al w/unfilled core	-4	266	3.05	0.256	0.78
3B Five-Ply Al w/unfilled core	68	266	3.05	0.157	0.48
4A Three-Ply Al w/styrofoam fill insulation	68	158	3.04	0.132	0.40
4B Three-Ply Al w/styrofoam fill insulation	68	145	3.04	0.141	0.43
5A Five-Ply Al w/styrofoam fill insulation	68	283	3.30	0.145	0.48
5B Five-Ply Al w/styrofoam fill insulation	68	290	3.05	0.161	0.49
6A Three-Ply Al w/vermiculite fill insulation	68	268	3.04	0.158	0.48
6B Three-Ply Al w/vermiculite fill insulation	68	322	3.03	0.175	0.53
7A Five-Ply Al w/vermiculite fill insulation	68	391	3.31	0.169	0.56
7B Five-Ply Al w/vermiculite fill insulation	68	453	3.05	0.190	0.58
8A Three-Ply Steel w/unfilled core	68	196	3.01	0.242	0.73
8C Three-Ply Steel w/unfilled core	68	251	3.04	0.234	0.71
9A Five-Ply Steel w/unfilled core	-4	285	3.33	0.213	0.71
9A Five-Ply Steel w/unfilled core	68	285	3.33	0.120	0.40
9C Five-Ply Steel w/unfilled core	-4	477	3.14	0.207	0.65
9C Five-Ply Steel w/unfilled core	68	477	3.14	0.121	0.38
12C Three-Ply Steel w/vermiculite filled core	68	320	3.01	0.172	0.52
13C Five-Ply Steel w/vermiculite filled core	68	617	3.08	0.168	0.52

Note: These data are given as apparent composite thermal conductivity. This is not a real value since by definition thermal conductivity is meaningful for homogeneous materials only. It is given here for comparative purposes. The thermal conductance values detail the actual conductance across the given panel.

\*Metric conversion factors:  $(^{\circ}\text{F}-32) 5/9 = ^{\circ}\text{C}$ ;  $1 \text{ lb/cu yd} = 0.59 \text{ kg/m}^3$ ;  $1 \text{ in.} = 2.54 \text{ cm}$ ;  $1 \text{ Btu/hr sq ft } ^{\circ}\text{F} = 5.7 \text{ Wm}^2 \text{ } ^{\circ}\text{K}$ .