

AD-A033 764

NAVAL POSTGRADUATE SCHOOL MONTEREY CALIF
STUDY OF THE CYCLIC PERFORMANCE OF SUBMARINE TYPE LEAD-ACID STO--ETC(U)
SEP 76 J L POKORNY

F/6 10/3

UNCLASSIFIED

NL

1 OF 3
AD
A033764

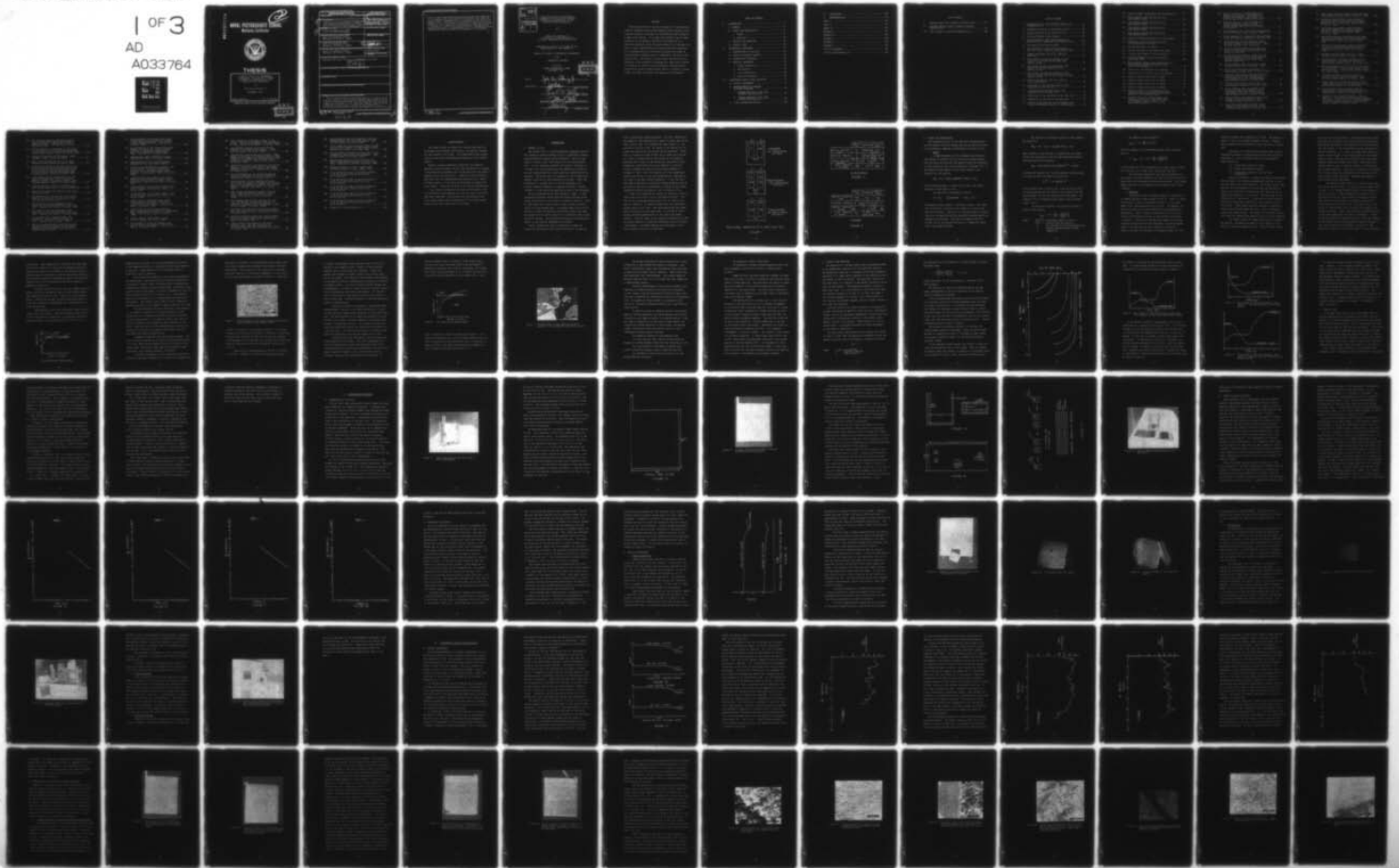

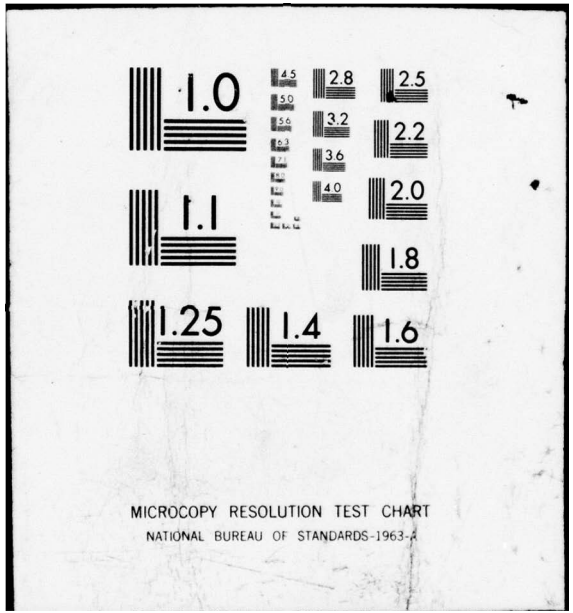

MICROCOPY RESOLUTION TEST CHART
NATIONAL BUREAU OF STANDARDS-1963-A

ADA033764

P
NW

NAVAL POSTGRADUATE SCHOOL
Monterey, California



THESIS

STUDY OF THE CYCLIC PERFORMANCE
OF SUBMARINE TYPE LEAD-ACID STORAGE
BATTERIES BY EXAMINATION OF THE
POSITIVE PLATE STRUCTURES

by

John Louis Pokorny Jr.

September 1976

Thesis Advisor:

A. J. Perkins

Approved for public release; distribution unlimited.

DDC
JL
RECEIVED
DEC 28 1976
REGULATED
D

REPORT DOCUMENTATION PAGE		READ INSTRUCTIONS BEFORE COMPLETING FORM
1. REPORT NUMBER	2. GOVT ACCESSION NO.	3. RECIPIENT'S CATALOG NUMBER
4. TITLE (and Subtitle) Study of the Cyclic Performance of Submarine Type Lead-Acid Storage Batteries by Examination of the Positive Plate Structures,		5. TYPE OF REPORT & PERIOD COVERED Master's Thesis, Mechanical Engineering & Mech. Engineer
7. AUTHOR(s) John Louis/Pokorny, Jr		6. PERFORMING ORG. REPORT NUMBER
9. PERFORMING ORGANIZATION NAME AND ADDRESS Naval Postgraduate School Monterey, California 93940		8. CONTRACT OR GRANT NUMBER(s)
11. CONTROLLING OFFICE NAME AND ADDRESS Naval Postgraduate School Monterey, California 93940		10. PROGRAM ELEMENT, PROJECT, TASK AREA & WORK UNIT NUMBERS
14. MONITORING AGENCY NAME & ADDRESS (if different from Controlling Office) Naval Postgraduate School Monterey, California 93940		12. REPORT DATE Sep 1976
		13. NUMBER OF PAGES 260
		15. SECURITY CLASS. (of this report) Unclassified
		15a. DECLASSIFICATION/DOWNGRADING SCHEDULE
16. DISTRIBUTION STATEMENT (of this Report) Approved for public release; distribution unlimited. 12 259p.		
17. DISTRIBUTION STATEMENT (of the abstract entered in Block 20, if different from Report)		
18. SUPPLEMENTARY NOTES		
19. KEY WORDS (Continue on reverse side if necessary and identify by block number)		
20. ABSTRACT (Continue on reverse side if necessary and identify by block number) The microstructures of the active material of the positive plate of submarine type storage batteries were studied, using scanning electron microscopy, as the batteries were cycled on a deep cycle routine. It is seen that capacity loss of these batteries can be directly related to the formation of a coralloid structure within the active material of the positive		

251450

JP

plate in both lead-antimony and lead-calcium grid batteries. It is proposed that this coralloid structure also leads to active material shedding which is observed at the end of the battery life. The ability of thick plate lead-calcium grid batteries to be successfully operated on a deep cycle routine is related to a reserve of active material retained within the positive plate as lead-sulfate, which is eventually transformed into PbO_2 to maintain the capacity of the battery.

DD Form 1473
1 Jan 73
S/N 0102-014-6601

ACCESSION for	
NTIS	White Section <input checked="" type="checkbox"/>
DDC	Diff Section <input type="checkbox"/>
UNANNOUNCED	<input type="checkbox"/>
JUSTIFICATION	
BY	
DISTRIBUTION/AVAILABILITY CODE	
Dist.	AVAIL. CODE/SPECIAL
A	

Study of the Cyclic Performance
of Submarine Type Lead-Acid Storage
Batteries by Examination of the
Positive Plate Structures

by

John Louis Pokorny Jr.
Lieutenant, United States Navy
B.S.E.E., Marquette University, 1969

Submitted in partial fulfillment of the
requirements for the degrees of

MASTER OF SCIENCE IN MECHANICAL ENGINEERING

and

MECHANICAL ENGINEER

from the
NAVAL POSTGRADUATE SCHOOL
September 1976

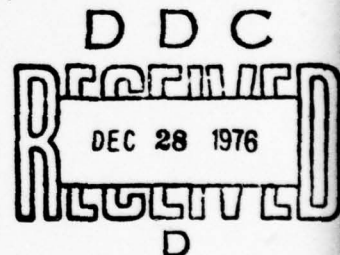

Author

John Louis Pokorny Jr.

Approved by:

Jeff Perkins

Thesis Advisor

Larry R. McVicker

Second Reader

Allen E. Fuchs

Chairman, Department of Mechanical Engineering

J. B. ...

Academic Dean

ABSTRACT

The microstructures of the active material of the positive plate of submarine type storage batteries were studied, using scanning electron microscopy, as the batteries were cycled on a deep cycle routine. It is seen that capacity loss of these batteries can be directly related to the formation of a coralloid structure within the active material of the positive plate in both lead-antimony and lead-calcium grid batteries. It is proposed that this coralloid structure also leads to active material shedding which is observed at the end of the battery life. The ability of thick plate lead-calcium grid batteries to be successfully operated on a deep cycle routine is related to a reserve of active material retained within the positive plate as lead-sulfate, which is eventually transformed into PbO_2 to maintain the capacity of the battery.

TABLE OF CONTENTS

I.	INTRODUCTION - - - - -	17
	A. GENERAL - - - - -	17
	B. THEORY AND CONSTRUCTION - - - - -	21
	1. Theory - - - - -	21
	2. Materials - - - - -	23
	C. CAPACITY AND OPERATION - - - - -	34
	D. CAPACITY LOSS - - - - -	39
II.	EXPERIMENTAL PROCEDURES - - - - -	43
	A. CONSTRUCTION OF THE CELLS - - - - -	43
	B. CAPACITY RATING OF BATTERY - - - - -	52
	C. OPERATION OF BATTERIES - - - - -	58
	D. ANALYSIS PROCEDURES - - - - -	60
	1. Sample Preparation - - - - -	60
	2. SEM Analysis - - - - -	66
	3. X-ray Diffraction - - - - -	69
	4. Optical Microscopy - - - - -	69
III.	EXPERIMENTAL RESULTS AND DISCUSSION - - - - -	72
	A. BATTERY PERFORMANCE - - - - -	72
	B. OBSERVATIONS WITH SCANNING ELECTRON MICROSCOPY - - - - -	82
	1. Changes Observed in the Lead- Antimony Type Batteries - - - - -	82
	2. Changes Observed in the Lead- Calcium Type Batteries - - - - -	126
	C. X-RAY DIFFRACTION ANALYSIS - - - - -	168

IV. CONCLUSIONS	175
V. RECOMMENDATIONS	177
TABLE I	179
TABLE II	179
TABLE III	180
APPENDIX A	181
APPENDIX B	184
APPENDIX C	198
APPENDIX D	223
APPENDIX E	248
LIST OF REFERENCES	257
INITIAL DISTRIBUTION LIST	260

LIST OF TABLES

I. Maximum impurities allowed in battery water - - - 179

II. Maximum impurity levels allowed in battery
sulfuric acid - - - - - 179

III. TVG voltages at specified temperatures - - - - - 180

LIST OF FIGURES

1.	Representation of the discharge reaction in a lead-acid cell - - - - -	19
2.	Discharge reactions of the lead-acid cell - - - - -	20
3.	Charge reactions of the lead-acid cell - - - - -	20
4.	The Lead-Antimony Phase Diagram - - - - -	26
5.	Microstructure of the lead-antimony grid material from a submarine type battery plate - - -	28
6.	The Lead-Calcium Phase Diagram - - - - -	30
7.	Microstructure of the lead-calcium grid material from a submarine type battery plate - - -	31
8.	Typical discharge curves for lead-acid batteries - - - - -	36
9.	The current vs time and voltage vs time plots of a constant current step type battery charge - - - - -	37
10.	The current vs time and voltage vs time plots of a constant potential type battery charge - - - - -	38
11.	The current vs time and voltage vs time plots of a modified constant potential type battery charge - - - - -	38
12.	View of the typical test cell used in this investigation - - - - -	44
13.	Dimensions of the typical battery plate size used in the test cells - - - - -	46
14.	A typical positive plate used in the construction of the test cells - - - - -	47
15.	Dimensions of the container of the test cells - - -	49
16.	Dimensions of the tops of the test cells - - - - -	49
17.	Battery connections and bus arrangement with view of the terminal board of a test battery - - -	50

18.	Typical element construction of the test cells - -	51
19.	Time versus current log-log plot for test battery PbSb#1 - - - - -	54
20.	Time versus current log-log plot for test battery PbSb#2 - - - - -	55
21.	Time versus current log-log plot for test battery PbCa#1 - - - - -	56
22.	Time versus current log-log plot for test battery PbCa#2 - - - - -	57
23.	Typical discharge recording of a test battery - - -	61
24.	Removal of a section of battery plate for preparation of samples - - - - -	63
25.	The notched razor cut sample - - - - -	64
26.	The two surfaces of the separation sample - - - - -	65
27.	Fracture type sample of active material - - - - -	67
28.	Cambridge Mode S4-10 scanning electron microscope (SEM) - - - - -	68
29.	Norelco water cooled X-ray diffraction unit, Wide Range Goniometer and Norelco Data Control and Processor - - - - -	70
30.	Curves of a limiting cell on discharge - - - - -	74
31.	Curves of a non limiting cell on discharge - - - - -	74
32.	Capacity versus cycle plot of PbSb#1 - - - - -	76
33.	Capacity versus cycle plot of PbSb#2 - - - - -	78
34.	Capacity versus cycle plot of PbCa#1 - - - - -	79
35.	Capacity versus cycle plot of PbCa#2 - - - - -	81
36.	Positive plate of a lead-antimony grid battery at zero cycles showing the smooth texture of the uncycled plate - - - - -	83
37.	Positive plate of a lead-antimony grid battery at 40 cycles. The first signs of a change in the structure of the plate have occurred - - - - -	84

38.	Positive plate of a lead-antimony grid battery at 50 cycles. The dome-like bulges are evident at the surface. The grid failure of this plate can be seen	- - - - -	86
39.	Positive plate of a lead-antimony grid battery after 60 cycles. A crack exists through approximately 80 percent of the plate	- - - - -	87
40.	Active material of a zero cycle lead-antimony grid alloy battery near the grid, 1200X	- - - - -	89
41.	Active material of a zero cycle lead-antimony alloy grid battery attached to the grid, 230X	- - -	90
42.	Corrosion layer at the interface between the active material and the grid of a lead-antimony battery, 280X, zero cycle	- - - - -	91
43.	Optical photomicrograph of the corrosion layer of a zero cycle lead-antimony type positive plate 400X	- - - - -	92
44.	Corrosion-active material interface with partial separation of the active material from the corrosion layer. 2400X lead-antimony type plate	- - - - -	93
45.	Active material near the grid of a lead-antimony battery after 10 cycles, 1250X	- - - - -	94
46.	The grid-corrosion-active material of a lead-antimony battery after 10 cycles, 625X	- - - -	95
47.	Corrosion layer-active material interface showing the liquid-like entrapment of active material in the surface material. Lead-antimony battery, 10 cycles, 2600X	- - - - -	97
48.	Surface within the corrosion layer of a lead-antimony battery at 10 cycles, 2300X	- - - - -	98
49.	Active material near the center of the pellet with the first stages of void development within the active material. Lead-antimony battery 20 cycles, 2400X	- - - - -	100
50.	Active material near the grid with little change in its microstructure. Lead-antimony battery 20 cycles, 1280X	- - - - -	101
51.	Large scale coralloid structure at the interior of the positive plate. Lead-antimony battery PbSb#1, 35 cycles, 245X	- - - - -	103

52.	Small scale coralloid structure near the grid, lead-antimony battery PbSb#1, 35 cycles, 1200X	- - 104
53.	Corrosion layer surface; note the lack of the spiny needle-like crystals reported in battery life. Lead-antimony battery PbSb#1, 35 cycles, 6000X	- - - - - 106
54.	Corrosion layer surface; note the lack of the spiny needle-like crystals reported earlier. Lead-antimony battery PbSb#1, 35 cycles, 2400X	- - - - - 107
55.	Grid-active material interface in which the corrosion layer measures an average of 60 μ m. Lead-antimony battery, 35 cycles, PbSb#1, 240X	- - - - - 108
56.	Surface of the enlarged coralloid structure at the grid surface with repeated cycling. Lead-antimony battery PbSb#1, 45 cycles, 1100X	- - - - - 110
57.	Enlarged coralloid near the grid. Lead- antimony battery PbSb#1, 45 cycles, 1100X	- - - - - 111
58.	Active material coralloid structure on the undersurface of the dome-like structure. Lead-antimony battery PbSb#1, 45 cycles, 210X	- - - 112
59.	Beginning formation of the coralloid structure by the forming of voids at the center of the active material. Lead-antimony battery PbSb#2, 40 cycles, 1200X	- - - - - 113
60.	The voids forming as the first stage of formation of the coralloid network. Lead- antimony battery PbSb#2, 40 cycles, 1200X	- - - - - 114
61.	Active material near the grid shows little change from that at earlier stages of cycling. Lead-antimony PbSb#2, 40 cycles, 2400X	- - - - - 116
62.	Active material near the grid; note the appearance of the large agglomerates of PbO. Lead-antimony, PbSb#2, 40 cycles, 2350X	- - - - - 117
63.	Interface of grid-corrosion layer - active material. The corrosion layer measures about 27 μ m thick. Note lack of liquid-like entrapment of active material interface. Lead-antimony battery, PbSb#2, 50 cycles, 1400X	- - - - - 118

64.	The corrosion layer at the grid; note the lack of the spiny needle-like crystal observed earlier. Lead-antimony, PbSb#2, 50 cycles, 1250X	- - - - -	119
65.	Active material at the center of the pellet in the transition to the coralloid structure. Lead-antimony battery PbSb#2, 50 cycles, 240X	- - -	120
66.	Surface of the coralloid structure. Lead-antimony, PbSb#2, 50 cycles, 2500X	- - - - -	121
67.	Small coralloid near the grid on a lead-antimony battery PbSb#2, 60 cycles, 2500X	- - - - -	123
68.	Coralloid structure on the left side of the grid failure with some encapsulation of the coralloid due to the lack of current paths to this material causing undercharge lead-antimony battery, PbSb#2, 60 cycles, 240X	- - - - -	124
69.	Lead sulfate partial encapsulation of the coralloid system due to lack of current density reaching this area on charge. Lead-antimony battery, PbSb#2, 60 cycles, 1200X	- - - - -	125
70.	Uncycled positive plate of a lead-calcium grid alloy battery used in the test batteries	- - -	128
71.	Lead-calcium grid alloy positive plate after 60 cycles of test	- - - - -	129
72.	Representation of the bonding of the active material to the grid of a zero cycle lead-calcium type positive plate	- - - - -	130
73.	The clear grid surface observed by the separation of the active material from the grid. Lead-calcium, PbCa#1, 0 cycles, 1200X	- - -	131
74.	The clear grid surface observed by the separation of the active material from the grid. Lead-calcium, PbCa#1, 0 cycles, 6000X	- - -	132
75.	No corrosion layer present between the boundary of the active material and the grid. Lead-calcium, 0 cycles, 1300X	- - - - -	133
76.	Optical microscope photo confirming that no corrosion layer was present at the boundary between the active material and the grid. Lead-calcium, 0 cycles	- - - - -	134

77.	Active material of the zero cycle lead-calcium type positive plate as a uniform closely packed structure. Lead-calcium 0 cycles, 1200X - - - - -	135
78.	Active material of the lead-calcium plate showing its makeup as a closely packed grouping of spheroidal agglomerate of PbO ₂ . Lead-calcium, 0 cycles, 2400X - - - - -	136
79.	Lead-sulfate layer attached to the grid. Lead-calcium, PbCa#1, 10 cycles, 1100X - - - - -	139
80.	Representation of the reserve mechanism observed to take place within PbCa#1 - - - - -	140
81.	Partially transformed lead-sulfate at the grid surface. The spiny needle-like crystals are in evidence around those crystals. Lead-calcium, PbCa#1, 10 cycles, 5500X - - - - -	141
82.	Lead-sulfate at the center of the active material closely packed to form a solid hard center. Lead-calcium PbCa#1, 10 cycles, 2450X - - - - -	142
83.	Active material of the outer layers of the positive plate. Lead-calcium, PbCa#1, 10 cycles, 625X - - - - -	143
84.	Active material of the outer layers of the positive plate. Lead-calcium, PbCa#1, 10 cycles, 2450X - - - - -	144
85.	Center layer of compacted lead-sulfate crystals which was found in the thick plate lead-calcium battery. Lead-calcium PbCa#1, 20 cycles, 1300X - - - - -	146
86.	Center layer of lead-sulfate observed. Note the appearance of partially encapsulated PbO ₂ . Lead-calcium, PbCa#1, 20 cycles, 2750X - - - - -	147
87.	Center layer of lead-sulfate. Lead-calcium, PbCa#1, 20 cycles, 1200X - - - - -	148
88.	Active material which was bonded to the grid at the top and bottom. Lead-calcium, PbCa#1, 20 cycles, 1300X - - - - -	149

89. Active material in the outer layers of the plate. Note the enlargement of the agglomerate of PbO_2 . Lead-calcium, PbCa#1, 20 cycles, 1200X - - 150
90. Lead-sulfate crystals at the grid surface covered by the needle-like crystals. Lead-calcium, PbCa#1, 20 cycles, 5400X - - - - - 151
91. Lead-sulfate covering the grid surface. These appear to have been in a greater state of transformation as evidenced by the spaces that exist between the crystals. Lead-calcium, PbCa#1, 40 cycles, 1275X - - - - - 152
92. Lead-sulfate layer at the center of the active material. Note the appearance of the spaces between these crystals. Lead-calcium, PbCa#1, 40 cycles, 1150X - - - - - 153
93. Early development of the coralloid near the surface of the plate in the active material. Lead-calcium, PbCa#1, 40 cycles, 240X - - - - - 155
94. Active material at the interface with the grid. Note the ordered arrangement and development of voids beginning to form in this active material. Lead-calcium, PbCa#1, 40 cycles, 2500X - - - - - 156
95. Area between lead-sulfate crystals near the grid. Note the dendritic crystals in these areas. Lead-calcium, PbCa#1, 40 cycles, 12700X - - - - - 157
96. Area between lead-sulfate crystals near the grid. The dendritic crystals are seen as increasing in number as cycling proceeds. Lead-calcium, PbCa#1, 60 cycles, 12500X - - - - - 158
97. Coralloid structure within the active material near the grid interface. Lead-calcium, PbCa#1, 50 cycles, 660X - - - - - 160
98. Coralloid structure within the active material near the surface of the photo. Lead-calcium, PbCa#1, 50 cycles, 260X - - - - - 161
99. Lead-sulfate at the center of the active material. This layer has now begun its transformation into PbO_2 . Lead-calcium, PbCa#1, 50 cycles, 1300X - - - - - 162

100.	Lead-sulfate at the grid interface; note the transformation which has taken place. Lead-calcium, PbCa#1, 50 cycles, 2200X - - - - -	163
101.	Fully formed coralloid structure found throughout the active material of the positive plate. Lead-calcium, PbCa#1, 60 cycles, 295X - - - - -	164
102.	Active material at center of plate with little evidence of lead-sulfate being present. Lead-calcium, PbCa#1, 60 cycles, 2500X - - - - -	166
103.	Lead-sulfate was still found to exist in a highly transformed state near the grid interface. Lead-calcium, PbCa#1, 60 cycles, 2100X - -	167
104.	Relative intensity vs 2θ for major X-ray diffraction peaks of αPbO_2 , βPbO_2 , PbSO_4 - - - - -	169
105.	X-ray diffraction plot of relative intensity vs 2θ for 0 cycle PbSb positive plate active material - - - - -	170
106.	X-ray diffraction plot of relative intensity vs 2θ for 0 cycle PbCa positive plate active material - - - - -	171
107.	X-ray diffraction plot of relative intensity vs 2θ for 60 cycle PbSb positive plate active material - - - - -	172
108.	X-ray diffraction plot of relative intensity vs 2θ for 40 cycle PbCa positive plate active material - - - - -	173
109.	X-ray diffraction plot of relative intensity vs 2θ for 60 cycle PbCa positive plate active material - - - - -	174
110.	Schematic of the discharge unit - - - - -	183

ACKNOWLEDGEMENT

The author wishes to express his sincere gratitude for assistance from Professor Jeff Perkins, as advisor, throughout the course of this study. His understanding and counsel have more than once straightened the course of this investigation.

Material Science Laboratory Technician, Roy Edwards, deserves a word of thanks for his untiring devotion to upkeep of the microscopy equipment and his patience with the author's demands on his time and skills. Thanks are also extended to Mike Coyle for his understanding and help during all phases of these studies. He has been an invaluable colleague and true friend. I wish him the best in his future undertakings.

A very special thanks must go to my wife, Barbara, without whose help, encouragement and love this thesis would not have been completed. Her patience and understanding with me as these studies were conducted was of invaluable importance to the final completion of this work.

I. INTRODUCTION

A. GENERAL [1,2,3]

The voltaic cell is an electrochemical apparatus used for the storage of chemical energy, which is converted to direct current electrical energy during discharge. There are two types of voltaic cells, the primary cell and the secondary cell. For all practical purposes the chemical reactions in a primary cell are irreversible: the generation of electric current consumes materials which cannot be replenished by recharging. The second cell or storage cell uses a reversible chemical reaction for the production of current. After the discharge of a storage cell, it can be restored to its original chemical condition by passing an electric current through it in the direction opposite to that of the discharge.

Volta discovered the galvanic battery in 1800. In 1802 Gautherat discovered current passing through platinum wires causes polarization of the wires in a water-filled cell. Then in 1803 Ritter built small piles of metal plates with moist layers of cloth between them. He charged these piles with an electric current and obtained a discharge current from them. He thought he had a device similar to a capacitor which stored electrical energy. Volta proved him wrong and attributed the effect to the chemical decomposition of water.

Plante' entered the scene in 1859 when he began his studies of electrolytic polarization at age 26. He was the

first to devise the lead acid battery. His cell consisted of two sheets of lead separated by a sheet of rubber then rolled into a spiral form. This element was then placed in a 10% solution of sulfuric acid. He showed it was possible to increase the capacity by the process called formation. Formation, as it applies to the Plante' cells, means the creation of a layer of sponge lead on the surface of the negative electrode and a layer of lead dioxide on the positive electrode, which constitutes the active materials of the cell. Plante' presented his battery to the French Academy of Sciences in 1860. The first battery had little usefulness outside the lab due to the long charge period, sometimes up to a year, using many primary batteries. It was not until 1873, when he obtained a hand-driven Gramme generator, that he was able to show the transformation of energy of the system (mechanical-electrical-chemical) and its reversibility.

In 1881 Faure patented the process of applying a paste of lead oxides and sulfuric acid to the positive plate. This type of cell possessed marked superiority in capacity and ease of formation. An American named Buch also developed a pasted plate at this time. Both men experienced poor adherence of the paste to the lead plate. At the end of 1881 a German, Volckmer, punched holes in the lead plate before pasting. From this idea, a grid network to mechanically hold the active material in place was developed by many different investigators. Different designs were developed, of which only a handful are still in use today.

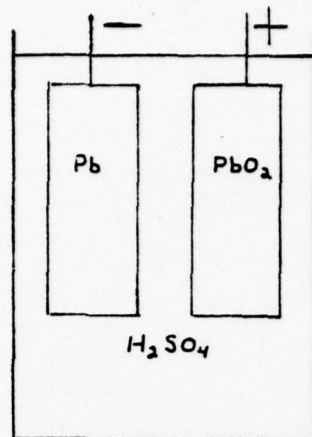

CHARGED
 1.275 SPECIFIC GRAVITY
 2.10 VOLTS

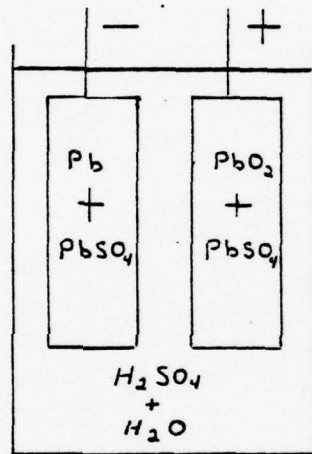

DISCHARGING
 1.200 SPECIFIC GRAVITY
 1.94 VOLTS

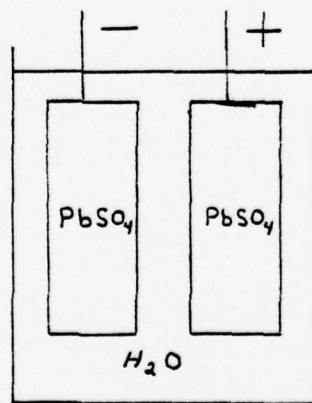

DISCHARGED
 1.130 SPECIFIC GRAVITY
 1.75 VOLTS

DISCHARGE REACTION OF A LEAD ACID CELL

FIGURE I

	NEGATIVE PLATE	ELECTROLYTE	POSITIVE PLATE
ORIGINAL MATERIALS USED	Pb	$2H_2SO_4 + H_2O$	PbO_2
IONIZATION PROCESS		SO_4^- SO_4^- $4H^+$	$4OH^-$ Pb^{++++}
CURRENT PRODUCING PROCESS	$2e^-$ Pb^{++}		Pb^{++} $2e^-$
FINAL PRODUCTS OF DISCHARGE	$PbSO_4$	$4H_2O$	$PbSO_4$

DISCHARGE
FIGURE 2

	NEGATIVE PLATE	ELECTROLYTE	POSITIVE PLATE
ORIGINAL MATERIALS USED	$PbSO_4$	$4H_2O$	$PbSO_4$
IONIZATION PROCESS	Pb^{++} SO_4^-	$2H^+$ $4OH^-$ $2H^+$	SO_4^- Pb^{++}
CURRENT REQUIRING PROCESS	$2e^-$		Pb^{++++} $2e^-$
FINAL PRODUCTS OF CHARGE	Pb	$2H_2O$ H_2SO_4 H_2SO_4	PbO_2

CHARGE
FIGURE 3

B. THEORY AND CONSTRUCTION

The fundamental parts of the lead acid storage battery are the negative plate of sponge lead and the positive plate of lead dioxide, immersed in electrolyte of sulfuric acid.

1. Theory

In 1882 Gladstone and Tuller proposed the double-sulfate theory of reaction for the lead acid storage battery. Both the positive plate and the negative plate are converted to lead sulfate as part of the process of discharge (Fig. 1). The double sulfate theory is most often stated by the equation for the reaction.

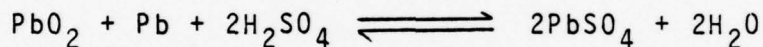

The discharge equation is from left to right; the charge equation is from right to left.

The reaction at the negative plate is

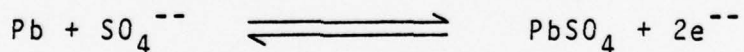

The negative plate process is relatively simple: the immersion of the lead in sulfuric acid causes it to throw lead ions into solution. These are in a divalent state, carrying 2 positive charges, causing the electrode to become negatively charged at the surface. The lead ions combine with the sulfate ions of the electrolyte which is immediately deposited on the negative plate.

The reaction at the positive plate is more complex.
The reaction is

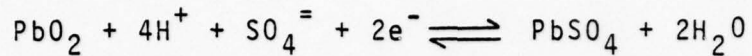

Small amounts of lead dioxide, in combination with water, ionize into tetravalent lead ions and monovalent hydroxyl ions according to the equation:

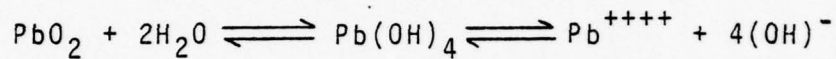

The lead then receives 2e^- from the negative plate causing a current to flow from negative to positive.

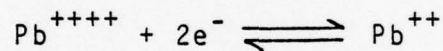

This divalent lead is free to join with the ions of SO_4^{--} in the electrolyte and the hydroxyl ions combine with the free hydrogen ions of the electrolyte to form water. The reverse of this discharge process takes place on charge (Figs. 2 & 3).

The half cell potential of the positive plate is given by the equation

$$E_{\text{pos}} = 1.75 + \frac{RT}{2F} \ln \frac{[\text{Pb}^{++++}]}{[\text{Pb}^{++}]}$$

where

$[\text{Pb}^{++++}]$	tetravalent lead ion activity
$[\text{Pb}^{++}]$	divalent lead ion activity
R	gas constant 8.134 joules/degree mole
F	Faraday constant 96500 coulombs
T	Temperature

The negative plate potential is

$$E_{\text{neg}} = -.12 + \frac{RT}{2F} \ln [\text{Pb}^{++}]$$

The cell voltage is the difference between these two potentials or

$$E = E_{\text{pos}} - E_{\text{N}} = 1.87 + \frac{RT}{2F} \ln \frac{[\text{Pb}^{++++}]}{[\text{Pb}^{++}]}$$

In the normal cell this corresponds to an open circuit voltage of 2.125 volts in a 1.280 Sp.Gr. electrolyte and 25°C.

The limiting processes of the lead acid battery are well known to be mass transport and ionic diffusion within the porous positive and negative electrode structures. This causes these structures to be important to the capacity and life of a battery.

2. Materials

The material used in greatest amount is lead, which is an element having an atomic weight of 207.21. Lead is a metal, bluish gray in color, with metallic luster. It is a soft metal with a low melting point at 327.4°C. The chemical properties of lead are of great importance to storage-battery performance. Lead is readily attacked by nitric acid, but not by cold hydrochloric acid, or cold sulfuric acid below 1.700 Sp.Gr. Lead can be combined with oxygen to form some important oxides which will be discussed in later paragraphs. Lead is very sensitive to small amounts of impurities. Arsenic, calcium, and antimony are hardening agents for lead.

Bismuth increases the corrodibility of lead. The battery industry is one of the largest consumers of lead. Although heavy consumers about 80 percent of the lead used is recoverable.

The materials in the lead acid battery whose chemical combinations absorb or produce energy during the charge and discharge of a cell are known as the "active materials".

These consist of:

- (1) Lead-dioxide (Positive plate)
- (2) Sponge lead (Negative plate)
- (3) A solution of sulfuric acid and water (electrolyte)

The active material is formed on plates, of which there are two types. The difference between the two lies in the way they derive the active material. The Plante' plate, which derives its active materials by oxidizing the surface of a lead plate (positive), or reducing the lead plate surface to sponge lead (negative), is one type. The other type is the pasted plate or Faure plate. It derives its active material from pastes mechanically applied to a grid network to form flat plates. These pastes are then oxidized or reduced to form the positive and negative plates. This investigation studies the pasted plates. The process of oxidizing the positive plate and reducing the negative plate is called formation.

The negative plate of sponge lead tends to coalesce and densify. Expanders are added in small amounts to the paste for making the negative plate. Two of the most common

are lignin and barium-sulfate. There have been many papers pertaining to the effect of lignin and barium-sulfate most attributing the effect of the additives to the modification that they caused in the lead sulfate crystal structure during the discharge. A. C. Simon [4] showed that lignin produced a marked change in the microstructure of the charged negative plate. When barium-sulfate and lignin were used together additional changes took place. These additional changes acted to cause a further increase in surface area and increased porosity. These were in addition to the beneficial effect these two compounds had on the growth of the lead-sulfate during discharge. Therefore most negative plate pastes contain expanders.

The positive active material is lead dioxide (PbO_2), also called plumbic oxide. It is dark brown or almost black in color. It is formed electrolytically in the battery by anodic oxidation of lower oxides, primarily PbO or Pb_3O_4 . The paste to form this lead dioxide is prepared by mixing some particular lead oxides or a blend of oxides with a dilute solution of sulfuric acid. The composition of and mixing of these pastes are as varied as the companies who produce batteries. Some of the important patents pertaining to the paste composition are given in reference 5. These pastes are mechanically pasted on grids. After the formation of this paste into the active material, several features of this active material are important, including (1) the mechanical stability of the active mass; (2) the microscopic

of the grid. Total penetration of the grid can cause some of the active material of the plate to become electrically isolated and unable to contribute to the reaction process. Another aspect of corrosion is that the corrosion product on the grid-active material interface can impair the electrical conductivity of this interface and the active material's adherence to the grid.

Currently and historically, the most common lead acid battery grid alloy systems are based on cast lead-antimony and lead-calcium binary alloys. These will be discussed in detail. Other alloy systems currently being developed are pure lead, dispersion strengthened lead, lead-calcium-tin alloy and more [6].

Lead-antimony alloys have historically been the most common grid alloy system. Lead and antimony form an alloy of which the eutectic composition is 87 percent lead and 13 percent antimony, with a melting point of 477°F (Fig. 4).

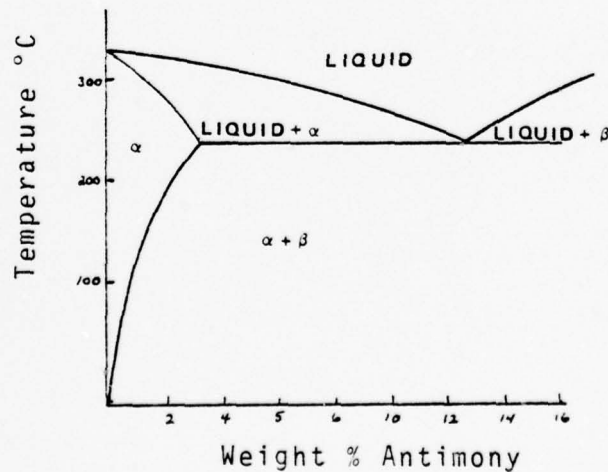

The Lead-Antimony Phase Diagram

morphology of the plate; (3) the electrochemical "activity" of the compound present; (4) adherence of the active material to the grid. These features will be discussed later in theories of loss of capacity.

The third active material of the lead acid battery is the electrolyte. The electrolyte for lead acid batteries is a solution of sulfuric acid. The electrolyte is prepared by diluting pure sulfuric acid with pure water. The purity of the sulfuric acid and the water is critical. Standards are set for both the water and acid [11] (Tables I, II). The specific gravity of the battery acid is determined by the service of the battery. The range is from 1.200 to 1.285. Submarine batteries are one of the highest in specific gravity at 1.285.

The grid performs two major functions in the battery, (1) to serve as supports for the active material of the plates, and (2) to conduct the electric current in and out of the active material. The specific lead alloys used for grids are important with respect to both functions of the grids. Both the action of the electrochemical activity and concurrent structural role tends to both weaken the grid and reduce its electric conductivity.

Strength is desirable for two distinct reasons. The first is during fabrication for ease of handling and pasting. It is also useful during battery service, as the grids frequently bear significant loads (the active material, their own weight, and stresses induced by corrosion).

Corrosion resistance is also important to the grid. Corrosion can cause a decrease in the electrical conductivity

The amount of antimony in storage-battery grids ranges from 3-12 weight percent, with the modern trend toward the lower percentages. The structure of the alloys used in storage batteries consists of the eutectic embedded in a solid solution of lead and antimony, as shown in Figure 5. There are

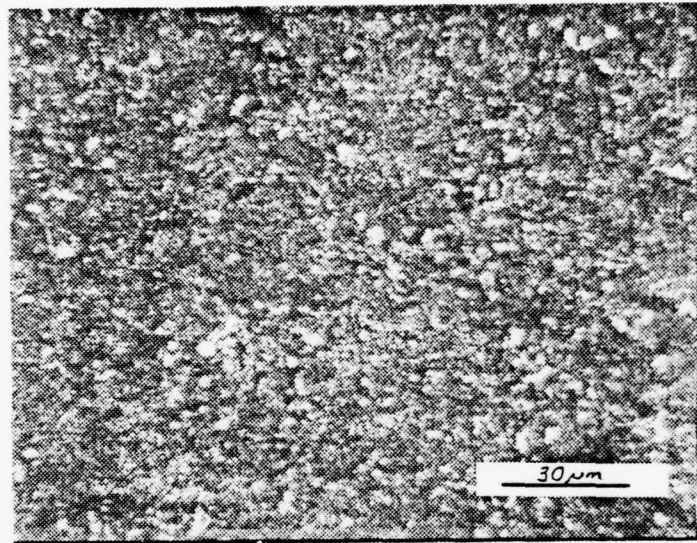

Figure 5. Microstructure of the lead-antimony grid material from a submarine type battery plate.

a number of reasons to use antimony in grids: (1) antimony increases the fluidity of the metal in the mold; (2) antimony increases the stiffness of lead, and its tensile strength in percentages up to 12 percent; (3) antimony has a beneficial effect on the positive plate active material during cycle life [7].

There are also disadvantages to the use of antimony in the grid. Antimony is a poison to the negative plate.

It lowers the hydrogen overvoltage and leads to "self discharge" of the negative plate. Arsenic is the principal impurity that is associated with antimony. Inside the battery the presence of arsenic causes toxic arsine (AsH_3) gas to be evolved. The removal of the antimony that migrates to the negative plate is accomplished by applying a high end of charge current. This high finishing current creates two disadvantages. (1) Water is used during this period increasing the maintenance required by the battery. (2) The antimony is driven out of the negative plate by the current as toxic stibine gas. Therefore charging in confined spaces may present a health hazard.

There are currently two methods of overcoming these disadvantages. One way is to reduce the antimony to below 3.5 percent which reduces water usage but not the other problem. The other approach is to remove the antimony by using another alloy system. The most common of the antimony-free systems is lead-calcium alloys. This method not only overcomes the deleterious effects of antimony, but the beneficial aspects as well. The lead-calcium alloys for battery grids were first described by Haring and Thomas [12] in 1935.

Lead-calcium alloys represent a classical precipitation-hardening binary system. They are strengthened over time by precipitation of very fine Pb_3Ca particles from a supersaturated solid solution, as predicted by the equilibrium phase diagram of Figure 6. Up to 0.07 percent calcium, strength increases with increasing calcium content. At

calcium contents above .07 percent, large primary Pb_3Ca crystallites, which have been shown to be detrimental to mechanical properties and corrosion resistance, are formed. This effect can be minimized up to .1 percent by rapid cooling but are almost impossible to avoid above this. Less

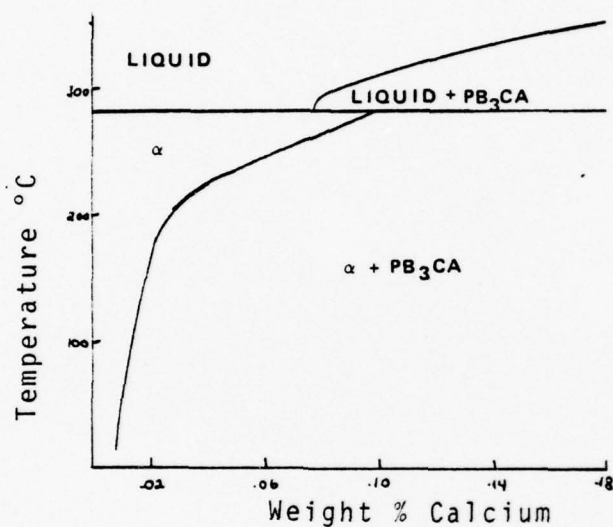

Figure 6. The Lead-Calcium Phase Diagram

than .08 percent is used for battery applications. The typical microstructure of a Pb-Ca storage battery alloy consists of essentially pure lead grains with a dispersion of Pb_3Ca particles, the amount and distribution depending on alloy content and cooling rate [8] (Fig. 7).

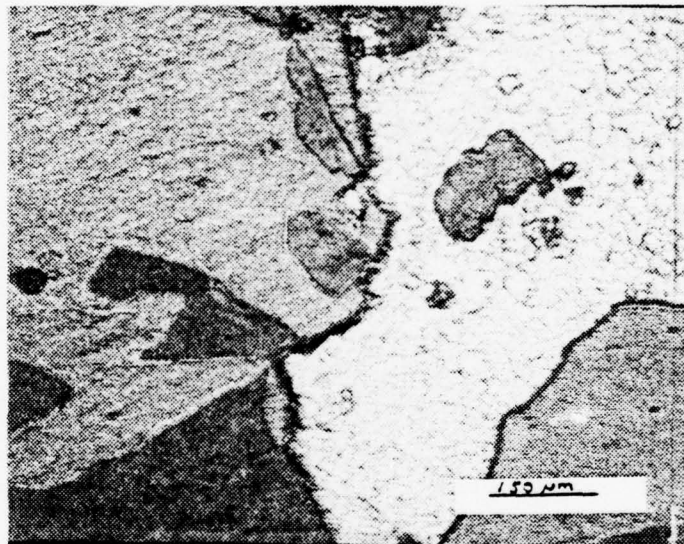

Figure 7. Microstructure of the lead-calcium grid material from a submarine type battery plate.

The primary advantage of lead-calcium alloys is the elimination of the deleterious effects of antimony. They have a significantly lower self-discharge, so they can stand on open circuit without loss of capacity. These alloys are more conductive than lead-antimony. The current needed to maintain them on float is 4 to 10 times less than needed for a lead-antimony battery.

The main disadvantage of Pb-Ca alloys relates to an inability to promote optimum active material performance. In this respect lead-calcium batteries have poor deep cycle life due to shedding and softening of positive active material [10]. An example of these problems is suspected in the failure of non-diesel submarine batteries on a modified full float service.

To keep the plates of opposite polarity from making metallic contact, separators are placed between the alternating positive and negative plates in storage batteries. Present types of separators include those of wood veneer, perforated and slotted separators of hard rubber, microporous rubber, fibrous glass mats, microporous plastics, resin-impregnated fibrous material and more.

The essential features of any separator are

- (1) high porosity; this insures low resistance to passage of current between plates and free diffusion of acid;
- (2) high electrical resistance to prevent short circuit conduction between plates of opposite polarity;
- (3) inertness to the action of sulfuric acid and electrochemical oxidation;

(4) absence of harmful impurities;

(5) mechanical strength because separators which are easily damaged or split are a source of internal short circuits.

Submarine cells and most batteries intended for heavy duty also use what is called a retainer on the positive plate usually a glass-wool mat. The glass-wool mat serves to retain the active material of the positive plate and to provide a reservoir for the electrolyte. The porous glass separators are always used in combination with other types of separators such as microporous rubber.

The construction of a battery cell is just the combination of the above materials in an ordered arrangement. In its simplest form the pasted-type cell consists of a group of positive plates connected to a common terminal bar and a similar group of negative plates, always one more than the positive group, assembled together. The positive plates may or may not be covered by a retainer depending on the type of the battery being constructed. Separators are placed between the plates of opposite polarity. This assembled arrangement is called an element. The element is then placed in a suitable container. In recent years new plastics such as PVC, polystyrene, polypropylene, and others, have become popular in smaller storage cells. The advantage of using these plastics over the old hard block rubber is that they have thin walls for the same strength, so more active material can be placed in the battery giving greater capacity.

C. CAPACITY AND OPERATION

The capacity of a storage battery may be expressed either as the ampere-hour capacity or as the watt-hour capacity. The ampere-hour capacity is a measure of the electrochemical reactions or in other words a measure of the electricity that the battery is able to deliver. The watt-hour capacity, on the other hand, is a measure of the energy, the ability to do work, of the battery. The ampere-hour capacity rating is most often used. It is the product of the current and time. For example a battery at 30 (Ah) at 1/2 hour rate means it will give 60 amperes for 1/2 hour. At a lower current it will usually give greater capacity and at a higher current it will have less capacity.

Principal factors that effect capacity of storage cells include: the amount of material within the cell, thickness of plates, rate of the discharge, temperature, quantity and concentration of electrolyte, porosity of the plates, plate design, and age of the plates. These factors will be discussed later. A detailed explanation of these parameters can be found in reference 1.

The most widely used equation which relates the current to time, in order that the capacity of batteries can be computed at varying rates of discharge, is Peukert's equation

$$I^n t = C$$

where n and C are constants
 I current in amperes
 t time in hours

The constants can be evaluated for a given battery by simple discharge tests.

$$n = \frac{\log t_2 - \log t_3}{\log I_1 - \log I_2} \quad C = I_1^n t_1$$

Being logarithmic it can be plotted as a straight line on log-log paper.

The operation of lead-acid storage batteries has two modes corresponding to the two directions of the chemical reaction-charge and discharge.

In the discharge mode the battery gives out energy usually at a constant current with voltage dependent upon the state of charge of the battery. In a constant current discharge the voltage will decrease to some limiting value, at which time the battery is said to be fully discharged. The limiting values vary with the rate of discharge of the cell and usually range from 1.85 volts per cell to 1.5 volts per cell. Typical discharge curves are shown in Figure 8.

The purpose of charging a battery is to replace the stored energy removed by discharge. There are three common methods of accomplishing this; (1) constant current charge, (2) constant potential charge, (3) the modified constant potential charge.

In the constant current system, the current is held constant during the main part of the charge. When the battery is gassing freely the current is reduced to a rate about equal to 40 percent of the 8 hr rate, called the finishing rate.

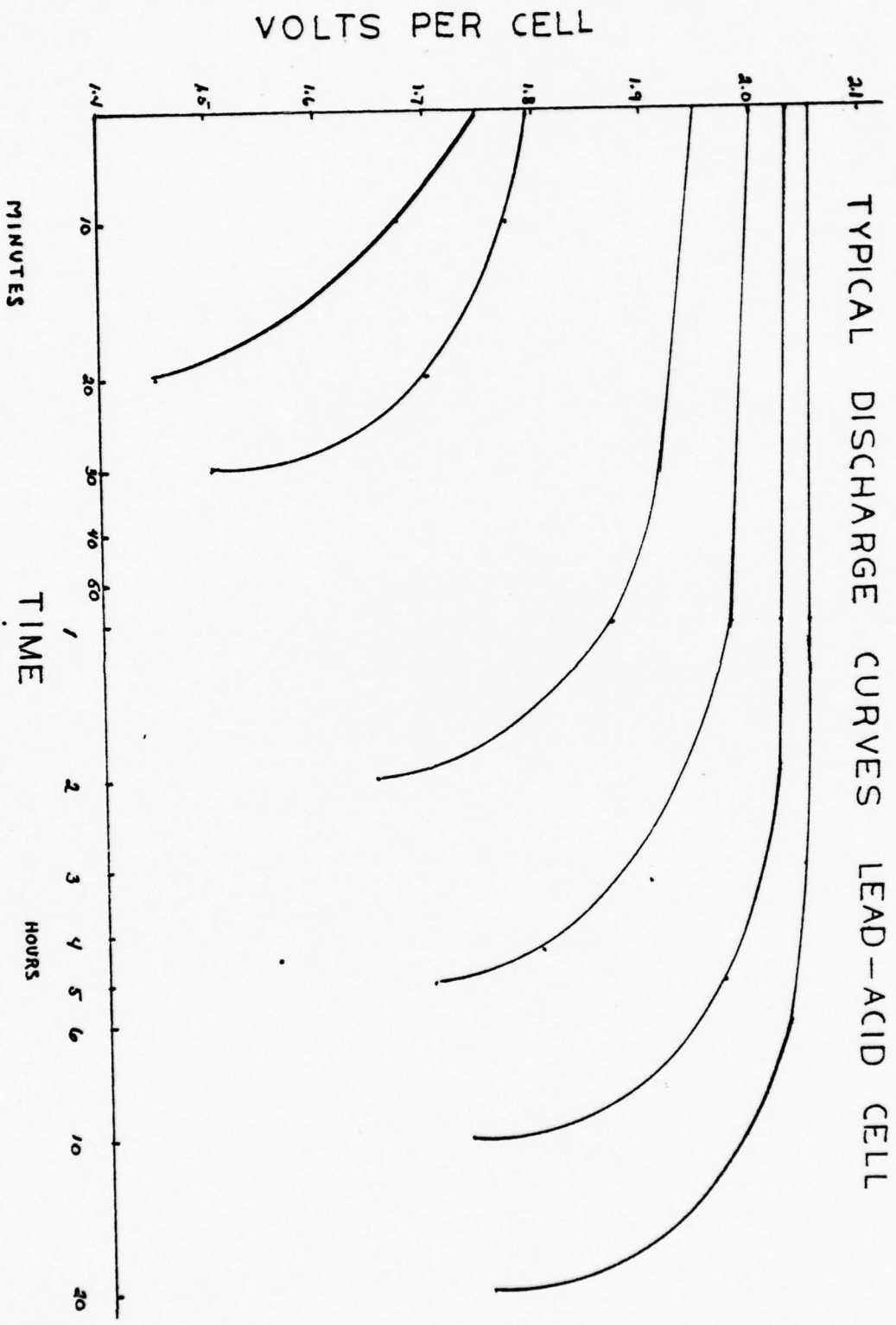

TIME
MINUTES
HOURS
FIGURE 8

The charge is over when the battery gasses freely at this rate. In large storage batteries this one step method can be modified to a multistep charge as shown in Figure 9.

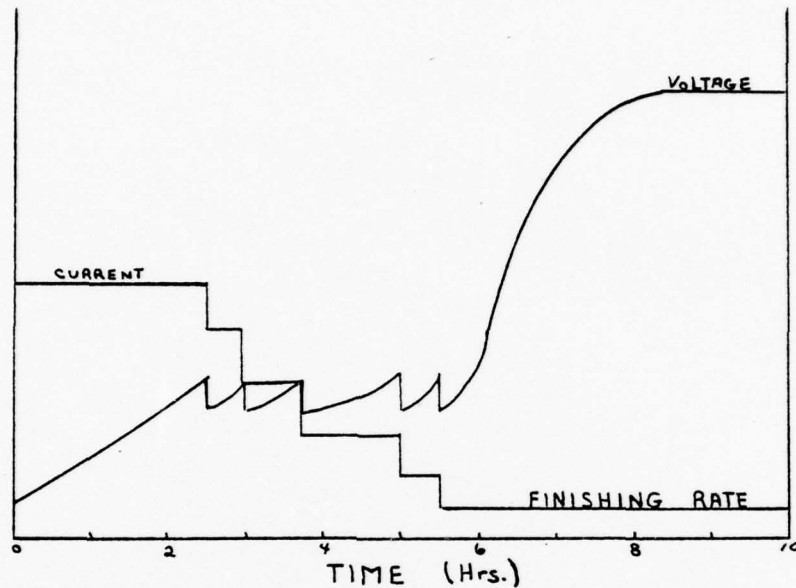

Figure 9. The current vs time and voltage vs time plots of a constant current step type battery charge.

In the constant potential charge method the voltage is maintained at a constant fixed value per cell. This constant voltage is set by the gassing voltage of the battery which is controlled by the temperature of the cell at the start of charge. At the start of charge a large current passes into the battery. As the battery's back e.m.f. increases, the charging current decreases fairly quickly. Near the completion of charge, it reaches a value less than the finishing rate. Normally when the finishing rate is reached the charge is continued at a constant current mode at the finishing rate as shown in Figure 10.

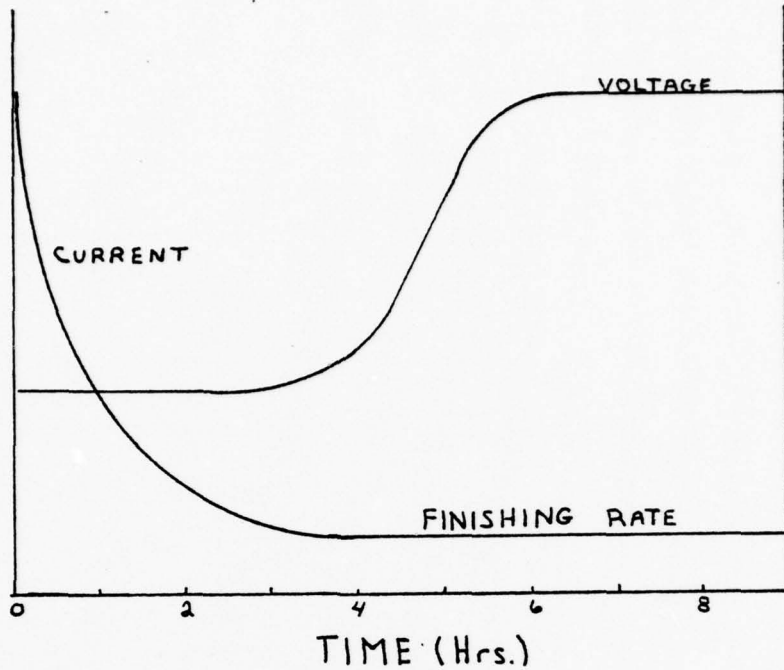

Figure 10. The current vs time and voltage vs time plots of a constant potential type battery charge.

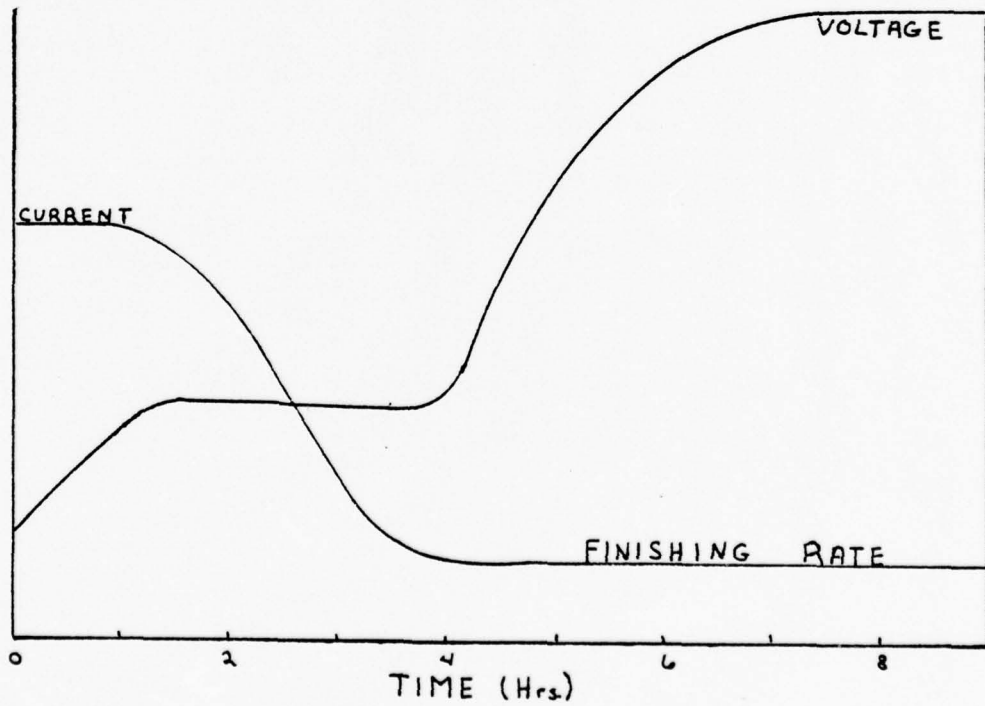

Figure 11. The current vs time and voltage vs time plots of a modified constant potential type battery charge.

The modified constant potential method is used for most large batteries. In the constant potential method a very large starting current is required for a short time. These large current requirements increase the cost and size of the equipment needed to charge a battery. The modified constant potential method allows the use of smaller equipment using the constant maximum current of the equipment at the start and allowing the battery voltage buildup to TVG (the temperature and voltage at which gassing starts). The charge then continues at a constant voltage of TVG until the finishing rate is reached, at which time it shifts back to a constant current charge until secured. This method is shown in Figure 11.

D. CAPACITY LOSS

It has been known from the early development that two factors seemed to control the capacity and useful life of a battery: (1) the mass transport and diffusion of the electrolyte into the active material, and (2) the shedding and loss of the active material from the grid structures. If diffusion of the electrolyte is impaired, the active material becomes acid starved and the reactions cannot take place to release the chemical energy stored. Obviously if the active material loses contact with the grid it can no longer enter into the reactions, and this then lowers the capacity of the battery.

Until recent times, corrections of the symptoms were attempted, and if successful, were incorporated in the design.

Since the advent of electron microscopy, both transmission and scanning, and new techniques in light microscopy, the structures and their changes during the life of a battery have received attention. The incidence of unexplained capacity loss in diesel-electric submarine battery cells adds emphasis to the reasons for capacity loss in antimony-free batteries. This is also the reason for this investigation into the capacity loss of antimony and antimony-free batteries.

Many theories have evolved on the capacity loss problem as a result of these investigations.

J. Burbank [7,13,14] showed, using replica transmission electron microscopy, that there was a marked difference in the morphology of lead dioxide between plates with antimony alloy grids and those with antimony-free grids. She believes that the antimony is beneficial to the positive plate active material. The antimony in some way retarded the grain growth of the lead dioxide particles. Without the antimony, the crystal morphology of active material in the positive plate becomes important.

S. Tudor, A. Weisstuch, and S. H. Davang [15,16,17], using autoradiography, saw that in thin calcium-grid batteries, failure was caused by a barrier layer of lead-sulfate at the grid active material interface. This lead-sulfate layer was present between grid and active material even in the charged state. A report by E. Zehende supported this explanation.

G. W. Mao and D. L. Douglas [18] showed that in the case of the antimony lead alloy, the lead dioxide on the grid was

relatively porous and had a relatively high resistance, while in non-antimonial lead alloy except lead calcium the primary lead dioxide was denser and had a lower resistance.

A. C. Simon and S. M. Caulder [19,20] have shown that two forms of lead dioxide exist. One is electrochemically active and the other electrochemically inactive. Using thermal mass spectroscopy, NMR, and microscopy they showed that as the lead dioxide/lead-sulfate electrode was cycled, the electrochemically active lead dioxide, which may be an amorphous compound, underwent a structural reordering with the loss of a hydrogen species. This structural reordering caused an electrochemically inactive lead dioxide, with loss of battery capacity and ultimate failure.

As mentioned above, several explanations have been put forth for the accelerated capacity loss and failure of antimony-free grid batteries. One of these causes may be the explanation of capacity loss and failure, or a combination of these causes may work together to lower the capacity of a battery. It is also possible that there still exist undiscovered explanations.

This investigation attempted to explain the failure mode of submarine-type lead-acid storage batteries in a deep-cycle routine. The structures and structural changes over the age of the battery were examined using scanning electron microscopy. The main thrust of the analysis is on the structures of the interface between grid and active material, for

a possible corrosion product inducement of failure, or a structural change of this area which may be related to capacity loss of the battery. The structural changes in the active material, both near the grid and within the bulk of the plate, were also studied.

II. EXPERIMENTAL PROCEDURES

A. CONSTRUCTION OF THE CELL

The test cells were constructed of parts taken from standard production line submarine batteries. A complete cell, a Gould Inc. TPX-61-E milspec 24200/5, was obtained from Mare Island Naval Shipyard. This cell provided the antimony grid plates and all the separators, retainers, and binding strips used in the construction of the test cells. The terminals of this cell were damaged in transit to the shipyard, but the plates were undamaged. Three positive and six negative calcium grid plates, taken from a Gould Inc. TLX-39B milspec 24200/7, were received directly from Gould's Kankakee, Illinois, factory. Currently Gould Inc. is the only supplier of submarine batteries to the United States Navy. The plates were received, cured, and formed in a dried condition, as they would be delivered for shipboard installation. They were then cut into smaller sections in order to construct the small test cells used in this investigation.

All cells constructed consisted of one positive plate between two negative plates with standard separators, retainers and binding strips (Figure 12). The antimony grid positive plates measured 13 cm (5.1 in) X 11.5 cm (4.5 in) and the thickness varied from 0.42 cm (0.165 in) to 0.45 cm (0.175 in). The antimony negative plates measured 13.5 cm (5.3 in) X 11.5

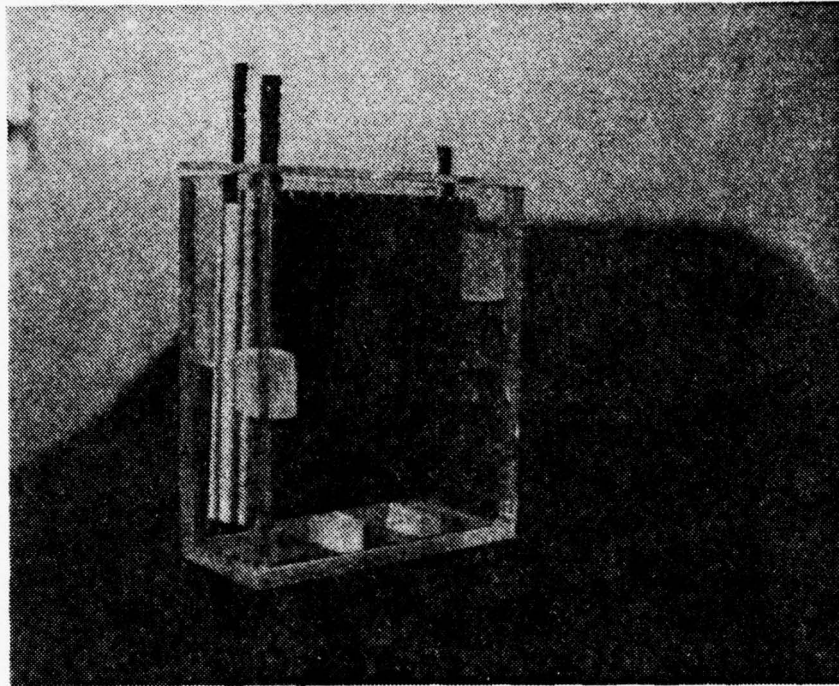
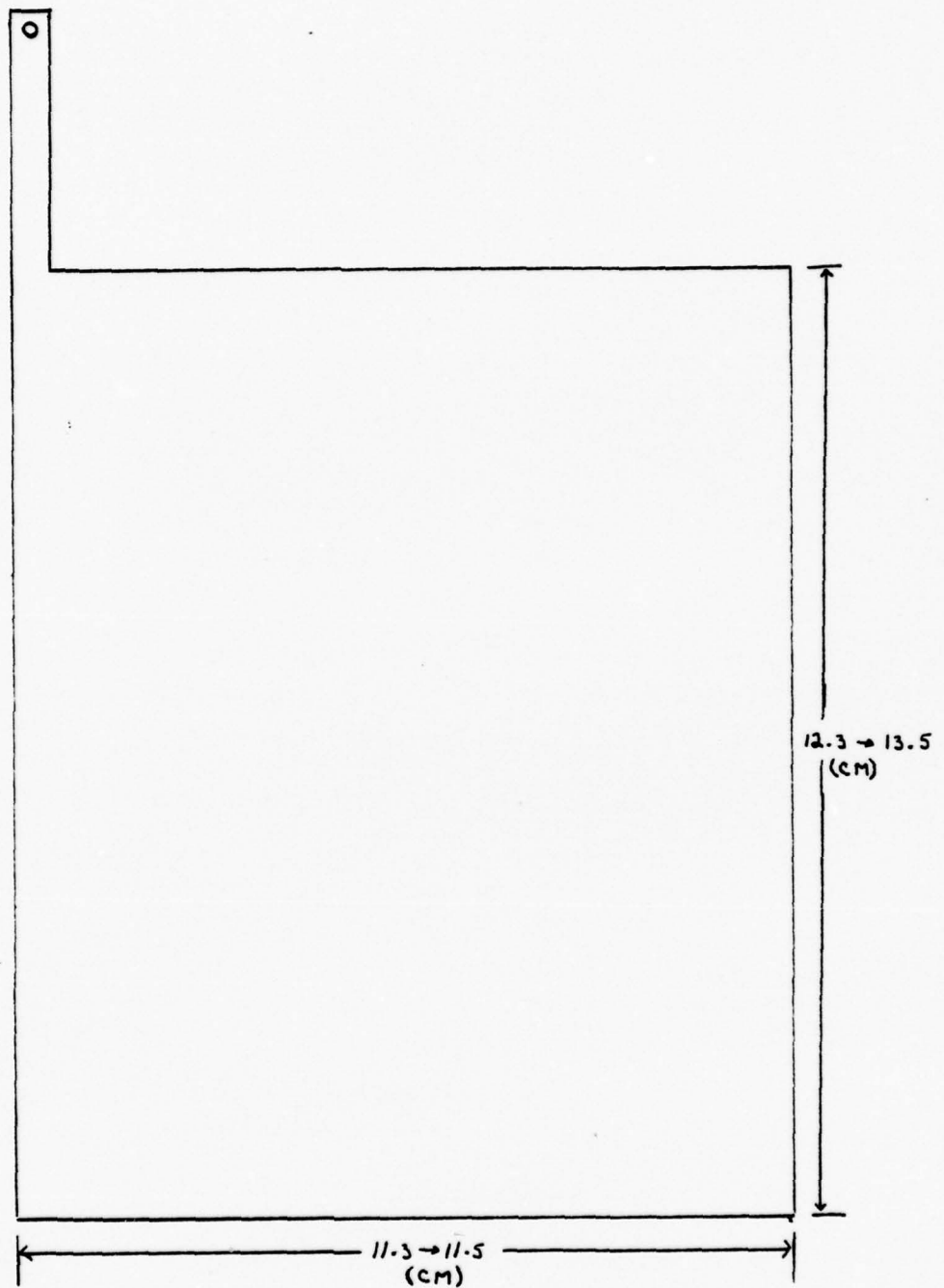

Figure 12. View of the typical test cell used in this investigation.

cm (4.5 in) and the thickness varied from 0.28 cm (0.11 in) to 0.30 cm (0.12 in). The calcium grid positive plates measured 12.3 cm (4.8 in) X 11.3 cm (4.45 in) and the thickness varied from 0.48 cm (0.19 in) to 0.5 cm (0.20 in). The calcium negative plates measured 13.5 cm (5.3 in) X 11.4 cm (4.49 in). The thickness varied from 0.37 cm (0.145 in) to 0.39 cm (0.155 in) (Figs. 13 & 14).

The positive oxide pastes of both type plates were a leady oxide produced by the ball mill method, having a minimum free lead content of 45 percent. Both the negative and positive plates contained dacron fibers as a bonding material and filler in the pastes.

The separators were all microporous rubber taken from the TPX 61E. This separator is used in all submarine-type batteries constructed by Gould. All separators were cut to the same size 13.9 cm (5.47 in) X 11.7 cm (4.6 in). The thickness of the separators measured .127 cm (.05 in) on the flat and .254 cm (.1 in) at the ribs. The separators were unintentionally placed in the test cells with the flat side against the glass wool retainer of the positive plate. Test battery PbCa#2 was constructed with the ribbed side of the separator positioned against the glass wool retainer of the positive plate. No significant difference was observed between the cycling parameters of PbCa#1 and PbCa#2. It was thus concluded that the separator orientation had little effect on the parameters of the test.



TYPICAL TEST PLATE
FIGURE 13

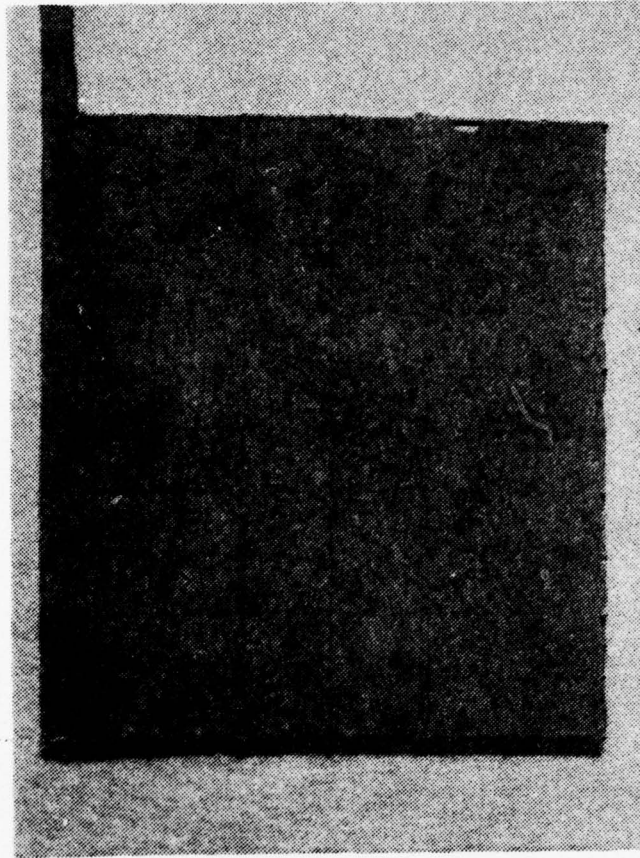

Figure 14. A typical positive plate used in the construction of the test cells.

The glass wool retainer material was cut to a size sufficient to cover the active material of the positive plate. This material measured .084 cm (.033 in) thick when dry. Binding strips 13 cm (5.1 in) long were used to hold the retainer on the positive plate.

The jars of the cell were constructed of .636 cm (.25 in) thick clear plexiglass. The dimensions of a jar are shown in Figure 15. A "U" shaped bridge of plexiglass was placed in the bottom of each jar, creating a space of approximately 1/2 in for sediment settling. The elements were wedged in the jar using scrap pieces of plexiglass.

The covers for the cells were constructed of 0.38 cm (.125 in) thick plexiglass. The terminals of each plate passed through these covers, as shown in Figure 16, and were sealed using a commercial silicone glue and sealer. A 3/4 in round hole in the cover served as a service entrance for obtaining specific gravity, temperature and reference electrode readings during operation of the battery.

The cells were bussed together to form three-cell batteries of approximately 6 volts. The bus bars consisted of pieces of battery grid from the top of the various plates used. A wiring diagram for the voltage-measuring leads and the current-conducting power leads is shown in Figure 17. These were then put into a terminal board (Fig. 17) to facilitate the connection of monitoring equipment and charge and discharge equipment. The bus bars were connected to the cells using 2-56/64 stainless steel nuts and bolts. Due to

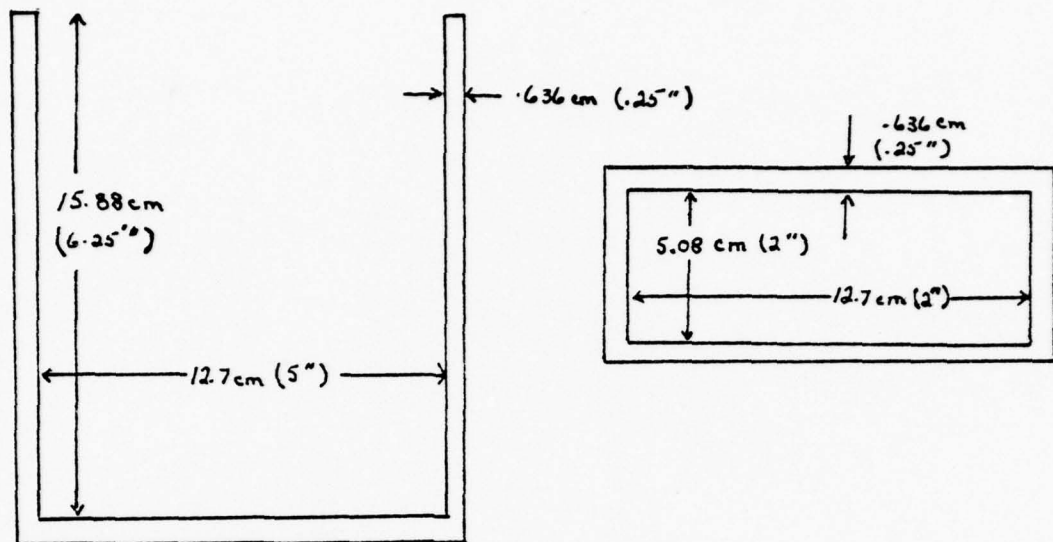

FIGURE 15

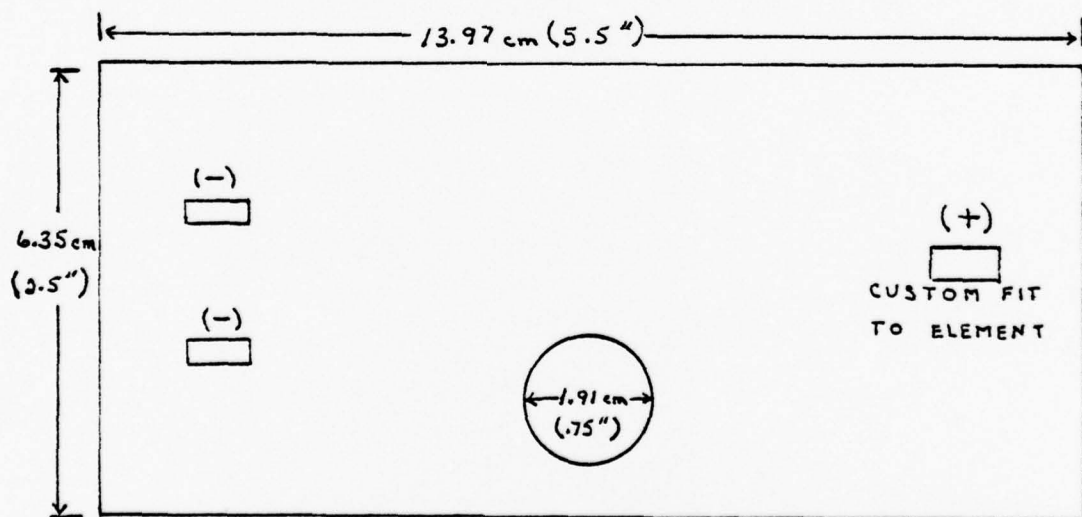
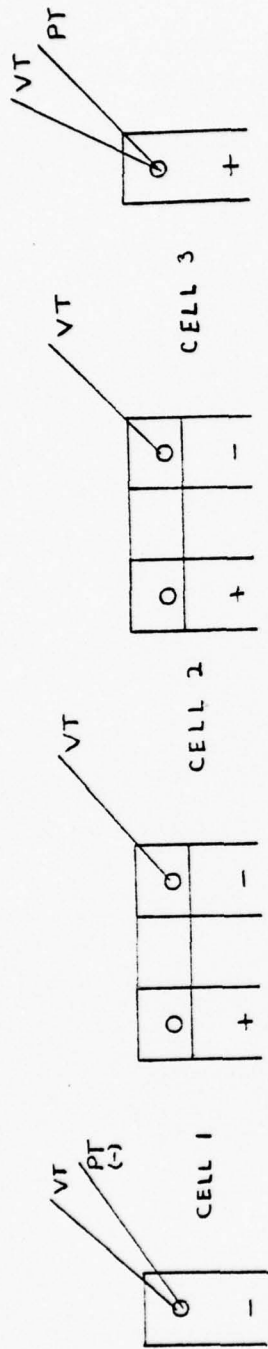
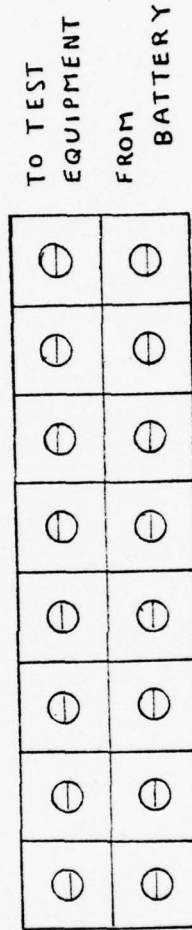

FIGURE 16



VT = VOLTAGE LEAD

PT = POWER LEAD



TERMINAL BOARD OF BATTERY

FIGURE 17

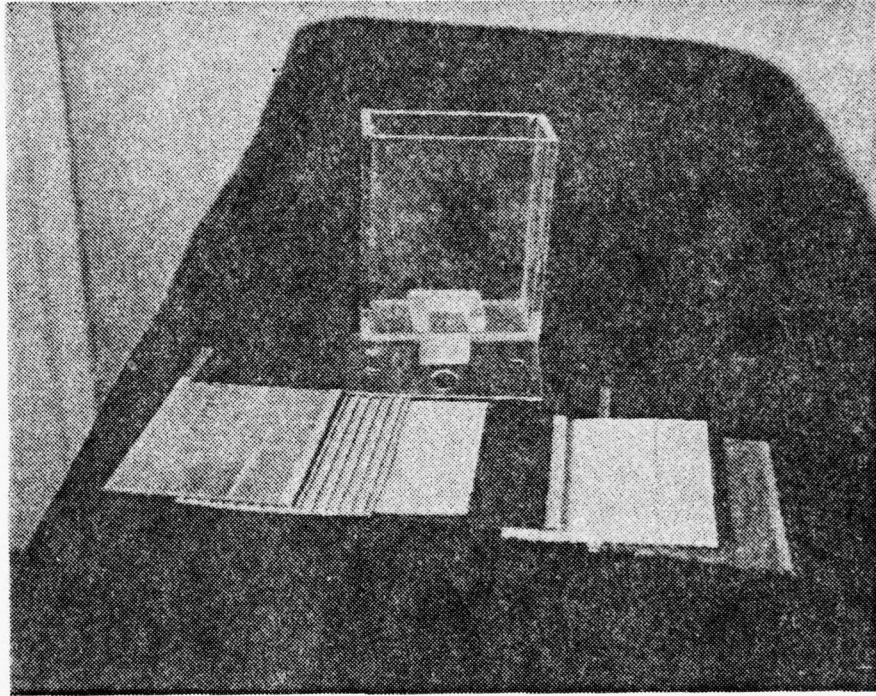

Figure 18. Typical element construction of the test cells.

corrosion at the terminals these connectors required frequent replacement.

B. CAPACITY RATING OF BATTERY

Using Farraday's Law in conjunction with the reaction equation, the maximum capacity available from the active material necessary for one ampere-hour of capacity from the lead acid system is 3.866 grams of lead, 4.463 grams of lead dioxide, and 3.660 grams of sulfuric acid. The test batteries were constructed to be positive material limited, therefore the lead dioxide of the positive plate will limit the reaction. The lead calcium positive plate contained approximately 206.4 grams of positive active material, which related to a maximum capacity of 46.25 ampere-hours. The lead antimony positive plate contained approximately 189.2 grams of active material. This corresponds to a maximum capacity of 42.39 ampere-hours. The foregoing figures showing the capacity are based entirely upon theoretical considerations. Practical amounts of the active material needed in a real battery are from 3-5 times as much as predicted from theory, depending on the type of cell and the thickness and number of plates.

There are several reasons for the limited use of the active materials. The lead sulfate that is formed during the process of discharge is a non-conductor and increases the resistance of the active material of the plate. When the active material contains 50 percent of sulfate, the resistance has risen to a very high value. In addition the lead sulfate

formed in the plate tends to close the pores of the material, which hinders the diffusion of the electrolyte. As the electrolyte is consumed, its resistance is increased. The minimum resistivity of the electrolyte occurs at a specific gravity of approximately 1.225. Due to the overabundance of electrolyte in the test cells used, the gravity seldom fell below 1.200. A fourth reason, which involved the design of the plate itself, is the limited contact between the active material of the plate and its support or grid.

The ratio of the amount of active material taking part in the reactions to the total amount of active material present in the plates is called the coefficient of use. A cell of good quality will normally have a coefficient of .25 or more.

The actual capacity of the test cells was determined by tests during the first 20 cycles of the battery's life. Discharge currents from 2.0 to 4.5 amperes were used to rate the batteries. A current versus time relationship was plotted on log-log paper. Peukert's equation, being logarithmic, can be plotted as a straight line on log-log paper. The results of these tests are given in Figures 19-22. The straight line of the graph represents 100 percent capacity for a particular battery. Values of time and current above this line represent greater than 100 percent and values below this line represent less than 100 percent. The rated capacity at the 6 hr rate for each of the batteries tested was: PbSb#1 - 20.1 ampere-hour; PbSb#2 - 19.2 ampere-hours; PbCa#1 - 18.6 ampere-hour; and PbCa#2 - 17.4 ampere-hours. These values give a coefficient

PBSB 1

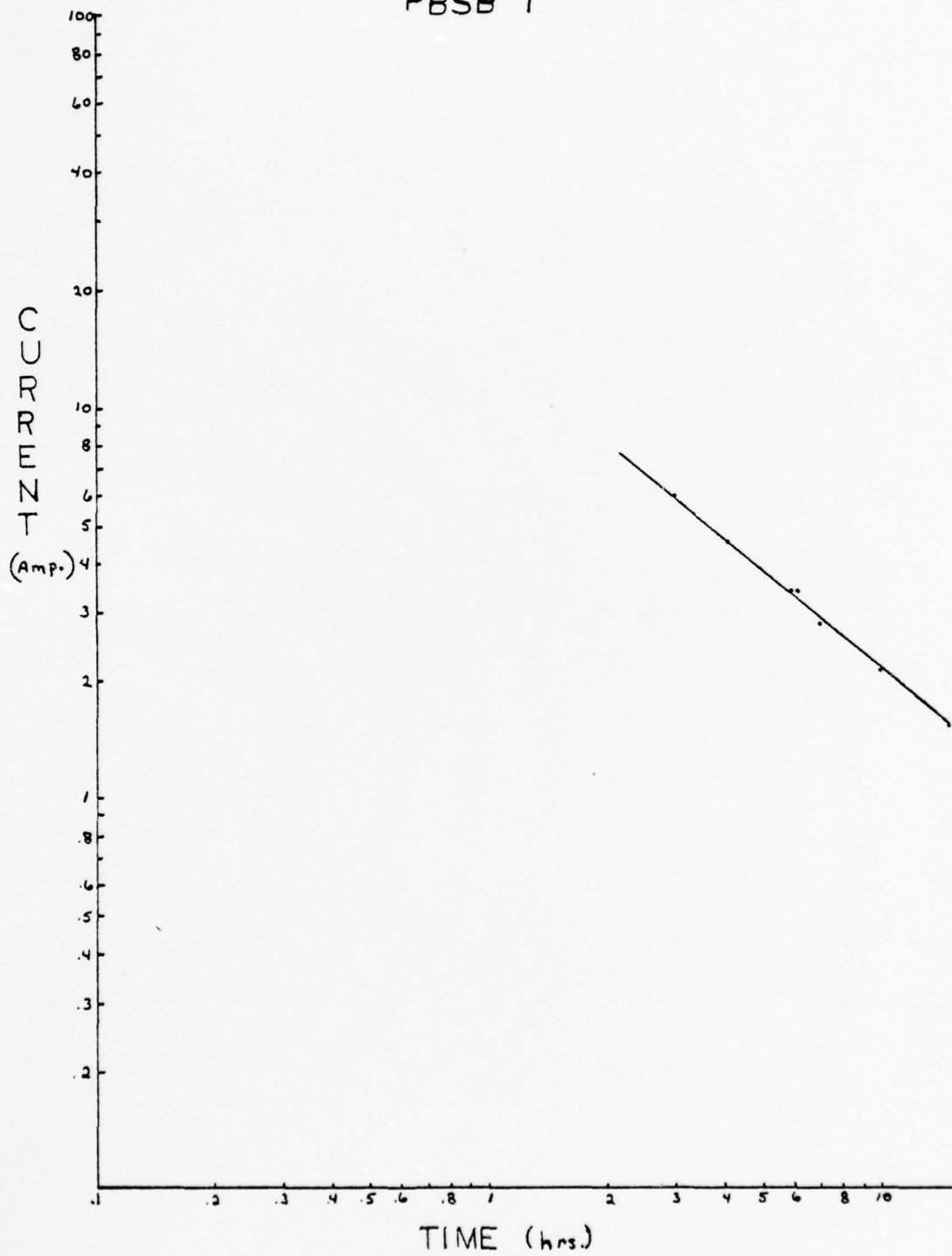

FIGURE 19

PBSB 2

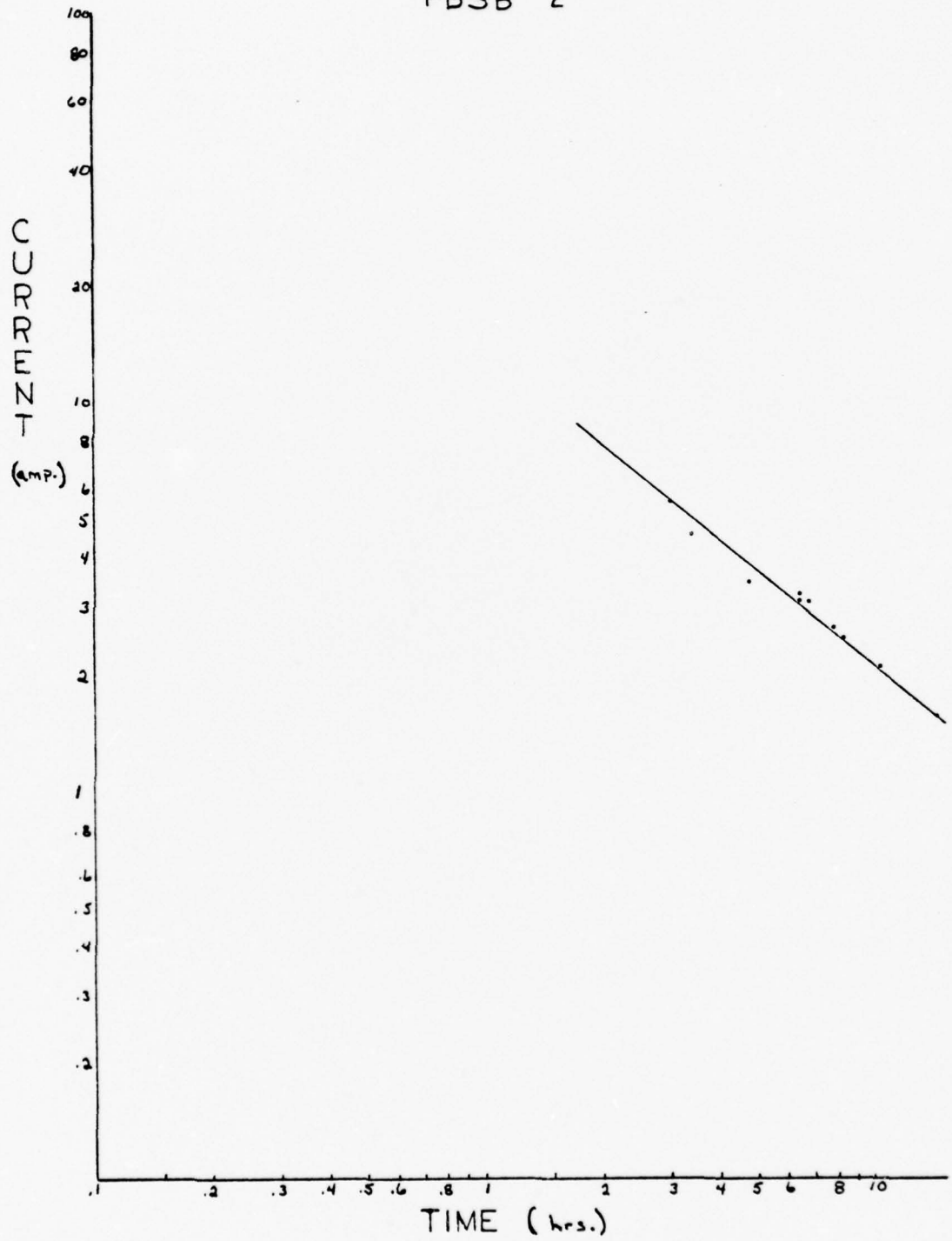

FIGURE 20

PBCA I

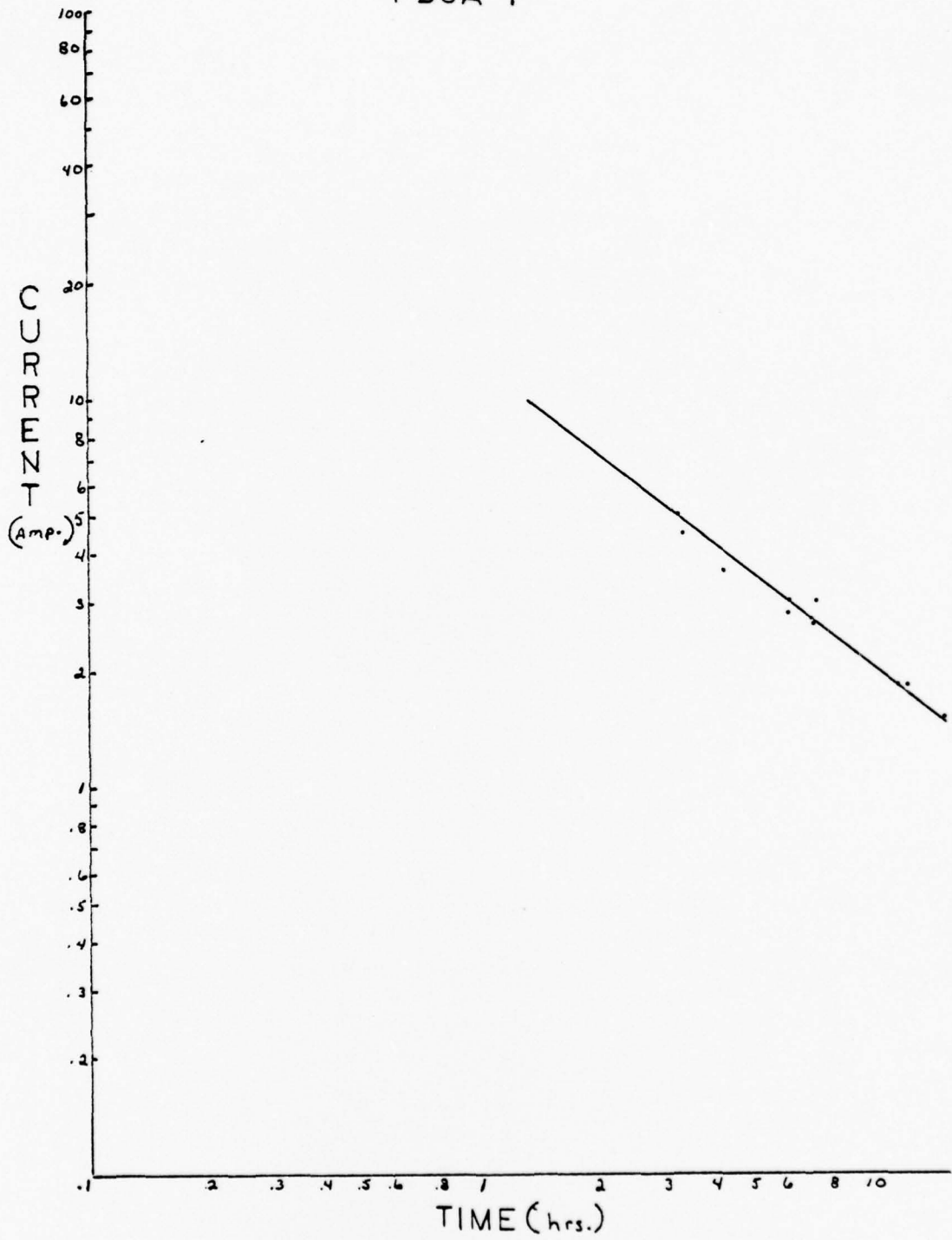

FIGURE 21

PBCA 2

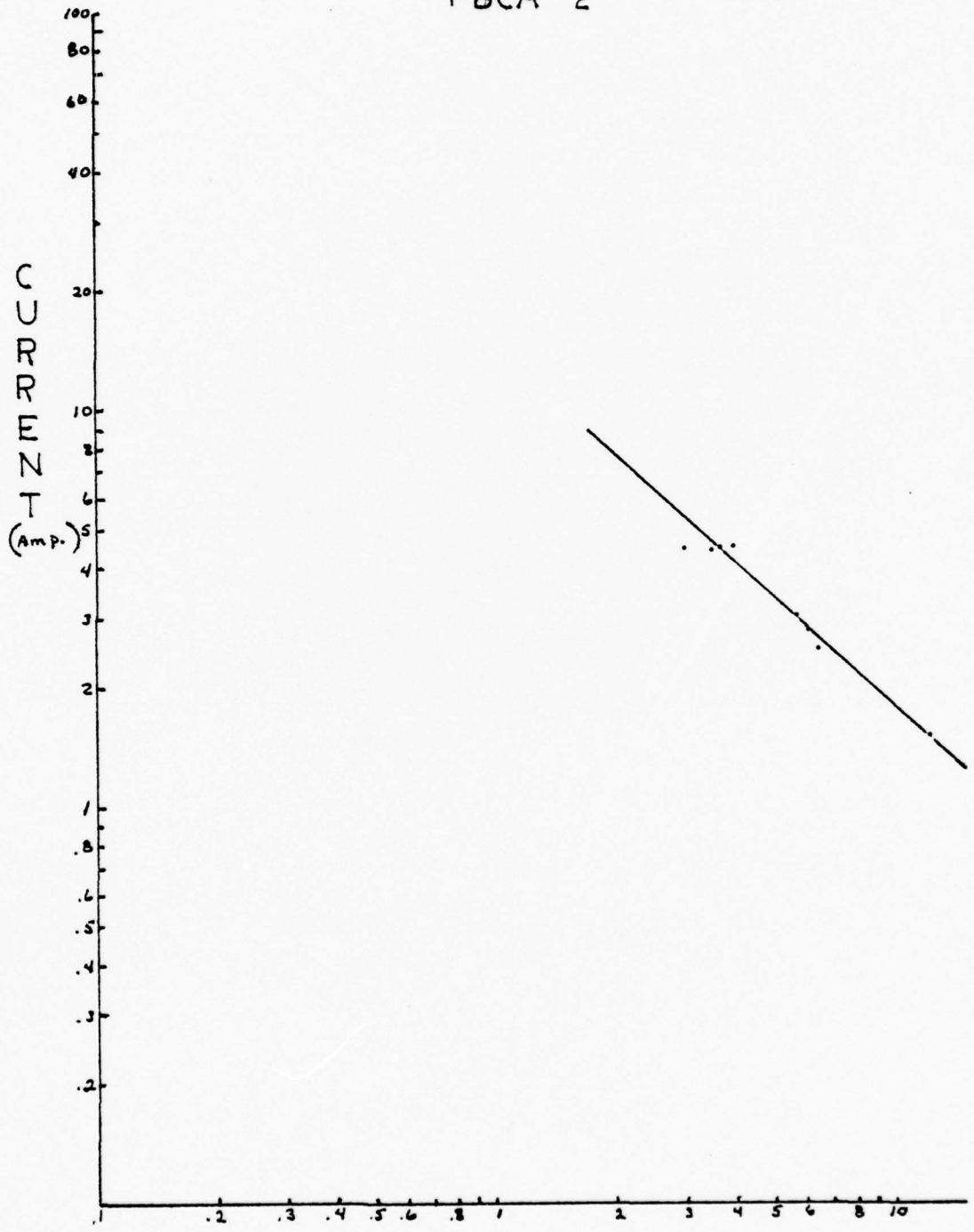

FIGURE 22

of use of 0.46 for the PbSb batteries and 0.38 for the PbCa batteries.

C. OPERATION OF BATTERIES

All cells received an initial charge in accordance with the manufacturer's specifications set forth in Refs. 21, 22, and 23. The antimony cells were filled with 1.235 specific gravity electrolyte and allowed to stand open-circuited for approximately 15 hours. At the end of this stand time the battery was placed on a constant current charge of .0307 amperes per sq inch of positive plate, which corresponds to a .66 ampere constant current charge of the test cells. The calcium cells were filled with 1.255 specific gravity electrolyte and allowed to stand open-circuited for approximately 15 hours. At the end of this stand time they were placed on a constant current charge of .0228 ampere per sq inch of positive plate, which corresponds to a .513 ampere constant current charge for the size of the test cells. Both initial charges were continued at these rates for a minimum of 72 hours. The charge was continued until there was no rise of more than .01 volts in the voltage of the cells over a period of 3-5 hours. At this time the battery had completed its initial charge.

The normal charge given the cell between discharges was a constant potential charge. A constant potential was applied to the battery at the start of charge equal to the TVG voltage of the battery (Table III). The voltage was held constant

until the current decreased to the finishing rate. The current was then held constant and the voltage allowed to rise, at which time the battery was allowed to gas freely. The battery voltage was allowed to increase to a value of between 7.95 and 8.05 volts at which time the charge was secured.

The third type of charge used was an extended charge, referred to as an equalizer charge. This charge was performed after approximately every tenth discharge and as the final charge of the battery before removal from test. The charge was conducted in the same manner as a normal charge, with one modification, namely that the parameters for completion of charge were different. The equalizer charge was continued until there was no rise of the battery voltage for a period of at least one hour. This charge normally obtained values of between 8.1 and 8.15 volts at the end of charge.

The charges were conducted using Hewlett-Packard model 6434B DC power supply during the period of high current demand and a Kepco model CK 18-3 DC power supply at currents below 3 amperes for the completion of charge. Both power supplies were equipped with remote scanning voltage control, so that a constant voltage could be maintained across the battery's terminals, and with current-limiting circuits so constant current could be maintained at the finishing rate.

The discharges were conducted using a controlled current discharge unit built by T. Christian in the Mechanical Engineering Department of the Naval Postgraduate School. A description of this unit can be found in Appendix A. The

current during discharge was held constant, and a minimum limiting battery voltage of approximately 4.6 volts ended the discharge. A Honeywell Electronic 194 two channel strip recorder was used to record the voltage of the total battery and of one cell of the battery. During selected discharges, as a check for positive plate limitation of the batteries, a cadmium reference electrode was placed in the cell so that the negative and positive plate potentials could be monitored during the discharge. A second strip recorder was used to monitor these values. The discharge curves of a typical discharge are shown in Figure 23.

D. ANALYSIS PROCEDURES

1. Sample Preparation

Samples were removed from test at certain intervals during the lifetime of the test battery. At the end of ten cycles, #3 cell was removed from service and replaced by cell #4. Cell #3 was then processed for examination. At the 20 cycle point cell #2 was removed and replaced by cell #5. Cell #2 was then processed for examination. The remaining three cells (1, 5, and 4) were then cycled until failure or cell #1 reached a life of 60 cycles. At this time all three cells were disassembled and processed for examination.

Upon removal from test each cell was thoroughly washed in tap water to remove all electrolyte from the plate. The washing consisted of placing the plate in a beaker of tap water for about two minutes during which time the water was changed three times. The plate was then washed under running

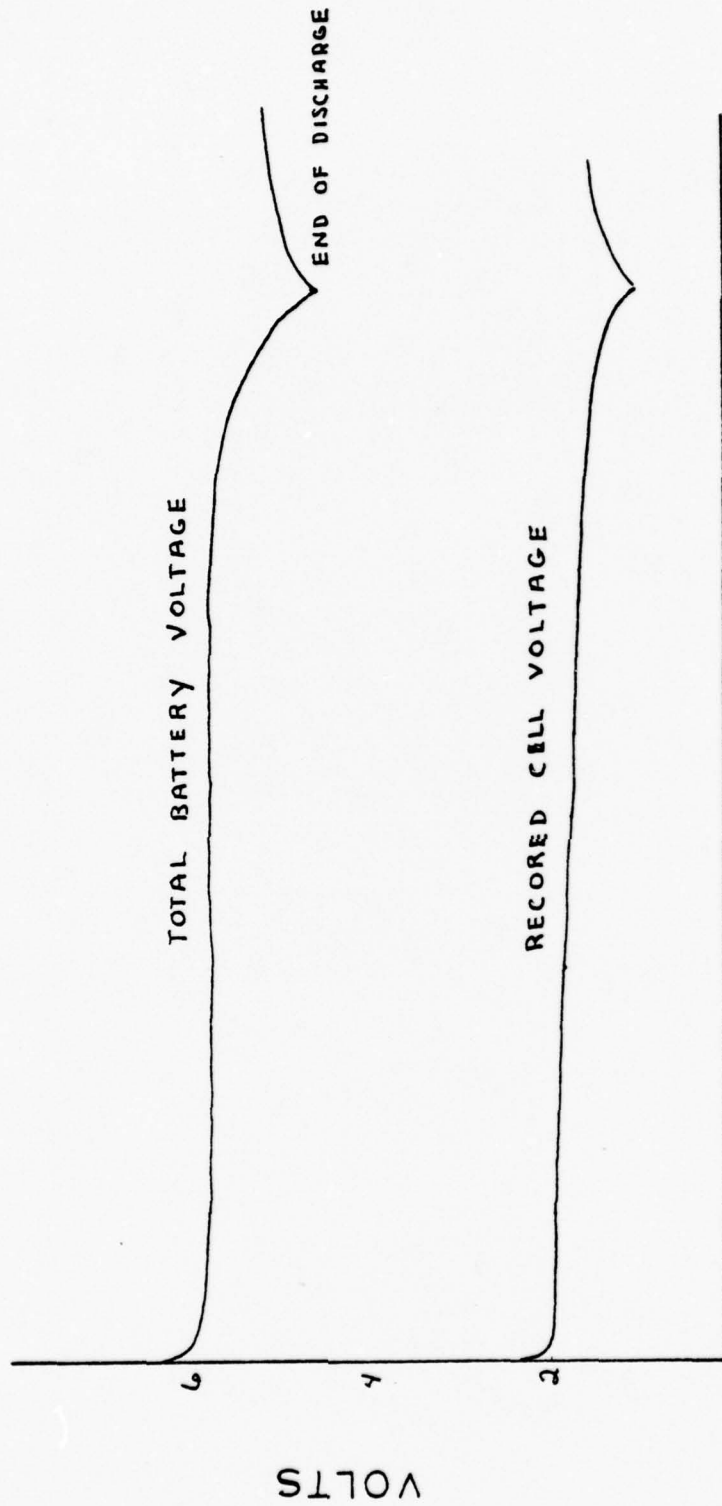

TYPICAL DISCHARGE CURVES FOR TEST BATTERIES

FIGURE 23

tap water for a period of three to five minutes. These wet plates were then placed in an oven at 70°C and dried for approximately 24 hours. When thoroughly dry they were removed from the oven and ready for examination and analysis. The plates were then cut to give a smaller sample for final preparation (Fig. 24).

The final step in sample preparation was the cutting of the plates so exposure of the grid and active material interface be obtained with minimum disturbance to the plate microstructure. Many different attempts and techniques were tried but only three showed any practical results.

The first of these methods was the only cutting method which proved to be of value. A piece of plate approximately one inch square was cut from the plate; (Fig. 24) a grid bar running through the sample was then located and a notch was cut into the grid bar with a single edged razor blade. The cutting of this notch was done under a Bausch and Lomb Model SFB-2 Stereo Zoom Microscope. The cut was made clearly with as little distortion of the interface as possible (Fig. 25). This was the only method which created a useful cross-sectional view of the corrosion layer near the grid surface.

The second method was a simple separation method. A piece of plate with a grid bar located on one side is separated from this grid bar by pulling the grid bar away from the active material as seen in Figure 26.

The third method used to expose the microstructure of the active material, giving a view across the thickness

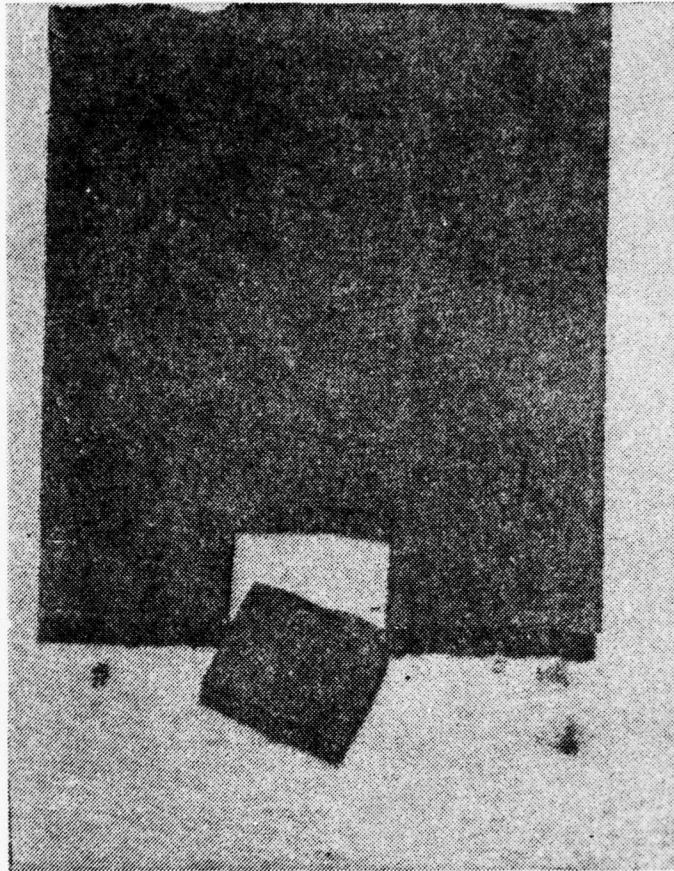

Figure 24. Removal of a section of battery plate for preparation of samples.

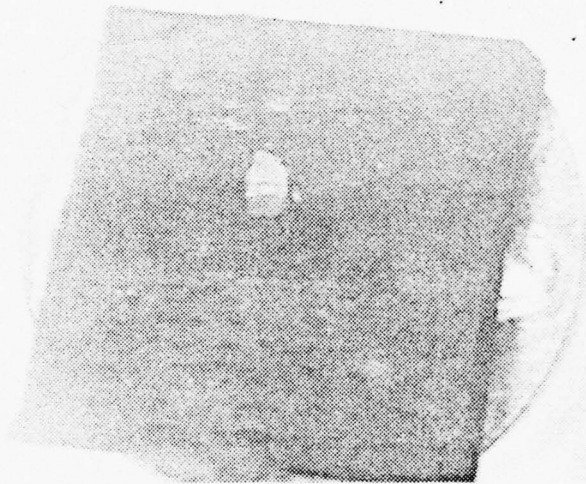

Figure 25. The notched razor cut sample.

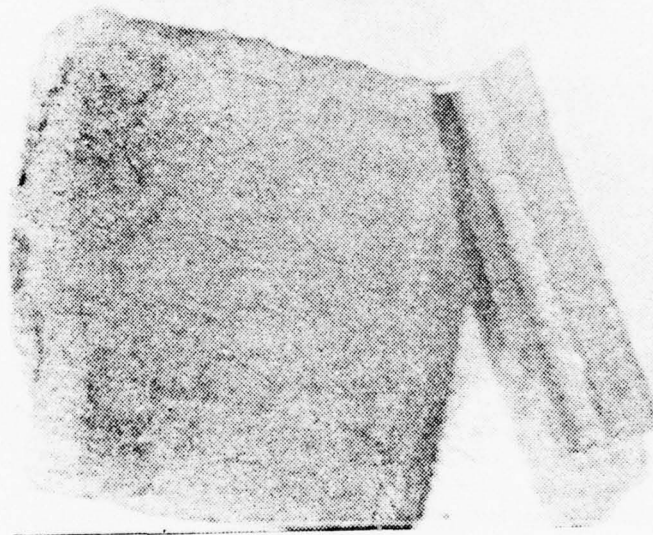

Figure 26. The two surfaces of the separation sample.

of the plate, was a fracture method. A pellet of active material was removed from the grid of the plate, then broken in half and mounted to observe the fractured surface (Fig. 27).

2. SEM Analysis

The examination of these samples was conducted using a Cambridge S4-10 Stereoscan Scanning Electron Microscope (SEM) (Fig. 28). The SEM is a relatively new instrument, developed in the 1960's. There are two significant advantages to the use of the scanning electron microscopy over light or transmission electron microscopy. The first is the ease of sample preparation. The SEM requires little or no preparation other than mounting on a stub. The second advantage is that the depth-of-field is greatly increased over that for a light microscope.

The instrument uses a fine probe of electrons to examine the microtopography of solid bulk specimens. It enables the examination of surfaces whose roughness or other characteristics render their observation extremely difficult or impossible by means of a conventional transmission electron microscope, using either direct or extraction replica methods. The ability to resolve specimen detail is always better than 10 nm under satisfactory conditions, with a depth of focus that is at least 300 times greater than that of a light microscope, when both types of microscope are adjusted for optimum performance and similar picture quality. The Stereoscan has a direct-reading magnification system which



Figure 27. Fracture type sample of active material.

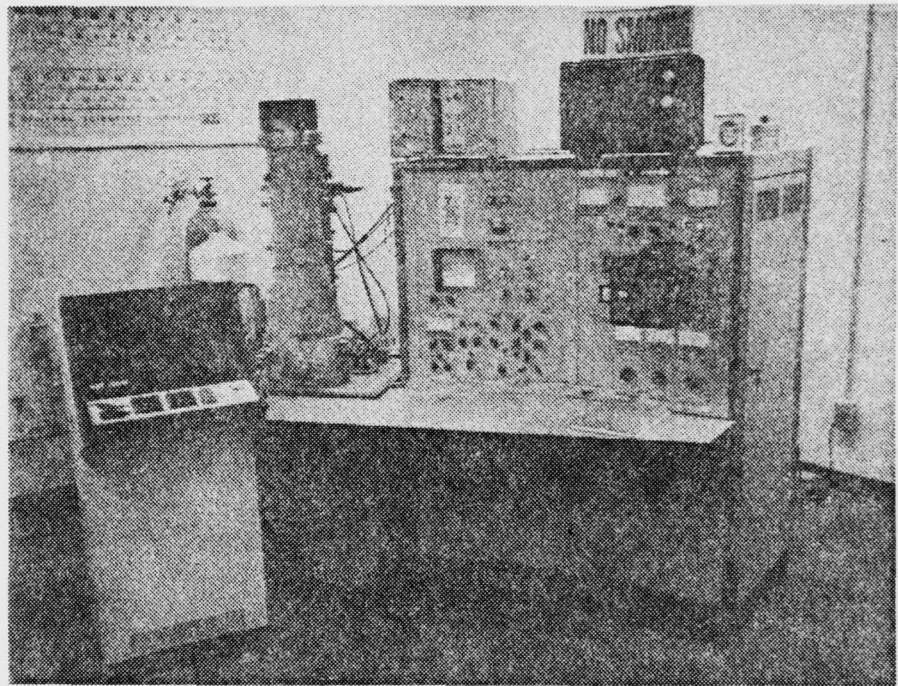

Figure 28. Cambridge Mode S4-10 scanning electron microscope (SEM).

provides a useful range between X20 and X100,000, corresponding to scanned areas of 5 mm to 2 μ m square on the specimen. The standard specimen stage allows objects of up to 12 mm in diameter and several millimeters thick to be manipulated in any required orientation [24].

The specimens are mounted on a small circular aluminum stub. The sample is attached to this stub using silver conducting paint.

Pictures on the SEM were taken using a Tektronik Oscilloscope Camera model C-27 equipped with a Polaroid 545 film holder and type 55/Positive-Negative Polaroid film.

3. X-ray Diffraction

X-ray diffraction patterns were obtained on samples, taken from various cycle life points, of the active material of the positive plate. The equipment used consisted of a Norelco water cooled X-ray diffraction unit fitted with a wide range goniometer and coupled to a Norelco Data Control and Processor unit (Figure 29). The preparation of samples for X-ray diffraction was straightforward. The material to be analyzed was powdered and placed in a standard specimen holder in the goniometer. The patterns were run from 10° through 110° of arc. The Hanawalt system for X-ray diffraction analysis was used for identification of the substances.

4. Optical Microscopy

Samples of the positive plate were cold mounted using vacuum impregnation techniques described by A. C. Simon [33]

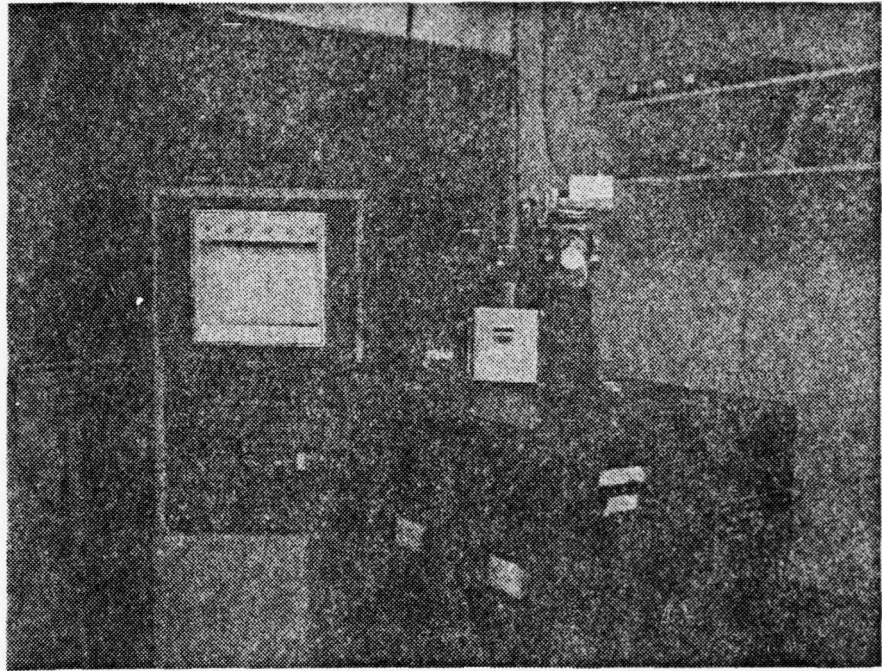

Figure 29. Norelco water cooled X-ray diffraction unit, Wide Range Goniometer and Norelco Data Control and Processor.

for use in the study of the electrochemical processes of the lead-acid battery system. After mounting, the samples were dry polished for observation. Observations were performed on a Bausch-Lomb Dynazoom Bench Metallograph model 32. Polaroid film type 105/Positive-Negative was used in this work.

III. EXPERIMENTAL RESULTS AND DISCUSSION

A. BATTERY PERFORMANCE

The prime measurement of a battery's performance is its ability to maintain a certain constant current for a specified duration of time. The batteries in this investigation were discharged by holding the current constant until a set cutoff voltage range was reached. The time, current and battery voltage of the discharge were recorded. A cycle history was maintained on all batteries tested. These cycle histories of the different test batteries can be found in Appendices B, C, D, and E.

Two antimony and two calcium batteries were subjected to the deep cycle routine described earlier. The antimony grid alloy type batteries were designated PbSb#1 and PbSb#2, and the calcium grid alloy type were designated PbCa#1 and PbCa#2. A decrease in capacity below 80 percent of the value set by Peukert's equation for that battery was taken as evidence of its having concluded its service life and in this way failure was arbitrarily defined to have occurred.

All batteries cycled in the specified cycle routine experienced a similar occurrence at the time of replacement of one cell with a new cell. Following cell replacement, the capacity of the battery initially decreased, with eventually a gradual increase as cycling progressed. This is consistent

with the fact that the new cell had received no conditioning discharges to build up its capacity to 100 percent. Therefore, as the new cell conditioned themselves on the routine the battery's capacity increased.

No one cell was the limiting cell for all discharges of a given battery. A cell was considered to limit the discharge if its end of discharge voltage was less than one-third of the total battery voltage at end of discharge as recorded by the strip chart recorder. The typical curves of a limiting cell and a non limiting cell are shown in Figures 30, 31. Although all plates were cut from the same full size submarine plate, differences in grid size effected which cell was the limiting cell. Where the grid bars were large, less active material was available for reaction, so the cell with oversize grids, thus having less active material tended to be the limiting cell as the test routine was in its first cycles. Typically, near the conclusion of the life of the battery cell one, the oldest cell became the limiting cell.

The specific gravity readings for a typical six hour discharge dropped an average of 40 points in both types of test batteries. This is much less than that experienced in a full size submarine, where they are on the order of 225 points. In order to insure positive plate limitation of the discharge, the test cells were purposely loaded with an excess of electrolyte. An average TLX-39B submarine battery has an electrolyte to positive active material ratio of 2.5 ml/cm^3 while the present test cells had over 10 ml/cm^3 . For this

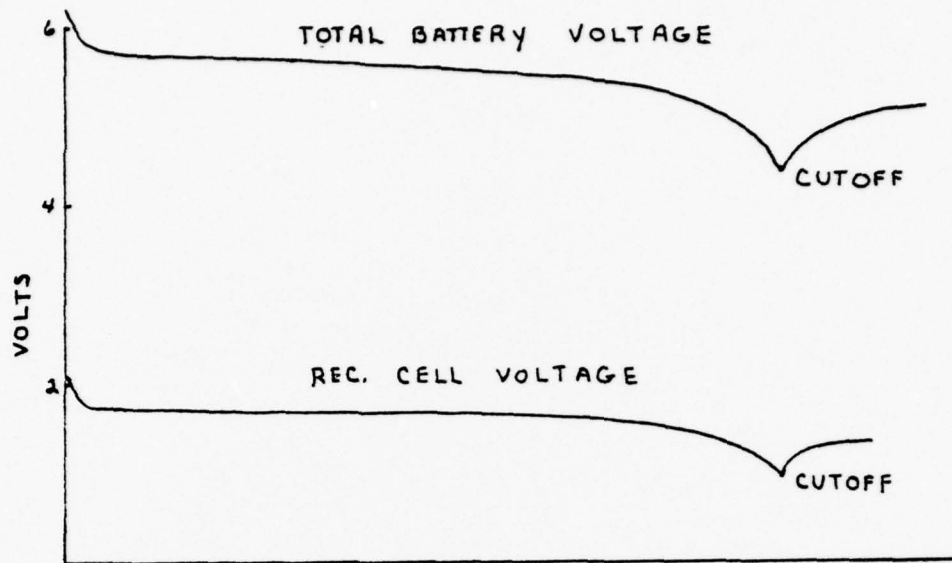

TIME
LIMITING CELL DISCHARGE CURVES

FIGURE 30

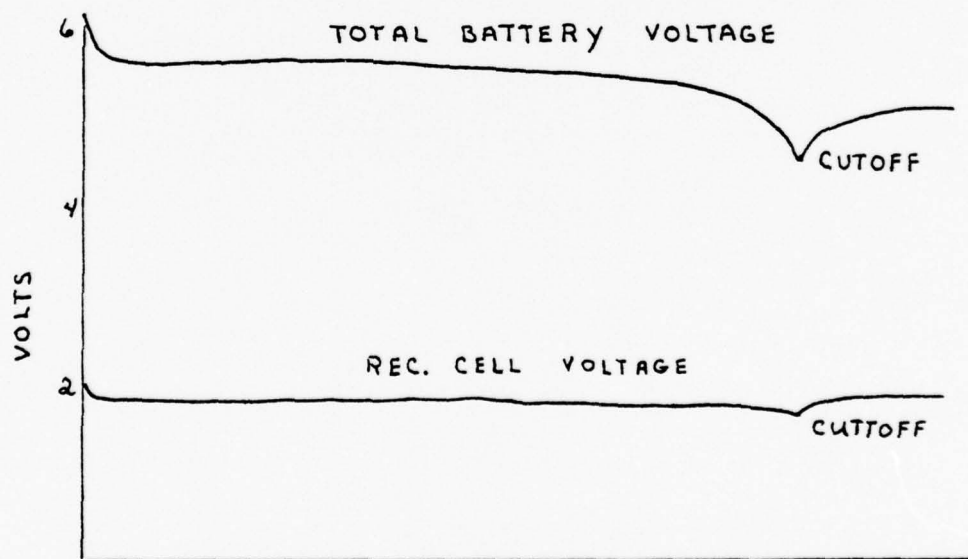

TIME
NONLIMITING CELL DISCHARGE CURVES

FIGURE 31

reason the specific gravity drops during discharge were less than in a full size cell.

The first battery to be run on the deep cycle routine previously discussed was PbSb#1. A plot of the capacity versus cycles is given in Figure 32. This plot illustrates the decrease of capacity after the replacement of one cell with a new one, which occurred in this case at ten and 20 cycles. Cell five of this battery seemed to take an unusually long time to condition. This is attributed to an equipment malfunction on the first two discharges after being placed in the battery. This cell was limiting cell, as expected, but was allowed to discharge more deeply than intended causing the extension of its conditioning time. Cell one became the limiting cell of the battery at about 38 cycles. From this time until end of test, a continual loss of capacity of the battery was noted. Failure was almost complete at 41 cycles so an equalizer charge was given the battery at this time and some of the lost capacity was regained. At 45 cycles failure was complete and cell one appeared to be the cause of this failure. The failure was attributed to "worn out" positive plate material. Worn out plates are ordinarily detected by a decrease in capacity of a battery which is receiving adequate charge. The specific gravity of the electrolyte may rise to the customary value, but the capacity on discharge is below normal [1]. Cell #1 showed both of these symptoms: (1) the specific gravity of cell one returned to normal after a charge was given and

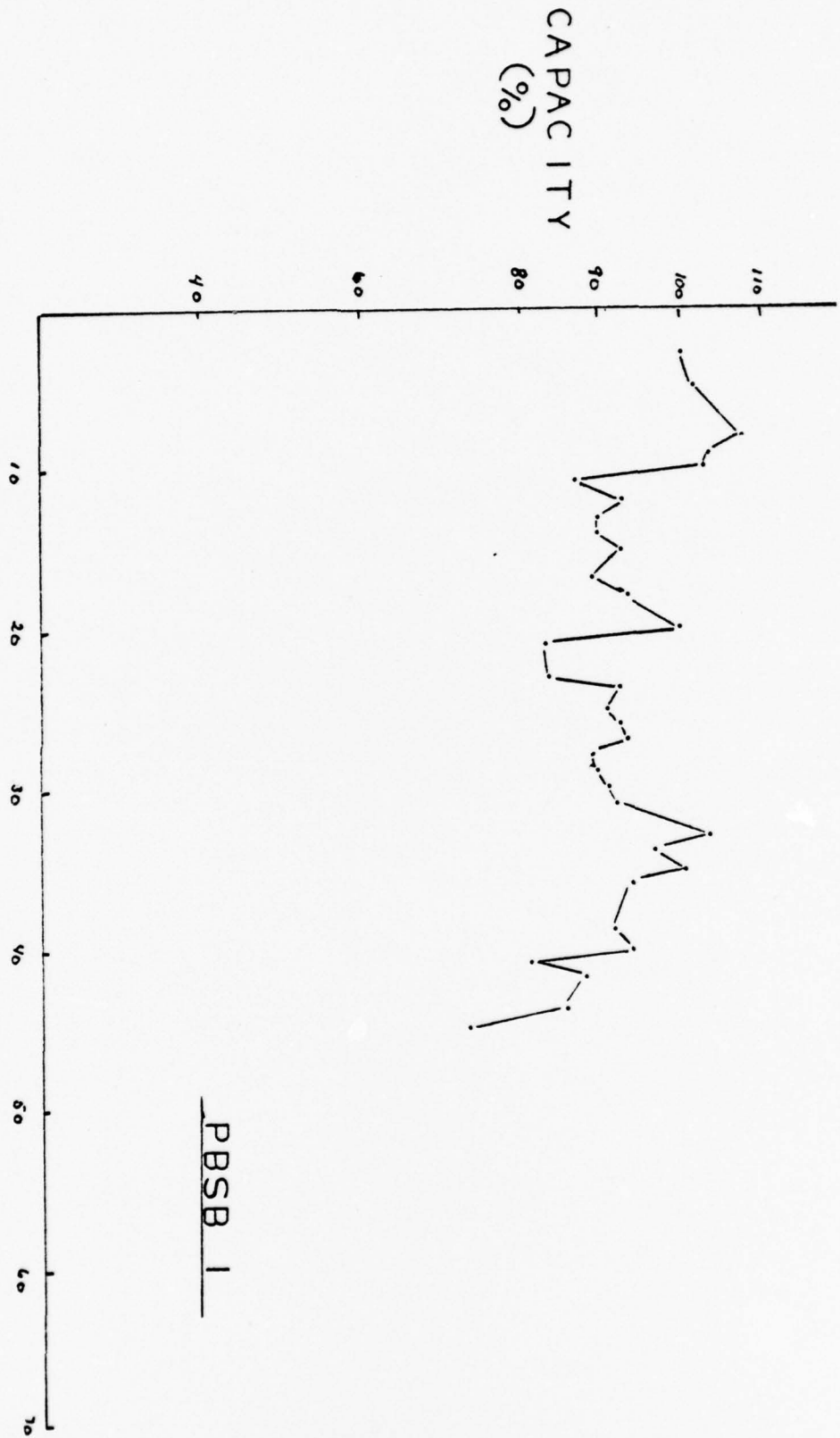

CYCLE
FIGURE 32

(2) that cell one being the limiting cell controlled the capacity of the battery which declined below 80 percent.

A second lead-antimony battery was then placed on the cycle routine. A plot of PbSb#2's capacity versus cycles is given in Figure 33. This battery developed a greater capacity than PbSb#1. This high capacity and the increased lifetime of this battery over that of PbSb#1 due to minor refinements in the testing procedures used on the two different batteries, but still many similarities existed between its history and that of PbSb#1. The limiting cell at the early lifetime was normally the newest cell in the battery. Again cell one, the oldest cell of the battery, became the limiting cell and when this occurred it again signaled a gradual decrease in the capacity of the battery until ultimate failure. Failure of this battery occurred at cycle 55. At this time an attempt was made to recover lost capacity by giving the battery an equalizing charge. Some recovery was attained, but complete failure was confirmed at 60 cycles, and the battery was removed from test. An additional failure mechanism was noted after disassembly of cell one and cell four of this test battery. Both cells showed grid failure, which is considered to have had a significant effect on failure of the battery.

The third battery tested was a lead-calcium type battery designated PbCa #1. The capacity versus cycles plot of this battery is given in Figure 34. This battery did not experience failure during the period of test but a definite trend

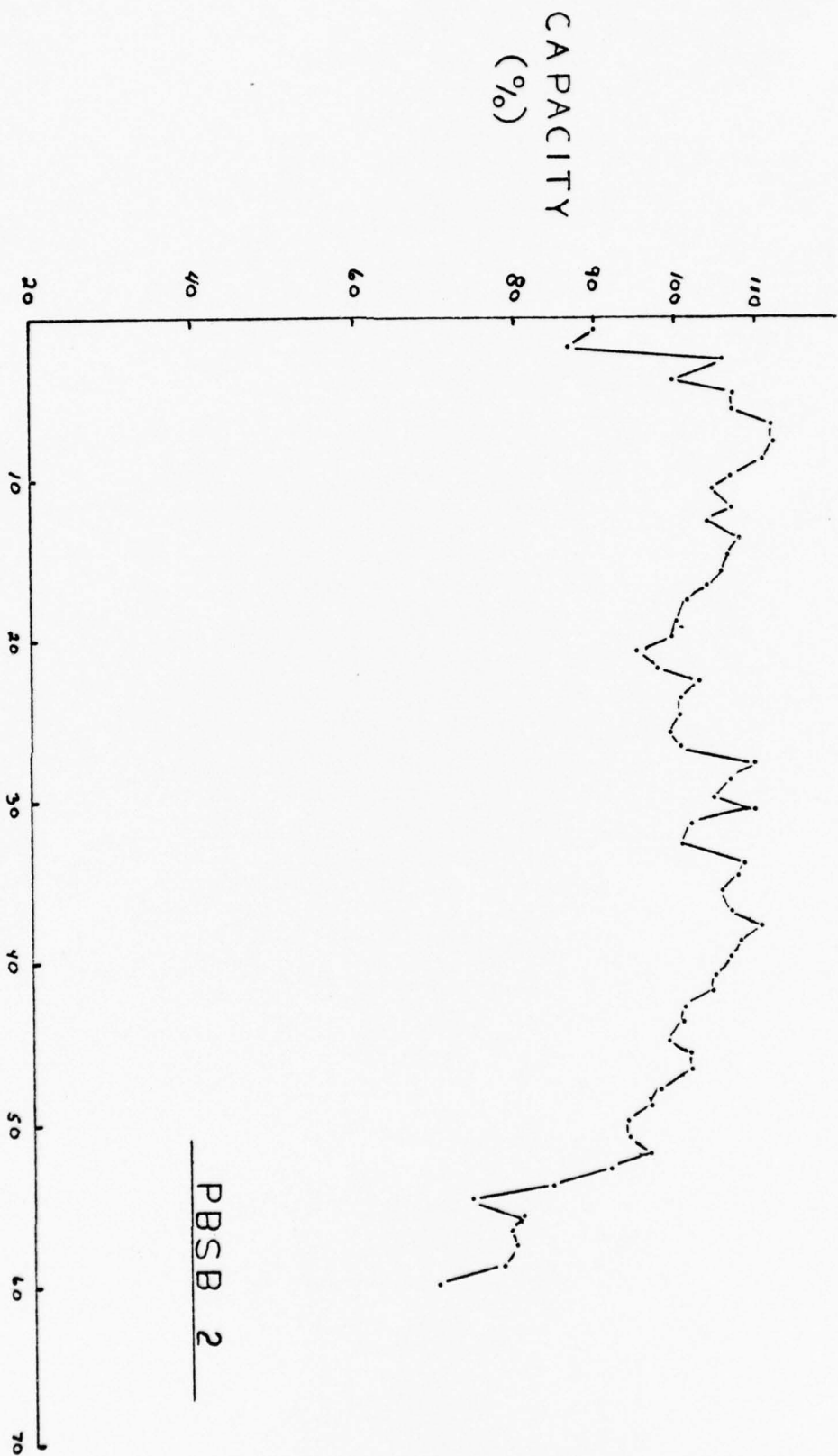

CYCLE
FIGURE 33

PBSB 2

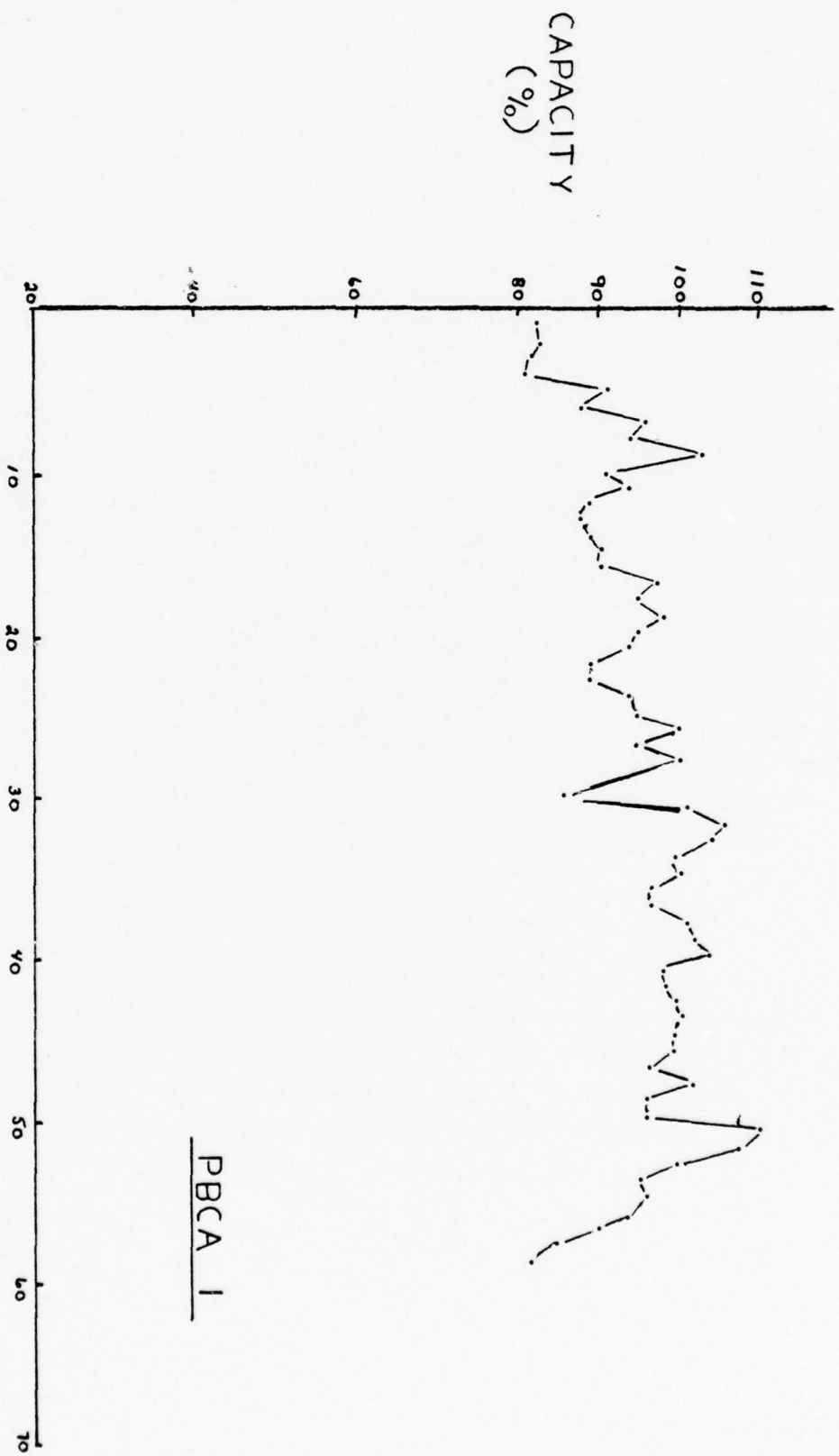

CYCLE
FIGURE 34

PBCA 1

involving a decrease in capacity was evident at the time the cycle routine was concluded. Again it was seen that the limiting cell of the battery tended to be the newest cell at the outset of the test routine. A point was reached, at approximately 15 cycles after final cell replacement, or 35 cycles of test, where cell one again became the limiting cell. This characteristic is believed to be a peculiarity of these test cells, where the cells have different cycle times. In an on-service battery all cells would have the same number of cycles and this characteristic would not exist. The phenomenon of the oldest becoming the limiting cell, took place at 35 cycles for PbCa#1, where cell one became the limiting cell. For PbCa#1 the occurrence was not followed by a corresponding gradual decrease in capacity, as observed in the antimony type batteries; the decrease in battery capacity did not begin until after an equalizing charge at cycle 50. At cycle 55 cell one began to show the signs of "worn-out" plates. The battery was removed from test at 60 cycles and prepared for examination.

The last battery tested was a lead-calcium type designated PbCa#2. An additional purpose of this battery was to ascertain the effect of the inadvertent reversed placement of the separators in the other batteries, i.e., flat side toward the positive plate with fiberglass mats between. The cycle routine was conducted for a full 20 cycles to allow sufficient time for conditioning of the cells. No cell was removed from the battery at 10 cycles. All cells reached capacity of above

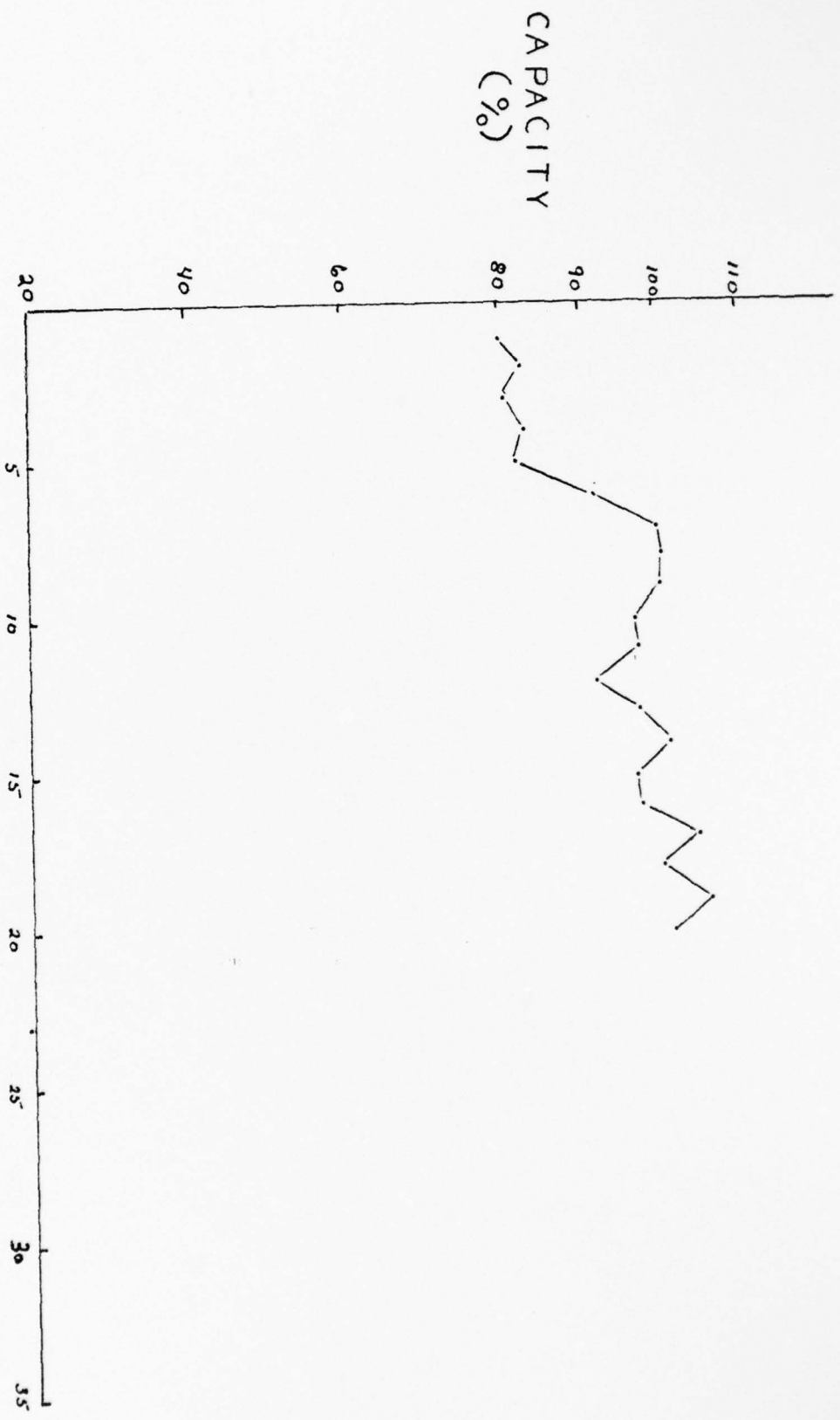

FIGURE 35

100 percent. The ampere-hour capacity of this battery was approximately 16.8 amp-hrs at 4.5 amps as compared with 16.65 amp-hrs for PbCa#1. Therefore it was concluded that this separator reversal in no way prejudiced the results obtained from these tests. A plot of capacity versus cycles for PbCa#2 is given in Figure 35.

B. OBSERVATIONS WITH SCANNING ELECTRON MICROSCOPY

Samples for microscopic examination were removed from all positive plates which were cycled in accordance with the test routine procedures already discussed. Samples examined of the lead-antimony type were obtained from PbSb#1 at 10, 20, 25, 35, and 45 cycles and from PbSb#2 at 10, 20, 40, 50, and 60 cycles. Samples examined for the lead-calcium type were obtained from PbCa #1 at 10, 20, 40, 50 and 60. Remembering that all plates were removed from test in the fully charged condition, the following history of morphological changes over the course of the tests was constructed.

1. Changes Observed in the Lead-Antimony Type Batteries

A macroscopic view of the lead-antimony positive plate in the zero cycle condition is shown in Figure 36. The plate appears to have an even texture, almost smooth. The active material is firm, reddish brown in color, similar to the color of rust. After about 40 cycles, a definite change in the macroscopic appearance of the active material was observed. Figure 37 shows the plate as it appeared at this time. The active material had begun to expand away from the smaller of the horizontal grid bars, but remained firmly attached to the

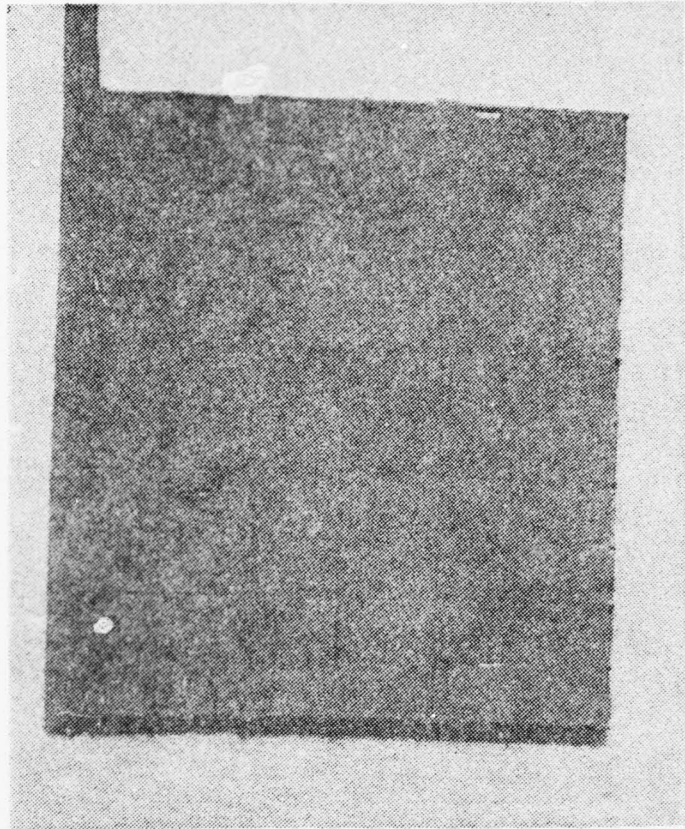

Figure 36. Positive plate of a lead-antimony grid battery at zero cycles showing the smooth texture of the uncycled plate.

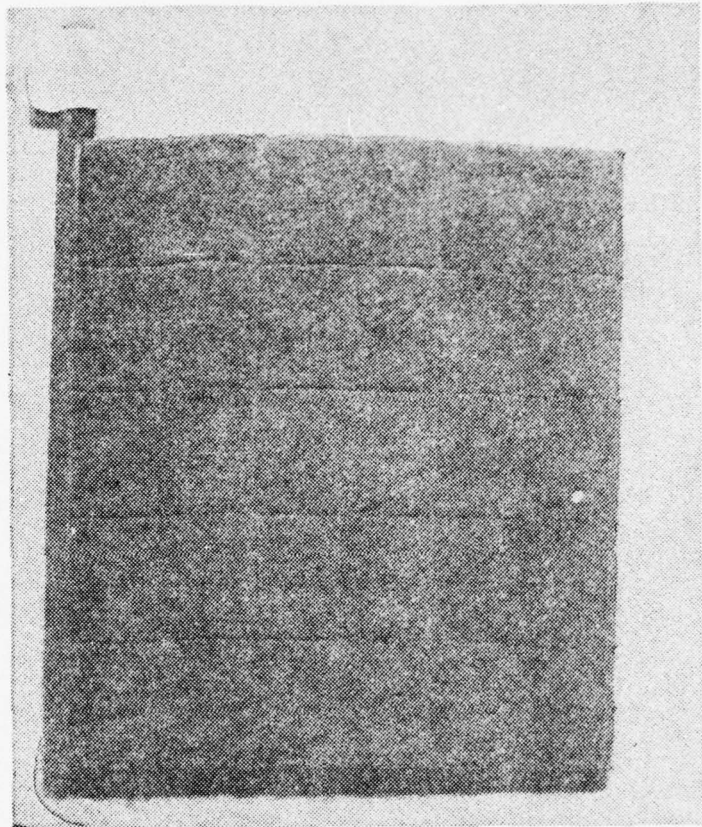

Figure 37. Positive plate of a lead-antimony grid battery at 40 cycles. The first signs of a change in the structure of the plate have occurred.

larger horizontal and vertical grid members. This expansion of the active material is attributed to the growth of a void-filled structure of the active material as cycling progresses, i.e., an increase in the total occupied volume. The relatively smooth appearance of the plate surface has changed to a ruddy crater-like complexion near the bottom, and it was in this area that some shedding of active material is believed to have taken place. After 50 cycles (Fig. 38), the expansion of the material has led to dome-like bulges on the plate, and increased shedding is represented by the cratered texture of the surface. The photo shows the top of these domes to be smoothed over. This was caused by the evolution of drying and storage of the plate before analysis. Upon removal from the cell, these tops exhibited the same crater-like texture seen throughout the plates surface. Grid failure was also evident on the outer grid of this plate, and can be seen in the lower left hand corner of the photograph. This type of grid failure is common in lead-antimony grids at the end of battery plate life. The location of this failure suggests that failure is caused by stress corrosion of the grid material, such as described by Simon [25]. At 60 cycles the dome-like structures seemed to have collapsed back into the plate and increased shedding had occurred in conjunction with this. Unique to this plate, and considered to be the prime cause of failure, is structural failure of the grid. This resulted in isolation of vast amounts of active material throughout the plate. The pencil in Figure 39 shows the location of this

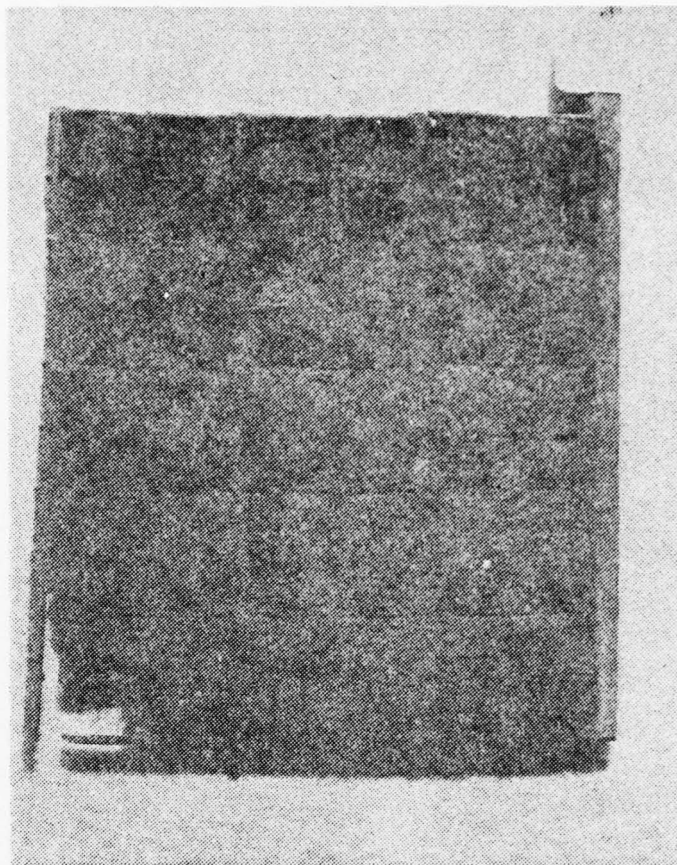

Figure 38. Positive plate of a lead-antimony grid battery at 50 cycles. The dome-like bulges are evident at the surface. The grid failure of this plate can be seen.

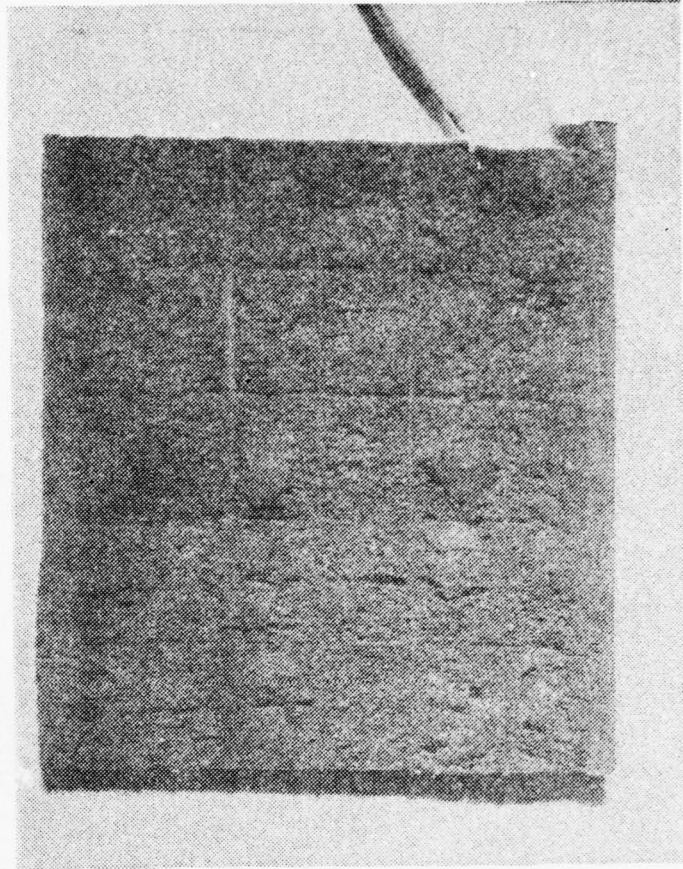

Figure 39. Positive plate of a lead-antimony grid battery after 60 cycles. A crack exists through approximately 80 percent of the plate.

crack. Numbering the horizontal grid bars from top to bottom, this crack extended from bar one through seven, with a crack at the bottom through grid bar 11. All current to and from the active material therefore had to be passed through bars eight, nine and ten, and the resultant lengthening of current paths had a direct detrimental effect on the performance and microstructure of this cell.

The SEM observations of the zero cycle lead-antimony plates shows active material in the form of small spheroidal shapes firmly bonded together to form a continuous mass of active material (Fig. 40). It appears as a highly porous mass of similar sized agglomerates randomly arranged to present a high relative surface area to the electrolyte at lower magnifications (Fig. 41). Between the grid and the active material is a corrosion layer (Fig. 42), created during formation, which measured approximately 30 μm thick at this point, a fact that was confirmed by the use of optical microscopy (Fig. 43). The attachment of the active material to the grid surface through this corrosion layer appears as an almost liquid-like entrapment of the active material within the corrosion product layer (Fig. 44).

After 10 cycles on the deep cycle test routine no change in the structure of the active material near the grid had taken place. The same sort of active material structure noted still exists as seen in Figure 45. However the corrosion layers of the grid has increased its size to about 55 μm (Fig. 46). This corrosion layer is thought to be the mixture

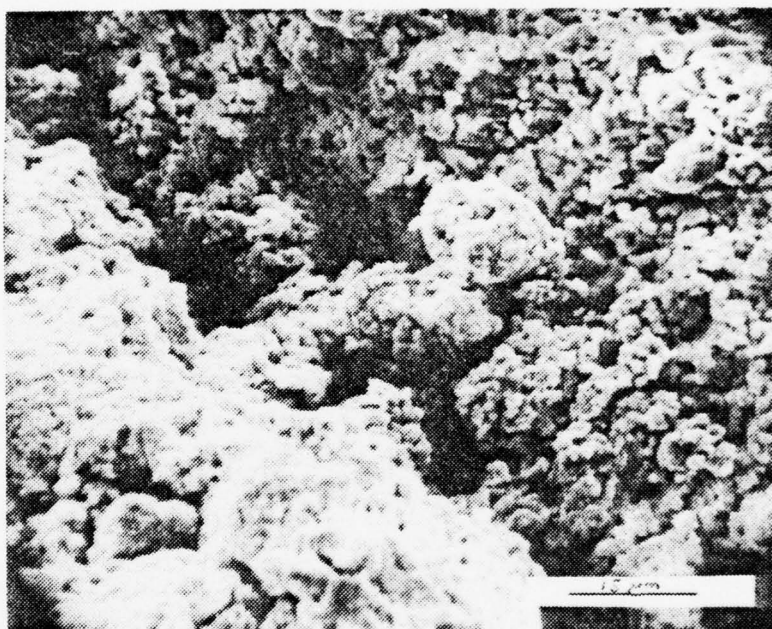

Figure 40. Active material of a zero cycle lead-antimony alloy grid battery near the grid, 1200X.

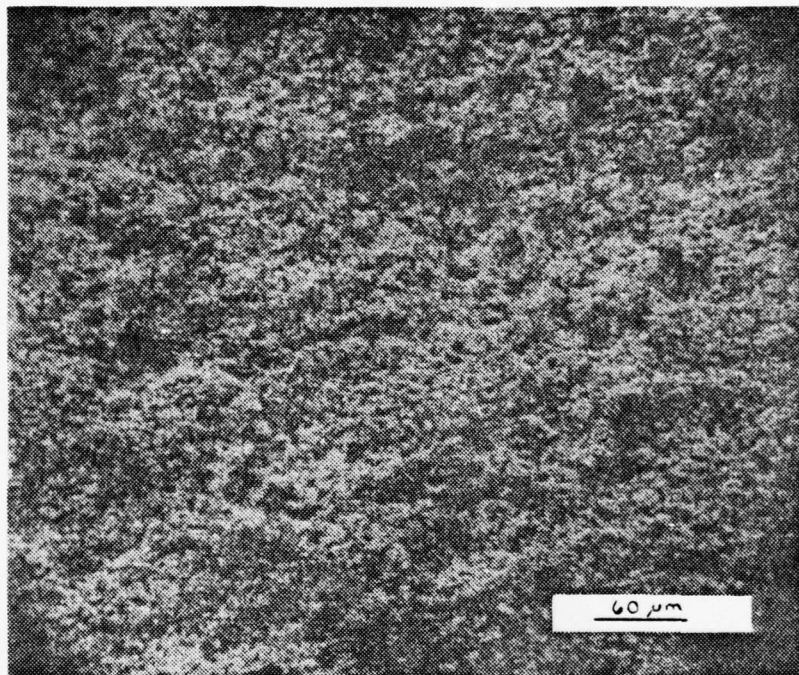

Figure 41. Active material of a zero cycle lead-antimony alloy grid battery attached to the grid, 230X.

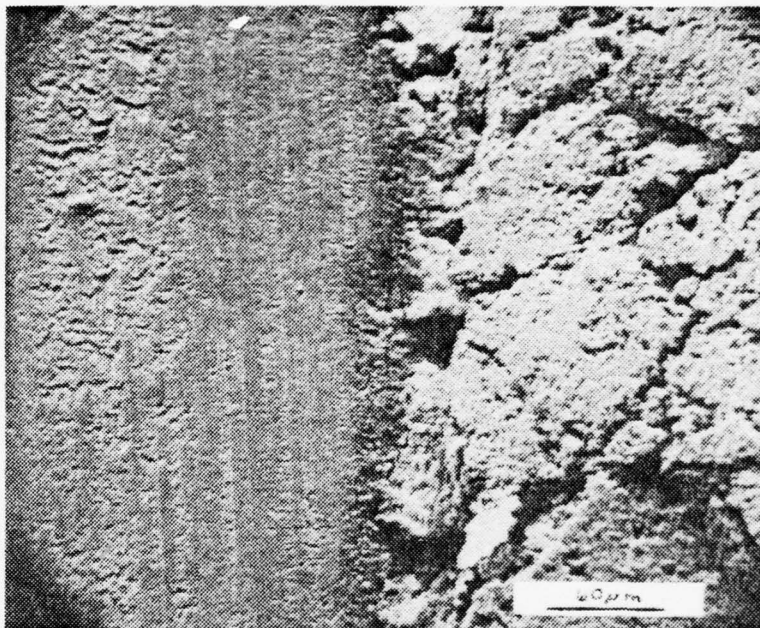

Figure 42. Corrosion layer at the interface between the active material and the grid of a lead-antimony battery, 280X, zero cycle.

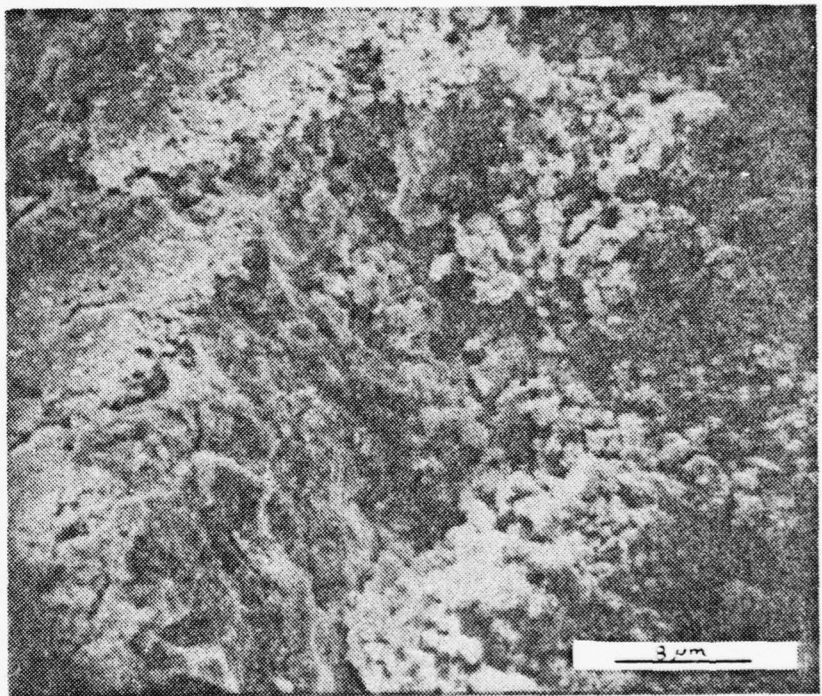

Figure 44. Corrosion-active material interface with partial separation of the active material from the corrosion layer. 2400X lead-antimony type plate.

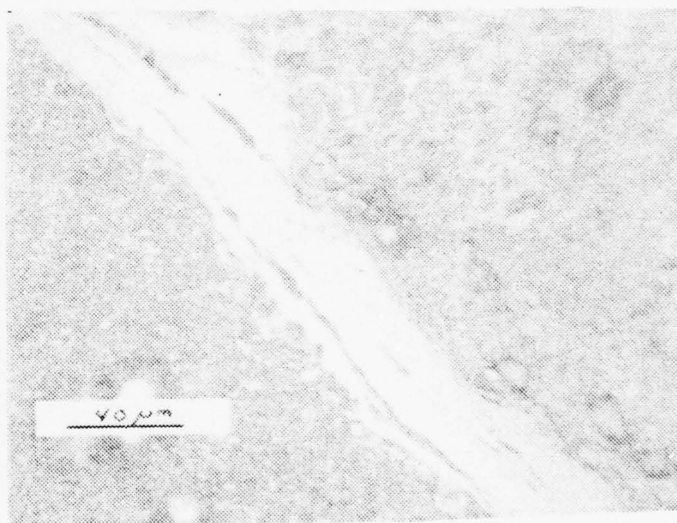

Figure 43. Optical photomicrograph of the corrosion layer of a zero cycle lead-antimony type positive plate 400X.

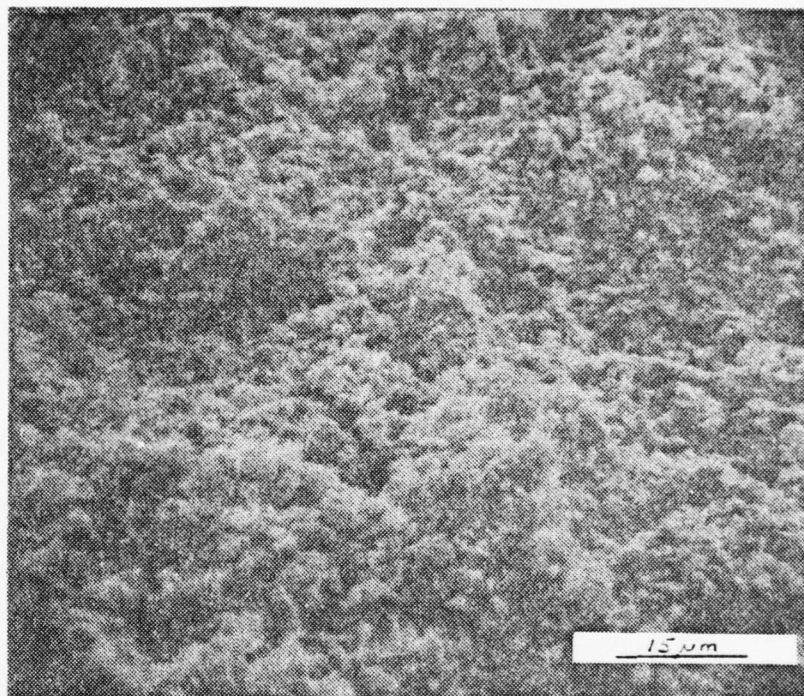

Figure 45. Active material near the grid of a lead-antimony battery after 10 cycles, 1250X.

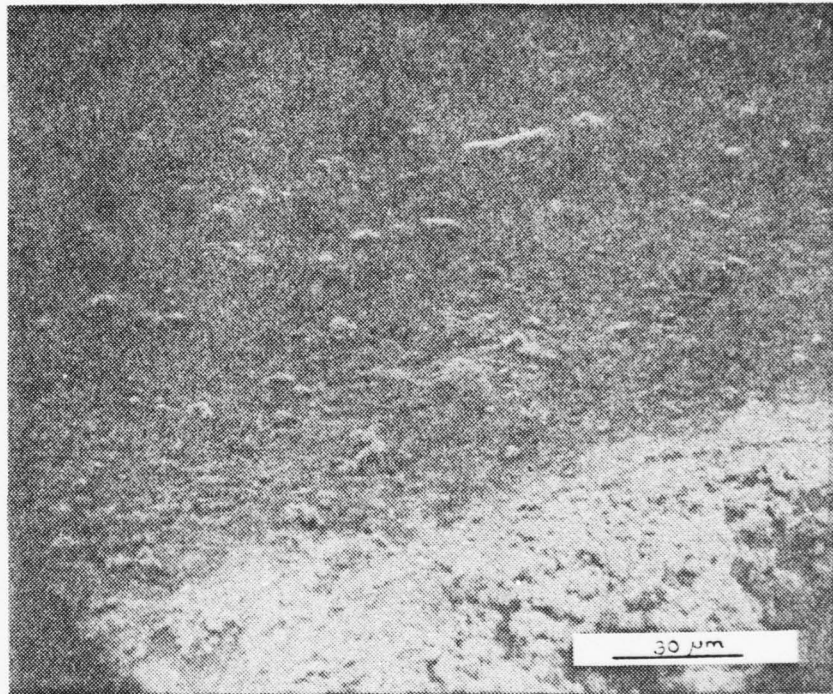

Figure 46. The grid-corrosion-active material of a lead-antimony battery after 10 cycles, 625X.

AD-A033 764

NAVAL POSTGRADUATE SCHOOL MONTEREY CALIF
STUDY OF THE CYCLIC PERFORMANCE OF SUBMARINE TYPE LEAD-ACID STO--ETC(U)
SEP 76 J L POKORNY

F/6 10/3

UNCLASSIFIED

NL

2 OF 3

AD
A033764

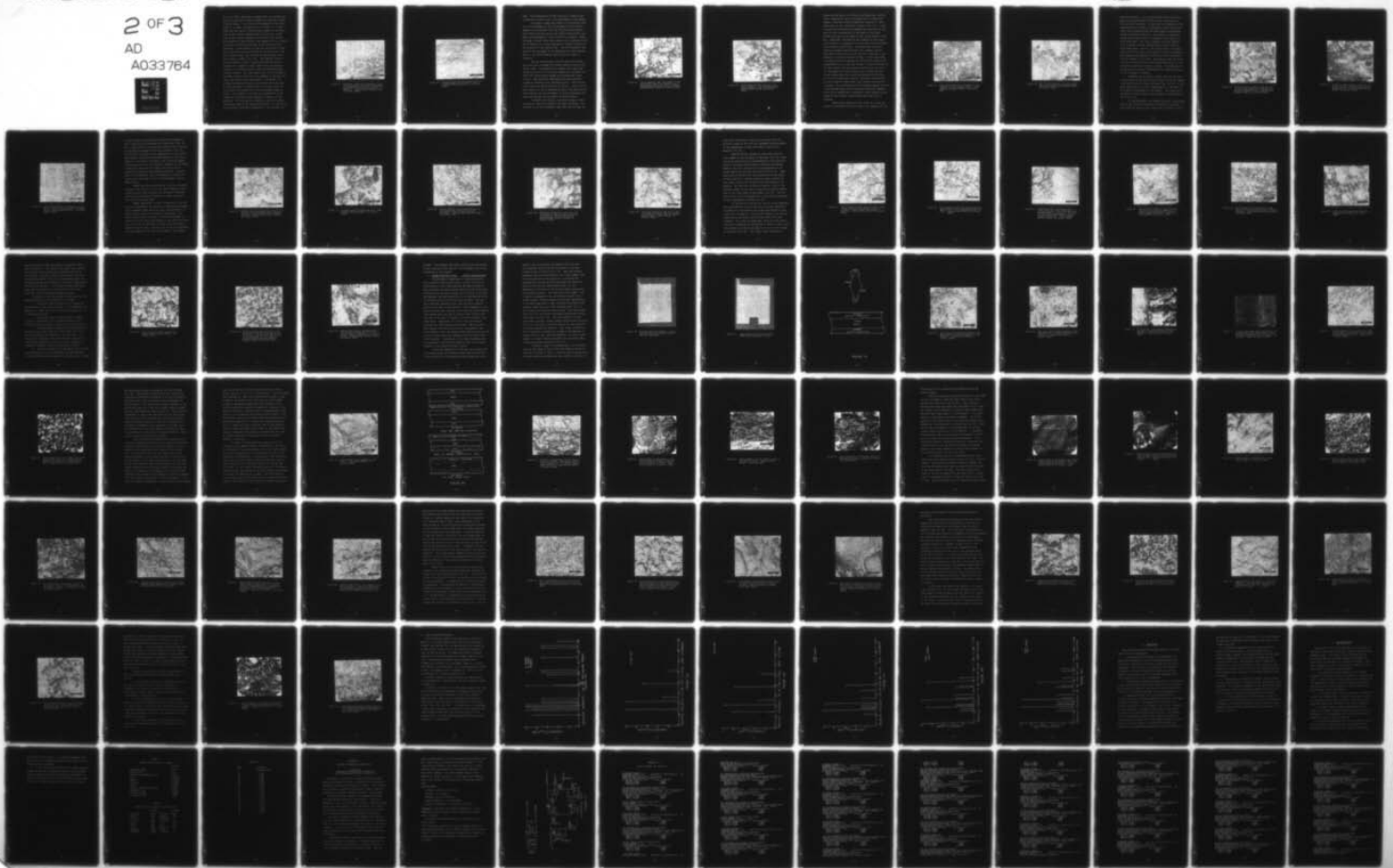

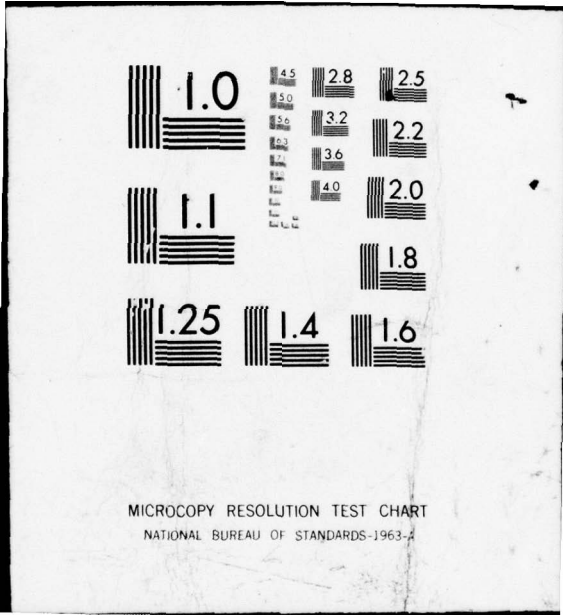

MICROCOPY RESOLUTION TEST CHART
NATIONAL BUREAU OF STANDARDS-1963-A

of α and β PbO_2 , described by Burbank [26] as a layered composite of very small crystals resembling a eutectic crystallization product. The liquid-like entrapment of the active material is shown in greater detail in Figure 47. It was noted that this type of bonding action appears to be favorable to good current conduction back to the grid. Noted also at the interface between the corrosion layer and the active material, the corrosion layer seemed to be in a transition state of possible conversion to the active material structure. In the process of examining one sample, an area was located where the active material had fallen away from the corrosion layer, thus allowing an unobstructed view of this corrosion product (Fig. 48). This exposed corrosion product appeared to have a compacted microporous surface covered with a network of small needle-like structures arranged as to indicate locations where now-converted PbSO_4 crystals existed. This layer seems to be firmly attached to the metal surface of the grid, and attempts to separate this layer from the grid were unsuccessful. The needle-like crystalline network structures are believed to be the same as those described in greater detail by M. Coyle [Ref. 27] in his work with floated and trickle discharged submarine plates. This network is believed to be beneficial to the conduction of current and maintenance of capacity of the batteries. This was the only indication that this network structure existed on the lead-antimony plate. As the cycling of the battery continued no observance of this network was

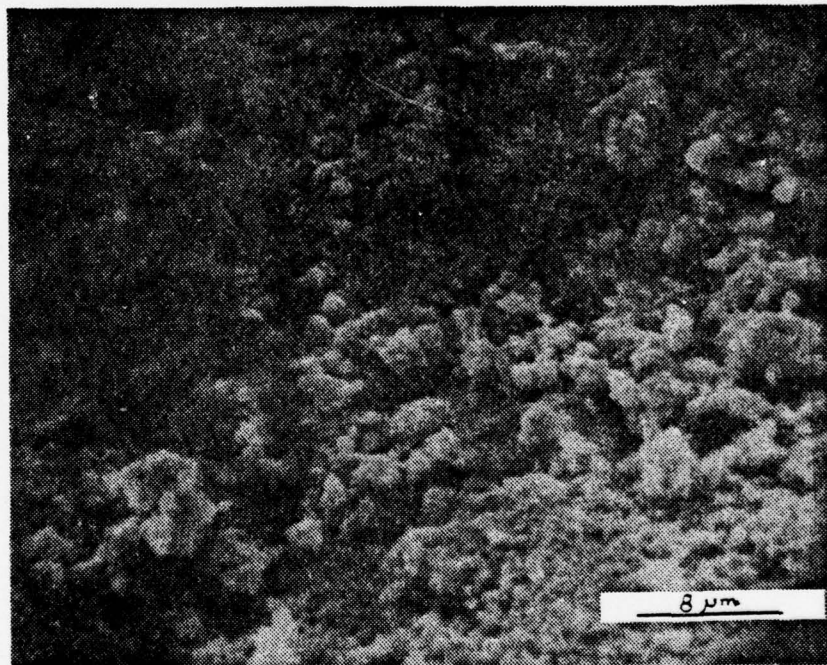

Figure 47. Corrosion layer-active material interface showing the liquid-like entrapment of active material in the surface material. Lead-antimony battery after 10 cycles, 2600X.

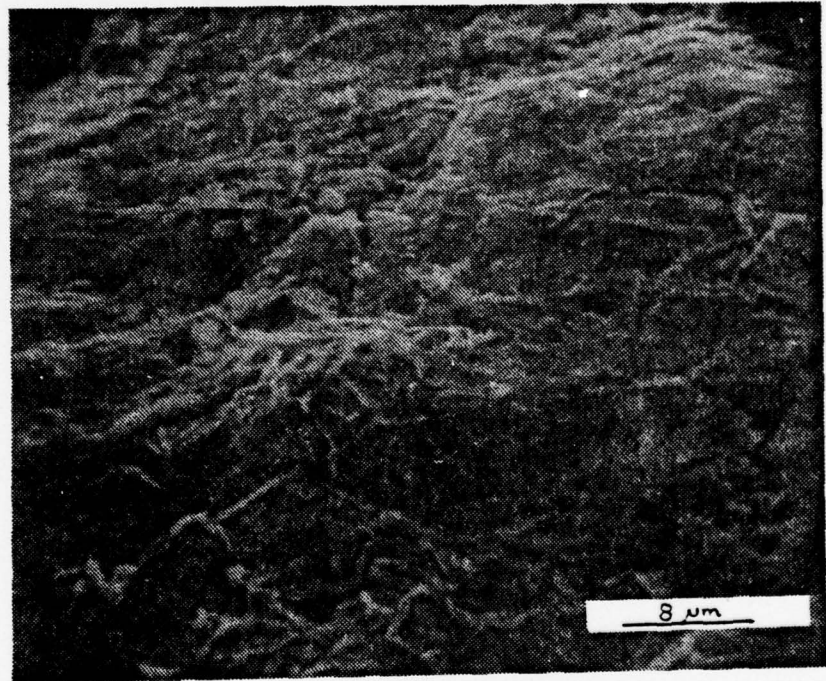

Figure 48. Surface within the corrosion layer of a lead-antimony battery at 10 cycles, 2300X.

made. The disappearance of this structure in these plates is believed to play a role in the performance of the battery.

No further changes were noted in the corrosion layer or in its attachment to the active material at 20 cycles. However it was observed (Fig. 49) that the active material most distant from the grid, at the center of the pellet, had begun the development of voids within its structure. Along the edges of these voids there seemed to be a grouping of the active material, as if some preferential location existed for the formation of the lead-dioxide. The active material near the grid did not appear to be undergoing this same transformation. The active material near the grid is shown in Figure 50.

The two lead antimony batteries PbSb#1 and PbSb#2 from this point on seemed to progress toward failure at different rates. The morphological changes which they experienced during the first 20 cycles appeared to coincide, but after this period PbSb#1 seemed to be accelerated toward failure. Both batteries experienced the same structural changes at different cycle reference points. PbSb#1 failed at 45 cycles and PbSb#2 failed at 55 cycles. There could be many reasons for this difference but one of the major contributing factors was the refinement of cycling procedures and experience gained over the course of testing PbSb#1.

In PbSb#1 at 35 cycles, a distinct change of microstructure of the active material had begun to emerge. The interior of the active material away from the grid, near the

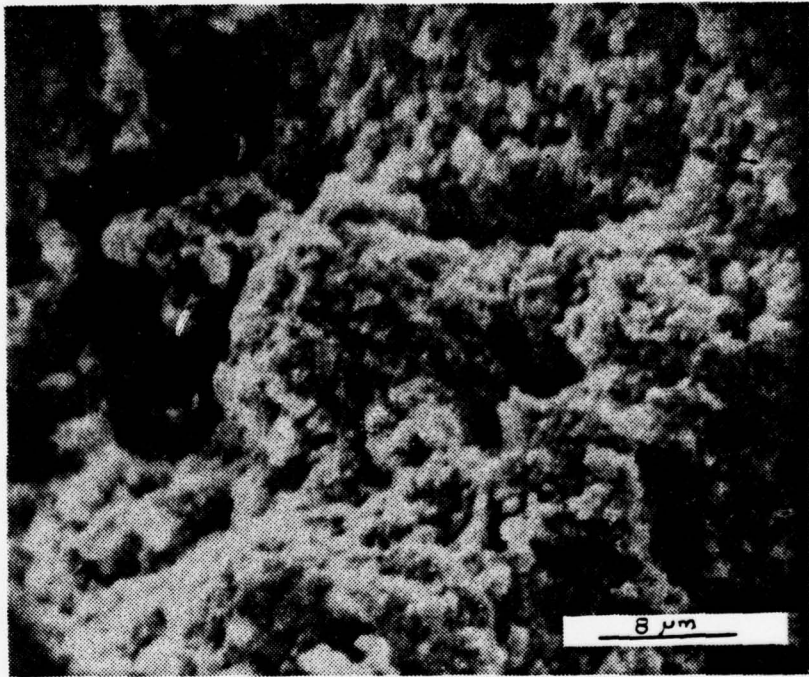

Figure 49. Active material near the center of the pellet with the first stages of void development within the active material. Lead-antimony battery 20 cycles, 2400X.



Figure 50. Active material near the grid with little change in its microstructure. Lead-antimony battery 20 cycles, 1280X.

center and just below its surface, developed large internal voids, separated by nearly continuous walls of PbO_2 which formed a labyrinth structure henceforth referred to, after Simon [32], as the "coralloid" structure (Fig. 51). A similar coralloid structure also appeared near the grid but the scale of this structure was on the order of five times smaller than seen at the center of the active material (Fig. 52). Simon [Ref. 32] explains the formation of this coralloid structure in conjunction with the idea of the existence of an inactive form of PbO_2 . He explains the coralloid structure formation upon the basis of a "memory" pattern that remains from cycle to cycle and that originates in the presence of inactive particles of PbO_2 . As the active PbO_2 is dissolved during discharge the inactive form tends to be concentrated in or on the lead sulfate. On the initiation of the next charge cycle the inactive particles act as nuclei for the growth of the active PbO_2 , and as these PbO_2 particles enlarge they form a more concentrated form of PbO_2 . As this cycle progresses, greater and greater concentration of active material takes place, thus forming the coralloid structure. By a continuation of this charge-discharge cycling a well-defined PbO_2 coralloid structure eventually emerges, which can be repetitively reproduced on each charge cycle by reason of the residual inactive PbO_2 particles which it contains.

Observations made during this study of cycling batteries are consistent with this idea of the formation of the

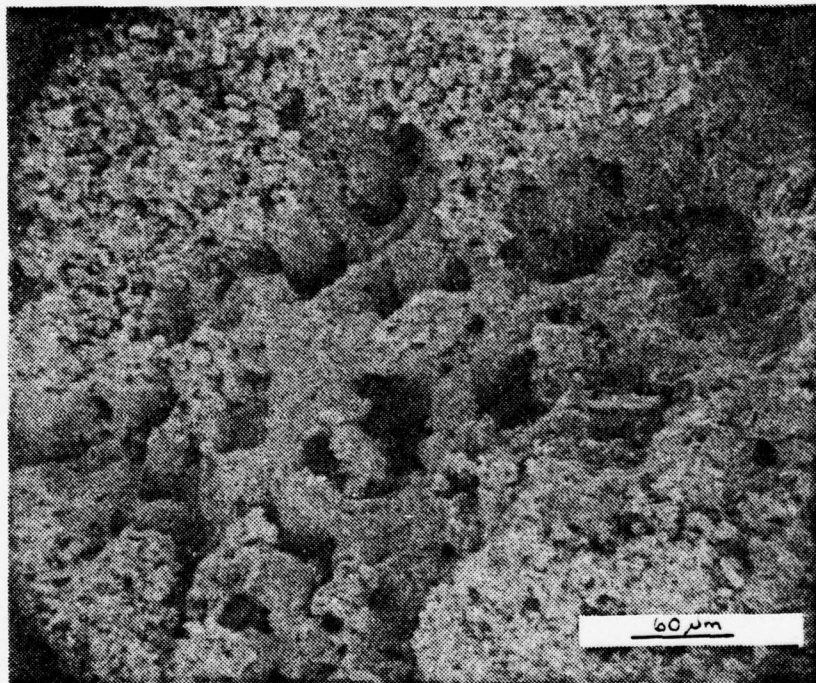

Figure 51. Large scale coralloid structure at the interior of the positive plate. Lead-antimony battery, PbSb#1, 35 cycles, 245X.

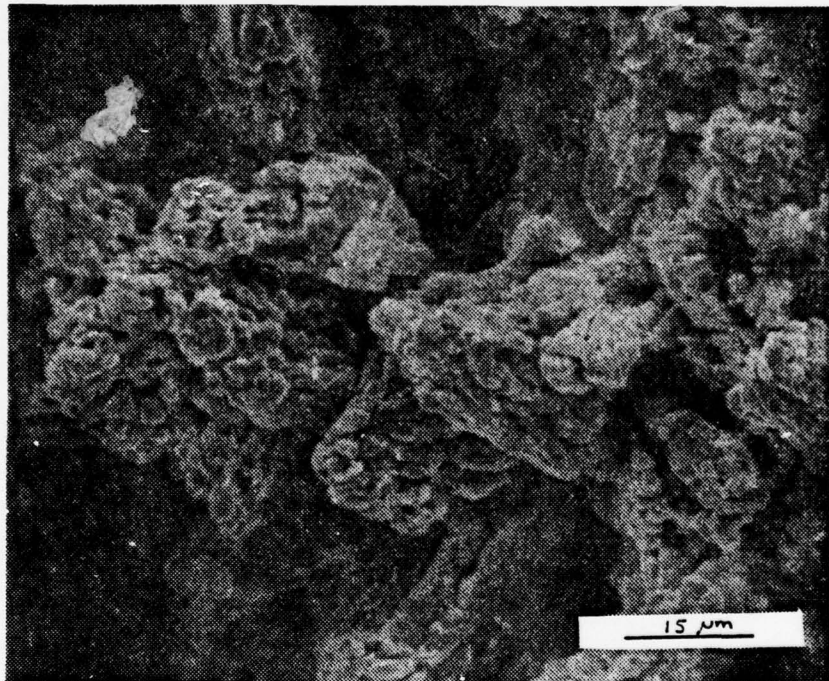

Figure 52. Small scale corallois structure near the grid lead-antimony battery PbSb#1, 35 cycles, 1200X.

coralloid structure. It is also believed that the current paths of the active material play a role in the scale of this coralloid structure. As the voids are produced, and the concentration of the PbO_2 at the edges of these voids takes place, the concentrated lead dioxide becomes a preferential current path back to the grid. The creation of these preferred current paths cause an increased current density to exist along them. This local increase in current density in turn causes a further concentration of active material along these paths, creating even larger voids. The appearance of the first voids at the center of the active material, and subsequent enlargement of the voids in this area tends to lend credence to this idea. Near the grid the void structure has not had the time to form these large voids, so that a smaller coralloid structure is present. The formation of the coralloid structure is believed to be a normal evolution in the lifetime of a battery.

Noted also at 35 cycles of PbSb#1 was the fact that at the surface of the grid corrosion layer, the spiny needle-like crystals could no longer be found (Figs. 53, 54), a fact whose importance is not fully understood but is believed to be related to performance of the battery. Also seen was an increasing of the corrosion layer thickness to approximately $60 \mu m$ (Fig. 55).

By the time PbSb#1 had reached 45 cycles, the development of the coralloid structure was essentially complete. At the surface of the grid the structure had increased in size,

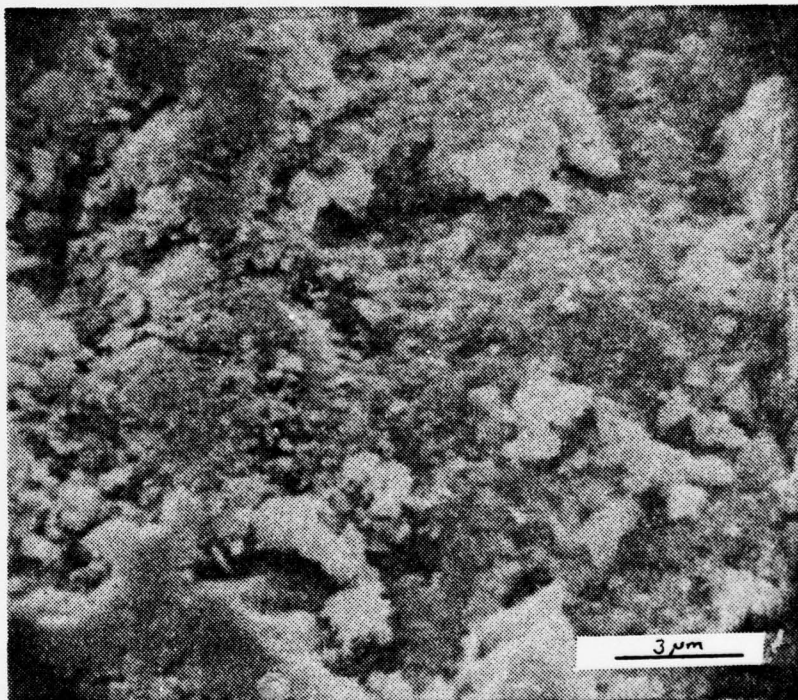

Figure 53. Corrosion layer surface; note the lack of the spiny needle-like crystals reported in battery life. Lead-antimony battery PbSb#1, 35 cycles, 6000X.

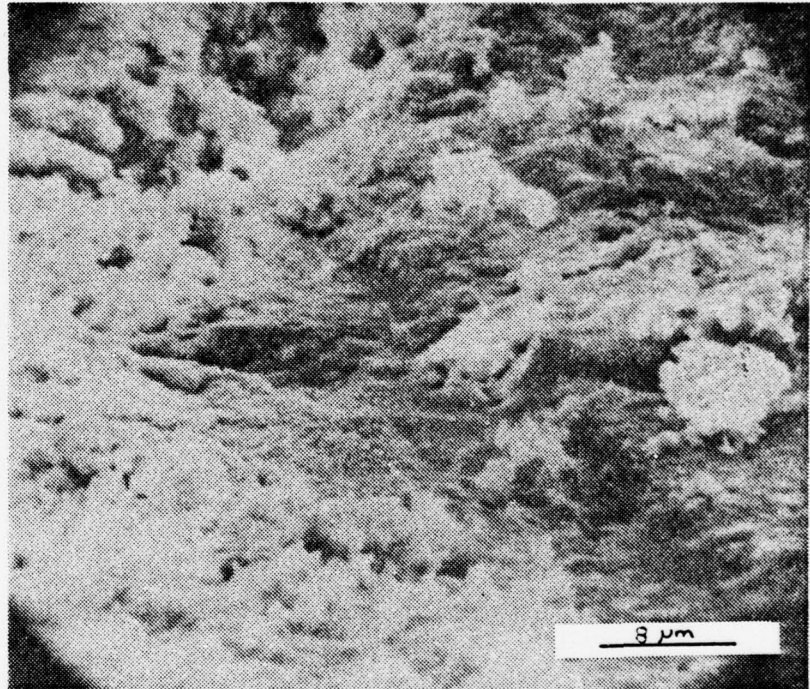

Figure 54. Corrosion layer surface; note the lack of the spiny needle-like crystals reported earlier. Lead-antimony battery PbSb#1, 35 cycles, 2400X.

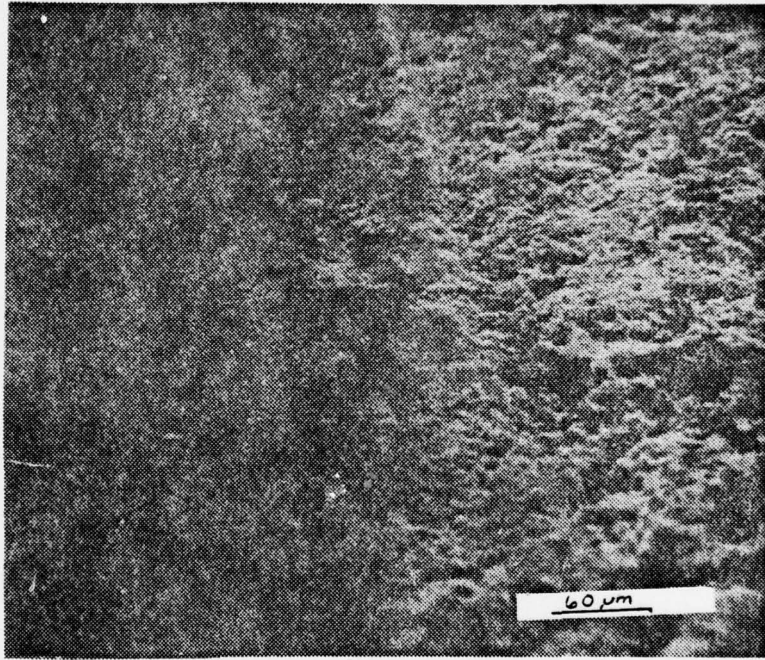

Figure 55. Grid-active material interface in which the corrosion layer measures an average 60 μm . Lead-antimony battery, 35 cycles, PbSb#1, 240X.

at the surface of the grid the structure had increased in size (indicating its development was continuing (Figs. 56, 57)). Large coralloid structure had formed on the underside of the dome-like shapes of the active material (Fig. 58). The coralloid structure has the appearance of a structurally weak network, which would encourage shedding of the active material. The nodular structure of this coralloid appears to be conducive to loss of structural integrity at the nodes, allowing the nodules to fall away, and causing loss of electrical contact with the remaining structure. Measurements of the sediments found in the bottom of extensively cycled cells [31] seems to be of the same general size as these nodules.

Another possible correlation of coralloid structure formation with capacity loss is that the formation of lead-sulfate crystals upon discharge can more easily passivate underlying lead dioxide by encasing it within the core of the coralloid structure [32].

PbSb#2 experienced a similar formation of coralloid as cycling progressed, but because its development proceeded over a somewhat longer period of time, some additional insight into the steps of its formation was gained. The active material near the center of the pellet started its transition to the void filled network of the coralloid structure, with voids on the order of 12-20 μm and not clearly defined (Figs. 59, 60). Near the grid no similar transformation was evident; in fact the active material had changed

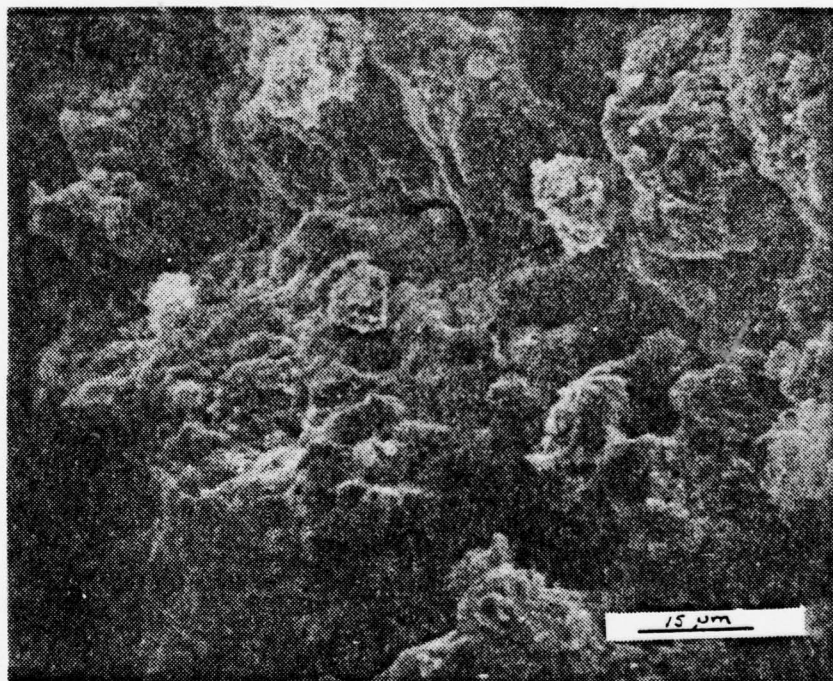

Figure 56. Surface of the enlarged coralloid structure at the grid surface with repeated cycling. Lead-antimony battery PbSb#1, 45 cycles, 1100X.

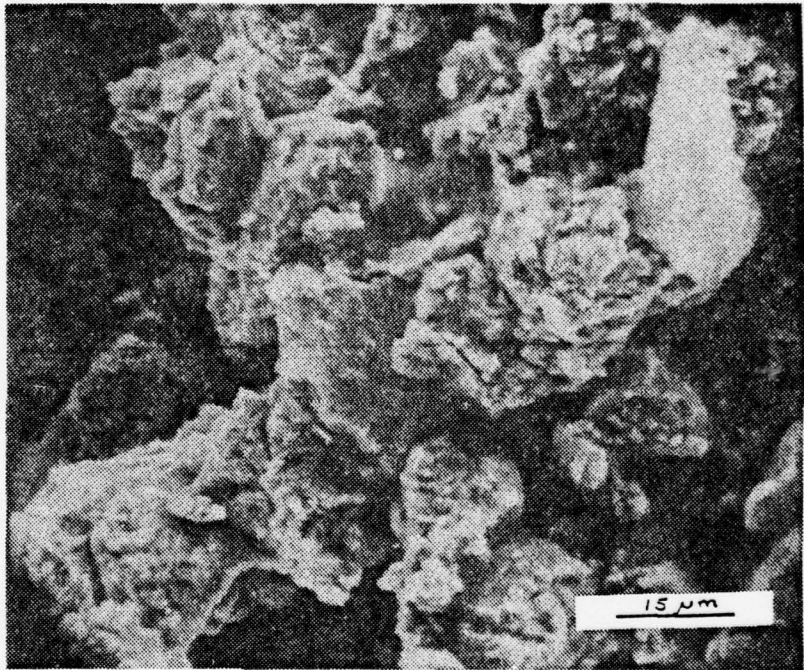

Figure 57. Enlarged coralloid near the grid. Lead-antimony battery PbSb#1, 45 cycles, 1100X.

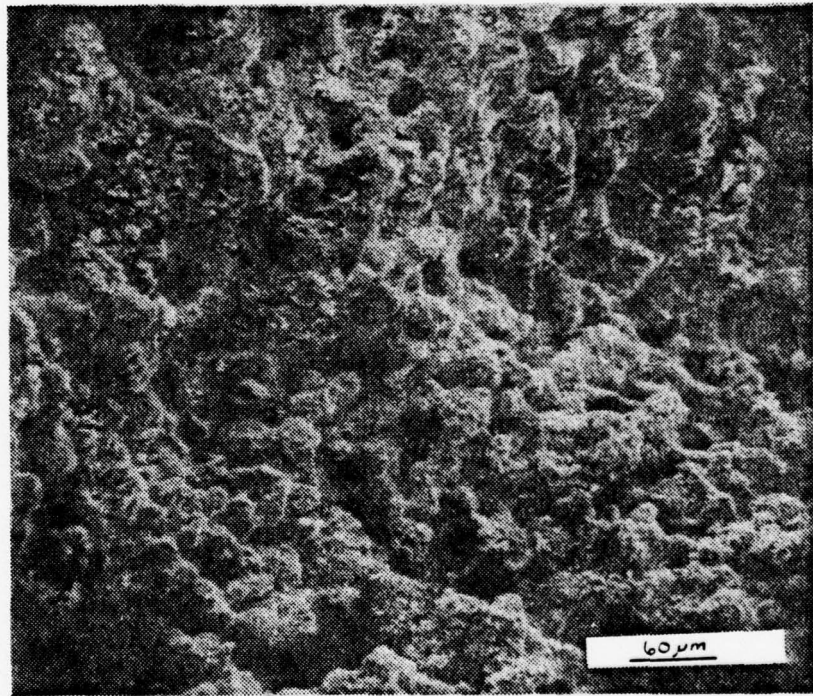

Figure 58. Active material coralloid structure on the undersurface of the dome-like structure. Lead-antimony battery PbSb#1, 45 cycles, 210X.

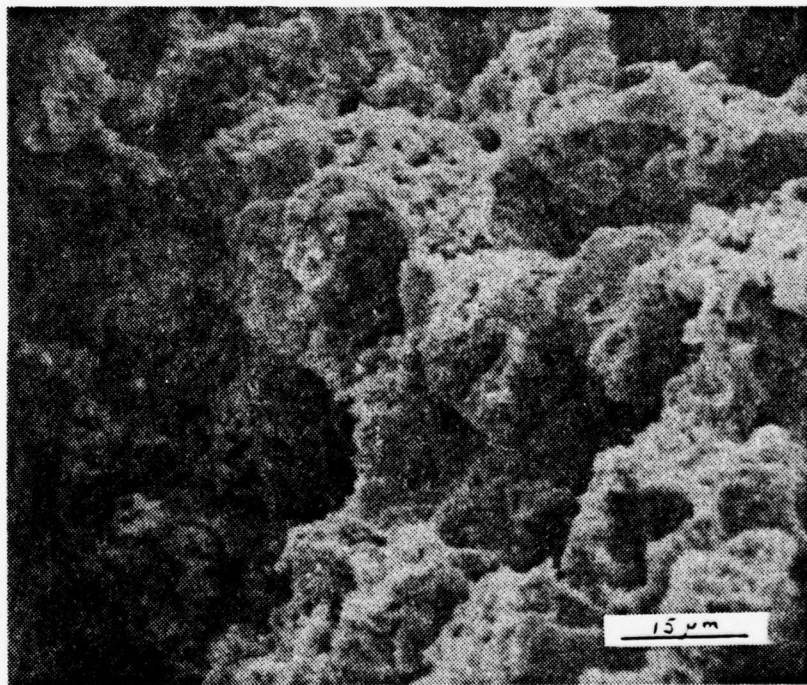

Figure 59. Beginning formation of the coralloid structure by the forming of voids at the center of the active material. Lead-antimony battery PbSb#2, 40 cycles, 1200X.

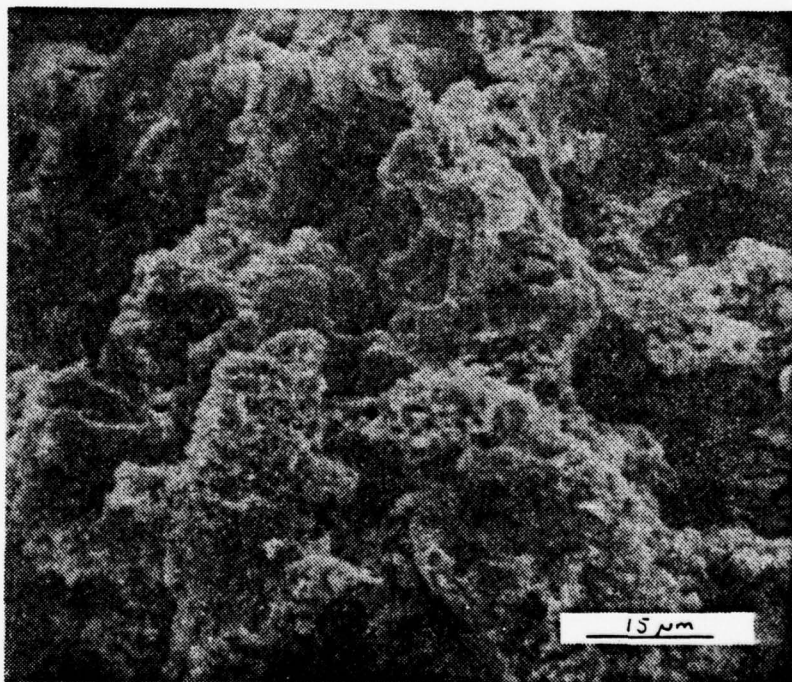

Figure 60. The voids forming as the first stage of formation of the coralloid network. Lead-antimony battery PbSb#2, 40 cycles, 1200X.

little over the course of the first 40 cycles (Fig. 61). The active material near the grid underwent some enlargement of the agglomerates of PbO_2 which make up this active material (Fig. 62).

When the battery reached 50 cycles the corrosion layer seemed to have decreased in thickness (Fig. 63), leading to the belief that the transformation of this corrosion product into usable active material has been accelerated. Observed with this decrease was the disappearance of the spiny needle-like crystals noted earlier (Fig. 64). These facts seem to indicate that the acceleration of the growth of the coralloid is somehow related to these crystals and that these crystals are related to the performance of the battery. The coralloid structures formation is now in the advanced stages and has begun to take on the nodular appearance of the final stage of development (Fig. 65). The surface of this coralloid appeared as a highly porous arrangement of small agglomerates of PbO_2 (Fig. 66).

At the end of cycle testing, with 60 cycles completed, the transformation into the coralloid structure appeared to be complete and the battery had already experienced a significant loss in capacity. Part of this capacity loss must be attributed to the massive grid failure which this plate suffered. The coralloid formed near the grid, on the side of the failure connected to the terminal, is seen as a small intricate pattern of coralloid believed to be in its first stages of formation (Fig. 67). The larger, older formation of

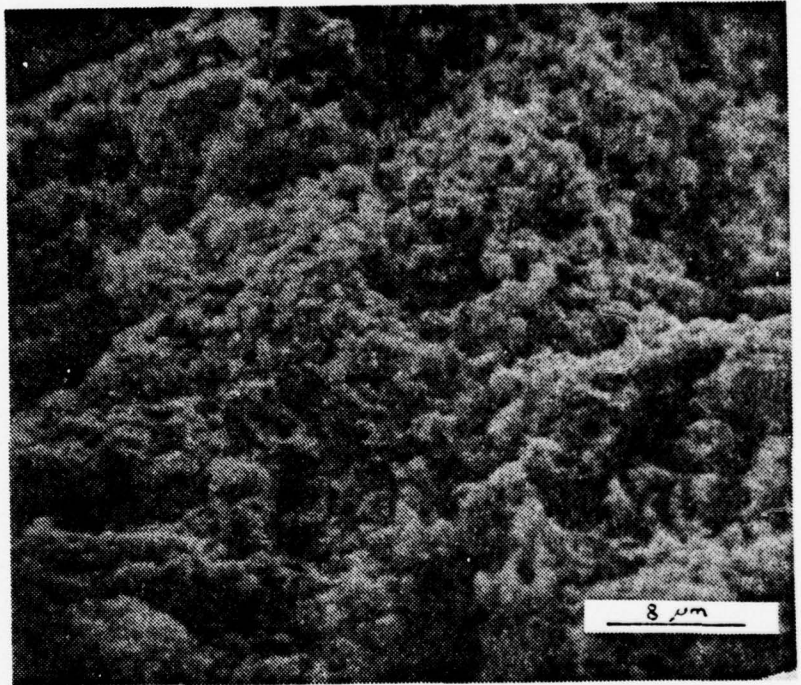

Figure 61. Active material near the grid shows little change from that at earlier stages of cycling. Lead-antimony PbSb#2, 40 cycles, 2400X.

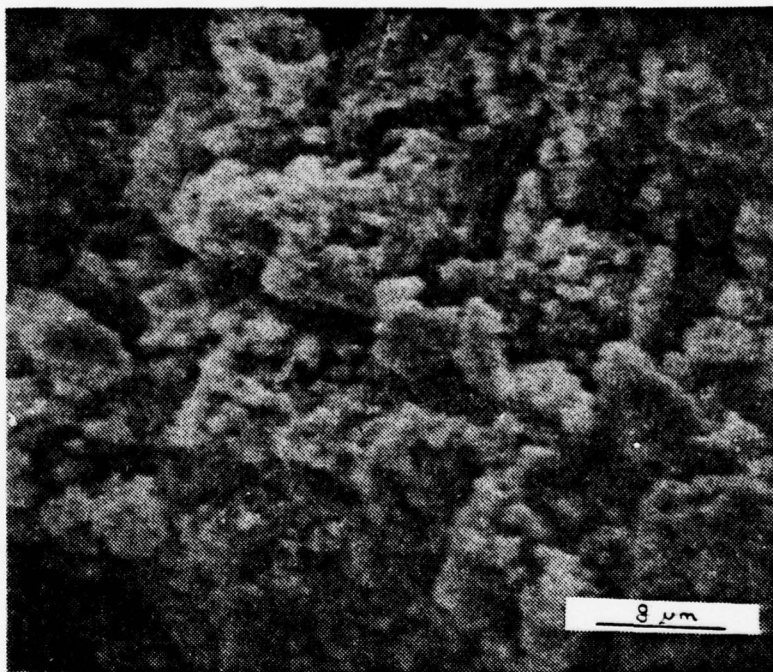

Figure 62. Active material near the grid; note the appearance of the large agglomerates of PbO_2 . Lead-antimony PbSb#2, 40 cycles, 2350X.

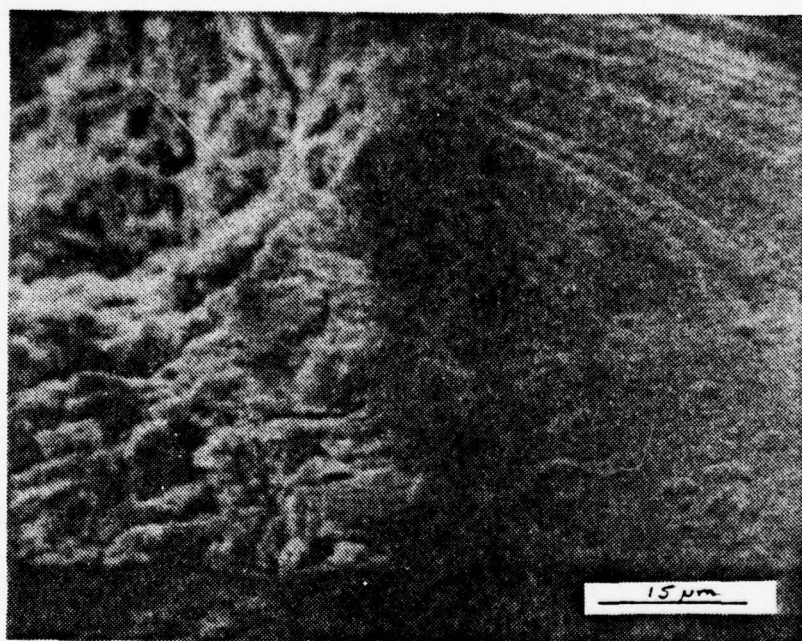

Figure 63. Interface of grid-corrosion layer - active material. The corrosion layer measures about 27 μm thick. Note lack of liquid-like entrapment of active material interface. Lead-antimony battery PbSb#2, 50 cycles, 1400X.

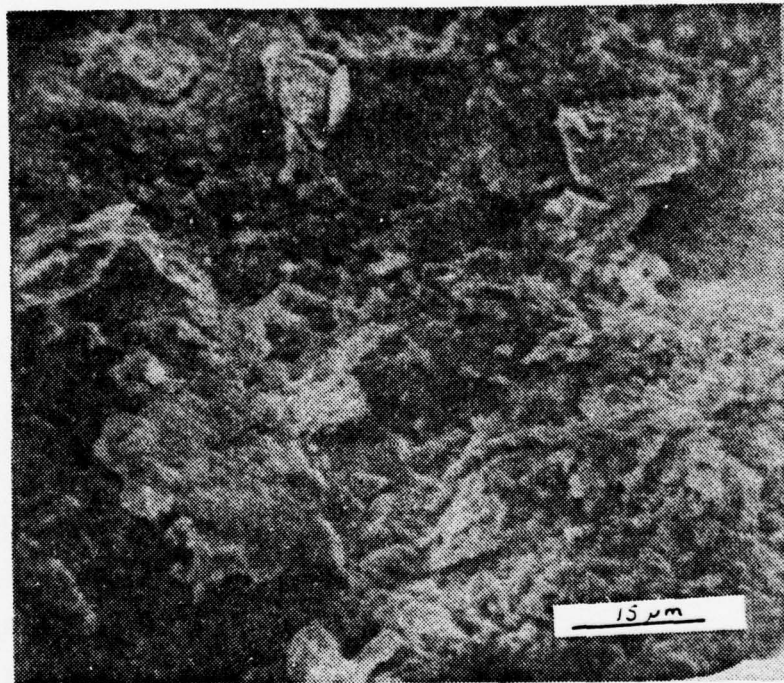

Figure 64. The corrosion layer at the grid; note the lack of the spiny needle-like crystal observed earlier. Lead-antimony, PbSb#2, 50 cycles, 1250X.

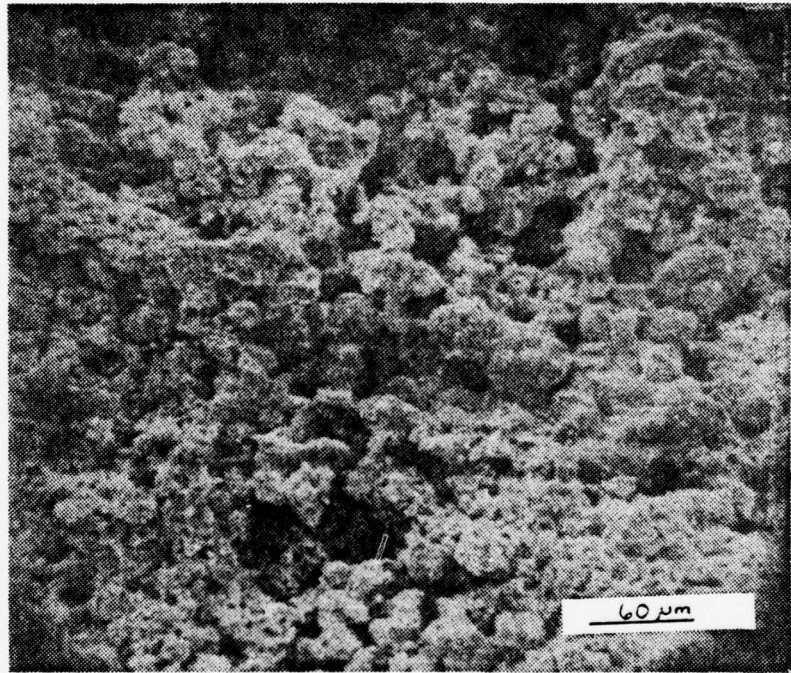

Figure 65. Active material at the center of the pellet in the transition to the coralloid structure. Lead-antimony battery PbSb#2, 50 cycles, 240X.

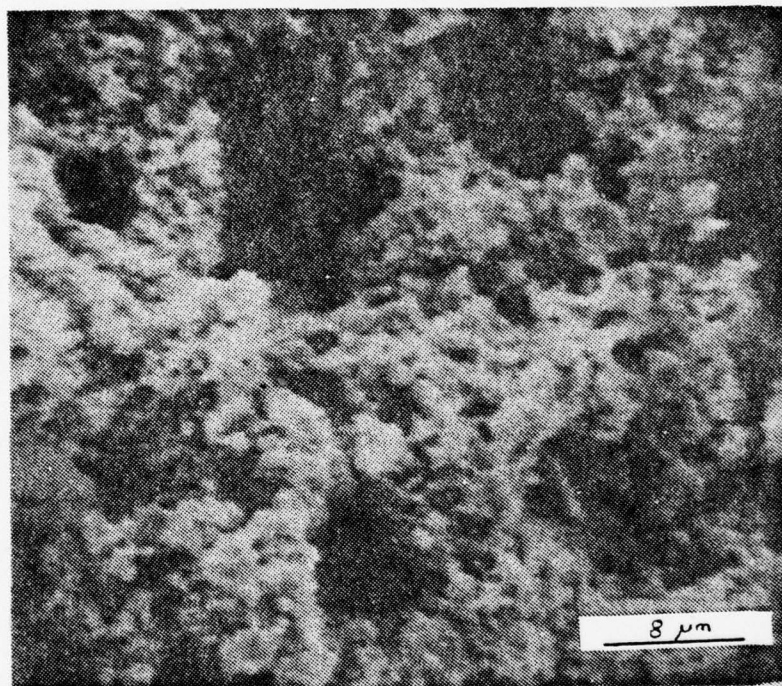

Figure 66. Surface of the coraloid structure.
Lead-antimony PbSb#2, 50 cycles,
2500X.

coralloid structure near the center of the pellet can be seen in Figure 68. This material was taken from a portion of the plate semi-isolated from the battery terminal by grid failure. The small crystals seen partially covering the coralloid network (Fig. 69) are lead-sulfate, which remained unoxidized upon completion of the final charge due to the failure of the grid. This residual lead-sulfate indicates that this section of the plate was not receiving sufficient current to become completely charged.

A summary of results obtained from the tests of the lead-antimony grid alloy batteries is as follows.

1. The end of useful service life is signaled by the formation of the coralloid network. This formation progresses as a normal evolution of the active material as it is continuously cycled.

2. The current paths through the active material could be a contributing factor to the formation of the coralloid structure and the ultimate failure of the battery.

3. The developments observed during these tests are consistent with those observed by Simon [Ref. 32] on the possible mechanisms of formation of the coralloid, i.e., its possible connection with active material isolation by lead-sulfate passivation, and loss of active material by structural breakdown of the coralloid that is formed.

4. The early presence of spiny needle-like crystals was observed, but as cycling progresses and the appearance of the coralloid structure began, these crystals were no longer

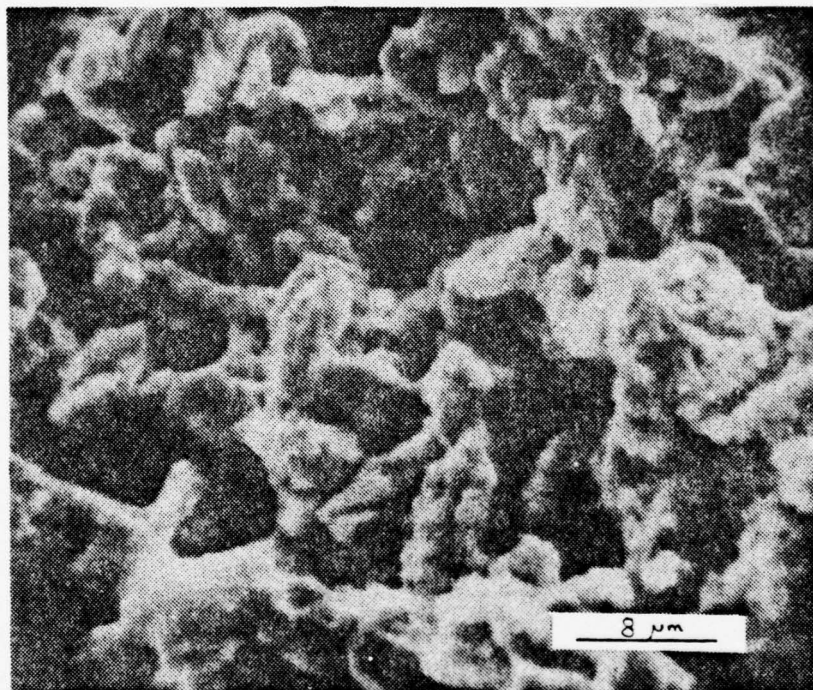

Figure 67. Small coralloid near the grid on a lead-antimony battery PbSb#2, 60 cycles, 2500X.

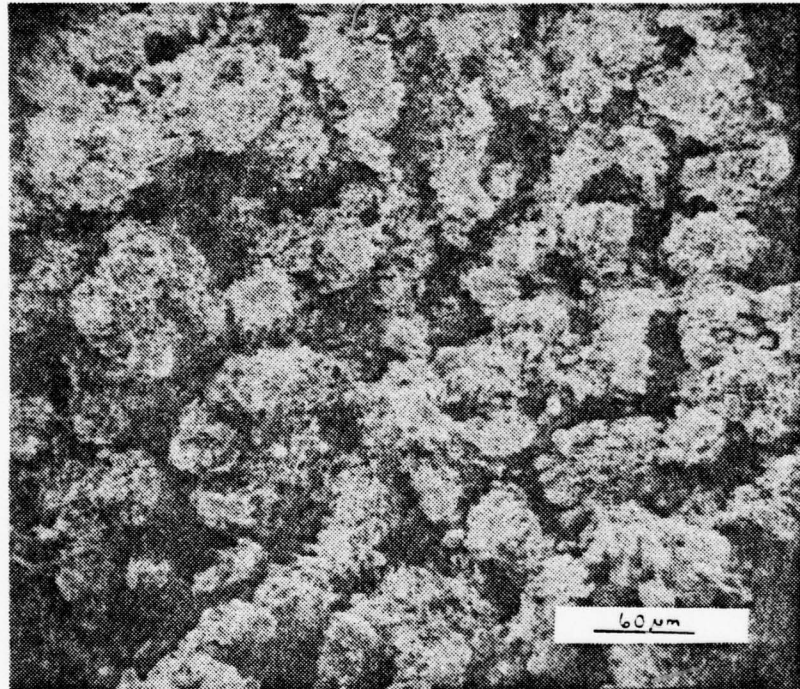

Figure 68. Coralloid structure on the left side of the grid failure with some encapsulation of the coralloid due to lack of current paths to this material causing undercharge lead-antimony battery PbSb#2, 60 cycles, 240X.

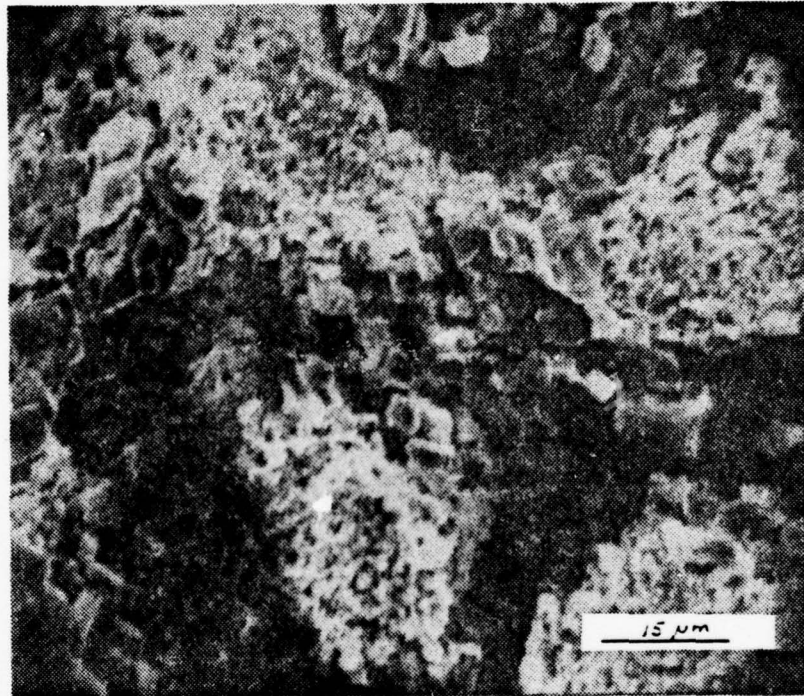

Figure 69. Lead-sulfate partial encapsulation of the coralloid system due to lack of current density reaching this area on charge. Lead-antimony battery PbSb#2, 60 cycles, 1200X.

present. This suggests that these crystals have some effect on the formation of the coralloid and ultimately the service performance of the battery.

2. Changes Observed in the Lead Calcium Type Batteries

The macroscopic appearance of a lead-calcium grid alloy positive plate at zero cycles is shown in Figure 70. The grid bars of this type plate are the same thickness in both directions and approximately twice the size of the lead-antimony grids previously studied, so no failure of the grid was expected, and upon examination of a plate after 60 cycles no evidence of any grid failure could be found. The zero cycle plate was relatively flat, with the active material even with the tops of the grid bars. Upon inspection of the positive plate after a period of 60 cycles the active material had expanded above the tops of the grid bars, showing that some type of volumetric increase of the active material had taken place. Observation of a crater-like surface gave evidence that some shedding had occurred. When the plates were removed from service and the cell disassembled, the active material which had become dissociated from the positive plate was found thoroughly imbedded within the glass fibers of the retainer. Indications of this type of shedding was also observed on the 50 cycle plate, but were not as readily apparent on the plates with fewer cycles.

During the preparation of the zero cycle samples for SEM examination, by the separation method described earlier, it was noted that little bonding existed between the active

material and the grid near the center of the grid bars. The attachment occurred almost exclusively at the near-surface points of the grid (Fig. 72). When the grid was separated from the active material its surface seemed clear of active material at the center and it exhibited the characteristic surface usually associated with removal of the grid from the mold upon casting (Figs. 73, 74). Apparently no corrosion of the grid had taken place during the formation process. The light spots which appear in an irregular arrangement on this surface are thought to be active material randomly bonded in individual agglomerates. It has been shown that in some instances an extremely small corrosion layer may exist after formation [Ref. 30]. In this instance no corrosion layer existed. Both SEM observations (Fig. 75) and optical microscopic observations showed this to be true (Fig. 76). The active material at zero cycles had a uniform, closely packed, highly porous structure (Fig. 77), providing a continuous medium for the conduction of current through this material. Upon closer examination of this material, it appeared to be made of agglomerates of PbO_2 of various sizes, that were spheroidal in shape, closely packed in a tight formation favorable to electrolyte penetration and current conduction (Fig. 78).

A radical change in the morphology of the interface layer at the center of the grid bar had taken place during the first 10 cycles of test. A layer of tightly packed lead-sulfate crystals was formed over the surface of the grid in

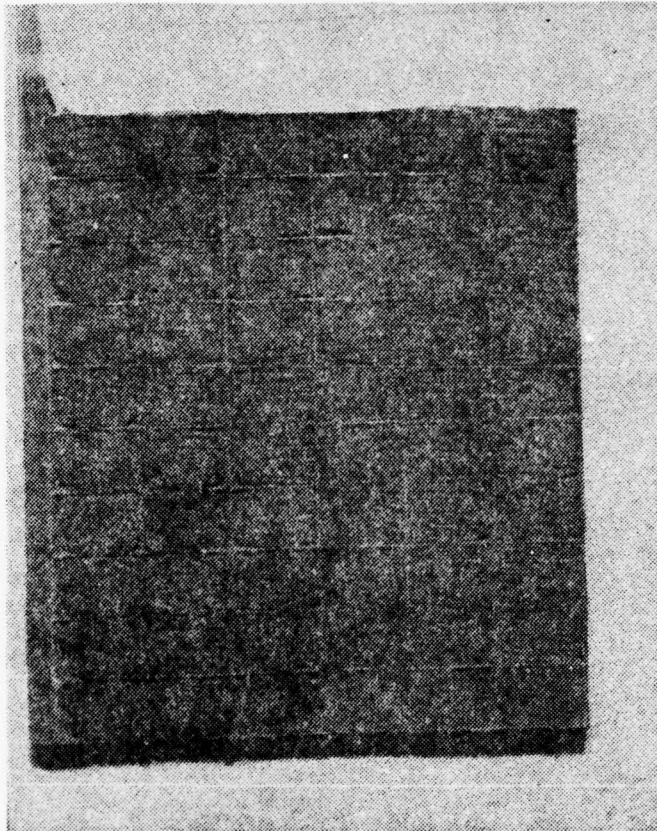

Figure 70. Uncycled positive plate of a lead-calcium grid alloy battery used in the test batteries.

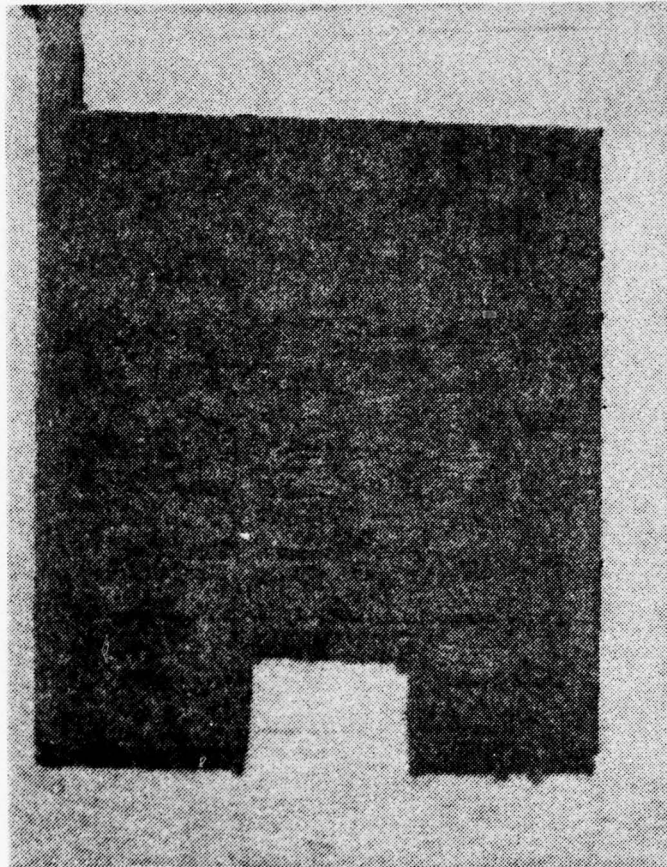

Figure 71. Lead-calcium grid alloy positive plate after 60 cycles of test.

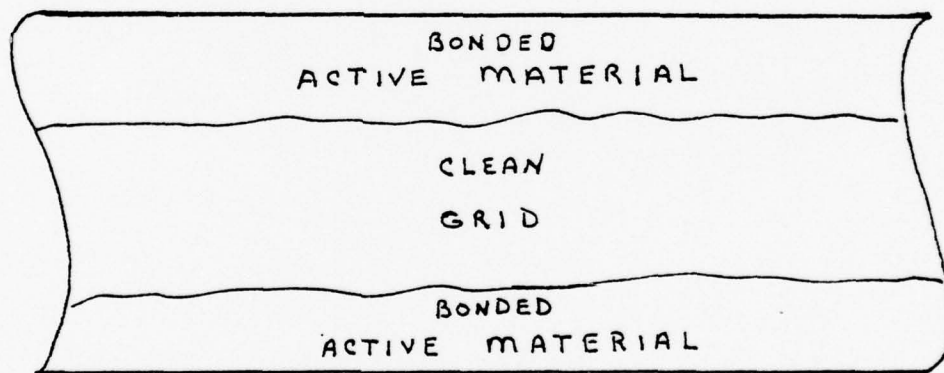
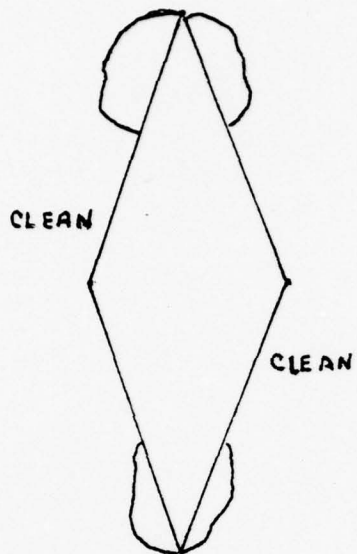

FIGURE 72

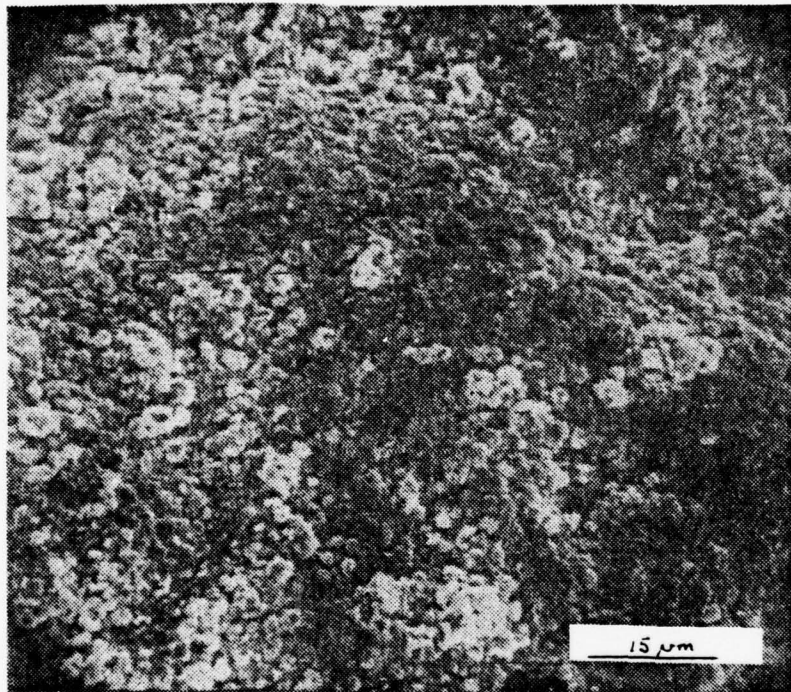

Figure 73. The clear grid surface observed by the separation of the active material from the grid. Lead-calcium PbCA#1, 0 cycles, 1200X.

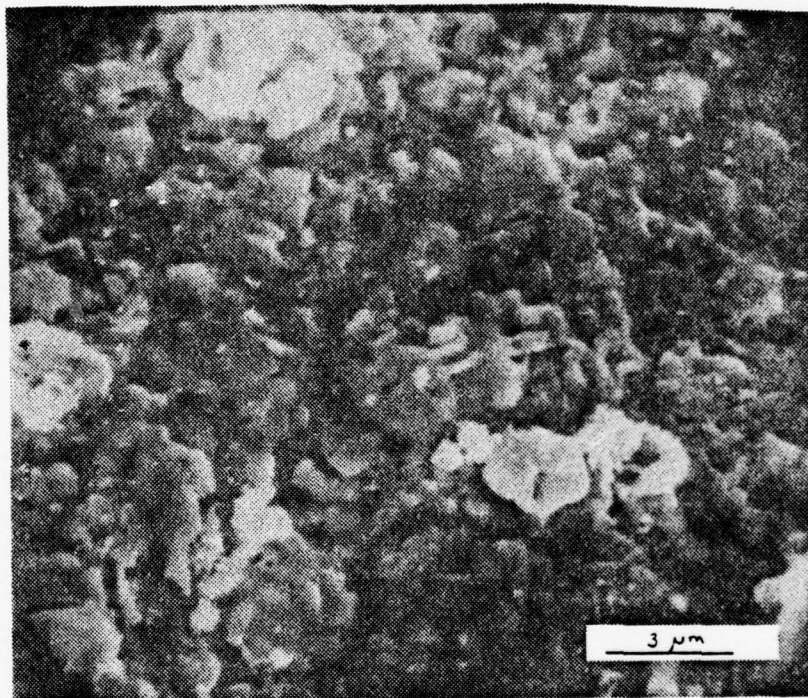

Figure 74. The clear grid surface observed by the separation of the active material from the grid. Lead-calcium PbCA#1, 0 cycles, 6000X.

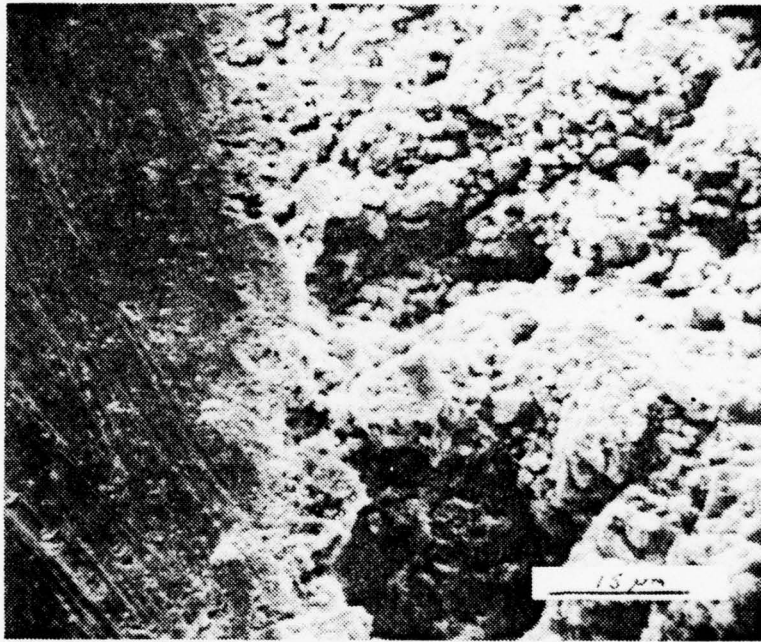

Figure 75. No corrosion layer present between the boundary of the active material and the grid. Lead-calcium, 0 cycles, 1300X.

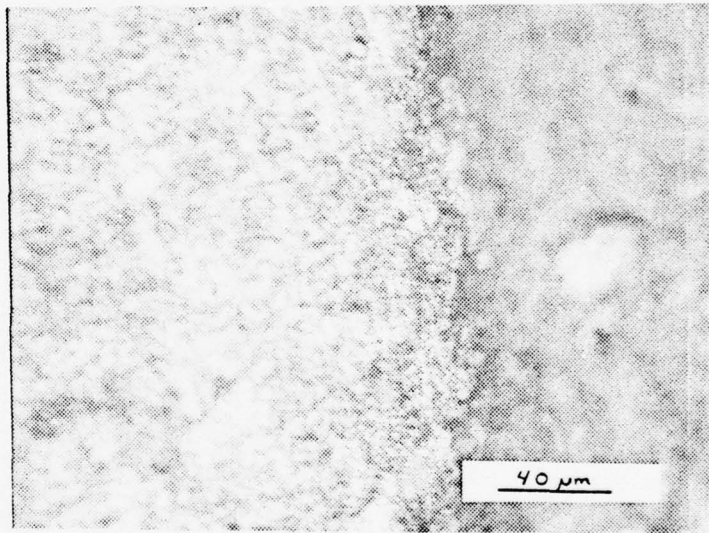

Figure 76. Optical microscope photo confirming that no corrosion layer was present at the boundary between the active material and the grid. Lead-calcium, 0 cycles.

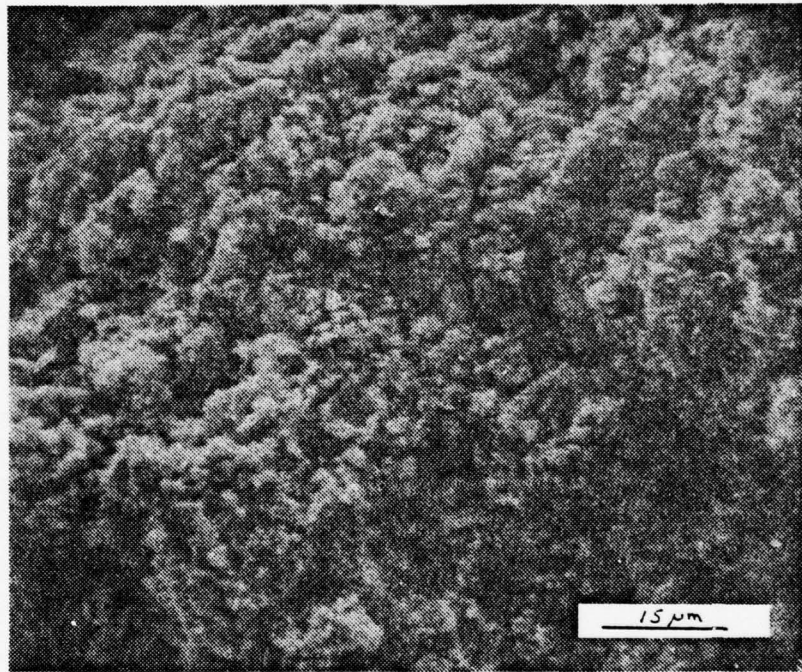

Figure 77. Active material of the zero cycle lead-calcium type positive plate as a uniform closely packed structure. Lead-calcium 0 cycles, 1200X.

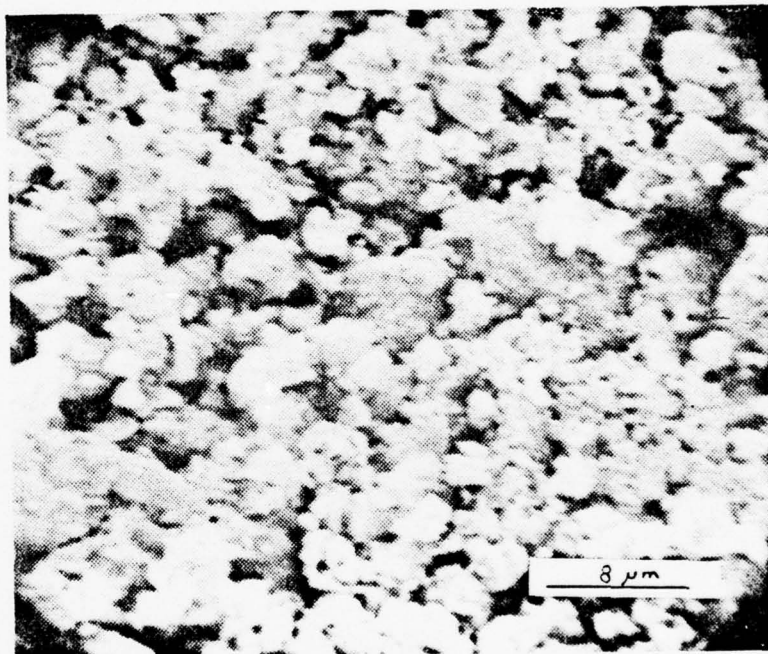

Figure 78. Active material of the lead-calcium plate showing its makeup as a closely packed grouping of spheroidal agglomerate of PbO_2 . Lead-calcium, 0 cycles, 2400X.

the area where previously the bare as cast grid existed (Fig. 79). Upon further examination of this lead-sulfate layer, and on examination of samples of the active material, the lead-sulfate layer was found to exist throughout the active material. The lead-sulfate crystals observed at the grid surface were not in the fully formed state, but rather, partially transformed by charging (Fig. 81). This could be interpreted as meaning that the plate did not receive complete charge to fully transform the lead-sulfate created during discharge; however this would be inconsistent with the battery parameters at the completion of charge, which are considered to prove that complete charge had occurred in accordance with the previously stated procedures. Therefore an alternate explanation was sought.

Tudor, Weisstuch, and Davang [17] reported that, on a shallow discharge routine, thick plate lead-calcium plates maintained their capacity by allowing a reserve of active material to be maintained in the interior of the plates. This was attributed to the fact that penetration during shallow discharge is not complete and much of the positive active material at the center of the plate is not utilized. As the active material sheds from the exterior of the plate, deeper penetration into the plate occurs, utilizing more and more of this reserved active material until the thin plate conditions were reached by the shedding of the active material from the surface of the plates. A similar hypothesis is put forth as a possible explanation of the existence of the sulfate

layer and of the fact that this lead-calcium grid battery showed credible service life on cycle service. The thick plate cells operated on a deep cycle routine form an area of lead-sulfate at the center of the plate which is not converted to PbO_2 on subsequent charges, until the thickness of the plate is effectively reduced by shedding or formation of the coralloid structure. Figure 80 gives a representation of this action as it was observed during the cycling of PbCa#1. The facts that the lead-calcium battery gave the same service life performance comparable to a similar size lead-antimony battery on a deep cycle test routine, and that as the number of cycles increased the lead-sulfate layer was observed to decrease in thickness, lend supportive evidence that this type of reserve mechanism is taking place within the active material of the plate.

The layer of lead-sulfate near the grid (Fig. 81) exhibited a much greater degree of transformation than that at the center of the active material (Fig. 82), which appears as a highly compacted mass of sulfate crystals with little evidence of transformation. At the center of the converting lead sulfate crystals found at the grid interface, the surface of the grid, or a corrosion layer on it, can be seen just below. In this region are seen an array of fine needle-like structures discussed by M. Coyle [27] which are believed to enhance the conduction of current. The active material in the outer layers of the plate, shown in Figures 83 and 84, seems to have taken on a more fuzzy-like texture believed to

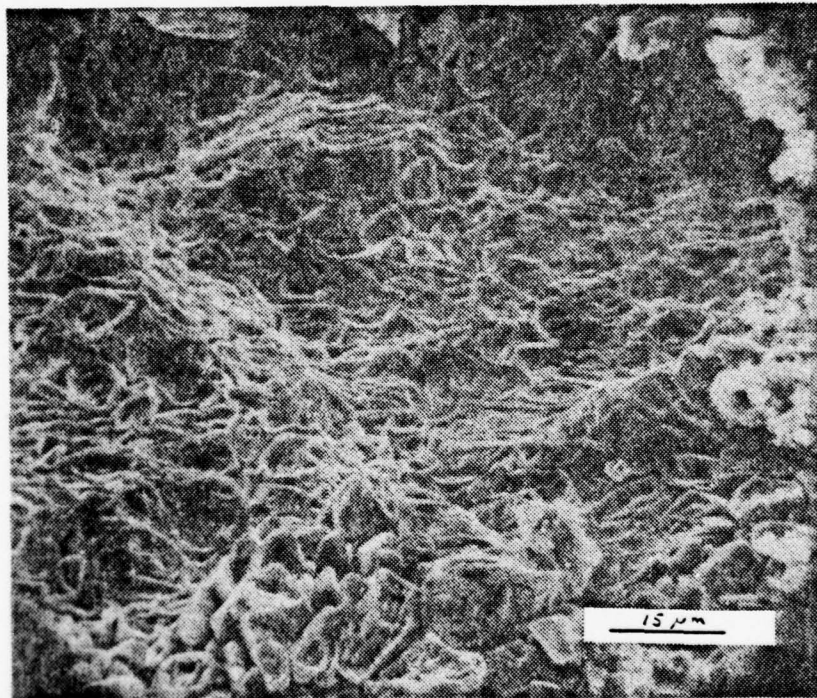
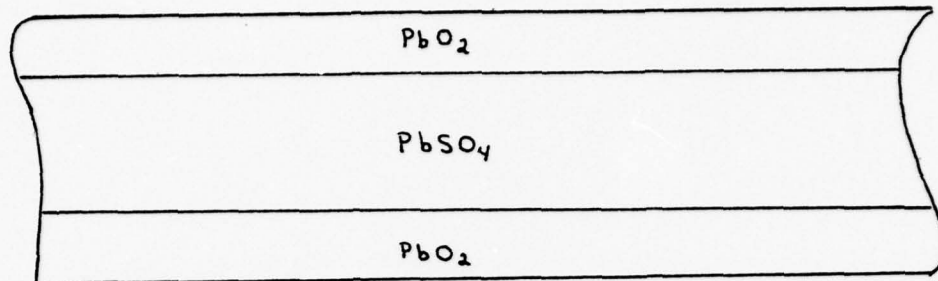
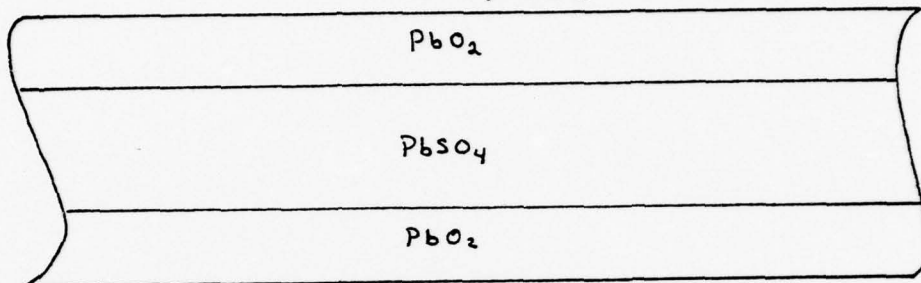

Figure 79. Lead-sulfate layer attached to the grid. Lead-calcium PbCA#1, 10 cycles, 1100X.



CROSS SECTION OF ACTIVE MATERIAL STRUCTURE
10 CYCLES



20 CYCLES

PbSO₄ VERY HARD AND COMPACTED

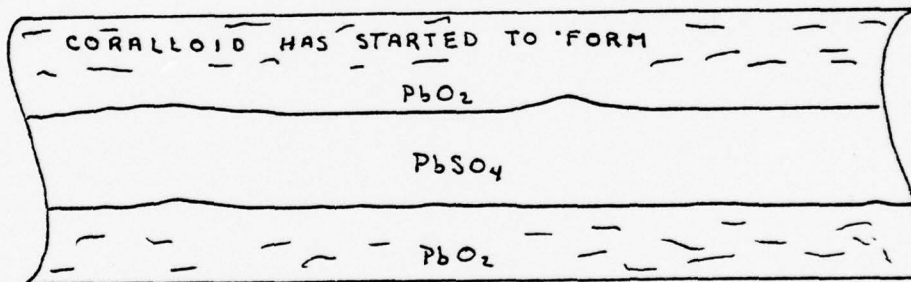

40 CYCLES

PbSO₄ HAS STARTED CONVERSION TO PbO₂

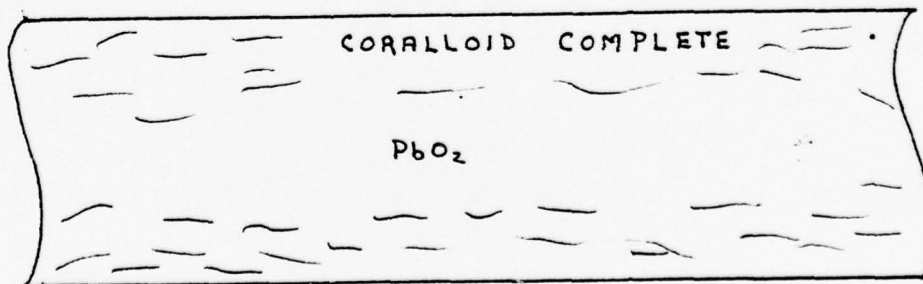

60 CYCLES

NO PbSO₄ LAYER FOUND

FIGURE 80

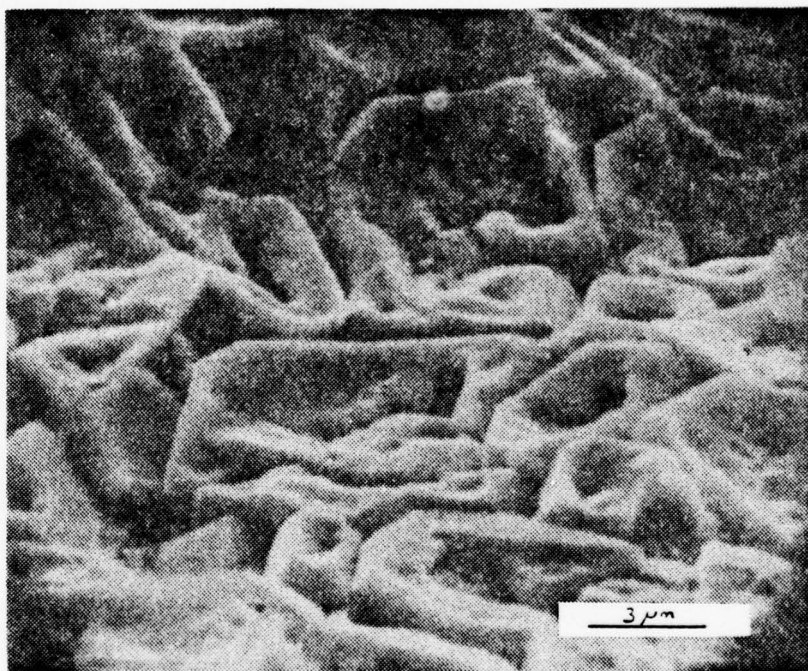

Figure 81. Partially transformed lead-sulfate at the grid surface. The spiny needle-like crystals are in evidence around those crystals. Lead-calcium PbCA#1, 10 cycles, 5500X.

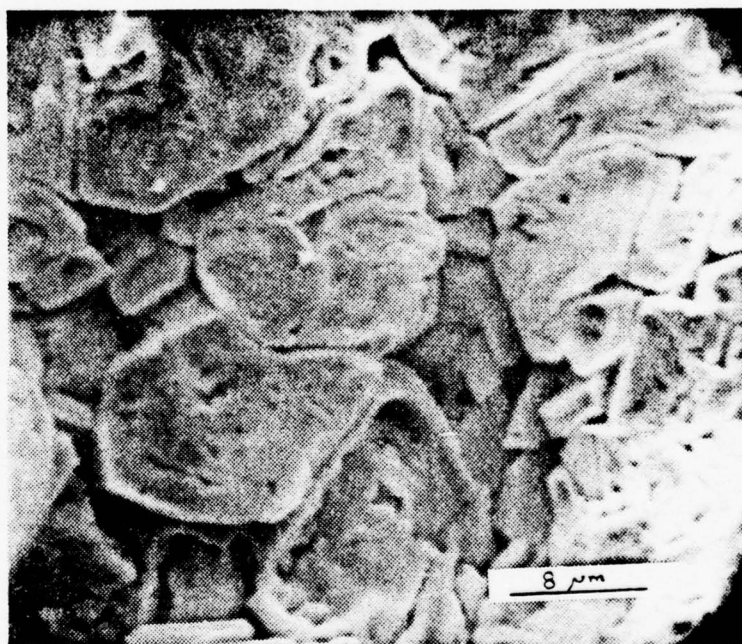

Figure 82. Lead-sulfate at the center of the active material closely packed to form a solid hard center. Lead-calcium PbCA#1, 10 cycles, 2450X.

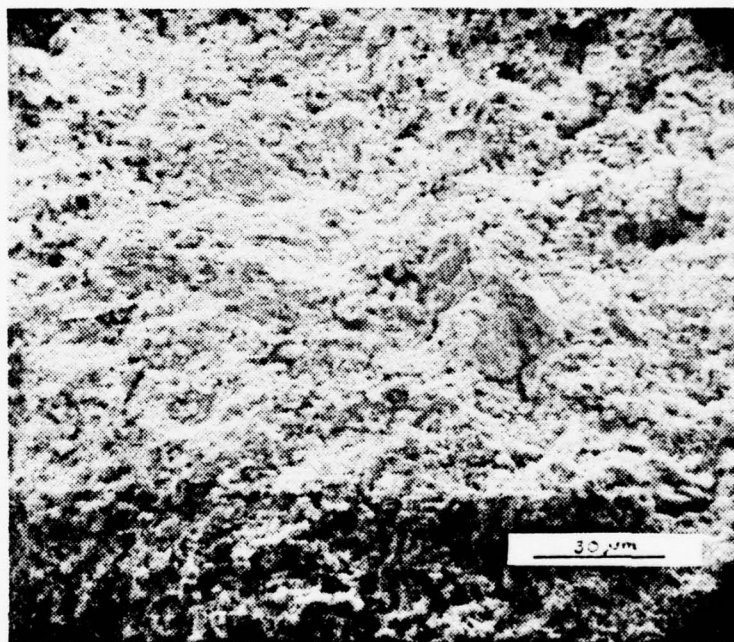

Figure 83. Active material of the outer layers of the positive plate. Lead-calcium, PbCA#1, 10 cycles, 625X.

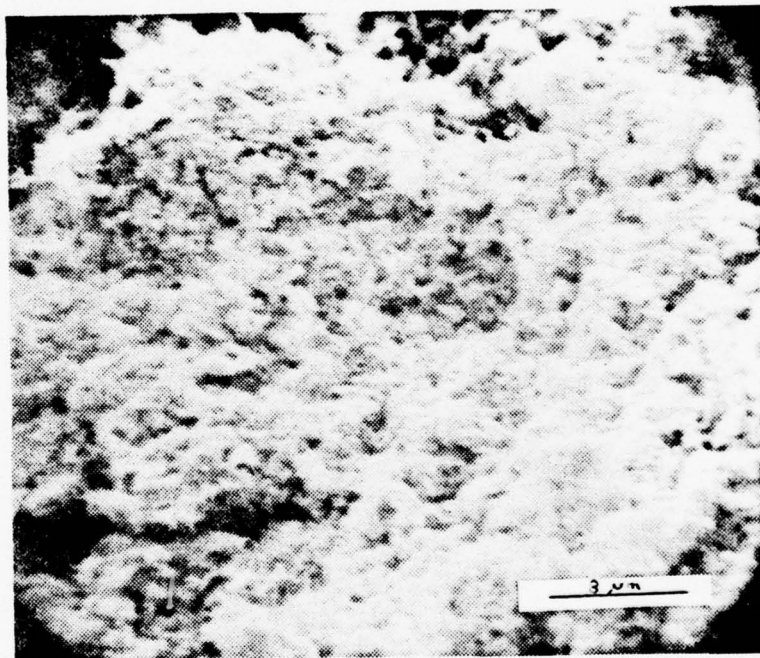

Figure 84. Active material of the outer layers of the positive plate. Lead-calcium PbCA#1, 10 cycles, 2450X.

be the result of its reduction and formation during the cycling process.

After 20 cycles, the lead-sulfate layer still was found to exist throughout a seemingly dense center layer within the positive plate (Figs. 85, 86, 87). When a pellet of this positive plate was broken open, the extent of this layer was visible to the naked eye as a grayish layer between the two rusty dark brown layers of active material. This layer defied all photographic techniques attempted. The active material in the outer layers of the plate also showed little change over that observed at 10 cycles (Figs. 88, 89). Except for a slight enlargement of the agglomerates of the PbO_2 crystals making up the bulk of this material, it remained a uniform porous layer of active material believed to be conducive for good utilization and good performance. At the grid-active material interface the partially converted lead-sulfate crystals (Fig. 90) were now covered by a greater amount of the spiny needle-like crystals, both between the lead-sulfate crystals and over their face.

An important structural transformation took place within the active material during the next period on the test routine. There were two different structural changes, one involving the lead-sulfate layer and the other taking place in the outer layer of the PbO_2 . The lead-sulfate at the center of the active material and that near the grid showed signs of increased conversion to PbO_2 had taken place (Figs. 91, 92). Within the center layer of lead-sulfate, spaces were

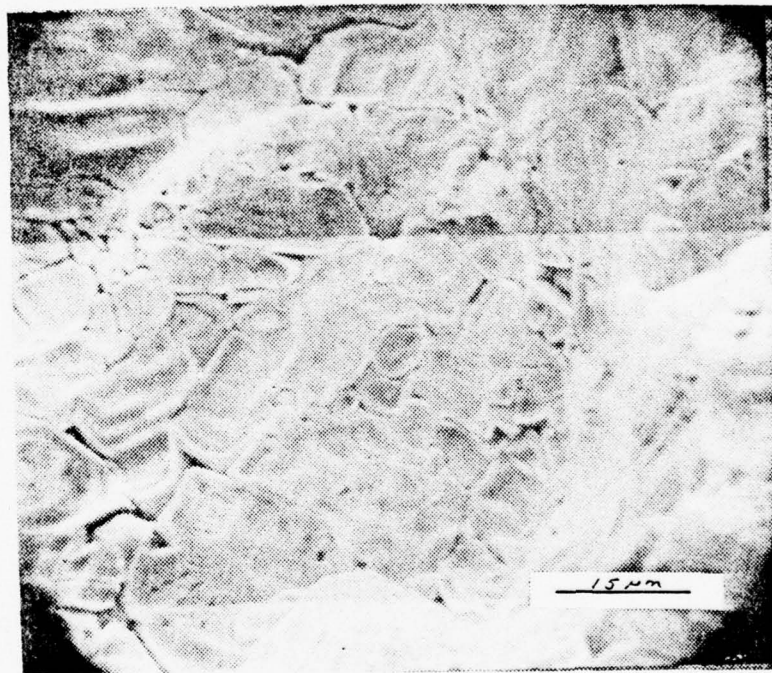

Figure 85. Center layer of compacted lead-sulfate crystals which was found in the thick plate lead-calcium battery. Lead-calcium PbCA#1, 20 cycles, 1300X.



Figure 86. Center layer of lead-sulfate observed. Note the appearance of partially encapsulated PbO_2 . Lead-calcium PbCA#1, 20 cycles, 2750X.

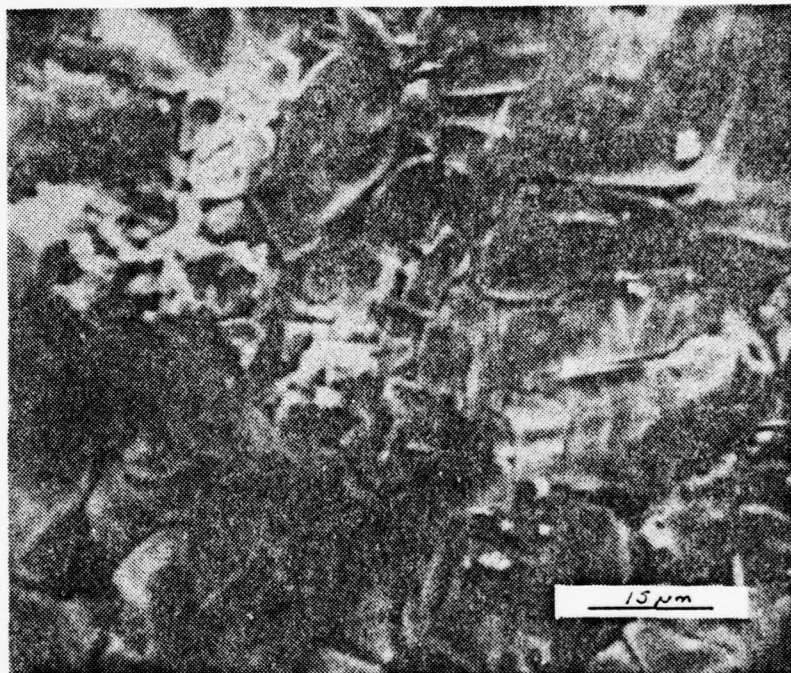

Figure 87. Center layer of lead-sulfate. Lead-calcium PbCA#1, 20 cycles, 1200X.

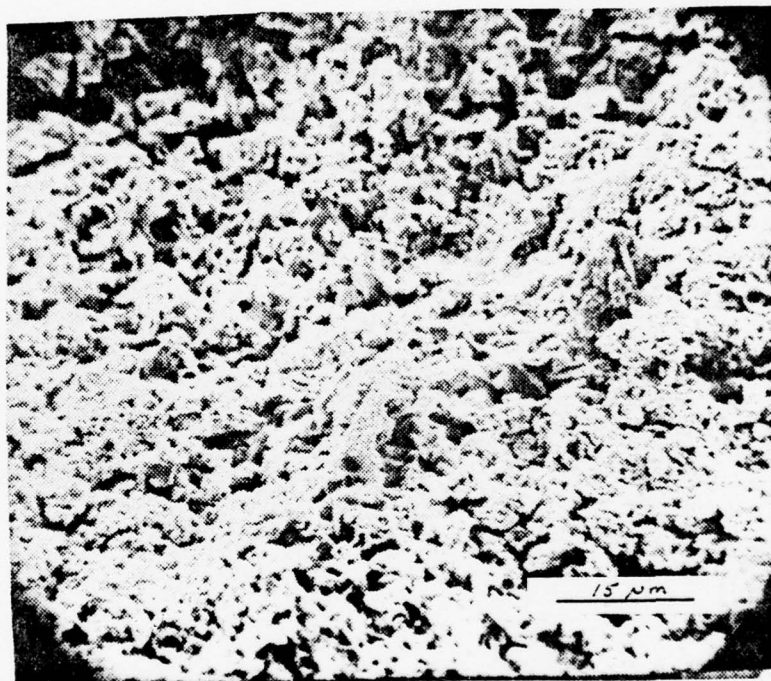

Figure 88. Active material which was bonded to the grid at the top and bottom. Lead-calcium PbCA#1, 20 cycles, 1300X.

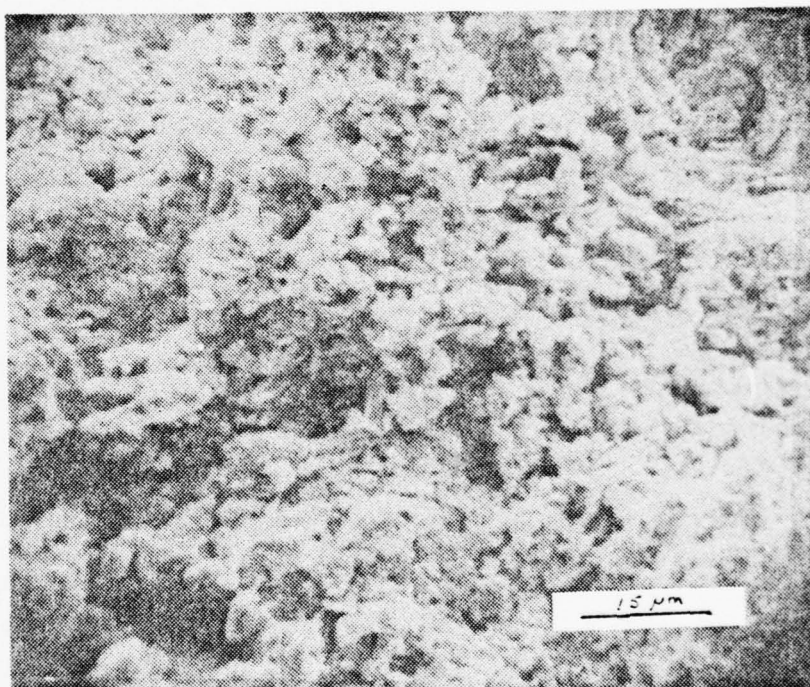

Figure 89. Active material in the outer layers of the plate. Note the enlargement of the agglomerate of PbO_2 . Lead-calcium PbCA#1, 20 cycles, 1200X.

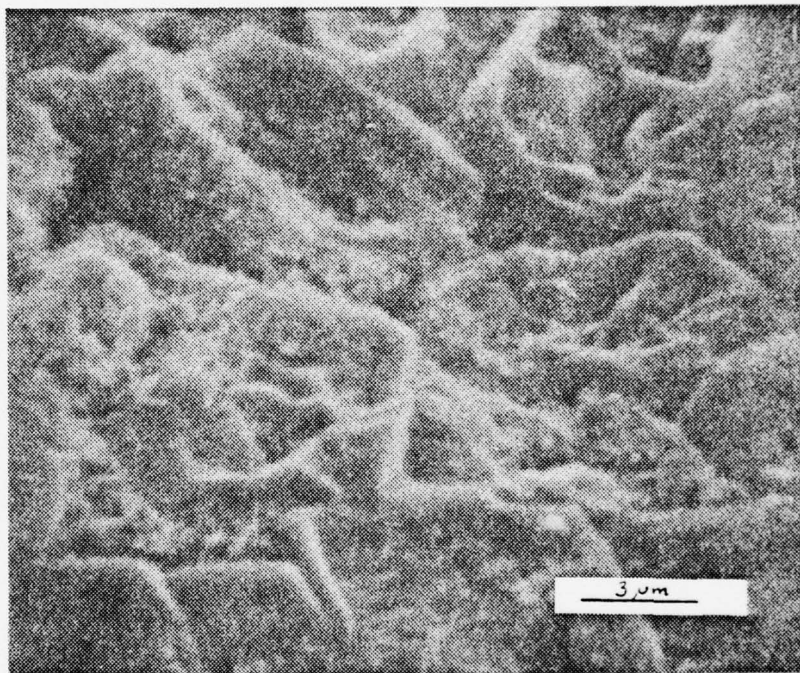

Figure 90. Lead-sulfate crystals at the grid surface covered by the needle-like crystals. Lead-calcium PbCA#1, 20 cycles, 5400X.

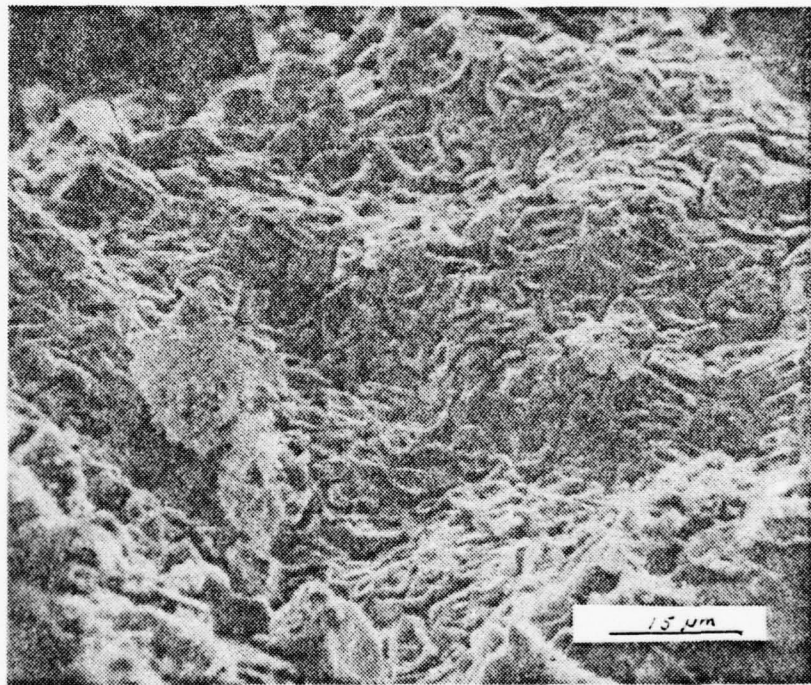

Figure 91. Lead-sulfate covering the grid surface. These appear to have been in a greater state of transformation as evidenced by the spaces that exist between the crystals. Lead-calcium PbCA#1, 40 cycles, 1275X.

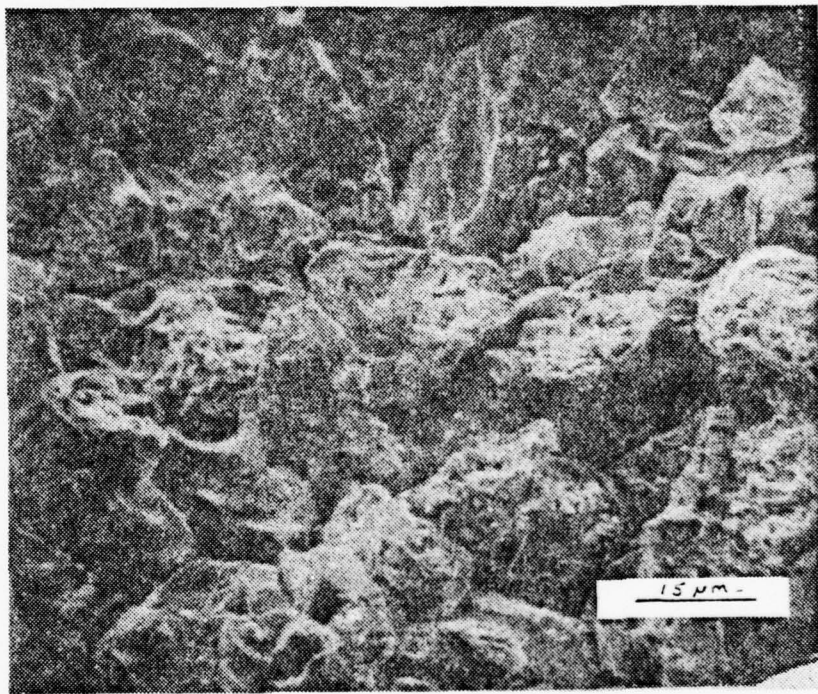

Figure 92. Lead-sulfate layer at the center of the active material. Note the appearance of the spaces between these crystals. Lead-calcium PbCA#1, 40 cycles, 1150X.

observed to have formed between the lead-sulfate crystals. The interface lead-sulfate also could be seen to be transformed to a greater degree, and lost some of its appearance of a continuous smooth layer. Upon examination of the cross section of the active material, an observable decrease in the thickness of the sulfate layer was noted, suggesting that this reserve was now being used. The active material in the outer layer of plate (Fig. 93) had already begun to take on the form of the coralloid structure described previously, and believed to be an indication that the end of service of the active material is near. It appears that the same actions are at work in the active material to cause its formation. The active material bonded to the grid has also begun to take on a more ordered appearance (Fig. 94), showing that the formation of the coralloid structure has already begun in this area.

Further study of the area around the lead-sulfate revealed a new structure not before seen near the base and between the lead sulfate crystals (Fig. 95). This structure proved to be extremely difficult to resolve due to the magnifications necessary. It appeared to be in the early stages of development. No conjecture was made as to the nature or composition of this material or as to its action as it may relate to the processes taking place within the battery, but it is included here for consideration as a possible area of future study. Figure 96 shows this structure as it existed between the crystals of lead-sulfate at 60 cycles. This is

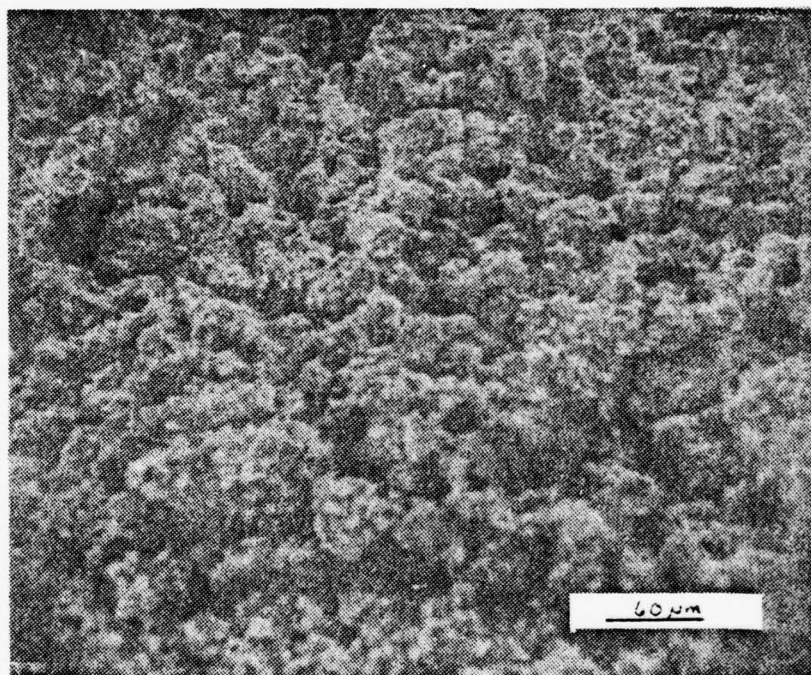

Figure 93. Early development of the coraloid near the surface of the plate in the active material. Lead-calcium PbCA#1, 40 cycles, 240X.

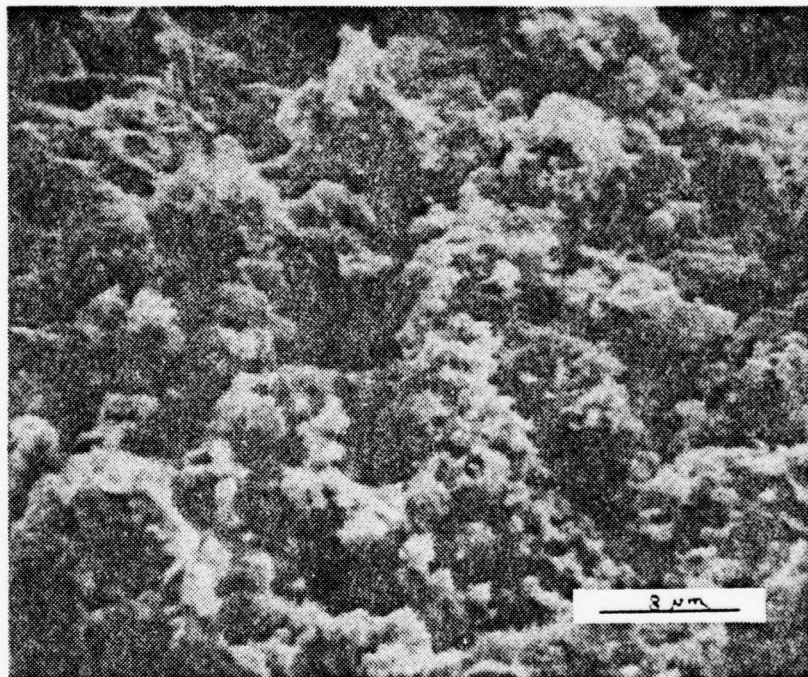

Figure 94. Active material at the interface with the grid. Note the ordered arrangement and development of voids beginning to form in this active material. Lead-calcium PbCA#1, 40 cycles, 2500X.

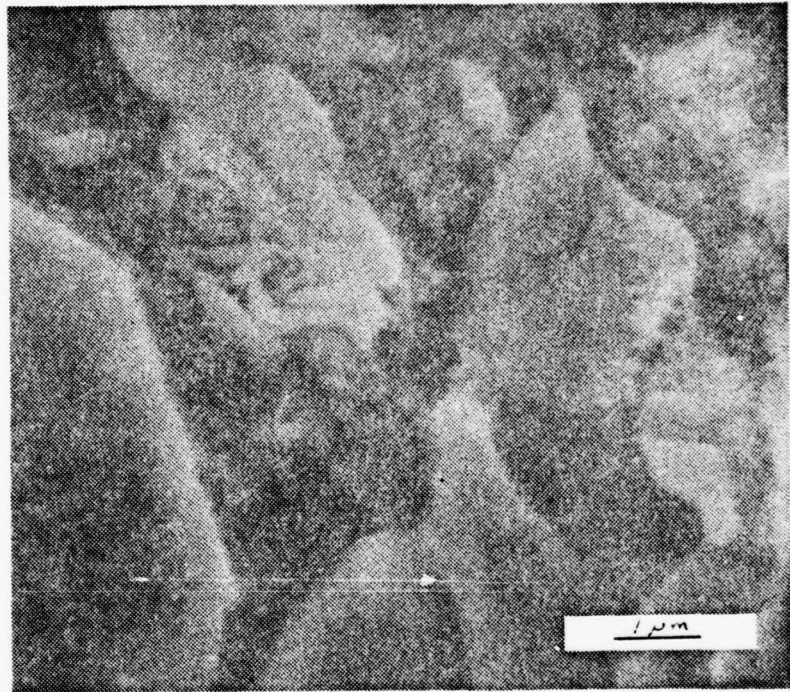

Figure 95. Area between lead-sulfate crystals near the grid. Note the dendritic crystals in these areas. Lead-calcium PbCA#1, 40 cycles, 12700X.

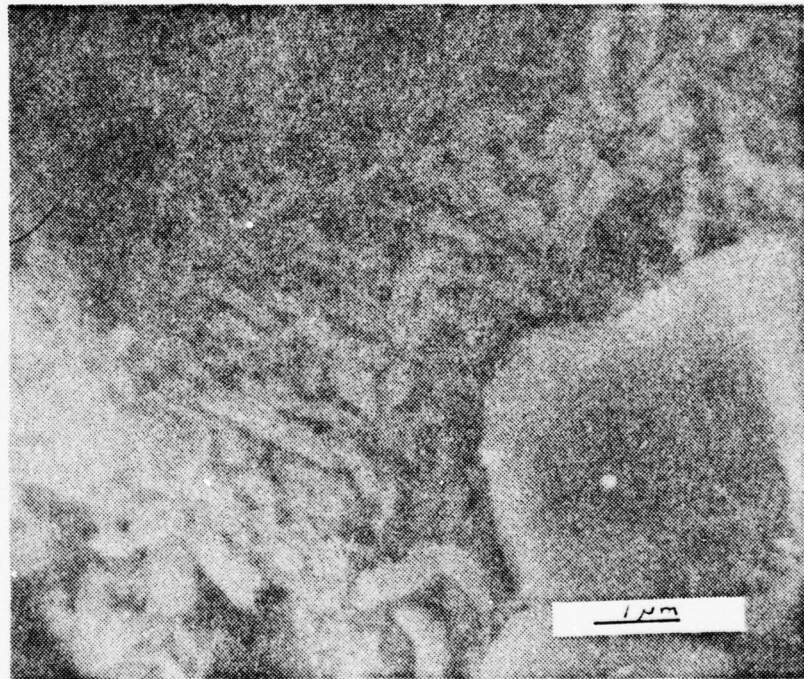

Figure 96. Area between lead-sulfate crystals near the grid. The dentic crystals are seen as increasing in number as cycling proceeds. Lead-calcium PbCA#1, 60 cycles, 12500X.

obviously not the needle-like structure described by M. Coyle [27].

The plate studied at 50 cycles on the test routine showed that completion of the formation of the coralloid structure had taken place in the outer layer of active material (Figs. 97, 98). This coralloid is now believed to be in the form most conducive to shedding of the active material and indicates that failure of the plate has already begun. The coralloid seen was nodular in appearance, with the nodes connected together by a somewhat thinner branch of the structure. The size of these nodes, between 20-25 μm , correlates favorably with the size of the sediments found at the end of life [31]. A significant change has also occurred at the center of the active material (Fig. 99). The lead-sulfate had started its transition into active material, and the lead-sulfate crystals that remained showed signs of nearly complete transformation to PbO_2 . The lead-sulfate at the interface with the grid (Fig. 100) was seen to also have experienced greater conversion to PbO_2 , and now exists on a layer of active material believed to be firmly bonded to the grid.

At 60 cycles the scenario was complete. The coralloid structure (Fig. 101) had formed throughout most of the outer layers of active material, with the large voids created by its formation accounting for the increase in the volume of the plates. The lead-sulfate layer no longer existed at the center of the plate, but had been completely transformed

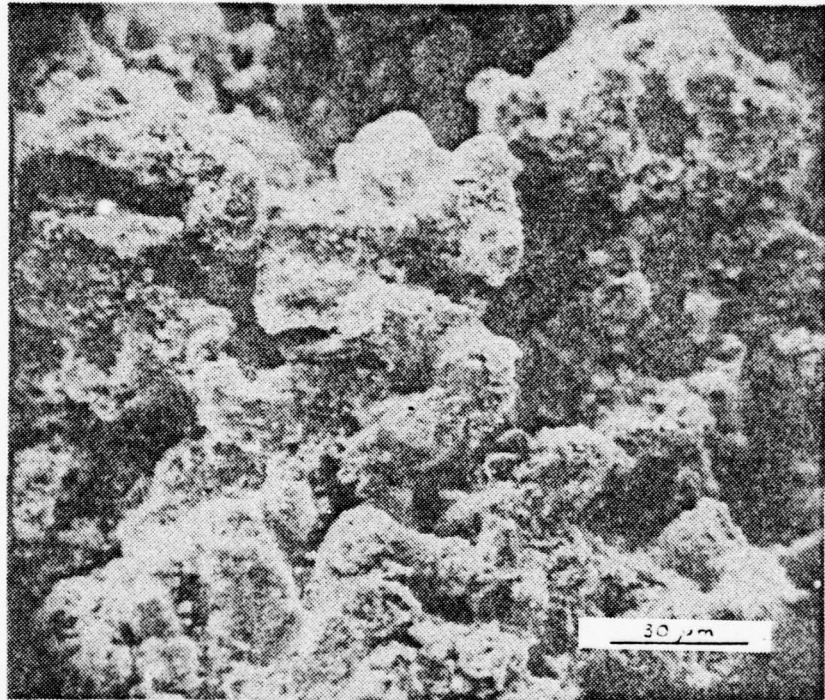

Figure 97. Coralloid structure within the active material near the grid interface. Lead-calcium PbCA#1, 50 cycles, 660X.

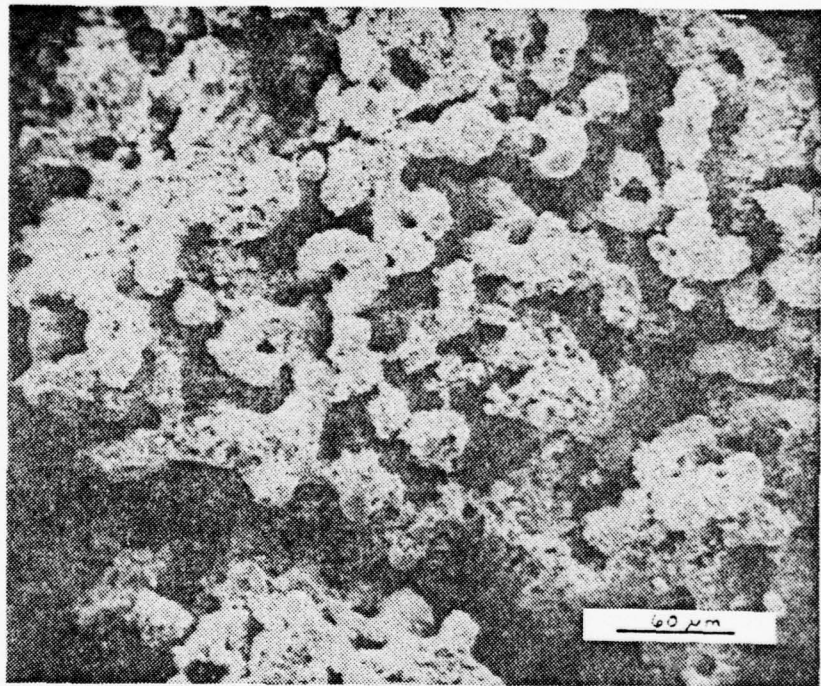

Figure 98. Coralloid structure within the active material near the surface of the photo. Lead-calcium PbCA#1, 50 cycles, 260X.

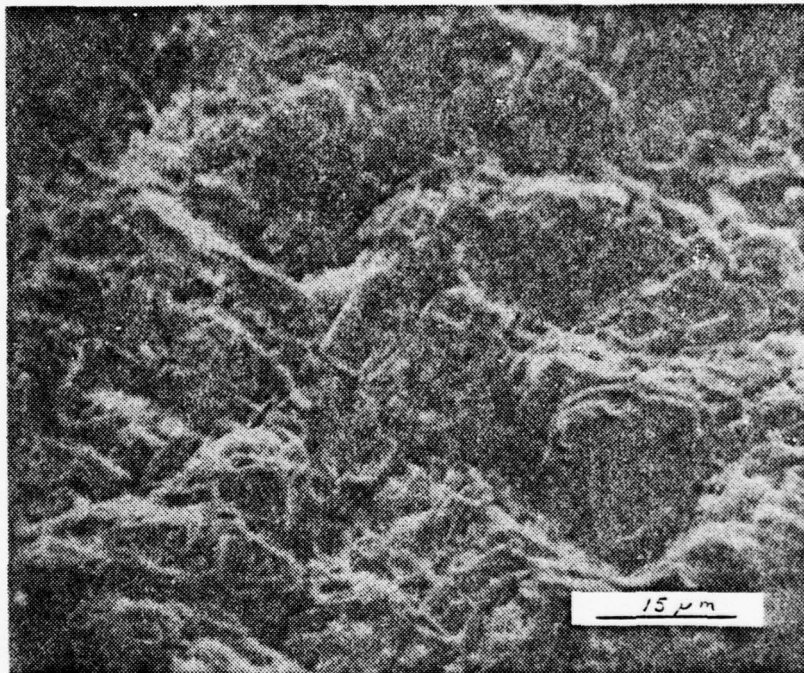

Figure 99. Lead-sulfate at the center of the active material. This layer has now begun its transformation into PbO_2 . Lead-calcium PbCA#1, 50 cycles, 1300X.

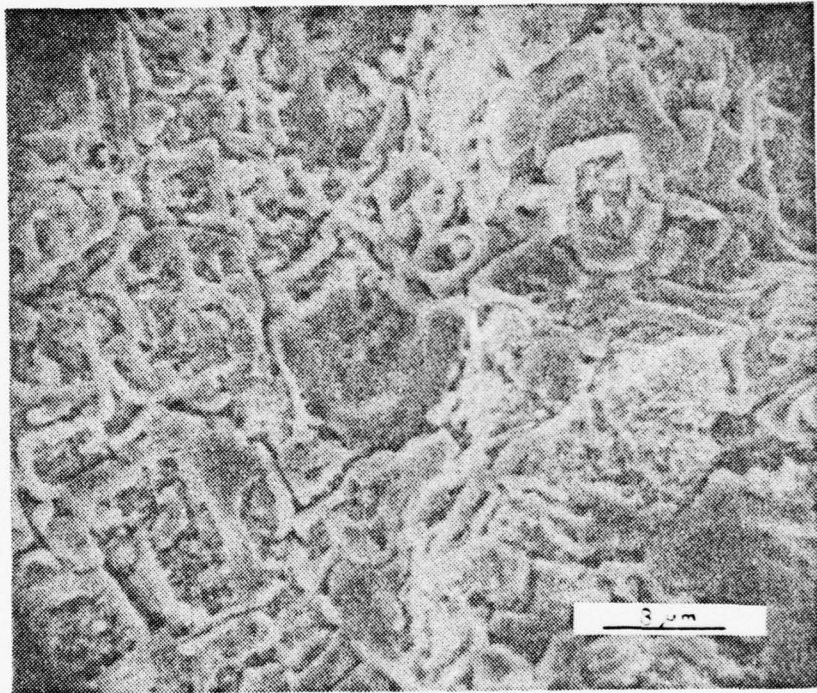

Figure 100. Lead-sulfate at the grid interface; note the transformation which has taken place. Lead-calcium PbCA#1, 50 cycles, 2200X.

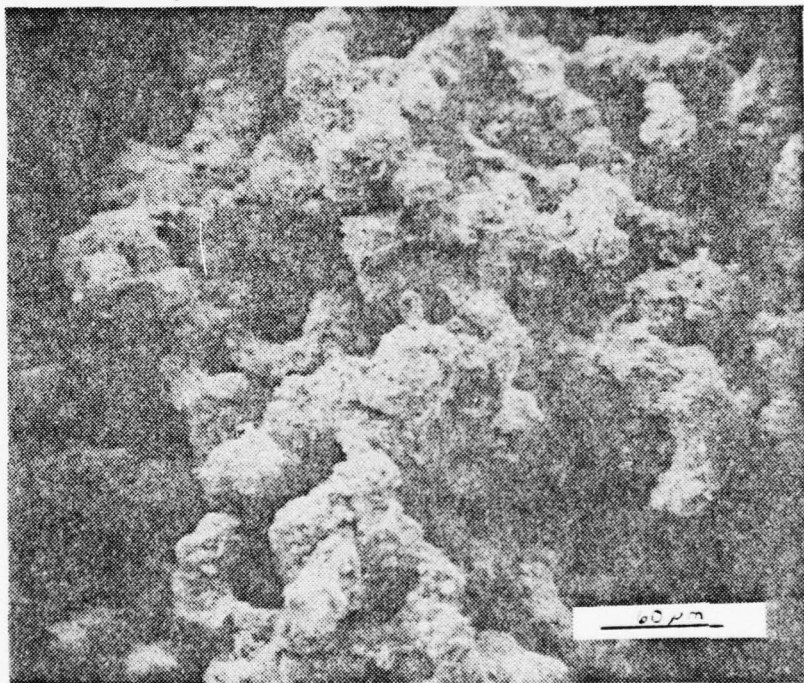

Figure 101. Fully formed coralloid structure found throughout the active material of the positive plate. Lead-calcium PbCA#1, 60 cycles, 295X.

into PbO_2 of a similar structure to that seen in the outer layers of the active material at 20 cycles (Fig. 102). No fully formed lead-sulfate crystals were seen to exist in the 60-cycle plate. X-ray diffraction showed that some lead-sulfate was present in the active material, but no evidence of the large lead-sulfate crystal observed at fewer cycles could be found by microscopic examination. Some lead-sulfate was still found to exist in a highly transformed state near the grid, upon examination of the grid-active material interface (Fig. 103).

A summary of the results from the investigation of the cycled lead-calcium type thick plate battery are as follows.

1. The coralloid structure is confirmed to exist as the end of the useful service life of the battery is approached. The coralloid structure is believed to be a prime cause of active material shedding and passivation of large amounts of active material.

2. It was observed that this thick plate battery seemed to store active material for future use as lead-sulfate in a center layer of the active material, and that this storage mechanism allowed this lead-calcium battery to be operated on a deep cycle routine with service life comparable to a lead-antimony grid battery.

3. The microstructures of the positive plate are important to the proper operation of the battery and to its cycle life.

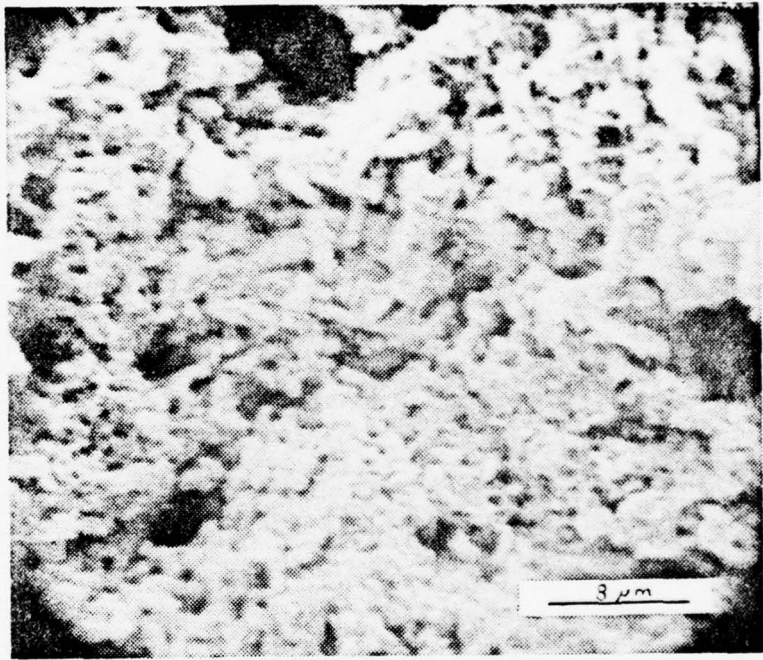

Figure 102. Active material at center of plate with little evidence of lead-sulfate being present. Lead-calcium PbCA#1, 60 cycles, 2500X.

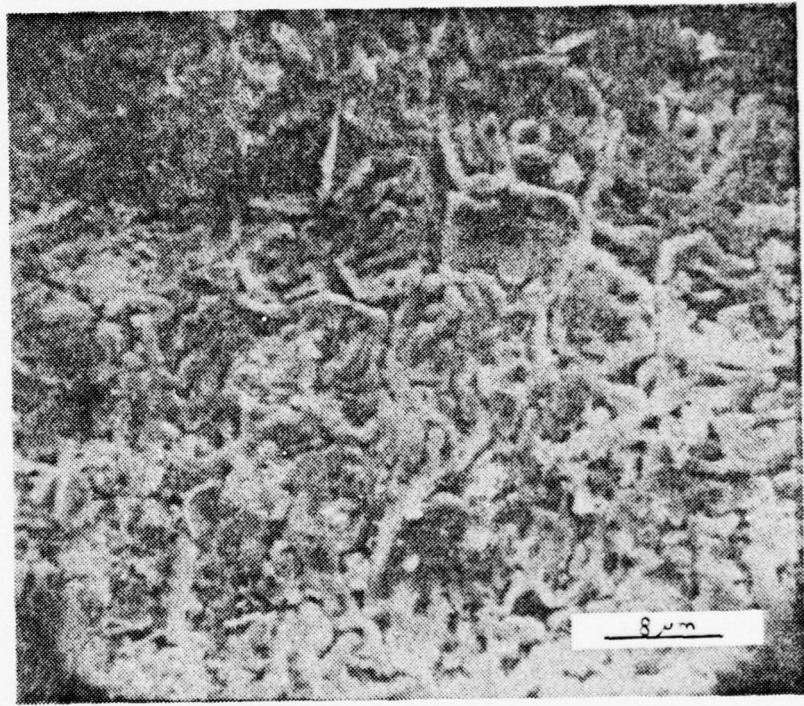

Figure 103. Lead-sulfate was still found to exist in a highly transformed state near the grid interface. Lead-calcium PbCA#1, 60 cycles, 2100X.

C. X-RAY DIFFRACTION ANALYSIS

X-ray diffraction patterns were obtained on the active material of selected samples taken from the cycled plates. Patterns were obtained for the lead-antimony active material at zero and 60 cycles, and for the lead-calcium battery at zero, 40, and 60 cycles. An attempt was made to ascertain the make up of the active material at these stages in cycle life. The diffraction patterns were recorded with Ni filtered $\text{CuK}\alpha$ radiation at a goniometer speed of $.5^\circ$ $2\theta/\text{min}$. The intensity of the strongest line in each pattern was taken as 100. The patterns were run between 10° - 2θ to 110° - 2θ corresponding to a d spacing down to $.8 \text{ \AA}$.

The major diagnostic reflections used for identification of β -lead-dioxide, α -lead-dioxide, and lead sulfate are shown in Figure 104.

The zero cycle patterns for both battery types (Figs. 105, 106) indicated only the presence of tetragonal lead dioxide ($\beta\text{-PbO}_2$) as the major constituent of the active material before cycling. After cycling the presence of detectable lead-sulfate lines was noted in the patterns of the cycled plates (Figs. 107, 108, 109). This result was not unexpected in that Tudor, Weisstuch, and Davang [15,16,17] reported that lead-sulfate existed within the positive plates in fully charged state. No reflections were obtained indicating the presence of α -lead dioxide.

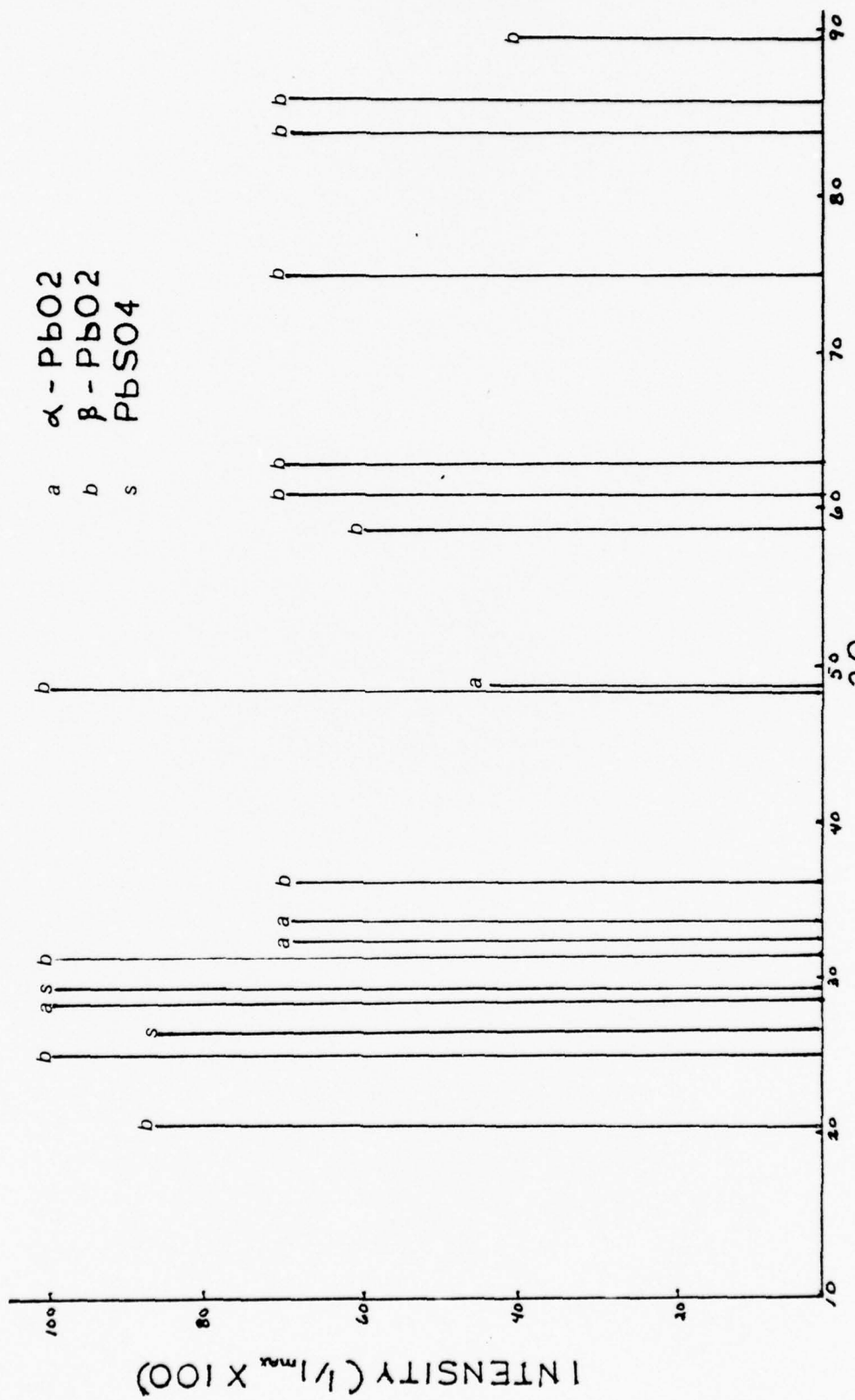

RELATIVE INTENSITY VS 2θ FOR MAJOR PEAKS
FIGURE 104

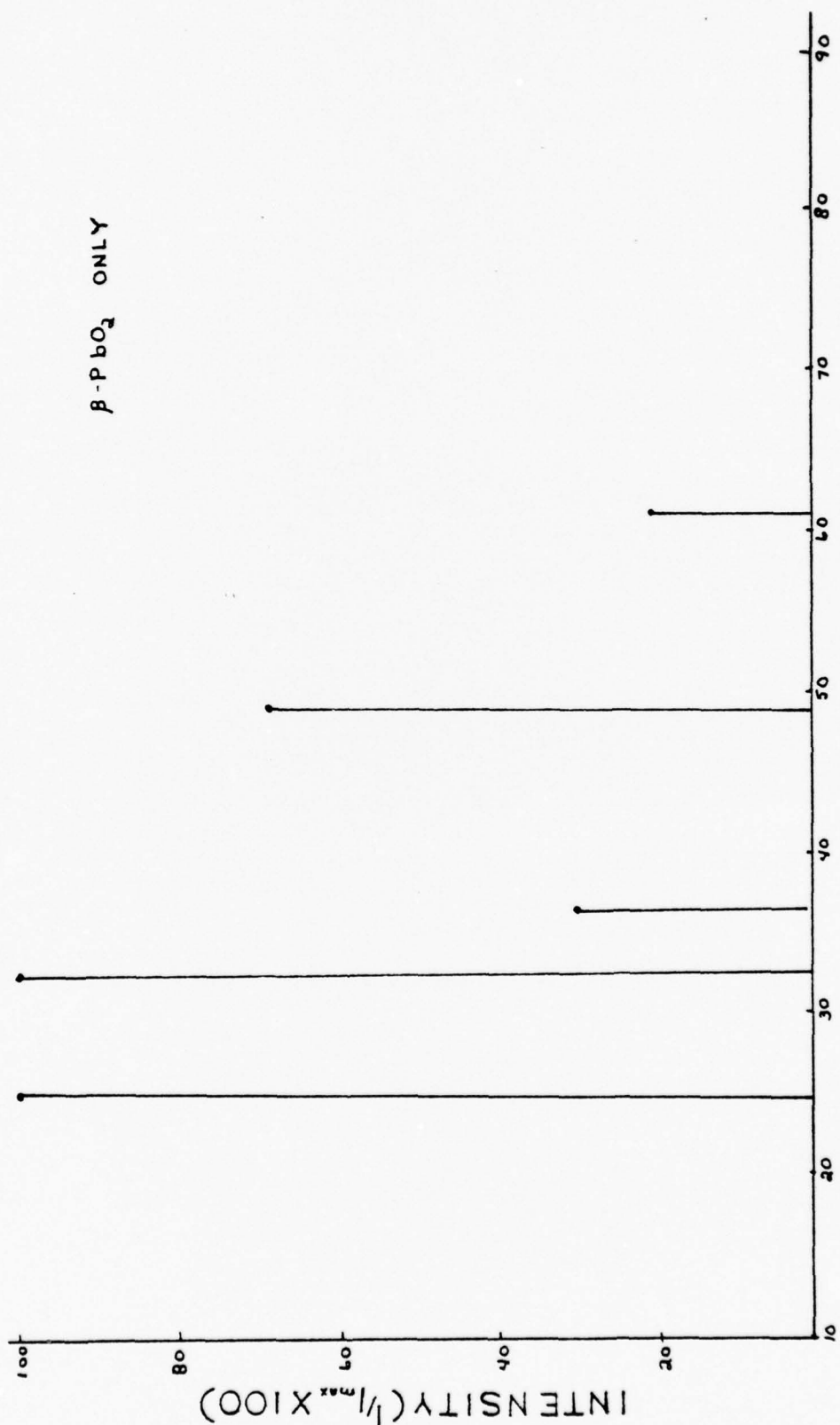

RELATIVE INTENSITY VS 2θ FOR 0 CYCLE LEAD ANTIMONY

FIGURE 105

β -PbO₂ ONLY

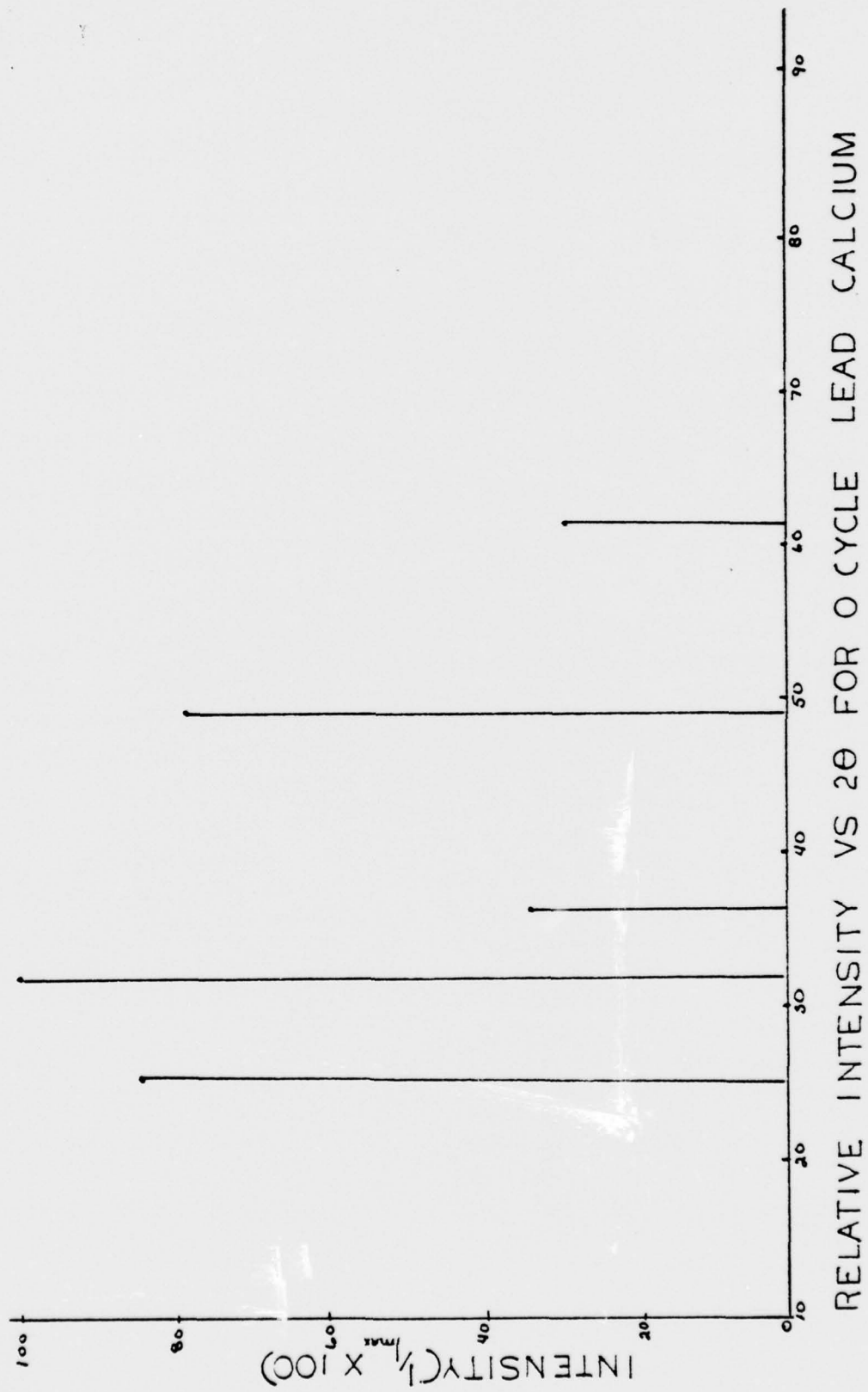
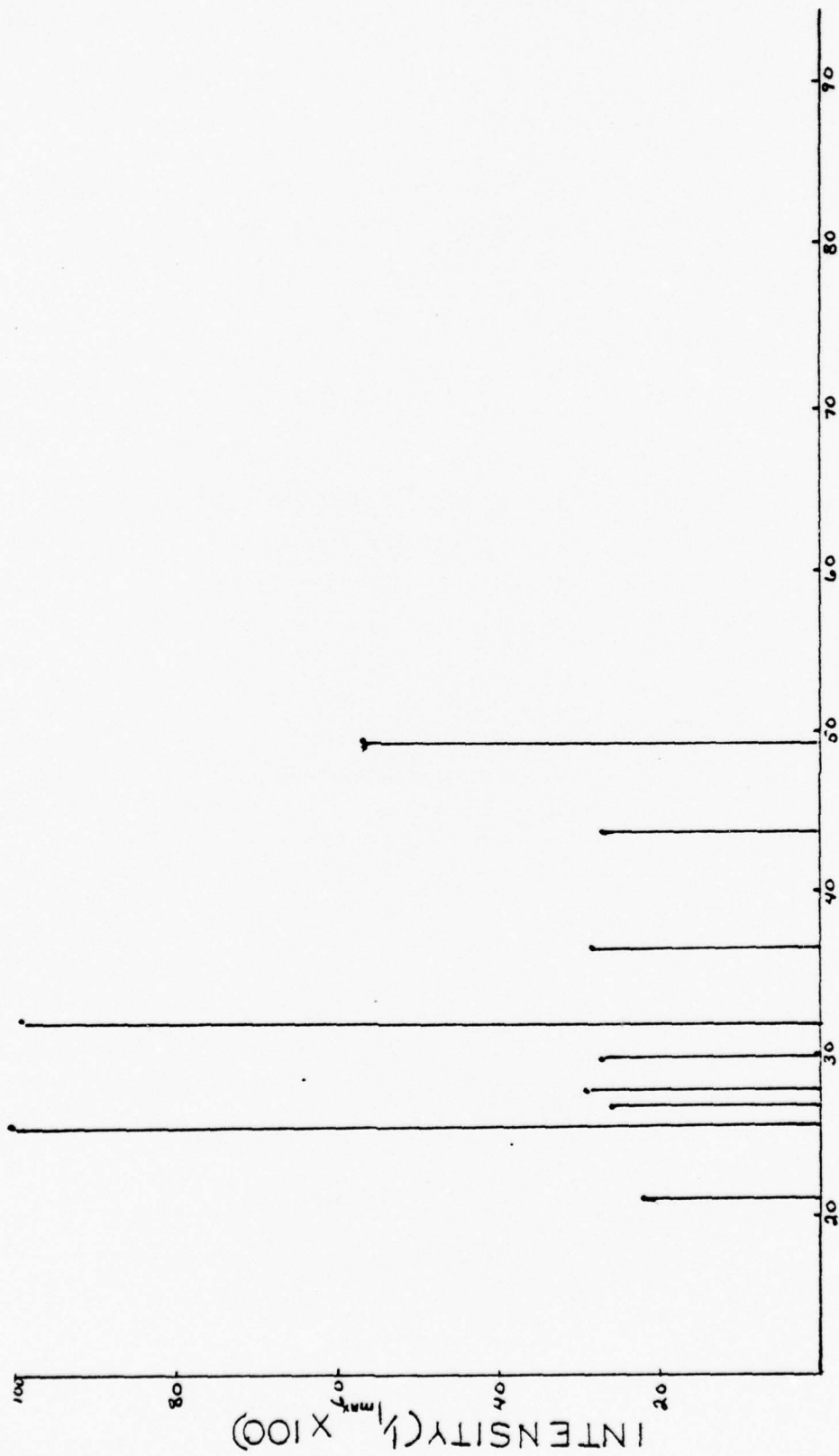

FIGURE 106

β -PbO₂ PRESENT
PbSO₄



RELATIVE INTENSITY VS 2θ FOR 60 CYCLE LEAD ANTIMONY

FIGURE 107

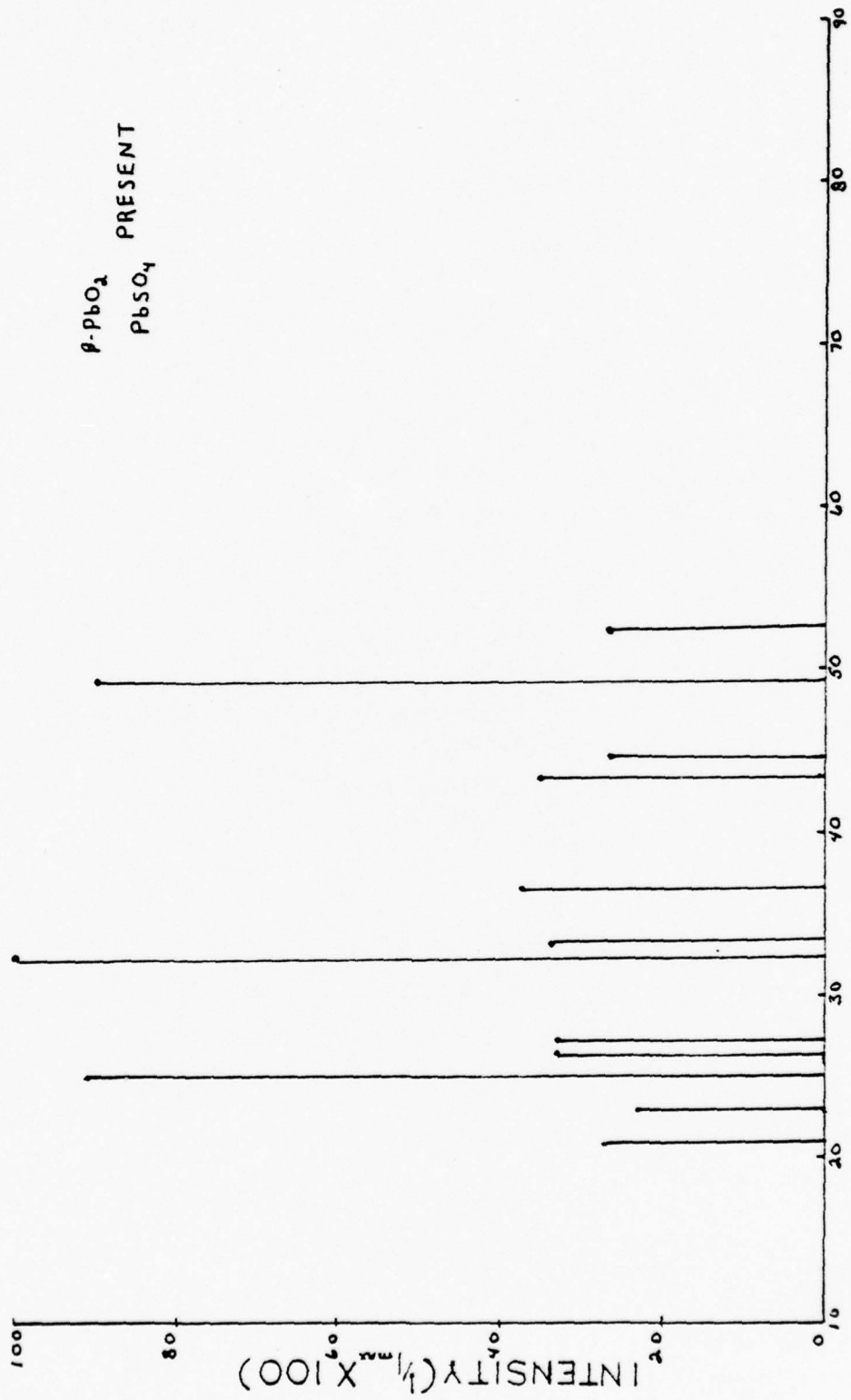

RELATIVE INTENSITY VS 2θ FOR 40 CYCLE LEAD CALCIUM

FIGURE 108

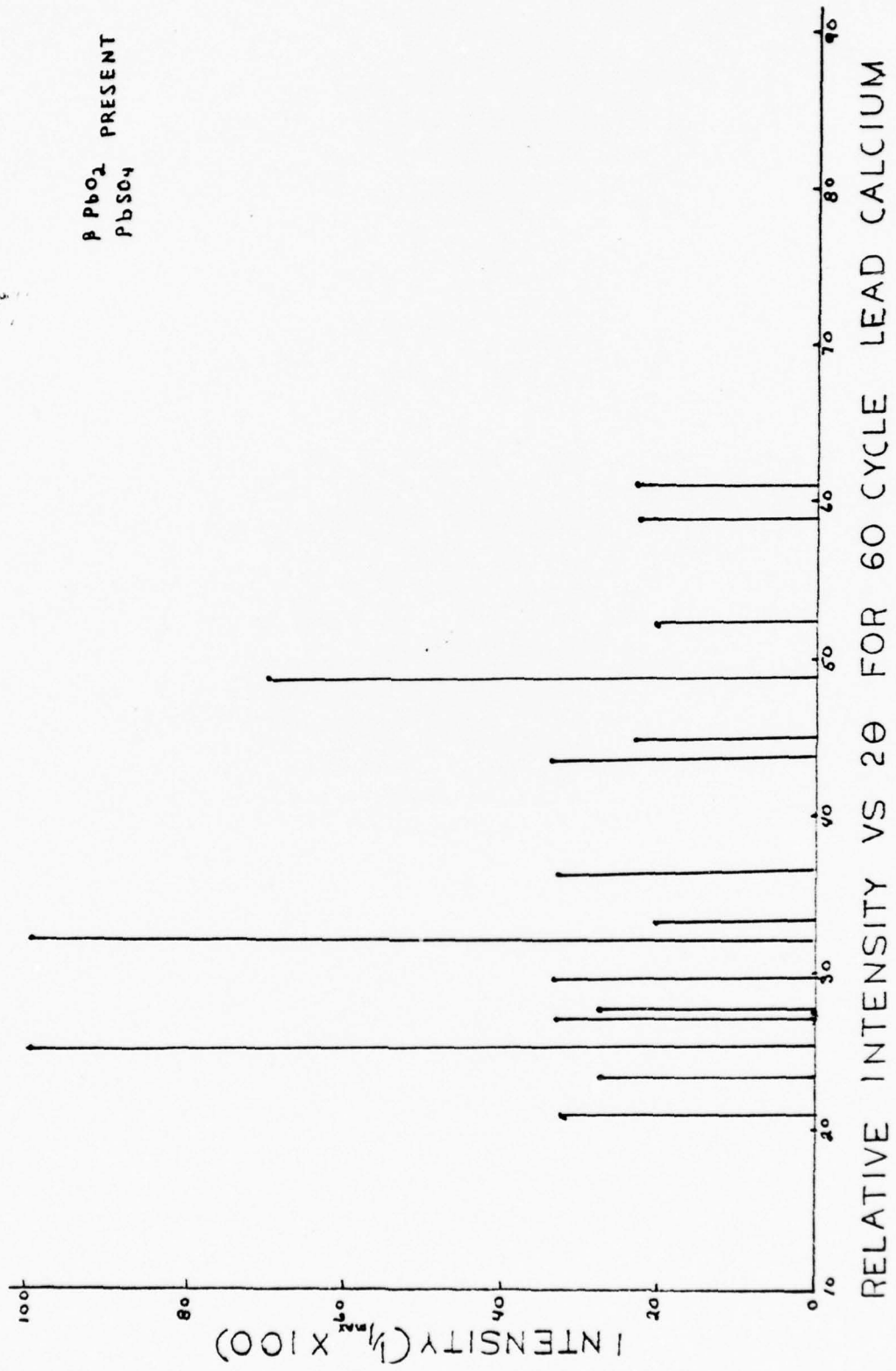

FIGURE 109

IV. CONCLUSIONS

The following conclusions have been reached as a direct result of this investigation.

1. The coralloid active material microstructure has been shown to develop in both the lead-antimony and lead-calcium grid batteries as the end of useful service life is approached. This structure is believed to be a definite precedent to failure of the positive plate in a cycling battery and a primary cause for increased shedding of the active material as failure is approached.

2. Current paths through the active material are believed to be a contributing factor to the formation of the coralloid microstructure, along with the ideas put forth by Simon [Ref. 32] as to the formation processes of this microstructure.

3. Creditable service life can be obtained from a calcium alloyed grid battery, comparable to that of an antimony alloyed grid battery. The mechanism for this ability to maintain capacity on a cycle routine is as follows. A reserve of active material is stored as lead-sulfate at the center of the positive plate during initial cycling. This reserve is not transformed by charging until the surface layers of active material are worn out or passivated and begin to shed. As this occurs the reserve is transformed into PbO_2 and enters the discharge-charge reactions as new active material,

maintaining the capacity of the battery. Only as the reserve is completely transformed does the battery show signs of decreasing capacity.

4. Two possible mechanisms for the coralloid role in capacity loss were deduced. First, its appearance as a nodular network suggests that these nodules are primary candidates for shedding as this structure is formed near the surface of the plate. Additionally, there is mechanism of passivation of the active material of this structure by the formation of sulfate over its surface, thus encapsulating the active material and isolating it from further reaction during discharge.

5. The presence of a needle-like dendritic crystal formation was noted in both the lead-calcium and lead-antimony type batteries. This network disappeared in the lead-antimony type as failure of the plate approached, suggesting that this may also be related to successful performance of the battery.

6. It is believed that the microstructures of the positive plate are of extreme importance to successful maintenance of capacity of batteries, and deserves further study of these microstructures and their effects upon the performance of the battery in service.

V. RECOMMENDATIONS

The results of this study represent an initial step in the study of the lead-acid battery system at the Naval Postgraduate School. Utilization of the scanning electron microscope (SEM) as the primary analysis instrument has again shown its usefulness as a research instrument. More work is necessary in this field and the following are suggested areas of possible future research:

1. The coralloid structure appears to be a primary candidate for failure of the active material of the positive plate. Further studies into the causes of its formation and its composition are seen as areas of productive research. This could lead to the elimination of this microstructure and increased life of the battery.

2. The plates studied in this report were all observed in the fully charged state. A study of the plate at different charged states, and even completely discharged states, would add significant knowledge to this area of research.

3. In order to gain a better understanding of the effects of different discharge rates on the positive plate morphology, it is recommended that plate microstructure be examined at various rates of discharge.

4. The testing procedures used in this research evolved over the course of the testing, and some inconsistencies associated with procedures and this technique development

are present in the results; it is highly recommended that these studies be repeated to confirm the validity of these results and test procedures.

5. In the limited time available for a thesis research project at the Naval Postgraduate School, new accelerated testing procedures need to be developed so meaningful results can be obtained within this time frame, giving enough time for a thorough analysis of the results of the tests.

TABLE I
Maximum Impurity Levels in Water

	Percent
Suspended matter	trace
total solids	0.01
calcium and magnesium oxide	0.004
iron	0.00005
copper	0.00025
chlorine	0.0005
nickel	0.00002
organic and volatile matter	0.005
ammonia as NH ₄	0.0008
nitrites as NO ₂	0.0005
nitrites as NO ₃	0.001

TABLE II
Maximum Impurity Levels in Sulfuric Acid

	Percent		Percent
Antimony	.0001	Platinum	none
Arsenic	.0001	Selenium	.002
Chlorine	.001	Sulfurous acid	.004
Nickel	.0001	Zinc	.004
Copper	.005	Ammonium	.001
Iron	.005	Fired residue	.03
Manganese	.00002		
Nitrates	.0005		

TABLE III

Temp °F	Terminal Voltage (volts)
65	7.275
66	7.266
67	7.257
68	7.248
69	7.239
70	7.230
71	7.221
72	7.212
73	7.209
74	7.194
75	7.185
76	7.176
77	7.107
78	7.158
79	7.149
80	7.140

APPENDIX A
CONTROLLED CURRENT DISCHARGE UNIT

T. Christian
Department of Mechanical Engineering
Naval Postgraduate School, Monterey, CA

This device is basically a voltage controlled current generator designed to provide a varying load to an external voltage and current source such as a battery. The principle is to provide a constant voltage across a known fixed load resistor (or load bank) thereby providing a fixed current.

The external source (battery) is connected in series with the control element and load resistor. The control element will vary its resistance in order to keep the voltage across the load constant. Since the current is the same in all parts of a series circuit (Kirchoff's Law) the current will be controlled by the E/R relationship (Ohm's Law).

The control element can control between 2.00 volts and 5.5 volts with better than .1% regulation and will respond in less than 15 microseconds to dynamic variations in the source (battery). In view of this, load resistors (or load bank) must be selected to insure the device is working within its limitations.

In addition to control over the load a drop out feature has been included in the design. A voltage comparator is used to sense the source (battery) voltage and compare it to a preselected adjustable reference voltage. When the

source voltage drops to 5 millivolts below the reference voltage a relay opens and disables the control element. A LED (light emitting diode) on the face of the device is inactivated to advise the operator of the disabled condition of the control element. The control element must be reset manually to restart the cycle. It will not restart regardless of the voltage of the source until it has been manually reset.

SPECIFICATIONS:

Voltage: 2.00 to 5.5 Volts D.C.

Current: to 4.5 amps

Headroom: .6 to 19 Volts D.C.

Dynamic Response: 15 microseconds

Dropout Differential: less than 5 millivolts

* Headroom is defined as the minimum differential in volts between the source (battery) and the controlled voltage across the load.

For further information contact T. Christian at the above address.

(This device was designed for use by Lieutenant Pokorny in conducting experiments for his Master's Degree Thesis titled: Study of the Cyclic Performance of Submarine Type Lead-Acid Storage Batteries by Examination of the Positive Plate Structures.

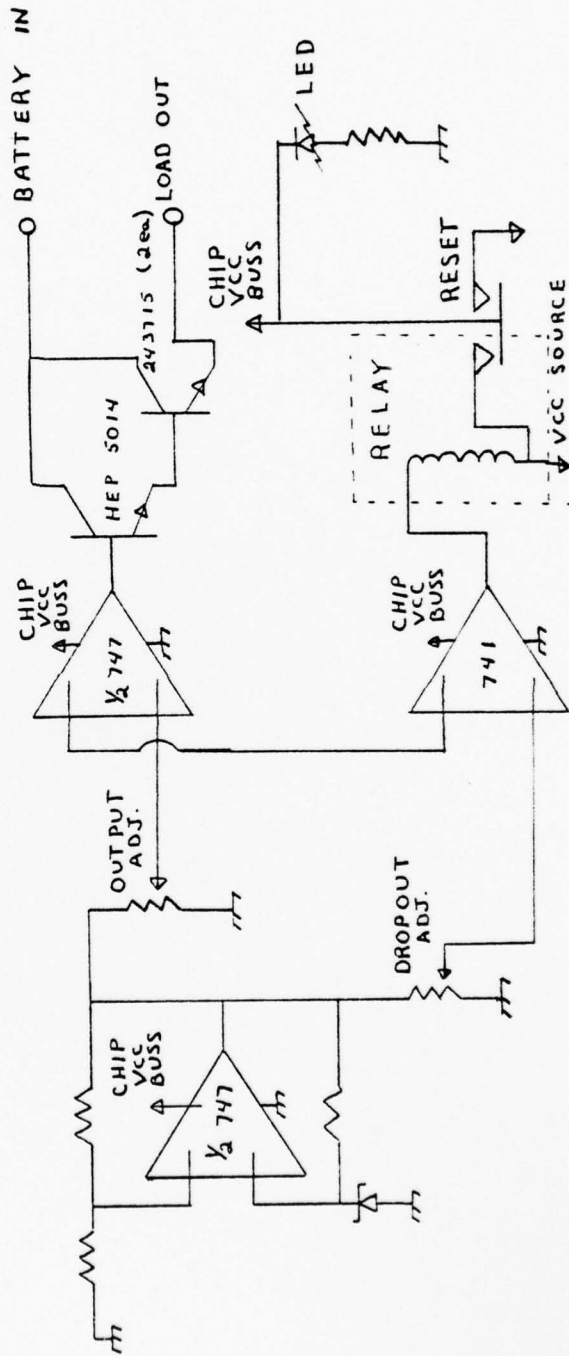
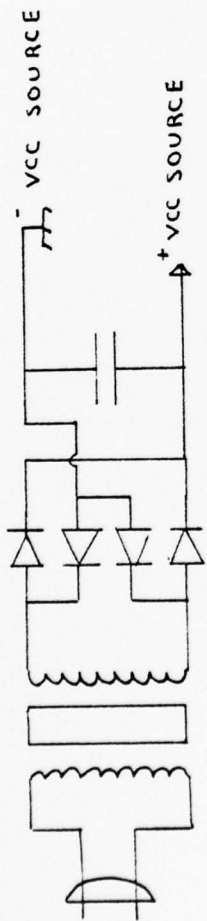

DISCHARGE UNIT

FIGURE 110

APPENDIX B

CYCLE HISTORY OF PBSB # 1

DISCHARGE NUMBER 1
 DISCHARGE CURRENT 1.00 DURATION OF DISCHARGE 0.0 HR.
 RECORDED CELL # 1
 START OF DISCHARGE BATTERY PARAMETERS
 TOTAL BATTERY VOLTAGE 6.643
 INDIVIDUAL CELL VOLTAGES SPECIFIC GRAVITY
 CELL# 1 2.222 1.262
 CELL# 2 2.220 1.260
 CELL#30 2.219 1.259

THE RECORDED CELL CONTROLLED THE DISCHARGE
 END OF DISCHARGE BATTERY PARAMETERS
 BATTERY CUTOFF VOLTAGE 0.0 REC. CELL CUTOFF VOLTAGE 0.0
 CAPACITY OF BATTERY FOR THIS DISCHARGE 0.0 PERCENT
 TOTAL BATTERY VOLTAGE 5.845
 INDIVIDUAL CELL VOLTAGES SPECIFIC GRAVITY
 CELL# 1 1.967 1.253
 CELL# 2 1.948 1.247
 CELL# 3 1.925 1.240

END OF CHARGE BATTERY ON OPEN CIRCUIT
 CHARGE NUMBER 1
 TOTAL BATTERY VOLTAGE 6.432
 INDIVIDUAL CELL VOLTAGES SPECIFIC GRAVITY
 CELL# 1 2.219 1.262
 CELL# 2 2.211 1.260
 CELL# 3 2.202 1.270

DISCHARGE NUMBER 2
 DISCHARGE CURRENT 1.00 DURATION OF DISCHARGE 0.0 HR.
 RECORDED CELL # 1
 START OF DISCHARGE BATTERY PARAMETERS
 TOTAL BATTERY VOLTAGE 6.422
 INDIVIDUAL CELL VOLTAGES SPECIFIC GRAVITY
 CELL# 1 2.148 1.266
 CELL# 2 2.147 1.268
 CELL# 3 2.138 1.263

THE RECORDED CELL CONTROLLED THE DISCHARGE
 END OF DISCHARGE BATTERY PARAMETERS
 BATTERY CUTOFF VOLTAGE 0.0 REC. CELL CUTOFF VOLTAGE 0.0
 CAPACITY OF BATTERY FOR THIS DISCHARGE 0.0 PERCENT
 TOTAL BATTERY VOLTAGE 5.915
 INDIVIDUAL CELL VOLTAGES SPECIFIC GRAVITY
 CELL# 1 1.985 1.238
 CELL# 2 1.974 1.242
 CELL# 3 1.956 1.215

END OF CHARGE BATTERY ON OPEN CIRCUIT
 CHARGE NUMBER 2
 TOTAL BATTERY VOLTAGE 6.404
 INDIVIDUAL CELL VOLTAGES SPECIFIC GRAVITY
 CELL# 1 2.136 1.264
 CELL# 2 2.133 1.264
 CELL# 3 2.130 1.271

DISCHARGE NUMBER 3
 DISCHARGE CURRENT 4.50 DURATION OF DISCHARGE 4.17 HR.

RECORDED CELL # 1
START OF DISCHARGE BATTERY PARAMETERS
TOTAL BATTERY VOLTAGE 6.470
INDIVIDUAL CELL VOLTAGES SPECIFIC GRAVITY
CELL# 1 2.124 1.266
CELL# 2 2.127 1.265
CELL# 3 2.119 1.266

THE RECORDED CELL CONTROLLED THE DISCHARGE
END OF DISCHARGE BATTERY PARAMETERS
BATTERY CUTOFF VOLTAGE 4.50 REC. CELL CUTOFF VOLTAGE 1.50
CAPACITY OF BATTERY FOR THIS DISCHARGE 100.00 PERCENT
TOTAL BATTERY VOLTAGE 5.873
INDIVIDUAL CELL VOLTAGES SPECIFIC GRAVITY
CELL# 1 1.975 1.230
CELL# 2 1.963 1.230
CELL# 3 1.948 1.225

DISCHARGE NUMBER 4
DISCHARGE CURRENT 4.50 DURATION OF DISCHARGE 0.0 HR.
RECORDED CELL # 1
START OF DISCHARGE BATTERY PARAMETERS
TOTAL BATTERY VOLTAGE 6.449
INDIVIDUAL CELL VOLTAGES SPECIFIC GRAVITY
CELL# 1 2.154 1.265
CELL# 2 2.151 1.265
CELL# 3 2.144 1.268

THE RECORDED CELL CONTROLLED THE DISCHARGE
END OF DISCHARGE BATTERY PARAMETERS
BATTERY CUTOFF VOLTAGE 0.0 REC. CELL CUTOFF VOLTAGE 0.0
CAPACITY OF BATTERY FOR THIS DISCHARGE 0.0 PERCENT
TOTAL BATTERY VOLTAGE 5.837
INDIVIDUAL CELL VOLTAGES SPECIFIC GRAVITY
CELL# 1 1.968 1.225
CELL# 2 1.944 1.227
CELL# 3 1.925 1.220

END OF CHARGE BATTERY ON OPEN CIRCUIT
CHARGE NUMBER 4
TOTAL BATTERY VOLTAGE 6.590
INDIVIDUAL CELL VOLTAGES SPECIFIC GRAVITY
CELL# 1 2.200 1.263
CELL# 2 2.195 1.265
CELL# 3 2.195 1.263

DISCHARGE NUMBER 5
DISCHARGE CURRENT 3.40 DURATION OF DISCHARGE 5.97 HR.
RECORDED CELL # 1
START OF DISCHARGE BATTERY PARAMETERS
TOTAL BATTERY VOLTAGE 6.453
INDIVIDUAL CELL VOLTAGES SPECIFIC GRAVITY
CELL# 1 2.153 1.262
CELL# 2 2.154 1.264
CELL# 3 2.146 1.262

THE RECORDED CELL CONTROLLED THE DISCHARGE
END OF DISCHARGE BATTERY PARAMETERS
BATTERY CUTOFF VOLTAGE 5.10 REC. CELL CUTOFF VOLTAGE 1.75
CAPACITY OF BATTERY FOR THIS DISCHARGE 102.95 PERCENT
TOTAL BATTERY VOLTAGE 5.895
INDIVIDUAL CELL VOLTAGES SPECIFIC GRAVITY
CELL# 1 1.965 1.220
CELL# 2 1.942 1.227
CELL# 3 1.930 0.210

DISCHARGE NUMBER 6
DISCHARGE CURRENT 4.50 DURATION OF DISCHARGE 0.0 HR.
RECORDED CELL # 1
START OF DISCHARGE BATTERY PARAMETERS
TOTAL BATTERY VOLTAGE 6.768
INDIVIDUAL CELL VOLTAGES SPECIFIC GRAVITY
CELL# 1 2.261 1.268
CELL# 2 2.251 1.270
CELL# 3 2.256 1.262

THE RECORDED CELL CONTROLLED THE DISCHARGE
END OF DISCHARGE BATTERY PARAMETERS
BATTERY CUTOFF VOLTAGE 0.0 REC. CELL CUTOFF VOLTAGE 0.0
CAPACITY OF BATTERY FOR THIS DISCHARGE 0.0 PERCENT
TOTAL BATTERY VOLTAGE 6.201
INDIVIDUAL CELL VOLTAGES SPECIFIC GRAVITY
CELL# 1 2.068 1.219
CELL# 2 2.071 1.222
CELL# 3 2.062 1.212

DISCHARGE NUMBER 7
DISCHARGE CURRENT 2.30 DURATION OF DISCHARGE 0.0 HR.
RECORDED CELL # 1
START OF DISCHARGE BATTERY PARAMETERS
TOTAL BATTERY VOLTAGE 6.544
INDIVIDUAL CELL VOLTAGES SPECIFIC GRAVITY
CELL# 1 2.212 1.252
CELL# 2 2.164 1.254
CELL# 3 2.168 1.252

THE RECORDED CELL CONTROLLED THE DISCHARGE
END OF DISCHARGE BATTERY PARAMETERS
BATTERY CUTOFF VOLTAGE 0.0 REC. CELL CUTOFF VOLTAGE 0.0
CAPACITY OF BATTERY FOR THIS DISCHARGE 0.0 PERCENT
TOTAL BATTERY VOLTAGE 6.219
INDIVIDUAL CELL VOLTAGES SPECIFIC GRAVITY
CELL# 1 2.061 1.224
CELL# 2 2.069 1.216
CELL# 3 2.700 1.219

DISCHARGE NUMBER 8
DISCHARGE CURRENT 3.40 DURATION OF DISCHARGE 6.26 HR.
RECORDED CELL # 1
START OF DISCHARGE BATTERY PARAMETERS
TOTAL BATTERY VOLTAGE 6.761
INDIVIDUAL CELL VOLTAGES SPECIFIC GRAVITY
CELL# 1 2.280 1.264
CELL# 2 2.260 1.257
CELL# 3 2.260 1.259

END OF DISCHARGE BATTERY PARAMETERS
BATTERY CUTOFF VOLTAGE 4.60 REC. CELL CUTOFF VOLTAGE 1.80
CAPACITY OF BATTERY FOR THIS DISCHARGE 108.03 PERCENT
TOTAL BATTERY VOLTAGE 6.199
INDIVIDUAL CELL VOLTAGES SPECIFIC GRAVITY
CELL# 1 2.069 1.216
CELL# 2 2.064 1.213
CELL# 3 2.061 1.210

DISCHARGE NUMBER 9
DISCHARGE CURRENT 3.40 DURATION OF DISCHARGE 6.07 HR.
RECORDED CELL # 1
START OF DISCHARGE BATTERY PARAMETERS
TOTAL BATTERY VOLTAGE 6.586
INDIVIDUAL CELL VOLTAGES SPECIFIC GRAVITY

CELL # 1 2.193 1.273
CELL # 2 2.196 1.262
CELL # 3 2.194 1.265

THE RECORDED CELL CONTROLLED THE DISCHARGE
END OF DISCHARGE BATTERY PARAMETERS
BATTERY CUTOFF VOLTAGE 4.60 REC. CELL CUTOFF VOLTAGE 1.00
CAPACITY OF BATTERY FOR THIS DISCHARGE 104.68 PERCENT
TOTAL BATTERY VOLTAGE 6.214
INDIVIDUAL CELL VOLTAGES SPECIFIC GRAVITY

CELL # 1 2.071 1.215
CELL # 2 2.074 1.216
CELL # 3 2.064 1.209

DISCHARGE NUMBER 10
DISCHARGE CURRENT 3.40 DURATION OF DISCHARGE 6.02 HR.

RECORDED CELL # 1
START OF DISCHARGE BATTERY PARAMETERS

TOTAL BATTERY VOLTAGE 6.561
INDIVIDUAL CELL VOLTAGES SPECIFIC GRAVITY
CELL # 1 2.183 1.269
CELL # 2 2.188 1.266
CELL # 3 2.185 1.265

END OF DISCHARGE BATTERY PARAMETERS
BATTERY CUTOFF VOLTAGE 4.60 REC. CELL CUTOFF VOLTAGE 1.80
CAPACITY OF BATTERY FOR THIS DISCHARGE 103.82 PERCENT
TOTAL BATTERY VOLTAGE 6.220
INDIVIDUAL CELL VOLTAGES SPECIFIC GRAVITY

CELL # 1 2.071 1.216
CELL # 2 2.078 1.222
CELL # 3 2.065 1.213

DISCHARGE NUMBER 11
DISCHARGE CURRENT 3.40 DURATION OF DISCHARGE 5.08 HR.

RECORDED CELL # 1
START OF DISCHARGE BATTERY PARAMETERS

TOTAL BATTERY VOLTAGE 6.890
INDIVIDUAL CELL VOLTAGES SPECIFIC GRAVITY
CELL #10 2.319 1.271
CELL #20 2.287 1.271
CELL #40 2.204 1.258

END OF DISCHARGE BATTERY PARAMETERS
BATTERY CUTOFF VOLTAGE 4.60 REC. CELL CUTOFF VOLTAGE 1.91
CAPACITY OF BATTERY FOR THIS DISCHARGE 87.72 PERCENT
TOTAL BATTERY VOLTAGE 6.225
INDIVIDUAL CELL VOLTAGES SPECIFIC GRAVITY

CELL # 1 2.076 1.224
CELL # 2 2.088 1.234
CELL # 4 2.061 1.219

DISCHARGE NUMBER 12
DISCHARGE CURRENT 2.80 DURATION OF DISCHARGE 6.83 HR.

RECORDED CELL # 1
START OF DISCHARGE BATTERY PARAMETERS

TOTAL BATTERY VOLTAGE 6.970
INDIVIDUAL CELL VOLTAGES SPECIFIC GRAVITY
CELL # 1 2.343 1.270
CELL # 2 2.360 1.272
CELL # 4 2.307 1.262

END OF DISCHARGE BATTERY PARAMETERS
BATTERY CUTOFF VOLTAGE 4.60 REC. CELL CUTOFF VOLTAGE 1.95
CAPACITY OF BATTERY FOR THIS DISCHARGE 93.82 PERCENT
TOTAL BATTERY VOLTAGE 6.223
INDIVIDUAL CELL VOLTAGES SPECIFIC GRAVITY

CELL# 1 2.071 1.224
CELL# 2 2.083 1.229
CELL# 4 2.064 1.214

DISCHARGE NUMBER 13
DISCHARGE CURRENT 3.45 DURATION OF DISCHARGE 5.18 HR.
RECORDED CELL # 1
START OF DISCHARGE BATTERY PARAMETERS
TOTAL BATTERY VOLTAGE 6.558
INDIVIDUAL CELL VOLTAGES SPECIFIC GRAVITY
CELL# 1 2.197 1.266
CELL# 2 2.203 1.276
CELL# 4 2.141 1.270

END OF DISCHARGE BATTERY PARAMETERS
BATTERY CUTOFF VOLTAGE 4.60 REC. CELL CUTOFF VOLTAGE 1.87
CAPACITY OF BATTERY FOR THIS DISCHARGE 90.99 PERCENT
TOTAL BATTERY VOLTAGE 6.243
INDIVIDUAL CELL VOLTAGES SPECIFIC GRAVITY
CELL# 1 2.080 1.224
CELL# 2 2.088 1.239
CELL# 4 2.075 1.224

DISCHARGE NUMBER 14
DISCHARGE CURRENT 3.40 DURATION OF DISCHARGE 5.22 HR.
RECORDED CELL # 1
START OF DISCHARGE BATTERY PARAMETERS
TOTAL BATTERY VOLTAGE 6.992
INDIVIDUAL CELL VOLTAGES SPECIFIC GRAVITY
CELL# 1 2.352 1.255
CELL# 2 2.340 1.267
CELL# 4 2.300 1.264

END OF DISCHARGE BATTERY PARAMETERS
BATTERY CUTOFF VOLTAGE 4.50 REC. CELL CUTOFF VOLTAGE 1.85
CAPACITY OF BATTERY FOR THIS DISCHARGE 90.01 PERCENT
TOTAL BATTERY VOLTAGE 6.098
INDIVIDUAL CELL VOLTAGES SPECIFIC GRAVITY
CELL# 1 2.028 1.224
CELL# 2 2.020 1.239
CELL# 4 1.950 1.222

DISCHARGE NUMBER 15
DISCHARGE CURRENT 3.45 DURATION OF DISCHARGE 5.33 HR.
RECORDED CELL # 1
START OF DISCHARGE BATTERY PARAMETERS
TOTAL BATTERY VOLTAGE 6.968
INDIVIDUAL CELL VOLTAGES SPECIFIC GRAVITY
CELL# 1 2.332 1.263
CELL# 2 2.331 1.274
CELL# 4 2.280 1.267

END OF DISCHARGE BATTERY PARAMETERS
BATTERY CUTOFF VOLTAGE 4.50 REC. CELL CUTOFF VOLTAGE 1.90
CAPACITY OF BATTERY FOR THIS DISCHARGE 93.63 PERCENT
TOTAL BATTERY VOLTAGE 6.235
INDIVIDUAL CELL VOLTAGES SPECIFIC GRAVITY
CELL# 1 2.077 1.219
CELL# 2 2.038 1.239
CELL# 4 2.070 1.224

DISCHARGE NUMBER 16
DISCHARGE CURRENT 3.45 DURATION OF DISCHARGE 5.10 HR.
RECORDED CELL # 4
START OF DISCHARGE BATTERY PARAMETERS

TOTAL BATTERY VOLTAGE 6.705
INDIVIDUAL CELL VOLTAGES SPECIFIC GRAVITY
CELL# 1 2.248 1.264
CELL# 2 2.248 1.274
CELL# 4 2.206 1.261

THE RECORDED CELL CONTROLLED THE DISCHARGE
END OF DISCHARGE BATTERY PARAMETERS
BATTERY CUTOFF VOLTAGE 4.98 REC. CELL CUTOFF VOLTAGE 1.15
CAPACITY OF BATTERY FOR THIS DISCHARGE 89.54 PERCENT
TOTAL BATTERY VOLTAGE 6.242
INDIVIDUAL CELL VOLTAGES SPECIFIC GRAVITY
CELL# 1 2.081 1.224
CELL# 2 2.092 1.234
CELL# 4 2.069 1.217

DISCHARGE NUMBER 17
DISCHARGE CURRENT 1.00 DURATION OF DISCHARGE 0.0 HR.
RECORDED CELL # 1
START OF DISCHARGE BATTERY PARAMETERS
TOTAL BATTERY VOLTAGE 6.739
INDIVIDUAL CELL VOLTAGES SPECIFIC GRAVITY
CELL# 1 2.231 1.263
CELL# 2 2.229 1.270
CELL# 4 2.264 1.259

THE RECORDED CELL CONTROLLED THE DISCHARGE
END OF DISCHARGE BATTERY PARAMETERS
BATTERY CUTOFF VOLTAGE 0.0 REC. CELL CUTOFF VOLTAGE 0.0
CAPACITY OF BATTERY FOR THIS DISCHARGE 0.0 PERCENT
TOTAL BATTERY VOLTAGE 6.030
INDIVIDUAL CELL VOLTAGES SPECIFIC GRAVITY
CELL# 1 2.600 1.226
CELL# 2 2.025 1.239
CELL# 4 1.945 1.224

DISCHARGE NUMBER 18
DISCHARGE CURRENT 2.80 DURATION OF DISCHARGE 6.92 HR.
RECORDED CELL # 1
START OF DISCHARGE BATTERY PARAMETERS
TOTAL BATTERY VOLTAGE 6.533
INDIVIDUAL CELL VOLTAGES SPECIFIC GRAVITY
CELL# 1 2.190 1.267
CELL# 2 2.200 1.276
CELL# 4 2.130 1.266

END OF DISCHARGE BATTERY PARAMETERS
BATTERY CUTOFF VOLTAGE 4.85 REC. CELL CUTOFF VOLTAGE 1.93
CAPACITY OF BATTERY FOR THIS DISCHARGE 94.96 PERCENT
TOTAL BATTERY VOLTAGE 6.242
INDIVIDUAL CELL VOLTAGES SPECIFIC GRAVITY
CELL# 1 2.080 1.223
CELL# 2 2.089 1.233
CELL# 4 2.073 1.223

DISCHARGE NUMBER 19
DISCHARGE CURRENT 2.80 DURATION OF DISCHARGE 7.13 HR.
RECORDED CELL # 1
START OF DISCHARGE BATTERY PARAMETERS
TOTAL BATTERY VOLTAGE 6.675
INDIVIDUAL CELL VOLTAGES SPECIFIC GRAVITY
CELL# 1 2.236 1.268
CELL# 2 2.242 1.275
CELL# 4 2.194 1.272

END OF DISCHARGE BATTERY PARAMETERS
BATTERY CUTOFF VOLTAGE 4.75 REC. CELL CUTOFF VOLTAGE 1.94
CAPACITY OF BATTERY FOR THIS DISCHARGE 97.94 PERCENT
TOTAL BATTERY VOLTAGE 6.139
INDIVIDUAL CELL VOLTAGES SPECIFIC GRAVITY
CELL# 1 2.050 1.224
CELL# 2 2.049 1.232
CELL# 4 2.031 1.224

DISCHARGE NUMBER 20
DISCHARGE CURRENT 2.80 DURATION OF DISCHARGE 7.28 HR.
RECORDED CELL # 1
START OF DISCHARGE BATTERY PARAMETERS
TOTAL BATTERY VOLTAGE 6.939
INDIVIDUAL CELL VOLTAGES SPECIFIC GRAVITY
CELL# 1 2.327 1.265
CELL# 2 2.317 1.267
CELL# 4 2.295 1.267

END OF DISCHARGE BATTERY PARAMETERS
BATTERY CUTOFF VOLTAGE 4.55 REC. CELL CUTOFF VOLTAGE 1.90
CAPACITY OF BATTERY FOR THIS DISCHARGE 100.00 PERCENT
TOTAL BATTERY VOLTAGE 6.255
INDIVIDUAL CELL VOLTAGES SPECIFIC GRAVITY
CELL# 1 2.085 1.216
CELL# 2 2.090 1.223
CELL# 4 2.080 1.225

DISCHARGE NUMBER 21
DISCHARGE CURRENT 3.45 DURATION OF DISCHARGE 4.75 HR.
RECORDED CELL # 1
START OF DISCHARGE BATTERY PARAMETERS
TOTAL BATTERY VOLTAGE 7.220
INDIVIDUAL CELL VOLTAGES SPECIFIC GRAVITY
CELL# 1 2.440 1.261
CELL# 5 2.380 1.257
CELL# 4 2.400 1.267

END OF DISCHARGE BATTERY PARAMETERS
BATTERY CUTOFF VOLTAGE 4.82 REC. CELL CUTOFF VOLTAGE 1.94
CAPACITY OF BATTERY FOR THIS DISCHARGE 83.39 PERCENT
TOTAL BATTERY VOLTAGE 6.108
INDIVIDUAL CELL VOLTAGES SPECIFIC GRAVITY
CELL# 1 2.067 1.235
CELL# 5 1.997 1.215
CELL# 4 2.043 1.229

DISCHARGE NUMBER 22
DISCHARGE CURRENT 3.40 DURATION OF DISCHARGE 5.57 HR.
RECORDED CELL # 1
START OF DISCHARGE BATTERY PARAMETERS
TOTAL BATTERY VOLTAGE 6.680
INDIVIDUAL CELL VOLTAGES SPECIFIC GRAVITY
CELL# 1 2.382 1.271
CELL# 5 2.254 1.255
CELL# 4 2.330 1.265

END OF DISCHARGE BATTERY PARAMETERS
BATTERY CUTOFF VOLTAGE 4.40 REC. CELL CUTOFF VOLTAGE 1.90
CAPACITY OF BATTERY FOR THIS DISCHARGE 96.05 PERCENT
TOTAL BATTERY VOLTAGE 6.243
INDIVIDUAL CELL VOLTAGES SPECIFIC GRAVITY
CELL# 1 2.094 1.234
CELL# 5 2.068 1.224
CELL# 4 2.081 1.225

DISCHARGE NUMBER 23
 DISCHARGE CURRENT 3.40 DURATION OF DISCHARGE 4.90 HR.
 RECORDED CELL # 5
 START OF DISCHARGE BATTERY PARAMETERS
 TOTAL BATTERY VOLTAGE 6.522
 INDIVIDUAL CELL VOLTAGES SPECIFIC GRAVITY
 CELL# 1 2.210 1.265
 CELL# 5 2.140 1.260
 CELL# 4 2.170 1.265

THE RECORDED CELL CONTROLLED THE DISCHARGE
 END OF DISCHARGE BATTERY PARAMETERS
 BATTERY CUTOFF VOLTAGE 4.90 REC. CELL CUTOFF VOLTAGE 1.10
 CAPACITY OF BATTERY FOR THIS DISCHARGE 84.56 PERCENT
 TOTAL BATTERY VOLTAGE 6.234
 INDIVIDUAL CELL VOLTAGES SPECIFIC GRAVITY
 CELL# 1 2.089 1.219
 CELL# 5 2.069 1.223
 CELL# 4 2.073 1.225

DISCHARGE NUMBER 24
 DISCHARGE CURRENT 2.88 DURATION OF DISCHARGE 6.57 HR.
 RECORDED CELL # 5
 START OF DISCHARGE BATTERY PARAMETERS
 TOTAL BATTERY VOLTAGE 6.607
 INDIVIDUAL CELL VOLTAGES SPECIFIC GRAVITY
 CELL# 1 2.225 1.267
 CELL# 5 2.185 1.262
 CELL# 4 2.193 1.262

THE RECORDED CELL CONTROLLED THE DISCHARGE
 END OF DISCHARGE BATTERY PARAMETERS
 BATTERY CUTOFF VOLTAGE 5.00 REC. CELL CUTOFF VOLTAGE 1.25
 CAPACITY OF BATTERY FOR THIS DISCHARGE 93.20 PERCENT
 TOTAL BATTERY VOLTAGE 6.272
 INDIVIDUAL CELL VOLTAGES SPECIFIC GRAVITY
 CELL# 1 2.098 1.246
 CELL# 5 2.085 1.225
 CELL# 4 2.089 1.231

DISCHARGE NUMBER 25
 DISCHARGE CURRENT 2.80 DURATION OF DISCHARGE 6.70 HR.
 RECORDED CELL # 5
 START OF DISCHARGE BATTERY PARAMETERS
 TOTAL BATTERY VOLTAGE 6.574
 INDIVIDUAL CELL VOLTAGES SPECIFIC GRAVITY
 CELL# 1 2.219 1.264
 CELL# 5 2.167 1.260
 CELL# 4 2.187 1.259

THE RECORDED CELL CONTROLLED THE DISCHARGE
 END OF DISCHARGE BATTERY PARAMETERS
 BATTERY CUTOFF VOLTAGE 4.75 REC. CELL CUTOFF VOLTAGE 1.00
 CAPACITY OF BATTERY FOR THIS DISCHARGE 91.99 PERCENT
 TOTAL BATTERY VOLTAGE 6.240
 INDIVIDUAL CELL VOLTAGES SPECIFIC GRAVITY
 CELL# 1 2.089 1.238
 CELL# 5 2.075 1.225
 CELL# 4 2.076 1.225

DISCHARGE NUMBER 26
 DISCHARGE CURRENT 2.80 DURATION OF DISCHARGE 6.77 HR.
 RECORDED CELL # 1
 START OF DISCHARGE BATTERY PARAMETERS
 TOTAL BATTERY VOLTAGE 6.698

AD-A033 764

NAVAL POSTGRADUATE SCHOOL MONTEREY CALIF
STUDY OF THE CYCLIC PERFORMANCE OF SUBMARINE TYPE LEAD-ACID STO--ETC(U)
SEP 76 J L POKORNY

F/G 10/3

UNCLASSIFIED

NL

3 OF 3

AD
A033764



END

DATE
FILMED
2 - 77

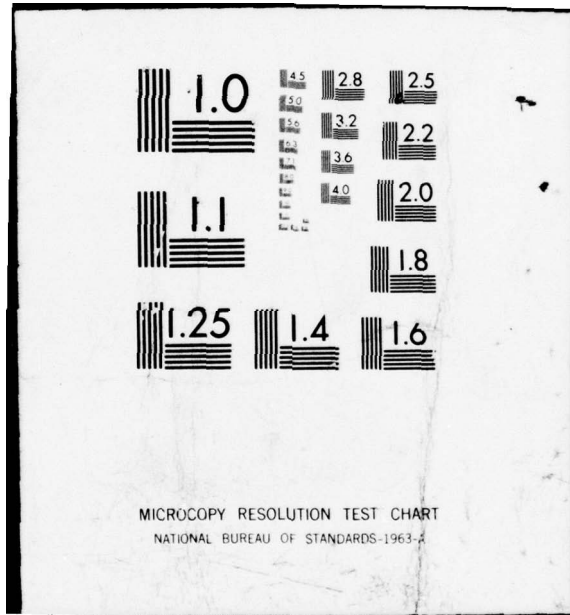

MICROCOPY RESOLUTION TEST CHART
NATIONAL BUREAU OF STANDARDS-1963-A

INDIVIDUAL CELL VOLTAGES SPECIFIC GRAVITY
CELL# 1 2.272 1.264
CELL# 5 2.203 1.262
CELL# 4 2.221 1.259

END OF DISCHARGE BATTERY PARAMETERS
BATTERY CUTOFF VOLTAGE 4.75 REC. CELL CUTOFF VOLTAGE 1.87
CAPACITY OF BATTERY FOR THIS DISCHARGE 92.90 PERCENT
TOTAL BATTERY VOLTAGE 6.247
INDIVIDUAL CELL VOLTAGES SPECIFIC GRAVITY
CELL# 1 2.088 1.239
CELL# 5 2.078 1.229
CELL# 4 2.079 1.224

DISCHARGE NUMBER 27
DISCHARGE CURRENT 2.80 DURATION OF DISCHARGE 6.93 HR.
RECORDED CELL # 1
START OF DISCHARGE BATTERY PARAMETERS
TOTAL BATTERY VOLTAGE 6.603
INDIVIDUAL CELL VOLTAGES SPECIFIC GRAVITY
CELL# 1 2.220 1.259
CELL# 5 2.187 1.262
CELL# 4 2.193 1.262

END OF DISCHARGE BATTERY PARAMETERS
BATTERY CUTOFF VOLTAGE 4.78 REC. CELL CUTOFF VOLTAGE 1.85
CAPACITY OF BATTERY FOR THIS DISCHARGE 93.82 PERCENT
TOTAL BATTERY VOLTAGE 6.243
INDIVIDUAL CELL VOLTAGES SPECIFIC GRAVITY
CELL# 1 2.087 1.239
CELL# 5 2.076 1.224
CELL# 4 2.077 1.226

DISCHARGE NUMBER 28
DISCHARGE CURRENT 3.40 DURATION OF DISCHARGE 5.17 HR.
RECORDED CELL # 1
START OF DISCHARGE BATTERY PARAMETERS
TOTAL BATTERY VOLTAGE 6.614
INDIVIDUAL CELL VOLTAGES SPECIFIC GRAVITY
CELL# 1 2.220 1.266
CELL# 5 2.187 1.259
CELL# 4 2.206 1.262

END OF DISCHARGE BATTERY PARAMETERS
BATTERY CUTOFF VOLTAGE 4.80 REC. CELL CUTOFF VOLTAGE 1.84
CAPACITY OF BATTERY FOR THIS DISCHARGE 89.15 PERCENT
TOTAL BATTERY VOLTAGE 6.247
INDIVIDUAL CELL VOLTAGES SPECIFIC GRAVITY
CELL# 1 2.078 1.232
CELL# 5 2.080 1.224
CELL# 4 2.081 1.224

DISCHARGE NUMBER 29
DISCHARGE CURRENT 3.40 DURATION OF DISCHARGE 5.25 HR.
RECORDED CELL # 1
START OF DISCHARGE BATTERY PARAMETERS
TOTAL BATTERY VOLTAGE 6.490
INDIVIDUAL CELL VOLTAGES SPECIFIC GRAVITY
CELL# 1 2.184 1.270
CELL# 5 2.149 1.268
CELL# 4 2.155 1.270

END OF DISCHARGE BATTERY PARAMETERS
BATTERY CUTOFF VOLTAGE 4.61 REC. CELL CUTOFF VOLTAGE 1.85
CAPACITY OF BATTERY FOR THIS DISCHARGE 90.60 PERCENT

TOTAL BATTERY VOLTAGE 6.252
INDIVIDUAL CELL VOLTAGES SPECIFIC GRAVITY
CELL# 1 2.088 1.237
CELL# 5 2.081 1.222
CELL# 4 2.083 1.225

DISCHARGE NUMBER 30
DISCHARGE CURRENT 3.40 DURATION OF DISCHARGE 5.28 HR.
RECORDED CELL # 1
START OF DISCHARGE BATTERY PARAMETERS
TOTAL BATTERY VOLTAGE 6.566
INDIVIDUAL CELL VOLTAGES SPECIFIC GRAVITY
CELL# 1 2.178 1.270
CELL# 5 2.193 1.266
CELL# 4 2.187 1.269

END OF DISCHARGE BATTERY PARAMETERS
BATTERY CUTOFF VOLTAGE 4.60 REC. CELL CUTOFF VOLTAGE 1.85
CAPACITY OF BATTERY FOR THIS DISCHARGE 91.17 PERCENT
TOTAL BATTERY VOLTAGE 5.974
INDIVIDUAL CELL VOLTAGES SPECIFIC GRAVITY
CELL# 1 1.999 1.240
CELL# 5 1.984 1.238
CELL# 4 1.985 1.238

DISCHARGE NUMBER 30
DISCHARGE CURRENT 3.40 DURATION OF DISCHARGE 5.37 HR.
RECORDED CELL # 1
START OF DISCHARGE BATTERY PARAMETERS
TOTAL BATTERY VOLTAGE 6.638
INDIVIDUAL CELL VOLTAGES SPECIFIC GRAVITY
CELL# 1 2.221 1.272
CELL# 5 2.207 1.269
CELL# 4 2.206 1.271

END OF DISCHARGE BATTERY PARAMETERS
BATTERY CUTOFF VOLTAGE 4.60 REC. CELL CUTOFF VOLTAGE 1.84
CAPACITY OF BATTERY FOR THIS DISCHARGE 92.60 PERCENT
TOTAL BATTERY VOLTAGE 6.409
INDIVIDUAL CELL VOLTAGES SPECIFIC GRAVITY
CELL# 1 2.138 1.225
CELL# 5 2.135 1.225
CELL# 4 2.136 1.220

DISCHARGE NUMBER 32
DISCHARGE CURRENT 1.30 DURATION OF DISCHARGE 0.0 HR.
RECORDED CELL # 1
START OF DISCHARGE BATTERY PARAMETERS
TOTAL BATTERY VOLTAGE 6.467
INDIVIDUAL CELL VOLTAGES SPECIFIC GRAVITY
CELL# 1 2.162 1.267
CELL# 5 2.147 1.264
CELL# 4 2.155 1.266

THE RECORDED CELL CONTROLLED THE DISCHARGE
END OF DISCHARGE BATTERY PARAMETERS
BATTERY CUTOFF VOLTAGE 0.0 REC. CELL CUTOFF VOLTAGE 0.0
CAPACITY OF BATTERY FOR THIS DISCHARGE 0.0 PERCENT
TOTAL BATTERY VOLTAGE 6.120
INDIVIDUAL CELL VOLTAGES SPECIFIC GRAVITY
CELL# 1 2.053 1.227
CELL# 5 2.031 1.228
CELL# 4 2.036 1.233

DISCHARGE NUMBER 33

DISCHARGE CURRENT 2.20 DURATION OF DISCHARGE 10.12 HR.
RECORDED CELL # 5
START OF DISCHARGE BATTERY PARAMETERS
TOTAL BATTERY VOLTAGE 6.625
INDIVIDUAL CELL VOLTAGES SPECIFIC GRAVITY
CELL# 1 2.213 1.271
CELL# 5 2.201 1.266
CELL# 4 2.211 1.267

THE RECORDED CELL CONTROLLED THE DISCHARGE
END OF DISCHARGE BATTERY PARAMETERS
BATTERY CUTOFF VOLTAGE 4.70 REC. CELL CUTOFF VOLTAGE 1.40
CAPACITY OF BATTERY FOR THIS DISCHARGE 104.57 PERCENT
TOTAL BATTERY VOLTAGE 6.191
INDIVIDUAL CELL VOLTAGES SPECIFIC GRAVITY
CELL# 1 2.066 1.216
CELL# 5 2.061 1.213
CELL# 4 2.058 1.218

DISCHARGE NUMBER 34
DISCHARGE CURRENT 2.80 DURATION OF DISCHARGE 7.08 HR.
RECORDED CELL # 1
START OF DISCHARGE BATTERY PARAMETERS
TOTAL BATTERY VOLTAGE 6.523
INDIVIDUAL CELL VOLTAGES SPECIFIC GRAVITY
CELL# 1 2.163 1.265
CELL# 5 2.177 1.263
CELL# 4 2.188 1.265

END OF DISCHARGE BATTERY PARAMETERS
BATTERY CUTOFF VOLTAGE 5.10 REC. CELL CUTOFF VOLTAGE 1.80
CAPACITY OF BATTERY FOR THIS DISCHARGE 97.25 PERCENT
TOTAL BATTERY VOLTAGE 6.224
INDIVIDUAL CELL VOLTAGES SPECIFIC GRAVITY
CELL# 1 2.074 1.225
CELL# 5 2.067 1.215
CELL# 4 2.082 1.205

DISCHARGE NUMBER 35
DISCHARGE CURRENT 3.45 DURATION OF DISCHARGE 5.77 HR.
RECORDED CELL # 1
START OF DISCHARGE BATTERY PARAMETERS
TOTAL BATTERY VOLTAGE 6.737
INDIVIDUAL CELL VOLTAGES SPECIFIC GRAVITY
CELL# 1 2.178 1.269
CELL# 5 2.227 1.267
CELL# 4 2.332 1.264

END OF DISCHARGE BATTERY PARAMETERS
BATTERY CUTOFF VOLTAGE 4.49 REC. CELL CUTOFF VOLTAGE 1.60
CAPACITY OF BATTERY FOR THIS DISCHARGE 101.23 PERCENT
TOTAL BATTERY VOLTAGE 5.935
INDIVIDUAL CELL VOLTAGES SPECIFIC GRAVITY
CELL# 1 1.976 1.222
CELL# 5 1.963 1.213
CELL# 4 1.959 1.208

DISCHARGE NUMBER 36
DISCHARGE CURRENT 4.50 DURATION OF DISCHARGE 3.95 HR.
RECORDED CELL # 1
START OF DISCHARGE BATTERY PARAMETERS
TOTAL BATTERY VOLTAGE 6.650
INDIVIDUAL CELL VOLTAGES SPECIFIC GRAVITY
CELL# 1 2.219 1.269
CELL# 5 2.216 1.268
CELL# 4 2.215 1.265

END OF DISCHARGE BATTERY PARAMETERS
BATTERY CUTOFF VOLTAGE 4.69 REC. CELL CUTOFF VOLTAGE 1.81
CAPACITY OF BATTERY FOR THIS DISCHARGE 94.82 PERCENT
TOTAL BATTERY VOLTAGE 5.949
INDIVIDUAL CELL VOLTAGES SPECIFIC GRAVITY
CELL# 1 2.017 1.236
CELL# 5 1.995 1.235
CELL# 4 1.947 1.220

DISCHARGE NUMBER 37
DISCHARGE CURRENT 3.40 DURATION OF DISCHARGE 5.43 HR.
RECORDED CELL # 1
START OF DISCHARGE BATTERY PARAMETERS
TOTAL BATTERY VOLTAGE 6.521
INDIVIDUAL CELL VOLTAGES SPECIFIC GRAVITY
CELL# 1 2.176 1.269
CELL# 5 2.172 1.268
CELL# 4 2.170 1.267

END OF DISCHARGE BATTERY PARAMETERS
BATTERY CUTOFF VOLTAGE 4.40 REC. CELL CUTOFF VOLTAGE 1.67
CAPACITY OF BATTERY FOR THIS DISCHARGE 93.76 PERCENT
TOTAL BATTERY VOLTAGE 6.247
INDIVIDUAL CELL VOLTAGES SPECIFIC GRAVITY
CELL# 1 2.084 1.221
CELL# 5 2.079 1.215
CELL# 4 2.076 1.213

DISCHARGE NUMBER 38
DISCHARGE CURRENT 2.80 DURATION OF DISCHARGE 0.0 HR.
RECORDED CELL # 1
START OF DISCHARGE BATTERY PARAMETERS
TOTAL BATTERY VOLTAGE 6.499
INDIVIDUAL CELL VOLTAGES SPECIFIC GRAVITY
CELL# 1 2.167 1.269
CELL# 5 2.164 1.269
CELL# 4 2.163 1.269

THE RECORDED CELL CONTROLLED THE DISCHARGE
END OF DISCHARGE BATTERY PARAMETERS
BATTERY CUTOFF VOLTAGE 0.0 REC. CELL CUTOFF VOLTAGE 0.0
CAPACITY OF BATTERY FOR THIS DISCHARGE 0.0 PERCENT
TOTAL BATTERY VOLTAGE 6.357
INDIVIDUAL CELL VOLTAGES SPECIFIC GRAVITY
CELL# 1 2.122 1.225
CELL# 5 2.177 1.217
CELL# 4 2.118 1.217

DISCHARGE NUMBER 39
DISCHARGE CURRENT 3.40 DURATION OF DISCHARGE 5.33 HR.
RECORDED CELL # 1
START OF DISCHARGE BATTERY PARAMETERS
TOTAL BATTERY VOLTAGE 6.796
INDIVIDUAL CELL VOLTAGES SPECIFIC GRAVITY
CELL# 1 2.280 1.271
CELL# 5 2.267 1.269
CELL# 4 2.265 1.268

THE RECORDED CELL CONTROLLED THE DISCHARGE
END OF DISCHARGE BATTERY PARAMETERS
BATTERY CUTOFF VOLTAGE 4.45 REC. CELL CUTOFF VOLTAGE 1.00
CAPACITY OF BATTERY FOR THIS DISCHARGE 92.03 PERCENT
TOTAL BATTERY VOLTAGE 6.178
INDIVIDUAL CELL VOLTAGES SPECIFIC GRAVITY

CELL# 1 2.060 1.225
CELL# 5 2.063 1.224
CELL# 4 2.063 1.223

DISCHARGE NUMBER 40
DISCHARGE CURRENT 3.40 DURATION OF DISCHARGE 5.48 HR.
RECORDED CELL # 1
START OF DISCHARGE BATTERY PARAMETERS
TOTAL BATTERY VOLTAGE 6.708
INDIVIDUAL CELL VOLTAGES SPECIFIC GRAVITY
CELL# 1 2.243 1.267
CELL# 5 2.233 1.262
CELL# 4 2.237 1.265

THE RECORDED CELL CONTROLLED THE DISCHARGE
END OF DISCHARGE BATTERY PARAMETERS
BATTERY CUTOFF VOLTAGE 4.50 REC. CELL CUTOFF VOLTAGE 0.80
CAPACITY OF BATTERY FOR THIS DISCHARGE 94.62 PERCENT
TOTAL BATTERY VOLTAGE 5.900
INDIVIDUAL CELL VOLTAGES SPECIFIC GRAVITY
CELL# 1 1.930 1.223
CELL# 5 1.978 1.226
CELL# 4 1.962 1.223

DISCHARGE NUMBER 41
DISCHARGE CURRENT 3.40 DURATION OF DISCHARGE 4.73 HR.
RECORDED CELL # 1
START OF DISCHARGE BATTERY PARAMETERS
TOTAL BATTERY VOLTAGE 6.715
INDIVIDUAL CELL VOLTAGES SPECIFIC GRAVITY
CELL# 1 2.238 1.270
CELL# 5 2.241 1.270
CELL# 4 2.236 1.270

THE RECORDED CELL CONTROLLED THE DISCHARGE
END OF DISCHARGE BATTERY PARAMETERS
BATTERY CUTOFF VOLTAGE 4.40 REC. CELL CUTOFF VOLTAGE 0.68
CAPACITY OF BATTERY FOR THIS DISCHARGE 81.68 PERCENT
TOTAL BATTERY VOLTAGE 6.069
INDIVIDUAL CELL VOLTAGES SPECIFIC GRAVITY
CELL# 1 2.033 1.235
CELL# 5 2.039 1.230
CELL# 4 1.997 1.236

DISCHARGE NUMBER 42
DISCHARGE CURRENT 3.40 DURATION OF DISCHARGE 5.20 HR.
RECORDED CELL # 1
START OF DISCHARGE BATTERY PARAMETERS
TOTAL BATTERY VOLTAGE 6.991
INDIVIDUAL CELL VOLTAGES SPECIFIC GRAVITY
CELL# 1 2.325 1.273
CELL# 5 2.334 1.271
CELL# 4 2.332 1.269

THE RECORDED CELL CONTROLLED THE DISCHARGE
END OF DISCHARGE BATTERY PARAMETERS
BATTERY CUTOFF VOLTAGE 4.50 REC. CELL CUTOFF VOLTAGE 0.96
CAPACITY OF BATTERY FOR THIS DISCHARGE 89.74 PERCENT
TOTAL BATTERY VOLTAGE 5.914
INDIVIDUAL CELL VOLTAGES SPECIFIC GRAVITY
CELL# 1 1.945 1.222
CELL# 5 1.991 1.228
CELL# 4 1.978 1.238

DISCHARGE NUMBER 43

DISCHARGE CURRENT 3.45 DURATION OF DISCHARGE 0.0 HR.
 RECORDED CELL # 1
 START OF DISCHARGE BATTERY PARAMETERS
 TOTAL BATTERY VOLTAGE 6.680
 INDIVIDUAL CELL VOLTAGES SPECIFIC GRAVITY
 CELL# 1 2.179 1.256
 CELL# 5 2.249 1.265
 CELL# 4 2.252 1.261

THE RECORDED CELL CONTROLLED THE DISCHARGE
 END OF DISCHARGE BATTERY PARAMETERS
 BATTERY CUTOFF VOLTAGE 0.0 REC. CELL CUTOFF VOLTAGE 0.0
 CAPACITY OF BATTERY FOR THIS DISCHARGE 0.0 PERCENT
 TOTAL BATTERY VOLTAGE 6.248
 INDIVIDUAL CELL VOLTAGES SPECIFIC GRAVITY
 CELL# 1 2.083 1.212
 CELL# 5 2.085 1.214
 CELL# 4 2.080 1.210

DISCHARGE NUMBER 44
 DISCHARGE CURRENT 3.40 DURATION OF DISCHARGE 5.00 HR.
 RECORDED CELL # 1
 START OF DISCHARGE BATTERY PARAMETERS
 TOTAL BATTERY VOLTAGE 6.740
 INDIVIDUAL CELL VOLTAGES SPECIFIC GRAVITY
 CELL# 1 2.210 1.268
 CELL# 5 2.264 1.266
 CELL# 4 2.264 1.264

THE RECORDED CELL CONTROLLED THE DISCHARGE
 END OF DISCHARGE BATTERY PARAMETERS
 BATTERY CUTOFF VOLTAGE 4.78 REC. CELL CUTOFF VOLTAGE 1.05
 CAPACITY OF BATTERY FOR THIS DISCHARGE 86.28 PERCENT
 TOTAL BATTERY VOLTAGE 6.002
 INDIVIDUAL CELL VOLTAGES SPECIFIC GRAVITY
 CELL# 1 1.980 1.220
 CELL# 5 2.014 1.221
 CELL# 4 2.003 1.220

DISCHARGE NUMBER 45
 DISCHARGE CURRENT 3.40 DURATION OF DISCHARGE 4.50 HR.
 RECORDED CELL # 1
 START OF DISCHARGE BATTERY PARAMETERS
 TOTAL BATTERY VOLTAGE 6.667
 INDIVIDUAL CELL VOLTAGES SPECIFIC GRAVITY
 CELL# 1 2.150 1.262
 CELL# 5 2.262 1.265
 CELL# 4 2.259 1.260

THE RECORDED CELL CONTROLLED THE DISCHARGE
 END OF DISCHARGE BATTERY PARAMETERS
 BATTERY CUTOFF VOLTAGE 4.82 REC. CELL CUTOFF VOLTAGE 1.05
 CAPACITY OF BATTERY FOR THIS DISCHARGE 77.66 PERCENT
 TOTAL BATTERY VOLTAGE 2.970
 INDIVIDUAL CELL VOLTAGES SPECIFIC GRAVITY
 CELL# 1 1.985 1.219
 CELL# 5 2.025 1.220
 CELL# 4 2.016 1.220

APPENDIX C

CYCLE HISTORY OF PBSB # 2

DISCHARGE NUMBER 1
 DISCHARGE CURRENT 3.40 DURATION OF DISCHARGE 4.87 HR.
 RECORDED CELL # 1
 START OF DISCHARGE BATTERY PARAMETERS
 TOTAL BATTERY VOLTAGE 6.382
 INDIVIDUAL CELL VOLTAGES SPECIFIC GRAVITY
 CELL# 1 2.115 1.261
 CELL# 2 2.131 1.263
 CELL# 3 2.135 1.261

THE RECORDED CELL CONTROLLED THE DISCHARGE
 END OF DISCHARGE BATTERY PARAMETERS
 BATTERY CUTOFF VOLTAGE 5.22 REC. CELL CUTOFF VOLTAGE 1.55
 CAPACITY OF BATTERY FOR THIS DISCHARGE 90.38 PERCENT
 TOTAL BATTERY VOLTAGE 6.213
 INDIVIDUAL CELL VOLTAGES SPECIFIC GRAVITY
 CELL# 1 2.070 1.215
 CELL# 2 2.072 1.220
 CELL# 3 2.071 1.220

DISCHARGE NUMBER 2
 DISCHARGE CURRENT 4.50 DURATION OF DISCHARGE 3.40 HR.
 RECORDED CELL # 1
 START OF DISCHARGE BATTERY PARAMETERS
 TOTAL BATTERY VOLTAGE 6.384
 INDIVIDUAL CELL VOLTAGES SPECIFIC GRAVITY
 CELL# 1 2.132 1.262
 CELL# 2 2.126 1.260
 CELL# 3 2.127 1.261

THE RECORDED CELL CONTROLLED THE DISCHARGE
 END OF DISCHARGE BATTERY PARAMETERS
 BATTERY CUTOFF VOLTAGE 5.05 REC. CELL CUTOFF VOLTAGE 1.45
 CAPACITY OF BATTERY FOR THIS DISCHARGE 87.94 PERCENT
 TOTAL BATTERY VOLTAGE 6.176
 INDIVIDUAL CELL VOLTAGES SPECIFIC GRAVITY
 CELL# 1 2.063 1.220
 CELL# 2 2.059 1.215
 CELL# 3 2.062 1.215

END OF CHARGE BATTERY ON OPEN CIRCUIT
 CHARGE NUMBER 2
 TOTAL BATTERY VOLTAGE 6.681
 INDIVIDUAL CELL VOLTAGES SPECIFIC GRAVITY
 CELL# 1 2.213 1.260
 CELL# 2 2.235 1.256
 CELL# 3 2.236 1.265

DISCHARGE NUMBER 3
 DISCHARGE CURRENT 2.60 DURATION OF DISCHARGE 7.87 HR.
 RECORDED CELL # 2
 START OF DISCHARGE BATTERY PARAMETERS
 TOTAL BATTERY VOLTAGE 6.383
 INDIVIDUAL CELL VOLTAGES SPECIFIC GRAVITY
 CELL# 1 2.129 1.262
 CELL# 2 2.124 1.260
 CELL# 3 2.130 1.265

END OF DISCHARGE BATTERY PARAMETERS
BATTERY CUTOFF VOLTAGE 5.00 REC. CELL CUTOFF VOLTAGE 1.85
CAPACITY OF BATTERY FOR THIS DISCHARGE 106.39 PERCENT
TOTAL BATTERY VOLTAGE 6.200
INDIVIDUAL CELL VOLTAGES SPECIFIC GRAVITY
CELL# 1 2.064 1.208
CELL# 2 2.067 1.205
CELL# 3 2.070 1.220

DISCHARGE NUMBER 4
DISCHARGE CURRENT 2.80 DURATION OF DISCHARGE 6.77 HR.
RECORDED CELL # 1
START OF DISCHARGE BATTERY PARAMETERS
TOTAL BATTERY VOLTAGE 6.393
INDIVIDUAL CELL VOLTAGES SPECIFIC GRAVITY
CELL# 1 2.110 1.261
CELL# 2 2.110 1.260
CELL# 3 2.110 1.255

THE RECORDED CELL CONTROLLED THE DISCHARGE
END OF DISCHARGE BATTERY PARAMETERS
BATTERY CUTOFF VOLTAGE 5.38 REC. CELL CUTOFF VOLTAGE 1.55
CAPACITY OF BATTERY FOR THIS DISCHARGE 99.90 PERCENT
TOTAL BATTERY VOLTAGE 6.230
INDIVIDUAL CELL VOLTAGES SPECIFIC GRAVITY
CELL# 1 2.067 1.203
CELL# 2 2.068 1.205
CELL# 3 2.063 1.206

END OF CHARGE BATTERY ON OPEN CIRCUIT
CHARGE NUMBER 4
TOTAL BATTERY VOLTAGE 6.691
INDIVIDUAL CELL VOLTAGES SPECIFIC GRAVITY
CELL# 1 2.214 1.264
CELL# 2 2.235 1.262
CELL# 3 2.226 1.258

DISCHARGE NUMBER 5
DISCHARGE CURRENT 2.11 DURATION OF DISCHARGE 10.22 HR.
RECORDED CELL # 3
START OF DISCHARGE BATTERY PARAMETERS
TOTAL BATTERY VOLTAGE 6.309
INDIVIDUAL CELL VOLTAGES SPECIFIC GRAVITY
CELL# 1 2.108 1.263
CELL# 2 2.101 1.265
CELL# 3 2.095 1.261

END OF DISCHARGE BATTERY PARAMETERS
BATTERY CUTOFF VOLTAGE 4.59 REC. CELL CUTOFF VOLTAGE 1.86
CAPACITY OF BATTERY FOR THIS DISCHARGE 107.94 PERCENT
TOTAL BATTERY VOLTAGE 6.044
INDIVIDUAL CELL VOLTAGES SPECIFIC GRAVITY
CELL# 1 2.006 1.195
CELL# 2 2.026 1.203
CELL# 3 2.015 1.217

DISCHARGE NUMBER 6
DISCHARGE CURRENT 2.47 DURATION OF DISCHARGE 8.42 HR.
RECORDED CELL # 2
START OF DISCHARGE BATTERY PARAMETERS
TOTAL BATTERY VOLTAGE 6.455
INDIVIDUAL CELL VOLTAGES SPECIFIC GRAVITY
CELL# 1 2.152 1.257
CELL# 2 2.156 1.250
CELL# 3 2.148 1.255

END OF DISCHARGE BATTERY PARAMETERS
BATTERY CUTOFF VOLTAGE 4.95 REC. CELL CUTOFF VOLTAGE 1.87
CAPACITY OF BATTERY FOR THIS DISCHARGE 107.12 PERCENT
TOTAL BATTERY VOLTAGE 6.082
INDIVIDUAL CELL VOLTAGES SPECIFIC GRAVITY
CELL# 1 2.025 1.205
CELL# 2 2.033 1.205
CELL# 3 2.026 1.205

DISCHARGE NUMBER 7
DISCHARGE CURRENT 3.20 DURATION OF DISCHARGE 6.48 HR.
RECORDED CELL # 1
START OF DISCHARGE BATTERY PARAMETERS
TOTAL BATTERY VOLTAGE 6.851
INDIVIDUAL CELL VOLTAGES SPECIFIC GRAVITY
CELL# 1 2.282 1.265
CELL# 2 2.291 1.266
CELL# 3 2.287 1.256

THE RECORDED CELL CONTROLLED THE DISCHARGE
END OF DISCHARGE BATTERY PARAMETERS
BATTERY CUTOFF VOLTAGE 4.78 REC. CELL CUTOFF VOLTAGE 1.10
CAPACITY OF BATTERY FOR THIS DISCHARGE 112.07 PERCENT
TOTAL BATTERY VOLTAGE 5.850
INDIVIDUAL CELL VOLTAGES SPECIFIC GRAVITY
CELL# 1 1.93 1.204
CELL# 2 1.93 1.209
CELL# 3 1.93 1.205

END OF CHARGE BATTERY ON OPEN CIRCUIT
CHARGE NUMBER 7
TOTAL BATTERY VOLTAGE 6.848
INDIVIDUAL CELL VOLTAGES SPECIFIC GRAVITY
CELL# 1 2.276 1.265
CELL# 2 2.284 1.265
CELL# 3 2.280 1.256

DISCHARGE NUMBER 8
DISCHARGE CURRENT 2.11 DURATION OF DISCHARGE 10.65 HR.
RECORDED CELL # 2
START OF DISCHARGE BATTERY PARAMETERS
TOTAL BATTERY VOLTAGE 6.340
INDIVIDUAL CELL VOLTAGES SPECIFIC GRAVITY
CELL# 1 2.115 1.266
CELL# 2 2.110 1.266
CELL# 3 2.113 1.256

END OF DISCHARGE BATTERY PARAMETERS
BATTERY CUTOFF VOLTAGE 4.52 REC. CELL CUTOFF VOLTAGE 1.89
CAPACITY OF BATTERY FOR THIS DISCHARGE 112.53 PERCENT
TOTAL BATTERY VOLTAGE 6.066
INDIVIDUAL CELL VOLTAGES SPECIFIC GRAVITY
CELL# 1 2.016 1.205
CELL# 2 2.032 1.205
CELL# 3 2.018 1.202

END OF CHARGE BATTERY ON FINISHING RATE
CHARGE NUMBER 8
TOTAL BATTERY VOLTAGE 8.081
INDIVIDUAL CELL VOLTAGES SPECIFIC GRAVITY
CELL# 1 2.681 1.260
CELL# 2 2.708 1.260
CELL# 3 2.690 1.253

DISCHARGE NUMBER 9
DISCHARGE CURRENT 3.02 DURATION OF DISCHARGE 6.88 HR.
RECORDED CELL # 3
START OF DISCHARGE BATTERY PARAMETERS
TOTAL BATTERY VOLTAGE 6.776
INDIVIDUAL CELL VOLTAGES SPECIFIC GRAVITY
CELL# 1 2.257 1.260
CELL# 2 2.273 1.260
CELL# 3 2.267 1.253

END OF DISCHARGE BATTERY PARAMETERS
BATTERY CUTOFF VOLTAGE 4.59 REC. CELL CUTOFF VOLTAGE 1.89
CAPACITY OF BATTERY FOR THIS DISCHARGE 111.11 PERCENT
TOTAL BATTERY VOLTAGE 5.841
INDIVIDUAL CELL VOLTAGES SPECIFIC GRAVITY
CELL# 1 1.899 1.203
CELL# 2 1.967 1.205
CELL# 3 1.963 1.210

END OF CHARGE BATTERY ON FINISHING RATE
CHARGE NUMBER 9
TOTAL BATTERY VOLTAGE 8.070
INDIVIDUAL CELL VOLTAGES SPECIFIC GRAVITY
CELL# 1 2.676 1.250
CELL# 2 2.707 1.248
CELL# 3 2.687 1.244
DISCHARGE NUMBER 10
DISCHARGE CURRENT 3.10 DURATION OF DISCHARGE 6.47 HR.
RECORDED CELL # 1
START OF DISCHARGE BATTERY PARAMETERS
TOTAL BATTERY VOLTAGE 6.725
INDIVIDUAL CELL VOLTAGES SPECIFIC GRAVITY
CELL# 1 2.233 1.260
CELL# 2 2.249 1.264
CELL# 3 2.243 1.258

THE RECORDED CELL CONTROLLED THE DISCHARGE
END OF DISCHARGE BATTERY PARAMETERS
BATTERY CUTOFF VOLTAGE 4.60 REC. CELL CUTOFF VOLTAGE 1.08
CAPACITY OF BATTERY FOR THIS DISCHARGE 107.66 PERCENT
TOTAL BATTERY VOLTAGE 6.178
INDIVIDUAL CELL VOLTAGES SPECIFIC GRAVITY
CELL# 1 2.059 1.202
CELL# 2 2.063 1.200
CELL# 3 2.056 1.201

END OF CHARGE BATTERY ON FINISHING RATE
CHARGE NUMBER 10
TOTAL BATTERY VOLTAGE 8.057
INDIVIDUAL CELL VOLTAGES SPECIFIC GRAVITY
CELL# 1 2.684 1.267
CELL# 2 2.693 1.267
CELL# 3 2.680 1.262

DISCHARGE NUMBER 11
DISCHARGE CURRENT 3.10 DURATION OF DISCHARGE 6.35 HR.
RECORDED CELL # 4
START OF DISCHARGE BATTERY PARAMETERS
TOTAL BATTERY VOLTAGE 6.665
INDIVIDUAL CELL VOLTAGES SPECIFIC GRAVITY
CELL# 1 2.240 1.267
CELL# 2 2.240 1.267
CELL# 4 2.180 1.257

THE RECORDED CELL CONTROLLED THE DISCHARGE
END OF DISCHARGE BATTERY PARAMETERS

BATTERY CUTOFF VOLTAGE 4.68 REC. CELL CUTOFF VOLTAGE 1.10
CAPACITY OF BATTERY FOR THIS DISCHARGE 105.72 PERCENT
TOTAL BATTERY VOLTAGE 6.170
INDIVIDUAL CELL VOLTAGES SPECIFIC GRAVITY
CELL# 1 2.063 1.210
CELL# 2 2.059 1.210
CELL# 4 2.045 1.205

END OF CHARGE BATTERY ON FINISHING RATE
CHARGE NUMBER 11
TOTAL BATTERY VOLTAGE 8.073
INDIVIDUAL CELL VOLTAGES SPECIFIC GRAVITY
CELL# 1 2.689 1.266
CELL# 2 2.706 1.263
CELL# 4 2.677 1.261

DISCHARGE NUMBER 12
DISCHARGE CURRENT 3.10 DURATION OF DISCHARGE 6.43 HR.
RECORDED CELL # 1
START OF DISCHARGE BATTERY PARAMETERS
TOTAL BATTERY VOLTAGE 6.403
INDIVIDUAL CELL VOLTAGES SPECIFIC GRAVITY
CELL# 1 2.150 1.261
CELL# 2 2.146 1.262
CELL# 4 2.129 1.263

END OF DISCHARGE BATTERY PARAMETERS
BATTERY CUTOFF VOLTAGE 4.57 REC. CELL CUTOFF VOLTAGE 1.70
CAPACITY OF BATTERY FOR THIS DISCHARGE 107.11 PERCENT
TOTAL BATTERY VOLTAGE 5.954
INDIVIDUAL CELL VOLTAGES SPECIFIC GRAVITY
CELL# 1 1.988 1.203
CELL# 2 2.002 1.210
CELL# 4 1.958 1.210

END OF CHARGE BATTERY ON FINISHING RATE
CHARGE NUMBER 12
TOTAL BATTERY VOLTAGE 8.052
INDIVIDUAL CELL VOLTAGES SPECIFIC GRAVITY
CELL# 1 2.686 1.264
CELL# 2 2.707 1.264
CELL# 4 2.659 1.262

DISCHARGE NUMBER 13
DISCHARGE CURRENT 3.10 DURATION OF DISCHARGE 6.25 HR.
RECORDED CELL # 2
START OF DISCHARGE BATTERY PARAMETERS
TOTAL BATTERY VOLTAGE 6.727
INDIVIDUAL CELL VOLTAGES SPECIFIC GRAVITY
CELL# 1 2.281 1.264
CELL# 2 2.295 1.264
CELL# 4 2.225 1.262

END OF DISCHARGE BATTERY PARAMETERS
BATTERY CUTOFF VOLTAGE 4.65 REC. CELL CUTOFF VOLTAGE 1.82
CAPACITY OF BATTERY FOR THIS DISCHARGE 104.06 PERCENT
TOTAL BATTERY VOLTAGE 6.185
INDIVIDUAL CELL VOLTAGES SPECIFIC GRAVITY
CELL# 1 2.006 1.205
CELL# 2 2.067 1.203
CELL# 4 2.053 1.210

END OF CHARGE BATTERY ON FINISHING RATE
CHARGE NUMBER 13
TOTAL BATTERY VOLTAGE 8.053

INDIVIDUAL CELL VOLTAGES SPECIFIC GRAVITY
CELL# 1 2.685 1.268
CELL# 2 2.703 1.264
CELL# 4 2.665 1.256

DISCHARGE NUMBER 14
DISCHARGE CURRENT 2.20 DURATION OF DISCHARGE 9.73 HR.
RECORDED CELL # 4
START OF DISCHARGE BATTERY PARAMETERS
TOTAL BATTERY VOLTAGE 6.450
INDIVIDUAL CELL VOLTAGES SPECIFIC GRAVITY
CELL# 1 2.162 1.266
CELL# 2 2.160 1.266
CELL# 4 2.130 1.262

END OF DISCHARGE BATTERY PARAMETERS
BATTERY CUTOFF VOLTAGE 4.80 REC. CELL CUTOFF VOLTAGE 1.73
CAPACITY OF BATTERY FOR THIS DISCHARGE 108.04 PERCENT
TOTAL BATTERY VOLTAGE 6.170
INDIVIDUAL CELL VOLTAGES SPECIFIC GRAVITY
CELL# 1 2.050 1.200
CELL# 2 2.050 1.220
CELL# 4 2.040 1.220

END OF CHARGE BATTERY ON FINISHING RATE
CHARGE NUMBER 14
TOTAL BATTERY VOLTAGE 8.021
INDIVIDUAL CELL VOLTAGES SPECIFIC GRAVITY
CELL# 1 2.674 1.266
CELL# 2 2.698 1.265
CELL# 4 2.649 1.262

DISCHARGE NUMBER 15
DISCHARGE CURRENT 2.50 DURATION OF DISCHARGE 8.33 HR.
RECORDED CELL # 1
START OF DISCHARGE BATTERY PARAMETERS
TOTAL BATTERY VOLTAGE 6.862
INDIVIDUAL CELL VOLTAGES SPECIFIC GRAVITY
CELL# 1 2.295 1.266
CELL# 2 2.309 1.265
CELL# 4 2.258 1.262

THE RECORDED CELL CONTROLLED THE DISCHARGE
END OF DISCHARGE BATTERY PARAMETERS
BATTERY CUTOFF VOLTAGE 5.00 REC. CELL CUTOFF VOLTAGE 1.35
CAPACITY OF BATTERY FOR THIS DISCHARGE 107.59 PERCENT
TOTAL BATTERY VOLTAGE 6.170
INDIVIDUAL CELL VOLTAGES SPECIFIC GRAVITY
CELL# 1 2.057 1.200
CELL# 2 2.063 1.203
CELL# 4 2.050 1.200

END OF CHARGE BATTERY ON FINISHING RATE
CHARGE NUMBER 15
TOTAL BATTERY VOLTAGE 7.985
INDIVIDUAL CELL VOLTAGES SPECIFIC GRAVITY
CELL# 1 2.655 1.264
CELL# 2 2.688 1.270
CELL# 4 2.640 1.263

DISCHARGE NUMBER 16
DISCHARGE CURRENT 4.10 DURATION OF DISCHARGE 4.62 HR.
RECORDED CELL # 2
START OF DISCHARGE BATTERY PARAMETERS
TOTAL BATTERY VOLTAGE 6.775

INDIVIDUAL CELL VOLTAGES SPECIFIC GRAVITY
CELL# 1 2.269 1.264
CELL# 2 2.292 1.270
CELL# 4 2.238 1.263

END OF DISCHARGE BATTERY PARAMETERS
BATTERY CUTOFF VOLTAGE 5.03 REC. CELL CUTOFF VOLTAGE 1.90
CAPACITY OF BATTERY FOR THIS DISCHARGE 106.95 PERCENT
TOTAL BATTERY VOLTAGE 5.867
INDIVIDUAL CELL VOLTAGES SPECIFIC GRAVITY
CELL# 1 1.945 1.210
CELL# 2 1.979 1.219
CELL# 4 1.936 1.221

END OF CHARGE BATTERY ON FINISHING RATE
CHARGE NUMBER 16
TOTAL BATTERY VOLTAGE 8.071
INDIVIDUAL CELL VOLTAGES SPECIFIC GRAVITY
CELL# 1 2.686 1.269
CELL# 2 2.715 1.275
CELL# 4 2.670 1.270

DISCHARGE NUMBER 17
DISCHARGE CURRENT 3.10 DURATION OF DISCHARGE 6.27 HR.
RECORDED CELL # 4
START OF DISCHARGE BATTERY PARAMETERS
TOTAL BATTERY VOLTAGE 6.891
INDIVIDUAL CELL VOLTAGES SPECIFIC GRAVITY
CELL# 1 2.279 1.269
CELL# 2 2.335 1.275
CELL# 4 2.277 1.270

END OF DISCHARGE BATTERY PARAMETERS
BATTERY CUTOFF VOLTAGE 4.08 REC. CELL CUTOFF VOLTAGE 1.79
CAPACITY OF BATTERY FOR THIS DISCHARGE 104.33 PERCENT
TOTAL BATTERY VOLTAGE 6.089
INDIVIDUAL CELL VOLTAGES SPECIFIC GRAVITY
CELL# 1 2.028 1.219
CELL# 2 2.041 1.220
CELL# 4 2.020 1.215

END OF CHARGE BATTERY ON FINISHING RATE
CHARGE NUMBER 17
TOTAL BATTERY VOLTAGE 8.029
INDIVIDUAL CELL VOLTAGES SPECIFIC GRAVITY
CELL# 1 2.669 1.263
CELL# 2 2.696 1.264
CELL# 4 2.654 1.270

DISCHARGE NUMBER 18
DISCHARGE CURRENT 3.10 DURATION OF DISCHARGE 6.08 HR.
RECORDED CELL # 1
START OF DISCHARGE BATTERY PARAMETERS
TOTAL BATTERY VOLTAGE 6.778
INDIVIDUAL CELL VOLTAGES SPECIFIC GRAVITY
CELL# 1 2.285 1.263
CELL# 2 2.306 1.264
CELL# 4 2.624 1.270

THE RECORDED CELL CONTROLLED THE DISCHARGE
END OF DISCHARGE BATTERY PARAMETERS
BATTERY CUTOFF VOLTAGE 4.70 REC. CELL CUTOFF VOLTAGE 1.11
CAPACITY OF BATTERY FOR THIS DISCHARGE 101.28 PERCENT
TOTAL BATTERY VOLTAGE 6.099
INDIVIDUAL CELL VOLTAGES SPECIFIC GRAVITY

CELL# 1 2.066 1.223
CELL# 2 2.071 1.220
CELL# 4 2.062 1.221

END OF CHARGE BATTERY ON FINISHING RATE
CHARGE NUMBER 18
TOTAL BATTERY VOLTAGE 8.007
INDIVIDUAL CELL VOLTAGES SPECIFIC GRAVITY
CELL# 1 2.662 1.270
CELL# 2 2.692 1.277
CELL# 4 2.652 1.267

DISCHARGE NUMBER 19
DISCHARGE CURRENT 4.10 DURATION OF DISCHARGE 4.32 HR.
RECORDED CELL # 2
START OF DISCHARGE BATTERY PARAMETERS
TOTAL BATTERY VOLTAGE 6.738
INDIVIDUAL CELL VOLTAGES SPECIFIC GRAVITY
CELL# 1 2.265 1.270
CELL# 2 2.287 1.277
CELL# 4 2.248 1.267

END OF DISCHARGE BATTERY PARAMETERS
BATTERY CUTOFF VOLTAGE 5.11 REC. CELL CUTOFF VOLTAGE 1.90
CAPACITY OF BATTERY FOR THIS DISCHARGE 100.00 PERCENT
TOTAL BATTERY VOLTAGE 5.898
INDIVIDUAL CELL VOLTAGES SPECIFIC GRAVITY
CELL# 1 1.917 1.232
CELL# 2 1.980 1.230
CELL# 4 1.952 1.225

END OF CHARGE BATTERY ON FINISHING RATE
CHARGE NUMBER 19
TOTAL BATTERY VOLTAGE 8.042
INDIVIDUAL CELL VOLTAGES SPECIFIC GRAVITY
CELL# 1 2.670 1.280
CELL# 2 2.699 1.284
CELL# 4 2.659 1.281

DISCHARGE NUMBER 20
DISCHARGE CURRENT 3.20 DURATION OF DISCHARGE 5.77 HR.
RECORDED CELL # 4
START OF DISCHARGE BATTERY PARAMETERS
TOTAL BATTERY VOLTAGE 6.681
INDIVIDUAL CELL VOLTAGES SPECIFIC GRAVITY
CELL# 1 2.226 1.280
CELL# 2 2.243 1.284
CELL# 4 2.214 1.281

END OF DISCHARGE BATTERY PARAMETERS
BATTERY CUTOFF VOLTAGE 4.70 REC. CELL CUTOFF VOLTAGE 1.87
CAPACITY OF BATTERY FOR THIS DISCHARGE 99.67 PERCENT
TOTAL BATTERY VOLTAGE 6.045
INDIVIDUAL CELL VOLTAGES SPECIFIC GRAVITY
CELL# 1 2.006 1.223
CELL# 2 2.030 1.226
CELL# 4 2.009 1.224

END OF CHARGE BATTERY ON FINISHING RATE
CHARGE NUMBER 20
TOTAL BATTERY VOLTAGE 8.174
INDIVIDUAL CELL VOLTAGES SPECIFIC GRAVITY
CELL# 1 2.724 1.275
CELL# 2 2.742 1.274
CELL# 4 2.708 1.270

DISCHARGE NUMBER 21
DISCHARGE CURRENT 3.40 DURATION OF DISCHARGE 5.17 HR.
RECORDED CELL # 5
START OF DISCHARGE BATTERY PARAMETERS
TOTAL BATTERY VOLTAGE 6.434
INDIVIDUAL CELL VOLTAGES SPECIFIC GRAVITY
CELL# 1 2.168 1.275
CELL# 5 2.113 1.267
CELL# 4 2.152 1.270

THE RECORDED CELL CONTROLLED THE DISCHARGE
END OF DISCHARGE BATTERY PARAMETERS
BATTERY CUTOFF VOLTAGE 5.20 REC. CELL CUTOFF VOLTAGE 1.40
CAPACITY OF BATTERY FOR THIS DISCHARGE 95.93 PERCENT
TOTAL BATTERY VOLTAGE 6.218
INDIVIDUAL CELL VOLTAGES SPECIFIC GRAVITY
CELL# 1 2.082 1.235
CELL# 5 2.060 1.226
CELL# 4 2.076 1.229

DISCHARGE NUMBER 22
DISCHARGE CURRENT 3.50 DURATION OF DISCHARGE 5.10 HR.
RECORDED CELL # 1
START OF DISCHARGE BATTERY PARAMETERS
TOTAL BATTERY VOLTAGE 6.572
INDIVIDUAL CELL VOLTAGES SPECIFIC GRAVITY
CELL# 1 2.218 1.271
CELL# 5 2.160 1.268
CELL# 4 2.204 1.272

END OF DISCHARGE BATTERY PARAMETERS
BATTERY CUTOFF VOLTAGE 5.10 REC. CELL CUTOFF VOLTAGE 1.85
CAPACITY OF BATTERY FOR THIS DISCHARGE 98.01 PERCENT
TOTAL BATTERY VOLTAGE 6.117
INDIVIDUAL CELL VOLTAGES SPECIFIC GRAVITY
CELL# 1 2.034 1.235
CELL# 5 1.999 1.228
CELL# 4 2.030 1.230

END OF CHARGE BATTERY ON FINISHING RATE
CHARGE NUMBER 22
TOTAL BATTERY VOLTAGE 8.020
INDIVIDUAL CELL VOLTAGES SPECIFIC GRAVITY
CELL# 1 2.680 1.267
CELL# 5 2.630 1.262
CELL# 4 2.680 1.272

DISCHARGE NUMBER 23
DISCHARGE CURRENT 3.20 DURATION OF DISCHARGE 5.97 HR.
RECORDED CELL # 4
START OF DISCHARGE BATTERY PARAMETERS
TOTAL BATTERY VOLTAGE 6.482
INDIVIDUAL CELL VOLTAGES SPECIFIC GRAVITY
CELL# 1 2.169 1.267
CELL# 5 2.173 1.262
CELL# 4 2.181 1.272

END OF DISCHARGE BATTERY PARAMETERS
BATTERY CUTOFF VOLTAGE 4.70 REC. CELL CUTOFF VOLTAGE 1.88
CAPACITY OF BATTERY FOR THIS DISCHARGE 103.13 PERCENT
TOTAL BATTERY VOLTAGE 6.211
INDIVIDUAL CELL VOLTAGES SPECIFIC GRAVITY
CELL# 1 2.075 1.238
CELL# 5 2.064 1.224

CELL# 4 2.070

1.227

END OF CHARGE BATTERY ON FINISHING RATE

CHARGE NUMBER 23

TOTAL BATTERY VOLTAGE 7.960

INDIVIDUAL CELL VOLTAGES SPECIFIC GRAVITY

CELL# 1 2.668

1.280

CELL# 5 2.632

1.262

CELL# 4 2.659

1.272

DISCHARGE NUMBER 24

DISCHARGE CURRENT 3.20

DURATION OF DISCHARGE 5.83 HR.

RECORDED CELL # 1

START OF DISCHARGE BATTERY PARAMETERS

TOTAL BATTERY VOLTAGE 6.509

INDIVIDUAL CELL VOLTAGES SPECIFIC GRAVITY

CELL# 1 2.187

1.280

CELL# 5 2.152

1.262

CELL# 4 2.172

1.272

END OF DISCHARGE BATTERY PARAMETERS

BATTERY CUTOFF VOLTAGE 4.55

REC. CELL CUTOFF VOLTAGE 1.83

CAPACITY OF BATTERY FOR THIS DISCHARGE 100.83 PERCENT

TOTAL BATTERY VOLTAGE 6.204

INDIVIDUAL CELL VOLTAGES SPECIFIC GRAVITY

CELL# 1 2.069

1.239

CELL# 5 2.069

1.237

CELL# 4 2.066

1.231

END OF CHARGE BATTERY ON FINISHING RATE

CHARGE NUMBER 24

TOTAL BATTERY VOLTAGE 8.069

INDIVIDUAL CELL VOLTAGES SPECIFIC GRAVITY

CELL# 1 2.705

1.270

CELL# 5 2.664

1.270

CELL# 4 2.699

1.278

DISCHARGE NUMBER 25

DISCHARGE CURRENT 3.20

DURATION OF DISCHARGE 5.83 HR.

RECORDED CELL # 5

START OF DISCHARGE BATTERY PARAMETERS

TOTAL BATTERY VOLTAGE 6.735

INDIVIDUAL CELL VOLTAGES SPECIFIC GRAVITY

CELL# 1 2.262

1.270

CELL# 5 2.216

1.270

CELL# 4 2.260

1.278

END OF DISCHARGE BATTERY PARAMETERS

BATTERY CUTOFF VOLTAGE 4.70

REC. CELL CUTOFF VOLTAGE 1.90

CAPACITY OF BATTERY FOR THIS DISCHARGE 100.83 PERCENT

TOTAL BATTERY VOLTAGE 6.137

INDIVIDUAL CELL VOLTAGES SPECIFIC GRAVITY

CELL# 1 2.047

1.236

CELL# 5 2.041

1.234

CELL# 4 2.049

1.224

END OF CHARGE BATTERY ON FINISHING RATE

CHARGE NUMBER 25

TOTAL BATTERY VOLTAGE 7.961

INDIVIDUAL CELL VOLTAGES SPECIFIC GRAVITY

CELL# 1 2.665

1.289

CELL# 5 2.634

1.290

CELL# 4 2.662

1.281

DISCHARGE NUMBER 26
DISCHARGE CURRENT 3.20 DURATION OF DISCHARGE 5.75 HR.
RECORDED CELL # 1
START OF DISCHARGE BATTERY PARAMETERS
TOTAL BATTERY VOLTAGE 6.785
INDIVIDUAL CELL VOLTAGES SPECIFIC GRAVITY
CELL# 1 2.241 1.284
CELL# 5 2.209 1.290
CELL# 4 2.235 1.290

END OF DISCHARGE BATTERY PARAMETERS
BATTERY CUTOFF VOLTAGE 4.58 REC. CELL CUTOFF VOLTAGE 1.81
CAPACITY OF BATTERY FOR THIS DISCHARGE 99.40 PERCENT
TOTAL BATTERY VOLTAGE 6.208
INDIVIDUAL CELL VOLTAGES SPECIFIC GRAVITY
CELL# 1 2.069 1.235
CELL# 5 2.071 1.239
CELL# 4 2.067 1.229

END OF CHARGE BATTERY ON FINISHING RATE
CHARGE NUMBER 26
TOTAL BATTERY VOLTAGE 8.046
INDIVIDUAL CELL VOLTAGES SPECIFIC GRAVITY
CELL# 1 2.688 1.290
CELL# 5 2.653 1.270
CELL# 4 2.685 1.275

DISCHARGE NUMBER 27
DISCHARGE CURRENT 1.50 DURATION OF DISCHARGE 14.17 HR.
RECORDED CELL # 4
START OF DISCHARGE BATTERY PARAMETERS
TOTAL BATTERY VOLTAGE 6.911
INDIVIDUAL CELL VOLTAGES SPECIFIC GRAVITY
CELL# 1 2.318 1.290
CELL# 5 2.280 1.270
CELL# 4 2.313 1.275

END OF DISCHARGE BATTERY PARAMETERS
BATTERY CUTOFF VOLTAGE 4.43 REC. CELL CUTOFF VOLTAGE 1.87
CAPACITY OF BATTERY FOR THIS DISCHARGE 100.00 PERCENT
TOTAL BATTERY VOLTAGE 6.187
INDIVIDUAL CELL VOLTAGES SPECIFIC GRAVITY
CELL# 1 2.062 1.225
CELL# 5 2.064 1.230
CELL# 4 2.059 1.225

END OF CHARGE BATTERY ON FINISHING RATE
CHARGE NUMBER 27
TOTAL BATTERY VOLTAGE 8.038
INDIVIDUAL CELL VOLTAGES SPECIFIC GRAVITY
CELL# 1 2.693 1.271
CELL# 5 2.656 1.271
CELL# 4 2.689 1.271

DISCHARGE NUMBER 28
DISCHARGE CURRENT 3.20 DURATION OF DISCHARGE 6.37 HR.
RECORDED CELL # 1
START OF DISCHARGE BATTERY PARAMETERS
TOTAL BATTERY VOLTAGE 6.653
INDIVIDUAL CELL VOLTAGES SPECIFIC GRAVITY
CELL# 1 2.237 1.271
CELL# 5 2.200 1.276
CELL# 4 2.233 1.270

END OF DISCHARGE BATTERY PARAMETERS

BATTERY CUTOFF VOLTAGE 4.60 REC. CELL CUTOFF VOLTAGE 1.75
CAPACITY OF BATTERY FOR THIS DISCHARGE 110.04 PERCENT
TOTAL BATTERY VOLTAGE 6.041
INDIVIDUAL CELL VOLTAGES SPECIFIC GRAVITY
CELL# 1 2.009 1.238
CELL# 5 2.003 1.236
CELL# 4 2.019 1.225

END OF CHARGE BATTERY ON FINISHING RATE
CHARGE NUMBER 28
TOTAL BATTERY VOLTAGE 7.993
INDIVIDUAL CELL VOLTAGES SPECIFIC GRAVITY
CELL# 1 2.671 1.268
CELL# 5 2.646 1.272
CELL# 4 2.673 1.278

DISCHARGE NUMBER 29
DISCHARGE CURRENT 3.20 DURATION OF DISCHARGE 6.20 HR.
RECORDED CELL # 5
START OF DISCHARGE BATTERY PARAMETERS
TOTAL BATTERY VOLTAGE 6.662
INDIVIDUAL CELL VOLTAGES SPECIFIC GRAVITY
CELL# 1 2.231 1.268
CELL# 5 2.207 1.272
CELL# 4 2.228 1.278

THE RECORDED CELL CONTROLLED THE DISCHARGE
END OF DISCHARGE BATTERY PARAMETERS
BATTERY CUTOFF VOLTAGE 4.60 REC. CELL CUTOFF VOLTAGE 1.00
CAPACITY OF BATTERY FOR THIS DISCHARGE 107.17 PERCENT
TOTAL BATTERY VOLTAGE 6.207
INDIVIDUAL CELL VOLTAGES SPECIFIC GRAVITY
CELL# 1 2.069 1.231
CELL# 5 2.070 1.231
CELL# 4 2.066 1.222

END OF CHARGE BATTERY ON FINISHING RATE
CHARGE NUMBER 29
TOTAL BATTERY VOLTAGE 7.939
INDIVIDUAL CELL VOLTAGES SPECIFIC GRAVITY
CELL# 1 2.656 1.280
CELL# 5 2.625 1.286
CELL# 4 2.658 1.291

DISCHARGE NUMBER 30
DISCHARGE CURRENT 3.20 DURATION OF DISCHARGE 6.12 HR.
RECORDED CELL # 1
START OF DISCHARGE BATTERY PARAMETERS
TOTAL BATTERY VOLTAGE 6.621
INDIVIDUAL CELL VOLTAGES SPECIFIC GRAVITY
CELL# 1 2.215 1.280
CELL# 5 2.200 1.286
CELL# 4 2.214 1.291

END OF DISCHARGE BATTERY PARAMETERS
BATTERY CUTOFF VOLTAGE 4.48 REC. CELL CUTOFF VOLTAGE 1.72
CAPACITY OF BATTERY FOR THIS DISCHARGE 105.72 PERCENT
TOTAL BATTERY VOLTAGE 6.027
INDIVIDUAL CELL VOLTAGES SPECIFIC GRAVITY
CELL# 1 2.008 1.233
CELL# 5 2.001 1.235
CELL# 4 2.024 1.227

END OF CHARGE BATTERY ON FINISHING RATE
CHARGE NUMBER 30

TOTAL BATTERY VOLTAGE 8.137
INDIVIDUAL CELL VOLTAGES SPECIFIC GRAVITY
CELL# 1 2.722 1.262
CELL# 5 2.694 1.274
CELL# 4 2.721 1.264

DISCHARGE NUMBER 31
DISCHARGE CURRENT 3.20 DURATION OF DISCHARGE 6.42 HR.
RECORDED CELL # 5
START OF DISCHARGE BATTERY PARAMETERS
TOTAL BATTERY VOLTAGE 6.860
INDIVIDUAL CELL VOLTAGES SPECIFIC GRAVITY
CELL# 1 2.303 1.262
CELL# 5 2.276 1.274
CELL# 4 2.298 1.262

THE RECORDED CELL CONTROLLED THE DISCHARGE
END OF DISCHARGE BATTERY PARAMETERS
BATTERY CUTOFF VOLTAGE 4.51 REC. CELL CUTOFF VOLTAGE 1.10
CAPACITY OF BATTERY FOR THIS DISCHARGE 110.91 PERCENT
TOTAL BATTERY VOLTAGE 5.936
INDIVIDUAL CELL VOLTAGES SPECIFIC GRAVITY
CELL# 1 1.974 1.233
CELL# 5 1.967 1.235
CELL# 4 1.995 1.230

END OF CHARGE BATTERY ON FINISHING RATE
CHARGE NUMBER 31
TOTAL BATTERY VOLTAGE 2.883
INDIVIDUAL CELL VOLTAGES SPECIFIC GRAVITY
CELL# 1 2.639 1.279
CELL# 5 2.615 1.280
CELL# 4 2.629 1.286

DISCHARGE NUMBER 32
DISCHARGE CURRENT 3.20 DURATION OF DISCHARGE 5.93 HR.
RECORDED CELL # 1
START OF DISCHARGE BATTERY PARAMETERS
TOTAL BATTERY VOLTAGE 6.706
INDIVIDUAL CELL VOLTAGES SPECIFIC GRAVITY
CELL# 1 2.247 1.279
CELL# 5 2.237 1.280
CELL# 4 2.233 1.286

THE RECORDED CELL CONTROLLED THE DISCHARGE
END OF DISCHARGE BATTERY PARAMETERS
BATTERY CUTOFF VOLTAGE 4.66 REC. CELL CUTOFF VOLTAGE 1.25
CAPACITY OF BATTERY FOR THIS DISCHARGE 102.56 PERCENT
TOTAL BATTERY VOLTAGE 6.201
INDIVIDUAL CELL VOLTAGES SPECIFIC GRAVITY
CELL# 1 2.064 1.235
CELL# 5 2.071 1.237
CELL# 4 2.065 1.227

END OF CHARGE BATTERY ON FINISHING RATE
CHARGE NUMBER 32
TOTAL BATTERY VOLTAGE 7.973
INDIVIDUAL CELL VOLTAGES SPECIFIC GRAVITY
CELL# 1 2.664 1.266
CELL# 5 2.644 1.276
CELL# 4 2.665 1.273

DISCHARGE NUMBER 33
DISCHARGE CURRENT 3.20 DURATION OF DISCHARGE 5.90 HR.
RECORDED CELL # 4

START OF DISCHARGE BATTERY PARAMETERS

TOTAL BATTERY VOLTAGE 6.493
INDIVIDUAL CELL VOLTAGES SPECIFIC GRAVITY
CELL# 1 2.169 1.278
CELL# 5 2.165 1.282
CELL# 4 2.158 1.278

END OF DISCHARGE BATTERY PARAMETERS

BATTERY CUTOFF VOLTAGE 4.50 REC. CELL CUTOFF VOLTAGE 1.84
CAPACITY OF BATTERY FOR THIS DISCHARGE 101.99 PERCENT
TOTAL BATTERY VOLTAGE 6.201
INDIVIDUAL CELL VOLTAGES SPECIFIC GRAVITY
CELL# 1 2.063 1.232
CELL# 5 2.079 1.237
CELL# 4 2.063 1.225

END OF CHARGE BATTERY ON FINISHING RATE

CHARGE NUMBER 33
TOTAL BATTERY VOLTAGE 8.150
INDIVIDUAL CELL VOLTAGES SPECIFIC GRAVITY
CELL# 1 2.710 1.259
CELL# 5 2.680 1.260
CELL# 4 2.710 1.256

DISCHARGE NUMBER 34

DISCHARGE CURRENT 3.20 DURATION OF DISCHARGE 6.32 HR.
RECORDED CELL # 1
START OF DISCHARGE BATTERY PARAMETERS
TOTAL BATTERY VOLTAGE 6.452
INDIVIDUAL CELL VOLTAGES SPECIFIC GRAVITY
CELL# 1 2.155 1.262
CELL# 5 2.162 1.274
CELL# 4 2.135 1.234

END OF DISCHARGE BATTERY PARAMETERS

BATTERY CUTOFF VOLTAGE 4.60 REC. CELL CUTOFF VOLTAGE 1.70
CAPACITY OF BATTERY FOR THIS DISCHARGE 109.18 PERCENT
TOTAL BATTERY VOLTAGE 6.085
INDIVIDUAL CELL VOLTAGES SPECIFIC GRAVITY
CELL# 1 2.029 1.228
CELL# 5 2.028 1.235
CELL# 4 2.035 1.225

END OF CHARGE BATTERY ON FINISHING RATE

CHARGE NUMBER 34
TOTAL BATTERY VOLTAGE 8.130
INDIVIDUAL CELL VOLTAGES SPECIFIC GRAVITY
CELL# 1 2.722 1.262
CELL# 5 2.690 1.269
CELL# 4 2.718 1.264

DISCHARGE NUMBER 35

DISCHARGE CURRENT 3.20 DURATION OF DISCHARGE 6.25 HR.
RECORDED CELL # 5
START OF DISCHARGE BATTERY PARAMETERS
TOTAL BATTERY VOLTAGE 6.774
INDIVIDUAL CELL VOLTAGES SPECIFIC GRAVITY
CELL# 1 2.270 1.262
CELL# 5 2.245 1.269
CELL# 4 2.278 1.264

END OF DISCHARGE BATTERY PARAMETERS

BATTERY CUTOFF VOLTAGE 4.53 REC. CELL CUTOFF VOLTAGE 1.55
CAPACITY OF BATTERY FOR THIS DISCHARGE 108.04 PERCENT
TOTAL BATTERY VOLTAGE 6.112

INDIVIDUAL CELL VOLTAGES SPECIFIC GRAVITY
CELL# 1 2.032 1.235
CELL# 5 2.042 1.238
CELL# 4 2.045 1.224

END OF CHARGE BATTERY ON FINISHING RATE
CHARGE NUMBER 35
TOTAL BATTERY VOLTAGE 8.070
INDIVIDUAL CELL VOLTAGES SPECIFIC GRAVITY
CELL# 1 2.687 1.275
CELL# 5 2.662 1.274
CELL# 4 2.700 1.268

DISCHARGE NUMBER 36
DISCHARGE CURRENT 3.20 DURATION OF DISCHARGE 6.13 HR.
RECORDED CELL # 1
START OF DISCHARGE BATTERY PARAMETERS
TOTAL BATTERY VOLTAGE 6.457
INDIVIDUAL CELL VOLTAGES SPECIFIC GRAVITY
CELL# 1 2.157 1.270
CELL# 5 2.164 1.275
CELL# 4 2.139 1.266

END OF DISCHARGE BATTERY PARAMETERS
BATTERY CUTOFF VOLTAGE 4.60 REC. CELL CUTOFF VOLTAGE 1.55
CAPACITY OF BATTERY FOR THIS DISCHARGE 106.02 PERCENT
TOTAL BATTERY VOLTAGE 6.120
INDIVIDUAL CELL VOLTAGES SPECIFIC GRAVITY
CELL# 1 2.039 1.233
CELL# 5 2.040 1.245
CELL# 4 2.053 1.228

END OF CHARGE BATTERY ON FINISHING RATE
CHARGE NUMBER 36
TOTAL BATTERY VOLTAGE 8.014
INDIVIDUAL CELL VOLTAGES SPECIFIC GRAVITY
CELL# 1 2.678 1.282
CELL# 5 2.646 1.280
CELL# 4 2.681 1.269

DISCHARGE NUMBER 37
DISCHARGE CURRENT 3.20 DURATION OF DISCHARGE 6.22 HR.
RECORDED CELL # 1
START OF DISCHARGE BATTERY PARAMETERS
TOTAL BATTERY VOLTAGE 6.431
INDIVIDUAL CELL VOLTAGES SPECIFIC GRAVITY
CELL# 1 2.147 1.268
CELL# 5 2.152 1.277
CELL# 4 2.135 1.265

THE RECORDED CELL CONTROLLED THE DISCHARGE
END OF DISCHARGE BATTERY PARAMETERS
BATTERY CUTOFF VOLTAGE 4.60 REC. CELL CUTOFF VOLTAGE 1.40
CAPACITY OF BATTERY FOR THIS DISCHARGE 107.45 PERCENT
TOTAL BATTERY VOLTAGE 6.069
INDIVIDUAL CELL VOLTAGES SPECIFIC GRAVITY
CELL# 1 2.017 1.231
CELL# 5 2.025 1.237
CELL# 4 2.039 1.225

END OF CHARGE BATTERY ON FINISHING RATE
CHARGE NUMBER 37
TOTAL BATTERY VOLTAGE 8.066
INDIVIDUAL CELL VOLTAGES SPECIFIC GRAVITY
CELL# 1 2.698 1.262

CELL# 5 2.664 1.275
CELL# 4 2.702 1.262

DISCHARGE NUMBER 38
DISCHARGE CURRENT 3.20 DURATION OF DISCHARGE 6.43 HR.
RECORDED CELL # 5
START OF DISCHARGE BATTERY PARAMETERS
TOTAL BATTERY VOLTAGE 6.413
INDIVIDUAL CELL VOLTAGES SPECIFIC GRAVITY
CELL# 1 2.142 1.266
CELL# 5 2.147 1.275
CELL# 4 2.124 1.265

THE RECORDED CELL CONTROLLED THE DISCHARGE
END OF DISCHARGE BATTERY PARAMETERS
BATTERY CUTOFF VOLTAGE 4.67 REC. CELL CUTOFF VOLTAGE 1.35
CAPACITY OF BATTERY FOR THIS DISCHARGE 111.20 PERCENT
TOTAL BATTERY VOLTAGE 6.203
INDIVIDUAL CELL VOLTAGES SPECIFIC GRAVITY
CELL# 1 2.063 1.234
CELL# 5 2.079 1.239
CELL# 4 2.066 1.225

END OF CHARGE BATTERY ON FINISHING RATE
CHARGE NUMBER 38
TOTAL BATTERY VOLTAGE 8.076
INDIVIDUAL CELL VOLTAGES SPECIFIC GRAVITY
CELL# 1 2.698 1.266
CELL# 5 2.665 1.275
CELL# 4 2.704 1.270

DISCHARGE NUMBER 39
DISCHARGE CURRENT 3.20 DURATION OF DISCHARGE 6.25 HR.
RECORDED CELL # 1
START OF DISCHARGE BATTERY PARAMETERS
TOTAL BATTERY VOLTAGE 6.451
INDIVIDUAL CELL VOLTAGES SPECIFIC GRAVITY
CELL# 1 2.153 1.266
CELL# 5 2.162 1.275
CELL# 4 2.139 1.268

THE RECORDED CELL CONTROLLED THE DISCHARGE
END OF DISCHARGE BATTERY PARAMETERS
BATTERY CUTOFF VOLTAGE 4.76 REC. CELL CUTOFF VOLTAGE 1.21
CAPACITY OF BATTERY FOR THIS DISCHARGE 108.04 PERCENT
TOTAL BATTERY VOLTAGE 6.183
INDIVIDUAL CELL VOLTAGES SPECIFIC GRAVITY
CELL# 1 2.054 1.235
CELL# 5 2.070 1.241
CELL# 4 2.064 1.229

END OF CHARGE BATTERY ON FINISHING RATE
CHARGE NUMBER 39
TOTAL BATTERY VOLTAGE 8.079
INDIVIDUAL CELL VOLTAGES SPECIFIC GRAVITY
CELL# 1 2.693 1.268
CELL# 5 2.666 1.274
CELL# 4 2.709 1.268

DISCHARGE NUMBER 40
DISCHARGE CURRENT 3.20 DURATION OF DISCHARGE 6.20 HR.
RECORDED CELL # 1
START OF DISCHARGE BATTERY PARAMETERS
TOTAL BATTERY VOLTAGE 6.426
INDIVIDUAL CELL VOLTAGES SPECIFIC GRAVITY

CELL# 1 2.145 1.286
CELL# 5 2.151 1.290
CELL# 4 2.128 1.276

THE RECORDED CELL CONTROLLED THE DISCHARGE
END OF DISCHARGE BATTERY PARAMETERS
BATTERY CUTOFF VOLTAGE 4.78 REC. CELL CUTOFF VOLTAGE 1.29
CAPACITY OF BATTERY FOR THIS DISCHARGE 107.17 PERCENT
TOTAL BATTERY VOLTAGE 6.197
INDIVIDUAL CELL VOLTAGES SPECIFIC GRAVITY
CELL# 1 2.061 1.233
CELL# 5 2.070 1.240
CELL# 4 2.066 1.230

END OF CHARGE BATTERY ON FINISHING RATE
CHARGE NUMBER 40
TOTAL BATTERY VOLTAGE 8.080
INDIVIDUAL CELL VOLTAGES SPECIFIC GRAVITY
CELL# 1 2.699 1.278
CELL# 5 2.674 1.276
CELL# 4 2.707 1.270

DISCHARGE NUMBER 41
DISCHARGE CURRENT 3.20 DURATION OF DISCHARGE 6.12 HR.
RECORDED CELL # 1
START OF DISCHARGE BATTERY PARAMETERS
TOTAL BATTERY VOLTAGE 6.653
INDIVIDUAL CELL VOLTAGES SPECIFIC GRAVITY
CELL# 1 2.216 1.278
CELL# 5 2.216 1.276
CELL# 4 2.232 1.270

THE RECORDED CELL CONTROLLED THE DISCHARGE
END OF DISCHARGE BATTERY PARAMETERS
BATTERY CUTOFF VOLTAGE 4.70 REC. CELL CUTOFF VOLTAGE 1.20
CAPACITY OF BATTERY FOR THIS DISCHARGE 105.72 PERCENT
TOTAL BATTERY VOLTAGE 5.874
INDIVIDUAL CELL VOLTAGES SPECIFIC GRAVITY
CELL# 1 1.890 1.240
CELL# 5 1.930 1.245
CELL# 4 1.990 1.232

END OF CHARGE BATTERY ON FINISHING RATE
CHARGE NUMBER 41
TOTAL BATTERY VOLTAGE 8.066
INDIVIDUAL CELL VOLTAGES SPECIFIC GRAVITY
CELL# 1 2.654 1.265
CELL# 5 2.690 1.275
CELL# 4 2.724 1.266

DISCHARGE NUMBER 42
DISCHARGE CURRENT 3.20 DURATION OF DISCHARGE 6.08 HR.
RECORDED CELL # 4
START OF DISCHARGE BATTERY PARAMETERS
TOTAL BATTERY VOLTAGE 6.931
INDIVIDUAL CELL VOLTAGES SPECIFIC GRAVITY
CELL# 1 2.392 1.265
CELL# 5 2.250 1.275
CELL# 4 2.292 1.266

END OF DISCHARGE BATTERY PARAMETERS
BATTERY CUTOFF VOLTAGE 4.67 REC. CELL CUTOFF VOLTAGE 1.80
CAPACITY OF BATTERY FOR THIS DISCHARGE 105.15 PERCENT
TOTAL BATTERY VOLTAGE 5.909
INDIVIDUAL CELL VOLTAGES SPECIFIC GRAVITY

CELL# 1 1.935 1.246
CELL# 5 1.963 1.248
CELL# 4 1.999 1.235

END OF CHARGE BATTERY ON FINISHING RATE
CHARGE NUMBER 42
TOTAL BATTERY VOLTAGE 7.999
INDIVIDUAL CELL VOLTAGES SPECIFIC GRAVITY
CELL# 1 2.639 1.260
CELL# 5 2.666 1.265
CELL# 4 2.694 1.263

DISCHARGE NUMBER 43
DISCHARGE CURRENT 3.20 DURATION OF DISCHARGE 5.97 HR.
RECORDED CELL # 1
START OF DISCHARGE BATTERY PARAMETERS
TOTAL BATTERY VOLTAGE 6.933
INDIVIDUAL CELL VOLTAGES SPECIFIC GRAVITY
CELL# 1 2.405 1.260
CELL# 5 2.267 1.265
CELL# 4 2.284 1.263

THE RECORDED CELL CONTROLLED THE DISCHARGE
END OF DISCHARGE BATTERY PARAMETERS
BATTERY CUTOFF VOLTAGE 4.75 REC. CELL CUTOFF VOLTAGE 1.16
CAPACITY OF BATTERY FOR THIS DISCHARGE 101.40 PERCENT
TOTAL BATTERY VOLTAGE 6.216
INDIVIDUAL CELL VOLTAGES SPECIFIC GRAVITY
CELL# 1 2.067 1.240
CELL# 5 2.078 1.244
CELL# 4 2.071 1.234

END OF CHARGE BATTERY ON FINISHING RATE
CHARGE NUMBER 43
TOTAL BATTERY VOLTAGE 7.967
INDIVIDUAL CELL VOLTAGES SPECIFIC GRAVITY
CELL# 1 2.637 1.272
CELL# 5 2.654 1.280
CELL# 4 2.675 1.274

DISCHARGE NUMBER 44
DISCHARGE CURRENT 3.20 DURATION OF DISCHARGE 5.85 HR.
RECORDED CELL # 5
START OF DISCHARGE BATTERY PARAMETERS
TOTAL BATTERY VOLTAGE 6.900
INDIVIDUAL CELL VOLTAGES SPECIFIC GRAVITY
CELL# 1 2.385 1.272
CELL# 5 2.257 1.280
CELL# 4 2.255 1.274

END OF DISCHARGE BATTERY PARAMETERS
BATTERY CUTOFF VOLTAGE 4.60 REC. CELL CUTOFF VOLTAGE 1.83
CAPACITY OF BATTERY FOR THIS DISCHARGE 101.12 PERCENT
TOTAL BATTERY VOLTAGE 5.993
INDIVIDUAL CELL VOLTAGES SPECIFIC GRAVITY
CELL# 1 1.974 1.242
CELL# 5 1.999 1.247
CELL# 4 2.014 1.235

END OF CHARGE BATTERY ON FINISHING RATE
CHARGE NUMBER 44
TOTAL BATTERY VOLTAGE 8.016
INDIVIDUAL CELL VOLTAGES SPECIFIC GRAVITY
CELL# 1 2.648 1.264
CELL# 5 2.675 1.280

CELL# 4 2.694

1.270

DISCHARGE NUMBER 45
DISCHARGE CURRENT 3.20 DURATION OF DISCHARGE 5.68 HR.
RECORDED CELL # 1
START OF DISCHARGE BATTERY PARAMETERS
TOTAL BATTERY VOLTAGE 6.952
INDIVIDUAL CELL VOLTAGES SPECIFIC GRAVITY
CELL# 1 2.406 1.264
CELL# 5 2.269 1.280
CELL# 4 2.277 1.270

THE RECORDED CELL CONTROLLED THE DISCHARGE
END OF DISCHARGE BATTERY PARAMETERS
BATTERY CUTOFF VOLTAGE 4.60 REC. CELL CUTOFF VOLTAGE 1.05
CAPACITY OF BATTERY FOR THIS DISCHARGE 98.24 PERCENT
TOTAL BATTERY VOLTAGE 6.074
INDIVIDUAL CELL VOLTAGES SPECIFIC GRAVITY
CELL# 1 2.009 1.241
CELL# 5 2.028 1.250
CELL# 4 2.037 1.235

END OF CHARGE BATTERY ON FINISHING RATE
CHARGE NUMBER 45
TOTAL BATTERY VOLTAGE 8.073
INDIVIDUAL CELL VOLTAGES SPECIFIC GRAVITY
CELL# 1 2.676 1.272
CELL# 5 2.690 1.277
CELL# 4 2.258 1.271

DISCHARGE NUMBER 46
DISCHARGE CURRENT 3.20 DURATION OF DISCHARGE 5.95 HR.
RECORDED CELL # 4
START OF DISCHARGE BATTERY PARAMETERS
TOTAL BATTERY VOLTAGE 6.878
INDIVIDUAL CELL VOLTAGES SPECIFIC GRAVITY
CELL# 1 2.379 1.272
CELL# 5 2.240 1.277
CELL# 4 2.258 1.271

END OF DISCHARGE BATTERY PARAMETERS
BATTERY CUTOFF VOLTAGE 4.78 REC. CELL CUTOFF VOLTAGE 1.70
CAPACITY OF BATTERY FOR THIS DISCHARGE 102.85 PERCENT
TOTAL BATTERY VOLTAGE 6.232
INDIVIDUAL CELL VOLTAGES SPECIFIC GRAVITY
CELL# 1 2.073 1.240
CELL# 5 2.085 1.241
CELL# 4 2.072 1.235

END OF CHARGE BATTERY ON FINISHING RATE
CHARGE NUMBER 46
TOTAL BATTERY VOLTAGE 8.078
INDIVIDUAL CELL VOLTAGES SPECIFIC GRAVITY
CELL# 1 2.676 1.269
CELL# 5 2.696 1.272
CELL# 4 2.706 1.266

DISCHARGE NUMBER 47
DISCHARGE CURRENT 3.20 DURATION OF DISCHARGE 5.92 HR.
RECORDED CELL # 1
START OF DISCHARGE BATTERY PARAMETERS
TOTAL BATTERY VOLTAGE 7.070
INDIVIDUAL CELL VOLTAGES SPECIFIC GRAVITY
CELL# 1 2.448 1.269
CELL# 5 2.312 1.272

CELL# 4 2.310

1.266

THE RECORDED CELL CONTROLLED THE DISCHARGE
END OF DISCHARGE BATTERY PARAMETERS
BATTERY CUTOFF VOLTAGE 4.58 REC. CELL CUTOFF VOLTAGE 1.25
CAPACITY OF BATTERY FOR THIS DISCHARGE 102.26 PERCENT
TOTAL BATTERY VOLTAGE 6.159
INDIVIDUAL CELL VOLTAGES SPECIFIC GRAVITY
CELL# 1 2.048 1.241
CELL# 5 2.061 1.239
CELL# 4 2.055 1.232

END OF CHARGE BATTERY ON FINISHING RATE
CHARGE NUMBER 47
TOTAL BATTERY VOLTAGE 8.085
INDIVIDUAL CELL VOLTAGES SPECIFIC GRAVITY
CELL# 1 2.665 1.272
CELL# 5 2.706 1.276
CELL# 4 2.713 1.276

DISCHARGE NUMBER 48
DISCHARGE CURRENT 3.20 DURATION OF DISCHARGE 5.70 HR.
RECORDED CELL # 1
START OF DISCHARGE BATTERY PARAMETERS
TOTAL BATTERY VOLTAGE 6.710
INDIVIDUAL CELL VOLTAGES SPECIFIC GRAVITY
CELL# 1 2.257 1.272
CELL# 5 2.250 1.276
CELL# 4 2.242 1.276

THE RECORDED CELL CONTROLLED THE DISCHARGE
END OF DISCHARGE BATTERY PARAMETERS
BATTERY CUTOFF VOLTAGE 4.80 REC. CELL CUTOFF VOLTAGE 1.30
CAPACITY OF BATTERY FOR THIS DISCHARGE 98.53 PERCENT
TOTAL BATTERY VOLTAGE 6.189
INDIVIDUAL CELL VOLTAGES SPECIFIC GRAVITY
CELL# 1 2.057 1.244
CELL# 5 2.070 1.246
CELL# 4 2.062 1.236

END OF CHARGE BATTERY ON FINISHING RATE
CHARGE NUMBER 48
TOTAL BATTERY VOLTAGE 8.053
INDIVIDUAL CELL VOLTAGES SPECIFIC GRAVITY
CELL# 1 2.651 1.269
CELL# 5 2.689 1.280
CELL# 4 2.713 1.277

DISCHARGE NUMBER 49
DISCHARGE CURRENT 3.20 DURATION OF DISCHARGE 5.63 HR.
RECORDED CELL # 1
START OF DISCHARGE BATTERY PARAMETERS
TOTAL BATTERY VOLTAGE 7.120
INDIVIDUAL CELL VOLTAGES SPECIFIC GRAVITY
CELL# 1 2.468 1.269
CELL# 5 2.689 1.280
CELL# 4 2.337 1.277

THE RECORDED CELL CONTROLLED THE DISCHARGE
END OF DISCHARGE BATTERY PARAMETERS
BATTERY CUTOFF VOLTAGE 4.72 REC. CELL CUTOFF VOLTAGE 1.20
CAPACITY OF BATTERY FOR THIS DISCHARGE 97.37 PERCENT
TOTAL BATTERY VOLTAGE 6.104
INDIVIDUAL CELL VOLTAGES SPECIFIC GRAVITY
CELL# 1 2.023 1.244

CELL# 5 2.041 1.252
CELL# 4 2.040 1.241

END OF CHARGE BATTERY ON FINISHING RATE
CHARGE NUMBER 49
TOTAL BATTERY VOLTAGE 8.057
INDIVIDUAL CELL VOLTAGES SPECIFIC GRAVITY
CELL# 1 2.645 1.269
CELL# 5 2.695 1.272
CELL# 4 2.715 1.270

DISCHARGE NUMBER 50
DISCHARGE CURRENT 3.20 DURATION OF DISCHARGE 5.45 HR.
RECORDED CELL # 4
START OF DISCHARGE BATTERY PARAMETERS
TOTAL BATTERY VOLTAGE 7.076
INDIVIDUAL CELL VOLTAGES SPECIFIC GRAVITY
CELL# 1 2.452 1.269
CELL# 5 2.317 1.272
CELL# 4 2.324 1.270

END OF DISCHARGE BATTERY PARAMETERS
BATTERY CUTOFF VOLTAGE 4.68 REC. CELL CUTOFF VOLTAGE 1.70
CAPACITY OF BATTERY FOR THIS DISCHARGE 94.21 PERCENT
TOTAL BATTERY VOLTAGE 6.228
INDIVIDUAL CELL VOLTAGES SPECIFIC GRAVITY
CELL# 1 2.071 1.247
CELL# 5 2.083 1.248
CELL# 4 2.072 1.236

END OF CHARGE BATTERY ON FINISHING RATE
CHARGE NUMBER 50
TOTAL BATTERY VOLTAGE 8.031
INDIVIDUAL CELL VOLTAGES SPECIFIC GRAVITY
CELL# 1 2.646 1.266
CELL# 5 2.684 1.274
CELL# 4 2.702 1.272

DISCHARGE NUMBER 51
DISCHARGE CURRENT 3.20 DURATION OF DISCHARGE 5.45 HR.
RECORDED CELL # 1
START OF DISCHARGE BATTERY PARAMETERS
TOTAL BATTERY VOLTAGE 6.771
INDIVIDUAL CELL VOLTAGES SPECIFIC GRAVITY
CELL# 1 2.335 1.266
CELL# 5 2.223 1.274
CELL# 4 2.213 1.272

END OF DISCHARGE BATTERY PARAMETERS
BATTERY CUTOFF VOLTAGE 4.60 REC. CELL CUTOFF VOLTAGE 1.63
CAPACITY OF BATTERY FOR THIS DISCHARGE 94.21 PERCENT
TOTAL BATTERY VOLTAGE 6.204
INDIVIDUAL CELL VOLTAGES SPECIFIC GRAVITY
CELL# 1 2.062 1.245
CELL# 5 2.074 1.245
CELL# 4 2.064 1.235

END OF CHARGE BATTERY ON FINISHING RATE
CHARGE NUMBER 51
TOTAL BATTERY VOLTAGE 8.004
INDIVIDUAL CELL VOLTAGES SPECIFIC GRAVITY
CELL# 1 2.681 1.275
CELL# 5 2.715 1.276
CELL# 4 2.609 1.270

DISCHARGE NUMBER 52
DISCHARGE CURRENT 3.20 DURATION OF DISCHARGE 5.62 HR.
RECORDED CELL # 4
START OF DISCHARGE BATTERY PARAMETERS
TOTAL BATTERY VOLTAGE 7.030
INDIVIDUAL CELL VOLTAGES SPECIFIC GRAVITY
CELL# 1 2.448 1.275
CELL# 5 2.308 1.276
CELL# 4 2.274 1.270

THE RECORDED CELL CONTROLLED THE DISCHARGE
END OF DISCHARGE BATTERY PARAMETERS
BATTERY CUTOFF VOLTAGE 4.78 REC. CELL CUTOFF VOLTAGE 1.22
CAPACITY OF BATTERY FOR THIS DISCHARGE 97.08 PERCENT
TOTAL BATTERY VOLTAGE 6.204
INDIVIDUAL CELL VOLTAGES SPECIFIC GRAVITY
CELL# 1 2.064 1.249
CELL# 5 2.077 1.246
CELL# 4 2.063 1.240

END OF CHARGE BATTERY ON FINISHING RATE
CHARGE NUMBER 52
TOTAL BATTERY VOLTAGE 7.997
INDIVIDUAL CELL VOLTAGES SPECIFIC GRAVITY
CELL# 1 2.690 1.265
CELL# 5 2.730 1.272
CELL# 4 2.588 1.266

DISCHARGE NUMBER 53
DISCHARGE CURRENT 3.20 DURATION OF DISCHARGE 5.33 HR.
RECORDED CELL # 4
START OF DISCHARGE BATTERY PARAMETERS
TOTAL BATTERY VOLTAGE 6.682
INDIVIDUAL CELL VOLTAGES SPECIFIC GRAVITY
CELL# 1 2.258 1.265
CELL# 5 2.260 1.272
CELL# 4 2.165 1.266

THE RECORDED CELL CONTROLLED THE DISCHARGE
END OF DISCHARGE BATTERY PARAMETERS
BATTERY CUTOFF VOLTAGE 4.70 REC. CELL CUTOFF VOLTAGE 1.37
CAPACITY OF BATTERY FOR THIS DISCHARGE 92.19 PERCENT
TOTAL BATTERY VOLTAGE 6.114
INDIVIDUAL CELL VOLTAGES SPECIFIC GRAVITY
CELL# 1 2.031 1.244
CELL# 5 2.045 1.246
CELL# 4 2.028 1.237

END OF CHARGE BATTERY ON FINISHING RATE
CHARGE NUMBER 53
TOTAL BATTERY VOLTAGE 8.000
INDIVIDUAL CELL VOLTAGES SPECIFIC GRAVITY
CELL# 1 2.680 1.272
CELL# 5 2.726 1.276
CELL# 4 2.600 1.280

DISCHARGE NUMBER 54
DISCHARGE CURRENT 3.20 DURATION OF DISCHARGE 4.95 HR.
RECORDED CELL # 4
START OF DISCHARGE BATTERY PARAMETERS
TOTAL BATTERY VOLTAGE 7.101
INDIVIDUAL CELL VOLTAGES SPECIFIC GRAVITY
CELL# 1 2.495 1.272
CELL# 5 2.358 1.276
CELL# 4 2.261 1.280

THE RECORDED CELL CONTROLLED THE DISCHARGE
END OF DISCHARGE BATTERY PARAMETERS
BATTERY CUTOFF VOLTAGE 4.70 REC. CELL CUTOFF VOLTAGE 1.05
CAPACITY OF BATTERY FOR THIS DISCHARGE 85.57 PERCENT
TOTAL BATTERY VOLTAGE 6.237
INDIVIDUAL CELL VOLTAGES SPECIFIC GRAVITY
CELL# 1 2.079 1.252
CELL# 5 2.086 1.258
CELL# 4 2.069 1.244

END OF CHARGE BATTERY ON FINISHING RATE
CHARGE NUMBER 54
TOTAL BATTERY VOLTAGE 7.629
INDIVIDUAL CELL VOLTAGES SPECIFIC GRAVITY
CELL# 1 2.494 1.277
CELL# 5 2.716 1.282
CELL# 4 2.425 1.825

DISCHARGE NUMBER 55
DISCHARGE CURRENT 3.20 DURATION OF DISCHARGE 4.38 HR.
RECORDED CELL # 1
START OF DISCHARGE BATTERY PARAMETERS
TOTAL BATTERY VOLTAGE 6.455
INDIVIDUAL CELL VOLTAGES SPECIFIC GRAVITY
CELL# 1 2.108 1.277
CELL# 5 2.232 1.282
CELL# 4 2.115 1.285

END OF DISCHARGE BATTERY PARAMETERS
BATTERY CUTOFF VOLTAGE 4.70 REC. CELL CUTOFF VOLTAGE 1.80
CAPACITY OF BATTERY FOR THIS DISCHARGE 75.76 PERCENT
TOTAL BATTERY VOLTAGE 6.142
INDIVIDUAL CELL VOLTAGES SPECIFIC GRAVITY
CELL# 1 2.032 1.250
CELL# 5 2.086 1.250
CELL# 4 1.977 1.241

END OF CHARGE BATTERY ON FINISHING RATE
CHARGE NUMBER 55
TOTAL BATTERY VOLTAGE 7.962
INDIVIDUAL CELL VOLTAGES SPECIFIC GRAVITY
CELL# 1 2.590 1.269
CELL# 5 2.717 1.276
CELL# 4 2.655 1.279

DISCHARGE NUMBER 56
DISCHARGE CURRENT 3.20 DURATION OF DISCHARGE 4.73 HR.
RECORDED CELL # 4
START OF DISCHARGE BATTERY PARAMETERS
TOTAL BATTERY VOLTAGE 6.784
INDIVIDUAL CELL VOLTAGES SPECIFIC GRAVITY
CELL# 1 2.236 1.269
CELL# 5 2.323 1.276
CELL# 4 2.224 1.279

THE RECORDED CELL CONTROLLED THE DISCHARGE
END OF DISCHARGE BATTERY PARAMETERS
BATTERY CUTOFF VOLTAGE 4.53 REC. CELL CUTOFF VOLTAGE 1.00
CAPACITY OF BATTERY FOR THIS DISCHARGE 81.82 PERCENT
TOTAL BATTERY VOLTAGE 6.266
INDIVIDUAL CELL VOLTAGES SPECIFIC GRAVITY
CELL# 1 2.080 1.253
CELL# 5 2.100 1.253
CELL# 4 2.082 1.243

END OF CHARGE BATTERY ON FINISHING RATE
CHARGE NUMBER 56
TOTAL BATTERY VOLTAGE 8.065
INDIVIDUAL CELL VOLTAGES SPECIFIC GRAVITY
CELL# 1 2.632 1.265
CELL# 5 2.731 1.273
CELL# 4 2.699 1.275

DISCHARGE NUMBER 57
DISCHARGE CURRENT 3.20 DURATION OF DISCHARGE 4.60 HR.
RECORDED CELL # 1
START OF DISCHARGE BATTERY PARAMETERS
TOTAL BATTERY VOLTAGE 6.760
INDIVIDUAL CELL VOLTAGES SPECIFIC GRAVITY
CELL# 1 2.207 1.265
CELL# 5 2.303 1.273
CELL# 4 2.243 1.275

END OF DISCHARGE BATTERY PARAMETERS
BATTERY CUTOFF VOLTAGE 4.70 REC. CELL CUTOFF VOLTAGE 1.85
CAPACITY OF BATTERY FOR THIS DISCHARGE 79.52 PERCENT
TOTAL BATTERY VOLTAGE 6.319
INDIVIDUAL CELL VOLTAGES SPECIFIC GRAVITY
CELL# 1 2.105 1.253
CELL# 5 2.117 1.251
CELL# 4 2.097 1.241

END OF CHARGE BATTERY ON FINISHING RATE
CHARGE NUMBER 57
TOTAL BATTERY VOLTAGE 8.104
INDIVIDUAL CELL VOLTAGES SPECIFIC GRAVITY
CELL# 1 2.643 1.279
CELL# 5 2.744 1.288
CELL# 4 2.717 1.276

DISCHARGE NUMBER 58
DISCHARGE CURRENT 3.20 DURATION OF DISCHARGE 4.68 HR.
RECORDED CELL # 4
START OF DISCHARGE BATTERY PARAMETERS
TOTAL BATTERY VOLTAGE 7.219
INDIVIDUAL CELL VOLTAGES SPECIFIC GRAVITY
CELL# 1 2.455 1.279
CELL# 5 2.399 1.288
CELL# 4 2.384 1.276

END OF DISCHARGE BATTERY PARAMETERS
BATTERY CUTOFF VOLTAGE 4.68 REC. CELL CUTOFF VOLTAGE 1.59
CAPACITY OF BATTERY FOR THIS DISCHARGE 80.95 PERCENT
TOTAL BATTERY VOLTAGE 6.278
INDIVIDUAL CELL VOLTAGES SPECIFIC GRAVITY
CELL# 1 2.086 1.254
CELL# 5 2.102 1.254
CELL# 4 2.090 1.241

END OF CHARGE BATTERY ON FINISHING RATE
CHARGE NUMBER 58
TOTAL BATTERY VOLTAGE 8.091
INDIVIDUAL CELL VOLTAGES SPECIFIC GRAVITY
CELL# 1 2.630 1.285
CELL# 5 2.742 1.290
CELL# 4 2.719 1.279

DISCHARGE NUMBER 59

DISCHARGE CURRENT 3.20 DURATION OF DISCHARGE 4.57 HR.
RECORDED CELL # 1
START OF DISCHARGE BATTERY PARAMETERS
TOTAL BATTERY VOLTAGE 6.971
INDIVIDUAL CELL VOLTAGES SPECIFIC GRAVITY
CELL# 1 2.320 1.285
CELL# 5 2.383 1.290
CELL# 4 2.360 1.279

END OF DISCHARGE BATTERY PARAMETERS
BATTERY CUTOFF VOLTAGE 4.68 REC. CELL CUTOFF VOLTAGE 1.75
CAPACITY OF BATTERY FOR THIS DISCHARGE 78.93 PERCENT
TOTAL BATTERY VOLTAGE 6.180
INDIVIDUAL CELL VOLTAGES SPECIFIC GRAVITY
CELL# 1 2.045 1.256
CELL# 5 2.074 1.260
CELL# 4 2.061 1.245

END OF CHARGE BATTERY ON FINISHING RATE
CHARGE NUMBER 59
TOTAL BATTERY VOLTAGE 7.758
INDIVIDUAL CELL VOLTAGES SPECIFIC GRAVITY
CELL# 1 2.482 1.273
CELL# 5 2.725 1.281
CELL# 4 2.551 1.275

DISCHARGE NUMBER 60
DISCHARGE CURRENT 3.20 DURATION OF DISCHARGE 4.05 HR.
RECORDED CELL # 1
START OF DISCHARGE BATTERY PARAMETERS
TOTAL BATTERY VOLTAGE 6.880
INDIVIDUAL CELL VOLTAGES SPECIFIC GRAVITY
CELL# 1 2.250 1.273
CELL# 5 2.360 1.281
CELL# 4 2.289 1.275

THE RECORDED CELL CONTROLLED THE DISCHARGE
END OF DISCHARGE BATTERY PARAMETERS
BATTERY CUTOFF VOLTAGE 4.73 REC. CELL CUTOFF VOLTAGE 1.00
CAPACITY OF BATTERY FOR THIS DISCHARGE 70.01 PERCENT
TOTAL BATTERY VOLTAGE 6.232
INDIVIDUAL CELL VOLTAGES SPECIFIC GRAVITY
CELL# 1 2.026 1.255
CELL# 5 2.109 1.260
CELL# 4 2.094 1.247

END OF CHARGE BATTERY ON FINISHING RATE
CHARGE NUMBER 60
TOTAL BATTERY VOLTAGE 7.609
INDIVIDUAL CELL VOLTAGES SPECIFIC GRAVITY
CELL# 1 2.386 1.275
CELL# 5 2.720 1.285
CELL# 4 2.510 1.275

APPENDIX D

CYCLE HISTORY OF PBCA # 1

DISCHARGE NUMBER 1
 DISCHARGE CURRENT 2.60 DURATION OF DISCHARGE 6.42 HR.
 RECORDED CELL # 3
 START OF DISCHARGE BATTERY PARAMETERS
 TOTAL BATTERY VOLTAGE 6.645
 INDIVIDUAL CELL VOLTAGES SPECIFIC GRAVITY
 CELL# 1 2.223 1.271
 CELL# 2 2.225 1.270
 CELL# 3 2.198 1.269

THE RECORDED CELL CONTROLLED THE DISCHARGE
 END OF DISCHARGE BATTERY PARAMETERS
 BATTERY CUTOFF VOLTAGE 5.39 REC. CELL CUTOFF VOLTAGE 1.63
 CAPACITY OF BATTERY FOR THIS DISCHARGE 83.62 PERCENT
 TOTAL BATTERY VOLTAGE 6.098
 INDIVIDUAL CELL VOLTAGES SPECIFIC GRAVITY
 CELL# 1 1.981 1.235
 CELL# 2 2.009 1.225
 CELL# 3 2.008 1.226

DISCHARGE NUMBER 2
 DISCHARGE CURRENT 1.80 DURATION OF DISCHARGE 10.33 HR.
 RECORDED CELL # 1
 START OF DISCHARGE BATTERY PARAMETERS
 TOTAL BATTERY VOLTAGE 6.618
 INDIVIDUAL CELL VOLTAGES SPECIFIC GRAVITY
 CELL# 1 2.184 1.267
 CELL# 2 2.200 1.267
 CELL# 3 2.208 1.267

END OF DISCHARGE BATTERY PARAMETERS
 BATTERY CUTOFF VOLTAGE 4.85 REC. CELL CUTOFF VOLTAGE 1.90
 CAPACITY OF BATTERY FOR THIS DISCHARGE 83.19 PERCENT
 TOTAL BATTERY VOLTAGE 5.856
 INDIVIDUAL CELL VOLTAGES SPECIFIC GRAVITY
 CELL# 1 1.981 1.222
 CELL# 2 1.986 1.223
 CELL# 3 1.825 1.225

END OF CHARGE BATTERY ON OPEN CIRCUIT
 CHARGE NUMBER 2
 TOTAL BATTERY VOLTAGE 6.863
 INDIVIDUAL CELL VOLTAGES SPECIFIC GRAVITY
 CELL# 1 2.302 1.268
 CELL# 2 2.304 1.268
 CELL# 3 2.281 1.268

DISCHARGE NUMBER 3
 DISCHARGE CURRENT 2.60 DURATION OF DISCHARGE 6.32 HR.
 RECORDED CELL # 1
 START OF DISCHARGE BATTERY PARAMETERS
 TOTAL BATTERY VOLTAGE 6.404
 INDIVIDUAL CELL VOLTAGES SPECIFIC GRAVITY
 CELL# 1 2.137 1.271
 CELL# 2 2.135 1.271
 CELL# 3 2.132 1.270

END OF DISCHARGE BATTERY PARAMETERS

BATTERY CUTOFF VOLTAGE 5.16 REC. CELL CUTOFF VOLTAGE 1.89
CAPACITY OF BATTERY FOR THIS DISCHARGE 82.32 PERCENT
TOTAL BATTERY VOLTAGE 6.035
INDIVIDUAL CELL VOLTAGES SPECIFIC GRAVITY
CELL# 1 2.024 1.235
CELL# 2 2.025 1.236
CELL# 3 1.997 1.236

DISCHARGE NUMBER 4
DISCHARGE CURRENT 1.80 DURATION OF DISCHARGE 10.08 HR.
RECORDED CELL # 3
START OF DISCHARGE BATTERY PARAMETERS
TOTAL BATTERY VOLTAGE 6.590
INDIVIDUAL CELL VOLTAGES SPECIFIC GRAVITY
CELL# 1 2.201 1.268
CELL# 2 2.200 1.268
CELL# 3 2.189 1.265

THE RECORDED CELL CONTROLLED THE DISCHARGE
END OF DISCHARGE BATTERY PARAMETERS
BATTERY CUTOFF VOLTAGE 5.16 REC. CELL CUTOFF VOLTAGE 1.50
CAPACITY OF BATTERY FOR THIS DISCHARGE 81.18 PERCENT
TOTAL BATTERY VOLTAGE 5.836
INDIVIDUAL CELL VOLTAGES SPECIFIC GRAVITY
CELL# 1 1.990 1.220
CELL# 2 1.997 1.223
CELL# 3 1.826 1.225

DISCHARGE NUMBER 5
DISCHARGE CURRENT 2.60 DURATION OF DISCHARGE 7.00 HR.
RECORDED CELL # 2
START OF DISCHARGE BATTERY PARAMETERS
TOTAL BATTERY VOLTAGE 6.514
INDIVIDUAL CELL VOLTAGES SPECIFIC GRAVITY
CELL# 1 2.174 1.275
CELL# 2 2.171 1.275
CELL# 3 2.170 1.276

END OF DISCHARGE BATTERY PARAMETERS
BATTERY CUTOFF VOLTAGE 5.00 REC. CELL CUTOFF VOLTAGE 1.90
CAPACITY OF BATTERY FOR THIS DISCHARGE 91.23 PERCENT
TOTAL BATTERY VOLTAGE 6.225
INDIVIDUAL CELL VOLTAGES SPECIFIC GRAVITY
CELL# 1 2.082 1.227
CELL# 2 2.081 1.225
CELL# 3 2.076 1.221

DISCHARGE NUMBER 6
DISCHARGE CURRENT 2.60 DURATION OF DISCHARGE 6.78 HR.
RECORDED CELL # 3
START OF DISCHARGE BATTERY PARAMETERS
TOTAL BATTERY VOLTAGE 6.486
INDIVIDUAL CELL VOLTAGES SPECIFIC GRAVITY
CELL# 1 2.160 1.266
CELL# 2 2.161 1.265
CELL# 3 2.163 1.261

THE RECORDED CELL CONTROLLED THE DISCHARGE
END OF DISCHARGE BATTERY PARAMETERS
BATTERY CUTOFF VOLTAGE 4.93 REC. CELL CUTOFF VOLTAGE 1.17
CAPACITY OF BATTERY FOR THIS DISCHARGE 88.36 PERCENT
TOTAL BATTERY VOLTAGE 6.181
INDIVIDUAL CELL VOLTAGES SPECIFIC GRAVITY
CELL# 1 2.065 1.225
CELL# 2 2.063 1.220
CELL# 3 2.053 1.225

END OF CHARGE BATTERY ON OPEN CIRCUIT

CHARGE NUMBER 6
TOTAL BATTERY VOLTAGE 6.656
INDIVIDUAL CELL VOLTAGES SPECIFIC GRAVITY
CELL# 1 2.232 1.276
CELL# 2 2.220 1.279
CELL# 3 2.195 1.276

DISCHARGE NUMBER 7
DISCHARGE CURRENT 2.60 DURATION OF DISCHARGE 7.43 HR.

RECORDED CELL # 3
START OF DISCHARGE BATTERY PARAMETERS
TOTAL BATTERY VOLTAGE 6.433
INDIVIDUAL CELL VOLTAGES SPECIFIC GRAVITY
CELL# 1 2.142 1.278
CELL# 2 2.143 1.278
CELL# 3 2.148 1.278

THE RECORDED CELL CONTROLLED THE DISCHARGE

END OF DISCHARGE BATTERY PARAMETERS
BATTERY CUTOFF VOLTAGE 5.10 REC. CELL CUTOFF VOLTAGE 1.31
CAPACITY OF BATTERY FOR THIS DISCHARGE 96.87 PERCENT
TOTAL BATTERY VOLTAGE 5.898
INDIVIDUAL CELL VOLTAGES SPECIFIC GRAVITY
CELL# 1 ***** 1.238
CELL# 2 1.960 1.236
CELL# 3 1.920 1.231

END OF CHARGE BATTERY ON OPEN CIRCUIT

CHARGE NUMBER 7
TOTAL BATTERY VOLTAGE 6.514
INDIVIDUAL CELL VOLTAGES SPECIFIC GRAVITY
CELL# 1 2.171 1.270
CELL# 2 2.171 1.271
CELL# 3 2.171 1.271

DISCHARGE NUMBER 8
DISCHARGE CURRENT 2.80 DURATION OF DISCHARGE 6.60 HR.

RECORDED CELL # 3
START OF DISCHARGE BATTERY PARAMETERS
TOTAL BATTERY VOLTAGE 6.402
INDIVIDUAL CELL VOLTAGES SPECIFIC GRAVITY
CELL# 1 2.134 1.280
CELL# 2 2.134 1.280
CELL# 3 2.134 1.280

THE RECORDED CELL CONTROLLED THE DISCHARGE

END OF DISCHARGE BATTERY PARAMETERS
BATTERY CUTOFF VOLTAGE 5.12 REC. CELL CUTOFF VOLTAGE 1.35
CAPACITY OF BATTERY FOR THIS DISCHARGE 94.79 PERCENT
TOTAL BATTERY VOLTAGE 6.176
INDIVIDUAL CELL VOLTAGES SPECIFIC GRAVITY
CELL# 1 2.060 1.220
CELL# 2 2.061 1.223
CELL# 3 2.055 1.230

DISCHARGE NUMBER 9
DISCHARGE CURRENT 3.00 DURATION OF DISCHARGE 6.57 HR.

RECORDED CELL # 1
START OF DISCHARGE BATTERY PARAMETERS
TOTAL BATTERY VOLTAGE 6.660
INDIVIDUAL CELL VOLTAGES SPECIFIC GRAVITY
CELL# 1 2.225 1.271
CELL# 2 2.221 1.270

CELL# 3 2.221

1.271

END OF DISCHARGE BATTERY PARAMETERS
BATTERY CUTOFF VOLTAGE 5.20 REC. CELL CUTOFF VOLTAGE 1.88
CAPACITY OF BATTERY FOR THIS DISCHARGE 103.22 PERCENT
TOTAL BATTERY VOLTAGE 6.133
INDIVIDUAL CELL VOLTAGES SPECIFIC GRAVITY
CELL# 1 2.045 1.220
CELL# 2 2.047 1.220
CELL# 3 2.039 1.230
DISCHARGE NUMBER 10
DISCHARGE CURRENT 2.88 DURATION OF DISCHARGE 6.37 HR.
RECORDED CELL # 2
START OF DISCHARGE BATTERY PARAMETERS
TOTAL BATTERY VOLTAGE 6.576
INDIVIDUAL CELL VOLTAGES SPECIFIC GRAVITY
CELL# 1 2.192 1.262
CELL# 2 2.192 1.261
CELL# 3 2.189 1.261

END OF DISCHARGE BATTERY PARAMETERS
BATTERY CUTOFF VOLTAGE 5.10 REC. CELL CUTOFF VOLTAGE 1.89
CAPACITY OF BATTERY FOR THIS DISCHARGE 94.86 PERCENT
TOTAL BATTERY VOLTAGE 6.177
INDIVIDUAL CELL VOLTAGES SPECIFIC GRAVITY
CELL# 1 2.061 1.215
CELL# 2 2.061 2.061
CELL# 3 2.044 1.226

DISCHARGE NUMBER 11
DISCHARGE CURRENT 2.80 DURATION OF DISCHARGE 6.58 HR.
RECORDED CELL # 4
START OF DISCHARGE BATTERY PARAMETERS
TOTAL BATTERY VOLTAGE 6.477
INDIVIDUAL CELL VOLTAGES SPECIFIC GRAVITY
CELL# 1 2.168 1.251
CELL# 2 2.170 1.250
CELL# 4 2.136 1.265

THE RECORDED CELL CONTROLLED THE DISCHARGE
END OF DISCHARGE BATTERY PARAMETERS
BATTERY CUTOFF VOLTAGE 5.30 REC. CELL CUTOFF VOLTAGE 1.74
CAPACITY OF BATTERY FOR THIS DISCHARGE 94.54 PERCENT
TOTAL BATTERY VOLTAGE 5.884
INDIVIDUAL CELL VOLTAGES SPECIFIC GRAVITY
CELL# 1 1.950 1.210
CELL# 2 1.968 1.209
CELL# 4 1.944 1.209

END OF CHARGE BATTERY ON FINISHING RATE
CHARGE NUMBER 11
TOTAL BATTERY VOLTAGE 7.950
INDIVIDUAL CELL VOLTAGES SPECIFIC GRAVITY
CELL# 1 2.660 1.275
CELL# 2 2.660 1.272
CELL# 4 2.630 1.266

DISCHARGE NUMBER 12
DISCHARGE CURRENT 2.80 DURATION OF DISCHARGE 6.22 HR.
RECORDED CELL # 1
START OF DISCHARGE BATTERY PARAMETERS
TOTAL BATTERY VOLTAGE 6.448
INDIVIDUAL CELL VOLTAGES SPECIFIC GRAVITY
CELL# 1 2.156 1.276
CELL# 2 2.156 1.275
CELL# 4 2.134 1.268

END OF DISCHARGE BATTERY PARAMETERS
BATTERY CUTOFF VOLTAGE 4.77 REC. CELL CUTOFF VOLTAGE 1.90
CAPACITY OF BATTERY FOR THIS DISCHARGE 89.27 PERCENT
TOTAL BATTERY VOLTAGE 5.982
INDIVIDUAL CELL VOLTAGES SPECIFIC GRAVITY
CELL# 1 2.011 1.223
CELL# 2 2.014 1.223
CELL# 4 1.965 1.215

END OF CHARGE BATTERY ON FINISHING RATE
CHARGE NUMBER 12
TOTAL BATTERY VOLTAGE 7.951
INDIVIDUAL CELL VOLTAGES SPECIFIC GRAVITY
CELL# 1 2.654 1.261
CELL# 2 2.636 1.260
CELL# 4 2.661 1.258

DISCHARGE NUMBER 13
DISCHARGE CURRENT 2.80 DURATION OF DISCHARGE 6.13 HR.
RECORDED CELL # 2
START OF DISCHARGE BATTERY PARAMETERS
TOTAL BATTERY VOLTAGE 6.559
INDIVIDUAL CELL VOLTAGES SPECIFIC GRAVITY
CELL# 1 2.197 1.261
CELL# 2 2.195 1.260
CELL# 4 2.167 1.258

END OF DISCHARGE BATTERY PARAMETERS
BATTERY CUTOFF VOLTAGE 4.85 REC. CELL CUTOFF VOLTAGE 1.90
CAPACITY OF BATTERY FOR THIS DISCHARGE 88.08 PERCENT
TOTAL BATTERY VOLTAGE 6.222
INDIVIDUAL CELL VOLTAGES SPECIFIC GRAVITY
CELL# 1 2.079 1.223
CELL# 2 2.079 1.215
CELL# 4 2.062 1.210

END OF CHARGE BATTERY ON FINISHING RATE
CHARGE NUMBER 13
TOTAL BATTERY VOLTAGE 7.960
INDIVIDUAL CELL VOLTAGES SPECIFIC GRAVITY
CELL# 1 2.658 1.272
CELL# 2 2.643 1.260
CELL# 4 2.659 1.253

DISCHARGE NUMBER 14
DISCHARGE CURRENT 2.80 DURATION OF DISCHARGE 6.25 HR.
RECORDED CELL # 4
START OF DISCHARGE BATTERY PARAMETERS
TOTAL BATTERY VOLTAGE 6.486
INDIVIDUAL CELL VOLTAGES SPECIFIC GRAVITY
CELL# 1 2.171 1.265
CELL# 2 2.169 1.270
CELL# 4 2.146 1.271

THE RECORDED CELL CONTROLLED THE DISCHARGE
END OF DISCHARGE BATTERY PARAMETERS
BATTERY CUTOFF VOLTAGE 4.87 REC. CELL CUTOFF VOLTAGE 1.10
CAPACITY OF BATTERY FOR THIS DISCHARGE 89.76 PERCENT
TOTAL BATTERY VOLTAGE 6.214
INDIVIDUAL CELL VOLTAGES SPECIFIC GRAVITY
CELL# 1 2.075 1.220
CELL# 2 2.075 1.222
CELL# 4 2.063 1.210

END OF CHARGE BATTERY ON FINISHING RATE
CHARGE NUMBER 14
TOTAL BATTERY VOLTAGE 7.951
INDIVIDUAL CELL VOLTAGES SPECIFIC GRAVITY
CELL# 1 2.658 1.260
CELL# 2 2.642 1.260
CELL# 4 2.651 1.250

DISCHARGE NUMBER 15
DISCHARGE CURRENT 2.80 DURATION OF DISCHARGE 6.32 HR.
RECORDED CELL # 1
START OF DISCHARGE BATTERY PARAMETERS
TOTAL BATTERY VOLTAGE 6.738
INDIVIDUAL CELL VOLTAGES SPECIFIC GRAVITY
CELL# 1 2.254 1.260
CELL# 2 2.249 1.260
CELL# 4 2.235 1.260

END OF DISCHARGE BATTERY PARAMETERS
BATTERY CUTOFF VOLTAGE 4.75 REC. CELL CUTOFF VOLTAGE 1.89
CAPACITY OF BATTERY FOR THIS DISCHARGE 90.71 PERCENT
TOTAL BATTERY VOLTAGE 6.209
INDIVIDUAL CELL VOLTAGES SPECIFIC GRAVITY
CELL# 1 2.076 1.205
CELL# 2 2.075 1.217
CELL# 4 2.058 1.200

END OF CHARGE BATTERY ON FINISHING RATE
CHARGE NUMBER 15
TOTAL BATTERY VOLTAGE 7.945
INDIVIDUAL CELL VOLTAGES SPECIFIC GRAVITY
CELL# 1 2.656 1.273
CELL# 2 2.639 1.270
CELL# 4 2.649 1.264

DISCHARGE NUMBER 16
DISCHARGE CURRENT 3.60 DURATION OF DISCHARGE 4.53 HR.
RECORDED CELL # 2
START OF DISCHARGE BATTERY PARAMETERS
TOTAL BATTERY VOLTAGE 6.602
INDIVIDUAL CELL VOLTAGES SPECIFIC GRAVITY
CELL# 1 2.205 1.273
CELL# 2 2.204 1.270
CELL# 4 2.186 1.264

THE RECORDED CELL CONTROLLED THE DISCHARGE
END OF DISCHARGE BATTERY PARAMETERS
BATTERY CUTOFF VOLTAGE 5.05 REC. CELL CUTOFF VOLTAGE 1.50
CAPACITY OF BATTERY FOR THIS DISCHARGE 90.48 PERCENT
TOTAL BATTERY VOLTAGE 5.861
INDIVIDUAL CELL VOLTAGES SPECIFIC GRAVITY
CELL# 1 1.995 1.205
CELL# 2 1.915 1.200
CELL# 4 1.968 1.203

END OF CHARGE BATTERY ON FINISHING RATE
CHARGE NUMBER 16
TOTAL BATTERY VOLTAGE 7.962
INDIVIDUAL CELL VOLTAGES SPECIFIC GRAVITY
CELL# 1 2.673 1.270
CELL# 2 2.609 1.253
CELL# 4 2.680 1.270

DISCHARGE NUMBER 17

DISCHARGE CURRENT 2.80 DURATION OF DISCHARGE 6.80 HR.
RECORDED CELL # 4
START OF DISCHARGE BATTERY PARAMETERS
TOTAL BATTERY VOLTAGE 6.547
INDIVIDUAL CELL VOLTAGES SPECIFIC GRAVITY
CELL# 1 2.184 1.270
CELL# 2 2.190 1.256
CELL# 4 2.173 1.269

END OF DISCHARGE BATTERY PARAMETERS
BATTERY CUTOFF VOLTAGE 4.80 REC. CELL CUTOFF VOLTAGE 1.72
CAPACITY OF BATTERY FOR THIS DISCHARGE 97.66 PERCENT
TOTAL BATTERY VOLTAGE 6.154
INDIVIDUAL CELL VOLTAGES SPECIFIC GRAVITY
CELL# 1 2.062 1.212
CELL# 2 2.047 1.207
CELL# 4 2.044 1.212

DISCHARGE NUMBER 18
DISCHARGE CURRENT 2.80 DURATION OF DISCHARGE 6.62 HR.
RECORDED CELL # 1
START OF DISCHARGE BATTERY PARAMETERS
TOTAL BATTERY VOLTAGE 6.520
INDIVIDUAL CELL VOLTAGES SPECIFIC GRAVITY
CELL# 1 2.180 1.268
CELL# 2 2.177 1.266
CELL# 4 2.162 1.258

END OF DISCHARGE BATTERY PARAMETERS
BATTERY CUTOFF VOLTAGE 4.82 REC. CELL CUTOFF VOLTAGE 1.87
CAPACITY OF BATTERY FOR THIS DISCHARGE 95.01 PERCENT
TOTAL BATTERY VOLTAGE 5.972
INDIVIDUAL CELL VOLTAGES SPECIFIC GRAVITY
CELL# 1 2.001 1.216
CELL# 2 1.978 1.212
CELL# 4 1.983 1.207

END OF CHARGE BATTERY ON FINISHING RATE
CHARGE NUMBER 18
TOTAL BATTERY VOLTAGE 7.960
INDIVIDUAL CELL VOLTAGES SPECIFIC GRAVITY
CELL# 1 ***** 1.279
CELL# 2 ***** 1.280
CELL# 4 2.670 1.271

DISCHARGE NUMBER 19
DISCHARGE CURRENT 4.50 DURATION OF DISCHARGE 3.67 HR.
RECORDED CELL # 2
START OF DISCHARGE BATTERY PARAMETERS
TOTAL BATTERY VOLTAGE 6.447
INDIVIDUAL CELL VOLTAGES SPECIFIC GRAVITY
CELL# 1 2.154 1.278
CELL# 2 2.153 1.278
CELL# 4 2.139 1.275

END OF DISCHARGE BATTERY PARAMETERS
BATTERY CUTOFF VOLTAGE 4.77 REC. CELL CUTOFF VOLTAGE 1.88
CAPACITY OF BATTERY FOR THIS DISCHARGE 98.02 PERCENT
TOTAL BATTERY VOLTAGE 6.009
INDIVIDUAL CELL VOLTAGES SPECIFIC GRAVITY
CELL# 1 2.015 1.215
CELL# 2 2.009 1.220
CELL# 4 1.988 1.215

END OF CHARGE BATTERY ON FINISHING RATE

CHARGE NUMBER 19
TOTAL BATTERY VOLTAGE 7.927
INDIVIDUAL CELL VOLTAGES SPECIFIC GRAVITY
CELL# 1 2.653 1.277
CELL# 2 2.621 1.259
CELL# 4 2.652 1.273

DISCHARGE NUMBER 20
DISCHARGE CURRENT 3.60 DURATION OF DISCHARGE 4.77 HR.
RECORDED CELL # 4
START OF DISCHARGE BATTERY PARAMETERS
TOTAL BATTERY VOLTAGE 6.450
INDIVIDUAL CELL VOLTAGES SPECIFIC GRAVITY
CELL# 1 2.156 1.282
CELL# 2 2.153 1.281
CELL# 4 2.139 1.276

THE RECORDED CELL CONTROLLED THE DISCHARGE
END OF DISCHARGE BATTERY PARAMETERS
BATTERY CUTOFF VOLTAGE 4.89 REC. CELL CUTOFF VOLTAGE 1.52
CAPACITY OF BATTERY FOR THIS DISCHARGE 95.13 PERCENT
TOTAL BATTERY VOLTAGE 6.151
INDIVIDUAL CELL VOLTAGES SPECIFIC GRAVITY
CELL# 1 2.056 1.230
CELL# 2 2.051 1.223
CELL# 4 2.042 1.226

END OF CHARGE BATTERY ON FINISHING RATE
CHARGE NUMBER 20
TOTAL BATTERY VOLTAGE 7.971
INDIVIDUAL CELL VOLTAGES SPECIFIC GRAVITY
CELL# 1 2.664 1.279
CELL# 2 2.634 1.282
CELL# 4 2.663 1.276

DISCHARGE NUMBER 21
DISCHARGE CURRENT 2.80 DURATION OF DISCHARGE 6.58 HR.
RECORDED CELL # 5
START OF DISCHARGE BATTERY PARAMETERS
TOTAL BATTERY VOLTAGE 9.903
INDIVIDUAL CELL VOLTAGES SPECIFIC GRAVITY
CELL# 1 2.198 1.278
CELL# 5 2.215 1.270
CELL# 4 2.190 1.275

THE RECORDED CELL CONTROLLED THE DISCHARGE
END OF DISCHARGE BATTERY PARAMETERS
BATTERY CUTOFF VOLTAGE 4.78 REC. CELL CUTOFF VOLTAGE 1.27
CAPACITY OF BATTERY FOR THIS DISCHARGE 94.54 PERCENT
TOTAL BATTERY VOLTAGE 6.008
INDIVIDUAL CELL VOLTAGES SPECIFIC GRAVITY
CELL# 1 2.031 1.235
CELL# 2 1.969 1.223
CELL# 4 2.008 1.225

END OF CHARGE BATTERY ON FINISHING RATE
CHARGE NUMBER 21
TOTAL BATTERY VOLTAGE 7.929
INDIVIDUAL CELL VOLTAGES SPECIFIC GRAVITY
CELL# 1 2.653 1.279
CELL# 5 2.630 1.270
CELL# 4 2.651 1.271

DISCHARGE NUMBER 22
DISCHARGE CURRENT 2.30 DURATION OF DISCHARGE 8.08 HR.

RECORDED CELL # 1
START OF DISCHARGE BATTERY PARAMETERS
TOTAL BATTERY VOLTAGE 6.642
INDIVIDUAL CELL VOLTAGES SPECIFIC GRAVITY
CELL# 1 2.232 1.279
CELL# 5 2.194 1.270
CELL# 4 2.216 1.271

END OF DISCHARGE BATTERY PARAMETERS
BATTERY CUTOFF VOLTAGE 4.69 REC. CELL CUTOFF VOLTAGE 1.86
CAPACITY OF BATTERY FOR THIS DISCHARGE 89.71 PERCENT
TOTAL BATTERY VOLTAGE 5.855
INDIVIDUAL CELL VOLTAGES SPECIFIC GRAVITY
CELL# 1 1.669 1.229
CELL# 5 1.914 1.226
CELL# 4 1.972 1.223

END OF CHARGE BATTERY ON FINISHING RATE
CHARGE NUMBER 22
TOTAL BATTERY VOLTAGE 8.021
INDIVIDUAL CELL VOLTAGES SPECIFIC GRAVITY
CELL# 1 2.670 1.278
CELL# 5 2.669 1.264
CELL# 4 2.680 1.274

DISCHARGE NUMBER 23
DISCHARGE CURRENT 2.60 DURATION OF DISCHARGE 6.98 HR.
RECORDED CELL # 5
START OF DISCHARGE BATTERY PARAMETERS
TOTAL BATTERY VOLTAGE 6.629
INDIVIDUAL CELL VOLTAGES SPECIFIC GRAVITY
CELL# 1 2.232 1.278
CELL# 5 2.197 1.282
CELL# 4 2.224 1.282

THE RECORDED CELL CONTROLLED THE DISCHARGE
END OF DISCHARGE BATTERY PARAMETERS
BATTERY CUTOFF VOLTAGE 4.90 REC. CELL CUTOFF VOLTAGE 1.20
CAPACITY OF BATTERY FOR THIS DISCHARGE 89.70 PERCENT
TOTAL BATTERY VOLTAGE 6.066
INDIVIDUAL CELL VOLTAGES SPECIFIC GRAVITY
CELL# 1 2.044 1.232
CELL# 5 2.006 1.245
CELL# 4 2.046 1.242

END OF CHARGE BATTERY ON FINISHING RATE
CHARGE NUMBER 23
TOTAL BATTERY VOLTAGE 8.013
INDIVIDUAL CELL VOLTAGES SPECIFIC GRAVITY
CELL# 1 2.672 1.279
CELL# 5 2.655 1.283
CELL# 4 2.686 1.284

DISCHARGE NUMBER 24
DISCHARGE CURRENT 3.50 DURATION OF DISCHARGE 4.92 HR.
RECORDED CELL # 1
START OF DISCHARGE BATTERY PARAMETERS
TOTAL BATTERY VOLTAGE 6.647
INDIVIDUAL CELL VOLTAGES SPECIFIC GRAVITY
CELL# 1 2.221 1.279
CELL# 5 2.200 1.279
CELL# 4 2.226 1.279

END OF DISCHARGE BATTERY PARAMETERS
BATTERY CUTOFF VOLTAGE 4.70 REC. CELL CUTOFF VOLTAGE 1.85

CAPACITY OF BATTERY FOR THIS DISCHARGE 94.57 PERCENT
TOTAL BATTERY VOLTAGE 5.958
INDIVIDUAL CELL VOLTAGES SPECIFIC GRAVITY
CELL# 1 2.001 1.202
CELL# 5 1.645 1.247
CELL# 4 2.005 1.250

END OF CHARGE BATTERY ON FINISHING RATE
CHARGE NUMBER 24
TOTAL BATTERY VOLTAGE 7.998
INDIVIDUAL CELL VOLTAGES SPECIFIC GRAVITY
CELL# 1 2.668 1.282
CELL# 5 2.647 1.280
CELL# 4 2.681 1.280

DISCHARGE NUMBER 25
DISCHARGE CURRENT 3.00 DURATION OF DISCHARGE 6.10 HR.
RECORDED CELL # 4
START OF DISCHARGE BATTERY PARAMETERS
TOTAL BATTERY VOLTAGE 6.586
INDIVIDUAL CELL VOLTAGES SPECIFIC GRAVITY
CELL# 1 2.213 1.282
CELL# 5 2.191 1.280
CELL# 4 2.209 1.280

END OF DISCHARGE BATTERY PARAMETERS
BATTERY CUTOFF VOLTAGE 4.65 REC. CELL CUTOFF VOLTAGE 1.86
CAPACITY OF BATTERY FOR THIS DISCHARGE 95.89 PERCENT
TOTAL BATTERY VOLTAGE 6.232
INDIVIDUAL CELL VOLTAGES SPECIFIC GRAVITY
CELL# 1 2.077 1.240
CELL# 5 2.071 1.238
CELL# 4 2.084 1.245

END OF CHARGE BATTERY ON FINISHING RATE
CHARGE NUMBER 25
TOTAL BATTERY VOLTAGE 7.913
INDIVIDUAL CELL VOLTAGES SPECIFIC GRAVITY
CELL# 1 2.650 1.276
CELL# 5 2.627 1.274
CELL# 4 2.663 1.280

DISCHARGE NUMBER 26
DISCHARGE CURRENT 4.70 DURATION OF DISCHARGE 3.53 HR.
RECORDED CELL # 1
START OF DISCHARGE BATTERY PARAMETERS
TOTAL BATTERY VOLTAGE 6.675
INDIVIDUAL CELL VOLTAGES SPECIFIC GRAVITY
CELL# 1 2.232 1.276
CELL# 5 2.211 1.274
CELL# 4 2.232 1.280

END OF DISCHARGE BATTERY PARAMETERS
BATTERY CUTOFF VOLTAGE 4.80 REC. CELL CUTOFF VOLTAGE 1.84
CAPACITY OF BATTERY FOR THIS DISCHARGE 100.00 PERCENT
TOTAL BATTERY VOLTAGE 5.904
INDIVIDUAL CELL VOLTAGES SPECIFIC GRAVITY
CELL# 1 1.976 1.246
CELL# 5 1.927 1.242
CELL# 4 1.982 1.247

END OF CHARGE BATTERY ON FINISHING RATE
CHARGE NUMBER 26
TOTAL BATTERY VOLTAGE 7.622
INDIVIDUAL CELL VOLTAGES SPECIFIC GRAVITY

CELL# 1 2.663 1.282
CELL# 5 2.679 1.252
CELL# 4 2.672 1.278

DISCHARGE NUMBER 27
DISCHARGE CURRENT 3.00 DURATION OF DISCHARGE 6.07 HR.
RECORDED CELL # 5
START OF DISCHARGE BATTERY PARAMETERS
TOTAL BATTERY VOLTAGE 6.648
INDIVIDUAL CELL VOLTAGES SPECIFIC GRAVITY
CELL# 1 2.209 1.282
CELL# 5 2.252 1.282
CELL# 4 2.205 1.278

THE RECORDED CELL CONTROLLED THE DISCHARGE
END OF DISCHARGE BATTERY PARAMETERS
BATTERY CUTOFF VOLTAGE 4.73 REC. CELL CUTOFF VOLTAGE 1.15
CAPACITY OF BATTERY FOR THIS DISCHARGE 95.36 PERCENT
TOTAL BATTERY VOLTAGE 6.043
INDIVIDUAL CELL VOLTAGES SPECIFIC GRAVITY
CELL# 1 2.015 1.231
CELL# 5 2.005 1.236
CELL# 4 2.029 1.238

END OF CHARGE BATTERY ON FINISHING RATE
CHARGE NUMBER 27
TOTAL BATTERY VOLTAGE 8.135
INDIVIDUAL CELL VOLTAGES SPECIFIC GRAVITY
CELL# 1 2.706 1.276
CELL# 5 2.704 1.279
CELL# 4 2.726 1.276

DISCHARGE NUMBER 28
DISCHARGE CURRENT 2.10 DURATION OF DISCHARGE 10.15 HR.
RECORDED CELL # 1
START OF DISCHARGE BATTERY PARAMETERS
TOTAL BATTERY VOLTAGE 6.793
INDIVIDUAL CELL VOLTAGES SPECIFIC GRAVITY
CELL# 1 2.263 1.276
CELL# 5 2.260 1.279
CELL# 4 2.287 1.276

END OF DISCHARGE BATTERY PARAMETERS
BATTERY CUTOFF VOLTAGE 4.70 REC. CELL CUTOFF VOLTAGE 1.74
CAPACITY OF BATTERY FOR THIS DISCHARGE 100.00 PERCENT
TOTAL BATTERY VOLTAGE 6.010
INDIVIDUAL CELL VOLTAGES SPECIFIC GRAVITY
CELL# 1 2.004 1.235
CELL# 5 1.990 1.236
CELL# 4 2.016 1.240

END OF CHARGE BATTERY ON FINISHING RATE
CHARGE NUMBER 28
TOTAL BATTERY VOLTAGE 7.956
INDIVIDUAL CELL VOLTAGES SPECIFIC GRAVITY
CELL# 1 2.653 1.282
CELL# 5 2.635 1.286
CELL# 4 2.665 1.292

DISCHARGE NUMBER 29
DISCHARGE CURRENT 3.40 DURATION OF DISCHARGE 0.0 HR.
RECORDED CELL # 1
START OF DISCHARGE BATTERY PARAMETERS
TOTAL BATTERY VOLTAGE 6.727
INDIVIDUAL CELL VOLTAGES SPECIFIC GRAVITY

CELL# 1 2.243 1.282
CELL# 3 2.230 1.286
CELL# 4 2.248 1.292

THE RECORDED CELL CONTROLLED THE DISCHARGE
END OF DISCHARGE BATTERY PARAMETERS
BATTERY CUTOFF VOLTAGE 0.0 REC. CELL CUTOFF VOLTAGE 0.0
CAPACITY OF BATTERY FOR THIS DISCHARGE 0.0 PERCENT
TOTAL BATTERY VOLTAGE 5.909
INDIVIDUAL CELL VOLTAGES SPECIFIC GRAVITY
CELL# 1 1.965 1.238
CELL# 3 1.951 1.241
CELL# 4 1.983 1.241

END OF CHARGE BATTERY ON FINISHING RATE
CHARGE NUMBER 29
TOTAL BATTERY VOLTAGE 8.006
INDIVIDUAL CELL VOLTAGES SPECIFIC GRAVITY
CELL# 1 2.669 1.282
CELL# 3 2.652 1.283
CELL# 4 2.682 1.290

DISCHARGE NUMBER 30
DISCHARGE CURRENT 3.00 DURATION OF DISCHARGE 5.53 HR.
RECORDED CELL # 1
START OF DISCHARGE BATTERY PARAMETERS
TOTAL BATTERY VOLTAGE 6.741
INDIVIDUAL CELL VOLTAGES SPECIFIC GRAVITY
CELL# 1 2.245 1.282
CELL# 3 2.239 1.283
CELL# 4 2.257 1.290

END OF DISCHARGE BATTERY PARAMETERS
BATTERY CUTOFF VOLTAGE 4.84 REC. CELL CUTOFF VOLTAGE 1.75
CAPACITY OF BATTERY FOR THIS DISCHARGE 86.98 PERCENT
TOTAL BATTERY VOLTAGE 6.059
INDIVIDUAL CELL VOLTAGES SPECIFIC GRAVITY
CELL# 1 2.018 1.236
CELL# 3 2.009 *****
CELL# 4 2.032 1.240

END OF CHARGE BATTERY ON FINISHING RATE
CHARGE NUMBER 30
TOTAL BATTERY VOLTAGE 8.035
INDIVIDUAL CELL VOLTAGES SPECIFIC GRAVITY
CELL# 1 2.671 1.232
CELL# 3 2.666 1.274
CELL# 4 2.696 1.286

DISCHARGE NUMBER 31
DISCHARGE CURRENT 3.00 DURATION OF DISCHARGE 6.48 HR.
RECORDED CELL # 1
START OF DISCHARGE BATTERY PARAMETERS
TOTAL BATTERY VOLTAGE 6.723
INDIVIDUAL CELL VOLTAGES SPECIFIC GRAVITY
CELL# 1 2.240 1.282
CELL# 3 2.229 1.274
CELL# 4 2.263 1.286

THE RECORDED CELL CONTROLLED THE DISCHARGE
END OF DISCHARGE BATTERY PARAMETERS
BATTERY CUTOFF VOLTAGE 4.56 REC. CELL CUTOFF VOLTAGE 1.44
CAPACITY OF BATTERY FOR THIS DISCHARGE 101.91 PERCENT
TOTAL BATTERY VOLTAGE 6.009
INDIVIDUAL CELL VOLTAGES SPECIFIC GRAVITY

CELL# 1 1.998 1.240
CELL# 5 1.995 1.240
CELL# 4 2.016 1.241

END OF CHARGE BATTERY ON FINISHING RATE
CHARGE NUMBER 31
TOTAL BATTERY VOLTAGE 8.037
INDIVIDUAL CELL VOLTAGES SPECIFIC GRAVITY
CELL# 1 2.674 1.280
CELL# 5 2.667 1.283
CELL# 4 2.695 1.289

DISCHARGE NUMBER 32
DISCHARGE CURRENT 3.90 DURATION OF DISCHARGE 4.78 HR.
RECORDED CELL # 5
START OF DISCHARGE BATTERY PARAMETERS
TOTAL BATTERY VOLTAGE 6.511
INDIVIDUAL CELL VOLTAGES SPECIFIC GRAVITY
CELL# 1 2.176 1.276
CELL# 5 2.156 1.278
CELL# 4 2.175 1.282

THE RECORDED CELL CONTROLLED THE DISCHARGE
END OF DISCHARGE BATTERY PARAMETERS
BATTERY CUTOFF VOLTAGE 4.69 REC. CELL CUTOFF VOLTAGE 1.10
CAPACITY OF BATTERY FOR THIS DISCHARGE 106.02 PERCENT
TOTAL BATTERY VOLTAGE 6.059
INDIVIDUAL CELL VOLTAGES SPECIFIC GRAVITY
CELL# 1 2.019 1.240
CELL# 5 2.006 1.240
CELL# 4 2.030 1.242

END OF CHARGE BATTERY ON FINISHING RATE
CHARGE NUMBER 32
TOTAL BATTERY VOLTAGE 8.092
INDIVIDUAL CELL VOLTAGES SPECIFIC GRAVITY
CELL# 1 2.685 1.276
CELL# 5 2.704 1.276
CELL# 4 2.703 1.277

DISCHARGE NUMBER 33
DISCHARGE CURRENT 3.00 DURATION OF DISCHARGE 6.65 HR.
RECORDED CELL # 1
START OF DISCHARGE BATTERY PARAMETERS
TOTAL BATTERY VOLTAGE 6.680
INDIVIDUAL CELL VOLTAGES SPECIFIC GRAVITY
CELL# 1 2.213 1.276
CELL# 5 2.704 1.276
CELL# 4 2.703 1.277

THE RECORDED CELL CONTROLLED THE DISCHARGE
END OF DISCHARGE BATTERY PARAMETERS
BATTERY CUTOFF VOLTAGE 4.60 REC. CELL CUTOFF VOLTAGE 1.15
CAPACITY OF BATTERY FOR THIS DISCHARGE 104.54 PERCENT
TOTAL BATTERY VOLTAGE 5.800
INDIVIDUAL CELL VOLTAGES SPECIFIC GRAVITY
CELL# 1 1.914 1.240
CELL# 5 1.929 1.240
CELL# 4 1.957 1.241

END OF CHARGE BATTERY ON FINISHING RATE
CHARGE NUMBER 33
TOTAL BATTERY VOLTAGE 7.953
INDIVIDUAL CELL VOLTAGES SPECIFIC GRAVITY
CELL# 1 2.649 1.292

CELL# 5 2.640 1.288
CELL# 4 2.664 1.293

DISCHARGE NUMBER 34
DISCHARGE CURRENT 3.00 DURATION OF DISCHARGE 6.30 HR.
RECORDED CELL # 5
START OF DISCHARGE BATTERY PARAMETERS
TOTAL BATTERY VOLTAGE 6.693
INDIVIDUAL CELL VOLTAGES SPECIFIC GRAVITY
CELL# 1 2.239 1.292
CELL# 5 2.234 1.288
CELL# 4 2.247 1.293

END OF DISCHARGE BATTERY PARAMETERS
BATTERY CUTOFF VOLTAGE 4.51 REC. CELL CUTOFF VOLTAGE 1.76
CAPACITY OF BATTERY FOR THIS DISCHARGE 99.03 PERCENT
TOTAL BATTERY VOLTAGE 6.146
INDIVIDUAL CELL VOLTAGES SPECIFIC GRAVITY
CELL# 1 2.043 1.240
CELL# 5 2.016 1.240
CELL# 4 2.057 1.240

END OF CHARGE BATTERY ON FINISHING RATE
CHARGE NUMBER 34
TOTAL BATTERY VOLTAGE 8.043
INDIVIDUAL CELL VOLTAGES SPECIFIC GRAVITY
CELL# 1 2.676 1.286
CELL# 5 2.671 1.280
CELL# 4 2.697 1.296

DISCHARGE NUMBER 35
DISCHARGE CURRENT 3.90 DURATION OF DISCHARGE 4.52 HR.
RECORDED CELL # 1
START OF DISCHARGE BATTERY PARAMETERS
TOTAL BATTERY VOLTAGE 6.635
INDIVIDUAL CELL VOLTAGES SPECIFIC GRAVITY
CELL# 1 2.214 1.286
CELL# 5 2.199 1.280
CELL# 4 2.222 1.296

THE RECORDED CELL CONTROLLED THE DISCHARGE
END OF DISCHARGE BATTERY PARAMETERS
BATTERY CUTOFF VOLTAGE 5.40 REC. CELL CUTOFF VOLTAGE 1.80
CAPACITY OF BATTERY FOR THIS DISCHARGE 100.11 PERCENT
TOTAL BATTERY VOLTAGE 6.060
INDIVIDUAL CELL VOLTAGES SPECIFIC GRAVITY
CELL# 1 2.015 1.245
CELL# 5 2.015 1.245
CELL# 4 2.027 1.242

END OF CHARGE BATTERY ON FINISHING RATE
CHARGE NUMBER 35
TOTAL BATTERY VOLTAGE 7.990
INDIVIDUAL CELL VOLTAGES SPECIFIC GRAVITY
CELL# 1 2.662 1.279
CELL#50 2.650 1.280
CELL#40 2.678 1.284

DISCHARGE NUMBER 36
DISCHARGE CURRENT 3.00 DURATION OF DISCHARGE 6.20 HR.
RECORDED CELL # 1
START OF DISCHARGE BATTERY PARAMETERS
TOTAL BATTERY VOLTAGE 6.743
INDIVIDUAL CELL VOLTAGES SPECIFIC GRAVITY
CELL# 1 2.272 1.279

CELL# 5 2.264 1.280
CELL# 4 2.207 1.284

THE RECORDED CELL CONTROLLED THE DISCHARGE
END OF DISCHARGE BATTERY PARAMETERS
BATTERY CUTOFF VOLTAGE 4.54 REC. CELL CUTOFF VOLTAGE 1.00
CAPACITY OF BATTERY FOR THIS DISCHARGE 97.46 PERCENT
TOTAL BATTERY VOLTAGE 5.981
INDIVIDUAL CELL VOLTAGES SPECIFIC GRAVITY
CELL# 1 1.976 1.241
CELL# 5 1.995 1.241
CELL# 4 2.002 1.243

END OF CHARGE BATTERY ON FINISHING RATE
CHARGE NUMBER 36
TOTAL BATTERY VOLTAGE 8.036
INDIVIDUAL CELL VOLTAGES SPECIFIC GRAVITY
CELL# 1 2.674 1.272
CELL# 5 2.669 1.282
CELL# 4 2.693 1.278

DISCHARGE NUMBER 37
DISCHARGE CURRENT 3.00 DURATION OF DISCHARGE 6.22 HR.
RECORDED CELL # 1
START OF DISCHARGE BATTERY PARAMETERS
TOTAL BATTERY VOLTAGE 6.540
INDIVIDUAL CELL VOLTAGES SPECIFIC GRAVITY
CELL# 1 2.184 1.262
CELL# 5 2.167 1.272
CELL# 4 2.189 1.268

THE RECORDED CELL CONTROLLED THE DISCHARGE
END OF DISCHARGE BATTERY PARAMETERS
BATTERY CUTOFF VOLTAGE 4.60 REC. CELL CUTOFF VOLTAGE 1.05
CAPACITY OF BATTERY FOR THIS DISCHARGE 97.71 PERCENT
TOTAL BATTERY VOLTAGE 6.219
INDIVIDUAL CELL VOLTAGES SPECIFIC GRAVITY
CELL# 1 2.067 1.240
CELL# 5 2.082 1.240
CELL# 4 2.074 1.241

END OF CHARGE BATTERY ON FINISHING RATE
CHARGE NUMBER 37
TOTAL BATTERY VOLTAGE 8.080
INDIVIDUAL CELL VOLTAGES SPECIFIC GRAVITY
CELL# 1 2.676 1.276
CELL# 5 2.682 1.250
CELL# 4 2.702 1.282

DISCHARGE NUMBER 38
DISCHARGE CURRENT 3.00 DURATION OF DISCHARGE 6.45 HR.
RECORDED CELL # 1
START OF DISCHARGE BATTERY PARAMETERS
TOTAL BATTERY VOLTAGE 6.520
INDIVIDUAL CELL VOLTAGES SPECIFIC GRAVITY
CELL# 1 2.171 1.266
CELL# 5 2.174 1.470
CELL# 4 2.175 1.272

THE RECORDED CELL CONTROLLED THE DISCHARGE
END OF DISCHARGE BATTERY PARAMETERS
BATTERY CUTOFF VOLTAGE 4.58 REC. CELL CUTOFF VOLTAGE 1.21
CAPACITY OF BATTERY FOR THIS DISCHARGE 101.39 PERCENT
TOTAL BATTERY VOLTAGE 6.214
INDIVIDUAL CELL VOLTAGES SPECIFIC GRAVITY

CELL# 1 2.065 1.250
CELL# 5 2.073 1.245
CELL# 4 2.076 1.250

END OF CHARGE BATTERY ON FINISHING RATE
CHARGE NUMBER 38
TOTAL BATTERY VOLTAGE 8.010
INDIVIDUAL CELL VOLTAGES SPECIFIC GRAVITY
CELL# 1 2.663 1.285
CELL# 5 2.665 1.279
CELL# 4 2.678 1.284

DISCHARGE NUMBER 39
DISCHARGE CURRENT 3.00 DURATION OF DISCHARGE 6.55 HR.
RECORDED CELL # 5
START OF DISCHARGE BATTERY PARAMETERS
TOTAL BATTERY VOLTAGE 6.484
INDIVIDUAL CELL VOLTAGES SPECIFIC GRAVITY
CELL# 1 2.169 1.282
CELL# 5 2.162 1.280
CELL# 4 2.177 1.282

END OF DISCHARGE BATTERY PARAMETERS
BATTERY CUTOFF VOLTAGE 4.62 REC. CELL CUTOFF VOLTAGE 1.90
CAPACITY OF BATTERY FOR THIS DISCHARGE 102.96 PERCENT
TOTAL BATTERY VOLTAGE 6.062
INDIVIDUAL CELL VOLTAGES SPECIFIC GRAVITY
CELL# 1 2.006 1.240
CELL# 5 2.162 1.280
CELL# 4 2.177 1.282

END OF CHARGE BATTERY ON FINISHING RATE
CHARGE NUMBER 39
TOTAL BATTERY VOLTAGE 8.019
INDIVIDUAL CELL VOLTAGES SPECIFIC GRAVITY
CELL# 1 2.664 1.281
CELL# 5 2.676 1.279
CELL# 4 2.679 1.278

DISCHARGE NUMBER 40
DISCHARGE CURRENT 3.00 DURATION OF DISCHARGE 6.57 HR.
RECORDED CELL # 1
START OF DISCHARGE BATTERY PARAMETERS
TOTAL BATTERY VOLTAGE 6.472
INDIVIDUAL CELL VOLTAGES SPECIFIC GRAVITY
CELL# 1 2.156 1.280
CELL# 5 2.160 1.277
CELL# 4 2.159 1.279

THE RECORDED CELL CONTROLLED THE DISCHARGE
END OF DISCHARGE BATTERY PARAMETERS
BATTERY CUTOFF VOLTAGE 4.55 REC. CELL CUTOFF VOLTAGE 1.17
CAPACITY OF BATTERY FOR THIS DISCHARGE 103.22 PERCENT
TOTAL BATTERY VOLTAGE 5.999
INDIVIDUAL CELL VOLTAGES SPECIFIC GRAVITY
CELL# 1 1.980 1.240
CELL# 5 2.013 1.242
CELL# 4 2.006 1.243

END OF CHARGE BATTERY ON FINISHING RATE
CHARGE NUMBER 40
TOTAL BATTERY VOLTAGE 6.010
INDIVIDUAL CELL VOLTAGES SPECIFIC GRAVITY
CELL# 1 2.660 1.282
CELL# 5 2.681 1.283

CELL# 4 2.666

1.282

DISCHARGE NUMBER 41
DISCHARGE CURRENT 3.00 DURATION OF DISCHARGE 6.28 HR.
RECORDED CELL # 4
START OF DISCHARGE BATTERY PARAMETERS
TOTAL BATTERY VOLTAGE 6.452
INDIVIDUAL CELL VOLTAGES SPECIFIC GRAVITY
CELL# 1 2.150 1.279
CELL# 5 2.155 1.279
CELL# 4 2.150 1.283

THE RECORDED CELL CONTROLLED THE DISCHARGE
END OF DISCHARGE BATTERY PARAMETERS
BATTERY CUTOFF VOLTAGE 4.70 REC. CELL CUTOFF VOLTAGE 1.05
CAPACITY OF BATTERY FOR THIS DISCHARGE 98.77 PERCENT
TOTAL BATTERY VOLTAGE 6.176
INDIVIDUAL CELL VOLTAGES SPECIFIC GRAVITY
CELL# 1 2.050 1.241
CELL# 5 2.067 1.246
CELL# 4 2.063 1.244

END OF CHARGE BATTERY ON FINISHING RATE
CHARGE NUMBER 41
TOTAL BATTERY VOLTAGE 8.005
INDIVIDUAL CELL VOLTAGES SPECIFIC GRAVITY
CELL# 1 2.667 1.282
CELL# 5 2.669 1.285
CELL# 4 2.668 1.280

DISCHARGE NUMBER 42
DISCHARGE CURRENT 3.00 DURATION OF DISCHARGE 6.27 HR.
RECORDED CELL # 1
START OF DISCHARGE BATTERY PARAMETERS
TOTAL BATTERY VOLTAGE 6.481
INDIVIDUAL CELL VOLTAGES SPECIFIC GRAVITY
CELL# 1 2.158 1.280
CELL# 5 2.163 1.284
CELL# 4 2.164 1.281

THE RECORDED CELL CONTROLLED THE DISCHARGE
END OF DISCHARGE BATTERY PARAMETERS
BATTERY CUTOFF VOLTAGE 4.68 REC. CELL CUTOFF VOLTAGE 1.05
CAPACITY OF BATTERY FOR THIS DISCHARGE 98.50 PERCENT
TOTAL BATTERY VOLTAGE 6.143
INDIVIDUAL CELL VOLTAGES SPECIFIC GRAVITY
CELL# 1 2.036 1.245
CELL# 5 2.058 1.246
CELL# 4 2.053 1.246

END OF CHARGE BATTERY ON FINISHING RATE
CHARGE NUMBER 42
TOTAL BATTERY VOLTAGE 8.007
INDIVIDUAL CELL VOLTAGES SPECIFIC GRAVITY
CELL# 1 2.669 1.283
CELL# 5 2.675 1.282
CELL# 4 2.669 1.280

DISCHARGE NUMBER 43
DISCHARGE CURRENT 3.00 DURATION OF DISCHARGE 6.32 HR.
RECORDED CELL # 1
START OF DISCHARGE BATTERY PARAMETERS
TOTAL BATTERY VOLTAGE 6.487
INDIVIDUAL CELL VOLTAGES SPECIFIC GRAVITY
CELL# 1 2.157 1.282

CELL# 5 2.162 1.287
CELL# 4 2.166 1.292

THE RECORDED CELL CONTROLLED THE DISCHARGE
END OF DISCHARGE BATTERY PARAMETERS
BATTERY CUTOFF VOLTAGE 4.73 REC. CELL CUTOFF VOLTAGE 1.17
CAPACITY OF BATTERY FOR THIS DISCHARGE 99.29 PERCENT
TOTAL BATTERY VOLTAGE 6.234
INDIVIDUAL CELL VOLTAGES SPECIFIC GRAVITY
CELL# 1 2.063 1.240
CELL# 5 2.074 1.245
CELL# 4 2.073 1.246

END OF CHARGE BATTERY ON FINISHING RATE
CHARGE NUMBER 43
TOTAL BATTERY VOLTAGE 7.980
INDIVIDUAL CELL VOLTAGES SPECIFIC GRAVITY
CELL# 1 2.654 1.279
CELL# 5 2.669 1.284
CELL# 4 2.657 1.284

DISCHARGE NUMBER 44
DISCHARGE CURRENT 3.00 DURATION OF DISCHARGE 6.35 HR.
RECORDED CELL # 4
START OF DISCHARGE BATTERY PARAMETERS
TOTAL BATTERY VOLTAGE 6.632
INDIVIDUAL CELL VOLTAGES SPECIFIC GRAVITY
CELL# 1 2.208 1.279
CELL# 5 2.208 1.284
CELL# 4 2.216 1.284

END OF DISCHARGE BATTERY PARAMETERS
BATTERY CUTOFF VOLTAGE 4.68 REC. CELL CUTOFF VOLTAGE 1.89
CAPACITY OF BATTERY FOR THIS DISCHARGE 99.82 PERCENT
TOTAL BATTERY VOLTAGE 6.072
INDIVIDUAL CELL VOLTAGES SPECIFIC GRAVITY
CELL# 1 2.009 1.245
CELL# 5 2.030 1.250
CELL# 4 2.029 1.246

END OF CHARGE BATTERY ON FINISHING RATE
CHARGE NUMBER 44
TOTAL BATTERY VOLTAGE 7.989
INDIVIDUAL CELL VOLTAGES SPECIFIC GRAVITY
CELL# 1 2.663 1.285
CELL# 5 2.667 1.280
CELL# 4 2.659 1.277

DISCHARGE NUMBER 45
DISCHARGE CURRENT 3.00 DURATION OF DISCHARGE 6.25 HR.
RECORDED CELL # 4
START OF DISCHARGE BATTERY PARAMETERS
TOTAL BATTERY VOLTAGE 6.524
INDIVIDUAL CELL VOLTAGES SPECIFIC GRAVITY
CELL# 1 2.173 1.284
CELL# 5 2.716 1.283
CELL# 4 2.177 1.284

END OF DISCHARGE BATTERY PARAMETERS
BATTERY CUTOFF VOLTAGE 4.56 REC. CELL CUTOFF VOLTAGE 1.83
CAPACITY OF BATTERY FOR THIS DISCHARGE 98.25 PERCENT
TOTAL BATTERY VOLTAGE 6.090
INDIVIDUAL CELL VOLTAGES SPECIFIC GRAVITY
CELL# 1 2.015 1.240
CELL# 5 2.039 1.246

CELL# 4 2.036

1.251

END OF CHARGE BATTERY ON FINISHING RATE
CHARGE NUMBER 45
TOTAL BATTERY VOLTAGE 8.001
INDIVIDUAL CELL VOLTAGES SPECIFIC GRAVITY
CELL# 1 2.666 1.284
CELL# 5 2.678 1.280
CELL# 4 2.657 1.259

DISCHARGE NUMBER 46
DISCHARGE CURRENT 3.00 DURATION OF DISCHARGE 6.28 HR.
RECORDED CELL # 1
START OF DISCHARGE BATTERY PARAMETERS
TOTAL BATTERY VOLTAGE 6.563
INDIVIDUAL CELL VOLTAGES SPECIFIC GRAVITY
CELL# 1 2.187 1.282
CELL# 5 2.190 1.283
CELL# 4 2.185 1.280

THE RECORDED CELL CONTROLLED THE DISCHARGE
END OF DISCHARGE BATTERY PARAMETERS
BATTERY CUTOFF VOLTAGE 4.60 REC. CELL CUTOFF VOLTAGE 1.05
CAPACITY OF BATTERY FOR THIS DISCHARGE 98.77 PERCENT
TOTAL BATTERY VOLTAGE 5.903
INDIVIDUAL CELL VOLTAGES SPECIFIC GRAVITY
CELL# 1 1.939 1.245
CELL# 5 1.992 1.250
CELL# 4 1.972 1.240

END OF CHARGE BATTERY ON FINISHING RATE
CHARGE NUMBER 46
TOTAL BATTERY VOLTAGE 7.939
INDIVIDUAL CELL VOLTAGES SPECIFIC GRAVITY
CELL# 1 2.649 1.282
CELL# 5 2.655 1.282
CELL# 4 2.635 1.277

DISCHARGE NUMBER 47
DISCHARGE CURRENT 3.00 DURATION OF DISCHARGE 6.12 HR.
RECORDED CELL # 4
START OF DISCHARGE BATTERY PARAMETERS
TOTAL BATTERY VOLTAGE 3.727
INDIVIDUAL CELL VOLTAGES SPECIFIC GRAVITY
CELL# 1 2.250 1.282
CELL# 5 2.258 1.282
CELL# 4 2.250 1.277

END OF DISCHARGE BATTERY PARAMETERS
BATTERY CUTOFF VOLTAGE 4.63 REC. CELL CUTOFF VOLTAGE 1.81
CAPACITY OF BATTERY FOR THIS DISCHARGE 96.14 PERCENT
TOTAL BATTERY VOLTAGE 6.192
INDIVIDUAL CELL VOLTAGES SPECIFIC GRAVITY
CELL# 1 2.056 1.241
CELL# 5 2.071 1.251
CELL# 4 2.063 1.244

END OF CHARGE BATTERY ON FINISHING RATE
CHARGE NUMBER 47
TOTAL BATTERY VOLTAGE 8.000
INDIVIDUAL CELL VOLTAGES SPECIFIC GRAVITY
CELL# 1 2.661 1.273
CELL# 5 2.674 1.275
CELL# 4 2.648 1.266

DISCHARGE NUMBER 48
 DISCHARGE CURRENT 3.00 DURATION OF DISCHARGE 6.52 HR.
 RECORDED CELL # 1
 START OF DISCHARGE BATTERY PARAMETERS
 TOTAL BATTERY VOLTAGE 6.622
 INDIVIDUAL CELL VOLTAGES SPECIFIC GRAVITY
 CELL# 1 2.208 1.273
 CELL# 5 2.211 1.275
 CELL# 4 2.203 1.266

THE RECORDED CELL CONTROLLED THE DISCHARGE
 END OF DISCHARGE BATTERY PARAMETERS
 BATTERY CUTOFF VOLTAGE 4.65 REC. CELL CUTOFF VOLTAGE 1.05
 CAPACITY OF BATTERY FOR THIS DISCHARGE 102.43 PERCENT
 TOTAL BATTERY VOLTAGE 5.988
 INDIVIDUAL CELL VOLTAGES SPECIFIC GRAVITY
 CELL# 1 1.978 1.244
 CELL# 5 2.011 1.248
 CELL# 4 1.996 1.243

END OF CHARGE BATTERY ON FINISHING RATE
 CHARGE NUMBER 48
 TOTAL BATTERY VOLTAGE 7.955
 INDIVIDUAL CELL VOLTAGES SPECIFIC GRAVITY
 CELL# 1 2.656 1.280
 CELL# 5 2.659 1.281
 CELL# 4 2.639 1.278

DISCHARGE NUMBER 49
 DISCHARGE CURRENT 3.00 DURATION OF DISCHARGE 6.15 HR.
 RECORDED CELL # 5
 START OF DISCHARGE BATTERY PARAMETERS
 TOTAL BATTERY VOLTAGE 6.860
 INDIVIDUAL CELL VOLTAGES SPECIFIC GRAVITY
 CELL# 1 2.295 1.280
 CELL# 5 2.305 1.281
 CELL# 4 2.294 1.278

END OF DISCHARGE BATTERY PARAMETERS
 BATTERY CUTOFF VOLTAGE 4.52 REC. CELL CUTOFF VOLTAGE 1.82
 CAPACITY OF BATTERY FOR THIS DISCHARGE 96.68 PERCENT
 TOTAL BATTERY VOLTAGE 6.082
 INDIVIDUAL CELL VOLTAGES SPECIFIC GRAVITY
 CELL# 1 2.013 1.255
 CELL# 5 2.041 1.255
 CELL# 4 2.028 1.242

END OF CHARGE BATTERY ON FINISHING RATE
 CHARGE NUMBER 49
 TOTAL BATTERY VOLTAGE 8.005
 INDIVIDUAL CELL VOLTAGES SPECIFIC GRAVITY
 CELL# 1 2.671 1.228
 CELL# 5 2.677 1.227
 CELL# 4 2.657 1.270

DISCHARGE NUMBER 50
 DISCHARGE CURRENT 3.00 DURATION OF DISCHARGE 6.15 HR.
 RECORDED CELL # 1
 START OF DISCHARGE BATTERY PARAMETERS
 TOTAL BATTERY VOLTAGE 6.756
 INDIVIDUAL CELL VOLTAGES SPECIFIC GRAVITY
 CELL# 1 2.256 1.270
 CELL# 5 2.266 1.270
 CELL# 4 2.256 1.270

THE RECORDED CELL CONTROLLED THE DISCHARGE
END OF DISCHARGE BATTERY PARAMETERS
BATTERY CUTOFF VOLTAGE 4.78 REC. CELL CUTOFF VOLTAGE 1.16
CAPACITY OF BATTERY FOR THIS DISCHARGE 96.68 PERCENT
TOTAL BATTERY VOLTAGE 6.207
INDIVIDUAL CELL VOLTAGES SPECIFIC GRAVITY
CELL# 1 2.061 1.246
CELL# 5 2.076 1.250
CELL# 4 2.068 1.243

END OF CHARGE BATTERY ON FINISHING RATE
CHARGE NUMBER 50
TOTAL BATTERY VOLTAGE 7.855
INDIVIDUAL CELL VOLTAGES SPECIFIC GRAVITY
CELL# 1 2.402 1.283
CELL# 5 2.739 1.282
CELL# 4 2.714 1.274

DISCHARGE NUMBER 51
DISCHARGE CURRENT 3.00 DURATION OF DISCHARGE 7.03 HR.
RECORDED CELL # 1
START OF DISCHARGE BATTERY PARAMETERS
TOTAL BATTERY VOLTAGE 6.852
INDIVIDUAL CELL VOLTAGES SPECIFIC GRAVITY
CELL# 1 2.184 1.283
CELL# 5 2.343 1.282
CELL# 4 2.345 1.274

THE RECORDED CELL CONTROLLED THE DISCHARGE
END OF DISCHARGE BATTERY PARAMETERS
BATTERY CUTOFF VOLTAGE 4.73 REC. CELL CUTOFF VOLTAGE 1.14
CAPACITY OF BATTERY FOR THIS DISCHARGE 110.56 PERCENT
TOTAL BATTERY VOLTAGE 6.198
INDIVIDUAL CELL VOLTAGES SPECIFIC GRAVITY
CELL# 1 2.059 1.240
CELL# 5 2.073 1.248
CELL# 4 2.064 1.241

END OF CHARGE BATTERY ON FINISHING RATE
CHARGE NUMBER 51
TOTAL BATTERY VOLTAGE 8.054
INDIVIDUAL CELL VOLTAGES SPECIFIC GRAVITY
CELL# 1 2.676 1.284
CELL# 5 2.703 1.288
CELL# 4 2.674 1.272

DISCHARGE NUMBER 52
DISCHARGE CURRENT 3.00 DURATION OF DISCHARGE 6.88 HR.
RECORDED CELL # 4
START OF DISCHARGE BATTERY PARAMETERS
TOTAL BATTERY VOLTAGE 6.847
INDIVIDUAL CELL VOLTAGES SPECIFIC GRAVITY
CELL# 1 2.267 1.284
CELL# 5 2.296 1.288
CELL# 4 2.287 1.272

END OF DISCHARGE BATTERY PARAMETERS
BATTERY CUTOFF VOLTAGE 4.70 REC. CELL CUTOFF VOLTAGE 1.87
CAPACITY OF BATTERY FOR THIS DISCHARGE 108.20 PERCENT
TOTAL BATTERY VOLTAGE 5.838
INDIVIDUAL CELL VOLTAGES SPECIFIC GRAVITY
CELL# 1 1.887 1.246
CELL# 5 1.978 1.253
CELL# 4 1.954 1.247

END OF CHARGE BATTERY ON FINISHING RATE
CHARGE NUMBER 52
TOTAL BATTERY VOLTAGE 2.982
INDIVIDUAL CELL VOLTAGES SPECIFIC GRAVITY
CELL# 1 2.658 1.274
CELL# 5 2.672 1.282
CELL# 4 2.651 1.272

DISCHARGE NUMBER 53
DISCHARGE CURRENT 3.00 DURATION OF DISCHARGE 6.35 HR.
RECORDED CELL # 1
START OF DISCHARGE BATTERY PARAMETERS
TOTAL BATTERY VOLTAGE 6.805
INDIVIDUAL CELL VOLTAGES SPECIFIC GRAVITY
CELL# 1 2.258 1.274
CELL# 5 2.285 1.282
CELL# 4 2.273 1.272

THE RECORDED CELL CONTROLLED THE DISCHARGE
END OF DISCHARGE BATTERY PARAMETERS
BATTERY CUTOFF VOLTAGE 4.80 REC. CELL CUTOFF VOLTAGE 1.12
CAPACITY OF BATTERY FOR THIS DISCHARGE 99.82 PERCENT
TOTAL BATTERY VOLTAGE 5.961
INDIVIDUAL CELL VOLTAGES SPECIFIC GRAVITY
CELL# 1 1.957 1.243
CELL# 5 2.008 1.250
CELL# 4 1.995 1.241

END OF CHARGE BATTERY ON FINISHING RATE
CHARGE NUMBER 53
TOTAL BATTERY VOLTAGE 7.949
INDIVIDUAL CELL VOLTAGES SPECIFIC GRAVITY
CELL# 1 2.618 1.276
CELL# 5 2.680 1.276
CELL# 4 2.651 1.269

DISCHARGE NUMBER 54
DISCHARGE CURRENT 3.00 DURATION OF DISCHARGE 6.38 HR.
RECORDED CELL # 5
START OF DISCHARGE BATTERY PARAMETERS
TOTAL BATTERY VOLTAGE 6.797
INDIVIDUAL CELL VOLTAGES SPECIFIC GRAVITY
CELL# 1 2.248 1.276
CELL# 5 2.290 1.276
CELL# 4 2.279 1.269

END OF DISCHARGE BATTERY PARAMETERS
BATTERY CUTOFF VOLTAGE 4.80 REC. CELL CUTOFF VOLTAGE 1.91
CAPACITY OF BATTERY FOR THIS DISCHARGE 95.62 PERCENT
TOTAL BATTERY VOLTAGE 6.215
INDIVIDUAL CELL VOLTAGES SPECIFIC GRAVITY
CELL# 1 2.060 1.243
CELL# 5 2.081 1.255
CELL# 4 2.071 1.240

END OF CHARGE BATTERY ON FINISHING RATE
CHARGE NUMBER 54
TOTAL BATTERY VOLTAGE 7.916
INDIVIDUAL CELL VOLTAGES SPECIFIC GRAVITY
CELL# 1 2.533 1.276
CELL# 5 2.708 1.285
CELL# 4 2.675 1.272

DISCHARGE NUMBER 55

DISCHARGE CURRENT 3.00 DURATION OF DISCHARGE 6.12 HR.
RECORDED CELL # 1
START OF DISCHARGE BATTERY PARAMETERS
TOTAL BATTERY VOLTAGE 6.637
INDIVIDUAL CELL VOLTAGES SPECIFIC GRAVITY
CELL# 1 2.205 1.276
CELL# 5 2.221 1.285
CELL# 4 2.214 1.272

THE RECORDED CELL CONTROLLED THE DISCHARGE
END OF DISCHARGE BATTERY PARAMETERS
BATTERY CUTOFF VOLTAGE 4.65 REC. CELL CUTOFF VOLTAGE 1.05
CAPACITY OF BATTERY FOR THIS DISCHARGE 96.14 PERCENT
TOTAL BATTERY VOLTAGE 6.228
INDIVIDUAL CELL VOLTAGES SPECIFIC GRAVITY
CELL# 1 2.060 1.241
CELL# 5 2.089 1.251
CELL# 4 2.079 1.241

END OF CHARGE BATTERY ON FINISHING RATE
CHARGE NUMBER 55
TOTAL BATTERY VOLTAGE 7.851
INDIVIDUAL CELL VOLTAGES SPECIFIC GRAVITY
CELL# 1 2.502 1.279
CELL# 5 2.691 1.280
CELL# 4 2.658 1.270

DISCHARGE NUMBER 56
DISCHARGE CURRENT 3.00 DURATION OF DISCHARGE 6.03 HR.
RECORDED CELL # 1
START OF DISCHARGE BATTERY PARAMETERS
TOTAL BATTERY VOLTAGE 6.738
INDIVIDUAL CELL VOLTAGES SPECIFIC GRAVITY
CELL# 1 2.248 1.279
CELL# 5 2.251 1.290
CELL# 4 2.239 1.270

THE RECORDED CELL CONTROLLED THE DISCHARGE
END OF DISCHARGE BATTERY PARAMETERS
BATTERY CUTOFF VOLTAGE 4.65 REC. CELL CUTOFF VOLTAGE 0.90
CAPACITY OF BATTERY FOR THIS DISCHARGE 94.84 PERCENT
TOTAL BATTERY VOLTAGE 6.116
INDIVIDUAL CELL VOLTAGES SPECIFIC GRAVITY
CELL# 1 2.011 1.245
CELL# 5 2.058 1.255
CELL# 4 2.047 1.247

END OF CHARGE BATTERY ON FINISHING RATE
CHARGE NUMBER 56
TOTAL BATTERY VOLTAGE 7.926
INDIVIDUAL CELL VOLTAGES SPECIFIC GRAVITY
CELL# 1 2.495 1.275
CELL# 5 2.734 1.284
CELL# 4 2.697 1.277

DISCHARGE NUMBER 57
DISCHARGE CURRENT 3.00 DURATION OF DISCHARGE 5.77 HR.
RECORDED CELL # 4
START OF DISCHARGE BATTERY PARAMETERS
TOTAL BATTERY VOLTAGE 6.732
INDIVIDUAL CELL VOLTAGES SPECIFIC GRAVITY
CELL# 1 2.214 1.275
CELL# 5 2.262 1.284
CELL# 4 2.252 1.277

END OF DISCHARGE BATTERY PARAMETERS
BATTERY CUTOFF VOLTAGE 4.70 REC. CELL CUTOFF VOLTAGE 1.95
CAPACITY OF BATTERY FOR THIS DISCHARGE 90.64 PERCENT
TOTAL BATTERY VOLTAGE 6.148
INDIVIDUAL CELL VOLTAGES SPECIFIC GRAVITY
CELL# 1 2.013 1.246
CELL# 5 2.071 1.260
CELL# 4 2.061 1.251

END OF CHARGE BATTERY ON FINISHING RATE
CHARGE NUMBER 57
TOTAL BATTERY VOLTAGE 7.958
INDIVIDUAL CELL VOLTAGES SPECIFIC GRAVITY
CELL# 1 2.531 1.276
CELL# 5 2.731 1.290
CELL# 4 2.697 1.274

DISCHARGE NUMBER 58
DISCHARGE CURRENT 3.00 DURATION OF DISCHARGE 5.43 HR.
RECORDED CELL # 1
START OF DISCHARGE BATTERY PARAMETERS
TOTAL BATTERY VOLTAGE 6.921
INDIVIDUAL CELL VOLTAGES SPECIFIC GRAVITY
CELL# 1 2.225 1.276
CELL# 5 2.395 1.290
CELL# 4 2.385 1.274

THE RECORDED CELL CONTROLLED THE DISCHARGE
END OF DISCHARGE BATTERY PARAMETERS
BATTERY CUTOFF VOLTAGE 4.65 REC. CELL CUTOFF VOLTAGE 0.90
CAPACITY OF BATTERY FOR THIS DISCHARGE 85.41 PERCENT
TOTAL BATTERY VOLTAGE 6.254
INDIVIDUAL CELL VOLTAGES SPECIFIC GRAVITY
CELL# 1 2.061 1.240
CELL# 5 2.101 1.260
CELL# 4 2.092 1.245

END OF CHARGE BATTERY ON FINISHING RATE
CHARGE NUMBER 58
TOTAL BATTERY VOLTAGE 7.952
INDIVIDUAL CELL VOLTAGES SPECIFIC GRAVITY
CELL# 1 2.543 1.282
CELL# 5 2.721 1.283
CELL# 4 2.689 1.272

DISCHARGE NUMBER 59
DISCHARGE CURRENT 3.00 DURATION OF DISCHARGE 5.25 HR.
RECORDED CELL # 1
START OF DISCHARGE BATTERY PARAMETERS
TOTAL BATTERY VOLTAGE 6.740
INDIVIDUAL CELL VOLTAGES SPECIFIC GRAVITY
CELL# 1 2.235 1.282
CELL# 5 2.350 1.283
CELL# 4 2.340 1.272

THE RECORDED CELL CONTROLLED THE DISCHARGE
END OF DISCHARGE BATTERY PARAMETERS
BATTERY CUTOFF VOLTAGE 4.50 REC. CELL CUTOFF VOLTAGE 0.68
CAPACITY OF BATTERY FOR THIS DISCHARGE 82.53 PERCENT
TOTAL BATTERY VOLTAGE 6.262
INDIVIDUAL CELL VOLTAGES SPECIFIC GRAVITY
CELL# 1 2.064 1.241
CELL# 5 2.102 1.260
CELL# 4 2.094 1.248

END OF CHARGE BATTERY ON FINISHING RATE
CHARGE NUMBER 59
TOTAL BATTERY VOLTAGE 7.850
INDIVIDUAL CELL VOLTAGES SPECIFIC GRAVITY
CELL# 1 2.503 1.274
CELL# 5 2.735 1.286
CELL# 4 2.616 1.278

DISCHARGE NUMBER 60
DISCHARGE CURRENT 3.00 DURATION OF DISCHARGE 5.68 HR.
RECORDED CELL # 1
START OF DISCHARGE BATTERY PARAMETERS
TOTAL BATTERY VOLTAGE 6.781
INDIVIDUAL CELL VOLTAGES SPECIFIC GRAVITY
CELL# 1 2.217 1.274
CELL# 5 2.315 1.286
CELL# 4 2.279 1.278

THE RECORDED CELL CONTROLLED THE DISCHARGE
END OF DISCHARGE BATTERY PARAMETERS
BATTERY CUTOFF VOLTAGE 4.59 REC. CELL CUTOFF VOLTAGE 0.82
CAPACITY OF BATTERY FOR THIS DISCHARGE 89.34 PERCENT
TOTAL BATTERY VOLTAGE 6.272
INDIVIDUAL CELL VOLTAGES SPECIFIC GRAVITY
CELL# 1 2.070 1.246
CELL# 5 2.108 1.259
CELL# 4 2.096 1.246

END OF CHARGE BATTERY ON FINISHING RATE
CHARGE NUMBER 60
TOTAL BATTERY VOLTAGE 7.983
INDIVIDUAL CELL VOLTAGES SPECIFIC GRAVITY
CELL# 1 2.597 1.286
CELL# 5 2.722 1.292
CELL# 4 2.663 1.282

APPENDIX E

CYCLE HISTORY OF PBCA # 2

DISCHARGE NUMBER 1
 DISCHARGE CURRENT 4.50 DURATION OF DISCHARGE 2.98 HR.
 RECORDED CELL # 3
 START OF DISCHARGE BATTERY PARAMETERS
 TOTAL BATTERY VOLTAGE 6.697
 INDIVIDUAL CELL VOLTAGES SPECIFIC GRAVITY
 CELL# 1 2.236 1.274
 CELL# 2 2.227 1.276
 CELL# 3 2.400 1.274

THE RECORDED CELL CONTROLLED THE DISCHARGE
 END OF DISCHARGE BATTERY PARAMETERS
 BATTERY CUTOFF VOLTAGE 4.49 REC. CELL CUTOFF VOLTAGE 1.52
 CAPACITY OF BATTERY FOR THIS DISCHARGE 80.55 PERCENT
 TOTAL BATTERY VOLTAGE 5.750
 INDIVIDUAL CELL VOLTAGES SPECIFIC GRAVITY
 CELL# 1 1.193 1.256
 CELL# 2 1.910 1.254
 CELL# 3 1.897 1.250

END OF CHARGE BATTERY ON FINISHING RATE
 CHARGE NUMBER 1
 TOTAL BATTERY VOLTAGE 8.068
 INDIVIDUAL CELL VOLTAGES SPECIFIC GRAVITY
 CELL# 1 2.697 1.271
 CELL# 2 2.684 1.268
 CELL# 3 2.687 1.268

DISCHARGE NUMBER 2
 DISCHARGE CURRENT 3.00 DURATION OF DISCHARGE 4.78 HR.
 RECORDED CELL # 2
 START OF DISCHARGE BATTERY PARAMETERS
 TOTAL BATTERY VOLTAGE 6.580
 INDIVIDUAL CELL VOLTAGES SPECIFIC GRAVITY
 CELL# 1 2.195 1.271
 CELL# 2 2.195 1.271
 CELL# 3 2.198 1.268

THE RECORDED CELL CONTROLLED THE DISCHARGE
 END OF DISCHARGE BATTERY PARAMETERS
 BATTERY CUTOFF VOLTAGE 4.49 REC. CELL CUTOFF VOLTAGE 1.00
 CAPACITY OF BATTERY FOR THIS DISCHARGE 83.29 PERCENT
 TOTAL BATTERY VOLTAGE 5.248
 INDIVIDUAL CELL VOLTAGES SPECIFIC GRAVITY
 CELL# 1 2.081 1.243
 CELL# 2 2.083 1.246
 CELL# 3 2.082 1.241

END OF CHARGE BATTERY ON FINISHING RATE
 CHARGE NUMBER 2
 TOTAL BATTERY VOLTAGE 8.045
 INDIVIDUAL CELL VOLTAGES SPECIFIC GRAVITY
 CELL# 1 2.685 1.265
 CELL# 2 2.674 1.270
 CELL# 3 2.674 1.265

DISCHARGE NUMBER 3
 DISCHARGE CURRENT 4.50 DURATION OF DISCHARGE 2.98 HR.

RECORDED CELL # 1
START OF DISCHARGE BATTERY PARAMETERS
TOTAL BATTERY VOLTAGE 6.485
INDIVIDUAL CELL VOLTAGES SPECIFIC GRAVITY
CELL# 1 2.162 1.268
CELL# 2 2.163 1.270
CELL# 3 2.160 1.269

END OF DISCHARGE BATTERY PARAMETERS
BATTERY CUTOFF VOLTAGE 4.60 REC. CELL CUTOFF VOLTAGE 1.70
CAPACITY OF BATTERY FOR THIS DISCHARGE 80.55 PERCENT
TOTAL BATTERY VOLTAGE 5.768
INDIVIDUAL CELL VOLTAGES SPECIFIC GRAVITY
CELL# 1 1.932 1.245
CELL# 2 1.882 1.250
CELL# 3 1.915 1.247

END OF CHARGE BATTERY ON FINISHING RATE
CHARGE NUMBER 3
TOTAL BATTERY VOLTAGE 7.983
INDIVIDUAL CELL VOLTAGES SPECIFIC GRAVITY
CELL# 1 2.667 1.272
CELL# 2 2.654 1.272
CELL# 3 2.660 1.269

DISCHARGE NUMBER 4
DISCHARGE CURRENT 3.00 DURATION OF DISCHARGE 4.80 HR.
RECORDED CELL # 3
START OF DISCHARGE BATTERY PARAMETERS
TOTAL BATTERY VOLTAGE 6.670
INDIVIDUAL CELL VOLTAGES SPECIFIC GRAVITY
CELL# 1 2.227 1.272
CELL# 2 2.220 1.272
CELL# 3 2.230 1.269

END OF DISCHARGE BATTERY PARAMETERS
BATTERY CUTOFF VOLTAGE 4.70 REC. CELL CUTOFF VOLTAGE 1.74
CAPACITY OF BATTERY FOR THIS DISCHARGE 83.58 PERCENT
TOTAL BATTERY VOLTAGE 6.219
INDIVIDUAL CELL VOLTAGES SPECIFIC GRAVITY
CELL# 1 2.075 1.243
CELL# 2 2.071 1.244
CELL# 3 2.072 1.241

END OF CHARGE BATTERY ON FINISHING RATE
CHARGE NUMBER 4
TOTAL BATTERY VOLTAGE 7.993
INDIVIDUAL CELL VOLTAGES SPECIFIC GRAVITY
CELL# 1 2.663 1.274
CELL# 2 2.262 1.276
CELL# 3 2.669 1.276

DISCHARGE NUMBER 5
DISCHARGE CURRENT 4.50 DURATION OF DISCHARGE 3.05 HR.
RECORDED CELL # 2
START OF DISCHARGE BATTERY PARAMETERS
TOTAL BATTERY VOLTAGE 6.486
INDIVIDUAL CELL VOLTAGES SPECIFIC GRAVITY
CELL# 1 2.162 1.274
CELL# 2 2.163 1.276
CELL# 3 2.162 1.276

THE RECORDED CELL CONTROLLED THE DISCHARGE
END OF DISCHARGE BATTERY PARAMETERS
BATTERY CUTOFF VOLTAGE 4.70 REC. CELL CUTOFF VOLTAGE 1.35

CAPACITY OF BATTERY FOR THIS DISCHARGE 82.36 PERCENT
TOTAL BATTERY VOLTAGE 5.899
INDIVIDUAL CELL VOLTAGES SPECIFIC GRAVITY
CELL# 1 1.961 1.247
CELL# 2 1.953 1.251
CELL# 3 1.960 1.249

END OF CHARGE BATTERY ON FINISHING RATE
CHARGE NUMBER 5
TOTAL BATTERY VOLTAGE 7.957
INDIVIDUAL CELL VOLTAGES SPECIFIC GRAVITY
CELL# 1 2.658 1.273
CELL# 2 2.647 1.274
CELL# 3 2.650 1.271

DISCHARGE NUMBER 6
DISCHARGE CURRENT 2.50 DURATION OF DISCHARGE 6.50 HR.
RECORDED CELL # 1
START OF DISCHARGE BATTERY PARAMETERS
TOTAL BATTERY VOLTAGE 6.676
INDIVIDUAL CELL VOLTAGES SPECIFIC GRAVITY
CELL# 1 2.228 1.273
CELL# 2 2.226 1.274
CELL# 3 2.230 1.271

END OF DISCHARGE BATTERY PARAMETERS
BATTERY CUTOFF VOLTAGE 3.30 REC. CELL CUTOFF VOLTAGE 1.33
CAPACITY OF BATTERY FOR THIS DISCHARGE 92.92 PERCENT
TOTAL BATTERY VOLTAGE 6.233
INDIVIDUAL CELL VOLTAGES SPECIFIC GRAVITY
CELL# 1 2.078 1.241
CELL# 2 2.077 1.244
CELL# 3 2.077 1.241

END OF CHARGE BATTERY ON FINISHING RATE
CHARGE NUMBER 6
TOTAL BATTERY VOLTAGE 8.018
INDIVIDUAL CELL VOLTAGES SPECIFIC GRAVITY
CELL# 1 2.678 1.272
CELL# 2 2.669 1.272
CELL# 3 2.671 1.272

DISCHARGE NUMBER 7
DISCHARGE CURRENT 2.50 DURATION OF DISCHARGE 7.05 HR.
RECORDED CELL # 2
START OF DISCHARGE BATTERY PARAMETERS
TOTAL BATTERY VOLTAGE 6.650
INDIVIDUAL CELL VOLTAGES SPECIFIC GRAVITY
CELL# 1 2.237 1.272
CELL# 2 2.233 1.272
CELL# 3 2.235 1.272

THE RECORDED CELL CONTROLLED THE DISCHARGE
END OF DISCHARGE BATTERY PARAMETERS
BATTERY CUTOFF VOLTAGE 3.78 REC. CELL CUTOFF VOLTAGE 1.10
CAPACITY OF BATTERY FOR THIS DISCHARGE 100.78 PERCENT
TOTAL BATTERY VOLTAGE 5.950
INDIVIDUAL CELL VOLTAGES SPECIFIC GRAVITY
CELL# 1 1.987 1.237
CELL# 2 1.979 1.242
CELL# 3 1.987 1.241

END OF CHARGE BATTERY ON FINISHING RATE
CHARGE NUMBER 7
TOTAL BATTERY VOLTAGE 8.094

INDIVIDUAL CELL VOLTAGES SPECIFIC GRAVITY
CELL# 1 2.704 1.268
CELL# 2 2.631 1.275
CELL# 3 2.694 1.270

DISCHARGE NUMBER 8 DURATION OF DISCHARGE 6.30 HR.
DISCHARGE CURRENT 2.30
RECORDED CELL # 3
START OF DISCHARGE BATTERY PARAMETERS
TOTAL BATTERY VOLTAGE 6.660
INDIVIDUAL CELL VOLTAGES SPECIFIC GRAVITY
CELL# 1 2.226 1.268
CELL# 2 2.225 1.275
CELL# 3 2.229 1.270

END OF DISCHARGE BATTERY PARAMETERS
BATTERY CUTOFF VOLTAGE 3.95 REC. CELL CUTOFF VOLTAGE 1.57
CAPACITY OF BATTERY FOR THIS DISCHARGE 101.81 PERCENT
TOTAL BATTERY VOLTAGE 6.115
INDIVIDUAL CELL VOLTAGES SPECIFIC GRAVITY
CELL# 1 2.042 1.236
CELL# 2 2.035 1.240
CELL# 3 2.038 1.240

END OF CHARGE BATTERY ON FINISHING RATE
CHARGE NUMBER 8
TOTAL BATTERY VOLTAGE 8.027
INDIVIDUAL CELL VOLTAGES SPECIFIC GRAVITY
CELL# 1 2.678 1.270
CELL# 2 2.672 1.274
CELL# 3 2.625 1.268

DISCHARGE NUMBER 9 DURATION OF DISCHARGE 5.78 HR.
DISCHARGE CURRENT 3.00
RECORDED CELL # 1
START OF DISCHARGE BATTERY PARAMETERS
TOTAL BATTERY VOLTAGE 6.730
INDIVIDUAL CELL VOLTAGES SPECIFIC GRAVITY
CELL# 1 2.245 1.270
CELL# 2 2.246 1.274
CELL# 3 2.251 1.268

THE RECORDED CELL CONTROLLED THE DISCHARGE
END OF DISCHARGE BATTERY PARAMETERS
BATTERY CUTOFF VOLTAGE 4.03 REC. CELL CUTOFF VOLTAGE 1.08
CAPACITY OF BATTERY FOR THIS DISCHARGE 100.70 PERCENT
TOTAL BATTERY VOLTAGE 6.178
INDIVIDUAL CELL VOLTAGES SPECIFIC GRAVITY
CELL# 1 2.059 1.243
CELL# 2 2.057 1.243
CELL# 3 2.057 1.240

END OF CHARGE BATTERY ON FINISHING RATE
CHARGE NUMBER 9
TOTAL BATTERY VOLTAGE 8.011
INDIVIDUAL CELL VOLTAGES SPECIFIC GRAVITY
CELL# 1 2.674 1.273
CELL# 2 2.670 1.273
CELL# 3 2.667 1.269

DISCHARGE NUMBER 10 DURATION OF DISCHARGE 3.60 HR.
DISCHARGE CURRENT 4.50
RECORDED CELL # 2
START OF DISCHARGE BATTERY PARAMETERS
TOTAL BATTERY VOLTAGE 6.722
INDIVIDUAL CELL VOLTAGES SPECIFIC GRAVITY
CELL# 1 2.244 1.273

CELL# 2 2.245 1.273
CELL# 3 2.242 1.269

THE RECORDED CELL CONTROLLED THE DISCHARGE
END OF DISCHARGE BATTERY PARAMETERS
BATTERY CUTOFF VOLTAGE 4.69 REC. CELL CUTOFF VOLTAGE 1.40
CAPACITY OF BATTERY FOR THIS DISCHARGE 97.21 PERCENT
TOTAL BATTERY VOLTAGE 6.206
INDIVIDUAL CELL VOLTAGES SPECIFIC GRAVITY
CELL# 1 2.068 1.238
CELL# 2 2.070 1.240
CELL# 3 2.067 1.238

END OF CHARGE BATTERY ON FINISHING RATE
CHARGE NUMBER 10
TOTAL BATTERY VOLTAGE 8.153
INDIVIDUAL CELL VOLTAGES SPECIFIC GRAVITY
CELL# 1 2.714 1.279
CELL# 2 2.724 1.282
CELL# 3 2.720 1.280

DISCHARGE NUMBER 11
DISCHARGE CURRENT 4.50 DURATION OF DISCHARGE 3.67 HR.
RECORDED CELL # 3
START OF DISCHARGE BATTERY PARAMETERS
TOTAL BATTERY VOLTAGE 6.565
INDIVIDUAL CELL VOLTAGES SPECIFIC GRAVITY
CELL# 1 2.186 1.279
CELL# 2 2.193 1.282
CELL# 3 2.188 1.280

END OF DISCHARGE BATTERY PARAMETERS
BATTERY CUTOFF VOLTAGE 4.69 REC. CELL CUTOFF VOLTAGE 1.70
CAPACITY OF BATTERY FOR THIS DISCHARGE 98.99 PERCENT
TOTAL BATTERY VOLTAGE 5.832
INDIVIDUAL CELL VOLTAGES SPECIFIC GRAVITY
CELL# 1 1.942 1.244
CELL# 2 1.938 1.247
CELL# 3 1.942 1.245

END OF CHARGE BATTERY ON FINISHING RATE
CHARGE NUMBER 11
TOTAL BATTERY VOLTAGE 8.014
INDIVIDUAL CELL VOLTAGES SPECIFIC GRAVITY
CELL# 1 2.674 1.417
CELL# 2 2.672 1.418
CELL# 3 2.266 *****

DISCHARGE NUMBER 12
DISCHARGE CURRENT 4.50 DURATION OF DISCHARGE 3.42 HR.
RECORDED CELL # 2
START OF DISCHARGE BATTERY PARAMETERS
TOTAL BATTERY VOLTAGE 6.700
INDIVIDUAL CELL VOLTAGES SPECIFIC GRAVITY
CELL# 1 2.237 1.284
CELL# 2 2.242 1.285
CELL# 3 2.243 1.284

END OF DISCHARGE BATTERY PARAMETERS
BATTERY CUTOFF VOLTAGE 4.65 REC. CELL CUTOFF VOLTAGE 1.67
CAPACITY OF BATTERY FOR THIS DISCHARGE 92.24 PERCENT
TOTAL BATTERY VOLTAGE 6.217
INDIVIDUAL CELL VOLTAGES SPECIFIC GRAVITY
CELL# 1 2.073 1.241
CELL# 2 2.077 1.245

CELL# 3 2.074

1.241

END OF CHARGE BATTERY ON FINISHING RATE

CHARGE NUMBER 12

TOTAL BATTERY VOLTAGE 8.010

INDIVIDUAL CELL VOLTAGES SPECIFIC GRAVITY

CELL# 1 2.671

1.281

CELL# 2 2.675

1.279

CELL# 3 2.666

1.279

DISCHARGE NUMBER 13

DISCHARGE CURRENT 0.50

DURATION OF DISCHARGE 3.65 HR.

RECORDED CELL # 3

START OF DISCHARGE BATTERY PARAMETERS

TOTAL BATTERY VOLTAGE 6.476

INDIVIDUAL CELL VOLTAGES SPECIFIC GRAVITY

CELL# 1 2.184

1.281

CELL# 2 2.187

1.279

CELL# 3 2.185

1.279

THE RECORDED CELL CONTROLLED THE DISCHARGE

END OF DISCHARGE BATTERY PARAMETERS

BATTERY CUTOFF VOLTAGE 4.68 REC. CELL CUTOFF VOLTAGE 1.48

CAPACITY OF BATTERY FOR THIS DISCHARGE 9.15 PERCENT

TOTAL BATTERY VOLTAGE 5.986

INDIVIDUAL CELL VOLTAGES SPECIFIC GRAVITY

CELL# 1 1.995

1.247

CELL# 2 1.995

1.244

CELL# 3 1.992

1.243

END OF CHARGE BATTERY ON FINISHING RATE

CHARGE NUMBER 13

TOTAL BATTERY VOLTAGE 8.006

INDIVIDUAL CELL VOLTAGES SPECIFIC GRAVITY

CELL# 1 2.672

1.276

CELL# 2 2.673

1.278

CELL# 3 2.665

1.276

DISCHARGE NUMBER 14

DISCHARGE CURRENT 4.50

DURATION OF DISCHARGE 3.78 HR.

RECORDED CELL # 2

START OF DISCHARGE BATTERY PARAMETERS

TOTAL BATTERY VOLTAGE 6.616

INDIVIDUAL CELL VOLTAGES SPECIFIC GRAVITY

CELL# 1 2.205

1.276

CELL# 2 2.209

1.278

CELL# 3 2.206

1.276

END OF DISCHARGE BATTERY PARAMETERS

BATTERY CUTOFF VOLTAGE 4.68 REC. CELL CUTOFF VOLTAGE 1.74

CAPACITY OF BATTERY FOR THIS DISCHARGE 102.07 PERCENT

TOTAL BATTERY VOLTAGE 6.227

INDIVIDUAL CELL VOLTAGES SPECIFIC GRAVITY

CELL# 1 2.074

1.241

CELL# 2 2.077

1.244

CELL# 3 2.072

1.240

END OF CHARGE BATTERY ON FINISHING RATE

CHARGE NUMBER 14

TOTAL BATTERY VOLTAGE 8.041

INDIVIDUAL CELL VOLTAGES SPECIFIC GRAVITY

CELL# 1 2.678

1.275

CELL# 2 2.685

1.277

CELL# 3 2.674

1.274

DISCHARGE NUMBER 15
DISCHARGE CURRENT 4.50 DURATION OF DISCHARGE 3.62 HR.
RECORDED CELL # 1
START OF DISCHARGE BATTERY PARAMETERS
TOTAL BATTERY VOLTAGE 6.546
INDIVIDUAL CELL VOLTAGES SPECIFIC GRAVITY
CELL# 1 2.182 1.275
CELL# 2 2.187 1.277
CELL# 3 2.183 1.274

THE RECORDED CELL CONTROLLED THE DISCHARGE
END OF DISCHARGE BATTERY PARAMETERS
BATTERY CUTOFF VOLTAGE 4.68 REC. CELL CUTOFF VOLTAGE 1.38
CAPACITY OF BATTERY FOR THIS DISCHARGE 97.64 PERCENT
TOTAL BATTERY VOLTAGE 5.886
INDIVIDUAL CELL VOLTAGES SPECIFIC GRAVITY
CELL# 1 1.956 1.241
CELL# 2 1.963 1.240
CELL# 3 1.961 1.243

END OF CHARGE BATTERY ON FINISHING RATE
CHARGE NUMBER 15
TOTAL BATTERY VOLTAGE 8.001
INDIVIDUAL CELL VOLTAGES SPECIFIC GRAVITY
CELL# 1 2.670 1.278
CELL# 2 2.674 1.279
CELL# 3 2.663 1.278

DISCHARGE NUMBER 16
DISCHARGE CURRENT 4.50 DURATION OF DISCHARGE 3.67 HR.
RECORDED CELL # 3
START OF DISCHARGE BATTERY PARAMETERS
TOTAL BATTERY VOLTAGE 6.567
INDIVIDUAL CELL VOLTAGES SPECIFIC GRAVITY
CELL# 1 2.187 1.287
CELL# 2 2.192 1.279
CELL# 3 2.189 1.278

END OF DISCHARGE BATTERY PARAMETERS
BATTERY CUTOFF VOLTAGE 4.67 REC. CELL CUTOFF VOLTAGE 1.73
CAPACITY OF BATTERY FOR THIS DISCHARGE 98.99 PERCENT
TOTAL BATTERY VOLTAGE 6.230
INDIVIDUAL CELL VOLTAGES SPECIFIC GRAVITY
CELL# 1 2.075 1.239
CELL# 2 2.078 1.241
CELL# 3 2.073 1.243

END OF CHARGE BATTERY ON FINISHING RATE
CHARGE NUMBER 16
TOTAL BATTERY VOLTAGE 8.013
INDIVIDUAL CELL VOLTAGES SPECIFIC GRAVITY
CELL# 1 2.671 1.274
CELL# 2 2.682 1.278
CELL# 3 2.669 1.273

DISCHARGE NUMBER 17
DISCHARGE CURRENT 4.50 DURATION OF DISCHARGE 3.92 HR.
RECORDED CELL # 1
START OF DISCHARGE BATTERY PARAMETERS
TOTAL BATTERY VOLTAGE 6.666
INDIVIDUAL CELL VOLTAGES SPECIFIC GRAVITY
CELL# 1 2.218 1.274
CELL# 2 2.227 1.278
CELL# 3 2.224 1.273

THE RECORDED CELL CONTROLLED THE DISCHARGE
END OF DISCHARGE BATTERY PARAMETERS
BATTERY CUTOFF VOLTAGE 4.67 REC. CELL CUTOFF VOLTAGE 1.39
CAPACITY OF BATTERY FOR THIS DISCHARGE 105.74 PERCENT
TOTAL BATTERY VOLTAGE 6.186
INDIVIDUAL CELL VOLTAGES SPECIFIC GRAVITY
CELL# 1 2.059 1.245
CELL# 2 2.069 1.245
CELL# 3 2.062 1.240

END OF CHARGE BATTERY ON FINISHING RATE
CHARGE NUMBER 17
TOTAL BATTERY VOLTAGE 7.993
INDIVIDUAL CELL VOLTAGES SPECIFIC GRAVITY
CELL# 1 2.664 1.276
CELL# 2 2.671 1.278
CELL# 3 2.660 1.274

DISCHARGE NUMBER 18
DISCHARGE CURRENT 4.50 DURATION OF DISCHARGE 3.77 HR.
RECORDED CELL # 2
START OF DISCHARGE BATTERY PARAMETERS
TOTAL BATTERY VOLTAGE 6.670
INDIVIDUAL CELL VOLTAGES SPECIFIC GRAVITY
CELL# 1 2.222 1.276
CELL# 2 2.228 1.278
CELL# 3 2.223 1.274

END OF DISCHARGE BATTERY PARAMETERS
BATTERY CUTOFF VOLTAGE 4.67 REC. CELL CUTOFF VOLTAGE 1.75
CAPACITY OF BATTERY FOR THIS DISCHARGE 101.69 PERCENT
TOTAL BATTERY VOLTAGE 6.240
INDIVIDUAL CELL VOLTAGES SPECIFIC GRAVITY
CELL# 1 2.079 1.250
CELL# 2 2.083 1.250
CELL# 3 2.077 1.242

END OF CHARGE BATTERY ON FINISHING RATE
CHARGE NUMBER 18
TOTAL BATTERY VOLTAGE 8.013
INDIVIDUAL CELL VOLTAGES SPECIFIC GRAVITY
CELL# 1 2.667 1.278
CELL# 2 2.679 1.279
CELL# 3 2.667 1.272

DISCHARGE NUMBER 19
DISCHARGE CURRENT 4.50 DURATION OF DISCHARGE 3.98 HR.
RECORDED CELL # 3
START OF DISCHARGE BATTERY PARAMETERS
TOTAL BATTERY VOLTAGE 6.700
INDIVIDUAL CELL VOLTAGES SPECIFIC GRAVITY
CELL# 1 2.233 1.278
CELL# 2 2.241 1.279
CELL# 3 2.235 1.275

END OF DISCHARGE BATTERY PARAMETERS
BATTERY CUTOFF VOLTAGE 4.68 REC. CELL CUTOFF VOLTAGE 1.65
CAPACITY OF BATTERY FOR THIS DISCHARGE 107.55 PERCENT
TOTAL BATTERY VOLTAGE 5.810
INDIVIDUAL CELL VOLTAGES SPECIFIC GRAVITY
CELL# 1 1.933 1.245
CELL# 2 1.942 1.242
CELL# 3 1.935 1.238

END OF CHARGE BATTERY ON FINISHING RATE
CHARGE NUMBER 19
TOTAL BATTERY VOLTAGE 8.015
INDIVIDUAL CELL VOLTAGES SPECIFIC GRAVITY
CELL# 1 2.673 1.279
CELL# 2 2.680 1.283
CELL# 3 2.670 1.277

DISCHARGE NUMBER 20
DISCHARGE CURRENT 4.50 DURATION OF DISCHARGE 3.78 HR.
RECORDED CELL # 3
START OF DISCHARGE BATTERY PARAMETERS
TOTAL BATTERY VOLTAGE 6.628
INDIVIDUAL CELL VOLTAGES SPECIFIC GRAVITY
CELL# 1 2.212 1.279
CELL# 2 2.217 1.283
CELL# 3 2.214 1.277

THE RECORDED CELL CONTROLLED THE DISCHARGE
END OF DISCHARGE BATTERY PARAMETERS
BATTERY CUTOFF VOLTAGE 4.63 REC. CELL CUTOFF VOLTAGE 1.50
CAPACITY OF BATTERY FOR THIS DISCHARGE 102.15 PERCENT
TOTAL BATTERY VOLTAGE 6.219
INDIVIDUAL CELL VOLTAGES SPECIFIC GRAVITY
CELL# 1 2.075 1.242
CELL# 2 2.078 1.242
CELL# 3 2.071 1.243

END OF CHARGE BATTERY ON FINISHING RATE
CHARGE NUMBER 20
TOTAL BATTERY VOLTAGE 8.119
INDIVIDUAL CELL VOLTAGES SPECIFIC GRAVITY
CELL# 1 2.699 1.280
CELL# 2 2.721 1.280
CELL# 3 2.700 1.276

LIST OF REFERENCES

1. G. W. Vinal, Storage Batteries, 4th ed., Wiley, 1955.
2. H. G. Brown, The Lead Storage Battery, 4th ed., John Sherratt & Son, 1959.
3. G. Smith, Storage Batteries, 1st ed., Sir Isaac Pitman and Sons Ltd., 1964.
4. A. C. Simon and others, The Structure of the Pb/PbSO₄ Electrode in the Reduced State and the Changes Produced by Lignin Derivatives and BaSO₄; Electrochimica Acta, p. 739-743, 1974.
5. International Lead Zinc Research Organization, Inc., Report LE-82-84, Pastes and Grids for the Lead Acid Battery, by E. J. Ritchie and others, p. 2-5 - 2-11, 31 Dec 1971.
6. U. Heubner and H. Sandig, Lead Alloys for Grids of SLI-Batteries and Sealed Batteries, paper presented at 4th International Lead Conference, Hamburg, Germany, 21-24 September 1971.
7. J. Burbank, "The Role of Antimony in Positive Plate Behavior in the Lead-Acid Cell," Journal of the Electrochemical Society, Vol. 111, No. 10, October 1964.
8. J. Perkins and G. R. Edwards, "Review Microstructural Control in Lead Alloy for Storage Battery Applications," Journal of Material Science, p. 136-158, 10, 1975.
9. M. V. Rose and J. A. Yong, Lead-Calcium (-tin) Alloys - Properties and Prospects, a paper presented at International Lead Conference, 5th, Paris, France, 18-22 November 1974.
10. International Lead Zinc Research Organization, Inc., Semi Annual Report Project LE-197, Shedding of Positive Active Material, by Seisaku Hattori and others, 20 September 1975.
11. Naval Ships' Technical Manual, p. 25, Department of the Navy, 1 June 1973.
12. H. E. Haring and U. B. Thomas, "Electrochemical Behavior of Lead, Lead Antimony, and Lead Calcium Alloys in Storage Cells," Transactions of the Electrochemical Society, vol 68, p. 293, 1935.

13. J. Burbank, "Morphology of PbO_2 in the Positive Plates of Lead Acid Cells," Journal of the Electrochemical Society, vol. 111, p. 765, July 1964.
14. J. Burbank, and E. J. Ritchie, " PbO_2 in the Lead-Acid Cell," Journal of the Electrochemical Society, vol. 116, p. 125, January 1969.
15. S. Tudor, A. Weisstuch and S. H. Davang, "Application of Autoradiographic Techniques to Battery Research," Journal of Electrochemical Technology, v. 3, p. 90, Mar-April 1964.
16. S. Tudor, A. Weisstuch and S.H. Davang, "The Lead-Calcium Grid Battery with Phosphorus Acid Additive," Journal of Electrochemical Technology, v. 4, p. 406, July-Aug 1966.
17. S. Tudor, A. Weisstuch and S. H. Davang, "Positive Plate Sulfation Processes in Thin- and Thick Plate PbCa Grid Batteries," Journal of Electrochemical Technology, v. 5, p. 21, Jan-Feb 1967.
18. D. L. Douglas, and G. W. Mao, Power Sources, v. 4, p. 561, 1972.
19. S. M. Caulder, J. S. Murdays and A. C. Simon, "Hydrogen Loss Concept of Battery Failure: The PbO_2 Electrode," Journal of the Electrochemical Society, v. 120, p. 1515, November 1973.
20. S. M. Caulder and A. C. Simon, "Thermal Decomposition Mechanism of Formed and Cycled Lead Dioxide Electrodes at Its Relationship to Capacity Loss and Battery Failure," Journal of the Electrochemical Society, v. 121, p. 1546, December 1974.
21. Gould Inc., Instruction Sheets Gould Type TPX-61-E, April 1967.
22. Gould Inc., Letter AJP/276/14 to LT. J. L. Pokorny, Subject: Gould TLX-39-B Battery Plates 27 February 1976.
23. Department of the Navy Naval Sea Systems Command, Service Manual for U. S. Submarine Main Storage Battery Guppy 1 Mod C Type TLX-39-13, NAVSEA 0962-073-4010.
24. Cambridge Scientific Instruments Limited, Stereoscan S4-10 Scanning Electron Microscope, Instruction Manual TL 1116-0M-96118-0002, Issue 1.
25. A. C. Simon, Stress Corrosion in the Grids of the Lead Acid Storage Battery, Journal of the Electrochemical Society, v. 114, No. 1, January 1967.

26. Naval Research Laboratory Report 7256, Anodic Crystallization on Pure and Antimonial Lead in Sulfuric Acid, by J. Burbank, 24 May 1971.
27. M. T. Coyle, A Microstructural Comparison of Positive Floated and Trickle Discharge Operations on the Positive Electrodes of Submarine Storage Batteries with Lead-Calcium Grids, M.S. Thesis, Naval Postgraduate School, Monterey, Calif., 1976.
28. P. Ruetschi and B. D. Cahan, "Anodic Corrosion and Hydrogen and Oxygen Overvoltage on Lead and Lead Antimony Alloys," Journal of the Electrochemical Society, v. 104, p. 406, 1957.
29. J. Burbank, "Anodication of Lead and Lead Alloys in Sulfuric Acid," Journal of the Electrochemical Society, v. 104, December 1957.
30. J. Burbank, A. Simon, and E. Willihnganz, The Lead Acid Cell from Advances in Electrochemistry and Electrochemical Engineering, v. 8 (ed. P. Delahy and C. W. Tobias) 1971.
31. Battery Applications, Lead Research Digest, No. 31, 1973.
32. A. C. Simon, S. M. Caulder, and J. T. Stemmler, "Structural Transformations of the PbO₂ Active Material during Cycling," Journal of Electrochemical Society, v. 122, No. 4, April 1975.
33. A. C. Simon, "Microscope Techniques for the Study of Electrochemical Processes," Journal of the Electrochemical Society, v. 1, p. 82, April 1963.

INITIAL DISTRIBUTION LIST

	No. Copies
1. Defense Documentation Center Cameron Station Alexandria, Virginia 22314	2
2. Library, Code 0142 Naval Postgraduate School Monterey, California 93940	2
3. Department Chairman, Code 59 Department of Mechanical Engineering Naval Postgraduate School Monterey, California 93940	2
4. Professor A. J. Perkins, Code 59Ps Department of Mechanical Engineering Naval Postgraduate School Monterey, California 93940	7
5. LT. John L. Pokorny, USN 4925 Hickory Street Omaha, Nebraska 68106	4