

AD-A033 843

DEFENSE SYSTEMS MANAGEMENT SCHOOL FORT BELVOIR VA  
A FRAMEWORK FOR PLANNING AND CONTROL IN THE PROGRAM OFFICE.(U)  
NOV 75 S H ANDERSON

F/G 5/1

UNCLASSIFIED

NL

| OF |

AD  
A033843



END  
DATE  
FILMED  
2-77

# DEFENSE SYSTEMS MANAGEMENT SCHOOL



ADA 033843

## PROGRAM MANAGEMENT COURSE INDIVIDUAL STUDY PROGRAM

A FRAMEWORK FOR PLANNING  
AND CONTROL IN THE PROGRAM  
OFFICE

STUDY PROJECT REPORT  
PMC 75-2

SUSAN H. ANDERSON  
LCDR USN

DDC  
RECEIVED  
DEC 30 1978  
A

FORT BELVOIR, VIRGINIA 22060

DISTRIBUTION STATEMENT A

Approved for public release;  
Distribution Unlimited

ANDERSON  
75-2

REPORT DOCUMENTATION PAGE		READ INSTRUCTIONS BEFORE COMPLETING FORM
1. REPORT NUMBER <b>6</b>	2. GOVT ACCESSION NO.	3. RECIPIENT'S CATALOG NUMBER <b>9</b>
4. TITLE (and Subtitle) <b>A FRAMEWORK FOR PLANNING AND CONTROL IN THE PROGRAM OFFICE.</b>		5. TYPE OF REPORT & PERIOD COVERED <b>Study Project Report 75-2</b>
7. AUTHOR(s) <b>10/ Susan H. Anderson</b>		6. PERFORMING ORG. REPORT NUMBER
<b>11/ Nov 75</b>		8. CONTRACT OR GRANT NUMBER(s) <b>12/ 33p.</b>
9. PERFORMING ORGANIZATION NAME AND ADDRESS <b>DEFENSE SYSTEMS MANAGEMENT COLLEGE FT. BELVOIR, VA 22060</b>		10. PROGRAM ELEMENT, PROJECT, TASK AREA & WORK UNIT NUMBERS
11. CONTROLLING OFFICE NAME AND ADDRESS <b>DEFENSE SYSTEMS MANAGEMENT COLLEGE FT. BELVOIR, VA 22060</b>		12. REPORT DATE <b>75-2</b>
14. MONITORING AGENCY NAME & ADDRESS (if different from Controlling Office)		13. NUMBER OF PAGES <b>31</b>
		15. SECURITY CLASS. (of this report) <b>UNCLASSIFIED</b>
		15a. DECLASSIFICATION/DOWNGRADING SCHEDULE
16. DISTRIBUTION STATEMENT (of this Report) <b>UNLIMITED</b>		
17. DISTRIBUTION STATEMENT (of the abstract entered in Block 20, if different from Report)		
18. SUPPLEMENTARY NOTES		
19. KEY WORDS (Continue on reverse side if necessary and identify by block number) <b>SEE ATTACHED SHEET</b>		
20. ABSTRACT (Continue on reverse side if necessary and identify by block number) <b>SEE ATTACHED SHEET</b>		

DISTRIBUTION STATEMENT A  
Approved for public release;  
Distribution Unlimited

DEFENSE SYSTEMS MANAGEMENT SCHOOL

**STUDY TITLE:** A Framework for Planning and Control in the Program Office

**STUDY PROJECT GOALS:**

To prepare a section of the Fundamentals of Program Management course to be presented to PMC 76-1.

To test my understanding of the subject matter and identify areas in which I need more information.

**STUDY REPORT ABSTRACT:**

This report presents a model which can be used to set up a planning and control system in the program office. It presents the evolution of the model and different ways in which it can be viewed. The model is then joined with networking to show how the program manager can track technical performance, schedule and cost.

**KEY WORDS**

RESOURCES      MANAGEMENT      APPROPRIATIONS      BUDGETARY CONTROL      PPBS  
MILITARY FUNDS

SEARCHED	INDEXED
SERIALIZED	FILED
UNANNOUNCED	<input type="checkbox"/>
JUSTIFICATION	<input type="checkbox"/>
BY.....	
DISTRIBUTION/AVAILABILITY CODES	
DISC. ATTN. ENG. OR SPECIAL	
A	

**NAME, RANK, SERVICE:**  
Susan H. Anderson, LCDR, USN

**CLASS:**  
PMC 75-2

**DATE:**  
November 1975

DEFENSE SYSTEMS MANAGEMENT SCHOOL

**STUDY TITLE:** A Framework for Planning and Control in the Program Office

**STUDY PROJECT GOALS:**

To prepare a section of the Fundamentals of Program Management course to be presented to PMC 76-1.

To test my understanding of the subject matter and identify areas in which I need more information.

**STUDY REPORT ABSTRACT:**

This report presents a model which can be used to set up a planning and control system in the program office. It presents the evolution of the model and different ways in which it can be viewed. The model is then joined with networking to show how the program manager can track technical performance, schedule and cost.

**NAME, RANK, SERVICE:**

Susan H. Anderson, LCDR, USN

**CLASS:**

PMC 75-2

**DATE:**

November 1975

**A FRAMEWORK FOR  
PLANNING AND CONTROL  
IN THE PROGRAM OFFICE**

**Study Project Report  
Individual Study Program**

**Defense Systems Management School  
Program Management Course  
Class 75-2**

**by**

**Susan H. Anderson  
LCDR                      USN**

**November 1975**

**Study Project Advisor  
LCDR Joseph E. Callahan, USN**

**This study project represents the views, conclusions and  
recommendations of the author and does not necessarily reflect  
the official opinion of the Defense Systems Management School  
or the Department of Defense.**

§ TABLE OF CONTENTS

EXECUTIVE SUMMARY..... ii  
ACKNOWLEDGMENTS..... iii  
SECTION  
I. INTRODUCTION..... 2  
II. A PLANNING AND CONTROL MODEL..... 4  
III. DEVELOPMENT OF A PLANNING AND CONTROL SYSTEM..... 19  
BIBLIOGRAPHY..... 25

## EXECUTIVE SUMMARY

The purpose of this project is to present a model of the systems acquisition process at the contractor level, emphasizing the communication flows involved between the Department of Defense Program Manager and the contractor. The model is then joined with networking to show points where the program manager can receive information on the progress of his program in terms of technical performance, schedule and cost. It is intended to provide the inexperienced program manager with a tool for setting up a planning and control system.

### ACKNOWLEDGMENTS

I would like to acknowledge the assistance of Lieutenant Commander Joseph E. Callahan, USN, who provided the basic model for this report, and spent many hours increasing the depth of the author's knowledge.

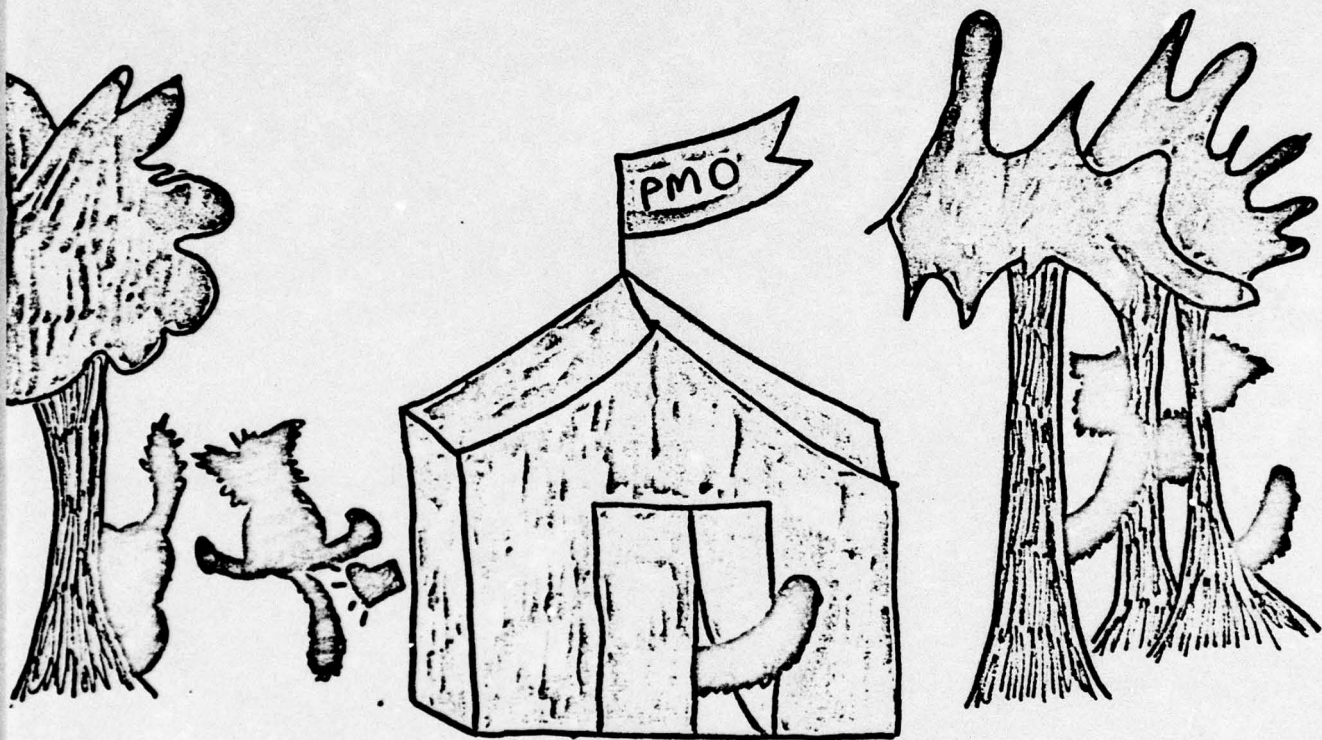

A FRAMEWORK FOR PLANNING AND CONTROL

IN THE PROGRAM OFFICE

## SECTION I: INTRODUCTION

A program manager and his deputy were on a hunting trip. One morning the deputy woke up early and went into the brush to get a lead on a tiger which was reported to be in the vicinity of their camp. The program manager was about to join his companion when he heard two shots and a blood-curdling roar. The deputy ran toward the tent yelling "Open the flap, open the flap!" Just as the program manager ripped open the flap, the deputy ran into the tent, followed by a huge tiger not twenty yards behind him. As the deputy ran through the tent and out the rear flap, he shouted, "You take care of this one while I bring in another!" (2:v)<sup>1</sup>

Unfortunately, the program manager does not usually have to look for tigers. They are more than happy to come looking for him. Various types of tigers have been introduced in previous sessions of this course, and will be expanded upon by other courses and guest lecturers. How, then, does the program manager remain in control of his situation?

---

<sup>1</sup> This notation will be used throughout the report for sources of quotations and major references. The first number is the source listed in the bibliography. The second number is the page in the reference.

First of all, he can plan a course of action to avoid arousing those tigers whose presence are known. As insurance, he can develop alternative routes to be used if a tiger shifts position. And perhaps, most importantly, he can deprive the tiger of the element of surprise. By knowing what is happening in his program, the program manager can greet a tiger with a loaded gun.

The remainder of this course will be devoted to the areas of planning and control.

## SECTION II; A PLANNING AND CONTROL MODEL

The managerial subsystem has been defined by Kast and Rosenzweig as consisting of three levels: strategic, coordinative and operating. (6:358) Activities at the strategic level involve decisions on the objectives of the organization, on changes to these objectives, and on policies which govern the acquisition, use and disposition of these resources. The operating level is concerned with ensuring that specific tasks are carried out effectively and efficiently in order to produce a desired end item. The coordinative level acts as an interface between the other two, ensuring that resources are obtained and used to translate organizational goals into operational products.

Figure 1 represents a breakdown of a major weapon system acquisition managerial subsystem. For the sake of simplicity, it does not include the industry corporate structure nor a number of other strategic level offices and people. The strategic level decides what threat needs to be met and what resources are available to meet this threat. The operating level manufactures the weapons desired. The coordinative level is responsible for translating the objectives to be met into specifications for a certain piece of hardware and ensuring that the hardware is delivered as specified on time and within cost. Department of Defense and

WEAPON SYSTEM ACQUISITION MANAGERIAL SUBSYSTEM

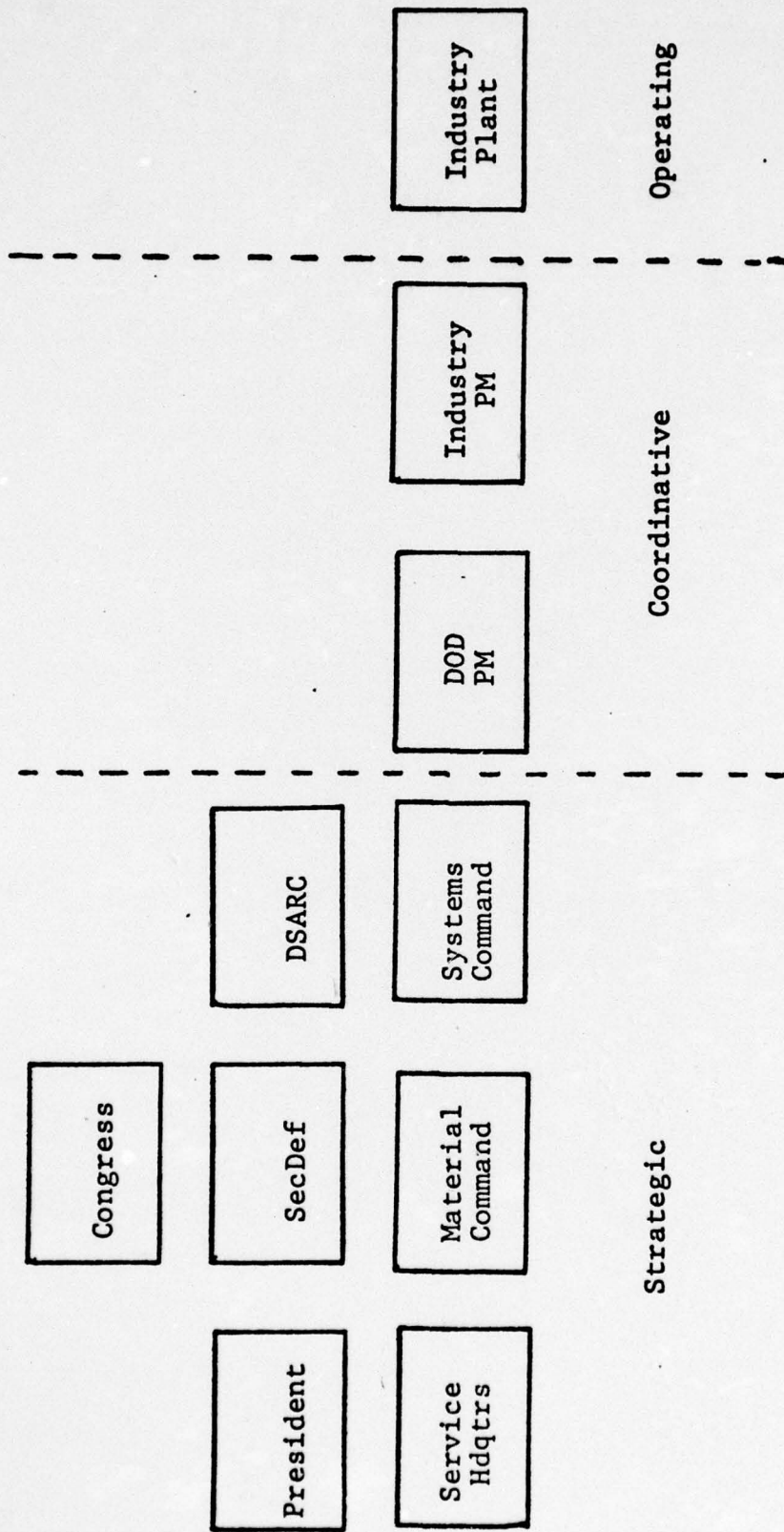

Figure 1

and industry share this latter role and work together at this level. In order to accomplish this task, the coordinative level must be concerned with planning and control.

Planning can be considered as a process and can be described as a series of steps:

- 1) define the objective
- 2) generate alternatives to satisfy the objective
- 3) select the preferred alternative
- 4) communicate the desired action

Control is also a process with a series of steps:

- 1) define the characteristic
- 2) establish a sensor to monitor the characteristic
- 3) compare the characteristic to a standard
- 4) take action if warranted

Conceptually, planning and control are often discussed as separate entities. Practically, this separation does not exist. Although they call for different types of mental activity, they both relate to the same major categories of activities carried on in an organization at the same time, by the same people, in the same situations. Planning without control is a wish. Control without a planned standard is impossible.

The program managers must depend on the operating level, the industrial plant, for information. Based on this information, they can develop and revise plans and establish

a control system. In order to illustrate planning and control concepts, a model will be used. (5) The model will attempt to represent the planning and control communication between the Department of Defense program manager, the industry program manager and the industrial plant. Communications between the program manager and his superiors have already been discussed in this course and in OSAM (Overview of System Acquisition Management). This is a model of formal communications. It does not represent telephone calls nor the grapevine. The model is generalized, and applies equally to all types of weapons. It incorporates one assumption: the communication flow dealing with technical matters is handled by a different segment of an industrial organization than the flow devoted to cost, funds and contracts.

The basic model is presented in Figure 2. As we proceed, additions will be made, and sections will be isolated and expanded.

Viewing it from top to bottom, the model is divided into three rows of elements. The top row represents those organizational elements directly concerned with the specific technical aspects of the product being developed. Of interest here is the flow of technical communications and the attendant documents involved, such as proposals, plans, specifications, drawings, records, and reports.

The bottom row is concerned with the functions that must

A PLANNING AND CONTROL MODEL

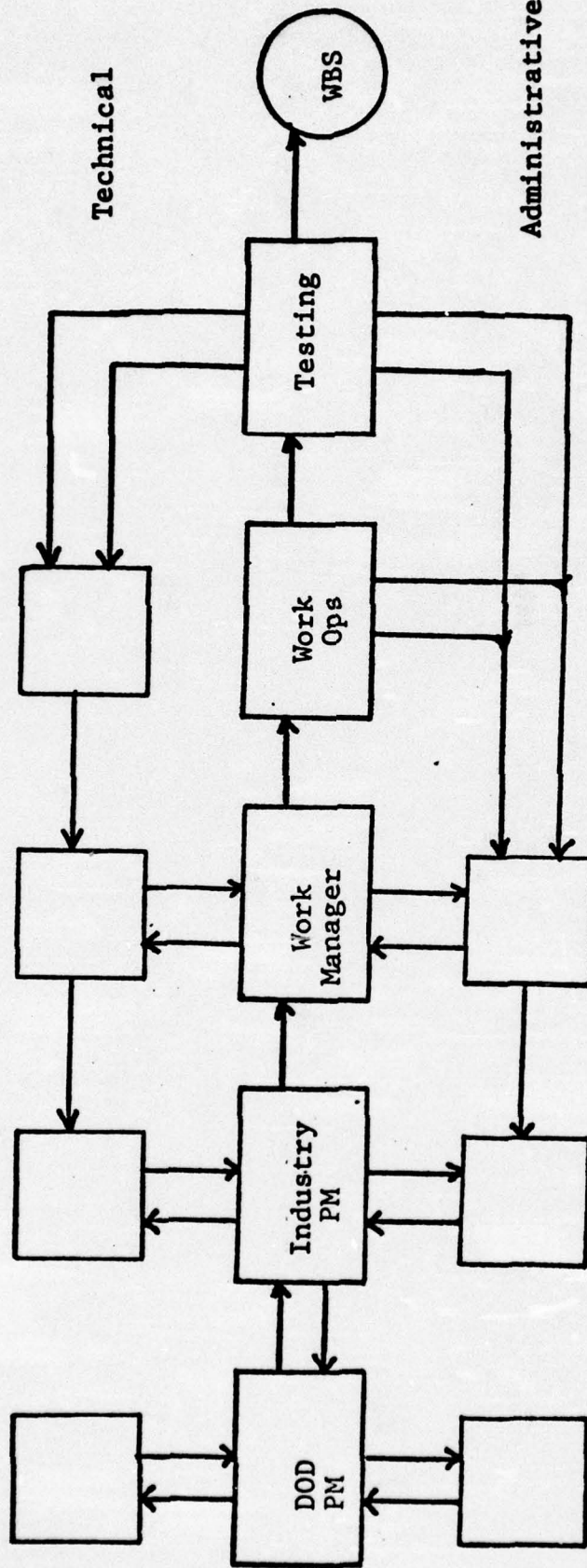

Figure 2

be accomplished independent of the product. Included here are areas such as administration, logistics, financial, contracting and legal.

The middle row, reading from left to right, is a scalar representation of the management involved in producing the product. Elements in this row coordinate, direct, integrate and control the activities of the top and bottom rows toward the production of the product represented in the model by a WBS. Proceeding from left to right, we have represented the Department of Defense-Industry interface; the industry program manager interface with his functional managers and the subsequent interface between the work manager and the worker himself. Finally represented is the test personnel. Testing may range from approval of a drawing or a Quality Assurance inspection to the very formal final test of a complete product. If the end item produced is not in itself the complete product, the additional step of integration must be added to the model.

Let us now examine the model in some depth and introduce some abbreviations.

**D** will represent the Department of Defense program manager and his staff. The box in the top row serves to represent the various functional organizations which provide technical support to the program office. The box in the lower row is the variety of other support he receives, such as

contracting and financial. The communications between the functional offices and the program office may be the result of Memoranda of Agreement derived from the charter, or they could be required reports developed from a particular tasking statement. These flows exist without regard to the size of the program office. In a weak matrix, the flow to/from the support activities is very critical because of the program office's degree of dependence on these activities. In a large office, such as TRIDENT, B-1 or SAFEGUARD these flows would be less critical due to the strong internal capability of the program office itself. Hence, the volume and rate of flow does depend on the size of the program office.

**KR** represents the industry program manager and his immediate, dedicated staff. In the acquisition of a weapons system, the Department of Defense program manager may have multiple contractors as in the case of a competitive prototyping effort. Additionally, if GFE (Government Furnished Equipment) is involved, the source of the GFE can be viewed as a contractor for the purposes of project planning and control. Laboratories might be perceived in a similar manner. The contract, in the CDRL (Contract Data Requirements Test), assures that formal communications will exist between the respective program managers.

The organization to which the industrial program manager communicates for technical support is the corporation's

engineering department. Depending upon the particular corporate organization and importance of the product to the economic well being of the organization, the communications may be very formal and "contract - like" or rather informal. The same will hold true with regard to the communication between the industrial program manager and his financial, marketing and other support organizations.

**WM** represents the industrial work manager, in charge of resource and production planning, and production scheduling. He communicates with the **WO**, the work operation, the people responsible for manufacturing the end item. Once the item is produced, it is submitted to **T**, the test personnel, for checkout.

The model can be varied to give insight into the acquisition process. Figure 3 is one such view of the model. It represents a product obtained via a fixed price contract. Department of Defense and industry sign a contract for a described end item at a fixed price. The industry partner develops and delivers it with no intermediate communications. While this is how the vast majority of products are procured, it does not apply to weapons systems acquisition.

Because of the rapid expansion of technology in the 50's and 60's, emphasis and attention was focused on the engineering area of the model. Technical superiority was all important. Visibility into production was somewhat as illustrated in

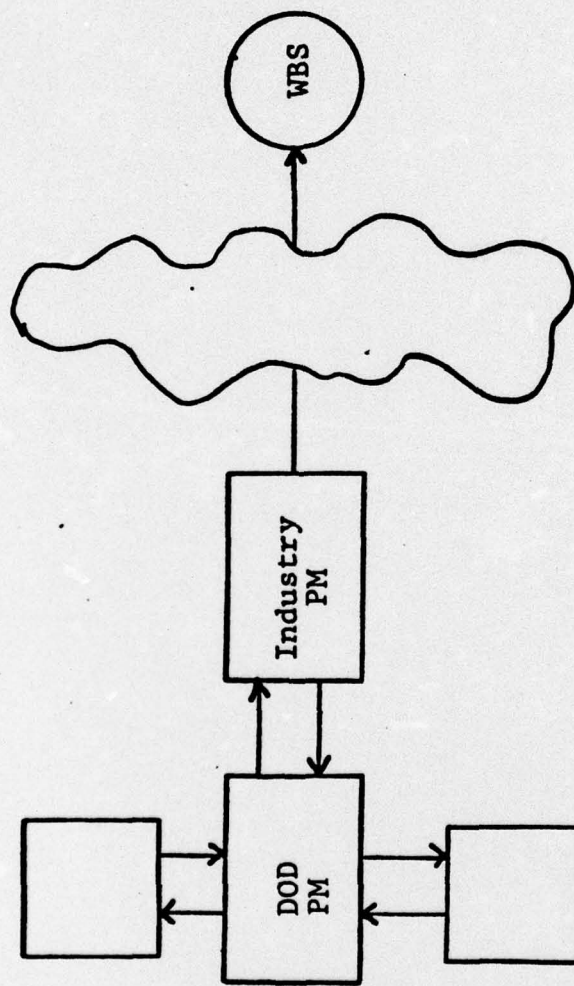

Figure 3

Figure 4. The emphasis was first on technical performance and next on schedule, with cost running a poor third. Planning and control was focused on the upper, technical loop with interest given to the bottom loop only in terms of how manpower, material and capital equipment affected the schedule.

In the austere fiscal climate of the 70's, however, cost has emerged from the woodwork. Cost, schedule and technical performance are now regarded as equal considerations, with cost being more equal than the other two. Thus the program manager must be concerned with the complete model, examining it for areas which will provide information for planning and control of costs, as well as technical performance and schedule.

A closer look at Figure 2 could produce the communication flow shown in Figure 5. Within the contract is a Statement of Work (SOW). This delineates what is to be done. It contains a specification tree, list of standards, the delivery schedule and test requirements. Upon receipt of the SOW, the contractor develops a Bill of Materials (BOM). Based on the BOM, orders are developed by the purchasing department. The orders are then conveyed to the suppliers. Resources are obtained and entered into inventory, ready to be withdrawn when needed for work operations. The end item is built and results of the testing forwarded to the engineer. He tells

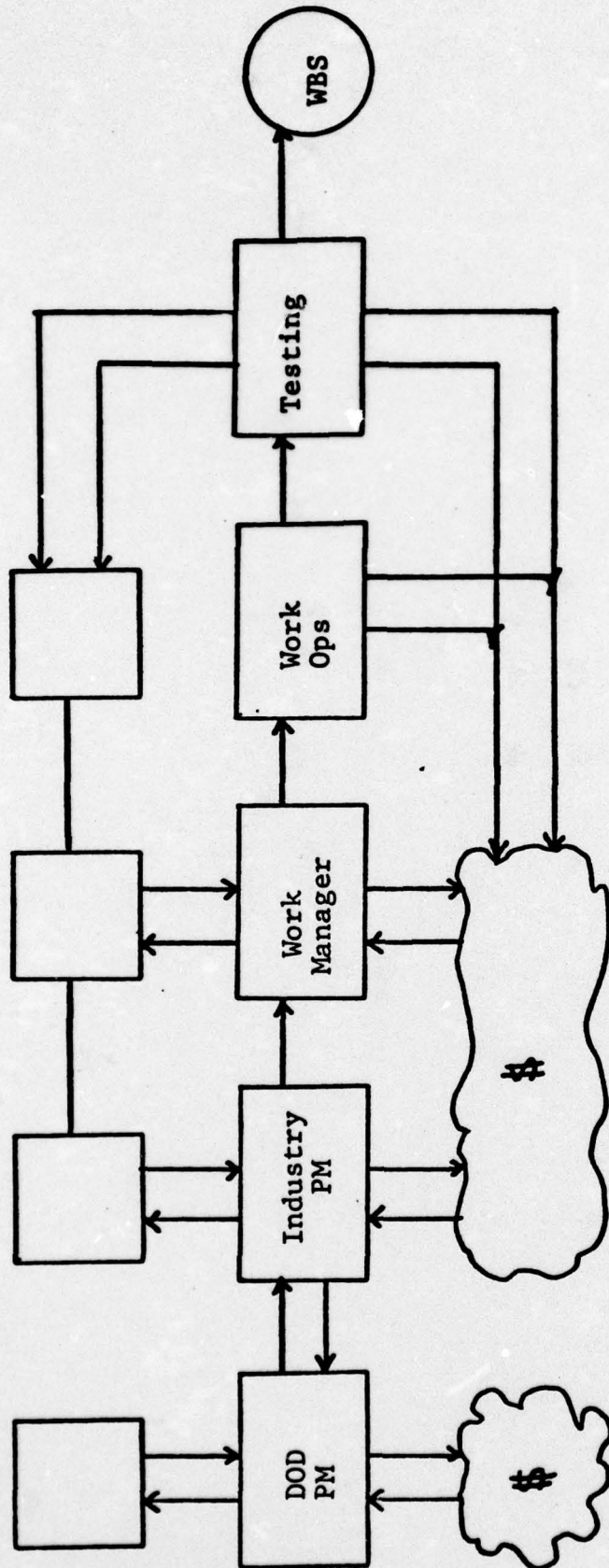

Figure 4

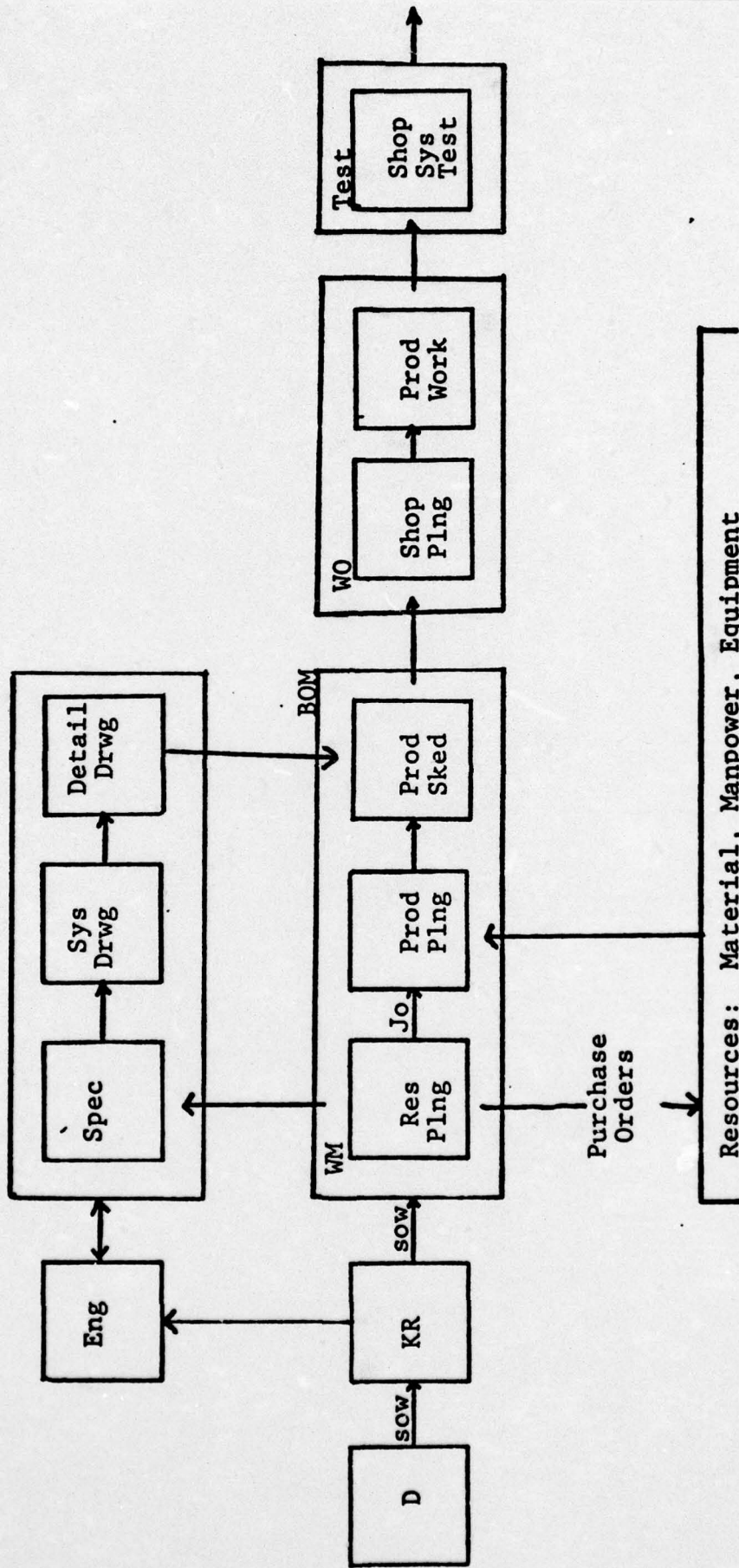

Figure 5

the industry program manager the product is good and the customer accepts it. A simple procedure as shown in Figure 6.

In the real world, however, life is not quite so simple. Purchasing is preceded by a variety of decisions: is it already in the inventory, should we make or buy, go sole source or competitive? Similar decisions are also made to obtain manpower. A forecast must be made, manpower checked with personnel, advertising put out to the market place. New personnel must be entered into the inventory and trained in time to meet the schedule. Items such as skill, salary, benefits, availability and location must be considered. Decisions on capital equipment such as facilities and tooling can be expanded in a similar fashion.

The one resource not explicitly shown in this model is money. Funds are a resource which industry must consume in order to acquire the other required resources. Consumed funds are translated to cost, and cost is now an important concern in weapons acquisition.

How, then, can this model be useful to the program manager in planning and controlling? Costs occur after the fact. Testing takes place after the product is built, likewise technical performance measurement. The value of the model is derived from its predictive ability. If a drawing is not completed on schedule, purchasing will be delayed. If an item is not available, the production schedule will slip.

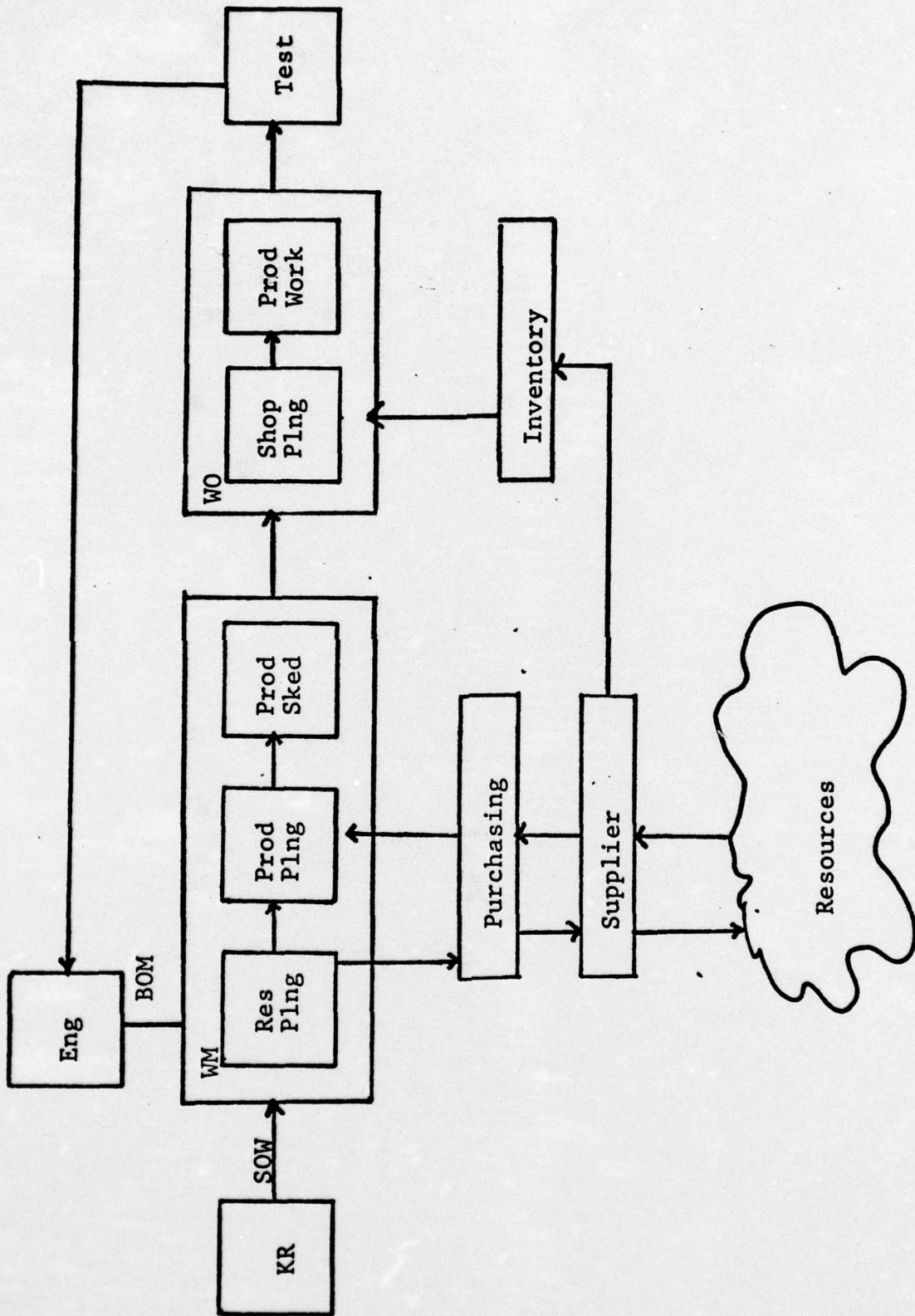

Figure 6

Slips in schedule cost money. Workers receive their salary regardless of whether the machines are idle. Fixed costs continue,

A great deal of important communication takes place prior to the actual bending of metal. Tracking of the flows (both rate and volume) of resources should serve to predict how costs and schedules will be impacted. Control points can be established on major communication flows and data bases generated to provide information to the management chain. Prediction eliminates surprises and promotes the development of alternate plans. The program manager is in control.

### SECTION III; DEVELOPMENT OF A PLANNING AND CONTROL SYSTEM

Given the Planning and Control Model and a discussion of the techniques of networking, a control system can now be developed for a weapons system program.

The first consideration is to determine what should be controlled. What are the critical factors to be tracked? What characteristics of the system should be monitored to ensure the success of the program? The obvious place to start is with the WBS (Work Breakdown Structure). What WBS elements have the greatest risk attached, be it technical or cost? Control should be centered around these elements.

Next the program manager must match the high risk work breakdown structure elements with his staff. What skills will be needed in his office and when should they be phased in and out? Is a special talent required only in the conceptual phase or will this talent be required throughout the program? What experts will be needed at a later time? The program manager can staff his office to meet the timetable of critical elements.

Establishment of the industry-Department of Defense interfaces must be considered. The program manager must determine with whom he will be involved, contractors, other program managers controlling government furnished equipment, laboratories who will be performing the work. These interfaces

must be carefully defined and expectations of communication flows established. Knowledge of the industry base and how the tasks will be allocated is essential.

In addition to the above mentioned interfaces, the program manager must establish the other members of his team. What functional areas will he need for support? What can he expect from the prospective user? Who will help in program advocacy? He must establish contacts with the testing personnel, and determine his requirements for training.

Having taken care of his personnel needs, the program manager can then establish the flow of the work and determine where the control points should be set. This implies a detailed knowledge of the technical design process and the supportive administrative functions.

From these flows, a network can be set up. The work breakdown structure elements must be sequenced and integrated, and constraints identified. This network is then subdivided to reflect greater detail, or a particular time horizon, or an organizational role, or a number of other factors.

Finally, the program manager must determine reporting points which will provide him with a way to monitor chosen characteristics of his program. These reports provide the information which joins planning and control.

The following is an illustration of how this system works.

Figure 7 is a simplified representation of the communication flows involved in manufacturing one high risk sub-element of a weapons system. Numbers have been placed to show the sequence of events,

1. The DOD PM gives the KR the SOW.
2. The KR gives the SOW to his engineering staff.
3. The engineering staff draws up a BOM and gives it to work management.
4. WM submits a purchase request.
5. Purchasing gets the materials.
6. The materials are put into inventory.
7. WM is notified that the materials have arrived.
8. WM gives a production schedule to Work Operations.
9. WO manufactures the product and gives it to the test personnel.
10. T reports the results to the engineers.
11. The engineers report to the KR.
12. KR reports the completion to the DOD PM.

These activities can then be plotted against a time schedule as in Figure 8. It can be seen that a network now exists which provides additional information. The horizontal lines show the time sequence, and the vertical lines represent the interfaces which must occur. Further, if the vertical lines are extended, it can be seen that reports could be received to indicate progress. Other vertical lines can be

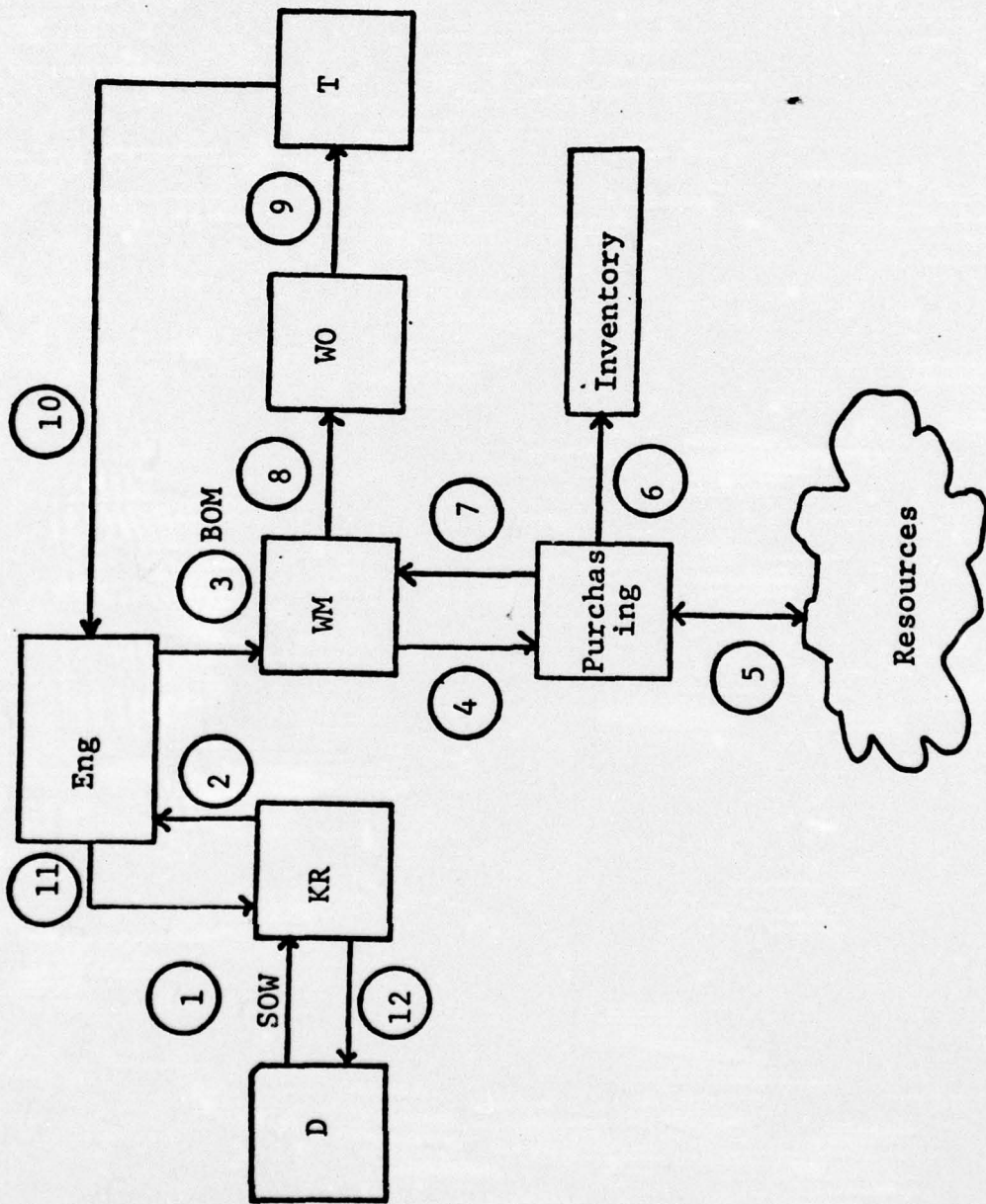

Figure 7

TIME →

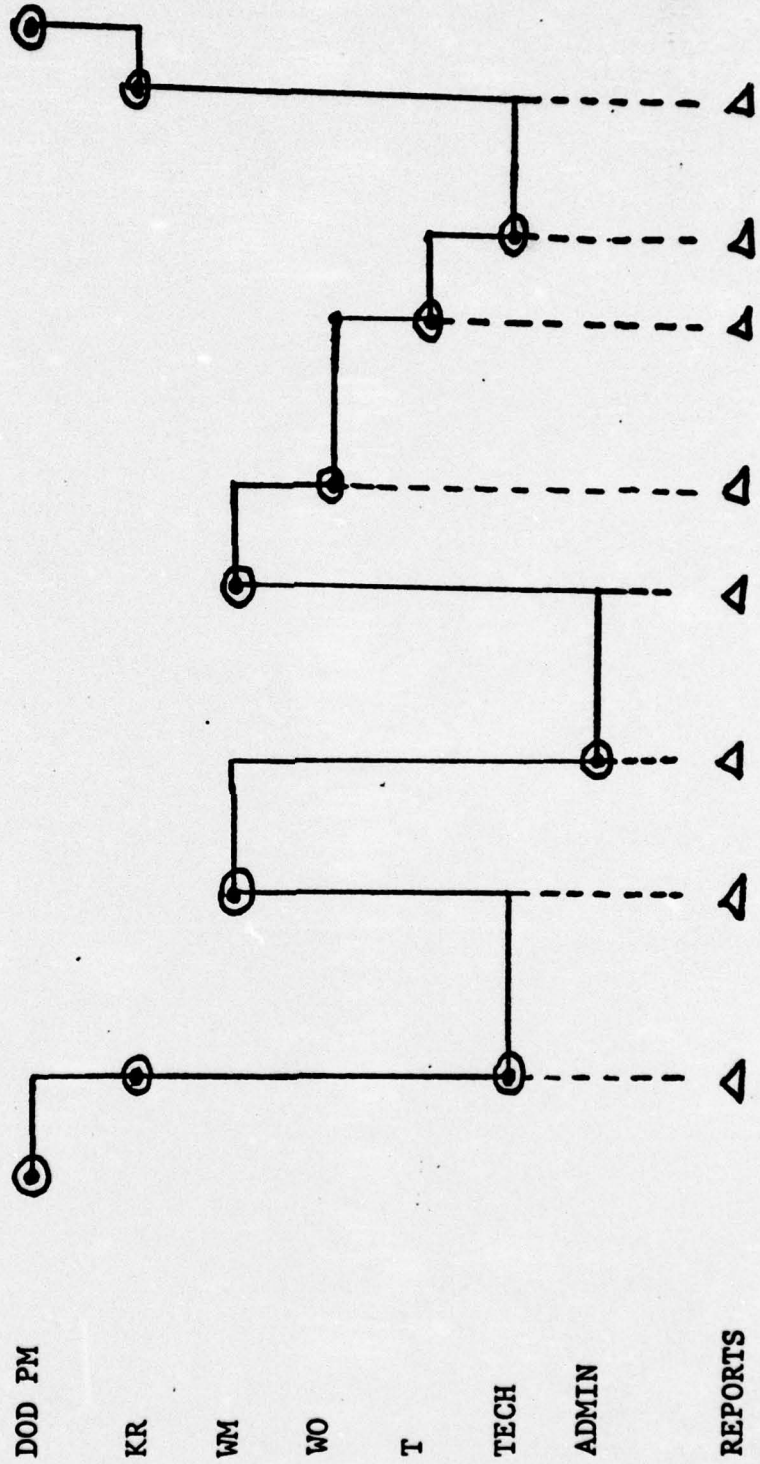

Figure 8

drawn to delineate time periods for which a subnet might be derived. The program manager now has a powerful tool at his disposal that will enable him to track technical performance, cost and schedule,

Given that this information is useful, the program manager must now determine how useful it is in dollars and cents. How much is he willing to pay for it? How much does he really need? Can the contractor provide it from his own system? This will be the subject of the next class.

## Bibliography

1. Anthony, Robert N., Planning and Control Systems: A Framework for Analysis. Boston: Division of Research, Graduate School of Business Administration, Howard University, 1965.
2. Baumgartner, John Stanley, Project Management. Homewood Illinois: Richard D. Irwin, Inc., 1963.
3. Blumenthal, Sherman C., Management Information Systems: A Framework for Planning and Development. Englewood Cliffs, New Jersey: Prentice-Hall, Inc., 1969.
4. Callahan, J. E., M. G. Ransdell and C. N. Anderson, The Commander and Management Information Systems. Newport, Rhode Island: Naval War College, 1971.
5. Callahan, J. E., Planning and Control Model. Distributed at Defense Systems Management School, 1975.
6. Kast, Fremont E. and James E. Rosenzweig, Organization and Management; A Systems Approach. Seattle: Graduate School of Business Administration, University of Washington, 1974.