

AD-A033 890

TEL-AVIV UNIV (ISRAEL) SCHOOL OF ENGINEERING
CONTINUUM THEORIES FOR CYLINDRICAL WAVE PROPAGATION IN A LAMINA--ETC(U)
JUL 76 Y BENVENISTE
TAU-SOE/229-76

F/G 20/14

AF-AFOSR-3014-76

NL

UNCLASSIFIED

AFOSR-TR-76-1246

| OF |
ADA033890



END

DATE
FILMED
2 - 77

ADA 033890

AFOSR - TR - 76 - 1246

f

12

Scientific Report No. 1

July 1976

TAU-SOE/229-76

Grant AFOSR 76-3014

CONTINUUM THEORIES FOR CYLINDRICAL
WAVE PROPAGATION IN A LAMINATED MEDIUM

by

Yako Benveniste

Department of Solid Mechanics, Materials
and Structures
School of Engineering
Tel-Aviv University
Tel-Aviv, Israel.

DDC
RECEIVED
JAN 8 1977
C

The research reported in this document has been supported by the AIR FORCE,
OFFICE OF SCIENTIFIC RESEARCH under Grant 76-3014, through the European Office
of Aerospace Research, (EOAR), United States Air Force.

Approved for public release;
distribution unlimited.

AFOSR - 78 - 76 - 1246

15

AFOSR - 78 - 76 - 1246

Scientific Report No. 1
AFOSR-78-76-1246

06833070A

CONTINUUM MECHANICS FOR CRYSTALLINE
POLYMERIZATION IN A LIMITED REGION

John Bevan

Department of Solid Mechanics, University of Cambridge

1978
School of Mathematics
University of Cambridge
Cambridge, England

RECEIVED
AFOSR
15 JUL 1978

AIR FORCE OFFICE OF SCIENTIFIC RESEARCH (AFOSR)
NOTICE OF TRANSMITTAL TO DDC
This technical report has been reviewed and is
approved for public release IAW AFR 190-12 (7b)
Distribution is unlimited.
A. D. BLOSE
Technical Information Officer

Approved for public release
Distribution unlimited

REPORT DOCUMENTATION PAGE		FORM INSTRUCTIONS SEE COMPLETING FORM RECIPIENT'S CATALOG NUMBER
(18) AFOSR	TR-76-1246	
(9) CONTINUUM THEORIES FOR CYLINDRICAL WAVE PROPAGATION IN A LAMINATED MEDIUM.		(9) INTERIM rept.
7. AUTHOR(s) YAKO/BENVENISTE		5. PERFORMING ORG. REPORT NUMBER Rept No 1 / TAU/SOE 229/76 6. CONTRACT OR GRANT NUMBER(s)
9. PERFORMING ORGANIZATION NAME AND ADDRESS TEL-AVIV UNIVERSITY / SCHOOL OF ENGINEERING SOLID MECHANICS, MATERIALS & STRUCTURES DEPARTMENT TEL-AVIV, ISRAEL	10. PROGRAM ELEMENT, PROJECT, TASK AREA & WORK UNIT NUMBERS 681307 (16) 9782-04 (17) 04 61102F	
11. CONTROLLING OFFICE NAME AND ADDRESS AIR FORCE OFFICE OF SCIENTIFIC RESEARCH/NA BLDG 410 BOLLING AIR FORCE BASE, D C 20332	12. REPORT DATE (11) July 1976	
14. MONITORING AGENCY NAME & ADDRESS (if different from Controlling Office) (14) TAU-SOE/229-76, Scientific-1	13. NUMBER OF PAGES 22 (12) 24 p.	15. SECURITY CLASSIFICATION UNCLASSIFIED
16. DISTRIBUTION STATEMENT (of this Report) Approved for public release; distribution unlimited.		15a. DECLASSIFICATION/DOWNGRADING SCHEDULE
17. DISTRIBUTION STATEMENT (of the abstract entered in Block 20, if different from Report)		
18. SUPPLEMENTARY NOTES		
19. KEY WORDS (Continue on reverse side if necessary and identify by block number) WAVE PROPAGATION COMPOSITE MATERIALS MIXTURE THEORIES MICROSTRUCTURE THEORIES LAMINATED COMPOSITES		
20. ABSTRACT (Continue on reverse side if necessary and identify by block number) In this report, interacting continuum theories are developed for cylindrical wave propagation in a bi-laminated, linearly elastic, composite medium. We consider a cylindrical circular infinite cavity perpendicular to the layering of the composite. The laminated medium is subjected at the cavity wall to a non-axisymmetric shear and normal loading uniform in the direction of the cavity axis. Two microstructure theories are developed; the first simulates the effectively two-dimensional plane motion of the medium which is due to a normal and shear loading in the circumferential direction; the second models the		

du

UNCLASSIFIED

SECURITY CLASSIFICATION OF THIS PAGE(When Data Entered)

→ effectively anti-plane motion due to a shear loading in the direction of the cavity's axis.

UNCLASSIFIED

SECURITY CLASSIFICATION OF THIS PAGE(When Data Entered)

CONTINUUM THEORIES FOR CYLINDRICAL
WAVE PROPAGATION IN A LAMINATED MEDIUM

by

Yako Benveniste

Department of Solid Mechanics, Materials & Structures

School of Engineering

Tel-Aviv University

Tel-Aviv, Israel.

Abstract

In this report, interacting continuum theories are developed for cylindrical wave propagation in a bi-laminated, linearly elastic, composite medium. We consider a cylindrical circular infinite cavity perpendicular to the layering of the composite. The laminated medium is subjected at the cavity wall to a non-axisymmetric shear and normal loading uniform in the direction of the cavity axis. Two microstructure theories are developed: the first simulates the effectively two-dimensional plane motion of the medium which is due to a normal and shear loading in the circumferential direction; the second models the effectively anti-plane motion due to a shear loading in the direction of the cavity's axis.

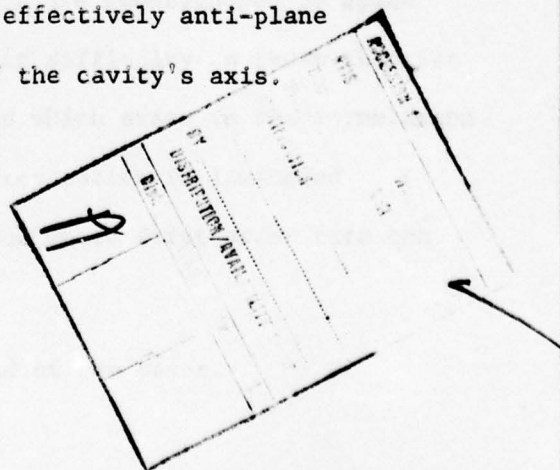

1. Introduction

The investigation of wave propagation in a composite medium is usually carried out by constructing a model of the composite which describes in some sense its gross mechanical response. Such an approach is unavoidable since an "exact" description of the mechanical response of the composite is almost impossible due to the complex geometry and the multiple reflections that waves undergo at the interfaces of its constituents. The simplest model of a composite medium is the so-called "effective modulus theory" which replaces the composite by an equivalent homogeneous anisotropic material with equivalent elastic constants and describes the gross mechanical behavior in terms of the averages of displacements, stresses and strains over the representative elements. The effective modulus theory, however, is not able to account for a very important phenomenon in the propagation of waves in composites, that is, dispersion and attenuation.

A more realistic description of the mechanical behavior of composite media can be attained by taking into consideration in some sense its microstructure. Several such models exist now in the literature and recent review papers by Achenbach [1]^{*} and Moon [2] cover the majority of the research works carried out in this area.

One approach to model a composite by taking into account the microstructure is to use mixture theories as models of composites as suggested by Lempriere [3]. These are interacting continuum theories where the constituents are superimposed in space but allowed to undergo individual deformations. The basic difficulty in these theories is the analytical specification of the interaction terms which arise in the formulation. For the specific case of longitudinal wave-guide type propagation in laminated composites, Hegemier et. al. [4] use an asymptotic method whose first order term can

* Numbers in the brackets designate references at the end of the paper.

be cast in the form of a binary mixture theory, and give a rational construction of both mixture interaction and constitutive relations. By comparison with exact and approximate phase velocity data, they show that the developed theory gives good first mode agreement for wavelengths greater than the typical composite micro-dimension. Furthermore, good correlation with experimental data in transient wave propagation is reported in [4]. The validity of this theory in transient wave propagation was also checked by Aboudi [5] by comparing results with those obtained by solving the complete dynamic equations of elasticity [6]. In [7] Nayfeh and Gurtman extended the theory to study shear waves in laminated wave guides. Again, very satisfactory results are obtained by comparing the dispersion relations with exact phase velocity spectra for the lowest mode of propagation. The theories developed in [4] and [7] are effectively one-dimensional in the sense that the mixture variables are dependent on one space variable only.

In this paper continuum microstructure theories of the type given in [4] and [7] are developed for the case of two-dimensional wave propagation from a cylindrical cavity in a bi-laminated medium. We consider a cylindrical circular infinite cavity perpendicular to the layering of the composite and define a cylindrical coordinate system (r, θ, z) with z being along the axis of the cavity (See Fig. 1). Continuum mixture theories will be developed for two loading situations at the cavity wall: a) Situations in which the loading is tangential in the θ -direction, and/or normal to the cavity, with dependence on θ , but uniform in the z direction, and b) Situations in which the loading is tangential in the z -direction with dependence on θ but again uniform in the z -direction. Clearly, a specific example of a θ -dependent and z -independent loading is an infinite line load in the z -direction. Symmetry considerations show that case (a) yields symmetric $u_r^{(\alpha)}$ and $u_\theta^{(\alpha)}$ and anti-symmetric $u_z^{(\alpha)}$ displacements with respect to the midplanes of each layer, whereas (b) yields anti-symmetric $u_r^{(\alpha)}$ & $u_\theta^{(\alpha)}$ and

symmetric $u_z^{(\alpha)}$ displacements again with respect to the midplanes.* It is clear that when the displacements are averaged over a layer no net $u_z^{(\alpha)}$ displacements are obtained in case (a) and no net $u_r^{(\alpha)}$ and $u_\theta^{(\alpha)}$ displacements in case (b). Therefore we will characterize the motion in (a) by the name quasi-plane motion and that in (b) by the name quasi-anti-plane motion. Note that both motions are two-dimensional. For the specific situations in which the loading at the cavity wall is axi-symmetric, three cases are distinguished: (1) Axi-symmetric normal loading at the cavity wall; in this case there are no $u_\theta^{(\alpha)}$ displacements and the $u_r^{(\alpha)}$ and $u_z^{(\alpha)}$ displacements are respectively symmetric and anti-symmetric with respect to the midplanes. Since, on the average the $u_z^{(\alpha)}$ displacements vanish, this motion can be characterized as quasi-radial motion. (2) Axi-symmetric tangential loading in the θ -direction at the cavity wall; in this case there are no $u_r^{(\alpha)}$ displacements and the $u_\theta^{(\alpha)}$ and $u_z^{(\alpha)}$ are respectively symmetric and anti-symmetric with respect to the midplanes. The motion is characterized as quasi-rotatory motion. Note that cases (1) and (2) are special cases of the quasi-plane motion. (3) Axi-symmetric tangential loading in the z -direction; the motion caused by this kind of loading is a special case of the quasi-anti-plane motion which does not have any θ -dependence.

In the second section of this paper, the equations of motion and constitutive equations for each constituent will be given. In the third and fourth sections, continuum microstructure theories will be developed for the quasi-plane and quasi-anti-plane motion respectively.

* Here and in the sequel the superscript or the subscript α will take the values 1 or 2 and will indicate that the quantities belong to either one of the constituents.

2. Basic Equations

Consider a periodic array of two alternating isotropic linearly elastic layers of widths $2h_1$ and $2h_2$ respectively. Let us also consider an infinite circular cylindrical cavity perpendicular to the layering. Define a cylindrical coordinate system (r, θ, z) such that the z coordinate is along the axis of the cylindrical cavity. Furthermore, let z_α be a local coordinate measured from the midplane of each layer (See Fig. 1).

The equations of motion and the constitutive equations in cylindrical coordinates for every individual layer, are given by :

$$\frac{\partial}{\partial r} \sigma_{rr}^{(\alpha)} + (1/r) \frac{\partial}{\partial \theta} \sigma_{r\theta}^{(\alpha)} + \frac{\partial}{\partial z_\alpha} \sigma_{rz}^{(\alpha)} + [(\sigma_{rr}^{(\alpha)} - \sigma_{\theta\theta}^{(\alpha)}) / r] = \rho_\alpha \frac{\partial^2}{\partial t^2} u_r^{(\alpha)} \quad (2.1)$$

$$\frac{\partial}{\partial r} \sigma_{r\theta}^{(\alpha)} + (1/r) \frac{\partial}{\partial \theta} \sigma_{\theta\theta}^{(\alpha)} + \frac{\partial}{\partial z_\alpha} \sigma_{\theta z}^{(\alpha)} + (2\sigma_{r\theta}^{(\alpha)} / r) = \rho_\alpha \frac{\partial^2}{\partial t^2} u_\theta^{(\alpha)} \quad (2.2)$$

$$\frac{\partial}{\partial r} \sigma_{rz}^{(\alpha)} + (1/r) \frac{\partial}{\partial \theta} \sigma_{\theta z}^{(\alpha)} + \frac{\partial}{\partial z_\alpha} \sigma_{zz}^{(\alpha)} + (\sigma_{rz}^{(\alpha)} / r) = \rho_\alpha \frac{\partial^2}{\partial t^2} u_z^{(\alpha)} \quad (2.3)$$

$$\sigma_{rr}^{(\alpha)} = \lambda_\alpha \Delta^{(\alpha)} + 2\mu_\alpha \left(\frac{\partial}{\partial r} u_r^{(\alpha)} \right) \quad (2.4)$$

$$\sigma_{\theta\theta}^{(\alpha)} = \lambda_\alpha \Delta^{(\alpha)} + 2\mu_\alpha \left(\frac{\partial}{\partial \theta} u_\theta^{(\alpha)} + u_r^{(\alpha)} / r \right) \quad (2.5)$$

$$\sigma_{zz}^{(\alpha)} = \lambda_\alpha \Delta^{(\alpha)} + 2\mu_\alpha \left(\frac{\partial}{\partial z_\alpha} u_z^{(\alpha)} \right) \quad (2.6)$$

$$\sigma_{r\theta}^{(\alpha)} = \mu_\alpha \left[(1/r) \frac{\partial}{\partial \theta} u_r^{(\alpha)} + \frac{\partial}{\partial r} u_\theta^{(\alpha)} - (u_\theta^{(\alpha)} / r) \right] \quad (2.7)$$

$$\sigma_{rz}^{(\alpha)} = \mu_\alpha \left(\frac{\partial}{\partial r} u_z^{(\alpha)} + \frac{\partial}{\partial z_\alpha} u_r^{(\alpha)} \right) \quad (2.8)$$

$$\sigma_{\theta z}^{(\alpha)} = \mu_\alpha \left[\frac{\partial}{\partial z_\alpha} u_\theta^{(\alpha)} + (1/r) \frac{\partial}{\partial \theta} u_z^{(\alpha)} \right] \quad (2.9)$$

where

$$\Delta^{(\alpha)} = \frac{\partial}{\partial r} u_r^{(\alpha)} + \left[\left(\frac{\partial}{\partial \theta} u_\theta^{(\alpha)} + u_r^{(\alpha)} \right) / r \right] + \frac{\partial}{\partial z_\alpha} u_z^{(\alpha)} \quad (2.10)$$

and $\sigma_{ij}^{(\alpha)}$ and $u_j^{(\alpha)}$ with i and j standing for r, θ, z are the stresses and displacements, ρ_α is the density of each constituent, λ_α and μ_α are the Lamé parameters and t denotes the time.

3. Quasi-plane Motion

In this section, we will consider situations in which the $u_z^{(\alpha)}$ displacements are anti-symmetric and the $u_r^{(\alpha)}$ and $u_\theta^{(\alpha)}$ displacements symmetric with respect to the midplanes of the layers. The general case of a θ -dependent normal, and shear loading in the θ -direction at the cavity wall will be treated and a continuum mixture theory will be developed which will model the composite in this two-dimensional quasi-plane motion. At the end of the section, the special case of axi-symmetric wave propagation will be briefly discussed.

To develop the microstructure model the equations of motion (2.1) and (2.2) will be averaged over the z_α coordinates and after defining "partial stresses" and "partial densities" they will be cast in a standard binary mixture form. A similar averaging process will be carried out for the constitutive equations (2.4), (2.5) and (2.7) and approximate constitutive relations connecting the partial stresses to the average constituent displacements will be obtained.

We define the average quantity

$$\bar{\psi}^{(\alpha)}(r, \theta, t) = (1/h_\alpha) \int_0^{h_\alpha} \psi^{(\alpha)}(r, \theta, z_\alpha, t) dz_\alpha \quad (3.1)$$

and the partial stress and densities as:

$$\begin{aligned} \sigma_{r\theta}^{(\alpha p)} &= n_\alpha \bar{\sigma}_{r\theta}^{(\alpha)} \\ \sigma_{rr}^{(\alpha p)} &= n_\alpha \bar{\sigma}_{rr}^{(\alpha)} \\ \sigma_{\theta\theta}^{(\alpha p)} &= n_\alpha \bar{\sigma}_{\theta\theta}^{(\alpha)} \\ \rho_\alpha^{(p)} &= n_\alpha \rho_\alpha \end{aligned} \tag{3.2}$$

where

$$n_\alpha = h_\alpha/h, \text{ with } h = h_1 + h_2. \tag{3.3}$$

Note that the symmetry of the $u_r^{(\alpha)}$ and $u_\theta^{(\alpha)}$ and the anti-symmetry of $u_z^{(\alpha)}$ displacements imply symmetry with respect to the midplanes of the $\sigma_{rr}^{(\alpha)}$, $\sigma_{\theta\theta}^{(\alpha)}$, $\sigma_{zz}^{(\alpha)}$, $\sigma_{r\theta}^{(\alpha)}$ stresses and anti-symmetry of $\sigma_{\theta z}^{(\alpha)}$ and $\sigma_{rz}^{(\alpha)}$. We now take the average of equations (2.1) and (2.2), and employing the stated anti-symmetry and continuity conditions of the $\sigma_{rz}^{(\alpha)}$ and $\sigma_{\theta z}^{(\alpha)}$ stresses at the interfaces we obtain the following mixture equations of motion:

$$\begin{aligned} \frac{\partial}{\partial r} \sigma_{rr}^{(\alpha p)} + (1/r) \frac{\partial}{\partial \theta} \sigma_{r\theta}^{(\alpha p)} + [(\sigma_{rr}^{(\alpha p)} - \sigma_{\theta\theta}^{(\alpha p)})/r] - \rho_\alpha^{(p)} \frac{\partial^2}{\partial t^2} \bar{u}_r^{(\alpha)} = \\ = q_\alpha Q(r, \theta, t) \end{aligned} \tag{3.4}$$

$$\frac{\partial}{\partial r} \sigma_{r\theta}^{(\alpha p)} + (1/r) \frac{\partial}{\partial \theta} \sigma_{\theta\theta}^{(\alpha p)} + (2\sigma_{r\theta}^{(\alpha p)})/r - \rho_\alpha^{(p)} \frac{\partial^2}{\partial t^2} \bar{u}_\theta^{(\alpha)} = q_\alpha P(r, \theta, t) \tag{3.5}$$

where

$$[Q(r, \theta, t)](h) = \sigma_{rz}^{(2)}(r, \theta, h_2, t) = \sigma_{rz}^{(1)}(r, \theta, -h_1, t) = -\sigma_{rz}^{(1)}(r, \theta, h_1, t) \quad (3.6)$$

$$[P(r, \theta, t)](h) = \sigma_{\theta z}^{(2)}(r, \theta, h_2, t) = \sigma_{\theta z}^{(1)}(r, \theta, -h_1, t) = -\sigma_{\theta z}^{(1)}(r, \theta, h_1, t) \quad (3.7)$$

and

$$q_1 = 1 \quad q_2 = -1 \quad \dagger$$

We will call the partial stresses $\sigma_{rr}^{(\alpha p)}$, $\sigma_{\theta\theta}^{(\alpha p)}$, $\sigma_{r\theta}^{(\alpha p)}$ and the average displacements $\bar{u}_r^{(\alpha)}$, $\bar{u}_\theta^{(\alpha)}$ by the term mixture variables. The next step is to develop approximate constitutive equations relating the partial stresses to the average constituent displacements. Furthermore, expressions relating P and Q to the mixture variables will be obtained. These expressions will be based on the assumption that for a characteristic wave length L , and composite microdimension $h = h_1 + h_2$, the ratio $\epsilon = h/L$ is a small parameter and terms of order ϵ^2 can be neglected (see [4]).

Averaging equations (3.4 - 3.7) according to (3.1) and using the anti-symmetry and continuity properties of $u_z^{(\alpha)}$ we obtain:

$$[(\bar{\sigma}_{rr}^{(\alpha)}/\lambda_\alpha) - (E_\alpha/\lambda_\alpha) \frac{\partial}{\partial r} \bar{u}_r^{(\alpha)} - (1/r) (\frac{\partial}{\partial \theta} \bar{u}_\theta^{(\alpha)} - \bar{u}_r^{(\alpha)})] n_\alpha = -q_\alpha S(r, \theta, t) \quad (3.8)$$

$$[(\bar{\sigma}_{\theta\theta}^{(\alpha)}/\lambda_\alpha) - (E_\alpha/\lambda_\alpha) (1/r) (\frac{\partial}{\partial \theta} \bar{u}_\theta^{(\alpha)} + \bar{u}_r^{(\alpha)}) - \frac{\partial}{\partial r} \bar{u}_r^{(\alpha)}] n_\alpha = -q_\alpha S(r, \theta, t) \quad (3.9)$$

$$[(\bar{\sigma}_{zz}^{(\alpha)}/E_\alpha) - (\lambda_\alpha/E_\alpha) \frac{\partial}{\partial r} \bar{u}_r^{(\alpha)} - (\lambda_\alpha/E_\alpha) (1/r) (\frac{\partial}{\partial \theta} \bar{u}_\theta^{(\alpha)} + \bar{u}_r^{(\alpha)})] n_\alpha = -q_\alpha S(r, \theta, t) \quad (3.10)$$

$$\sigma_{r\theta}^{(\alpha p)} = n_\alpha \mu_\alpha [(1/r) (\frac{\partial}{\partial \theta} \bar{u}_r^{(\alpha)} - \bar{u}_\theta^{(\alpha)}) + \frac{\partial}{\partial r} \bar{u}_\theta^{(\alpha)}] \quad (3.11)$$

† In order to abbreviate the equations, this notation will be used in the sequel too.

$$[Q(r, \theta, t)](h) = \sigma_{rz}^{(2)}(r, \theta, h_2, t) = \sigma_{rz}^{(1)}(r, \theta, -h_1, t) = -\sigma_{rz}^{(1)}(r, \theta, h_1, t) \quad (3.6)$$

$$[P(r, \theta, t)](h) = \sigma_{\theta z}^{(2)}(r, \theta, h_2, t) = \sigma_{\theta z}^{(1)}(r, \theta, -h_1, t) = -\sigma_{\theta z}^{(1)}(r, \theta, h_1, t) \quad (3.7)$$

and

$$q_1 = 1 \quad q_2 = -1 \quad .$$

We will call the partial stresses $\sigma_{rr}^{(\alpha p)}$, $\sigma_{\theta\theta}^{(\alpha p)}$, $\sigma_{r\theta}^{(\alpha p)}$ and the average displacements $\bar{u}_r^{(\alpha)}$, $\bar{u}_\theta^{(\alpha)}$ by the term mixture variables. The next step is to develop approximate constitutive equations relating the partial stresses to the average constituent displacements. Furthermore, expressions relating P and Q to the mixture variables will be obtained. These expressions will be based on the assumption that for a characteristic wave length L, and composite microdimension $h = h_1 + h_2$, the ratio $\epsilon = h/L$ is a small parameter and terms of order ϵ^2 can be neglected (see [4]).

Averaging equations (3.4 - 3.7) according to (3.1) and using the anti-symmetry and continuity properties of $u_z^{(\alpha)}$ we obtain:

$$[(\bar{\sigma}_{rr}^{(\alpha)}/\lambda_\alpha) - (E_\alpha/\lambda_\alpha) \frac{\partial}{\partial r} \bar{u}_r^{(\alpha)} - (1/r) (\frac{\partial}{\partial \theta} \bar{u}_\theta^{(\alpha)} - \bar{u}_r^{(\alpha)})] n_\alpha = -q_\alpha S(r, \theta, t) \quad (3.8)$$

$$[(\bar{\sigma}_{\theta\theta}^{(\alpha)}/\lambda_\alpha) - (E_\alpha/\lambda_\alpha) (1/r) (\frac{\partial}{\partial \theta} \bar{u}_\theta^{(\alpha)} + \bar{u}_r^{(\alpha)}) - \frac{\partial}{\partial r} \bar{u}_r^{(\alpha)}] n_\alpha = -q_\alpha S(r, \theta, t) \quad (3.9)$$

$$[(\bar{\sigma}_{zz}^{(\alpha)}/E_\alpha) - (\lambda_\alpha/E_\alpha) \frac{\partial}{\partial r} \bar{u}_r^{(\alpha)} - (\lambda_\alpha/E_\alpha) (1/r) (\frac{\partial}{\partial \theta} \bar{u}_\theta^{(\alpha)} + \bar{u}_r^{(\alpha)})] n_\alpha = -q_\alpha S(r, \theta, t) \quad (3.10)$$

$$\sigma_{r\theta}^{(\alpha p)} = n_\alpha \mu_\alpha [(1/r) (\frac{\partial}{\partial \theta} \bar{u}_r^{(\alpha)} - \bar{u}_\theta^{(\alpha)}) + \frac{\partial}{\partial r} \bar{u}_\theta^{(\alpha)}] \quad (3.11)$$

† In order to abbreviate the equations, this notation will be used in the sequel too.

where

$$E_{\alpha} = \lambda_{\alpha} + 2\mu_{\alpha} , \quad (3.12)$$

and

$$(h)[S(r,\theta,t)] = u_z^{(2)}(r,\theta,h_2,t) = u_z^{(1)}(r,\theta,-h_1,t) = -u_z^{(1)}(r,\theta,h_1,t). \quad (3.13)$$

We will now obtain an approximate expression for S , which, when substituted in (3.8) and (3.9) will give together with (3.11) the desired mixture constitutive equations. For this purpose we expand $u_r^{(\alpha)}$, $u_{\theta}^{(\alpha)}$ and $u_z^{(\alpha)}$ in terms of z_{α} while utilizing their symmetry properties. Using then these expressions in (2.6) an expansion for $\sigma_{zz}^{(\alpha)}$ is obtained (See [4]). This is of the form:

$$\sigma_{zz}^{(\alpha)} = \bar{\sigma}_{zz}^{(\alpha)} [1 + O(\epsilon^2)] \quad (3.14)$$

Using the continuity of $\sigma_{zz}^{(\alpha)}$ across the interfaces, up to the order of approximation we are concerned with in this paper, we can write:

$$\bar{\sigma}_{zz}^{(1)} \approx \bar{\sigma}_{zz}^{(2)} \quad (3.15)$$

Equation (3.15) together with (3.10) furnishes an expression for S :

$$\begin{aligned} S(r,\theta,t) = & (\lambda_1/E) \left[\frac{\partial}{\partial r} \bar{u}_r^{(1)} + (1/r)(\bar{u}_r^{(1)} + \frac{\partial}{\partial \theta} \bar{u}_{\theta}^{(1)}) \right] - \\ & - (\lambda_2/E) \left[\frac{\partial}{\partial r} \bar{u}_r^{(2)} + (1/r)(\bar{u}_r^{(2)} + \frac{\partial}{\partial \theta} \bar{u}_{\theta}^{(2)}) \right] \quad (3.16) \end{aligned}$$

where

$$E = (E_2/n_2) + (E_1/n_1)$$

Substituting (3.16) in (3.8) and (3.9) we obtain

$$\begin{aligned} \sigma_{rr}^{(1p)} = & c_{11} \frac{\partial}{\partial r} \bar{u}_r^{(1)} + c_{12} \left[\frac{\partial}{\partial r} \bar{u}_r^{(2)} + (1/r) \left(\frac{\partial}{\partial \theta} \bar{u}_\theta^{(2)} + \bar{u}_r^{(2)} \right) \right] + \\ & + d_1 \left[(1/r) \left(\frac{\partial}{\partial \theta} \bar{u}_\theta^{(1)} + \bar{u}_r^{(1)} \right) \right] \end{aligned} \quad (3.17)$$

$$\begin{aligned} \sigma_{rr}^{(2p)} = & c_{22} \frac{\partial}{\partial r} \bar{u}_r^{(2)} + c_{12} \left[\frac{\partial}{\partial r} \bar{u}_r^{(1)} + (1/r) \left(\frac{\partial}{\partial \theta} \bar{u}_\theta^{(1)} + \bar{u}_r^{(1)} \right) \right] + \\ & + d_2 \left[(1/r) \left(\frac{\partial}{\partial \theta} \bar{u}_\theta^{(2)} + \bar{u}_r^{(2)} \right) \right] \end{aligned} \quad (3.18)$$

$$\begin{aligned} \sigma_{\theta\theta}^{(1p)} = & c_{11} \left[(1/r) \left(\frac{\partial}{\partial \theta} \bar{u}_\theta^{(1)} + \bar{u}_r^{(1)} \right) \right] + c_{12} \left[\frac{\partial}{\partial r} \bar{u}_r^{(2)} + (1/r) \left(\frac{\partial}{\partial \theta} \bar{u}_\theta^{(2)} + \bar{u}_r^{(2)} \right) \right] + \\ & + d_1 \frac{\partial}{\partial r} \bar{u}_r^{(1)} \end{aligned} \quad (3.19)$$

$$\begin{aligned} \sigma_{\theta\theta}^{(2p)} = & c_{22} \left[(1/r) \left(\frac{\partial}{\partial \theta} \bar{u}_\theta^{(2)} + \bar{u}_r^{(2)} \right) \right] + c_{12} \left[\frac{\partial}{\partial r} \bar{u}_r^{(1)} + (1/r) \left(\frac{\partial}{\partial \theta} \bar{u}_\theta^{(1)} + \bar{u}_r^{(1)} \right) \right] + \\ & + d_2 \frac{\partial}{\partial r} \bar{u}_r^{(2)} \end{aligned} \quad (3.20)$$

where

$$\left. \begin{aligned} c_{\alpha\alpha} &= [n_\alpha E_\alpha - (\lambda_\alpha^2 / E)] \\ c_{\alpha\beta} &= \lambda_\alpha \lambda_\beta / E \\ d_\alpha &= [n_\alpha \lambda_\alpha - (\lambda_\alpha^2 / E)] \end{aligned} \right\} \quad (3.21)$$

with $\alpha, \beta = 1, 2$ and $\alpha \neq \beta$.

Equations (3.11) and (3.17-3.20) are the desired mixture constitutive equations. It remains now to derive expressions relating Q and P to the mixture variables. Let us first obtain the expression for Q . Again the procedure followed in [4] will be used here and it will be given briefly without details. Multiplying equation (2.8) by z_α , expanding in powers of z_α and integrating by parts we obtain:

$$u_r^{(\alpha)}(r, \theta, h_\alpha, t) - \bar{u}_r^{(\alpha)} + (h_\alpha/3) \left[\frac{\partial}{\partial r} u_z^{(\alpha)}(r, \theta, h_\alpha, t) - (1/\mu_\alpha) u_{rz}^{(\alpha)}(r, \theta, h_\alpha, t) \right] = 0 \quad (3.22)$$

Using the definitions (3.6) and (3.13) gives:

$$u_r^{(1)}(r, \theta, h_1, t) - \bar{u}_r^{(1)} + (h_1/3) \left[-\frac{\partial}{\partial r} S + (1/\mu_1) Q \right] = 0 \quad (3.23)$$

$$u_r^{(2)}(r, \theta, h_2, t) - \bar{u}_r^{(2)} + (h_2/3) \left[\frac{\partial}{\partial r} S - (1/\mu_2) Q \right] = 0 \quad (3.24)$$

Subtracting (3.24) from (3.23), employing the continuity condition of $u_r^{(\alpha)}$ across the interfaces, and using equation (3.16), we get:

$$Q(r, \theta, t) = (K/h^2) (\bar{u}_r^{(1)} - \bar{u}_r^{(2)}) + \mathcal{L}_1 \{ M(\lambda_1/E) \bar{u}_r^{(1)} - (\lambda_2/E) \bar{u}_r^{(2)} \} + \mathcal{L}_2 \{ M(\lambda_1/E) \bar{u}_\theta^{(1)} - (\lambda_2/E) \bar{u}_\theta^{(2)} \} \quad (3.25)$$

where

$$K = \left[(n_1/3\mu_1) + (n_2/3\mu_2) \right]^{-1} \quad (3.26)$$

$$M = K/3$$

and \mathcal{L}_1 and \mathcal{L}_2 are differential operators such that

$$\mathcal{L}_1(\psi) = \frac{\partial}{\partial r} \mathcal{L}_0 \psi \quad (3.27)$$

$$\mathcal{L}_0(\psi) = \frac{\partial}{\partial r} \psi + (1/r) \psi \quad (3.28)$$

$$\mathcal{L}_2(\psi) = (1/r) \frac{\partial^2}{\partial r \partial \theta} \psi - (1/r^2) \frac{\partial}{\partial \theta} \psi \quad (3.29)$$

The expression for P can be obtained by applying the same steps, this time to equation (2.9). The result is:

$$P(r, \theta, t) = (K/h^2)(\bar{u}_\theta^{(1)} - \bar{u}_\theta^{(2)}) + [\mathcal{L}_2 + (2/r^2) \frac{\partial}{\partial \theta}] \{M[(\lambda_1/E)\bar{u}_r^{(1)} - (\lambda_2/E)\bar{u}_r^{(2)}]\} \\ + (1/r) \frac{\partial^2}{\partial \theta^2} \{M[(\lambda_1/E)\bar{u}_\theta^{(1)} - (\lambda_2/E)\bar{u}_\theta^{(2)}]\} \quad (3.30)$$

The mixture equations of motion (3.4, 3.5) together with the interaction terms Q and P given by (3.25) and (3.30), and the mixture constitutive equations (3.11, 3.17-3.20) define completely the quasi-plane motion of the laminated medium as modeled by the present microstructure theory. Note that the equations are two-dimensional in r and θ and the tangential displacement $\bar{u}_\theta^{(\alpha)}$ and the radial displacements $\bar{u}_r^{(\alpha)}$ are coupled to each other. Substitution of (3.11, 3.17-3.20, 3.25 and 3.30) in the equations of motion (3.4, 3.5) provides four coupled partial differential equations for $\bar{u}_r^{(1)}$, $\bar{u}_r^{(2)}$, $\bar{u}_\theta^{(1)}$ and $\bar{u}_\theta^{(2)}$; when these are prescribed at the cavity wall, together with initial conditions, they can be determined throughout the laminated medium.

For the special case of axi-symmetric loading at the cavity wall, there is no dependence on θ and inspection of the field equations show that the $\bar{u}_r^{(\alpha)}$ and $\bar{u}_\theta^{(\alpha)}$ displacements decouple each other. In one case there is a net radial motion of the medium and in the other, a net rotatory motion; these are called respectively the quasi-radial and quasi-rotatory motion of the laminated composite.

4. Quasi-anti-plane motion

In the present section we will consider the motion of the composite which is caused by a tangential loading in the z -direction at the cavity wall, this input being uniform in the z -direction but dependent in θ . The motion will be such that the $u_z^{(\alpha)}$ displacements are symmetric with respect to the midplanes whereas the $u_r^{(\alpha)}$ and the $u_\theta^{(\alpha)}$ displacements are anti-symmetric. A net motion in the z -direction will be present which will be two-dimensional in r and θ . As in the previous section we will develop here a continuum microstructure theory modeling the laminated composite in this two-dimensional quasi-anti-plane motion.

First, it is noted that symmetric $u_z^{(\alpha)}$ and anti-symmetric $u_\theta^{(\alpha)}$ and $u_r^{(\alpha)}$ give rise to symmetric $\sigma_{\theta z}^{(\alpha)}$ and $\sigma_{rz}^{(\alpha)}$ and anti-symmetric $\sigma_{rr}^{(\alpha)}$, $\sigma_{\theta\theta}^{(\alpha)}$, $\sigma_{zz}^{(\alpha)}$, $\sigma_{r\theta}^{(\alpha)}$ with respect to the midplanes. Averaging equation (2.3) according to (3.1) and defining again the partial stresses

$$\sigma_{rz}^{(\alpha p)} = n_\alpha \bar{\sigma}_{rz}^{(\alpha)} \quad (4.1)$$

gives

$$\left[\frac{\partial}{\partial r} + (1/r) \right] \sigma_{rz}^{(\alpha p)} + (1/r) \frac{\partial}{\partial \theta} \sigma_{\theta z}^{(\alpha p)} - \sigma_\alpha^{(p)} \frac{\partial^2}{\partial \tau^2} \bar{u}_z^{(\alpha)} = q_\alpha R(r, \theta, t) \quad (4.2)$$

where

$$[R(r, \theta, t)]_h = \sigma_{zz}^{(2)}(r, \theta, h_2, t) = \sigma_{zz}^{(1)}(r, \theta, -h_1, t) = -\sigma_{zz}^{(1)}(r, \theta, h_1, t) \quad (4.3)$$

Averaging equations (2.8) and (2.9) we obtain:

$$\sigma_{rz}^{(\alpha p)} - \mu_\alpha n_\alpha \frac{\partial}{\partial r} \bar{u}_z^{(\alpha)} = q_\alpha \mu_\alpha U(r, \theta, t) \quad (4.4)$$

$$\sigma_{\theta z}^{(\alpha p)} - \mu_\alpha n_\alpha (1/r) \frac{\partial}{\partial \theta} \bar{u}_z^{(\alpha)} = q_\alpha \mu_\alpha T(r, \theta, t) \quad (4.5)$$

where

$$\sigma_{\theta z}^{(\alpha)} = n_\alpha \bar{\sigma}_{\theta z}^{(\alpha)} \quad (4.6)$$

and

$$[U(r, \theta, t)]_h = u_r^{(1)}(r, \theta, h_1, t) = u_r^{(2)}(r, \theta, -h_2, t) = -u_r^{(2)}(r, \theta, h_2, t) \quad (4.7)$$

$$[T(r, \theta, t)]_h = u_\theta^{(1)}(r, \theta, h_1, t) = u_\theta^{(2)}(r, \theta, -h_2, t) = -u_\theta^{(2)}(r, \theta, h_2, t) \quad (4.8)$$

Equations (4.2) are the mixture equations of motion and equations (4.4) and (4.5) the mixture constitutive equations. They contain the functions $R(r, \theta, t)$, $U(r, \theta, t)$ and $T(r, \theta, t)$ which will have to be determined in terms of the mixture variables. The determination of these functions will be carried out by following similar procedures to those given in [7]. In the present case, three coupled differential equations will be obtained for R , U and T .

Multiplying equations (2.6) by z_α , expanding $u_r^{(\alpha)}$ and $\sigma_{zz}^{(\alpha)}$ in powers of z_α and then integrating by parts give (See [7]):

$$E_\alpha [u_z^{(\alpha)}(r, \theta, h_\alpha, t) - \bar{u}_z^{(\alpha)}] = (h_\alpha/3) \{ \sigma_{zz}^{(\alpha)}(r, \theta, h_\alpha, t) - \lambda_\alpha [\frac{\partial}{\partial r} u_r^{(\alpha)}(r, \theta, h_\alpha, t) + (1/r) u_r^{(\alpha)}(r, \theta, h_\alpha, t) + (1/r) \frac{\partial}{\partial \theta} u_\theta^{(\alpha)}(r, \theta, h_\alpha, t)] \} \quad (4.9)$$

Using the definitions (4.3), (4.7) and (4.8) results in:

$$u_z^{(1)}(r, \theta, h_1, t) - \bar{u}_z^{(1)} = (h_1 h / 3 E_1) \{ -R - \lambda_1 \mathcal{L}_0 U - \lambda_1 (1/r) \frac{\partial}{\partial \theta} T \} \quad (4.10)$$

$$u_z^{(2)}(r, \theta, h_2, t) - \bar{u}_z^{(2)} = (h_2 h / 3 E_2) \{ R + \lambda_2 \mathcal{L}_0 U + \lambda_2 (1/r) \frac{\partial}{\partial \theta} T \} \quad (4.11)$$

Subtracting (4.11) from (4.10), employing the continuity condition of $u_z^{(\alpha)}$ across the interfaces, we get:

$$a_1 \mathcal{L}_0 U(r, \theta, t) + a_1 (1/r) \frac{\partial}{\partial \theta} T(r, \theta, t) + a_2 R(r, \theta, t) + [(\bar{u}_z^{(2)} - \bar{u}_z^{(1)}) / h^2] = 0 \quad (4.12)$$

where

$$a_1 = [(\lambda_1 n_1 / E_1) + (\lambda_2 n_2 / E_2)] / 3 \quad (4.13)$$

$$a_2 = [(n_1 / E_1) + (n_2 / E_2)] / 3 \quad (4.14)$$

Equation (4.12) is the first differential equation relating U, R and T to $\bar{u}_z^{(\alpha)}$.

Substitution of (2.4), (2.5) and (2.7) in (2.1) gives:

$$\mathcal{L}_3^{(\alpha)} u_r^{(\alpha)} + \mathcal{L}_4^{(\alpha)} u_\theta^{(\alpha)} + \frac{\partial}{\partial z_\alpha} \sigma_{rz}^{(\alpha)} + \lambda_\alpha \frac{\partial^2}{\partial r \partial z_\alpha} u_z^{(\alpha)} = 0 \quad (4.15)$$

where $\mathcal{L}_3^{(\alpha)}$ and $\mathcal{L}_4^{(\alpha)}$ are differential operators such that,

$$\mathcal{L}_3^{(\alpha)} \psi = E_\alpha \mathcal{L}_1(\psi) + (\mu_\alpha/r^2) \frac{\partial^2}{\partial \theta^2} \psi - \rho_\alpha \frac{\partial^2}{\partial t^2} \psi \quad (4.16)$$

$$\mathcal{L}_4^{(\alpha)} \psi = (\lambda_\alpha + \mu_\alpha) \mathcal{L}_2(\psi) - (2\mu_\alpha/r^2) \frac{\partial}{\partial \theta} \psi \quad (4.17)$$

Multiplying equation (4.15) by z_α , expanding $u_r^{(\alpha)}$ and $u_\theta^{(\alpha)}$ in powers of z_α and integrating by parts, we obtain:

$$\begin{aligned} (h_\alpha/3) [\mathcal{L}_3^{(\alpha)} u_r^{(\alpha)}(r, \theta, h_\alpha, t) + \mathcal{L}_4^{(\alpha)} u_\theta^{(\alpha)}(r, \theta, h_\alpha, t)] + \\ + \lambda_\alpha \frac{\partial}{\partial r} [u_z^{(\alpha)}(r, \theta, h_\alpha, t) - \bar{u}_z^{(\alpha)}] + [\sigma_{rz}^{(\alpha)}(r, \theta, h_\alpha, t) - \bar{\sigma}_{rz}^{(\alpha)}] = 0 \quad (4.18) \end{aligned}$$

Substitution of (4.9) in (4.18) furnishes:

$$\begin{aligned} \{(n_\alpha/3) \mathcal{L}_5^{(\alpha)} [u_r^{(\alpha)}(r, \theta, h_\alpha, t)/h]\} + \{(n_\alpha/3) \mathcal{L}_6^{(\alpha)} [u_\theta^{(\alpha)}(r, \theta, h_\alpha, t)/h]\} \\ + \{(\lambda_\alpha n_\alpha/3E_\alpha) \frac{\partial}{\partial r} [\sigma_{zz}^{(\alpha)}(r, \theta, h_\alpha, t)/h]\} + \{[\sigma_{rz}^{(\alpha)}(r, \theta, h_\alpha, t) - \bar{\sigma}_{rz}^{(\alpha)}]/h^2\} = 0 \quad (4.19) \end{aligned}$$

where

$$\mathcal{L}_5^{(\alpha)} \psi = [E_\alpha - (\lambda_\alpha^2/E_\alpha)] \mathcal{L}_1 \psi + [(\mu_\alpha/r^2) \frac{\partial^2}{\partial \theta^2} \psi] - \rho_\alpha \frac{\partial^2}{\partial t^2} \psi \quad (4.20)$$

$$\mathcal{L}_6^{(\alpha)} \psi = [(\lambda_\alpha + \mu_\alpha) - (\lambda_\alpha^2/E_\alpha)] \mathcal{L}_2 \psi - (2\mu_\alpha/r^2) \frac{\partial}{\partial \theta} \psi \quad (4.21)$$

Introduction of the definitions (4.3), (4.7) and (4.8) in (4.19) provides:

$$\begin{aligned} [(n_1/3) \mathcal{L}_5^{(1)} U] + [(n_1/3) \mathcal{L}_6^{(1)} T] - [(\lambda_1 n_1/3E_1) \frac{\partial}{\partial r} R] + \\ + \{[\sigma_{rz}^{(1)}(r, \theta, h_1, t) - \bar{\sigma}_{rz}^{(1)}]/h^2\} = 0 \quad (4.22) \end{aligned}$$

$$\begin{aligned} -[(n_2/3) \mathcal{L}_5^{(2)} U] - [(n_2/3) \mathcal{L}_6^{(2)} T] + [(\lambda_2 n_2/3E_2) \frac{\partial}{\partial r} R] + \\ + \{[\sigma_{rz}^{(2)}(r, \theta, h_2, t) - \bar{\sigma}_{rz}^{(2)}]/h^2\} = 0 \quad (4.23) \end{aligned}$$

which, when subtracted from each other finally yields:

$$\mathcal{L}_7 U(r, \theta, t) + \mathcal{L}_8 T(r, \theta, t) - a_1 \frac{\partial}{\partial r} R(r, \theta, t) + [(\sigma_{rz}^{(2p)}/n_2) - (\sigma_{rz}^{(1p)}/n_1)]/h^2 = 0 \quad (4.24)$$

where

$$\mathcal{L}_7 \psi = [(n_1/3) \mathcal{L}_5^{(1)} \psi + (n_2/3) \mathcal{L}_5^{(2)} \psi] \quad (4.25)$$

$$\mathcal{L}_8 \psi = [(n_1/3) \mathcal{L}_6^{(1)} \psi + (n_2/3) \mathcal{L}_6^{(2)} \psi] \quad (4.26)$$

Equation (4.24) is the second differential equation relating U, T and R.

It remains now to derive the third and last differential equation for these functions. We start first by substituting (2.7) and (2.5) in (2.2), which provides:

$$\mathcal{L}_9^{(\alpha)} u_\theta^{(\alpha)} + \mathcal{L}_{10}^{(\alpha)} u_r^{(\alpha)} + [(1/r) \lambda_\alpha \frac{\partial^2}{\partial z_\alpha \partial \theta} u_z^{(\alpha)}] + \frac{\partial}{\partial z_\alpha} \sigma_{\theta z}^{(\alpha)} = 0 \quad (4.27)$$

where

$$\mathcal{L}_9^{(\alpha)} \psi = E_\alpha (1/r^2) \frac{\partial^2}{\partial \theta^2} \psi + \mu_\alpha \mathcal{L}_1 \psi - \rho_\alpha \frac{\partial^2}{\partial t^2} \psi \quad (4.28)$$

$$\mathcal{L}_{10}^{(\alpha)} \psi = 2E_\alpha (1/r^2) \frac{\partial}{\partial \theta} \psi + (\lambda_\alpha + \mu_\alpha) \mathcal{L}_2 \psi$$

Applying to equation (4.27) the same procedures which were applied to (4.15), we obtain after considerable manipulation:

$$\mathcal{L}_{13} T(r, \theta, t) + \mathcal{L}_{14} U(r, \theta, t) - (1/r) a_1 \frac{\partial}{\partial \theta} R + [(\sigma_{\theta z}^{(2p)}/n_2) - (\sigma_{\theta z}^{(1p)}/n_1)]/h^2 = 0 \quad (4.29)$$

with \mathcal{L}_{13} and \mathcal{L}_{14} being differential operators such that

$$\mathcal{L}_{13} \psi = [(n_1/3) \mathcal{L}_{11}^{(1)} \psi + (n_2/3) \mathcal{L}_{11}^{(2)} \psi] \quad (4.30)$$

$$\mathcal{L}_{14} \psi = [(n_1/3) \mathcal{L}_{12}^{(1)} \psi + (n_2/3) \mathcal{L}_{12}^{(2)} \psi] \quad (4.31)$$

and

$$\mathcal{L}_{11}^{(\alpha)} \psi = [E_\alpha - (\lambda^2/E_\alpha)](1/r^2) \frac{\partial^2}{\partial \theta^2} \psi + \mu_\alpha \mathcal{L}_1 \psi - \rho_\alpha \frac{\partial^2}{\partial t^2} \psi \quad (4.32)$$

$$\begin{aligned} \mathcal{L}_{12}^{(\alpha)} \psi &= [(\lambda_\alpha + \mu_\alpha) - (\lambda_\alpha^2/E_\alpha)](1/r) \frac{\partial^2}{\partial r \partial \theta} \psi + \\ &+ [(\lambda_\alpha + 3\mu_\alpha) - (\lambda_\alpha^2/E_\alpha)](1/r^2) \frac{\partial}{\partial \theta} \psi \end{aligned} \quad (4.33)$$

Equations (4.2), (4.4), (4.5) together with (4.12), (4.24) and (4.29) define the quasi-anti-plane motion of the laminated medium as modeled by the present continuum mixture theory. They constitute nine coupled linear partial differential equations for the nine functions $\bar{u}_z^{(\alpha)}$, $\sigma_{\theta z}^{(\alpha p)}$, $\sigma_{rz}^{(\alpha p)}$, U, T and R. Since they are a system of linear equations, they can be manipulated so that they provide two coupled partial differential equations for $\bar{u}_z^{(1)}$ and $\bar{u}_z^{(2)}$; when these displacements are prescribed at the cavity wall together with initial conditions, they can be determined throughout the laminated medium.

For the general case of a θ -dependent loading at the cavity wall, the mixture variables $\bar{u}_z^{(\alpha)}$, $\sigma_{rz}^{(\alpha p)}$ and $\sigma_{\theta z}^{(\alpha p)}$ are functions of the space variables r and θ , as well as time. For the special case of axisymmetric loading, we expect that the partial stresses $\sigma_{\theta z}^{(\alpha p)}$ should vanish. In fact, this can easily be seen first by observing that with $\frac{\partial}{\partial \theta} = 0$ we have:

$$\mathcal{L}_2 = \mathcal{L}_6 = \mathcal{L}_8 = \mathcal{L}_{12} = \mathcal{L}_{14} = 0 \quad (4.34)$$

and the terms containing T in (4.12) and (4.24) vanish. Again with $\frac{\partial}{\partial \theta} = 0$, equation (4.5) gives

$$\sigma_{\theta z}^{(\alpha)} = q_\alpha \mu_\alpha T(r, \theta, t), \quad (4.35)$$

which, when substituted in equation (4.29) yields a differential equation for T which is decoupled from all other variables. Thus, with an axisymmetric tangential loading in the z-direction, clearly we have $T \equiv 0$, which through (4.36) yields

$\sigma_{\theta z}^{(\alpha p)} \equiv 0$. Equation (4.2), (4.4), (4.12) and (4.24) with $\frac{\partial}{\partial \theta} = 0$ define now the axi-symmetric quasi-anti-plane motion of the composite.

5. Conclusion

We have developed an interacting continuum theory for cylindrical wave propagation in a laminated composite. The case of a θ -dependent loading at the cavity wall is treated and the theory is two-dimensional in the sense that the averaged motion of each constituent is dependent on the space coordinates r and θ , as well as time. Note that the construction of the theory is strongly dependent on the specific symmetry conditions which arise due to a uniform loading in the direction of the axis of the cavity. It can be seen that similar symmetry conditions will be present when a laminated half-space, with the surface being perpendicular to the layering, is impacted by a tangential or normal infinite line load perpendicular to the interfaces of the layers. Thus, it is expected that continuum mixture theories of the same type can again be developed for these problems, these in fact being the two-dimensional generalizations of the theories developed in [4] and [7].

References

1. J.D. Achenbach, Waves and vibrations in directionally reinforced composites. Composite Materials (edited by L.J. Broutman and R.H. Krock) Vol. 2, Mechanics of Composite Materials (edited by G.P. Sendeckyj), 309 (1974).
2. F.C. Moon, Wave propagation and impact in composite materials. Composite Materials (edited by L.J. Broutman and R. H. Krock), Vol. 7, Structural Design and Analysis, Part i (edited by C.C. Chamis), 259 (1975).
3. B. Lempriere, On the practicability of analyzing waves in composites by the theory of mixtures. Lockheed Missiles and Space Company Report LMSC-6-78-69-21, April 1969.
4. G.A. Hegemier, G.A. Gurtman and A.H. Nayfeh. A continuum mixture theory of wave propagation in laminated and fiber reinforced composites. International Journal of Solids and Structures 9, 395 (1973).
5. J. Aboudi, A mixture theory of the response of a laminated plate to impulsive loads. Journal of Sound and Vibration 29, 355 (1973).
6. J. Aboudi, Stress wave propagation in a laminated plate under impulsive loads. International Journal of Solids and Structures 9, 217 (1973).
7. A.H. Nayfeh and G. A. Gurtman, A continuum approach to the propagation of shear waves in laminated wave guides. Journal of Applied Mechanics 41, 106-110 (1974).

Figure Captions

1. A circular cylindrical infinite cavity in a bi-laminated composite medium.

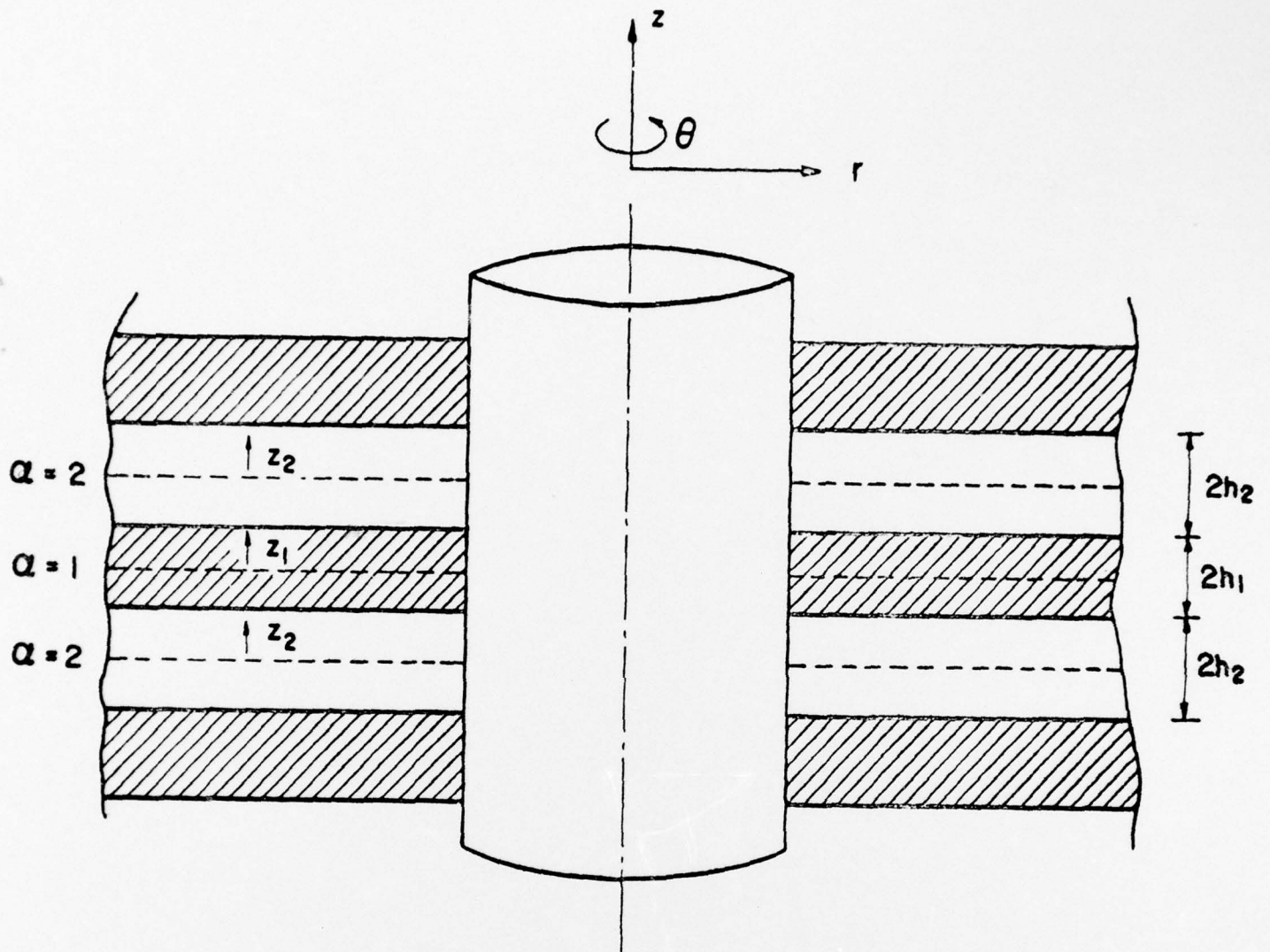

Fig. 1