

AD-A033 899

AIR FORCE GEOPHYSICS LAB HANSCOM AFB MASS  
SATELLITE SENSING OF LOW ENERGY PLASMA BULK MOTION.(U)  
DEC 76 S T LAI, M SMIDDY, P J WILDMAN  
AFGL-TR-76-0281

F/G 22/3

UNCLASSIFIED

NI

1 of 1  
ADA033899



END

DATE  
FILMED  
2 -77

SATELLITE SENSING OF LOW ENERGY PLASMA BULK MOTION

ADA 033899

**COPY AVAILABLE TO DDC DOES NOT PERMIT FULLY LEGIBLE PRODUCTION**

S.T. Lai

Logicon Inc.  
Bedford, Massachusetts 01730

M. Smiddy and P.J.L. Wildman

Air Force Geophysics Laboratory  
Bedford, Massachusetts 01731

12  
NW

Dec 14 73

1. INTRODUCTION

The relative motion between a spacecraft and the plasma surrounding it in the ionosphere and magnetosphere may be investigated directly using planar ion sensors to examine the flow of plasma past the spacecraft. If the plasma is taken to be corotating with the earth, as in the case below about 400 km at middle and low latitudes then all relative motion is due to the spacecraft velocity. This is usually known independently and the planar ion sensors may then be used to determine spacecraft attitude. (Sagalyn and Smiddy, 1969a)

If the ambient plasma has a bulk, drift motion in a frame of reference that rotates with the earth then the situation is more complex. In this case if spacecraft attitude, velocity, and plasma density are known in the corotating frame of reference then the ion sensor data may be used to determine the magnitude and direction of the plasma flow in this frame of reference. These conditions hold generally above about 60° latitude and in these regions increase with height from about 1000 km up.

In this paper we outline the steps required for processing data from an array of planar ion sensors mounted on a spin stabilized satellite. We shall assume that ambient plasma density, spacecraft velocity and attitude in an external frame of reference are all known independently, and proceed to derive the bulk motion of the ambient plasma in this same frame of reference. The determination of spacecraft attitude in the zero plasma motion regime is a simplified form of these results.

2. DETERMINATION OF THE PLASMA FLOW DIRECTION

In this section we derive expressions for the Pitch and Yaw of the plasma flow relative to the spacecraft coordinate system, using the currents flowing to an array of the positive ion sensors. The spacecraft velocity relative to the plasma contains components due to the spacecraft velocity and to any drift or 'bulk' motion of the plasma. To evaluate the component due to plasma motion it is necessary to know

the spacecraft attitude and velocity in an external coordinate system, and this is dealt with in Section 3. First, however, we must derive the Pitch and Yaw angles of the plasma flow in the spacecraft geometric coordinates.

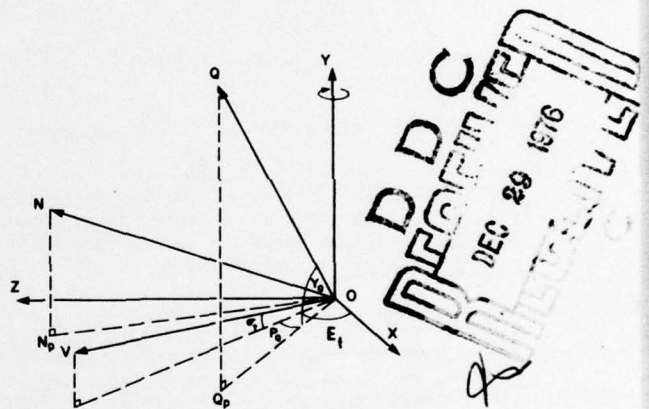

Figure 1. Geometry of Sensor in Ion Flow

In Figure 1 we show x y z, the spacecraft coordinates; ON is the normal to the planar sensor aperture, and OQ (q) is the relative plasma flow vector with Pitch ( $E_t + P_q$ ) and Yaw  $Y_q$ . Angle  $E_t$  is a time dependent measure of the rotational position of the spacecraft as it spins about the y axis. OV (v) is the satellite velocity vector, which at time t is inclined to the x z plane at angle  $\sigma_t$ . This angle varies with time only when the true spin axis of the vehicle does not coincide with a spacecraft geometric axis, and this situation is dealt with in Section 4.

The direction Cosines of OQ are:

$$\begin{aligned} & \cos Y_q \cos (E_t + P_q) \\ & \sin Y_q \\ & \cos Y_q \sin (E_t + P_q) \end{aligned} \quad (1)$$

Similarly, for ON

$$\begin{aligned} & \cos Y_s \cos P_s \\ & \sin Y_s \\ & \cos Y_s \sin P_s \end{aligned} \quad (2)$$

where  $P_s$  and  $Y_s$  are the Pitch and Yaw of the sensor normal.

For unambiguous measurement of  $P_Q$  and  $Y_Q$ , two orthogonal pairs of such sensors are required and the actual configuration used is shown in Fig. 2.

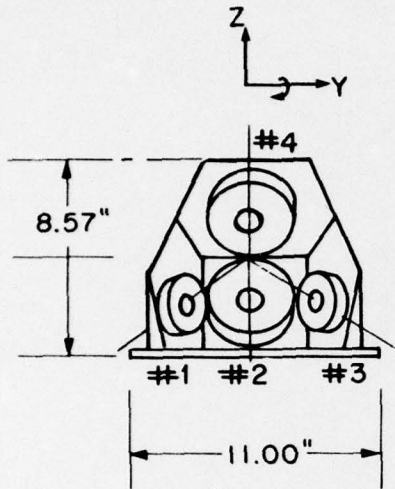

Figure 2. Front View of Ion Sensor Array.

The lower three sensors, #1, #2, and #3 measure Yaw, and the vertical pair, #2 and #4 measure Pitch as the array faces the plasma flow vector once during each spacecraft spin.

Realistically we must take account of any minor offsets in the mounting of such a sensor array relative to the spacecraft geometric axis  $x y z$ . If the centerline of the array (line bisecting normals of sensors #2 and #4), nominally on the  $x$  axis, is rotated  $\gamma$  degrees about the  $y$  axis and  $\epsilon$  degrees about the  $z$  axis, then we have fully described the alignment of the sensor array relative to the spacecraft axes. The angle between the normals of any two adjacent sensors is  $2\alpha$  so that the values of  $P_s$  and  $Y_s$  for the four sensors are as follows:

TABLE I

Sensor No.	1	2	3	4
$P_s$	$-(\alpha-\gamma)$	$-(\alpha-\gamma)$	$-(\alpha-\gamma)$	$(\alpha+\gamma)$
$Y_s$	$-(2\alpha+\epsilon)$	$-\epsilon$	$-(2\alpha-\epsilon)$	$-\epsilon$

Considering again the ion flow to a single sensor, we assume that the mean thermal (isotropic) velocity of the ions is much less than the spacecraft velocity (Sagalyn and Smiddy, 1969b) so that  $I$ , the sensor current is given by:

$$I = \xi N e A q \cos \phi \quad (3)$$

where:

$\xi$  = transmission of the aperture

$N$  = ambient ion density

$e$  = electron charge

$q$  = relative velocity between plasma and spacecraft

$A$  = aperture area

$\phi$  = angle between  $q$  and aperture normal (NOQ in Fig. 1)

Note that  $q$  may or may not contain component due to plasma flow.

Using the direction Cosines of OQ and ON from (1) and (2) to derive  $\cos \phi$ , we obtain:

$$I = \xi N e A q [\cos Y_Q \cos Y_{S_A} \cos (P_Q - P_S + E_t) + \sin Y_Q \sin Y_S] \quad (4)$$

$$\text{Let } \eta = \xi N e A q \quad (5)$$

$$Y = Y_Q \quad (6)$$

$$X = P_Q + \alpha - \gamma + E_t \quad (7)$$

From Equation 4 and the angles given in Table I we obtain the following relations where;

$$R_{ij} = (I_i - I_j) / (I_i + I_j) \quad (8)$$

$$R_{21} = \tan \alpha \frac{\cos X (\tan \alpha + \epsilon) + \tan Y}{\cos X - \tan Y \tan (\alpha + \epsilon)} \quad (9)$$

$$R_{13} = -\tan 2\alpha \frac{\cos X \tan \epsilon + \tan Y}{\cos X - \tan Y \tan \epsilon} \quad (10)$$

$$R_{23} = \tan \alpha \frac{\cos X \tan (\alpha - \epsilon) - \tan Y}{\cos X + \tan Y \tan (\alpha - \epsilon)} \quad (11)$$

$$I_1 + I_3 = 2 I_2 \cos 2\alpha \quad (12)$$

$$\text{Now let } \tan \phi = \tan Y / \cos X \quad (13)$$

then:

$$R_{21} = \tan \alpha \tan (\alpha + \epsilon + \phi) \quad (14)$$

$$R_{23} = \tan \alpha \tan (\alpha - \epsilon - \phi) \quad (15)$$

$$R_{13} = -\tan 2\alpha \tan (\epsilon + \phi) \quad (16)$$

$$\text{and } R_{24} = \frac{\sin \alpha \sin (\alpha - X)}{\cos \alpha \cos (\alpha - X) - \tan Y \tan \epsilon} \quad (17)$$

Define X such that:

$$X = \frac{R_{13} + \tan 2 \alpha \tan \epsilon}{R_{13} - \tan 2 \alpha \frac{\cos \epsilon}{\cot \epsilon}} \quad (18)$$

$$R_{24} \frac{1 - X}{1 + X R_{24}} = \tan \alpha \tan (\alpha - X) \quad (19)$$

In equation 19, X is the only unknown,

$$\tan (P_Q + E_t - \gamma) = \frac{-R_{24}}{\tan \alpha} \frac{1 - X}{1 + X R_{24}} \quad (20)$$

We can now insert value of X just evaluated, into equations 14 or 15, and 16 to determine  $Y_Q$ . The choice between  $R_{21}$  and  $R_{23}$  depending on which side of the centerline the plasma flow is located.

### 3. DERIVATION OF PLASMA VELOCITY VECTOR

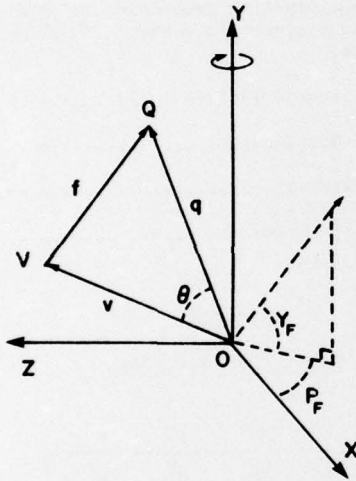

Figure 3. Definition of Ion Flow Vector.

In Figure 3 we show the vector triangle containing the true plasma flow vector f together with v and q from Section 2. The angle  $\theta$ , between v and q is determined knowing  $P_Q$  and  $Y_Q$  from Section 2. The value of v, the spacecraft velocity vector is supplied independently, and q, the relative velocity between the plasma and the spacecraft is derived from Equation 1 where q is now the only unknown.

In Figure 3 we now have:

$$f^2 = q^2 + v^2 - 2q v \cos \theta \quad (21)$$

Explicitly:

$$f^2 = q^2 + v^2 - 2q v (\cos \sigma_t \cos Y_Q \cos P_Q + \sin \sigma_t \sin Y_Q) \quad (22)$$

The direction cosines of the true plasma flow are given by:

$$\cos \alpha = [V \cos \sigma_t \cos E_t - q \cos Y_Q \cos (E_t + P_Q)] / f \quad (23)$$

$$\cos \beta = [V \sin \sigma_t - q \sin Y_Q] / f \quad (24)$$

$$\cos \mu = [V \cos \sigma_t \sin E_t - q \cos Y_Q \sin (E_t + P_Q)] / f \quad (25)$$

The pitch  $P_F$  and Yaw  $Y_F$  angles of the true plasma flow are related to these direction cosines by:

$$\cos Y_F \cos (E_t + P_F) = \cos \alpha \quad (26)$$

$$\sin P_F = \cos \beta \quad (27)$$

$$\cos Y_F \sin (E_t + P_F) = \cos \mu \quad (28)$$

Thus, the pitch and yaw angles can be determined in terms of the magnitudes and directions of relative plasma flow and vehicle velocity;

$$\tan (E_t + P_F) = \frac{V \cos \sigma_t \sin E_t - q \cos Y_Q \sin (E_t + P_Q)}{V \cos \sigma_t \cos E_t - q \cos Y_Q \cos (E_t + P_Q)} \quad (29)$$

$$\tan Y_F = \frac{V \sin \sigma_t - q \sin Y_Q}{[V^2 \cos^2 \sigma_t + q^2 \cos^2 Y_Q - 2Vq \cos \sigma_t \cos P_Q \cos Y_Q]^{1/2}} \quad (30)$$

### 4. THE EFFECT OF SPIN AXIS OFFSET

The previous results have been derived in terms of instantaneous values of all variables. In this section we consider the effect of a spacecraft spin axis displaced from the geometric x y z axes in Fig. 1. This is a realistic condition since in flight the exact location of the spin axis will be set by the deployment of antennas and other items. This introduces a precession of the spacecraft coordinate system x y z about the true spin axis, and the true spin axis sweeps out a circular precession conic about the spacecraft y axis, with half angle A at the spin frequency  $\omega$ .

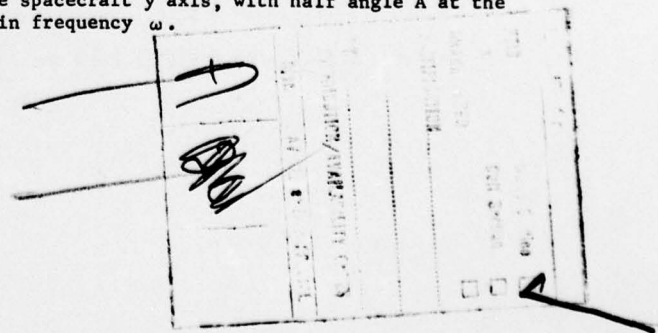

Let us now define a new spacecraft coordinate system  $x'y'z'$  in which  $y'$  is at angle  $A$  to the  $y$  axis and for simplicity of illustration  $x'$  is taken to coincide with the  $x$  axis. If  $x'$  and  $x$  do not coincide then a rotation about the  $y$  axis is required, affecting transformation 31. If all spacecraft attitude data is supplied in the 'prime' system in order to remove the modulation caused by spin axis offset then we must establish a means of using these data with the instrument outputs in section 3 in order to derive the plasma magnitude and velocity in any coordinate system external to the spacecraft. The two spacecraft coordinate systems at time to when the spin axis lies in the  $yz$  plane, are related by:

$$\begin{bmatrix} x' \\ y' \\ z' \end{bmatrix} = \begin{bmatrix} 1 & 0 & 0 \\ 0 & \cos A & -\sin A \\ 0 & \sin A & \cos A \end{bmatrix} \begin{bmatrix} x \\ y \\ z \end{bmatrix} \quad (31)$$

where the transformation matrix is orthogonal.

To transform velocity  $v'$  as supplied by the attitude system under these operating conditions, to  $v$  in the  $x y z$  system:

$$\begin{bmatrix} v_{xt} \\ v_{yt} \\ v_{zt} \end{bmatrix} = \begin{bmatrix} 1 & 0 & 0 \\ 0 & \cos A & \sin A \\ 0 & -\sin A & \cos A \end{bmatrix} \begin{bmatrix} \cos \omega t & 0 & -\sin \omega t \\ 0 & 1 & 0 \\ \sin \omega t & 0 & \cos \omega t \end{bmatrix} \begin{bmatrix} v'_{xt_0} \\ v'_{yt_0} \\ v'_{zt_0} \end{bmatrix} \quad (32)$$

Explicitly the velocity vector  $V(t)$  at time  $t$  in spacecraft  $x y z$  coordinates can be obtained from  $V'_{t_0}$  by:

$$\begin{bmatrix} v_x(t) \\ v_y(t) \\ v_z(t) \end{bmatrix} = \begin{bmatrix} v'_x(t_0) \cos \omega t - v'_z(t_0) \sin \omega t \\ v'_x(t_0) \sin \theta \sin \omega t + v'_y(t_0) \cos \theta + v'_z(t_0) \sin \theta \cos t \\ v'_x(t_0) \cos \theta \sin \omega t - v'_y(t_0) \sin \theta + v'_z(t_0) \cos \theta \cos t \end{bmatrix} \quad (33)$$

Referring to Fig. 1, the pitch  $E_t$  and yaw  $\sigma_t$  angles of the velocity  $v$  are obtained in terms of  $E'(t_0)$ ,  $\sigma'(t_0)$ ,  $\theta$ , and  $\omega$  as:

$$E_t = \tan^{-1} \left\{ \frac{1}{\cos E'(t_0) + \omega t} \times \left[ \cos E'(t_0) \cos \theta \sin \omega t + \sin \theta (\sin E'(t_0) \cos \omega t - \tan \sigma'(t_0)) \right] \right\} \quad (34)$$

$$\sigma_t = \tan^{-1} \left\{ \left[ \sin^2 (E'(t_0) + \omega t) + \tan^2 \sigma'(t_0) \right]^{-\frac{1}{2}} \left[ \cos E'(t_0) \sin \theta \sin \omega t + \tan \sigma'(t_0) \cos \theta + \sin E'(t_0) \sin \theta \cos \omega t \right] \right\} \quad (35)$$

## 5. APPENDIX

The transformation properties of four useful coordinate systems are listed in Table II. The systems are:

- Earth Centered Inertial.....e
- Orbital Coordinates.....o
- Local Vertical.....l
- Spacecraft Coordinates.....s

TABLE II  
COORDINATE TRANSFORMS

	e	o	l	s
e	-	$D^T$	$C^T$	$E^T$
o	$D$	-	$B^T$	$A_0^T$
l	$C$	$B$	-	$A_1^T$
s	$E$	$A_0$	$A_1$	-

For example:

$$e = E^T S, o = De$$

where lower case indicates 3 x 1 column matrices, and capital denotes 3 x 3 square matrices.

The transforms are as follow:

$$A_o = \begin{bmatrix} \cos \nu_o \cos \psi_o & \cos \nu_o \sin \psi_o \cos \varphi_o - \sin \nu_o \sin \varphi_o & \cos \nu_o \sin \psi_o \sin \varphi_o + \sin \nu_o \cos \varphi_o \\ -\sin \psi_o & \cos \psi_o \cos \varphi_o & \cos \psi_o \sin \varphi_o \\ -\sin \nu_o \cos \psi_o & -\sin \nu_o \sin \psi_o \cos \varphi_o - \cos \nu_o \sin \varphi_o & -\sin \nu_o \sin \psi_o \sin \varphi_o + \cos \nu_o \cos \varphi_o \end{bmatrix}$$

$A_1 = A_o$  with subscripts o replaced by 1.

$$B = \begin{bmatrix} \cos \theta & 0 & \sin \theta \\ 0 & 1 & 0 \\ -\sin \theta & 0 & \cos \theta \end{bmatrix}$$

$$C = \begin{bmatrix} -\cos \theta \cos i \sin \Omega - \sin \theta \cos \Omega & \cos \theta \cos i \cos \Omega - \sin \theta \sin \Omega & \cos \theta \sin i \\ -\sin i \sin \Omega & \sin i \cos \Omega & \cos i \\ \sin \theta \cos i \sin \Omega - \cos \theta \cos \Omega & -\sin \theta \cos i \cos \Omega - \cos \theta \sin \Omega & -\sin \theta \sin i \end{bmatrix}$$

$$D = \begin{bmatrix} -\cos i \sin \Omega & \cos i \cos \Omega & \sin i \\ -\sin i \sin \Omega & \sin i \cos \Omega & \cos i \\ -\cos \Omega & -\sin \Omega & 0 \end{bmatrix}$$

$$E = A_o D = A_1 C$$

where superscript T denotes transpose matrix,

$\theta$  = latitude

$\Omega$  = right ascension

$\varphi$  = roll

$\psi$  = yaw

$\nu$  = pitch

#### REFERENCES

Donahue, T.M., 1971, Rev. of Geophysics and Space Physics, 9, No. 1, p. 1. "Polar Ion Flow: Wind or Breeze?"

Sagalyn, R.C. and M. Smiddy, 1969a, J. Spacecraft and Rockets, 6, No. 9, p. 985. "Positive Ion Measurement of Spacecraft Attitude: Gemini X and XII".

Sagalyn, R.C. and M. Smiddy, 1969b, AFCRL-69-0426, Instrumentation Paper No. 160; "Charged Particle Measurement by Means of Electrostatic Probes".

## DOCUMENT CONTROL DATA - R&amp;D

(Security classification of title, body of abstract and indexing annotation must be entered when the overall report is classified)

## 1. ORIGINATING ACTIVITY (Corporate author)

Air Force Geophysics Laboratory (PHR) ✓  
Hanscom AFB  
Massachusetts 01731

## 2a. REPORT SECURITY CLASSIFICATION

## 2b. GROUP

## 3. REPORT TITLE

SATELLITE SENSING OF LOW ENERGY PLASMA BULK MOTION

## 4. DESCRIPTIVE NOTES (Type of report and inclusive dates)

Scientific. (9) Interim Rept.

## 5. AUTHOR(S) (First name, middle initial, last name)

S. T. Lal  
M. Smiddy  
P. J. L. Wildman

(11) 7 Dec 76

(12) 6p.

## 6. REPORT DATE

7 December 1976

## 7a. TOTAL NO. OF PAGES

5

## 7b. NO. OF REFS

3

## 8a. CONTRACT OR GRANT NO.

(16)

b. PROJECT, TASK, WORK UNIT NOS. 2311G203

## 8b. ORIGINATOR'S REPORT NUMBER(S)

(14) AFGL-TR-76-0281 ✓

## c. DOD ELEMENT

(17)  
G2

61102F

## d. DOD SUBELEMENT

## 9b. OTHER REPORT NO(S) (Any other numbers that may be assigned this report)

## 10. DISTRIBUTION STATEMENT

Approved for public release; distribution unlimited.

11. SUPPLEMENTARY NOTES Reprinted from Pre-print Vol, 7th Conf on Aerospace &amp; Aeronautical Meteorology &amp; Symposium on Remote Sensing from Satellite, Nov 16-19, 1976, Melbourne, Florida

## 12. SPONSORING MILITARY ACTIVITY

Air Force Geophysics Laboratory (PHR)  
Hanscom AFB  
Massachusetts 01731

## 13. ABSTRACT

→ Low-energy plasma motion in the ionospheric-magnetospheric region may be measured directly using an array of planar ion sensors on a spin-stabilized satellite. In the equatorial, low-altitude (below 400 km), zero plasma motion<sup>a</sup> region, the relative plasma flow is due to spacecraft velocity only; the sensors give information concerning the attitude of the spacecraft in the plasma. In the polar regions or at higher altitudes, plasma flow is important, and the attitude and ephemeris data of the spacecraft in an external system are necessary for the determination of plasma flow in this system. We outline a sensor system that measures the flow of low-energy plasma and proceed to define all the additional information required to operate in the moving plasma region, together with the coordinate transforms this involves. Corrections are derived for three factors that arise in the practical application of such an instrument: 1) the offset between spacecraft geometric axes and the actual alignment of the sensors as mounted; 2) the offset between spacecraft geometric axes and the spin-axis location achieved in flight; and 3) the separation of the spacecraft velocity vector from the spacecraft spin plane. ←

KEYWORDS: Plasma bulk motion, Ion drift, Polar wind, Ion sensors, Spacecraft altitude, Spacecraft coordinate transforms