

AD-A033 921

BIOTECHNOLOGY INC FALLS CHURCH VA  
A GUIDE FOR SELECTING FORMATS AND MEDIA FOR PRESENTING MAINTENANCE--ETC(U)  
NOV 76 T POST, H PRICE, G DIFFLEY

F/G 5/2

N00600-76-C-1373

NL

UNCLASSIFIED

1 of 1  
ADA033921



ADA 033921

12

**A GUIDE FOR SELECTING FORMATS AND MEDIA  
FOR PRESENTING MAINTENANCE INFORMATION**

*By*  
T. Post  
H. Price  
G. Diffley

*Prepared for*  
David W. Taylor  
Naval Ship Research and Development Center  
Bethesda, Maryland 20084

November 1976

DDC  
RECEIVED  
JAN 4 1977  
C

Contract No. N00600-76-C-1373

**DISTRIBUTION STATEMENT A**  
Approved for public release  
Distribution Unlimited

BioTechnology, Inc. ✓  
3027 ROSEMARY LANE • FALLS CHURCH, VIRGINIA

UNCLASSIFIED

SECURITY CLASSIFICATION OF THIS PAGE (When Data Entered)

REPORT DOCUMENTATION PAGE		READ INSTRUCTIONS BEFORE COMPLETING FORM
1. REPORT NUMBER	2. GOVT ACCESSION NO.	3. RECIPIENT'S CATALOG NUMBER
4. TITLE (and Subtitle) <b>6</b> A Guide for Selecting Formats and Media for Presenting Maintenance Information		5. TYPE OF REPORT & PERIOD COVERED <b>9</b> Interim <i>rept.</i>
7. AUTHOR(s) <i>Harold Gary</i> T. Post, H. Price, G. Diffley		6. PERFORMING ORG. REPORT NUMBER
9. PERFORMING ORGANIZATION NAME AND ADDRESS D. W. Taylor Naval Ship Research and Development Center Bethesda, Maryland 20084		8. CONTRACT OR GRANT NUMBER(s) <b>15</b> <del>N00600</del> -76-C-1373 <i>new</i>
11. CONTROLLING OFFICE NAME AND ADDRESS Naval Air Systems Command Equipment & Support Administrator (AIR-340) Washington, D.C. 20360		10. PROGRAM ELEMENT, PROJECT, TASK AREA & WORK UNIT NUMBERS
14. MONITORING AGENCY NAME & ADDRESS (if different from Controlling Office) D.W. Taylor Naval Ship Research and Development Center Bethesda, Maryland 20084		12. REPORT DATE <b>11</b> November 1976
		13. NUMBER OF PAGES 51 <b>12</b> <i>57 p.</i>
		15. SECURITY CLASS. (of this report) Unclassified
		15a. DECLASSIFICATION/DOWNGRADING SCHEDULE
16. DISTRIBUTION STATEMENT (of this Report) Approved for Public Release: Distribution Unlimited		
17. DISTRIBUTION STATEMENT (of the abstract entered in Block 20, if different from Report)		
18. SUPPLEMENTARY NOTES		
19. KEY WORDS (Continue on reverse side if necessary and identify by block number) Technical Manual; Formats; Media; Procurement Decisions; TM-relevant Conditions of Use; Information Technology; Maintenance.		
20. ABSTRACT (Continue on reverse side if necessary and identify by block number) This document describes a method for selecting formats and media to use in presenting maintenance information. The method is intended for use by program management personnel/equipment component engineers at the early stages of system development when TM procurement decisions are made. Its unique features include: o matching TM formats to personnel, equipment, and workplace characteristics; and, o bringing cost considerations into the TM selection process. A five step selection process is proposed, as follows: (1) gather maintenance-action and system-condition data; (2) identify cases where standardized formats are required; (3) select formats for troubleshooting actions; (4) select formats for remove and replace actions; and (5) establish TM support requirements. <b>058 050</b>		



## FOREWORD

The research reported here developed a method for selecting formats and media for presenting maintenance information. The work was sponsored by the Navy Technical Information Presentation Project (NTIPP), an exploratory development program being conducted by the David W. Taylor Naval Ship Research and Development Laboratory, Carderock, Maryland.

The technical monitor of this work effort was Mr. Joseph Fuller of NSRDC. Mr. T. Post of BioTechnology, Inc. was the principal investigator. He was supported by Mr. Gary Diffley. The project was conducted as part of the Personnel Performance Architecture Program at BioTechnology managed by Mr. Harold Price.

The Navy plans to evaluate the product of this research in a shipboard setting. The evaluation will assess the feasibility of applying the method (does the guide provide adequate guidance for selecting formats and media?) and the utility of the selection (what are the benefits of presenting information in the formats and media indicated by the selection method?).

*Robert A Sulit*  
Technical Manager, Navy Technical  
Information Presentation  
Project

A rectangular stamp or form with a grid. The top section contains text: "RECEIVED BY", "DATE", "TIME", "BY", "TITLE", "OFFICE", "PHONE", "FAX", "E-MAIL". There are checkboxes for "RECEIVED" and "FILED". A large handwritten letter "A" is in the bottom left cell of the grid. A checkmark is in the top right corner of the stamp.

## TABLE OF CONTENTS

	<u>Page</u>
1.0 Introduction . . . . .	1
1.1 Scope . . . . .	1
1.2 Background . . . . .	1
1.3 Major Considerations of the Selection Method . . . . .	1
1.4 Summary of the Selection Method . . . . .	2
1.5 Status of Selection Concept . . . . .	4
2.0 Gather Maintenance Action and System Condition Data . . . . .	5
2.1 Introduction . . . . .	5
2.2 Review Task Identification Matrix (TIM) . . . . .	5
2.3 Establish System Conditions . . . . .	6
3.0 Identify Special Case Maintenance Actions (MAs) . . . . .	8
3.1 Introduction . . . . .	8
3.2 Standard Operating Procedures (SOPs) . . . . .	8
3.3 One Trial Learning MAs . . . . .	10
3.4 High Complexity MAs . . . . .	11
3.5 Time Critical, Performances . . . . .	12
3.6 Periodic Maintenance . . . . .	13
4.0 Select Formats for Presenting Troubleshooting Information . . . . .	14
4.1 Available Formats . . . . .	14
4.2 Selection Process . . . . .	14
4.3 Identify Format Candidates for Homogeneous Sets of Troubleshooting MAs . . . . .	19
4.4 Compare Costs of Deductive and Proceduralized Formats . . . . .	21
4.5 Consider System Condition Indicators . . . . .	21
4.6 Make Final Format Selection . . . . .	26
5.0 Select Formats for Presenting Remove and Replace Actions . . . . .	28
5.1 Available Formats . . . . .	28
5.2 Selection Process . . . . .	28
5.3 Select Homogeneous Set of Remove and Replace Actions . . . . .	32
5.4 Compare Costs of Deductive and Proceduralized Formats . . . . .	32
5.5 Consider System Condition Indicators . . . . .	33
5.6 Make Final Format Selection . . . . .	34
6.0 Establish TM Support Requirements . . . . .	36
6.1 Introduction . . . . .	36
6.2 Determine Access Requirements . . . . .	37
6.3 Determine Recording Medium Requirements . . . . .	46
6.4 Determine Portrayal Mode Requirements . . . . .	46

## LIST OF FIGURES

<u>Figure</u>	<u>Page</u>
1 Overview of the Selection Method . . . . .	3
2 Typical Entries in a Task Identification Matrix (TIM) . . . . .	5
3 Format to Use in Preparing a Fully Proceduralized, Dual-Level Description of an SOP . . . . .	9
4 Location Diagram Suitable for Supporting One-Trial Learning Action . . . . .	.10
5 Proceduralized Format Emphasizing "Training Notes" Intended to Support Unusually Complex MAs . . . . .	.11
6 Pictorial Emphasis in a Format to Support Time-Critical, Hazardous Actions . . . . .	.12
7 Sample Format for Describing Periodic MAs . . . . .	.13
8 Formats Available to Present Information to Support Troubleshooting . . . . .	.14
9 Illustration of a Fully Proceduralized Format for Presenting Troubleshooting Guidance . . . . .	.15
10 Illustration of a Partially Proceduralized Format for Presenting Troubleshooting Guidance . . . . .	.16
11 Sample of a Deductive (Simple Logic) Format for Troubleshooting . . . . .	.17
12 Illustration of a Deductive (System Description) Format for Troubleshooting . . . . .	.18
13 Topdown Breakdown and System Conditions to Illustrate Homogeneous Sets of MAs . . . . .	.10
14 Topdown Breakdown (Partial) to Illustrate Cost Estimations . . . . .	.22
15 Part Breakdown from Current TM . . . . .	.24
16 Coordinated Proceduralized-and-Deductive Formats . . . . .	.25
17 Formats Available for Presenting Remove and Replace Information . . . . .	.28
18 Sample of Fully Proceduralized Format for Supporting Remove and Replace Actions . . . . .	.29
19 Sample of Partially Proceduralized Format for Supporting Remove and Replace Actions . . . . .	.30
20 Sample of Component Description Format for Supporting Remove and Replace Actions . . . . .	.31
21 Indexing Sample for Accessing Work Packages . . . . .	.38
22 Local Table of Contents for a Work Package . . . . .	.39
23 Sample of a Periodicity Index for Scheduled Inspections . . . . .	.40
24 Sample Format for Indexing for Mechanical Equipment . . . . .	.41
25 Sample of Overview Format for Follow-on Maintenance . . . . .	.42
26 Sample of "Refer to" Format for Follow-on Maintenance . . . . .	.42
27 Access to Troubleshooting Aids Via Status Indicators . . . . .	.43
28 Sample of a Decision Logic Table Format for Using Status Displays to Index Aids . . . . .	.44
29 Access to Troubleshooting Aids Via Built-in Tests, Sample Format . . . . .	.45
30 Sample Microform Recording Medium . . . . .	.47
31 Example of Microform Recording Medium with Printout Capability . . . . .	.47
32 Hooded Viewer . . . . .	.49
33 Representative Portable Booklet Aid . . . . .	.50
34 Self Illuminated Viewer . . . . .	.50

## LIST OF TABLES

<u>Table</u>		<u>Page</u>
1	System Conditions Affecting Formats and Media . . . . .	6
2	Summary of Conditions Affecting Troubleshooting Format . . . . .	.19
3	Example of Applying System Condition Indicators to the Problem of Selecting a Format for Presenting Troubleshooting Information . . . . .	.27
4	Summary of System Conditions Affecting Format for Presenting Remove and Replace Actions . . . . .	.34
5	Example of Applying System Condition Indicators to the Problem of Selecting Format for Presenting Remove and Replace Information . . . . .	.35
6	System Conditions Affecting Support Requirements . . . . .	.36
7	Workspace Conditions and Matching Media . . . . .	.48

## 1.0 INTRODUCTION

### 1.1 Scope

**What.** This guide sets forth a new concept for selecting formats and media to be used in presenting maintenance information. Format refers to the arrangement of information within a presentation. Medium refers to the means used to record, store, and display the information.

**By Whom.** Format and medium selection will be accomplished by Navy officials at the program management level. Equipment component engineers representing government or contractor organizations are alternate users.

**When.** Formats and media are to be selected during each system acquisition. The selection should occur before Detailed Design, and ideally during development of the Operational Requirement or during preparation of the contractor's proposal. Therefore, the selection method excludes consideration of information which is not available at this stage, i.e., conventional task analysis.

### 1.2 Background

#### Usability Problems of Standardized TMs.

Historically, standard technical manuals (TMs) have been procured for all Navy systems, even though conditions of TM use and technician's information needs have not been the same in all systems.

The standard TM approach is popular because of the efficiencies it allows in the production portion of the TM life cycle, viz., minimum design costs and consistent TM products from a large number of vendors. This guide's concept for selecting formats and media questions the standard TM approach claiming that production benefits may be negated by usability problems which that approach produces.

TM usability problems are defined as conflicts between conditions of use in a system and the formats-media of the system's TM. Such conflicts may cause technicians to underuse the TM because the effort required to overcome the conflict is more than the

perceived benefit of using the TM. These conflicts may explain claims that technicians spend very little of their time referring to TMs.

#### Maintenance Impact of Usability Problems

When TM formats and media do not match conditions of use within the system, technicians have two options. They may reject TMs as a source of guidance in favor of more convenient but more fallible sources (e.g., memory, peers, ingenuity, or supervisors with limited time) or they may try to use the TM in spite of its usability problems. Both alternatives contribute to ineffective maintenance, e.g., false removals frequently exceed 20 percent, and performance capability of new technicians is poor even on the simpler maintenance activities.

### 1.3 Major Considerations of the Selection Method

This guide considers the use of both conventional and innovative formats and media. The guide is intended to help Navy officials select formats and media which will match conditions of use expected in the system to be supported.

Use of the guide's selection procedures involves five considerations which are listed below and discussed in the following text.

- Maintenance Actions (MAs)
- System Conditions
- Homogeneous Sets of MAs
- Innovative Formats and Media
- TM Preparation Cost.

#### Maintenance Actions

The format chosen to support an MA depends on the type of MA being supported, the conditions under which the technician must perform it, and the number of MAs involved. Knowing that ten troubleshooting actions are required is a necessary but not sufficient basis for selecting a format. The reason for including conditions is that they may vary and that different conditions suggest different formats.

In order to include cost as a selection consideration it is necessary to know the number of MAs being supported. Some formats are such that a single presentation supports a group of MAs (of the same type) while competing formats require separate presentations for each MA being supported. Considerable cost differences can emerge depending on the number of MAs involved. Thus, to make final format selections it is necessary to know the type and number of MAs being supported and the format-relevant conditions of their performance.

#### System Conditions

"...too bulky; too complex; too hard to find information" are typical complaints heard about conventional TMs. Such complaints are more meaningful when they relate to specific formats/media and system conditions. For example, paper medium books for large systems are too bulky when workstations are remote from the TM library; or conventional system descriptions are too complex for *poor readers*. When used in this sense, conditions tend to highlight deficiencies in conventional TMs, establishing requirements for innovative formats-media (e.g., for pocket size booklets and for readable system descriptions).

The guide uses 23 maintenance-relevant conditions to help select formats and media. These conditions are truly system-oriented in that they cover the tasks to be performed (4 conditions), the characteristics of the performer (6 conditions), the hardware being maintained (9 conditions), and the workspace of the performance (4 conditions). Maximizing the match between these conditions and the formats and media used to present a system's maintenance information is essential to the success of a Technical Manual (TM).

#### Homogeneous Sets of Maintenance Actions

Some systems require hundreds of MAs. The expense and time of selecting a format and medium for each would be prohibitive. A substantial reduction of time and effort is possible by combining MAs into homogeneous sets. MAs are homogeneous when they are of the same type (all troubleshooting) and are performed under the same system conditions. In this manner the hundreds of selections can be telescoped down to a more reasonable number.

#### Innovative Formats and Media

The format and medium of conventional TMs are satisfactory for a limited set of system conditions, but as these conditions change (e.g., as systems grow bigger or as personnel turnover increases) the conventional TM begins to lose its effectiveness. Innovative formats and media have been designed to cope with these harsher conditions but they are not necessarily cost-effective for universal application. This guide uses system conditions as a means of "limiting" a format or medium to the circumstances it is designed to handle.

The inset below uses one system condition (personnel turnover) to illustrate how it can influence format (and medium) selection. As shown, this condition can occur in either a HIGH or LOW state.

System Condition	Format or Medium Prescription
Personnel Turnover { High	Fully Proceduralized Troubleshooting Format
Low	Conventional Troubleshooting Format

A high turnover: (1) results in a large percentage of inexperienced technicians in the work crew and (2) indicates the need to minimize or delay training of initial entry personnel. Fully proceduralized aids have been shown to be better than conventional TM presentations in coping with these consequences of a high turnover condition. The fully proceduralized aid format enables inexperienced technicians to perform quite effectively with a minimum of "front end" training.

In the low turnover condition more training is economical and a greater number of inexperienced technicians would be expected. For this group, conventional TM coverage would be sufficient to support performance.

Each of the 23 conditions which this guide suggests for helping to select formats and media is by itself inconclusive. However, they are much more convincing when they are considered in combination. When the tendencies of many of the conditions agree, a conclusive case for the format or medium is available; when the tendencies are not all in the same direction a tradeoff situation is established. Both cases represent improvements over earlier selection approaches.

### TM Preparation Cost

Many innovative formats and media relate to their specified system conditions much more effectively than their conventional, usually less expensive, counterparts. A judgment is required to determine whether the usually higher cost of the innovation is worthwhile. Thus, this guide includes a method for estimating the cost of

formats available to support various maintenance actions.

### 1.4 Summary of the Selection Method

The method for selecting formats and media for presenting a system's maintenance information is performed in the five steps shown in Figure 1 and discussed below.

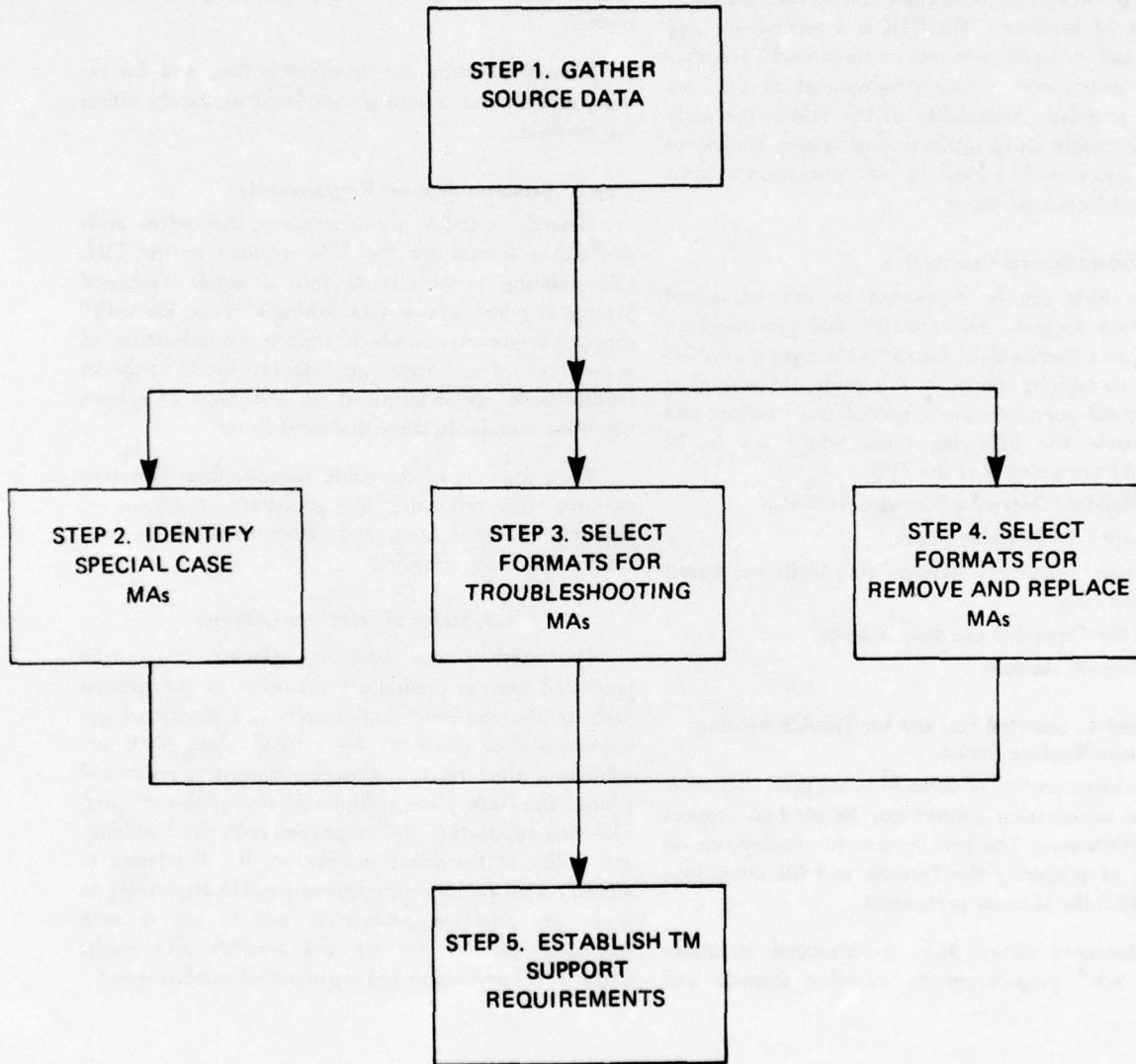

Figure 1. Overview of the Selection Method.

### Step 1. Gather Source Data

The process for selecting formats and media relies on system conditions and cost of available formats, as described above. Both of these inputs are based on the maintenance actions required by a system. A convenient and systematic source for identifying MAs is the Task Identification Matrix (TIM). The TIM is a structure which lists the specific MAs applicable to each maintainable unit of hardware. The TIM is a preliminary step towards task analysis, not task analysis itself, and thus can be created even during development of the contractor's proposal. Availability of the TIM at this early stage will enable an identification of system conditions and will also provide a base for cost estimation to assist in the final format selection.

### Step 2. Select Special Case Actions

Some MAs can be supported by any of several presentation formats, but research and practice have shown that a standardized format is the most cost-effective way to support others. In this guide, the actions of the latter category are called "special case" actions and they include the following types which are to be identified from a review of the TIM.

- Standard Operating Procedures (SOPs)
- One Trial Learning Actions
- High Complexity Actions, viz., Calibrate, Adjust and Align
- Time Critical, Hazardous Actions
- Periodic Actions

### Steps 3 and 4. Selected Formats for Troubleshooting and Remove/Replace Actions

The characteristics of these MAs are such that more than one information format can be used to support their performance. The best format to use depends on the cost of preparing the formats and the conditions under which the MAs are performed.

As discussed above, MAs are arranged in homogeneous sets\* preparatory to selecting formats and

media. For each homogeneous set, cost estimates are made for preparing information in the available formats. Then, system conditions of the set are considered as follows: (1) If there is a significant cost difference between the available formats, system conditions are used to override or reinforce use of the least costly. (2) If costs for preparing format options are comparable, system conditions are used to indicate the most effective format.

Format selection for troubleshooting, and for remove and replace actions is considered separately within this method.

### Step 5. Establish Support Requirements

Steps 2, 3, and 4 above concern themselves with selecting a format for the MAs required by the TIM. Consolidating these formats into a usable Technical Manual is referred to as establishing a "Tech Manual's" support requirements which include consideration of access, recording mode, and display mode. Support requirements are determined on the basis of system conditions similar to those discussed above.

The remainder of the guide discusses these five steps covering the rationale, the guidelines, examples of applying the guidelines, and illustrations of the formats/media being specified.

### 1.5 Status of Selection Concept

The method for selecting formats and media presented here is preliminary. Aspects of the process such as the implementing agency and timing of the implementation need to be verified along with the guidelines which relate system conditions to formats and media. The Navy plans a shipboard test of this method. This trial application will emphasize both the feasibility and utility of the selection concept. It will attempt to identify what problems are encountered in attempting to apply the selection procedures and to answer such questions as: Do the selected formats and media improve TM utilization and maintenance effectiveness?

\* Further description of homogeneous set is given in Section 4.2, page 19.

## 2.0 GATHER MAINTENANCE ACTION AND SYSTEM CONDITION DATA

### 2.1 Introduction

Although conventional TMs have demonstrated the ability to support maintenance when the conditions of use are favorable, when the conditions become unfavorable, the conventional TM begins to lose its effectiveness. The research community has developed a variety of innovative formats and media in order to cope with these unfavorable conditions. Together, these innovations and conventional practices appear to offer an effective TM approach, but no guidelines exist to indicate when to apply conventional and when to use innovative approaches. This guide attempts to provide such guidelines so that TM formats and media can be matched to maintenance actions (MAs) and to conditions in the system to be supported. The purpose of this step is to identify the actions required to

maintain a system and to define the conditions under which these actions will be performed. The discussion below provides the guidance for accomplishing these objectives.

### 2.2 Review Task Identification Matrix (TIM)

The mechanism for indicating "when" to use various formats and media requires identification of all MAs necessary to support the system. A convenient and systematic basis for identifying MAs is the Task Identification Matrix (TIM). The key elements of a TIM (see Figure 2) are as follows:

- The TIM shows all MAs in terms of the equipment being supported;
- The TIM is prepared as a standard product of the Integrated Logistics System (ILS) process;

Topdown Breakdown / Maintenance Functions	System Operational Check	Troubleshoot	Remove	Install	Adjust	Inspect	Calibrate
SYSTEMS							
HYDRAULIC PRESSURE PRODUCTION	X						
HYDRAULIC SYSTEM NO. 1	X	X					
Check Valve							
Low Pressure Warning Switch			X	X			
Snubber							
Reservoir Vent Filter							
Case Drain Return Filter							
System Relief Valve							
Check Valve							
Flow Regulator							
Main System Return Filter							
Reservoir Drain Valve							
Drain Valve							
Suction Boost Pump							
Ground Test Line Filter							
Shut Off Valve			X	X			

Figure 2. Typical Entries in a Task Identification Matrix (TIM)

- The topdown breakdown of the hardware (left column) gives the TIM its system-specific character; and,
- The TIM is a convenient way to guarantee that the Technical Manual (TM) covers or, at least has considered covering, all MAs, an apparent short-coming of many TIMs.

Traditionally, the TIM is used with task analysis data to establish the balance between TM coverage and formal training. This version of the TIM becomes available too late in the system development process to meet format-medium selection requirements. An earlier version of the TIM is more suitable; specifically, the TIM which is prepared as a first step in preparing job performance aids (JPA's). Referring to Figure 2, the early TIM identifies MAs (cells of matrix marked with an X) in terms of maintenance functions (top row) and maintainable units of the topdown breakdown (left column).

This early version of the TIM, obtained with or without interrogation of the ILS staff, will help to establish the required MAs and the TM-relevant conditions under which the MAs will be performed. This effort is discussed below.

### 2.3 Establish System Conditions

Certain system conditions tend to indicate which formats and media should be used to present a system's maintenance information (e.g., see the personnel turn-

over example presented on page 2). All system conditions to be considered in selecting formats and media are listed in Table 1 below.

Many of the conditions in Table 1 are self-explanatory and all are discussed in subsequent steps of the guide. The purpose of this part of Step #1 is to define these conditions for the system to be supported, e.g., is automatic test equipment present? If so, what parts of the topdown breakdown are covered? To help begin this process, the following text defines some of the less obvious conditions and presents guidelines for obtaining definitions.

#### Testing Technique

This condition relates to troubleshooting MAs and can occur in either of two states: internal or external. An external state occurs when malfunction symptoms are available without shutting down the system and gaining access to its interior parts, (i.e., listen to operating sounds, read displays, observe/time part movements, etc.). Internal refers to the situations where troubleshooting requires gaining access, locating test points, setting up test equipment and interpreting test outcomes.

One state may apply to part of the system (e.g., external applies to the Organization level of maintenance) while the other state applies to the remainder (e.g., internal for Intermediate or Shop maintenance). Determining which condition state applies to which

Table 1  
System Conditions Affecting Formats and Media

Task	Personnel	Hardware	Workspace
Troubleshooting	Turnover	Automated Test Equipment	Illumination
Remove and Replace	Time to Proficiency	Status Displays	Space
Testing Technique	Span of Supervision	Distribution	Elements (Rain)
Special Case Actions	Personnel Qualification Standard	Size	Cleanliness
<ul style="list-style-type: none"> <li>• SOP</li> <li>• 1 Trial</li> <li>• Calibration</li> <li>• Hazardous</li> <li>• Periodic</li> </ul>	General Classification Test (GCT)	Readiness Impact	
	Job Scope	Subordination	
		Maintenance Demands	
		Replication	
		Installation Context	

parts of the system is largely a function of hardware features and maintenance analysis results available from design engineering sources.

#### **Special Case Actions**

This guide provides procedures for matching formats and media to MAs. In many cases the match is a function of the conditions related to MA performance. In other cases the match is constant, not influenced by conditions. Special Case actions are in the constant category. The TIM serves as the means to identify those MAs which fall into the Special Case categories listed below. Definitions of these actions and their associated formats are discussed extensively in the next section of the guide.

- Standard operating procedure (SOP)
- One trial learning MA
- Calibrate, adjust, align MA
- Time critical, hazardous MAs
- Periodic MAs

#### **Personnel Qualification Standards (PQS)**

A system may or may not involve PQS which establishes skills and knowledges necessary for technicians to qualify for various watch standing duties. The presence (or absence) of PQS has definite format implications, especially in the knowledge categories, e.g., functional purposes, dependencies, and signal flows of system components. Defining this state is a matter of checking personnel and training "specs" for the system.

#### **Job Scope**

This condition relates to the day-to-day responsibilities of the Ratings involved in maintaining the system. Some BTs (boilermen), for example, spend a majority of their time maintaining the control portion of a ship's propulsion system. This is a relatively narrow job scope. Other Ratings (Machine Repairman, for example) have an array of mechanical equipment to maintain which gives them a relatively broad job scope.

#### **Subordination**

The complexity of MAs is a critical concern regarding information formats. However, predicting this

complexity is very difficult, especially at the early stage of system development when format commitments are required. In this context, hardware subordination, obtained from the topdown breakdown portion of the TIM, is a reasonable predictor of MA complexity. Equipment with a subordination greater than one in ten (a judgment value) is assumed to pose complex troubleshooting problems.

#### **Maintenance Demands**

Maintenance workload is generated in "batches" or by "single event." The batch source is usually associated with multiple systems, e.g., several aircraft returning from flights; maintenance input to a repair ship. When a batch condition exists, especially in concert with inexperienced personnel, maintenance queues can build up, viz., equipment awaiting maintenance for lack of personnel. Innovative formats are especially appropriate for the batch condition but not as necessary in the alternate condition where unscheduled workload results from single system failures.

#### **Replication**

The number of system installations throughout the Navy influences the type of TM to consider (mostly the medium). Specifically, the problem of distributing TMs and changes is more severe for a system with many replications than for a system which has only a few replications. Determining which of these states applies will help to establish the TM support requirement of recording mode.

#### **Installation Context**

The context in which a system is installed relates to the recording mode used to store its TM information. This condition is especially important for small systems which may not qualify for use of microform unless the cost and capacity of microform equipment can be shared with other systems. Therefore, it is necessary to determine whether a system's installation context will be "isolated" or in the proximity of other systems (as in a shipboard installation).

### 3.0 IDENTIFY SPECIAL CASE MAINTENANCE ACTIONS

#### 3.1 Introduction

Research evidence and TM practice have shown that regardless of system conditions certain formats have proven to be cost effective for many MAs which as a group are referred to as "Special Case" MAs. The purpose of this step is to review the TIM to identify the special case MAs to which the appropriate formats will be assigned.

The "special case" actions are listed below and discussed in the following text. Each discussion defines the MA category and illustrates the prescribed formats.

- Standard Operating Procedures (SOPs)
- One Trial Learning MAs
- High Complexity MAs, viz., calibrate, adjust and align
- Time-critical, Hazardous MAs
- Periodic MAs

#### 3.2 Standard Operating Procedures (SOPs)

A standard operating procedure (SOP) is a performance sequence which supports many MAs (i.e., sequence X is to be performed prior to all checks, tests and troubleshootings of system Y). Describing SOPs fully each time they are required would be costly. To minimize cost, the treatment prescribed for SOPs is: (1) describe it once in a dual level version of a fully proceduralized format and (2) include a reference to the SOP description in each of the MAs being supported.

Typical SOPs are listed below.

- (a) Set up common test equipment
- (b) Turn on and shutdown procedures

- (c) Applying auxiliary power
- (d) Common operating sequences, e.g., switch from mode to mode.

SOPs are difficult to identify from the TIM prior to the conduct of a task analysis. Some guidelines to help identify instances where SOPs are likely are annotated below.

- MAs which require the use of standard test equipment (e.g., signal generators) are likely to include SOP sequences.
- Any MA conducted off line is a likely candidate to include SOPs (e.g., test rig setups, connection of auxiliary power).
- Components which require a standard repair action are candidate SOPs, i.e., a soldering action necessary to remove all parts from a circuit board.
- Tests and checkouts which require that the system be placed in a special condition (setup of a particular mode of operation).

Figure 3 illustrates the format to use in preparing the full description of the SOP. The rationale for using this format is that frequent performances of an SOP suggest that they be learned; however, some technicians may be performing the SOP for the first time or for the first time in quite a while. The features of the Figure 3 sample which support this situation are:

- hierarchial arrangements of tasks to facilitate learning
- phrases in the upper hierarchies to facilitate use as a checklist
- detail in the lower hierarchies to facilitate use as a job guide.

## REMOVE AND INSTALL FLOWMETER TRANSMITTER

### Install Flowmeter Transmitter

#### NOTE

All replacement flowmeters have been calibrated and filled with Amso 140, Type 2 calibration fluid (Mil-F-7024, or equivalent). The calibration fluid should be removed from all replacement flowmeters before installation onto the engine.

Lack of fluid in a flowmeter can cause damage to the jewel bearings and pivots. If the replacement flowmeter has no fluid in it, or if there is evidence that it has been jarred or dropped, it should be sent to an overhaul depot for calibration.

#### CAUTION

The flowmeter transmitter is a delicate instrument and should be handled carefully.

1. Install flowmeter onto connector (8).
  - a. Remove caplug from connector at (8).
  - b. Lubricate and install O-ring.
  - c. Using 0-150 lb. in. torque wrench, torque four bolts to 24 - 27 lb. in.
  - d. Safety wire four bolts.
2. Install connector (10)
  - a. Lubricate and install O-ring onto shoulder of connector.
  - b. Torque four bolts to 24 - 27 lb. in.
  - c. Safety wire four bolts.

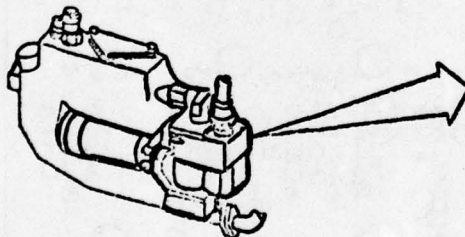

#### CAUTION

The flowmeter (7) can be damaged if the fuel connector (10) is not supported with a wrench when torquing coupling nut (9).

3. Reconnect fuel hose.
  - a. Remove caplugs PP100 and WW-19 at (9).
  - b. Lubricate connector threads.
  - c. Using 500 to 1000 lb. in. torque wrench, torque coupling nut to 650 - 750 lb. in.

#### NOTE

Do not lubricate O-ring.

4. Reconnect connector (9).
  - a. Remove caplugs EC-10 and EP-10.
  - b. Install O-ring.
  - c. Safety wire connector (8).

#### END OF ACTIVITY

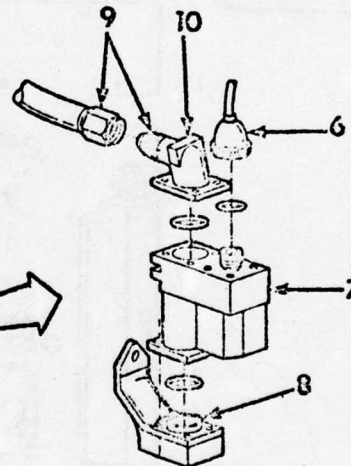

Figure 3. Format to Use in Preparing a Fully Proceduralized, Dual-Level Description of an SOP

### 3.3 One Trial Learning MAs

Design for maintainability has advanced to such a stage that many systems include a considerable number of easy-to-perform activities even to the point of where the "how to" is apparent by a quick inspection. However, the technician has information needs even for this simple class of performance. For example, removal

and replacement of plug-in units is a one trial learning MA but the technician still needs to find the general area of the unit to be replaced, and still must be able to recognize the unit. Therefore, a location diagram is required to support these types of special case MAs. Figure 4 illustrates the information format appropriate to support this type of performance.

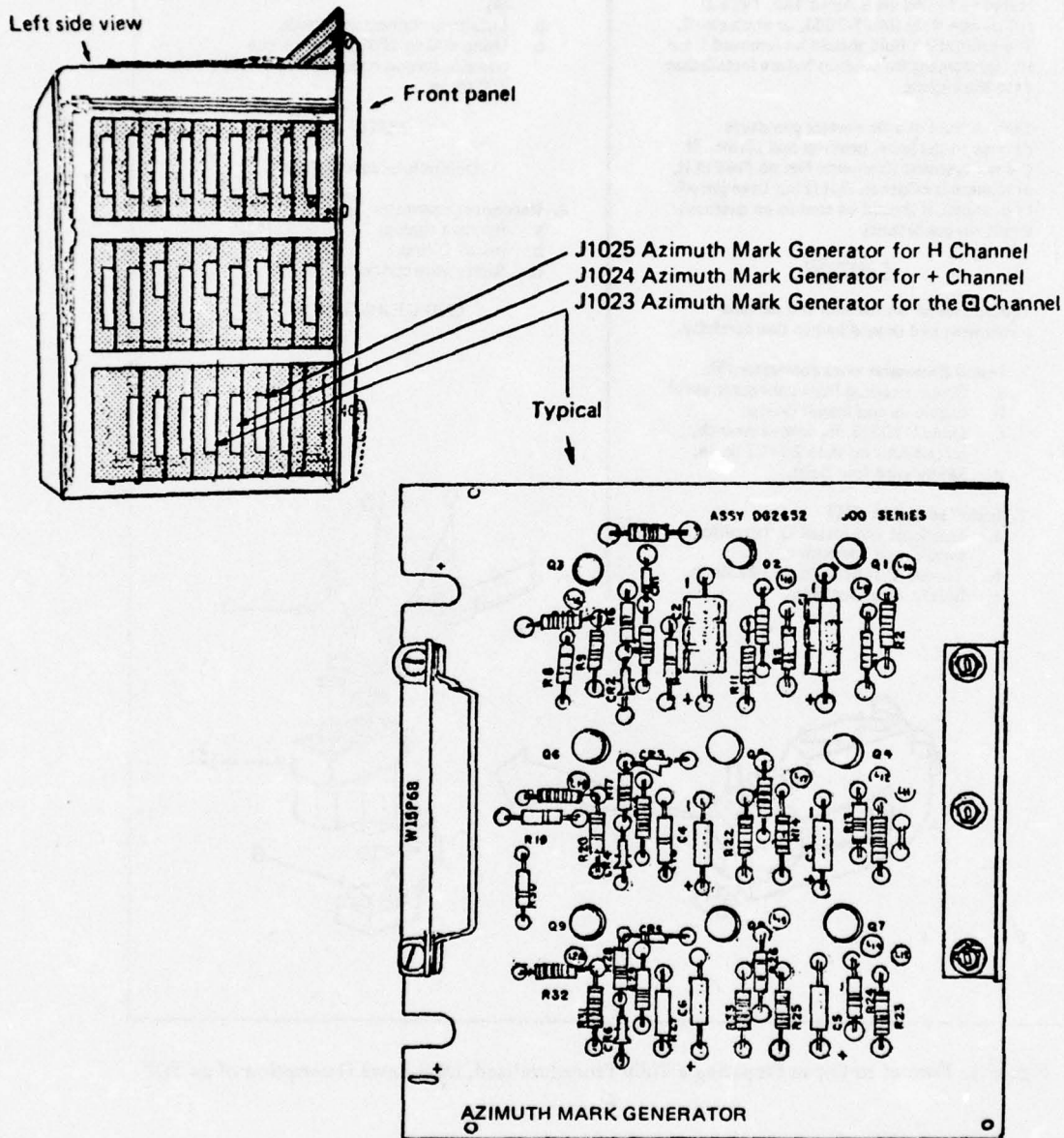

Figure 4. Location Diagram Suitable for Supporting One-Trial Learning Action.

### 3.4 High Complexity MAs

Performance evaluations of calibrations, adjustments and alignments reveal that these MAs are unusually difficult to perform. This difficulty may involve precision motor skills, coordination of inter-dependent tolerances, or the iterative form of accomplishing the action.

Whatever the cause of the complexity it is appropriate to apply a strong, performance-supporting format, namely the fully proceduralized format augmented by generous use of "training notes." Figure 5 is a sample of such a format for an adjustment action. The illustration shows the use of training notes to aid the technician in accomplishing difficult portions of the MA.

**Install and Adjust Aux Air Door Caution Light Switch**

1. Request assistant gently lift door until it is nearly closed and allows just enough room for switch wire.

**NOTE**

For proper continuity through switch leads, the multimeter needle must touch the "O" mark on the scale when door 81L is  $6.0 \pm 0.1$  inch from mold line of the aircraft. If the needle is at any other position, it indicates that the switch is out of alignment and requires adjustment.

2. Request that assistant lower door and hold so position of leading edge of door  $6.0 \pm 0.1$  inch from mold line of aircraft.
3. Check that multimeter needle touches the "O" mark on the scale with door in this position.

**NOTE**

If multimeter needle touches the "O" mark, remove switch wires from multimeter probes and go to page 15. If needle is at any other position, go to page 12.

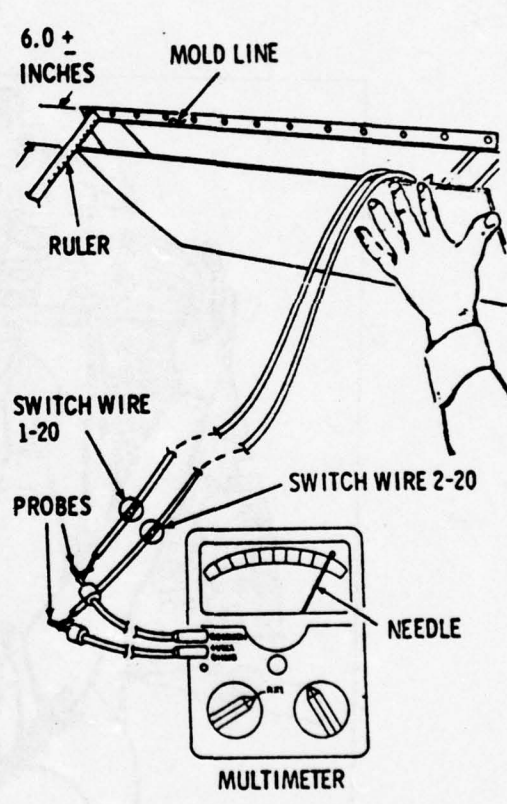

The diagram shows a hand holding a ruler against a mold line on an aircraft structure. A door is being adjusted. Two switch wires, labeled 'SWITCH WIRE 1-20' and 'SWITCH WIRE 2-20', are connected to the probes of a multimeter. The multimeter's needle is shown pointing to the 'O' mark on its scale. Labels include '6.0 ± INCHES', 'MOLD LINE', 'RULER', 'SWITCH WIRE 1-20', 'PROBES', 'SWITCH WIRE 2-20', 'NEEDLE', and 'MULTIMETER'.

Figure 5. Proceduralized Format Emphasizing "Training Notes"  
Intended to Support Unusually Complex MAs

### 3.5 Time Critical, Hazardous MAs

Many operator and technician actions must be performed rapidly and precisely to prevent damage to equipment or injury to personnel. Technicians performing these actions do not have time to rely on job guides or checklists to aid their performance; they must know without hesitation what to do and how to do it.

Actions of this type will be stressed in training but opportunities to practice/perform these MAs are rare.

Therefore, the TM can help by including performance descriptions in a fully proceduralized format which emphasizes pictorial representations of the steps involved. The rationale for the use of this format is that pictorials are less ambiguous and easier to remember (and rehearse) than their narrative counterparts.

Figure 6 illustrates the format recommended for these applications. The sample emphasizes the use of pictorials in describing user actions, especially those which involve unusual manipulations.



Figure 6. Pictorial Emphasis in a Format to Support Time-critical, Hazardous Actions

### 3.6 Periodic Maintenance

The majority of preventive maintenance is done periodically, (e.g., weekly, daily) or at least on the basis of regular events (e.g., 1000 hour check, once for every cruise longer than 48 hours). The positive effect which this regularity characteristic has on proficiency is countered somewhat by the usually lengthy performance sequences involved.

Experience has shown that providing a modest amount of detail in the description of these procedures satisfies the technician's need for guidance. The suggested format for such a description relies heavily on narrative statements of performance. Figure 7 illustrates a representative sample of the format that should be used in describing these actions.

<b>COMPONENT/SYSTEM</b> FUEL OIL STRAINER, DUPLEX		<b>C.P. NO.</b> FODS
<b>C.P. DESCRIPTION</b> SHIFTING, INSPECTION, CLEAN, OPERATING	<b>RATE</b> PO3	<b>TIME</b> 10 MIN.
<p><b>PROCEDURE</b></p> <ol style="list-style-type: none"> <li>11. Remove strainer basket from idle strainer chamber.</li> <li>12. Inspect basket for foreign matter.</li> <li>13. Clean strainer basket dry with low pressure air.</li> <li>14. Blow strainer basket dry with low pressure air.</li> <li>15. Inspect strainer basket for cracked or broken mesh.</li> </ol> <p><u>NOTE:</u> Renew if required.</p> <ol style="list-style-type: none"> <li>16. Remove cap gasket from idle strainer chamber.</li> <li>17. Inspect cap gasket for:             <ol style="list-style-type: none"> <li>a. Cracks</li> <li>b. Breaks</li> <li>c. Deterioration</li> </ol> </li> </ol> <p><u>NOTE:</u> Renew if required.</p> <ol style="list-style-type: none"> <li>18. Reinstall cap gasket.</li> <li>19. Reinstall basket.</li> </ol> <p><u>CAUTION:</u> <u>ENSURE STRAINER CAP IS PROPERLY SEATED.</u></p> <ol style="list-style-type: none"> <li>20. Reinstall cap.</li> <li>21. Shut drain valve on idle strainer chamber.</li> </ol> <p><u>CAUTION:</u> <u>BOTH STRAINERS ARE PRESSURIZED WHEN SHIFT LEVER LOCKING DEVICE IS RELEASED.</u></p> <ol style="list-style-type: none"> <li>22. Test and vent idle strainer chamber as follows:             <ol style="list-style-type: none"> <li>a. Crack open vent valve on idle strainer.</li> <li>b. Release shift lever locking device.</li> <li>c. Shut vent valve on idle strainer when oil flow appears.</li> </ol> </li> </ol>		

Figure 7. Sample Format for Describing Periodic MAs

## 4.0 SELECT FORMATS FOR PRESENTING TROUBLESHOOTING INFORMATION

### 4.1 Available Formats

Figure 8 indicates the four format options available to support troubleshooting actions. The fully proceduralized format on the left is characterized by high preparation cost, minimum training requirements and early performance capability for the user. The system description option on the far right costs relatively less to prepare but requires lengthy and only partially productive learning periods in advance of and during job assignment. Samples of each format option are shown in Figures 9 through 12. The purpose of this step is to select the most cost-effective options for supporting the troubleshooting actions of a system.

### 4.2 Selection Process

The selection process involves analysis of system conditions and consideration of format cost. The selection is represented by the four tasks listed and discussed below.

1. Identify format candidates for homogeneous sets of troubleshooting actions.
2. Compare the costs of candidate formats.
3. Consider relevant system conditions to:
  - (i) verify or override the candidate format which has an obvious cost advantage; or
  - (ii) indicate best choice where no candidate has an obvious cost advantage.
4. Make final format selection.

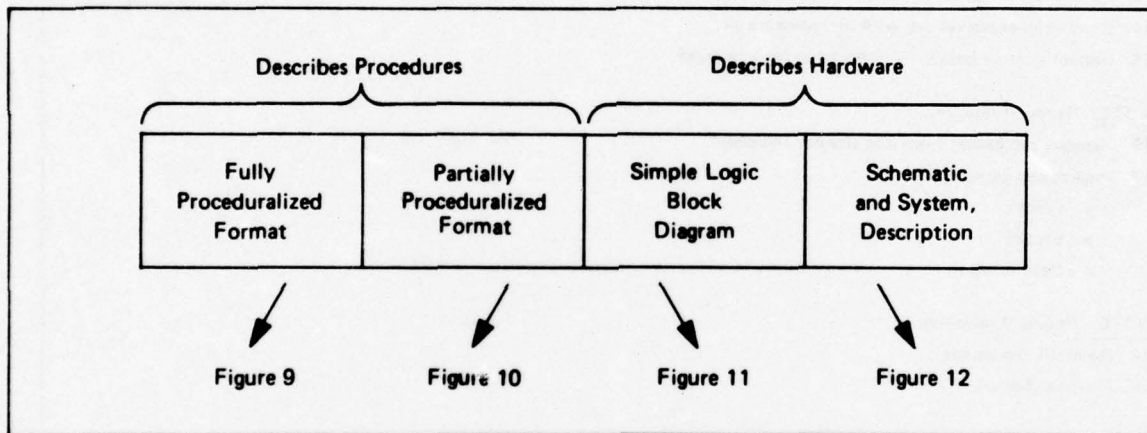

Figure 8. Formats Available to Present Information to Support Troubleshooting

## CAMERA TROUBLESHOOTING

### Shutter Will Not Open, UV Lamp (Blue Light) Flash Normal

1. Set meter mode switch (4) to -DC and meter range switch (5) to 2.5V. Connect meter probe (2) to point (7). Meter (6) should indicate greater than 0.5.
2. If meter (6) indicates less than 0.5, replace resistor R12 (9). If meter (6) indicates greater than 0.5, disconnect camera power plug from wall receptacle.
3. Disconnect meter black test lead (3) from point (10) and set meter range switch (5) to R x 10,000.
4. Clip black test lead (3) to the tip of the red test lead (2). Adjust multimeter ZERO OHMS control (1) until meter needle indicates 0, on right of scale.
5. Connect meter black test lead to point (10). Connect meter probe to point (7). Meter (6) should indicate less than 1.8 on top scale.
6. If meter (6) indicates less than 1.8, replace transistor Q12 (11). If meter (6) indicates greater than 1.8, replace resistor R16 (8).

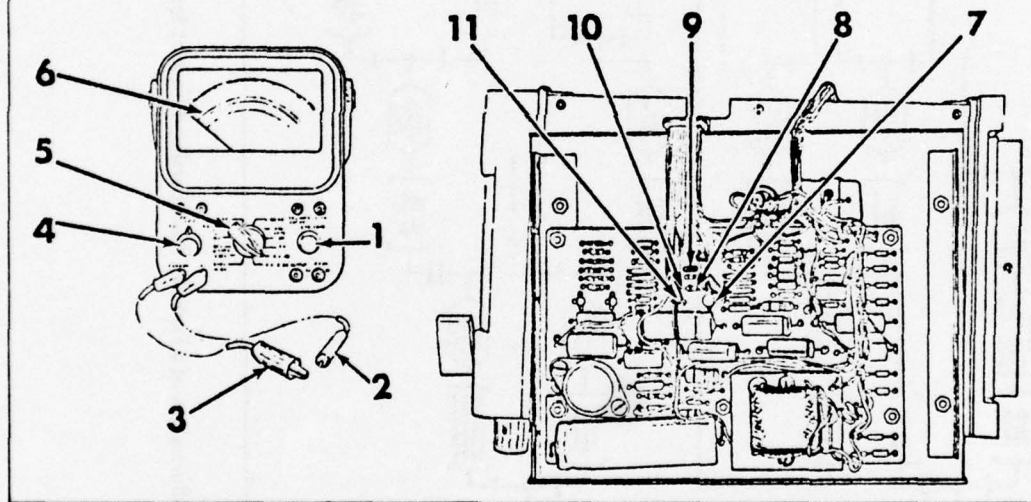

Figure 9. Illustration of a Fully Proceduralized Format for Presenting Troubleshooting Guidance



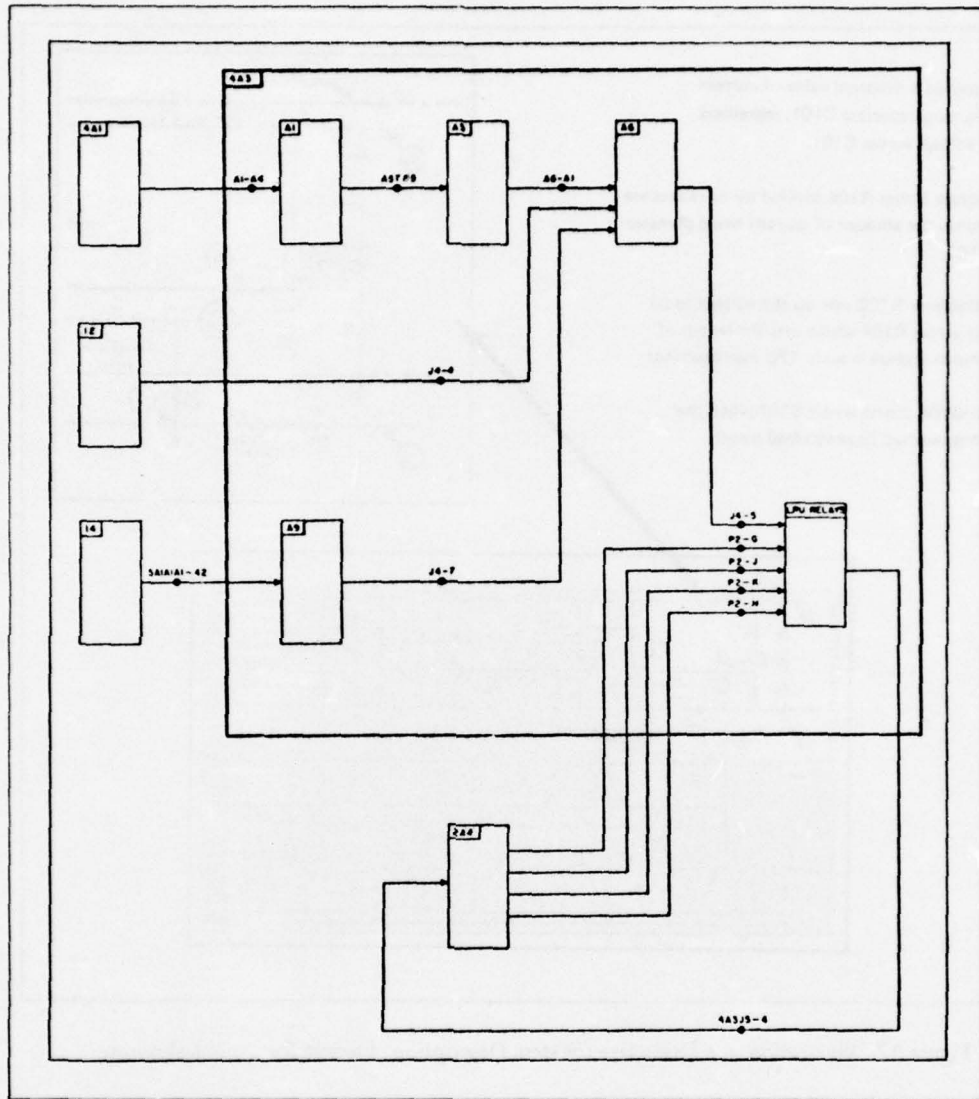

Figure 11. Sample of a Deductive (Simple Logic) Format for Troubleshooting



**4.3 Task #1. Identify Format Candidates for Homogeneous Sets of Troubleshooting Actions**

Table 2 presents the system conditions which influence the type of format to use in supporting troubleshooting actions. In order to select the best format, one can consider each of the many troubleshooting actions of a system against these conditions, or one can consider sets of troubleshooting actions which share the same conditions. MAs performed under the same conditions are referred to as homogeneous sets of MAs.

Figure 13 presents part of a hypothetical topdown breakdown. It will be used to illustrate the role which the concept of homogeneous MAs plays in selecting troubleshooting formats. Assume that the troubleshooting of systems 1, 2 and 3 is the responsibility of a BT (Boilerman) while an MR (Machine Repairman) troubleshoots malfunctions in system 4. The BT responsibility indicates that the personnel conditions of turnover, time to proficiency, GCT and span of

supervision are likely to be the same for systems 1, 2 and 3, thereby qualifying their troubleshooting actions as a candidate homogeneous set. The personnel conditions for troubleshooting system 4 will be different from those of systems 1, 2 and 3. Thus, its troubleshooting actions are candidates for a second set of homogeneous MAs.

Continuing this illustration, assume that the subordination of system 1 is 1 to 17 while the subordination of systems 2, 3 and 4 is 1 to 5 or less. The 1 to 17 subordination of system 1 sets its troubleshooting action apart from those of systems 2, 3 and 4 giving system 1 a homogeneous set status. Assuming that the remaining conditions are as shown in Figure 13 the result is that there are three homogeneous sets of troubleshooting actions: system 1; systems 2 and 3; and system 4. In a subsequent task in this guide the particular system conditions for each homogeneous set of troubleshooting actions will be considered to determine how they influence format selection.

Table 2  
Summary of Conditions Affecting Troubleshooting Format

Conditions	State/Format Indications	
	Proceduralized	Deductive
Subordination	> 10	< 5
Readiness Impact	Down or degraded	No effect
Diagnostic Technique	Internal	External
Personnel Turnover	High	Low
Time to proficiency	Long	Short
Maintenance Demands	Batch	Single Event
General Classification Test (GCT)	Low	High
Span of Supervision	High > 10	Low < 3
Personnel Qualification Standards	Not required	Required

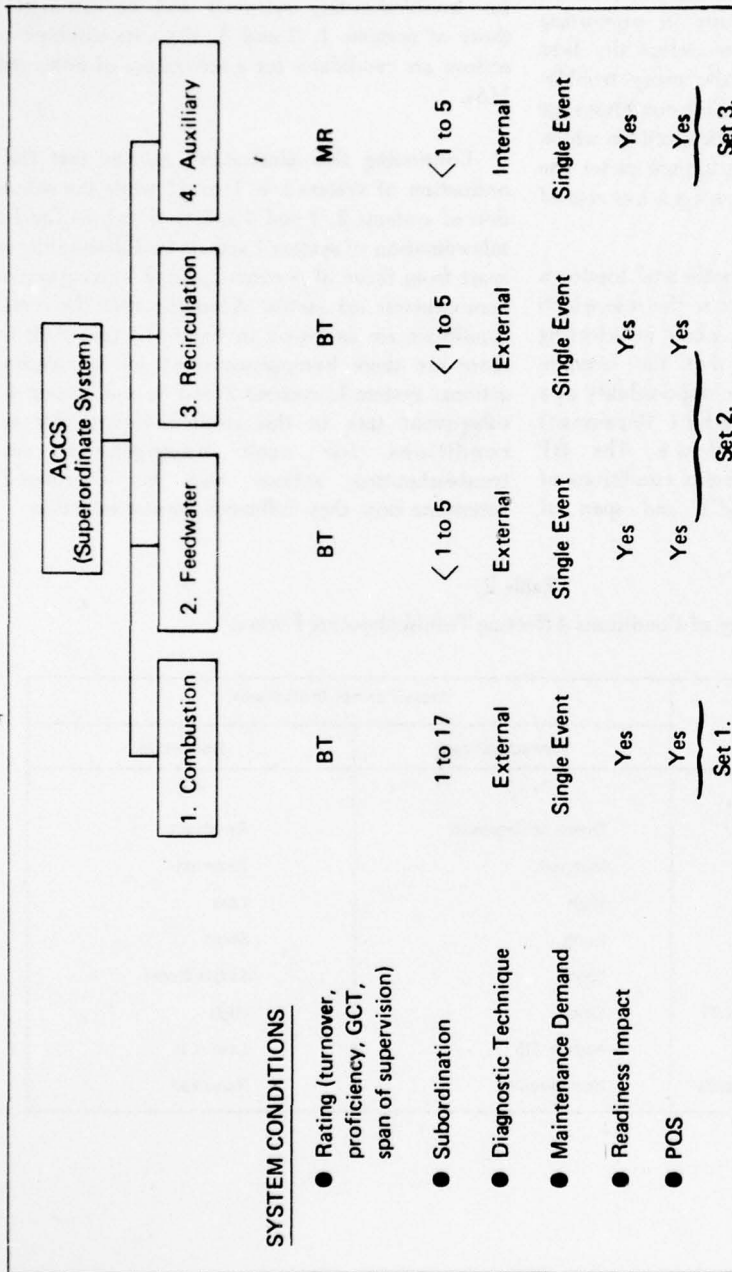

Figure 13. Topdown and System Conditions to Illustrate Homogeneous Sets of MAs

#### 4.4 Task #2. Compare Costs of Deductive and Proceduralized Formats

All four formats illustrated in Figure 8 are not equally appropriate for all homogeneous sets of troubleshooting actions. For example, the simple logic version of the deductive format is not particularly well suited to supporting troubleshooting at the piece part level of a system. Therefore, the first purpose in this task is to exclude candidate formats which do not apply to the homogeneous sets chosen above.

The selection of a particular format option should be based on its cost and its compatibility with the anticipated system conditions. The second purpose of this task is to estimate costs for preparing competing formats. The basis for preparing these cost estimates is the complexity of the troubleshooting problem as represented by the number of suspect components (viz., subordination).

*Guidelines.* Guidelines for preparing cost estimates are presented below for each of the four format options.

- (1) Deductive; Simple Logic Diagram
  - \$50 per subordinate unit
- (2) Deductive; System Description
  - ½ page of narrative per subordinate unit (maximum of 4 pages)
  - \$200 per page of narrative
  - \$75 per subordinate unit for schematic
- (3) Partially proceduralized
  - 2 steps per subordinate unit
  - cost = cost of system description (from 2 above) + \$20 per step
- (4) Fully proceduralized
  - 2 steps per subordinate unit
  - cost = cost of system description (from 2 above) + \$50 per step

*Example.* Applying the cost guidelines to the case of the Feedwater Control System (see Figure 14) gives the following results.

- (1) Deductive, simple logic version.
  - \$50/subordinate unit

- 9 subordinate units @ \$50 ea. = \$450 (~500)

#### (2) Deductive, system description

- ½ page of narrative for each of 9 subordinate units (maximum of 4 pages). 4 pages x \$200 = \$800.
- schematic with 9 subordinate units @ \$75/unit = \$675
- total cost for system description + schematic = 800 + 675 = \$1475 (~1500.00)

#### (3) Proceduralized, partial

- 2 steps per subordinate unit
- 9 subordinate units x 2 steps = 18 steps
- cost = cost of deductive system description + 18 steps x \$20/step = 1475 + 360 = 1835 (~\$1800)

#### (4) Proceduralized, fully

- 2 steps per subordinate unit
- cost = cost of deductive system description + 18 steps x \$50/step = 1475 + 900 = \$2375 (~2400).

#### 4.5 Task #3. Consider System Condition Indicators

System conditions indicate which of the four troubleshooting format candidates will be most effective. Table 2 summarized nine of these conditions. The strategy to use in selecting the best format is: assume that the deductive approach will be used unless the various system conditions indicate that a proceduralized approach is warranted.

Each of the conditions of Table 2 is discussed below, with definitions of terms and identification of formats implied by the states of each condition.

(1) *Subordination.* At this early stage of system design, subordination, the number of components which could be causing a malfunction, is a reasonable indicator of troubleshooting complexity. Timely and accurate troubleshooting is possible with the deductive format assuming that the technician, no matter how inexperienced, has received some training, and that the

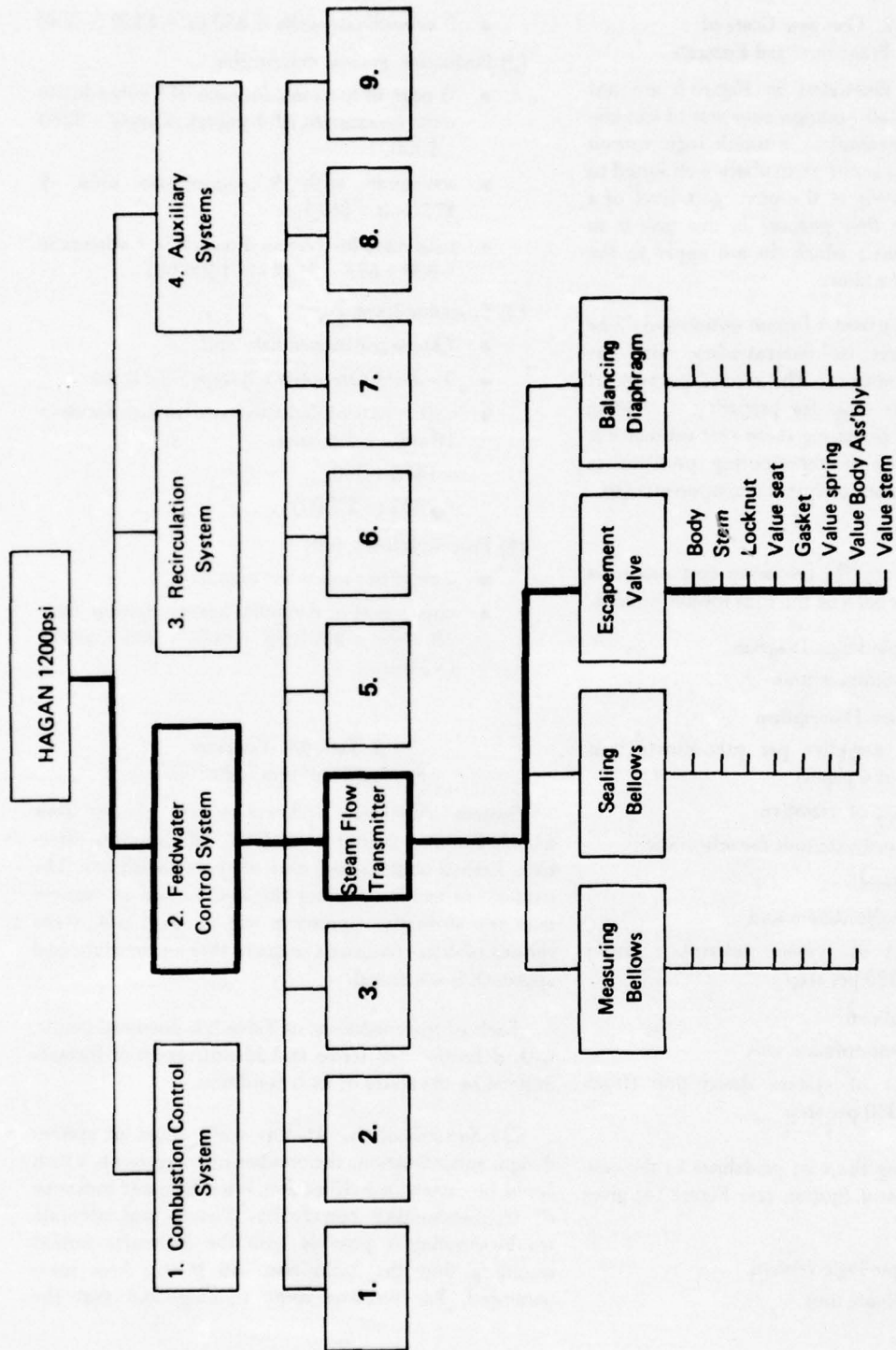

Figure 14. Topdown Breakdown (Partial) to Illustrate Cost Estimations.

nature of the troubleshooting is not too complex. In considering this hardware-oriented condition . . .

Use the proceduralized format when troubleshooting involves isolation to one of more than 10 subordinate units.

Prior to considering proceduralized formats, the topdown breakdown should be reviewed to ensure that a large subordination (>20) is valid. Such a condition is sometimes an artifact, the result of improper consideration of functions. For example, Figure 15 lists the piece parts which make up the Flow Transmitter. The figure shows 54 parts, indicating a 1:54 subordination. However, 1:4 is a more reasonable subordination as indicated in the Topdown Breakdown in Figure 14 (used to illustrate cost estimation).

(2) *Readiness Impact.* Some hardware designs include backup or alternate modes of operation. In such cases primary hardware failures do not put the system "out of commission." Similarly, troubleshooting performed beyond the Line or Organizational levels does not have immediate, adverse effects on prime system readiness. In other cases, primary hardware failure halts operation of the entire system or jeopardizes mission effectiveness. The intent of this condition regarding troubleshooting formats is . . .

Consider the proceduralized aid format when the operational hardware will be out of commission during the troubleshooting process.

For unusually critical cases of readiness impact, a variation of the proceduralized format is the "quick fix" method described in reference 1. In this approach, symptom-cause data from all fleet failures are pooled and analyzed to identify those failures that consistently produce the same symptom.

(3) *Diagnostic Technique.* Some troubleshooting sequences are quite lengthy, requiring that the technician gain access, locate test points, set up test equipment, assess test outcomes and repeat the process for the next test sequence. Other sequences are less time-consuming, relying on external symptoms and standard operating sequences. In considering this condition . . .

Use the proceduralized format where the "internal" technique will be required.

(4) *Personnel Turnover.* A personnel turnover condition is considered high when 50% or more of the workforce can be expected to leave in a calendar year. This state implies a minimum front end training investment for entry level technicians. In considering this condition . . .

Use the proceduralized troubleshooting format in a high turnover condition since it requires relatively small amounts of preparatory training. Where turnover is lower, greater amounts of career-related training are justifiable permitting greater use of deductive troubleshooting aids.

(5) *Time to Proficiency.* Effective manpower utilization demands minimum time to proficiency on all tasks especially the more difficult troubleshooting performances. In applying this condition . . .

Use a proceduralized troubleshooting format in cases where time to proficiency exceeds 1/3 of the usual tour length. Conversely, a short time to proficiency indicates that personnel can perform well with the deductive troubleshooting format.

In some cases personnel turnover combines with time to proficiency to indicate a need for a combination of the two troubleshooting formats. Specifically, a lengthy proficiency period (indicating complex performances) can occur with a low personnel turnover (indicating a user need to acquire career-relevant skills). This combination of conditions indicates a need for both formats keyed to each other. The proceduralized element: (1) lets the new technician be a productive member of the workforce and (2) teaches the new technician how to troubleshoot using the deductive element. This combination of aid types is illustrated in Figure 16 and described in detail in reference 2.

Four additional system conditions and their implications for deductive or proceduralized troubleshooting formats are summarized below. The impact of these final four conditions is not as strong as the first five conditions. Accordingly, these conditions should be used to reinforce format implications discussed above or to resolve "ties."

*Maintenance Demands.* Maintenance workload which occurs in batches (e.g., recovery of flight of aircraft or Repair Ship receipt of deferred maintenance actions) suggests proceduralized aids to support troubleshooting.

Item 4A. B: Model "53N" Flow Transmitter with Variable Element: Drawing 539675				
14	Diaphragm Plate Assembly	1	3	138551
15	Diaphragm	1	3	9351-1
16	Diaphragm Seat	1	3	138547
17	Connecting Rod	1	3	138546
19	"O" Ring	1	3	120039-8
20	Spring	1	3	S-159
21	Cam Mounting Bracket	1	3	338570
23	Cam Roller Lever Assembly	1	3	183557
24	Ball Bearing	5	15	122548
25	Retaining Ring	2	6	120133-3
27	Spacer	2	6	138561
28	Spacer	1	2	138562
32	Bearing Pin	2	6	138558
33	Retaining Ring	4	12	120140-9
34	Flow Cam	1	3	138576
36	Clevis	1	3	138544
37	Coupling	1	3	138545
39	Loading Spring	1	3	138552
40	Loading Spring	1	3	3-387
41	Escapement Valve Body	1	3	10303-5
42	Valve Stem	1	3	10303-6
43	Lock Nut	1	3	10303-7
44	Valve Seat	1	3	10303-8
45	Gasket	1	3	10303-10
48	Beam Assembly	1	3	341250
49	Spring Adjustment Assembly	1	3	140977
50	Nut	1	3	140974
51	Valve Spring	1	3	S-321
53	No. 6-32 Elastic Stop Nut	2	6	120033-1
60	Adjustment Screw	1	3	140987
61	Adjustment Screw	1	3	142181
63	Zeroing Spring	1	3	148622
64	Thrust Plat	1	3	142399
65	Reducing Ring	1	3	142400
66	Gasket	1	3	142401
80	Lower Diaphragm Plate Assembly	1	3	246706
81	Upper Diaphragm Plate	1	3	346704
82	Bellow Assembly	2	6	146690
83	Gasket	2	6	141245
84	Gasket	2	6	141242
89	Gasket	1	3	141247
95	Pivot Pin	1	3	141256
96	Spacer	2	6	138229
97	Ball Bearing	2	6	138251
98	Retaining Ring	2	6	120133-2

Figure 15. Part Breakdown from Current TM



**GCT.** The instruction-following abilities of the lower GCT Ratings permit adequate troubleshooting performance on even the most difficult problems when supported with proceduralized formats. Thus, proceduralized troubleshooting formats should be used only in cases where GCT scores are in the low ranges.

**Span of Supervision.** Low spans of supervision (viz., 2 or 3 workers per supervisor) means that the supervisor participates in technical work either directly or by supporting less experienced technicians. These cases suggest the use of deductive aids to support troubleshooting since the supervisor is available to guide inexperienced technicians if needed. Higher supervisory spans mean more administrative duties for the supervisor and less time available to help junior technicians. Therefore, a proceduralized format is indicated.

**Personnel Qualifications Standards (PQS).** The selection of a format to support troubleshooting actions should consider PQS which presents skill and knowledge requirements to qualify technicians for various watch-standing duties. If PQS is required on a system, a technician must demonstrate mastery of certain knowledges typically included in a deductive format (e.g., functions, dependencies, signal flow). Therefore, a requirement for PQS indicates that one of the deductive versions should be used to support troubleshooting, either instead of or in addition to one of the proceduralized formats.

#### 4.6 Task 4. Make Final Format Selection

As described above, system conditions help to choose the basic format approach (proceduralized or deductive). These same system conditions serve to indicate the appropriate level of the deductive or proceduralized approach. This contribution is based on the "strength" or number of conditions favoring a particular format. For example, if the indicators are overwhelmingly "proceduralized," a fully proceduralized approach is warranted. On the other hand, an even split could indicate the "simple logic deductive" or "partially proceduralized" format. The decision to choose a particular version of the two basic formats is judgmental.

**Sample Application of Selection Process.** The circled entries of Table 3 present the system conditions that might be expected for troubleshooting a hypothetical piece of hardware. The primary system conditions are 3 to 2 in favor of the deductive approach while the secondary conditions favor the same choice by 3 to 1. Taken as a whole, the conditions lean towards the initially-assumed and less expensive deductive format. However, the three proceduralization approach indicators (subordination, proficiency and GCT) are strong enough to warrant consideration of the partially proceduralized format. Additionally, the particular combination of time to proficiency (lengthy) and personnel turnover (low) suggest combining both approaches into one format (see discussion of time-to-proficiency).

The final choice is between three formats: deductive (simple logic); partially proceduralized; and, both formats in a combined approach. Cost of these three candidates should be an additional consideration in resolving the choice. Assuming a subordination of 1:17, the cost estimates are as follows.

##### Partially Proceduralized

2 steps/subordinate unit =  $2 \times 17 = 34$   
 Cost @ \$20/step =  $20 \times 34 = \$680$   
 System description cost = \$2075  
 $\$2075 + \$680 = \$2755$  (~\$2800)

##### Simple Logic Diagram

17 subordinate units @ \$50/unit  
 $17 \times 50 = \$850$  (~\$900)

##### Combined Approach

Partially proceduralized = \$2755  
 Simple Logic Diagram = \$ 850  
 \$3605 (~\$3600)

The rationale for selecting a format is as follows.

**Partially Proceduralized.** The major objection to using only this format is its failure to address the PQS needs, viz., the user's need to learn the functions, dependencies and signal flows of the hardware items. The considerable cost of this format (\$2800) tends to be justified by its potential to reduce "front end" training costs and still achieve early performance capability. This argument is not conclusive, however, because the LOW

personnel turnover suggests that the training costs are merely postponed rather than eliminated. On balance this format by itself does not appear to be a strong contender.

Simple Logic Diagram. The condition of time to proficiency (long) works against the selection of this format option, viz., it is not certain that junior technicians could perform troubleshooting on the basis of this job aid. The span of supervision condition (low span) softens this disadvantage by having the supervisor available to guide the junior technician. In addition, the format does address the user's knowledge requirement (PQS). In summary, these advantages and its relatively low cost make it a genuine candidate marred only by uncertainty regarding performance capability of junior

technicians and the need for substantial front end training.

Combined Approach. This candidate is more expensive than its competitors. Its advantages are that it resolves the performance uncertainty question; and it addresses the PQS knowledge requirements on-the-job rather than in non-productive, classroom settings. Training costs are reduced somewhat by having the TM accomplish some of what heretofore had been formal classroom training or over-the-shoulder OJT. Qualitatively, the reduction in training costs appears to offset the extra preparation cost. When added to the PQS and early performance advantages the most cost effective approach is the combined format.

Table 3  
Example of Applying System Condition Indicators  
to the Problem of Selecting a Format for Presenting Troubleshooting Information

Conditions	State/Format Indications	
	Proceduralized	Deductive
Subordination	>10	<5
Readiness Impact	Down or degraded	No effect
Diagnostic Technique	Internal	External
Personnel Turnover	High	Low
Time to proficiency	Long	Short
Maintenance Demands	Batch	Single Event
General Classification Test	Low	High
Span of Supervision	High > 10	Low < 3
Personnel Qualification Standards	Not required	Required

## 5.0 SELECT FORMATS FOR PRESENTING REMOVE AND REPLACE INFORMATION

### 5.1 Available Formats

Figure 17 identifies three format options available to support remove and replace (r & r) performance, the predominant repair approach in many systems. The fully proceduralized format minimizes the amount of training required to qualify new technicians to perform and enables immediate performance by even the least experienced technician. However, the cost of preparing information in these formats is relatively high.

Representing the other extreme in Figure 17 is the component description format which is less expensive than its proceduralized counterparts especially if it is assigned other uses (e.g., to support troubleshooting or Personnel Qualification Standards). However, the level of performance obtained with this format is apparently low, counter-balancing its cost advantage. Samples of each of these format options are presented in Figures 18, 19 and 20,

### 5.2 Selection Process

In this activity, cost and system conditions are considered to select the most suitable format option for r & r actions. The steps of the selection process are presented below and discussed in the following text.

- (1) Select homogeneous sets of Remove and Replace actions
- (2) Compare costs of preparing the candidate formats
- (3) Consider system conditions to:
  - (i) verify or override use of a candidate with a cost advantage;
  - (ii) indicate best choice where no candidate has a cost advantage
- (4) Make final format selection

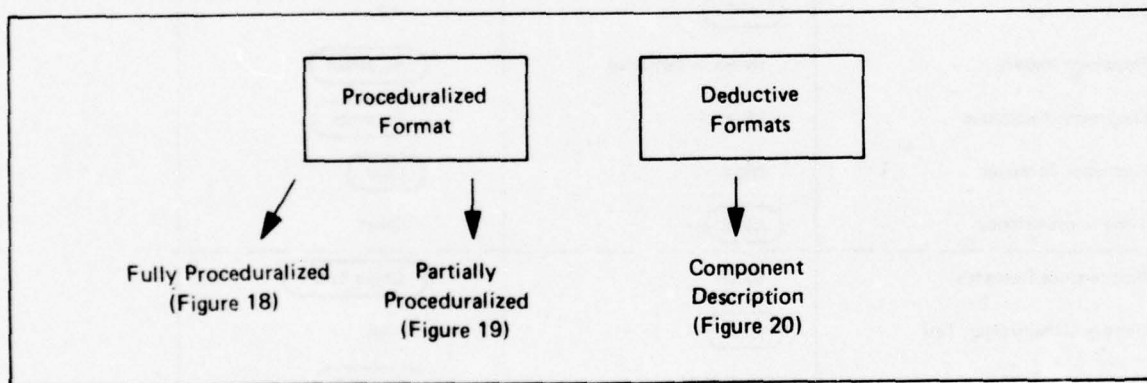

Figure 17. Formats Available for Presenting Information to Support Remove and Replace Actions

1. Remove four locknuts. Hold filter in place.

**NOTE**

Prepare to catch trapped oil in drip pan.

2. Pull main oil filter element out of housing. Discard O-ring.

3. Take filter element to shop for inspection.

**END OF ACTIVITY**

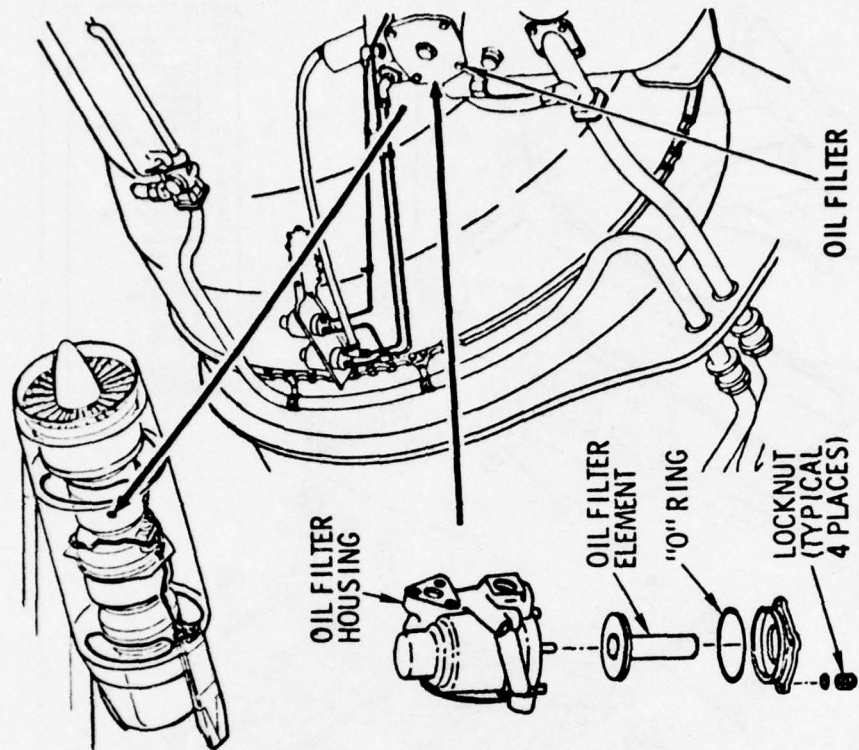

Figure 18. Sample of Fully Proceduralized Format for Supporting Remove and Replace Actions

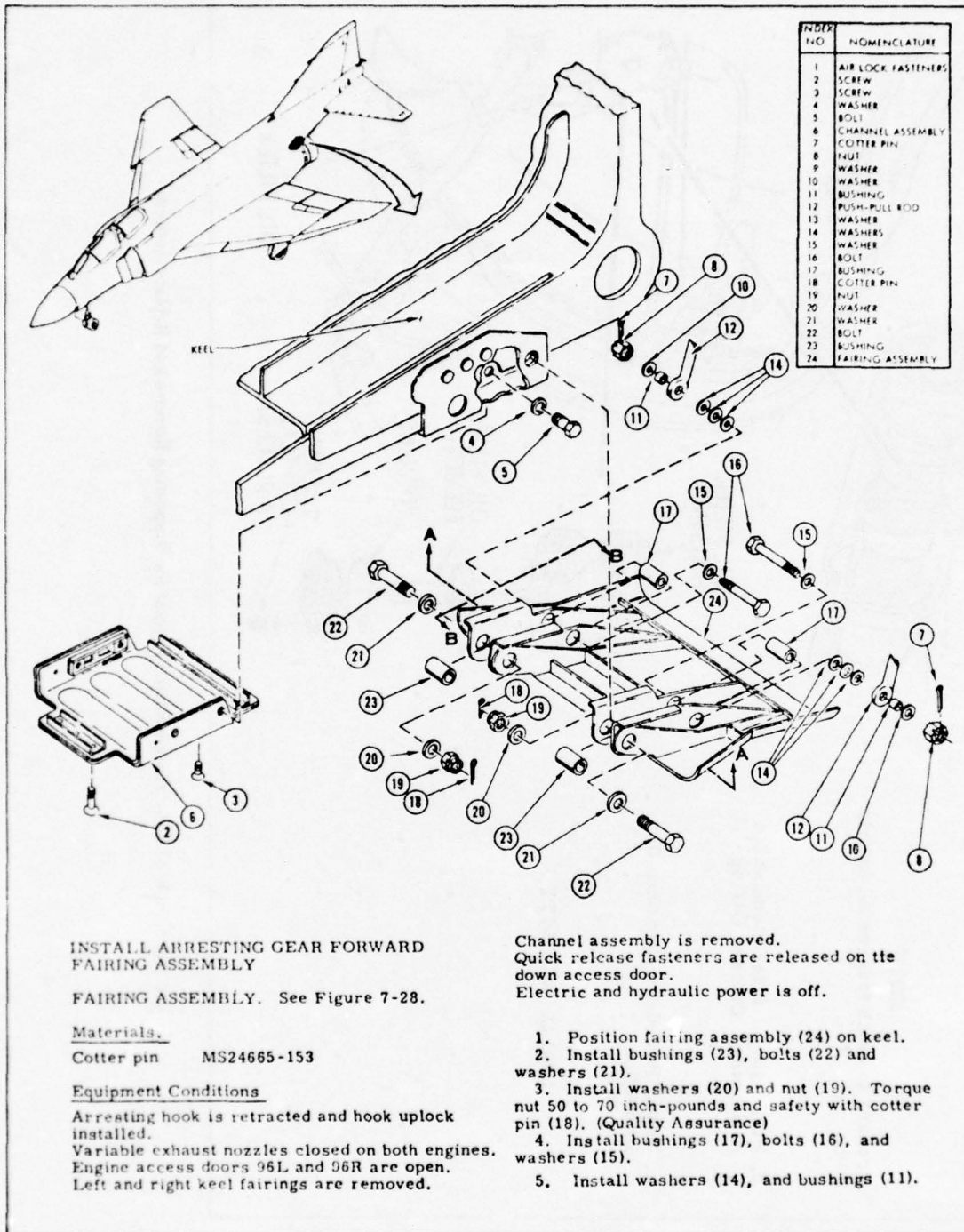

Figure 19. Sample of Partially Proceduralized Format for Supporting Remove and Replace Actions (Drawing supports other MAs)



### 5.3 Task #1. Select Homogeneous Set of Remove and Replace Actions

A homogeneous set of remove and replace actions is one in which the same system conditions apply to all removal and replacement actions. The concept is the same as that described in the troubleshooting section, although the conditions relevant to the remove and replace actions are different. These conditions and their states (see Table 4) should be compared against the maintainable units of the topdown breakdown in order to derive homogeneous sets of remove and replace actions as described in the troubleshooting step.

### 5.4 Task #2. Compare Cost of Deductive and Proceduralized Formats

Technician performance of a homogeneous set of remove and replace actions can be supported by either the procedural or deductive formats illustrated in Figure 17. The selection of one of these format options is to be based on its cost and its compatibility with the conditions expected in the system. The purpose of this step is to establish rough cost estimates for the competing formats. The basis for preparing these cost estimates is the number of components to be replaced (viz., subordination). The guidelines for preparing cost estimates are presented below for each of the three format options.

#### Fully Proceduralized

- Each action averages 20-25 steps.
- Each frame/page contains about 10-12 steps.
- Average cost of proceduralized descriptions is \$20 per page. This covers instruction steps only.
- Pictorials to support a page of instructions average 2 line drawings and an exploded view. This cost estimate is \$100 per frame of instructions.

#### Partially Proceduralized

- Each action averages about 10 steps per action.
- Each frame/page contains about 30 steps.
- Average cost of proceduralized instructions is \$30 per page. This cost covers instruction steps only.

- Cost estimates for the exploded view pictorials are \$1000 each.

#### Deductive Format

- Deductive coverage for each subordinate unit consists of system descriptions averaging ½ page of narrative (maximum of 4 pages) and one full page graphic (cutaway).
- Deductive cost guidelines are:
  - \$200 per page of narrative
  - \$1000 per full page graphic (cutaway)

*Example.* The Steam Flow Transmitter (used in previous illustrations) consists of 54 piece parts contained in approximately 5 functional units (assemblies). The procedure for removal and replacement of the piece parts can be inferred from a deductive format (system descriptions) or obtained from a proceduralized treatment. The costs for each format approach are estimated below using the guidelines presented earlier.

#### Fully Proceduralized:

- 54 piece parts about 2/3 of which might be replaced = 36 pieces x 2 (one removal and one replacement) = 72 actions
- 72 x 20 steps = 1440 steps
- $\frac{1440 \text{ steps}}{12 \text{ steps/page}} = 120 \text{ pages}$
- Instruction costs = \$20 x 120 pages = \$2400
- Pictorial costs = \$100/page x 120 pages = \$12,000
- Total cost = \$14,400 (~\$14,000)

#### Partially Proceduralized (with an IPB-type graphic)

- 54 piece parts about 2/3 of which might be replaced = 36 x 2 (one removal and one replacement) = 72 actions
- 72 x 10 steps = 720 steps
- $\frac{720 \text{ pages}}{30 \text{ steps/page}} = 24 \text{ pages}$
- 24 pages @ \$30 per page = \$720 for narrative instructions

- 1 graphic (cutaway) at \$1000
- Total Cost = \$720 + \$1000 = \$1720 (~ \$1800)

Deductive system descriptions and schematic/cutaway

- Maximum of 4 pages of narrative at \$200/page = \$800
- 1 graphic (cutaway) @ \$1000/page
- Total Cost = \$800 (narrative) + \$1000 (graphic) = \$1800

The difference in cost between the fully proceduralized and the alternative approaches is appreciable. Therefore, the system conditions discussed below should be reviewed to (1) verify that one of the less expensive approaches is satisfactory, or (2) justify the use of the more expensive approach.

**5.5 Task #3. Consider System Condition Indicators**

Seven system conditions are to be considered in selecting the format to support remove and replace actions. The influence which these system conditions exert on format selection is summarized in Table 4 and discussed below.

**Readiness Impact.** The type of information format to support remove and replace action is influenced by whether the system is "down" during the conduct of the maintenance action. The guidance for considering this condition is . . .

Consider a proceduralized format when the operational system is out of commission during the performance of the action. A deductive format is indicated when there is no immediate impact on readiness.

**Maintenance Demands.** A maintenance organization can receive its unscheduled workload in either of two ways: (1) batch source, where many maintenance actions can and usually do arrive in a short period of time (e.g., recovery of a flight of aircraft on board a CVA), or (2) single event source, where corrective maintenance needs are usually the result of a single system failure. The guidance for considering this condition is . . .

A batch source workload tends to require the proceduralized format whereas the single input source allows the deductive format.

**Job Scope.** The scope of a maintenance job may be quite broad, requiring the incumbent to be proficient on a wide variety of maintenance actions, possibly over two or more systems. Conversely, an incumbent's job scope may be quite narrow, involving frequent performance of a relatively small number of actions. The guidance for considering this condition is . . .

The broader the scope of the job, the more urgent the need for the proceduralized format.

**GCT Level.** The deductive formats for supporting remove and replace actions require "inferential reading" wherein the technician must understand narrative and/or related graphics in order to infer or deduce an action sequence. This is a difficult and time consuming performance, especially for poor readers. Therefore, in considering the GCT condition . . .

Use proceduralized formats for presenting remove and replace information when the GCT scores for the relevant Ratings are in the lower ranges.

**Span of Supervision.** The deductive format for presenting remove and replace information may be used effectively in spite of its complexity if the span of supervision approaches unity. The rationale is that, if necessary, the supervisor will have time to assist the junior technicians in interpreting the deductive aid. Therefore, the guidance for considering this condition is . . .

Consider the proceduralized format when the span of supervision is expected to be large, viz., greater than 1 supervisor to 10 technicians.

**Personnel Turnover.** Timely maintenance performance requires that the technicians know or be able to obtain certain job information (e.g., equipment recognition, tool usage, safety precautions, etc.). Typically, deductive formats do not contain this information requiring that it must come from training, either formal (C School) or OJT. This training takes time (reducing on-station time) and costs money. Neither the time nor the cost is justified where personnel turnover is

Table 4  
Summary of System Conditions Affecting Format for Presenting  
Remove and Replace Information

Condition	State/Format Indications	
	Proceduralized	Deductive
Readiness Impact	Down or degraded	No effect
Maintenance Demands	Batch	Single Event
Job Scope	Broad	Narrow
General Classification Test (GCT)	Low	High
Span of Supervision	High > 10	Low < 3
Personnel Turnover	High	Low
Distribution	Dispersed	Consolidated

high. Therefore, the guidance for considering this condition is . . .

Use the proceduralized format (which minimizes training) when the personnel turnover is expected to be relatively high, viz., *more than 50% of the crew will be replaced during a calendar year.*

**Equipment Distribution.** Merely locating equipment to be worked on is often a *time-consuming part of the* remove and replace actions. This tends to be especially true in cases where the hardware is spread over a considerable area as opposed to being consolidated in a single location. Therefore, the guidance for considering this condition is . . .

Consider the proceduralized format where the hardware is spread or dispersed (as in a ship's electrical system).

When the hardware is dispersed, the medium (or portrayal mode) selection is affected as well. The factors related to selection of portrayal mode are covered in Section 6.0.

#### 5.6 Task #4. Make Final Format Selection

Cost and system conditions are the basis for selecting a presentation approach, that is, a deductive or proceduralized approach. The extent of agreement between the system conditions indicates the specific format within an approach. This is a judgment based on the

number of conditions favoring a particular format. The example below illustrates this procedure.

#### *Example of Applying System Condition Indicators.*

The circled entries of Table 5 represent hypothetical conditions for remove and replace actions associated with the piece parts of the Steam Flow Transmitter, a component used in the earlier cost discussions. Four of the seven conditions favor the proceduralized approach. If all seven conditions favored the proceduralized approach, the \$14,000 fully proceduralized format might be justified. In fact, three of the conditions argue for use of the deductive approach.

Thus, the states of the system conditions circled in Table 5 suggest the following dispositions for each format candidate.

- Fully Proceduralized – Condition indications are not strong enough to warrant the substantial expense of this format.
- Deductive Format – Condition states indicate this format as a possibility but its performance-fostering power is suspect and its cost has no advantage over its partially proceduralized competitor.
- Partially Proceduralized – The cost of this format is comparable to its deductive competitor and the performance quality it produces is superior. These two points make it the logical choice.

**Table 5**  
**Example of Applying System Condition**  
**Indicators to the Problem of Selecting a Format for Presenting**  
**Remove and Replace Information**

Conditions	State/Format Indications	
	Proceduralized	Deductive
Readiness Impact	Down or degraded	No effect
Maintenance Demands	Batch	Single Event
Job Scope	Broad	Narrow
General Classification Test (GCT)	Low	High
Span of Supervision	High > 10	Low < 3
Personnel Turnover	High	Low
Distribution	Dispersed	Consolidated

## 6.0 ESTABLISH TM SUPPORT REQUIREMENTS

### 6.1 Introduction

The performance aiding potential of a format will be diminished considerably if the Technical Manual's (TM's) support requirements are not met. To meet these support requirements a TM must have features which: (1) make its content easy to find; (2) make the TM easy to store, distribute and update; and (3) make its content legible over extended uses or in adverse environments. TM features related to these requirements are termed access, recording mode, and display mode, respectively.

The access requirement addresses those TM characteristics designed to help the technicians find the information they need to perform maintenance actions. It concerns the listing of contents, indexing, internal

referencing and, in general, the organization of the TM. *Recording mode* concerns the means to store the maintenance information (with paper or microfilm being the most popular means available at present). *Display or Portrayal mode* refers to the means used to present the information to the user. Laminated coatings, pocket-sized books, and self-illuminated viewers are a few of the many variations which should be considered in choosing display mode for a system.

Certain maintenance-relevant conditions provide the basis for selecting the means to meet a system's support requirements. Table 6 relates these system conditions to the support requirements discussed above. The discussions in this section are organized about these three support requirements.

Table 6  
System Conditions Affecting Support Requirements

System Conditions	Support Requirements		
	Access	Recording Mode	Portrayal Mode
Automated Test Equipment	X		
Status Displays	X		
System Size		X	
Distribution		X	
Replication		X	
Installation Context		X	
General Classification Test			X
Illumination			X
Cleanliness			X
Space			X
Elements			X

## 6.2 Task #1. Determine Access Requirements

Difficulty in locating information causes much of the technician's frustration with conventional TMs. For example, research shows that with conventional tables of contents and indexes, technicians spend five percent of their job time unsuccessfully seeking TM information. They then spend *an additional twelve percent* of their job time obtaining guidance from other workers and supervisors. Thus, under the worst circumstances, almost one-fifth of the maintenance time is used in seeking job guidance. In too many cases, poor access forces the technician to rely on fallible, non-TM sources for job guidance.

Resolving this issue involves application of access techniques which apply to *all* systems as well as the selected use of techniques which apply only in certain circumstances related to Automated Test Equipment and Displays.

### General Recommendations

Certain access techniques are universal and should be used in all TMs. These are discussed below.

**Work Package.** A work packaging approach segments a system into a number of "mini" systems, each of which can have its own mini-manual or work package. Initial access is thus simplified by an alphabetical listing of work packages, rather than an excessively detailed table of contents.

A "local" table of contents provides within-package access to maintenance information, e.g., troubleshooting, parts listings, system description. The means for both initial and within-package access are illustrated in Figures 21 and 22.

**Periodicity Schedules.** Most equipment requires regular checks and inspections. The periodicity scheme illustrated in Figure 23 is an appropriate means of accessing job instructions for periodic maintenance.

**Symptom Indexing.** Troubleshooting or repair instructions are needed as a direct result of system malfunction indicated by the presence of *abnormal* symptoms. Symptoms can be uncovered during *regular* checks or during operation. Regardless of their source they occur either in the form of Automated Test Readouts and Status Displays (see below) or symptoms not displayed formally. The lack of displays or ATE readouts requires that the symptoms be couched in other observable terms, e.g., sounds, movements, timing, occurrence or non-occurrence of events. Figure 24 presents an illustrative listing of symptoms suitable for meeting this access need.

**Internal Access.** Internal access refers to the need for "follow-on" maintenance, e.g., a preventive action may uncover the need for troubleshooting; troubleshooting should indicate the need for repairs. Internal reference should be provided in an overview format (Figure 25) or a "refer to" format (Figure 26).

### System-Specific Access Needs

The system conditions of Status Displays and Automated Test indicate the need for two additional access techniques. These are discussed below.

**Status Displays.** Status displays are present most frequently in electronic/electrical equipment although hydraulic, pneumatic and other flow systems possess the trait to a lesser degree. When displays are present, a listing of Status Displays is appropriate to access troubleshooting aids. When numerous displays are present, it may be advisable to consider a decision logic table as opposed to a list, since *patterns* of display readings are more useful points of departure for troubleshooting. Both the listing and decision logic formats are illustrated in Figures 27 and 28.

**Automated Test Equipment (ATE).** This condition occurs most frequently in electrical/electronic equipment. When present, a listing of ATE outcomes is required to access troubleshooting (or possibly repair) instructions. Figure 29 illustrates a format which keys ATE readouts to the appropriate job aids.

ALPHABETICAL INDEX

NOTE

Work packages (WP's) listed in the index below contain all maintenance instructions (Removal, Installation, Testing, Troubleshooting, Adjustments, etc.) necessary to repair the subject component/system.

Subject	Work Package Retrieval Number	Section Number	Auto Code
A			
Air Conditioning Control Panel	03400	3	66
AMCS Coolant Fluid Expansion Tank	11100	9	*
AMCS Coolant Pump	11000	9	*
AMCS 82°F Coolant Sensors	11900	9	*
AMCS/Missile Air-Moisture Contaminate Removers	11700	9	*
AMCS/Missile Bypass Valves	11600	9	*
AMCS/Missile Cold Air Modulating Valves	10700	9	*
AMCS/Missile Controller	11800	9	*
AMCS/Missile Coolant 70°F Sensor	12300	9	*
AMCS/Missile Coolant 40°F Switches	12200	9	*
AMCS/Missile Cooling System	10600	9	*

\*Denotes Not Available

Figure 21. Indexing Sample for Accessing Work Packages

## Azimuth Mark Generator

	<u>Page</u>
Terminology Pictorial . . . . .	
Topdown Breakdown . . . . .	
Operating Description	
Function . . . . .	
Two-Stage Amplifier . . . . .	
Emitter Follower . . . . .	
Trouble Analysis Aids	
Verification of Malfunction . . . . .	
Power Checks . . . . .	
Piece Part Isolation Checks . . . . .	
References	
Repair . . . . .	
Adjust/Alignment . . . . .	
Standard Operating Procedures (SOP) . . . . .	

Figure 22. Local Table of Contents for a Work Package

<u>Interval/Requirement</u>	<u>MRC #</u>
<b>Condition Checks</b>	
Hot Start . . . . .	114.1 - 114.4
Hard Landing . . . . .	62.0 - 70.6
100 Arrested Landings . . . . .	
etc.	
Preflight . . . . .	
Postflight . . . . .	
<b>Interval Checks</b>	
Daily . . . . .	200.0 - 210.0
14 days . . . . .	800.0 - 820.0
28 days . . . . .	

Figure 23. Sample of Periodicity Index for Scheduled Inspections

SYMPTOM INDEX

	<u>Troubleshooting Procedure</u>
<b>COOLING SYSTEM</b>	
Radiator	
Boils over . . . . .	3-12
Leaks . . . . .	3-17
Temperature Gage	
No indication . . . . .	3-29
Runs cold . . . . .	3-11
Runs hot . . . . .	3-13
<b>ENGINE</b>	
Misses . . . . .	3-34
Overheats . . . . .	3-72
Won't start . . . . .	3-27
<b>EXHAUST SYSTEM</b>	
Excessive smoke . . . . .	3-33
Water vapor . . . . .	3-33

Figure 24. Sample Format for Indexing for Mechanical Equipment

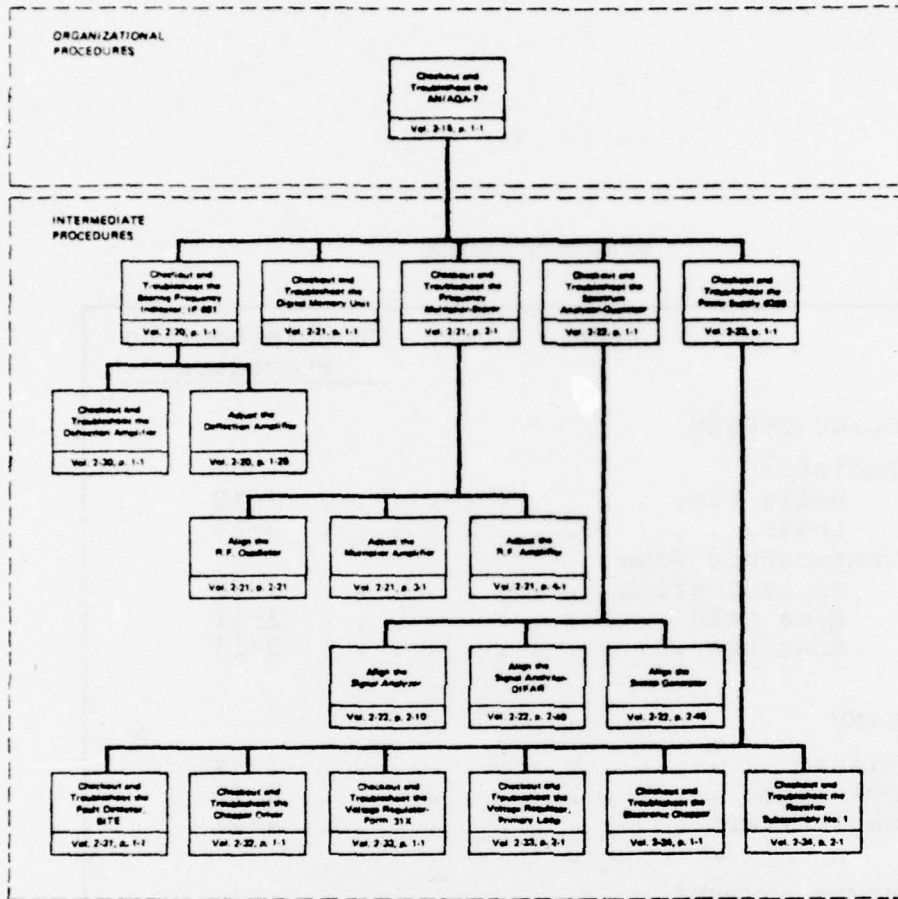

Figure 25. Sample of Overview Format for Follow-on Maintenance

**NOTE**

Follow-on Maintenance Action Required:  
 "Install Main Driveshaft" (Vol. 12, p. 4-1)

Figure 26. Sample of "Refer to" Format for Follow-on Maintenance

Engine and Transmission  
Instruments Located on Pilot's  
and Copilot's Instrument Panel

JPA UH-1H-2TS-	Page
Indicators	*
AC Volt- meter (9)	4, 4-1 22, 1-1
Standby Gener- ator Load- meter (10)	4, 3-1 19, 1-1
Main Generator Loadmeter (11)	4, 3-1 19, 1-1
Transmission Oil Pressure (1)	2, 2-1 6, 2-1
Engine Oil Pressure (2)	3, 6-1 13, 3-1
Fuel Pressure (3)	3, 2-1 16, 3-1
Fuel Quantity (4)	3, 2-1 16, 1-1
Engine Oil Temperature (5)	3, 6-1 13, 3-1
Transmission Oil Temperature (6)	2, 2-1 6, 2-1
Dual Tachometer (7)	3, 5-1 13, 2-1
Torquemeter (8)	3, 6-1 13, 3-1

\*Refer to callout number on accompanying illustration.

Figure 27. Access to Troubleshooting Aids Via Status Indicators

Display Readout

Symptom Patterns

PWR SUPPLY OK	N	N	N	N	N	N	N	N	Y	Y	Y	Y	Y	Y	Y	Y
MASTER CLOCK OK	N	N	N	N	Y	Y	Y	Y	N	N	N	N	Y	Y	Y	Y
TRANSMITTER OK	N	N	Y	Y	N	N	Y	Y	N	N	Y	Y	N	N	Y	Y
RECEIVER OK	N	Y	N	Y	N	Y	N	Y	N	Y	N	Y	N	Y	N	Y
ENTIRE SYSTEM BAD;	X															
GO TO INTERFACE																
DO PWR SUPPLY CK		X	X	X	X	X	X	X								
DO MASTER CLOCK CK		X	X	X					X	X	X	X				
DO TRANSMITTER CK		X			X	X			X	X			X	X		
DO RECEIVER CK			X		X		X		X		X		X		X	
ENTIRE SYS OK																X

Indexed Aids

Figure 28. Sample of a Decision Logic Table Format for Using Status Displays to Index Aids

BIT TEST	FIGURE
001	7-1
004	7-2
005	7-2
006	7-2
007	7-2
008	7-2
009	7-2
010	7-2
011	7-2
012	7-2
012.10	7-3
013	7-3
014	7-4
015	7-5
016	7-6
017	7-7
018	7-7
019	7-7
020	7-8
021	7-9
022	7-9

BIT TEST	FIGURE
023	7-9
026	7-9
029	7-9
031	7-9
032	7-10
033	7-10
034	7-10
035	7-10
036	7-11
037	7-11
038	7-11
039	7-11
042	7-11
043	7-11
044	7-11
045	7-11
050	7-11
051	7-11
054	7-11
055	7-11

Figure 29. Access to Troubleshooting Aids Via Built-in Tests, Sample Format

### 6.3 Task #2.

#### Determine Recording Medium Requirements

Virtually all surveys of TM problems note the presence of "untimely deliveries," "out of date information" and "inadequate storage space." These complaints are attributable largely to the bulk of the paper medium. The microform medium has been shown to reduce the severity of these problems and is being used for many systems. However, microform viewers and printers do not enjoy high user acceptance. In addition, their usefulness is debatable for small systems where the distribution, storage, and update problems are not especially severe.

The conditions of (1) Size, (2) Distribution, (3) Replication, and (4) Installation context, are used to indicate the best recording medium for a system. The following discussions summarize the recording modes suggested by various states of these conditions.

#### System Size

The size of the information base is related directly to the severity of TM distribution, storage space, and update problems. Since microform can reduce the severity of these problems in a large system, it is the recommended recording mode.

The exact system size at which paper should be abandoned in favor of microform is not established. The following rules of thumb are offered to help establish a recording mode threshold.

- Use paper for information bases up to 300 frames and,
- Use microform mode for information bases beyond 1,500 frames.

In the middle range, the additional system conditions discussed below are to be used in deciding recording mode.

#### Distribution

Job information must be available to the user at his work site. This need is related to recording mode when there is a large system (indicating use of microform mode) distributed over a large area (indicating the need for information portability). The media options to consider for such a large, dispersed system are, (1) por-

table microform viewers and/or (2) centralized microform with printer. Figures 30 and 31 show typical mechanizations of these recommendations.

A large system with a consolidated layout permits the use of a centralized microform reader without printer. However, a consolidated layout frequently involves such small system size that a paper recording mode is practical.

#### Replication

The number of systems to be installed in the Fleet influences the selection of a recording mode. When a large number of systems is installed, distribution problems occur which microform tends to counter. On the other hand, the distribution of new TMs and changes is not a severe problem when the Fleet has only one or a few systems.

Therefore, system size and replication exert reinforcing influences on the recording mode; that is, a system with many replications tends to warrant the microform recording mode while a system with a few replications tends to permit the paper or book mode.

#### Installation Context

Most equipment tends to operate in a multi-system context, such as in a shipboard installation. In these situations, "adjoining" systems may share the cost and capacity of a microform recording mode, thereby translating two or more small systems into the equivalent of a large system. When a small or mid-range system operates independently of other systems, a paper recording mode is to be considered.

### 6.4 Task #3. Determine Portrayal Mode Requirements

Present TM practices tend to use one TM medium (viz., microfiche, microfilm, or paper) to meet the needs of all systems. This standardized approach results in preparation economies but it also causes mismatches between workplace conditions and TMs. These mismatches could well be a cause of poor TM utilization, a consequence which diminishes any production economies. Thus, a single medium may not be equally suitable for all system TMs or even for all TM applications within a system. To preclude potential problems, the following workplace conditions should be used to

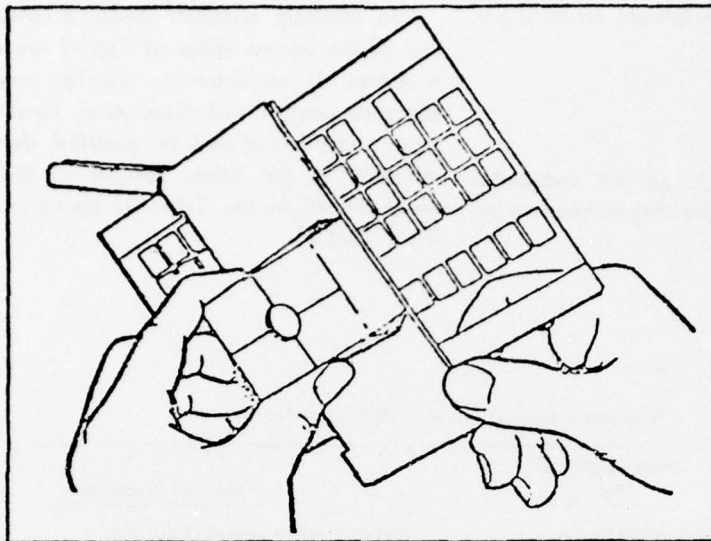

Figure 30. Sample Microform Recording Medium

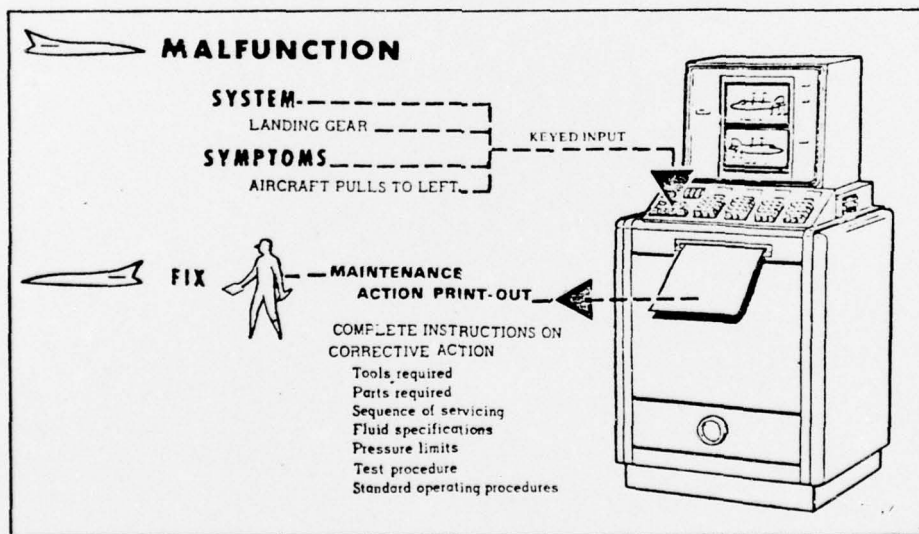

Figure 31. Example of Microform Recording Medium with Printout Capability

challenge the recording mode selections made in previous steps.

- Illumination
- Workspace
- Cleanliness
- Elements (Wind, Rain)

Table 7 displays the good and the undesirable portrayal mode possibilities for meeting adverse versions of these conditions.

To challenge candidate media, determine whether any of the adverse states of Table 7 are expected in a system. If so, determine whether previous media selections conflict with these states. Candidates which present conflicts should be modified along the lines indicated in the Table. Samples of the acceptable media named in the Table are shown in Figures 30, 32, 33 and 34.

Table 7  
Workspace Conditions and Matching Media

<u>Adverse Condition</u>	<u>Poor Candidate Media</u>	<u>Solution Possibilities</u>
Dark workspace . . . . .	No integral light source . . . . .	Self-illuminated viewers (Figure 34)
Glare . . . . .	Unprotected viewers . . . . .	Hoods (Figure 32), matte paper
Wind or rain . . . . .	Plain paper . . . . .	Laminated coating
Dirt . . . . .	Plain paper . . . . .	Laminated coatings
Cramped workspace . . . . .	Large books or viewers . . . . .	Miniature viewers, pocket size books (Figures 30 and 33)

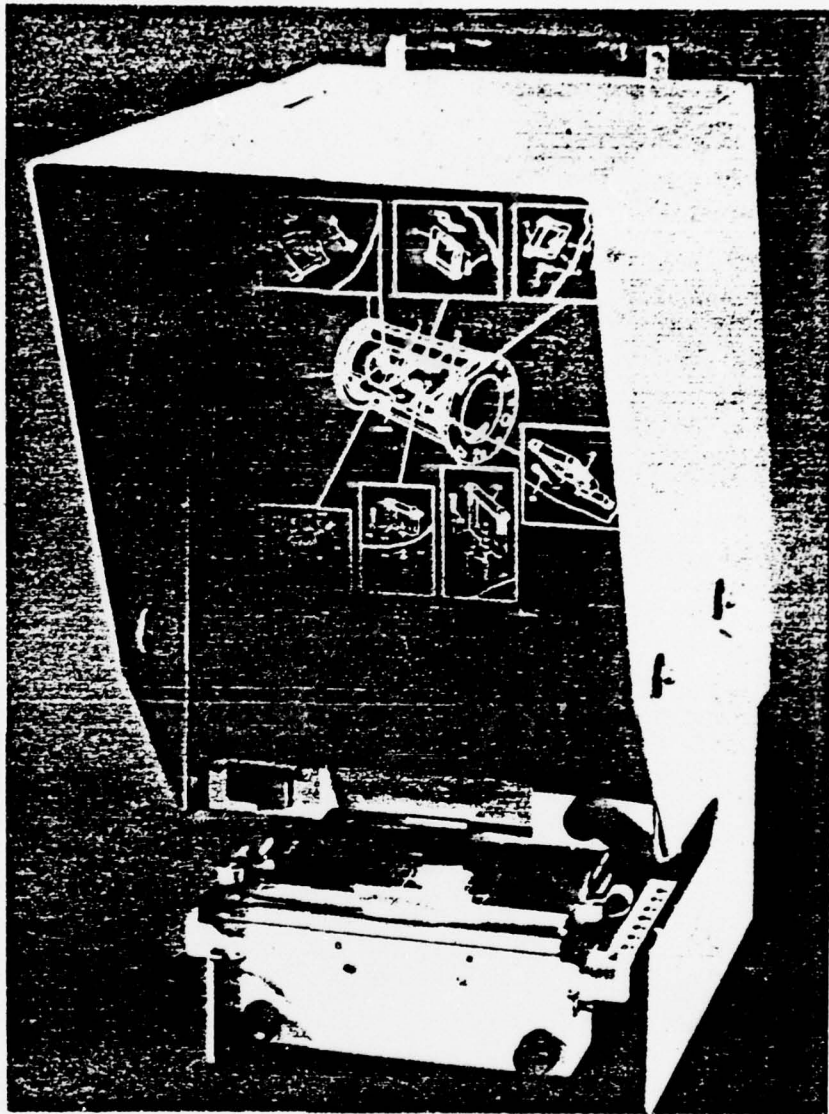

Figure 32. Hooded Viewer

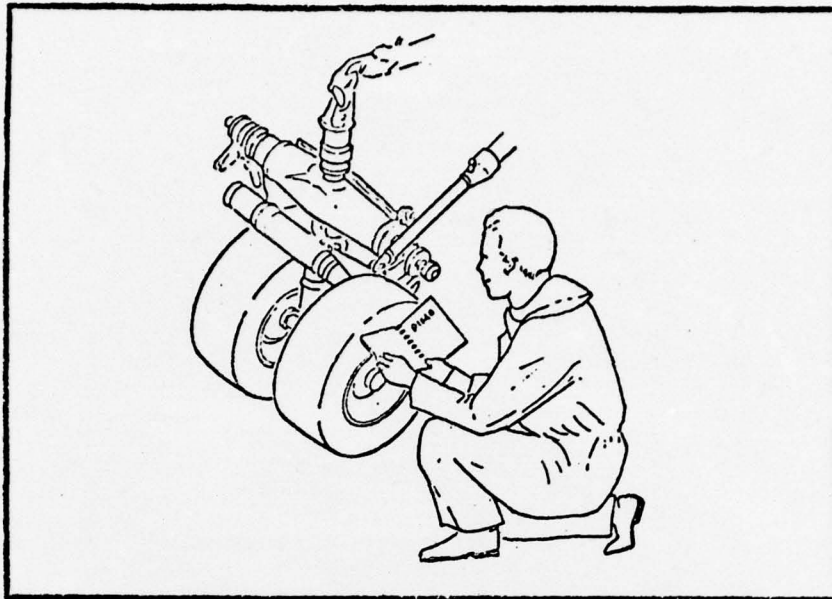

Figure 33. Representative Portable Booklet Aids

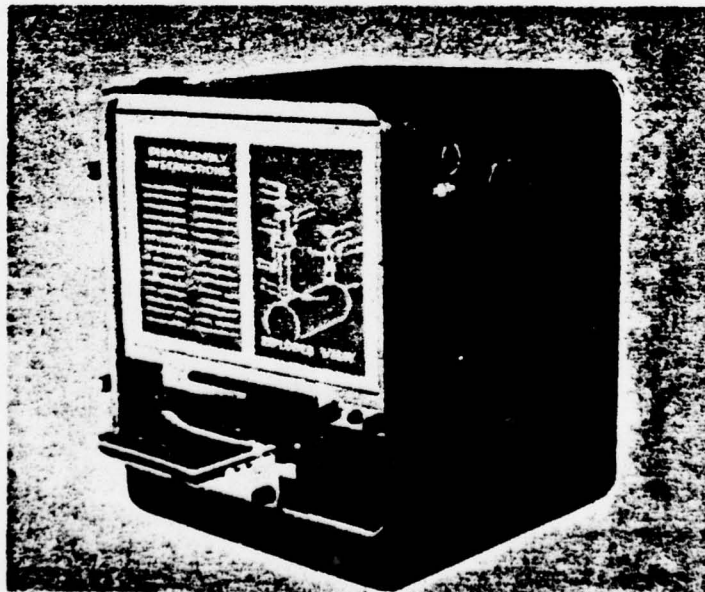

Figure 34. Self Illuminated Viewer.

## REFERENCES

- Letterkenny Army Depot, U.S. Army Materiel Command. Equipment manuals, maintenance data techniques. WSMAC. Technical report. February 1972.
- Post, T.J. & Price, H.E. Development of optimum performance aids for troubleshooting. Prepared by BioTechnology, Inc. for Naval Air Systems Command, Washington, D.C. April 1973.

INITIAL DISTRIBUTION

Copies	Copies
1 OASD (I&L)/Mr. R. Shorey	3 CNET (N50)/Dr. W. Scanland (N521)/Mr. Bob Jones (N54)/Mr. John H. Pinning
2 DLSIE	
1 ODDR&E/COL. Henry L. Taylor	1 CNETS (3314)/Mr. J. Barron
1 AMC(MA-SM4)/ Mr. R. Graves	
2 ARI Dr. Otto Kahn Dr. Joseph Ward	3 CNTT (0101)/Dr. N. Kerr (0162)/Mr. E. M. Evans (N331)/Mr. A. P. Zaluski
1 ARMY HEL(AMXHE HEL) Mr. D. S. Mackey	3 NTEC (N210)/Dr. J. Duva (N215)/Dr. William King (N423)/Mr. Ralph Laugen
2 AMXMD-EP Mr. Roy Post Mr. Art Rulon	
6 CNO (OP-09B1) (OP-355) (OP-401G)/Mr. B. Gruber (OP-987)/Dr. R. Smith (OP-991B)/Mr. M. Malehorn (OP-991C)/Mr. D. Thurman	3 NAVMAT (0344)/Mr. I. Rubinstein (04)/ Mr. J. Genovese (0422)/Mr. W. O'Hern
3 CINCLANTFLT Code NFM3 Code 04 Code 047	2 BUPERS (PERS 212D)/LCDR L.W. Beguin
1 CINCPACFLT/Code 431	1 ONR (45B)/Dr. M. Farr
4 COMNAVSURFLANT Code N42 Code N44 Code 64 READSUPGRU	1 NALEXENGGEN SDIEGO/Mr. M. Gordon
1 COMNAVSURFPAC/Code 40	2 NAVSUP (0431C)/Mr. G. Bernstein (10)/Mr. H. Burby
1 COMNAVAIRLANT/Code 731	8 NAVSEA (OOG)/Mr. H. Hill (0463)/Mr. W. G. Shihda (660F)/Mr. D. Baird (660F)/Mr. J. Jenkins (6181C)/Mr. S. Myers (PMS 301)/CAPT Parker (PMS 403-15)/Mr. T. W. Taylor (PMS 306)
1 COMOPTEVFOR/CDR Donovan Code 32	1 NAVSEACEN SDIEGO

INITIAL DISTRIBUTION (continued)

Copies

9 NAVAIR  
 (04A4)/Mr. H. Keneman  
 (04A4)/Mr. W. G. Muller  
 5 (340C)/Mr. D.S. Hurst  
 2 (340F)/LCDR P. Chatelier

5 NPRDC  
 Dr. J. Regan  
 Dr. E. Akin  
 Dr. G. Ramas  
 Dr. T. Curran  
 Dr. R. Blanchard

3 TAEG(NOOT)/Dr. R. Braby

1 NSWSES (5001)/Mr. C. Root

2 NSDSA (5700)/Mr. K. Radcliff

3 NTC, San Diego  
 CAPT C. McDaniel  
 Mr. D. Lovell  
 (PQSDG)/CDR Peterson

1 NTC, Great Lakes  
 CAPT O'Malia

1 Navy Occupation Development and  
 Analysis Center (NODAC)  
 CAPT E. M. Anderson, C.O.

12 Defense Documentation Center

1 USAF (LGYE)/Mr. R. Welsh

1 USAF (DAYX HDQ)/Dr. Ron Burkett

1 USAF (DAYX HDQ)/Mr. V. Kehler

2 AFHRL (WPAFB)  
 Mr. J. Klesch  
 Mr. R. Johnson

3 HQ, AFLC (WPAFB)  
 (ASD/SMA)/COL. J. Ostrominski  
 (LOLMP)/Mr. M. DeLisio  
 (PRAM)/Mr. W. Wisner

Copies

1 University of Ohio/Dr. G. Klare

1 University of MD/Dr. T. Powers

5 Hughes Aircraft Company  
 ATTN: Mr. J. Connell, M-308  
 Ground Systems Group  
 P. O. Box 3310  
 Fullerton, California 92634

1 Mr. Ben Saltzer  
 1802 Massachusetts Avenue  
 Cambridge, Massachusetts 02140

1 BioTechnology, Inc.  
 ATTN: Mr. T. Post  
 3027 Rosemary Lane  
 Falls Church, Virginia 22042

1 ManTech of New Jersey  
 ATTN: Mr. R. Royston  
 6110 Executive Blvd.  
 Rockville, Maryland 20852

1 Stanford Research Institute  
 ATTN: Mr. J. Bialik  
 333 Ravenswood Avenue  
 Menlo Park, California 94025

1 Telecom Systems, Inc.  
 ATTN: Mr. Skewis  
 2300 South 9th Street  
 Arlington, Virginia 22204

5 Westinghouse Corp.  
 ATTN: Mr. J. Box  
 3709 Pepper Road  
 Hunt Valley, Maryland 21030

CENTER DISTRIBUTION (continued)

Copies	Code	Copies	Code
1	18	1	1808
1	1809.1	1	184
1	1809.3	1	186
1	183	2	1861
1	185	1	1864
30	186A	1	1867
1	1863	1	188
1	1865	1	2784
1	5211		