

AD-A033 998

FRANKFORD ARSENAL PHILADELPHIA PA
EXECUTIVE SUMMARY FOR THE PRELIMINARY DESIGN STUDY OF A DIGITAL--ETC(U)
AUG 76 R S SEGAL

F/G 15/3

UNCLASSIFIED

FA-TR-76048

NL

1 OF 1
AD-A
033 998



END
DATE
FILMED
2-17-77
NTIS

U.S. DEPARTMENT OF COMMERCE
National Technical Information Service

AD-A033 998

EXECUTIVE SUMMARY FOR THE PRELIMINARY DESIGN STUDY
OF A DIGITALLY STABILIZED AND CONTROLLED BRASSBOARD
DIRECTOR TYPE FIRE CONTROL SYSTEM FOR THE PRODUCT
IMPROVED VULCAN (II VADS)

FRANKFORD ARSENAL
PHILADELPHIA, PENNSYLVANIA

AUGUST 1976

010030

AD

ADA033998

FA-TR-76048

EXECUTIVE SUMMARY FOR THE PRELIMINARY DESIGN STUDY
OF A DIGITALLY STABILIZED AND CONTROLLED BRASSBOARD
DIRECTOR TYPE FIRE CONTROL SYSTEM FOR THE PRODUCT
IMPROVED VULCAN (II VADS)

by

Robert S. Segal

August 1976

DDC
RECEIVED
JAN 6 1977
C

Approved for public release; distribution unlimited.

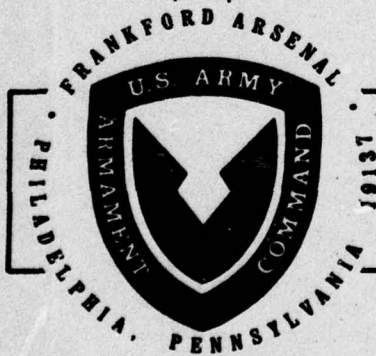

Fire Control Development and Engineering Directorate

U.S. ARMY ARMAMENT COMMAND
FRANKFORD ARSENAL
PHILADELPHIA, PENNSYLVANIA 19137

REPRODUCED BY
**NATIONAL TECHNICAL
INFORMATION SERVICE**
U. S. DEPARTMENT OF COMMERCE
SPRINGFIELD, VA. 22161

UNCLASSIFIED

SECURITY CLASSIFICATION OF THIS PAGE (When Data Entered)

REPORT DOCUMENTATION PAGE		READ INSTRUCTIONS BEFORE COMPLETING FORM
1. REPORT NUMBER FA-TR-76048	2. GOVT ACCESSION NO.	3. RECIPIENT'S CATALOG NUMBER
4. TITLE (and Subtitle) EXECUTIVE SUMMARY FOR THE PRELIMINARY DESIGN STUDY OF A DIGITALLY STABILIZED & CONTROLLED BRASSBOARD DIRECTOR TYPE FIRE CONTROL SYSTEM FOR THE PRODUCT IMPROVED VULCAN (II VADS).		5. TYPE OF REPORT & PERIOD COVERED Final Engineering Report
7. AUTHOR(s) ROBERT S. SEGAL		6. PERFORMING ORG. REPORT NUMBER
9. PERFORMING ORGANIZATION NAME AND ADDRESS FRANKFORD ARSENAL Attn: FCW-D Philadelphia, PA 19137		8. CONTRACT OR GRANT NUMBER(s)
11. CONTROLLING OFFICE NAME AND ADDRESS US Army Armament Command Rock Island Arsenal Rock Island, IL 61201		10. PROGRAM ELEMENT, PROJECT, TASK AREA & WORK UNIT NUMBERS AMCMS: 233732.12.12600 DA PROJECT: 1W323732D182
14. MONITORING AGENCY NAME & ADDRESS (if different from Controlling Office)		12. REPORT DATE August 1976
		13. NUMBER OF PAGES 41
		15. SECURITY CLASS. (of this report) UNCLASSIFIED
		15a. DECLASSIFICATION/DOWNGRADING SCHEDULE N/A
16. DISTRIBUTION STATEMENT (of this Report) Approved for public release; distribution unlimited.		
17. DISTRIBUTION STATEMENT (of the abstract entered in Block 20, if different from Report)		
18. SUPPLEMENTARY NOTES The project engineer is greatly indebted to the many members of his design team for contributing to the successful completion of this effort. In particular, thanks are due to Messrs. Dennis Delany, Gim Chin, Bob Volz, William Sperling, Al Barchi and Dr. Kenneth Fegley.		
19. KEY WORDS (Continue on reverse side if necessary and identify by block number) Fire Control Systems Gun Anti-Aircraft Stabilization and Control		
20. ABSTRACT (Continue on reverse side if necessary and identify by block number) This report summarizes a preliminary design study to increase Vulcan Air Defense System effectiveness, via an improved digital fire control system. The fire control system under study employed a non-gyro computer stabilized sight, range only radar, digital computer and digital shaft encoder/tachometer sensors on the weapon systems gun and turret gimbals.		

DD FORM 1 JAN 73 1473 EDITION OF 1 NOV 65 IS OBSOLETE

UNCLASSIFIED

SECURITY CLASSIFICATION OF THIS PAGE (When Data Entered)

TABLE OF CONTENTS

	<u>PAGE</u>
INTRODUCTION	3
DIRECTOR SYSTEM APPROACH	5
"DIRECTOR" SYSTEM MECHANIZATION.	5
COMPUTER STABILIZED AND CONTROLLED UNITY POWER DIRECTOR SIGHT.	12
GUN/TURRET SENSORS	10
FIRE CONTROL COMPUTER AND ITS MECHANIZATION.	16
MODIFIED VULCAN HAND CONTROL	21
SYSTEM INTERFACING	21
SUMMARY OF VULCAN HARDWARE ADDITIONS REQUIRED TO PROVIDE A DIRECTOR CAPABILITY	25
DIRECTOR SYSTEM ERROR BUDGET	25
DIRECTOR SYSTEM REACTION TIME.	25
PROGRAM COSTS.	25
GOVERNMENT COSTS	30
BRASSBOARD SCHEDULE.	32
CONCLUSIONS.	33
RECOMMENDATIONS.	36
REFERENCES	38
DISTRIBUTION	39

LIST OF TABLES

TABLE

1. Tentative Cabling List	24
-------------------------------------	----

TABLE OF CONTENTS (Cont)

List of Illustrations

<u>FIGURE</u>		<u>PAGE</u>
1.	Russian ZSU 23-4.	4
2.	Rate Servo Sight Director System (Gun Pointing Mode).	6
3.	Rate Servo Sight Director System (Acquisition Mode)	9
4.	Proposed Director Sight (Modified M61).	11
5.	Encoder Tachometer Package.	12
6.	Director Sight Optical Schematic.	13
7.	Mounting of Gun/Turret Sensors (Elevation View)	14
8.	Mounting of Gun/Turret Sensors (Plan View).	15
9.	Turret Sensor Package	17
10.	CDC 469 Envelope Sketch	18
11.	Vulcan Director System.	19
12.	Algorithm Flow Diagram.	20
13.	Present Vulcan Hand Control MOD Schematic	22
14.	Tentative Cabling Interconnection Diagram Director System	23
15.	Error Budget.	26
16.	Sequence of Events from Detection to Fire (Director System).	28
17.	Position Sensor Director System (Alternative 1)	34
18.	Position Sensor Stabilized Director Sight (Modified M61).	35
19.	Position Sensor Director System (Alternative 2)	37

INTRODUCTION

A Memorandum¹ for Acting Secretary of the Army (R&D) requested that an investigation be conducted to determine simple low cost Vulcan product improvement options capable of increasing mission effectiveness. A contract was finalized with Applied Physics Laboratory of John Hopkins University (APL/JHU) on 11 November 1975 to satisfy this requirement. Frankford Arsenal's Fire Control Laboratory prepared numerous product improvement documents to support the APL/JHU investigation. In addition, a copy of a proposal² to ARMCOM for conducting a preliminary brassboard design study of a computer stabilized director type fire control system for Vulcan was forwarded to APL. The approach outline in the proposal was to:

1. Develop a computer stabilized non-gyro director system concept.
2. Simulate this concept and determine its pointing accuracy and stability.
3. Conduct preliminary flow charting and programming analysis of candidate fire control algorithms.
4. Determine which digital mini-computer could be utilized to solve the fire control algorithms.
5. Develop the preliminary mechanical, electrical and optical drawings of a "brassboard" director type sight.
6. On paper, integrate the sight, computer, turret/gun servos and range only radar.
7. Report all findings together with those cost and schedules required to fabricate the brassboard director system.

The underlying design principles embodied in the system proposed for study were recognized throughout Europe³ and the United States for many years and were implemented in analog configurations such as the Russian ZSU 23-4. The ZSU 23-4 was entirely analog and consisted of both a radar and optically directed gun system (Figure 1).

¹Memorandum for Acting Assistant Secretary of the Army (R&D), SUBJECT: Vulcan, Norman R. Augustine, Under Secretary of the Army dtd 9 June 1975.

²Proposal for the Preliminary Design Study of a Director Type Fire Control System for the Vulcan Air Defense System (VADS) by Robert S. Segal, 1 March 1976.

³"Some Applications of Servomechanisms and Analog Computers in Anti-Aircraft Defense" by Mr. L. Ambrosini (at the time of writing), Chief Engineer at Hispano Suiza Corp., Geneva, Switzerland, not dated.

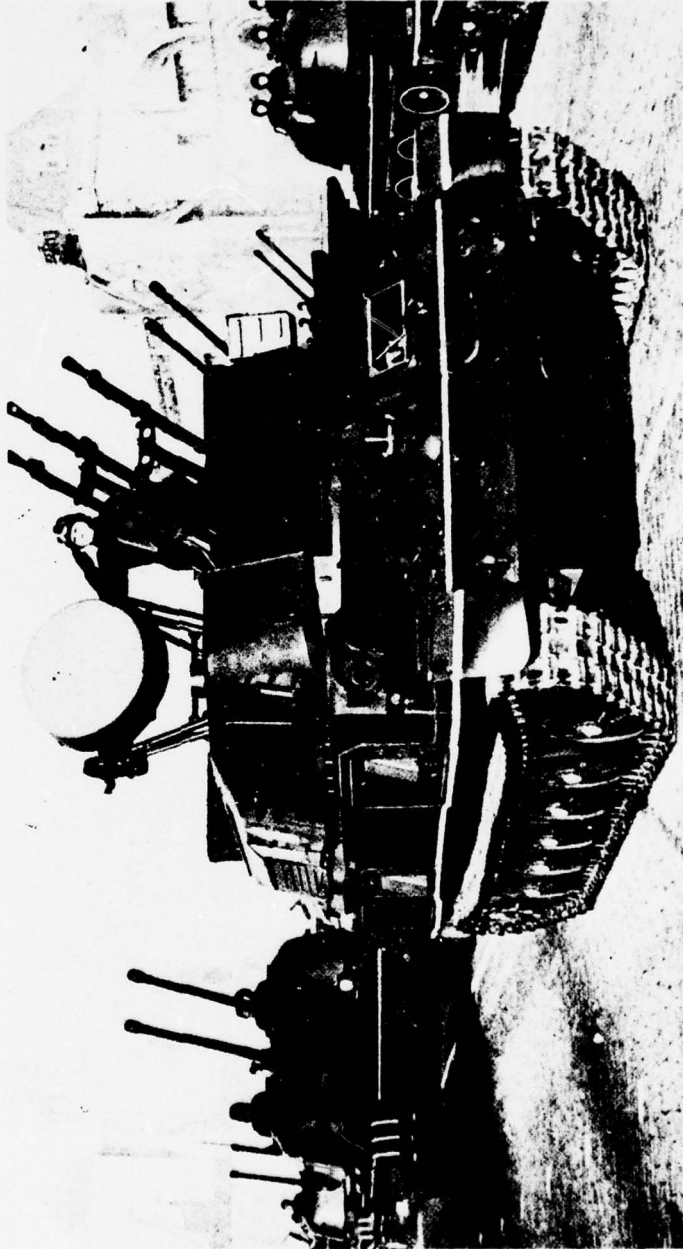
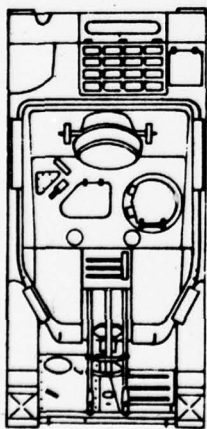
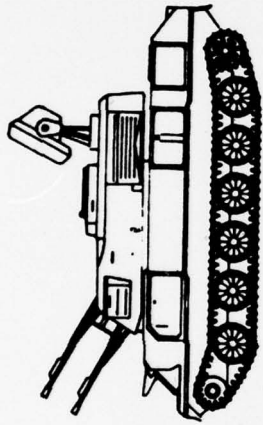
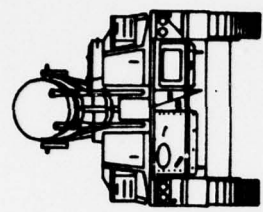

Figure 1. Russian ZSU 23-4

With the advent of digital techniques the opportunity to produce a low cost, flexible and accurate configuration was evident. Therefore, on 1 April 1976 approval to conduct the study was received and a team of fire control engineers began to investigate a digitally controlled, product improved Vulcan. An executive summary of their findings is presented herein.

DIRECTOR SYSTEM APPROACH

Major caliber anti-aircraft batteries employed during WW II and immediately thereafter utilized an off-carriage manual tracker and computer known as a "director". Since the tracker was completely disassociated from the weapon the operator's tracking performance was undisturbed by gun/mount motion, and therefore, the system designer could optimize tracker characteristics without concern for the gun/mount dynamics.

In a mobile weapon system such as the Vulcan an off-carriage tracker is impractical; however, it is possible to arrange the system so that "director" tracking performance is closely approximated i.e., gun/mount dynamics do not influence target acquisition time or tracking accuracy.

Two approaches to accomplish this have been considered. Utilizing gyros to reference the sightline to inertial space and thereby essentially decoupling all the gun/turret vehicle disturbances was examined in other projects.⁴ Another solution to the problem, and one which this report studies in detail, is a process wherein the sight is mechanically "unwound" with respect to the weapon, by employing a combination of digital tachometers, shaft encoders and synchros. With this arrangement unwanted line of sight motion due to gun dynamics is essentially eliminated and a digital approach to analog systems such as the ZSU 23-4 results.

"DIRECTOR" SYSTEM MECHANIZATION

Shown in Figure 2 is a schematic diagram of the non-gyro stabilized "director" sight approach which forms the basis of this design study. In order to simplify the understanding of how tachometers, synchros, etc. may be used to "mimic" inertial elements only the azimuth channel of the sight is shown on the diagram. The addition of the elevation channel would complicate the explanation by the introduction of mechanisms and mathematical processes required for the geometric transformation of angles and angular rates between coordinate systems. As these conversions are normally associated with systems in which the sight unit elevates with the weapon this inclusion would do nothing to further an explanation of the concept.

⁴Final report for AFAADS Advanced Component Development Stabilized Optical Tracker, Sperry Univac, Publication No. PX-8448, 15 April 1971.

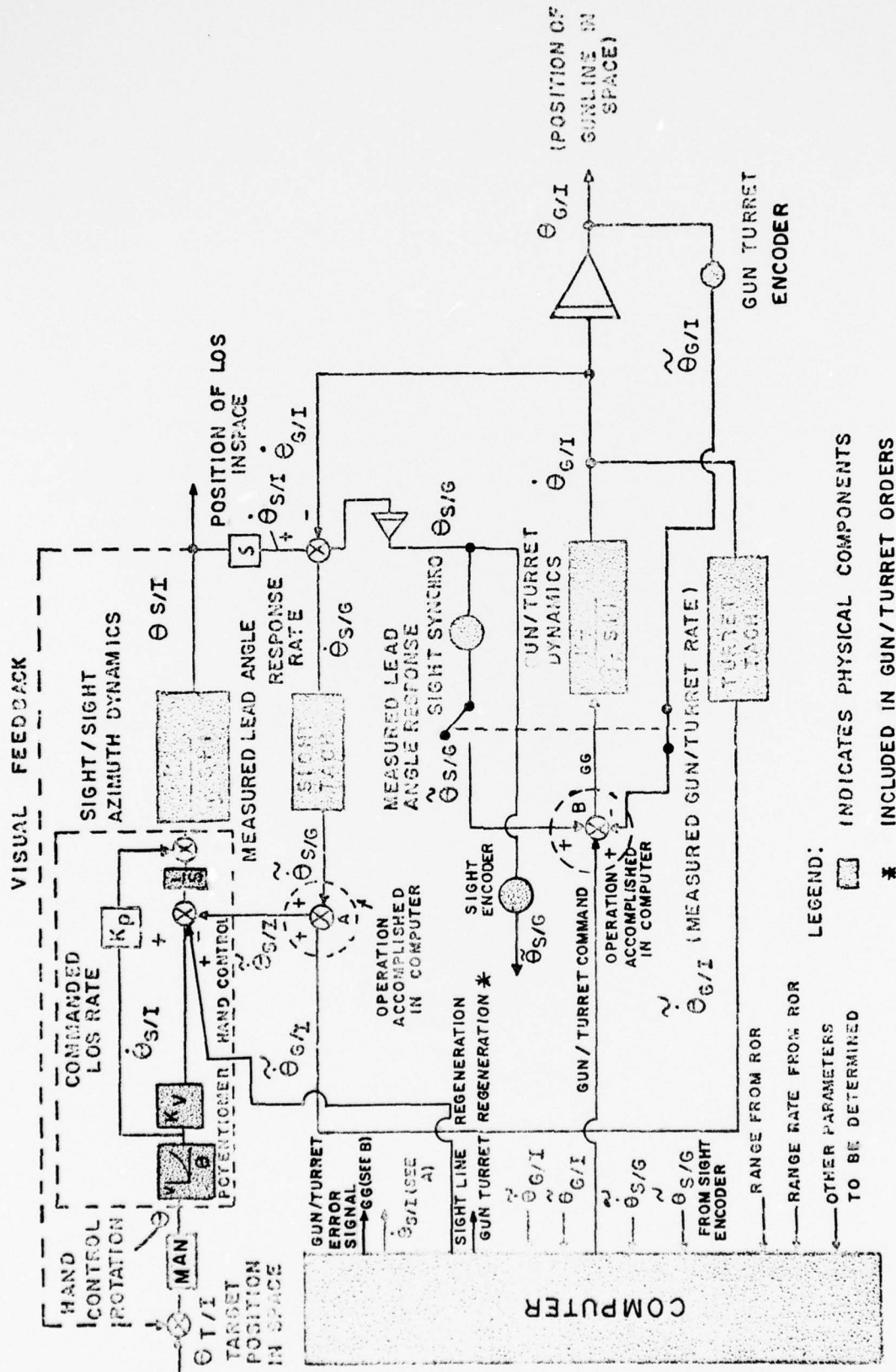

Figure 2. Rate Servo Sight Director System (Gun Pointing Mode)

The principle kinematic input to the system is the target's behavior (Figure 2). The target angular position ($\theta_{T/I}$) is the stimulus to the operator's control of the line of sight in space ($\theta_{S/I}$): The target range and range rate are measured by the existing range only radar and are provided to the systems computer for computation of gun pointing commands and tracking regeneration signals to aid the gunner. Systems outputs are:

1. Sightline position in space coincident with the target line.
2. A gun line properly oriented in space to maximize weapon effectiveness.

We will first consider the target/operator system interaction in so far as achieving desired sightline control.

As may be seen from the Figure 2 the angular rate of the sightline with respect to the gun, $\dot{\theta}_{S/G}$, is measured by a tachometer placed within the sight unit. If it is assumed that the weapon carrier hull is stationary the tachometer measuring turret rate, produces a signal equal to the angular rate of the gun in inertial space ($\dot{\theta}_{G/I}$).

As shown on the diagram the addition of $\dot{\theta}_{S/G}$ to $\dot{\theta}_{G/I}$ results in $\dot{\theta}_{S/I}$ which is the measurement of the sightline angular rate in space. This is, of course, identical to the quantity that would be measured by a gyroscope if one were employed in the system.

The gunner observing the target through the sight sees whether or not his tracking is correct. If it is not correct he moves his hand control which commands his sightline rate to increase or decrease as required. This commanded sight rate $\dot{\theta}_{S/I}$ is compared with the measured sight rate $\dot{\theta}_{S/I}$ that is produced by the addition described above. If these quantities are unequal an error signal is developed which drives the sight until a null is produced.

It should be noted on the diagram that in addition to commanding angular rate into the sighting system the tracking circuit provides a position component as well. If the gunner observes that he is lagging the target, he not only increases sightline rate but introduces a direct change in the position of the line of sight as well.

It can be demonstrated mathematically that this type of "aiding" reduces the oscillations of the line of sight in inertial space or in other words it provides for smoother tracking.

As may be seen from Figure 2 the sightline and gun angular rates $\ddot{\theta}_{S/G}$ $\ddot{\theta}_{G/I}$, along with several other quantities are utilized by the computer to generate "Gun/Turret Command" which is the desired position of the weapon in space including leads. In the "gun pointing" mode shown on the figure the weapon positioning servo operates to point the gun in the direction commanded.

Consider for example Figure 2 and the following situation in which both a zero sightline rate ($\dot{\theta}_{S/I}=0$) is commanded by not moving the hand control and a ramp in position is introduced in to the gun/turret servo drives. Let us examine the possibility of the resulting gun motion perturbing the line of sight from the position of rest. For the conditions, stated, a step in weapon rate ($\dot{\theta}_{G/I}$) is produced. This motion is measured simultaneously by the turret and sight tachometers considering other effects to be negligible. The signals ($\dot{\theta}_{S/G}$, $\dot{\theta}_{G/I}$) emanating from each sensor must by virtue of the stated conditions, be equal in magnitude and opposite direction. Since each signal is electronically opposed to one another (see summing junction), they combine to create a measure of the sight's response rate to the disturbance imposed by gun/turret dynamics, which for the sake of this discussion is zero ($\ddot{\theta}_{S/I}=0$). Hence the line of sight goes undisturbed, and is controlled solely by gunner command. In addition to the above it should be noted that the computer extrapolates sightline rate based on past history of the target.

Following the establishment of smooth target tracking this extrapolation which is known as regeneration would in principal permit tracking of the target without action on the part of the gunner. In actual practice, however, the gunner must correct for system errors and changes in target path. Nevertheless, the tracking load on the gunner is drastically reduced by such a feature.

Target acquisition will be carried out by slaving the gun line to the line of sight (Figure 3). This is accomplished by feeding the sight's synchros signals directly to the gun/turret servo amplifiers. Upon targets acquisition (radar lock-on accomplished) the system automatically switches to the gun pointing mode. It should be noted that the acquisition mode can be utilized in a point or area suppression role if ground targets are to be engaged.

Computer processing is not necessary for this activity and therefore, the system could be operated but with reduced capability if the computer were to malfunction. The error budget and reaction time for this mechanism is shown in Figures 15 and 16.

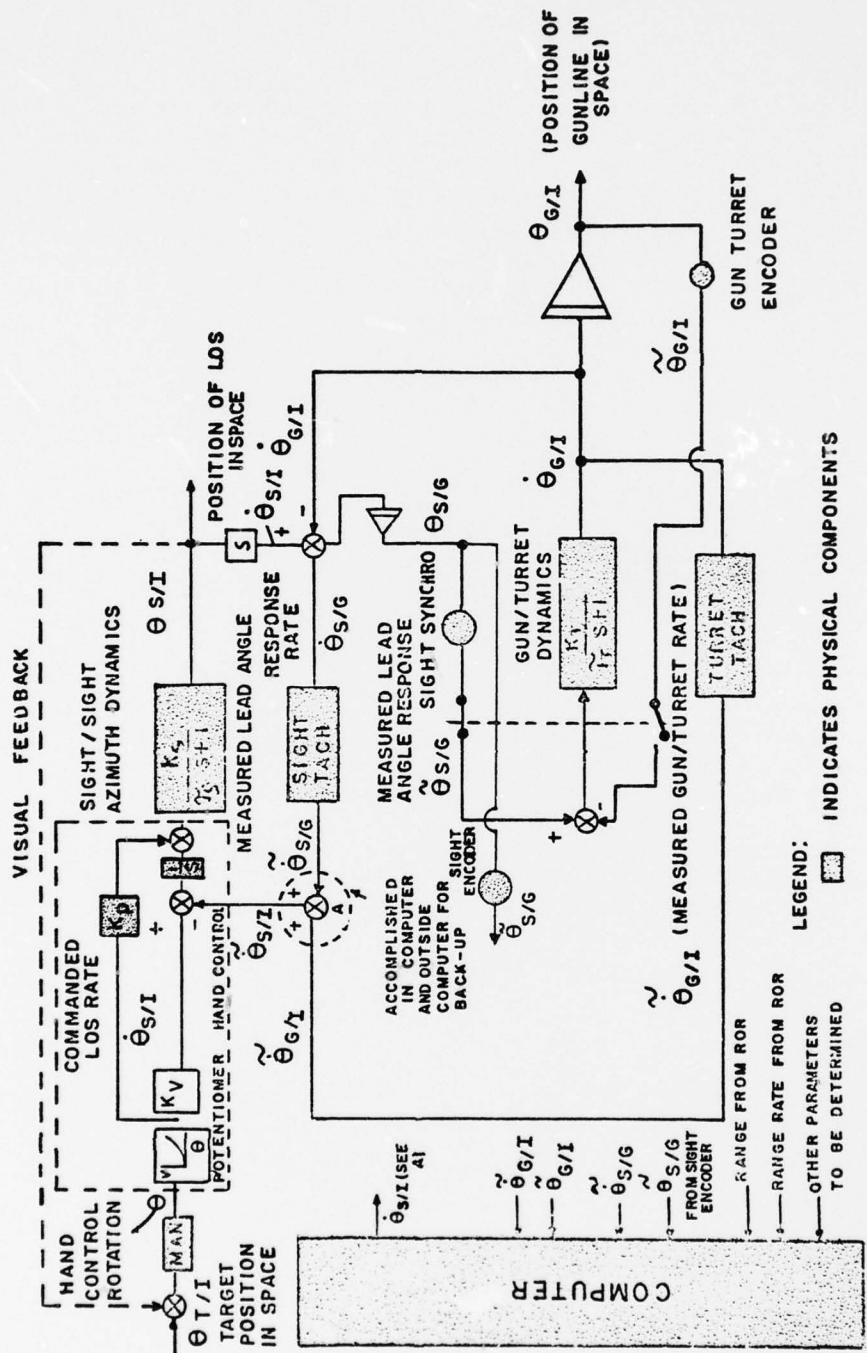

Figure 3. Rate Servo Sight Director System (Acquisition Mode)

COMPUTER STABILIZED AND CONTROLLED UNITY POWER DIRECTOR SIGHT

The design philosophy adhered to throughout the study was one of strict economic prudence; make use of as much of the present system componentry as possible while concentrating on improving overall accuracy and reduction of strain on the gunner. In keeping with this goal, a modified VADS sight will be utilized in the design and fabrication of the computer stabilized director sight (Figure 4). Inputs to the computer required to stabilize the sight-line, generate gun/turret commands and provide for regenerative track will be supplied by this device. The modified sight will utilize two digital tachometer shaft encoder packages (Baldwin Electronics Corp), and two torque motors (Aeroflex Electronics Corp) thus eliminating the gyro motor eddy current disk, range magnet, range current supply, nutation damper, and the existing elevation torquer which is inadequate for this application. The digital tachometer shaft encoder package is shown in Figure 5. The encoder shown contains an optical system which will resolve 15 bits absolute and two 90° phased rate tracks of 12,500 cycles each. The electronics will count both leading and trailing pulse edges thus giving a readout capability of 50,000 counts per encoder revolution. The synchros presently mounted to the gimbal will be retained for the acquisition mode, but will be shifted to new positions.

The elevation and train sigma (σ) factors required to improve gyro response in the current VADS system will be removed by replacing the elevation linkage with a steel band/2:1 pulley combination, providing for a fixed mounting of the presently moveable reticle mirror, and inclusion of a correcting glass in lieu of a lens (Figure 6).

The servo electronics required for the director will be housed within the case and the present mechanical caging and uncaging device will also be retained.

GUN/TURRET SENSORS

To close the loop around the gun/turret position servo when weapon pointing commands are introduced, as well as providing for sight-line stabilization add regeneration inputs to the computer, sensors mounted to the gun and turret are required. Mounting of these devices to a towed system are depicted in Figures 7 and 8.

The self propelled system will utilize identical sensors at the same locations. Both the elevation and train packages will contain the combination digital tachometers and shaft encoders that were described within the Director Sight Section.

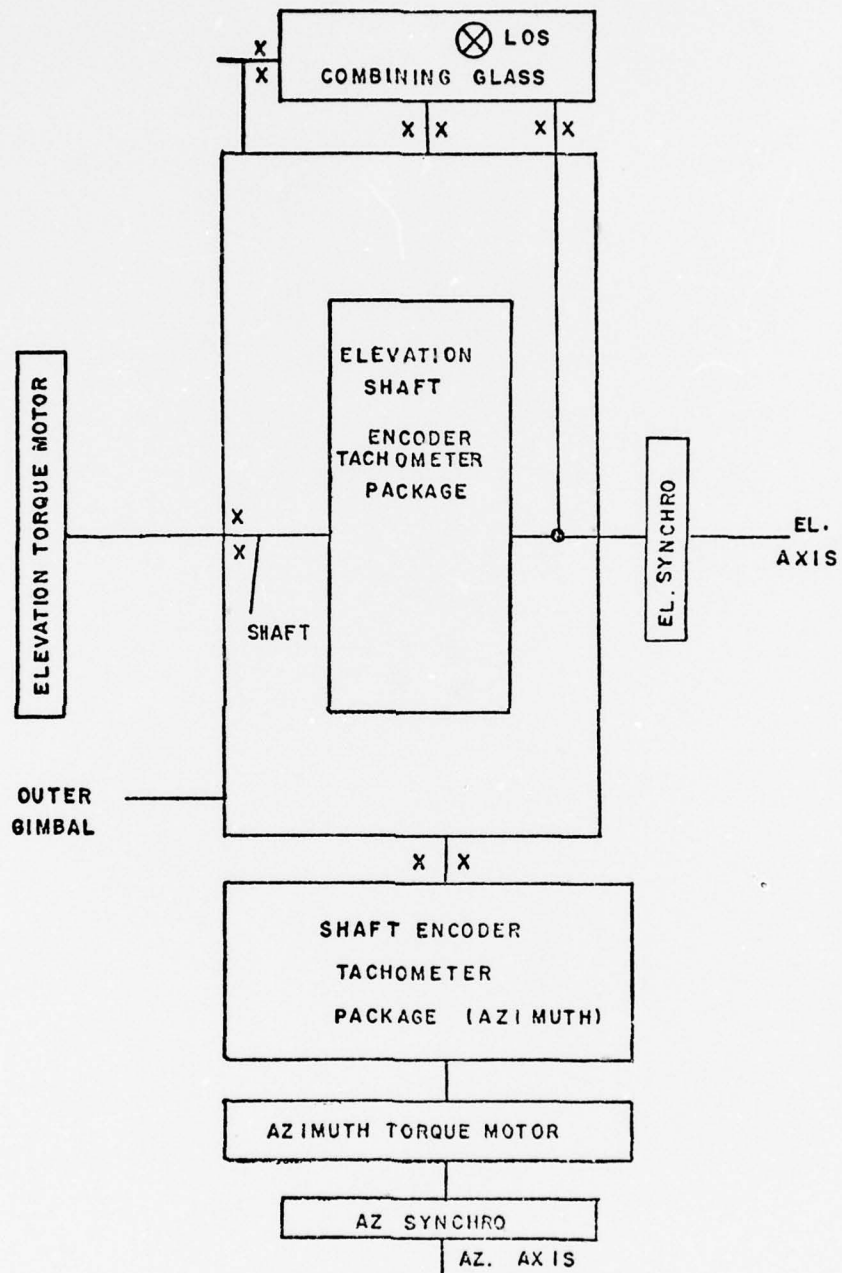

Figure 4. Proposed Director Sight (Modified M61)

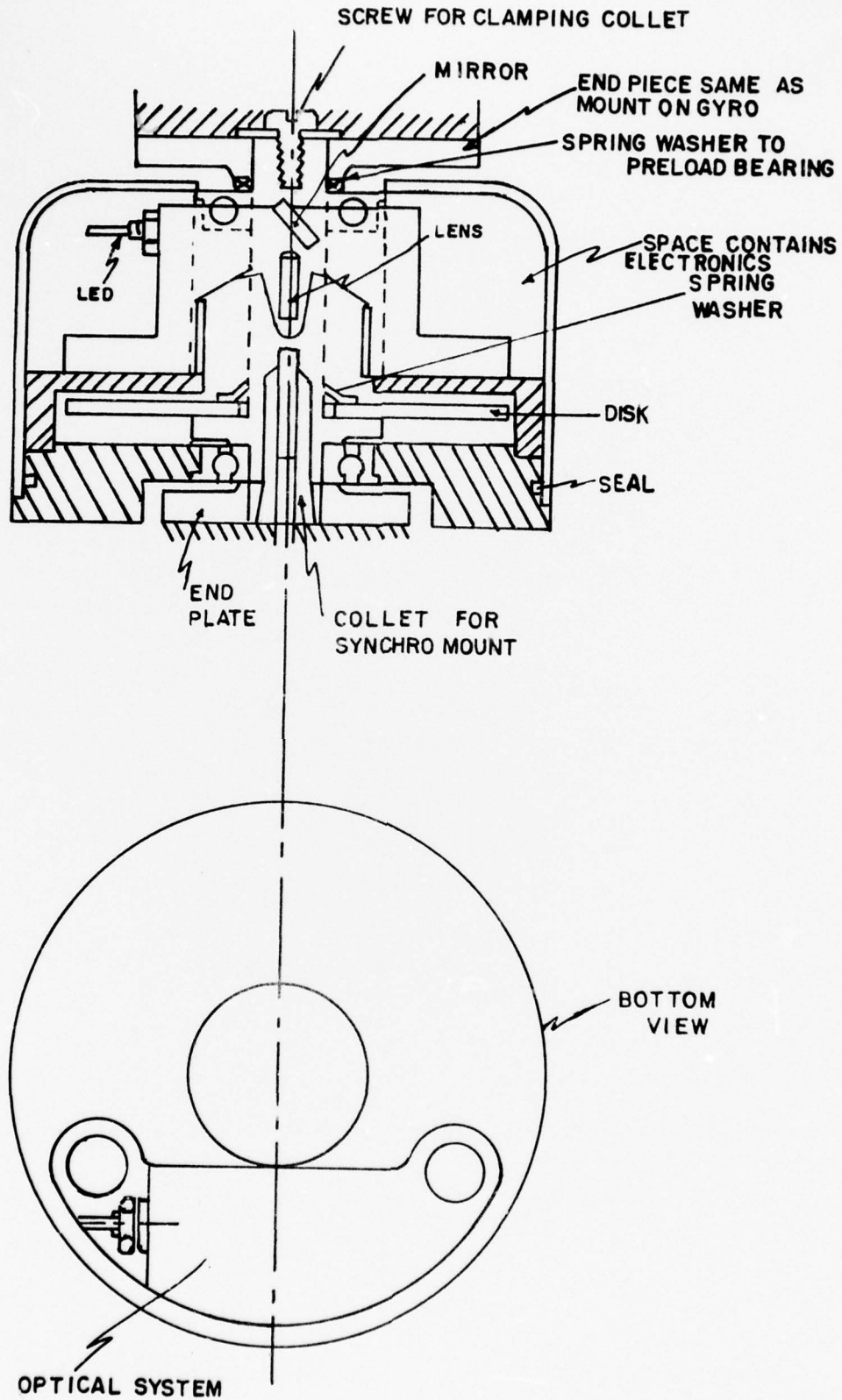

Figure 5. Encoder Tachometer Package

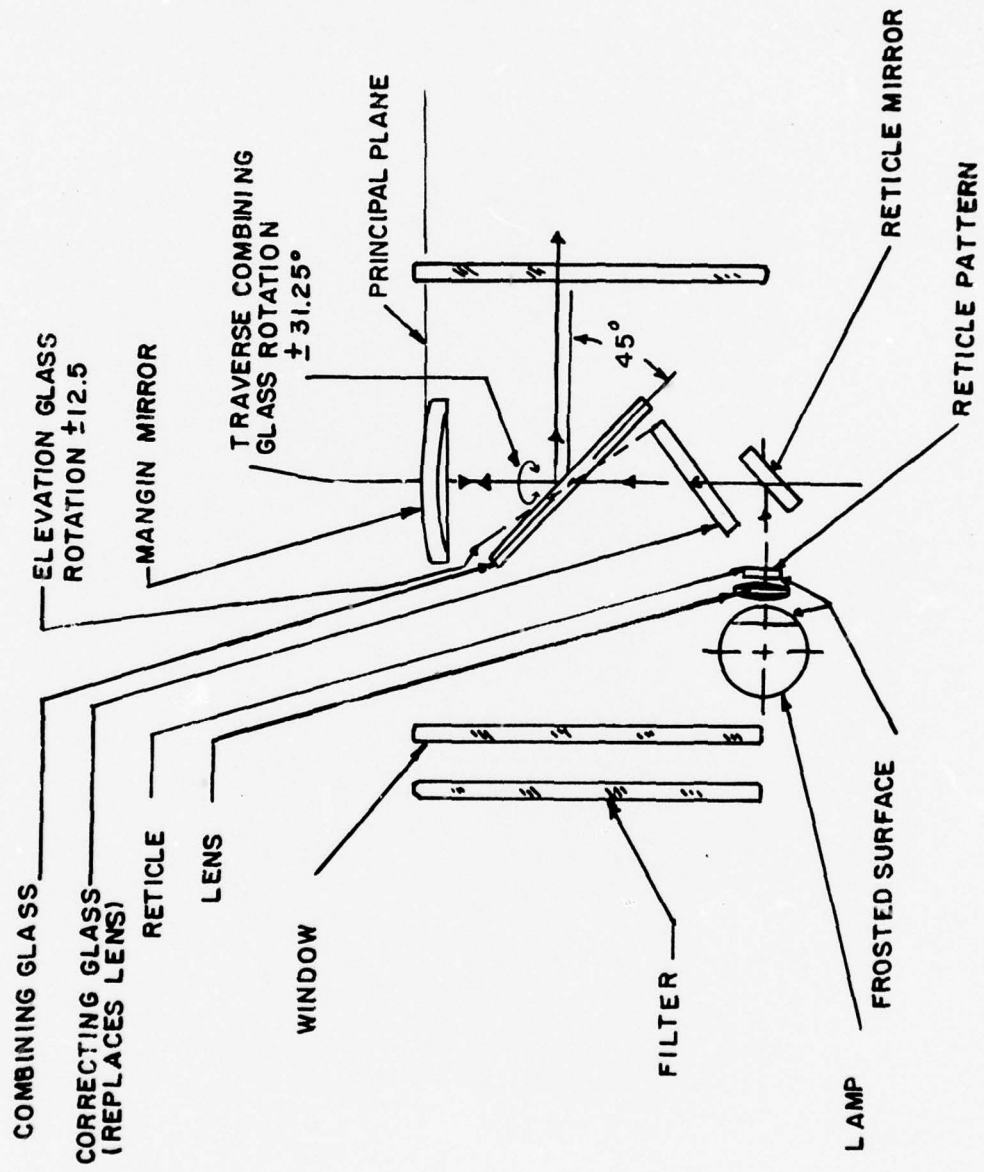

Figure 6. Director Sight Optical Schematic

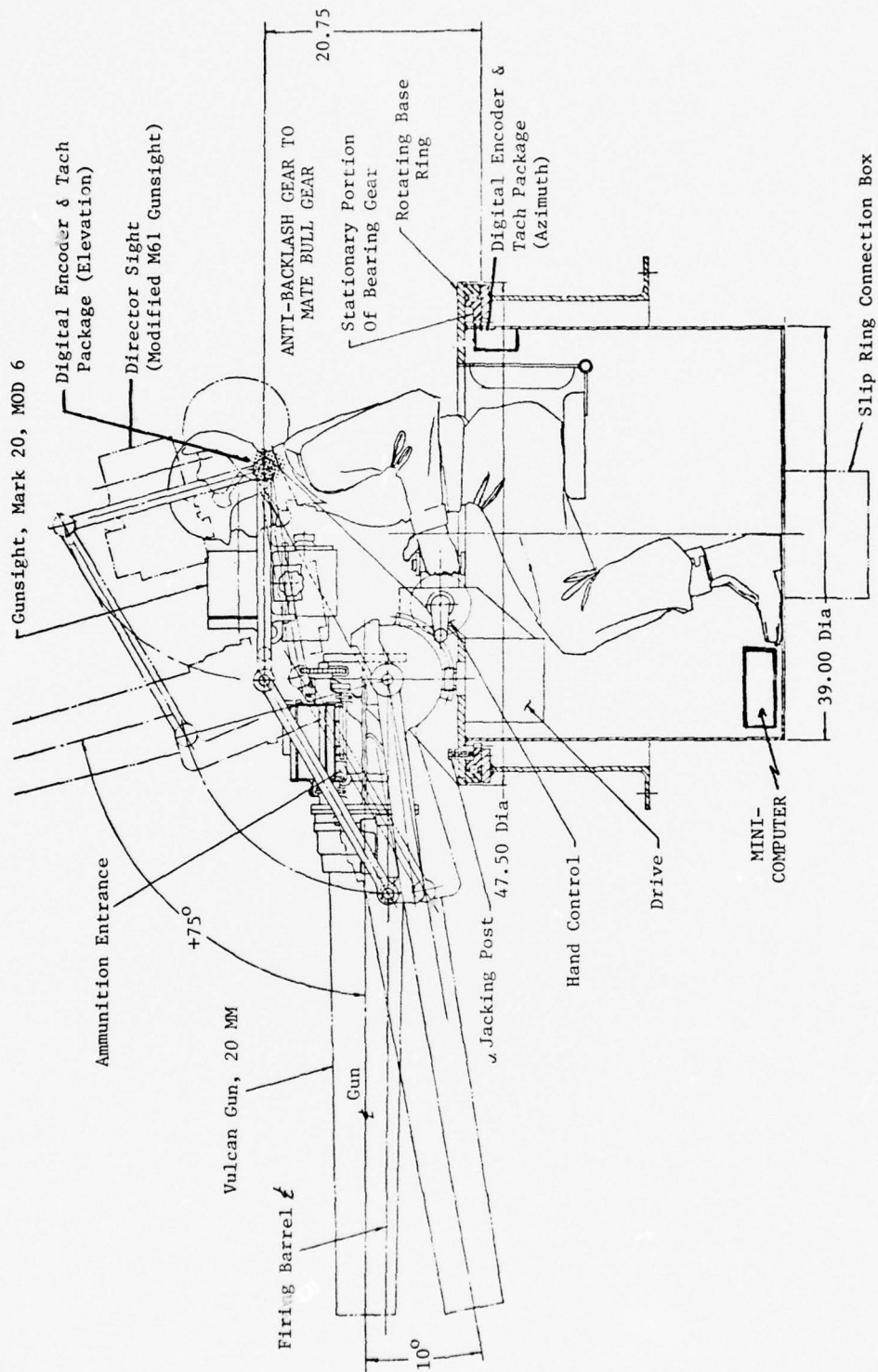

Figure 7. Mounting of Gun/Turret Sensors (Elevation View)

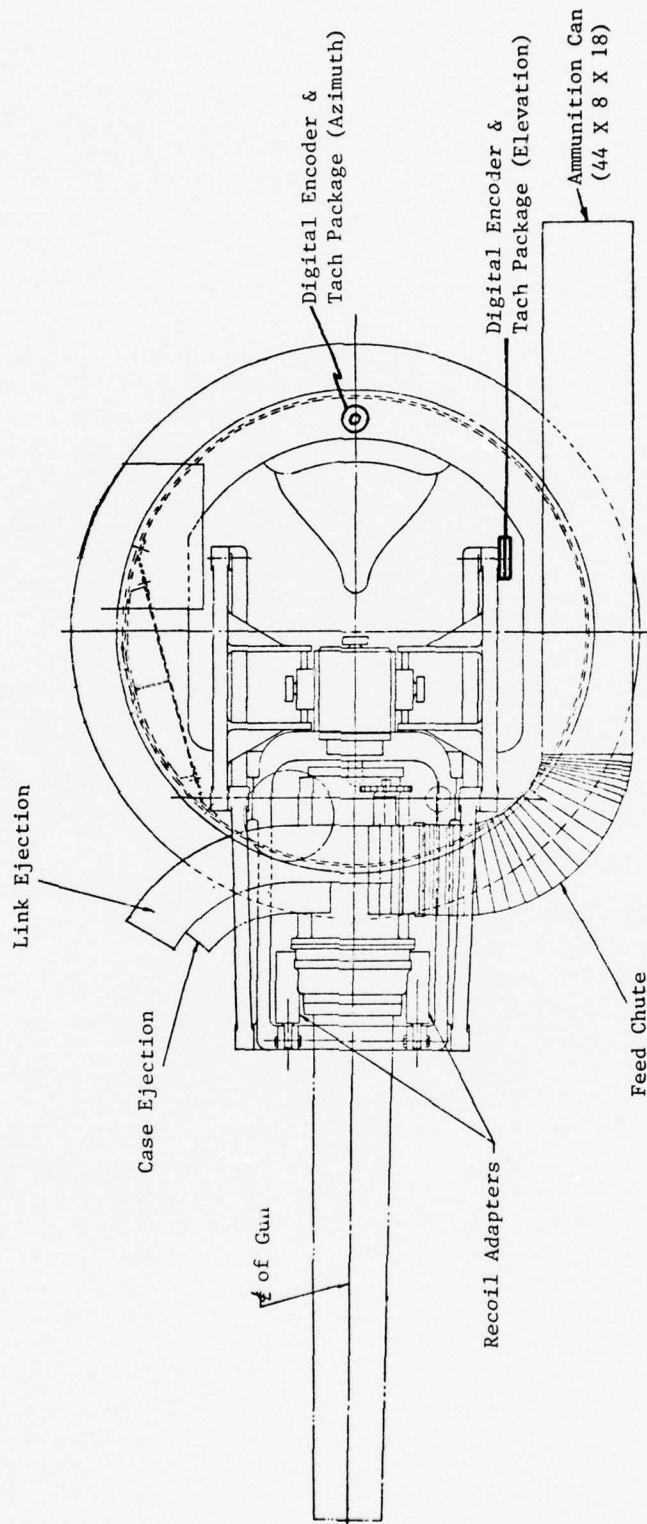

Figure 8. Mounting of Gun/Turret Sensors (Plan View)

The configuration shown in Figure 9 was designed to minimize the inaccuracies and disturbances to tracking resulting from turret bullgear backlash. By keeping the pinion of the sensor package up against the bullgear via a light servo motor it is expected that measurement errors associated with sensing turret position and rate can be reduced to a tolerable quantity.

FIRE CONTROL COMPUTER AND ITS MECHANIZATION

The CDC 469 digital computer was utilized in the design study to solve the fire control problem. An envelope sketch is shown in Figure 10: Mounting of this device for both the towed and self-propelled Vulcan is shown in Figures 7 and 11. A first order simplified mechanization for computing gun/turret commands was elected for the brassboard model system. A flow diagram for the computation of the algorithms is shown in Figure 12. Inputs to the computer required for generating gun/turret commands, line of sight regeneration commands and sight stabilization commands are:

1. Position and rate with respect to the gun.
2. Gun/turret position and rate with respect to the hull.
3. Range and range rate.
4. Meteorological data.
5. Pitch and roll of the mount.
6. Muzzle velocity.

For the brassboard metro data, pitch, roll and muzzle velocity will be toggled manually through the computers front panel.

Signals required to switch from acquisition to gun pointing are range and radar lock-on. Gun pointing commands will be generated but inhibited from output during acquisition by operating upon estimates of target range and velocity set into the computer via the control panel by the gunner. This will be accomplished mainly to reduce the effect of filter settling on overall system reaction time. Once the system has switched into the gun pointing mode the outputted gun/turret commands will be controlled to gradually reach their theoretically correct values in about one-half a second. Gun/turret servo transients due to introduction of this signal, can be reduced to a minimum if this approach is pursued. A similar technique must be applied to the sight's regeneration signal. Sight servo saturation limits determine how fast the theoretically correct input can be introduced. Provisions to reacquire the target in the event of loss of radar lock either during firing or when the target seeks cloud cover requires the radar lock on signal, weapon firing signal,

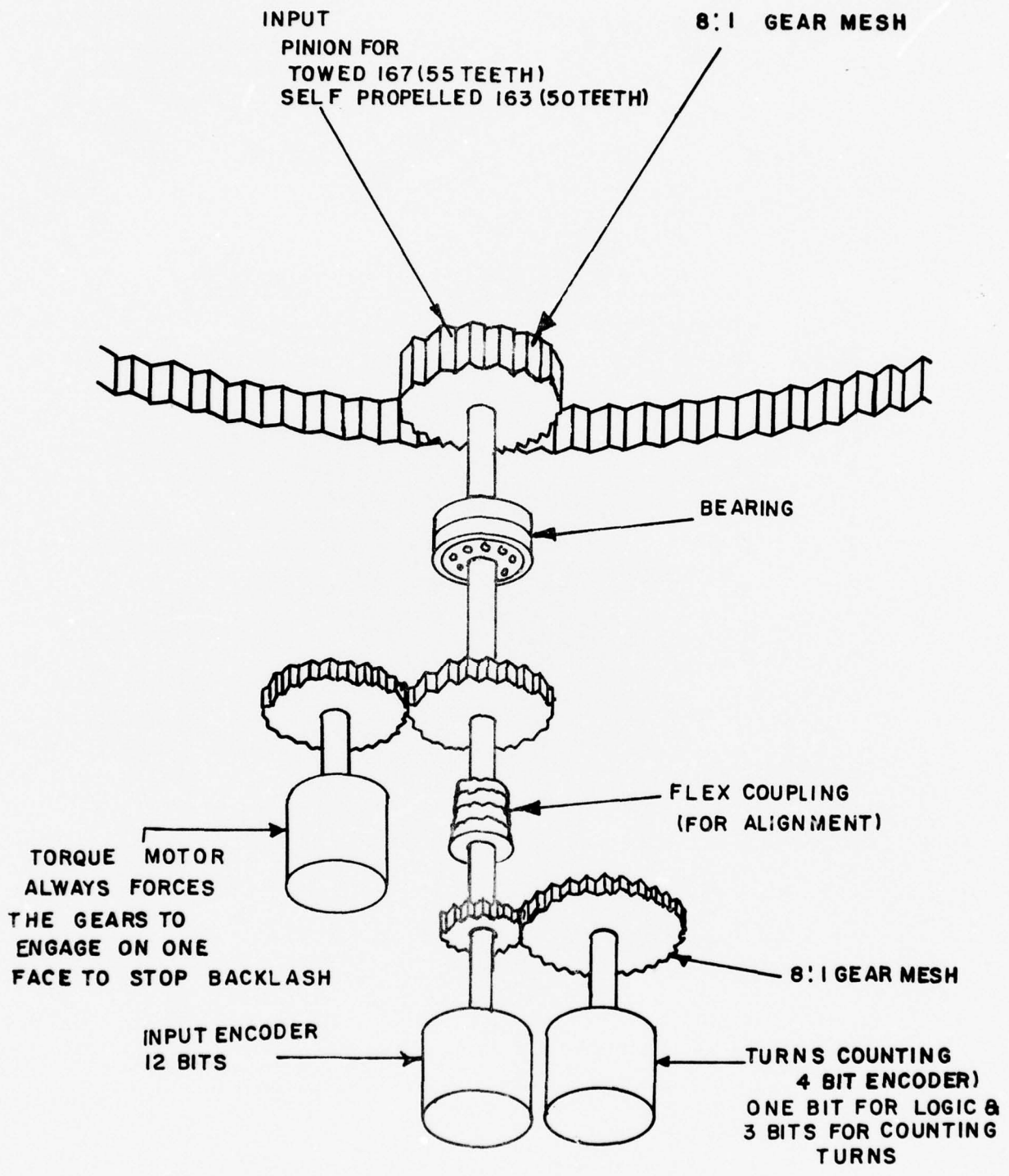

NOTE: SAME GEAR BOX CAN BE USED FOR BOTH TOWED OR SELF PROPELLED VADS, CHANGE INPUT PINNION ONLY

Figure 9. Turret Sensor Package

 AREA OF MAXIMUM HEAT TRANSFER

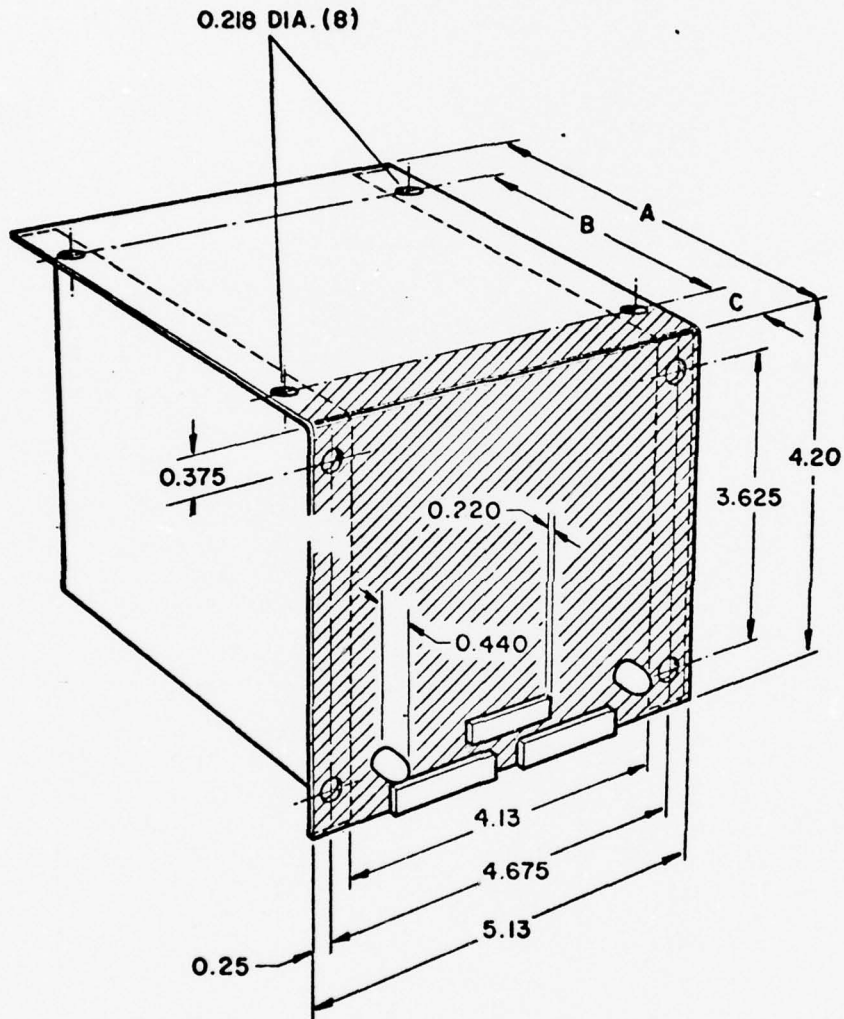

MEMORY SIZE	4K	8K	12K	16K
A - INCHES *	2.7	3.0	4.7	5.0
B - INCHES	NA	2.0	3.0	3.0
C - INCHES	0.5	0.5	1.0	1.0
WEIGHT - POUNDS *	2.1	2.75	3.4	4.6
* MAXIMUMS				

Figure 10. CDC 469 Envelope Sketch

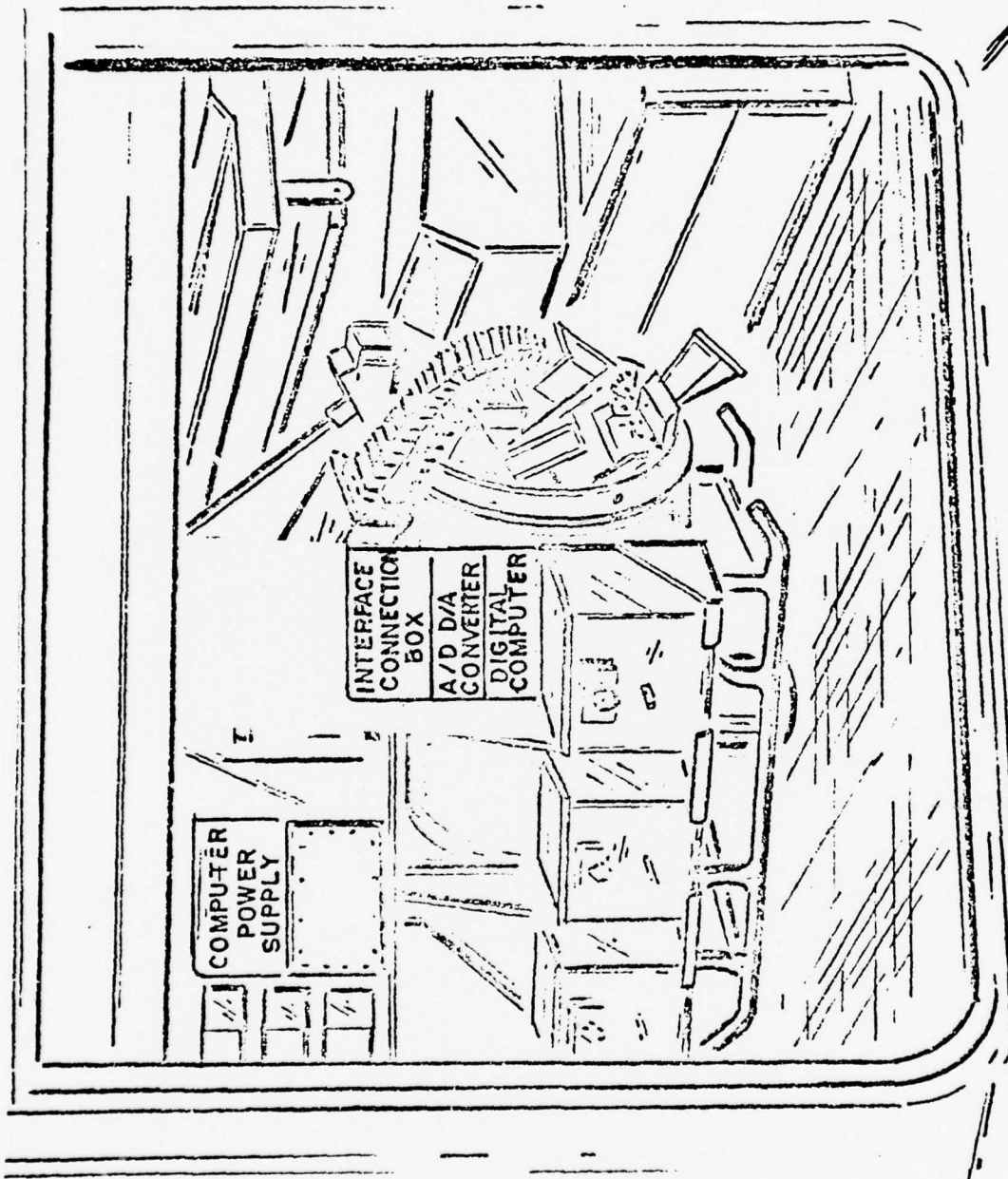

Figure 11. Vulcan Director System

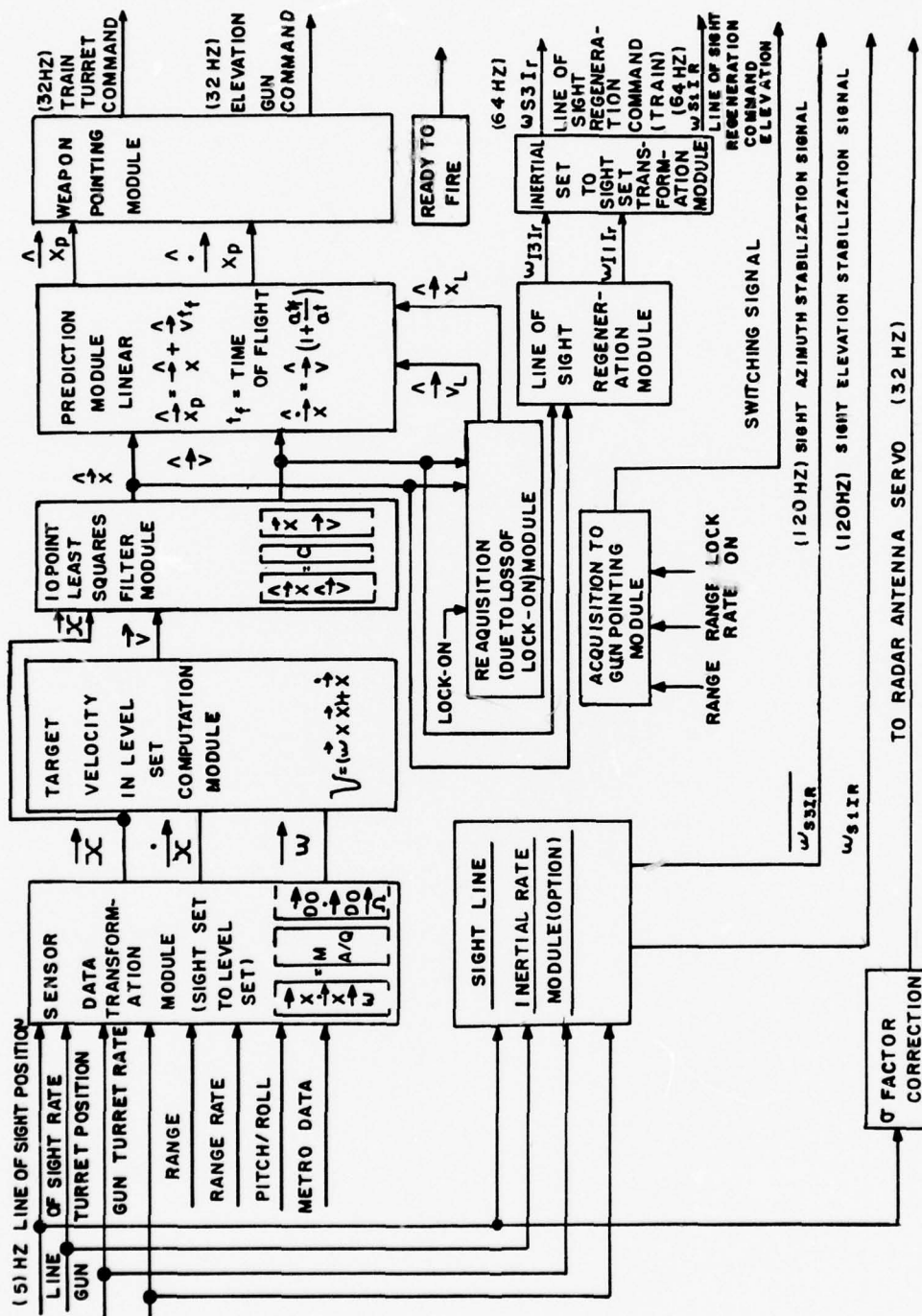

Figure 12. Algorithm Flow Diagram

weapon firing signal, and appropriate computation algorithms. Smoothed velocity \hat{v} and position \hat{x} extrapolated from the last known measures of these quantities will be utilized in the linear prediction module to drive the gun/turret in the event of loss of radar lock. The line of sight regeneration module will also operate on these quantities if the target is lost to the radar.

The logic for the ready to fire light presently resides in the sight current generator. This function must be provided by the computer. The inputs to the logic which will provide a ready to fire signal will be; radar lock on, gun elevation less than 80° , lead angle less than 25° , present range less than 1600 meters and smoothing filter settled. A signal indicating that the smoothing filter has settled will come on after a fixed delay less than two seconds after lock on is achieved. A minimum of 4K of core will be required with a duty cycle approaching 80% if the line of sight stabilization signal is output 64 times per second. Each of the signals emanating from the computer must be filtered before it commands an appropriate device. A first order lag whose break frequency is one quarter of the sampling rate should suffice.

MODIFIED VULCAN HAND CONTROL

The present Vulcan hand control will be electronically modified for the brassboard system. Figure 13 is a schematic depicting the required changes which will result in producing an output signal proportional to the displacement of the hand control itself plus the integral of displacement signal.

SYSTEM INTERFACING

A tentative cabling interconnection diagram is shown in Figure 14. Approximately six (6) new cables are required for the brassboard system. In addition, radar unit six will contain the acquisition to track relays (TTL relays) and digital to synchro converters. Radar unit four will house the radar to computer converters (addressable registers and miscellaneous electronics).

Table 1 provides a list of those signals associated with each cable. The signals are either computer inputs or outputs. The interface devices required with totals are also shown. It is envisioned that the D/A converters will be separately housed from the computer as illustrated in Figure 11. Also contained there will be the bi-polar A/D converter and multiplexer, synchro to digital converters and TTL compatible logic.

It is conceivable that the remaining addressable registers and lamp driver will also reside there. The possibility exists however, that those registers required for the sight will be housed within it.

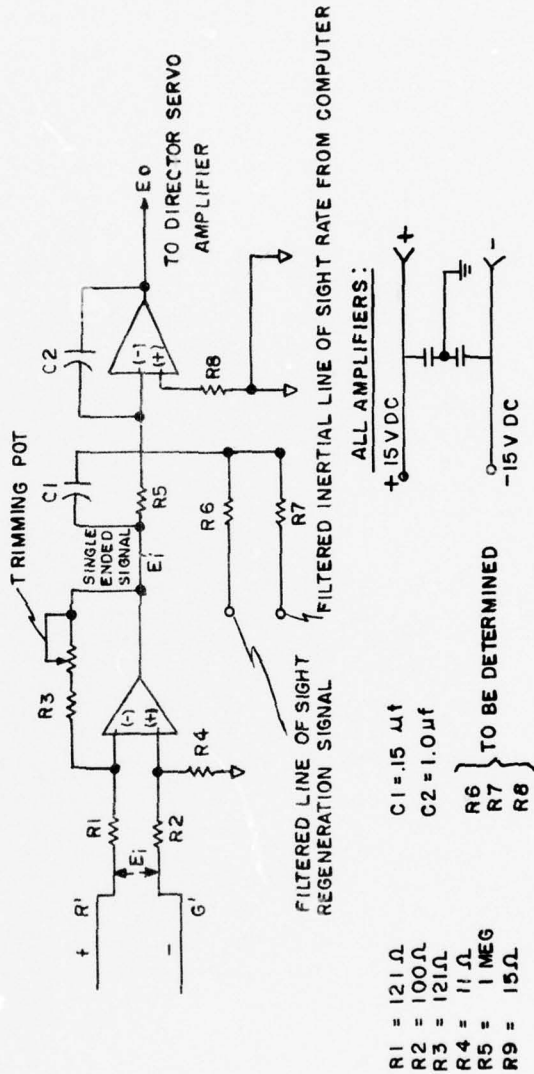
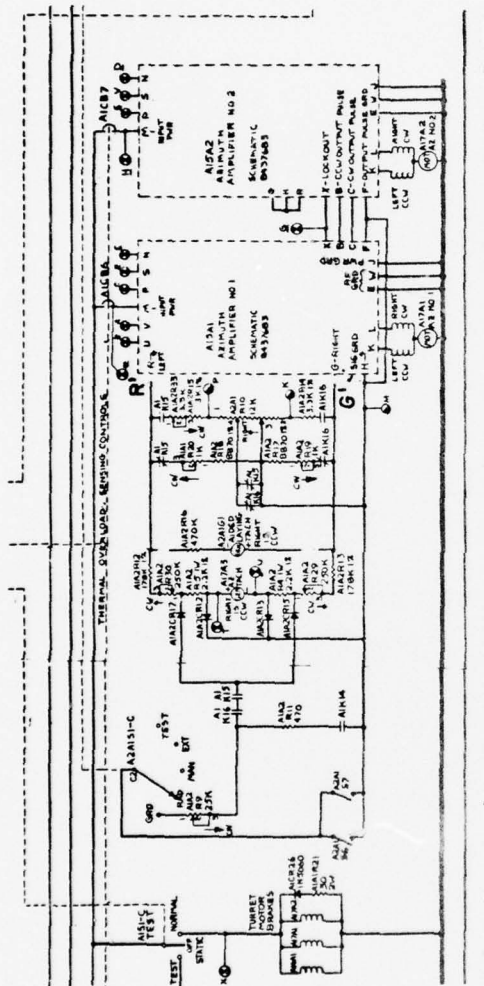

Figure 13. Present Vulcan Hand Control MOD Schematic

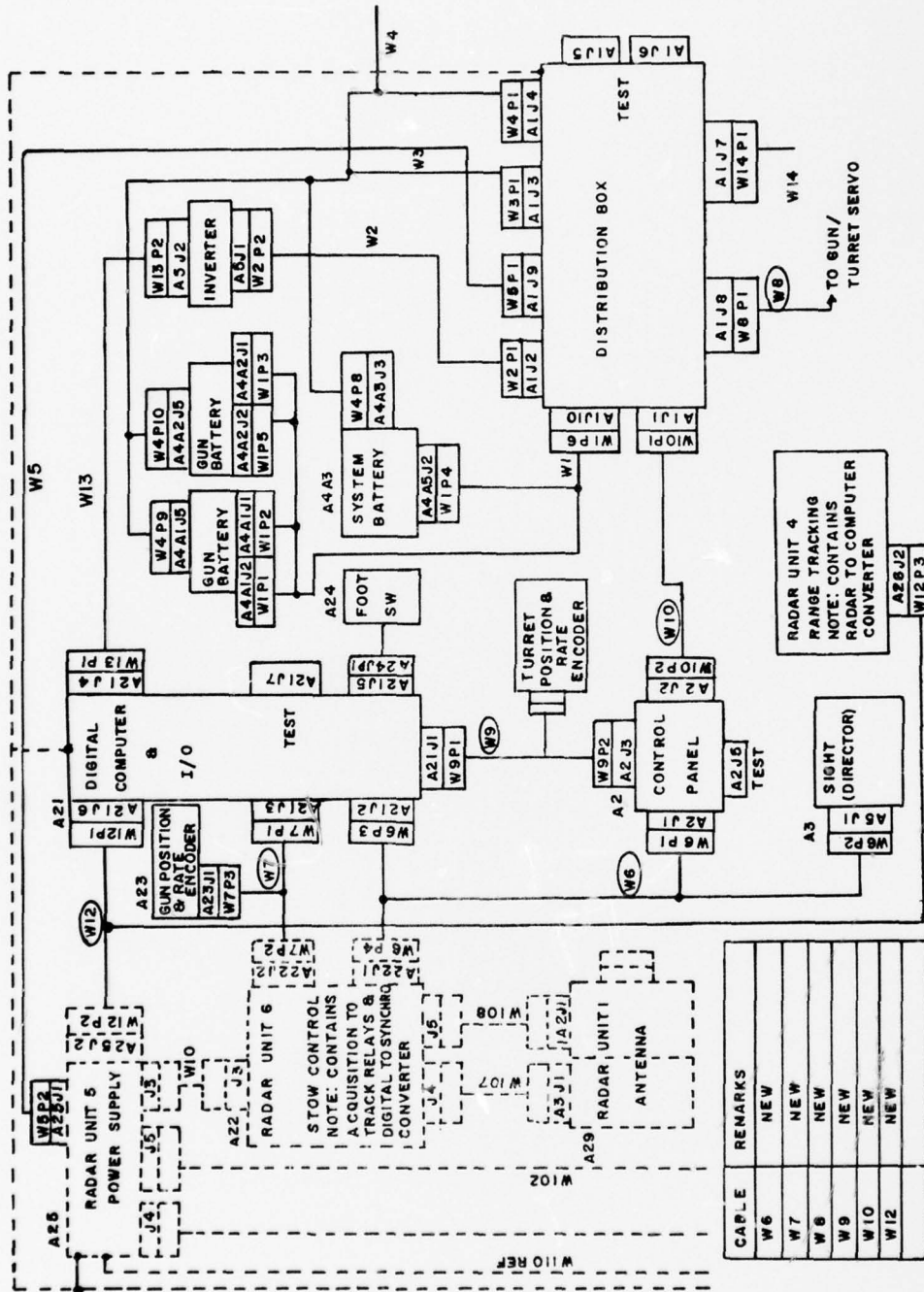

Figure 14. Tentative Cablin Interconnection Diagram Director System

TABLE 1. Tentative Cabling List

INPUTS TO COMPUTER	CABLE	INTERFACE DEVICE	TOTALS	
			INTERNAL WIRING	MISCELLANEOUS
LINE OF SIGHT (AZ, EL) POSITION FROM ENCODER & SYNCHRO TO COMPUTER	W9 NEW	ADDRESSABLE REGISTER-ENCODER	}	}
LINE OF SIGHT (AZ, EL) RATE FROM ENCODER & SYNCHRO TO COMPUTER	W9 NEW	SYNCHRO TO DIGITAL CONVERTER-SYNCHRO		
GUN POSITION (EL) TO COMPUTER	W7 NEW	ADDRESSABLE REGISTER		
TURRET POSITION (ON AZ) TO COMPUTER	W9 NEW	"		
RADAR RANGE TO COMPUTER	W12 NEW	"		
RADAR RANGE RATE TO COMPUTER	W12 NEW	"		
PITCH & ROLL TO COMPUTER	W9 NEW	BI-POLAR A/D & MULTIPLEXER		
METRO DATA TO COMPUTER	W9 NEW	"		
RADAR LOCK ON TO COMPUTER	W12 NEW	TTL COMPATIBLE LOGIC		
ACTION SWITCH SIGNAL TO COMPUTER	W9 NEW	"		
GUN RATE (EL) TO COMPUTER	W7 NEW	ADDRESSABLE REGISTER		
TURRET RATE (AZ) TO COMPUTER	W9 NEW	"		
MANUAL RANGE & VELOCITY OF TGT TO COMPUTER	W9 NEW	BI-POLAR A/D & MULTIPLEXER		
MUZZLE VELOCITY TO COMPUTER	W9 NEW	"		
HAND CONTROL SIGNAL TO COMPUTER (AZ)	W9 NEW	"		
HAND CONTROL SIGNAL TO COMPUTER (EL)	W9 NEW	"		
OUTPUTS FROM COMPUTER			NEW	OLD NEW
RADAR ANTENNA POSITION SIGNAL (TR) TO ANTENNA SERVO	W6 TO W108	DIGITAL TO SYNCHRO CONVERTER		
RADAR ANTENNA POSITION SIGNAL (EL) TO ANTENNA SERVO	W6 TO W107	"		
SIGHT AZIMUTH STABILIZATION SIGNAL TO SIGHT/HAND CONTROL	W6	D/A		
SIGHT ELEVATION STABILIZATION SIGNAL TO SIGHT/HAND CONTROL	W6	D/A		
SWITCHING SIGNAL - ACQ. TO TRACKING	W6	TTL RELAY		
LINE OF SIGHT REGENERATION - COMMAND AZ. TO HAND CONTROL	W6	D/A		
LINE OF SIGHT REGENERATION - COMMAND EL. TO HAND CONTROL	W6	D/A		
READY TO FIRE SIGNAL TO SIGHT	W6	LAMP DRIVER		
GUN COMMAND TO GUN SERVO	W9 TO W10 TO W8	D/A		
TURRET COMMAND TO TURRET SERVO	W9 TO W10 TO W8	"		
GUN AIDING TO GUN SERVO	W9 TO W10 TO W8	"		
TURRET AIDING TO TURRET SERVO	W9 TO W10 TO W8	"		
MISCELLANEOUS				
HAND CONTROL SIGNAL AZ. TO SIGHT		ADDRESSABLE REGISTERS 9		TTL RELAY 2
HAND CONTROL SIGNAL EL. TO SIGHT		SYNCHRO TO DIGITAL CONV 2		D/A CONVERTER 8
		BI-POLAR A/D & MULTIPLEXER 2		LAMP DRIVER 1
		DIGITAL TO SYNCHRO CONV 2		

SUMMARY OF VULCAN HARDWARE ADDITIONS REQUIRED
TO PROVIDE A DIRECTOR CAPABILITY

Physical modifications to the existing Vulcan Fire Control system will consist of modifying the present M61 sight and hand control, replacing the sight current generator (SCG) with a "mini" digital computer (CDC 469) programmed with various fire control algorithms, replacing the gun/turret sensors (digital encoders and tachs) and providing for interface unit electronics as follows: A/D, D/A, digital to synchro converters for the antenna sigma factor correction, computer output filters, and power supplies.

All of the units for the brassboard system will be built to meet the demands of a proving grounds environment.

DIRECTOR SYSTEM ERROR BUDGET

Figure 15 was configured to show the relative magnitudes of each contributing source of error and the design goal for the director type system. The accuracy improvements shown are quite conservative. They were estimated by considering the preliminary results of our system simulation in addition to field and contractor data. The detailed simulation to be provided under another cover will bear credence to the accuracy goal being sought.

DIRECTOR SYSTEM REACTION TIME

An estimate of director type system reaction time Figure 16 was made in which it was assumed that the target was detected 180° in azimuth away from the weapon station at a range of 3000 meters. The sequence of events required from detection to fire are shown. The total estimated reaction time is between 5.0 and 8.5 seconds. These figures are based upon a mixture of field and preliminary simulation data. For the same scenario the present Vulcan's reaction time is between 9.0 and 10.0 seconds.

PROGRAM COSTS

Given below are the hours and associated costs of executing a program with the objective of designing, fabricating and testing a "brassboard" of the fire control system described in this report. It is anticipated that the theoretical design of the system will be developed in-house by Frankford Arsenal. This design will be embodied into a specification that will form the basis for the "brassboard's" construction.

NOMINAL ERROR BUDGET

PRESENT VULCAN		DIRECTOR VULCAN	
RMS	ERROR	RMS	ERROR
TRACKING	13.0		3.6
REFLECTED TO OUTPUT			
RANGE	2.5		2.5
RANGE RATE	.7		.7
F/C MECH	6.0		1.0
SERVO DRIVE	5.5		2.4
MUZZLE VEL.	1.5		1.5
BORESIGHT	2.0		2.0
TOTAL (MILS)	15.8		5.7

VELOCITY = 231 M/SEC

ALTITUDE = 300 M

CROSSING RANGE = 300 M

INTERCEPT RANGE = 1200 M

Figure 15. Error Budget

SEQUENCE OF EVENTS FROM DETECTION
TO FIRE (DIRECTOR SYSTEM)

EVENTS

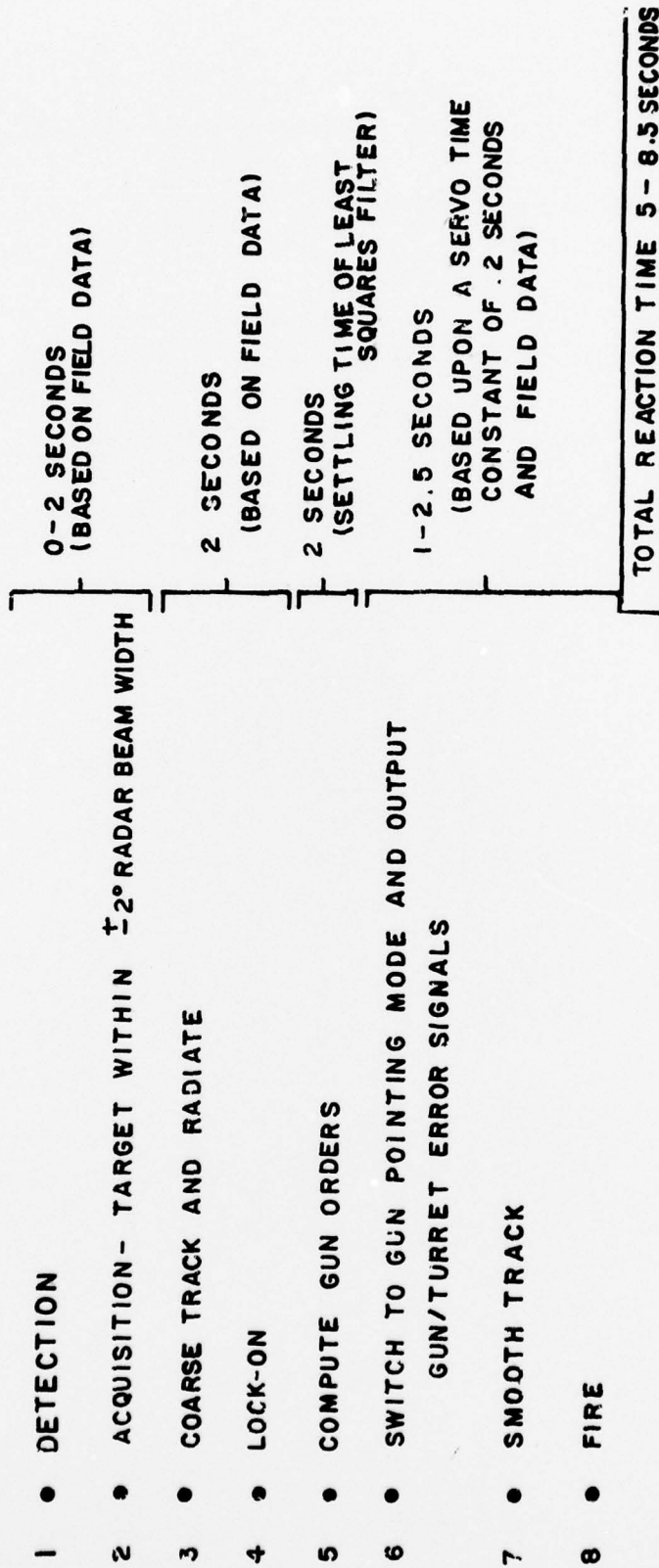

NOTE: THE ACQUISITION MODE IS COMPRISED OF EVENTS

1. TO 5.

THE GUN POINTING MODE IS COMPRISED OF EVENTS 6. TO 8.

Figure 16. Sequence of Events from Detection to Fire (Director System)

Test and evaluation of the equipment will be conducted by utilizing the Vulcan Dynamic Field Evaluator (DFE).⁵ Some modification of this equipment will be required to make it compatible with the "brassboard" fire control system.

HOURS REQUIRED TO DESIGN, FABRICATE AND CHECKOUT ONE (1)

BRASSBOARD DIRECTOR SYSTEM

<u>ENGINEERING</u>	<u>MAN - MONTHS</u>
Project Engineer	12
Control Systems Engineer	9
Mechanical Engineer	7
Mathematician	6
Electronics Engineer	26
Real Time Programmer	9
Optical Engineer	6
Technical Writer	6
	<hr/>
	81 Man - Months
 <u>DESIGN</u>	
Designers (Electro-Mechanical)	18
Draftsmen	12
	<hr/>
	30 Man - Months
 <u>FABRICATION AND CHECKOUT</u>	
Machinists	12
Electronic Technicians	12
Optical Technicians	3
	<hr/>
	27 Man - Months

⁵
The Vulcan Air Defense System (VADS) Dynamic Field Evaluator (DFE) For the Gun Air Defense Effectiveness Study (GADES), by Robert S. Segal, Frankford Arsenal Report Number M72-29-1, November 1971.

MONTHLY RATES WITH OVERHEAD

Engineering	\$5200/ man - months
Design	
Fabrication and Checkout	\$4300/ man - months
	\$3466/ man- months

CONTRACTOR COSTS

Engineering	\$5200 x 81 = \$421,200
Design	\$4300 x 30 = \$129,000
Fabrication and Checkout	\$3466 x 27 = \$ 93,582

TOTAL COST FOR LABOR = \$643,782

MATERIAL COSTS

Computer CDC - 469	\$35,000
Input/output Converter	\$10,000
New Cables (6)	\$ 2,500

SIGHT

2 Torquers	\$ 1,200
2 Shaft Encoder/tach Packages	\$15,000
2 Servo Amps	\$ 600
Miscellaneous Electronics	\$ 500
Wiring	\$ 25
2 Pullys and Steel Band	\$ 100
Correction Glass	\$ 50

HAND CONTROL

Miscellaneous Electronics	\$ 300
Wiring	\$ 25

RADAR ANTENNA SERVO INTERFACE

Digital to Synchro Converter (2)	\$ 300
Wiring	\$ 25

COMPUTER OUTPUT FILTERING

Miscellaneous Electronics	
a. Gun/Turret Channels (2)	\$ 150
b. Regeneration Track Channel (2)	\$ 150
c. Radar Antenna servo Channel (2)	\$ 150
d. Gun/Turret Aiding Channel (2) Velocity Lag	\$ 150

GUN/TURRET SENSORS PACKAGE

Gun	\$15,000
Turret	\$25,000

<u>ACQUISITION TO TRACK</u>	
<u>SWITCHING CIRCUITS (2)</u>	\$ 500

<u>DIGITAL CIRCUITRY FOR LINE OF</u>	
<u>SIGHT RATE FEEDBACK</u>	\$ 500

<u>RADAR INTERFACE WITH COMPUTER</u>	
<u>I/O CIRCUITRY</u>	\$ 700

<u>GUN/TURRET SERVO PREAMPS</u>	\$ 3,000
---------------------------------	----------

TOTAL COST FOR MATERIAL = \$111,000

GOVERNMENT COSTS

Frankford Arsenal costs include those incidentals to the preparation of the specification, placement of the contract, management/technical supervision of the effort from inception to completion, and test and evaluation of the equipment on the Vulcan Dynamic Field Evaluator at Fort Dix, New Jersey.

PREPARATION OF SPECIFICATION/PLACEMENT OF CONTRACT

Project Engineer	4 man - months
Control Systems Engineer	3 man - months
Electronics Engineer	2 man - months
Optical Engineer	1 man - month
Mechanical Engineer	1 man - month
Mathematician	1 man - month

TOTAL = 12 man - months

MANAGEMENT AND TECHNICAL SUPERVISION

Project Engineer	12 man - months
Control Systems Engineer	12 man - months
Electronics Engineer	12 man - months
Optical Engineer	3 man - months
Mechanical Engineer	6 man - months
Mathematician	6 man - months

TOTAL = 51 man - months

TEST AND EVALUATION

Project Engineer	2 man - months
Field Engineer	4 man - months
Gunners	4 man - months

TOTAL = 10 man - months

MATERIAL COSTS ASSOCIATED WITH TEST AND EVALUATION OF BRASSBOARD
FIRE CONTROL SYSTEM

Modify Vulcan Dynamic Field Evaluator	\$100,000
Frangible Ammunition	\$ 30,000
Data Processing	\$ 10,000

TOTAL COSTS = \$140,000

GOVERNMENT COSTS FOR LABOR

Preparation of Specification Placement of Contract

12 man - months x \$5200 = \$ 62,400

Management and Technical Supervision

51 man - months x \$5200 = \$265,200

Test and Evaluation

10 man - months x \$5200 = \$ 52,000

TOTAL COST FOR GOVERNMENT LABOR = \$379,400

GRAND TOTAL PROGRAM COST

Contractor Labor	-	\$ 643,782
Contractor Material	-	\$ 111,000
Material for Government Test and Evaluation	-	\$ 140,000
Government Labor	-	\$ 379,400

COST OF PROGRAM = \$1,274,182

"BRASSBOARD SCHEDULE"

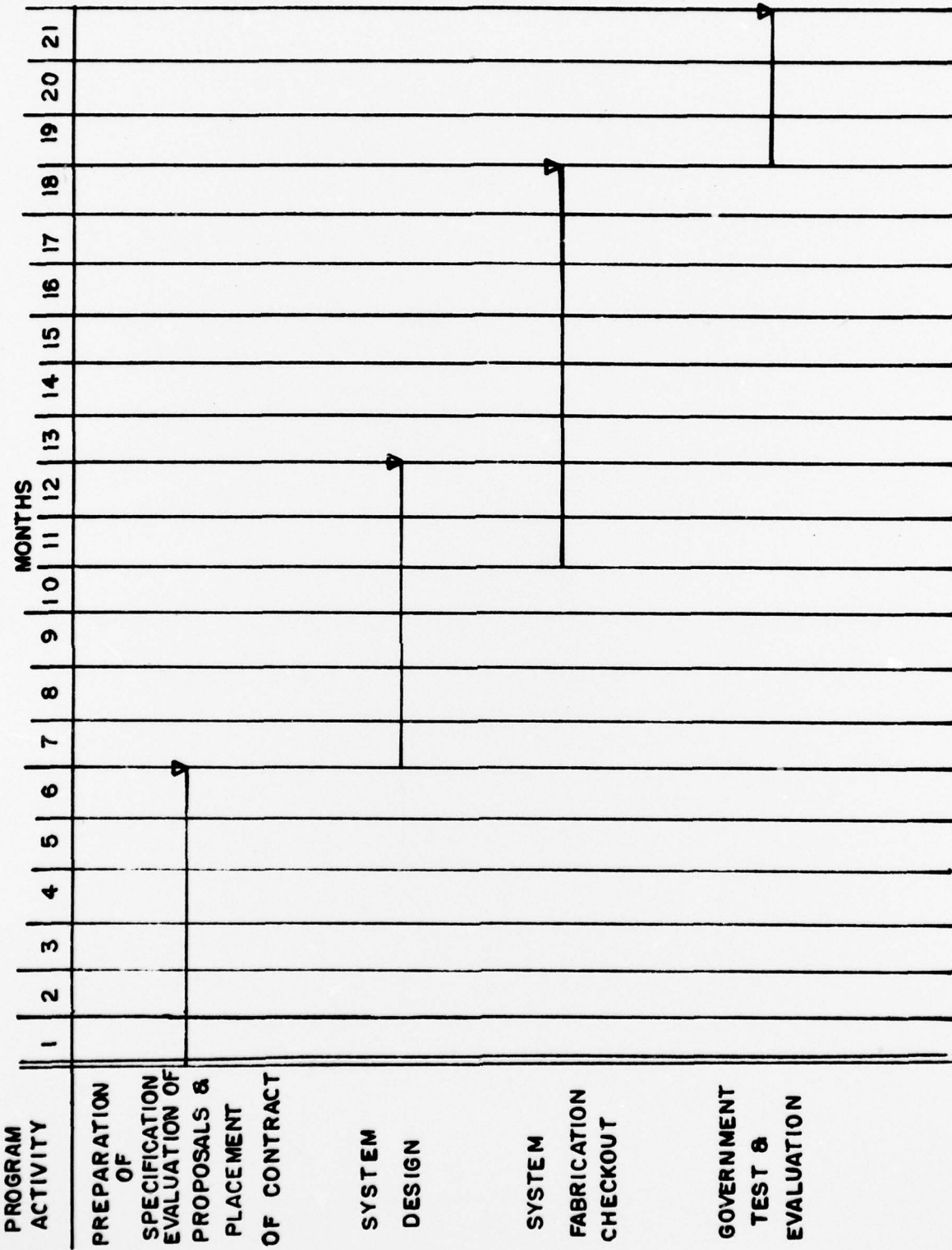

CONCLUSIONS

The system mechanization described herein employs a combination of digital tachometers, shaft encoders, and synchros to "unwind" the sight line from gun/turret motion. With this arrangement satisfactory weapon system performance is physically realizable, however, a computer software mechanization more complex than that required for fire control systems utilizing a gyro-stabilized sight ensues. In addition, a sensor capable of accurately measuring turret rate and position with respect to the hull is required whereas such a device is unnecessary in a gyro-sight fire control system configuration.

One therefore concludes that the director system described so far within the body of this report would be at least as expensive, reliable and maintainable as one utilizing a gyro-sight. This finding although seemingly unencouraging has a brighter side, since it has forced the synthesis of two alternative designs which "on paper", at least, appear to have some merit. The configurations which are outlined in this section, utilize position sensors only on their respective sights and gun/turret servos. This therefore eliminates four relatively expensive digital tachometers and reduces the cost per unit system considerably. The arrangements still require similar complex mechanizations as mentioned above, whether they be accomplished digitally or analog, however, unwanted line of sight motion due to gun dynamics is eliminated in addition to providing a sight that is somewhat physically less complex, cheaper, more reliable and easier to maintain than one realizable with rate gyro sensors. Let us now turn our attention to the first alternative.

Figure 17 is a single axis schematic of the control system whereby position sensors alone are utilized to solve the fire control problems. The control loops shown are essentially equivalent to those appearing in Figure 2 with two exceptions: The computed angular rate of the line of sight in inertial space ($\ddot{\theta}_{S/I}$) is not required for stabilization and the commanded line of sight rate ($\dot{\theta}_{S/I}$) derivable from hand control signals is utilized in the fire control prediction algorithm to point the weapon and provide for regeneration. As may be seen from Figure 17 the position of the sight line with respect to the gun, $\tilde{\theta}_{S/G}$, is measured by a position sensor, in this case the present synchro, placed within the sight unit (Figure 18). If it is assumed that the hull is stationary, the position sensor on the gun/turret, in this case a resolver, produces a signal equal to the angular position of the gun in inertial space ($\tilde{\theta}_{G/I}$). The addition of $\tilde{\theta}_{S/G}$ to $\tilde{\theta}_{G/I}$ results in $\tilde{\theta}_{S/I}$ which is the measured sight line position in space. In order to stabilize the sight line this quantity is nulled against the commanded line of sight position shown as an output of the hand control integrator (Figure 17). Hence the line of sight is isolated from gun/turret motion as before and is controlled solely by gunner command.

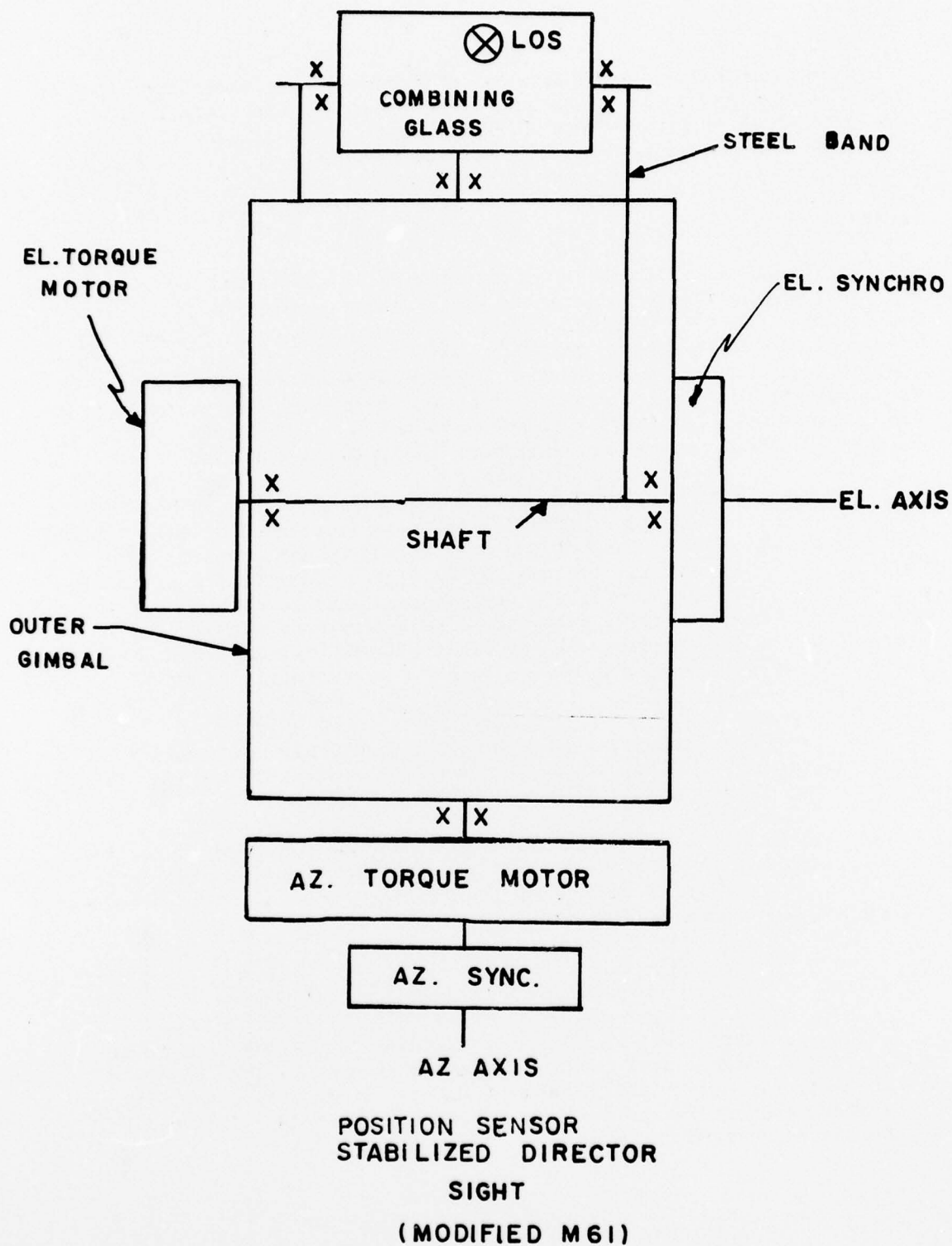

Figure 18. Position Sensor Stabilized Director Sight (Modified M61)

A second alternative (Figure 19) differentiates the computed line of sight position and nulls it against the commanded line of sight rate. This process of computing line of sight position and differentiating it to obtain an accurate rate could be accomplished either digitally within the computer or outside the computer by analog circuitry. The pros and cons of each approach need to be determined before the best scheme is decided upon.

In any of the aforementioned non-inertially stabilized schemes we are compromising apparent increased gun pointing accuracy over a burst (hull motion is not sensed) in favor of what appears to be a lower cost, more reliable and easier to maintain system. This situation causes somewhat of a dilemma, which is further compounded when one considers the advantages of increased weapon pointing accuracy over a burst in light of the Vulcan rounds sensitivity to uncompensatable wind effects, gunner "flinching" when the armament is fired, and smoke obscuration.

Since the questions that have been posed so far can only be answered by actual fabrication and comparative test, it is concluded that at least one "hybrid brassboard" Product Improved Vulcan be implemented. The "hybrid" would be primarily mechanized as a gyro-stabilized system. Since a gyro-stabilized system will require position sensors on both the sight and gun, the opportunity to mechanize a secondary mode, namely one of the aforementioned alternatives will be readily available. All that would be required over and above that necessary for a gyro-stabilized system would be the following;

1. Provisions to generate, feedback and null the computed line of sight rate or position signals. This could be accomplished either digitally or by analog circuitry techniques.
2. Inclusions of a turret position sensor package similar to that shown in Figure 9. There is a strong possibility that even this device would not be required if the present gun/turret servos were "tightened-up" and converted to high performance position servos.

RECOMMENDATIONS

It is estimated that the engineering labor and material costs involved in providing a dual capability into a gyro stabilized director system is in the order of \$25,000 to \$50,000. It is, therefore, strongly recommended that at least one "hybrid brassboard" Product Improved Vulcan be fabricated, tested and evaluated.

REFERENCES

1. Memorandum for Acting Assistant Secretary of the Army (R&D)
SUBJECT: Vulcan, Norman R. Augustine, Under Secretary of the Army
dated 9 June 1975.
2. Proposal for the Preliminary Design Study of a Director Type Fire
Control System for the Vulcan Air Defense System (VADS) by Robert
S. Segal, 1 March 1976.
3. "Some Applications of Servomechanisms and Analog Computers in Anti-
Aircraft Defense" by Mr. L. Ambrosini (at the time of writing),
Chief Engineer at Hispano Suiza Corp., Geneva, Switzerland, not
dated.
4. Final report for AFAADS Advanced Component Development Stabilized
Optical Tracker, Sperry Univac, Publication No. PX-8448, 15 April
1971.
5. The Vulcan Air Defense System (VADS) Dynamic Field Evaluator (DFE)
For the Gun Air Defense Effectiveness Study (GADES), by Robert S.
Segal, Frankford Arsenal Report Number M72-29-1, November 1972.