

AD-A034 453

INTERNATIONAL LASER SYSTEMS INC ORLANDO FLA
INDIRECT/AREA FIRE WEAPONS EFFECT SIMULATOR STUDY. VOLUME II. P--ETC(U)
JAN 77 R E ODOM

F/G 19/5

N61339-76-C-0070

UNCLASSIFIED

TND-TR-76-0002-VOL-2

NL

1 of 4
ADA034453



Report No. TND-TR 76-0002
Contract No. N61339-76-C-0070

12

FL

ADA 034453

VOLUME II

**INDIRECT/AREA FIRE WEAPONS EFFECT
~~SIMULATION~~: PRELIMINARY SYSTEMS
SIMULATOR STUDY
ENGINEERING DESIGN**

(Project 5839-01P01)

International Laser Systems, Inc.
3404 N. Orange Blossom Trail
Orlando, FL 32804

DDC
RECEIVED
JAN 17 1977
A -

**COPY AVAILABLE TO DDC DOES NOT
PERMIT FULLY LEGIBLE PRODUCTION**

Prepared for

PROJECT MANAGER FOR TRAINING DEVICES
Orlando, FL 32813
December 1976

DISTRIBUTION STATEMENT A
Approved for public release;
Distribution Unlimited

Study Period 3 June 1976 - 30 December 1976

Copy available to DDC does not
permit fully legible reproduction

DISCLAIMER

This study was conducted under PM TRADE RDTE Program. Neither the Department of the Army nor any person acting on behalf of the United States Government assumes any liability resulting from the use of the information contained in this document, or warrants that such use will be free from privately owned rights.

Unclassified

SECURITY CLASSIFICATION OF THIS PAGE (When Data Entered)

| REPORT DOCUMENTATION PAGE | | READ INSTRUCTIONS BEFORE COMPLETING FORM |
|---|--|--|
| 1. REPORT NUMBER 18 TND-TR-76-0002-Vol-2 ✓ | 2. GOVT ACCESSION NO. | 3. RECIPIENT'S CATALOG NUMBER 9 |
| 4. TITLE (and Subtitle) Vol I - Indirect/Area Fire Weapons Effect Simulator Study (Summary) Volume II Vol II - Preliminary Systems Engineering Design | 5. TYPE OF REPORT & PERIOD COVERED 10 pto Final 3 Jun-30 Dec 76 | 6. PERFORMING ORG. REPORT NUMBER |
| 7. AUTHOR(s) 10 Robert E. Odom Chairman, Study Advisory Group | 8. CONTRACT OR GRANT NUMBER(s) 15 N61339-76-C-0070 ✓ | |
| 9. PERFORMING ORGANIZATION NAME AND ADDRESS PM TRADE Field Office ATTN: DRCPM-TND-FO Ft Eustis, VA 23604 | 10. PROGRAM ELEMENT, PROJECT, TASK AREA & WORK UNIT NUMBERS 16 1X762727A230 | |
| 11. CONTROLLING OFFICE NAME AND ADDRESS PM TRADE Field Office ATTN: DRCPM-TND-FO Ft Eustis, VA 23604 | 12. REPORT DATE 11 1 Jan 77 12 363p | |
| 14. MONITORING AGENCY NAME & ADDRESS (if different from Controlling Office) | 13. NUMBER OF PAGES Vol I - 83; Vol II - 370 | 15. SECURITY CLASS. (of this report) Unclassified |
| 16. DISTRIBUTION STATEMENT (of this Report) Approved for public release; distribution is unlimited. | | |
| 17. DISTRIBUTION STATEMENT (of the abstract entered in Block 20, if different from Report) | | |
| 18. SUPPLEMENTARY NOTES | | |
| 19. KEY WORDS (Continue on reverse side if necessary and identify by block number) Training Devices Electronics Simulation Position Location Lasers Weapons Effects Optics | | |
| 20. ABSTRACT (Continue on reverse side if necessary and identify by block number) This report presents the results of an exploratory development study designed to investigate feasible alternatives for the simulation of indirect fire weapon systems. The study treats several alternative approaches and provides technical assessment costs and schedule for development. A Preliminary Systems Engineering Design, PSED, of the recommended approach is presented. | | |

TABLE OF CONTENTS

| <u>Appendix</u> | <u>Title</u> | <u>Page</u> |
|-----------------|--|-------------|
| A | USE OF THE ATMOSPHERIC ELECTRIC FIELD FOR THE DERIVATION OF VULNERABILITY WEIGHTING FACTORS IN THE PRESENCE OF INDIRECT FIRE | A-1 |
| B | RELATIVE VALUES OF COMPETING SYSTEMS | B-1 |
| C | LASER WEAPON SIMULATOR - AREA KILL | C-1 |
| D | VHF TRILATERATION GROUND DESIGNATION SYSTEM | D-1 |
| E | VISUAL CUEING | E-1 |
| F | SHELL SMOKE | F-1 |
| G | LASER WEAPON SIMULATOR - POINT KILL (LWS-P) | G-1 |
| H | SIMULATION SYSTEM FIELD COMMUNICATIONS | H-1 |
| I. | SYSTEMS LOGISTICS - LASER WEAPON SIMULATOR SYSTEM | I-1 |
| J | LOW COST INDIRECT-FIRE SIMULATION LOCATION SUBSYSTEM | J-1 |
| K | SYSTEM "X" | K-1 |
| L | POSITION FINDING SYSTEMS | L-1 |
| M | HIGH RISK AREAS | M-1 |
| N | TARGET DECODER/P _k ANALYZER | N-1 |
| O | SYSTEMS COSTS | O-1 |

| | | |
|---------------------------------|-----------------------|-------------------------------------|
| RTIS | White Section | <input checked="" type="checkbox"/> |
| BCC | Ball Section | <input type="checkbox"/> |
| ORARHOINGOM | | <input type="checkbox"/> |
| JUSTIFICATION | | |
| BY | | |
| DISTRIBUTION/AVAILABILITY CODES | | |
| Dist. | AVAIL. and or SPECIAL | |
| A | | |

APPENDIX A

USE OF THE ATMOSPHERIC ELECTRIC FIELD
FOR THE DERIVATION OF VULNERABILITY WEIGHTING FACTORS
IN THE PRESENCE OF INDIRECT FIRE

Prepared by
Graham W. Flint

September 1976

Table of Contents

- I Introduction and Summary
 - II Basic properties of the atmospheric field
 - A. Fair weather conditions
 - B. Variations in field strength
 - 1. Long term fluctuations
 - 2. Short term fluctuations
 - 3. Prospects for compensation
 - III Fields in the vicinity of orographic protrusions
 - A. Large topographic features
 - B. Small topographic features
 - C. Man sized objects
 - IV Measurement of the atmospheric field
 - A. Characteristics of ionized current sources
 - B. Potential probes
 - V Preliminary system design
 - A. Probe design
 - B. Electronic design
- References

**COPY AVAILABLE TO DDC DOES NOT
PERMIT FULLY LEGIBLE PRODUCTION**

List of Figures

1. World wide diurnal variation of electric field and thunderstorm activity
2. Topographic contour and associated electric field strength for typical mountain in the eastern U.S.
3. Potential contours surrounding a wall having a height of 3 meters
4. Field augmentation as a function of protrusion geometry
5. Influence of ventilation on the space charge and electric field in the vicinity of an ionizing collector
6. Equipotentials and electric fields around a cylindrically symmetric probe
7. Equipotentials and electric fields around a non-symmetric probe
8. Mechanical schematic of helmet mounted sensor
9. Block diagram and circuit of electrometer system

DISTRIBUTION STATEMENT A
Approved for public release;
Distribution Unlimited

I INTRODUCTION AND SUMMARY

It has been proposed that the local intensity of the atmospheric electric field could be used as a measure of the vulnerability of an individual to the effects of indirect fire. Such a technique would be based upon the fact that the atmospheric electric field varies according to the degree of electrostatic shielding provided by buildings, walls, vehicles etc. For example, if a soldier stands in open terrain, his helmet becomes the extremity of an orographic protrusion; the electric field strength at the apex being greatly intensified. Conversely, if the wearer is overshadowed by a conductive object, such as a building or large vehicle, his helmet is now in the "shelter" of a larger orographic protrusion. Thus, the field strength is reduced. For extreme cases, such as when the wearer is within a building or at the bottom of a foxhole, the field strength falls to a very low value.

From the above, it is apparent that the output of a helmet mounted field sensor will bear some relationship to the extent to which the wearer is exposed to the outside world. In the presence of indirect fire, therefore, one can anticipate a reasonable statistical relationship between sensor output and the probability that the wearer will be either wounded or killed.

It is the purpose of this report to examine the characteristics of helmet mounted sensors, and to assess their effectiveness as a means whereby realistic individual kill probabilities can be established. The body of the report is divided into four principal sections, numbered II through V. These sections cover the basic properties of the atmospheric field, fields in the vicinity of orographic protrusions, measurement of the atmospheric field, and preliminary system design.

In the discussion of basic properties of the atmospheric field it is shown that the so called "fair weather field" prevails for about 90% of the time. Causes of fluctuations in the fair weather field can be grouped according to the size of the areas over which their effects are likely to be reasonably uniform. On a global scale there are annual fluctuations of about $\pm 15\%$ combined with diurnal fluctuations on the order of $\pm 20\%$. Over areas in the 1 - 10 km range there are local two cycle per day fluctuations associated with the turbulence cycle, together with the motion of large cloud masses. In the range of 100 - 1,000 meters there are

variations due to the drift of low altitude clouds of space charge. The collective effect of these fluctuations is such that a non-compensated field sensor would experience anomalies in excess of $\pm 30\%$ for perhaps 10% of the time during fair weather. By compensation via a fixed field reference sensor, such anomalies would be reduced to an RMS value of less than 10 percent of the mean field. During 5 - 10 percent of the time, when fair weather conditions do not prevail, fluctuations and reversals of the field are such that vulnerability assessment would become unreliable.

The discussions presented in Section III deal with three classes of orographic protrusion; these being large topographic features, small topographic features, and man sized objects. As an example of a large feature, the field strength on a typical mountain ridge is shown to be about 75% greater than that for level terrain. In the class of small topographic features, an analysis is presented of the fields which surround a three meter wall. It is shown that, relative to an upright man in level terrain, the field strength at distances of 6 meters and 1.2 meters from the wall are 0.6 and 0.6 respectively. Similarly, for a crouching or kneeling man at distances of 6 meters and 0.3 meters, the field strengths are about 0.3 and 0.1 respectively. The analysis of isolated man sized objects indicates that, for an individual protected by a foxhole or small trench, the relative field strength is reduced to the range 0.03 to 0.12; the extent of the reduction depending upon the degree to which the individual's helmet protrudes above the ground plane.

The techniques by which the atmospheric field can be measured are dealt with in Section IV. Here, the use of a radioactive collector is examined for two modes of operation; namely the current amplifier mode and the potential equalizer mode. It is shown that, for the current mode, the influence of fluctuations in local wind velocity are such as to cause prohibitive noise. The higher impedance potential equalizer mode can overcome this problem. However, for minimum noise, it is important that the collecting probe be designed with electrostatic mirror symmetry about a plane which is perpendicular to the field and which passes through the center of the collector.

The discussion of preliminary system design deals both with sensor probe design and with the design of associated electronics. A design is presented for a compact and rugged probe which meets

all of the requirements derived in the preceding sections of the report. Incorporated in the design is an annular radioactive collector with adjacent guard rings for control of leakage conductance. It is shown that minimization of this conductance in the presence of accumulated dirt on the exterior surfaces of the probe represents a critical feature of both mechanical and electronic design. Two alternate circuits employing insulated gate field effect transistors in the input stages are discussed. Both circuits include high voltage feedback drivers, whereby the potential difference between the collector and its guard rings is kept small. Finally, with respect to the possible use of electronic field strength compensation via a fixed field monitoring station, it is suggested that such a correction might be included in the designation code employed by the indirect fire simulator.

DISTRIBUTION STATEMENT A
Approved for public release
Distribution Unlimited

II BASIC PROPERTIES OF THE ATMOSPHERIC FIELD

To establish the feasibility of using atmospheric electric field measurements for the assessment of personnel vulnerability it is necessary to examine the fundamental characteristics of such fields. The magnitude of the field, together with the effective impedance of the atmosphere determines the required sensitivity and input impedance of the measuring device. Similarly, a realistic transfer function, whereby variations in local field strength are related to different degrees of vulnerability, must be derived from an examination of the dependence of the field upon orographic protrusions. To assess the statistical accuracy of such a system it is necessary to establish the magnitude of both short term and long term fluctuations in the field. It is appropriate, therefore, that the subsequent discussions of measurement techniques and system design should be prefaced by a description of the basic properties of the atmospheric electric field. For this purpose we shall begin by developing an approximate model for the so called "fair weather field". This will be followed by an examination of the magnitude and frequency of occurrence for fluctuations in the field.

A. Fair weather conditions

In the context of this report it is not necessary to employ a very sophisticated model of the conductive processes in the atmosphere. We are not interested, for instance, in the detailed mass distribution of current carrying ions. It is sufficient merely to set bounds upon the ion density and upon the effective ion mobility. Also, we are interested only in the field close to the earth's surface. The reader requiring more detailed information should refer to the analyses conducted by Chalmers¹, Israel² and Dolezalek³.

In addition to the simplified nature of the model, the ensuing discussions of atmospheric properties will, for the most part, be confined to the conditions identified generally as "fair weather". In this context the term "fair weather" refers to those occasions when the electric field vector is directed toward the earth and when there is no precipitation or electrical storm activity in the area. There is a high degree of correlation between the meteorological and the electric field definitions of fair weather. However, as will be noted in the subsequent discussion

of short term fluctuations, the field can occasionally reverse during meteorologically fair weather. Over the Continental United States fair weather electric field conditions can be anticipated for at least 90% of the time⁵.

At an altitude of about 50 km the conductivity of the atmosphere is sufficiently high to prevent any appreciable potential gradients. This conductive region is generally referred to as the electrosphere. Thus, in its simplest form, the atmospheric electric field can be regarded as that which exists between the electrodes of a concentric shell spherical capacitor wherein the inner and outer shells are represented by the earth's surface and the electrosphere respectively. The potential of the electrosphere is approximately 350 Kv positive with respect to the earth's surface. However, since the finite conductivity of the atmosphere increases with altitude, this potential difference is far from uniformly distributed. At the earth's surface the field is usually greater than 100 V/m; falling rapidly to less than 10 V/m within the first 10 km.

The conductivity of the upper atmosphere is dominated by ions which are formed by cosmic rays. Over land the rate of ionization up to an altitude of about 1 km is governed by surface radioactivity. Over the oceans cosmic ray ionization predominates at all altitudes. Either source of radiation results in the formation of electron/ion pairs. In the lower atmosphere electrons are quickly attached to neutral molecules; thereby producing negative ions. Both the negative and the positive ions so produced are more complex than single charged molecules of oxygen and nitrogen. The ions which provide the principal contribution to atmospheric conductivity are called "small" ions and are believed to consist of from four to ten molecules bound in a cluster by the polarization forces exerted by the initially single charged simple molecule⁴. Larger ions, formed when small ions attach to aerosols or dust particles, have relatively low mobilities and contribute significantly only to the net space charge. The mobilities of small ions fall typically within the range 10^{-4} - 2×10^{-4} m²/V-s. In our later discussions of sensor design, where the local atmospheric field is augmented by a conductive protrusion, we shall encounter fields in the range 1000 - 5000 V/m. Thus, in considerations of ion drift in the neighbourhood of sensors, the mean velocities of interest will fall in the range of 10 to 100 centimeters per second. The typical concentration of small positive ions in the vicinity of the ground

varies from 200 to 600 per cubic centimeter. The ratio of small positive ions to small negative ions falls in the range 1.1 to 1.5.

In fair weather regions the electric current between the earth's surface and the electrosphere is carried by the combined effect of downward moving positive ions and upward moving negative ions. Measurements conducted by Kraakevik and Clark⁶ indicate that the current density is essentially independent of altitude throughout the lower portion of the atmosphere. The value of this current density lies typically within the range 10^{-12} to 4×10^{-12} A/m².

For a median current density of 2×10^{-12} A/m² and a nominal electrosphere potential of 350 kv the total resistance of a vertical column of atmosphere having a cross section of one square meter becomes 1.75×10^{17} ohms. The major portion of this total resistance lies in the lower atmosphere; the typical resistance of such a column close to the earth's surface being on the order of 5×10^{13} ohm/m.

The above resistance, combined with a current density of 2×10^{-12} A/m, yields a typical field of 100 V/m near the surface. Since the surface charge density, σ , is given by $\sigma = -\epsilon_0 E$, the charge density on the surface of the earth is on the order of 10^{-9} coulomb/m². At the stated current density the period required to neutralize such a charge would be on the order of 500 seconds.

The most widely accepted model which accounts for the maintenance of the atmospheric space charge assumes that the charge is resupplied by thunderstorm activity. The average number of thunderstorms which are active at any time over the entire surface of the earth is approximately 1800. Statistical evidence indicates that, on average, an active thunderstorm will provide a current on the order of 1 amp. A current of 1800 amps averaged over the surface of the earth would provide a current density of 3.5×10^{-12} amp/m². Such a figure is in fair agreement with the measured value.

At any specific instant in time the world wide thunderstorm activity may vary significantly from the average value. Since the time constant of the atmospheric charge is only a few minutes, such variations will be of importance in establishing the field measurement criteria employed for vulnerability sensing. As will be shown in Subsection IID, these fluctuations exhibit both diurnal and random components.

If we define the atmospheric conductivity as γ mho/m, then we can write

$$\vec{E} = \vec{J} / \gamma \quad (\text{volt/m}) \quad (1)$$

where \vec{E} is the field and \vec{J} is the altitude independent current density in amps per square meter. Thus, for regions close to a level surface, the electric field is approximately proportional to the local atmospheric resistivity.

As noted previously, the electric field decreases substantially with increasing altitude; i.e. $\partial E / \partial z \neq 0$. Thus, the net charge density, ρ , given by

$$\rho = \epsilon_0 (\nabla \cdot \vec{E}) \quad (2)$$

must also be non-zero. For normal fair weather conditions the lower atmosphere carries a net positive charge. From measurements made by Gish⁷ the magnitude of this excess positive charge would seem to be on the order of 10^{-12} coulomb/m³.

Using the above units for charge density, the rate at which the electric field decreases with altitude can be approximated by:

$$\frac{dE}{dz} = - \frac{d^2 V}{dz^2} = 1.14 \times 10^4 e \quad (V-m^{-2}) \quad (3)$$

From the above it becomes apparent that the reduction in field with altitude can be ignored when calculating the field augmentation due to small objects such as personnel, vehicles or low buildings. However the reduction must be taken into account when computing the augmentation due to modest hills or tall buildings.

B. Variations in Field Strength

Major fluctuations in the atmospheric electric field must be taken into account in the design of any sensor which responds to the magnitude of the field. Not only are field reversals observed during thunderstorm activity, but wide variations occur in the fair weather field. Such variations exhibit a wide range of time scales. Superimposed upon annual and daily variations are fluctuations having periods ranging from hours to seconds. These latter fluctuations are essentially random in nature.

In the context of vulnerability sensors, the fluctuations in electric field can be divided into three classes. First there are the long term variations which can be predicted with a fair degree

of accuracy. Compensation for this class could be achieved in a relatively straightforward manner. The second class includes fluctuations which cannot be predicted far in advance of their occurrence, but which extend over a large area. Such fluctuations might be detected by a master fixed sensor from which a real time correction factor could be derived. Finally, there will be the truly random fluctuations which exhibit neither temporal nor spatial correlation between sensors which are separated by distances on the order of a hundred meters or more. It is unlikely that any effective compensation could be provided for this type of fluctuation.

To provide a simple model for the principal factors which cause field variations it is convenient to begin with an equation which describes the field at a point:

$$E = J R \quad (4)$$

Here, J is the current density and R is the resistivity at the point of measurement.

If, for a column extending between the earth's surface and the electrosphere the total potential difference is V_T and the total resistance is R_T , then we can write:

$$E = \frac{V_T R}{R_T} \quad (V/m) \quad (5)$$

If we differentiate with respect to time and divide by equation (5) we obtain:

$$\frac{1}{E} \frac{dE}{dt} = \frac{1}{V_T} \frac{dV_T}{dt} + \frac{1}{R} \frac{dR}{dt} - \frac{1}{R_T} \frac{dR_T}{dt} \quad (6)$$

As will be shown, the correlation between thunderstorm activity and potential gradient is good. Thus, in equation (6) the first term, which describes variations in electrosphere potential, includes both annual and diurnal fluctuations in the field. However, this term is dominant only over the oceans, the polar regions, and isolated continental regions. For most industrialized areas there are effects due to atmospheric pollution which correlate with local time. Such effects are caused by low altitude variations in the resistivity and can be assigned to the second term in equation (6). The third term is associated with changes in the total columnar resistance, and can be significant in the vicinity of clouds having large vertical and horizontal extent.

In addition to the low frequency fluctuations described by equation (6) there are fluctuations having periods of a few tens

COPY AVAILABLE TO DDC DOES NOT PERMIT FULLY LEGIBLE PRODUCTION

of seconds to a few minutes. These have been shown^{8,9,10} to be associated with drifting clouds of space charge; the drift velocity being closely correlated with local wind velocity.

Following this brief qualitative discussion we shall now examine both long and short term fluctuations in a quantitative fashion.

1. Long term fluctuations

On a worldwide basis the atmospheric field exhibits two distinct fluctuation periods; namely annual and diurnal. The annual fluctuation represents a single cycle which provides a maximum field in January and a minimum in July. The amplitude of the annual cycle is approximately $\pm 15\%$ of the mean.

As noted previously, correlation between the world wide diurnal thunderstorm activity and the daily cycle in the atmospheric field is good. Data presented by Whipple and Scrase¹¹, which is reproduced in Figure 1, illustrates the extent to which these functions track in both amplitude and phase. Figure 1a gives the global diurnal variation of the atmospheric field as derived from Arctic and oceanic measurements. Figure 1b shows the corresponding diurnal variation of thunderstorm expectation for individual continental areas and for the collective land area of the globe. In both figures the time scale is based upon Greenwich Mean Time. From Figure 1a it is apparent that the diurnal fluctuation is slightly less than $\pm 20\%$.

It should be noted, however, that the data of Whipple and Scrase is based upon yearly averages. Thus, superimposed upon these data one would expect to encounter statistical fluctuations. For instance, if we assume that the world wide average number of 1300 thunderstorms represents the mean value of a normal distribution, then the standard deviation becomes 42 storms, or about $2\frac{1}{2}\%$. However, it is likely that non-random, but poorly understood, influences will yield a somewhat larger standard deviation.

2. Short term fluctuations

Over a large fraction of the world's land area, particularly in industrialized areas, the fluctuations in atmospheric field are far more complex than those encountered over the oceans. In many cases there exists a two cycle per day variation which is synchronized with local time. Such behaviour is usually caused by

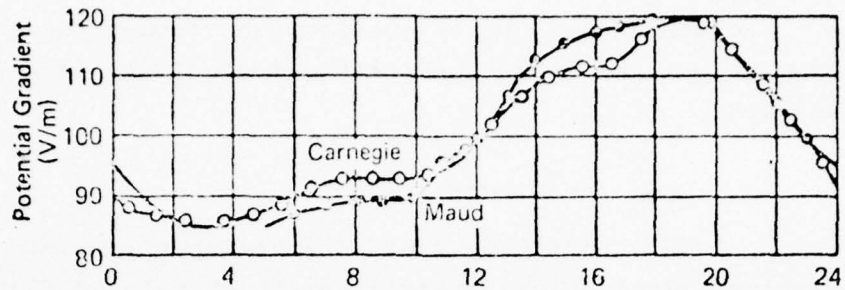

(a) Global diurnal variation of atmospheric potential gradient from Arctic and oceanic measurements

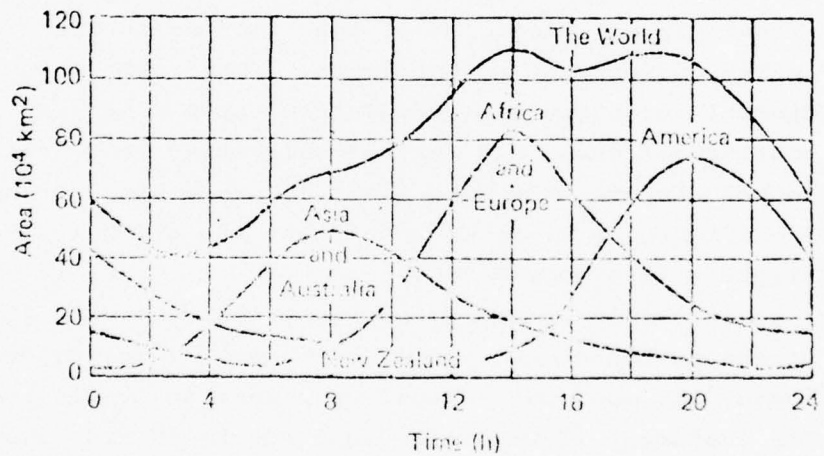

(b) Global diurnal variation of thunderstorm expectation for individual continents and (envelope curve) for the global continent. Area covered at any time by thunderstorms is plotted in 10^4 km^2 and classified according to GMT.

Figure 1
World wide diurnal variation of electric field and thunderstorm activity

drifting atmospheric pollution. The presence of pollution tends to increase the local resistivity; thereby influencing the local field via the second term in equation (6). Close to industrial areas these local fluctuations are typically larger than the world wide annual and diurnal cycles. For instance, in the London area the mean low altitude resistivity is six times the global average.

As the distance from an industrial zone is increased, so the magnitude of the pollution induced daily cycle decreases. Over land areas which are remote from habitation and industry, the conductivity executes a relatively simple daily oscillation with a maximum value near dawn and a minimum value in mid-afternoon. The oscillation is controlled by the concentration of particulate matter suspended in the atmosphere and by the concentration of radioactive gases. These, in turn, are affected by the local daily cycle of turbulence. In these more remote areas the field fluctuations induced by the local conductivity effects appear superimposed upon the world wide annual and diurnal cycles.

As noted earlier, the presence of extensive cloud can influence the total columnar resistance. If such clouds carry a space charge, this also will affect the low altitude field. However, using ground based measurements alone it would be difficult to differentiate between the two effects. Stringfellow⁹ has measured the surface field beneath drifting clouds. Using observation sites separated by 5 - 7 km, he observed temporal correlation times ranging from about 2 to 20 minutes. Typical spatial correlation distances were on the order of 10 km. Presumably the actual times and distances for any specific situation would depend upon size, altitude and drift velocity of the cloud. However, it would seem that this effect will always provide fluctuations at relatively low frequencies and which extend over areas of a kilometer or more. Thus, individual sensor compensation via a nearby calibration sensor should be feasible.

A more troublesome source of local fluctuations lies in the presence of low altitude clouds of space charge which drift with the wind. Measurements of the power spectrum and correlation distance have been conducted by several workers^{8,10,12,13}. Measurements undertaken in England by Large, using probes at an elevation of 7 meters, indicate that the typical amplitude of such fluctuations is about 10 V/m; the average period being 40 seconds.

Similar measurements made by Yerg and Johnson at an elevation of 1 meter above an airfield in Michigan yielded a mean standard deviation of 10 V/m together with a standard deviation spread of 6 - 19 V/m. The mean correlation time and mean correlation distance for the Michigan measurements was 62 seconds and 204 m, respectively. The extreme spread in correlation time was 33 - 117 seconds. The extreme spread in the correlation distance was estimated to be 135 - 427 m.

In addition to the fluctuations discussed above there are, even in fair weather, occasional extreme excursions in the field; some of sufficient magnitude to cause a field reversal. Measurements conducted by Loeffel and Mill¹⁴ which extended over a period of nineteen days showed four periods of field reversals; two of which coincided with periods of precipitation. Analysis of their data indicates that when field reversals occur they persist for less than 10% of the total time. Recordings made over a two year period at Pensacola, Florida¹⁴ indicated field reversals for less than 5% of the time. Similar recordings made at Norfolk, Virginia yielded reversals for 15% of the time in 1959 and 5.7% of the time in 1960.

3. Prospects for compensation

Summarizing the preceding discussions, and, for the moment, ignoring conditions of field reversal, we can group the fluctuation mechanisms according to the size of the areas over which their effects are likely to be reasonably uniform. On a global scale we have the annual $\pm 15\%$ fluctuation combined with the diurnal $\pm 20\%$ fluctuation. Over areas in the 1 - 10 km range we can include the local two cycle fluctuation induced by pollution, the local single cycle fluctuation associated with the turbulence cycle, and the notion of large cloud masses. In the range of 100 - 1,000 m we must consider the drift of low altitude clouds of space charge.

For most continental areas the global scale fluctuations are largely swamped by local effects. Thus, sensor compensation for these fluctuation components alone would achieve little. Their combined amplitude of $\pm 35\%$, however, should be taken into consideration when establishing the dynamic range of sensor electronics.

For areas in the intermediate range the largest factor at most continental sites will be the severe fluctuation in resistivity due to low altitude pollution. The magnitude of these fluctuations can

be very great; perhaps as large as 10:1. However, since both the correlation distances and periods are likely to be large, a fixed local field monitor should provide the information necessary for either continuous or periodic compensation of individual sensors.

In the range of small areas one can anticipate an average field fluctuation of about 10 V/m RMS due to space charge drift. However, in view of the statistical purpose of the vulnerability sensor, and the large ratio of maximum to minimum vulnerability signals, it is unlikely that a noise signal of this magnitude will prove troublesome. Further, since large fluctuations tend to be associated with the larger correlation distances, any form of compensation employed for the fluctuations associated with pollution phenomena will tend also to reduce the effective amplitude of noise induced by space charge drift.

As an alternative to the continuous or periodic compensation via a local field monitor, it might prove satisfactory to accept a degree of error on a statistical basis. For instance, the fair weather field measurements made by Yerg and Johnson¹⁰ at Houghton, Michigan exhibited a 90% probability of fields between the limits of 100 V/m and 174 V/m. Thus, for their particular location, it would seem that the field for 90% of the time could be defined as 137 V/m with an accuracy of $\pm 27\%$. Since we are concerned with vulnerability ratios of perhaps ten to one and greater, perhaps an essentially random error on the order of 30% is acceptable. Certainly, statistical data on field strength should be gathered from the areas in which the proposed system is to be deployed. If such data were to establish that the errors associated with uncompensated sensors are acceptable, then the system would be greatly simplified.

Finally, turning to the problem of field reversals, it seems likely that any system of vulnerability sensing would become unreliable during periods of intermittent field reversal. Under such disturbed field conditions a fixed local field monitor could be employed to disable the vulnerability sensing function of individual sensors. Thus, for perhaps 5 - 10 percent of the time the vulnerability factor would be forced to revert to a fixed probability.

III FIELDS IN THE VICINITY OF OROGRAPHIC PROTRUSIONS

From the simplest consideration of the atmospheric field in the presence of non-flat terrain it is evident that there will be a degree of correlation between the local field strength and the degree of exposure. The field on the summit of a hill will be greater than that in a neighbouring valley. Similarly the field measured in the shelter of a wall or vehicle will be less than that above nearby open ground.

To establish design criteria for a realistic vulnerability sensor it is necessary to develop a quantitative model for the atmospheric field in the presence of various topographic features. Toward this end we shall begin by deriving a general expression for the potential in the vicinity of an orographic protrusion. This will be followed by a discussion of computer solutions for the field in the presence of both large and small terrain features. Finally, we will examine the field augmentation which occurs in the vicinity of a helmet mounted sensor probe when the wearer assumes various postures.

In the derivation of a basic expression for the atmospheric potential it is convenient to follow the approach of Leffel and Hill⁵. For this purpose we shall rewrite equation (2) in the form:

$$\nabla^2 u = -\frac{\rho}{\epsilon_0} \quad (7)$$

which is Poisson's equation for the potential, u , in terms of the charge density, ρ , and the dielectric constant, ϵ_0 .

The divergence of the current density within the atmosphere is assumed conventionally to be zero. Thus:

$$\nabla \cdot \vec{J} = 0 \quad (8)$$

Substituting for \vec{J} from equation (1) yields:

$$\nabla \cdot (\gamma \vec{E}) = \vec{E} \cdot \nabla \gamma + \gamma \nabla \cdot \vec{E} = 0 \quad (9)$$

which is more conveniently written in the form:

$$\nabla \cdot \vec{E} + \vec{E} \cdot \frac{\nabla \gamma}{\gamma} = 0 \quad (10)$$

If we now assume that the conductivity, γ , varies only with elevation, z , then we can write:

$$\vec{E} \cdot \frac{\nabla \gamma}{\gamma} = E_z \frac{\partial \gamma / \partial z}{\gamma} = E_z \frac{\partial (\ln \gamma)}{\partial z} \quad (11)$$

Substituting from equation (11) in equation (10) we obtain:

$$\nabla \cdot \vec{E} + E_3 \frac{\partial (\ln \gamma)}{\partial z} = 0 \quad (12)$$

Writing equation (12) in terms of the potential, U , now yields

$$\nabla^2 U + \frac{\partial (\ln \gamma)}{\partial z} \frac{\partial U}{\partial z} = 0 \quad (13)$$

Since, over limited ranges, the variation of conductivity with altitude can be approximated closely by an exponential function, we have:

$$\gamma = \gamma_0 e^{\beta z} \quad (14)$$

or, alternatively:

$$\frac{\partial (\ln \gamma)}{\partial z} = \beta \quad (15)$$

Finally, by substitution of equation (15) in equation (13) we obtain:

$$\nabla^2 U + \beta \frac{\partial U}{\partial z} = 0 \quad (16)$$

Several idealized computer solutions have been obtained for equations (13) and (16). Kwang Yu¹⁵ has derived an analytic solution of equation (13) when applied to the contours of typical mountains in the eastern U.S. Two dimensional solutions of equation (16) have been obtained by Loppel¹⁶ for a triangular mountain and a cliff. At Johns Hopkins University⁵ computations employing equation (16) have been performed for a wall, a wire fence, and an upright pole. The ensuing discussions of large and small topographic features are based upon the results of these computer studies.

A. Large Topographic Features

The specific mountain ridge employed by Kwang Yu in his two dimensional computations was a section of South Mountain north of Harper's Ferry. This example was chosen for two reasons. First, its contour is typical of mountains in the eastern U.S.. Second, its actual contour can be approximated closely by a convenient

boundary condition expression. The contour employed in the analysis appears as the lower curve in Figure 2. The computation of electric field was based upon a ground level field of 100 V/m at an infinite distance from the mountain. The ground level conductivity, γ_0 , and the exponent, β , were given arbitrary values of 4.55×10^{-14} (mho/m) and 2.22×10^{-4} (m^{-1}) respectively. The surface is assumed to be a perfectly conducting boundary plane.

Bearing in mind the anticipated magnitude of fluctuations in the field, it is probably impractical to detect the 6 to 7 V/m reduction in field strength associated with the concave approach to the mountain. However, the vulnerability in such a location should not be much different from that on level ground. On the other hand it would not be difficult to register the greatly increased field within 100 m of the crest. Thus, in the region where vulnerability is enhanced by the risk of silhouetting, an individual sensor system should be capable of providing a modified kill probability weighting factor.

B. Small Topographic Features

Individual vulnerability is reduced by the protection of buildings walls or vehicles. The field within a conductive sheath is zero. Thus, the output from a sensor located within a building or an armoured vehicle must be zero. To establish appropriate vulnerability weighting factors, therefore, we must equate zero field with the protection afforded by enclosure within a building or vehicle. Intermediate levels of protection are provided by the shelter of walls etc. For instance, in an indirect fire situation, the close proximity of a substantial wall should reduce the vulnerability to shrapnel by about 50%. It is of interest to determine the extent to which the field is reduced in such a location.

The analytic work at Johns Hopkins University⁵ has provided potential contours for a wall having a height of 15 meters and a thickness of 2 meters. Since we are interested in walls of a more modest height these data have been scaled down to those which correspond to a wall which is 3 meters high and 0.3 meters thick. Such scaling is quite valid for low protrusions since the change of conductivity with altitude ($\beta = 2.22 \times 10^{-4} m^{-1}$) can be neglected.

COPY AVAILABLE TO DDC DOES NOT PERMIT FULLY LEGIBLE PRODUCTION

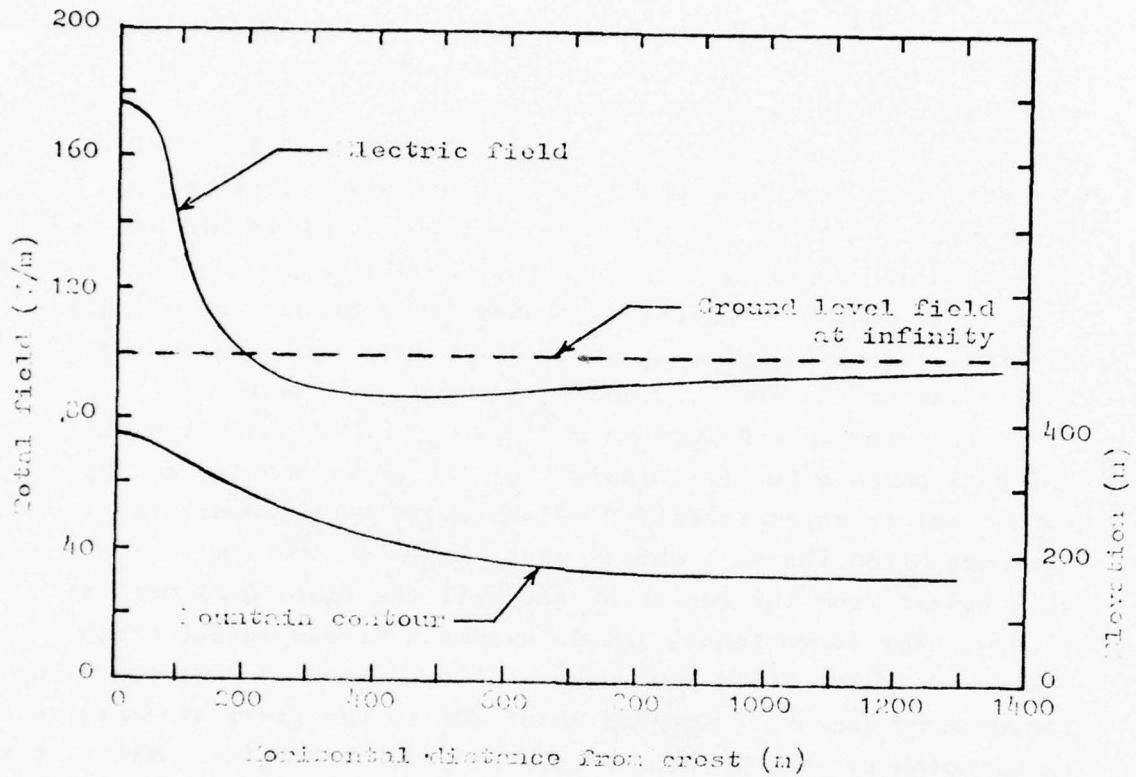

Figure 2
Topographic contour and associated
electric field strength for typical
mountain in the eastern U.S.

Thus, for the same field strength, the vertical and horizontal potential gradients remain identical provided the ranges and heights at which the field is measured are also divided by a factor of five.

The general form of the scaled potential contours are shown in Figure 3. The ground level field at infinity is taken to be 100 V/m. From the shape of the equipotential planes it is apparent that the field measured by a sensor in the vicinity of the wall must be dependent upon the orientation of the sensor. For a helmet mounted probe and an upright individual, the augmentation effect, which will be discussed in detail later, is such that the field measured is essentially the vertical component of the field. However for a crouching man, the augmentation effect is less pronounced. Also a crouching man is liable to hold his head in a less upright position. Thus, in this latter case, we shall consider a range of field strengths; the lower limit corresponding to the vertical component, and the upper limit corresponding to the vector sum of the vertical and horizontal components.

First let us consider an upright man approaching the wall. For this purpose we will assume that the probe mounted on top of the helmet is approximately 2 meters above the ground. For large distances from the wall the vertical field is 100 V/m. At a range of 6 meters from the center of the wall the field will drop to 79 V/m. For convenience, let us assume a linear relationship between detected field and vulnerability weighting factor. Using a compensated sensor, a drop of about 20% in the field strength should be detectable. Thus, on average, the predicted vulnerability at two scale heights from the wall would be set at about 80% of that for a man standing in open level terrain. At 1.2 meters from the center of the wall the vertical field drops to 60 V/m. Such a figure would seem to be in fair agreement with our first estimate of a 50% vulnerability reduction for positions close to the wall.

For a crouching man we will assume that the sensor height is 1 meter. Again, at large distances from the wall the field will be 100 V/m. At 6 meters range it drops to 80 V/m; i.e. essentially identical to that for a 2 meter elevation at the same range. At 0.8 meters from the center of the wall the horizontal field becomes dominant and, by the earlier definition, the detected field will fall between 19 and 35 V/m. Again, using a linear response, such a measurement would indicate a factor of 3 to 5 reduction in

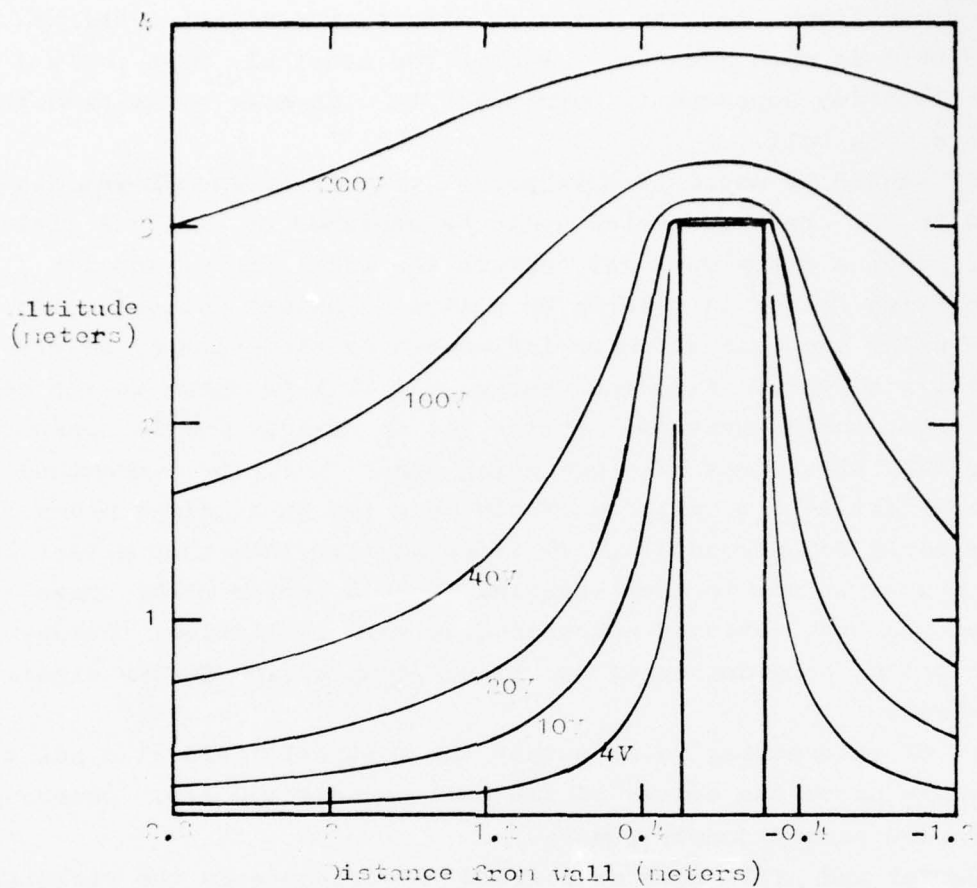

Figure 3
 Potential contours surrounding
 a wall having a height
 of 3 meters

vulnerability with respect to a crouching man in open terrain. The greater reduction in vulnerability compared with that for the upright man stems from two factors. First, the relative height of the wall is much greater. Second, the available data for a 1 meter elevation happened to correspond to a shorter range from the center of the wall.

It should be noted at this point that all of the fields discussed so far are those which would be measured by an ideal field meter. Such a meter does not perturb the local field, and its augmentation factor is said to be unity. A helmet mounted sensor, on the other hand, is strongly influenced by the geometry of its conductive support; i.e. the wearer. As will be shown in the next subsection, the augmentation factor for an upright man is approximately 2.75 times that of a crouching man. Thus, for a crouched position next to the wall, the field measured by a helmet mounted sensor would be between 3 and 14 times smaller than that associated with an upright man in open terrain. Such a factor might prove greater than the ratio of corresponding vulnerabilities; thereby necessitating some degree of non linear compression in the signal processing.

It is interesting to note that the vertical field at a point 0.5 meters above the center of the wall exceeds 250 V/m. Somebody should have warned Dumpty Dumpty.

Leffel and Hill⁵ have made field measurements in the vicinity of walls, fences, and small isolated buildings. In all cases the behaviour of the field was in agreement with prediction. Their data for a steel mesh fence, 3.2 meters high, agrees well with the figures postulated above for a 3 meter high wall.

C. Man sized Objects

The most practical design for an electrostatic vulnerability sensor would seem to take the form of a small probe extending vertically from the wearer's helmet. The probe, therefore, would measure the field at the upper extremity of a conducting protrusion comprised of the helmet and its wearer. The exact nature of the field in the vicinity of a protrusion of such complex shape is extremely difficult to compute. However, if we consider the man and his helmet as falling within the envelope of a prolate hemispheroid with its major axis vertical, we can adjust the ratio of major axis

to minor axis so as to approximate the gross human form. The advantages of such an approximation can be seen by examination of an isolated prolate spheroid in an electric field. If such a spheroid is oriented so that its major axis lies parallel to the electric field, then the field lines are symmetric with respect to a plane which bisects the spheroid and to which the major axis is perpendicular. Since this plane must be an equipotential surface, it can be replaced by a conducting surface; i.e. the conducting surface of the earth. Thus, the electric field at the apex of the prolate hemispheroid can be described by the standard form:

$$E = \frac{2c^3 E_0}{-2b^2c + ab^2 \ln\left(\frac{a+c}{a-c}\right)} \quad (17)$$

where E_0 is the uniform field which would exist if the conducting spheroid were not present, a is the semimajor axis, b is the semiminor axis, and $c = (a^2 - b^2)^{1/2}$.

If we define the augmentation, A , as the ratio E/E_0 , we can write:

$$A = \frac{2c^3}{-2b^2c + ab^2 \ln\left(\frac{a+c}{a-c}\right)} \quad (18)$$

The agreement between theory and experiment using the prolate spheroid approximation is surprisingly good. For instance, Kraakevik and Koppel¹⁷, measuring atmospheric electric fields from a Navy DC-121 aircraft, found experimentally that the augmentation of the field at the wingtips was 32.4. Using the spheroid approximation, where the major axis, $2a$, represents the wing span, and the minor axis, $2b$, is the thickness of the fuselage, one obtains a value of 29.

Since we are interested only in the proportions of the conductive envelope we can express the augmentation in terms of a k -factor where $k = a/b$. By substitution in equation (18) we obtain

$$A = \frac{2(k^2 - 1)^{3/2}}{-2(k^2 - 1)^{1/2} + k \ln\left\{\frac{k + (k^2 - 1)^{1/2}}{k - (k^2 - 1)^{1/2}}\right\}} \quad (19)$$

Figure 4 shows augmentation versus k -factor for k -factors in the range 1 - 10. For an upright man the semimajor and semiminor axes of the spheroid can be taken as 1.75 m and 0.25 m respectively; yielding a k -factor of 7. From Figure 3, this k -factor corresponds to an augmentation of 29.0. Thus, if the non-perturbed field at

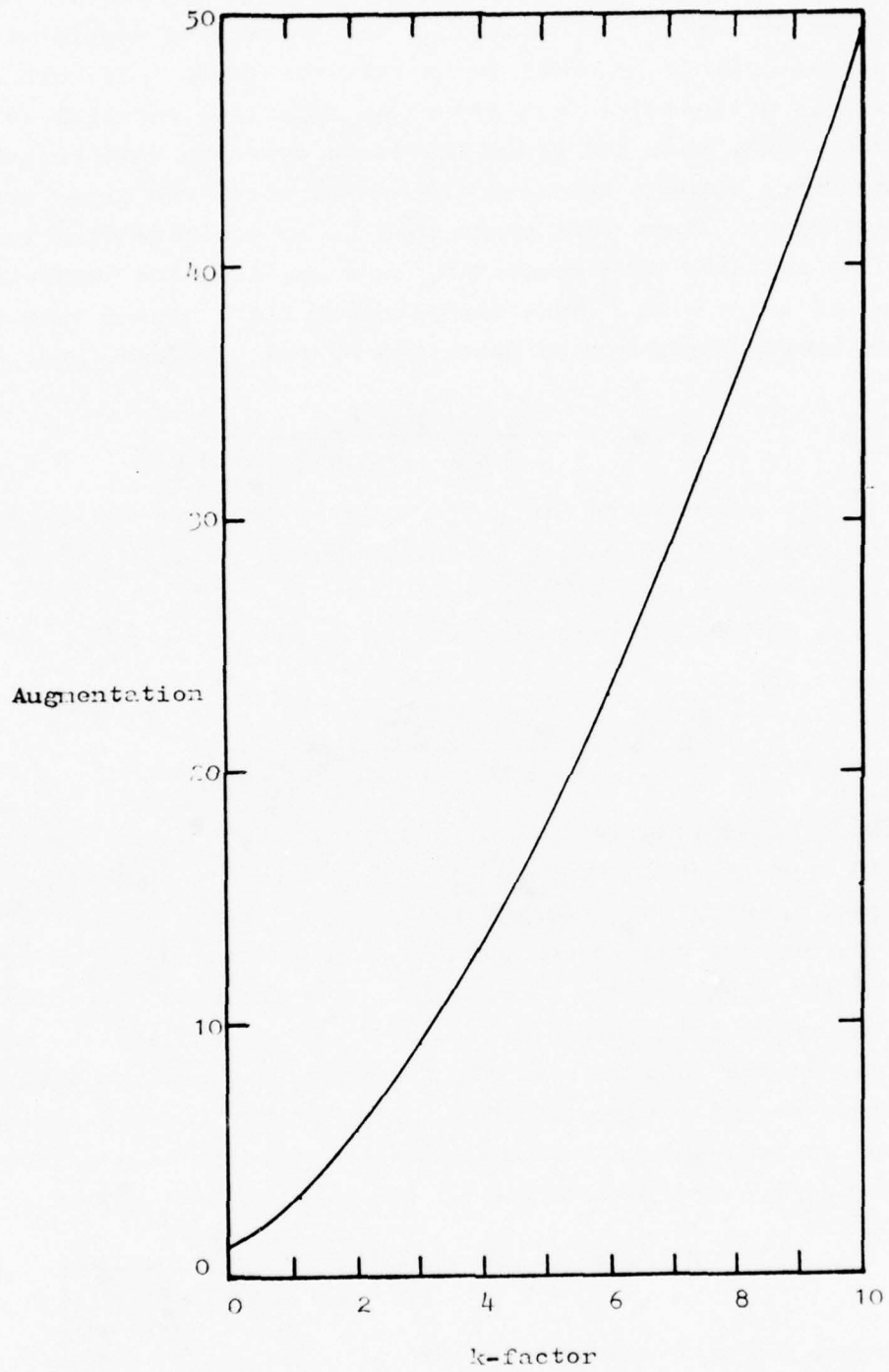

Figure 4
Field augmentation as a
function of protrusion geometry

ground level is 100 V/m, the field at the apex of the helmet for an upright man will be approximately 2,900 V/m. Similarly, for a kneeling or crouching man, where the semimajor and semiminor axes may be taken as 1.0 m and 0.3 m respectively, the field at the apex of the helmet will be approximately 1,050 V/m. Thus, a linear sensor system would indicate that the vulnerability of the upright man is about 2.75 times greater than that of his crouching or kneeling counterpart. It would seem that such a ratio provides fair agreement with the real vulnerability ratio for some types of indirect fire.

As a low vulnerability posture let us consider an individual protected by a foxhole, or narrow trench, such that only his helmet protrudes above the ground plane. The k-factor for such a protrusion is approximately 1.3; giving an augmentation of 3.7. Thus, on a linear scale, this posture would be assigned a vulnerability which is about eight times less than that of an upright man on level terrain. If the man in the foxhole now lowers his head so that the top of his helmet becomes flush with the ground plane, the k-factor will approach zero; giving an augmentation of unity. At this point his vulnerability advantage factor relative to the upright man on level terrain becomes 29 when based upon a linear sensor response.

IV MEASUREMENT OF THE ATMOSPHERIC FIELD

The atmospheric electric field is usually measured either with an electric field mill or with a radioactive probe connected to a high impedance voltmeter. A field mill measures the bound charge upon a conductor which is alternately exposed or shielded by a rotating shutter. The resulting induced current is proportional to the local field. Such instruments have been used extensively^{18,19}, and are quite reliable. However, they are expensive and far too bulky for use in the present application.

Since the advent of high input impedance solid state circuitry, the most convenient and compact method for measuring the atmospheric field has been the radioactive collector. The probe, or collector, in such a system comprises a radioactive source of alpha particles. The ionization induced by the alpha particles produces a localized reduction in the atmospheric impedance; thereby providing a suitable coupling between the atmosphere and a high impedance electrometer. The presence of the ionized zone also serves to enhance the ionic current.

The physical phenomena associated with current amplifying radioactive collectors have been examined by Hill and Heppel²⁰. Their work on the application of radioactive collectors to the stabilization of RPV's has led to an analytical model which satisfactorily accounts for the effects of wind velocity, external electric field, and the strength of the radioactive source. Since the Hill and Hoppel model is directly applicable to the use of radioactive collectors in vulnerability sensors, the ensuing analyses of current and potential probe characteristics will largely follow their approach.

A. Characteristics of Ionized Current Sources

The most satisfactory explanation of current generation by a radioactive source is as follows. The length of the ionized track caused by the passage of an alpha particle through air is a well defined function of initial particle energy and air density; the statistical spread being quite small. The source employed in most radioactive collectors is polonium 210. Since the alpha emission from this material is essentially monoenergetic, the resulting

envelope of ionization which surrounds the source in still air has a well defined boundary. In the presence of an externally imposed electric field, charge separation will occur within the boundary. Ions of one polarity will flow into the circuit connected to the ionizer. Ions of the opposite polarity will flow outward to form a shielding layer of charge which greatly reduces the field within the boundary. The shielding layer is equivalent to the surface charge which forms at the interface between regions of high and low conductivity; thereby creating a discontinuity in the electric field across the boundary. In perfectly still air a small steady-state current will flow between the ionizer and the surrounding atmosphere. In a real atmosphere the current is due primarily to the continuous removal of the shielding charge by natural ventilation. As air motion increases, charge removal becomes more effective; resulting in an increased penetration of the electric field.

The conditions surrounding an ionizing source, with and without ventilation, are shown schematically in Figure 5. Both illustrations have been reproduced directly from a report by Hill and Whyte⁴. Figure 5a illustrates the approximate charge and potential distribution for a collector mounted 1 m above the earth in still air. The conducting path to the earth is assumed to have a resistance on the order of 10^8 ohm, and the external electric field is 100 V/m. These conditions produce a high concentration of negative ions at the outer boundary of the ionized region. For a polonium 210 source the linear dimension of the ionized zone is about 3.0 cm; the size of the zone being exaggerated for clarity in the figure. Field lines associated with the external field terminate on these ions. Thus, the ion sheath acts as an electrostatic shield surrounding the highly conductive air within. The illustrated values of space charge and electric field are typical of those which would appear on the vertical axis of symmetry through the center of the collector. Because of the large space charge at the top of the ionized zone, the field in the vicinity of the collector is reduced to a few percent of the external field. Under the influence of this weak field, positive ions in the vicinity of the collector will drift downward to create a current flow through the load resistor. However, since the field in the region of charge deposition is weak, the resultant current will be small.

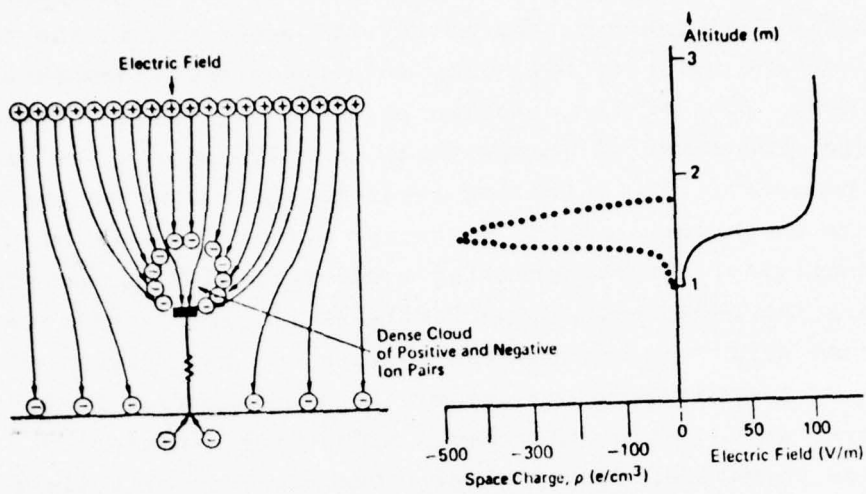

(a)

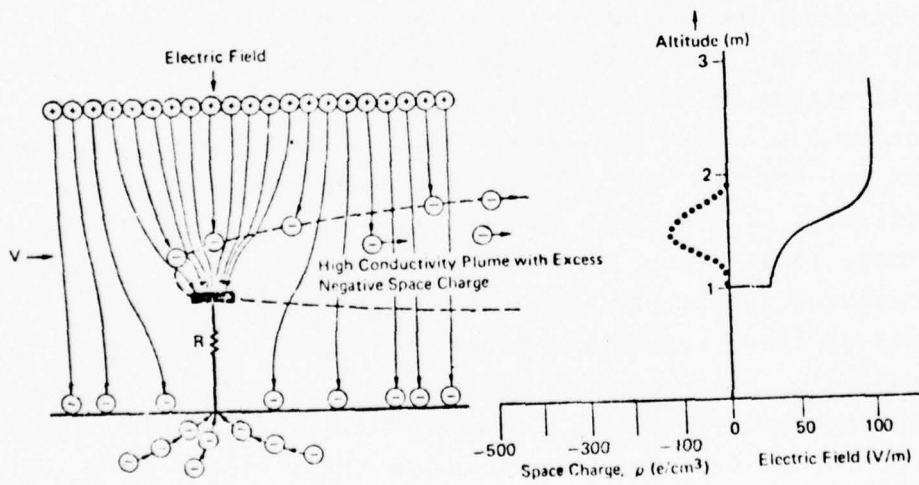

(b)

Figure 5
 Influence of ventilation on the
 space charge and electric field in
 the vicinity of an ionizing collector

If we now introduce strong ventilation around the collector, the situation changes to that shown in Figure 5b. A shielding layer of space charge still forms at the outer boundary of the conductive zone. However, the density of the space charge is reduced by rapid removal of negative ions by ventilation. This occurs because the nobility of the negative ions in the presence of an electric field is only on the order of $10^{-4} - 2 \times 10^{-4}$ ($m^2/V-s$). Thus, the motion of ions is dominated by gross air movement even at modest levels of ventilation. The reduced space charge results in a larger fraction of the field lines penetrating to the collector. The increased field in the neighbourhood of the collector produces a greater rate of ion deposition and, in turn, a larger voltage drop across the load resistor.

From the above discussion it becomes apparent that the output of a current sensor is likely to be influenced by fluctuations in the degree of ventilation. In an outdoor environment there are always mild breezes or convective eddies. Unfortunately, for the ventilation rates associated with personnel vulnerability sensors, the fluctuations in density of the space charge shield are sufficient to cause a severe noise problem.

Hill and Whyte⁴ have derived an expression for the current collected by a flat strip ionizer in the presence of transverse ventilation. Examination of this expression shows that the current is proportional both to the external field and to the air velocity for non-zero velocities up to about 5 - 10 meters per second. At high air velocities the current ceases to be dependent upon velocity, but becomes a function of external field and ionizer source strength. Experimental results obtained in a wind tunnel are in remarkably good agreement with theory.

The typical ventilation velocities in the vicinity of a personnel vulnerability sensor would fall within the range for which signal current is proportional to velocity. It must be concluded, therefore, that an ionizing collector operating in the current mode would prove prohibitively noisy.

D. Potential Probes

To overcome the noise inherent in current sensing devices it becomes necessary to devise a system which measures potential

rather than current. Further, as will be shown, even a potential probe must employ a geometrically tailored ionization zone to minimize the noise induced by fluctuations in the level of ventilation.

An ideal potential probe would have an infinite input impedance. However, the properties of an ideal probe can be realized by a device having a finite impedance when the effective impedance of the collector is small compared with the input impedance of the monitoring electronics. To examine the behaviour of such a probe let us consider the cylindrically symmetric configuration shown in Figure 6. Here the inner cylinder represents the radioactive collector and the outer cylinder defines the limits of the ionized sheath. In the idealized probe no current flows in the voltage sensing circuit. Thus, for a surface of symmetry, we can write:

$$\oint \vec{J} \cdot d\vec{S} = 0 \quad (20)$$

If the probe is surrounded by a moving gas which carries a charge density, e , and which has a velocity, V_x , parallel to the probe axis, then the current density is given by

$$\vec{J} = \gamma \vec{E} + e \vec{V}_x \quad (21)$$

where γ is the conductivity.

For a cylindrical Gaussian surface, coaxial with and of slightly larger diameter than the collector, \vec{V}_x and $d\vec{S}$ are perpendicular. Thus, the net enclosed charge is q , must be zero since:

$$\oint \gamma \vec{E} \cdot d\vec{S} = \gamma q = 0 \quad (22)$$

Further, because the conductivity will be constant over a surface of symmetry, the charge on the top half of the cylinder must be equal and opposite to that on the bottom half. Thus, the collector assumes the correct equilibrium potential. Negative space charge removed by the wind from the top half of the cylinder is balanced by an equal amount of positive charge removed from the lower half. If an initial charge is carried by the collector, or if a charge is imparted to the probe, it will dissipate rapidly through the conductive sheath with a time constant equal to ϵ/γ . Having collected at the boundary between the conductive sheath and the low conductivity atmosphere, it will be removed by the wind.

If, in contrast to the above situation, the ionized sheath is

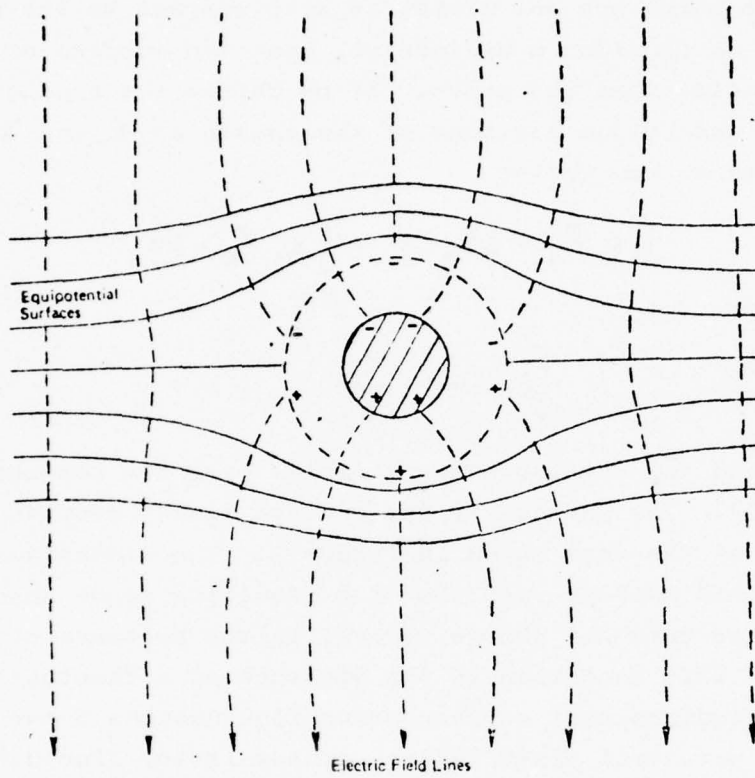

Figure 6
Equipotentials and electric fields around
a cylindrically symmetric probe

non-symmetric, there will be distortion of the equipotential surfaces. Consider, for example, the case of a cylindrical probe wherein the radioactive material is distributed such that the ionized sheath extends only in the upward direction. Such an arrangement will result in distributions of equipotentials and field lines which are not symmetric with respect to the probe. Again, let us consider a cylindrical Gaussian surface of slightly larger diameter than the probe. If we define the conductivities in the top and bottom portions of the sheath as γ_T and γ_B respectively, then we can write:

$$\int \gamma_T \vec{E}_T \cdot d\vec{S}_T = - \int \gamma_B \vec{E}_B \cdot d\vec{S}_B \quad (23)$$

which reduces to:

$$\frac{\vec{E}_T}{\vec{E}_B} = - \frac{\gamma_B}{\gamma_T} \quad (24)$$

where \vec{E}_T and \vec{E}_B are the average fields over the top and the bottom respectively. The inequality between the fields results in a field distortion of the form shown in Figure 7. The distortion of the electric field must be such that the resulting space charge distribution causes zero net charge removal in the presence of the wind. To maintain this condition in the presence of a fluctuating wind velocity, requires that corresponding fluctuations occur in the charge and potential distribution. These latter fluctuations will appear as spurious potential changes, or noise.

The above arguments illustrate the importance of maximum symmetry in the physical geometry of radioactive collectors. In particular it is important that probes designed for the measurement of vertical fields employ ionized zones which exhibit mirror symmetry about a horizontal plane which passes through the center of the collector.

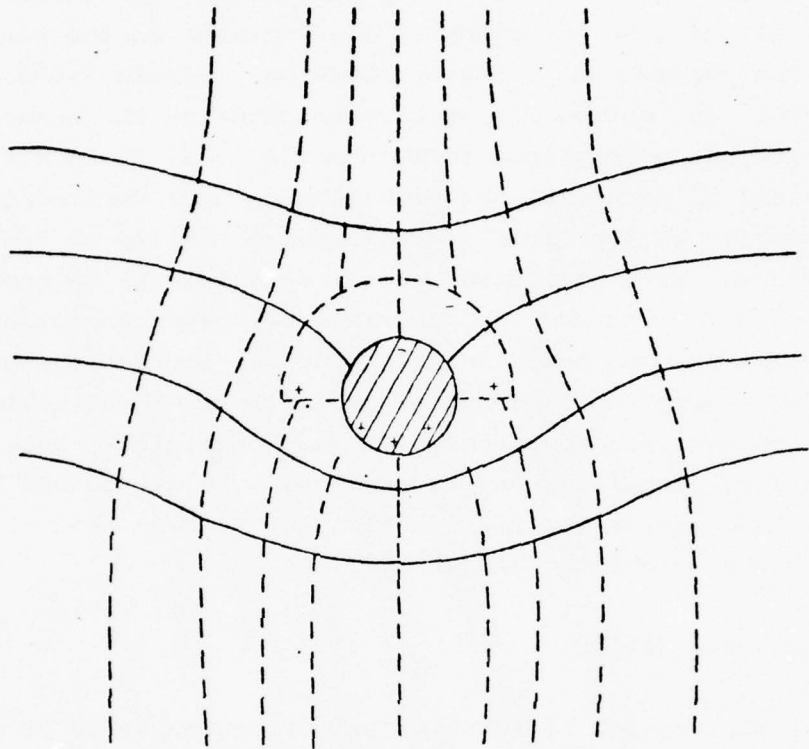

Figure 7
Equipotentials and electric fields around
a non-symmetric probe

V PRELIMINARY SYSTEM DESIGN

In Section II of this report we have examined the basic characteristics of the atmospheric field. In particular, we have established the magnitude of fluctuations in the field as a function of the period and area over which such fluctuations can be anticipated. In Section III we have established the manner in which orographic protrusions influence the local field strength. In the context of personnel vulnerability we have derived quantitative estimates of the field strength for a variety of postures and for different locations with respect to shielding objects. In Section IV we have examined the behaviour of probes employing radioactive collectors when operated in either the current or the potential mode. Using the information presented in these earlier sections, we are now in a position to discuss preliminary design specifications for a vulnerability sensing system. The discussion will be divided into two parts; the first dealing with probe design, and the second with the associated electronics.

A. Probe Design

The typical field which will be encountered by an individual sensor will be that associated with an upright man on open level terrain. Assuming an unaugmented field of 120 V/m, together with a helmet mounted sensor having an augmentation factor of about 30, the field at the sensor would be on the order of 3,600 V/m. The maximum fair weather field likely to be encountered would correspond to an upright man on a hill top in the presence of a polluted stable air mass. Under these circumstances the unaugmented field might be 250 V/m. Although fields in excess of this value exist over level terrain within heavily industrialized zones, they are not likely to be encountered on field maneuvers. The maximum augmentation associated with terrain contours may enhance the above field to the neighbourhood of 500 V/m. Again, stronger fields may exist where terrain related augmentation is exceptionally high; on the top of a rock pinnacle, for example. However, the 500 V/m figure seems to be a practical value which is likely to be exceeded only under rare combinations of circumstances. On this basis, using an augmentation factor of 30 for an upright man, we can anticipate maximum sensor

fields in the region of 15,000 V/m.

Typical high input impedance solid state electrometer circuits can handle input potentials of 250 - 300 volts with respect to case ground. A differential electrostatic voltmeter capable of handling inputs up to ± 500 volts has been built by Konigsberg²¹. However, this device is designed for a maximum of only ± 250 volts for each input. Thus, in the context of a vulnerability sensor, wherein it is desirable to use the helmet surface as case ground, the large differential capability offers no advantage. For a probe which provides an output of 300 volts in the presence of an augmented field strength of 15,000 V/m, the effective electrode separation must be 2 centimeters. For such a separation the output associated with more commonly encountered fields (500 - 5,000 V/m) will fall between 10 and 100 volts.

From the discussion of collector characteristics in Section IV, it is apparent that the ionized zone should be symmetrical with respect to the equipotential plane which passes through the center of the collector. However, if the field is to be measured over a distance as short as 2 centimeters, the ionizing range of alpha particles (about 3 cm) precludes the use of a spherically symmetric ionization zone. For a system wherein the surface of a helmet represents the reference plane, the ideal ionization zone would take the form of a thin circular disc; the axis of the disc being perpendicular to the helmet surface, and the separation between disc and helmet being 2 centimeters.

To achieve the necessary input impedance it is necessary that a conductive shield be used to isolate the collector. By maintaining the shield at essentially the same potential as the collector, any leakage current through the insulators surrounding the collector is kept to a minimum. However, since the shield is at an elevated voltage with respect to the helmet, it is necessary that it be physically inaccessible during normal use. It is desirable that the radioactive source also be recessed such that it is protected from direct handling.

A design satisfying the above requirements, while also providing a rugged and compact package, is illustrated in cross section in Figure 8. A vertical axis of rotational symmetry lies in the plane of the paper. The scale is approximately 1.4 times actual size.

To provide a thin anular disc of ionization a cylindrical

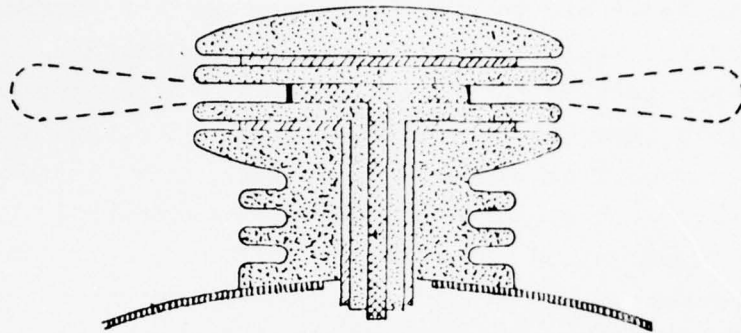

-  Insulator
-  Guard rings & shield
-  Collector
-  Helmet

Figure 3
Mechanical schematic of
helmet mounted sensor

radioactive collector has been recessed deeply between the adjacent insulators. The resulting ionization zone, which extends about 2 centimeters into the atmosphere, is shown in cross section by dashed lines in Figure 3. The radioactive source itself is envisioned as a thin strip of metallic foil attached by means of conductive cement to the periphery of the central collecting electrode.

A metal guard shield is comprised of two parts; the upper portion being a simple disc, and the lower being an integral disc and sleeve. The outer extremities of the guard discs are recessed to prevent accidental contact with external objects. Electrical contact between the upper and lower guard discs could be provided by countersunk rivets passing through the intervening insulators and collector electrode. Clearance holes through the central electrode would maintain electrical isolation between the collector and the guards. The upper portion of the guard serves partly to preserve electrostatic symmetry with respect to the collector, and partly to provide complete isolation between the collector and the exposed cap of the insulator. However, it may prove practical to omit this portion of the guard; thereby simplifying the design.

The insulating body of the probe should be made of a non-wetting, high resistivity material such as teflon. Assembly details should be such that no conductive fasteners interfere with the overall electrostatic symmetry of the helmet / guard ring / collector geometry. Thus, the lower stand-off portion of the insulator should act only as a spacer. An isolation washer and retaining nut at the bottom extremity of the lower guard sheath could provide an effective means for assembly. Similarly, the top cap insulator should not employ screws. A "snap-on" arrangement should be adequate. Because of the guard rings, one is not concerned about small surface leakage currents on the outside of the stand-off portion of the insulator. Thus, it may be possible to simplify the stand-off design by elimination of the external convolutions.

The radioactive foil employed in the collector should contain polonium 210. Since the residual ventilation noise increases with the activity of the radioactive source, the amount of polonium should be sufficient only to provide a satisfactorily low coupling impedance together with some tolerance for natural decay. Using a hemispherically exposed flat source, Leffel and Hill⁴ have found

that the source strength can be reduced to about 10 microcurie without affecting either the accuracy of the potential reading or the response time of the instrument. Since the proposed probe design confines the effective angle of emission in one plane to about 10 degrees, the source strength must be increased by a factor of about seven to achieve the same ion pair production rate in the atmosphere. Thus, the minimum source strength would be about 70 microcuries. Allowing for a reasonable period of natural decay, the initial source strength should be 150 - 200 microcuries.

B. Electronic Design

The electronics associated with atmospheric field probes must exhibit extremely high input impedance combined with the ability to handle high voltage signals. The effective coupling impedance of radioactive collectors has been estimated^{1,4} at various values ranging from 2×10^{10} to 5×10^{11} ohm. For the low activity shielded collector of the proposed design, it seems reasonable to assume a coupling impedance of 10^{12} ohm or less. Thus, for operation in the potential mode an optimum preamplifier input stage should have an input impedance of 10^{14} ohm or greater.

A simple circuit meeting the above criteria has been used successfully by Teng and Johnson¹⁰. By employing an insulated gate field effect transistor (IGFET) in the input stage, they claim to achieve an input impedance in excess of 10^{15} ohm. Their probe output is connected directly to the gate of the input IGFET. However, since the gate drain voltage is critical with respect to device breakdown, they have incorporated a feedback arrangement such that the input IGFET is exposed only to the small difference voltage between the probe potential and the output of the unity gain electrometer circuit. In their experiments the probe consisted of a passive copper mesh antenna, and no guard rings were employed; the output voltage being applied only to the input IGFET. For a radioactive collector of the type proposed for vulnerability sensing the feedback would be applied to the guard rings also. Incorporating this minor change, a block diagram of the system would be as shown in Figure 9a. In a practical vulnerability sensor the output from the high voltage stage would be fed to an adjustable gain stage.

The details of a suitable circuit are shown in Figure 9b. The three principal stages of the electrometer comprise a preamplifier,

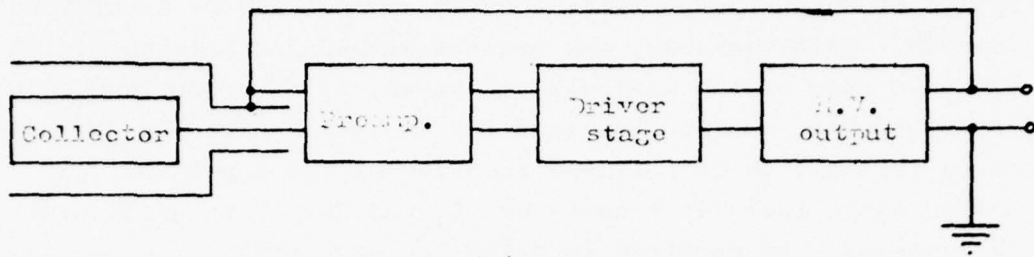

(a)

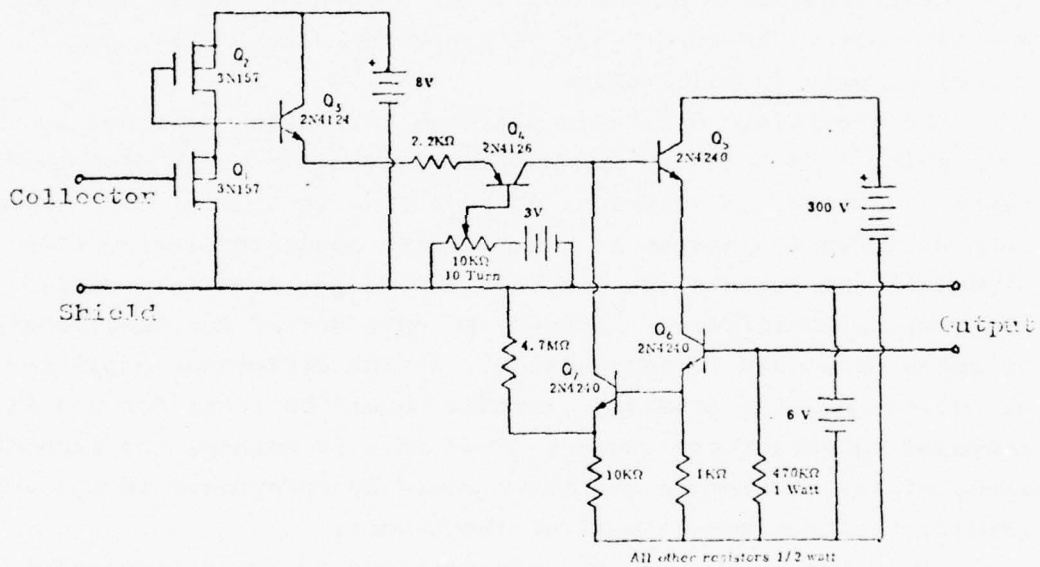

(b)

Figure 9
Block diagram and circuit
of electrometer system

a driver, and an output stage. The preamplifier incorporates two IGFET's, Q_1 and Q_2 , connected as a source follower. The characteristics of such a preamplifier have been analysed by Oswald and Joper²². Unfortunately, the present author has been unable to obtain a copy of the analysis. However, it is understood from the report of Yerg and Johnson that the analysis shows the preamplifier output voltage to be a linear function of the input voltage. The driver stage includes transistors Q_3 and Q_4 . This stage provides the current gain required to drive the high voltage stage. The output stage includes the three high voltage transistors, Q_5 , Q_6 and Q_7 . Transistor Q_5 is operated as an emitter follower; Q_6 being an active load. Compensation for leakage current in Q_5 is achieved by operating Q_7 as a constant current source.

Tests conducted by Yerg and Johnson on a circuit similar to that described above showed that, for input potentials in the range 5 - 250 volts, the error voltage appearing across the input IGFET varies by only 50 millivolts.

The previously mentioned differential device designed by Konigsberg²¹ is somewhat more sophisticated than that described above. However, in principal of operation it is very much the same. As a differential device it contains two separate electrometer circuits; the outputs of which are fed in parallel into differencing and summing amplifiers. However, if only one of the electrometer circuits were used in conjunction with the difference amplifier output stages, the resulting circuit should be ideal for use in the proposed vulnerability sensor. Used in this manner, the second input of the difference amplifier would be referenced to the system ground; i.e. the metal shell of the helmet.

Since the basic electrometer employed in the differential device is so well suited to the present application, a copy of Konigsberg's detailed paper on its design and operation will be attached to this report. It is understood via private communication that the paper has yet to be published; the attached copy having been duplicated from an internal Johns Hopkins University report.

In comparing the Konigsberg circuit with that employed by Yerg and Johnson, there are two features associated with the former which render it more attractive as the basis for the input stages of a vulnerability sensor. First, the Konigsberg circuit already incorporates an adjustable gain amplifier permitting the full scale response to vary over a fifty to one range. Continuous gain adjustment could be achieved by replacing the six fixed feedback

resistors by a 500 Kohm potentiometer in series with a 10 Kohm resistor. Also, in the Honigsberg circuit the inputs of the DCC's are protected from excessive input currents by the inclusion of a large resistance in series with the input nodes. As additional protection it would seem reasonable to place a shunt of about 10^9 ohms between the collector and the shield of the probe. Within the design voltage range the high gain of the input DCC ($> 10^5$) would cause the apparent resistance of the shunt to be in excess of 10^{14} ohm; i.e. several orders of magnitude greater than the probe contact resistance. In an overdriven condition, however, the shunt would approach its real value of 10^9 ohm. Since this lower value is much less than the contact impedance, the collector potential would be prevented from rising significantly above that of the isolated ground.

A high gain on the part of the input DCC is desirable in so far as the allowable leakage conductance between the collector and its shield is directly proportional to the gain. To achieve the desired input impedance of 10^{14} ohm with a DCC gain of 10^5 , the total leakage conductance must be 10^{-9} mho or less. Typical DCC input DCC's have input conductances of 10^{-11} mho. Thus, it is not difficult to find amplifiers to satisfy this requirement. However, to maintain this low value of conductance in the presence of accumulated dirt on the exposed insulator surfaces of the probe may be quite difficult. If this problem arises, it can be minimized in three ways; namely by increasing DCC gain, by using a more intense radioactive source to lower the contact impedance, and by accepting a lower ratio of input impedance to contact impedance. An acceptable combination of these measures should enable the allowable leakage conductance to increase by at least an order of magnitude.

A final comment about the Honigsberg circuit concerns its power consumption. The present design consumes 1.8 watts. As a single channel system this figure would be cut to about 0.5 watts. However, the consumption should be reduced further if possible. Certainly the non-optimum step-up ratio of the transformer in the present design should be corrected.

A circuit of the Honigsberg type would provide an output which is well suited for use as a vulnerability weighting factor. Also, the adjustable gain output facilitates both calibration and periodic adjustments to correct for changes in the local atmospheric field. However, there is no automatic gain control which could be operated in conjunction with a compensation input from a local atmospheric

field monitor. As was noted at the end of Section II, it is far from certain that automatic compensation will be required. Using a fixed gain setting based upon the anticipated field strength for each day may prove quite adequate. However, if it should develop that some form of continuous correction is required, then it would seem that such a correction could be included in the designation code employed by the indirect fire simulator.

References

1. J.A. Chalmers, "Atmospheric Electricity", Pergamon Press, 1967
2. H. Israël, "Atmospheric Electricity", Vol I & II, Israël Program for Scientific Translation Ltd., National Science Foundation, Washington, D.C., 1973
3. A. Dolensak, "A Discourse in Atmospheric Electricity. Part I, Fundamentals and Fair Weather Electricity", 1975. (Notes of Chataouga Lecture Series.)
4. H.B. Hill and T.A. Myte, "Investigations related to the use of atmospheric electric fields for aircraft and RPV stabilization", Johns Hopkins University Applied Physics Laboratory report 23 1280, June 1975.
5. C.B. Leffel and H.L. Hill, "Use of the atmospheric electric field for terrain avoidance", Johns Hopkins University Applied Physics Laboratory report 23 1271, April 1975.
6. J.M. Hradkevick and J.F. Clarn, "Airborne measurements of atmospheric electricity", Transcript. Geophys. Union, Vol. 39, 1953, p.327
7. C.H. Fish, "Evaluation and interpretation of the columnar resistance of the atmosphere", Terrestrial Magnetism and Atmospheric Electricity, Vol. 49, 1944. p.159
8. H.E. Large, "Some investigations in atmospheric electricity", Ph.D. thesis, Cambridge Univ. Cambridge, England, 1957.
9. H.D. Stringfellow, "The electrical structure of nimbostratus clouds", Ph.D. thesis, Univ. of Durham, Durham, England, 1969
10. D.L. Terry and P.L. Johnson, "Short-period fluctuations in the fair-weather electric field", J. Geophys. Res., Vol. 79, No. 15, May 1974, p.3177
11. F.S.S. Mipple and F.S. Scrase, "Point discharge in the electric field of the earth", Geophys. Mem. London, Vol. VII, No. 60, 1935
12. M.J. Whitlock and J.A. Chalmers, "Short-period variations in the atmospheric electric potential gradient", Quart. J. Roy. Meteorol. Soc. 82 (353), pp.325-326, 1956
13. F. Knott and T. Schumann, "Short period variation of the atmospheric electric potential gradient", Arch. Met. Geoph. Biokl., Series A, No. 21, pp.319-327, 1972
14. E.M. Trent and R.V. Anderson, "Data from a system of atmospheric electricity stations", U.S. Naval Research Laboratory Report 6162, May 1965
15. Kwang Yu, "Atmospheric electrostatic field near a mountain ridge", Johns Hopkins University Applied Physics Laboratory internal memo QM-74-050, April 1974

**COPY AVAILABLE TO DDC DOES NOT
PERMIT FULLY LEGIBLE PRODUCTION**

15. W.A. Moppel, "Altitude variations in the electric potential resulting from orographic features", Pure and Applied Geophysics, Vol. 84, pp.57-66, 1971
17. J.M. Kravtchik and W.A. Moppel, "Atmospheric electric characteristics of regions", NRL Report 6652, 1967
18. R.M. Kasehir, "The cylindrical field mill", Army Electronics Command Report, ECOM 2526, 1964
19. S.C. Matheson and R.V. Anderson, Rev. Sci. Instruments Vol. 36, 1965, pp.1490-1493
20. R.L. Hill and W.A. Moppel, "Effects of velocity and other physical variables on the currents and potentials generated by radioactive collectors in electric field measurements", presented at the Fifth International Conference on Atmospheric Electricity, Garmisch-Partenkirchen, F. Germany, Sept. 1974
21. R.L. Konigsberg, "Design of a portable, solid state, high input impedance high voltage differential electrostatic voltmeter", to be published
22. J.A. Oswald and J.M. Cooper, "Analysis and characterization of insulated gate field effect transistors in basic circuitry", internal report, Raytheon Semiconductor Div., Mountain view, Calif. 1965

APPENDIX B

RELATIVE VALUES OF COMPETING SYSTEMS

RELATIVE VALUES OF COMPETING SYSTEMS

A. DISCUSSION

International Laser Systems, Inc. is required to provide analyses of systems performance and risks and systems tradeoffs as a part of Contract Item 0004. ILS has lumped these requirements together under the title "Values". System costs are estimated separately.

The purpose of the systems is training of troops in the avoidance and use of indirect fire. The positive values must all be reflected in effectiveness in training. The pejorative factors are:

- Complexity and cost of acquisition and maintenance;
- Numbers and costs of personnel required to operate the system; and
- Negative factors in training effectiveness such as:
 - Unrealistic times between call for fire and delivery of effect;
 - Unrealistic P_k versus weapon type and exposure or type of target;
 - Excessive inadvertent advance cueing by any system element;
 - Inadequate audio or visual cueing -- a psychological factor that is hard to evaluate;
 - Confusion of cues, for example, use of the same synthetic cue for direct-fire near miss and indirect-fire audio cue.
 - Inadequate accuracy of placement of fire-effects simulation; and
 - Either excessive or inadequate area coverage of indirect fire "incident" simulation.

Notably, the pejorative factors far outnumber the single positive factor of effectiveness in troop training. However, the can consider several positive variables, most of which can only be predicted without initial field experience as suggested for the "Concept Evaluation Program" as follows:

- Do troops react with surprise and consternation to an unexpected audio or kill signal?

F_p = protective measures fidelity factors (min value 0.3)

$$V_F = \sqrt[3]{F_A F_V F_p} = \text{fidelity value } < 1.$$

Multiply by 0.50 if not accompanied by larger area audible cue. Make this factor 0.30 if the cue is not distinctive.

T_1 = Time from call of fire to execution of kill effects factor, 1.0 if realistic, proportionately less if longer.

T_2 = Factor for time from beginning of execution of kill effects to completion of effects for one round. 1.0 if 2 sec. or less, proportionately less if longer. Minimum value 0.02 if very long.

T_{36} = Factor for time from beginning of execution of kill effect to completion of effects for 36 rounds, one target area/battery/cuer. 1.0 if equivalent to 6 tubes delivery time, proportionately less if greater. Minimum value .02 if very long.

t_1 = time from call of fire by F.O. to first visual effect. 1.0 if less than 4 minutes proportionately less if longer: cuer displacement required = 1 km.

t_2 = time from visual effect to second visual effect: 1.0 if less than 3 minutes, proportionately less if longer. Displacement required = 600 meters.

t_6 = time from call of shell smoke simulation to completion of execution of 6 rounds coverage, assume 2 km displacement needed. 1.0 if 5 minutes or less, proportionately less if greater. Displacement required = 2 km.

$$V_T = \sqrt[3]{T_1 T_2 T_{36}} \sqrt{K_C K_V}, \quad V_t = \sqrt[3]{t_1 t_2 t_6}$$

(time values)

$$\text{Total Value Score} = V_F \sqrt{V_T V_t}$$

(This gives greater effect to kill fidelity than to the time factors).

Values of K_C , K_V

K_C = Inadvertent cueing factor:

Make $K_C = 0.6$ if visual cuers must move about in full view of troops looking toward enemy. Make $K_C = 0.7$ if they move about only in the rear or intermixed with target forces.

$K_V = 1.0$ if visual cue is fully visible from 4km with intervening trees close to cue, 0.7 if limited to 2-km.
(all backgrounds, in presence of smoke at same range)
0.5 if limited to 1-km.

Multiply K_V so obtained by 0.6 if no night-visible cue.

C. ESTIMATION OF VALUE FACTORS

The components of the "fidelity" factor V_F ,

- area fidelity F_A
- vulnerability fidelity, F_V
- Protective measures fidelity F_P

are given equal weight in $V_F = \sqrt[3]{F_A F_V F_P}$.

In order that any scheme which works at all shall not have zero ultimate value, we take a minimum value of each of these factors as 0.30. (as noted previously, this analysis is merely a scheme for ranking the system concepts in their values as training systems. It is important that the results not be interpreted as an accurate, linear measure of value, but only very approximately so.)

1. F_A Factors

The RF multilateration scheme, as envisioned with practical bandwidths, would designate a signal decodable area which is somewhat large for most of the weapon types. In others, the designation point would need to be rapidly shifted to cover a large area in sequential signal transmissions. Because of terrain contours, signals often would be received over a path-length of propagation exceeding the theoretical line-of-sight, with a resultant shift in the designation-point from the ideal. These factors lead us to assign $F_A = 0.5$, which is somewhat better than the minimum for the RF system concept.

In Systems 1 and 2, the concept of "Area" is entirely synthetic -- that is, laser operators will signal a certain number of "victims" regardless of their actual location. We assign $F_A = 0.3$ = the minimum.

In System 3, location capability of operators allows them to use judgement in modification of the instructions of the SNCS. If targeted elements have evacuated the target area, no kill effect would be applied. This leads to assignment of $F_A = 0.4$.

In System 4, with favorable aspect, the actual lethal area is illuminated by the laser scan and area fidelity is good, but often aspects may be poor. Therefore, we assign $F_A = 0.7$. In System 4-A, with an elevated laser, area fidelity will be excellent, but location accuracy may be somewhat less than System 4. We assign $F_A = 0.9$. These values for F_A for Systems 4 and 4-A carry through these systems with added vulnerability-assessment subsystems and separate distinctive audio cueing.

2. F_V Factors

In the RF scheme and in System 4-A with high elevation aspect of the target area, virtually every target element within the desired area will be signaled. These elements are assigned a value of $F_V = 0.85$, because they will be able to decode all weapon-type signals and respond with the proper probability. System 4 is assigned $F_V = 0.75$.

In systems 4₁ and 4-A(1), where this weapon-type decoding is not done in troop equipment, but rather the probability of kill is introduced by intermittent signals during scan, the vulnerability

is a function of depression-angle and considerably more or less than the proper proportion of targets may be "killed". These are assigned $F_V = 0.65$.

3. F_p Factors

In the factors for effectiveness of protective measures, Systems 1 and 2 do not offer any means of introducing the F_p factor. They are assigned the minimum value of 0.3. In System 3, the effect of evacuation of a target area in response to fire adjustment cues is effective and we assign $F_p = 0.45$. In System 4 and 4₍₁₎ the effect of taking a prone or defiladed position is such as to reduce the probability of illumination and so affects the P_k realistically. We assign $F_p = 0.60$. In Systems 4-A and 4-A₍₁₎, the^k high elevation works against this factor and $F_p = 0.40$. When we add the vulnerability subsystem to these, we should get a great improvement in F_p and so we assign $F_p = 0.85$. When we add the distinctive audio cue, this is further improved to 0.95. The F_p value for the RF system is always very high (provided the vulnerability-assessment subsystem is used) and F_p can be taken as 0.95. Taking the cube root of the products of F_A , F_V and F_p we obtain the value factors V_F for the "fidelity" value.

4. Weapon-Effects Time Factors

The components of the weapon-effects time factor value, V_T , are the time from call-of-fire to execution of kill-effects signaling T_1 , the time from beginning to completion of single-round effects, T_2 and the time from beginning of kill effects simulation to completion of 6 salvos of 6 rounds from one battery, T_{36} .

We assume here that there are adequate numbers of equipments and personnel fielded and that they have adequate transportation for the type of terrain (jeeps, motorcycle and the like, as needed).

For all of the systems considered $T_1 = 1.0$. For all systems except 1, 2 and 3, T_2 can also be taken as 1.0 (see Figure B-1). For the latter systems, the deliberate illumination of a number of targets is unrealistically long, so we take $T_2 = 0.20$. These latter systems also have an extremely long time to execute the effects of 36 rounds over an extended area, so we take T_{36} at the minimum 0.02. This very low value is taken because the operator(s) moving about to achieve this effect would be very obvious and the

TYPICAL BATTERY FIRE MISSION "BATTERY ADJUST, 2 ROUNDS"

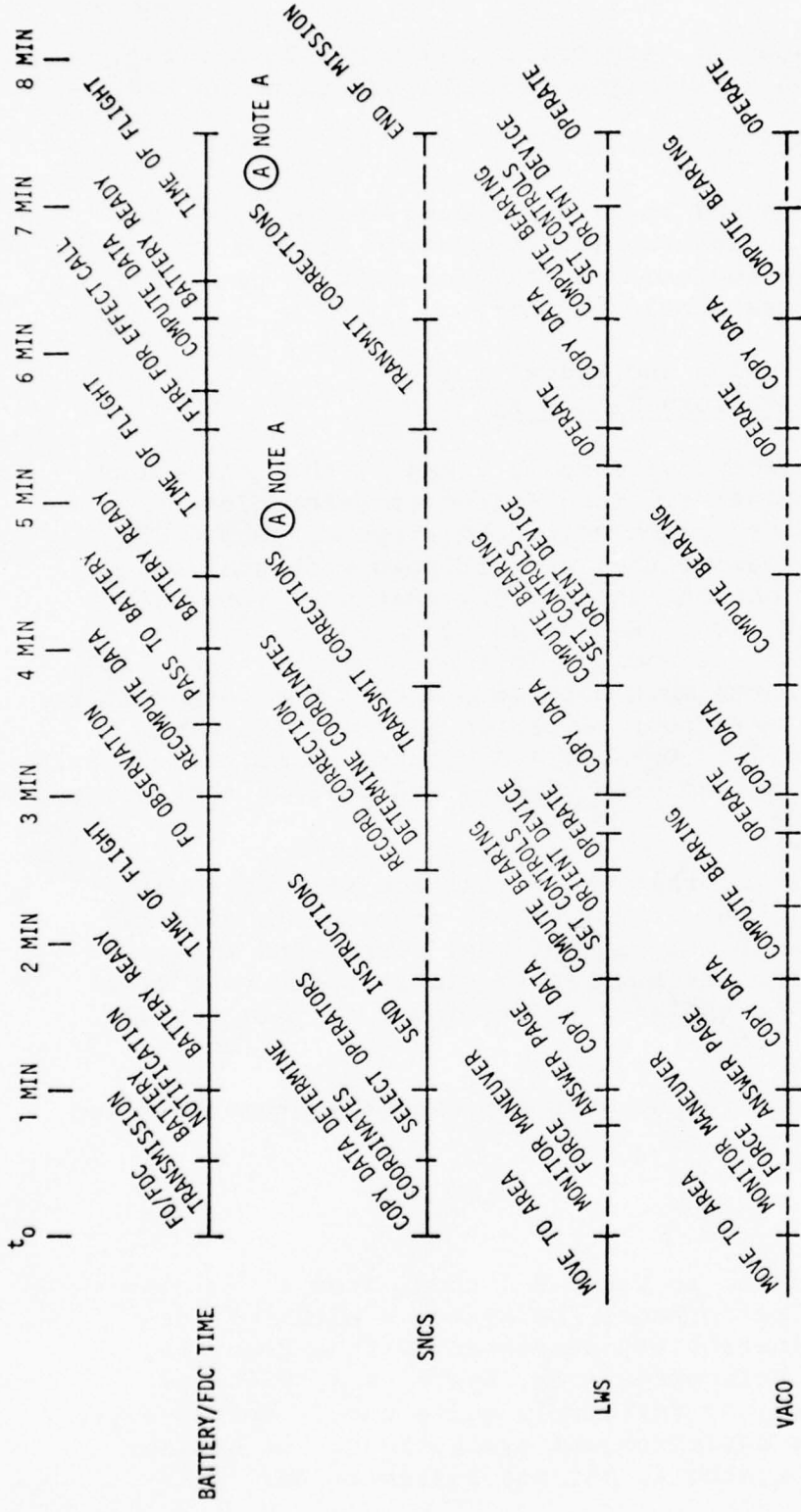

1. LWS AND VACO ASSUMED IN POSITION AT t_0 BY VIRTUE OF PREPLANNING, SNCS DIRECTIONS, DATA FROM MONITORED TRANSMISSIONS AND THE LIKE.
2. BATTERY AND FDC OPERATING TIMES EXTRACTED FROM LEVEL 1 REQUIREMENTS OF ARTEP 6-365. TIME OF FLIGHT ESTIMATED 1 MINUTE.

(A) SOP'S WILL DICTATE NEED FOR RECOMPUTING AZIMUTH/RANGE FOR SUBSEQUENT ROUNDS BASED ON MINIMUM CORRECTION CRITERIA.

P3203

Figure B-1. Typical Battery Fire Mission: "Battery Adjust, 2 Rounds"

training value is consequently very poor. All other T_2 and T_{36} values are well within the limits required and are taken as 1.0.

5. Cue Time Factors

For the visual cue and shell smoke simulation, using the recommended schemes and again assuming adequately rapid transportation and the use of the recommended position-finding gear, all of the t_1 , t_2 and t_6 values should be unity.

6. Inadvertent Cueing and Visual Cue Visibility Factors K_C and K_V

For all systems except systems 1, 2 and 3, the kill cuers can maintain positions relatively remote from targeted elements and are not very obvious to troops doing their proper jobs. The visual cuers need to be closer, they are equipped with smaller devices and are not very obvious unless they must move forward of troops to place visual cues. We can assign a value of 0.7 for K_C to all but systems 1, 2 and 3. In these systems, the "kill designators" and visual cuers must both move about; the former quite rapidly and very obvious -- a poor situation for good training. To these we assign $K_C = 0.2$. For the 4-A systems using helicopters, the movements and sounds are so very visible and obvious that we assign $K_C = 0.3$.

We assume here, also, that the visual cue will be a well-developed round. However, the actual visual and audible effects will be much smaller than in the case of real rounds and in some cases will not be used in a way such as to simulate the real fires (such as massed fires). We assign a value of 0.7 to this for all systems.

Then, $\sqrt{K_C K_V} = 0.7$ for all systems except systems 1, 2 and 3. For the latter, $\sqrt{K_C K_V} = 0.374$.

D. RESULTS

The results tabulated in Table B-1 show, from a training value viewpoint, a clear performance for System 4 with full decoding capability and vulnerability assessment with a separate, distinct audio cue. The Helicopter mode, System 4-A, with its obvious inadvertent cueing, is relatively quite poor. System 4(1), with the unmodified troop equipment and synthetic P_k , is noticeably lower in value than System 4, but not extremely so.

Table B-1. Basic System Values

| System | F _A | F _V | F _P | V _F | T ₁ | T ₂ | T ₃₆ | t ₁ | t ₂ | t ₆ | K _C K _V | V _T | V _t | V _s |
|-----------------------|----------------|----------------|----------------|----------------|----------------|----------------|-----------------|----------------|----------------|----------------|-------------------------------|----------------|----------------|----------------|
| RF | 0.50 | 0.85 | 0.95 | 0.74 | 1 | 1 | 1 | 1 | 1 | 1 | 0.7 | 0.7 | 1 | 0.518 |
| 1 | 0.30 | 0.30 | 0.30 | 0.30 | 1 | .2 | .02 | 1 | 1 | 1 | 0.374 | 0.059 | 1 | 0.112 |
| 2 | 0.30 | 0.30 | 0.30 | 0.30 | 1 | .2 | .02 | 1 | 1 | 1 | 0.374 | 0.059 | 1 | 0.112 |
| 3 | 0.40 | 0.30 | 0.45 | 0.378 | 1 | .2 | .02 | 1 | 1 | 1 | 0.374 | 0.059 | 1 | 0.141 |
| 4 | 0.70 | 0.75 | 0.60 | 0.980 | 1 | 1 | 1 | 1 | 1 | 1 | 0.17 | 0.7 | 1 | 0.476 |
| 4-A | 0.90 | 0.85 | 0.40 | 0.674 | 1 | 1 | 1 | 1 | 1 | 1 | 0.21 | 0.21 | 1 | 0.141 |
| 4 (1) | 0.70 | 0.65 | 0.60 | 0.649 | 1 | 1 | 1 | 1 | 1 | 1 | 0.7 | 0.7 | 1 | 0.454 |
| 4-A (1) | 0.90 | 0.65 | 0.40 | 0.616 | 1 | 1 | 1 | 1 | 1 | 1 | 0.21 | 0.21 | 1 | 0.129 |
| 4+Vuln. | 0.70 | 0.75 | 0.85 | 0.764 | 1 | 1 | 1 | 1 | 1 | 1 | 0.7 | 0.7 | 1 | 0.535 |
| 4-A+Vuln | 0.90 | 0.85 | 0.85 | 0.866 | 1 | 1 | 1 | 1 | 1 | 1 | 0.21 | 0.21 | 1 | 0.182 |
| 4+Vuln and Audio | 0.70 | 0.75 | 0.95 | 0.793 | 1 | 1 | 1 | 1 | 1 | 1 | 0.7 | 0.7 | 1 | 0.555 |
| 4-A+Vuln and Audio | 0.90 | 0.85 | 0.95 | 0.899 | 1 | 1 | 1 | 1 | 1 | 1 | 0.21 | 0.21 | 1 | 0.189 |

NOTE: See Table B-2 for system values considering Night and Weather capabilities.

The cost factor in choice between System 4 (enhanced) and System 4(1) with a ratio of

$$\frac{0.555}{0.454} = 1.22$$

will influence the choice which probably will have to be done pragmatically.

Systems 1, 2 and 3 are quite low in relative system values and not greatly less in actual costs because a great factor in overall costs is the cost of system operation -- approximately the same for all systems, except the RF multilateration scheme. The latter scheme has a relatively lower cost of operation because kill-effects designators need not be fielded. However, the RF system has a rather high cost of acquisition and maintenance, largely because it must be completely overlaid on the MILES system. The RF system does have a quite good value factor, which is slightly more than System 4 (enhanced).

E. MODIFICATION OF BASIC VALUES FOR ADDITIONAL FACTORS

The variables not considered in the preceding analysis are:

- Night vs. Day visibility; and
- Weather.

Several things can be done to enable the systems to be effective night and day. Weather conditions unavoidably attenuate laser radiation, but have little effect on RF propagation. The net multiplying factor for the RF system thus can be taken as 1.0. The laser systems are not of zero effectiveness at night, but the accuracy of placement of Systems 4 and 4-A (all modifications) is affected without some assistance by night-vision aids.

As noted by General Tal (Israeli Tank Commander in the "Six Day War"), an active battlefield is never really dark because of the number of fires that result from many sources. This fact, coupled with the use of the new night vision goggles used typically for nap of the earth (NOE) flight of helicopters in low light levels, allows an add-on set of components to (effectively) maintain nearly full daylight effectiveness at night:

- Night-vision goggles for all fielded system personnel.
- Long-burning simulated "battlefield fires", typically an oil drum and burner using crude or refinery residual oils as used by electric power plants.

This leaves the question of the weather. As noted, the laser systems degrade as a function of atmospheric visibility. Ranges become poor in fog or snow and are degraded in rain. It thus seems fair to take a 0.70 additional factor for the laser systems unenhanced by night vision capability and 0.95 with it for night effectiveness and 0.95 additionally for weather effects. Net factors are:

- RF system: 1.0
- Enhanced Laser Systems: $0.95 \times 0.95 = 0.9025$
- Unenhanced Laser Systems $0.95 \times 0.70 = 0.665$

The value factors for the several systems, all factors considered, are summarized in Table B-2.

Table B-2. Value Factors for All Systems

| <u>System</u> | <u>Vs</u> | |
|--|-----------|---|
| RF Multilateration | 0.518 | 1 |
| System 1 | 0.0745 | |
| System 2 | 0.0745 | |
| System 3 | 0.0938 | |
| System 4 (Unenhanced) | 0.3165 | |
| System 4 (Vulnerability Assess. Added) | 0.356 | |
| System 4 (Vuln. Assess. & Distinct Audio Added) | 0.369 | |
| System 4 (Vuln. Assess, Distinct Audio & Night Cap) | 0.501 | 2 |
| System 4-A (Unenhanced) | 0.094 | |
| System 4-A (Vulnerability Asses. Added) | 0.121 | |
| System 4-A (Vuln Assess. & Distinct Audio Added) | 0.126 | |
| System 4-A (Vuln Assess. & Distinct Audio & Night Cap) | 0.170 | |
| System 4(1) (No Vuln. Assess or Distinct Audio Feasible) | 0.301 | |
| System 4(1) (With Night Capability Added) | 0.410 | 3 |
| System 4 _{A(1)} (4 ₁ Helicopter-Borne) | 0.086 | |
| System 4 _{A(1)} (With Night Capability Added) | 0.116 | |

Clearly, from the viewpoint of value in training effectiveness, the RF multilateration scheme is to be preferred, except in hilly terrain where it is likely to be quite inaccurate. From the viewpoint of costs, it must be remembered that the RF system must be completely overlaid on MILES for all targets, including troops. Further, the developmental risks and costs will be high and an estimated 2 to 3 years would be required before such a novel scheme could be tested initially. The fully enhanced System 4 (not helicopter borne) is not far behind in training value. It is well within current state-of-the-art, and needs only minor modification of MILES.

Without impacting MILES that is, not adding the vulnerability assessment and distinct audio cue, System 4 with night capability appears to have a value of about 80% that of the fully enhanced system. It must be remembered, however, that this scheme does not train troops to take individual protective measures and the lack of a distinctive audio cue will be confusing.

The helicopter-borne system fares poorly because of the severe inadvertent cueing. It is a feasible mode, however, which can be used in special circumstances.

APPENDIX C

LASER WEAPON SIMULATOR - AREA KILL

TABLE OF CONTENTS

| <u>Section</u> | <u>Title</u> | <u>Page</u> |
|----------------|--|-------------|
| A | OPERATIONAL CONSIDERATIONS | C-3 |
| B | OPERATIONAL REQUIREMENTS | C-3 |
| C | DESIGN CONCEPT | C-7 |
| D | LASER DESIGN | C-15 |
| | 1. GaAs Source | C-15 |
| | 2. Beam Forming Optics | C-15 |
| | a. Optimization | C-15 |
| | b. Beam Adjustment | C-23 |
| | c. Beam Power Density Distribution | C-23 |
| | d. Lens Selection | C-25 |
| | 3. Gimbaled Mirror | C-27 |
| | 4. Electronics | C-27 |
| | a. Controls | C-27 |
| | b. Beam Divergence Sensor | C-32 |
| | c. Microprocessor Input Interface | C-32 |
| | d. Microprocessor | C-33 |
| | e. Microprocessor Output Interface | C-51 |
| | f. Gimbal Control | C-51 |
| | g. Pulse Code Generator | C-53 |
| | h. GaAs Laser Driver | C-58 |
| | i. Sight Display Drive | C-58 |
| | j. Power Supply and Battery | C-62 |
| | 5. Depression Angle Sensor | C-68 |
| | 6. Sight/Display | C-72 |
| | 7. Configuration | C-75 |
| E | PERFORMANCE | C-77 |
| | 1. Eye Safety | C-77 |
| | 2. Range | C-84 |
| | 3. Scan Time | C-87 |

LIST OF ILLUSTRATIONS

| <u>Figure</u> | <u>Title</u> | <u>Page</u> |
|---------------|--|-------------|
| C-1 | Laser Weapon Simulator | C-8 |
| C-2 | Indirect/Area Fire Simulation System Electronic Block Diagram | C-9 |
| C-3 | GaAs Source Characteristics | C-16 |
| C-4 | GaAs Source Configuration | C-17 |
| C-5 | Optical Collection Efficiency for Laser Diode Radiation Patterns | C-18 |
| C-6 | Optics Optimization Curve | C-21 |
| C-7 | Defocusing to Produce Large Beam Divergence | C-24 |
| C-8 | Defocused Power Density Distributions | C-26 |
| C-9 | Controls and Input Interface | C-29 |
| C-10 | Microprocessor and Input/Output Interface Electronic Block Diagram | C-35 |
| C-11 | Basic Program Flow | C-37 |
| C-12 | Program Flow to be Implemented | C-40 |
| C-13 | Elevation Kill Angle Geometry | C-47 |
| C-14 | Scan Pattern | C-50 |
| C-15 | Gimbal Control Block Diagram | C-52 |
| C-16 | Elevation and Azimuth Gimbal Control | C-55 |
| C-17 | Pulse Code Generator | C-57 |
| C-18 | Laser Driver Electronics | C-59 |
| C-19 | Sight Display Control (1 of 3 Circuits) | C-61 |
| C-20 | Power Supply | C-63 |
| C-21 | Depression Angle Sensor | C-71 |
| C-22 | Sight Optical Schematic | C-73 |
| C-23 | Display | C-74 |
| C-24 | Protection Standard for Intrabeam Viewing of Pulsed Visible (400-700 nm) Laser Radiation | C-78 |
| C-25 | Protection Standard for Extended Sources of Diffuse Reflections of Pulsed Laser Radiation | C-79 |
| C-26 | Limiting Angular Subtense of an Extended Source | C-80 |
| C-27 | Range Performance | C-85 |
| C-28 | Scan Time Performance | C-88 |
| C-29 | Simulation Footprint | C-91 |

LIST OF TABLES

| <u>Table</u> | <u>Title</u> | <u>Page</u> |
|--------------|---|-------------|
| C-1 | Single Round Lethal Diameter | C-5 |
| C-2 | Volley Fire | C-5 |
| C-3 | Optical Transmission | C-19 |
| C-4 | Power Supply Input Requirements | C-65 |
| C-5 | Electrical Characteristics of Primary Batteries . . | C-67 |
| C-6 | Electrical Characteristics of Secondary Batteries . | C-69 |
| C-7 | "Gel" Cell Optional Design | C-70 |
| C-8 | Scan Parameters for Given Simulation Conditions . . | C-90 |

LASER WEAPON SIMULATOR - AREA KILL

A. OPERATIONAL CONSIDERATIONS

A simple way to effect an indirect-fire kill is to use a laser in the hands of special operators in the fire area to trigger a kill indication in the MILES system at the target. This concept requires only a very limited number of operators for the mechanized infantry battalion-versus-battalion exercise. Appendix I deals with the deployment and use of the laser designator.

The simulation fire message from the Net Control Station (NCS) includes weapon code number (which identifies the pulse code format), weapon caliber and/or kill area dimensions and target coordinates. The latter may be range and bearing when the operator's position is known by the NCS but could also be grid coordinates (in which case the operator can visually identify the target point and determine range, either by map or estimation, or he can calculate range and bearing from his known position). Therefore, essential data can be set into the laser as required.

The operator will always seek out the best vantage point to achieve clear line-of-sight to target. An elevated position is desired to minimize terrain masking and produce the desired kill area "footprint" on the ground.

In addition to kill designation in a limited area, the laser can also signal a near miss over a larger area. A special code can trigger an indirect fire audio signal at the MILES target, requiring only the addition of an audio generator and simple cue signal decoder to MILES.

B. OPERATIONAL REQUIREMENTS

Operation within a company-size area and consideration of increased masking at long ranges indicates that 1 km is a reasonable maximum range requirement. Masking forces consideration of short ranges, say 0.1 km.

A desirable goal is to achieve the above ranges in weather where the target point is just visible. However, it will be seen that this is a design problem when coupled with an eye-safe laser of reasonable dimensions.

The weapons to be simulated are high explosive/fragmentation rounds (impact and air burst HE) from 81 mm and 4.2 in. mortars and from 155 mm and 8 in. howitzers, plus Improved Conventional Munitions (ICM) such as multi-bomblet rounds from the 155 mm and 8 in. howitzer. The maximum lethal diameter (considering the equivalent circular area for unity kill probability) for these rounds occurs for exposed, standing troops and is given in Table C-1.

The laser must be capable of simulating single round or volley fire. The maximum number of rounds in a volley equals the number of tubes in the mortar platoon or howitzer battery as indicated in Table C-2. The volleys may be delivered in the normal parallel sheaf or in a converged sheaf or open sheaf as defined in Table C-2. Massed fire of several howitzer batteries will be considered to fall in the same area as that for the single battery.

The laser must produce a minimum of nine unique pulse codes in the MILES code set to accommodate the following indirect fires:

- Single round HE
 - Impact burst
 - Airburst
- Single round ICM
- Volley HE
 - Impact burst
 - Parallel sheaf
 - Converged sheaf
 - Airburst
 - Parallel sheaf
 - Converged sheaf
- Volley ICM
 - Parallel sheaf
 - Converged sheaf

Appendix N discusses the decoding of these codes at the target to produce the correct kill probability (P_k).

Table C-1. Single Round Lethal Diameter
(Against Exposed Troops)

| Round | Lethal Diameter (~ meters) |
|----------------------|-------------------------------|
| 81 mm HE, airburst | 16 |
| 4.2 in. HE, airburst | 21 |
| 155 mm HE, airburst | 32 |
| 8 in. HE, airburst | 40 |
| 155 mm ICM | 106 |
| 8 in. ICM | 158 |

Table C-2. Volley Fire

| Weapon | Parallel Sheaf | Converged Sheaf | Open Sheaf |
|---------------|----------------|-----------------|--------------|
| 3 ea. 81 mm | 100 m x 50 m | 50 m x 50 m | 200 m x 50 m |
| 4 ea. 4.2 in. | 200 m x 50 m | 50 m x 50 m | 300 m x 50 m |
| 6 ea. 155 mm | 300 m x 200 m* | ** | 250 m x ** |
| 4 ea. 8 in. | ** | ** | 240 m x ** |

*Nominal area of battery emplacement.

**Data not available.

The kill area for single rounds is a function of the code (that is, type and fuzing) and caliber of the round. The kill area can be implemented as an equivalent circle or square of dimensions consistent with the P_k level chosen. For volley fire it should be adequate to limit sheafs to the parallel and converged cases. The sheaf coverage varies with caliber and number of rounds. Converged sheaf coverage can be adjusted to be consistent with assigned round P_k .

Therefore, the laser must be capable of producing varying kill coverage. Manual setting of kill width and depth is indicated for the more numerous conditions of volley fire, but automatic setting for single rounds is desirable. A reasonable simulation is to produce the coverage relative to the laser sighting azimuth (as opposed to the weapon firing azimuth).

The kill volume must also consider target heights of 0 to 2 meters (prone or standing troops, vehicles, and the like).

Near miss cueing should cover the kill area plus an appropriate additional area. A reasonable value is an additional ± 100 m in width and depth.

The laser must produce the MILES 40×10^{-6} W/cm² detection level signal at the desired range and be eye safe at all ranges.

Optional hand-held or tripod operation is desired.

The battery pack must be replaceable in the field and should be sized to support a heavy fire engagement of the two mechanized infantry battalions in the exercise.

The ammunition load for each mortar and howitzer is about 150 rounds. Considering the most probable case of salvo fire by each mortar platoon and each howitzer battery, the maximum number of salvos per battalion for a heavy fire engagement is:

| | |
|---------------|---------------------------------------|
| 150 x 3 = 450 | for the 3-81 mm mortars |
| 150 x 1 = 150 | for the single 4.2 in. mortar platoon |
| 150 x 2 = 300 | } for the 2 to 3 howitzer batteries |
| x 3 = 450 | |

900 to 1050 total salvos per battalion

Appendix I discusses the use of 5 laser operators per battalion. The average number of salvos per operator for this worst case fire situation is:

$$\frac{900 \text{ to } 1050}{5} = 180 \text{ to } 210 \text{ salvos per operator.}$$

Therefore, the laser battery should provide 200 simulation missions.

Night operation must be considered. Obviously a night vision device is required at night and can be treated as an attachment.

Extension to use in a helicopter should be considered for increased mobility and vantage point.

C. DESIGN CONCEPT

The design concept is shown in Figures C-1 and C-2.

A laser design which is eye safe at all ranges restricts power output to relatively low level (when compared with megawatts available from Nd:YAG lasers). This consideration, plus the need for high pulse rate and lightest possible weight, indicates the use of a GaAs (gallium arsenide) diode laser.

The low power also restricts beam size at the target to small dimensions compared with area fire requirements, and this in turn indicates the need for beam scanning to cover the required kill/cue areas.

To maintain maximum possible beam size at the target, in order to minimize scan time, requires beam "zoom" control. Also, a high power GaAs source is necessary to produce the largest possible beam size in order to minimize scan time for the larger areas. A uniform extended source of eye safe radiance is produced with an optical integrator. Use of an adjustable iris at the source also allows smaller beam selection when required for small area/low aspect situations.

Scan control is complicated by variable laser height above the target area; -- that is, the greater the height, the larger number of elevation scan bars required to cover the kill area. Also, at the low aspect angles to be encountered, the angular extent of elevation scan is not symmetrical about the center aim point.

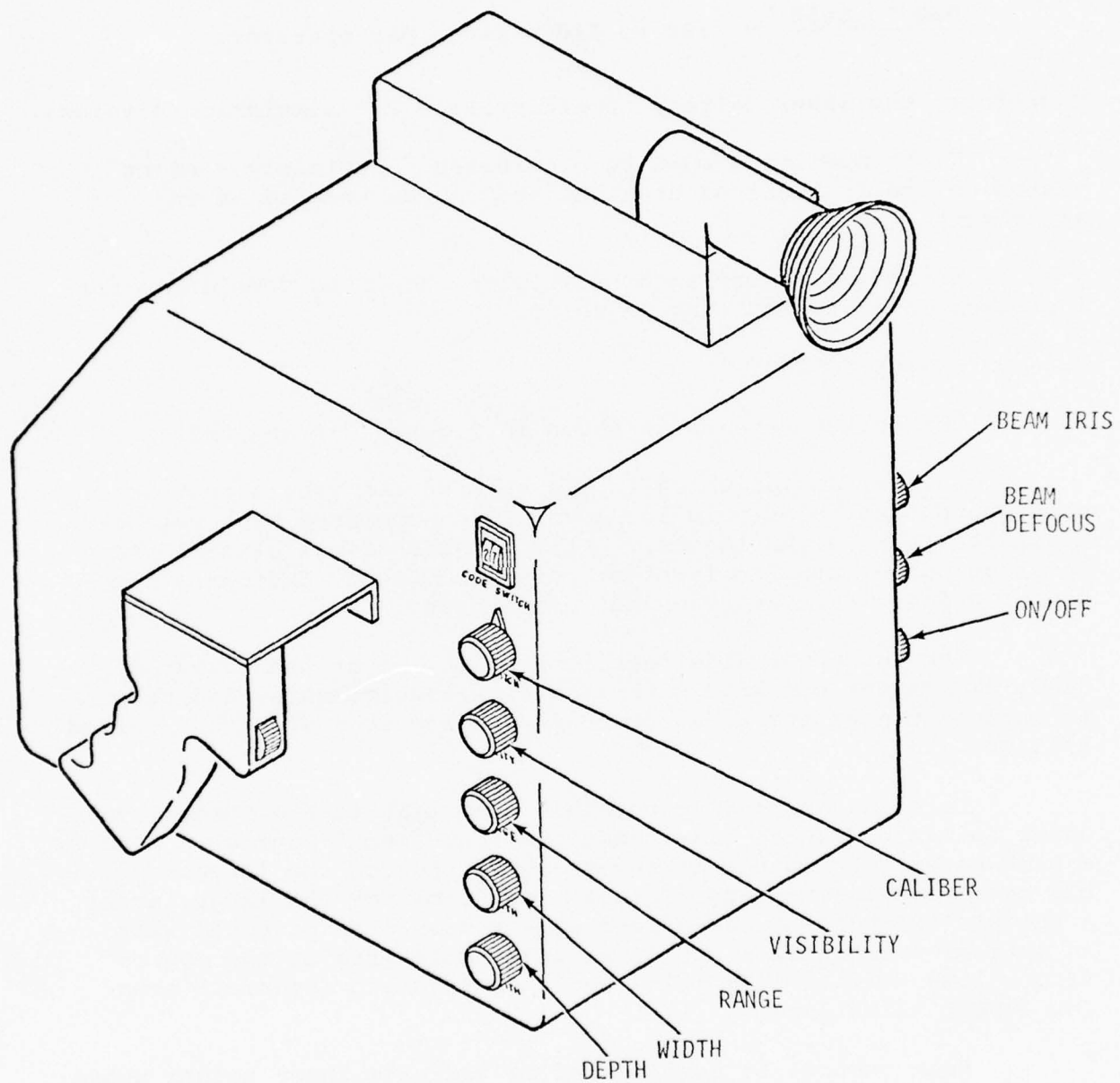

PICTORIAL DRAWING

P3254

Figure C-1. Laser Weapon Simulator (Sheet 1 of 3)

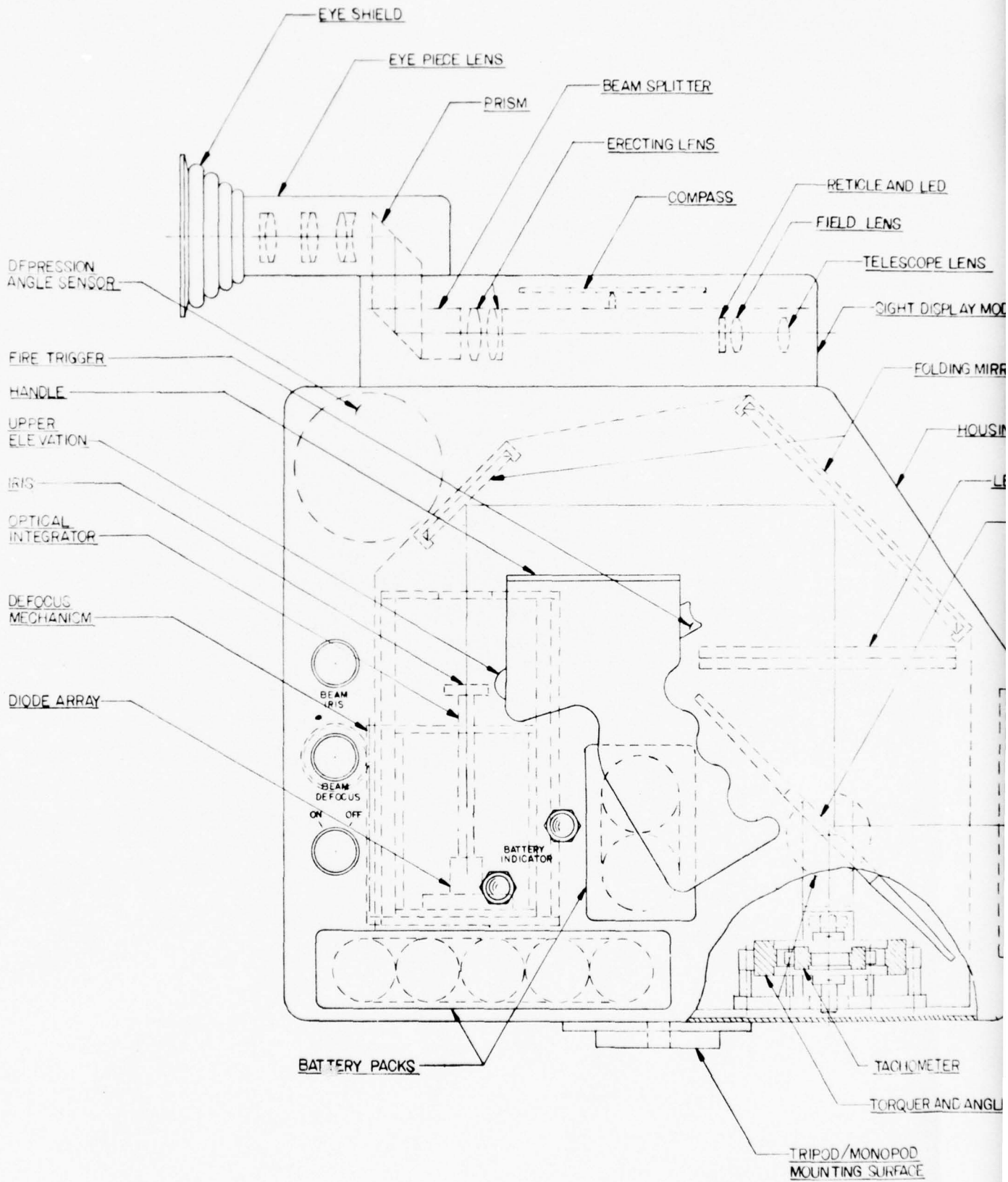

RIGHT SIDE VIEW

Figure C-1. Laser Weapon Simu

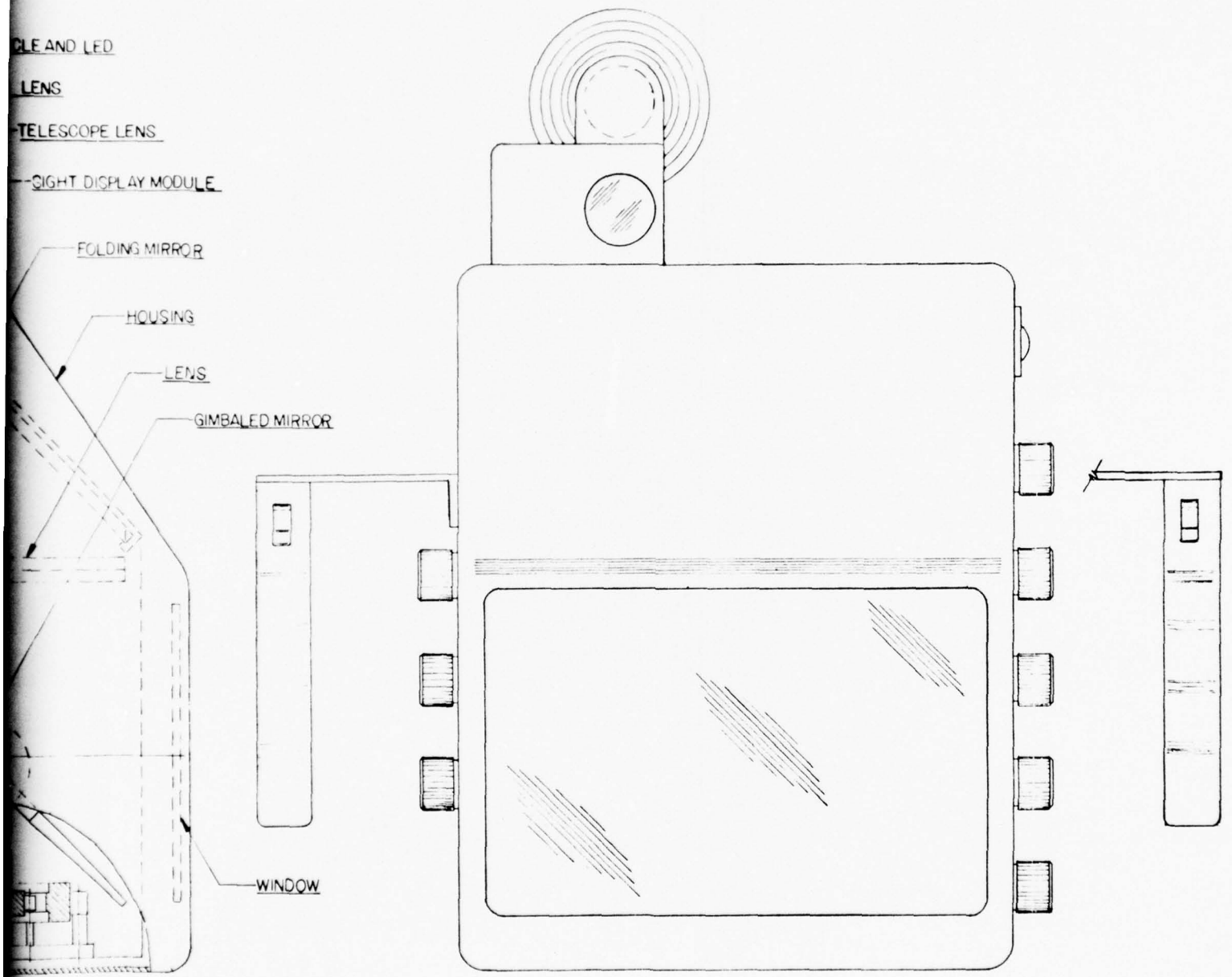

ANGLE AND LED

LENS

TELESCOPE LENS

SIGHT DISPLAY MODULE

FOLDING MIRROR

HOUSING

LENS

GIMBALED MIRROR

WINDOW

FRONT VIEW

TACHOMETER

TORQUER AND ANGLE PICKOFF

MONOPOD
SURFACE

SK101058

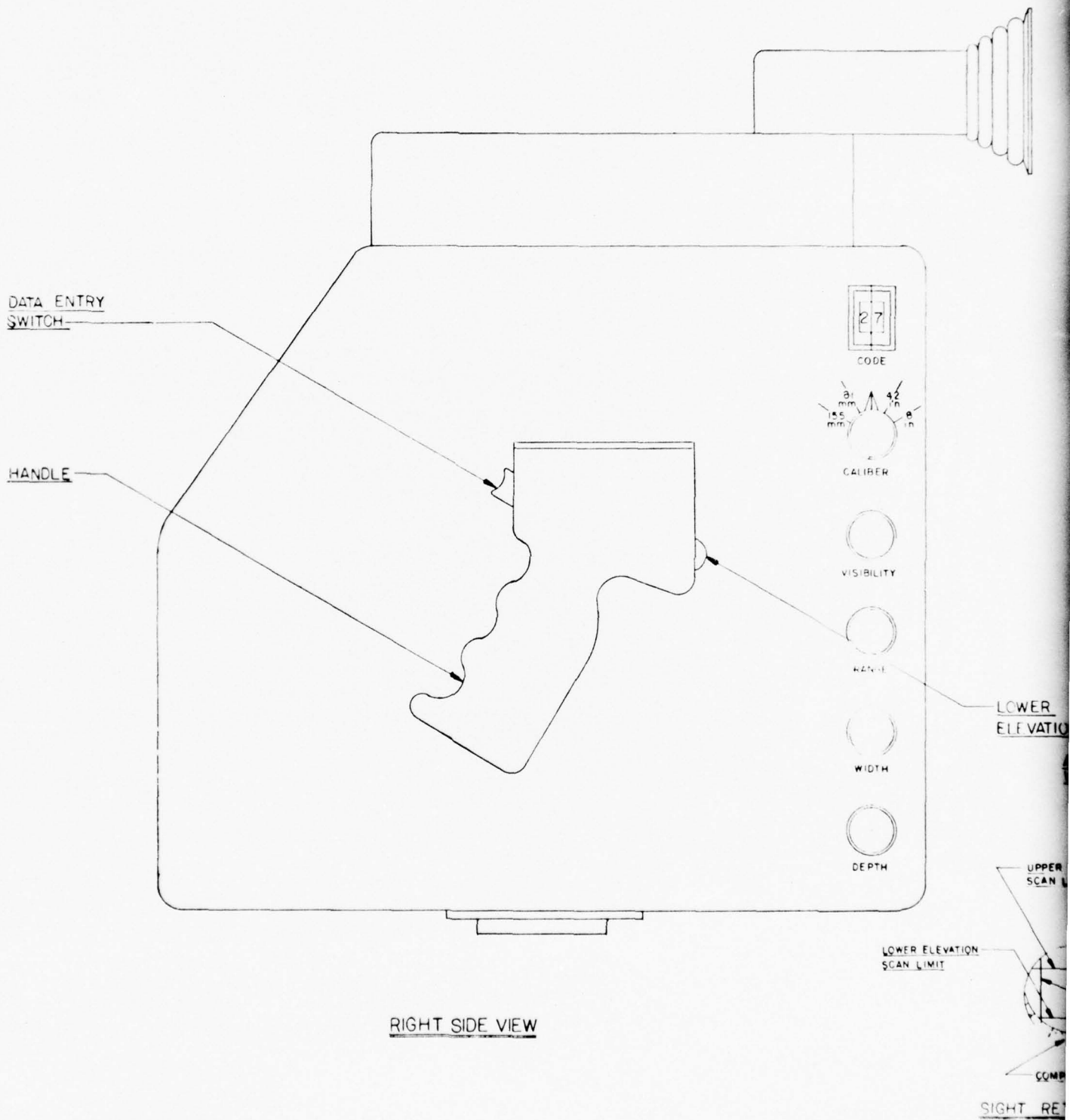
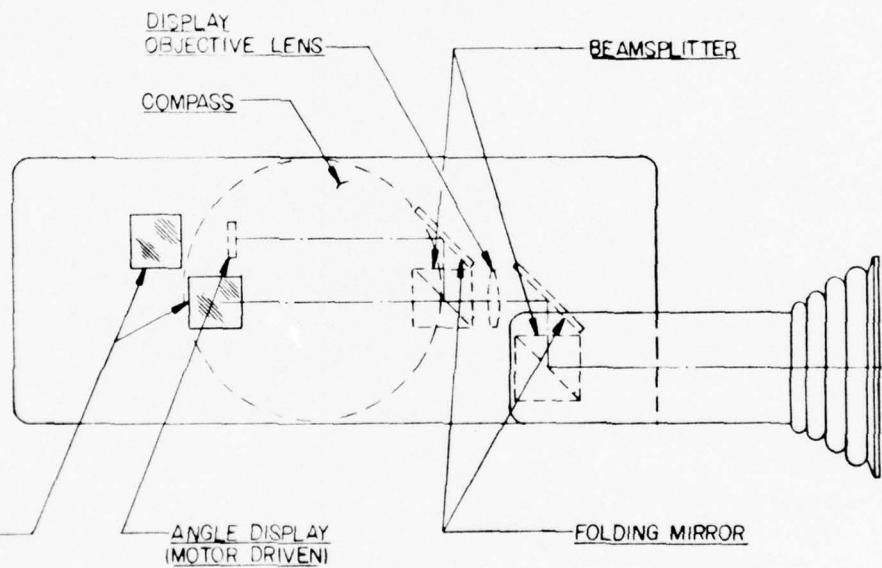
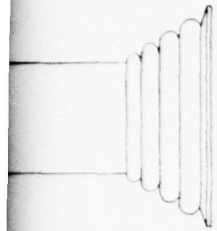
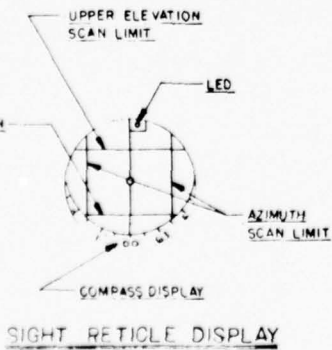

Figure C-1. Laser Weapon Simu

| NO. | DESCRIPTION | LOCATION |
|-------|---|----------------------|
| PCB 1 | LASER DRIVER | DEFOCUS MECHANISM |
| PCB 2 | MICROPROCESSOR AND INTERFACE | LEFT SIDE OF HOUSING |
| PCB 3 | GIMBAL DISPLAY, SERVO DRIVE AND | LEFT SIDE OF HOUSING |
| PCB 4 | LOW VOLTAGE POWER SUPPLY PULSE CODE GENERATOR AND 200 VOLT POWER SUPPLY | REAR OF HOUSING |



TOP VIEW OF SIGHT DISPLAY



SIGHT RETICLE DISPLAY

SK101058

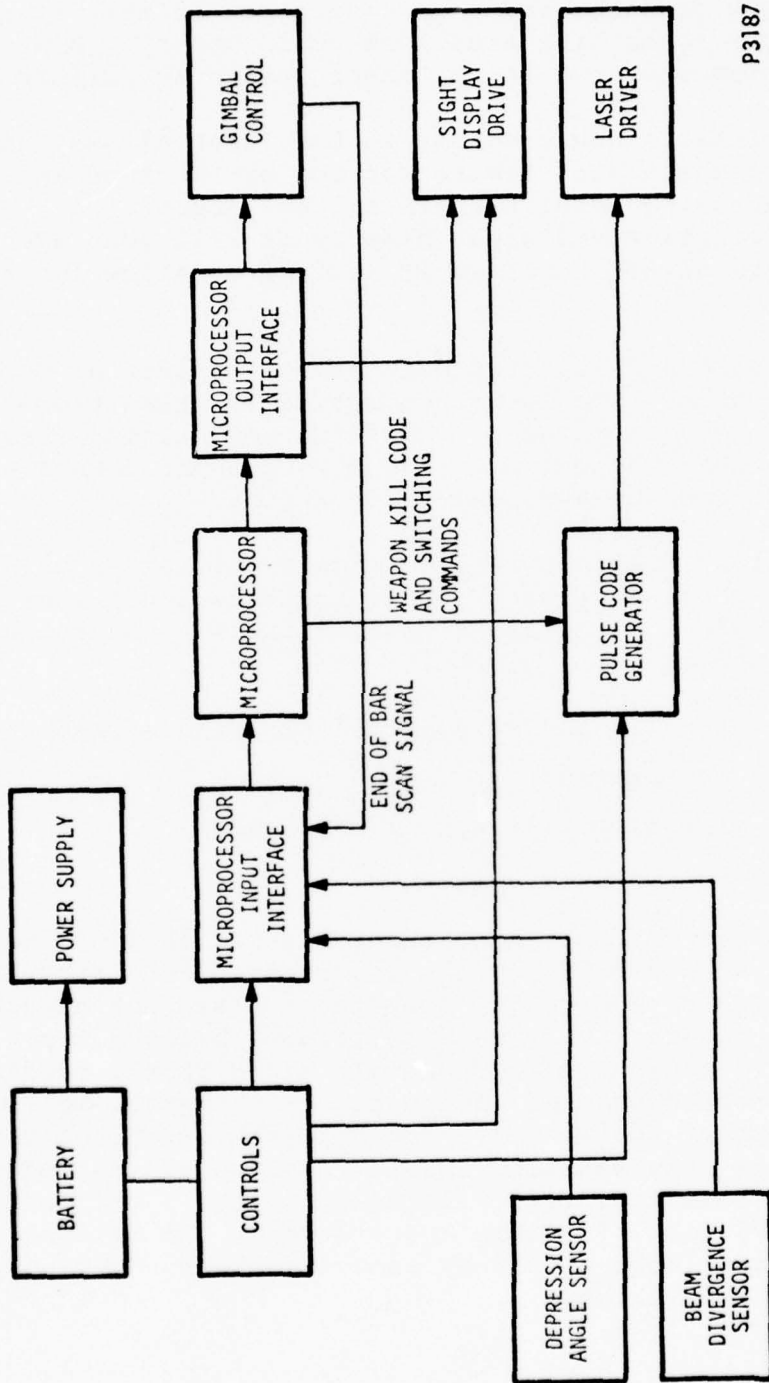

P3187

Figure C-2. Indirect/Area Fire Simulation System Electronic Block Diagram

The advent of the microprocessor has made it feasible to produce optimum scanning and beam divergence as well as perform code and single round kill area look-up in memory. A microprocessor is incorporated in the laser design to perform the tasks.

A depression angle sensor in the laser allows automatic setting of elevation scan limits for the given range and kill (or cue) depth, assuming level terrain in the target area. In addition, manual override and sight display of kill scan area allow the operator to adjust coverage if desired to allow for terrain variation.

Kill scan and selected code pulsing starts at depression of the fire button. The laser automatically transitions to cue scanning and cue code pulsing. Scanning and pulsing terminate automatically when the cue area has been scanned. Each new mission is preceded by a manual reset action.

The sight does not require magnification for this mission, which is also consistent with achieving wide angle viewing necessary for viewing the laser scanned areas at short range. The sight includes:

- Sighting cross-hairs and stadiametric ranging marks;
- Magnetic compass bearing;
- Azimuth and elevation kill scan limits; and
- Lasing indicator.

The weight of the laser exceeds the 2 lb limit normally associated with hand-held devices (such as, binoculars) and the configuration shape and weight distribution are not amenable to a shoulder configuration (such as, rifle or bazooka type). The selected configuration is a moderately sized "box", carried and aimed with attached handles, and using an integral, telescoping monopod to support the weight. The moderate weight of the laser (10 lb) permits easy handling and fast set-up of the monopod. A headrest is used to enhance aiming stability. Utilization should be easy, fast, flexible and accurate. An optional tripod mode is also available simply by removing the monopod and attaching the laser to a tripod.

D. LASER DESIGN

1. GaAs Source

Analysis has shown that a 1 kW pulsed GaAs source is required to achieve satisfactory scan time for the large area, volley fire simulation. This is the most powerful source available from the leading supplier of GaAs diode lasers, Laser Diode Laboratories. This source consists of an array of 110 diodes as described in the data sheet of Figure C-3. Figure C-4 shows the source configuration.

To produce a circular, uniformly emitting source, a clad glass rod will be added to the configuration of Figure C-4. The rod will have a diameter of 0.260 in. to match the source diagonal of 0.255 in. and allow some positioning tolerance. Rod length will be 2.6 in. By means of total internal reflection this optical integrator spreads the source energy evenly over the exit face and also produces a symmetrical radiation pattern. (The integrator preserves the input angle of each ray relative to the face normal, but can rotate it to any position about the normal; in this manner rotational mixing of the inherently non-symmetrical GaAs radiation pattern produces a symmetrical pattern.)

2. Beam Forming Optics

a. Optimization

The requirement is to produce $40 \times 10^{-6} \text{ W/cm}^2$ at the designated range. The governing equation is:

$$(P_s K \epsilon_1 T_o T_A) / [\pi/4 (R\alpha)^2] = 40 \times 10^{-6} \quad (1)$$

where

P_s = source power = 10^3 W

K = derating factor for high PRF and high temperature
= 0.64 (See Figure C-4 for maximum rating PRF and
 $T_c = +55^\circ\text{C}.$)

ϵ_1 = power collecting efficiency of the optics (see
Figure C-5), including f/10 central masking for eye
safety (see paragraph D.2.d)

| | | |
|-----------------------|--|------------|
| PACKAGE: COPPER BLOCK | CLASS: GaAs Hetero Structure Laser Diode Array | TYPE LD410 |
|-----------------------|--|------------|

DESCRIPTION: Room temperature GaAs laser diode array mounted on copper heat sink which is designed to interface with a flat surface. The copper heat sink can be tailored to particular system size requirements. Isolated electrical terminals are provided on the heat sink. The five port array consists of 110.9 mil GaAs laser diodes in 10 parallel 11 diode strips assembled in a V staircase on the heat sink. The source depth is .240 inch.

| CHARACTERISTICS: $T_c = 27^\circ\text{C}$; $f = 1\text{ KHZ}$; $t_p = 130\text{ ns}$ | Min. | Typ. | Max. | Units |
|--|------|-----------|------|---------|
| Peak Power Output at $I_{FM} = 40\text{ amp}$ (P_{pk}) | 1000 | 1150 | | W |
| Threshold Current (I_{th}) | 6 | 10 | 20 | A |
| Forward Voltage at I_{FM} (V_F) at 50 ma | | 150 27 | | V V |
| Emission Wavelength (λ) | | 905 | | nm |
| Spectral width between 50% Peak Intensity Points | | 2.5 | | nm |
| Half Angle Between 50% peak beam intensity points Plane normal to junction | | 8 | | degrees |
| Plane parallel to junction | | 7 | | degrees |
| Emitting Area | | 170x190 | | mils |

MAXIMUM RATINGS:

| | |
|---|-------------------|
| Peak forward current at $T_c = 27^\circ\text{C}$ (I_{FM}) | 40A |
| Max. Pulse Duration at $T_c = 27^\circ\text{C}$ T_{pm} | 200 ns |
| Repetition Rate at $T_c = 27^\circ\text{C}$, I_{FM} , T_{pm} | 1 KHZ |
| Duty cycle at $T_c = 27^\circ\text{C}$ | 0.02% |
| Storage Temperature range | -196°C to + 100°C |
| Operating Temperature range | -196°C to + 75°C |

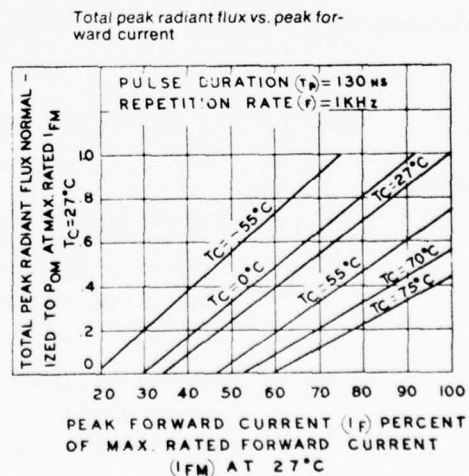
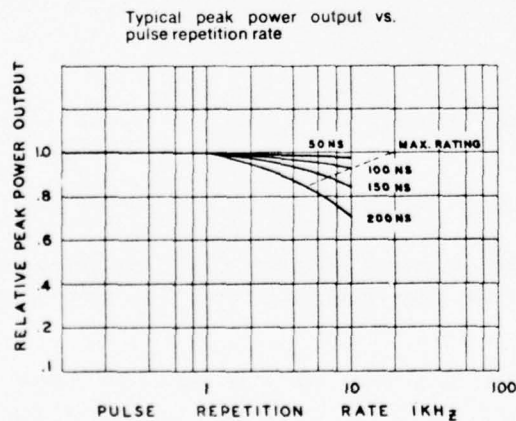
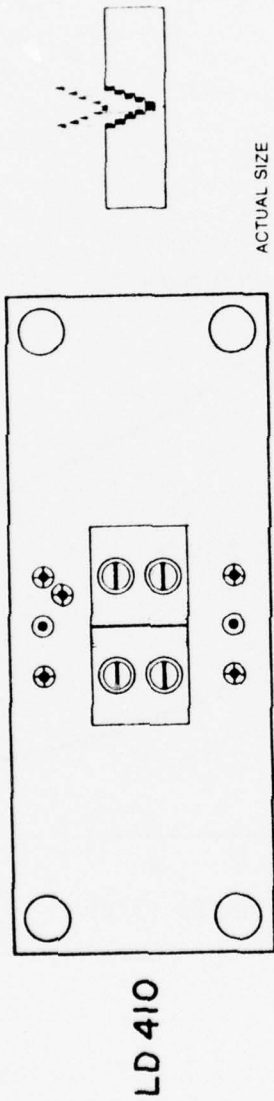
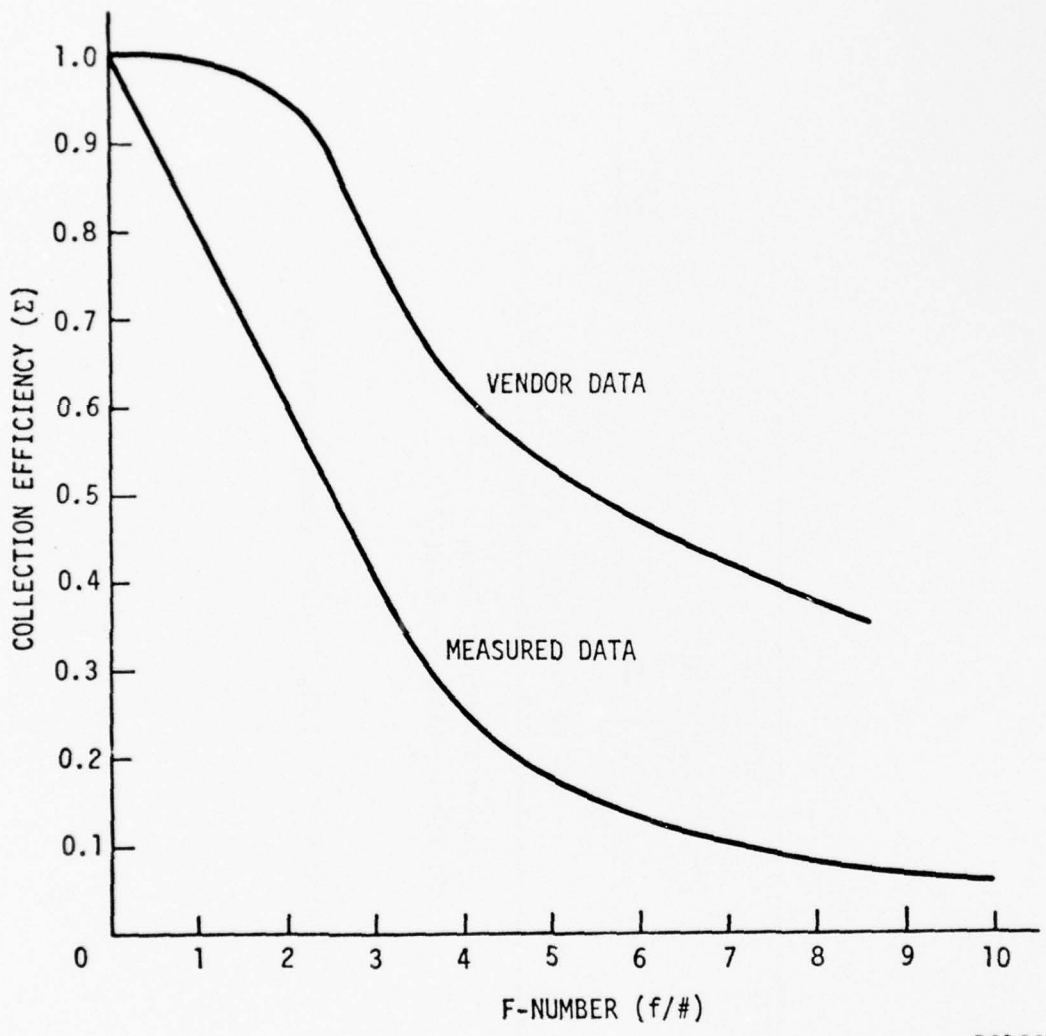

Figure C-3. GaAs Source Characteristics



- ⊕ INDICATES POSITIVE TERMINAL
- ⊙ INDICATES COMMON TERMINAL

Figure C-4. GaAs Source Configuration



P3189

Figure C-5. Optical Collection Efficiency for Laser Diode Radiation Patterns

T_O = optical transmission = 0.83 (see Table C-3)
 T_A = atmospheric transmission
 R = range ~ cm
 α = beam divergence ~ radians
 = $d/f = d/D(f/\#)$
 d = source diameter
 f = lens focal length
 D = lens aperture diameter
 $f/\#$ = f/D

Table C-3. Optical Transmission

| | |
|---------------------|-------------|
| Optical Integrator | 0.96 |
| Folding Mirrors (2) | 0.96 |
| Lens | 0.96 |
| Gimbaled Mirror | 0.98 |
| Window | <u>0.96</u> |
| Total | 0.83 |

The resulting performance equation can be written:

$$\begin{aligned}
 R^2/T_A &= (13.28 \times 10^3) M_S D^2 \epsilon_1 (f/\#)^2 \\
 &= 38.76 \times 10^6 D^2 \epsilon_1 (f/\#)^2
 \end{aligned}
 \tag{2}$$

where

$$\begin{aligned}
 M_S &= \text{source power density} \\
 &= P_S / (\pi/4 d^2) = 2919 \text{ W/cm}^2
 \end{aligned}$$

To maximize performance, the above equation shows that the term D^2 and $\epsilon_1 (f/\#)^2$ must be maximized.

The lens aperture diameter, D, is constrained by the desire for a reasonable hand-carried and hand-aimed configuration. A realistic maximum is:

$$D = 4 \text{ in.} = 10.16 \text{ cm}$$

The power collecting efficiency (ϵ) of the optics is a function of f/# as shown in Figure C-5. This figure was obtained from actual measured data for single junction, 3-junction and 4-junction GaAs sources, all in close agreement. Note that the data are more conservative than vendor data. The value of $\epsilon_1 (f/\#)^2$ is shown in Figure C-6 as a function of f/#. This figure shows that an f/# of 3 to 4 provides optimum performance. The smaller f/# results in the smallest configuration and largest infinity-focused beam divergence (for fast scan). Therefore, the selected value is f/# = 3, resulting in:

$$\epsilon_1 (f/\#)^2 = 3.1$$

The optical integrator described in paragraph D.1. provides better than f/3 collection of the 1 kW GaAs power, and therefore the f/3 lens collection efficiency is the limiting factor.

The performance equation (2) therefore becomes:

$$R^2/T_A = 1.24 \times 10^{10} \text{ cm}^2 \quad (3)$$

For the 0.9 μm wavelength, atmospheric attenuation is given by¹:

$$T_A = e^{-2.4 R/V_{1.0}}$$

where $V_{1.0}$ = visible range of 100% contrast objects (against sky background). For the desired $V_{1.0} = R$, $T_A = 0.0907$. In that case:

$$\begin{aligned} R^2 &= 0.112 \times 10^{10} \text{ cm}^2 \\ R &= 0.33 \text{ km} \end{aligned}$$

¹McClatchey, et al., "Optical Properties of the Atmosphere", AFCRL, AD-753075, Aug. 1972.

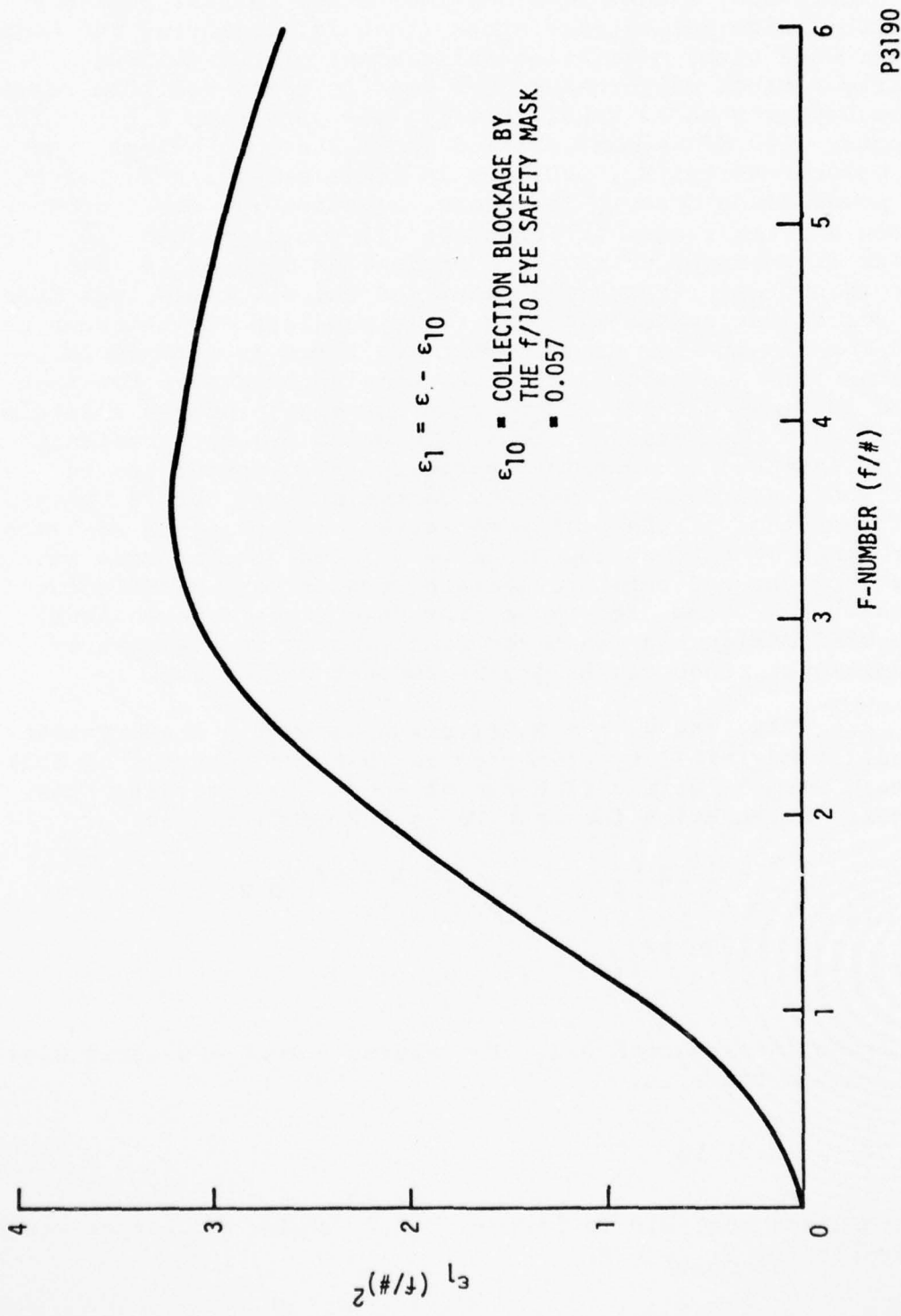

P3190

Figure C-6. Optics Optimization Curve

Therefore, a GaAs laser optimized for fastest possible scan of the large volley fire areas (that is, employing the highest power GaAs array available) falls short of the desired visibility-limited performance at 1 km. In fact, the 1 km range requires better than 10 km visibility (see paragraph E.2.). If a lower power (100 W maximum) stacked diode laser were used, the source power density, M_s , would be 10 times greater than for the higher power diode array. Therefore, equation (3) would produce $\sqrt{10}$ times greater range, but equation (1) would produce $\sqrt{10}$ times less beam divergence, which would produce as much as 10 times greater scan time. (This is a result of the $\sqrt{10}$ times less beam height for elevation bar scan and $\sqrt{10}$ times less azimuth scan rate allowed for the smaller beam.) That is, there is a tradeoff between scan time and range. But even more important is the fact that the 10 times greater source power density produces a single pulse radiance that exceeds the single pulse eye safe radiance level for extended sources (see paragraph E). Therefore, in actuality the source power density cannot be more than 3 times greater than that of the high power array, resulting in $\sqrt{3}$ times greater range at the expense of up to 3 times greater scan time (and because the eye safety criterion becomes more restrictive with longer scan time, the range improvement can be even less). The selected design has minimized scan time at the expense of some additional range capability in reduced visibility.

Actually, the $V_{1.0} = R$ criterion is overly conservative. A more realistic visibility criterion is that the operator be able to discern normal terrain features of about 25% contrast. The atmospheric attenuation for this $V_{0.25} = R$ condition is:

$$\begin{aligned} T_A &= e^{-2.4 R/V_{1.0}} = e^{-2.4 R/1.54 V_{0.25}} \\ &= e^{-1.56 R/V_{0.25}} = 0.21 \end{aligned}$$

as discussed in paragraph E.2. Therefore, a more realistic visibility-limited range is:

$$R = 0.51 \text{ km}$$

The performance analysis in paragraph E.2. shows the longer ranges which result for $V_{0.25} > R$.

Summarizing, the optimum optical design is:

Aperture = $D = 4$ in.

Focal length = $f = D(f/\#) = 12$ in.

b. Beam Adjustment

When the laser is infinity-focused (optical integrator exit face at the focal plane), the beam divergence is:

$$\alpha = d/f = \frac{0.260}{12} = 0.0216 \text{ radian} = 1.24^\circ$$

This produces a beam diameter of 21.6 meters at 1 km range. This large beam diameter is desired for fast scan of the large areas associated with artillery volley fire. However, at short ranges the beam diameter becomes small.

To permit a larger beam at short range the laser employs defocusing. This is achieved by moving the source toward the lens. Figure C-7 shows how the collection angle of the optics defines an apparent source diameter at the focal plane which defines the beam divergence angle. Symmetry of the source radiation pattern ensures a circular apparent source and therefore a circular beam.

Equation (1) shows that maximum allowable beam diameter ($R\alpha$) at any range is determined by visibility (actually T_A). To provide the minimum scan time permitted by visibility, the microprocessor calculates the maximum defocus setting for input visibility and range. The operator manually sets defocus to extinguish an indicator in the sight. If a smaller beam is required for kill area definition, the microprocessor also solves for that condition, and the indicator will not extinguish until that condition is met. If the beam must be less than 0.0216 radian, an iris provided at the optical integrator exit face is brought into play (after minimum defocus setting has been reached without extinguishing the sight indicator).

c. Beam Power Density Distribution

The focused condition produces uniform beam power density because the source is uniform. However, the defocused condition produces non-uniformity. As indicated in Figure C-7, each radiating point of the actual source becomes a blur circle at the apparent

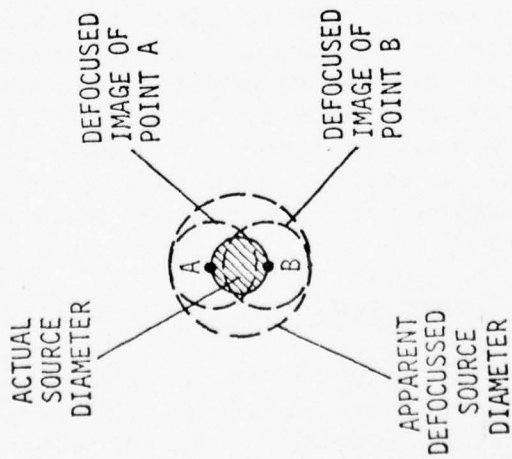
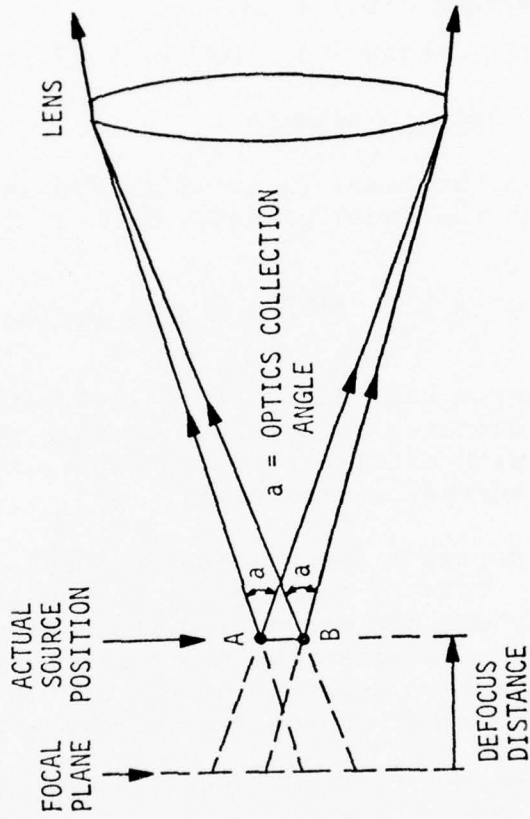
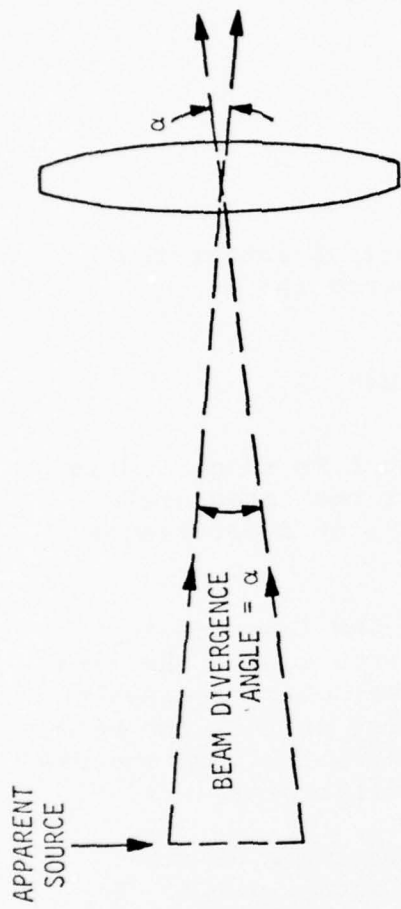

P3191

Figure C-7. Defocusing to Produce Large Beam Divergence

defocused source. The resulting power density distributions of the apparent source for several defocus conditions are shown in Figure C-8a. (These are first order approximation for uniform beam pattern.) The power density of an equivalent uniform source having the same diameter as the actual apparent source is shown in Figure C-8b for two defocus conditions. The effective diameter of the actual apparent source is seen to be approximately 70% of the actual diameter; that is, the effective beam divergence in the defocus condition is only 70% of the full beam divergence.

d. Lens Selection

A single spherical surface lens is limited by spherical aberration to a blur angle of:

$$\beta = \frac{0.067}{(f/\#)^3} \text{ radians} = 2.48 \text{ mr, for } f/3$$

A doublet lens can reduce this by a factor of 5:

$$\beta = 0.5 \text{ mr}$$

The latter is consistent with the smaller beam requirements as well as good defocused beam definition. Therefore, a glass doublet lens will be used.

Several alternatives were considered. Aspheric Fresnel lenses have been investigated for GaAs light collimation in the past and were found to produce an undesirable coarse ring pattern. Plastic lenses have borderline quality when good blur performance is desired at f/3 and 4 in. aperture. A spherical mirror is a suitable alternative, but requires greater packaging volume.

The optical path is folded as shown in Figure C-1 to achieve a good laser configuration.

For positive eye safety the central 10% of the lens is masked, making it impossible to see the GaAs diode junctions directly through the f/10 optical integrator. Only the uniform power density at the integrator exit face could be seen by an eye at the lens.

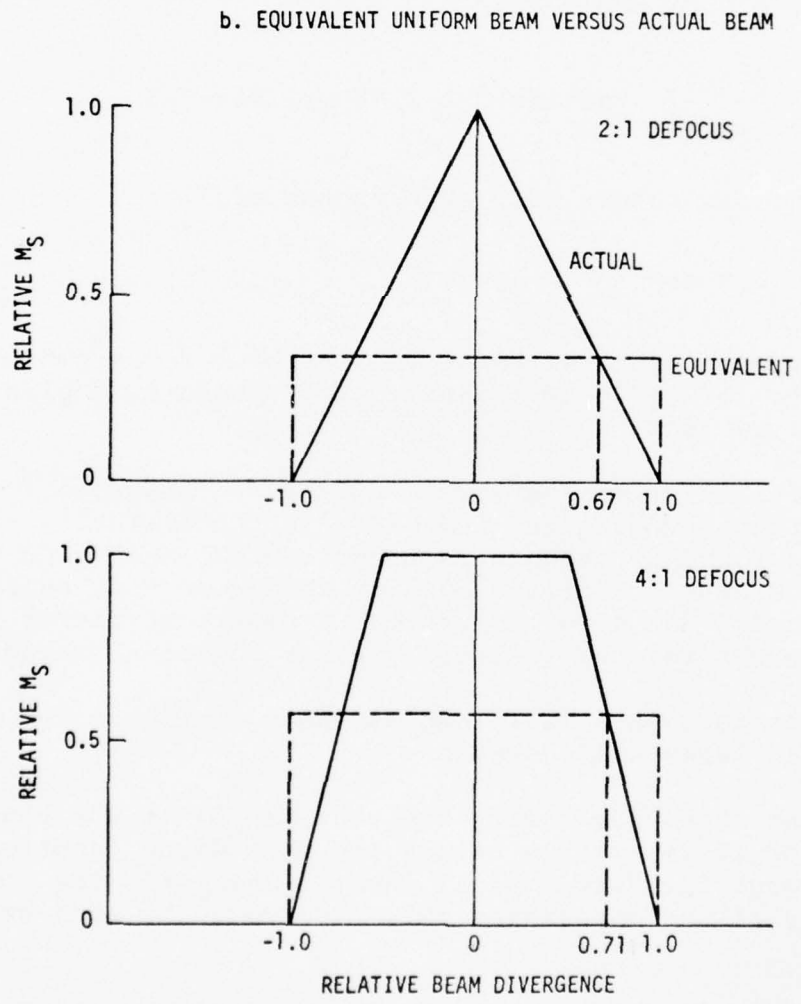
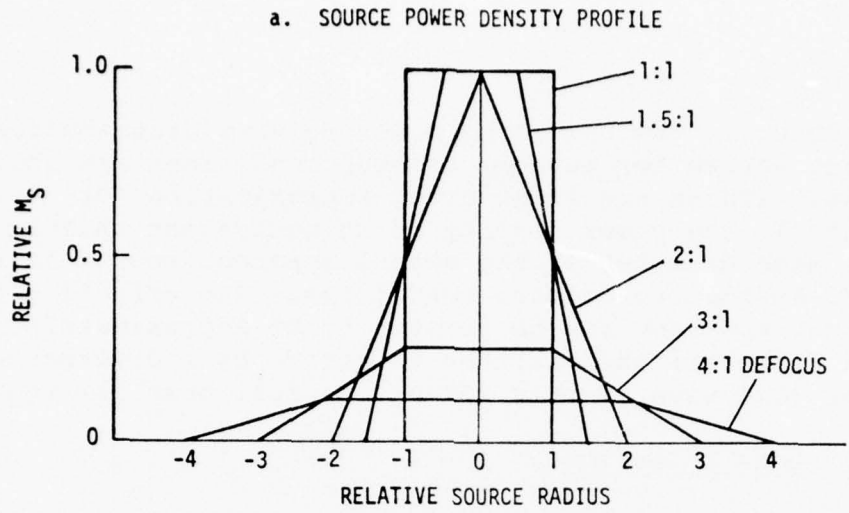

P3192

Figure C-8. Defocused Power Density Distributions

3. Gimbaled Mirror

Scanning of the laser beam is achieved with a gimbaled mirror as shown in Figure C-1. The outer gimbal provides the large azimuth scanning required for volley fire, while the inner gimbal provides the limited elevation scanning required by the low aspect angles. Note that the conical beam produced for all source defocus and iris settings is immune to the optical axis rotation produced by the azimuth scan.

The gimbal incorporates DC torquers and potentiometer pickoffs in each axis to achieve position control. In addition, the azimuth axis incorporates a tachometer to provide rate feedback.

Mechanical caging is not necessary. Soft stops are provided in each axis to prevent damage while transporting, and the permanent-magnet torquers are short-circuited to provide heavy damping.

4. Electronics

The top level electronics block diagram is shown in Figure C-2.

a. Controls

The controls are shown in Figure C-9 and the configuration drawing of Figure C-1. Control operation is as follows:

- (1) Set weapon code on the code thumbwheel switches.
- (2) Set weapon caliber on the caliber switch (for single rounds only).
- (3) Set target range on the range potentiometer.
- (4) Set kill area dimensions on the volley kill width and depth potentiometers (for volley fire only; for single rounds, set potentiometers to "single round", that is, zero position).

NOTE: The above four commands, plus the target azimuth (or target grid coordinates), constitute the fire message from the FDC.

* DENOTES OPERATOR CONTROL

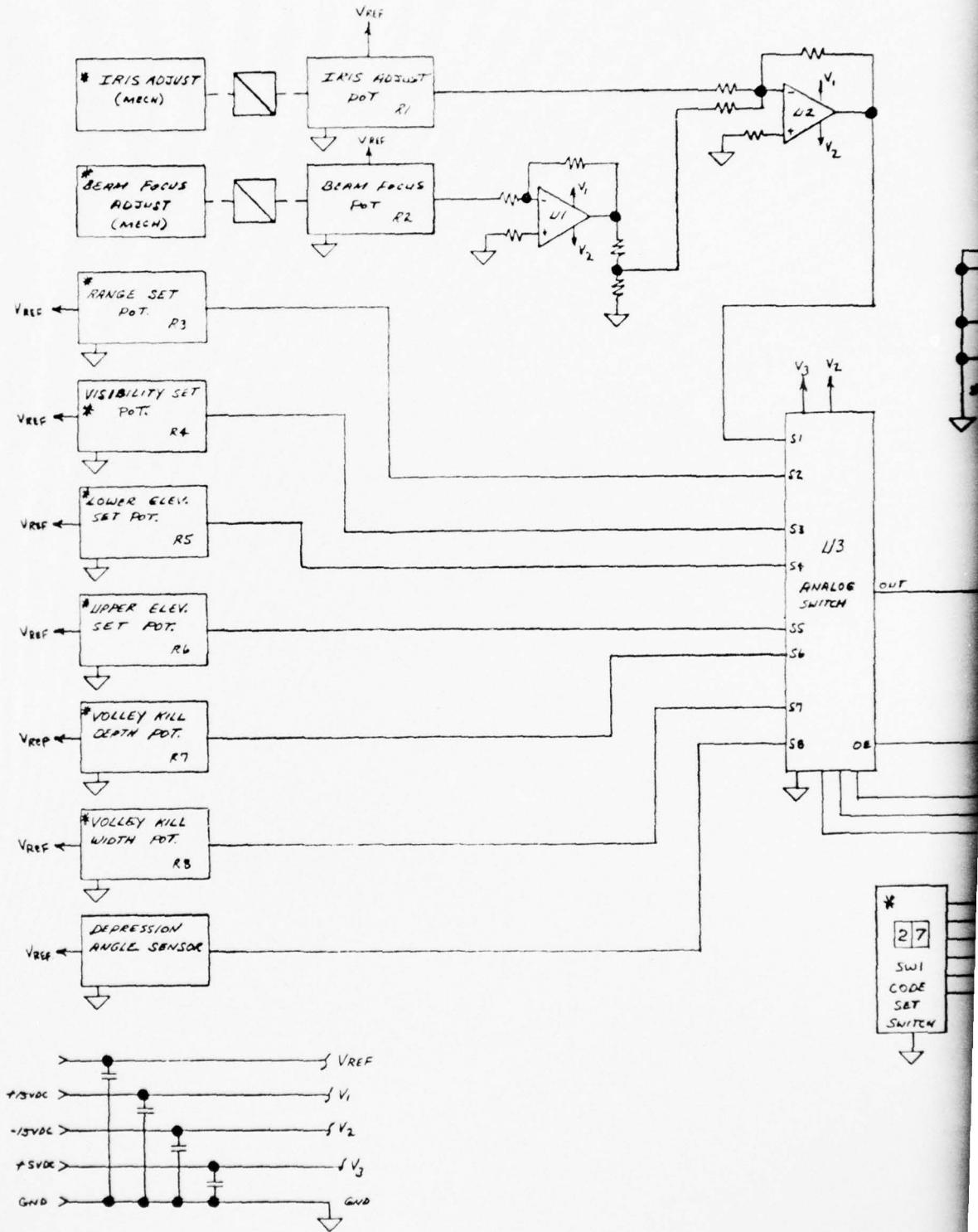
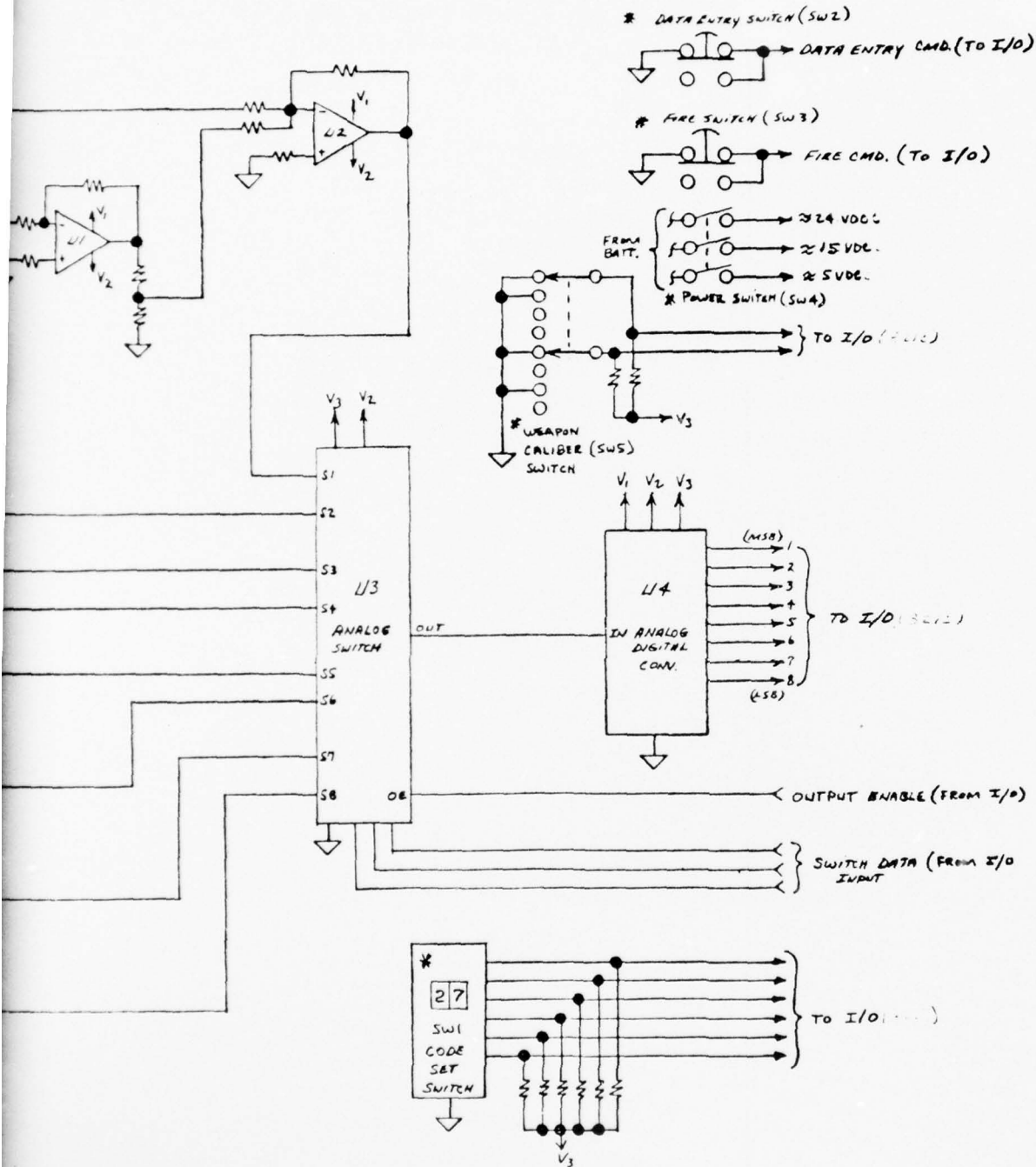

Figure C-9. Controls and Input Interf (Indirect/Area Fire Simulator System)



P3257

- (5) Approximate visibility is set on the visibility potentiometer (will normally require only periodic update).
- (6) Verify that the beam iris control is set to maximum and that the elevation scan angle thumbwheel potentiometers are in the center detent position.
- (7) Switch power on when ready to sight.
- (8) Using the sight compass display, aim the laser at the assigned azimuth and at a ground point whose estimated range is the assigned range (or aim the laser at an identified grid coordinate point).
- (9) Press the data entry switch. (This allows the micro-processor to solve for optimum beam size and scan angles.)
- (10) Adjust the beam defocus control to extinguish the sight indicator. (This sets the maximum possible beam size allowed to maintain required signal power density at the target range.) If the indicator does not extinguish for minimum setting of the large beam control, remain at minimum setting and shift to the beam iris control, adjusting until the indicator extinguishes. (This sets the maximum beam size consistent with single scan bar coverage of the kill area.)
- (11) If the elevation kill-scan coverage displayed in the sight does not look correct because of target area terrain slope or terrain variations, the upper and lower elevation limits can be adjusted independently with the thumbwheel elevation control potentiometers.
- (12) Establish precise aiming on the target point and depress the fire switch. Maintain aiming and fire switch depression until the pulsing sight indicator extinguishes.

b. Beam Divergence Sensor

Beam divergence angle is given by:

$$\begin{aligned}\alpha &= \alpha_I + \alpha_D \\ &= \frac{d_I}{f} + \frac{\ell_D/3}{f} \\ &= \frac{d_I + \ell_D/3}{f}\end{aligned}$$

where

- α_I = beam angle produced by the source iris diameter when the system is infinity-focused ($\ell_D = 0$)
- α_D = beam angle produced by the $f/3$ collection angle when the system is defocused
- d_I = iris diameter = 0.260 in. maximum
- ℓ_D = defocus distance
- f = focal length = 12 in.

Therefore, appropriately scaling the potentiometers which pick off d_I and ℓ_D and summing them produces a beam angle sensor (see Figure C-9). This analog summing avoids the necessity for input of both d_I and ℓ_D to the microprocessor, which would exceed the 8 channel capability of a single multiplexer in the microprocessor input interface.

c. Microprocessor Input Interface

Figure C-9 shows the microprocessor interface.

The code and caliber switches provide binary coded decimal (BCD) output in order to interface with the 8-bit data bus of the microprocessor.

The analog data from the various control potentiometers are converted to 8-bit binary data by the analog-to-digital (A/D) converter. Also undergoing A/D conversion are the analog data from: 1) the beam divergence sensor; and 2) the depression angle sensor. To utilize only a single A/D converter, switching of the analog inputs under microprocessor control is employed. The A/D converter is a single integrated circuit (IC) and the analog switch (multiplexer) is a single IC.

Three discrete signals are also sent to the microprocessor:

- Data enter command (initiates computation cycle);
- Fire command (initiates scan cycle); and
- End-of-bar-scan signal (provides necessary data to command scan cycle).

d. Microprocessor

The microprocessor is an Intel 8080 system. All elements shown in Figure C-10 are individual ICs.

The heart of the microprocessor is the central processing unit (CPU) which sequentially fetches program instructions from the permanent memory (the ROM - Read Only Memory) and performs those instructions. The CPU can perform a largelist of instructions and provides internal data storage registers to facilitate operations. External temporary storage is provided by the random access memory (RAM). The ROM and RAM are addressed by the CPU with a 16-bit address bus. Data flow from the ROM and to and from the RAM is on the 8-bit data bus. The CPU interfaces to the data bus with a system controller IC. A crystal driven clock generator provides the 0.5 μ s clock cycle for the CPU.

The data bus interfaces to data inputs and outputs through input/output (I/O) ports. The ports are addressed by the I/O decoder, the function of which is to decode the I/O port address on the address bus and provide a discrete on/off signal to the addressed port. The I/O ports store data until re-addressed. The system controller generates input and output commands on a single line running to all I/O ports. This additional address allows the same address on the address bus to address both an input port and an output port, thereby minimizing the number of I/O decoders needed.

The basic program sequence is shown in Figure C-11. Figure C-12 shows the program in the form that will be implemented. Only two simple software arithmetic routines are required -- multiplication and divide. Details of the program are discussed as follows:

AD-A034 453

INTERNATIONAL LASER SYSTEMS INC ORLANDO FLA
INDIRECT/AREA FIRE WEAPONS EFFECT SIMULATOR STUDY. VOLUME II. P--ETC(U)
JAN 77 R E ODOM

F/G 19/5

N61339-76-C-0070

UNCLASSIFIED

TND-TR-76-0002-VOL-2

NL

2 of 4
ADA034453



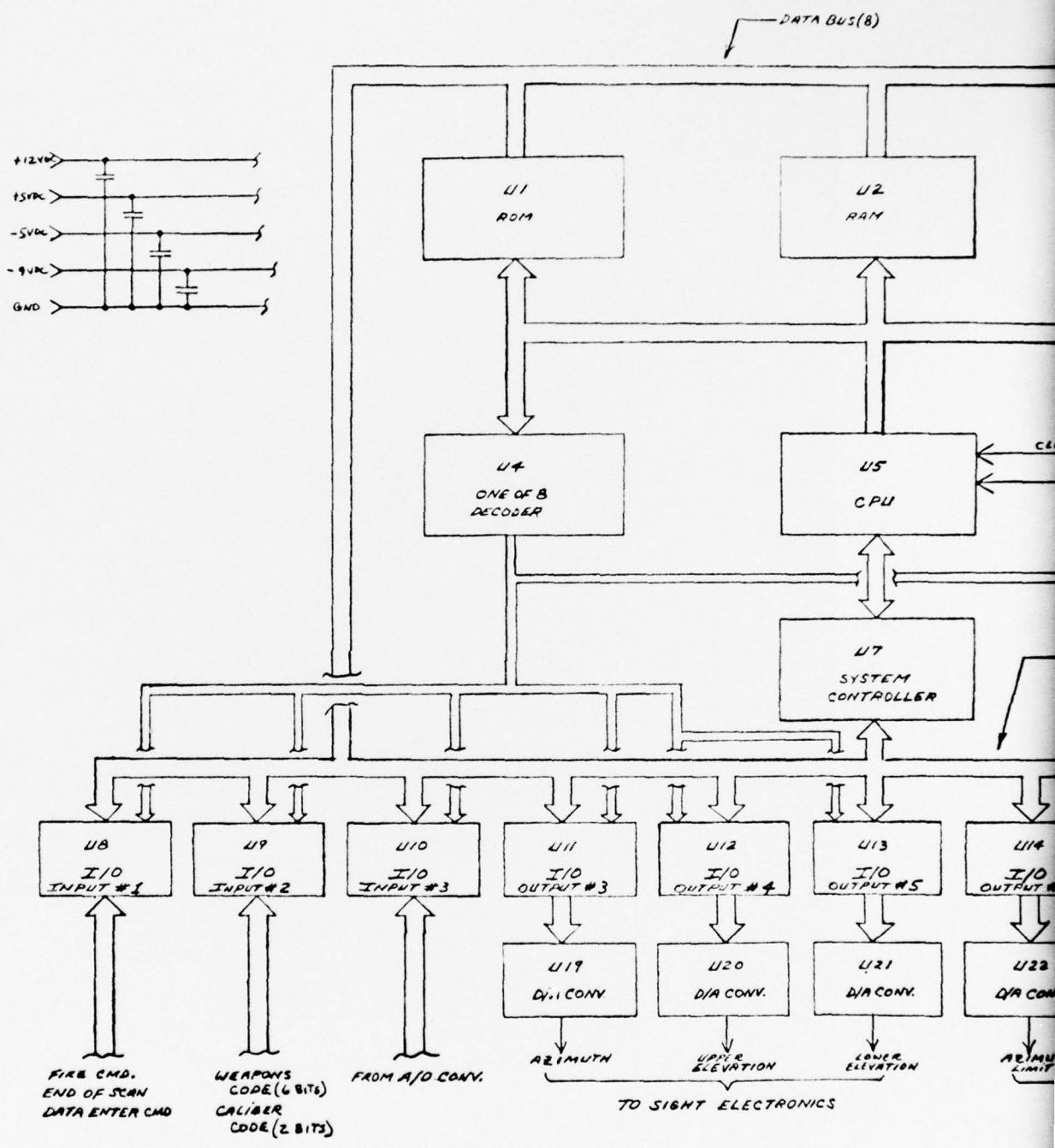
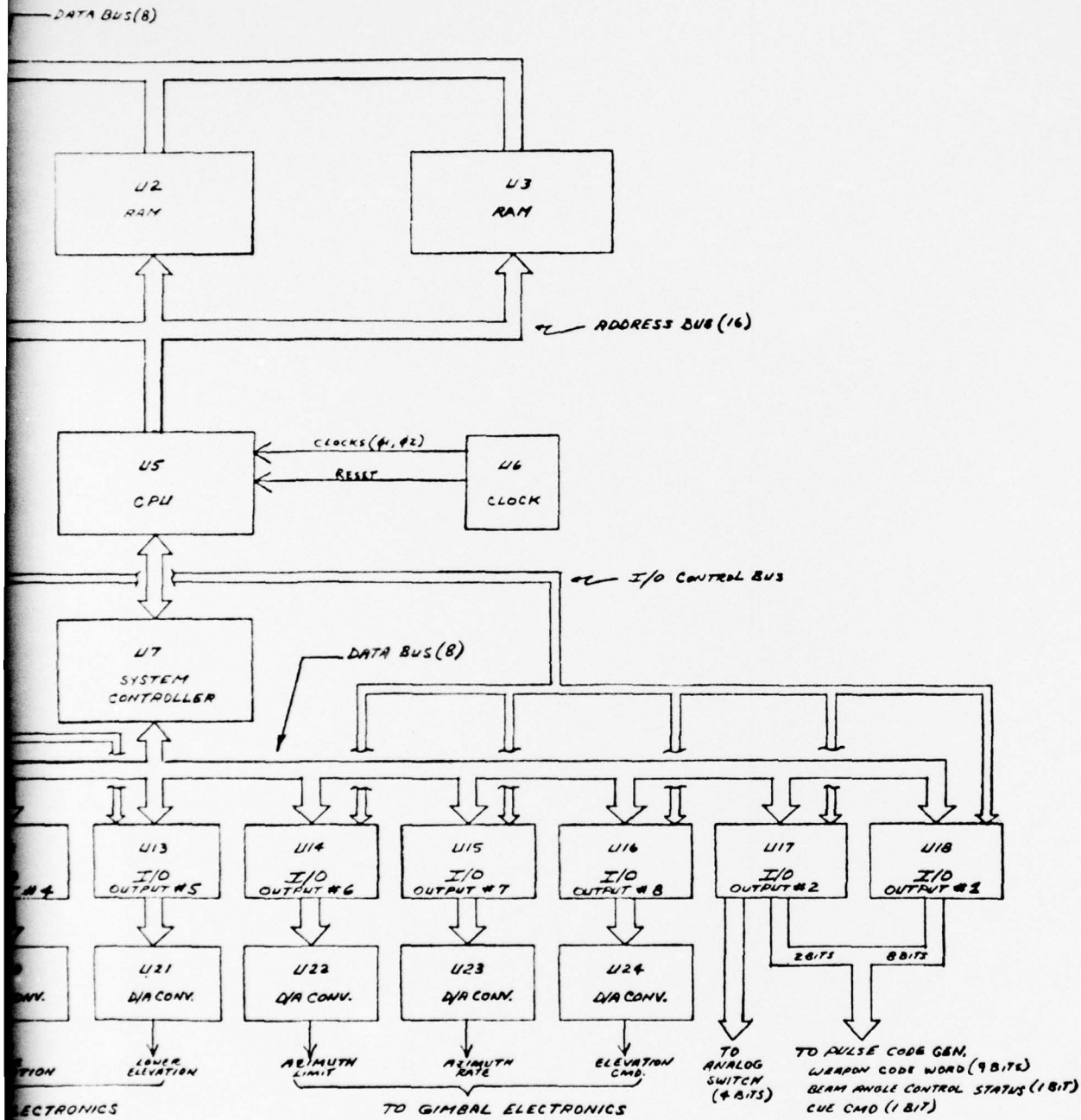
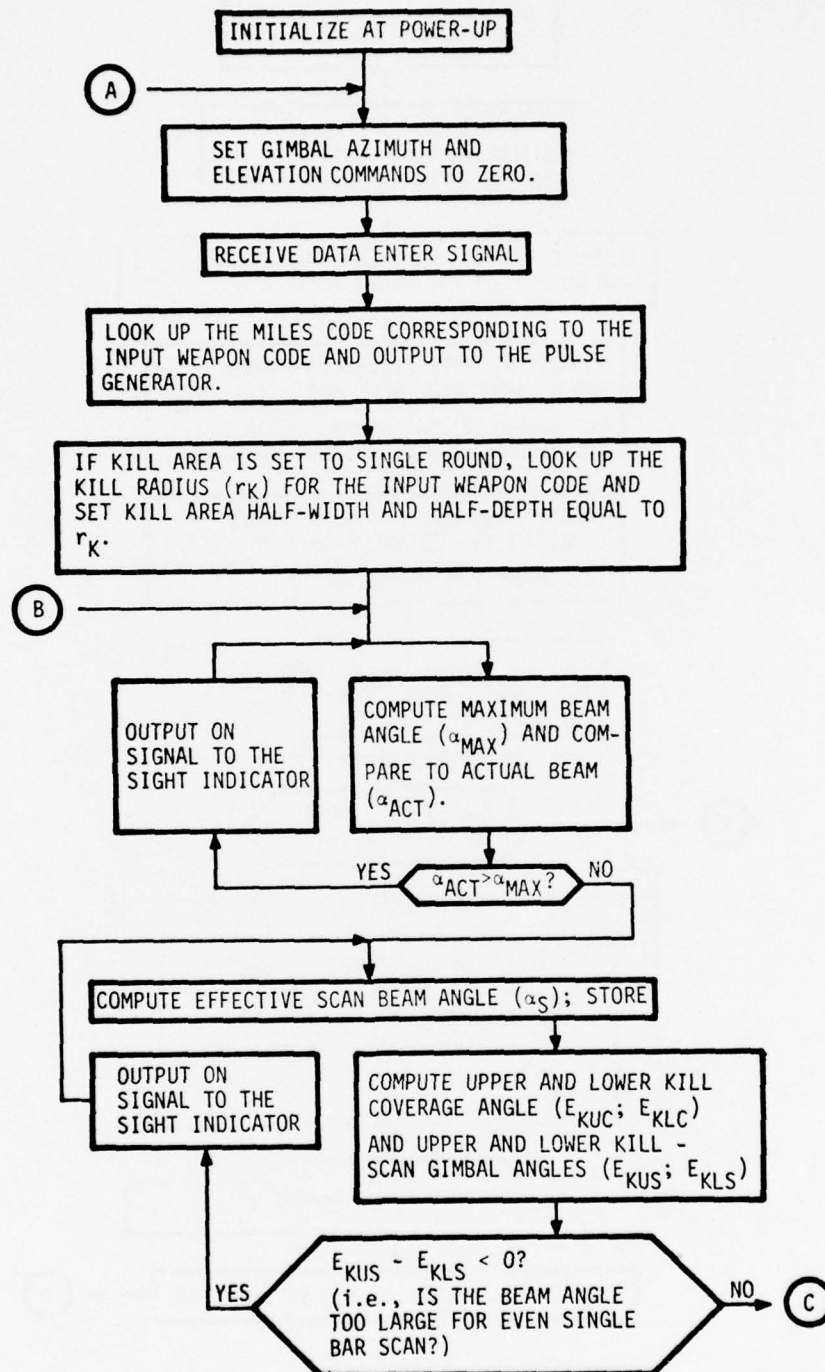

Figure C-10. Microprocessor and Input/Output Interface (Indirect/Area Fire Simulator System)



P3258

1 Input/Output Interface Electronic Block Diagram (Area Fire Simulator System)



P3196 -1

Figure C-11. Basic Program Flow

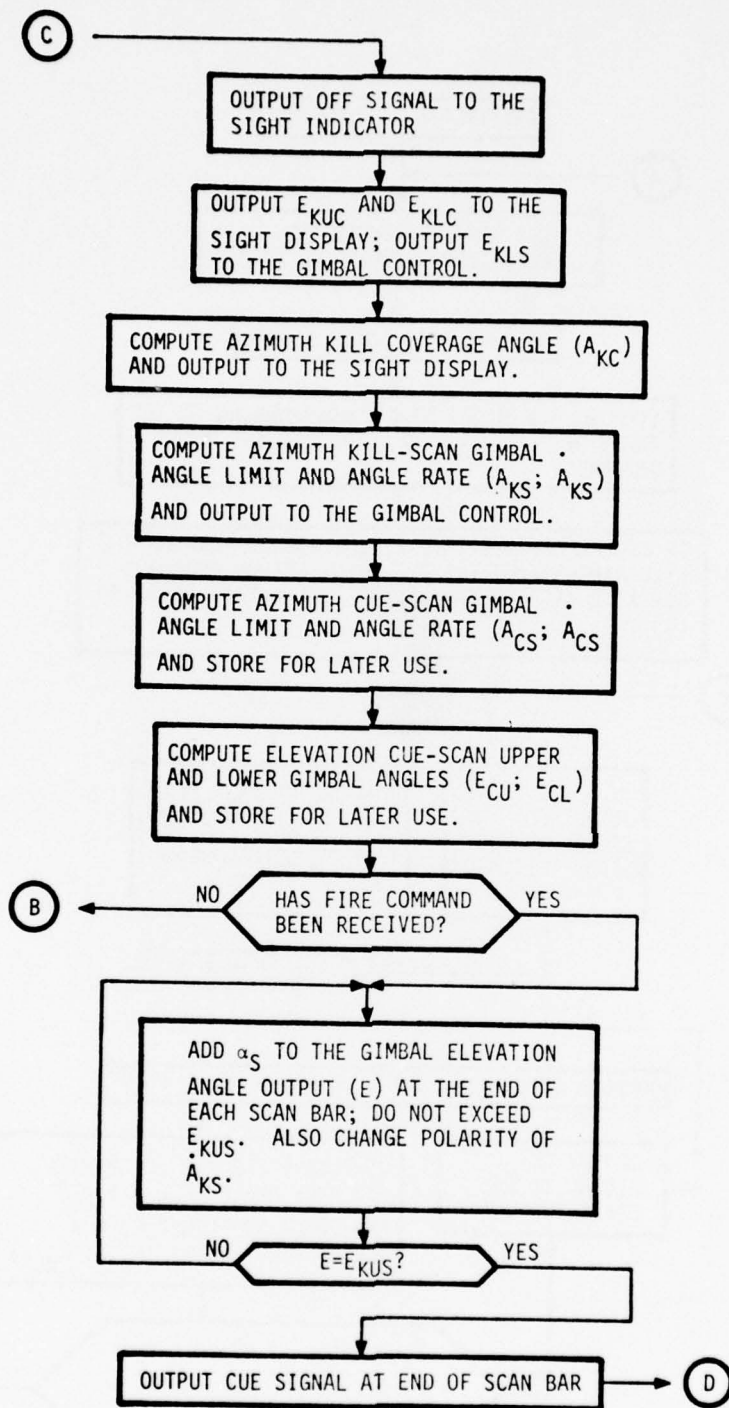

P3196-2

Figure C-11. Basic Program Flow (Cont'd)

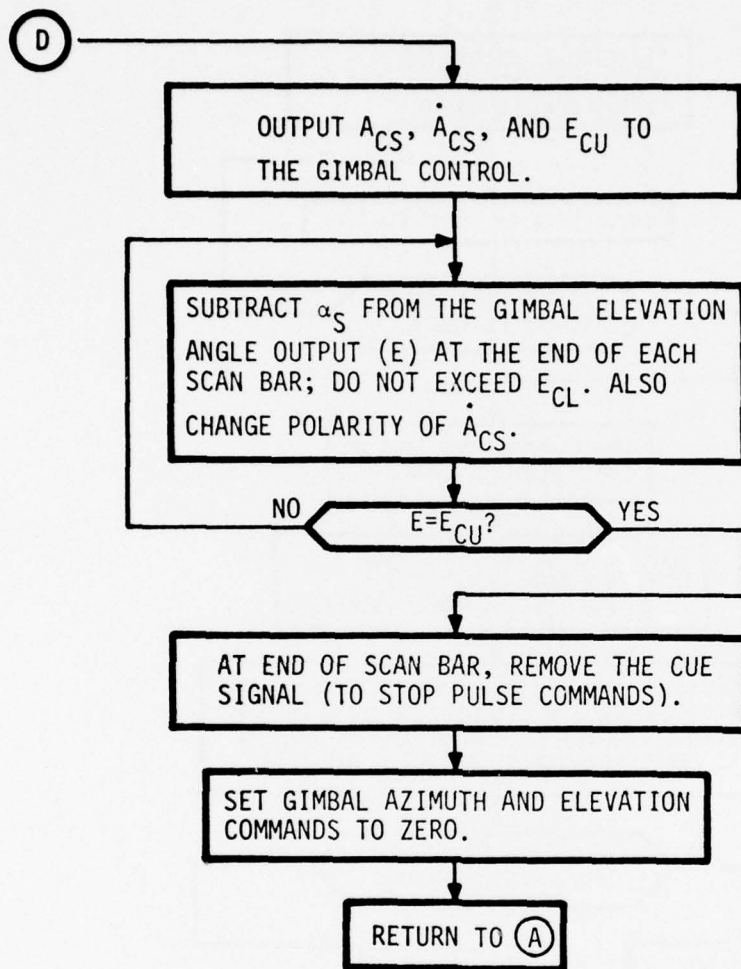

P3196-3

Figure C-11. Basic Program Flow (Cont'd)

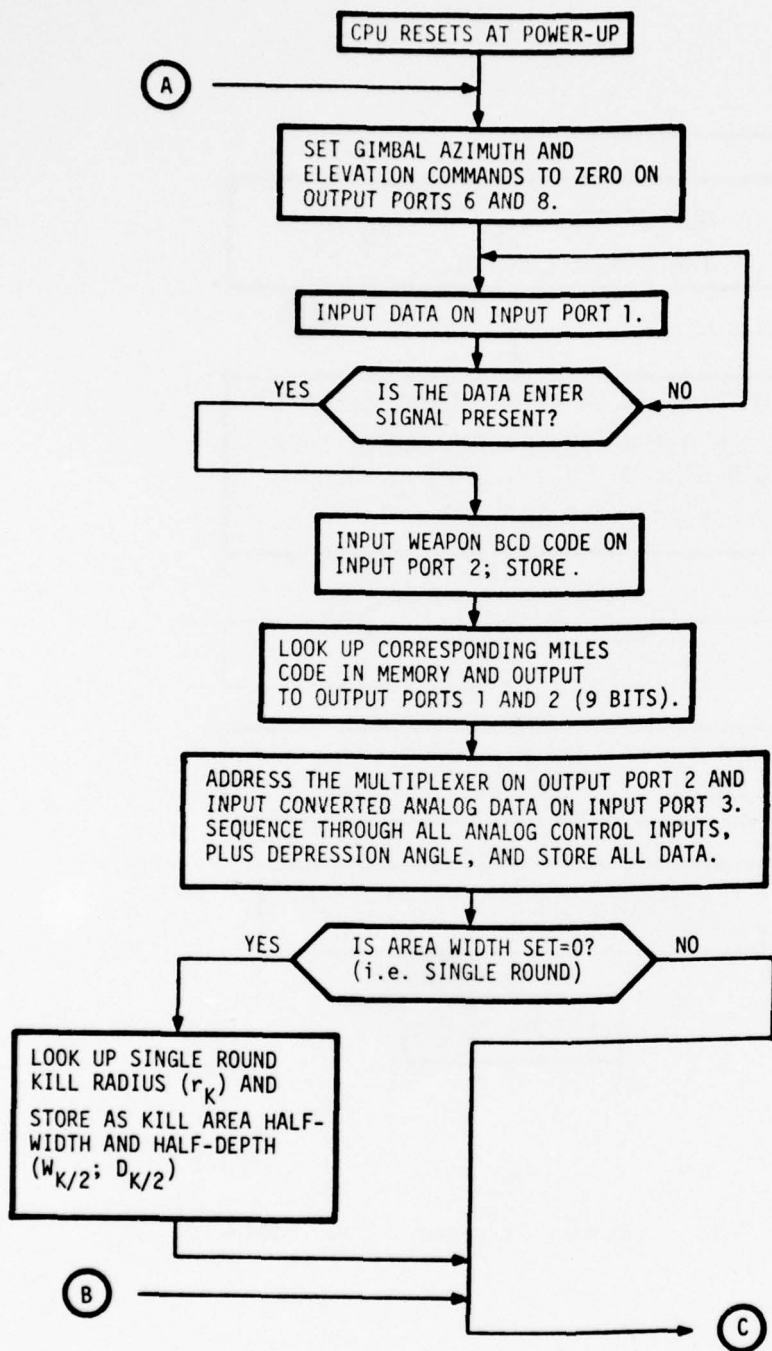

Figure C-12. Program Flow to be Implemented

P3197-1

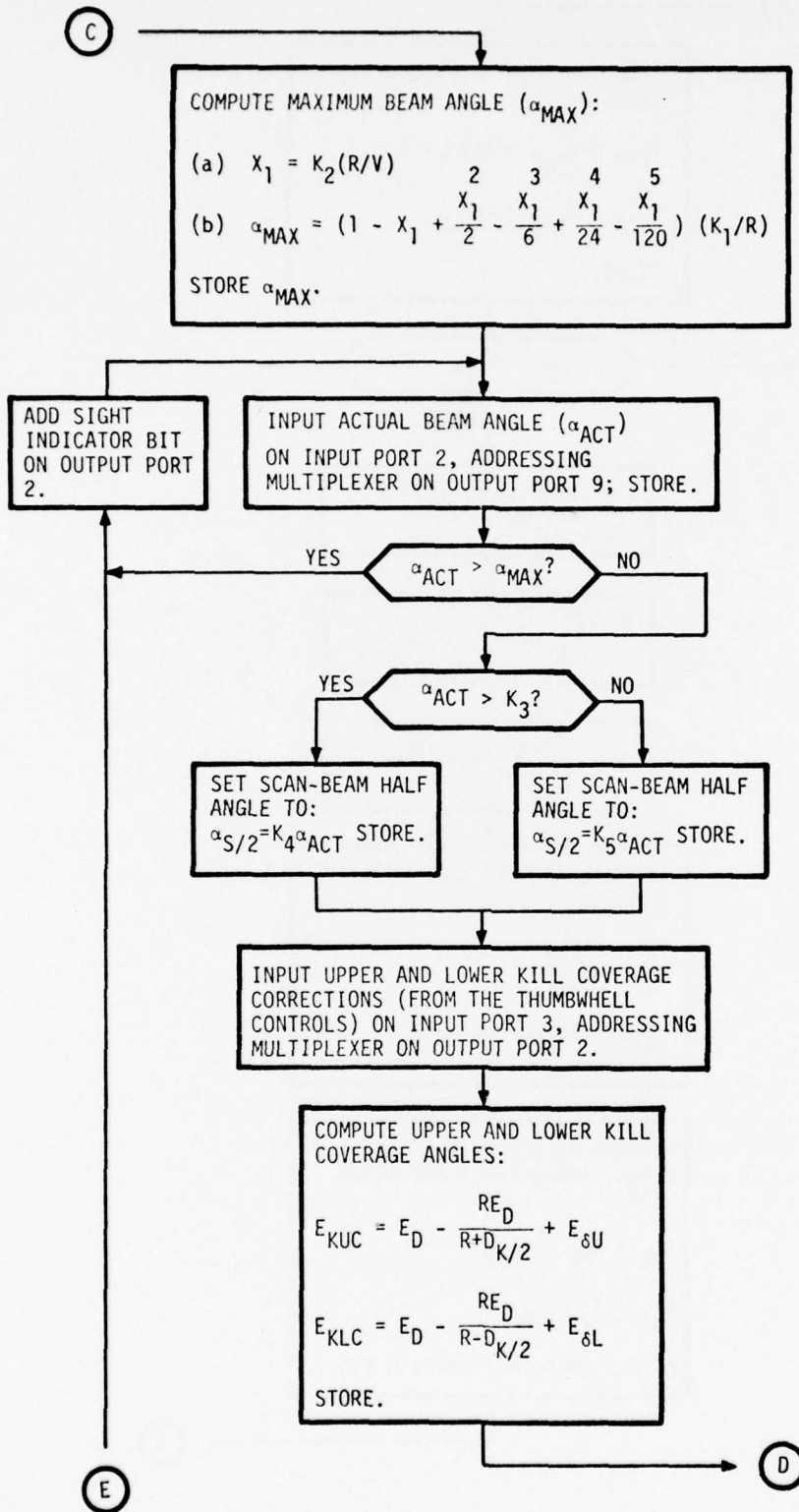
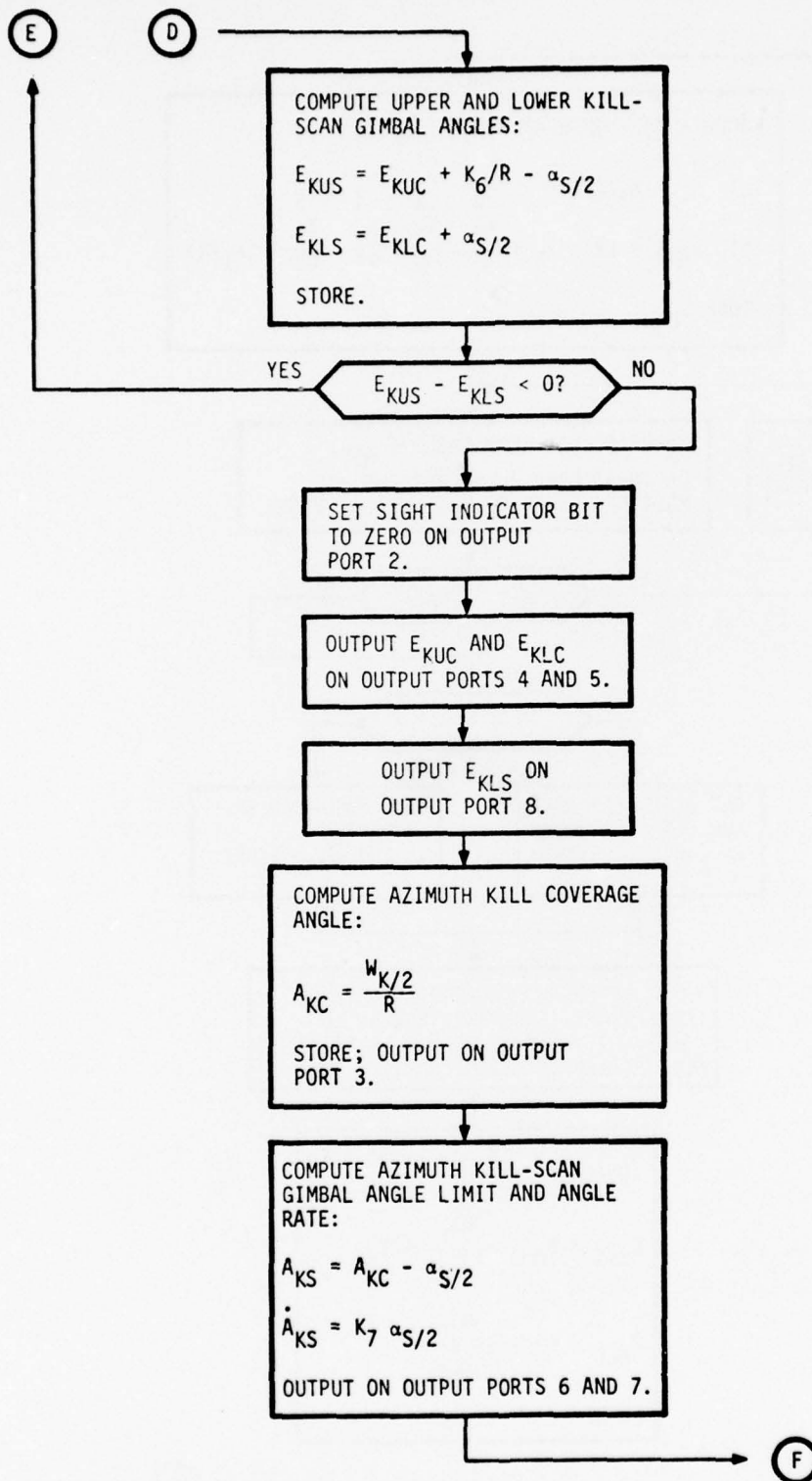

Figure C-12. Program Flow to be Implemented (Cont'd)

P3197-2



P3197-3

Figure C-12. Program Flow to be Implemented (Cont'd)

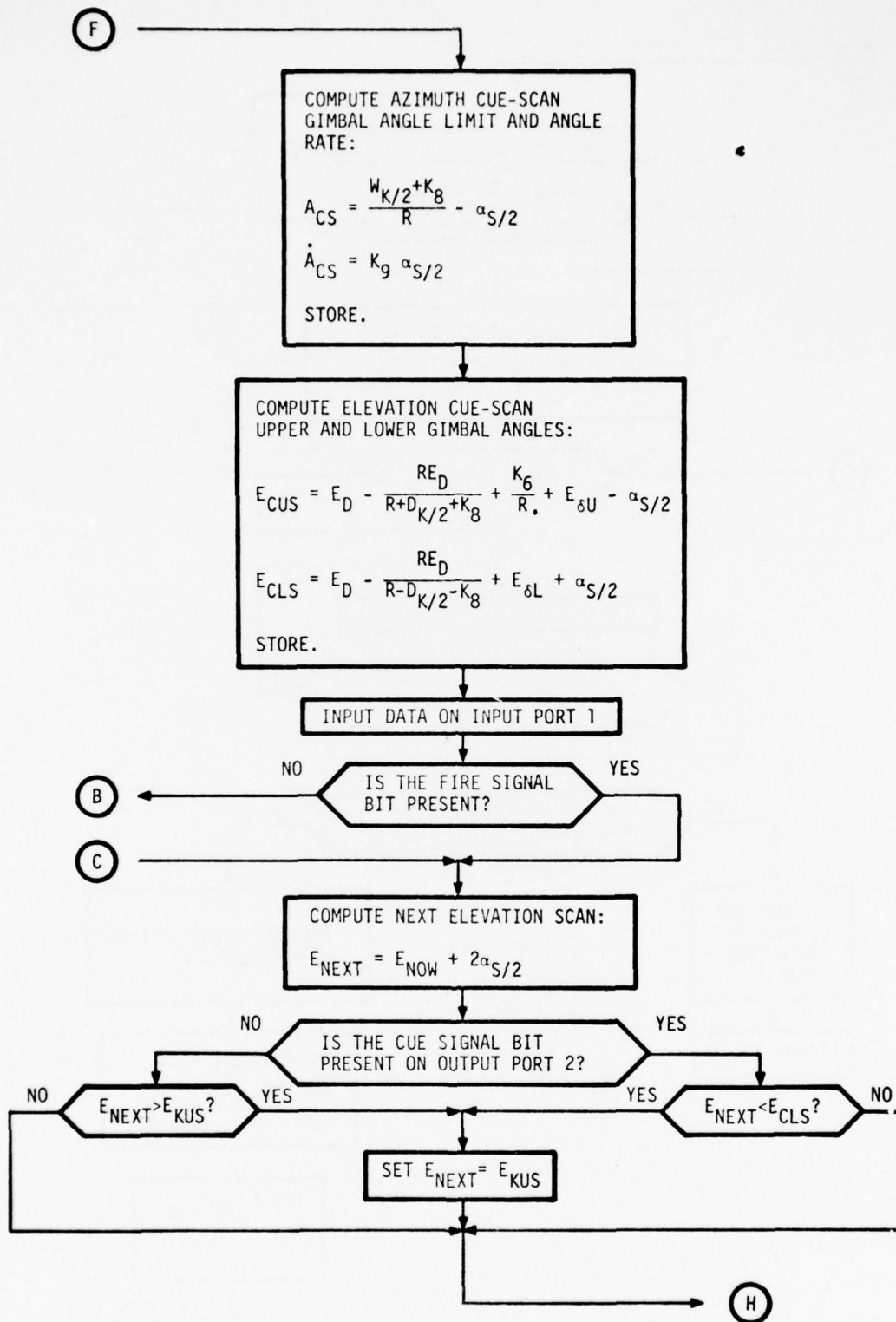

P3197-4

Figure C-12. Program Flow to be Implemented (Cont'd)

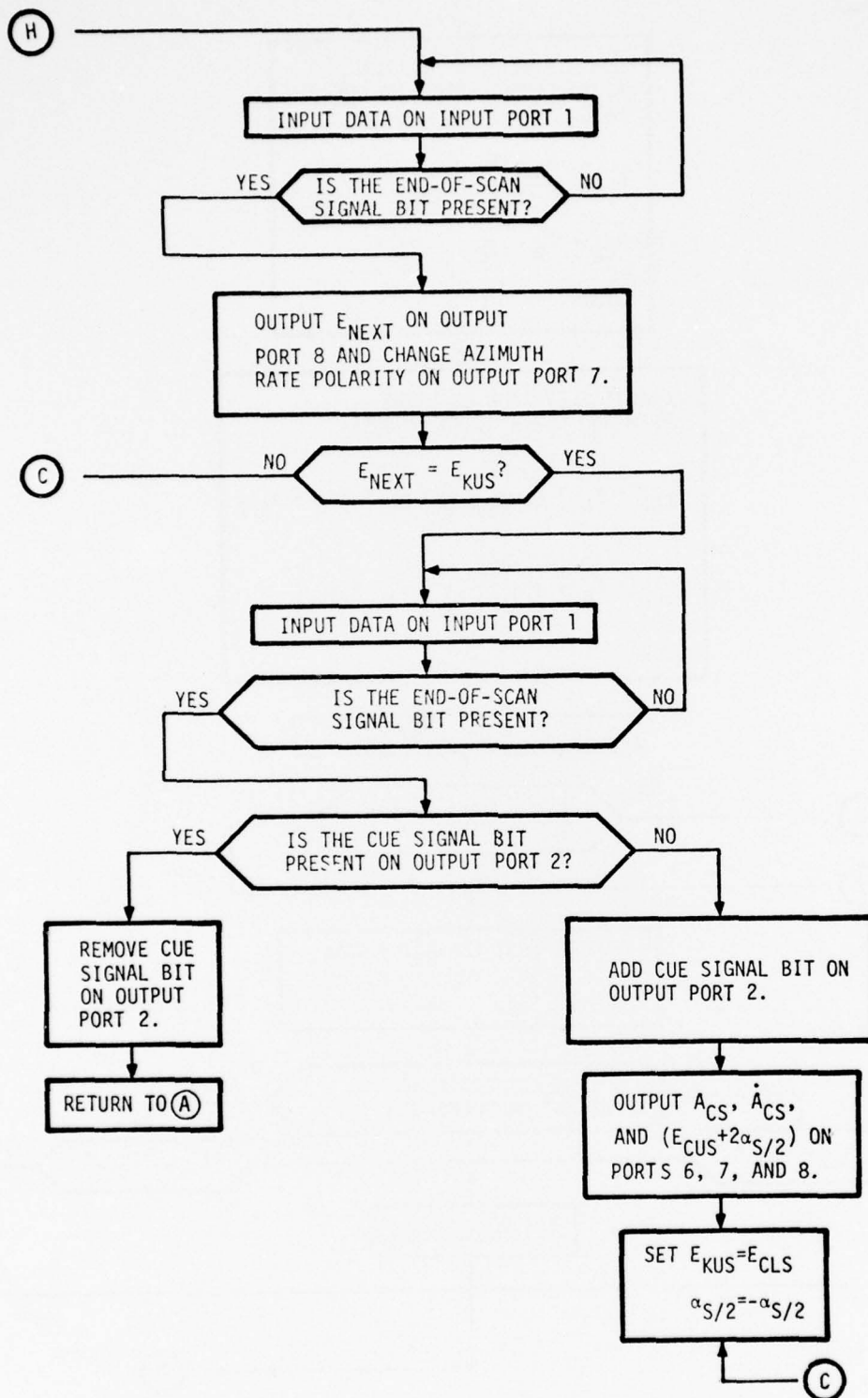

Figure C-12. Program Flow to be Implemented (Cont'd)

P3197-5

(1) Maximum Beam Angle Computation

From equation (1) of paragraph D.2. the maximum allowable beam angle (α_{\max}) is:

$$\alpha_{\max} = K_1 \sqrt{T_A}/R$$

where

$$\begin{aligned} K_1 &= \text{constant} \\ T_A &= e^{-k_1 R/V} \\ k_1 &= \text{constant} \end{aligned}$$

This can also be written as:

$$\alpha_{\max} = \left(K_1 e^{-K_2 R/V} \right) / R$$

where

$$K_2 = k_1/2$$

Using a series approximation for the exponential results in the implemented solution:

$$\alpha_{\max} = (K_1/R) \left(1 - X_1 + \frac{X_1^2}{2} - \frac{X_1^3}{6} + \frac{X_1^4}{24} - \frac{X_1^5}{120} \right)$$

where

$$X_1 = K_2 R/V$$

(2) Effective Scan Beam Computation

When the actual beam angle (α_{act}) is equal to or less than the maximum infinity-focused angle $K_3 = 0.260/12 = 0.022$ radian, the effective scan beam is the square inscribed in the beam circle; that is, scan beam azimuth and elevation angle (α_s) = $0.707 \alpha_{\text{act}}$, or half-angle ($\alpha_{s/2}$) = $K_4 \alpha_{\text{act}} = 0.3535 \alpha_{\text{act}}$.

When $\alpha_{\text{act}} > K_3$, the non-uniform beam power density requires a reduction in effective scan beam angle to $\alpha_{s/2} = 0.7 (0.3535 \alpha_{\text{act}}) = 0.247 \alpha_{\text{act}} = K_5$.

(3) Kill Elevation Angle Computations

The geometry of Figure C-13 clarifies elevation angle computations. The angles between aim point and the maximum and minimum depth of kill ($\pm D_{K/2}$) are:

$$E_{KUC} = E_D - \tan^{-1} \frac{h}{R + D_{K/2}} + E_{\delta U}$$

$$E_{KLC} = E_D - \tan^{-1} \frac{h}{R - D_{K/2}} + E_{\delta L}$$

where $E_{\delta U}$ and $E_{\delta L}$ are the corrections to the elevation kill coverage angles which the operator can set on the thumbwheel controls. Approximating the tangent by the angle for the small angles involved, and vice versa, produces the implemented kill coverage for sight display:

$$\left. \begin{aligned} E_{KUC} &= E_D - \frac{RE_D}{R + D_{K/2}} + E_{\delta U} \\ E_{KLC} &= E_D - \frac{RE_D}{R - D_{K/2}} + E_{\delta L} \end{aligned} \right\} \sim \text{radians}$$

The upper and lower scan angle limits allow for scan beam angle and also allow for the target height ($K_6 = 2$ meters):

$$E_{KUS} = E_{KUC} + K_6/R - \alpha_{s/2}$$

$$E_{KLS} = E_{KLC} + \alpha_{s/2}$$

(4) Kill Azimuth Angle and Angle Rate Computations

The azimuth kill angle coverage is simply

$$A_{KC} = \pm \tan^{-1} \frac{W_{K/2}}{R} \approx \pm \frac{W_{K/2}}{R} \sim \text{radians}$$

where $W_{K/2}$ = half-width of kill area.

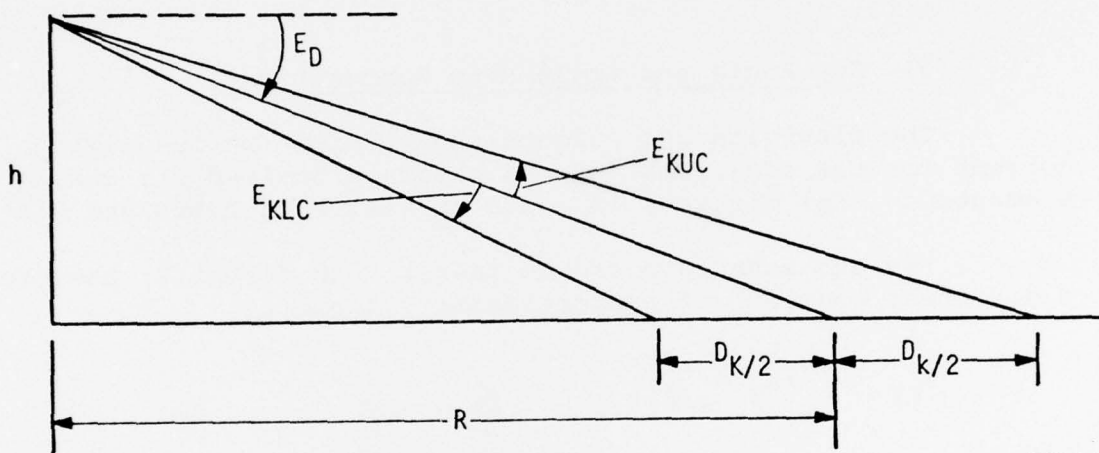

P3194

- h = operator height above target point
 $= R \tan E_D \approx R E_D$
- R = horizontal range to target point
- E_D = aiming depressing angle ~ radians
- $D_{K/2}$ = half-depth of kill area

Figure C-13. Elevation Kill Angle Geometry

The azimuth kill scan angle limit simply allows for beam angle:

$$A_{KS} = \pm(A_{KC} - \alpha_{s/2})$$

Maximum allowed scan rate is proportional to effective scan beam angle; therefore:

$$\dot{A}_{KS} = \pm K_7 \alpha_{s/2}$$

(5) Cue Angle and Angle Rate Computations

The elevation and azimuth scan limits for cue simply correct for the additional ground coverage desired for cueing. A constant ($\pm K_8$) distance is added to kill half-depth and width.

The cue scan rate can be faster than for kill; therefore, a different constant of proportionality appears:

$$\dot{A}_{CS} = \pm K_9 \alpha_{s/2}$$

(6) Wait-for-Fire-Command Mode

The program keeps recycling until the fire command is given, providing the feedback for beam angle adjustment via the beam defocus and iris controls and the indicator lamp in the sight.

(7) Scan Mode Operations

Gimbal control initiates scanning when the fire command is given. At the end of each scan bar the microprocessor program steps the elevation gimbal command by an incremental angle equal to the effective scan beam angle ($\alpha_s = 2 \alpha_{s/2}$). The program calculates the next elevation step while the gimbal scans the present elevation command. The gimbal control generates the end-of-scan-bar signal which tells the microprocessor to output the new elevation step.

The scan pattern is indicated in Figure C-14. Gimbal control responds to the gimbal angles generated before fire command (A_{KS} , E_{KLS}) to position the gimbal for initiation of kill scan at the lower left corner. After fire command the gimbal control responds to the azimuth rate command, sweeping the gimbal to the right and maintaining the commanded elevation angle. When the right hand azimuth limit ($+A_{KS}$) is reached, the microprocessor senses end-of-scan-bar and reverses the polarity of the azimuth rate command and steps the elevation command. In this manner the kill scan is performed as shown. The last kill-scan elevation command cannot exceed the value (E_{KUS}) that defines the required kill area.

After generating and outputting E_{KUS} the microprocessor waits for the end of this last kill scan bar. When the end-of-bar signal is sensed the microprocessor generates the cue signal to the code generator which changes the laser pulse code to the cue pulse rate. The microprocessor then outputs the cue scan azimuth limit, azimuth rate and upper scan limit (plus α_S). The gimbal control responds by slewing the gimbal to the new elevation command and increasing the azimuth scan rate. When the azimuth limit is reached the gimbal control generates the end-of-bar signal, the microprocessor reverses azimuth rate polarity and steps the elevation down by α_S , and the gimbal begins scanning the defined cue area. In this manner the cue scan is performed as shown. The last elevation command cannot be less than the value (E_{CLS}) that defines the required cue area. At the end of that scan bar the microprocessor removes the cue command to stop further pulsing, generates gimbal zeroing commands, and waits for another data enter indication (that is, another mission).

The 0.5 μ s clock cycle of the microprocessor should ensure that all program functions will be performed fast relative to operator adjustments before fire command and gimbal response after fire command.

An accuracy study has not been performed to ensure that the 256 increment resolution of 8-bit data is adequate for all computations, although it appears to be. However, even if greater accuracy were required for some inputs, outputs, or computations, the inputs and outputs simply require some additional I/O ports and the program is easily modified; the CPU already provides double precision (16-bit) operations.

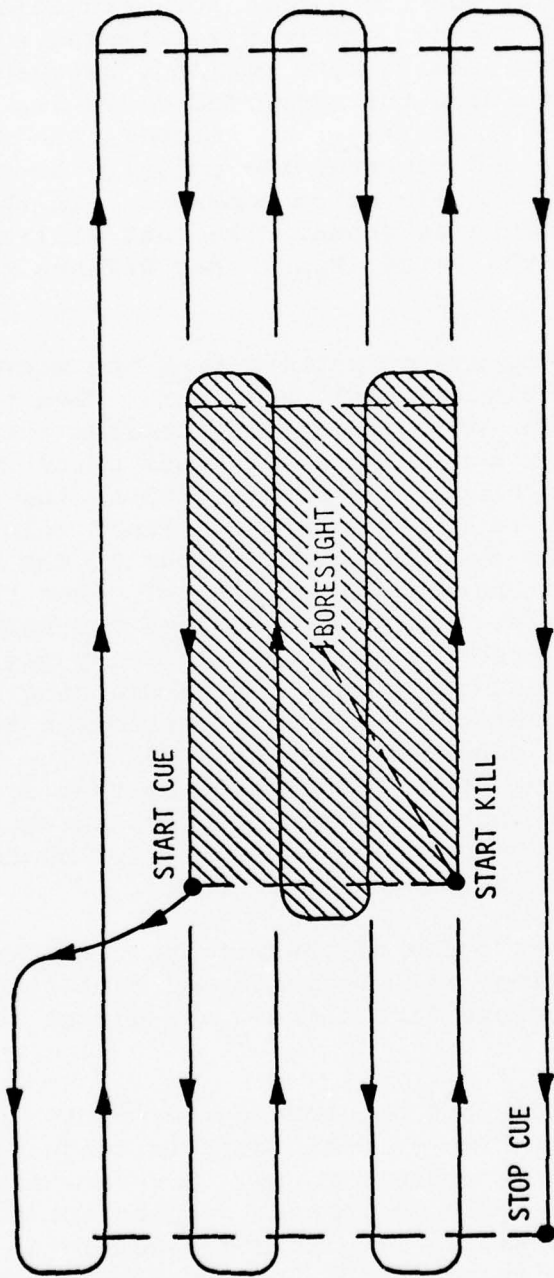

P2989

Figure C-14. Scan Pattern

e. Microprocessor Output Interface

The microprocessor output interface consists of the 6 digital-to-analog converters providing the analog commands to the gimbal and the sight display.

f. Gimbal Control

The gimbal control block diagram is shown in Figure C-15. Azimuth and elevation position control loops are provided, as well as logic to sense the end of a scan bar and generate the end-of-bar scan signal.

Initially the position commands are zero (boresight) because the azimuth rate integrator output is held at ground level and the elevation command is switched to ground level (an offset can be generated by boresight adjustment potentiometers). Upon receipt of the Data Enter Command, latch 1 is set, which commands the azimuth loop to the negative azimuth limit and the elevation loop to the initial elevation command (see Figure C-14). The Fire Command sets latch 2, which allows the azimuth rate integrator to begin generating the azimuth sweep command. When the azimuth limit is reached, the threshold comparator generates the end-of-bar scan pulse, which causes the microprocessor to reverse azimuth rate polarity and step the elevation command. The azimuth gimbal then sweeps back to the opposite azimuth limit. Scan continues in this manner until the Cue Command is removed at completion of scan. At that time latches 1 and 2 are reset which returns the gimbal to boresight.

A simple position control loop is adequate for elevation using potentiometer pickoff of gimbal angle for feedback and cascade lead compensation to achieve stability and good time response to elevation step commands. However, shaping of input command is necessary to avoid torquer saturation for the larger angle-position commands. Best performance in azimuth is achieved by creating an inner rate damping loop employing tachometer pickoff of azimuth angular velocity. The azimuth position control loop is closed around this inner loop and is similar to the elevation position loop.

Time response in elevation for the smaller step commands is 0.02 sec. Longer time is required for the larger step commands because the command shaping limits the angular rate to a value consistent with linear operation; however, the longer bar

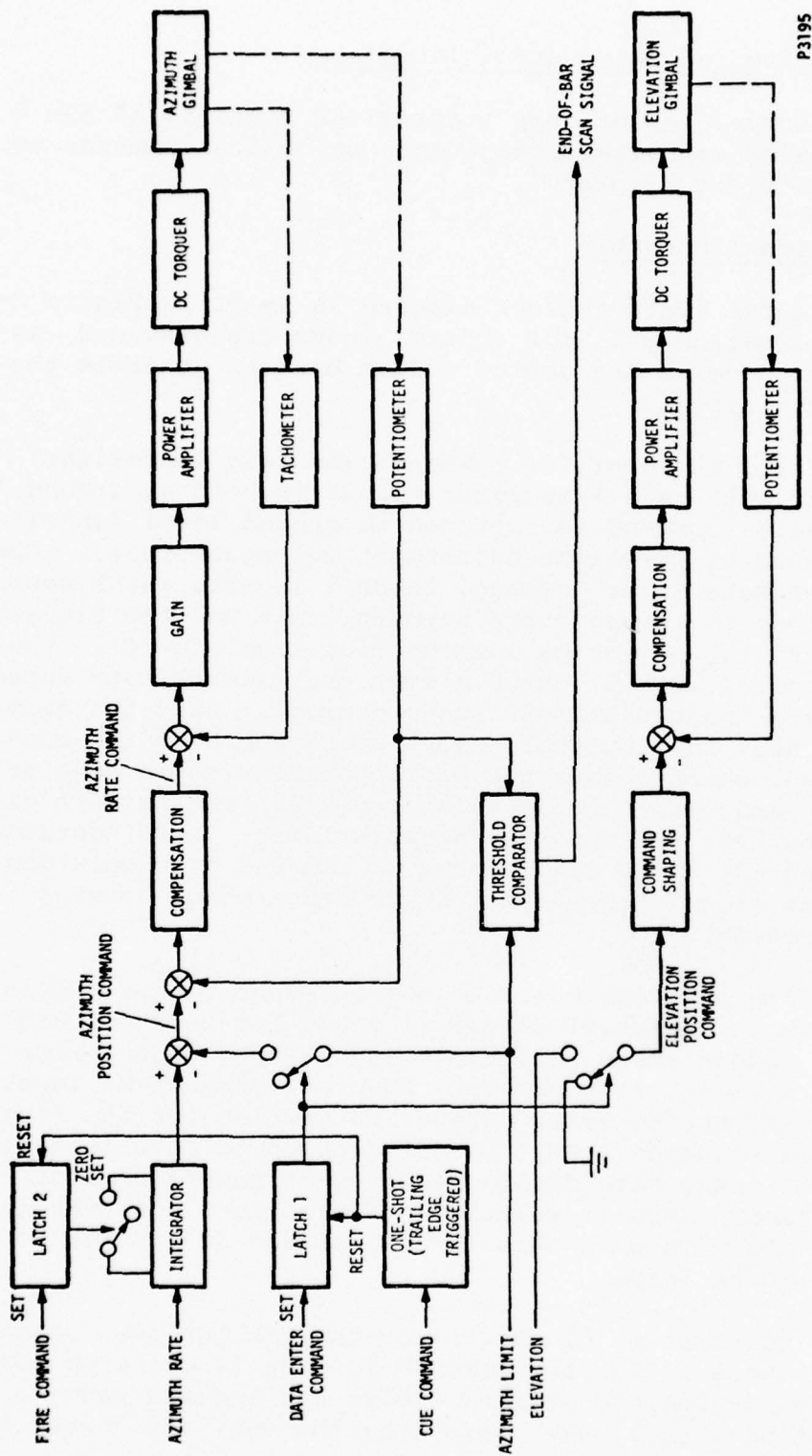

Figure C-15. Gimbal Control Block Diagram

scan time associated with these larger steps permits the longer time response. The azimuth loop settles onto the ramp command generated by the azimuth rate integrator in 0.10 sec. The loop is designed for a maximum scan rate of 6 rad/sec, and the microprocessor is designed to limit the rate command to that value. As shown in paragraph E, these performance parameters permit less than two seconds total scan time for most situations.

This performance represents a reasonable tradeoff between scan time and system weight. The latter is impacted chiefly by the torquer size, which not only adds weight directly to the system but also indirectly:

- The elevation torquer weight adds to the gimbal inertia with which the azimuth torquer must contend; and
- Larger torquers tend to require more power and, therefore, add to battery weight.

The electronic implementation of the gimbal electronics is shown in Figure C-16. The design includes dynamic braking (shorting) of the torquers to provide power-off loose "caging", which protects the gimballed mirror (together with soft gimbal limit stops).

g. Pulse Code Generator

The pulse code generator (PCG) of Figure C-17 generates the weapon kill and cue codes. The kill code is the MILES format of 16 bits at 0.512 ms bit spacing (with only three bits active in the first 9-bits of any one code and the last 7 bits always set to zero). The microprocessor commands the kill code to be generated. At receipt of the fire command the PCG loads the code into the 16-bit shift register. The kill clock starts shifting the bits out of the register at the 0.512 ms clock rate when the fire command is given. Feeding the register output back into the input keeps the code word circulating. Each bit clocked out of the register is a pulse command to the laser driver.

Upon receipt of the cue command from the microprocessor the circulation path of the register is interrupted, kill code pulse commands are inhibited, and the cue clock pulses are allowed to start generating pulse commands. (Note that the register empties during cue pulsing.) The cue code is simply a constant PRF of 0.496 ms -- that is, $31 \times 16 \mu\text{s}$ as opposed to the MILES

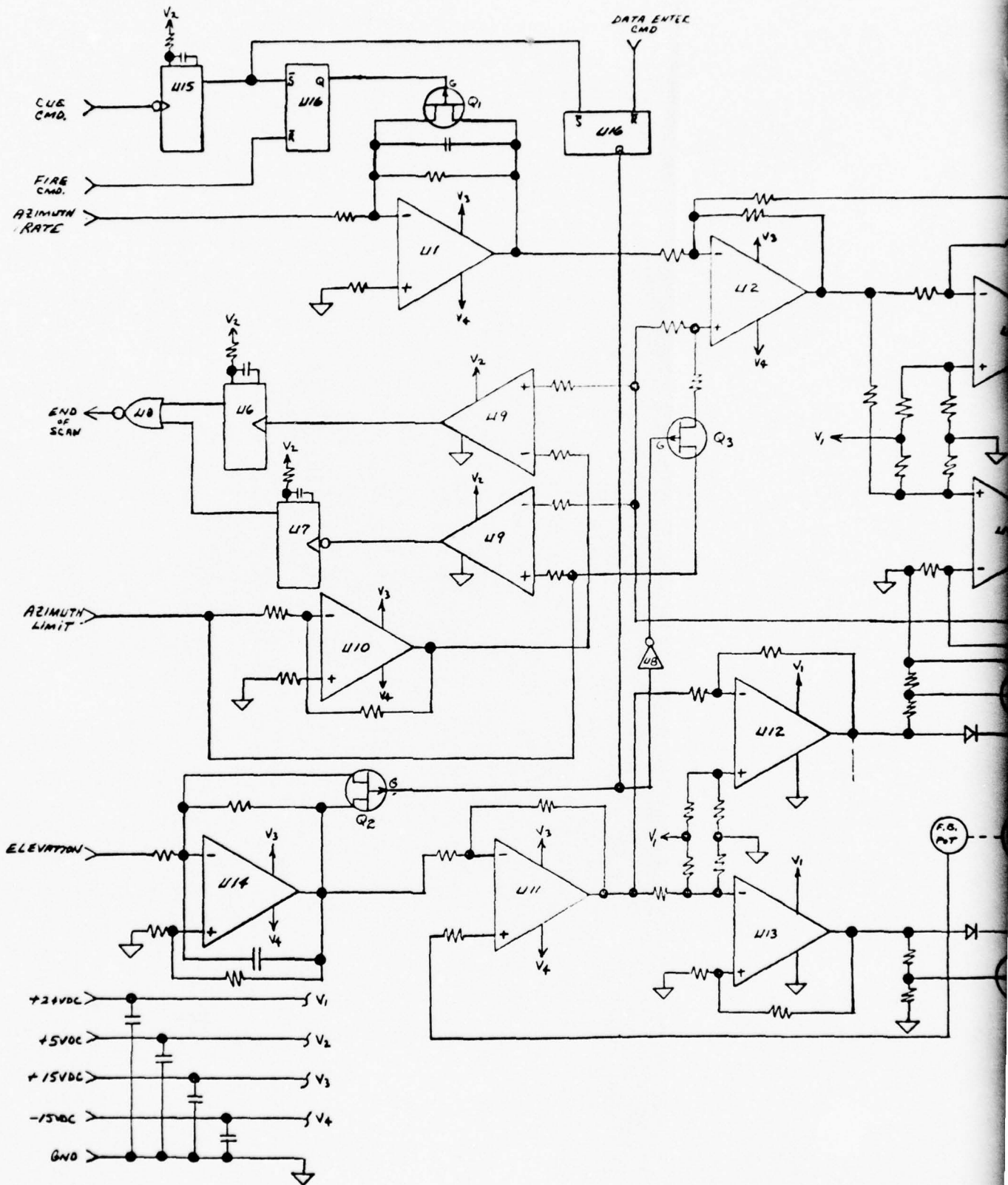
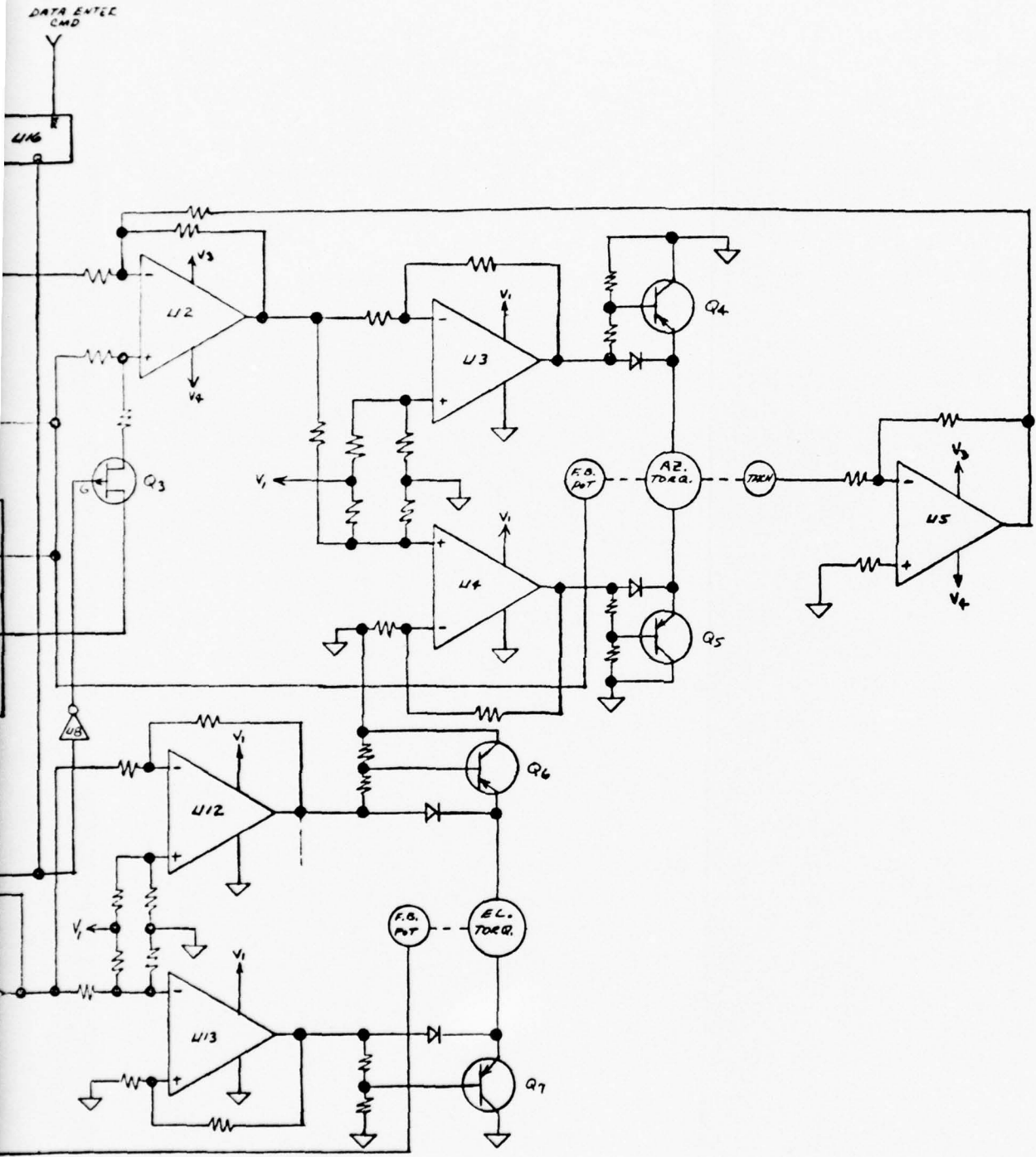

Figure C-16. Elevation and Azimuth Gimbal



P3259

16. Elevation and Azimuth Gimbal Control

2

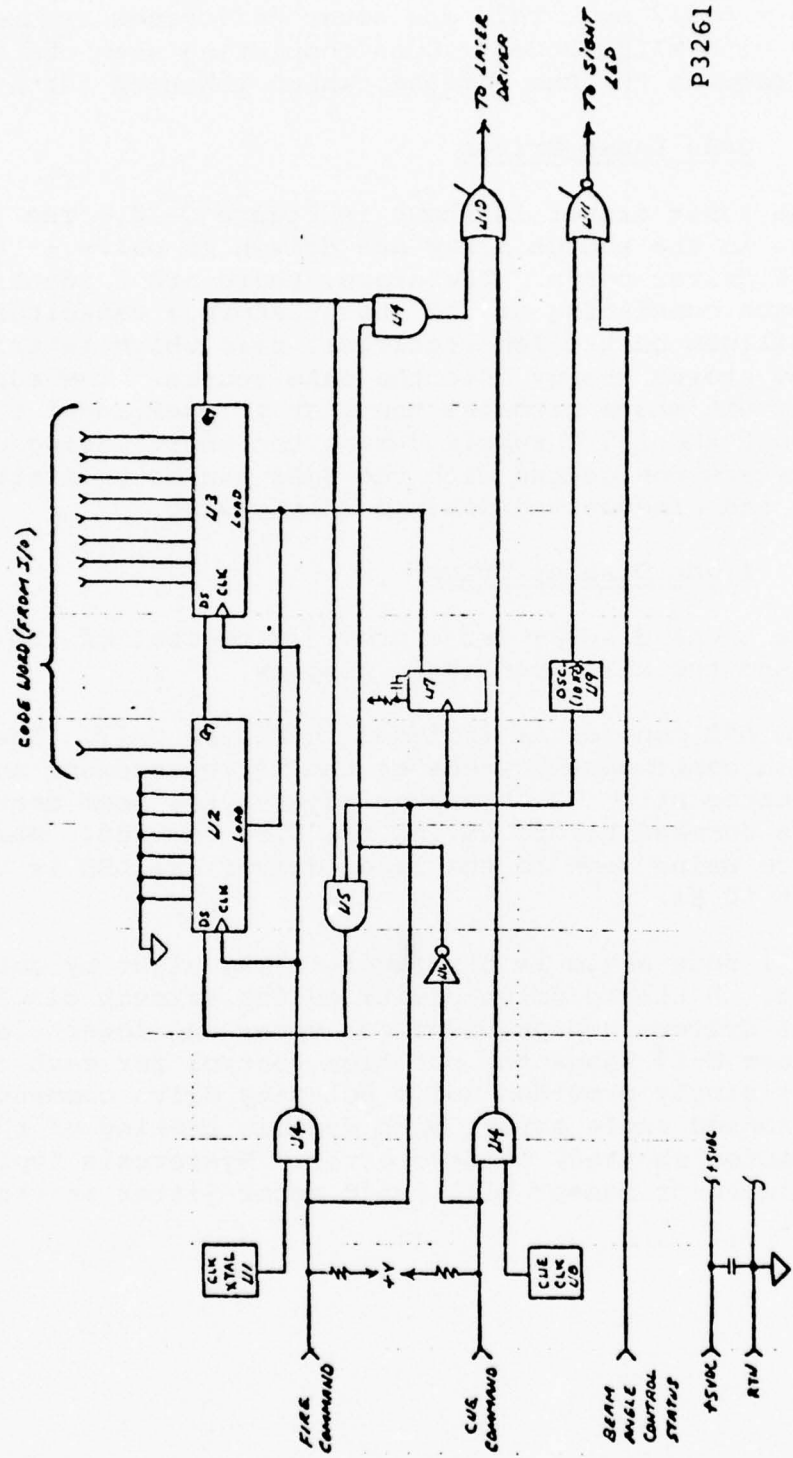

P3261

Figure C-17. Pulse Code Generator
(Indirect/Area Fire Simulator System)

$32 \times 16 \mu\text{s} = 0.512 \text{ ms}$. This one count difference assures no interference with MILES codes. Upon completing scan the microprocessor removes the cue command, which inhibits further pulsing.

h. GaAs Laser Driver

The laser driver is shown in Figure C-18. The 10 rows of GaAs diodes in the source array are driven in pairs -- that is, there are 5 driver ports. Therefore, there are 5 identical drivers, each consisting of the energy storage capacitor C_1 and the SCR (silicon controlled rectifier) pair which is triggered to dump the stored energy into the GaAs source. The additional control circuit shown produces the fast trigger input to the SCRs and shuts off the 175 V supply during the short lasing period. The drivers are co-located with the GaAs source to minimize lead inductance and produce the desired short pulse.

i. Sight Display Drive

The sight display drive provides control of the sight LED indicator and the kill scan angle display.

The LED control is included in Figure C-17. The LED is commanded on continuously whenever the microprocessor outputs the sight indicator bit. The operator adjusts the beam controls to remove this command before giving the Fire command. When pulse commands are being sent to the laser driver the LED is commanded to flash at 10 Hz.

Kill scan angle is displayed in the sight by motor-driven cross hairs. A single drive positions the azimuth display, but independent drivers are provided for upper and lower elevation scan. Figure C-19 shows the position control for each channel. The circuit simply provides motor polarity drive commands in response to sensed angle error, with dynamic braking of the motor (that is, motor shorted) at zero error. Hysteresis implementation of the angle error sensor will avoid motor jitter in the near-zero error zone.

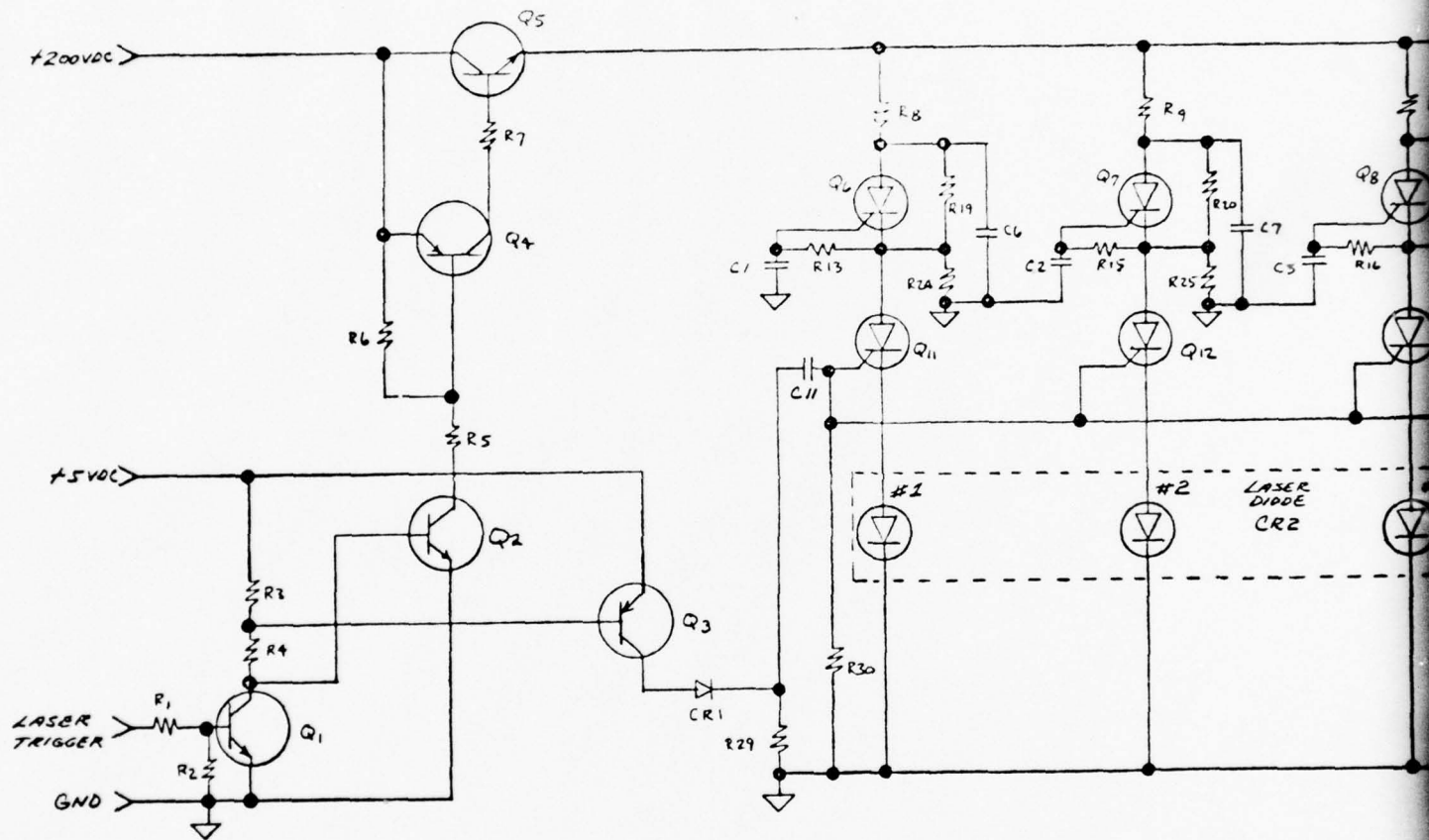
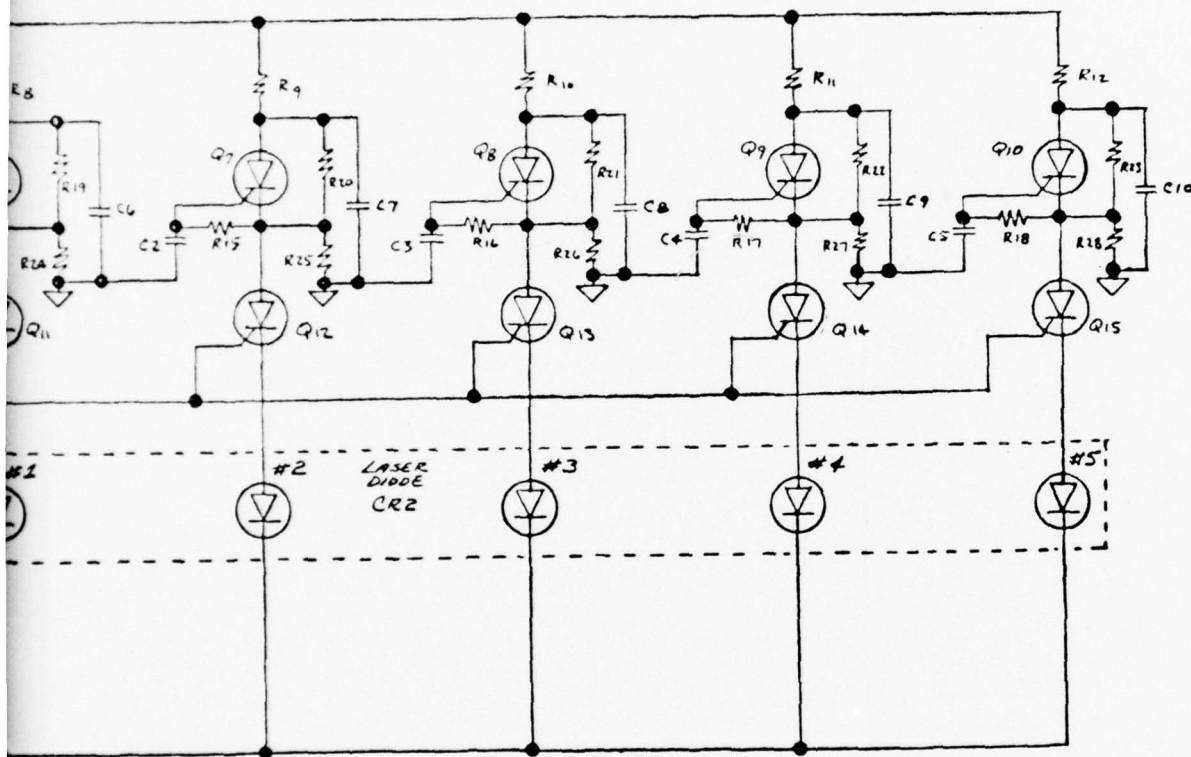

Figure C-18. Laser Driver Electronics
(Indirect/Area Fire Simulator System)



P3256

3. Laser Driver Electronics
(Area Fire Simulator System)

C-59/60

Handwritten signature

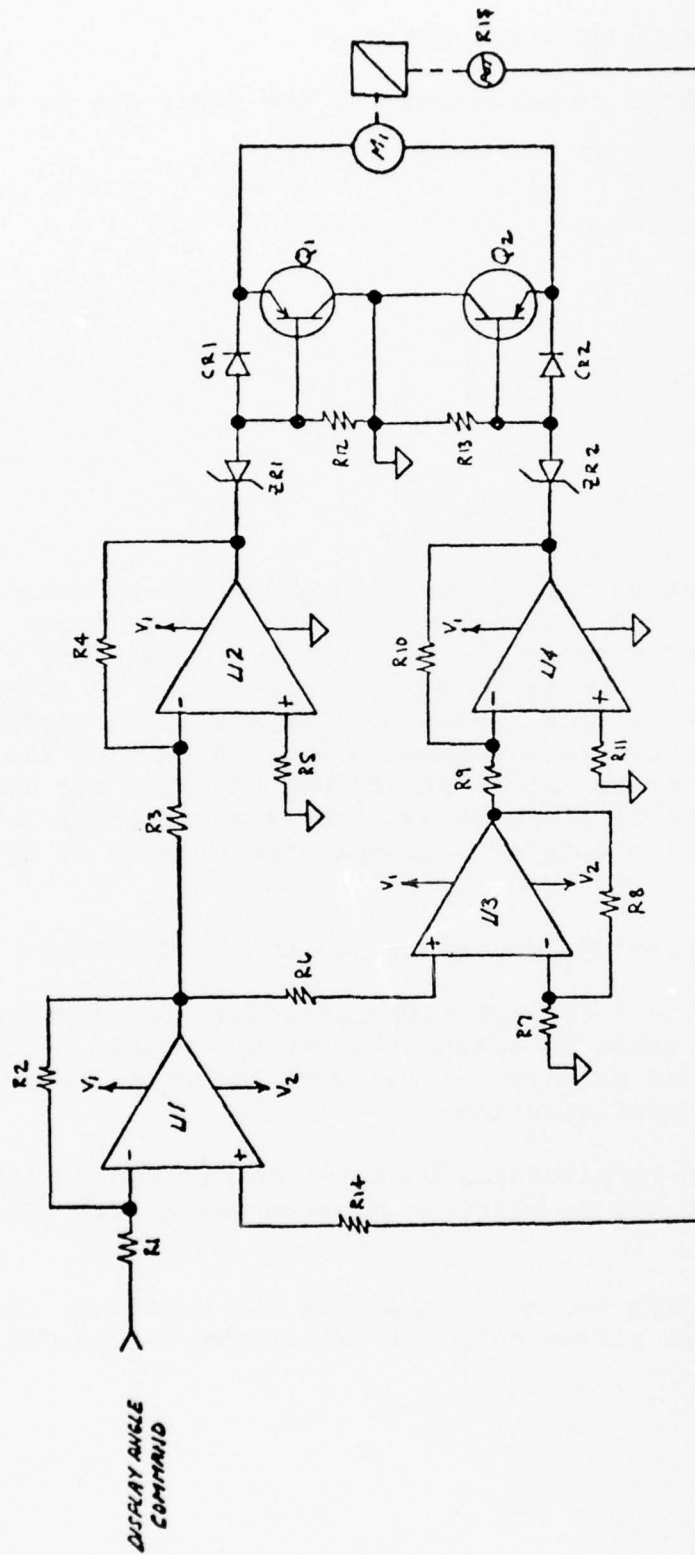

Figure C-19. Sight Display Control (1 of 3 Circuits)
 (Indirect/Area Fire Simulator System)

j. Power Supply and Battery

The voltage requirements for the laser are as follows:

- Regulated
 - +5 V
 - 5 V
 - 9 V
 - +12 V
 - +15 V
 - 15 V
- Unregulated
 - +15 V
 - +24 V
 - +200 V

The power supply (regulators and DC-to-DC converters) is shown in Figure C-20. Input current and voltage requirements for each voltage source are given in Table C-4. The duty time (per simulation) associated with each voltage supply is also shown. A realistic 20 sec control set-up time plus scan is allowed for the operations described in paragraph D.4.a. Actuation time of the 3 sight display drive motors should not exceed 1 sec each. An average scan time of 2 sec is assumed (see paragraph E.3.), during which the elevation torquer only operates briefly at the end of each scan bar.

The battery design reduces to two candidates:

- Integrate the battery pack with the laser configuration to avoid a power cable to a separate battery pack. Choose high energy per pound primary (throw-away) batteries to add minimum weight to the configuration; or
- Use a separate rechargeable battery pack to reduce the battery operating cost and to maintain minimum weight for the laser itself.

The first candidate has been chosen as the baseline, but the configuration design allows optional use of the second design candidate.

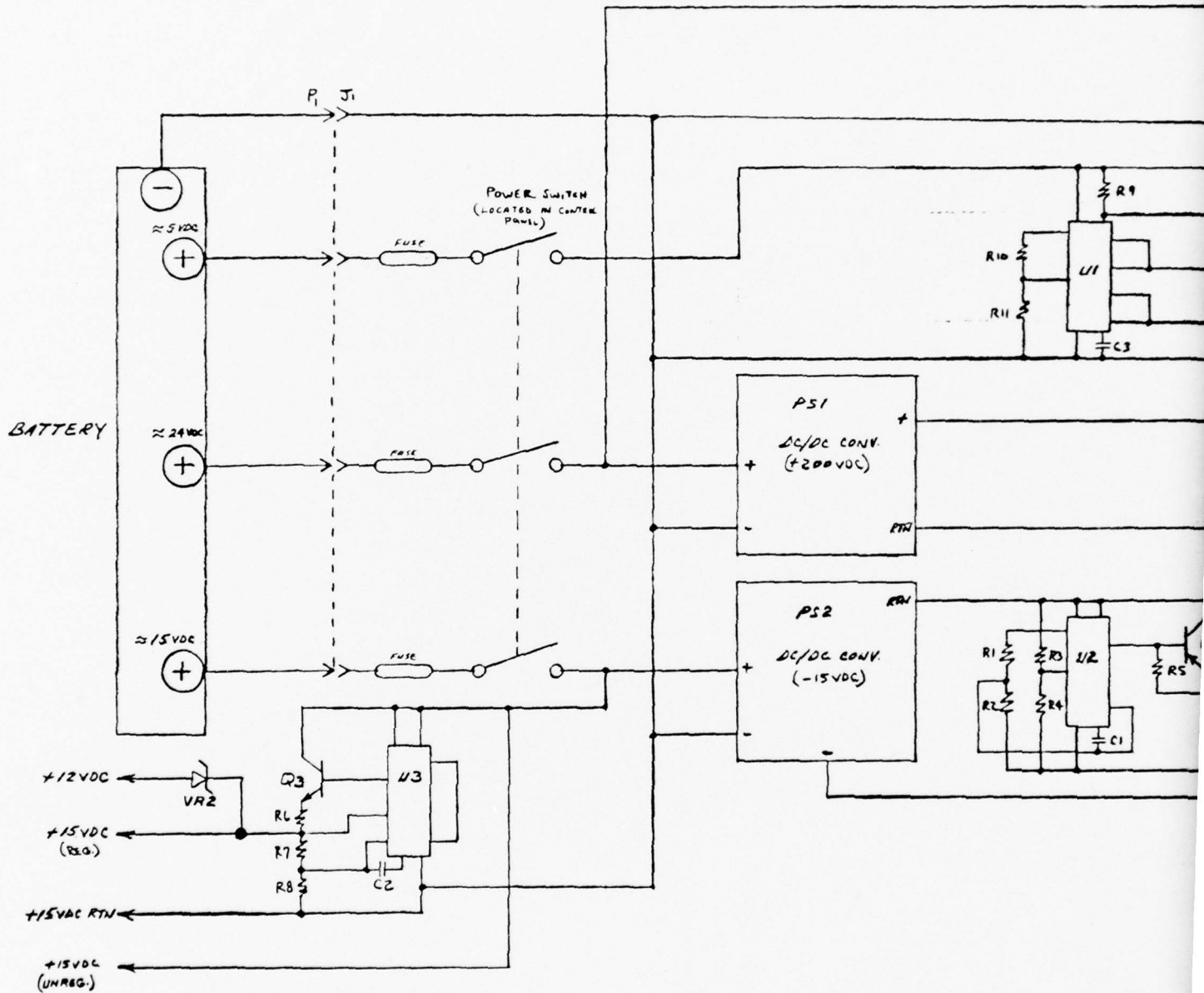
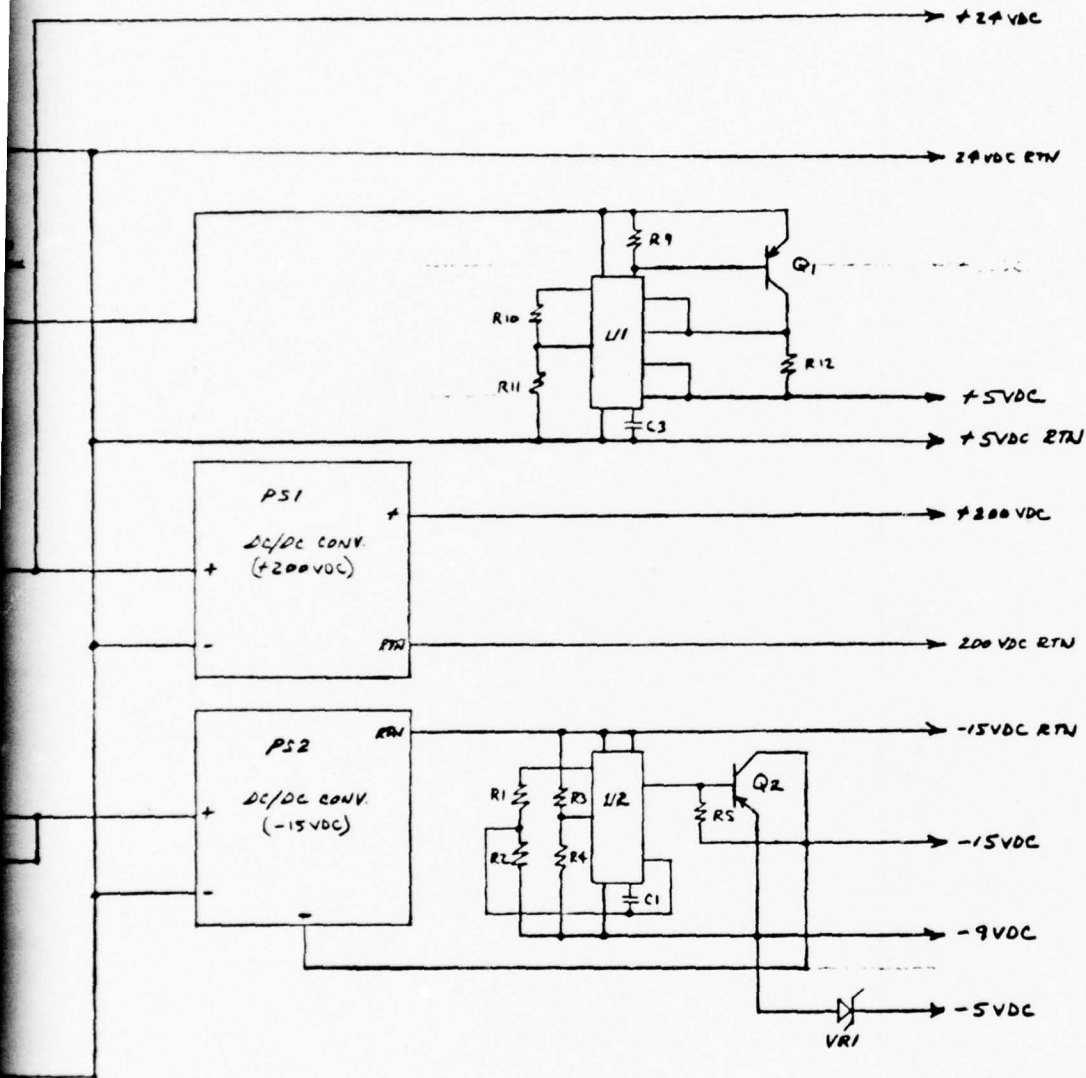

Figure C-20. Power Supply
(Indirect/Area Fire Simulator System)



P3260

Figure C-20. Power Supply
(rect/Area Fire Simulator System)

2

Table C-4. Power Supply Input Requirements

| Supply | Input Current | Source Voltage | Supply Utilization | Duty Time (per simulation) |
|--|------------------------|----------------|--------------------------------------|----------------------------|
| +5 V Regulator | 1.750 A | ~ 5 V | Electronics | 20 sec |
| +12 V } +15 V } Regulator | 0.190 A | ~ 15 V | Electronics | 20 sec |
| -5 V } -9 V } -15 V } Converter/ Regulators | 0.165 A | ~ 24 V | Electronics | 20 sec |
| +15 V Unregulated | 0.250 A | ~ 15 V | Sight display motors | 3 sec |
| +24 V Unregulated | { 0.710 A 1.100 A } | ~ 24 V | Azimuth torquer Elevation torquer | 2 sec Brief |
| +200 V Converter | 0.670 | ~ 24 V | GaAs drive | 2 sec |

(1) Lithium Primary Battery Pack

The lithium primary battery is the definite choice for the baseline design because it provides the greatest energy per pound and cubic inch than any other battery, requires fewer cells because of its high cell voltage, and has other excellent characteristics (including temperature, shelf life, and discharge curve, see Table C-5). In addition, the cost per W-hr is not much greater than other primary batteries.

Table C-4 shows that the optimum battery would have taps of 5.5, 15, and 25 V. The nominal voltage of a single lithium cell is 2.8 to 2.9 V which indicates that a 9 cell tapped battery pack could provide 5.6, 16.8 and 25.2 V. However, Table C-4 also indicates that the current out of the first cells providing the 5.6 V supply current and all other higher voltage supply currents is:

- Long term (20 sec) = $1.750 + 0.190 + 0.165 = 2.0$ A
- Short term (2 sec) = $2.0 + 0.710 + 0.670 = 3.4$ A
- Intermittent = $3.4 + 1.1 = 4.5$ A

The 4.75 A peak current reduces cell working voltage to 2.1 V in a standard "D" cell. Therefore, the first tap must be provided by 3 cells, producing 6.3 V (maximum load) to 8.4 V (open circuit). The life of the "D" cell for the average 2.1 A drain is over 1.0 hr at -20°F to $+125^{\circ}\text{F}$. The supply current requirements for the remaining batteries are:

- Long term (20 sec) = $2.0 - 1.75 = 0.25$ A
- Short term (2 sec) = $3.4 - 1.75 = 1.65$ A
- Intermittent = $4.5 - 1.75 = 2.75$ A

The 2.75 A peak current reduces working voltage to 2.0 V in a standard "C" cell. Therefore, the second tap must be provided by 5 more cells, producing 16.3 V (maximum load) to 22.4 V (open circuit), and the last tap must be provided by another 4 cells, producing 24.3 V (maximum load) to 33.6 V (open circuit). That is, a 12 cell battery pack is required. The life of the "C" cell for average 0.38 A drain is more than 5 hr at -20°F to $+125^{\circ}\text{F}$.

The resulting weight of the 3 "D" cells (3.0 oz each) and the 8 "C" cells (1.7 oz each) is 22.6 oz, or 1.4 lb.

Table C-5. Electrical Characteristics of Primary Batteries

| | Leclanche | Zinc-Chloride | Alkaline | Magnesium | Mercury-Oxide | Silver-Oxide | Divalent Silver-Oxide | Lithium |
|---|---------------------------------------|---|---------------------------------------|---|--|-----------------------------|-----------------------------|------------------------------|
| 1. Energy output Watt-hours per lb. Watt hours per in. ³ | 20 2 | 44 3 | 20 to 35 2 to 3.5 | 40 4 | 46 6 | 50 8 | 70 14 | 100 to 150 8 to 15 |
| 2. Nominal cell voltage | 1.5 | 1.5 | 1.5 | 2.0 | 1.35 or 1.4 | 1.50 | 1.5 | 2.8 |
| 3. Practical drain rates Pulse High (>50 mA) Low (<50 mA) | Yes 100 mA/in. ² Yes | Yes 150 mA/in. ² Yes | Yes 200 mA/in. ² Yes | No 200 to 300 mA/in. ² Yes | Yes No Yes | Yes No Yes | Yes No Yes | Yes Yes Yes |
| 4. Impedance Z _i | Low | Low | Very low | Low (Delay on start up) | Low | Low | Low | Less than 1 Ω |
| 5. Temperature range Storage Operating | -40 to 120°F 20 to 130°F | -40 to 160°F 0 to 160°F | -40 to 120°F -20 to 130°F | -40 to 160°F 0 to 160°F | -40 to 140°F 32 to 130°F | -40 to 140°F 32 to 130°F | -40 to 140°F 32 to 130°F | -65 to 160°F -40 to 130°F |
| 6. Temperature vs capacity | Poor at low temperature | Good at low temperature compared to Leclanche | Fair to good at low temperature | Fair at low temperature | Good at high temperature poor at low temperature | Poor at low temperature | Poor at low temperature | Excellent |
| 7. Shelf life at 68°F to 80% initial capacity (in years) | 2 to 3 | 2 to 3 | 3 to 5 | 2 to 3 | 2 to 3 | 2 to 3 | 2 to 3 | 3 to 5 (estimated) |
| 8. Shape of discharge curve | sloping | sloping | sloping | fairly flat | flat | flat | flat | flat |

Battery cost is \$4.95 per "D" cell and \$4.15 per "C" cell in quantities of 1,000, yielding a total battery pack replacement cost of \$52.20. However, note that the "C" cell replacement rate need only be 1/5 of the "D" cell rate, producing a possible average pack replacement cost of \$22.32.

The battery pack life of over 1 hr (as limited by the "D" cell drain) for temperatures of -20°F to +125°F satisfies the 200 simulation requirement.

(2) Gelled-Electrolyte Lead-Acid Rechargeable Battery Pack

The "gel cell" is the choice for the optional battery pack design because it is the lowest cost (200 to 500 cycles at lower cost than the single cycle lithium battery), eliminates the troublesome "memory" characteristics of NiCd cells, produces the highest cell voltage, results in reasonable weight, and has other good characteristics (see Table C-6).

A standard 6 V, 4.5 A-hr configuration maintains 5.5 V output for approximately 1 hr at the average 2.1 A drain for the first tap supply and maintains required voltage during current peaks.

Two additional 6 V, 1 A-hr configurations maintain greater than $5.5 + 2(5.5) = 16.5$ V for over 1 hr at the 0.38 A average drain for the second tap.

Another two of these same batteries maintain greater than $16.5 + 2(5.5) = 27.5$ V for the final tap.

Therefore, 5 batteries are required, with the weight and cost shown in Table C-7.

5. Depression Angle Sensor

The depression angle sensor is an off-the-shelf damped pendulum with potentiometer angle pickoff. Figure C-21 shows one candidate.

Table C-6. Electrical Characteristics of Secondary Batteries

| | Gelled-electrolyte lead-acid | Nickel-Cadmium | Silver-Cadmium | Silver-Zinc |
|--|---------------------------------------|--------------------------------|--------------------------------|--------------------------------|
| 1. Energy output Watt-hours per lb Watt-hours per in. ³ | 9 1.1 | 12 to 16 1.2 to 1.5 | 22 to 34 1.5 to 2.7 | 40 to 50 2.5 to 3.2 |
| 2. Nominal cell voltage | 2.12 | 1.2 | 1.1 | 1.5 |
| 3. Cycle life | 200 to 500 | 500 to 2,000 | 150 to 300 | 80 to 100 |
| 4. Temperature range Store Operate | -76 to 140° F -76 to 140° F | -40 to 110° F -20 to 140° F | -85 to 165° F -10 to 165° F | -85 to 165° F -10 to 165° F |
| 5. Shelf life at 68° F to 80% of capacity | 8 months (with lead-calcium grids) | 2 weeks to 1 month | 3 months | 3 months |
| 6. Internal resistance | low | low | very low | very low |
| 7. Discharge curve | sloping | flat | flat | flat |
| 8. Relative cost, rated on a scale of 4 for maximum | 1 | 2 | 4 | 3 |

Table C-7. "Gel" Cell Optional Design

| Battery Type | Quantity | Weight | Cost (100 quantity) |
|---------------|----------|---------|---------------------|
| 6 V, 4.5 A-Hr | 1 | 2.30 lb | \$11.75 |
| 6 V, 1.0 A-Hr | 4 | 0.63 lb | \$ 6.33 |
| Total | 5 | 4.82 lb | \$37 |

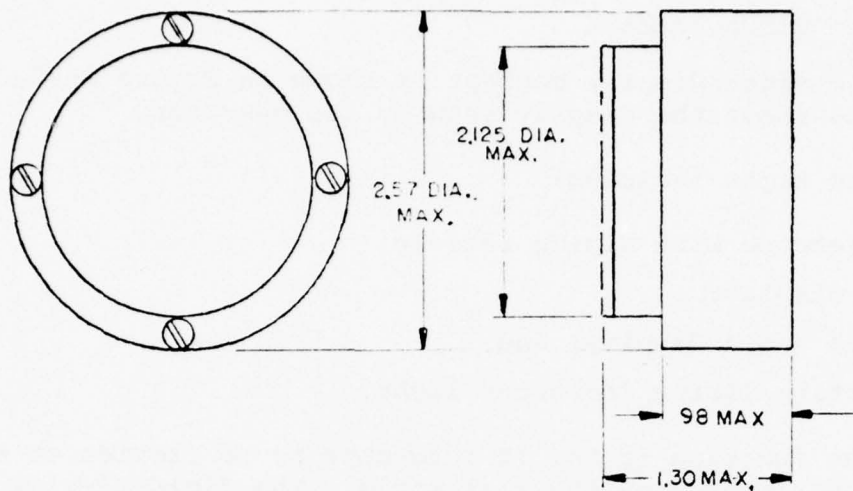

P3265

An economical standard pendulum available from stock that provides unequalled precision and performance for its cost.

- Viscous damping
- 0.2° resolution
- Service life over 10^6 cycles

SPECIFICATIONS:

| | |
|-------------------|--|
| Power dissipation | 0.5 watt at +130°F |
| Center tap | ±0.25% of total electrical travel from theoretical electrical center |
| Accuracy | ±1.0% static error band |
| Damping | 0.1 to 0.5 damping ratio from +20°F to +130°F |
| Natural frequency | 3.2 Hz |
| Temperature | |
| Storage | -65°F to +160°F |
| Operating | +20°F to +130°F |
| Weight | 6 ounces maximum |
| Sealing | no leakage at 24 in. of HG vacuum |

Figure C-21. Depression Angle Sensor

6. Sight/Display

The sight/display concept is shown in Figure C-22, and Figure C-23 shows the display seen by the operator.

The sight includes:

- A 1X telescope with aiming reticle;
- Compass display;
- Kill scan angle display; and
- Beam setting/lasing indicator light.

The function of the 1X telescope is to provide an aiming reticle superimposed on the real world. The field-of-view (FOV) of the telescope is smaller than the scan angle ($\pm 30^\circ$ maximum in azimuth), but the operator has wide angle vision with his unaided left eye. The narrower FOV seen with his right eye through the telescope serves to provide a common real-world reference for both eyes; that is, independent wander of the eyes is avoided. Therefore, aiming is performed with both eyes open, providing wide FOV and a far-focused aiming reticle.

A compass is incorporated in the sight and through beam-splitting is superimposed on the telescope image. Further beam-splitting provides a scan angle display superimposed on the telescope image. The display is achieved with motor-driven cross-hairs. Ambient illumination of the compass and scan angle display is used to provide a display brightness competitive with the telescope scene image.

An LED incorporated with the telescope aiming reticle provides the indicator for beam divergence adjustment and lasing (pulsing light).

The sight eyepiece sets above the remainder of the sight to allow unobstructed azimuth FOV for the left eye and adequate elevation FOV. The telescope design is a standard erect image design. The 1X requirement allows small aperture. FOV is $\pm 6^\circ$. The eyepiece is a standard wide angle Erfle to provide full scan angle display.

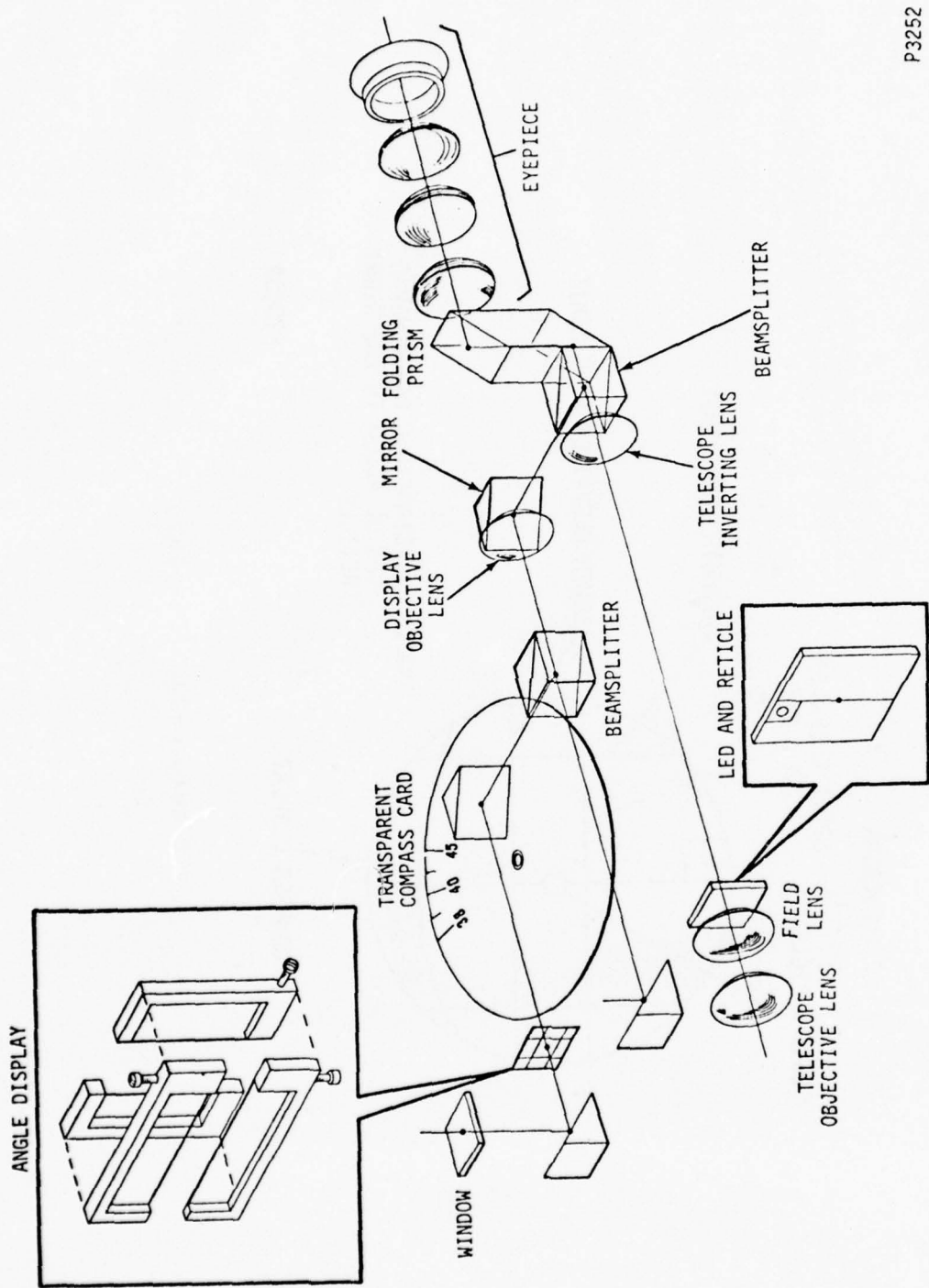

P3252

Figure C-22. Sight Optical Schematic

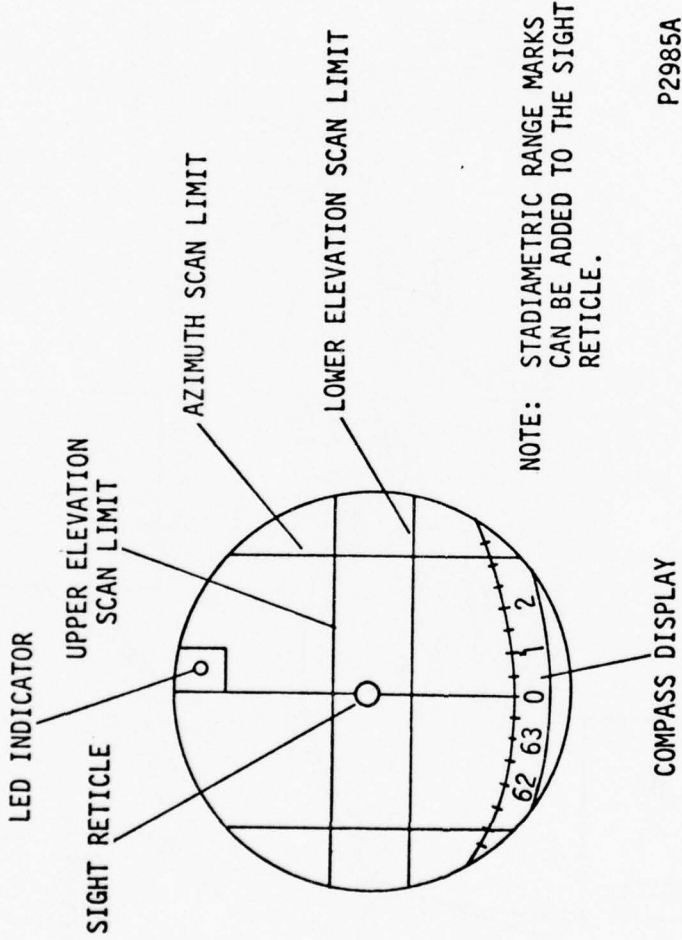

Figure C-23. Display

Beamsplitters, mirrors, and a separate objective lens focus the compass card and the scan angle cross hairs onto the eyepiece front focal plane, thereby providing a far focus display image superimposed on the scene. The compass card is transparent with black military mil gradations and is floated in a transparent liquid. A window above the edge of the card allows ambient illumination of the compass. The azimuth scan angle display is produced by a pair of fine black wires supported on separate yokes which are differentially driven by a common screw. The elevation display employs similar yokes which are independently driven. Although the azimuth and elevation wires must necessarily be in different planes, the fineness of the wires produces negligible focus difference. A window and 90°-fold mirror allows ambient illumination of the angle display.

7. Configuration

The laser design concept is shown in Figure C-1 (Page C-8).

The laser is designed for rapid "hand-held" use when desired. Therefore, handles and handle-integrated controls are provided, and certain information is displayed in the sight (the compass and LED displays in the sight are necessary for hand-held operation). A cheek or head rest will be provided for comfortable, steady aiming. Because the estimated weight of the laser is projected to be 10 lb, support is necessary for hand-held operation. Therefore, a telescoping monopod is considered for attachment to the bottom of the laser. The monopod would have a ball joint for free positioning of the laser and would pivot flat against the bottom of the laser for carrying and transport (in a soft, padded carrying bag).

The laser can also be tripod-mounted, when possible, for maximum aiming stability.

All controls that are set before power turn-on and aiming are positioned on the left hand side of the laser. The power switch and post-aiming beam setting controls are on the right hand side. The thumbwheel controls that permit override of the nominal automatic setting of scan pattern are integrated in the handles, as are the data enter and fire buttons.

An integral battery pack is shown. The battery is divided into two packs because one group of cells requires more frequent replacement than the other. The battery pack simply plugs into the laser. Battery push-to-test indicators are provided for each pack.

Internally, the gimbaled mirror is located at the bottom of the laser so that the permanent magnets in the DC torquers will produce minimal interference with the compass. Some perm-alloy shielding will be required to trap residual stray fields. The optical path is folded to produce the smallest possible configuration. The GaAs diode array with optical integrator and iris is mounted on a rack and pinion mechanism to achieve defocus control. A rigid bed is provided for the optical components.

As noted in Figure C-1 (Sheet 3), two large printed circuit boards are stacked on the left side and a third board is located at the back of the laser. The laser driver must be located close to the laser diode array and is therefore mounted on the side of the sliding defocus mechanism, moving with the diode array.

The sight/display is an independent module attaching to the laser housing. Electrical connection for the LED display, night illumination, and angle display position feedback is provided. In addition, three mechanical connections provide the flex-drive for the angle display. The three small permanent magnet motors for the angle drive are located at the bottom of the laser to avoid interference with the compass. Here, permalloy shielding will be required to trap leakage fields. Twisted leads are used to carry currents and special precautions in board layout are used to minimize magnetic fields. One ground-point to the case is used, and each compass/laser assembly will be individually compensated.

An area on top of the laser allows for night sight mounting.

The laser is sealed to provide a dry atmosphere for the optics. The sight is separately sealed.

The laser housing measures 8 in. W x 10 in. H x 12 in. D. The sight increases height to 13 in. and handle-to-handle width is 14 in.

Weight is approximately 10 lb.

E. PERFORMANCE

1. Eye Safety

Laser eye safety criteria are defined in TB MED 279, "Control of Hazards to Health from Laser Radiation", 30 May 1975. Figures B-1 and B-2 of that reference give the eye safe criteria for looking into collimated radiation (which produces a "point" source at the retina) and for looking at an extended source (which produces an extended image at the retina). The energy radiance from an extended source produces an energy density at the eye according to the equation:

$$M_I = L_I \left(\frac{\pi}{4} d_s^2 \right) \left(\frac{1}{\ell} \right) = \frac{\pi}{4} L_I (\ell \alpha)^2 \left(\frac{1}{\ell} \right) = \frac{\pi}{4} L_I \alpha^2$$

where

M_I = energy density at the eye ~ J/cm²

L_I = energy radiance by an extended source ~ J/cm²/sr

d_s = source diameter

ℓ = viewing distance

α = angular subtense of source ~ rad

Figure B-3 of TB MED 279 has used this relationship to define the α at which Figures B-1 and B-2 are consistent. For convenience, Figures B-1 through B-3 of TB MED 279 are reproduced here as Figures C-24 through C-26.

Now TB MED 279 has chosen to simplify calculations by using Figure C-26 as the criterion to define an extended source for which the eye safety criteria of Figure C-25 apply. However, this simplification can lead to unrealistic conditions as shown in the following.

The GaAs source described for the preceding laser design subtends an angle of

$$\alpha = \frac{0.260}{12} = 21.7 \text{ mr}$$

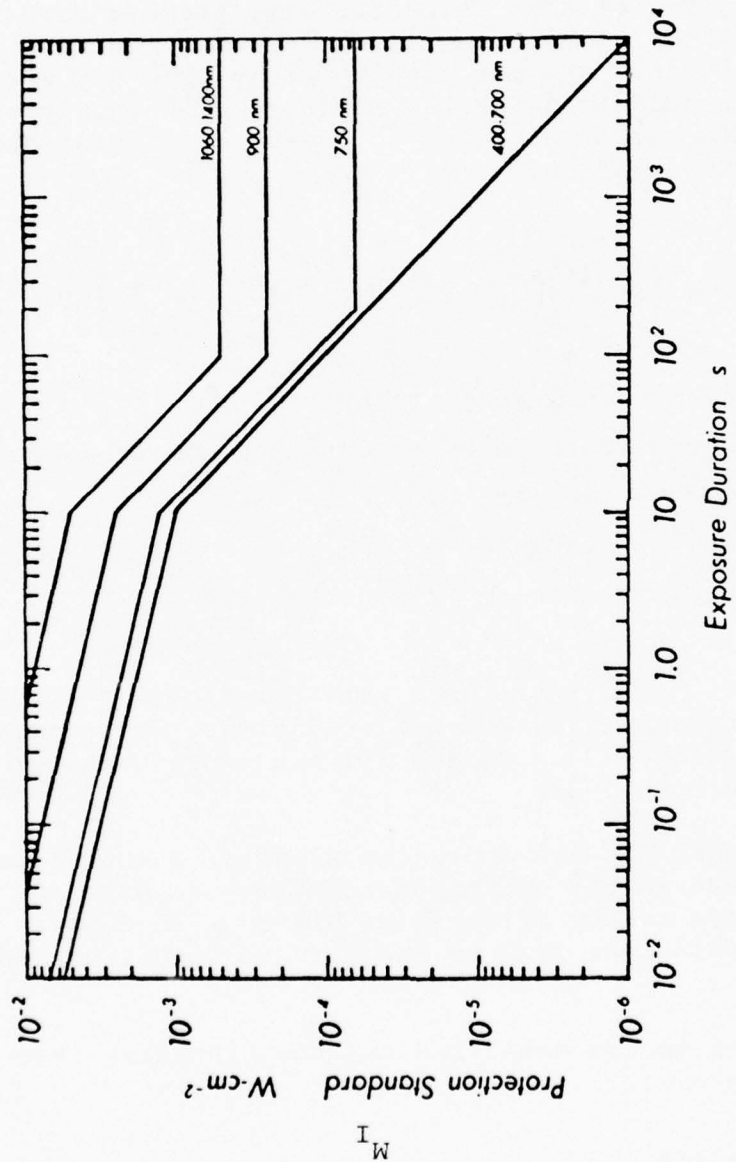

Figure C-24. Protection standard for intrabeam viewing of pulsed visible (400-700 nm) laser radiation. Protection standards for intrabeam viewing of pulsed IR-A (700-1400 nm) laser radiation are obtained by multiplying value in graph by C_A .

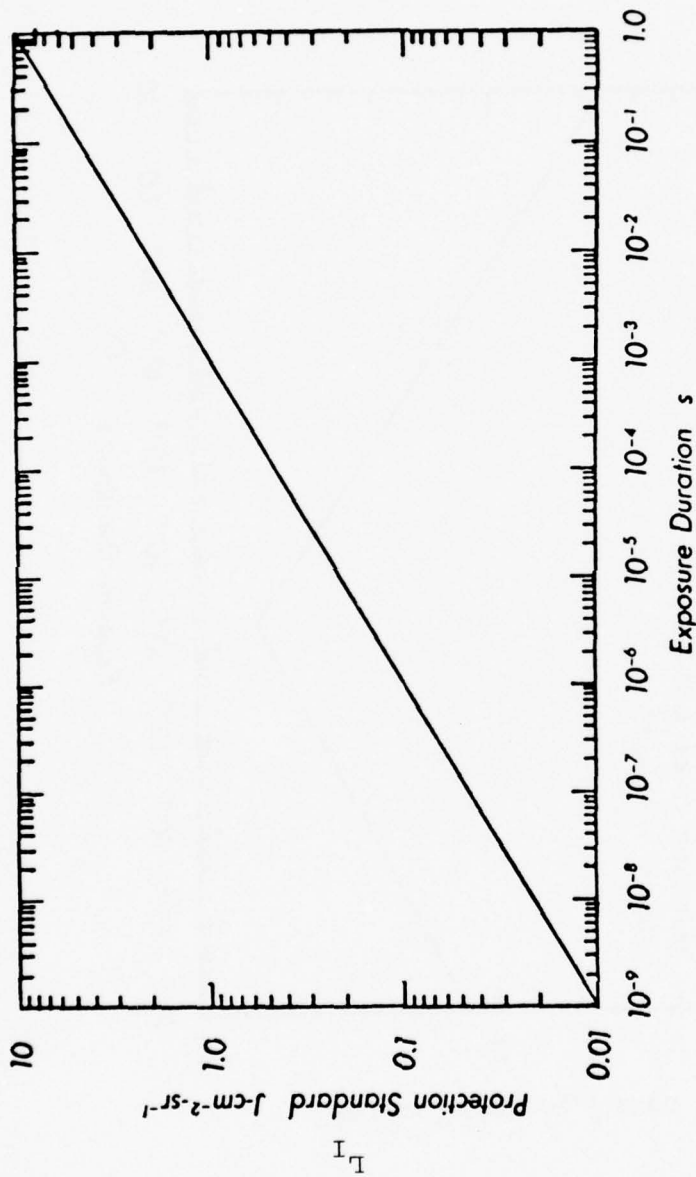

Figure C-25. Protection standard for extended sources of diffuse reflections of pulsed laser radiation (400-700 nm). To obtain protection standard for wavelengths 700-1400 nm, multiply by C_A .

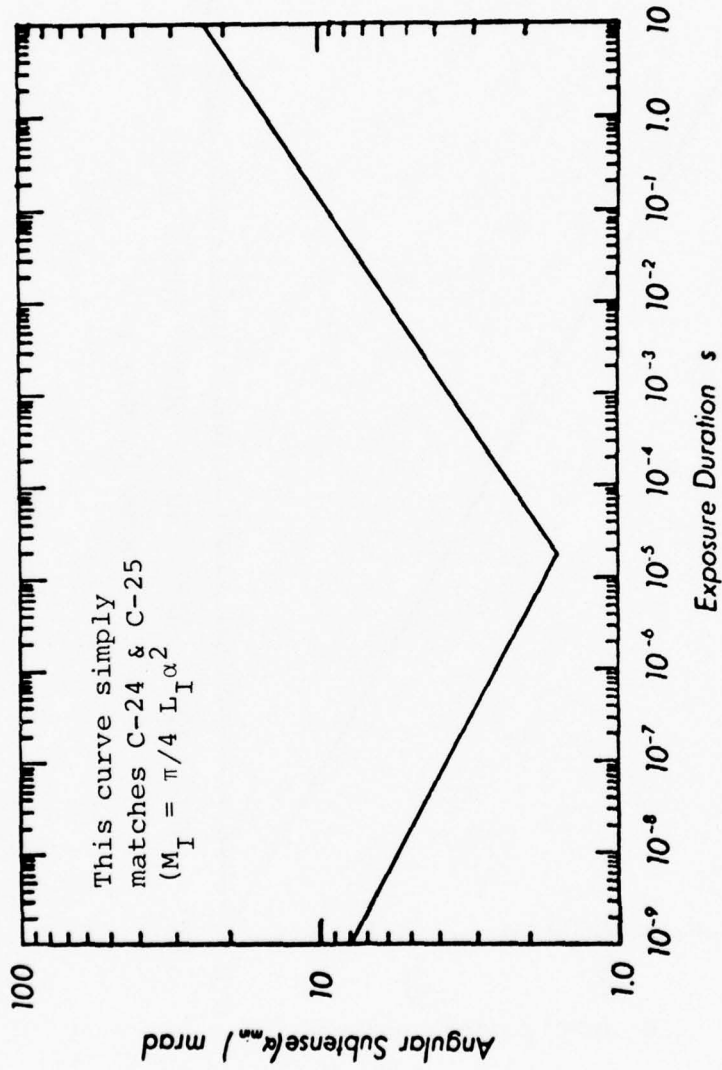

Figure C-26. Limiting angular subtense of an extended source (α min). Sources whose angular subtense are less than α min are considered collimated; those greater or equal to α min are considered extended sources.

when the source is at the infinity focus position and the eye is at the lens. According to Figure C-26, this subtense allows exposure times to 8 sec. (The actual lasing time can be longer considering the unlikely situation of a man staring fixed into the transmitted beam at short range for such a long period and the fact that long lasing times are accompanied by large angular scanning of the beam.) If the iris is used to reduce the source subtense (that is, beam divergence), Figure C-26 would no longer allow the extended source criteria of Figure C-25 to be used for long exposure, but in fact the uniform energy density over the source area produces no greater eye safety problem for smaller subtense because the energy density at the retina does not change. The same condition arises for a far field observer. Although the apparent source subtense angle remains constant at all ranges because of the infinity focus condition, the observer's eye does not intercept the collimated bundle from each source point and the viewable source subtense can be less than the actual total subtense. Therefore, again Figure C-26 would not allow use of the criteria of Figure C-25, whereas the energy density at the eye has not changed.

Because of this unrealistic constraint and the fact that forced use of the criteria of Figure C-26 would severely constrain performance, the extended source criteria of Figure C-25 will be used.

Two extended source safety criteria must be examined:

- Figure C-25 allows $0.06 \text{ J/cm}^2/\text{sr}$ for single 200 ns pulses. Correcting this by the 2.5 factor for 900 nm wavelength and 0.06 factor for 1,000 pps cue pulse rate (see Figures B-4 and B-5 of TB MED 279), yields a single pulse safety criterion of $0.009 \text{ J/cm}^2/\text{sr}$. For an exposure time of t sec, the total exposure criterion is, therefore,

$$0.009 (1000) t = 9 t \text{ J/cm}^2/\text{sr}$$

- For a total exposure of t sec, Figure C-25 (and Table B-2 of TB MED 279) also specifies an integrated exposure criterion of

$$25 \sqrt[3]{t} \text{ J/cm}^2/\text{sr}, \text{ for } t < 10 \text{ sec,}$$

where the 2.5 wavelength correction factor is again applied.

These two criteria are equal at

$$9 t = 25 \sqrt[3]{t}$$

or

$$t = 4.6 \text{ sec}$$

For $t < 4.6$ sec the most demanding criterion is $9 t$ J/cm²/sr; for $4.6 \text{ sec} < t < 10 \text{ sec}$ the criterion is $25 \sqrt[3]{t}$ J/cm²/sr; for $t > 10$ sec the criterion is constant at 50 J/cm²/sr (Table B-2 of TB MED 279).

For $t < 4.6$ sec the individual pulse safety criterion is 0.009 J/cm²/sr as shown above. For $4.6 \text{ sec} < t < 10 \text{ sec}$ the individual pulse criterion (L_p) is

$$L_p (1000) t = 25 \sqrt[3]{t}$$

or

$$L_p = 0.025 t^{-2/3}$$

which is more demanding than the $t < 4.6$ sec criterion. For $t > 10$ sec the individual pulse criterion is

$$L_p (1000) t = 50$$

or

$$L_p = 0.050/t$$

which is even more demanding than the above criterion. Therefore, the integrated exposure criterion for the longest exposure time is the design requirement for exposures greater than 4.6 sec.

Figure C-5 provides the data necessary to calculate actual source pulse radiance (L_p) of annular sections of the source radiation pattern according to the following equation:

$$L_p = \frac{(P_s t_p / A_s) T_o (\epsilon_{12} - \epsilon_{11})}{(\pi/4) (D_2^2 - D_1^2) / f^2} = \frac{6.18 \times 10^{-4} (\epsilon_{12} - \epsilon_{11})}{\frac{1}{(f/\#)_2^2} - \frac{1}{(f/\#)_1^2}} \text{ J/cm}^2/\text{sr}$$

where

$$P_s = 1000 \text{ W}$$

$$t_p = \text{pulsewidth} = 200 \times 10^{-9} \text{ sec}$$

$$A_s = \pi/4 (0.260 \times 2.54)^2 = 0.342 \text{ cm}^2$$

$$T_o = 0.83$$

$$\epsilon_{11}, \epsilon_{12} = \text{fractional power in a cone of f-number } (f/\#)_1 \text{ and } (f/\#)_2, \text{ respectively (excluding the } f/10 \text{ central blockage)}$$

The source radiance (L_p) is maximum along the optical axis and falls off at angles off-axis; therefore, L_p is maximum at the edge of the central blockage:

$$(L_p)_{\text{max}} = 3.2 \times 10^{-3} \text{ J/cm}^2/\text{sr}$$

According to the eye safety criteria this allows an exposure time of

$$0.050/t = 3.2 \times 10^{-3}$$

or

$$t = 15.6 \text{ sec}$$

This is more than adequate for all scan times, and is really very conservative because:

- The 1,000 pps pulse rate is used only during cue, not during kill;
- The beam is scanning, making it impossible to dwell the extended source image on the retina for these long times; and
- An observer is not likely to look fixedly at the laser for these long times.

2. Range

Range is constrained by visibility. Visibility is normally expressed in terms of meteorological visible range, which is defined as the range at which a 100% contrast object against sky background is reduced to an apparent visible contrast of 2%. McClatchey, et.al. (op. cit.) gives attenuation data for various wavelengths and two visibility conditions. These data yield the following atmospheric transmission expression for the 0.9 μm GaAs wavelength:

$$T_A = e^{-2.4 R/V_{1.0}}$$

where

R = range

$V_{1.0}$ = met. range (as defined above)

The range equation is given as equation (3) in D.2.:

$$\begin{aligned} R^2 &= 1.24 \times 10^{10} T_A \sim \text{cm}^2 \\ &= 1.24 \times 10^6 T_A \sim \text{m}^2 \end{aligned}$$

Therefore,

$$R = 1.11 \times 10^3 e^{-1.2 R/V_{1.0}} \sim \text{m} \quad (4)$$

The solutions for this equation are plotted in Figure C-27, which shows that the 1 km maximum range can be achieved in hazy to clear visibility. The figure also shows that $V_{1.0}$ must exceed R for $V_{1.0} > 330 \text{ m}$.

If a more realistic condition of 25% object contrast is considered, R now exceeds $V_{0.25}$ for $V_{0.25} < 500 \text{ m}$, as shown in Figure C-27. The relationship of $V_{0.25}$ to $V_{1.0}$ is derived as follows:

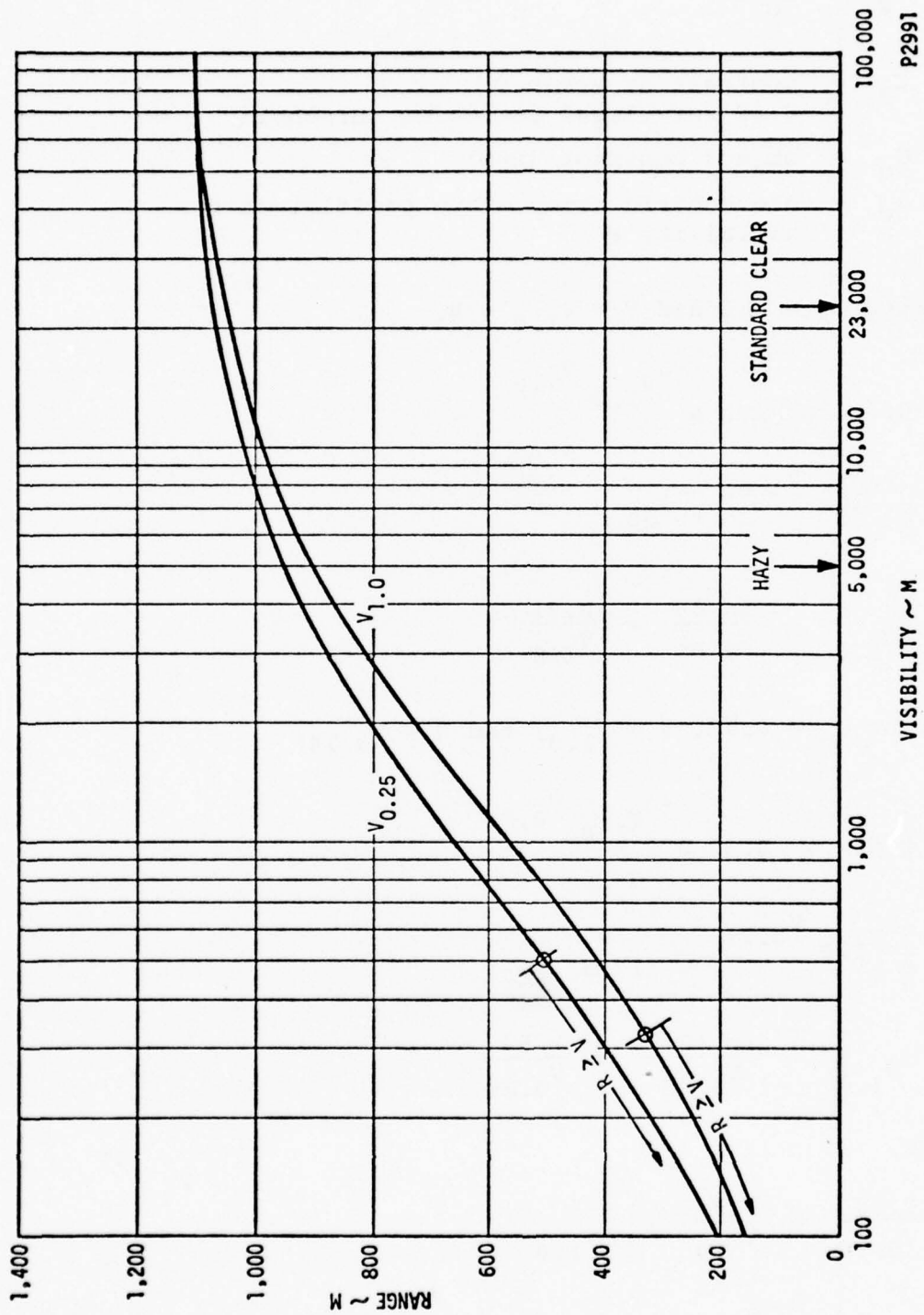

Figure C-27. Range Performance

$$C_R = C_O e^{-\sigma_V R}$$

where

- C_R = contrast at range R
- = 0.02 for visual detection threshold
- C_O = object contrast (R=0)
- σ_V = atmospheric attenuation coefficient for visibility V

Considering $C_O = 1.0$ and $V = V_{1.0} = R$,

$$0.02 = 1.0 e^{-\sigma_{V_{1.0}} V_{1.0}}$$

$$e^{\sigma_{V_{1.0}} V_{1.0}} = 50$$

$$\sigma_{V_{1.0}} = \frac{\ln 50}{V_{1.0}} = \frac{3.91}{V_{1.0}}$$

Considering $C_O = 0.25$, $V = V_{1.0}$, and $R = V_{0.25}$,

$$0.02 = 0.25 e^{-\sigma_{V_{1.0}} V_{0.25}}$$

$$e^{\sigma_{V_{1.0}} V_{0.25}} = 12.5$$

$$\sigma_{V_{1.0}} = \frac{\ln 12.5}{V_{0.25}} = \frac{2.53}{V_{0.25}}$$

Therefore,

$$\frac{2.53}{V_{0.25}} = \frac{3.91}{V_{1.0}} = \sigma_{V_{1.0}}$$

or

$$V_{1.0} = \frac{3.91}{2.53} V_{0.25} = 1.54 V_{0.25}$$

Substituting in equation (4) yields

$$R = 1.10 \times 10^3 e^{-0.779 R/V} 0.25$$

for which the solutions are plotted in Figure C-27.

3. Scan Time

Scan time is the most significant performance parameter for the laser simulation of indirect fire. Scan time is the time to simulate one round or one volley, and to keep this time within a reasonable value has required the use of the highest power GaAs laser diode available as well as optimization of beam divergence through use of the laser's microprocessor.

A simulation can range from a single small round having a kill diameter of 16 m (81 mm mortar) to volley fire into a 300 x 200 m area (artillery battery parallel sheaf). Scan time increases as the scan area increases, and scan time is also affected by operator height above the target area, visibility, and range (the latter two parameters determining beam size).

Figure C-28 shows scan time for the two extreme conditions: 1) smallest caliber single round; and 2) large volley area. For ground operation the depression angle will normally be small (< 0.1 radian). If helicopter-deployed, the depression angle will be at least 0.2 radian (15°) because a hovering or slowly moving helicopter must remain above 400-700 ft (that is, 200 m) for autorotation safety and because the maximum range (clear weather) is 1,000 m; that is,

$$\tan^{-1} \frac{200}{1000} = 0.2 \text{ radian}$$

The curves show that scan times are expected to be less than 2 sec for ground operation, except for the large-area volley simulation in poor visibility where scan time can be 4.5 sec. The curves also show that for helicopter-deployment (or high vantage point ground operation), large area fire simulation demands clear weather and near maximum range if scan times are to be kept small.

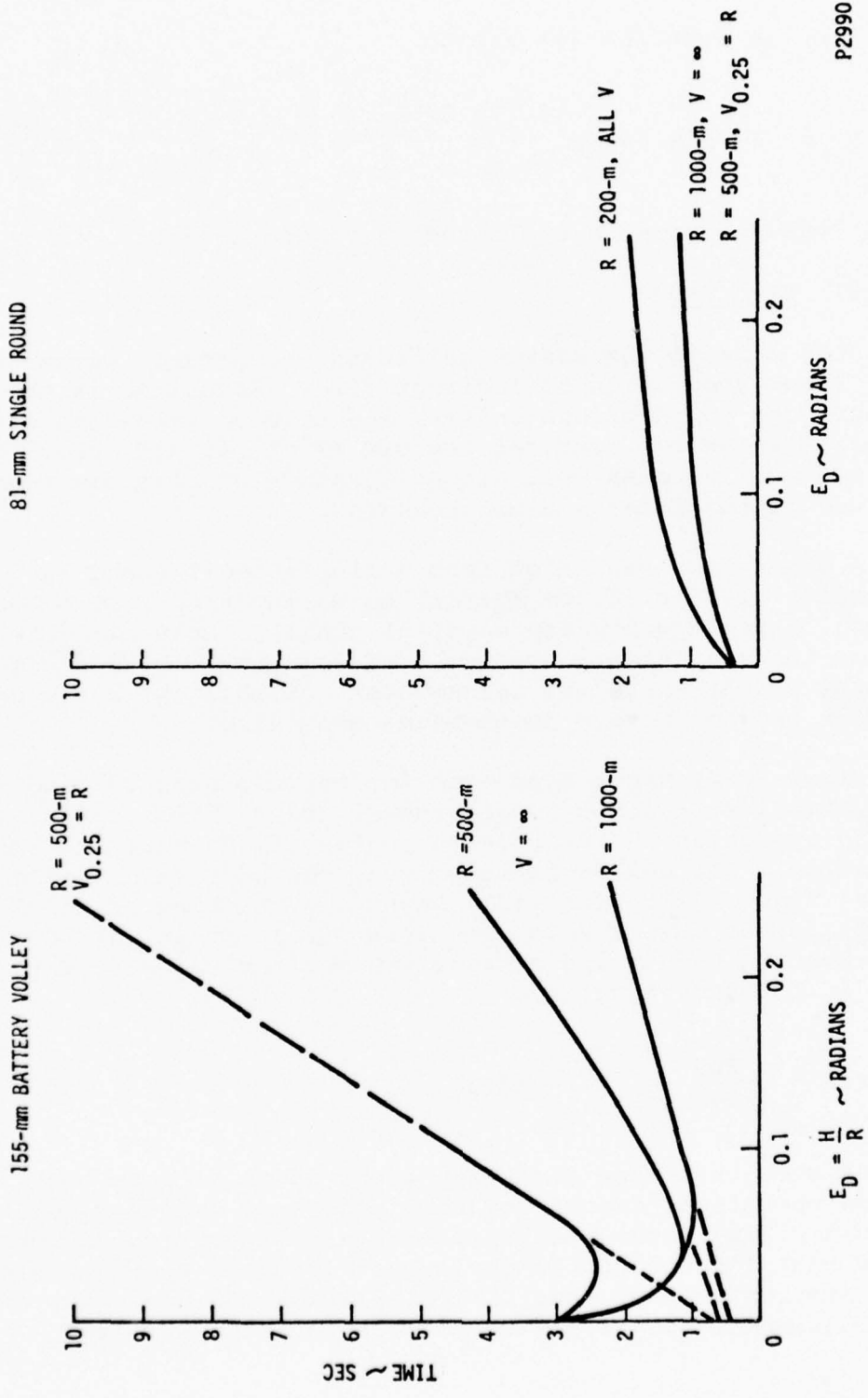

P2990

Figure C-28. Scan Time Performance

Table C-8 gives the beam divergence, gimbal scan angles, and number of scan bars for conditions of Figure C-28. These are the parameters which the laser's microprocessor computes. Standoff range \geq width of cue area is assumed to yield a reasonable footprint (see Figure C-29).

Table C-8. Scan Parameters for Given Simulation Conditions

| Simulation Condition | Visibility (V _{0.25}) ~ m | Range ~ m | Depression Angle, E _D ~ rad | Beam Divergence ~ mr | Kill Scan | | | Cue Scan | | |
|--|-------------------------------------|------------------|--|-------------------------------|-----------|----------|----------|----------|----------|----------|
| | | | | | Az ~ deg | EI ~ deg | No. Bars | Az ~ deg | EI ~ deg | No. Bars |
| 81 mm Single Round 16 m Kill Dia. 116x116 m Cue | ∞ | 232 | 0 0.1 0.25 | 12.2 21.9 51.6 | ±1.7 | 0.5 | 1 | ±26.4 | 0.5 | 1 |
| | | | | | ±1.5 | 0.9 | 1 | ±26.2 | 6.4 | 9 |
| | | | | | ±1.2 | 1.5 | 1 | ±25.9 | 15.7 | 12 |
| | ∞ | 1000 | 0 0.1 0.25 | 2.8 5.1 8.4 | ±0.4 | 0.1 | 1 | ±6.1 | 0.1 | 1 |
| | | | | | ±0.35 | 0.2 | 1 | ±6.1 | 1.15 | 7 |
| | | | | | ±0.3 | 0.3 | 1 | ±6.0 | 2.8 | 10 |
| | 232 | 0 0.1 0.25 | 11.3 21.9 51.7 | Same as V _{0.25} = ∞ | | | | | | |
| | | | | ±0.8 | 0.2 | 1 | ±12.3 | 0.2 | 1 | |
| | | | | ±0.7 | 0.4 | 1 | ±12.2 | 2.4 | 7 | |
| | 500 | 500 | 0 0.1 0.25 | 5.6 10.2 16.7 | ±0.6 | 0.7 | 1 | ±12.0 | 5.9 | 10 |
| | | | | | ±17.1 | 0.2 | 1 | ±28.5 | 0.2 | 1 |
| | | | | | ±16.4 | 1.1 | 2 | ±27.9 | 4.2 | 4 |
| ∞ | 500 | 0 0.1 0.25 | 5.6 53.2 53.2 | ±16.4 | 4.6 | 5 | ±27.9 | 12.1 | 10 | |
| | | | | ±8.5 | 0.1 | 1 | ±14.3 | 0.1 | 1 | |
| | | | | ±8.2 | 0.5 | 2 | ±13.9 | 1.7 | 4 | |
| ∞ | 1000 | 0 0.1 0.25 | 2.8 26.6 26.6 | ±8.2 | 2.2 | 4 | ±13.9 | 5.2 | 8 | |
| | | | | ±17.1 | 0.2 | 1 | ±28.5 | 0.2 | 1 | |
| | | | | ±16.8 | 1.9 | 4 | ±28.3 | 4.95 | 8 | |
| 500 | 500 | 0 0.1 0.25 | 5.6 25.2 25.2 | ±16.8 | 5.4 | 9 | ±28.3 | 12.9 | 19 | |
| | | | | ±16.8 | 5.4 | 9 | ±28.3 | 12.9 | 19 | |
| | | | | ±16.8 | 5.4 | 9 | ±28.3 | 12.9 | 19 | |

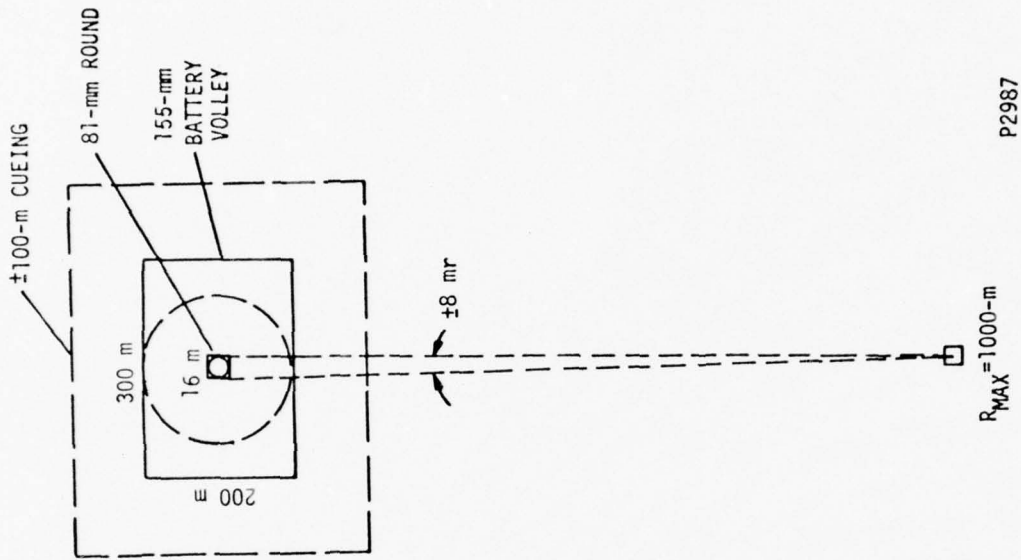

P2987

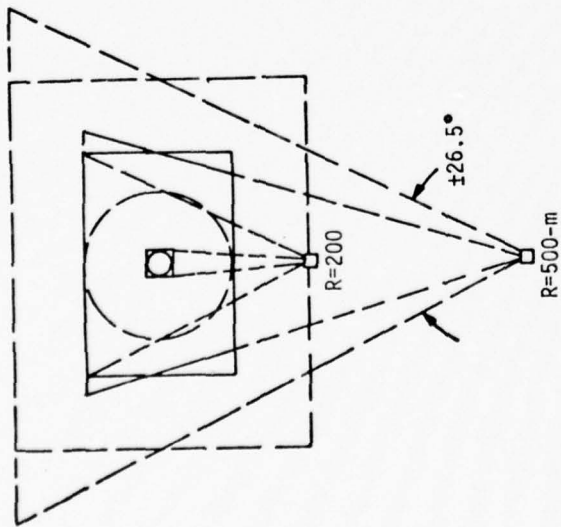

$$R_{MIN} = W_{CUE}$$

$$A_K = \pm \frac{W_K/2}{R}$$

$$A_C = \pm \frac{W_K/2 + 100}{R}$$

Figure C-29. Simulation Footprint

APPENDIX D

V.H.F. TRILATERATION GROUND DESIGNATION SYSTEM

TABLE OF CONTENTS

| <u>Section</u> | <u>Title</u> | <u>Page</u> |
|----------------|--|-------------|
| A | OPERATIONAL REQUIREMENTS/CONSIDERATIONS | D-3 |
| | 1. General | D-3 |
| | 2. Geometry/Terrain and Operational Time | D-3 |
| | 3. Environment | D-4 |
| | 4. Battle Non-Interference | D-4 |
| | 5. Mobility/Reliability/Maintainability | D-5 |
| | 6. MILES System Compatibility/Interoperability | D-5 |
| | 7. Cost Effectiveness | D-6 |
| | 8. Cueing | D-6 |
| B | CONFIGURATION | D-7 |
| | 1. Basic System | D-7 |
| | 2. Advantages/Disadvantages | D-15 |
| C | PRELIMINARY DESIGN | D-17 |
| | 1. Basic Design Factors | D-17 |
| | 2. Propagation/Transmission Times | D-17 |
| | 3. Designation Accuracy/Bandwidth Considerations | D-19 |
| | 4. Clock Rate, Addressing and Delays | D-22 |
| | 5. Modulation Format | D-24 |
| | 6. Receivers | D-24 |
| | 7. Transmitters | D-34 |

LIST OF ILLUSTRATIONS

| <u>Figure</u> | <u>Title</u> | <u>Page</u> |
|---------------|---|-------------|
| D-1 | Deployment of Basic Trilateration Ground Designation System in Simulated Battle Range | D-8 |
| D-2 | Trilateration Mobile Station | D-10 |
| D-3 | Trilateration Master Transmitter and Processor Functional Diagram | D-11 |
| D-4 | Trilateration Designation System Timing | D-13 |
| D-5 | Trilateration Designation System Addressing Diagram | D-14 |
| D-6 | Trilateration Propagation | D-18 |
| D-7 | Signal-to-Noise Ratio Versus Range Error | D-21 |
| D-8 | Delay Shift Register/Coincidence Gate Configuration | D-25 |
| D-9 | Designation Receiver Functional Diagram | D-27 |
| D-10 | Code 2 Pager Schematic | D-29 |
| D-11 | Code 2 Pager Descriptive | D-31 |
| D-12 | Designation Receiver Helmet Mounted Antenna | D-35 |
| D-13 | Maximum Range Size Coverage Area (Azimuth) | D-36 |
| D-14 | Maximum Range Size Coverage (Elevation) | D-37 |

V.H.F. TRILATERATION GROUND DESIGNATION SYSTEM

A. OPERATIONAL REQUIREMENTS/CONSIDERATIONS

1. General

Several important operational requirements for an effective designation system for the Indirect/Area Fire Weapon Effects Simulation System (I/AFWES) must be considered. Some of these requirements appear more important than others -- that is, some characteristics/capabilities may be considered as desired rather than absolutely required. The required and desired capabilities combine to make a low VHF Trilateration designation system attractive for I/AFWES. The operational requirements fall into the following general categories:

- Geometry/Terrain
- Operational time
- Environment (weather, etc.)
- Battle non-interference
- Mobility/Reliability/Maintainability
- MILES Compatibility/Interoperability
- Cost effectiveness
- Cueing

2. Geometry/Terrain and Operational Time

The I/AFWES is required to cover battle areas as large as 15 x 30 km. These areas may be at various places in the world, including the U.S., Europe and Korea. Although typical areas of high battle activity are probably closer to 6x6 km in area, these smaller areas can flow throughout the larger area. At any rate, designation anywhere in the large area with very short or negligible delay times between designations is considered an operational requirement.

Any type of terrain which may be encountered in the above mentioned areas of the world, and the inherent terrain variations to be found there, within areas of 15 x 30 km, must be considered an operational requirement.

Capability in extreme and unusual variations in elevation, within 15 x 30 km areas such as, (low desert to high mountain peak) is considered as desired rather than absolutely required.

For effective operation of a ground RF designation system, it is required that shadowing and multipath be held to a minimum regardless of the terrain.

Ninety-six hour simulated battle exercises are a definite requirement, although seventy-two hour exercises may be more typical. This operational requirement, of course, will affect equipment reliability (up-time) and prime power source fuel supply requirements, as well as dictating night operation requirement.

3. Environment

The environmental requirements are those typical of battlefields in the US, Europe and Korea and temperature and humidity extremes encountered there are definite operational environmental requirements. Operation at temperature extremes of -55 to +130°F must be considered requirements. Operation capability in temperature beyond these extremes is desired.

Operation in high and low humidity, high sun radiation, low and high cloud cover, fog, haze and heavy rainfall (16 mm/hr.) is required. Operation in 25 mm/hr rain (cloudburst) is desired but not necessarily required. Another important requirement is operation in and through screening and other smoke often encountered in battlefield areas.

4. Battle Non-Interference

This very important category of operational requirements encompasses a range of capabilities. These capabilities must allow normal battle operations and procedures. To the greatest extent possible, the I/AFWES should not tend to create artificial situations or detract from realism in training mechanized infantry unit personnel, indirect fire personnel, command and fire direction personnel, and the like. Avoidance of distracting elements such as hovering aerial platforms, controller/umpire personnel, and overly

artificial cues is desirable. Any factors which tend to distract or constrain personnel in performing their duties or in learning to take necessary protective measures should also be avoided. Likewise, operations which tend to artificially pre-warn personnel of an impending strike or proximate strike should be avoided.

5. Mobility/Reliability/Maintainability

The stringent environmental and operational time requirements, as discussed above, dictate a highly reliable and rugged system. A system which is easily maintained in the field and does not require constant attention during operation, transportation or storage is highly desirable.

While a ground-only designation system probably does not require mobility during actual operation (the simulated battle exercise), mobility in reaching desired station locations prior to the exercise, and to move out after exercise completion is an operational requirement. Also, the system should be transportable over long distance by normal army means -- that is, rail, air, ship and self transportation.

The mobility requirement tends to dictate use of trucks, or perhaps tracked vehicles for battle areas in very rugged terrain. These should be of standard, existing design and should require a minimum of modification/retrofit.

The reliability/maintainability requirements tend to dictate use of well developed RF technology.

6. MILES System Compatibility/Interoperability

Compatibility (non-interference) with the MILES is required since direct fire simulation must continue to function normally while I/AFWES is in operation.

No particular interference problems are envisioned between RF transmitters and GaAs lasers. Obviously there will be no interoperability at the carrier electromagnetic energy level, that is -- the MILES 0.904 μm energy detectors will not be energized by RF or Microwave irradiation. Also the GaAs laser energy will not be received by RF/microwave receivers.

Receiver equipment sharing (interoperability), to the extent possible, is desirable. This is particularly true of receivers/decoders carried by personnel since space, weight and power considerations for personnel carried equipment is at a premium.

Some commonality in receive equipment can probably be achieved by employing portions of the MILES receivers/decoders at video (pulse), and logic (information) levels. This is an area requiring detailed study.

7. Cost Effectiveness

A high degree of cost effectiveness is required. Equipments already in inventory should be employed to the extent possible. This includes transmitters, transceivers, transport vehicles, computation equipment and interface equipment.

Required computations should be simple and easily accomplished with existing military computers, with minimal new software requirements. Alternatively, a newly designed, inexpensive, fixed program mini computer could be employed. Costly, multiple, read time, precision position location systems, which must be continuously operated throughout the exercise should be avoided.

As discussed previously, high reliability and simple maintainability are required and this is an important contributor to low cost of operation and maintenance over the period of years of ownership.

A VHF trilateration system is compatible with achieving the cost effectiveness goals discussed above. In addition it would employ only one transmitter (master station) and two transceivers (slave stations). Multilateration systems employing much higher frequencies (for example, microwave) would tend to require more stations because of complete dependence on line of sight transmission and directionality of transmission.

8. Cueing

Audio and visual cueing is required in the I/AFWES to lend realism to simulation fire and to facilitate player learning process, (troops learning to avoid incoming artillery or mortar rounds, and FOs learning to adjust fire).

Audio cueing to individual players on foot or in mechanized equipment can easily be accomplished with a trilateration designation system by employing small audio devices such as those employed in the MILES or IDFSS. Either of these already developed existing devices could be employed.

They would be activated by the coincidence of the three trilateration signals, designating a hit or near hit. Differences in audio tones, sound amplitude, and the like, could be employed to indicate direct or proximate hits, based on how nearly simultaneous the three signals arrive at a particular receiver. Remote audio cueing is somewhat more of a problem and further study is required to synthesize suitable concepts in this area.

Effective visual cueing in the I/AFWES remains a problem with an RF Trilateration system as it does with other designation concepts. The viability of visual cueing concepts and ideas associated with trilateration and other designation systems will depend on trade-offs between realism, complexity and cost. (How much is the user willing to expend in cost and complexity to achieve realism?) This is particularly true of remote visual cueing requirements.

B. CONFIGURATION

1. Basic System

The basic trilateration designation system consists of three truck (or tracked vehicle) mounted stations deployed essentially as shown in Figure D-1 and controlled by the simulation net control station.

Relative deployment is not critical but positions of the stations must be accurately known with respect to each other and the coordinates of the battlefield range. This implies an initial survey or use of a sighting ring and/or other sighting (range and bearing) equipment. The latter can probably be employed for ranges where a landmark position is accurately known with respect to map coordinates.

From the standpoint of convenience and flexibility it would be desirable to be able to place the stations without regard to terrain features. However, better performance will be achieved and antenna height requirements minimized by selectively placing stations to take advantage of terrain high places, to achieve line-of-sight (LOS) to most instrumented personnel and vehicles.

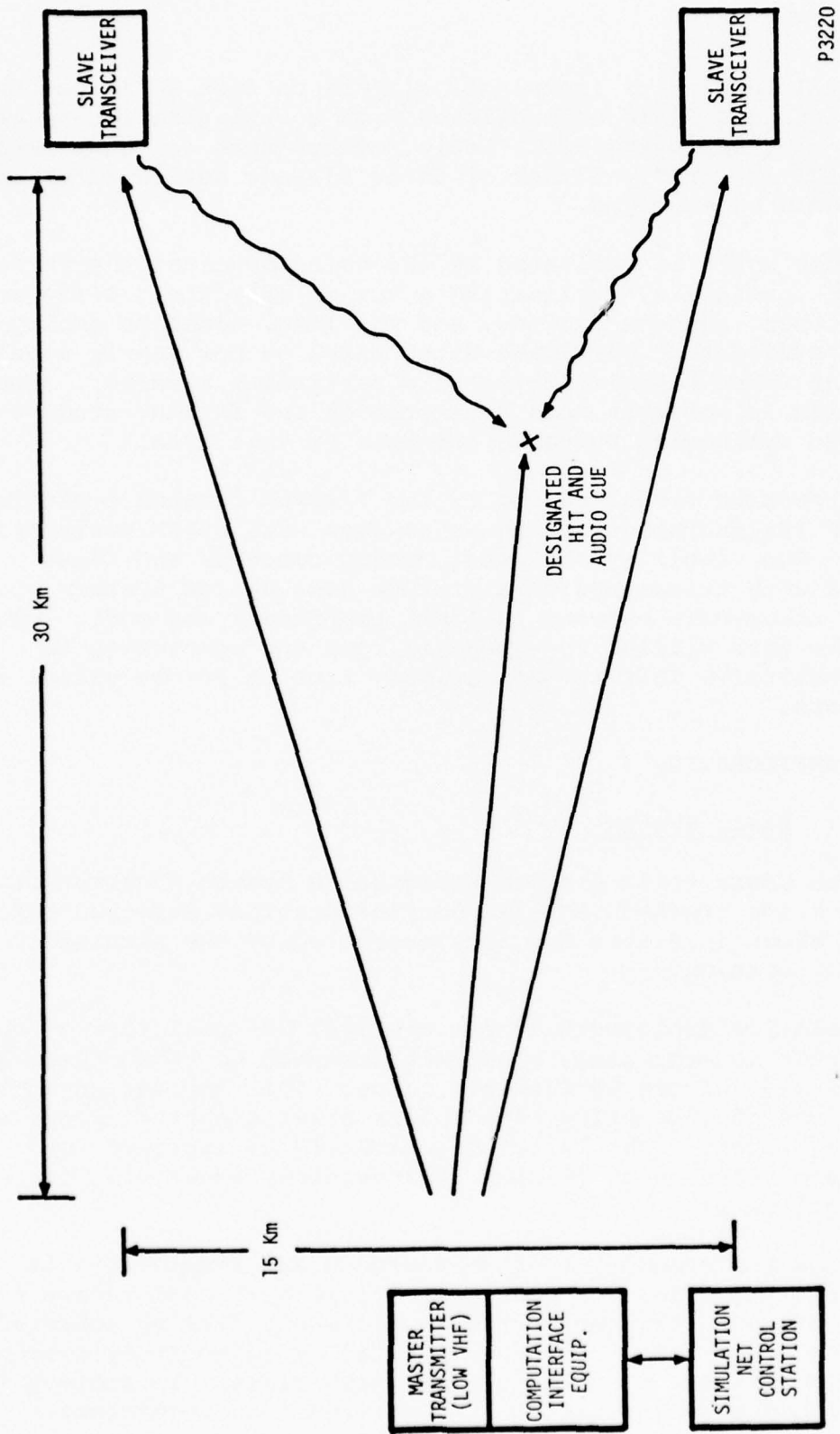

P3220

Figure D-1. Deployment of Basic Trilateration Ground Designation System in Simulated Battle Range

Various propagation studies in the past and empirical data indicate that ground wave occurs in the frequency region of 30 to 200 MHz, but for best performance in many terrain situations, LOS is important since the space part of the ground wave propagates much better than the surface part - such as in commercial television.

Figure D-2 is a conceptual drawing of a truck mounted master or slave station. Various other configurations are possible, including towed vehicles. The antenna elevating mechanism would be similar to currently available commercial, hydraulically powered Hi-reach devices. It would fold down when not in use. Other elevating systems, such as Storable Tubular Extendable Members (STEM) are available.

Basic configuration of the master transmitter and processor is shown in Figure D-3. The processor determines the proper delay times between the three transmissions required to achieve designation at a given location, that is -- between transmissions to first and second slave stations and in transmission directly to the designation receiver. These delays include propagation time differences and two fixed delays which accomplish the following:

- Prevents confusion at the designation receivers, which would occur if the signals actually arrived simultaneously; and
- Prevents simultaneous master station transmission to both slaves when propagation paths are equal.

The fixed delays are reinserted by the receivers to achieve the designation time coincidence. All timing is thus accomplished by the master station. The slave stations are simple transceivers which transmit immediately upon receipt of a properly addressed signal from the master.

Thus, three signals are transmitted by the master for designation. The first, a coded address to the slave for which the propagation path from master to slave to designation point is greatest. The second, an address to the second slave and the third transmission is to the designation receiver. The propagation path from master to designation receiver is always the shortest of the three paths.

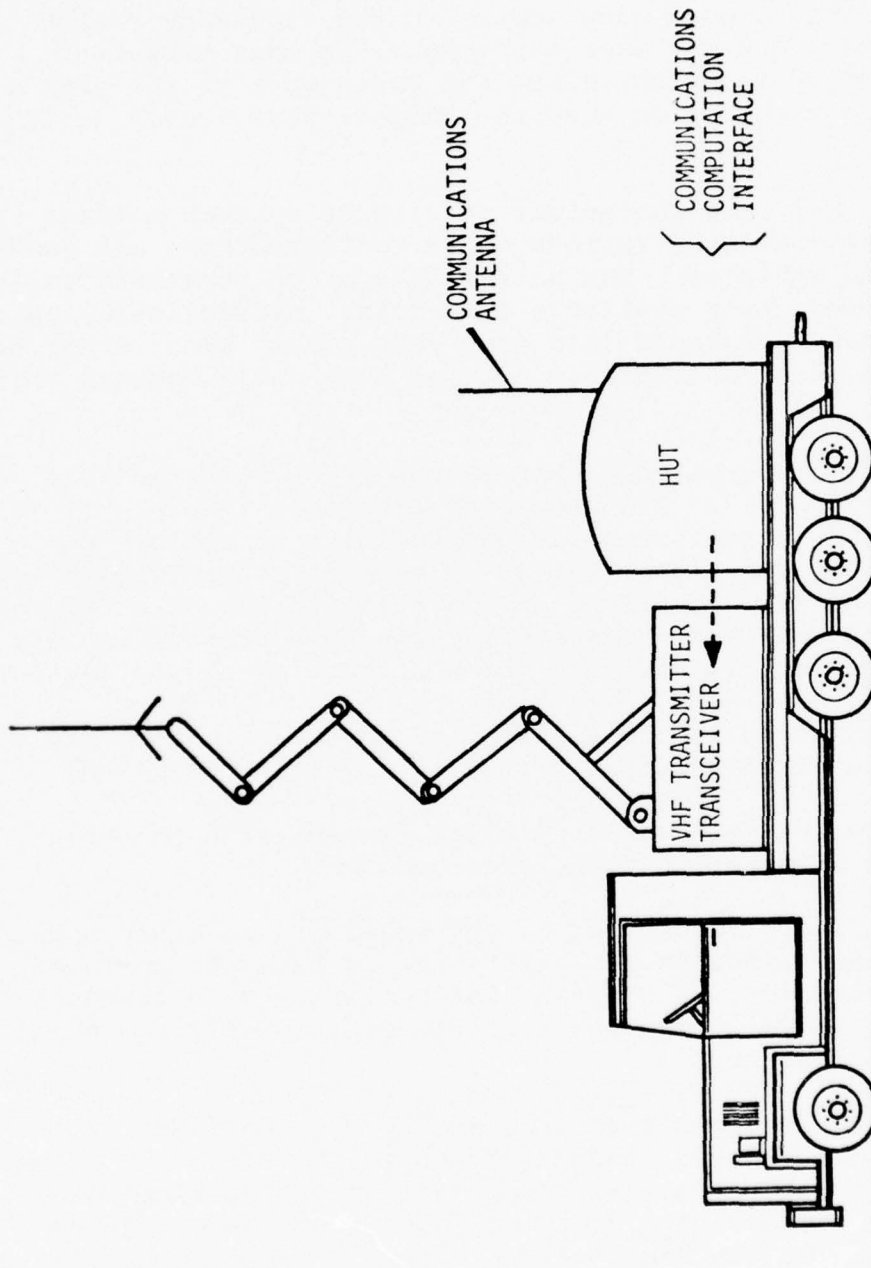

P 3221

Figure D-2. Trilateration Mobile Station

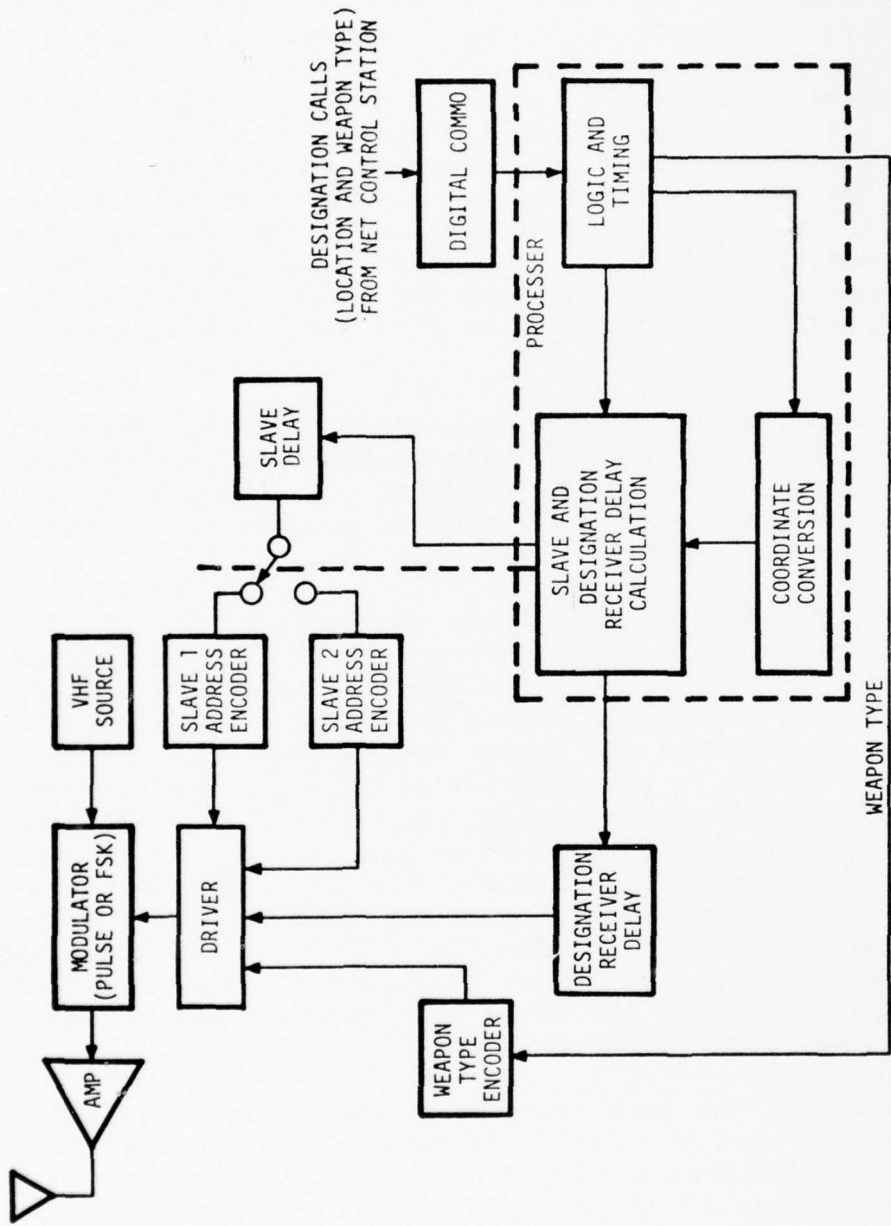

P3222

Figure D-3. Trilateration Master Transmitter and Processor Functional Diagram

The designation receivers may not require an address if a clear channel is employed or if the trilateration signal is significantly higher in amplitude than any possible interfering signal. In this case, only a single, narrow pulse need be transmitted from the slaves and master station for designation. If designation receiver address is employed only one address need be employed for all three designation transmissions and for all designation receivers. The fixed delays (discussed previously) will prevent designation reception "confusion" even if a designation address is employed. It should be noted that the more time spent on addressing, the longer the fixed delays must be since in a specific geometric situation one of the fixed delays minimum is constrained by address time. This will be shown subsequently in Section C-4.

Following its designation transmission to the designation location, the master station transmits weapon type information. A receiver which is in the proper location for designation (three signal coincidence) to occur, will receive and decode the weapon type information. Any other receiver will not.

Figures D-4 and D-5 illustrate the complete system addressing and timing. It should be noted that the slave station transmitters should be basically the same as the master transmitter in so far as transmitted power and antenna are concerned. The only thing required of the master transmitter which is not required of the slaves is transmission of a longer digital (or other encoding) signal giving weapon type information. However, the slave station transmitters would be capable of also transmitting that message if properly driven. On the other hand, the slave stations must have receive and address decoding capability which the master does not require. While there are detailed trade-offs involved, it seems judicious to employ the same basic (complete) transceiver system for all stations, thus allowing any mobile station to be used as a master or slave.

The computation, interface and communications equipment could be a modular unit housed in a standard small shelter (or hut), which could be placed on any mobile station being used as the master. Thus complete interchangeability could be achieved for purposes of convenience and maintenance.

The slave stations would be unattended and probably solar powered. The master station could also be fully automatic but operational status should probably be monitored.

D = DESIGNATION POINT
 M = MASTER TRANSMITTER
 S₁ = SLAVE STATION 1
 S₂ = SLAVE STATION 2
 t_{R1} = TIME OF PROPAGATION M TO S₁ TO D
 t_{R2} = TIME OF PROPAGATION M TO S₂ TO D
 t_D = TIME OF PROPAGATION M TO D
 Δ_{1-2f} = FIXED DELAY BETWEEN M TRANSMISSION TO S₁ AND S₂
 Δ_{2-Mf} = FIXED DELAY BETWEEN M TRANSMISSION TO S₂ AND D
 S_{1T} = TIME OF M TRANSMISSION TO S₁
 S_{2T} = TIME OF M TRANSMISSION TO S₂
 D_T = TIME OF M TRANSMISSION TO D
 Δ_{S2} = t_{R1} - t_{R2} + FIXED DELAY TO PREVENT CONFUSION
 Δ_D = t_{R2} - t_D + FIXED DELAY TO PREVENT CONFUSION

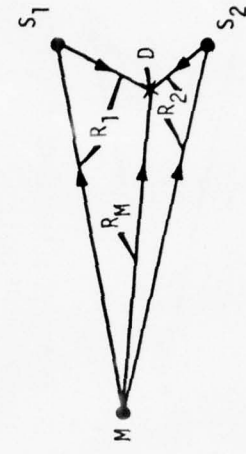
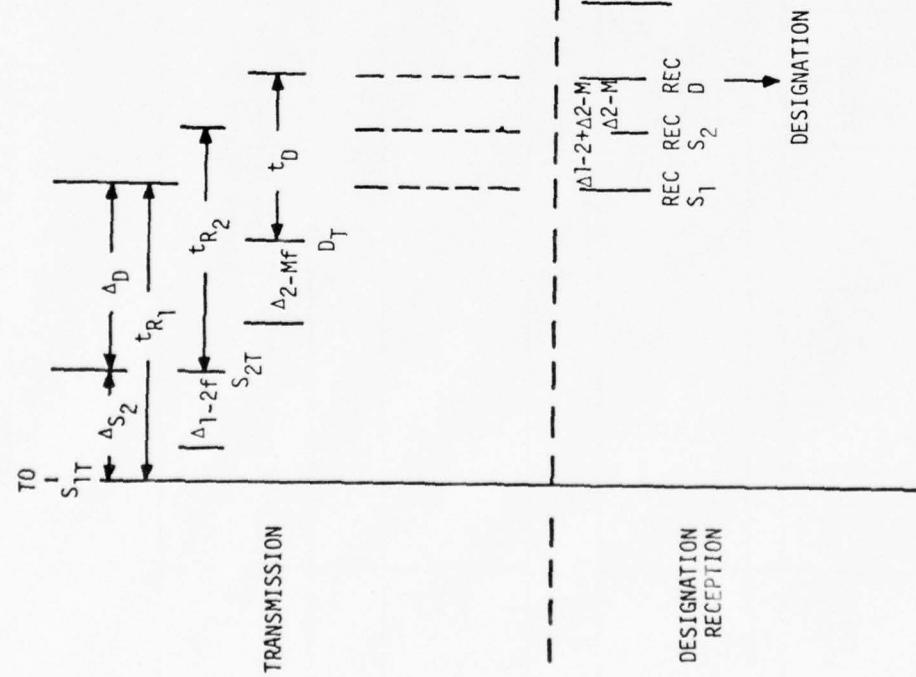

NOTE: S₁ IS ALWAYS THE SLAVE STATION ASSOCIATED WITH THE LONGEST PATH (R₁).

P3223

Figure D-4. Trilateration Designation System Timing

$$\Delta S_2 = (t_{R1} - t_{R2}) + \Delta_{1-2} \text{ FIXED}$$

$$\Delta D = (t_{R2} - t_{RD}) + \Delta_{2-M} \text{ FIXED}$$

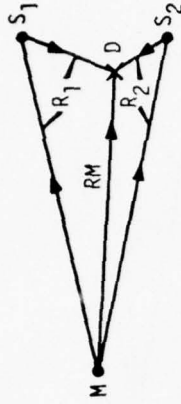

NOTE: S_1 IS ALWAYS SLAVE ASSOCIATED WITH LONGEST PATH (R_1).

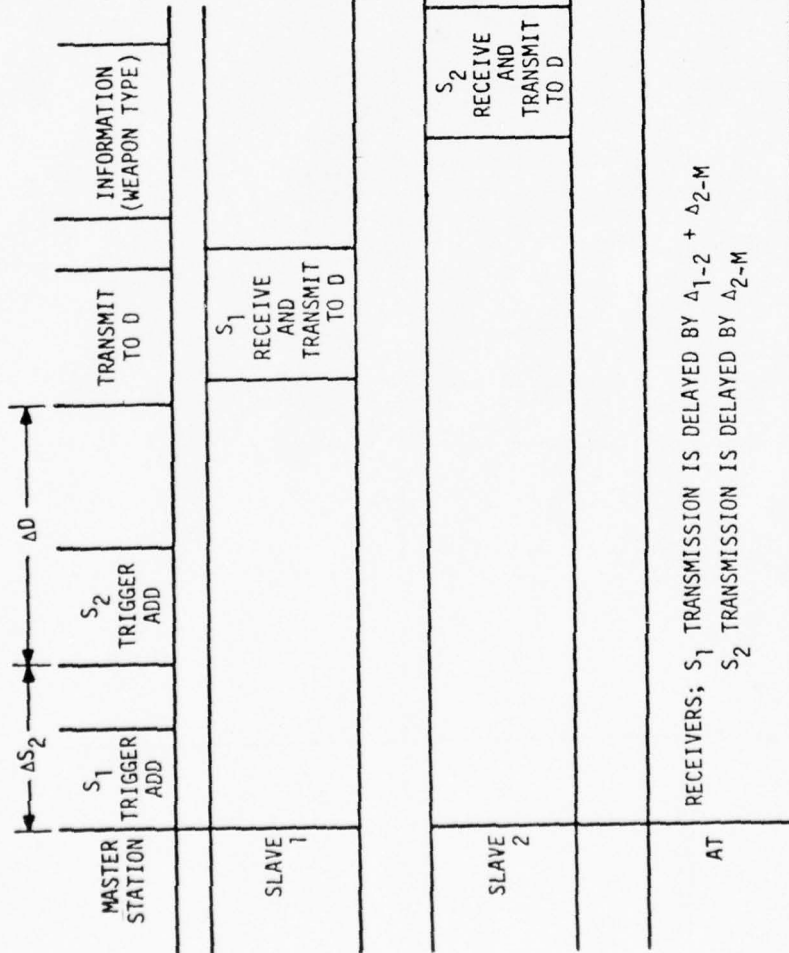

P3224

Figure D-5. Trilateration Designation System Addressing Diagram

2. Advantages/Disadvantages

The basic Trilateration Ground Designation System, as configured in this section, has the following advantages:

- Will operate continuously in any terrain, any climate, any weather and any battlefield peculiar conditions, including dense smoke.
- Does not require airborne platforms.
- Does not require continuously operating precision location devices such as PLRS, RMS, PRRS, Beacons Inertial navigation systems, Doppler navigation systems or any other navigation systems.
- Requires only three stations. (One master transmitter and two slave transceivers).
- Is highly mobile (truck or tracked vehicle mounted), but does not need to move during simulated battle exercises.
- Is easily transportable by air, rail, ship or road (self transportation).
- Is non-interfering with normal battle activities and procedures.
- Is compatible (non-interfering) with the MILES, and could be interoperable with MILES at the video (pulse) and logic (information) level, if proper account of this is taken in MILES engineering development.
- Is highly reliable and should require little maintenance, since VHF technology and equipment is already in a long term, highly developed state, that is -- transmitters and transceivers are like low power, mobile TV stations, and designation receivers employ technology based on miniaturized commercial communication systems such as paging and radio telephone systems. Overlaying this is the whole military ruggedized communications technology state of the art.

- Can be cost effective by virtue of low initial cost per copy and low cost of operation and maintenance over a relatively long period. The low cost of initial ownership stems from the relatively simple transmitters, transceivers, receiver/decoders and mobile transporters, and the minimal computation/encoding interface equipment required. The low cost of O/M derives from the high state of development and ruggedization of equipment in this general frequency band, Another factor is that equipments already in inventory, may be available and could be modified/retrofitted at relatively low cost.
- Is capable of supplying effective direct hit and proximate hit audio cueing employing MILES or IDFSS transducers.
- Requires relatively low average transmission power and efficiency is such that prime power fuel requirement should be low. Solar power may be employed, thus greatly reducing fuel requirement.
- Accomplishes, essentially an "instrumented range" without the need for permanent instrumentation. That is, by simply emplacing the truck mounted master transmitter with a computation/interface hut and two smaller transceiver stations, the whole range is instrumented and operable. Following the simulation exercise, the three units can be moved out to "instrument" another range.

Thus the trilateration system appears to have significant advantages as an all weather, non-battle interfering, ground designation system for I/AFWES.

Along with the advantages, it appears also to have the following disadvantages.

- It is not presently apparent how it can accomplish effective **visual** proximate and remote cueing.
- Elevated antennas will probably be required, in most simulated battlefield ranges. If beam directionality is employed to contain most of the energy in the range and achieve gain to minimize transmitter power, apertures may be fairly large.

- The frequency range at which operation is desired (low or mid VHF) may pose frequency allocation problems (possible interference with certain other military and with commercial systems).
- It requires separate (RF) designation receivers.
- In order to achieve high designation range (time coincidence) accuracy, relatively large bandwidth and/or designation receiver signal to noise ratio will probably be required. Major design trades exist between transmission bandwidth, receiver processing, receiver type, required transmission power, transmission format and required designation accuracy.

C. PRELIMINARY DESIGN

1. Basic Design Factors

While detailed design of an RF Trilateration Ground Designation System is beyond the scope of this effort, certain basic design factors must be examined to establish overall feasibility. These include:

- propagation time and transmission time relationships;
- designation accuracy and bandwidth;
- clock rate;
- delay implementation;
- modulation format;
- designation receiver type;
- approximate design and size/weight;
- transmitter power requirement and receiver sensitivity; and
- carrier wavelength.

2. Propagation/Transmission Times

Figure D-6 depicts master (M) and slave (S) stations deployed for designation at a 15 x 30 km simulated battle area.

Range R_{ms} is approximately 35 km. Propagation time from M to either S is $\frac{35 \text{ km}}{0.3 \text{ km}/\mu\text{sec}} = 116 \text{ } \mu\text{sec}$. For a designation point,

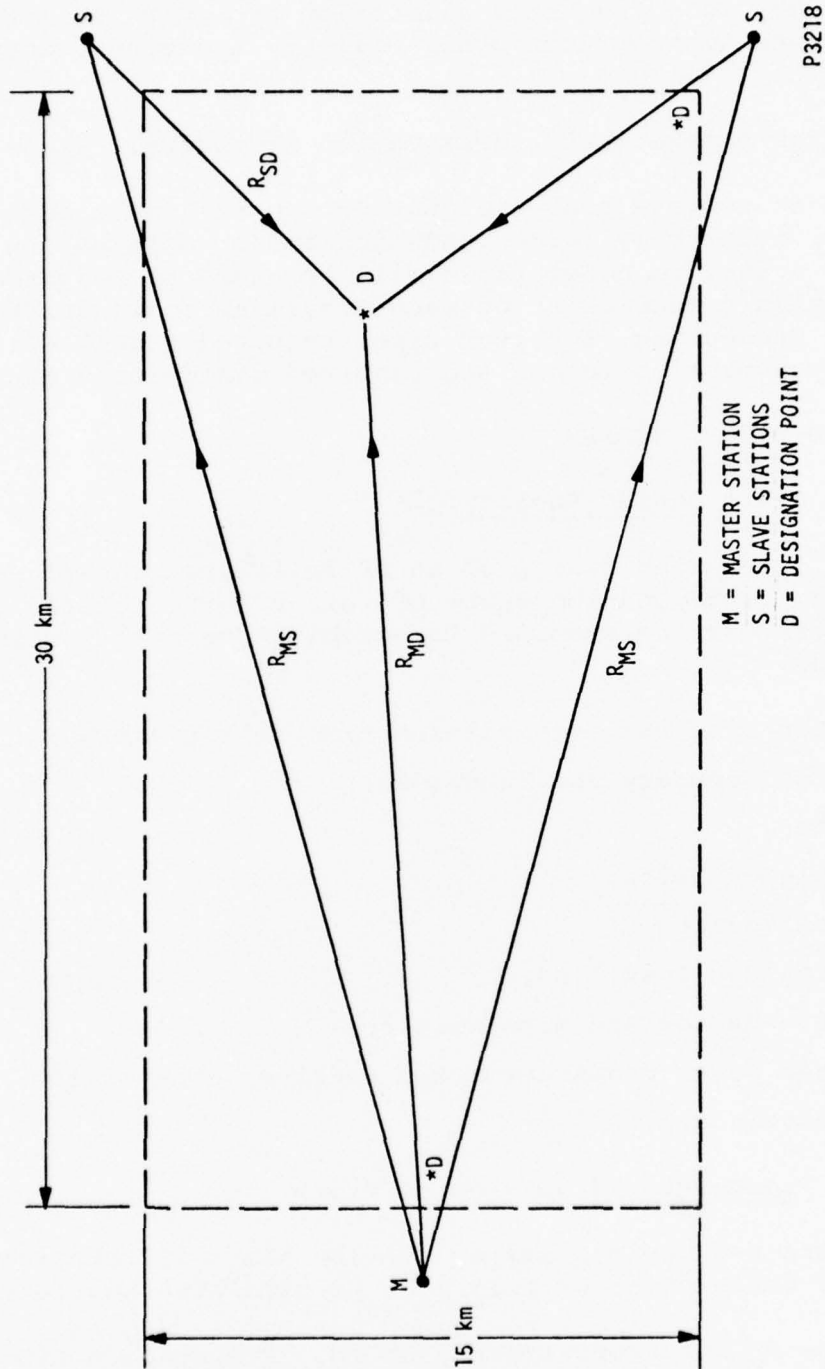

Figure D-6. Trilateration Propagation

D, at the edge of the range near M the total propagation time from M to S to D will be about twice 116 μ secs or about 230 μ secs. For this case, however, propagation time from M to D will be very short, (in the order of 7 μ sec), if M is located about 2 km from D. For a D very close to a corner of the range near an S, the propagation time from that S to D will be very short, again about 7 μ secs if the S to D distance is about 2 km. All other total path and single path propagation times will fall between these extreme values.

Since maximum time for a designation is about 230 μ secs plus two much smaller fixed delays, it is obvious that successive designations can occur very quickly. The minimum (7 μ sec) propagation times which occurs for extremely short ranges of S to D or M to D should cause no problem if address transmission lengths (times) are small. Short address times are also needed to keep the fixed delay times as short as possible as will be shown subsequently. Note that propagation time from master to slave stations (which must be addressed) is always relatively long. It is probable that transmissions from slaves and master to designation points (receivers) need not employ an address, this will also be discussed subsequently.

3. Designation Accuracy/Bandwidth Considerations

It is desirable to have designation location accuracy of about 30 meters radius for relatively small kill radius indirect weapons. This requires time coincidence of

$$\frac{3.0 \times 10 \text{ m}}{C} = \frac{3 \times 10 \text{ m}}{3 \times 10^8 \text{ m/sec}} = 1 \times 10^{-7} = 0.1 \mu\text{sec}$$

This is true whether it be one pulse in an address, a following range/timing pulse or a single pulse used for the time coincidence in case an address is not employed. This order of pulse time of arrival determination accuracy could require relatively wide signal bandwidth. It is desirable to hold down transmission bandwidth in order to minimize bandwidth percentage of carrier frequency and the frequency allocation band requirement. Thus it is desirable to accomplish as much "pulse splitting" or increase in time measurement accuracy in the receiver as possible. Thirty meter accuracy requires a bandwidth of 10 MHz. If a relatively low VHF carrier of 45 MHz is employed, and the accuracy is achieved completely with transmission bandwidth, that is, pulsewidth, the

required percentage bandwidth is $\frac{10}{45} = 22.2\%$

This is too high. If on the other hand, a carrier as high as 170 MHz is employed, percentage bandwidth is $\frac{10}{170} = 5.88\%$.

This is still relatively high. Also, from the standpoints of receiver noise and frequency allocation it is desirable to hold RF bandwidth to considerably below this. RF bandwidth of 1 to 2 MHz (preferably 1 MHz) is desirable. This means that effective pulse splitting of about ten times must be accomplished in the receiver. This can be done by processing, if the signal-to-noise ratio is high enough.

Figure D-7 shows the typical amount of "pulse splitting" or range measurement accuracy improvement over RF pulsewidth, that can be expected, as function of signal-to-noise ratio. In this plot, τ is the actual pulsewidth. As shown, to achieve an effective improvement (ΔR) of 1/10 the actual pulsewidth, a S/N of about 14 db is required. If an improvement of ten times can be achieved on a single pulse basis, the 1 MHz RF bandwidth can be realized and the 30 meter designation accuracy can still be achieved.

The receiver processing techniques employed would typically be early gate - late gate or leading edge differentiation or perhaps double differentiation. This of course adds moderately to designation receiver complexity and cost. If a 1 KHz transmission bandwidth is employed (the bandwidth necessary for a 1 μ sec pulse to rise), a superheterodyne receiver will require 2 MHz BW to receive all of the pulse power, because of the double side band nature of the IF amplifier.

If a crystal video receiver is employed, the inherently wide bandwidth is available but the minimum sensitivity is significantly less than typical narrow band superheterodyne receivers. Also, crystal video receivers tend to have inferior fidelity, even with their wide bandwidth, because of the square law (rather than linear) nature of the detection, which limits dynamic range. Again, noting the double sideband nature of the superheterodyne IF signal, the superheterodyne requires twice the bandwidth of the crystal video receiver for a given frequency response. For low gain, high gain-bandwidth product can be obtained with the crystal video receiver. However, it is difficult to achieve a wide dynamic range, high gain video amplifier.

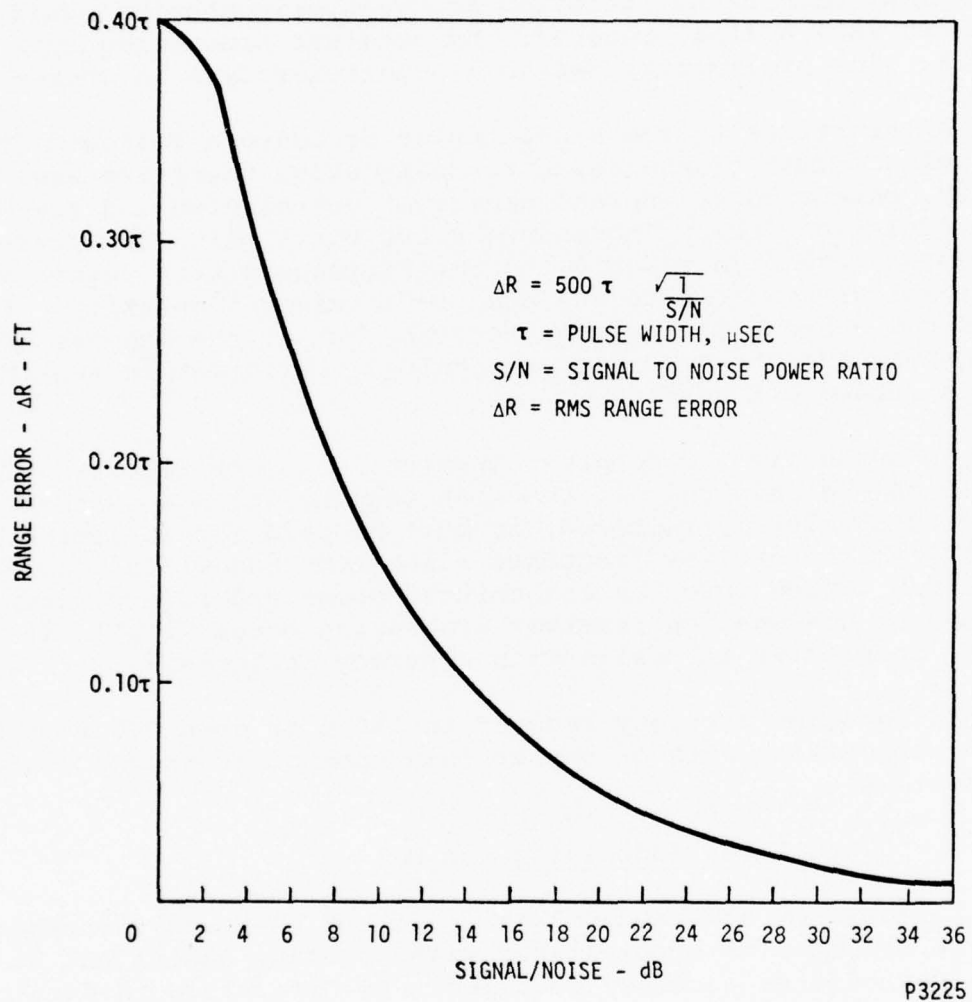

Figure D-7. Signal-to-Noise Ratio Versus Range Error (Pulse Splitting)

While crystal video designation receivers may be desirable from a cost standpoint, it is questionable whether they would be sufficient because of certain shortcomings, particularly dynamic range, and they do not solve the bandwidth/noise problem. Trade-offs do exist and further detailed study/experimentation would be required to make a final receiver and receiver processing type selection. For preliminary design a superheterodyne is chosen.

Alternatives to the single pulse or address followed by single pulse format transmission to designation receivers are primarily, psuedo noise (spread spectrum) correlation and frequency modulation (FM). The psuedo noise correlation can yield high accuracy and high immunity to interference but it requires wide transmission bandwidth and adds to receiver complexity. FM can probably achieve the desired accuracy but at the expense of high required S/N and receiver processing. FM format is treated more in a subsequent section.

To summarize the complex bandwidth/accuracy/required S/N trade, it may be said that if the high ranging (time coincidence) accuracy is absolutely required, it must be paid for in transmission bandwidth (which involves frequency allocation bandwidth), and/or receiver S/N (which involves transmitted power and receiver bandwidth, and/or designation receiver processing complexity). It may be that a compromise in designation accuracy is logical.

Designation accuracy reduced to 150 m or even 300 m would still be competitive with or better than some other ground designation systems.

4. Clock Rate, Addressing and Delays

Reinsertion of fixed delays $\Delta 1-2f$ and $\Delta 2-Mf$ as discussed in section B-1 must be accomplished with accuracy equivalent to the time coincidence accuracy required. As determined in section C-3, for 30 m designation accuracy, time coincidence must occur within 100 nsec. This means that the master transmitter must transmit to slaves and designation point with timing between transmissions, that is, fixed and variable delay, controlled to 100 nsec. Also reinsertion of these delays in the designation receivers must be accomplished to within 100 nsec.

This is best accomplished with a clocked sequential digital circuit (shift register) acting as a delay line. A 10 MHz clock (pulse) rate would be required for 30 m accuracy. The number of

shift register stages required is related to clock period and desired delay by

$$\Delta = n-1 (T), \text{ where } \Delta \text{ is desired delay}$$

$$T \text{ is clock period}$$

$$n \text{ is number of stages.}$$

It is desirable to hold down total fixed delay required, in order to minimize cost and size of designation receivers. On the other hand, it is desirable to hold transmission bandwidth to the order of 1 MHz as discussed previously. This means that transmitted pulses would be 1 μ sec long.

Minimum slave station address times will be somewhat dependent on minimum pulse length. Addresses must be kept as short as possible, since they will dictate the shortest allowable fixed delay Δ_{1-2} . A 2 pulse code may be employed for slave station addresses. One slave can be set to respond to 2 pulses separated by 4 μ secs and the other to pulses separated by 3 μ secs. When a desired designation point in the same distance from each slave station the second address may consist of the second pulse of the first address and a second pulse following at the proper time interval shown as follows:

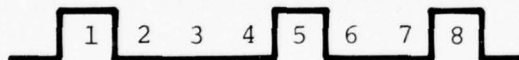

This is the case which dictates the minimum fixed delay Δ_{1-2} which must be reinserted at the designation receiver.

Although the transmitter and its control computation/logic cannot change the address of the slave stations, it has the choice, for the above case (that is, equal propagation paths) of transmitting either address first. If the longer (5 μ sec) is transmitted first and the shorter (3 μ sec) is transmitted second, then the minimum allowable delay, Δ_{1-2} , is 3 μ sec.

The delay Δ_{2-M} is not critical because the master transmitter can take into account the address time of the second slave addressed in determining the exact time of its direct transmission to the designation point. In the interests of keeping fixed delay times down, to minimize designation receiver delay register length, a delay of 2 μ secs is chosen. This means that total reinsertion delay length must be 5 μ secs. The total number of stages (flip-flops) required is,

$$n = \frac{\Delta}{T} + 1 = \frac{5 \times 10^{-6} \text{ secs}}{1 \times 10^{-7} \text{ secs}} + 1 = 51$$

This can be achieved by employing seven miniature, 8 stage TTL solid state shift registers in series. The shift register and coincidence gate configuration is shown in Figure D-8.

5. Modulation Format

Discussion thus far has centered primarily around transmission of pulsed addresses from master to slave stations and pulsed addresses or a single time coincidence pulse from slaves and master to designation receivers. There is no good reason, however, why FM may not be employed, particularly for the transmissions from slaves and master to designation points.

In this case a burst of VHF carrier wave would be transmitted from each of the three stations at the proper time (controlled by the master station) and the frequency would be shifted within 1 μ sec at exactly the right time to cause time coincidence at the right location. This would be analogous to transmission of single shot 1 μ sec pulse. The transmission bandwidth employed at the time of shift would determine the sharpness with which the shift would take place. Again, a 1 MHz bandwidth would yield a 1 μ sec time to complete frequency shift. A sharp (100 nsec) pulse would be produced in the receiver near the middle or the end of the frequency shift time, thus effectively achieving the 30 meter time coincidence accuracy.

Frequency shift may also be employed for the slave station addresses. This would be accomplished by producing a brief series of "zeros and ones" as is done in various FM digital communication systems - the so called frequency shift keying (FSK). That is -- transmitted frequency above carrier (center) frequency represents a one and below carrier represents a zero.

It should be noted here that the same time accuracy must be maintained in triggering the slave stations as in reception at the designation receivers or designation location accuracy will be lost. Therefore, the same type of "frequency shift time splitting" or pulse splitting, as the case may be, must be accomplished at slave stations by receiver processing, if transmission bandwidth is to be held down to about 1 MHz.

6. Receivers

Several factors affecting the types of receiver chosen, such as, functional requirements and basic design have been discussed in foregoing sections. Detailed design studies and breadboarding

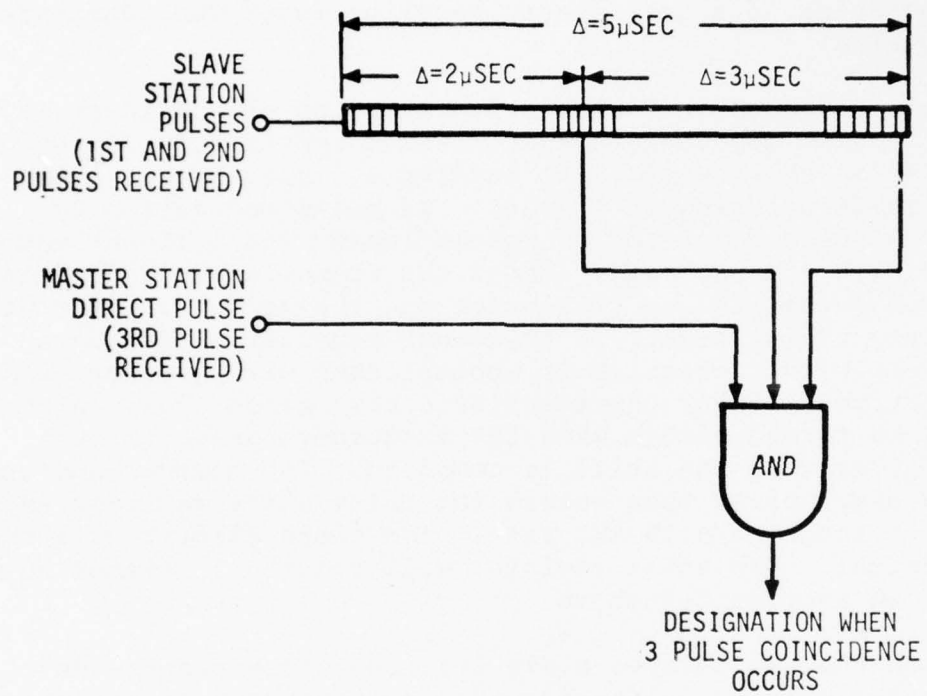

P3226

Figure D-8. Delay Shift Register/Coincidence Gate Configuration

would be required to arrive at an optimum designation receiver design, that would take into account overall system design factors (modulation format, transmission bandwidth, required/desired accuracy, transmitter power and the like), and receiver peculiar factors such as weight, volume, sensitivity and power requirement. However, the general configuration and preliminary feasibility design of the overall system, as discussed in foregoing sections, allows generation of a preliminary baseline functional designation receiver design.

This is shown in Figure D-9. It is an all solid-state, single conversion superheterodyne (minimum sensitivity 90-100 dbm). IF bandwidth is about 2 MHz, (to receive a 1 μ sec pulse, or a frequency shift occurring in 1 μ sec). If pulse modulation is employed the pulse detection is accomplished with a linear envelope detector. With a 1 μ sec pulse and 1 MHz transmission bandwidth, the received pulse will be triangular and the pulse splitter will differentiate at the peak. If frequency modulation (frequency shift) is employed, detection is accomplished with a discriminator having relatively linear characteristic near cross-over. A sharp pulse will be formed either when the frequency passes through carrier (f_0) or when the shift is complete. The narrow (approximately 100 μ sec) pulse then enters the delay shift register and is clocked through at a 10 MHz rate. The clock circuit will employ crystal control. The shift register will require 51 stages as calculated in section C-4 above.

When the two delayed slave station pulses and the undelayed master station pulses appear simultaneously at the coincidence gate input, it will output an audio cue signal and remove an inhibit to a storage (memory) register thus allowing the weapon type digital message from the master station to enter the memory. The weapon type message is transmitted following transmission of the final designation pulse from the master station. Thus, weapon type information cannot be decoded, lethality determined and kill designated unless time coincidence of the three designation pulses occurs. The weapon type word length, if a binary number is employed, will be 6-bits long, if up to 33 different weapon types must be identified.

Various miniature solid state paging receivers presently marketed have much of the capability required of the postulated baseline designation receivers. They operate at the same general carrier frequencies of interest, employ low noise superheterodyne

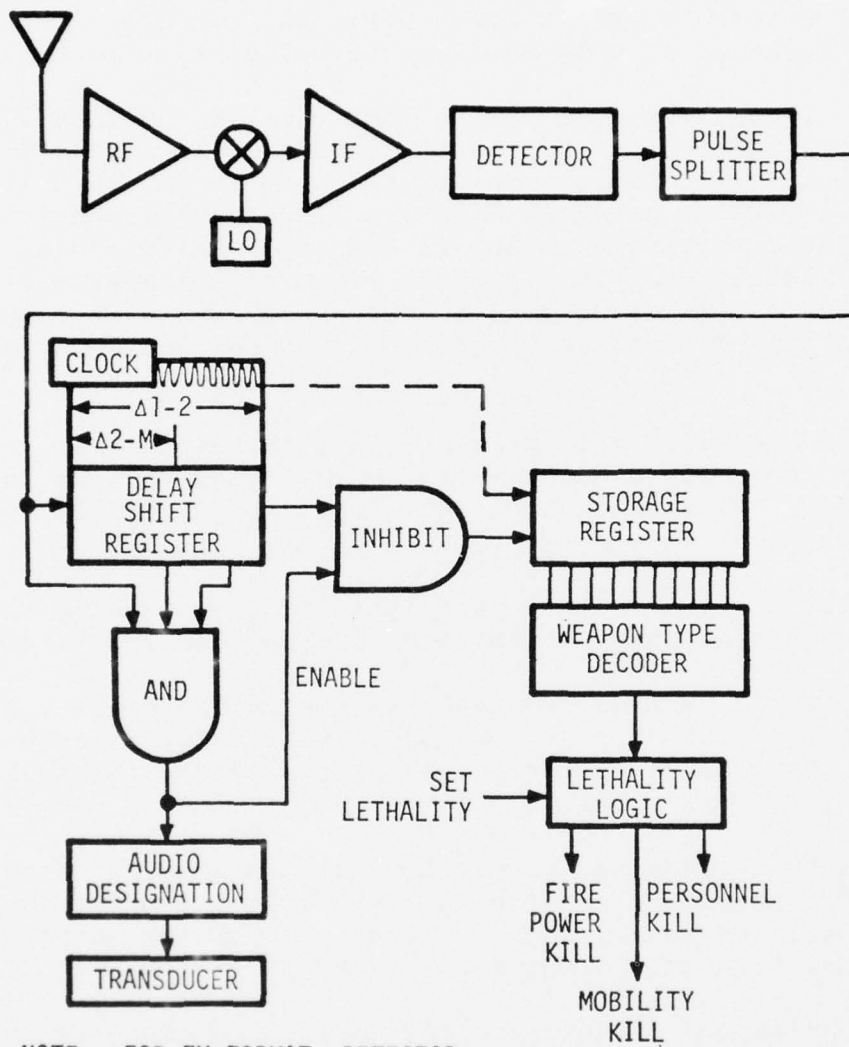

P3227

Figure D-9. Designation Receiver Functional Diagram

receive systems and digital discrete addressing. In addition they have very low prime power drain and can operate for significant lengths of time on small, internal expendable batteries.

Typical of such paging receivers is the Code 2, designed, produced and marketed by the Martin Marietta Corp., Orlando Div. A schematic of this basic pager is shown in Figure D-10, descriptive material is given in Figure D-11 and specifications in Table D-1. These receivers employ FM frequency shift keying to produce digital addresses. 16-bit words yield approximately 64,000 discrete addresses. With minor modifications they could be adapted to the designation receiver requirement. The modifications, essentially are:

- Widen bandwidth from present approximately 14 KHz to 2 MHz. This is easily done primarily by changing filters in IF stages. MM already has a new design pager receiver with 1 MHz bandwidth.
- Reduce required word length decoding from 16-bits to 6-bits (weapon type information) and eliminate address decoding logic.
- If desired carrier frequency is not in the present pager high (148-160 MHz) or low (35-44 MHz) band, at around 100 MHz, change operating center frequency by changing small RF coil and L.O.
- Replace present pager very low gain internal antenna with much higher gain external helmet mounted antenna such as illustrated in Figure D-12, thus greatly increasing low signal strength performance (range).
- Add pulse (or frequency shift) splitting circuits following video detector (or discriminator).
- Increase clock frequency to 10 MHz.
- Add delay shift register, coincidence gate, weapon type decoder and lethality logic circuits.
- Eliminate beeper

| REV | DATE | DESCRIPTION |
|-----|----------|-------------|
| 1 | 10/11/71 | REVISED |
| 2 | 11/11/71 | REVISED |
| 3 | 12/11/71 | REVISED |

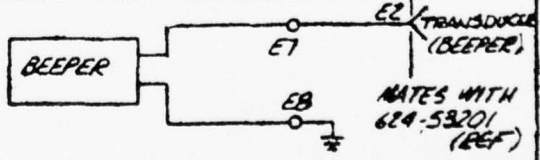
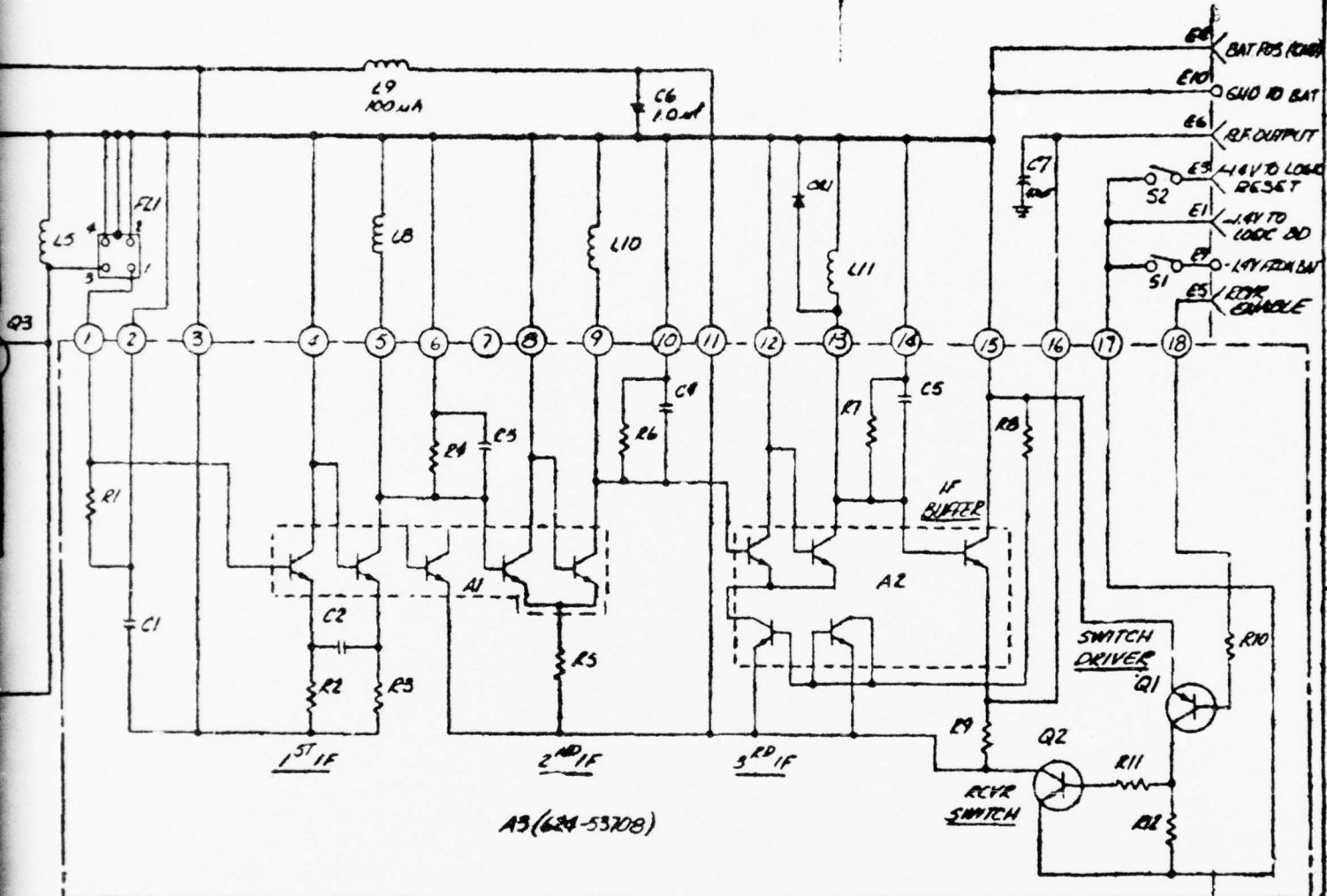

| QUANTITY / QTY | DESCRIPTION | UNIT | PRICE | TOTAL | REVISION | DATE | BY | APPROVED |
|----------------|------------------|------|-------|-------|----------|------|----|----------|
| 1 | RF PC BOARD ASSY | | | | | | | |

| | | |
|--|--|---|
| USE FOR SPECIFICATIONS CHECKS DIMENSIONS ARE IN INCHES AND ARE AFTER PLATING | CONTACT NO. ORDER BY CHECKED DATE 11/11/71 | RAYTHE BARRITT CORPORATION SCHEMATIC DIAGRAM, RF PC BOARD ASSY |
| PART LIST QTY PART NO. DESCRIPTION | OR BY DATE 11/11/71 | SIZE CODE IDENT NO. D 04939 624-53200 |

2

operation

Code 2 receives all signals transmitted into the paging area and searches for a special code to match its own address. When that code is found, the receiver produces a distinctive tone that tells the user he has been paged.

components

Code 2 contains a single AA battery, built-in antenna, and three solid-state plug-in modules: one for RF functions, one for logic, and one for receiver address.

An input crystal filter in the RF module provides high image rejection and protection from off-channel signals. Ceramic filters give additional selectivity and improved signal-to-noise ratio.

The logic module detects the proper address, using error detection and sync operation to evaluate RF energy and select the best transmissions. These operations, which guarantee rejection of unsatisfactory signals, are accomplished by a Bose-Chaudhuri error-detecting

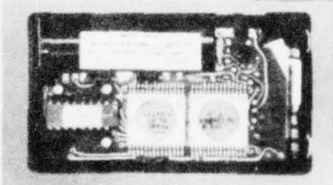

decoder that also controls receiver RF operation and extends battery life.

A receiver's address is set into the all-electronic address module, which easily plugs into the logic section. Address modules are interchangeable between receivers, giving complete address versatility.

CODE in a class by itself

single or dual address

A Code 2 receiver may be equipped with single or dual address module. Dual address enables the user to be paged by two different parties, or it can alert the user to either of two predetermined messages. In some applications, one address is "private," while the other is shared by a number of receivers (for alerting staff members, off-duty officers, firemen, etc.).

automatic or manual reset

In the automatic "Time-Out" model, the paging tone stops after several seconds, or may be stopped sooner by touching the receiver faceplate. Code 2 receivers are also available with the "No Time-Out" or manual-only reset feature, where the tone continues to sound until the faceplate is touched, assuring that the user never misses a call.

choice of frequency

Code 2 receivers are equipped either for low band or high band paging operation. Additional frequencies are available for export models.

alert tone

A 2100-Hertz signal is used as the alerting tone. When the receiver is initially turned on, the tone sounds indicating a satisfactory battery voltage level.

warranty and maintenance

Martin Marietta Corporation guarantees each Code 2 receiver for 1 year from time of shipment. Free factory maintenance is included in the receiver warranty for the first year; subsequent maintenance is performed on a per-unit basis or under a flat-rate maintenance contract.

Figure D-11. Code 2 Pager Descriptive

CODE 2

puts it all together

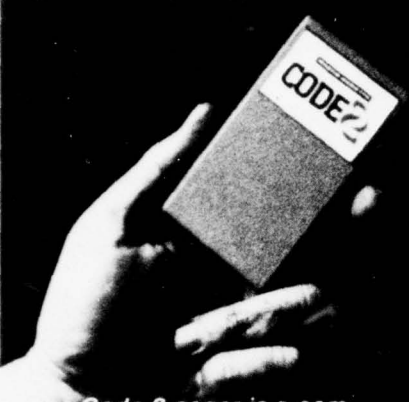

The Code 2 pager is a completely self-contained radio receiver that sounds an alerting tone when its address is dialed from a standard telephone. Code 2 receives paging signals in buildings, elevators, automobiles — anywhere the user might be. Range depends on the number and power of radio transmitters in the paging system.

Small, lightweight, and rugged, Code 2 is built to last — can be easily carried in coat pocket, purse or belt. Its clip makes it a snap to attach Code 2 to a car sun visor or other convenient location.

Long-lasting, economical operation results from a single AA battery that powers the receiver for months.

A product of space-age digital design, Code 2 is exceptionally dependable — a false call might be expected once in a lifetime! This makes Code 2 the world's most dependable digital pager.

Putting it all together, these features make Code 2 the most desired personal pager.

- Weight, 4.5 ounces
- Convenient size and shape
- Virtually no false calls
- Latest solid state design for high reliability
- Single or dual address
- Manual or automatic alert tone reset
- Interchangeable addresses.

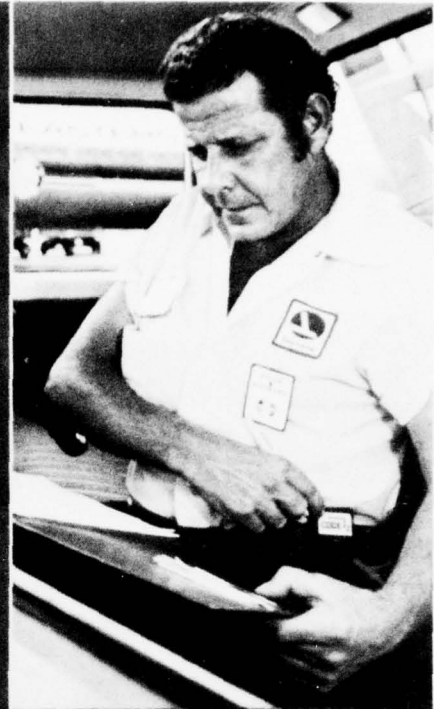

Code 2 is the pager you can depend on — it's truly in a class by itself!



Figure D-11. Code 2 Pager Descriptive (Cont'd)

mechanical characteristics

High impact plastic case
 Tamperproof design
 Plug-in address module
 Reset faceplate
 Hermetically sealed logic
 Weight, 4.5 oz (with mercury battery)
 Size, 2.0 x 3.5 x 0.875 inches

standard equipment

High or low band
 Mercury battery
 Three case-locking keys
 Dual address module (PR-101 & PR-201)
 Single address module (PR-102 & PR-202)
 Case color: Black
 Clip/without clip

options available

Single address module (PR-101 & PR-201)
 Custom reset faceplate
 Colored case
 Property stamp on case
 Leather carrying case

| Specifications | Receiver Model | | | |
|---|----------------|--------|---------|--------|
| | PR-101 | PR-102 | PR-201 | PR-202 |
| High Band 148 to 166 MHz* | X | X | | |
| Low Band 35 to 44 MHz* | | | X | X |
| Sound Pressure Level 80 dB at 12 inches | X | X | X | X |
| Sensitivity for 99% Call Completion 6.7 μ V/m to 160 MHz 8.5 μ V/m above 160 MHz 5.4 μ V/m | X X | X X | X | X |
| Capture Ratio 2 dB | X | X | X | X |
| Intermodulation 60 dB | X | X | X | X |
| Spurious and Image Rejection 55 dB to 160 MHz 40 dB above 160 MHz | X X | X X | X | X |
| Adjacent Channel Rejection 50 dB | X | X | X | X |
| Temperature Range 0 to 60° C (operating) -40 to 80° C (storage without battery) | X X | X X | X X | X X |
| Number of Addresses Single Dual | X† X | X | X† X | X |
| Alert Tone Automatic Time-Out after 6.7 Seconds Continuous, with Manual Reset | X | X | X | X |

*U.S. frequencies; export models available from factory on special request.
 †Optional

Specifications subject to change without notice.

Table D-1. Code 2 Pager Specifications

All of the above changes will have little effect on size, weight and power consumption since they can be implemented with solid state LSI components and some of the present pager circuitry is eliminated. (Weight and volume are given in Table D-1.) A single AA 1.5v battery, internal to the case, powers the unit for 1000 hrs. with battery saving feature, or 350 hrs. without. Present cost of the pager is approximately \$225. in large quantities. It is estimated that cost of these units as modified/redesigned for designation receivers would be between \$300 and \$350 in large quantities.

Little need be said about slave station receivers, except to reiterate that they will be required to receive and decode short pulsed or PSK digital addresses, their clock rate for measurement of received timing pulse must also be high (10 MHz) and they must be capable of pulse (or frequency shift) splitting, if designation point accuracy is to be maintained. They will not require delay or delay reinsertion capability since this is accomplished at the master station and designation receivers.

7. Transmitters

In order to determine required transmitter power it is necessary to establish required power density at the receive antennas, the maximum range of receivers, and the maximum battle area to be covered. Desired carrier frequency, weather capability, topography, and allowable transmitter size (primarily antenna) are important factors.

In order to establish required power density at designation receivers it is necessary to take into account certain designation receiver performance factors:

- Effective area of receiving antennas (see Figure D-12) is about $20 \times 5 \text{ cm} = 100 \text{ cm}^2$.
- Receiver minimum sensitivity ($P_R \text{ min}$) is -90 dbmw.
- Receiver RF losses are 3.0 db.
- Receivers will require a S/N of 14 db in order to achieve the necessary 10 times pulse (or frequency shift) splitting necessary for 30 m accuracy.

$$14 \text{ db} = \text{antilog } 1.4 = 25.$$

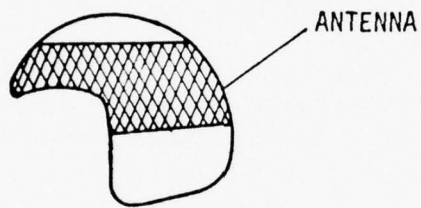

P3243

Figure D-12. Designation Receiver Helmet Mounted Antenna

Then minimum peak power density should be,

$$\hat{P}_d = \frac{(2.0) 25 (10^{-9} \text{ m watt})}{100 \text{ cm}^2} = \frac{(10^{-9}) (10^{-3}) (50) \text{ watts}}{100 \text{ cm}^2}$$

$$50 \times 10^{-14} \text{ w/cm}^2 = 50 \times 10^{-10} \text{ w/m}^2$$

Having determined required power density at designation receivers, certain factors and overall requirements of the master (and slave) transmitters must be considered as follows:

- A transmitter must cover a complete battle area of 15 x 30 km. It is desirable to avoid transmitting energy into areas outside the range, to the extent possible.
- All areas of the 15 x 30 km range must be covered regardless of topography (variations in elevation).
- Weather conditions will range from standard atmosphere to heavy rainfall.

Since the azimuth beamwidth from a less than isotropic antenna has a finite width, the transmitting antenna should be some distance from the end of a rectangular area to be covered (illuminated), as shown in Figure D-13.

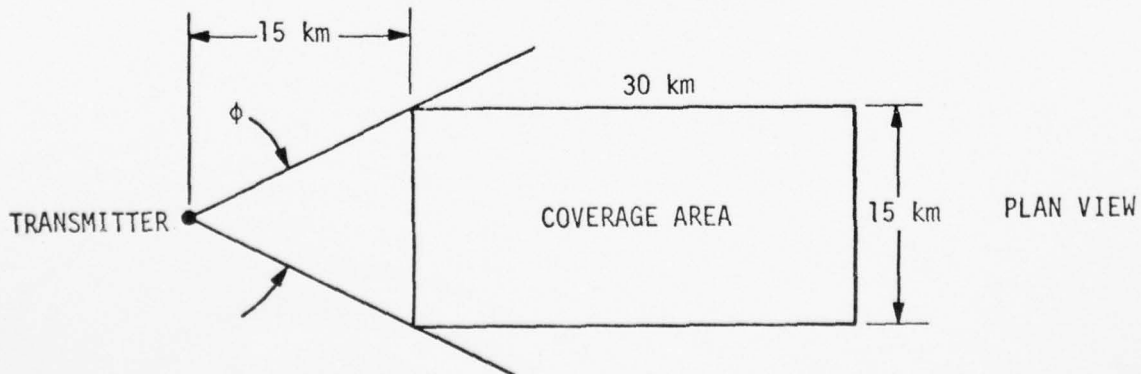

P3244

Figure D-13. Maximum Range Size Coverage Area (Azimuth)

The 3 db beamwidth angular coverage of the xmtr antenna (as shown in Figure D-13) is $\tan [7.5 \text{ km}/15 \text{ km}]^2 = [\tan 0.5]^2 = 26.56$
 $2 = 53.13$ degrees. This azimuth beamwidth and transmitter setback (15 km) from the edge of the battle simulation area is a reasonable trade-off. Furthermore, assume an elevation variation of 2 km, (± 1 km), or 6560 ft. in the middle of the long dimension of the battle area, as shown in Figure D-14.

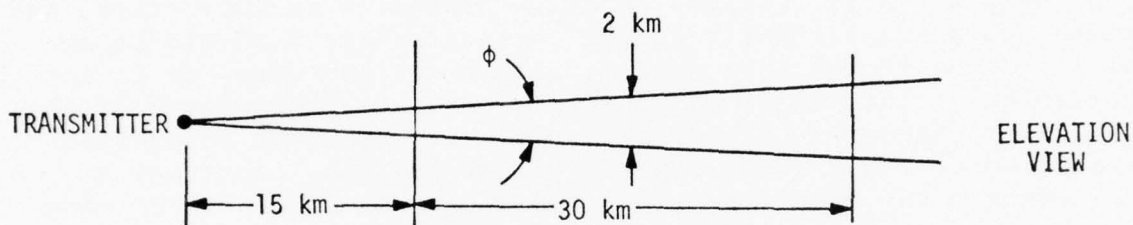

P3245

Figure D-14. Maximum Range Size Coverage (Elevation)

This is probably an extreme case for most battle simulation areas in the free world. However, the elevation beamwidth required is still much less than that required in azimuth. Since it is desirable to employ a relatively long wavelength transmission, the relatively narrow elevation beam, ϕ , as determined below, would require a very large vertical aperture dimension.

$$3\text{db } \phi = 2 \tan \left(\frac{1 \text{ km}}{15+15 \text{ km}} \right) = 2 \tan \frac{1}{30} = 1.9 \text{ degrees } (2) = 3.8 \text{ degrees}$$

The 3 db width of a collimated beam produced from an aperture is approximately $1.2 \frac{\lambda}{d}$ radians, where λ is the wavelength of the electromagnetic energy and d is aperture dimension in the plane of interest. Thus, d must equal approximately $\frac{1.2 \lambda}{\text{Bm. Wdth}}$

As determined previously, the elevation beamwidth (ϕ) should be 3.8 degrees = .066 radians, and the azimuth beamwidth (ϕ) should be 53.13 degrees = .927 radians. If a frequency of 100 MHz is

employed ($\lambda=3m$), the required horizontal aperture dimension is,

$$d = \frac{1.2(3)}{.066} = 3.88m = 12.73 \text{ ft}$$

The required vertical aperture dimension is,

$$d = \frac{1.2(3)}{.066} = 54.55m = 178.9 \text{ ft}$$

Obviously a 178 ft vertical aperture dimension is impractical and therefore a significantly larger vertical angle ϕ should be employed, even though more energy will be spilled over, as in the horizontal plane, where considerable energy falls outside of the assumed rectangular battlefield area. It should be recognized that line-of-sight (LOS) considerations are less important at the assumed VHF band frequency (100 MHz) than would be the case at much higher microwave frequencies (L,S,C,X or K bands), and considerable space portion of the ground wave will exist, if the antenna is elevated a few wavelengths.

Since it is desirable to constrain as much of the energy to the range as is practical, particularly in azimuth, a square aperture is postulated which would produce approximately 55 degree azimuth and elevation beamwidths. This would achieve the desired azimuth coverage (with the 15 mk set back), and though the elevation beamwidth is considerably wider than needed for coverage, the antenna vertical dimension would be no greater than the horizontal.

This aperture would be 150 ft in area (12.25 x 12.25 ft), would be 50% efficient and have a gain of 10db. It would not necessarily be solid or heavy. It will be recognized that various types of antennas might be employed at this wavelength to achieve moderate directivity and gain. These include the types often employed for commercial TV such as end-fire arrays of dipoles or folded dipoles (yagis), so-called super fans, lazy Xs, and the like. Detailed antenna design is beyond the scope of this study. It may be desirable to have 2 or more different antennas with different directionality characteristics and size/shape to be employed for different size/shape simulated battlefield ranges. Suffice it to say that for the order of directionality discussed above, at least one dimension of the antenna will be ten or more feet long. It will be shown that the antenna gain is not really needed so far as transmitter power is concerned. The primary

reason for directionality is to constrain the energy mostly to the range. In fact, if an isotropic or semi-isotropic antenna were employed the stations could be placed just at the edge of the battle range and the maximum range to designation receivers would be less, thus cancelling part of any need for transmitter power or antenna gain. At any rate, 10 db antenna gain (55.3 degree beamwidths) will be employed in the following calculations of required transmitter power.

At the 3 m wavelength, atmosphere attenuation, including heavy rainfall, will be negligible. An approximately 3 db RF loss will occur between the actual transmitter (tube) and the antenna.

Required transmitter peak power may now be determined using the relationship.

$$\hat{P}_{D \text{ req}} = \frac{\hat{P}_t G_t}{4\pi R^2 L_t} \text{ watts/m}^2$$

where \hat{P}_D = peak power density required at the designation receiver antenna = 50×10^{-10} watt/m²

P_t = required peak transmitter power

G_t = transmitting antenna gain = 10 db

L_t = transmitter RF loss = 3 db

R = maximum range from a transmitter (master or slave) to a designation receiver

Again, assuming the 15 km setback from the near end of the range, R is

$$\sqrt{(45\text{km})^2 + (7.5\text{km})^2} = \sqrt{2081.25} = 45.6 \text{ km}$$

$$= 45,600 \text{ m}$$

AD-A034 453

INTERNATIONAL LASER SYSTEMS INC ORLANDO FLA
INDIRECT/AREA FIRE WEAPONS EFFECT SIMULATOR STUDY. VOLUME II. P--ETC(U)
JAN 77 R E ODOM

F/G 19/5

N61339-76-C-0070

UNCLASSIFIED

TND-TR-76-0002-VOL-2

NL

3 of 4
ADA034453



and $R^2 = 4.56 \times 10^4 \text{ }^2 = 20.79 \times 10^8 \text{ m}^2$

$$\hat{P}_t = \frac{\hat{P}_{D_{req}} 4 \pi R^2 L_t}{G_t} \text{ watts}$$

$$= \frac{(5.0 \times 10^{-9})(12.57)(2.079 \times 10^9)(2)}{10} = 26.133 \text{ watts}$$

a 10 db field degradation factor should be added to this, yielding 261.33 watts. For a duty cycle (on time/off time) as high as .01, average power (\bar{P}_t) is only 2.6133 watts. If an isotropic antenna is employed, that is, no attempt is made to constrain much of the energy to the range area, required \bar{P}_t will be 2,613.3 watts and P_t will be 26.133 watts. Assuming the same antennas are employed for slave stations as master station and setbacks are the same, slave station transmitted power requirement will be the same as for the master. A functional diagram of the master transmitter was shown in Figure D-3 to facilitate understanding of the basic tri-lateration system configuration and operation. This diagram is considered applicable for preliminary design and will not be repeated here.

The prime power requirements to operate the transmitter(s) for the conditions/situations considered above, including the 10 db field degrada-factor, and assuming only 50% transmitter efficiency are:

for 10 db gain antenna and .01 duty cycle,

$$\frac{2.6133 \text{ watts}}{0.5} = 5.226 \text{ watts}$$

for 0 db gain (isotropic antenna) and .01 duty cycle,

$$\frac{26.133}{0.5} = 52.26 \text{ watts}$$

This is within the capability of solar cell power, on a 24 hr. basis, in many parts of the world. Where solar energy cannot suffice, the fuel required for prime power generators is obviously minimal.

TRILATERATION GROUND DESIGNATION SYSTEM
GENERATION BREAKDOWN

Designation Receiver Systems:

| <u>Item</u> | <u>No. Req'd</u> |
|---|------------------|
| Antenna (helmet cover mounted) | 1 |
| Case (with attachment) | 1 |
| Battery (internal or external to case, non-rechargeable) | 1 |
| RF amplifier circuit | 2 |
| RF mixer circuit | 1 |
| RF local oscillator circuit | 1 |
| IF amplifier circuit | 3 |
| Differentiator (or discriminator) | 1 |
| Digital clock circuit (10 MHz) | 1 |
| Delay shift register (51 stage) | 1 |
| Coincidence gate circuit (3 inputs) | 1 |
| Inhibit/enable circuit | 1 |
| Storage register 8-bit | 1 |
| Digital decoder circuit (33 codes) | 1 |
| Lethality logic circuit (with set control) | 1 |
| Kill indicator | 1 |
| Audio designation circuit (transducer driver) | 1 |
| Audio transducer | 1 |
| Internal wiring | |
| External wiring | |
| Switch (on-off) | 1 |

TRILATERATION GROUND DESIGNATION SYSTEM

GENERATION BREAKDOWN (Con't)

Master Transmitter (1 req'd):

| <u>Item</u> | <u>No. Req'd</u> |
|--|------------------|
| Antenna (dipole or folded dipole or array if dipoles/folded disoles or "bedspring" type) | 1 |
| RF power amplifier | 1 |
| Modulator (pulse or FM) | 1 |
| RF source (approx. 100 MHz) | 1 |
| Driver | 1 |
| Slave station address encoder | 2 |
| Slave station address encoder switch | 1 |
| Weapon type encoder | 1 |
| Mini-computer (digital-to accomplish logic and tuning, coordinate conversation, timing control and slave station switch control) | 1 |
| Communications receiver system (probably digital, but voice also if desired, multi-channel, probably operating between 30 and 76 MHz. Capable receiving designation requests from net control station and of interfacing with mini-computer) | 1 |
| Prime power supply (solar or petroleum fueled generator) | 1 |

TRILATERATION GROUND DESIGNATION SYSTEM
GENERATION BREAKDOWN (Con't)

Slave Transceivers (2 req'd):

| <u>Item</u> | <u>No. Req'd</u> |
|--|------------------|
| Antenna (same as for master Xmtr.) | 1 |
| RF power amplifier | 1 |
| Modulator (pulse or FM) | 1 |
| RF source (approx. 100 MHz) | 1 |
| Driver | 1 |
| Receiver system (with address decoder, 10 MHz clock and differentiator or discriminator-superheterodyne with RF,IF and video similar to designation receivers) | 1 |
| Transmit/receive switch | 1 |
| Prime power supply (solar or petroleum fueled generator) | 1 |

TRILATERATION GROUND DESIGNATION SYSTEM
GENERATION BREAKDOWN (Con't)

Trucks (3 req'd):

Probably modified army 6 x 6

Small shelter (3 req'd):

Probably standard small army shelter (hut)

Antenna mount and elevating device (3 req'd):

Elevating device can be hydraulically operated
"Hi-reach" type, specially designed. Other
types possible.

APPENDIX E

VISUAL CUEING

VISUAL CUEING

A. INTRODUCTION

The problem of visual cueing is to simulate the visible, and when used, aural effects of fictitious field artillery and mortar rounds in a manner useful both as warning to the personnel under fire, as well as for spotting to forward observers (FOs). In some systems concepts, an audio report may be required. While "hard" requirements for such a device are not easily derived, several factors must be considered in selection:

- Fidelity/training value;
- Utilization/Deployment;
- Safety; and
- Development.

These four items will be discussed in the following paragraphs and are applied to the system concepts identified in the main body of this report, although the emphasis is placed on the Systems 4 and 4-A.

1. Fidelity

The authenticity to which the visual cue reproduces an actual event is the prime determinant of its ultimate value in a field exercise. With the exception of the audio report (which could be used to provide the audio "cue", a function performed synthetically in Systems 4 and 4-A with a laser beam), the visual cue should possess the following characteristics:

- Point of burst initiation -- at called for altitude, or safe minimum for ground burst and with lateral coordinates the same as predicted point of impact (PIP) for single round or mean PIP for volleys simulated by a single cue;
- Detonation/flash -- exhibit the same physical attributes, such as temporal, spatial and spectral characteristics as would a real round; and
- Smoke cloud/debris -- the behavior of the cloud and to some extent, its visual appearance, such as shape and rise time, must be authentic, a fact probably more important than the preceding characteristic because the flash is only a transient phenomena.

It was from these considerations that such techniques as flash strobes of high power and common loudspeaker audio cue were rejected early in the study.

The device may be authentic, in that it replicates an actual physical event, yet may not be altogether useful in a training exercise. That is, certain physical characteristics of the device might need to be accentuated, somewhat at the expense of realism and simulation faithfulness, to enhance the training value. This accentuation would apply in particular to the use of the visual cue for FO adjust and registration fire missions. For example, the visual/audio cue operator might require enhanced optical contrast or color (such as a yellow cloud) to increase the detectability by FOs.

2. Utilization

The discussion of the fidelity of a potential candidate device or technique cannot be realistically separated from its intentioned use in the field. Ideally, the device should be covert in its activation -- that is, personnel seen in transit or in the process of implanting a visual cue device prior to actual kill by laser or other mechanism might reveal the imminent presence of indirect fire. In addition, the necessity of having to be in the actual location of the simulated round's impact may impose unacceptable time constraints on the visual cue operator (VACO), particularly in heavily forested, hilly terrain.

Pre-implantation of visual cues, which could be remotely detonated, are attractive for a small area and where there are but a limited number of pre-planned targets. This is a technique that is commonly employed in the entertainment field, but is not considered feasible here because of the large area to be covered and the certainty of unplanned, suppressive fires and large shifts from known points.

The visual cue device/method must be compatible with the system concept in which it is intended for use. In System 4, for example, the activation of the visual cue must closely follow the laser kill-cue operation. The visual cue could even occur in the midst of an extended suppressive fire. Thus, coordination is essential and it is desirable for the visual cue device to have a variable ballistic range to permit flexibility in selection of the launch point.

3. Safety

Under normal operating conditions, the device employed must be safe, both to the operator and "victims", presenting only imperceptible hazards from exploding fragments, chemical and toxic materials, incendiary matter or from loud aural reports or bright flashes. Consideration must also be given to safety under abnormal conditions -- for example, the danger to exposed personnel from impacting, non-exploding rounds (duds) must be minimized. It is almost axiomatic that handling and use of pyrotechnic/explosive devices require considerable operator caution and experience. This is implicit in the work to follow and emphasis henceforth is placed on the dynamical hazards. While it is not within the scope of this report to determine safety requirements, the comments which follow set guidelines which, if adopted, are expected to ensure reasonable and adequate safety to both evaluation and training personnel.

One of these guidelines is an energy of impact from unexploded rounds of less than about 10^2 slug-ft-sec², or equivalent to that of a fast-pitched baseball. This makes the probability of serious injury almost impossible, even if a person is struck. The probability of a round striking an individual is variable and hard to predict, but varies from about 10^{-2} for prone, exposed troops in tight defensive formations in open terrain, to about 10^{-4} for standing troops under heavy tree cover. No value has been assigned to the probability of encountering a dud (not expected to be any worse than 10^{-4}). The probability that a dud falls among such a tight group of prone individuals is probably no more than 10^{-2} . Therefore, the probability of a dud round striking an individual is no more than $(10^{-4})(10^{-4})$, or about 10^{-8} . If there are 1,000 cueing rounds fired during the exercise, then there is one chance in 10^5 (one in 100,000) that a soldier will be struck during the exercise.

A second aspect of safety is that the bursting round must not cause damage to eyes or ears from bursts that are too close. This consideration has to be controlled by the fuse delay time for remote, ballistically projected rounds and from operator care and training for rounds detonated in the proximity of troops.

4. Development

A search for existing pyrotechnic devices suitable for the audio-visual (A/V) cue has been unsuccessful. The principal need is for an adequate-size smoke puff of good persistence. It is deemed necessary to develop a new round and as noted in the annex to this appendix there appears to be a feasible scope of technology available. The specifications for ballistic and A/V performance needed are not rigid, and a development by industry under the cognizance of appropriate Government agencies is certainly feasible along the general lines suggested herein.

B. DEVICES/METHODS

1. Actual Battery Use

Ideally, rounds capable of being fired from the pieces themselves and possessing the same ballistic properties as the rounds called for would provide the most faithful reproduction, particularly for the mortar rounds. The shells would be timed to burst at a safe (100 to 200 ft) height, or allowed to descend on a parachute, with a burst charge replacing the high explosive (HE) in a frangible case. There is considerable danger from rounds that are duds. A 10 lb (81 mm) or 25 lb (4.2 in.) projectile striking an individual at velocities > 100 m/sec on the head or body would probably prove lethal. Also, the debris from rounds that do explode might be unsafe at low burst heights. When the field artillery battery does not actually exist in an exercise, simulation of these weapons by this method is not possible. This fact, in addition to the safety hazards involved, has forced the recommendation that this approach not be used.

2. Visual Cue Projector

a. Mortar

The next most desirable method of audio/visual cueing would be to use a device capable of safely and accurately placing a round over the intended "kill-cue" zone at ranges from about 0.10 to 1.0 km. These are the ranges at which the laser system operator (System 4) is required to work and though the VACO is not necessarily located with the laser system simulator, these range requirements do serve as a basis for discussion. In the other system concepts, a one km maximum range is estimated to be that consistent with achievable accuracy.

The device could clearly assume many gradations of form and complexity, but simplicity is desirable. For example, an accurate and reliable proximity fuse would greatly enhance the capability of most systems of this type. The device would also increase complexity and cost and would reduce reliability.

In one form, the system would be no more than a small mortar, projecting a finned round of about 1/3 lb to the required range. For a fixed time fuse, elevation angle and muzzle velocity would have to be variable to achieve a nominal height of burst between 75 and 100 ft. If the fuse time could be varied, either by pre-set or proximity fuses, the muzzle velocity changes as obtained by different charges, could be dispensed with. Errors in elevation angle setting, changes in muzzle velocity from standard, errors in fuse time, and winds will cause the projectile to not explode directly over the intended point or at the design height of burst (HOB).

Rounds having longer ranges require higher muzzle velocity, depending on the ballistic coefficient of the round. For a half-pound, fin-stabilized projectile of 40 mm-diameter hemispherical forebody shape, the ballistic coefficient will be about 10^5 ft, or about one-tenth that of a 81 mm mortar round. A HOB of 100 ft at a 1,000 m range would require a muzzle velocity of 750 ft/sec in standard atmospheric conditions.

This firing creates a momentum of about twice that of a large gauge shotgun. Unless the weapon launch mechanism is made quite heavy, the recoil velocity will be dangerous for a hand-held device. The difficulty of quickly and efficiently loading a hand-held breech loading device, with variable charges, also weighs heavily against this type of apparatus.

In addition, the accuracy with which a hand-held device, even with auxiliary sighting aids, could place a shot over a 1 km distant target is suspect. At this range, a circular error probable (CEP) of 50 m would not be unexpected, even in only moderate (5 to 10 knot) winds. The only way to successfully use a cue projector of this type without cumbersomeness, would be ground emplacement, use of firing tables, four to five variable charges and variable elevation angle for pre-timed detonations.

The discussion thus far has neglected safety, principally in respect to the problem of unexploded rounds impacting near or on personnel. To reduce the velocity of these duds to safe levels at impact, (60 to 80 ft/sec) requires that the ballistic coefficient be made about 5×10^3 ft. To obtain the 1 km maximum range with that coefficient would require an unfeasible muzzle velocity and make the round more susceptible to winds. In fact, the hazards would actually increase near the muzzle. Considering the higher velocity, these rounds would be unacceptable since the lethal impact velocity should be much smaller than 750 ft/sec.

While this approach (that is, ground emplacement as in an actual mortar) has considerable merit and in its most useful refinement offers accurate and relatively realistic placement of visual cues that are useable both to FOs and victim troops and alleviates many potential deployment problems, it has not been selected as the best candidate. This decision was made principally because of the extensive development required. In addition, since the danger of impact of unexploded rounds is of great importance, their velocity should be less than 160 ft/sec at impact with 60 to 80 ft/sec highly desirable. To achieve this goal, a low ballistic coefficient is required of the projectile, so that to reach 1 km requires much higher velocities than the 750 ft/sec mentioned earlier.

b. Grenade Launcher

A second, and in ILS' opinion, more desirable method is to use a round capable of fire from a 40 mm grenade launcher (M-79) or other individual weapon. At least one such round, the M27A1B1 Air Burst Simulator, already exists. It is 8.92 in. long, 1.88 in. in diameter and weighs 0.58 lb. The simulator has a plastic body with rounded nose, which is screwed into the aluminum fuse housing/fin stabilizer. A propelling charge of 9 grains of smokeless powder ejects the device out of the launcher at about 250 ft/sec. After a time-train fuse burns for about six sec, the simulator bursts, accompanied by a bright flash, a puff of grey smoke which is visible up to 3,000 yards, and a report audible at ranges of at least 2,000 yards. The projectile has a ballistic coefficient of greater than 2×10^5 ft and can achieve ranges of between 0.25 and 0.30 km at elevation angles greater than 30° , but less than 45° and bursts at heights between 80 and 260 ft. There is no convenient way of varying (shortening) range because the higher elevation angles give HOBs between 400 and 600 ft. These altitudes are probably unuseable by either FOs or victim troops.

If the launch angle is reduced to below 30°, which is a method of increasing range, the probability of low and dangerous bursts would be increased, particularly in uneven and hilly terrain. Removal of some of the bursting charge may be required for use of this round.

For launch elevation angles between 30° and 45°, the velocity of an unexploded round at impact is about 140 ft/sec, which is dangerous with respect to physical injury to personnel. Unfortunately, as the ballistic coefficient is decreased, the range also decreases.

Even if the launcher and round could be used "as is", the addition of an accurate azimuth sighting device is required and changes to the range ladder sight are required.

An alternative is to use high muzzle velocities, but higher drag coefficients, allowing the round to slow considerably before impact. An example of a typical trajectory is shown in Figure E-1 for a 30° elevation launch condition. For a ±20% variation in muzzle velocity (±10% is achievable) and a fuse time of 2.5 ± 0.5 sec, the range varies from 260 to 380 ft with heights of burst from 80 to 150 ft. If a ±10° variation about the nominal 30° is assumed, the range varies from 275 to 360 ft if the muzzle velocity is held to ±10%. The heights of burst are between 50 and 180 ft, where the nominal values are a range of 315 ft and an HOB of 120 ft. Noteworthy is the fact that the terminal velocity is 65 ft/sec, which is well into the safe zone for personnel.

ILS has engaged AAI, Inc. for study of a new grenade launcher round for ranges of 125 to 150 ft, with HOBs of about 60 ft. The report from AAI is contained in annex I of this appendix.

The precise design and performance parameters must await a more detailed evaluation, and establishment of tradeoff criteria between the four factors identified at the beginning of this appendix.

Another device, the M74A1 round is available, which is fired from pyrotechnic pistol AN-M8, giving a nominal HOB of 100 ft and a horizontal range of about 250 ft when fired at an elevation angle of 45°. The round, which weighs about 0.3 lb, is safer than the M27A1B1 simulator because it is lighter and personnel would be less immune from the effects of duds than with the M27A1B1 device. The principal effect of the M74A1 is an explosive report. The smoke cue is very probably inadequate.

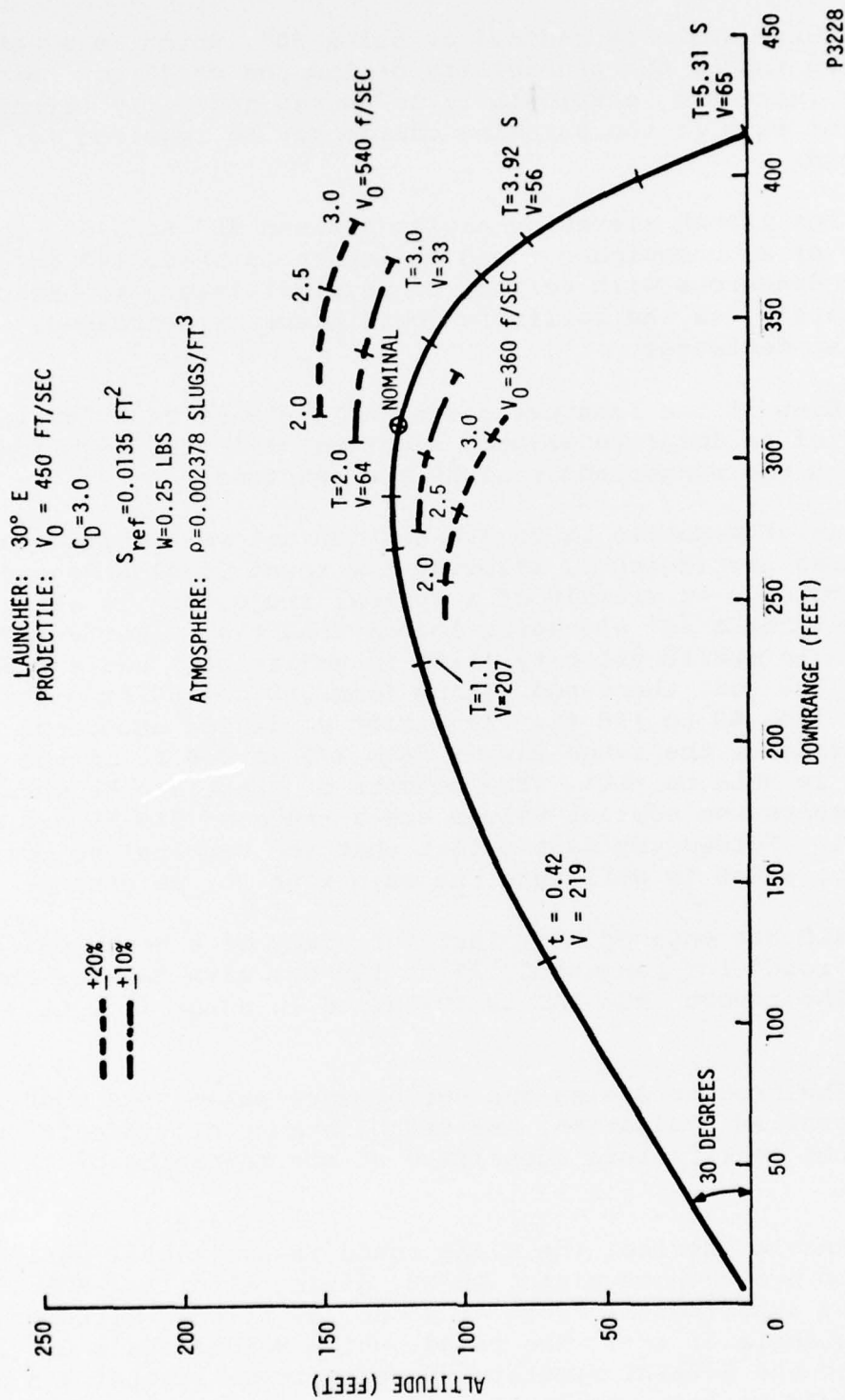

Figure E-1. Typical Trajectory for a 30° Elevation Launch Condition

c. Site Projectors

One possible method is to use personnel to emplace the device at the site -- that is, at the location of the simulated round impact. This method suffers from a lack of covertness, where the individual deploying the device might be seen by the victim troops. This method uses devices that are available and easily obtained. Of particular interest is the Army Simulator, Projective Air Burst: Charge, Smoke Puff. This device is used with a smoke puff discharger to simulate the appearance of the burst of an artillery projectile near the ground by producing a puff of white smoke, visible up to 3,000 yards by ground observers. The simulator is placed into the ground, or in a tree, and is discharged by pulling a lanyard, which fires a cap percussion primer. Nothing is ejected except the puff of smoke.

Under contract to ILS, A.P.C. Fireworks Division and Pyro Display Co., Inc. of Sebring, Florida, Mr. E. Vickers furnished the design and five prototype fixed pyrotechnic devices which he demonstrated. The results were unimpressive.

In addition, at least one device is available commercially. The Schermuly (England) hand fired Smoke Puff Rocket ejects a large puff of brown smoke, accompanied by a loud report and bright flash, at an altitude of 200 to 1,000 ft, depending on elevation angle at firing. This device is considered quite hazardous.

C. ADDITIONAL DEVELOPMENT

To obtain innovative ideas outside the conventional engineering channels, several corporations in the entertainment field were consulted about the visual cue problem. These included Disney Enterprises (Anaheim, California) and Presentations-South (Orlando, Florida). Appreciations are extended to Mr. Tom Craven of Walt Disney World and Mr. Bob Buck of Presentations-South for their suggestions, which are hereby respectfully acknowledged.

D. CONCLUSIONS

The best visual cue device from the standpoint of safety, fidelity and utilization would be a M-79 grenade launcher, fitted with auxiliary sights and using a new low ballistic coefficient round of between 0.25 and 0.33 lb. A range of 0.10 km and a HOB of 75 to 100 ft are the nominal specifications. With a ballistic coefficient of 10^4 ft, the impact velocity for duds will be less than 80 ft/sec, which is well within the safe zone for personnel.

While current devices, both in commercial and military form, exhibit desirable characteristics, none of them possess the aggregate of the desired features. New devices require development, but none require high risk, state-of-the-art extensions.

ANNEX 1

TO APPENDIX E

AUDIO VISUAL CUEING SUBSYSTEM
FOR
INDIRECT/AREA FIRE EFFECTS SIMULATION



AUDIO VISUAL CUEING SUBSYSTEM
FOR
INDIRECT/AREA FIRE EFFECTS SIMULATION

Report No. ER-8837

October 1976
Date



AUDIO VISUAL CUEING SUBSYSTEM
FOR
INDIRECT/AREA FIRE EFFECTS SIMULATION

I. INTRODUCTION

Under contract to International Laser Systems, Inc., AAI Corporation has conducted a concept feasibility study of an A/V cueing system based on the M-79 40mm grenade launcher.

Design goals for the system were:

- o Event height of 60 ± 10 feet.
- o Visible-cue smoke cloud approximately 15 feet in diameter having a contrast of $\pm 20\%$ with cloud, white smoke or tree background.
- o Audible to ranges of 2 km while not exceeding 140 db on the ground directly below the burst.
- o High degree of safety both for shooter and troops in the area. Low terminal velocity and self-disarm and/or destruct on ground impact.

Additionally, the M-79 grenade launcher was analyzed to study both the feasibility and advisability of providing a safety which would inhibit firing at elevation angles of less than 45° .



II. A/V CARTRIDGE

A. Projectile Design

The basic concept for the projectile design consists of a frangible 40mm projectile filled with a pyrotechnic mix and fuzed with a simple pyrotechnic delay that is initiated by the propellant gases at launch. Expiration of the time delay causes the mix to explode in mid-air producing both visual and audible cues. The projectile body is of a brittle plastic material and is further prescored to ensure break-up into small pieces. In the unlikely event that the delay fails to ignite, or burns out, the frangible nature of the projectile will cause it to fracture and spill its contents on ground impact. This fracturing will virtually eliminate the possibility of a subsequent explosion of the round and will also tend to reduce the impact force should the dud hit a person or piece of equipment in the field. In order to minimize the fragmentation hazard the projectile should be as small and light as possible consistent with the charge necessary to produce the desired cloud size. Likewise, the launch velocity should be as low as possible, consistent with the altitude and range requirements, in order to minimize the potential damage that could be caused by a dud.

A number of trajectories were computed to determine the aeroballistic characteristics of candidate designs. Based on experience with similar spotting and cueing rounds it is estimated that a round weight of .2 to .3 pounds will be required to provide an adequate signature. A stand-off range of about 125 feet was deemed desirable so that the shooter would



not have to actually enter the area to be cued. Three munition concepts were postulated - spin stabilized, tumbling, and drag augmented. The spin stabilized round had a conventional 40mm grenade shape with an estimated drag coefficient of .25. The tumbling round had an estimated $C_D = 1.0$, while the drag augmented projectile had deployable drag vanes which increase the C_D to 3.2. In all cases the reference area was based on the body diameter. Pertinent results are tabulated in Table I.

It can be seen that for the weights of interest a 45° launch at 100 fps will produce the desired nominal burst height and stand-off. Further, the time to the event point is nominally 2 seconds.

The tumbling projectiles have somewhat lower terminal velocities than their stable counterparts; however, the random nature of the impact may make it more difficult to ensure a decisive break-up on impact.

It is interesting to note that except for the drag augmented configuration the trajectory to the burst point is insensitive to both projectile weight and to whether or not the projectile is stable. Thus, the designer has considerable freedom in this respect. Also, exact control of the time delay is not important in terms of placement accuracy. At the summit of the trajectory the projectiles are traveling about 60 fps.

A simple, inexpensive 2-second time delay will typically vary by $\pm .3$ seconds. Thus, the projectile would have a horizontal placement accuracy due to fuze tolerances of about ± 18 feet. The vertical change would be ± 2 feet.



Table I - Ballistic Characteristics

| Weight Lb. | Launch Angle Deg. | Launch Velocity FPS | Max. Height Ft. | Time to Max. Height Sec. | Range at Max. Height Ft. | Range at Impact Ft. | Velocity at Impact FPS |
|---------------|-------------------------|---------------------------|-----------------------|--------------------------------|--------------------------------|---------------------------|------------------------------|
| .2(S) | 45 | 100 | 63 | 2.0 | 137 | 269 | 87 |
| .2(T) | 45 | 100 | 60 | 1.8 | 122 | 197 | 67 |
| .3(S) | 45 | 100 | 73 | 2.1 | 141 | 281 | 91 |
| .3(T) | 45 | 100 | 64 | 1.9 | 133 | 222 | 74 |
| .3(DA) | 30 | 200 | 65 | 1.7 | 172 | 282 | 62 |

(S) = Stable

(T) = Tumble

(DA) = Drag Augmented



The drag augmented version has the lowest impact velocity; however it requires a much higher muzzle velocity and involves substantially more parts which will contribute to the fragmentation potential. The higher muzzle velocity is probably a liability in terms of increased hazard near the muzzle in the event of an accidental or low angle launch. At the present time the potential disadvantages of this concept appear to outweigh the advantages.

Figure 1 illustrates a projectile concept. The body is molded from polystyrene and includes a rotating band and a web in the base which houses two pyrotechnic time delay trains with interrupter type safe and arming devices. The dual delay trains provide redundant systems for initiation of the smoke mix. The interrupter pins prevent ignition of the first fire mix when they are in place. In the normal loaded configuration the pins are retained by the walls of the cartridge case. Firing of the cartridge introduces hot propellant gases which accelerate the projectile and at the same time ignite the delay trains. As the projectile engages the rifling centrifugal forces are developed and the interrupter pins become bore riders. At muzzle exit the pins are free to fly out of their cavities thus exposing the first fire mix to the delay column. Expiration of the delay will cause it to flash across to the first fire mix which will easily ignite and propagate to the smoke mix.

It will be noted that a stable configuration has been shown. There are several reasons for this choice. First, it will be necessary to engage the rifling in order to prevent gas leakage leading to variations in muzzle velocity. While a slip type rotating band is possible, the spin of the



projectile is useful as a means of arming the projectile by ejecting the interrupter pins. Finally, the spin stabilized projectile will impact in a nose-down attitude if it fails to function in mid-air. Knowing the attitude on impact should facilitate the design of a projectile which will break up on impact. On the other hand, the stable and non-stable configurations have virtually identical trajectories up to the event point. Hence, if other considerations, such as an overly long round because of the amount of fill needed, lead to a non-stable configuration it will have little effect on the burst height or range.

AAI has developed a similar plastic 40mm grenade for use as a low cost training cartridge. In that projectile the fill is a red powder which is dispersed on impact. It was found that by molding a circumferential groove which acts as a stress riser around the nose very reliable break-up of the projectile could be achieved. The material used was polystyrene.

For the present application it is anticipated that several grooves would be molded into the body in order to promote break-up into small pieces. Elimination of fragmentation hazards to personnel directly below the burst point probably represents the most significant design challenge in the development of an A/V cueing round. Most, if not all, pyrotechnic mixes capable of producing the desired signature are classed as low explosives when used in the quantities envisioned here. Thus, given enough confinement, very substantial explosive forces and subsequently high fragment velocities will be produced.

Figure 1
Design Concept of 40mm A/V Cueing Round

Diameter: 40mm
Weight: .2 Lb.
Launch Velocity: 100 fps
Burst Height: 60 Ft.
Payload Volume: 3.7 In.³
Body Material: Polystyrene

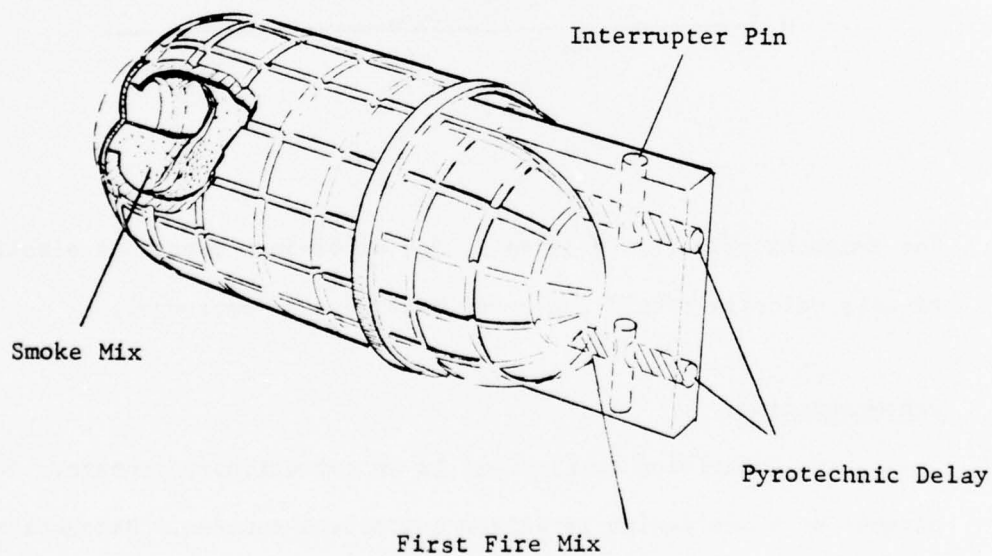



The figure below shows the velocity decay rate for a .25" x .25" x .080" plastic fragment for initial velocities of 2000 and 4000 fps.

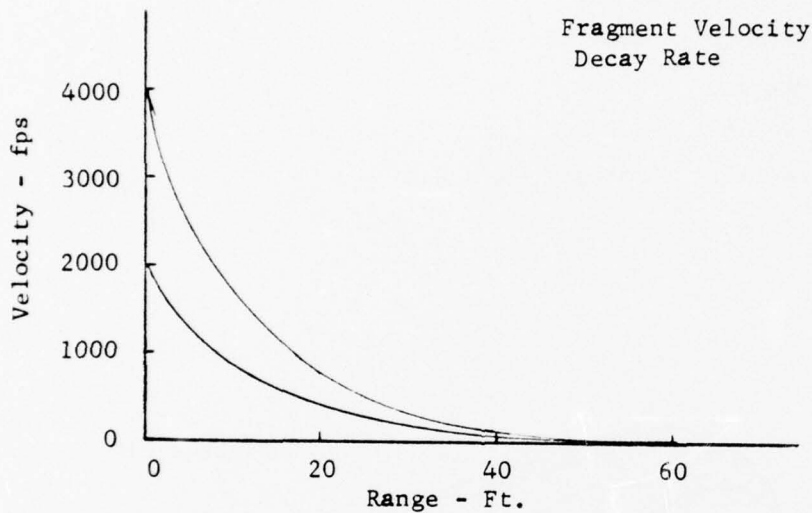

The fragment velocity is 13 to 27 fps at 60-foot range. A plastic fragment of this velocity should not prove hazardous to personnel.

Recommendation:

Ammunition development is an evolutionary process. One's first attempt at a new design is seldom a complete success. Recognizing this, the primary recommendation regarding the projectile configuration is that a well planned, comprehensive development program be anticipated and planned for.



Based on the studies conducted on this program, a 40mm projectile fired from an M-79 grenade launcher should provide a safe and adequate cueing round. The projectile configuration shown in Figure 1 is thought to represent a reasonable starting point for the round development. Salient features are molded plastic design, spin stabilized, pyrotechnic time delay, weight .2 lb, launch velocity 100 fps, and launch angle 45° .



B. Pyrotechnic Mix

The pyrotechnic mix should produce an instantaneous, dense cloud which provides some contrast to other white smokes. It should also provide a loud report but not exceed 140 db on the ground directly below the burst. Finally it is desirable to achieve these characteristics while producing the lowest possible fragment velocities.

Several candidate mixtures are available. Since, to our knowledge, none of them have been used in precisely the manner now anticipated, it is recommended that a test program be conducted in which the cloud size, acoustic report, and fragmentation characteristics be measured. The following mixtures are likely candidates:

Mixture A

| | |
|-----------------------|-----|
| Hexachlorobenzene | 15% |
| Potassium Perchlorate | 20% |
| Zinc dust | 55% |
| Black aluminum | 10% |

Present use: 170 grain charge used in AAI tank gun fire simulator.

Mixture B

| | |
|-----------------------|-----|
| Potassium Perchlorate | 38% |
| Iron Powder | 45% |
| Aluminum powder | 16% |
| Cab-o-sil | 1% |

Present use: 300 gram charge used in experimental AAI 105mm spotting round. Produces orange cloud.



Mixture C

| | |
|--------------------------------|-----|
| Calcium Carbonate | 50% |
| Anthracene | 16% |
| Potassium Chlorate | 17% |
| FFFF _g Black Powder | 17% |

Present use: Recommended by Ga. Tech investigators (E. K. Reedy, et al, Indirect Fire Instrumentation Study Final Report, EES/GIT Project A-1697-000, Feb. 1976)

Mixtures A and C when fired from shotgun shells produce white clouds about half as large as the desired 15 foot diameter. The 300 gram charge of mixture B produces an orange cloud some 20 to 30 feet in diameter. Thus, the 50 to 70 gram fill that a 40mm projectile can carry should produce the desired cloud size.

The Ga. Tech investigators reported being able to hear the report from their device at a range of 2 Km. The test conditions appeared to favor the sound transmission, but the results are encouraging with regard to the present application.

Recommendation:

Conduct test program using the mixtures suggested herein. Measure cloud size, acoustic report, and fragment velocities. Achieving the desired cloud size, contrast, and the acoustic report appear to be within the state of the art using a 40mm size device.



C. Delay Train

A number of delay train mixes are available. One which AAI has used with outstanding reliability over a number of years consists of a mixture of 11% zirconium powder and 89% barium chromate consolidated at 80,000 psi. A .2-inch long column provides a $2 \pm .3$ second delay. This delay column is used in a tear gas grenade manufactured by AAI and has proven to be quite reliable.

Usually slow burning delays need to be fairly large in diameter in order to insure complete propagation. In the present case we want the smallest diameter practical because the larger the train diameter the thicker the plastic parts and correspondingly the greater the fragmentation hazard. In view of the need for good reliability, a minimum delay train diameter of .125 inches should be considered.

A somewhat more sensitive mixture may be needed as a first fire to transfer the propellant gas flame to the delay train and also to promote transfer of the delay train flame to the smoke mix. A mixture of 40% zirconium -60% barium chromate will serve that purpose.

Recommendation:

A proven delay train mix should be used if possible. A .2 inch long train, .125 inches in diameter composed of 11% zirconium -89% barium chromate consolidated at 80,000 psi should provide a reliable delay of the proper duration. A dual train should be considered because of the desire for exceptional reliability.

III. WEAPON

A study was made to explore the feasibility of modifying the M-79 trigger group to inhibit firing at elevation angles of less than 45° . In this study we considered gravity actuated safety mechanisms which were effectively beyond the control of the shooter. That is, at elevation angles of less than 45° the safety was automatically cammed into position while at higher elevation angles it automatically moved to the fire position. Figures 2 and 3 show two of the concepts that evolved from this preliminary study. In each case a pendulum type device acts on a modified trigger to lock it when the elevation angle is less than 45° .

Consideration was also given to blocking the hammer or firing pin. These approaches were abandoned because they appeared to create safety problems. The M-79 grenade launcher has no charging handle as such. There is a cocking lever which automatically cocks the weapon each time it is broken open to insert a new grenade. Conversely, there is no way to recock the weapon once the hammer has started to fall except to break the weapon open. Opening the weapon with the partially fallen hammer being restrained by a gravity operated cam or lock appeared to invite an inadvertent firing of the weapon.

While the trigger locks shown in Figures 2 and 3 could be made to work it is doubtful that they would add much in the way of safety to the overall problem. First of all the impact velocity of a dud is only 10 or 20 feet per second less than the launch velocity. Thus, the damage potential

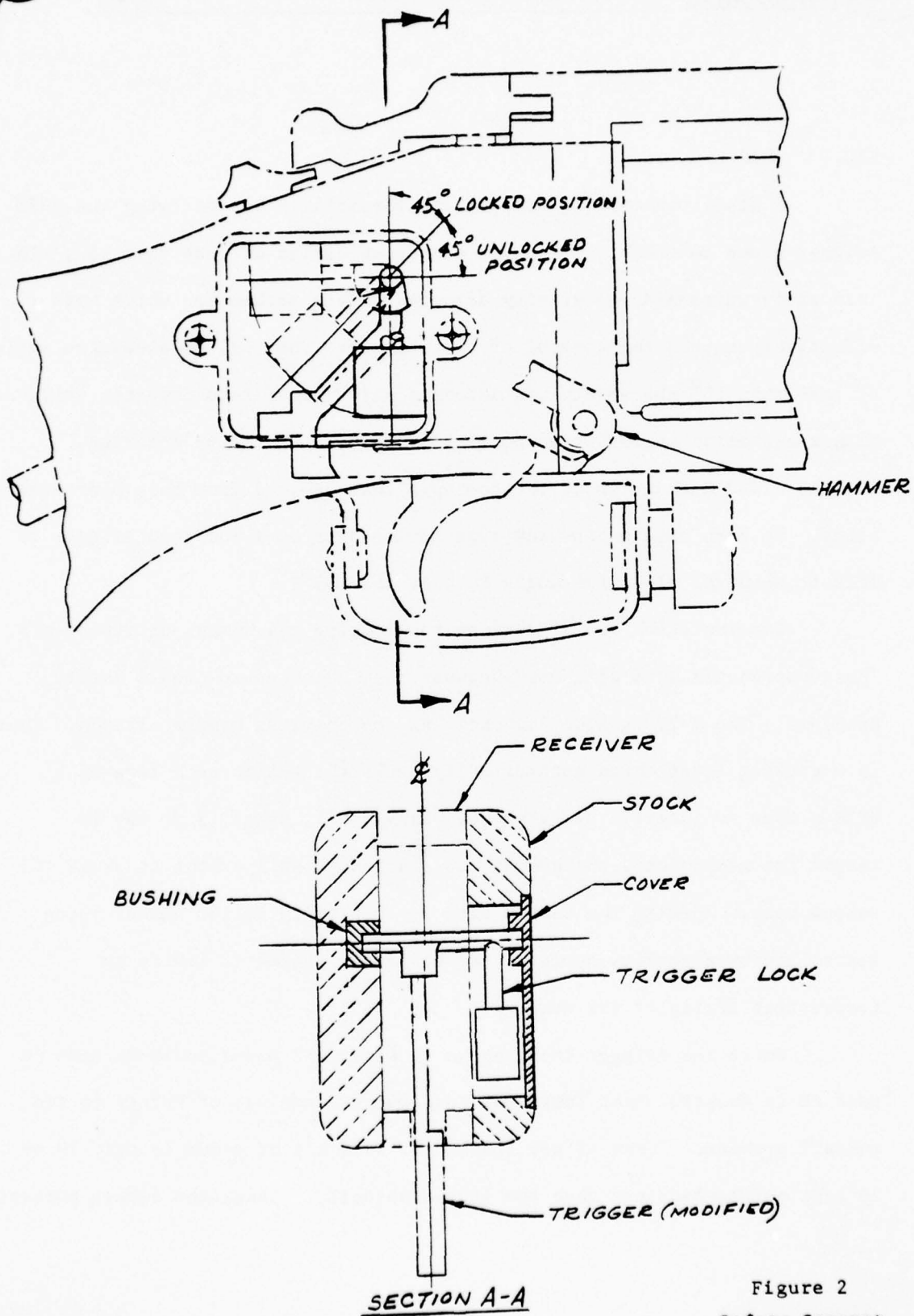
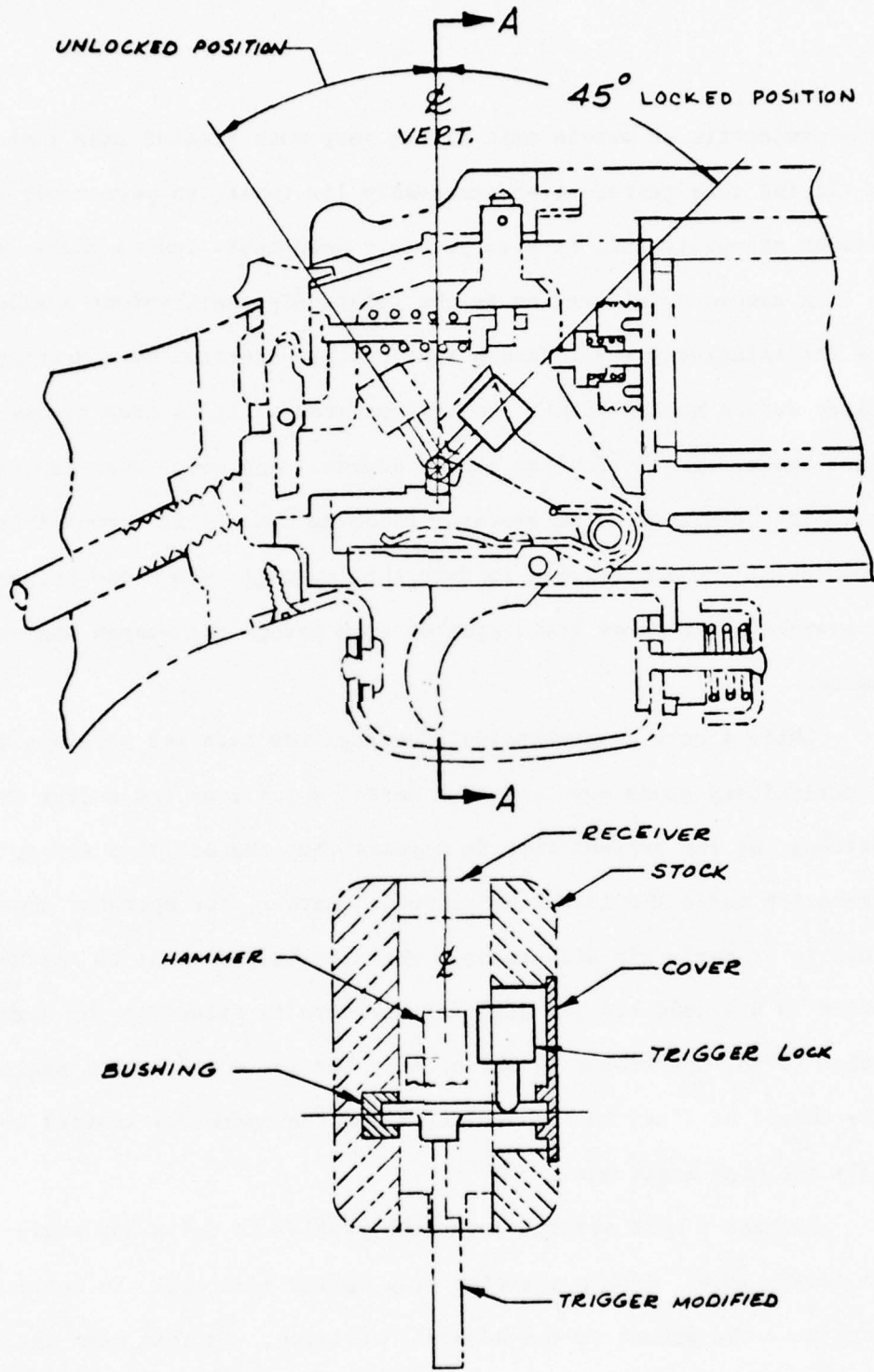

Figure 2
Safety Concept



SECTION A-A

Figure 3
Safety Concept



of the projectile at muzzle exit is not very much greater than that of a dud. If the duds represent an acceptably low threat to personnel, then the round at muzzle exit is also probably acceptably low in threat level.

A second consideration is the relatively small volume available and hence the relatively small forces that can be generated by a gravity operated device housed within the trigger group. It is easy to envision a small amount of dirt fouling such a device. One would then have the very unsafe condition of an operator thinking that it is "impossible" to fire his weapon at low angles when in fact the low angle block was inoperative, or conversely, the block would stay on even though the weapon was properly elevated.

While a more comprehensive investigation than was possible during this preliminary study may lead to a design which does not suffer from these objections, at the present time it appears that the use of a safety based on elevation angle should not be pursued. Rather, the operator should be trained to properly aim his weapon. When the ladder sight on the M-79 launcher is extended and its sighting aperture is raised to the highest position (375M) the weapon is essentially set for a 45° launch angle. The sights should be fixed in this position and the operators trained to operate in only the high angle mode.

Perhaps a more serious potential problem is not a low angle launch but a launch at 45° from a position in a valley such that the burst point is very near the ground on the adjacent hillside. In this case the projectile would be exploding much closer than 60 feet to a person located on the

hillside and hence the possible threat of blast or fragmentation damage is much greater. Short of repositioning launchers before an exercise starts it appears that the only way to minimize this threat is to properly train the operator in the safe deployment of the device.

Recommendation:

A safety device to inhibit low angle firings is probably not worthwhile. The shooters should be properly trained for high angle firings.



IV. COST ESTIMATES

Based on past experience with similar 40mm ammunition, it is estimated that the cost to develop a 40mm audio visual cueing round of the type described in this report would be \$100,000 to \$150,000. This cost includes development through operational testing.

It is estimated that the cost to produce the 40mm A/V cartridge in quantities of 100,000 rounds per year would be \$5 to \$7 per round.



V. SUMMARY OF FINDINGS AND RECOMMENDATIONS

1. A molded plastic 40mm projectile weighing about .2 lb and containing a pyrotechnic delay and pyrotechnic flash mix should, when launched at 100 fps and 45° angle, provide a suitable A/V cueing round for indirect fire simulation.
2. Conventional pyrotechnics should be capable of providing the desired signature and time delay.
3. It appears feasible to develop a round of sufficient reliability and low fragmentation potential.
4. Modifications to the weapon are not recommended, rather the operator should be thoroughly indoctrinated with the proper deployment of this device.
5. The estimated cost to develop the A/V cartridge is \$100,000 to \$150,000. The estimated cost in production is \$5 to \$7 per round.

APPENDIX F

SHELL SMOKE

SHELL SMOKE

A. PURPOSE

Smoke operations are conducted to reduce the effectiveness of hostile, aimed fire, deceive the enemy as to the location and activities of friendly troops and installations, prevent enemy visual ground and air observation, increase the problems of vehicular movement, and of communications, command and control of enemy activities. Smoke is placed on enemy troops or installations, between the enemy and friendly troops and installations, or on friendly troops and installations. In addition, signaling smoke, such as the marking of friendly positions as the transmission of specific messages in prearranged color codes, is likely to be employed.

Depending on the tactical and operational environment, smoke may be developed by ground emplaced generators, pots or grenades. They can be delivered in, or dropped from, fixed or rotary wing aircraft in the form of bombs, (bomblets) or air dropped smoke pots, or generated by artillery and mortars. It is the last case that is of importance here.

The principle use of this type of fire is smoke obscuration, where the rounds are placed on enemy positions to deny him effective visual observation of friendly territory, or generation of smoke curtains (screens) designed for the same purpose, except that the curtain is used mainly at or near the forward edge of the battle area (FEBA), and is a dense, vertical development of smoke rather than a horizontal blanket spread over an area. The curtain requires less expenditure of ammunition and does not inhibit friendly aerial observation and assault of enemy positions. For a given weapon, the required spacing between rounds, and the rate of fire is a function of the wind velocity and prevailing atmospheric conditions. For example, to establish a 500-m smoke curtain in a 13-knot following wind, under ideal inversion conditions, requires about two-155 mm hexachloroethane-zinc oxide-aluminum (HC) rounds-per-minute per impact point, placed 27 m apart. Weapon dispersion would increase the required rate of fire, or in actual use, the number of guns, because the round-to-round dispersion of a single tube is greater than the desired impact point separation. In this instance, the required expenditure of ammunition is large, and this is not a good smoke mission.

B. PROBLEMS

The area to be covered with smoke can be extensive - several hundred meters long and 100 m deep, or as small as 25 m long. For a given weapon, the ammunition and delivery techniques can be quite varied, although mortar smoke rounds are limited to white phosphorous (WP) only.

It is difficult to cover and control smoke over large areas with pots or generators, because they typically must be spaced 25 to 50 m apart for good coverage, creating a potential deployment problem. However, in favorable wind conditions -- that is, approximately 5 knots parallel to the longitudinal axis of the order covered -- one or two pots aligned perpendicular to wind direction and downwind, are considered sufficient.

The weather effects, including wind velocity and inversion conditions, have an impact upon how the smoke behaves and to a lesser extent, determines the rate of fire of the battery whose actions are to be simulated.

Beyond the difficulty of covering the required area with smoke is the problem of smoke interference. The problems discussed above are those common to, and which exist with any field exercise of this type -- that is, how to safely generate smoke in a manner that has meaning in a field exercise. These factors are not new and unique to this simulation and would apply to all the systems discussed in this report.

Unfortunately, the use of visible or near Infra-red (IR) GaAs lasers present another problem to the simulation/training exercise. If a call is made for mixed high explosive (HE) and Smoke, some coordination is required to prevent laser kill "degradation" from smoke attenuation of the transmitted laser code.

Safety could be a hazard in all of the devices and techniques considered, because chemical hazards exist with both HC and fog oil (SFG) smoke, with the former creating the requirement for protective masks for personnel exposed to high concentrations over long periods of time.

White phosphorus would not be used in any of the simulations, because of the incendiary hazards involved and from the toxicity resulting from the ensuing smoke.

Several methods of air dropping of smoke rounds exist (pots, bombs, bomblets) and all have the clear advantage of allowing high speed, reasonably accurate, and quite extensive, smoke deployment. Unfortunately, these methods all carry a prohibitive safety risk to personnel under the flight path of the carry vehicles. Development of new devices, such as drogues or parachutes to lower descent rate, thereby decreasing personnel risk, are not considered worthwhile.

C. SOLUTION

The only possible way to achieve a good smoke "simulation" is by close coordination with system net control station (SNCS). For rounds where kills with smoke are required, other than mixed high explosive (HE) and smoke, is white phosphorus (WP) only, the timing of kill-smoke will be controlled, with the kill designation occurring first or alternately, for long duration screens. This implies that the SNCS will determine and coordinate deployment methods, consisting of 10 lb, MI HC-filled (47% hexachlorethane, 47% tinc and 6% aluminum) smoke pots, useable by both the visual cuers (VACO) and by separate smoke teams. In addition to the smoke pots, the teams will have fog oil generators on jeep-towed trailers. If available, specially equipped helicopters ("Smokey the Bear") can initiate and maintain a screen 700 m long and 100 m deep for about 3.5 minutes using a 50 gallon fog oil tank¹. The helicopter must fly at speeds less than 90 knots and at altitudes of 50 to 60 ft. The availability of the helicopter is suspect and if aircraft are used the Mark 12 Mod 0 smoke tank could be employed where compatible.

The system control, through its monitoring of forward observer (FO) nets, will assess the smoke called for and the best way to achieve a good simulation. The SNCS will then direct smokers and/or visual cuers in the alignment and placement of pots or other devices. This approach would apply to all the systems considered in this report with the exception of laser designated systems.

¹ Atomized fog oil is injected into the hot turbine engine exhaust gasses to create the screen.

APPENDIX G

LASER WEAPON SIMULATOR - POINT KILL (LWS-P)

LASER WEAPON SIMULATOR - POINT KILL (LWS-P)

The LWS-P can be a simple adaptation of the MILES M-16 or Controller Gun laser.

The operational concept considers a single operator for both audio/visual cueing and for laser kill designation of selected troop or vehicle/materiel targets. Audio/visual cueing is accomplished with an M-203 or M-79 grenade launcher and a simulation cartridge (see Appendix E). Range is less than 400 meters. Therefore, the MILES laser adaptation is feasible and straight-forward.

Figure G-1 indicates the MILES dual barrel laser optics configuration. Normally, one barrel generates narrow beam kill and the other barrel generates wider beam near-miss. For the LWS-P both barrels are the wide beam (4 mr) configuration.

The MILES encoder normally generates two serial code words: 1) Man-kill (the M-16 kill code); and 2) near-miss. For the LWS-P the near miss code is changed to a direct fire kill code effective against all vehicle/materiel targets.

Each laser optic barrel is already driven only by its own code in the MILES system. Therefore, all that is required is to use a selector switch that enables only one barrel at a time. Such a switch is already being implemented in the MILES Controller Gun. The operator selects either Troop or Vehicle/Materiel mode depending on the target he is going to kill-designate.

If it is desirable to allow the operator to designate for audio cue, it is feasible to add a selector switch to change the man-kill code to the MILES near-miss code or even another distinctive code if a separate distinctive audio cue is implemented at the target.

Figure G-2 shows the LWS-P mounted to the M-79. For maximum safety a microswitch will be installed at the M-79 safety lever and wired in series with the LWS-P fire switch. The LWS-P fire switch will be a left-hand, thumb-operated push button. This design achieves minimum possible probability of accidental firing of a simulation round at troops. Of course, the best safety measure is dictated by operational procedure: load the simulation round and perform audio/visual cueing only after completing the kill designation ordered by the Fire Direction Center.

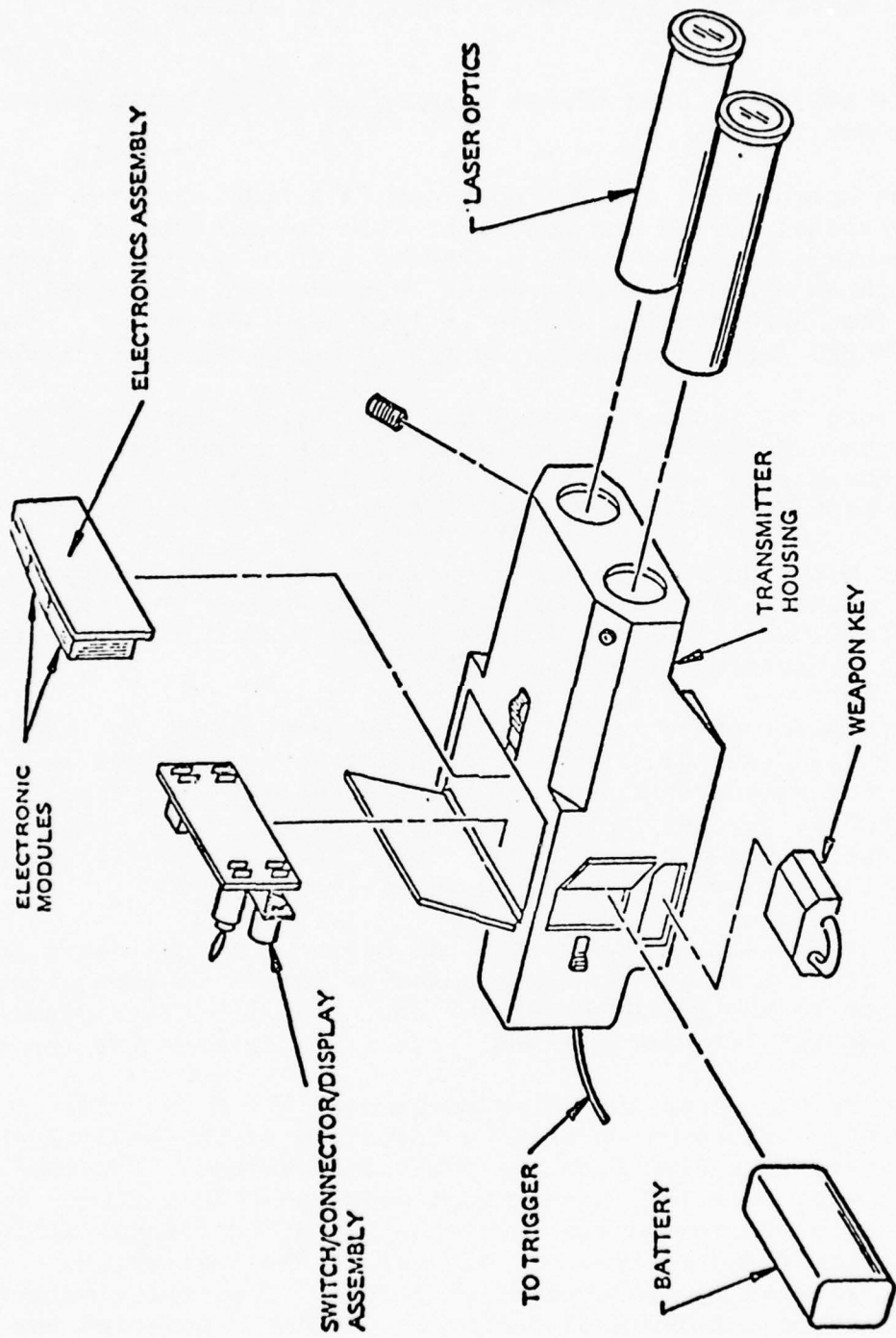

P3264

Figure G-1. Transmitter Modules

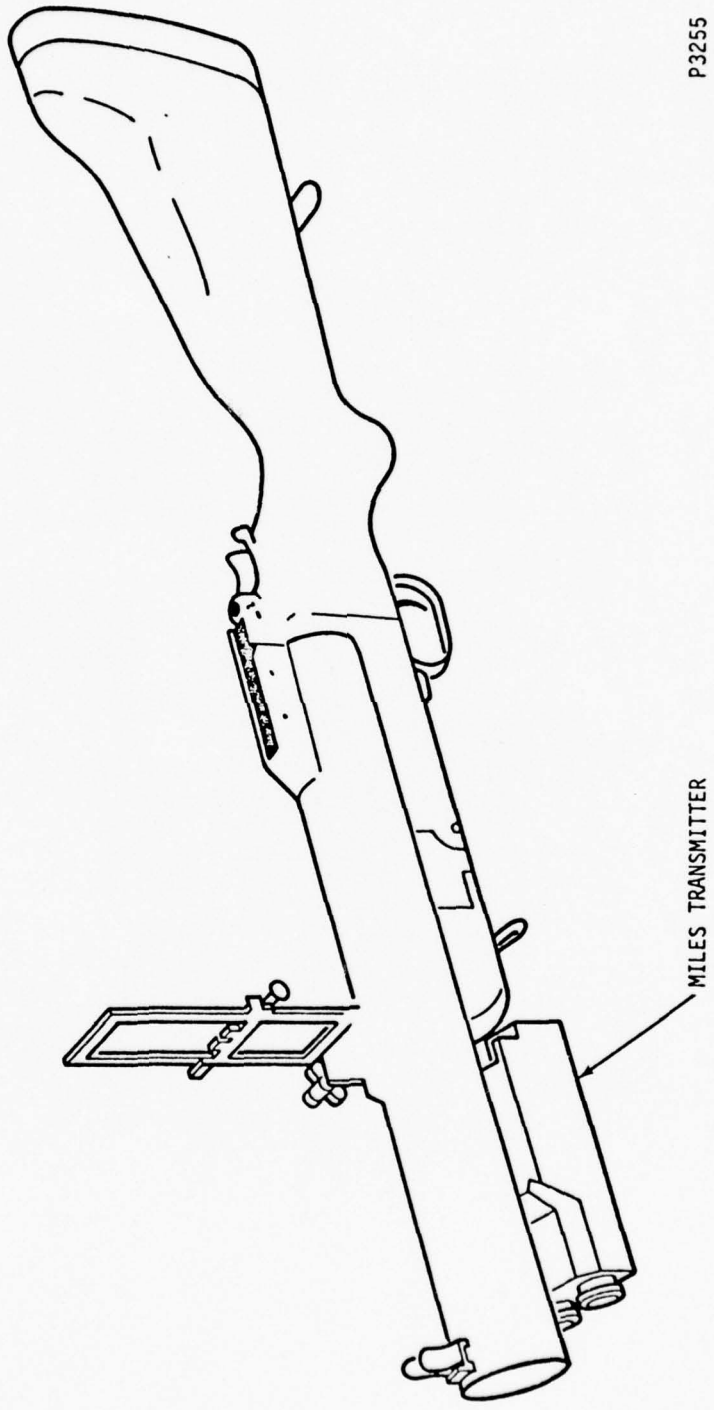

P3255

Figure G-2. Grenade Launcher M-79 With
Laser Weapon Simulator-Point Kill (LWS-P)

APPENDIX H

SIMULATION SYSTEM FIELD COMMUNICATIONS

SIMULATION SYSTEM FIELD COMMUNICATIONS

During field maneuvers, personnel assigned to the field simulation of indirect fire will be required to monitor appropriate frequencies for the purpose of monitoring commands from the Battalion Fire Direction Centers. They also must communicate with personnel at the simulation net control station (SNCS). The SNCS must be capable of signalling the need to switch receiver frequency.

The anticipated GFE to be used for these field exercises would be the VRC-47 and the PRC Radio Sets. It is felt that the required maneuverability of the field personnel dictates the use of light-weight and less cumbersome radio equipment. The GFE equipment mentioned is considered too bulky for this application, therefore, a search was made for "state-of-the-art" off-the-shelf radio hardware with a lower weight/power ratio to minimize encumbrance of field personnel. From this study, several equipment candidates were found which qualify for the communications hardware. The following equipment, with associated specifications, is recommended as optimum.

The SNCS will be equipped with a mobile/portable transmitter/receiver. This station will also be equipped with encoders and will be used to selectively call any of 25 to 100 mobile/portable receiver decoders. This equipment provides the SNCS operator with the capability of calling, either individually or any number of combinations, for conference calls. The following are the recommended equipments and associated specifications.

- Repco mobile/portable transmitter/receiver (see attached data sheets in Figure H-1); and
- Bramco 225 and 2100A Encoders (see attached data sheets in Figure H-2).

It should be noted that the encoders perform the "paging" function directly through the Repco transceivers.

A best package for field use afoot could be assembled from the Repco modules with the use of primary lithium-cell batteries in lieu of the larger and heavier nickel-cadmium rechargeable batteries. This package could be worn as a back-pack or slung from a belt. A special package of the Repco components with the lighter and smaller

itek/MP **Mobile/Portable** **Transmitter/Receiver**

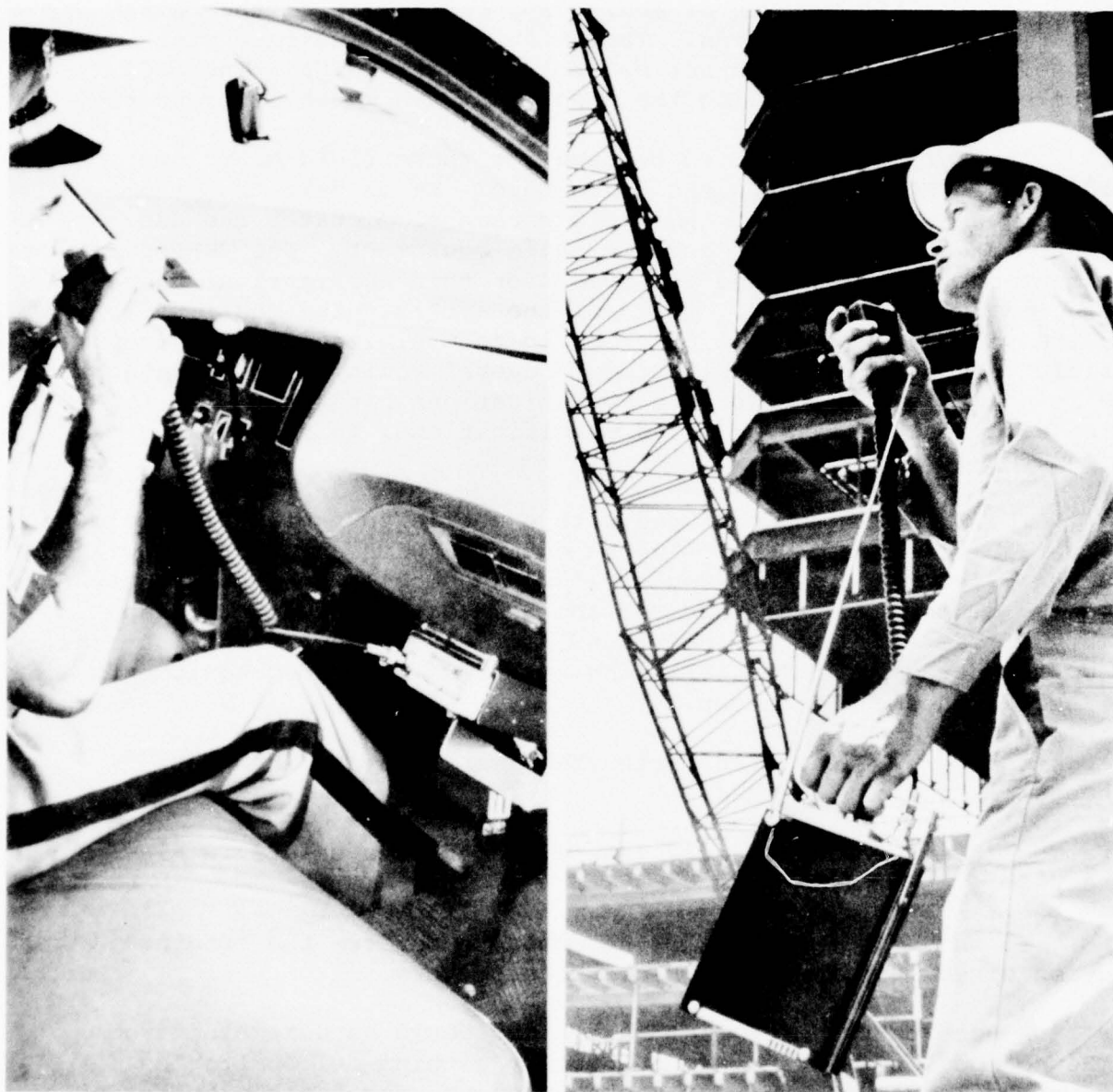

Repro

A subsidiary of SCOPE Incorporated

Figure H-1. Repco Data Sheets (Sheet 1 of 4)

H-4

specifications

| General | 30-50 MHz | 132-174 MHz |
|---------------------------------|--|--|
| Voltage/Power Source (Vehicle) | 13.8 vdc nominal | 13.8 vdc nominal |
| Voltage/Power Source (Portable) | Nickel-Cadmium, 12.5 vdc nominal | Nickel-Cadmium, 12.5 vdc nominal |
| Battery/Life (Portable) | 8 hours Duty Cycle 10% Xmit, 10% Receive, 80% Standby | 8 hours Duty Cycle 10% Xmit, 10% Receive, 80% Standby |
| No. of Channels | 1 thru 5 | 1 thru 5 |
| Frequency | 30 MHz-50 MHz | 132 MHz-174 MHz |
| Dimensions (Portable) | 1.87" x 6.5" x 8.9" = 108.4 cu. inches | 1.87" x 6.5" x 8.9" = 108.4 cu. inches |
| Weight (Portable) | 7 lbs. 3 oz. | 7 lbs. 2 oz. |
| Transmitter | Type accepted under parts: 21, 81, 89, 91, 93. | |
| RF — Output Power (Mobile) | 50 watts | 25 watts |
| RF — Output Power (Portable) | 8 watts | 8 watts |
| Spurious and Harmonics | > 63 db below carrier | > 63 db below carrier |
| Freq. Stability | .002% -30°C to +60°C (25°C Ref) | .0005% -30°C to +60°C (25°C Ref) |
| Modulation | ± 5 KHz deviation at 1 KHz input frequency | ± 5 KHz deviation at 1 KHz input frequency |
| FM Noise | 50 db @ 2/3 system deviation | 50 db @ 2/3 system deviation |
| Emission | 16F3 | 16F3 |
| Receiver | | |
| Selectivity | -80db ± 20 KHz EIA 2 signal method | -80db ± 30 KHz EIA 2 signal method |
| Sensitivity | .35 microvolts 20 db quieting method .25 microvolts EIA 12db SINAD method | .35 microvolts 20 db quieting method .25 microvolts EIA 12db SINAD method |
| Spurious and Image Rejection | -85db below carrier level | -85db below carrier level |
| Freq. Stability | .001% from -30°C to +60°C | .001% from -30°C to +60°C |
| Audio Output Power (Mobile) | 5 watts at less than 10% distortion | 5 watts at less than 10% distortion |
| Audio Power (Portable) | 750 milliwatts at less than 6% distortion | 750 milliwatts at less than 6% distortion |
| Modulation Acceptance | ± 5 KHz deviation at 1 KHz input frequency | ± 5 KHz deviation at 1 KHz input frequency |
| Squelch Sensitivity | .15 microvolts | .15 microvolts |

Base Station Accessory — Specifications and Features

- Available in 120 VAC or 240 VAC 50/60 Hz
- Automatic external antenna connection
- Safety designed interlock switch
- Dimensions - 4 1/2" x 17" x 10" Weight - 26 lbs.
- Four by six inch 5 watt speaker
- Built-in battery charger
- Separate desk mike (810-204-01) also available

Specifications subject to change without notice.

1940 Lockwood Way,
P. O. Box 7065, Orlando, FL 32804
Phone (305) 843-8484
TWX 810-850-0120



A subsidiary of SCOPE Incorporated

Figure H-1. Repco Data Sheets (Sheet 2 of 4)

from mobile to portable instantly

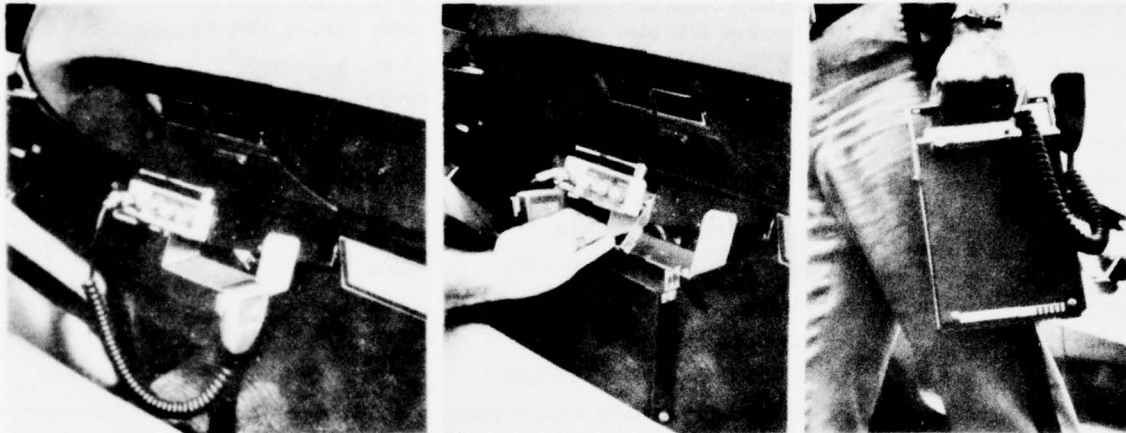

Mobile ...

With the most versatile VHF-FM transmitter-receiver available today, your crew can keep in touch wherever they go, by vehicle or on foot, with the same high performance radio.

As a mobile radio, this mobile/portable powerhouse produces a full twenty-five (132-174 MHz) or fifty watts (32-50 MHz) of RF power. As a portable radio it produces eight watts.

When you pull the handle, the radio instantly and automatically converts from mobile to portable operation.

can the handle...

Portable!

No cables to disconnect, no batteries to connect and no switches to throw. Your mobile/portable will come out of the vehicle as fast as you do ... with no break in communications.

The handle of the portable serves to secure the radio when used as a mobile unit. To return the radio from portable to mobile operation you simply slide your unit into its mounting rack and cam the handle. Instantly you're operating as a mobile radio with twenty-five or fifty watts of RF power.



Actual size

Figure H-1. Repco Data Sheets (Sheet 3 of 4)

compact powerful rugged

A true mobile!

In mobile operation, your radio is powered by the vehicle's battery, producing twenty-five watts of RF power and five watts of audio power through an audio-amplifier-speaker-system permanently mounted in the vehicle.

Miniaturized packaging eliminates the need for trunk, under seat and other cumbersome and expensive installations. The radio is easily installed under the dash, on the transmission tunnel or elsewhere within convenient reach. The equipment comes complete with roof top antenna, hand-held speaker/microphone, mobile 5 watt amplifier-speaker package, mobile mounting rack and installation hardware kit.

With additional mounting racks and antennas, you can equip various vehicles for the use of a single radio. When one vehicle is down for repairs, your radio can be operated in another. An integral lock on the mounting rack protects against unauthorized removal of the radio.

While the radio is operating in the vehicle, its self-contained nickel-cadmium battery is being charged in preparation for portable operation. Protective circuitry automatically prevents overcharging. The unit can even be charged by the vehicle's battery while the ignition is turned off and the vehicle is unattended.

A rugged portable!

The instant you disconnect from your vehicle's power source, you're automatically operating a rugged, light-weight, hand-held portable that produces a full eight watts of RF power. The hand-held speaker/microphone delivers 750 milliwatts of audio power from the receiver.

Just 6 1/2" x 9" x 2" the radio can be operated in any position and the full-swivel, telescopic antenna can always be oriented to the vertical position for maximum efficiency.

The self-contained nickel-cadmium battery provides eight hours of normal operation on a fully charged battery. Although the battery will be maintained in a fully charged condition by planned duty cycles in and out of the vehicle, it can also be recharged by optional AC charging units.

Designed for use in all-weather conditions, the radio has been shock and vibration tested to meet tough military standards for performance and durability, and meets or exceeds all EIA specifications.

Also, a mobile only version with the same outstanding performance characteristics, is available.

Modular construction!

Fourteen P.B.C. modules (plug-in block circuits) have been engineered into this radio to provide the ultimate in solid-state performance, reliability, durability and serviceability. Each sealed module is a completely isolated circuit. If the radio ever stops working, the malfunctioning module can be quickly located and replaced with a fresh module in a matter of minutes. For easy accessibility, all components and P.B.C. modules are fully exposed by removing just four screws and two covers.



Accessories:

- Shoulder Straps
- High Visibility Carrying Bag
- Noise Cancelling Microphone
- Alternate Location Mounting Kits
- Base Station Adapter (Shown Above)
- Battery Chargers - A.C. 120/240 V, 50/60 Hz

Options:

- Time-Out-Timer
- CTCSS Encode/Decode
- CTCSS Encode Only
- Tone Burst 300-3000 Hz
- Up To 5 Channels Tx & Rx
- Multi-Tone Encode Functions
- Dual Channel Scan With Multi Channel Tx

New Model 225 Encoder . . . from Bramco

- Completely Solid-State
- Crystal-Controlled Oscillator
- Attractive, Human-Engineered Package
- Compatible with GE Type 99, Motorola Quik Call II

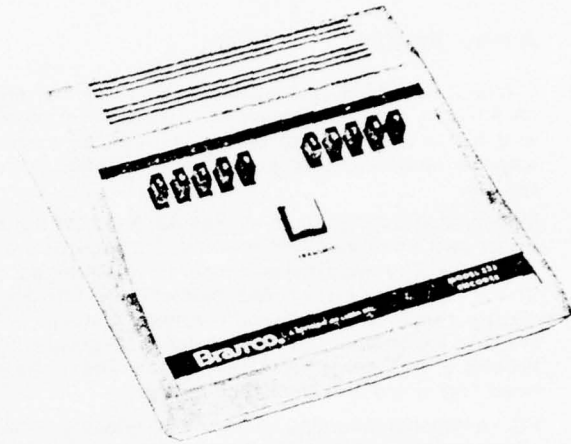

The new Bramco Model 225 Encoder may be used to selectively call any of 25 Mobile 1 Plus 1* decoders. Simply select the two switches corresponding to the vehicle code and press the Transmit button. The signaling tone sequence is then automatically sent with proper timing. A call can be completed in a little over three seconds. Group Call is accomplished by designating specific codes.

The Model 225 Encoder is completely solid-state, uses CMOS IC's and a crystal-controlled oscillator for high stability. The Model 225 provides excellent value for the small system user at an affordable price.

LIST PRICE\$245.00

NOTE: For a 1 Plus 1* Encoder with 100 call capacity see Bulletin 2100A.

DIMENSIONAL DATA

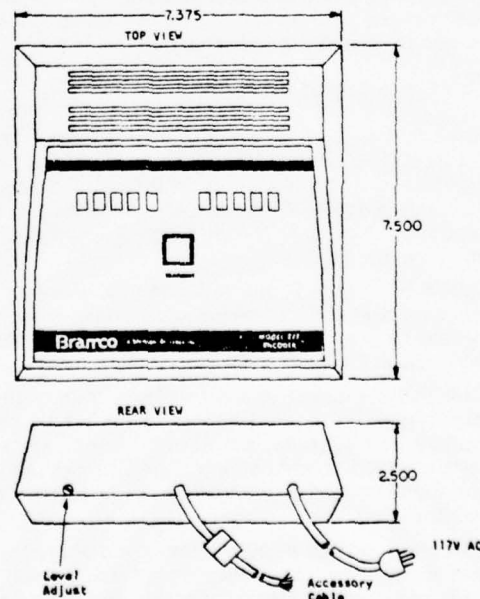

STANDARD SPECIFICATIONS

Signaling Technique: Individual or Group Call; 2 pulses of 1 tone each with a 0.2 second space between pulses. Signaling sequence automatically timed.

Frequency Range: See standard frequency availability information on reverse side.

Frequency Accuracy: $\pm 0.15\%$ of design frequency.

Operating Temperature Range: -30°C to $+60^{\circ}\text{C}$.

Voltage: 0.5 volts RMS minimum into 600 ohm load.

Power Required: 117V AC, $\pm 10\%$, 50/60 Hz or 13.8V DC $\pm 20\%$.

DC Current Drain: 80 mA. idle, 120 mA. operating.

AC Power Consumption: 5 watts.

Bramco.

BRAMCO, A DIVISION OF LEDEX, INC.

1711 Commerce Drive, Piqua, Ohio 45356/513-773-8271

Figure H-2 Bramco Data Sheets (Sheet 1 of 2)

New Model 2100A Encoder...from Bramco

- Completely Solid-State
- Crystal-Controlled Oscillator
- Attractive, Human-Engineered Package
- Compatible with GE Type 99, Motorola Quik Call II

The new Bramco Model 2100A Encoder may be used to selectively call any of 100 Mobile 1 Plus 1[®] decoders. Simply select the two switches corresponding to the vehicle code and press the Transmit button. The signaling tone sequence is then automatically sent with proper timing. A call can be completed in a little over three seconds. Group Call is accomplished by designating specific codes.

The Model 2100A Encoder is completely solid-state, uses CMOS IC's and a crystal-controlled oscillator for high stability. The Model 2100A provides excellent value for the medium size system user at an affordable price.

NOTE: For a 1 Plus 1[®] Encoder with 25 call capacity see Bulletin 225.

STANDARD SPECIFICATIONS

Signaling Technique: Individual or Group Call; 2 pulses of 1 tone each with a 0.2 second space between pulses. Signaling sequence automatically timed.

Frequency Range: See standard frequency availability information on reverse side.

Frequency Accuracy: $\pm 0.15\%$ of design frequency.

Operating Temperature Range: -30°C to $+60^{\circ}\text{C}$.

Voltage: 0.5 volts RMS minimum into 600 ohm load.

Power Required: 117V AC, $\pm 10\%$, 50/60 Hz or 13.8V DC $\pm 20\%$.

DC Current Drain: 80 mA. idle, 120 mA. operating.

AC Power Consumption: 5 watts.

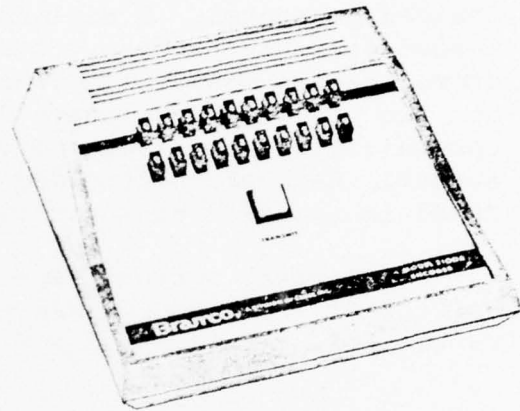

LIST PRICE\$395.00

DIMENSIONAL DATA

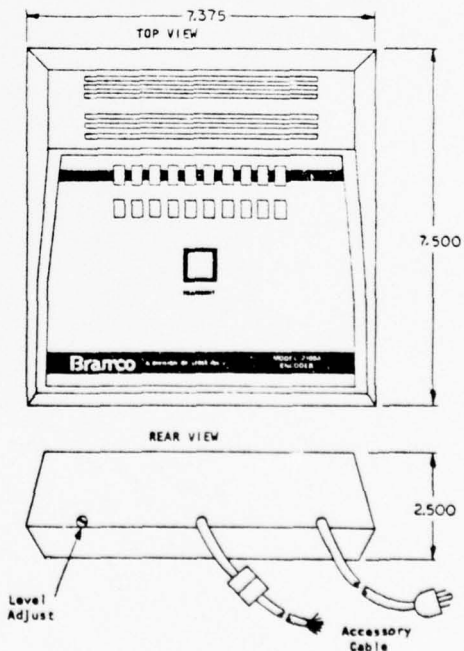

Bramco

BRAMCO, A DIVISION OF LEDEX, INC.
1711 Commerce Drive, Piqua, Ohio 45356/513-773-8271

Figure H-2 Bramco Data Sheets (Sheet 2 of 2)

primary lithium-cell batteries, canvas back-pack, and speaker/microphone/antenna assembly (817-098-01) is recommended as the best approach for field use. The use of several of the Bramco model 225 encoders, working through Repco transceivers at the SNCS to page the fielded personnel, is feasible. This equipment use would involve the transceivers working on the frequency of the fire direction center (FDC) nets normally being monitored by fielded personnel. A minimum of two such transceivers would be needed for this purpose, together with a Bramco encoder at each communication position in the SNCS. This amounts to 12 encoders and two paging transmitters for the SNCS, in addition to the normal communications sets for voice communication with the fielded personnel. Each of the fielded personnel will carry the recommended Repco transceiver as specially packaged for this purpose.

Crystal options, specifications and representative circuits for the Bramco encoders are provided in the data sheets shown in Figure H-3.

SEQUENTIAL TONE DECODER, OPTION 810-249-01

The sequential tone decoder provides selective call for any radio so equipped and will respond only to the proper two tones in the correct sequence. This allows the operator a choice of hearing other activity on the channel frequency or to hear only the appropriately coded signals. The operational mode is determined by a switching function which occurs when the microphone is removed from its hang-up bracket. When the button on the back of the microphone is grounded (at rest in its hang-up bracket) the tone decoder circuits are active. Removing the microphone from its hang-up bracket deactivates the tone circuits and permits other transmission activity to be observed. The noise squelch is properly adjusted by advancing the squelch control to the point where receiver noise disappears after having removed the microphone from its hang-up bracket and while the frequency channel is free of transmitted signals.

The sequential tone decoder (810-249-01) is activated by the reception of two tones in the proper sequence. Although timing is not critical, a tone format of one second ON for tone A followed by three seconds of tone B is recommended. This provides compatibility with the Bramco "1 + 1" system.

The tone gate holds the receiver in a squelched condition until a carrier is received with two tones of the proper frequency and sequence. The demodulated tone is fed to amplifier Q1 through C4 to reed #1. The combination of reed Q4-Q5 is a bistable multivibrator circuit. Initially Q4 is conducting, thus grounding the bottom of reed #1 primary. If tone #1 falls within the $\pm 0.5\%$ bandwidth of reed #1, the tone is applied to Q2. The output of Q2 is coupled through C6 to CR1, CR2 and C20 where the resultant positive voltage is applied to the base of Q5 causing it to conduct. This causes Q4 to cut off, thus ungrounding the primary of reed #1 and grounding the primary of reed #2.

If a tone of proper frequency is then fed through Q1 to C3 and reed #2, a tone output will be applied through C8 to Q3, where it is amplified. The amplified tone is fed through C9 to filter CR3, CR4 and C10, and the resultant positive voltage is applied to the base of Q7 through CR10. This causes Q7, initially cut off, to conduct, thereby turning off gate Q8 and subsequently unsquelching the receiver and turning on the audio module. The receiver will remain unsquelched as long as a carrier is present, even though the second tone may no longer be present.

When the carrier disappears, a positive voltage is fed from the squelch module to CR11. This causes the base of Q4 to go positive and resets Q4 to the conducting state. Also, the action of Q5 turning off causes a positive voltage to develop at its collector. The positive voltage is fed through CR8 to the base of Q6 thus turning Q6 on and Q7 off. This turns Q8 on and squelches the receiver. With Q4 and Q6 conducting, the tone assembly is reset and conditioned to detect tone #1.

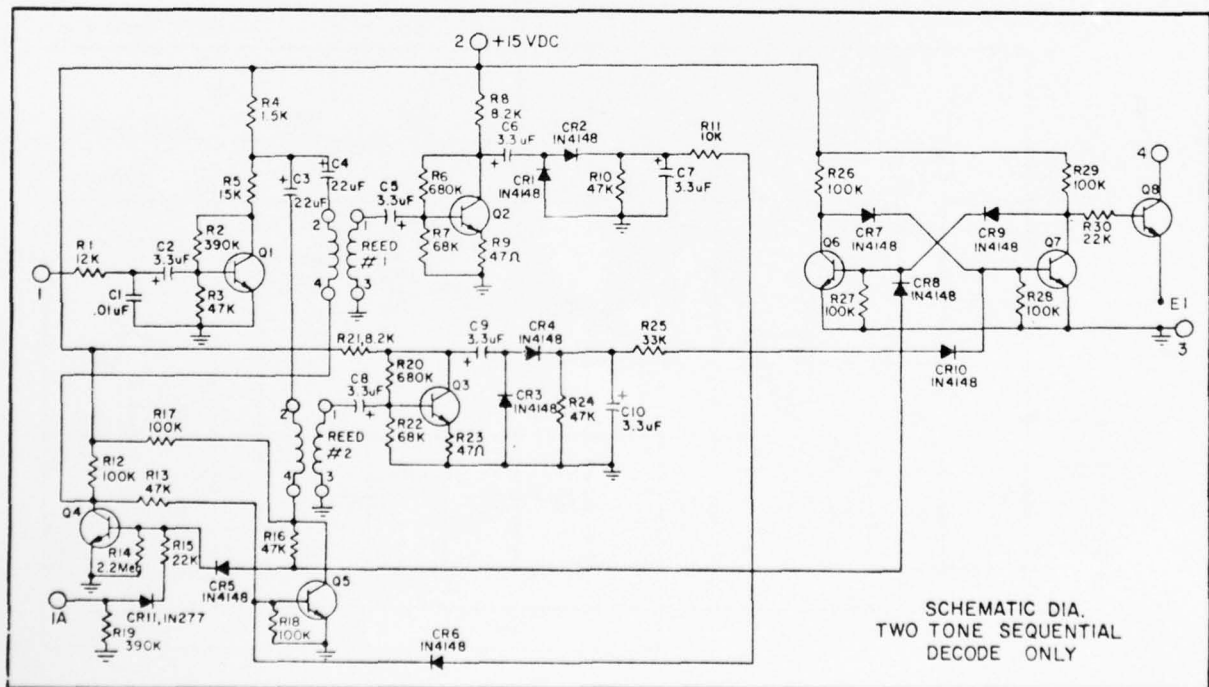

Figure H-3 Bramco Data Sheets (Sheet 1 of 4)

TONE BURST ENCODER OPTION, 810-248-03

The Tone Burst Encoder ("C" Option) adapts the Packset to radio systems utilizing receiving equipment which is activated by a timed tone code. In the tone burst system a single tone is transmitted for 300 milliseconds when the push-to-talk switch is depressed. The tone signal unsculches the receiver and permits the transmission to be heard. The tone burst circuit operates in an audible range of 1000 to 3000 Hz and utilizes a resonant reed (45-03-003) for generating the tone signal. The resonant reed has a response time of 25 milliseconds nominal to -6 dB voltage level and a decay time of 800 milliseconds nominal to -12 dB voltage level.

The tone burst circuit operates as follows: When the PTT switch is depressed, point 2A becomes positive and this voltage is applied to the base of Q4 causing it to conduct and thus complete the feedback loop to the base of Q1 which initiates oscillation. The output load is held constant by the AGC circuit C9, CR1, CR2, C12, R18, R19 and Q5. The tone signal is turned off by gate transistor Q2. When point 2A is made positive, C5 is charged through R8 and caused Q2 to conduct when the base to emitter voltage reaches approximately 0.7 volt. This turns off Q3 and stops the oscillation. The time interval is determined by C5 and R8. R9 discharges C5 when the PTT switch is released and thus prepares the circuit for the next operational cycle.

Circuitry for the option (810-021-01) is contained on a P. C. Board equipped with pin-plug which mate with sockets located on the lower section of the Main P. C. Board. The 21-05-002 sockets (Item 1) are installed in six positions as shown for 810-248-01 (-02) on a preceding page. The sockets and area utilized also accommodate other optional tone systems and thus restricts the choice of tone options to a singular system.

With the proper reed plugged in and the Tone P. C. Board mated with the radio, the system operates automatically without further adjustments other than setting deviation limits. The reed is secured with 510-310-02 hold-down clip (Item 2), 2-56 x 3/16" screw (Item 3) and washer (Item 4). A 2-56 x 3/8" screw (Item 5) is installed from the module side of the radio's Main P. C. Board (beneath module 6) to engage the threaded stud on the Tone Board and thus to anchor it into position.

The Tone Burst deviation adjustment is properly made as follows: Verify that the Packset's voice deviation is correctly set (see transmitter alignment section), actuate the push-to-talk switch and set R13 to 3000-4000 Hz deviation as observed on a deviation monitor connected to the attenuated output of an in-line watt meter terminated into a 50 ohm load. The base of Q2 should be shorted to ground during the adjustments. A schematic for the option is shown below.

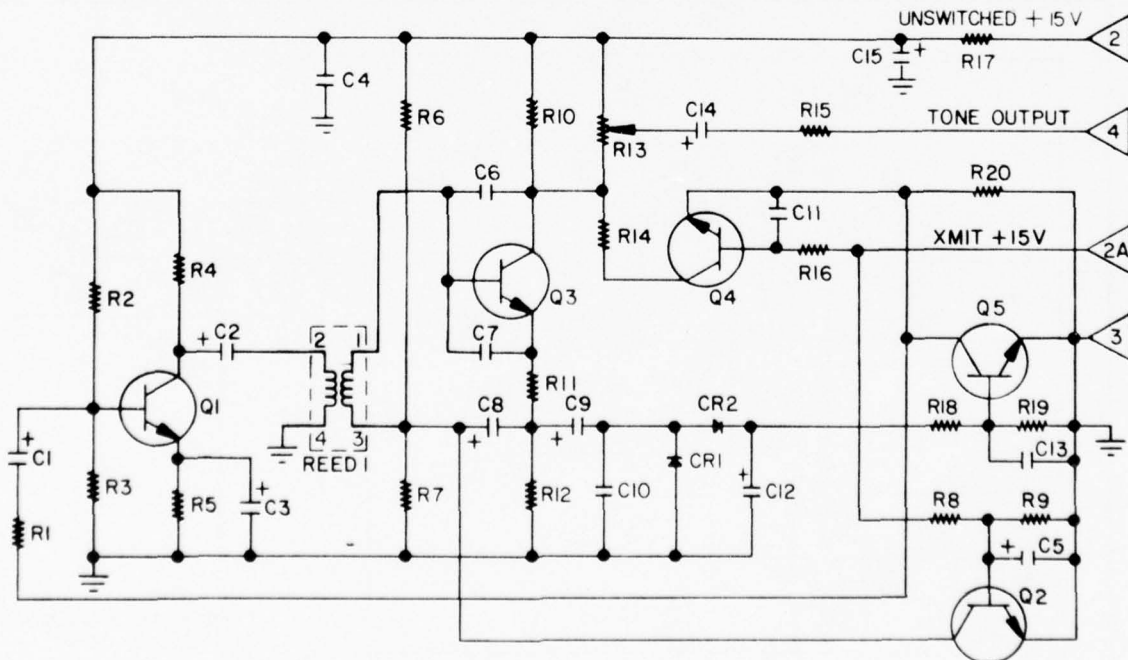

Figure H-3 Bramco Data Sheets (Sheet 2 of 4)

CRYSTAL SPECIFICATIONS

The quartz crystal units furnished with your transceiver represent the highest quality obtainable. The crystals are aged and then tested over a range of temperatures to assure that a precise stability characteristic exists to permit exacting circuit compensation. The factory's quality assurance program requires continuing tests to verify that specification compliance is maintained. THE EQUIPMENT SPECIFICATIONS INVOLVING FREQUENCY STABILITY ARE ASSURED ONLY IF CRYSTALS SUPPLIED BY THE MANUFACTURER (OR CRYSTALS FURNISHED BY MANUFACTURER APPROVED SUPPLIERS) ARE ADDED OR REPLACED IN THE FIELD.

23-10-006 TRANSMITTER CRYSTAL - 66-88, 132-174 MHz (Y1-Y5)

Military type CR-78/U (parallel resonant) except:

Case: HC-25/U except pin length of .187 ±.010 inch

Frequency: 7.333333 to 9.777777 MHz (Calculate as follows to six decimal places)

$$66-88 \text{ MHz, Crystal Frequency} = \frac{\text{Operating Frequency}}{9}$$

$$132-174 \text{ MHz, Crystal Frequency} = \frac{\text{Operating Frequency}}{18}$$

Load Capacity: 20 pF

Frequency Tolerance at 25°C: ±.001%

23-10-007 RECEIVER FIRST OSCILLATOR CRYSTAL - 132-174 MHz (Y6-Y10)

Military type CR-77/U (series resonant) except:

Case: HC-25/U except pin length of .187 ±.010 inch

Frequency: 38.350000 to 54.433333 MHz (Calculate as follows to six decimal places)

$$66-88 \text{ MHz, Crystal Frequency} = \frac{\text{Operating Frequency} + 10.7 \text{ MHz}}{2}$$

$$132-150.8 \text{ MHz, Crystal Frequency} = \frac{\text{Operating Frequency} + 10.7 \text{ MHz}}{3}$$

$$150.8-174 \text{ MHz, Crystal Frequency} = \frac{\text{Operating Frequency} - 10.7 \text{ MHz}}{3}$$

Dissipation: 1 milliwatt maximum

Frequency Tolerance at 25°C: ±.001%

23-09-002 RECEIVER SECOND OSCILLATOR CRYSTAL (Y11)

Military type CR-77/U (parallel resonant) except:

Case: HC-25/U except pin length of .187 ±.010 inch

Frequency: 10.245 MHz ±.002% at +25°C

Load Capacity: 68 pF

NOTE: Some radio models utilize receiver second oscillator crystals with frequency specifications of 10.243 MHz (23-09-005, coded blue) or 10.247 MHz (23-09-004, coded orange). In these cases the IF filters (Z1) have compatible band pass characteristics and are provided with a matching color code.

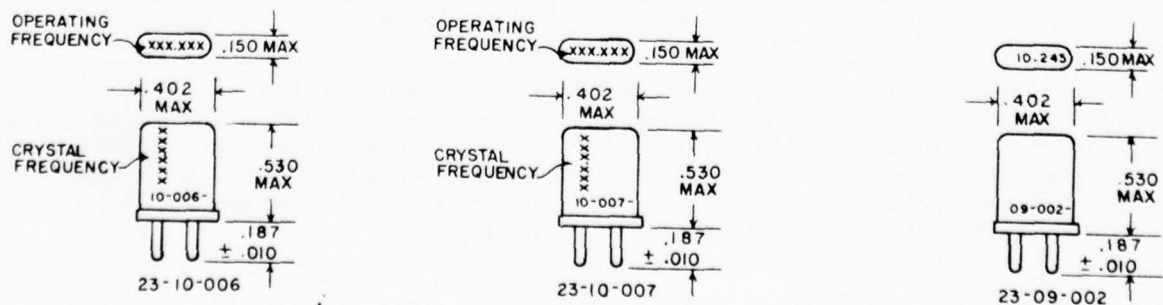

Figure H-3 Bramco Data Sheets (Sheet 3 of 4)
H-13

MULTI-TONE BURST OPTION, 810-251-xx

The Tone Burst Encoder (01, 02, 03, 04 and 05 options) adapts the handheld transceiver to radio systems utilizing Tone Burst Decoders which are activated by a tuned tone impulse. Five basic configurations are available which provide from one to five individual tones and thus compatibility with receivers having private channel or selective signalling requirements. A tone "OFF" position is included on the tone selector switch thus providing the capability to address receivers which are not equipped with tone sensing circuitry while excluding those so equipped. In the Tone Burst described here a single tone is transmitted for a specified period when the push-to-talk switch is activated. This tone signal unselects a remote receiver (s) allowing the subsequent transmission to be heard. The Tone Burst operates in the frequency range of 1800-2552 Hz. However, other frequencies between 60-3500 Hz are available on special order. The actual frequency depends on the tone module utilized.

The burst tone nominally reaches 50% of the output level (-6 dB) within a period of 25 milliseconds and decays to -12 dB in 80 milliseconds. This total period is variable over the range 100 milliseconds to 2 seconds by changing the value of components C1 or R2. The Tone Module (918-181-01) contains the oscillator and the main frequency determining components for the range 1800-2552 Hz. Each of the five tone frequencies are provided with an external setting potentiometer which is switched into circuit as required. Stability is within $\pm 0.5\%$ over the range -30°C to $+60^{\circ}\text{C}$ and battery voltages of 9-16 VDC. Current drain is normally less than 1 mA at 16 VDC.

Circuitry for the Multi-Tone Burst Option is contained on printed circuit board 710-216-xx which is equipped with three pin-plugs that mate with sockets centrally located on the circuitry side (opposite module side) of the radio's Main P.C. Board. A threaded stand-off bushing is provided which serves as an anchor point. The anchoring screw is accessible after removing the number 6 module. The tone module has four pin-plugs that mate with appropriate sockets on the 710-216-xx P.C. Board. Special versions may include one or two additional sets of sockets for other tone modules covering other frequency segments.

After the Multi-Tone Burst circuit has been installed and adjustments made, operation is entirely automatic. When adjusting the Tone Burst Option, two procedures are required. (1) Tune the individual tones to mesh with selected receiver tones. For each active position of the tone switch the related potentiometer (R21 thru R25) is adjusted (with PTT switch activated) to the proper tone frequency while observing an electronic frequency counter. (2) Set tone amplitude. This is accomplished by activating the PTT switch and then adjusting R13 to 3000-4000 Hz deviation as observed on a deviation monitor connected to the attenuated output of an in-line watt meter terminated into a 50 ohm load. The base of Q2 should be shorted to ground during the later adjustment.

| <u>OPTION IDENTIFICATION AND DESCRIPTION</u> | | | | |
|--|-------------|----------------|----------------------|--------------------------------|
| Option Code | Part Number | Tones Provided | P. C. Board Utilized | Tone Adjustment Potentiometers |
| 01 | 810-251-01 | One | 710-216-02 | R21 |
| 02 | 810-251-02 | Two | 710-216-03 | R21, R22 |
| 03 | 810-251-03 | Three | 710-216-04 | R21-R23 |
| 04 | 810-251-04 | Four | 710-216-05 | R21-R24 |
| 05 | 810-251-05 | Five | 710-216-06 | R21-R25 |

NOTE: Stop-pins are used in the front casing of the tone switch to limit its rotation to the specified number of tones provided. The extreme CCW position is utilized as the OFF position. R21 thru R25 (on P.C. Board 710-216-xx) permit the various tones to be set within the range of 1800-2552 Hz when using the standard 918-181-01 tone module. Other special tone modules are available for frequency segments in the 60 to 3500 Hz range. The tone modules utilize solid state circuitry and measure .525 x .90 x .38 high.

SYSTEM LOGISTICS

LASER WEAPON SIMULATOR SYSTEM

A. INTRODUCTION

This appendix describes the methods and procedures followed to determine the logistics resources necessary to support the employment of the Laser Weapon Simulator System in the simulation of indirect fire. Section IV of the final report includes comparative summations of the logistics resource requirements for all alternate systems considered during this study.

B. PERSONNEL REQUIRED

From review of the overall problem of simulating indirect fire, it was apparent that some form of central control would be necessary to control and coordinate the activity of the laser weapon simulator operator(s) in the field.

An initial approach was to investigate the feasibility of placing simulation team personnel in parallel at each of the mortar battery fire direction centers (FDCs), monitor the fire requests and retransmit the data to a central control station, who in turn would relay appropriate data to the field operator. This method was rejected as a redundancy of effort, and was not in keeping with a desired goal of minimizing the number of simulation team personnel in proximity to the maneuver forces.

Also rejected was the approach proposing a separate central control station for each maneuver force in each respective area. This method resulted in duplication of communications equipment and support resources and did not give either station control of all the operators in the field.

The concept of one central control station was therefore adopted and is referred to as the Simulation Net Control Station (SNCS), with all monitoring functions performed in this area. The following task descriptions and job titles were arrived at to perform the required functions of the SNCS.

- Field Artillery Simulator

This person will monitor and respond to all normal artillery fire requests generated during the maneuver exercise. To the maneuver force, he will be the supporting field artillery FDC and/or batteries. He will control the action of field personnel by transmission of impact coordinates and weapons data. He will have the facilities to monitor and respond to all normal FDC/battery loops and to command and communicate with field personnel. He will act in concert with the SNCS commander in the performance of his responsibilities pertaining to operational constraints placed on the maneuver forces. One such position for each maneuver force is required.

- Computer, Field Artillery Simulator

This person will assist the Field Artillery Simulator in the performance of his tasks. Because of the need for the Field Artillery Simulator to actively participate in maneuver force requests and/or decisions, this position is considered necessary. He will maintain required records of fire missions, current ammunition inventories and compute all impact coordinates for transmission to the field personnel. He will require no transmission capabilities to the maneuver force - FDC loop, but will be able to monitor such transmissions. When directed, he will transmit data to field personnel in those situations where the Field Artillery Simulator is otherwise occupied. One such position for each maneuver force is required.

- 4.2-Inch Mortar Simulator

This person will monitor all messages between the fire requesting source and the actual 4.2-inch Mortar FDC. He will convert all fire requests to grid coordinates. He will maintain required records of fire missions and current ammunition inventories. He will have decision making authority for assignment of field personnel to simulate the effects of 4.2-inch Mortar fire. He will have the facilities to command and communicate with field personnel and will transmit impact coordinates and weapons data to field personnel. One such position is required for each maneuver element.

- 81-mm Mortar Simulator

This person will monitor all messages between the fire requesting source and the actual rifle company FDC. He will convert all fire requests to grid coordinates. He will maintain required records of fire missions and current ammunition inventories. He will have decision making authority for assignment of field personnel to simulate the effects of 81-mm Mortar fire. He will have the facilities to command and communicate with field personnel and will transmit impact coordinates and weapon data to field personnel. Three such positions (one per company) is required for each maneuver force.

- Maneuver Display Operator

This person will reposition symbols representing maneuver force elements and simulation team members, forward observer (FO) locations, and the like on a tactical data display board. He will be positioned so he has direct contact with the TDDB and will reposition the symbols in accordance with information relayed by field personnel. He will monitor and respond to all field operator originated calls. Requests for field operator originated repositioning will be coordinated with SNCS commander prior to approval.

- SNCS Commander

This person has overall responsibility for the conduct of the simulation effort during the exercise. He will assure compliance by the maneuver forces with all constraints placed on the maneuver forces via pre-exercise briefings or operational plans -- that is, simulated repositioning of field artillery batteries after a pre-determined number of rounds/time of firing with a resultant decreased fire power for the period of the repositioning; deactivation of specific batteries after ammunition consumption for a time commensurate with nominal resupply times; and the destruction of appropriate field artillery batteries in those cases where positions have been compromised to the extent that opposite force artillery would theoretically destroy it.

As a side effect of the determination of specific functions to be performed in the SNCS, a need for a device to pictorially display the maneuver area field personnel and maneuver element positioning became apparent. Suggestions for implementation are provided in Appendix H.

Attention then turned to determination of the number of field personnel required to perform the simulation of indirect fire using the laser weapon simulator. Because an audio/visual cue (flash-bang) device must be detonated in the impact area and the range of considered devices was considerably less than that of the laser weapon simulator, it became necessary to separate the tasks of providing the visual cue and operating the laser weapon simulator. Separate personnel are therefore required for each task.

Due to the variables involved in the problem, the number of field personnel required to perform the simulation of indirect fire cannot be precisely determined. The proposed numbers were arrived at by taking a tactical exercise and simulating the positioning of field personnel to cover the exercise.

The exercise used was an extract from "Tactical Operations Handbook", prepared by the United States Army Infantry School, at Fort Benning, Georgia. See annex 1 to this appendix for the pertinent extracts from the exercise narrative and situation map showing initial positioning of laser scanner operators. As a result of this study a required number of five laser weapon simulator operators per maneuver battalion was arrived at as a suggested minimum. This number might vary, depending upon maneuver area terrain and foliage cover, rapidity of maneuver element movements, weather and amount of fire to be simulated.

Due to the aforementioned range of the visual cue device, it is proposed three visual cue operators be provided for each two laser scanning device operators. This number is based upon the belief that these operators will be required to change positions more frequently than the laser scanning device operators. Eight visual cue operators are proposed per maneuver battalion.

It is not likely that one group will be physically capable of performing throughout an exercise which may last 96 hours. These proposed numbers must be multiplied by three for eight hour shifts or by two for twelve hour shifts to provide relief for the simulation team personnel.

Total simulation team personnel required are:

| | | | |
|--------------------------------|-----------|-----------|------------|
| System Control Center | 15 | 30 | 45 |
| Laser Scanning Device Operator | 10 | 20 | 30 |
| Visual Cue Operator | 16 | 32 | 48 |
| Smoke Generator Personnel | 8 | 16 ① | 24 ② |
| | <u>49</u> | <u>98</u> | <u>147</u> |

① 12 hour shifts

② 8 hour shifts

Task descriptions for the Laser Weapon Simulator (LWS) operator and the Visual/Audio Cue Operator (VACO) follow:

- Laser Weapon Simulator Operator (LWS)

Determines position by use of an observer's sextant and specially programmed calculator. Monitors fire authorization/request net of appropriate maneuver force to anticipate his positioning requirements. Communicates with the Simulation NCS when commanded by pager device or when required to furnish maneuver force positioning information. Sets appropriate controls on LWS from information received from Simulation NCS and determines range and bearing of "impact point" by use of the specially programmed calculator. Coordinates operation of the LWS with actions of VACO.

- Visual/Audio Cue Operator (VACO)

Determines position by use of an observer's sextant and a specially programmed calculator. Monitors fire authorization/request net of appropriate maneuver force to anticipate his positioning requirements. Communicates with the Simulation NCS when commanded by pager device or when required to furnish maneuver force positioning information. Fires visual/audio cue device in coordination with actions of LWS operator over "impact point" determined by use of the specially programmed computer. Records "impact point" observations in accordance with pre-operational briefing instructions.

● Smoke Generating Team

Determines position by use of an observer's sextant and specially programmed calculator. Dispenses smoke (see paragraph D in Section IV of the final report for recommendation) to cover selected area via data received from NSCS. Coordinates activities with those of the LWS and VACO as required. To lay the smoke in as expeditiously as possible, a vehicle driver and smoke dispenser comprise the team.

NOTE 1: As the proposed concept for the simulation of indirect-fire does not require the presence of an actual artillery unit, consideration should be given to manning the fire support officer (FSO) position at each maneuver battalion with a field artillery qualified member of the simulation team. This will simulate actual conditions and free the heavy mortar platoon leader for the performance of his normal tasks.

NOTE 2: Although not itemized as direct support personnel, normal Army support requirements will dictate the number of personnel required to supply the simulation team with food service and minimal vehicle and communications equipment repair during the period of the exercise.

C. OPERATIONAL SCENARIO

Operational employment required personnel is described in the following paragraphs.

A call for fire is received by the field artillery simulator in the SNCS. As he responds, according to standard procedures, his conversation is monitored by his computer. His computer plots the theoretical impact coordinates of the round(s) while the field artillery simulator is handling the standard communications procedures.

By observation of the tactical data display board, an appropriately positioned LWS operator and VACO are selected to cover the event. Their respective discrete address code is transmitted and received by the pager device that each field operator carries. This command directs the paged operators to return to a predetermined frequency, which connects them to the SNCS communication net.

Assuming approval of the fire mission, the impact coordinates are transmitted as part of an "event message", which also includes LWS settings and number/duration of laser transmissions/visual cue firings required to simulate the fire mission. This decision of "how" to simulate the desired fire mission made by SNCS is determined by referral to standard operating procedures (SOPs) generated prior to the exercise.

The field operators then determine azimuth and range to the impact point by use of the hand-held calculator and observer's sextant. Their precise geographic position had been determined prior to this time by use of the same equipment.

The appropriate controls are set on the LWS, the device oriented to the proper direction and the mission is simulated by triggering the LWS and the visual all device. Coordination required between the LWS operator and VACO is conducted via the common communication link. The operators record required data on forms provided and leave the SNCS communication net to resume monitoring maneuver force frequencies to anticipate repositioning requirements for future fire missions. A time line of these operations versus typical operational times is shown in Figure I-1.

Although all operational contingencies have not been envisioned at this time, one does appear worthy of mention at this point. It is highly conceivable that the impact point and target personnel might be in such a position (densely wooded area) that a scanning laser could not penetrate the position and illuminate the target area. Future consideration should therefore be given to equipping the VACO with a MILES umpire weapon (controller gun) which would enable him to physically enter the area and disable an appropriate amount of vehicles/personnel, as directed by SNCS, by direct fire.

Additional considerations concerning LWS operator positioning and the simulation of Cannon Launched Guided Projectile (CLGP) is included in the following paragraphs.

D. LASER OPERATION ON THE GUN-TARGET LINE

It has been suggested that in hilly terrain, the lasers should operate on the gun-target line. This is a problem in actual use of artillery. Especially with the long-range howitzers firing in low trajectories, the problem of attaining

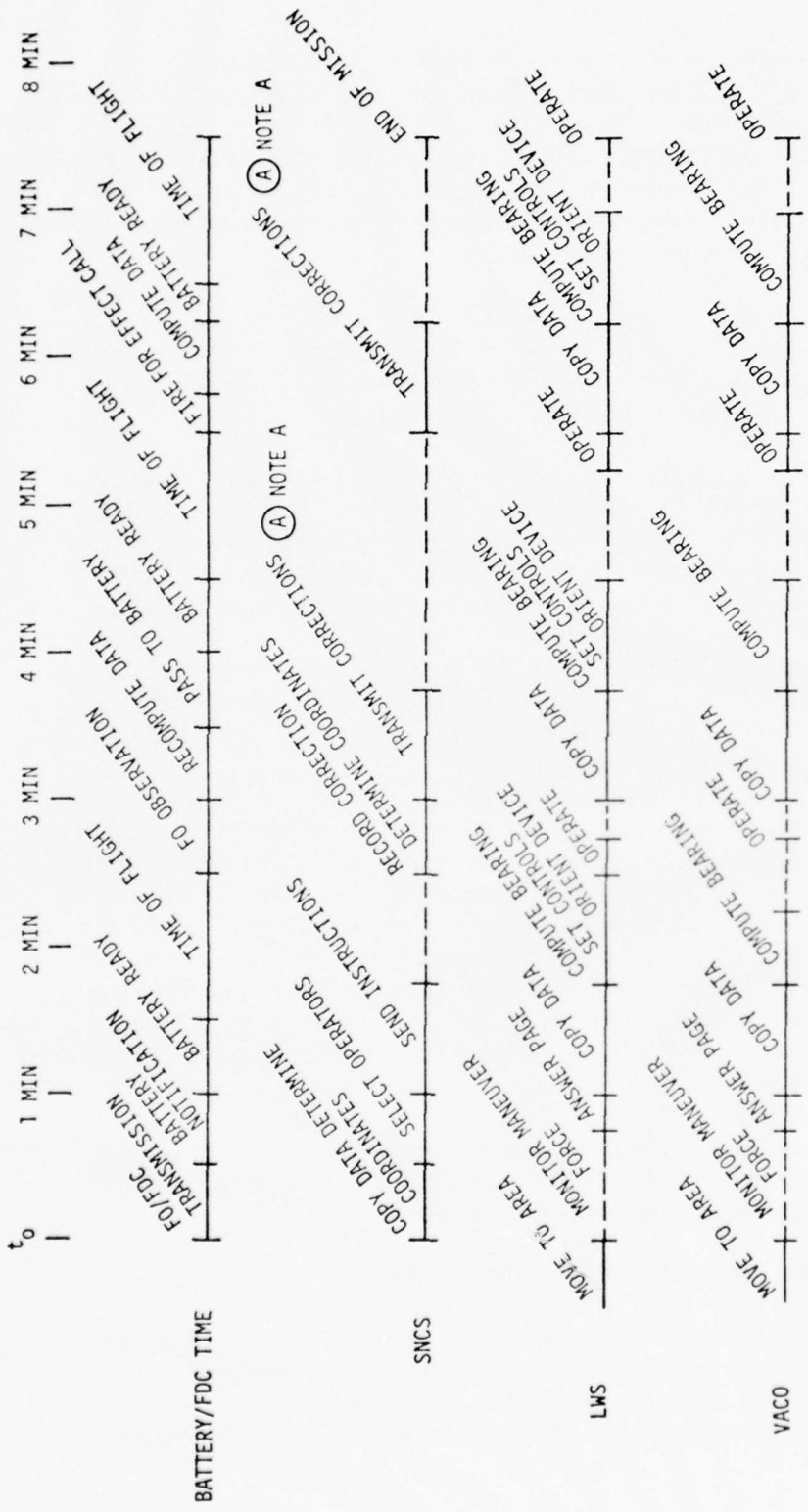

1. LWS AND VACO ASSUMED IN POSITION AT TO BY VIRTUE OF PREPLANNING, SNCS DIRECTIONS, DATA FROM MONITORED TRANSMISSIONS AND THE LIKE.
 2. BATTERY AND FDC OPERATING TIMES EXTRACTED FROM LEVEL 1 REQUIREMENTS OF ARTEP 6-365. TIME OF FLIGHT ESTIMATED 1 MINUTE.
- (A) SOP'S WILL DICTATE NEED FOR RECOMPUTING AZIMUTH/RANGE FOR SUBSEQUENT ROUNDS BASED ON MINIMUM CORRECTION CRITERIA.

P3203

Figure I-1. Typical Battery Fire Mission: "Battery Adjust, 2 Rounds"

accuracy on the far, downhill slopes is severe and oftentimes impractical, because the slopes can exceed the angle of the trajectory. When this condition occurs, the only choice is to fire in high trajectories. Even then, accuracy will suffer somewhat because of the slopes. The high trajectory mortars are seldom troubled by inaccessible targets on slopes. However, some loss of accuracy is inevitable.

In laser simulation of artillery fire, the users of the lasers must necessarily take an advantageous position, generally higher than the targeted troops and vehicles, whenever feasible. This position is desired to obtain the very useful depression-angle of the laser scan pattern for control of the depth of the scanned area simulating the effective area of the incident being simulated. The problems encountered by real artillery because of slopes may be considered as irrelevant to the problems of simulating this condition. If it is desired to introduce the error-effect of slopes, this condition can be introduced at the net control station by calling the simulation at a point biased from the intended location. The point does seem relatively unimportant, however, in view of the need for advantageous positioning of laser transmitters for good area simulation.

It must be brought out that the advantageous use of terrain in actual warfare can be decisive. The requirements are often at odds, however. Generally speaking, the use of defilade and screening by vegetation, and the like is an essential factor in avoidance of direct fires for tanks, APCs, and the like. Typically, in much of Europe, it will be very seldom that direct fires will be feasible beyond about 1 km, simply because such vehicles will take every advantage of defilade and screening. The location of direct-fire weapons such as TOW on forward slopes modifies this considerably, but it exposes such positions to direct counterfire.

Fire of such weapons as TOW from within the edges of the forests typically found near the crests of European hills is feasible, but such areas are usually brought under precautionary machine-gun fire by advancing tanks and fire of a TOW should expect immediate response of heavy machine-gun counter-fire, possibly followed by direct cannon fire. Indirect-fires can be very useful in such situations to force tanks to button up, thus greatly reducing the vision of the tank crews and improving the probability of success of antitank direct-fire weapons.

E. CANNON-LAUNCHED GUIDED PROJECTILE

The Cannon-Launched Guided Projectile (CLGP) is a "horse of a different color". It is an indirect-fire weapon with the target-accuracy of a direct-fire weapon, or better. It can destroy tanks moving at high speed.

The critical point in CLGP operation is that an observer equipped with a laser designator must maintain his laser beam accurately on the tank target during the terminal portion of the CLGP trajectory. This operation should be simulated, because it is likely to be the most effective means of attrition of an enemy tank force.

There are a number of schemes for accomplishing this operation with narrow-beam gallium arsenide (GaAs) lasers. The tanks will be equipped with a "belt" of MILES detectors. It is necessary that the GaAs beam be sufficiently large to span the space between at least two of these simultaneously so that at least one is illuminated (that is, a small beam could "land" between the detectors). Therefore, duplication of the size of the extremely narrow neodymium-doped, yttrium-aluminum-garnet (Nd:YAG) laser beam is not desirable.

The CLGP laser simulator should be a replica of the actual laser designator device, but project a wider GaAs beam. Coordination of the simulated CLGP firing and target illumination should be done in the exact fashion that the real CLGP procedures accomplish. The operator has only an approximate idea of the time of impact of the CLGP, so he must illuminate the target with the designator (real) for an appreciable time. To simulate this action, the GaAs laser CLGP simulator should be equipped with an RF receiver. This, upon receipt of a coded signal from the SNCS at the simulated time-of-impact, would actually switch the laser to the transmit mode for about a second. The code transmitted should be one giving a high tank-kill probability in the tank's MILES equipment. The laser operator should be notified with an audible signal from the simulator that the mission is completed. Figure I-2 is a block diagram showing the CLGP simulator.

F. TRAINING REQUIRED

All field personnel will require organizational level training in the use of the observer's sextant and associated specially programmed calculator. Formal training should be minimal because of the simplicity of the devices. The emphasis on training should be in actual use of the devices under the field conditions likely to be encountered.

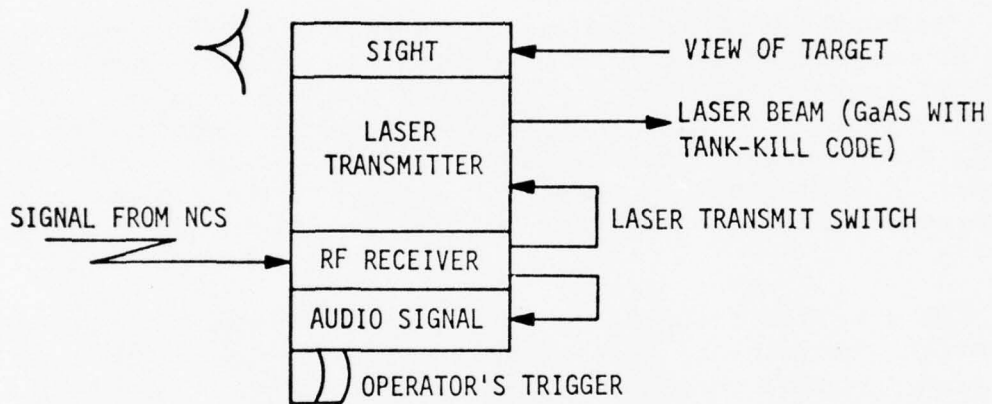

NOTE: ENTIRE DEVICE SHOULD BE A REPLICA OF CLGP TARGET DESIGNATOR. THE LASER TRANSMITTER CAN BE A STANDARD MILES DIRECT-FIRE TYPE. TRANSMITTING A CODE CAPABLE OF SIGNIFYING TANK/APC KILL.

P3217

Figure I-2. CLGP Simulator Block Diagram

Laser Weapon Simulator operators will require organizational training in the use and field level maintenance of the device. No extensive training requirements are anticipated. The device is simple to operate and anticipated field level maintenance will consist only of replacing a quick-access battery pack upon depletion. Heavy emphasis should be placed on actual operation of the device under the field conditions likely to be encountered. In addition, SOPs should be generated to govern the actions of the operator under the myriad of fire simulation situations he will encounter.

Personnel who man the mortar battery simulation positions in the proposed SNCS should be proficient in determination of geographic coordinates from any of the forms the fire request may take -- that is, shift from known point, gridded thrust line or polar coordinates. Organizational level training for these personnel is suggested. Because the field artillery simulator must be an artillery officer, no specialized training is anticipated.

No specific training is anticipated for the visual/audio cue operator because the adopted device is anticipated to be fired from a weapon currently in the Army inventory. However, because of the safety factors involved, strong emphasis must be placed on developing operator awareness of the safety procedures to be observed.

Because of the coordination required between all members of the simulation group, extensive dry-run exercises will be required prior to actual participation in initial maneuver exercised.

Once a basic cadre of simulation team members is established, replacements, which will no doubt be required, can be trained largely by "pairing" with experienced personnel in field exercises.

G. GENERAL PLAN

Personnel assigned to the SNCS will monitor appropriate maneuver force frequencies to obtain the information necessary to simulate the various mortar firing batteries. Field artillery

battery simulators will be in direct communication with the respective maneuver forces and will make all responses/decisions normally performed by the Artillery Battalion FDC and batteries.¹

Field personnel will be provided the capability to monitor maneuver force frequencies while maintaining a mobile posture and be capable of communicating with personnel in the SNCS when commanded by a pager device.

H. COMMUNICATIONS

To properly perform their tasks, personnel in the proposed SNCS must receive all calls for fire in as direct a manner as possible.

Because the field artillery simulator will be required to actively participate in the normal maneuver battalion supporting artillery FDC loop, he must be supplied with receive-transmit equipment compatible with the VRC-47 radio set normally employed in that net. In addition, he must have the ability to command specific operators in the field through a pager activation system and communicate with them on a simulation net common frequency. An encoder device will be required to provide the discrete address capability to the various operators in the field. The field artillery simulator computer who assists the field artillery simulator must be provided with the capability to monitor these frequencies, but transmit only on the simulation net common frequency.

The 4.2-inch mortar battery simulators will be supplied with equipment capable of monitoring the normal VRC-47 communications net of the heavy mortar FDC. No ability to transmit on this frequency is required. He must have the equipment necessary to command specific operators in the field through a pager activation system and communicate with them on a simulation net common frequency.

¹ This situation is based on the assumption that field artillery (FA) batteries will not actually participate in exercises. If they do, the SNCS function is to monitor and then respond in a fashion similar to the actions of the personnel simulating the mortar batteries.

Because of the lack of adequate information, it is not possible to ascertain whether or not information to the level required to simulate 81-mm mortar fire will be available on the VRC-47 command net of the maneuver company. If SNCS must be provided this data via the PRC-77 company FDC-81 mm mortar battery net, radio relay will probably be required because of the relatively short range of the PRC-77. Whichever approach is adopted, this monitoring capability will be supplied to each 81-mm mortar simulator. No ability to transmit on this frequency is required. Each must have the equipment necessary to command specific operators in the field through a pager activation system and communicate with them on a simulation net common frequency (see Figure I-3).

It is mandatory that simulation team personnel be provided complete maneuver force communication plans via pre-exercise briefings or operation plan data.

If communications traffic is heavy on the simulation net common frequency, separate frequencies could be utilized for operators in each maneuver area. However, any SNCS position must have the ability to control any field operator to ensure maximum utilization of field personnel.

Each field operator will require a lightweight portable receiver/transmitter with preset channel selection capability in the operating range of 30 to 75.95 MHz, with sufficient range to maintain a communication link with the SNCS and the maneuver forces. In addition, each field operator will require a discrete address pager device similar to that employed in commercial telephone answering services. Neither of these items are known to be in current Army inventory.

I. TRANSPORTATION

To keep field personnel to a minimum, they must have the capability to move from position to position as tactical situations dictate. To periodically replace field personnel on site, transportation must be available to carry relief operators to the maneuver area and return the relieved personnel to the headquarters area.

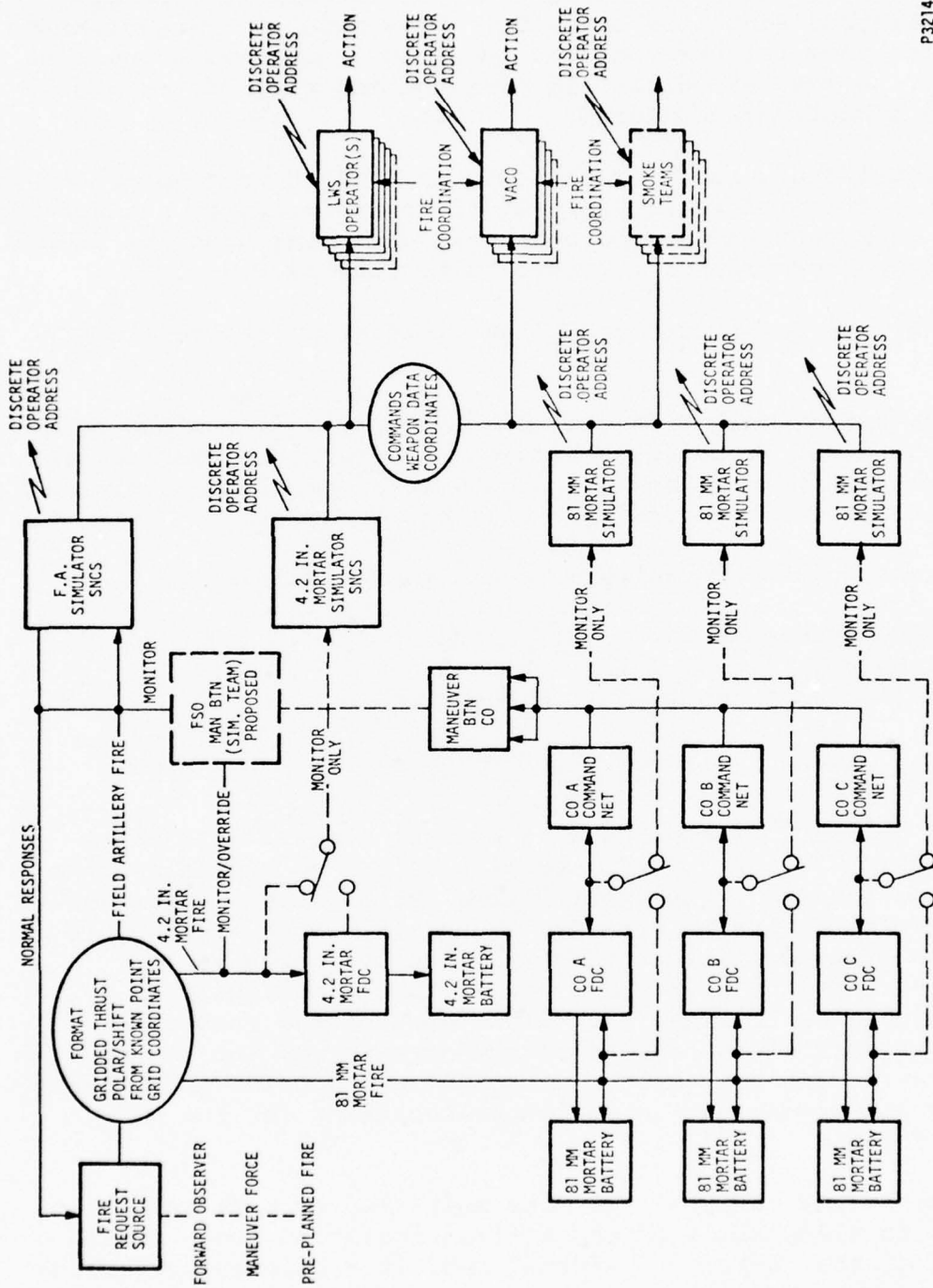

Figure I-3. Proposed Communications Net - Maneuver Force/Simulation Group

"Jeep" transportation appears satisfactory for use by the laser weapons simulator operator. This mode of transportation will provide room for carrying the required equipment, as well as the ability to move expeditiously over the majority of terrain conditions normally encountered.

Visual/Audio cue operators may be mounted in jeep or motorcycle transportation. Jeeps would be preferred to standardize unit equipment and may be necessary depending upon the number of audio/visual cue rounds required to be carried.

Vehicles should remain in the field as operators are relieved.

Truck transportation capable of carrying a minimum of 16 persons will be required to provide transportation for relief crews. Because field personnel in both areas should be relieved simultaneously, two such vehicles will be required.

Transportation requirements are summarized below:

| | |
|---------------------------|-----|
| "Jeep" vehicles | 32* |
| Trucks | 2 |

* 16 can be replaced with motorcycles

J. FACILITIES

As stated in paragraph B, a central control site designated as the SNCS is required. Because of the communication nets involved and resultant equipment/wiring installation, a permanent or semi-permanent site is strongly suggested. Such a structure would be so located within the overall maneuver area as to minimize interference with the maneuver forces and optimize communication capabilities. The floor area of the structure should be of sufficient size to permit overview of the tactical data display device by required personnel and provide sufficient work space and communication equipment locations for the performance of tasks.

The overall area of the site must also provide sufficient facilities to sleep and feed the entire simulation group during the period of the exercise. Minimal vehicle repair and refueling capabilities will be required.

SNCS personnel will require an overall awareness of the tactical situation as it develops during the exercise. Because of the fluid situation, field personnel must change positions periodically to maintain contact with maneuver forces. To provide this awareness and field personnel control, a tactical data display device is proposed.

Various alternatives are available for displaying the necessary tactical information. One approach would be to locally manufacture a horizontal display device capable of being viewed from above. The surface would be a representation of the maneuver area. Elevation contour lines, grid coordinates, prominent landmarks and planned targets would be displayed. The surface would be suitable for grease pencil annotations and symbols indicating field personnel and maneuver force locations would be moved by an operator in the SNCS through information received from field personnel.

An alternate approach would be to use a vertically mounted plexiglass board with operators writing in reverse grease pencil. Annotations would be made at the rear of the board.

Although suitable, a cathode ray tube device with alphanumeric symbology controlled by a keyboard operator, appears too costly a solution to display the required data.

K. EQUIPMENT/INSTRUMENTATION/SPARES RECOMMENDATIONS

All maneuver force personnel will require MILES instrumentation and an audio cue device to provide indirect fire simulation awareness.

| | | |
|---------------------|------------|--------------------|
| HQ and HQTRS Co. | 170 | |
| Rifle Companies (3) | 534 | |
| Combat Support Co. | 174 | |
| Tank Company | <u>112</u> | |
| | | 990 x 2 BTN = 1980 |

All vehicles in exercise will require MILES instrumentation.

| | | |
|--|------------|-------------------|
| Armored vehicles | 106 | |
| Other (trucks, trailers and the like) | 140 | |
| | <u>246</u> | 246 x 2 BTN = 492 |

| | | |
|---|---|-----|
| Each LWS operator will require an LWS device. Minimum 5 operators/BTN x 2 BTN | = | 10 |
| Each field operator will require an observer's sextant and calculator (includes smoke genera- tion teams) | = | 30 |
| Binoculars (LWS operators) | = | 10 |
| Each field operator will require individual transportation (jeep, motorcycle, Gamma-Goat)= | | 30 |
| Truck transportation to carry relief operators to field. | = | 2 |
| Portable lightweight communications set (GFE) (see paragraph F in Section IV of the final report for recommendations) | = | 30 |
| Launching device, Audio/Visual cue 8 operators x 2 BTN | = | 16 |
| Spare batteries for LWS device Worst case estimated at one replacement per device/shift (10 devices x 3 shifts x 4 days) | = | 120 |
| Discrete pager device 1 per operator in field (see paragraph F in Section IV of the panel report for recommendations) | = | 30 |
| Spares, portable lightweight Communications set (estimated) | = | 4 |
| Spares for LWS device Reliability study performed on the LWS device. Estimated spares based primarily on only mechanical damage due to mishandling 1/BTN per exercise x 2 BTN | = | 2 |

Spares for observer's sextant

Preliminary reliability study performed on the observer's sextant. Estimated spares based primarily on only mechanical damage due to mishandling.

2 BTN/per exercise x 2 BTN = 4

Communications Installation SNCS

Specific equipment not identified. Requirements exist for following frequency monitoring/transmitting capabilities.

| <u>FREQUENCY NO.</u> | <u>FUNCTION</u> |
|----------------------|---|
| 1 | RCV/XMT ARTY FDC Side A |
| 2 | RCV/XMT ARTY FDC Side B |
| 3 | RCV only, ARTY FDC Side A |
| 4 | RCV only, ARTY FDC Side B |
| 5 | RCV only, 4.2" Mortar Side A |
| 6 | RCV only, 4.2" Mortar Side B |
| 7 | RCV only, 81-mm FDC, COA Side A |
| 8 | RCV only, 81-mm FDC, COB Side A |
| 9 | RCV only, 81-mm FDC, COC Side A |
| 10 | RCV only, 81-mm FDC, COA Side B |
| 11 | RCV only, 81-mm FDC, COB Side B |
| 12 | RCV only, 81-mm FDC, COC Side B |
| 13 | Intercomm/All Stations |
| 14 | RCV/XMT All Stations-Field Oper Control Freq. |
| 15 | Pager Activation - All Stations |

NOTE: From review of available information, the above requirements could be met by use of the following normally vehicle mounted equipment in a fixed installation.

| | |
|-------------|---|
| CH 7,8,9 | (1) VRC-44 set |
| CH 10,11,12 | (1) VRC-44 set |
| CH 1,2 | (2) VRC-43 set |
| CH 5 | (1) VRC-43 set |
| CH 6 | (1) VRC-43 set |
| CH 14 | (1) VRC-43 or VRC-44 |
| | Depending upon number of field operator control frequencies employed. |
| CH 13 | Addition of audio frequency amplifier |
| CH 3,4 | Parallel CKT of CH 1,2 |
| CH 15 | Commercial Equipment, Unspecified |

SUMMATION

| | | |
|---|------|--------|
| Simulation Field Personnel | 34 | Note A |
| SNCS Personnel | 15 | Note A |
| MILES Instrumentation, Vehicles | 492 | |
| MILES, Instrumentation Personnel | 1980 | |
| Audio Cue, Miles Interface, Personnel | 1980 | |
| Laser Weapon Simulator | 10 | |
| Observer's Sextant/Calculator | 30 | |
| Binoculars | 10 | |
| Field Team Transportation Vehicle | 30 | |
| Relief Team Transportation (Truck) | 2 | |
| Portable Communications Set | 30 | |
| Launching Device, Visual/Audio Cue (M-79 Grenade Launcher) | 16 | |
| Discrete Address Pager Device | 30 | |
| Spares, Battery LWS Device | 120 | Note B |
| Spares, Portable Communications Set | 4 | Note B |
| Spares, LWS Device | 2 | Note B |
| Spares, Observer's Sextant | 4 | Note B |
| Radio Set VRC-44, Fixed Installation | 2 | (3) |
| Radio Set VRC-43, Fixed Installation | 3 | (4) |
| Audio Frequency Amplifier (Intercom) | 1 | |

Note A - Multiplied by 2 or 3 to arrive at number required to support exercise.

Note B - Estimate Only.

ANNEX 1

TO APPENDIX I

Excerpt from Tactical Operations Handbook prepared
by U.S. Army Infantry School, Fort Benning, Georgia,
July 1968.

13.17 TLP STEP 5. ISSUE ORDER. CO TF 1-66 met with his commanders and staff at the TF OP and the order was issued (OPORD 23, pg 13-40).

- a. The S2 oriented the commanders on the area of operations and the enemy situation.
- b. CO TF 1-66 then covered the friendly situation, with special attention to the 1st Bde mission; cited the mission of TF 1-66; presented the "concept of operation"; issued missions to units executing a tactical role; and covered coordinating instructions.
- c. Next the S4 covered administrative and logistical matters not SOP and insured that Co A/1-1 Armor (Tm TANKER) was familiar with the SOP of 1-66 Inf.
- d. The S3 then covered command and control items.
- e. Finally, the FSCoord and the S3 discussed the fire support plan. Forward observers had previously been provided information of planned fires by Bde and Bn, hence the unit commanders were not given a completed fire support plan at this time, or a tentative target list overlay, as may be done.
- f. The unit commanders were informed that they would receive a copy of the Fire Support Annex and a Check Point Overlay prior to the attack.
- g. CO TF 1-66 answered his subordinates' questions. He, in turn, determined if the order was understood by asking questions.
- h. Unit commanders were directed to provide the S3 with an outline of their tactical plans by 0930.

NOTE: ABOVE MANNER OF PRESENTATION DURING THE BRIEFING VARIES WITH COMMANDER.

i. After dismissing the unit commanders, the commander and staff returned to the TF CP. There, under the supervision of the XO, the planning continued. The commander and S3 departed to coordinate with the 1-74 Inf and the 1-67 Inf respectively. A LO was dispatched to 1st Bde HQ with details of the TF plan of attack. As the FSCoord completed the Fire Support Plan he coordinated it with the 1st Bde and 1-45 Arty.

13.18 TLP STEP 6. SUPERVISE. During this step CO TF 1-66 supervises the conduct of the operation as indicated below:

a. Implement Order. When the units complete preliminary preparations before departing from their assembly areas or current dispositions for the LD, CO TF 1-66 supervised, as necessary, actions to tactically dispose the force to conduct the attack.

(1) Movement and Concentration of Forces. Since TF 1-66 was in contact with the enemy, no movement of the TF to the area of operations was necessary. However, all of the attack echelon was not in contact. A check was made to see that Co C was relieving elements of Co B in zone; that the recon platoon had moved to vicinity of the right flank; and that Tm TANKER occupied an assembly area on the left flank. Tm ALFA was ready on line. Co B would remain in the left sector of the battalion, prepared to assist both Co C and Tm TANKER by fire.

(2) Final Preparation of Attack Echelon. A check was made to see that a platoon from Co C and one from Co A joined the tank company. Checks were performed to determine that resupply was accomplished and that subordinate units were preparing themselves for the attack.

(3) Development of Enemy Position. Despite the fact that last night's attack essentially developed the situation, the commander would continue to use all means available to him to learn about the enemy's strength, location, composition, and disposition before the attack began.

(4) Initiation of Preparation Fires. CO TF 1-66 insured that the preparation fires began as scheduled. The ten minute preparation beginning H-10 minutes would cover the move from current dispositions past the LD.

NOTE: The actions taken above by the commander reflect some of the more essential ones that may be made during the preparatory phase. There are, of course, many last minute details to be supervised. The extent to which the commander exercises direct supervision will depend, among other things, on the time available and the skill of his staff.

b. Influence Conduct of Operation. As the units began to move toward the LD, CO TF 1-66, assisted by his staff, continued to supervise. Initially, he positioned himself at the battalion OP until the units crossed the LD and were moving to their assault positions. Then, with his command group, he assumed a position behind Tm ALFA. The commander foresaw no difficulty to place more fire on this enemy unit if necessary. By being close to Tm ALFA, the commander was in the best position to receive personal information of this initial engagement with the enemy.

Conduct of the Attack. Throughout the conduct of the attack, CO TF 1-66 will continually revise his estimate of the situation and plan of attack as developments occur.

(1) Situation. (The situation is as shown on Sketch Map G, pg 13-37). The attack commenced as planned. The enemy force in the zone of Tm ALFA opened fire on them and was immediately taken under fire by Tm ALFA. In the meantime, Co C advanced in zone and outflanked them. When the enemy force realized their precarious position, they attempted to withdraw, but were caught between the cross fire of Tm ALFA and Co C. Many casualties were inflicted on the enemy.

(a) The attack progressed; CO Co C reported that as his unit neared the ridge south of HILL 450.2, it was taken under fire by enemy at that position. His attack had been slowed and they received some casualties. Tm ALFA's attack had been slowed down.

(b) Subsequently, CO Co C reported that he obtained a hold on the ridge and continued to receive heavy fire from ARGO. His progress was slow and there was still some enemy on the position. He requested additional fires and some smoke be placed on ARGO and an air strike on the enemy armor located north of there. CO Tm ALFA reported that he committed his reserve and should be able to reduce the enemy defenses on HILL 415.1 within approximately an hour. He requested an additional platoon so that he could continue the attack to seize Obj 20.

(c) CO TF 1-66 told his FSCOORD to give Co C more fires and smoke, and he also told his FAC to request an air strike on the enemy north of ARGO. According to plan, he ordered Tm TANKER to begin their movement to seize Obj 30. He alerted Co B to be prepared to move behind Tm TANKER. The enemy recon platoon withdrew into the town of DALE when Tm TANKER approached.

(d) As Tm TANKER neared ARGO, they received heavy fire from the enemy in that vicinity. The additional artillery fire placed on ARGO did not reduce this enemy fire. The advance slowed down and CO Tm TANKER reported that his unit could not bypass the area without receiving heavy casualties. Fire was also being received from DALE. His zone of action was effectively covered by the enemy located in vicinity of ARGO and DALE.

(e) Reports of CO TF 1-66 indicated that the enemy had not moved any of his units, and therefore, he still assumed that HILL 475 was unoccupied.

His original plan was to fix the enemy in place on HILL 415.1 and RIDGE 450.1 450.2. He hoped to achieve surprise and occupy HILL 475 before the enemy could deduce his intent and react to occupy the objective of his main attack. There were no indications that the enemy was occupying HILL 475. The intent of CO TF 1-66 was for Tm TANKER to take advantage of their speed and maneuver capability and occupy HILL 475; however, enemy fire from ARGO must be reduced before the attack could continue. Additional fires on ARGO did not accomplish this; therefore, it became necessary for the commander to modify his plans.

(1) The request of Tm ALFA for an additional platoon was not approved. CO TF 1-66 felt that the purpose of Tm ALFA was being accomplished by their fixing the enemy in their zone. The key to the battalion's attack, and to brigade operation, was HILL 475 and the commander did not desire to detract from this objective.

(2) CO TF 1-66 considered ordering Tm TANKER to attack and reduce ARGO. His plan was for an envelopment of the enemy's position, and to attack ARGO with Tm TANKER would mean a frontal attack. This action would force the enemy to withdraw toward and possibly occupy HILL 475. His mission would not be facilitated by such action. CO TF 1-66 ordered Tm TANKER not to attack ARGO.

(3) CO TF 1-66 considered using Co B, the battalion reserve, to attack ARGO. He recalled also that the battalion's left flank was the most vulnerable and this was one of the reasons for placing Co B on the left. In addition, he did not desire to commit his reserve against an objective he did not consider decisive.

(4) CO TF 1-66 decided that Co C was in the best position to reduce ARGO without altering drastically his original plan of attack. This would mean an attack on ARGO at this time was necessary since other action taken had not succeeded. In order for Co C to attack ARGO and force the enemy to shift this emphasis away from Tm TANKER, additional support must be given to Co C.

(5) See Sketch Map H, Plan of Action (pg 13-38).

e. Accomplish Mission. The seizure of Objective 30 would not indicate that the mission had been completely accomplished. TF 1-66 must consolidate and reorganize as soon as practicable. It must be prepared for a possible enemy counterattack. Based on orders received from brigade, TF 1-66 prepares to continue the attack, revert to reserve, assist the passage of another unit, or to defend on the position.

(1) When the attack on ARGO began, enemy fire against Tm TANKER was reduced substantially. Tm TANKER continued its attack and seized Obj 30 against token enemy resistance.

(2) Co C gained a foothold in ARGO and was in the process of mopping up the remnants of the enemy still in the town.

(3) Tm ALFA continued its attack to seize Obj 20.

(4) Co B moved to a blocking position west of ARGO and was prepared to join Tm TANKER on Obj 30 or to assist in seizure of Obj 10.

(5) Tm ALFA, assisted by Tm TANKER's fire, was able to seize Obj 20. Some of the enemy from Obj 20 withdrew along HWY 2 to the northeast. Enemy forces on Obj 10 were successfully enveloped.

(6) Tm TANKER, after it secured Obj 30, attacked to destroy the enemy forces on Obj 10.

(7) CO TF 1-66 reported to brigade headquarters that Obj Y had been seized and that TF 1-66 was still cleaning up the remnants of the enemy force left in the area. TF 1-66 was not prepared at this time to continue the attack, but was prepared to assist the passage of 1-68 Inf.

(8) CO TF 1-66 then supervised the consolidation of the reorganization on the objective. At the same time, together with his staff, he began consideration of the sequence of actions to accomplish Phase II, either as brigade reserve or to continue the attack. Once the objective had been secured, TF 1-66 would occupy defensive positions and await orders.

SKETCH MAP H - PLAN OF ACTION

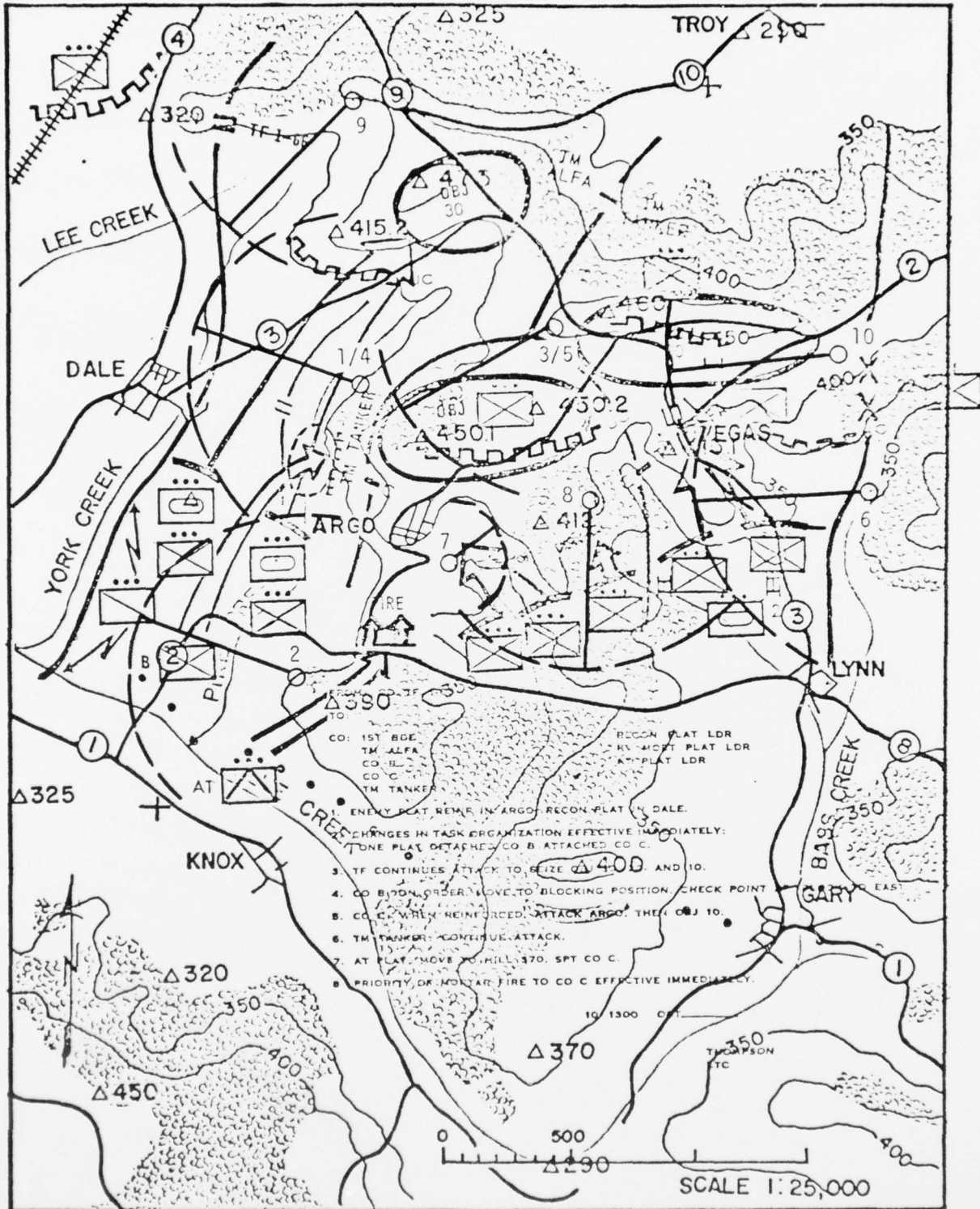

1. LWS OPERATORS PLACED AS SHOWN AT START OF ENGAGEMENT
2. 750 METER NORMAL RADIUS ILLUSTRATED

P3242

APPENDIX J

LOW COST INDIRECT-FIRE SIMULATION LOCATION SUBSYSTEM

TABLE OF CONTENTS

| <u>Section</u> | <u>Title</u> | <u>Page</u> |
|----------------|---|-------------|
| A | DISCUSSION | J-3 |
| | 1. General. | J-3 |
| | 2. Applications to Real Artillery Problems. | J-3 |
| B | IMPLEMENTATION | J-4 |
| | 1. Calculators. | J-4 |
| | a. SR-52 Program for Position Finding | J-4 |
| | b. Example of Position-Finding and Target Point Location | J-6 |
| | c. Auxiliary Calculator Program for Target Point Location | J-12 |
| | d. Second Supplementary Calculator Program for Future Vantage Location. | J-12 |
| | 2. Procedure for Self-Location Using Calculator and Observer's Sextant | J-15 |
| | 3. Range Preparation. | J-20 |
| | a. Practical Aspects. | J-20 |
| | b. Rotating Beacons/Power Requirement for Night Position Finding | J-23 |
| | 4. Design Scheme for Observer's Sextant | J-25 |
| | a. Discussion | J-25 |
| | b. Measurement of Relative Bearings in a Horizontal Plane | J-27 |
| | c. Concept for Improved Observer's Sextant. | J-31 |
| | 5. Field Records and Forms. | J-37 |
| | 6. Conclusion | J-41 |

LIST OF ILLUSTRATIONS

| <u>Figure</u> | <u>Title</u> | <u>Page</u> |
|---------------|---|-------------|
| J-1 | Example of Position Finding and Target Point Location | J-10 |
| J-2 | Proof Problem for Position Location Program and Target Range and Bearing Supplement. | J-11 |
| J-3 | Monument Configurations (typical). | J-21 |
| J-4 | Example of Range Monument Distribution | J-22 |
| J-5 | Rotating Beacon's Optics | J-24 |
| J-6 | Range Rotating Beacon. | J-26 |
| J-7 | Plan of Optics and Nature of View Through Slit . | J-28 |
| J-8 | Improved Sextant Optics. | J-32 |
| J-9 | Improved Observer's Sextant Concept. | J-33 |
| J-10 | Observer's Sextant | J-35 |
| J-11 | Self Location: Card #1 E-Enable | J-38 |
| J-12 | Target Location: Card #2. | J-39 |
| J-13 | Object Location: Card #2 E-Enable | J-40 |

LOW COST INDIRECT-FIRE SIMULATION LOCATION SUBSYSTEM

A. DISCUSSION

1. General

The use of radio frequency position location schemes (such as RMS/SCORE) will be very expensive. The cited system can, with add-ons, do the paging function and data transmission function, but the major cost of the system is the position-finding capability. Quite conventional radio means of low cost are available for the other functions.

Ordinarily, the thought of position-finding (self-fix) by observation of angles to known objects with known map coordinates, engenders visions of use of transits or aiming circles on tripods and laborious graphical map resection. Until quite recently this would have been the case, except that the use of a "surveyor's sextant" - a hand-held device - could be used for the angle measurement.

The new technique available is the result of the advent of hand-held programmable calculators of truly enormous capability for their small size and cost.

With such a device available to fielded personnel together with a catalog of fixed objects and their grid coordinates, it is only necessary to enter the six numbers representing the "Easting" and "Northing" of three such objects visible from a point, then measure the two angles observable between the three objects, enter them, press a button, and after about 10 seconds the program is complete. The observer's grid coordinates are read from the calculator as well as the bearing from grid north of the central object. The whole function requires well less than two minutes with a dedicated calculator, and a trained observer. This is a quite acceptable period of time. Accuracy is far better than map resection can yield - it is limited only by the accuracy of the coordinate data (which can be very good) and by the accuracy of angle measurement.

2. Applications to Real Artillery Problems

With a calculator with several "canned" programs available by switch selection, an exceedingly versatile system of calculator and sextant is available which should speed the efforts of forward observers and make feasible, using relative bearings of targets

from two or more observers at known locations, the use of FIRST-FIRE-FOR-EFFECT. The location of batteries or individual cannons or mortars can be found easily (together with accurate azimuth data) to implement HASTY-FIRST-FIRE-FOR-EFFECT - an exceedingly valuable capability in mobile, fluid battlefield situations. It is inconceivable that this capability will long be ignored.

B. IMPLEMENTATION

1. Calculators

Ultimately, specialized calculators with "canned" programs are essential. These should cost little more than the exceedingly versatile "programmable" hand-held calculators such as the Texas Instruments SR-52 which currently retails at slightly over \$250.00. The latter has a disadvantage in that the programs are "volatile" - they disappear from "program memory" when the device is turned "off".

The programs, once keyed into program memory (up to 224 program key-strokes) can be recorded on small magnetic cards, and thereafter re-read into the calculator at any later time for use. This takes only a few seconds, but card-storage and reading is a nuisance and cards can be damaged by mishandling. Further, such very versatile calculators incorporate many functions which are totally unnecessary for the field uses envisioned as well as a number of automatic internal programs which are unnecessary. A "dedicated" calculator with "canned" program memory is ultimately to be preferred. This is well within the capability of the producers of such devices.

Another factor which is not adapted to field use is the limited battery capacity of these devices. For field use, the usual battery pack (snapped into the back of the SR-52) should be replaced by an alkaline battery pack of at least 5 times the capacity of the present very small Ni-Cad cells. Storage cells of any type, even though routinely recharged always leave some uncertainty of available "on" time. Where great reliability for a definite period is needed, fresh alkaline cells available as "spares" are to be preferred.

a. SR-52 Program for Position Finding

We have worked out a key-stroke program for the SR-52 to perform the functions as noted above. It is included herewith. Calculation involving eight numbers and solution of the dual-oblique trigonometric problem required, is a "long" process and

without "sneaky tricks", could not have been keyed into SR-52, 224-stroke program memory. Indeed, the program requires all but one of them.

A critical feature is that the program must work from any viewing aspect of the observed objects (that is -- looking basically south, north, east or west; indeed in any direction). This is what causes some of the "sneakiness" and obscurity of the program. It works quite well, however, provided the routine is followed properly.

In order to even come close to fitting the program into 224 key strokes, it is necessary to use a "decrement and skip on zero" subroutine, together with indirect memory addressing, to enter the six object grid coordinate data, and as a result they must be entered in a fixed order as follows:

- (1) First press "E" to enter a count of 6 coordinates in register 00. Starting with the most counterclockwise object in view, looking generally toward the central one, enter first the EASTING of the most counterclockwise object, press A, then its NORTHING, again press A. This enters these data into memory registers 06 and 05.
- (2) Continue with the coordinates of the central object, first EASTING, next NORTHING, pressing A after each entry. These numbers are thus entered in registers 04 and 03.
- (3) Repeat the procedure for the most clockwise or right-hand object, first EASTING, A, then NORTHING, A. These are entered in registers 02 and 01.
- (4) Enter the angle between the most counterclockwise object and the central one in degrees and hundredths. Press B.
- (5) Enter the angle between the central and most clockwise (right hand) objects in degrees and hundredths. Press C.
- (6) Run the program by pressing RUN. The grid-north reference bearing of the central object appears displayed in MILS. It is also stored in register 12 and can be recalled by pressing RCL, 1, 2. If the displayed bearing exceeds 6400, subtract 6400 for the correct value.

(7) The observer's EASTING is stored in register 00 and can be recalled by pressing RCL, 0, 0.

(8) The observer's NORTHING is stored in register 11 and can be recalled by pressing RCL, 1, 1. The recall function can be used repeatedly. See Table J-1 for SR-52 user instructions and coding.

A feature of the program is that it returns to the point of entry of the angle data so that, as an observer moves about, he need not re-enter the object coordinate data, but merely re-enter new relative angle data as measured by the sextant, always starting with the least clockwise (left-hand) angle. Pressing RUN then yields his new bearing and location data.

Of course, if one object is no longer visible, new coordinate data must be keyed in using the proper order as noted or if the left-to-right order of the observed objects changes as a result of observer movement, the changed order of coordinates must be rekeyed after first pressing 2ND CMS to clear memories.

b. Example of Position-Finding and Target Point Location
(Figure J-1)

Example: The map used is "POR #1 of C-69" showing a region of West Germany north of the Mosel River. The accuracy of the locations is purely fictitious as there is no way of getting such accuracy from the map. The angles were measured with a protractor from arbitrary points.

Objects A: Church Spire in Sehlem, E=44775, N=30470
B: Standpipe north of Salmrohr, E=45700, N=33110
C: Stack in Pohlbach, E=47420, N=31440
 $\beta_1 = 66.67^\circ$
 $\beta_2 = 51.92^\circ$ (objects in above order)

Result: Bearing Standpipe at Salmrohr = 6291 μ
 $E_0 = 46025$
 $N_0 = 30083$ on the slope east of the stream
Same objects in order Salmrohr, Pohlbach, Sehlem as seen from west,
 $\beta_1 = 42.7^\circ$
 $\beta_2 = 55.5^\circ$

Result: Bearing of Stack in Pohlbach = 1810 μ
 $E_0 = 44077$
 $N_0 = 32140$ on the slope east of the NE/SW road.
The agreement is excellent (see Figure J-2 for proof problem).

Table J-1. Observer Location by Relative Bearings

| ←A← | | ←B← | | |
|--------------|---|-------------|-----------|--|
| STORE COORDS | STORE LEFT | STORE RIGHT | ENABLE | |
| STEP | PROCEDURE | ENTER | PRESS | DISPLAY |
| 1 | READ BOTH SIDES OF CARD | SIDE A | 2ND READ | 0 |
| | | SIDE B | 2ND 12BRD | 0 |
| 2 | ENABLE | | E | 6 |
| 3 | ENTER E COORD. OF LEFT-MOST OBJECT E_L | | A | E_L |
| | ENTER N " " " " " N_L | | A | N_L |
| | ENTER E COORD. OF CENTRAL OBJECT E_C | | A | E_C |
| | ENTER N " " " " " N_C | | A | N_C |
| | ENTER E COORD. OF RIGHT-MOST OBJECT E_R | | A | E_R |
| | ENTER N " " " " " N_R | | A | N_R |
| → 4 | ENTER LEFT-MOST ANGLE, DEG. β_L | | B | β_L |
| | " RIGHT-MOST " " β_R | | C | β_R |
| 5 | RUN PROGRAM | | RUN | BEARING OF CENTRAL OBJECT |
| 5-A | IF DISPLAY EXCEEDS 6400, HBY AS FOLLOWS: -, 6, 4, 0, C, =, STO, 1, 2. | | | MILS REF GRID NORTH. ALSO IN REG 12 |
| 6 | READ OBSERVER E COORDINATE | | RCL 0 0 | E_0 , METERS |
| 7 | " " N COORDINATE | | RCL 1 1 | N_0 , METERS |
| 8 | " BEARING OF CENTRAL OBJECT, MILS REF. GRID NORTH | | RCL 1 2 | B_{0C} , MILS |
| | NOTE: PROGRAM RETURNS TO STEP 4 SO THAT OBJECT COORD'S NEED NOT BE REENTERED UNLESS CALCULATOR IS TURNED "OFF", OR ORDER OF OBJECTS CHANGES DUE TO OBS-MOVEMENT | | | |
| 9 | TO USE NEW OBJECT-COORDINATES | | 2ND CMS | |
| | AND START AT STEP 2, | | E | |
| | | | ↓ etc. | |

Table J-1. Observer Location by Relative Bearings (cont'd)

| LOC | CODE | KEY | COMMENTS | LOC | CODE | KEY | COMMENTS | LOC | CODE | KEY | COMMENTS | LABELS | |
|------------|------|------|---|----------------|------------|-----|----------|----------------|------------|------------|----------------|-------------------|--|
| 000 112 | 46 | *LBL | ↑ ENABLE COORD LOAD MODULE | | 42 | STO | | | 00 | 0 | Y _A | A | |
| | 15 | E | | | | 00 | 0 | | | 03 | 3 | Y _A | B |
| | 06 | G | | | 040 152 | 00 | 0 | | | | 95 | = | C |
| | 42 | STO | | | | 43 | RCL | | | | 22 | INV | D |
| | 00 | 0 | | | | 00 | 0 | Y _C | 080 192 | 39 | *P/R | | E |
| 005 117 | 00 | 0 | ↑ LOAD G COORD'S USING A IN PROPER SEQ | | 05 | 5 | | | | 42 | STO | A | |
| | 46 | *LBL | | | | 75 | - | | | | 01 | 1 | B |
| | 87 | *1 | | | 045 157 | 43 | RCL | | | | 07 | 7 | C |
| | 81 | HLT | | | | 00 | 0 | Y _A | | | 43 | RCL | D |
| | 46 | *LBL | | | | 03 | 3 | | 085 197 | 00 | 0 | | E |
| 010 122 | 11 | A | ↑ LOAD G COORD'S USING A IN PROPER SEQ | | 95 | = | | | | 00 | 0 | REGISTERS | |
| | 36 | *IND | | | | 22 | INV | | | | 55 | ÷ | 00 MANT X ₀ |
| | 42 | STO | | | 050 162 | 39 | *P/R | | | | 43 | RCL | 01 Y _B |
| | 00 | 0 | | | | 42 | STO | | | | 01 | 1 | 02 X _B |
| | 00 | 0 | | | | 01 | 1 | φ | 090 202 | 08 | 8 | φ | 03 Y _A |
| 015 127 | 58 | *DSZ | ↑ LOAD G COORD'S USING A IN PROPER SEQ | | 09 | 9 | | | | 55 | ÷ | 04 X _A | |
| | 87 | *1 | | | | 43 | RCL | | | | 43 | RCL | 05 Y _C |
| 017 | 81 | HLT | | | 055 167 | 00 | 0 | | | | 00 | 0 | 06 X _C |
| | 46 | *LBL | | | | 00 | 0 | | | | 08 | 8 | 07 0 _C , DEC |
| | 12 | B | | | | 42 | STO | | | 095 207 | 32 | SIN | 08 0 _B , DEC |
| 020 132 | 42 | STO | ↑ ENTER 2 BEARINGS (RELATIVE) | | 01 | 1 | φ | | | 65 | X | 09 | |
| | 00 | 0 | | | | 08 | 8 | | | | 43 | RCL | 10 |
| | 07 | 7 | | | 060 172 | 43 | RCL | | | | 00 | 0 | 11 Y ₀ |
| | 81 | HLT | | | | 00 | 0 | X _D | | | 07 | 7 | 12 B _{RC} , M _{AS} , M _{KS} |
| | 46 | *LBL | | | | 02 | 2 | | 100 212 | 32 | SIN | | 13 |
| 025 137 | 13 | 0 | ↑ ENTER 2 BEARINGS (RELATIVE) | | 75 | - | | | | 95 | = | K | 14 α |
| | 42 | STO | | | | 43 | RCL | | | | 20 | *1/A | 15 Δ |
| | 00 | 0 | | | 065 177 | 00 | 0 | X _A | | | 42 | STO | 16 1/A |
| | 08 | 8 | | | | 04 | 4 | | | | 01 | 1 | 17 φ |
| | 81 | HLT | | | | 95 | = | | 105 217 | 06 | 6 | 1/A | 18 φ |
| 030 142 | 43 | RCL | ↑ ENTER 2 BEARINGS (RELATIVE) | | 42 | STO | | | | 43 | RCL | 19 φ | |
| | 00 | 0 | | X _C | | 00 | 0 | | | | 01 | 1 | FLAGS |
| | 06 | G | | | 070 182 | 00 | 0 | | | | 09 | 9 | φ |
| | 75 | - | | | | 43 | RCL | | | | 75 | - | 1 |
| | 43 | RCL | | | | 00 | 0 | Y _B | 110 222 | 43 | RCL | | 2 |
| 035 147 | 00 | 0 | ↑ ENTER 2 BEARINGS (RELATIVE) | | 01 | 1 | | | | 01 | 1 | φ | 3 |
| | 04 | 4 | | X _A | | 75 | - | | | | | | 4 |
| | 95 | = | | | 075 187 | 43 | RCL | | | | | | |

Table J-1. Observer Location by Relative Bearings (cont'd)

| LOC | CODE | KEY | COMMENTS | LOC | CODE | KEY | COMMENTS | LOC | CODE | KEY | COMMENTS | LABELS |
|-------------------------------|------|--------|-------------------------|-------------------------------|------|--------|----------------|-------------------------------|------|--------|----------------------|-----------|
| ⁰⁰⁰ ₁₁₂ | 07 | 7 | $\phi - \theta$ | | 01 | 1 | α | | 01 | 1 | | A |
| | 75 | - | | | 04 | 4 | | | 43 | RCL | | B |
| | 43 | RCL | | ⁰⁴⁰ ₁₅₂ | 32 | SIN | SIN α | | 00 | 0 | | C |
| | 00 | 0 | β_c | | 65 | X | | | 03 | 3 | | D |
| | 07 | 7 | | | 43 | RCL | | ⁰⁸⁰ ₁₉₂ | 44 | SUM | | E |
| ⁰⁰⁵ ₁₁₇ | 75 | - | | | 01 | 1 | γ | | 01 | 1 | $Y_0 (N_0)$ | A' |
| | 43 | RCL | | | 08 | 8 | | | 01 | 1 | | B |
| | 00 | 0 | β_B | ⁰⁴⁵ ₁₅₇ | 55 | \div | | | 43 | RCL | | C' |
| | 08 | 8 | | | 43 | RCL | | | 00 | 0 | | D' |
| | 95 | = | $\phi - \alpha - \beta$ | | 00 | 0 | | ⁰⁸⁵ ₁₉₇ | 04 | 4 | | E' |
| ⁰¹⁰ ₁₂₂ | 42 | STO | | | 07 | 7 | | | 44 | SUM | | REGISTERS |
| | 01 | 1 | A | | 32 | SIN | SIN β_c | | 00 | 0 | $X_0 (E_0)$ | 00 |
| | 05 | 5 | | ⁰⁵⁰ ₁₆₂ | 95 | = | R _A | | 00 | 0 | | 01 |
| | 33 | COS | | | 42 | STO | | | 02 | 2 | | 02 |
| | 85 | + | | | 00 | 0 | FOR P/R | ⁰⁹⁰ ₂₀₂ | 07 | 7 | | 03 |
| ⁰¹⁵ ₁₂₇ | 43 | RCL | | | 00 | 0 | | | 00 | 0 | | 04 |
| | 01 | 1 | $1/X$ | | 43 | RCL | | | 75 | - | | 05 |
| | 06 | 6 | | ⁰⁵⁵ ₁₆₇ | 01 | 1 | ϕ | | 43 | RCL | | 06 |
| | 95 | = | | | 09 | 9 | | | 01 | 1 | | 07 |
| | 55 | \div | | | 75 | - | | ⁰⁹⁵ ₂₀₇ | 02 | 2 | | 08 |
| ⁰²⁰ ₁₃₂ | 43 | RCL | | | 43 | RCL | | | 95 | = | | 09 |
| | 01 | 1 | | | 00 | 0 | β_c | | 65 | X | | 10 |
| | 05 | 5 | | ⁰⁶⁰ ₁₇₂ | 07 | 7 | | | 01 | 1 | | 11 |
| | 32 | SIN | COT α' | | 75 | - | | | 06 | 6 | | 12 |
| | 95 | = | | | 43 | RCL | | ¹⁰⁰ ₂₁₂ | 00 | 0 | | 13 |
| ⁰²⁵ ₁₃₇ | 20 | *1/X | | | 01 | 1 | α | | 55 | \div | | 14 |
| | 22 | INV | | | 04 | f | | | 09 | 9 | | 15 |
| | 34 | TAN | α' | ⁰⁶⁵ ₁₇₇ | 85 | + | | | 95 | = | | 16 |
| | 80 | *IFPS | | | 01 | 1 | | | 42 | STO | | 17 |
| | 01 | 1 | | | 08 | 8 | | ¹⁰⁵ ₂₁₇ | 01 | 1 | CENTRAL BRG. (MILES) | 18 |
| ⁰³⁰ ₁₄₂ | 04 | 4 | | | 00 | 0 | | | 02 | 2 | | 19 |
| | 09 | 9 | | | 95 | = | | | 41 | GTO | RETURN TO POINT | 0 |
| | 85 | + | | ⁰⁷⁰ ₁₈₂ | 42 | STO | | | 00 | 0 | OF ANGLE | 1 |
| | 01 | 1 | | | 01 | 1 | ϵ | ¹¹⁰ ₂₂₂ | 01 | 1 | ENTRY. | 2 |
| | 08 | 8 | | | 02 | 2 | | | 07 | 7 | | 3 |
| ⁰³⁵ ₁₄₇ | 00 | 0 | | | 39 | *P/R | | | | | | 4 |
| | 95 | = | | | 42 | STO | | | | | | |
| | 42 | STO | | ⁰⁷⁵ ₁₈₇ | 01 | 1 | | | | | | |

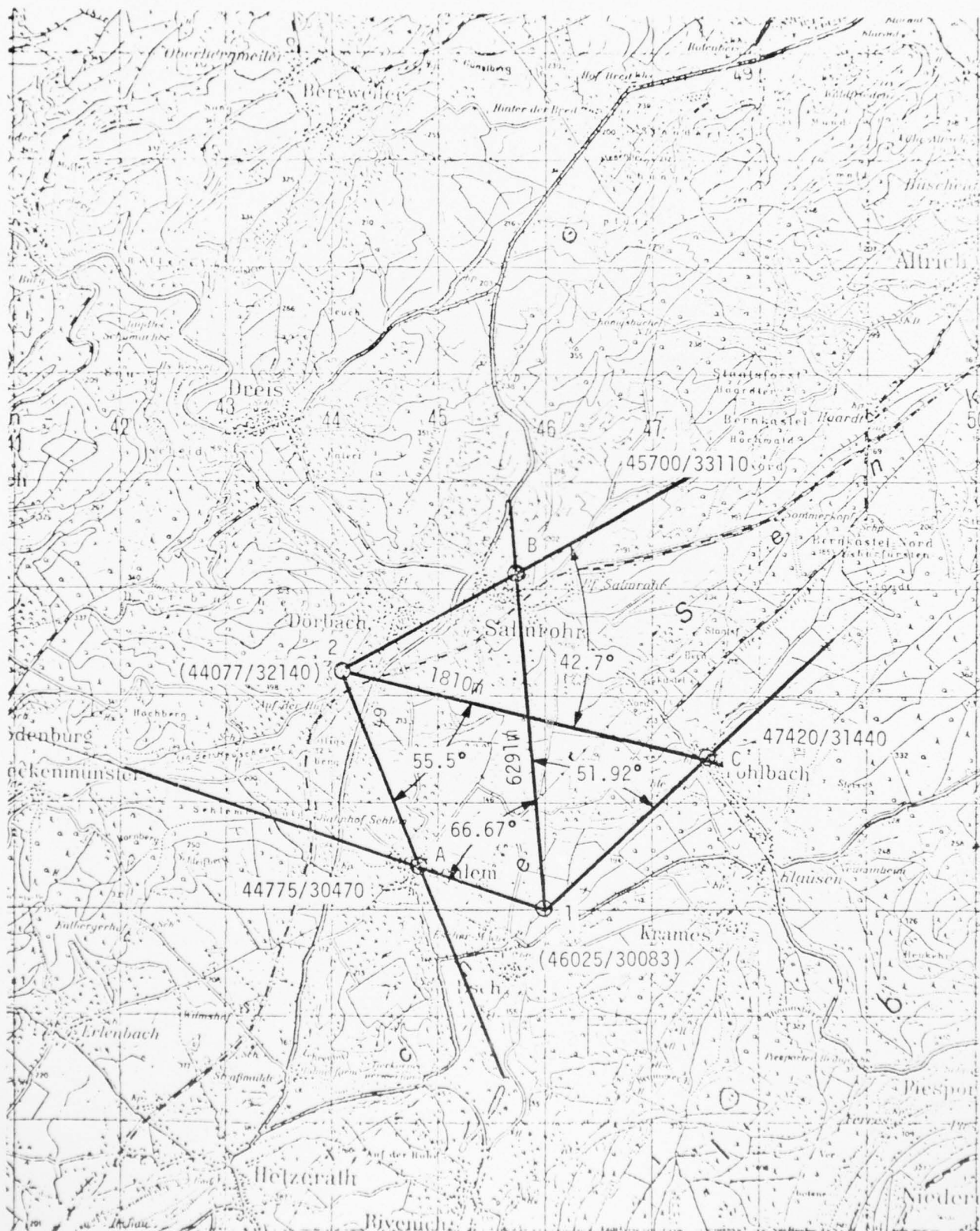
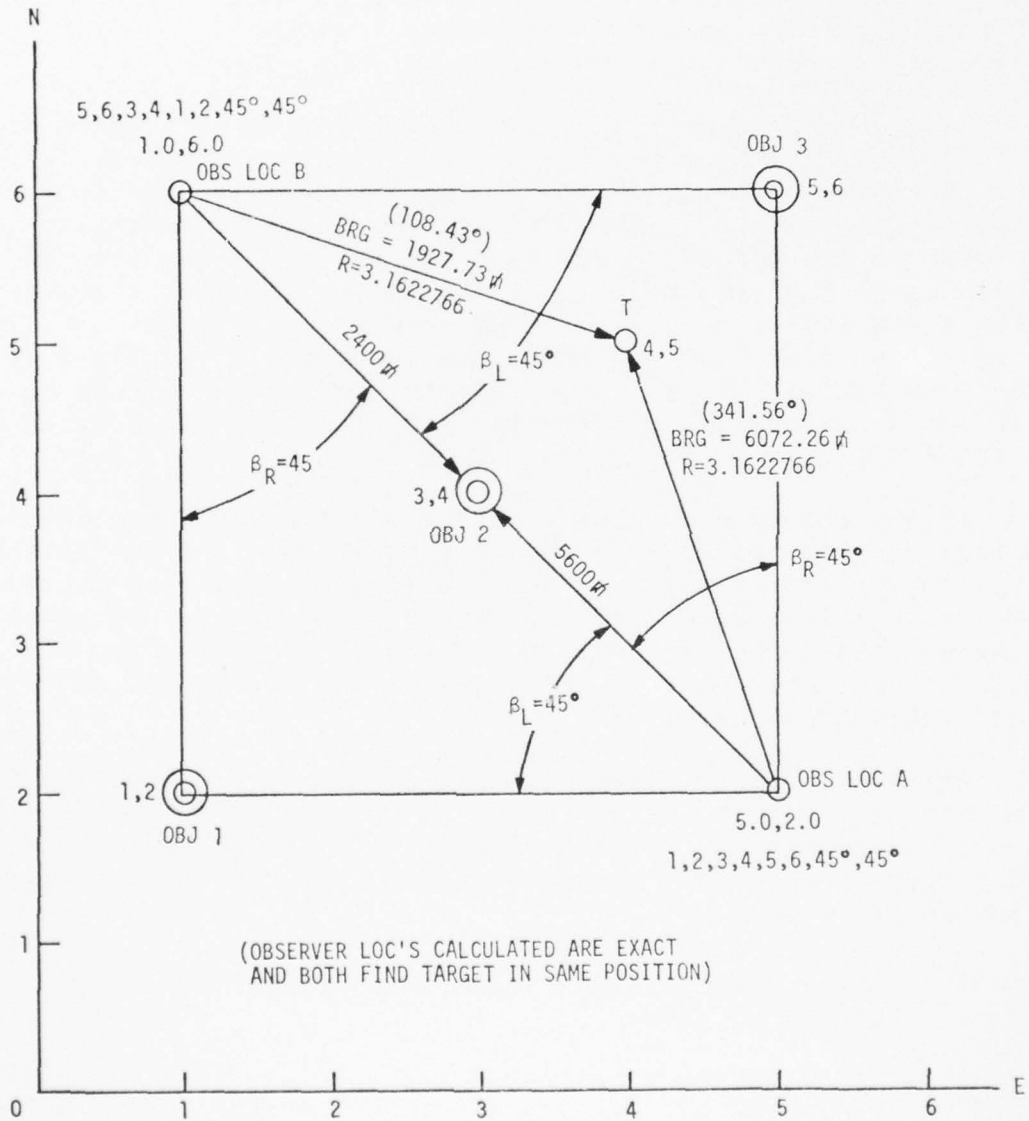

Figure J-1. Example of Position Finding and Target Point Location p3239

PROOF PROBLEM FOR POSITION LOCATION PROGRAM
AND TARGET RANGE AND BEARING SUPPLEMENT



P3215

Figure J-2. Proof Problem for Position Location Program and Target Range and Bearing Supplement

AD-A034 453

INTERNATIONAL LASER SYSTEMS INC ORLANDO FLA
INDIRECT/AREA FIRE WEAPONS EFFECT SIMULATOR STUDY. VOLUME II. P--ETC(U)
JAN 77 R E ODOM

F/G 19/5

N61339-76-C-0070

UNCLASSIFIED

TND-TR-76-0002-VOL-2

NL

4 of 4
ADA034453

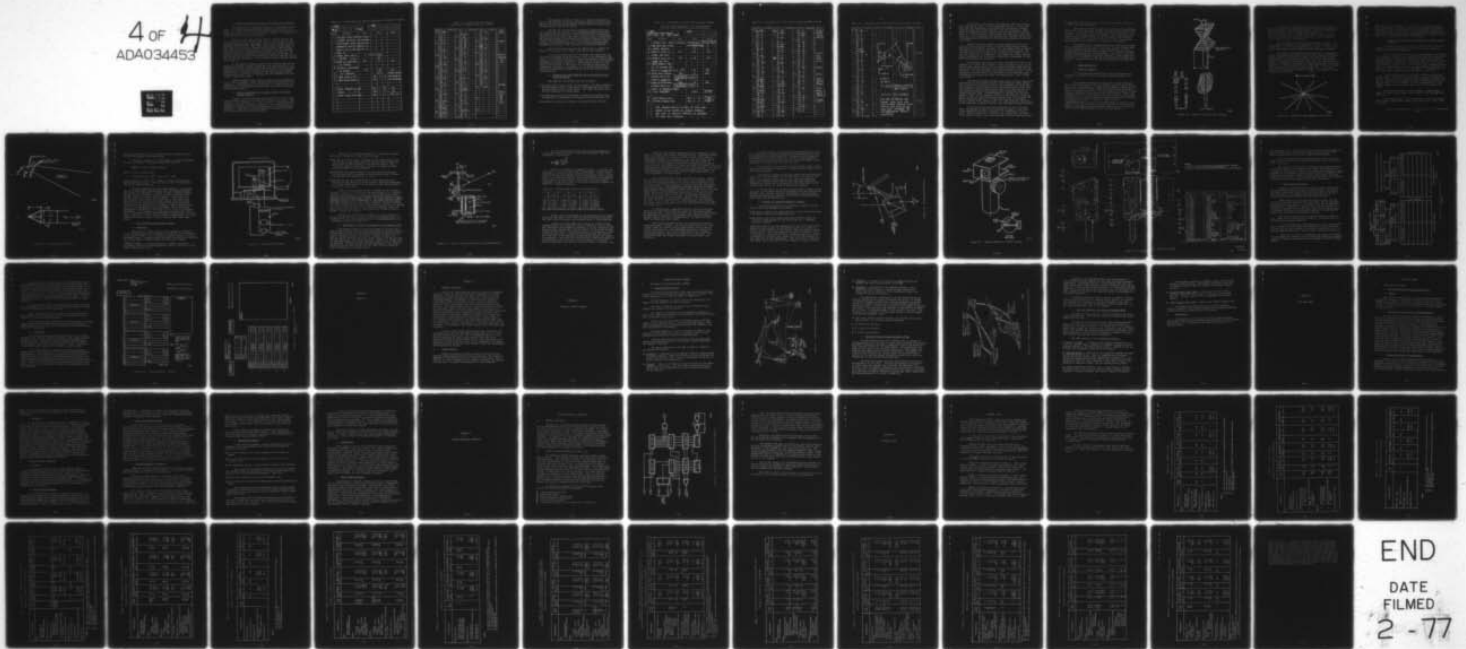

END
DATE
FILMED
2 - 77

c. Auxiliary Calculator Program for Target P

The second useful calculator program is a supplementary program. It yields the range (meters) and bearing (mils north) of a target point from an observer's present position (either the laser or visual cue operator's location). See the manual for SR-52 user instructions and coding.

Having run the self-location program, without the calculator, side A of the second card is run through the reader by pressing "CLR, 2ND, READ". The program is run as before by pressing E. Then enter the E_T and N_T coordinates (in that order) of the target, pressing A after each. The program will then leave the grid bearing of the target from the observer's position (in MILS) in the display and stored in register 16. The range to target from observer in meters is stored in register 15 and the observer's E and N UTM coordinates have been stored in registers 18 and 19 respectively, with the central-object coordinate in register 17.

If the observer changes position after having run the supplementary program, he must re-read the first card and re-enter the observed object and coordinates and bearings from his new position because the critical memories have been re-used for new data. Register 00 is a "special" register in the SR-52 having special capabilities in the "Polar to Rectangular" and "Decrease to Zero" subroutines used.

Observers should carry "spare" cards to avoid the possibility one is lost or damaged. Cards can be reproduced by the field masters in a few moments with no difficulty. An observer should repeatedly key in new target coordinates and read range from any one position.

d. Second Supplementary Calculator Program for Vantage Location

There is a second supplementary program to the self-location program which can be used after running the first program is very valuable, for it will allow the field personnel to locate a number of objects in their near vicinity in advance for quick displacement to accurate positions. (They must, of course maintain a description of the points with coordinates recorded.)

Table J-2. Target Range and Bearing
Supplement to Observer Location (cont'd)

| LOC | CODE | KEY | COMMENTS | LOC | CODE | KEY | COMMENTS | LOC | CODE | KEY | COMMENTS | LABELS |
|------------|---------------|------|----------|------------|------|---------|----------|------------|----------------|------|----------|-------------------|
| 000 112 | 46 | *LBC | | | 00 | 0 | | | 43 | RCL | | A ENTER ET, NT |
| | 15 | E | | | 58 | *d32 | | | 01 | 1 | | B |
| | 03 | 3 | | 040 152 | 87 | *1 | | | 00 | 0 | | C |
| | 06 | 6 | | | 81 | HLT | | | 44 | SUM | | D |
| | 00 | 0 | | | 43 | RCL | | 080 192 | 01 | 1 | | E ENABLE |
| 005 117 | 42 | STO | | | 01 | φ | | | 02 | 2 | | A' |
| | 01 | 1 | | | 08 | 8 | | | 053 | (| | B' |
| | 00 | 0 | | 045 157 | 94 | +/- | | | 43 | RCL | | C' |
| | 43 | RCL | | | 85 | + | | | 01 | 1 | | D' |
| | 00 | 0 | | | 43 | RCL | | 085 197 | 02 | 2 | | E' |
| 010 122 | 00 | 0 | | | 00 | 0 | | | 65 | X | | REGISTERS |
| | 42 | STO | | | 02 | 2 | | | 01 | 1 | | 00 T&T RANGE |
| | 01 | 1 | | 050 162 | 95 | = | | | 06 | 6 | | 01 NT |
| | 08 | 9 | | | 42 | STO | | | 00 | 0 | | 02 ET |
| | 42 | RCL | | | 00 | 0 | | 090 202 | 55 | ÷ | | 03 |
| 015 127 | 01 | 1 | | | 00 | 0 | | | 09 | 9 | | 04 |
| | 01 | 1 | | | 43 | RCL | | | 54 |) | | 05 |
| | 42 | STO | | 055 167 | 00 | 0 | | | 42 | STO | | 06 |
| | 01 | 1 | | | 01 | 1 | | | 01 | 1 | | 07 |
| | 09 | 9 | | | 75 | - | | 095 207 | 02 | 2 | | 08 |
| 020 132 | 43 | RCL | | | 43 | RCL | | | 41 | GTO | | 09 |
| | 01 | 1 | | | 01 | 1 | | | 00 | 0 | | 10 |
| | 02 | 2 | | 060 172 | 09 | 9 | | | 03 | 3 | | 11 |
| | 42 | STO | | | 95 | = | | | 02 | 2 | | 12 T&T BEG |
| | 01 | 1 | | | 22 | INV | | 100 212 | | ~~~~ | | 13 |
| 025 137 | 07 | 7 | | | 39 | *PIR | | | | | | 14 |
| | 02 | 2 | | | 75 | - | | | | | | 15 AFTER E |
| | 42 | STO | | 065 177 | 09 | 9 | | | | | | 16 ~~~~~ |
| | 00 | 0 | | | 00 | 0 | | | | | | 17 00 |
| | 00 | 0 | | | 95 | = | | 105 217 | | | | 18 E0 |
| 030 142 | 46 | *LBC | | | 94 | +/- | | | | | | 19 N0 |
| | 87 | *1 | | | 42 | STO | | | | | | FLAGS |
| | 81 | HLT | | 070 182 | 01 | 1 | | | | | | 0 |
| | 46 | *LBC | | | 02 | 2 | | | | | | 1 |
| | 11 | A | | | 80 | *IF POS | | 110 222 | | | | 2 |
| 035 147 | 36 | *IND | | | 00 | 0 | | | | | | 3 |
| | 42 | STO | | | 08 | 8 | | | | | | 4 |
| | 00 | 0 | | 075 187 | 02 | 2 | | | | | | |

This program, listed in Table J-3, involves the measurement of the bearings of the desired target objects relative to the central one used for self-location from two points or observation stations whose locations are known.

The data may be acquired by sequential observation from two stations by one observer or by simultaneous observations from two stations by two observers, each transferring his coordinates, bearing from grid north of the (same) central object as determined by the main program, then measuring the relative bearing from each station and transferring it. The two observer's computed target or object point should agree quite well; accuracy and agreement depending principally on the accuracy of bearing measurements.

This function has very obvious application to forward observer's functions in real combat, and can be very valuable.

It is to be noted that the 3 programs given herein are for the Texas Instrument SR-52 which has a total of 20 addressable memories. It is somewhat doubtful if these calculations could be accomplished on the Hewlett Packard HP65 which has only half the addressable memory capacity of the SR-52. The versatile scientific calculators can be used in the field, but the need to read cards to interchange programs is a handicap. If all needed programs were stored in a non-volatile program memory, field use would be very much simplified.

2. Procedure for Self-Location Using Calculator and Observer's Sextant

The observer is provided with the following:

- A catalog book (small) having on left page a very small schematic map with descriptions of the marks or monuments and their locations in about a 6 km x 6 km region. The right page would give the UTM coordinates of these marks;
- A hand-held calculator programmed to compute his position from the UTM object coordinates and measured relative bearings; and
- An observer's sextant to measure the angles between objects.

Table J-3. Supplement #2 to Main Self-Location Program

Location (UTM coordinates) of a point observed from two known stations by relative bearings.

| | | | | | | | | | |
|---------|---------|----------|------------|--------|-----|--|--|--|--|
| ←A← | | | | | ←B← | | | | |
| (OTHER) | (OTHER) | (OTHER) | (PRESENT) | | | | | | |
| E, N | BB C | ϕ_T | θ_T | ENABLE | | | | | |

| STEP | PROCEDURE | ENTER | PRESS | DISPLAY |
|---|--|--|------------------------------------|--|
| | HAVING RUN SELF-LOCATION PROCEDURE: | | | <i>{ DO NOT TURN OFF OR USE CMS! }</i> |
| 1 | READ BOTH SIDES OF CARD | | CLR ADD READ | 0 |
| 2 | ENABLE PROGRAM | | E | L |
| 3 | ENTER E COORD OF OTHER OBS. POINT | E' | A | E' |
| 4 | ENTER N COORD OF OTHER OBS POINT | N' | A | N' |
| 5 | ENTER BEARING FROM N OF CENTRAL REF POINT AT OTHER STR (MILS) | β'_C | B | β'_C |
| 6 | ENTER ANGLE BETWEEN CENTRAL REF. & TGT POINTS AT OTHER STA. (Deg.) | ϕ'_T <div style="border: 1px solid black; padding: 2px; display: inline-block; font-size: small;">+ IF CLOCKWISE FROM REF. PT. - IF CCW</div> | C | ϕ'_T |
| 7 | ENTER ANGLE BETWEEN CENTRAL REF. & TGT. POINTS AT PRESENT STA (Deg.) | θ_T <div style="border: 1px solid black; padding: 2px; display: inline-block; font-size: small;">+ IF CLOCKWISE FROM REF. PT. - IF CCW</div> | D | θ_T |
| 8 | RUN PROGRAM | | RUN | NORTHING OF TGT. |
| 9 | READ EASTING OF TGT. | | RCL 0 5 | EASTING OF TGT. |
| 10 | RE-READ NORTHING OF TGT. | | RCL 0 6 | NORTHING OF TGT. |
| NOTE: PROGRAM RETURNS TO STEP 6 TO ALLOW NEW OBJECTS TO BE LOCATED BY MERELY ENTERING NEW SETS OF RELATIVE BEARINGS AS MEASURED AT SAME TWO STATIONS. | | | | |

Table J-3. Supplement #2 to Main Self-Location Program (cont'd)

| LOC | CODE | KEY | COMMENTS | LOC | CODE | KEY | COMMENTS | LOC | CODE | KEY | COMMENTS | LABELS |
|------------|------|------|----------|------------|------|------|----------|------------|------|------|----------|---------------|
| 000 112 | 46 | *LBL | | 67B | 81 | HLT | | | 95 | = | | A X, Y OTHER |
| | 15 | E | | | 46 | *LBL | | | 34 | TAN | | B OTHER β |
| | 09 | 9 | | 040 152 | 13 | C | | | 20 | *1/x | | C OTHER α |
| | 55 | ÷ | | | 42 | STO | | | 53 | (| | D PRES' β |
| | 01 | 1 | | | 01 | 1 | | 080 192 | 53 | (| | E |
| 005 117 | 06 | 6 | | | 06 | 6 | | | 42 | STO | | A' |
| | 00 | 0 | | | 81 | HLT | | | 00 | 0 | | B' |
| | 95 | = | | 045 157 | 46 | *LBL | | | 08 | 8 | | C' |
| | 42 | STO | | | 14 | D | | | 65 | X | | D' |
| | 01 | 1 | | | 42 | STO | | 085 197 | 43 | RCL | | E' |
| 010 122 | 00 | 0 | | | 01 | 1 | | | 00 | 0 | | REGISTERS |
| | 43 | RCL | | | 05 | 5 | | | 02 | 2 | | 00 USED |
| | 00 | 0 | | ← | 81 | HLT | | | 54 |) | | 01 Y OTHER |
| | 00 | 0 | | | 85 | + | | | 94 | ± | | 02 X OTHER |
| | 42 | STO | | | 43 | RCL | | 090 202 | 85 | + | | 03 |
| 015 127 | 01 | 1 | | | 01 | 1 | | | 53 | (| | 04 |
| | 09 | 9 | | | 02 | 2 | | | 43 | RCL | | 05 NUM, X7 |
| | 02 | 2 | | 055 167 | 65 | X | | | 01 | 1 | | 06 |
| | 42 | STO | | | 43 | RCL | | | 04 | + | | 07 |
| | 00 | 0 | | | 01 | 1 | | 095 207 | 65 | X | | 08 COTN |
| 020 132 | 00 | 0 | | | 00 | 0 | | | 43 | RCL | | 09 |
| | 46 | *LBL | | | 95 | = | | | 01 | 1 | | 10 9/160 |
| | 87 | *2' | | 060 172 | 34 | TAN | | | 69 | 9 | | 11 Y PRESENT |
| | 81 | HLT | | | 20 | *1/x | | | 54 |) | | 12 β PRESENT |
| | 46 | *LBL | | | 42 | STO | | 100 212 | 75 | - | | 13 |
| 025 137 | 11 | A | | | 01 | 1 | | | 43 | RCL | | 14 COT A |
| | 36 | *IND | | | 04 | 4 | | | 01 | 1 | | 15 β PRES'T D |
| | 42 | STO | | 065 177 | 43 | RCL | | | 01 | 1 | | 16 β OTHER C |
| | 00 | 0 | | | 01 | 1 | | | 85 | + | | 17 β OTHER B |
| | 00 | 0 | | | 07 | 7 | | 105 217 | 43 | RCL | | 18 |
| 030 142 | 58 | *dsz | | | 65 | X | | | 00 | 0 | | 19 X PRESENT |
| | 87 | *2' | | | 43 | RCL | | | 01 | 1 | | FLAGS |
| | 81 | HLT | | 070 182 | 01 | 1 | | | 54 |) | | 0 |
| | 46 | *LBL | | | 00 | 0 | | | 42 | STO | | 1 |
| | 12 | B | | | 85 | + | | 110 222 | 00 | 0 | | 2 |
| 035 147 | 42 | STO | | | 43 | RCL | | | 05 | 5 | | 3 |
| | 01 | 1 | | | 01 | 1 | | | | | | 4 |
| | 07 | 7 | | 075 187 | 06 | 6 | | | | | | |

Table J-3. Supplement #2 to Main Self-Location Program (cont'd)

| LOC | CODE | KEY | COMMENTS | LOC | CODE | KEY | COMMENTS | LOC | CODE | KEY | COMMENTS | LABELS |
|-----|------|-----|----------|-----|------|-----|----------|-----|------|-----|----------|-----------|
| 000 | 112 | 43 | RCL | | | | | | | | | A |
| | | 01 | 1 | | | | | | | | | B |
| | | 04 | 4 | | 040 | | | | | | | C |
| | | 75 | - | | 152 | | | | | | | D |
| | | 43 | RCL | | | | | | 080 | | | E |
| 005 | 117 | 60 | 0 | | | | | | 192 | | | A |
| | | 08 | 8 | | | | | | | | | B |
| | | 95 | = | | | | | | | | | C |
| | | 20 | *I/X | | | | | | | | | D |
| | | 49 | *PRD | | | | | | | | | E |
| 010 | 122 | 00 | 0 | | | | | | | | | REGISTERS |
| | | 05 | 5 | | | | | | | | | 00 |
| | | 53 | (| | | | | | | | | 01 |
| | | 43 | RCL | | | | | | | | | 02 |
| | | 00 | 0 | | | | | | | | | 03 |
| 015 | 127 | 05 | 5 | | | | | | | | | 04 |
| | | 75 | - | | | | | | | | | 05 |
| | | 43 | RCL | | | | | | | | | 06 |
| | | 01 | 1 | | | | | | | | | 07 |
| | | 04 | 9 | | | | | | | | | 08 |
| 020 | 132 | 54 |) | | | | | | | | | 09 |
| | | 65 | X | | | | | | | | | 10 |
| | | 43 | RCL | | | | | | | | | 11 |
| | | 01 | 1 | | | | | | | | | 12 |
| | | 04 | 4 | | | | | | | | | 13 |
| 025 | 137 | 95 | = | | | | | | | | | 14 |
| | | 85 | + | | | | | | | | | 15 |
| | | 43 | RCL | | | | | | | | | 16 |
| | | 01 | 1 | | | | | | | | | 17 |
| | | 01 | 1 | | | | | | | | | 18 |
| 030 | 142 | 95 | = | | | | | | | | | 19 |
| | | 42 | STO | | | | | | | | | FLAGS |
| | | 00 | 0 | | | | | | | | | 0 |
| | | 06 | 6 | | | | | | | | | 1 |
| | | 41 | GTO | | | | | | | | | 2 |
| 035 | 147 | 00 | 0 | | | | | | | | | 3 |
| | | 03 | 3 | | | | | | | | | 4 |
| | | 08 | 8 | | | | | | | | | |
| | | | END. | | | | | | | | | |

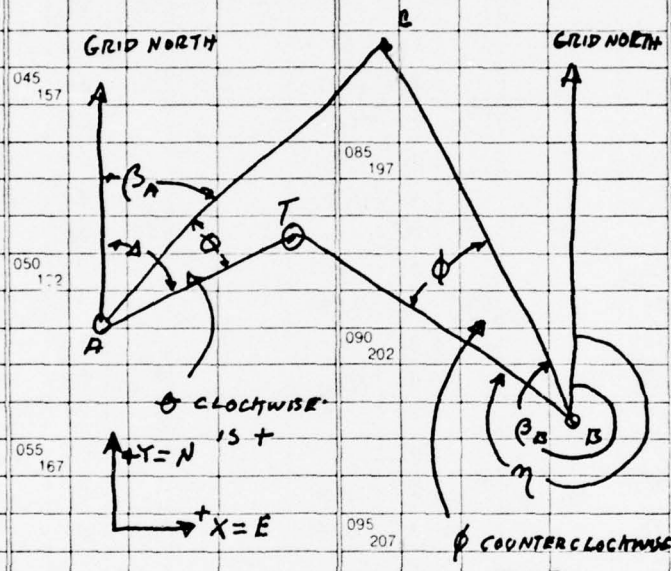

$$\Delta = \beta_A + \phi$$

$$\eta = \beta_B + \phi$$

$$X_T = \frac{Y_B - Y_A - (X_B \cot \eta - X_A \cot \Delta)}{\cot \Delta - \cot \eta}$$

$$Y_T = Y_A + (X_T - X_A) \cot \Delta$$

NOTE THAT THIS PROGRAM USES STORED DATA FROM MAIN SELF-LOCATION PROGRAM WHICH MUST BE RUN FIRST. DO NOT TURN "OFF" OR [CMS]! DO USE [CLR] BEFORE READING CARD SIDE "A".

On arrival in the region, the observer, using the catalog, will identify at least 3 of the catalogued objects. He will then enter the UTM coordinates of the three most convenient (largest relative angles and closest objects) into the calculator. Then, using the sextant, he will measure the left-most relative bearing, enter it in the calculator, then measure the right-most angle and enter it. He then operates the "program run" function and can read his present map coordinates and the grid-north bearing of the central object.

Should he now be required to laser-designate a position, given to him in UTM coordinates, he enters these target coordinates into the calculator, operates "run" and reads range (in meters) and bearing (in mils) to the target in UTM reference values. He can then either use the sextant or a compass (with proper correction for variation) to establish a line toward the target, and use either stadiametric or split-image rangefinding techniques to establish the target-point location.

The observer can leave the object coordinates stored in the computer as he moves about within a region as long as he can still see the same objects and as long as their left-right order does not change and he merely re-enters new observed angles to find his new positions. He then maintains a given position of advantage. He can designate different target areas by merely re-entering new target coordinates and reading new range and bearing data. This is done very quickly.

The above describes the operation using a special, dedicated calculator with non-volatile memory. The temporary, experimental use of the SR-52 calculator having volatile memory will be slightly more complex. This is because using the supplementary target location program by reading the magnetic card for it destroys the initial position-finding program memory while preserving memory of present-position data. (Program memory is changed, but not data memory.) Thus, if the observer moves to a new position, using the SR-52, he must re-read his position-finding card, and re-enter the object coordinate data as if he had just arrived in the region. This is quickly done, however, but it is less convenient than would be the case with a special computer with permanently stored programs.

A fact which has long been recognized in use of the geometric principles on which this technique is based is that there is one geometric situation in which it is "impossible" to get a "fix". This is known as a "revolver", and occurs when the observer's location lies on the circle through the three observed points.

In this case, any point on that circle is a solution. There is no unique solution available.

The calculator doesn't know this, however, and experiments show it will give an answer somewhere in the region, but not very precise. It is easy to avoid this situation provided there are more than three known objects observable. Note further that because of the extreme accuracy of the calculator, the situation can be avoided, if it occurs, by moving to a new location somewhat displaced from the first if a revolver is suspected.

The problem can be avoided entirely if the objects chosen are in a straight line (or nearly so) or if the arc through them is convex toward the observer. It would be helpful if, for a given region, the object catalog "maps" have circular arcs drawn through objects which may be troublesome. This is not a serious problem with the computer precision available. Even a small displacement of the observer from the critical circle is sufficient to get an accurate fix provided angle measurements are made carefully.

3. Range Preparation

a. Practical Aspects

In a real European battlefield, almost inevitably many accurately surveyed features are always available within 2 to 3 km.*

The monument technique is well known, and has been used by U.S. Coast and Geodetic Survey (USC&GS) and other agencies for many years. The markers are distinctively shaped, usually painted white, and mounted on posts. They are commonly made of wooden slats for minimum wind forces. Typical shapes are spheres (crossed circles), pyramids in both normal and inverted forms, cubes, and combinations to give a distinctive form not likely to be confused (see Figure J-3). Such a prepared, surveyed range is not difficult or expensive to prepare to about one meter accuracy.

* Precision survey for artillery purposes began in Europe in Napoleon's time, and has been continually updated by the French and Germans in the Franco-Prussian WWI and WWII periods. The entire file is now in the possession of the Army Map Service.

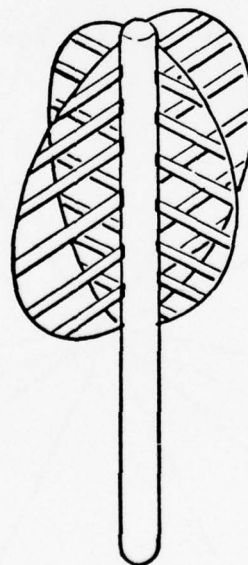
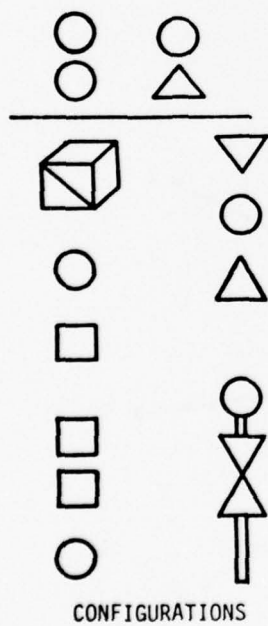
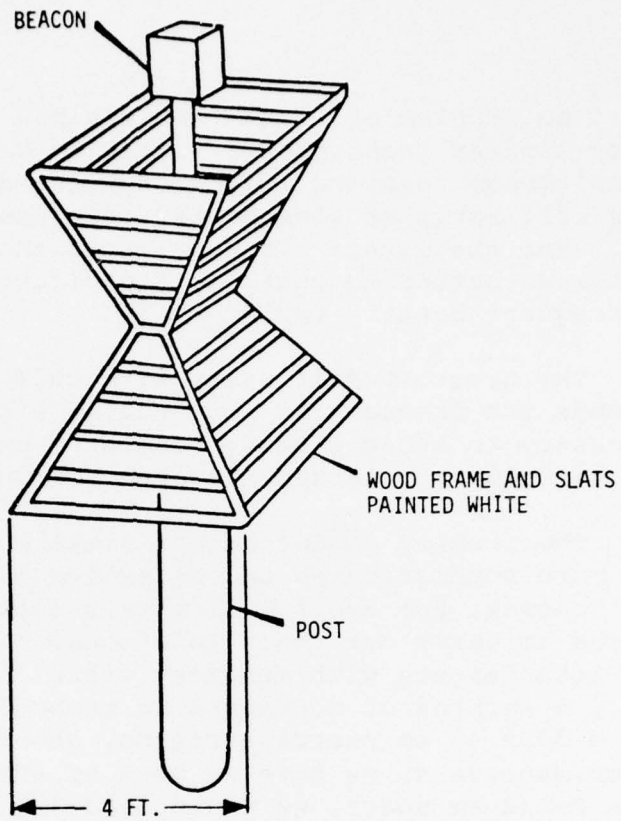

P3229

Figure J-3. Monument Configurations (typical)

The problem of night-time visible markers is different, but very similar techniques familiar to Mariners can be employed. Small multibeam rotating flashers giving distinctive morse-code symbols will serve at each marker (for example, k, — · — , D, — · · and the like). In many areas these could be powered from storage batteries charged in daylight by a solar panel to avoid frequent battery replacement.

The greatest difficulty with this scheme is weather. If low clouds are frequent in a mountainous or hilly region, it may be necessary to avoid placing monuments on peaks. If poor visibility is frequent, larger numbers of monuments may be needed.

The problem of deliberate smoke must also be considered. In the more sophisticated and effective laser weapon effects simulation schemes, the users will always seek relatively elevated positions to carry out their functions. This, to some degree avoids interference with monument visibility from low-level smoke; however, a surplus of monuments is probably desirable. If we envision a 30 x 40 km exercise region, about half of which is accessible for maneuvers, we have an area of 600 km². If monuments average 2-1/2 km apart, we would need $\frac{600}{2.5^2} = 96$ monuments in the region (see Figure J-4).

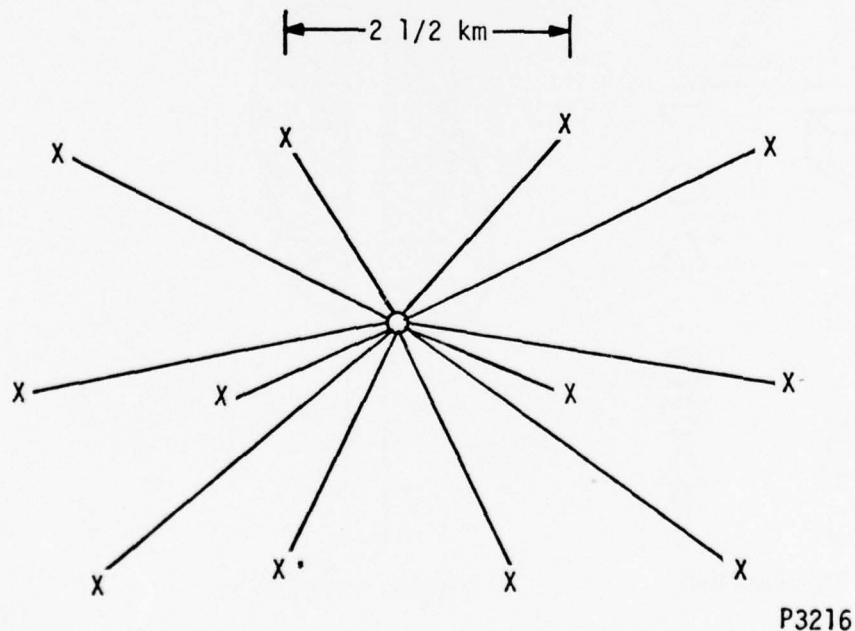

Figure J-4. Example of Range Monument Distribution

This may be an overestimate of the needs. A particular theater would need study to determine the real requirements. Accuracy is enhanced by using closer monuments and comparatively large relative bearing angles. The error in position should average no more than 0.002 of the mean monument distance which is eminently satisfactory for weapon effects simulation purposes.

b. Rotating Beacons/Power Requirement for Night Position Finding

As noted elsewhere, the passive monuments will serve adequately for daytime position-finding, but of course they are ineffective in hours of darkness.

A worst case requirement for beacon brightness (illuminance at a distance) is that of sky background at about the point where the silhouette contrast of the passive monument against dawn or dusk sky becomes inadequate. This may be taken as at about 1/2 hr after sunset at a sky luminance of approximately 5×10^{-1} cd/m² (ref RCA Hdbk., Figure 6-10). At this point, the threshold illuminance of a monochromatic point source for human eye detection is about 10^{-7} lm/m² (ref Figure 5-3, RCA Hdbk.). Allowing 6 to 7 db of margin, such a source should have then 5×10^{-7} lm/m².

A rotating beacon's optics would be about as depicted in Figure J-5(a). The lamp can be silvered on its back hemisphere to give 180° of coded illumination and a luminance increase factor of ≈ 1.5 . The gain over irradiance into 4π steradians for the 5° beam is then, $1.5 \times \epsilon/5^\circ$ where ϵ is the intercept angle of the Fresnel lenses in the vertical plane. For f:l lens see Figure J-5(b).

The relative output of small tungsten filament bulbs is about 7.9 lm/W of input power (about 2400°k). (Ref RCA Hdbk Figure 6-16.)

Now, if we wish, in clear conditions to see this extreme case with the above noted safety margin figure of 5×10^{-7} lm/m² at 3.5 km,

$$1 \text{ m}^2 \text{ at } 3.5 \text{ km subtends } \Omega = \frac{1}{(3500)^2} = 8.16 \times 10^{-8} \text{ steradians}$$

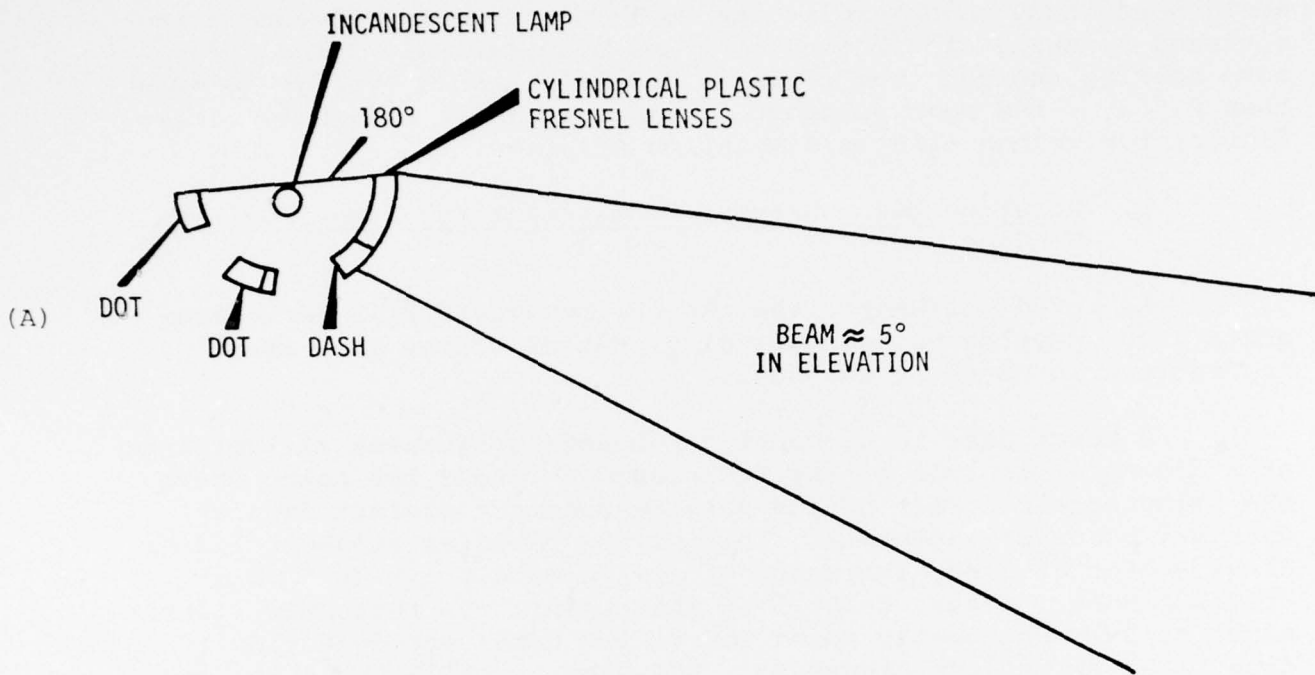

P3230

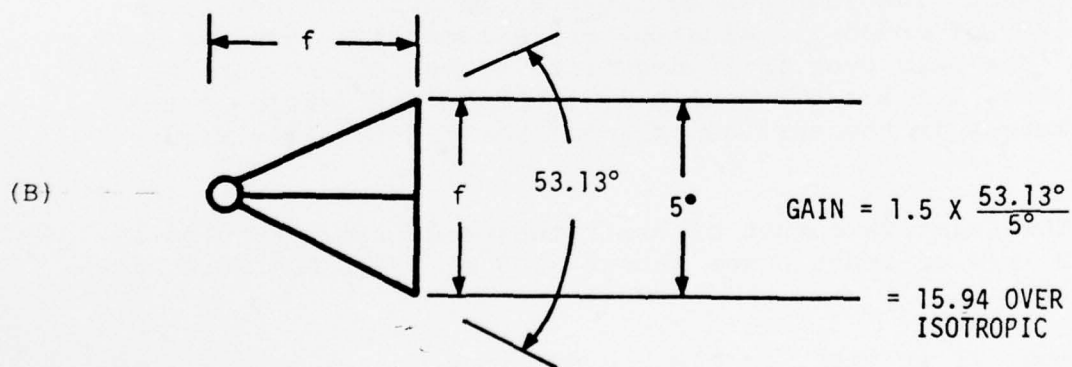

P3231

Figure J-5. Rotating Beacon's Optics

and the bulb radiates into 4π steradian with an output gain of 15.94 with reflector and Fresnel lens.

The bulb's output is 7.9 lm/W , where W is the input power, so that it radiates a luminance through the optics of

$$\frac{7.9 \text{ W}}{4\pi} \times 15.94 = 10.02 \text{ W lm/ster}$$

and at 3.5 km, we would have

$$10.02 \text{ W} \times 8.16 \times 10^{-8} = 8.18 \times 10^{-7} \text{ lm/m}^2$$

and we require $5 \times 10^{-7} \text{ lm/m}^2$. Thus, a 1-W bulb should serve adequately (input power). This is with a 6 to 7 db margin over the 1/2 hr after sunset sky.

We have considered here the whole spectrum. If we allow the use of blue-green, yellow-orange, and red colored* beacons, (Ref Figure 5-9, RCA Hdbk.) a factor of about 3 should be added for the relative luminous efficiency for the red (worst case) beacon. Thus, a 3-W input bulb is needed. At 12V, this is a 250 mA drain on the source (see Figure J-6). The source will be very bright in the hours of total darkness, and the current drain can, on the average, be reduced to 200 mA (by solar cell control) over the whole period of darkness, taken conservatively as 13-1/2 hr average/24 hr or 94.5 hr/week. Thus, the weekly ampere-hour requirement for the lamp is $94.5 \times 0.20 = 18.9$ ampere hours/week. If we allow a 1-1/2 watt drain for the drive motor, this is increased to about 40 amp-hrs/week conservatively. A solar panel of about 6- x 12-in. (silicon cells) at Washington, D.C. could furnish the energy to keep a battery charged under these conditions.

4. Design Scheme for Observer's Sextant

a. Discussion

The device is called a sextant even though as conceived it will measure angles only somewhat more than 90° , and deliberately, no very small angles. It is intended to measure angles -- in the horizontal plane -- between objects of known locations which generally may be well above or slightly below the horizon as viewed.

* Really "tinted": we anticipate use of a dichroic mirror in the sextant and need a useful component of white. The color is for visual identification only.

ELEVATION OF BEACON OPTICS

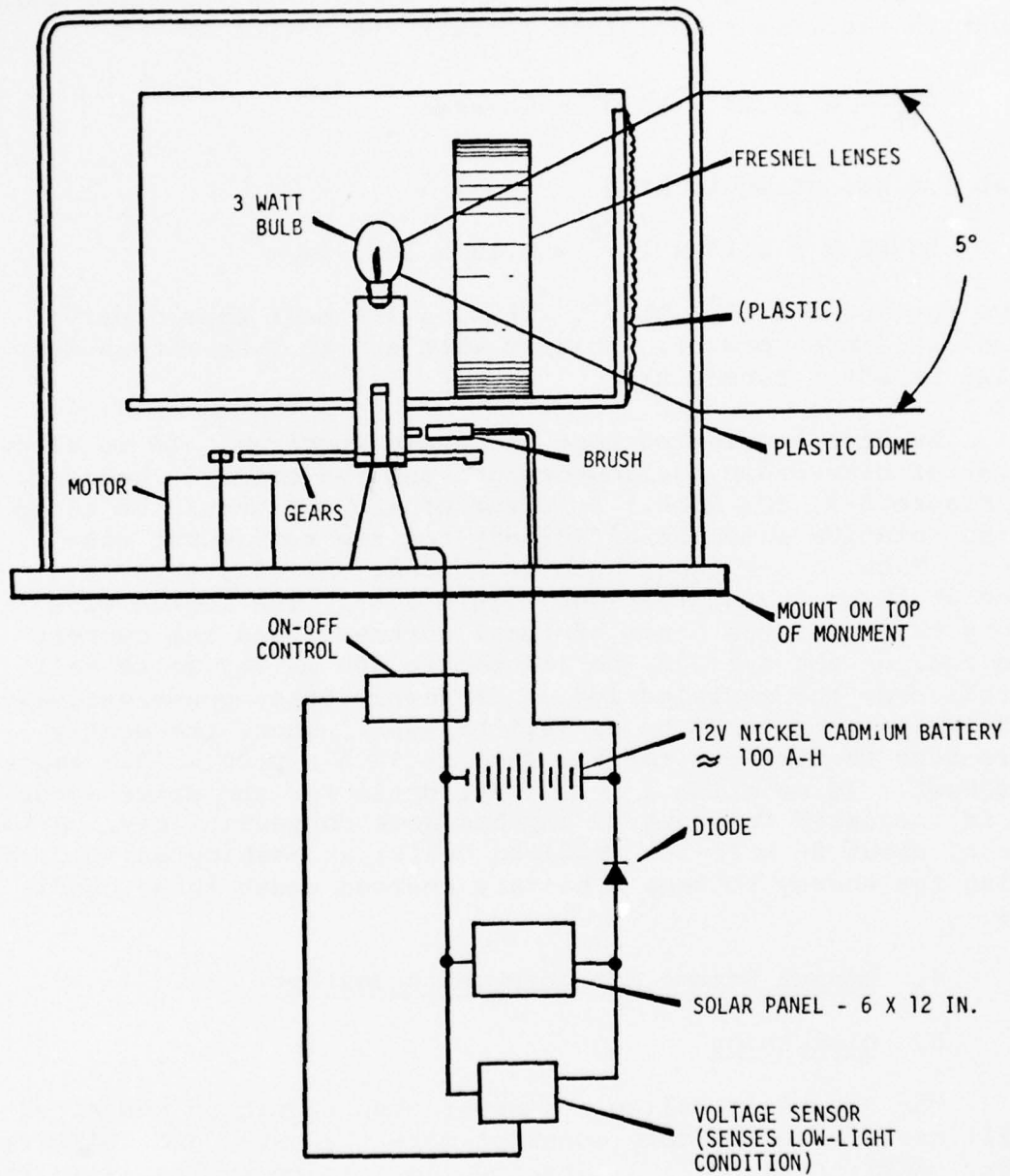

P3232

Figure J-6. Range Rotating Beacon

The use of an ordinary sextant or a "surveyor's sextant" has several objections. They are as follows:

- The use of a mirror edge is somewhat troublesome because only 1/2 of each of two scenes appear to the eye (with slight overlap because of the proximity of the horizon mirror). The "trick" of reading angles with a sextant is readily learned, but nevertheless it is troublesome.
- Generally, the objects used will be well above the horizon, yet the angle must be measured in a horizontal plane to avoid errors which may otherwise be $\approx \pm 1/2^\circ$.
- The objects may vary considerably in angle above/below the horizon, so that means must be provided to allow the measurement to be made conveniently in the horizontal plane without loss of one or the other image.

Thus, a rather special device is needed for the intended purpose -- that is, a device with the image stability of a sextant to allow hand-holding, yet without the horizontally split image and with large freedom of the effective vertical angle and a well-adjusted horizontal measurement plane. The latter implies a damped pendulous optical system independent of the hand-holds and eyecup. The first implies sextant-like optical geometry, and the avoidance of a split image implies, with sextant geometry, the use of a slitted mirror with aperture sufficient to afford an adequate image, and very close to the eye pupil. There will be no lenses in such a system -- merely two mirrors.

The device, as depicted in Figure J-7, can be thought of as an inverted sextant (or octant) in which the movable mirror is closest to the eye. The measured angle, θ is represented by $\pm 1/2 \theta$ movement of the mirror from null.

b. Measurement of Relative Bearings in a Horizontal Plane

The present problem of position-finding by relative bearings on three objects of known positions ashore in non-level terrain differs significantly from the usual ship-pilotage problem afloat, using a sextant to measure the angles. Afloat, virtually all objects and the observer are close to the level of the sea and the vertical angles are insignificantly small. Ashore, in typical tactical exercise terrain or in real tactical warfare, this is generally not the case. Vertical angles from the horizontal to the objects viewed may be as large as $+20^\circ$ to -10° (this is from a study of maps of Germany near the Mosel River).

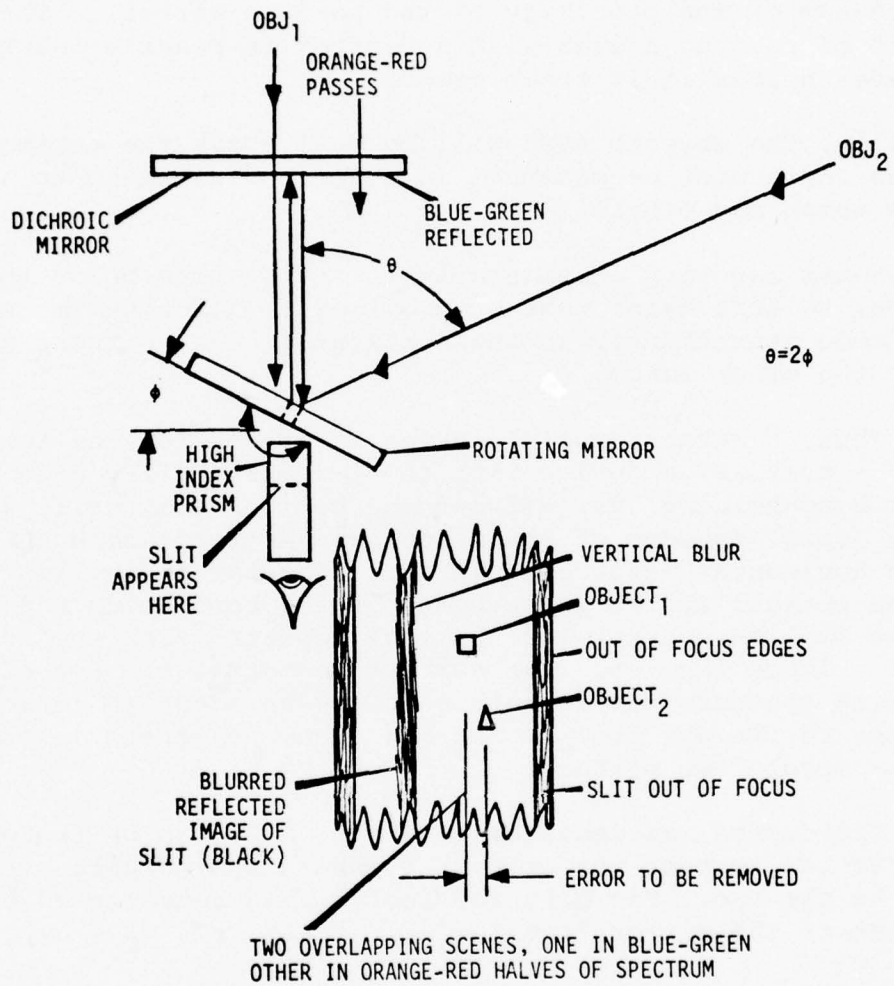

P3233

Figure J-7. Plan of Optics and Nature of View Through Slit

If θ^1 is the measured relative bearing angle measured in a plane elevated by an angle ϕ above the horizontal, then the true angle θ is given by:

$$\tan \left(\frac{\theta}{2} \right) = \frac{\tan \frac{\theta^1}{2}}{\cos \phi}$$

Table J-4 illustrates examples of errors. It may be seen that even a 5° error in the plane of measurement is quite objectionable for accurate position locations, while a 1° error has an effect less than the probable error of measurement with a sextant. Thus, it is essential that the instrument provide for measurement of the angle in a level plane. To do this, the final angular adjustment of the mirror must be done with the optical system suspended as a (damped) pendulum.

Table J-4. Bearing Angle Errors for Elevations of ϕ

| θ^1 | $\phi=20^\circ$ | $\phi=15^\circ$ | $\phi=10^\circ$ | $\phi=5^\circ$ | $\phi=1^\circ$ |
|------------|-----------------|-----------------|-----------------|----------------|----------------|
| 90° | $+3.56^\circ$ | 1.986° | 0.877° | 0.218° | 0.009° |
| 60° | $+3.13^\circ$ | 1.735° | 0.7625° | 0.189° | 0.0076° |
| 45° | $+2.575^\circ$ | 1.422° | 0.624° | 0.154° | 0.0062° |
| 30° | $+1.830^\circ$ | 1.008° | 0.441° | 0.109° | 0.0044° |

Note: The true angles are larger than the measured angles.

Another factor engendered by the elevations of the viewed objects is the need to have means for observing objects elevated well above the level plane, and somewhat below it simultaneously.

A study of various means for solving the vertical-angle problem reveals that a decisive choice in terms of ease of use of the instrument and avoidance of mistakes is to use a dichroic beam-splitter plate instead of a "horizon mirror" as the fixed forward element of the optics. This type of mirror is transparent to half of the spectrum (say to orange-yellow through red) and reflects the other half of the spectrum (orange-yellow through blue appearing greenish). This will allow the directly viewed scene observed through the slitted (rotating) mirror to appear in an orange-yellow predominant color and the reflected scene in greenish color.

Even so, the confused double-image may be somewhat troublesome in "finding" the second (reflected) object. Experiment shows that this difficulty is entirely avoided if the direct view is temporarily blocked by a dark-slide. Once having "found" and approximately centered the reflected object, the dark-slide (or flip cover) can be opened and precision adjustment of one object directly above, coincidental or below the other can proceed. This is a very sensitive measurement capable of very good accuracy. The initial adjustments can be made with the pendulous mechanism "caged", but final adjustment should proceed with the system pendulous to assure measurement in a level plane.

One further optical "trick" should be mentioned. Ideally, the eye should be very close to the slit in the rotatable mirror. This is not very easy because of the angle through which the mirror must rotate and the presence of the shaft bearings and housing below the mirror. If we introduce a rectangular prism of barium flint glass (index of refraction about 1.66), which is not much wider than the slit and blackened on all but the entrance and exit surfaces, the eye can be moved back appreciably, yet the slit will appear to be quite close to the eye. The apparent thickness of the prism is about 60% of its actual length. This allows us to get brow-and-cheek clearance with a good angle of view through the slit. For a 3.5-mm slit, the prism should be about 6-mm wide, but rather high to allow the eye to have reasonable vertical scope (say about 1 in.).

To achieve good, repeatable accuracy, the worm and wheel should be of good quality with the latter of the spring-loaded antibacklash type. For the same reason, both worm and wheel should be suspended in precision ball bearings with adequate distance between centers and with a "preloaded pair" at one end of each shaft to remove any axial "shake".

The resulting mechanism will have inadequate frictional restraint without a "brake". An ideal solution to this is to use a brake "shoe" of "Delrin" bearing under spring load on the inside of the drum dial. This remarkable material is totally devoid of "stiction". The friction coefficients for low-speed, low pressure dynamic and static conditions are identical. This allows very easy, yet stable adjustment of mirror angle with precision.

To avoid thermal errors introduced by differences of thermal coefficient of expansion between the points where mirror support bearings and the preloaded pair establishing axial position of the worm are located, this part, at least, of the framework structure should be of the same material as the worm-wheel, worm, and shaft -- stainless steel of the same type.

After assembly, the vernier of the dial can be set at null easily by observing both images of a distant slender object coincident at zero degrees.

The largest residual errors will result from any imprecise centering of the worm-wheel on its shaft and of the worm on its shaft. The vernier can be read to 0.01° , but the measurement accuracy, considering human factors and inevitable mechanical inaccuracies, should not be considered to be better than $\pm 0.03^{\circ}$ or about ± 2 min of arc. This is normal for sextants.

A "trick" which can be used to assure best accuracy, given the time, is to measure the angle repeatedly with the observed and residual error (visual) first in one direction, then the other, and then to average the readings. This leaves little appreciable error other than instrument error.

c. Concept for Improved Observer's Sextant

The foregoing concept for an observer's sextant has two factors which are somewhat inconvenient.

- The need to observe the images through a slit in the mirror with the image of the slit in the field; and
- The need to use a high index rectangular prism to attain an effective close-approach of the eye to the slit - somewhat limited in effect.

Experiments with a cube type beamsplitter and mirror show that a superior design concept for the sextant optics is as shown in Figure J-8 (see Figures J-9 and J-10 for improved sextant concept illustrations). Here the beamsplitter cube is inclined at 22.5° to the direct line-of-sight to the right-most object and a mirror is mounted on a rotation axis offset 22.5° from the midpoint of the right face of the beamsplitter. With the mirror in the position shown, the direct and reflected images of a distant object

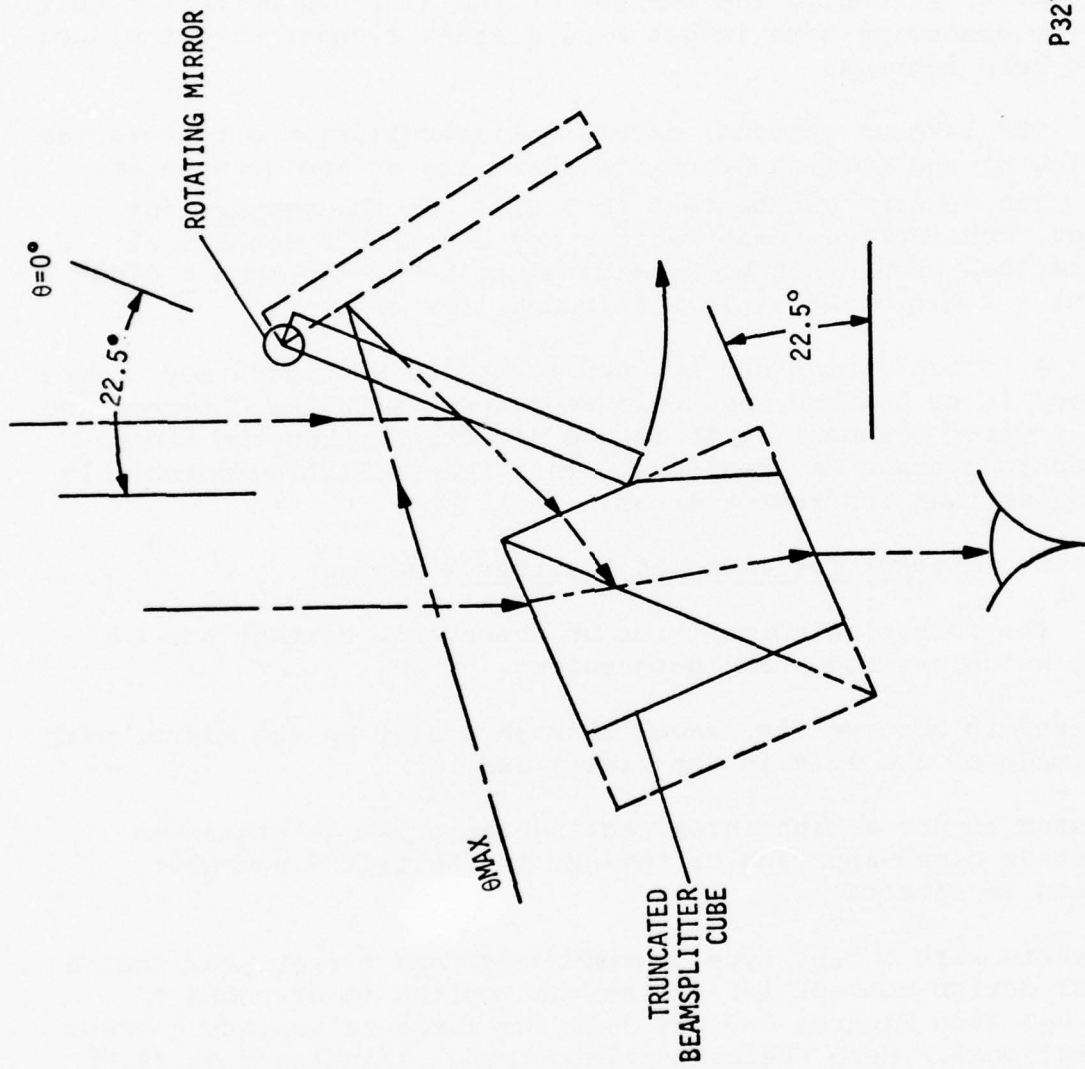

P3212

Figure J-8. Improved Sextant Optics

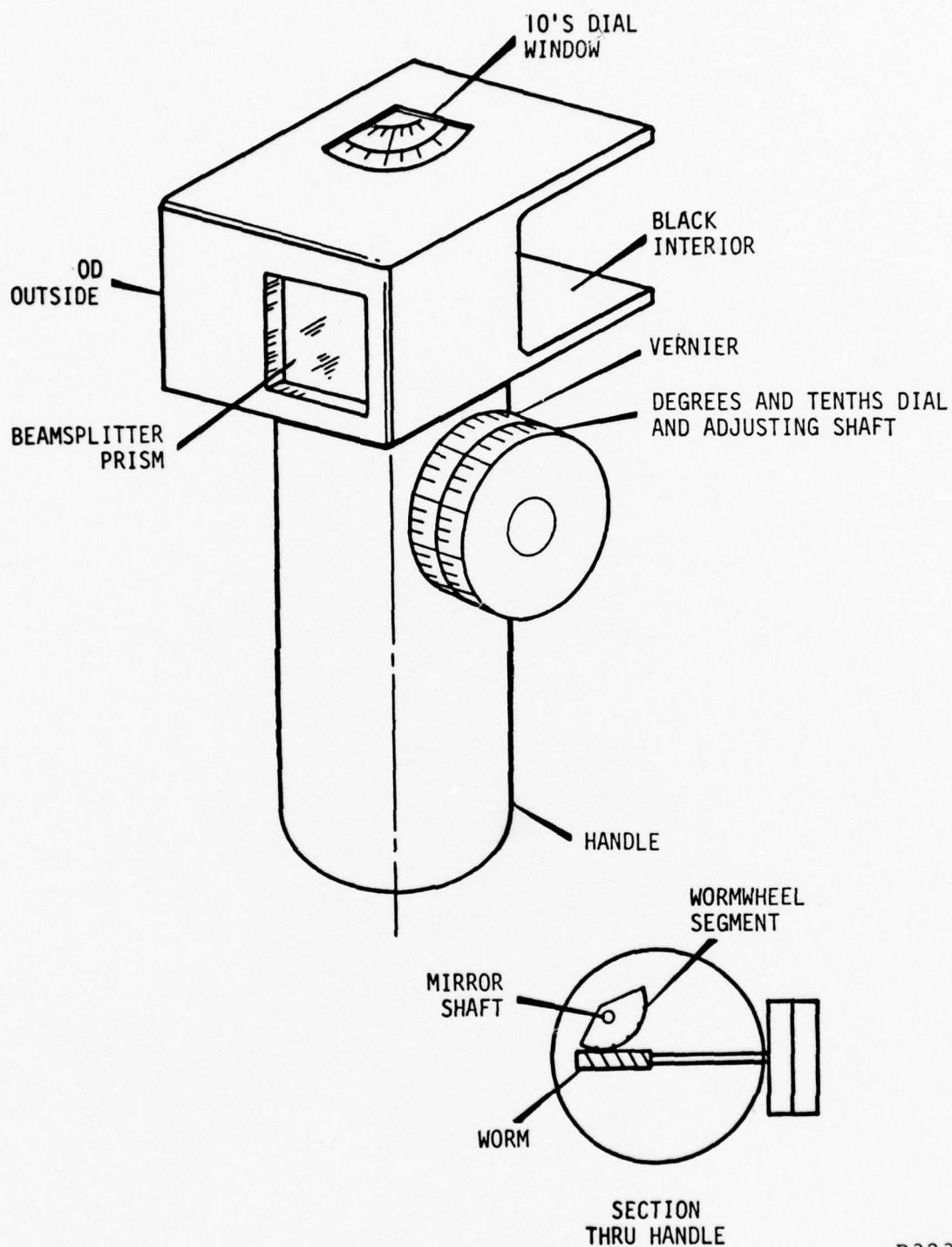

P3237

Figure J-9. Improved Observer's Sextant Concept

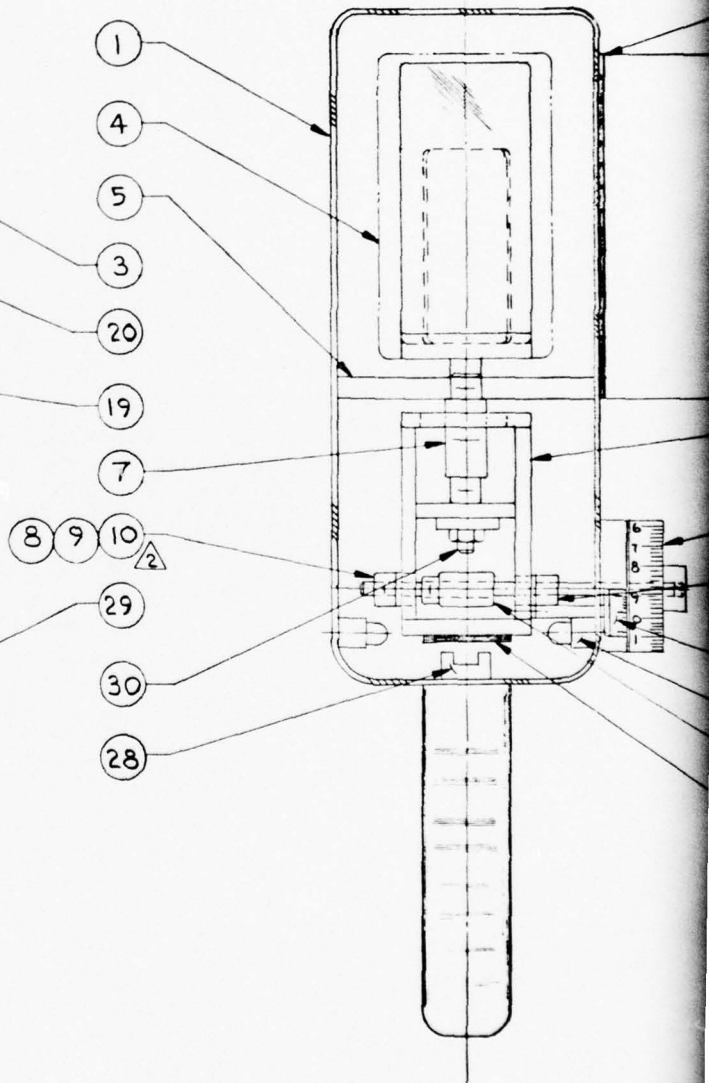
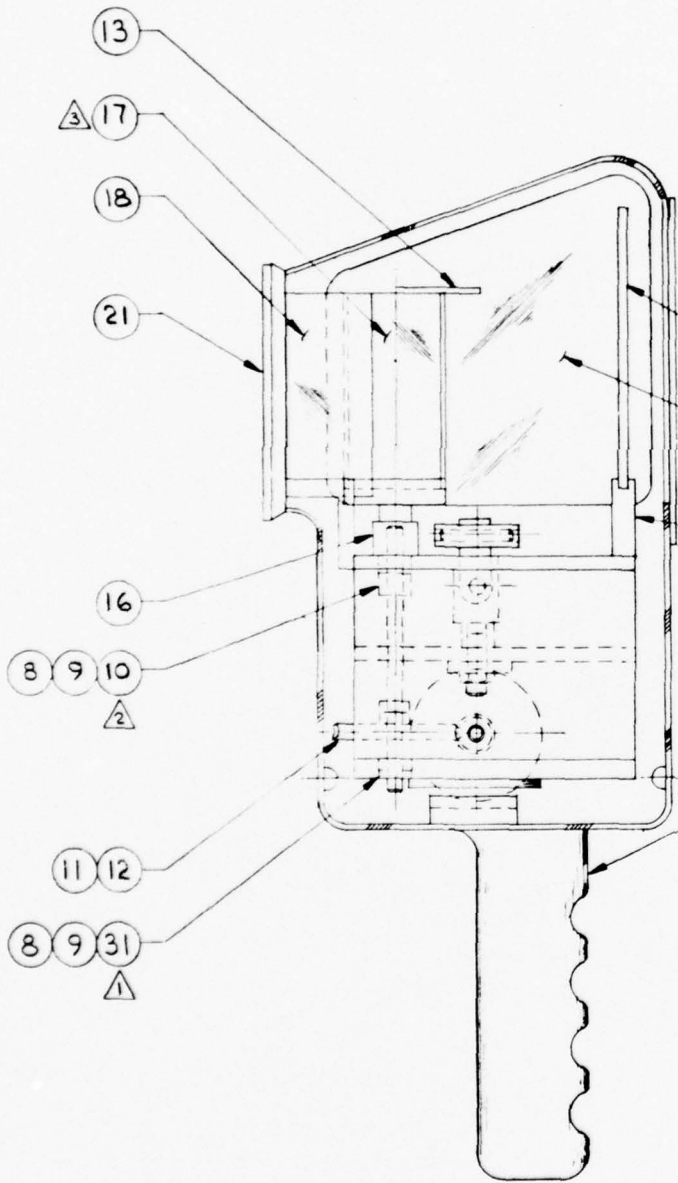
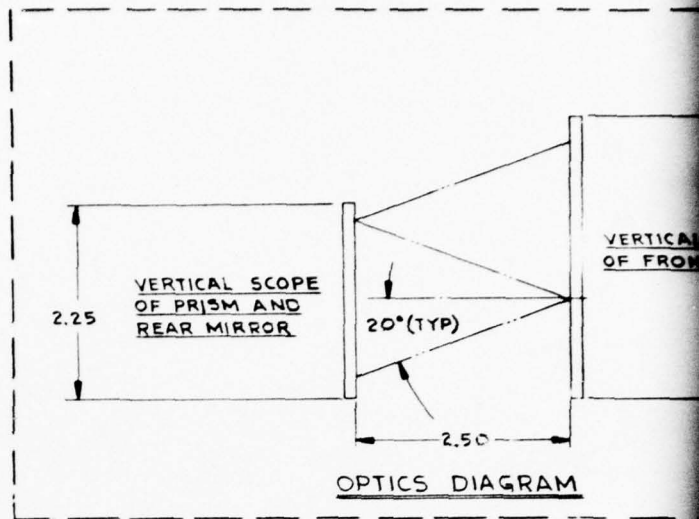
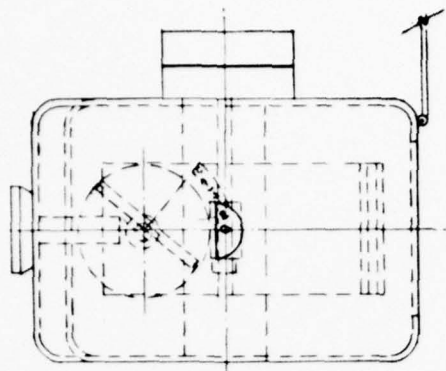

Figure J-10. Observe

are coincident (0°). Rotating the mirror as shown permits measurement of angles (twice the mirror rotation angle) to about 120° before the reflection of the cube interferes excessively.

With a reasonably tall beamsplitter and mirror, a large vertical field of view is available, and the eye can be held quite close to the cube.

The cube can be truncated as shown to save weight and space. The unused surfaces of the beamsplitter should be blackened with a lacquer of index close to that of the glass to avoid loss of image contrast due to internal reflections and entrance of unwanted light. A one inch cube should suffice, allowing a quite small and light sextant to be produced. Accuracy will depend entirely on the quality of bearings and worm and wheel used to drive the mirror.

5. Field Records and Forms

Because it has been noted as essential that fielded simulation personnel maintain records of their actions, and because the actual operations of position-finding and object and target location will be facilitated, tentative forms for the use of fielded personnel have been devised as shown herewith.

These forms will facilitate the entry of data into the calculator and laser weapon-effects simulator, and the recording of position and bearing data. In effect, they are foreshortened instructions, a procedural "roadmap" and in use will serve as records of simulated fires, positions, and an accumulating record of accurate locations of recognizable location for individuals' quick use to foreshorten simulation functions.

The forms should be bound in spiral binders in about 4" x 6" format so as to easily fit in pockets. A ballpoint pen and penlight will be useful adjuncts.

It is noted that the fixed-object data on the self-location form (Figure J-11) can usually be pre-entered in the calculator so that initial self-location will usually require only entry of the two measured bearings to find an initial primary position fix.

Given time in which no simulations are required, operators can then observe a number of relative bearings between the central object and observed, recognizable and accessible favorable vantage points.

SELF LOCATION: CARD NO. 1
E-ENABLE

| REFERENCE OBJECTS | | | |
|-------------------|---------|------------|----|
| LEFT-MOST | CENTRAL | RIGHT-MOST | |
| E | A1 E | A3 E | A5 |
| N | A2 N | A4 N | A6 |

| | | | |
|----------------|---|----------------|---|
| B _L | B | B _R | C |
|----------------|---|----------------|---|

| | | | |
|----------------|--------|-----------------|--------|
| E ₀ | RCL 00 | CENTRAL BEARING | RCL 12 |
| N ₀ | RCL 11 | STATION NO. | MILS |

| OBJECTS OBSERVED | CENTRAL RELATIVE BEARING, ° |
|------------------|-----------------------------|
| | |
| | |
| | |
| | |
| | |
| | |
| | |

CLOCKWISE +, CCW -

FIRST LOCATION THIS PAGE

DATE _____

SIGNATURE _____

| | | | |
|----------------|---|----------------|---|
| B _L | B | B _R | C |
|----------------|---|----------------|---|

| | | | |
|----------------|--------|-----------------|--------|
| E ₀ | RCL 00 | CENTRAL BEARING | RCL 12 |
| N ₀ | RCL 11 | STATION NO. | |

| OBJECTS OBSERVED | CENTRAL RELATIVE BEARING, ° |
|------------------|-----------------------------|
| | |
| | |
| | |
| | |
| | |
| | |
| | |

CLOCKWISE +, CCW -

SECOND LOCATION THIS PAGE

(OBVERSE)

P3234

Figure J-11. Self Location: Card #1
E-Enable

Upon moving to a second position from which these points are observable, the form for and use of the third program card (Figure J-13) and bearing measurement permits these points to be accurately located in grid coordinates for possible future use as laser or visual cue operating points. The second program card and form (Figure J-12) is used for range and bearing calculation from present position to required weapon-effect central points for weapon simulation by laser operators and visual cuers. It also provides for entry of data as received from the SNCS for laser settings.

After some experience and accumulation of position data, the full complement of these programs may seldom need to be used by an operator familiar with the ground.

This indicates that several days of familiarization and data taking for field personnel would be very useful as a preliminary to actual training exercises.

The forms have been devised for use with the SR-52 programs. Simplified forms and procedures would result from use of the specialized calculator with non-volatile memory as discussed elsewhere in this appendix.

6. Conclusion

The ultimate calculator should be set up to use entered angles in mils and the "observer's sextant" gear, worm and scales revised to suit. However, the SR-52 inputs are necessarily in degrees with the limitation on program length, and the "observer's sextant" should initially be set-up as noted. The device is small and light enough to be carried in a belt holster.

It is believed that a concept-verification program is needed prior to the specifications of new specialized calculators and sextants. Since these will ultimately find their primary application in real artillery and observer/target location functions, practical experience with prototypes is needed first, and the SR-52 with oversize battery-pack can fulfill this purpose quite well. Cards for the SR-52 can be reproduced from existing cards with an SR-52, or can be keyed-in using the documents herein and then recorded.

OBJECT LOCATION CARD NO. 3
 E-ENABLE
 (AFTER RUNNING PROG NO. 1)
 (BOTH SIDES OF CARD)

| |
|-------------|
| STATION NO. |
|-------------|

| |
|---------------|
| OTHER STATION |
|---------------|

DATE _____

SIGNATURE _____

| | | | |
|--------------------|-----|-----|----|
| E _{OTHER} | --- | --- | A1 |
| N _{OTHER} | --- | --- | A2 |

| | |
|-----------------|------|
| OTHER | B |
| CENTRAL BEARING | MILS |

| | | | | | |
|----|--------|----------------------|-------|------------------|--------|
| -A | OBJECT | B _{OTHER} | C DEG | E _{OBJ} | RCL 05 |
| | | B _{PRESENT} | D DEG | N _{OBJ} | RCL 06 |
| -B | OBJECT | B _{OTHER} | C DEG | E _{OBJ} | RCL 05 |
| | | B _{PRESENT} | D DEG | N _{OBJ} | RCL 06 |
| -C | OBJECT | B _{OTHER} | C DEG | E _{OBJ} | RCL 05 |
| | | B _{PRESENT} | D DEG | N _{OBJ} | RCL 06 |
| -D | OBJECT | B _{OTHER} | C DEG | E _{OBJ} | RCL 05 |
| | | B _{PRESENT} | D DEG | N _{OBJ} | RCL 06 |
| -E | OBJECT | B _{OTHER} | C DEG | E _{OBJ} | RCL 05 |
| | | B _{PRESENT} | D DEG | N _{OBJ} | RCL 06 |

COMMENTS

(OBVERSE) P3236
 Figure J-13. Object Location: Card #3
 E-Enable

APPENDIX K

SYSTEM "X"

SYSTEM "X"

A. GENERAL DISCUSSION

Late in the study program, after the use of the grenade-launcher visual cue device had become established as the best approach, a concept of using the visual cue device as a kill-designation signal initiator was conceived. This concept is based upon making a measurement at each target of the sonic overpressure from the visual-cue burst. In this scheme, the height of burst and position must be accurately controlled by the cuer. The sonic overpressure is a simple function of height and horizontal radius from the burst point, and as such is a measure of lethality at a given point on the ground when associated with a weapon-code signal transmitted separately from a very short-range RF transmitter immediately after the cue burst and received by a simple receiver on each target. Both adequate overpressure (some lethality) and the weapon identity code must be received by a target in a very short interval to effect a kill cue which can be further modified by a P_k analyzer which uses the magnitude of overpressure and weapon identity code and target type as inputs.

At first, this scheme appeared extremely attractive, but its application with any confidence depends upon using an overpressure sensor which is not also a microphone--that is, a unit that is sensitive to small overpressure pulses, but not to mechanical shocks or general white noise. Note that there is no real way of restricting the radius of the accompanying RF signal resulting in many inevitable false signals unless the overpressure sensor problem is solved.

B. OTHER PROGRAMS

Efforts on another in-house program to solve the overpressure sensor problem have met with no success. The System "X" approach is therefore put aside as currently infeasible. Nevertheless, if such a transducer ever becomes available, the approach has some merit and might be considered for other purposes.

APPENDIX L

POSITION FINDING SYSTEMS

POSITION FINDING SYSTEMS

A. ELECTRONIC POSITION/LOCATING SYSTEMS

1. Range Measuring System

The Range Measuring System (RMS) uses the multilateration technique for determining the position of potential targets. The system components of the RMS are shown in Figure L-1.

The RMS measures the ranges from a detected object to a number of fixed stations at known locations.

The range information is placed into a computer which computes the position of the target.

The target is equipped with a transponder (called a B-unit) that communicates with the fixed stations (A-Stations) to obtain an accurate range figure.

B-Units may be positioned on soldiers, mobile vehicles (tanks, trucks, and the like), aircraft, or marine craft. Each B-Unit transponder has its own unique address and transmits only when individually interrogated.

The host computer (C-Station) controls the RMS by automatically interrogating the B-units of interest and, in turn, computes their positions from the accumulated data.

Position data may be printed out on line printer units and/or presented graphically on the system's display subsystem for immediate analysis.

The Basic components of the RMS as shown in Figure L-1 are defined as follows:

- A-Station -- Semi-mobile solar powered stations, either ground or vehicle mounted. These stations are used to interrogate the B-units for position data. They are unattended and do not require extensive site preparation.
- B-Units -- These are transponder devices carried by the mobile elements in the field. They are used to determine position and provide a data communications link between participants of the exercise.

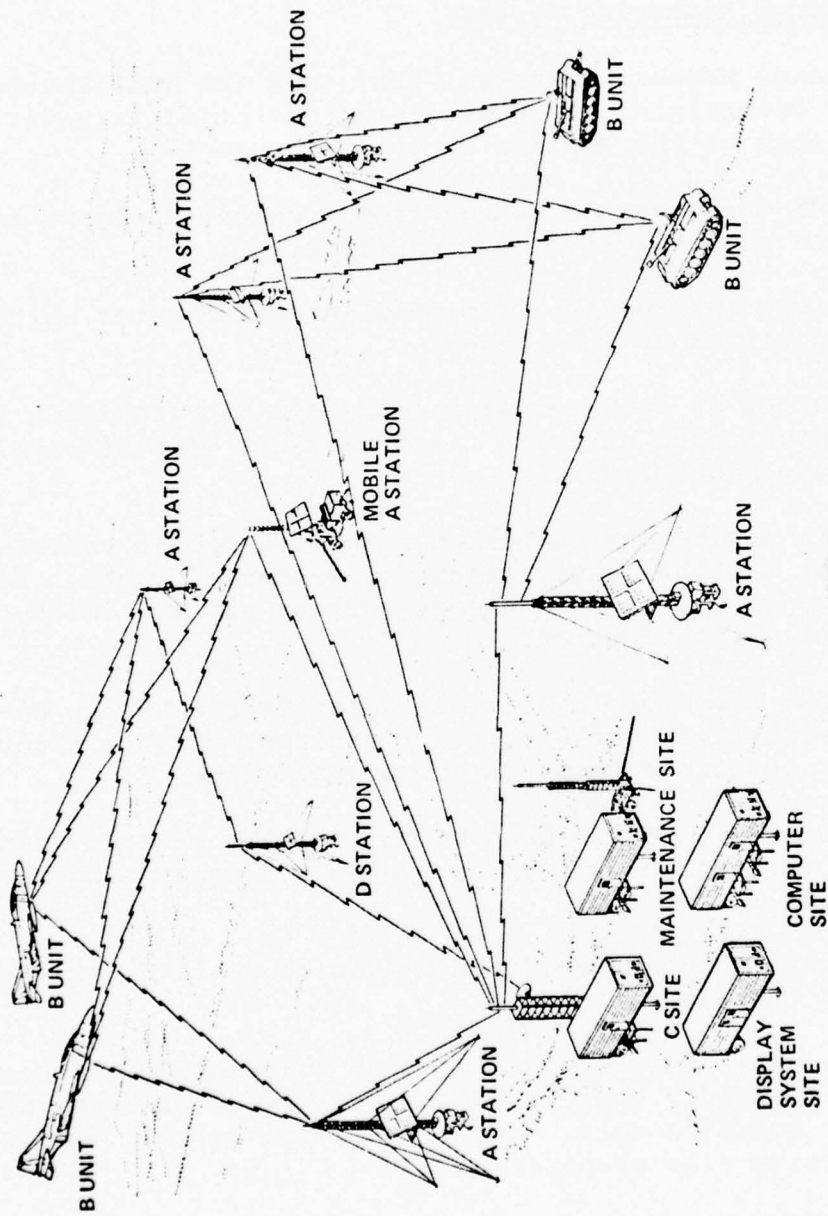

P3241

Figure L-1. Range Measuring System Components

- C-Station -- Provides the control and communications link between the various participants of the RMS.
- D-Station -- Semi-mobile solar powered stations, either ground or vehicle mounted. These stations function as relay stations to extend the range capability between the A-Stations and the C-Stations.

The operational advantages of the RMS configuration are that the system may be rapidly relocated and set-up. It offers a versatile software package that requires minimum or no modification to accommodate a wide variety of operational testing and evaluation tasks. The RMS also requires little manpower to operate the system. The operating range extends to 64km with an accuracy of 25 to 30m. One disadvantage of this system is the cost. The following is an example of a RMS presently used at Hunter-Liggett with relative equipment costs.

- One C-unit (master control station), van mounted, costs 100K plus dollars, not counting required computer.
- 64 B-units at 22K/unit.
- 14 A-units at 45K/unit.
- 2 D-units at 60K/unit.

2. Position Location Reporting System (PLRS)

The PLRS Communicating with a master unit is capable of determining the exact location of troop units, aircraft and vehicles, providing information for making command and control decisions for other systems attached to the PLRS network. The controlling element of the system is the sheltered master unit which houses the computer and communications control electronics. The master unit also provides the position, identity and formatted message traffic to the tactical combat operations centers which use this information to direct battlefield maneuvers.

The PLRS continuously monitors and displays unit locations and movements as they occur. Position accuracies are sufficient to allow close fire support and to provide the PLRS user with accurate range and bearing information for navigation on the ground or in the air. Aircraft position accuracies are within a few feet, with the position updates surpassing present-day radar capabilities. The PLRS configuration is shown in Figure L-2.

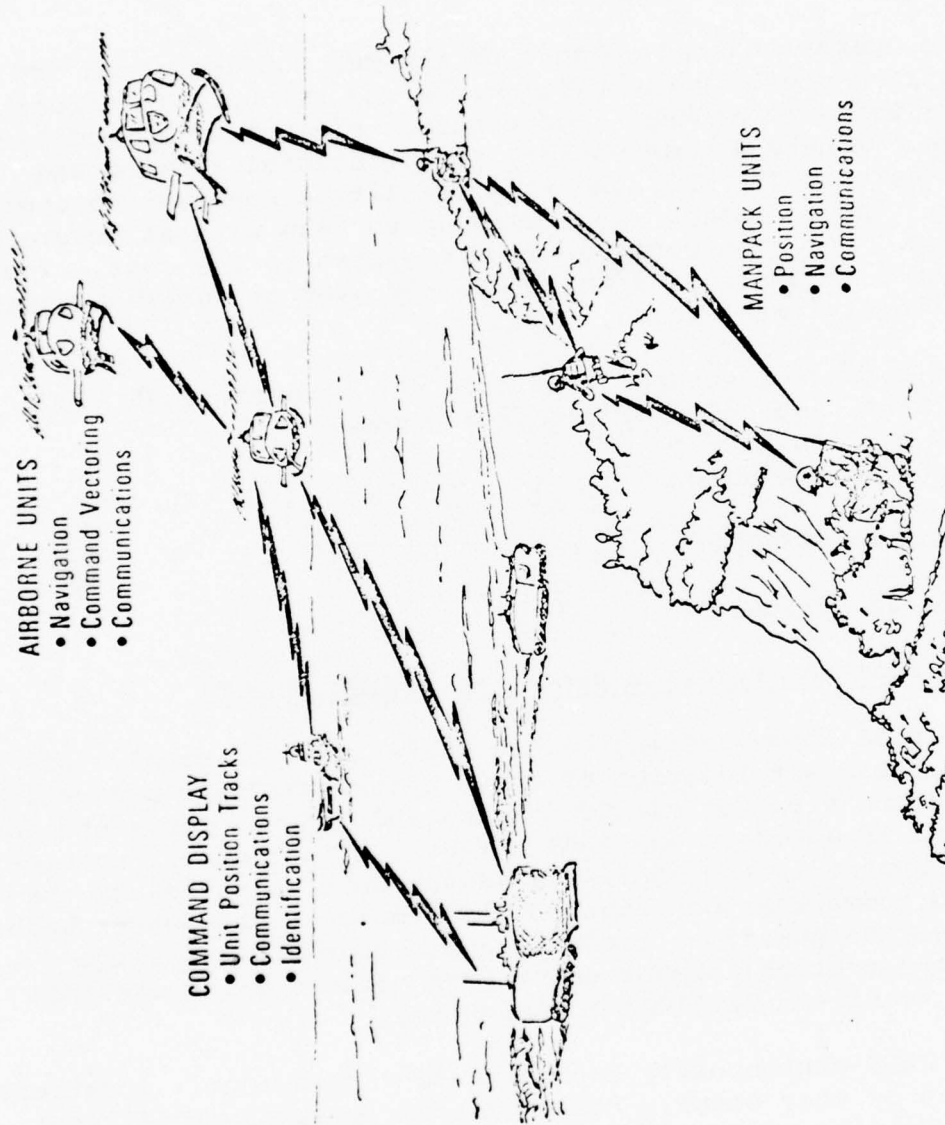

P3240

Figure L-2. Position Location Reporting System Configuration

Currently, two PLRS EDM Systems have been designed -- one by Hughes Aircraft Company and the other by General Dynamics Corporation. The Hughes system is a time-ordered PLRS that provides synchronized communications between individual users and the master unit. The General Dynamics system is an interrogate/respond PLRS that allows addressing of individual units by the master unit. Both systems contain over 1,000 reporting slots for assignment to individual PLRS users.

To compute ranges by time of arrival of signals, critical line-of-sight properties are required by the system. To achieve the required area coverage for system performance, each user unit automatically performs transmission relays to keep even the most non-line-of-sight user in the network.

3. Position Reporting and Recording System (PRRS)

The PRRS provides accurate location information by using mobile transmitters. These mobile units can be carried by troops, vehicles or aircraft.

A series of fixed antennas detect the signals from each mobile unit and relay the signal to the computer terminal for determining the exact location of the mobile units. The computer system also records the location data on magnetic tape with timing data. The location and identification data for each mobile unit are displayed on a screen with a synchronized gridline for use by test control officers and analysis personnel.

The PRRS consists of the following equipment:

- Mobile Units (MU) -- Transmits three unique frequencies in the 1,600 to 1,800KHZ range. Adaptable to manpack, ground vehicle or aircraft operation, with minor modifications. Powered by 28V dc battery with continuous operation up to 10 hours.
- Basic Array (BA) -- These units are electronic packages mounted on 150 foot steel towers. They are unmanned self-contained systems monitored by the central processing facility (CPF). Receives 600 frequencies from the mobile units and converts these frequencies into UHF, then transmits to the central display unit. Operates on commercial power, but has standby battery power.
- Central Processing Facility (CPF) -- This facility includes a UHF transceiver, tone tracking receivers (TTR), general purpose computer, a display generator and several computer peripherals.

The equipment operates on commercial power with standby generators and batteries. Man-machine interface to the CPF is through either the ASR-33 teletype or the video display terminal.

- Central Display Unit (CDU) -- Consists of a 17-in. CRT, a projector and a 8X6 foot screen, a light pen and keyboard controls. Primary purpose for this equipment is for test support.
- Field Display Units (FDU)-- Same as the Central Display Unit.

The preceding descriptions of the various "position finding" equipments were brought forward for information purposes regarding existing systems and their highlights.

B. CONCLUSIONS

In conclusion, the position finding systems discussed above demonstrate sufficient operational potential for the intended application, but are considered too costly and bulky for the optimum system.

APPENDIX M

HIGH RISK AREAS

HIGH RISK AREAS

A. NON-SELECTED SYSTEMS

1. RF Trilateration System High-Risk Areas

a. General

The RF Trilateration Scheme, while considered marginally technically feasible, is expensive to acquire, but relatively inexpensive to operate. The other principle objection is that it must be completely overlaid on the MILES direct-fire simulation system. It does score very high in value as a training system (see appendix B).

b. Precision of Propagation - Time Measurement

The use of only moderately high RF frequencies, to allow the use of the ducting of RF signals along the interface surface between atmosphere and the Earth, has been indicated as necessary for system operation in hilly terrain. This requirement is essential to ensure reception of signals. Such propagation geometry introduces the necessity of accepting stretched propagation paths (time-difference stretching) together with distortion of pulse shapes. Both of these propagation-path phenomena introduce inaccuracy of intended location of places where the weapon-effects signals can be decoded. The areas in which decoding would result are both displaced and considerably enlarged as a result. This result may be considered a serious technical barrier, except in theaters where transmission antennas can be high enough to reach all useful points with line-of-sight propagation. Aside from the MILES interface problem and high acquisition/maintenance costs, this technical problem is the principle reason for the rejection of the RF multilateration scheme until such time as adequate experiments can indicate the operational feasibility of this approach.

c. Frequency Allocation and Bandwidth

To make accurate time-of-propagation measurements, it is essential that wide-bandwidth signals be transmitted and accurately processed in receivers. At the relatively low RF center frequencies needed, it would be rather difficult, if not impractical, to obtain an adequate frequency/power/bandwidth allocation in the United States and Europe. Unless assignments could be made within military

bands, with the displacement of other military functions on a temporary regional basis, this would be a very serious problem to overcome.

2. System "X"

In the System "X" concept, the sonic overpressure from an accurately placed visual cue round is used as a measure of distance of a person or target from the simulated burst. A near-simultaneous low power RF signal is used to identify the round or event. Both signals are required to carry out weapon effects simulation. On-target computation of vulnerability then determines kill-effects. The technical problem here is to assure an accurate overpressure measurement, without having the sensor also sensitive to other types of sounds, or even more importantly to inevitable mechanical shocks. Because it is impractical to control the range of the auxiliary RF signal, the result would inevitably be kill-effect generation at places widely separated from the intended points. Intensive effort to solve the identical sensor problem on another program met with no success. This system is consequently considered as technically infeasible at this time and it is therefore rejected until such time as a sensor for single-overpressure pulses can be produced that will discriminate against other sounds and mechanical shocks.

B. SELECTED SYSTEM APPROACHES

1. General

The selected scanning laser system approach and all variants deemed practical make use of laser signals encoded so as to signify indirect-fire weapon effects. There are no real technical barriers involved in any of these approaches. The risk areas are associated with terrain and weather intervisibility variables. These risk areas are discussed below. It is emphasized that only practical experience in real terrain can give an adequate evaluation of the overall suitability of the laser approach to indirect-fire simulation.

a. Basic Terrain Problems

The terrain's basic contour, together with the use of a scanning laser transmitter, presents an obvious problem in well-simulating the lethal area of a simulated direct-fire event. The scanning laser transmitter concept allows the operator to adjust the simulated effects area reasonably well in a gross sense, but detail defilade or contour can make some "targets" within the area

"unavailable". To minimize this risk, a fairly large scope of standoff range is allowed (to 1 km). This standoff range allows the operators to seek an elevated or otherwise favorable position relative to deployed force elements.

b. Nap-of-the Earth Problems

Detail features of the terrain such as vegetation, buildings and other culture which extend above the basic terrain also interfere to some extent with intervisibility between scanning lasers and targeted force-elements. Again, taking elevated or favorable positions will increase the operator/laser-target intervisibility factor, but in some situations, notably when force elements are in forested areas, the long-range standoff of the scanning laser cannot be effective. In these cases, it is necessary to use the deliberate signaling of individual targets by aimed (MILES-type) laser transmitters encoded with proper weapon codes. It is envisioned that this would be done by the visual cuers in response to direction by the system net control station (SNCS) on the basis of decisions made there. Generally, the location of such effects by fielded personnel can be quite good, so that if the targeted elements are not actually located near the target points as designated, no effects would be achieved. This is, however, a very synthetic procedure and might have a relatively low value in terms of training effectiveness.

c. Weather Problems (Visibility)

Using the selected laser indirect-fire simulation schemes, weather effects on position-finding ability, target-finding ability and laser effective range must be considered.

With the sextant-calculator scheme of self-location, generally using objects of from 1 to 2.5 km distance, the system will obviously lose effectiveness when visibility is less than this distance. However, the auxiliary method of position-finding, by means of reference to recorded visible objects, permits good self-location accuracy even in severely degraded visibility.

The laser is aimed at the target point either by map inspection or magnetic azimuth/range estimation. Both techniques require target area visibility. The laser maximum range of 1km indicates that visibility impacts target-finding only when less than 1 km. However, the 1 km maximum laser range is achievable only in visibilities better than 10 km (see Figure C-27 in Appendix C) and achievable range remains less than visibility for visibilities

down to 400 m. Therefore, visibility most seriously affects operation through its impact on achievable laser range (that is, delivering required signal power density at the target point). For example, 1 to 2.5 km visibility is adequate for position-finding and target-finding, but only permits a laser range of 600 to 800 m.

This visibility problem is probably more serious in Central Europe than in the United States. Only experiments in the field can give an adequate evaluation of the degradation of training effectiveness in poor weather.

d. Night-Time Problems

In the hours of darkness, certain difficulties arise in operation of the recommended laser indirect-fire simulation systems or variants:

- It is more difficult for field personnel to move about as needed;
- It is more difficult to aim and operate the devices with accuracy; and
- The recommended scheme of self-location requires light beacons.

The use of two additional components as auxiliary devices will greatly alleviate the mobility and aiming difficulties and also alleviate the self-location problem. There are:

- Night-vision goggles for all field personnel; and
- Use of low-level battlefield illumination simulating battlefield fires.

This component can be oil-burning flames at places where interference with operation will not occur while maintaining the illumination level low enough to prevent effective vision without night-vision aids.

The beacons used for position-finding can be filtered in the near infrared and use night vision photocathodes which are sensitive to the near infrared. This filter will make the beacons less obvious to trainee troops.

A further difficulty incurred during hours of darkness is operation of the hand-held calculators and record-keeping. A small, helmet-mounted lamp will aid in the performance of these functions, as it may be difficult to attain accurate near-focus with the night-vision goggles. The use of lamps in the field for this purpose may be objectionable. If the near-focus capability of the goggles is adequate, the lamps used can be filtered in the near infrared to avoid false cueing.

The risks involved in night operations are minor, but the use of night-vision devices is less effective than normal daylight vision. It must be expected that some night-vision difficulties will arise. Again, field evaluations are essential to evaluate the risks.

2. Visible Cues

There appear to be no truly technical risks involved in achieving a workable visual-cue system. The "risks" involved are in achieving an adequately effective cue round design from a psychological viewpoint within acceptable personnel safety limits. A relatively long-range round which reliably actuates at a safe height is desirable; however, longer range implies higher muzzle velocities and greater risk should a round malfunction or be fired into a too-low trajectory. A much more detailed study of this problem is needed, together with experiments on effectiveness of smoke clouds as visual cues. Safety studies and consultation with the Office of the Surgeon General are also needed. Further studies of alternate approaches to cueing trainees from the audio/visual viewpoint are needed. It is likely that the pyrotechnic cue would still be needed for fire adjustment purposes.

3. Shell Smoke Simulation

For purposes of training troops in the use of shell-smoke and its effectiveness in limiting the effectiveness of observation and use of their direct-fire weapons, ILS believes that truly effective smokes should be used when simulating the equivalents of shell-smoke fires. Any attempt to merely "cue" these effects is bound to be ineffective for training purposes. The recommendation, therefore, is that this be accomplished via surface-vehicle deployment of M-1, 10-lb hexachloracthane-zinc oxide-aluminum (HC) smoke pots in sufficient numbers to effect the shell-smoke simulation. There are no real technical risks in using this approach, but the advance cueing produced by the vehicular movement may be objectionable from a training viewpoint.

APPENDIX N

TARGET DECODER/ P_k ANALYZER

TARGET DECODER/ P_k ANALYZER

A. GENERAL DISCUSSION

The use of a non-impacted MILES system on troop-targets has the disadvantages that troop vulnerability cannot be varied by weapon type or by the troop's protective attitude. As a result, it is highly desirable to add an additional decoder/ P_k assessment subsystem to the MILES system. The subsystem required is estimated roughly as outlined herein with electronics elements and power drain as noted. In addition, as a minimum, the subsystem would require about three damped pendulous switches as conceived by Georgia Institute of Technology and described in Indirect-Fire Instrumentation Study final technical report EES/GIT Project A-1697-000, prepared under Contract N00014-75-C-0320. The transducer would, with interconnects, not exceed \$20.00 each.

B. TARGET DECODER/PROBABILITY OF KILL (P_k)

The MILES man-decoder presently uses the "large storage bank approach". This approach removes the capability of interpreting codes other than the man-kill code. The rationale here is for cost effectiveness, because there are greater quantities of man-worn detection systems. This is accomplished by including the man-kill code along with every unique weapons code transmission (ILS' concept eliminates the added man-kill code). Also, the MILES concept decodes only five bits of the code word and no probability of kill is associated with the man targets. It is desirable to increase the capability of the MILES system, (that is, provide decoding of 27 nine-bit weapons codes and include weighted probability of kill functions for both the man and vehicle targets). Also included would be the man-position detection system which detects the prone or standing position of the man.

Increasing the capability of the MILES approach would require the following additional hardware:

- 1 Shift Register MC14562
- 23 decoding gates
- Additional decode summary gates
- 2-4 Bit Magnitude Comparators
- 2-4 Bit Decode Counters
- 1 oscillator circuit (1 Ic, capacitor, 2 resistors)

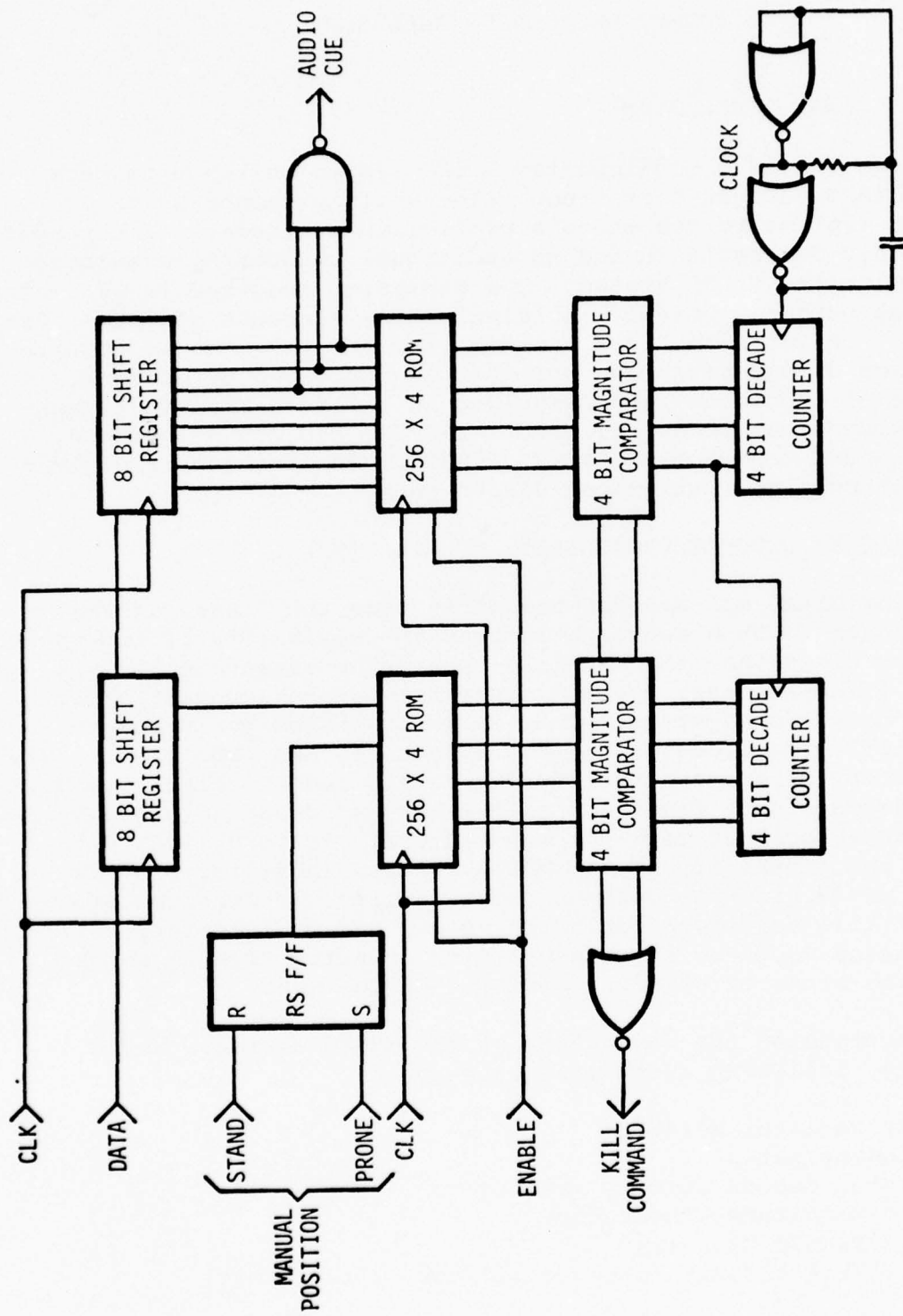

P3238

Figure N-1. Target Decoder and Pk Function Schematic

Using the same MILES decoding philosophy would be cumbersome because the additional bits to be decoded would demand a different type of logic element, thereby increasing the printed circuit board area requirements (estimates show thirty plus integrated circuits are required). For the decoding logic, it would be better to go medium scale integration (MSI) and/or large scale integration (LSI) low-power complementary metal-oxide semiconductor (CMOS) technology. This type logic would reduce area requirements and by using the low power CMOS technology, power can be held to a minimum level (\approx 10 mW).

Basically, the MILES decoding philosophy will be used, but the decoding technique will be changed and the probability of kill function will be added.

The weapons code data is shifted into the shift registers serially and becomes parallel data at the outputs of these shift registers (16-bit capability, but using only nine bits). The nine bits are decoded in the two read-only memories (ROM) to give unique probability figures for 27 possible weapon's codes. These probability codes are compared with a free-running clock for comparison of equal to or less than coincidence which allows generation of a kill command.

For the man target, the vulnerability due to position of the man function is included to weigh the probability of kill of a man in either the standing or prone position. This function will be disabled for the other targets.

The audio cue code in this system is unique and can easily be decoded at the parallel outputs of the shift registers.

APPENDIX O

SYSTEMS COSTS

SYSTEMS COSTS

This appendix reflects a definitive cost breakout per system considered in the Indirect/Area Fire Simulation Study. It reflects the costs associated with labor, overhead, material G&A, direct government acquisition and development. Loading factors of 86% overhead and 18% G&A are applied as applicable. These costs are extended over the quantities required by two battalions in a typical training field of 30 x 15 km.

It should be noted that in purchasing large quantities of equipment (that is, radio communications) a significant cost reduction will be realized.

Acquisition GFE costs are those incurred by the government from a direct purchase of on the shelf stock from a firm other than ILS. Operational costs are those expendables (that is, visual cue devices, and lithium batteries) which are consumed in a typical 96 hour exercise.

Development costs are those incurred by the government in the development and test of a special use device.

Table O-1 reflects the cost of System 1. This system overlays MILES. It uses the MILES dual purpose laser transmitter, the M-79 grenade launcher, visual cue devices and a low fidelity no pager capability communications network. The total cost for a typical training field is \$180,600.

Table O-2 reflects the cost of System 2. This system overlays MILES. The basic difference between System 1 and System 2 is in the communications network. The communications network for System 2 is high fidelity and includes a paging capability. The cost for a typical training field is \$212,200.

System 3 is similar to System 2, the difference being in its position-finding capability. Two forms of position-finding are considered -- RMS Position Finding, Table O-4, at a cost per training field of \$55,386,200 and Sextant Position Finding, Table O-4, at a cost per training field of \$374,400.

Various options have been considered in System 4. Basically, System 4 overlays MILES, uses the ILS laser and sextant position-finding. The first option has no MILES impact; Table O-5, at a cost of \$687,700. The second option adds a target decoder and vulnerability assessment to System 4, Table O-6, at a cost of \$1,690,000. System 4A is either of these options and adds helicopter capability. The helicopter would not be permanently assigned to the exercise, but would be used only in special cases on a "borrow" basis at an approximate cost of \$200/hour.

The VHF Trilateration Ground Designation System overlays MILES. It designates audio/kill effect to a given set of map coordinates. It requires a sophisticated receiving device for RF signals. Table O-7 reflects a cost of \$9,048,700 per training field.

System "X" Sonic Overpressure uses sextant position finding, a sophisticated sensor and a high quantity of visual cue devices. Table O-8 reflects a cost of \$409,700 per training field.

Table O-1. System 1 Costs

(Dollars in fields are in thousands)

| Nomenclature | Unit Cost | One Field | | Two Fields | | Three Fields | | Five Fields | |
|--|-----------|-----------|-------|------------|-------|--------------|-------|-------------|-------|
| | | Qty | \$ | Qty | \$ | Qty | \$ | Qty | \$ |
| GFE: | | | | | | | | | |
| MILES Equipment | | | | | | | | | |
| MILES Laser (1) | | | | | | | | | |
| M-79 Grenade Launcher | | | | | | | | | |
| Acquisition GFE Costs: | | | | | | | | | |
| Repro VHF-FM Mobile/ Portable Transceiver | 900 | 34 | 30.6 | 68 | 61.2 | 102 | 91.8 | 170 | 153.0 |
| Operational Costs: | | | | | | | | | |
| Visual Cue Devices (2) | 6 | 750 | 4.5 | 1500 | 9.0 | 2250 | 13.5 | 3750 | 22.5 |
| Development Costs: | | | | | | | | | |
| 40-mm Audio/Visual cartridge (3) | | 1 | 150.0 | 1 | 150.0 | 1 | 150.0 | 1 | 150.0 |
| Total Dollars (4) | | | 180.6 | | 211.2 | | 241.8 | | 303.0 |

NOTES:

- (1) These would be an additional cost for a rifle-type stock for this laser device.
- (2) See note on page O-19.
- (3) See Appendix E.
- (4) Operational costs are not included in totals because they are expended with every 96 hr exercise.

Table O-2. System 2 Costs

(Dollars in fields are in thousands)

| Nomenclature | Unit \$ | One Field | | Two Fields | | Three Fields | | Five Fields | |
|---------------------------------|------------|-----------|------------|------------|------------|--------------|------------|-------------|------------|
| | | QTY | \$ | QTY | \$ | QTY | \$ | QTY | \$ |
| GFE: | | | | | | | | | |
| MILES Equipment | | | | | | | | | |
| MILES Laser (1) | | | | | | | | | |
| M-79 Grenade Launcher | | | | | | | | | |
| Acquisition GFE Cost: | | | | | | | | | |
| Communications Network: | | | | | | | | | |
| 1. Repco VHF-FM Two Way | 1,243 | 30 | 37.3 | 60 | 74.6 | 90 | 111.9 | 150 | 186.4 |
| a. Radio Pack Set | | 30 | 2.5 | 60 | 5.0 | 90 | 7.5 | 150 | 12.4 |
| b. Battery (Ni-Cad) | 83 | | | | | | | | |
| 2. Repco VHF-FM Mobile/Portable | | | | | | | | | |
| Radio Set: | 900 | 3 | 2.7 | 6 | 5.4 | 9 | 8.1 | 15 | 13.5 |
| a. Transceiver | | 12 | 2.9 | 24 | 5.9 | 36 | 8.8 | 60 | 14.7 |
| b. Encoder | 245 | | | | | | | | |
| SPARES: | | | | | | | | | |
| 1. Repco VHF-FM Two Way | 1,243 | 4 | 5.0 | 6 | 9.9 | 10 | 14.9 | 16 | 24.9 |
| a. Radio Pack Set | | 120 | 9.9 | 240 | 19.9 | 360 | 29.8 | 600 | 49.7 |
| b. Battery (Ni-Cad) | 83 | | | | | | | | |
| 2. Repco VHF-FM Mobile/Portable | | | | | | | | | |
| a. Transceiver | 900 | 1 | 0.9 | 2 | 1.8 | 3 | 2.7 | 5 | 4.5 |
| b. Encoder | 245 | 4 | <u>1.0</u> | 8 | <u>2.0</u> | 12 | <u>2.9</u> | 20 | <u>4.9</u> |
| Total Acquisition GFE Cost | | | 62.2 | | 124.5 | | 186.6 | | 311.0 |

Table O-2. System 2 Costs (cont'd)

(Dollars in fields are in thousands)

| Nomenclature | Unit \$ | One Field | | Two Fields | | Three Fields | | Five Fields | |
|----------------------------------|------------|-----------|--------------|------------|--------------|--------------|--------------|-------------|--------------|
| | | QTY | \$ | QTY | \$ | QTY | \$ | QTY | \$ |
| Operational Cost: | | | | | | | | | |
| Visual Cue Devices (2) | 6 | 7 | 4.5 | 1500 | 9.0 | 2250 | 13.5 | 3750 | 22.5 |
| Development Cost: | | | | | | | | | |
| 40-mm Audio/Visual Cartridge (3) | | 1 | <u>150.0</u> | 1 | <u>150.0</u> | 1 | <u>150.0</u> | 1 | <u>150.0</u> |
| Total Dollars (4) | | | 212.2 | | 274.5 | | 336.6 | | 461.0 |

NOTES:

- (1) These would be an additional cost for a rifle-type stock for this laser device.
- (2) See note on page O-19.
- (3) See Appendix E.
- (4) Operational Costs are not included in totals because they are expended with every 96 hr exercise.

Table O-3. System 3 - RMS Position Finding Costs

(Dollars in fields are in thousands)

| Nomenclature | Unit \$ | One Field | | Two Fields | | Three Fields | | Five Fields | |
|---|------------|-----------|--------------|------------|--------------|--------------|--------------|-------------|--------------|
| | | QTY | \$ | QTY | \$ | QTY | \$ | QTY | \$ |
| GFE: | | | | | | | | | |
| MILES Equipment | | | | | | | | | |
| MILES Laser (1) | | | | | | | | | |
| M-79 Grenade Launcher | | | | | | | | | |
| Acquisition GFE Cost: | | | | | | | | | |
| RMS Score : (2) | | | | | | | | | |
| A-Measure Range | 45,000 | 14 | 630.0 | 28 | 1,260.0 | 42 | 1,890.0 | 70 | 3,150.0 |
| B-Transponder | 22,000 | 2,472 | 54,384.0 | 4,944 | 108,768.0 | 7,416 | 163,152.0 | 12,360 | 271,920.0 |
| C-Master Control Station | 100,000 | 1 | 100.0 | 2 | 200.0 | 3 | 300.0 | 5 | 500.0 |
| D-Relay Station for LOS | 60,000 | 1 | 60.0 | 2 | 120.0 | 3 | 180.0 | 5 | 300.0 |
| Communications Network (Same as System 2) | | | <u>62.2</u> | | <u>124.4</u> | | <u>186.6</u> | | <u>311.0</u> |
| Total Acquisition GFE Cost | | | 55,236.2 | | 110,472.4 | | 165,708.6 | | 276,181.0 |
| Operational Cost: | | | | | | | | | |
| Visual Cue Devices (3) | 6 | 750 | 4.5 | 1,500 | 9.0 | 2,250 | 13.5 | 3,750 | 22.5 |
| Development Cost: | | | | | | | | | |
| 40-mm Audio/Visual Cartridge (4) | | | <u>150.0</u> | | <u>150.0</u> | | <u>150.0</u> | | <u>150.0</u> |
| Total Cost (5) | | | 55,386.2 | | 110,622.4 | | 165,858.6 | | 276,310.0 |

- NOTES:
- (1) These would be an additional cost for a rifle stock for this laser device.
 - (2) Spaces were not included in this estimate because RMS score is not unique to the Indirect-Area Fire Simulation System.
 - (3) See note on page O-19.
 - (4) See Appendix E.
 - (5) Operational Costs are not included in totals because they are expended with every 96 hr exercise.

Table O-4. System 3-Sextant Position Finding Costs

(Dollars in fields are in thousands)

| Nomenclature | Unit Cost | One Field | | Two Fields | | Three Fields | | Five Fields | |
|--|-----------|-----------|-------------|------------|-------------|--------------|-------------|-------------|--------------|
| | | QTY | \$ | QTY | \$ | QTY | \$ | QTY | \$ |
| GFE: | | | | | | | | | |
| MILES Equipment | | | | | | | | | |
| MILES Laser (1) | 1,300 | 30 | 39.0 | 60 | 78.0 | 90 | 117.0 | 150 | 195.0 |
| M-79 Grenade Launcher | 1,300 | 4 | 5.2 | 6 | 10.4 | 10 | 15.6 | 16 | 26.0 |
| | 31 | 60 | <u>1.9</u> | 120 | <u>3.7</u> | 180 | <u>5.6</u> | 300 | <u>9.3</u> |
| | | | 46.1 | | 92.1 | | 138.2 | | 230.3 |
| Labor: | | | | | | | | | |
| Sextant | | | 39.6 | | 79.2 | | 118.8 | | 198.1 |
| Spares: Sextant | | | | | | | | | |
| Night Beacon | | | | | | | | | |
| Total Labor Dollars | | | | | | | | | |
| Overhead 86% | | | | | | | | | |
| Material: | | | | | | | | | |
| Sextant | 336 | 30 | 10.1 | 60 | 20.2 | 90 | 30.2 | 150 | 50.4 |
| Spares-Sextant | 336 | 4 | 1.3 | 6 | 2.7 | 10 | 3.4 | 16 | 5.4 |
| Night Beacon | 438 | 60 | <u>26.3</u> | 120 | <u>52.6</u> | 180 | <u>78.8</u> | 300 | <u>131.4</u> |
| Total Material Dollars | | | 37.7 | | 75.5 | | 112.4 | | 187.2 |
| Total Labor, Overhead & Material | | | 123.4 | | 246.8 | | 369.4 | | 615.6 |
| G & A 18% | | | 22.2 | | 44.4 | | 66.5 | | 110.8 |
| Acquisition GFE Cost | | | | | | | | | |
| Communications Network (same as as System-2) | | | 62.2 | | 124.4 | | 186.6 | | 311.0 |
| Hand-Held Calculator | 295 | 30 | 8.9 | 60 | 17.7 | 90 | 26.6 | 150 | 44.3 |
| Batteries (Ni-Cad) | 10 | 30 | 0.3 | 60 | 0.6 | 90 | 0.9 | 150 | 1.5 |
| Spares: Calculator | 295 | 4 | 1.2 | 8 | 2.4 | 12 | 3.5 | 20 | 5.9 |
| Batteries (Ni-Cad) | 10 | 120 | <u>1.2</u> | 240 | <u>2.4</u> | 360 | <u>3.6</u> | 600 | <u>6.0</u> |
| Total Acquisition GFE Cost | | | 73.8 | | 147.5 | | 221.2 | | 368.7 |

Table O-4. System 3-Sextant Position Finding Costs (cont'd)

(Dollars in fields are in thousands)

| Nomenclature | Unit Cost | One Field | | Two Fields | | Three Fields | | Five Fields | |
|----------------------------------|-----------|-----------|-------|------------|-------|--------------|-------|-------------|---------|
| | | QTY | \$ | QTY | \$ | QTY | \$ | QTY | \$ |
| Operational Cost: | | | | | | | | | |
| Visual Cue Devices (2) | | 750 | 4.5 | 1500 | 9.0 | 2250 | 13.5 | 3750 | 22.5 |
| Development Cost: | | | | | | | | | |
| 40-mm Audio/Visual Cartridge (3) | | | 150.0 | | 150.0 | | 150.0 | | 150.0 |
| ILS System | | | 5.0 | | 5.0 | | 5.0 | | 5.0 |
| Total Development Cost | | | 155.0 | | 155.0 | | 155.0 | | 155.0 |
| Total Dollars (4) | | | 374.4 | | 593.7 | | 812.1 | | 1,250.1 |

NOTES:

- (1) These would be an additional cost for a rifle stock for this laser device.
- (2) See note on page O-19.
- (3) See Appendix E.
- (4) Operational Costs are not included in totals because they are expended with every 96 hr exercise.

Table O-5. System 4-ILS Laser-Sextant Position Finding Costs (1)

(Dollars in fields are in thousands)

| Nomenclature | Unit Cost | One Field | | Two Fields | | Three Fields | | Five Fields | |
|---|-----------|-----------|-------|------------|-------|--------------|-------|-------------|---------|
| | | QTY | \$ | QTY | \$ | QTY | \$ | QTY | \$ |
| GFE: | | | | | | | | | |
| MILES Equipment | | | | | | | | | |
| M-79 Grenade Launcher | | | | | | | | | |
| Labor: | | | | | | | | | |
| ILS Laser | 2,150 | 10 | 21.5 | 20 | 43.0 | 30 | 64.5 | 50 | 107.5 |
| Spares: Laser | 2,150 | 2 | 4.3 | 4 | 8.6 | 6 | 12.9 | 10 | 21.5 |
| Sextant | 1,300 | 30 | 39.0 | 60 | 78.0 | 90 | 117.0 | 150 | 195.0 |
| Spares: Sextant | 1,300 | 4 | 5.2 | 6 | 10.4 | 10 | 15.6 | 16 | 26.0 |
| Night Beacon | 31 | 60 | 1.9 | 120 | 3.7 | 180 | 5.6 | 300 | 9.3 |
| Total Labor Dollars | | | 71.9 | | 143.7 | | 215.6 | | 359.3 |
| Overhead 86 % | | | 61.8 | | 123.6 | | 185.4 | | 309.0 |
| Material: | | | | | | | | | |
| ILS Laser | 7,880 (2) | 10 | 78.8 | 20 | 155.8 | 30 | 222.0 | 50 | 367.5 |
| Spares: Laser | 7,880 (2) | 2 | 15.8 | 4 | 30.4 | 6 | 44.4 | 10 | 73.5 |
| Sextant | 336 | 70 | 10.1 | 60 | 20.2 | 90 | 30.2 | 150 | 50.4 |
| Spares: Sextant | 336 | 4 | 1.3 | 6 | 2.7 | 10 | 3.4 | 16 | 5.4 |
| Night Beacon | 438 | 60 | 26.3 | 120 | 52.6 | 180 | 78.8 | 300 | 131.4 |
| Total Material Dollars | | | 132.3 | | 261.7 | | 378.8 | | 628.2 |
| Total Labor, Overhead and Material G & A 18% | | | 266.0 | | 529.0 | | 779.8 | | 1,296.5 |
| Acquisition GFE Cost: | | | 47.9 | | 94.5 | | 140.4 | | 233.4 |
| Communications Network (same as System 2) | | | 62.2 | | 124.4 | | 186.6 | | 311.0 |
| Hand-Held Calculator | 295 | 30 | 8.9 | 60 | 17.7 | 90 | 26.6 | 150 | 44.3 |
| Batteries (Ni-Cad) | 10 | 30 | 0.3 | 60 | 0.6 | 90 | 0.9 | 150 | 1.5 |
| Spares: Calculator | 295 | 4 | 1.2 | 8 | 2.4 | 12 | 3.5 | 20 | 5.9 |
| Batteries (Ni-Cad) | 10 | 120 | 1.2 | 240 | 2.4 | 360 | 3.6 | 600 | 6.0 |
| Total Acquisition GFE Cost | | | 73.8 | | 147.5 | | 221.2 | | 368.7 |

Table O-5. System 4-IIS Laser-Sextant Position Finding Costs (1) (cont'd)

(Dollars in fields are in thousands)

| Nomenclature | Unit Cost | One Field | | Two Fields | | Three Fields | | Five Fields | |
|----------------------------------|-----------|-----------|-------|------------|---------|--------------|---------|-------------|---------|
| | | QTY | \$ | QTY | \$ | QTY | \$ | QTY | \$ |
| Operational Cost: | | | | | | | | | |
| Visual Cue Device (3) | 6 | 750 | 4.5 | 1500 | 9.0 | 2250 | 13.5 | 3750 | 22.5 |
| Laser Lithium Batteries | 9 | 30 | 0.3 | 60 | 0.5 | 90 | 0.8 | 150 | 1.4 |
| Laser Lithium Batteries | 7 | 90 | 0.6 | 180 | 1.3 | 270 | 1.9 | 450 | 3.2 |
| Total Operational Costs | | | 5.4 | | 10.8 | | 16.2 | | 27.1 |
| Development Cost: | | | | | | | | | |
| IIS Laser System | | 1 | 150.0 | | 150.0 | | 150.0 | | 150.0 |
| 40 mm Audio/Visual Cartridge (4) | | 1 | 150.0 | 1 | 150.0 | 1 | 150.0 | 1 | 150.0 |
| Total Dollars (5) | | | 300.0 | | 300.0 | | 300.0 | | 300.0 |
| Total Dollars (5) | | | 687.7 | | 1,071.0 | | 1,441.4 | | 2,198.6 |

NOTES:

- (1) System 4A is System 4, plus a helicopter on a "borrow" basis at approximately \$200/hr.
- (2) Material unit dollars used are \$7,880 on one field, \$7,590 on two fields, \$7,400 on three fields and \$7,350 on five fields.
- (3) See note on page O-19.
- (4) See Appendix E.
- (5) Operational Costs are not included in totals because they are expended with every 96 hr exercise.

Table O-6. System 4-ILS Laser-Sextant Position Finding
with added Target Decoder and Vulnerability Assessment Costs (1)

(Dollars in fields are in thousands)

| Nomenclature | Unit Cost | One Field | | Two Fields | | Three Fields | | Five Fields | |
|---------------------------------|-----------|-----------|-------|------------|-------|--------------|---------|-------------|---------|
| | | Qty | \$ | Qty | \$ | Qty | \$ | Qty | \$ |
| GPE: | | | | | | | | | |
| MILES Equipment | | | | | | | | | |
| M-79 Grenade Launcher | | | | | | | | | |
| Labor: | | | | | | | | | |
| ILS Laser | 2,150 | 10 | 21.5 | 20 | 43.0 | 30 | 64.5 | 50 | 107.5 |
| Spares: Laser | 2,150 | 2 | 4.3 | 4 | 8.6 | 6 | 12.9 | 10 | 21.5 |
| Sextant | 1,300 | 30 | 39.0 | 60 | 78.0 | 90 | 117.0 | 150 | 195.0 |
| Spares: Sextant | 1,300 | 4 | 5.2 | 6 | 10.4 | 10 | 15.6 | 16 | 26.0 |
| Night Beacon | 31 | 60 | 1.9 | 120 | 3.7 | 180 | 5.6 | 300 | 9.3 |
| Target Decoder | 110 | 2,472 | 271.9 | 4,944 | 543.8 | 7,416 | 815.8 | 12,360 | 1,359.6 |
| Vulnerability-Transducer System | 37 | 1,980 | 73.3 | 3,960 | 146.5 | 5,940 | 219.8 | 9,900 | 366.3 |
| Total Labor Dollars | | | 417.1 | | 834.2 | | 1,251.3 | | 2,085.5 |
| Overhead 86% | | | 358.7 | | 717.4 | | 1,076.1 | | 1,793.5 |
| Material: | | | | | | | | | |
| ILS Laser | 7,880(2) | 10 | 78.8 | 20 | 155.8 | 30 | 222.0 | 50 | 367.5 |
| Spares: Laser | 7,880(2) | 2 | 15.8 | 4 | 30.4 | 6 | 44.4 | 10 | 73.5 |
| Sextant | 336 | 30 | 10.1 | 60 | 20.2 | 90 | 30.2 | 150 | 50.4 |
| Spares: Sextant | 336 | 4 | 1.3 | 6 | 2.7 | 10 | 3.4 | 16 | 5.4 |
| Night Beacon | 438 | 60 | 26.3 | 120 | 52.6 | 180 | 78.8 | 300 | 131.4 |
| Target Decoder | 65 | 2,472 | 160.7 | 4,944 | 321.4 | 7,416 | 482.1 | 12,360 | 803.5 |
| Vulnerability-Transducer System | 15 | 1,980 | 29.7 | 3,960 | 59.4 | 5,940 | 178.2 | 9,900 | 148.5 |
| Total Material Dollars | | | 322.7 | | 774.3 | | 1,039.1 | | 1,580.2 |

Table O-6. System 4-ILS Laser-Sextant Position Finding
with added Target Decoder and Vulnerability Assessment Costs (1) (cont'd)

(Dollars in fields are in thousands)

| Nomenclature | Unit Cost | One Field | | Two Fields | | Three Fields | | Five Fields | |
|--|-----------|-----------|------------------|------------|------------------|--------------|------------------|-------------|------------------|
| | | Qty | \$ | Qty | \$ | Qty | \$ | Qty | \$ |
| Total Labor, Overhead and Material G&A 18% | | | 1,098.5 197.7 | | 2,325.9 418.7 | | 3,366.5 606.0 | | 5,459.2 982.7 |
| Acquisition GFE Cost | | | | | | | | | |
| Communications Network (same as system 2) | | | 62.2 | | 124.4 | | 186.6 | | 311.0 |
| Hand Held Calculator | 295 | 30 | 8.9 | 60 | 17.7 | 90 | 26.6 | 150 | 44.3 |
| Batteries (Ni-Cad) | 10 | 30 | 0.3 | 60 | 0.6 | 90 | 0.9 | 150 | 1.5 |
| Spares: Calculator Batteries (Ni-Cad) | 295 | 4 | 1.2 | 8 | 2.4 | 12 | 3.5 | 20 | 5.9 |
| Batteries (Ni-Cad) | 10 | 120 | 1.2 | 240 | 2.4 | 360 | 3.6 | 600 | 6.0 |
| Total Acquisition GFE Cost | | | 73.8 | | 147.5 | | 221.2 | | 368.7 |
| Operational Cost: | | | | | | | | | |
| Visual Cue Device (3) | 6 | 750 | 4.5 | 1,500 | 9.0 | 2,250 | 13.5 | 3,750 | 22.5 |
| Laser Lithium Batteries | 9 | 30 | 0.3 | 60 | 0.5 | 90 | 0.8 | 150 | 1.4 |
| Laser Lithium Batteries | 7 | 90 | 0.6 | 180 | 1.3 | 270 | 1.9 | 450 | 3.2 |
| Total Operational Costs | | | 5.4 | | 10.8 | | 16.2 | | 27.1 |
| Development Cost: | | | | | | | | | |
| ILS Laser System | | 1 | 170.0 | 1 | 170.0 | 1 | 170.0 | 1 | 170.0 |
| 40 mm audio/visual cart-ridge (4) | | 1 | 150.0 | 1 | 150.0 | 1 | 150.0 | 1 | 150.0 |
| Total Development Costs | | | 320.0 | | 320.0 | | 320.0 | | 320.0 |
| Total Dollars: (5) | | | 1,690.0 | | 3,212.1 | | 4,513.7 | | 7,130.6 |

Notes:

- (1) System 4A is System 4, plus a helicopter on a "borrow" basis at approximately \$200/hr.
- (2) Material unit dollars used are \$7,880 on one field, \$7,590 on two fields, \$7,400 on three fields and \$7,350 on five fields.
- (3) See note on page O-19.
- (4) See Appendix E.
- (5) Operational costs are not included in totals because they are expended with every 96 hr exercise.

Table O-7. VHF Trilateration Ground Designation System Costs

(Dollars in fields are in thousands)

| Nomenclature | Unit Cost | One Field | | Two Fields | | Three Fields | | Five Fields | |
|--------------------------|-----------|-----------|---------|------------|---------|--------------|---------|-------------|---------|
| | | Qty | \$ | Qty | \$ | Qty | \$ | Qty | \$ |
| GFE: | | | | | | | | | |
| MILES Equipment | | | | | | | | | |
| M-79 Grenade Launcher | | | | | | | | | |
| Labor: | | | | | | | | | |
| Trilateration Equipment: | | | | | | | | | |
| Master Station | 820 | 1 | 0.8 | 2 | 1.6 | 3 | 2.5 | 5 | 4.1 |
| Slave Station | 730 | 2 | 1.5 | 4 | 2.9 | 6 | 4.4 | 10 | 7.3 |
| Designation Receiver | 820(1) | 2,472 | 2,027.0 | 4,944 | 3,658.6 | 7,416 | 4,894.6 | 12,360 | 7,107.0 |
| Spares: | | | | | | | | | |
| Master Station Processor | 820 | 1 | 0.8 | 2 | 1.6 | 3 | 2.5 | 5 | 4.1 |
| Slave Station Decoder | 730 | 2 | 1.5 | 4 | 2.9 | 6 | 4.4 | 10 | 7.3 |
| Designation Receiver | 820(1) | 325 | 266.5 | 650 | 481.0 | 975 | 643.5 | 1,625 | 934.4 |
| Sextant | 1,300 | 16 | 20.8 | 32 | 41.6 | 64 | 83.2 | 80 | 104.0 |
| Spares: Sextant | 1,300 | 2 | 2.6 | 4 | 5.2 | 6 | 7.8 | 10 | 13.0 |
| Night Beacon | 31 | 60 | 1.9 | 120 | 3.7 | 180 | 5.6 | 300 | 9.3 |
| Total Labor Dollars | | | 2,323.4 | | 4,199.1 | | 5,648.5 | | 8,190.5 |
| Overhead 86% | | | 1,998.1 | | 3,611.3 | | 4,857.6 | | 7,043.8 |
| Material: | | | | | | | | | |
| Trilateration Equipment: | | | | | | | | | |
| Master Station | 1,200 | 1 | 1.2 | 2 | 2.4 | 3 | 3.6 | 5 | 6.0 |
| Slave Station | 990 | 2 | 2.0 | 4 | 7.9 | 6 | 11.9 | 10 | 19.8 |
| Designation Receiver | 820(1) | 2,472 | 2,027.0 | 4,944 | 3,658.6 | 7,416 | 4,894.6 | 12,360 | 7,107.0 |

Table O-7. VHF Trilateration Ground Designation System Costs (cont'd)

(Dollars in fields are in thousands)

| Nomenclature | Unit Cost | One Field | | Two Fields | | Three Fields | | Five Fields | |
|--|-----------|-----------|----------------|------------|----------------|--------------|----------------|-------------|----------------|
| | | Qty | \$ | Qty | \$ | Qty | \$ | Qty | \$ |
| Material (cont'd) | | | | | | | | | |
| Spares: | | | | | | | | | |
| Master Station Transmitter | 510 | 1 | 0.5 | 2 | 1.0 | 3 | 1.5 | 5 | 2.6 |
| Master Station Processor | 690 | 1 | 0.7 | 2 | 1.4 | 3 | 2.1 | 5 | 3.5 |
| Slave Station Receiver | 310 | 2 | 0.6 | 4 | 1.2 | 6 | 1.9 | 10 | 3.1 |
| Slave Station Transmitter | 510 | 2 | 1.0 | 4 | 2.0 | 6 | 3.1 | 10 | 5.1 |
| Slave Station Decoder | 170 | 2 | 0.3 | 4 | 0.7 | 6 | 1.0 | 10 | 1.7 |
| Designation Receiver | 820(1) | 325 | 266.5 | 650 | 481.0 | 975 | 643.5 | 1,625 | 934.4 |
| Sextant: | 336 | 16 | 5.4 | 32 | 10.8 | 48 | 16.1 | 80 | 26.9 |
| Spares: Sextant | 336 | 2 | 0.7 | 4 | 1.3 | 6 | 2.0 | 10 | 3.4 |
| Night Beacon | 438 | 30 | 13.1 | 60 | 26.3 | 90 | 39.4 | 150 | 65.7 |
| Total Material | | | <u>2,319.0</u> | | <u>4,194.6</u> | | <u>5,620.7</u> | | <u>8,179.2</u> |
| Total Labor, Overhead and Material | | | 6,640.5 | | 12,005.0 | | 16,126.8 | | 23,413.5 |
| Overhead 86% | | | 1,195.1 | | 2,160.9 | | 2,902.8 | | 4,214.0 |
| Acquisition Cost: | | | | | | | | | |
| Two-Way Radio VHF-FM | 1,243 | 16 | 19.9 | 32 | 39.8 | 48 | 59.7 | 80 | 99.4 |
| Battery (Ni-Cad) | 83 | 16 | 1.3 | 32 | 2.7 | 48 | 4.0 | 80 | 6.6 |
| Spares: Two-Way Radio | 1,243 | 2 | 2.5 | 4 | 3.0 | 6 | 7.5 | 10 | 12.4 |
| Batteries (Ni-Cad) | 83 | 64 | 5.3 | 128 | 10.6 | 192 | 15.9 | 320 | 26.6 |
| Mobile/Portable Radio VHF-FM Transceiver | 900 | 2 | 1.8 | 4 | 3.6 | 6 | 5.4 | 10 | 9.0 |
| Encoder | 245 | 8 | 2.0 | 16 | 2.9 | 24 | 3.9 | 40 | 9.8 |
| Spares: Transceiver | 900 | 1 | 0.9 | 2 | 1.8 | 4 | 3.6 | 5 | 4.5 |
| Encoder | 245 | 4 | 1.0 | 8 | 2.0 | 12 | 2.9 | 20 | 4.9 |
| Hi-Reach Lift | 5,000 | 3 | 15.0 | 6 | 30.0 | 9 | 45.0 | 15 | 75.0 |
| Spares: Hi-Reach Lift | 5,000 | 1 | 5.0 | 2 | 10.0 | 3 | 15.0 | 5 | 25.0 |

Table O-7. VHF Trilateration Ground Designation System Costs (cont'd)

(Dollars in fields are in thousands)

| Nomenclature | Unit Cost | One Field | | Two Fields | | Three Fields | | Five Fields | |
|-------------------------------|-----------|-----------|---------|------------|----------|--------------|----------|-------------|----------|
| | | Qty | \$ | Qty | \$ | Qty | \$ | Qty | \$ |
| Acquisition GFE Cost (cont'd) | 6 | 3 | -- | 6 | -- | 9 | -- | 15 | 0.1 |
| Equipment Shelter (truck) | 6 | 1 | -- | 2 | -- | 3 | -- | 5 | -- |
| Spares: Shelter | GFE | 3 | -- | 5 | -- | 9 | -- | 15 | -- |
| Military 6 x 6 truck | 295 | 16 | 4.7 | 32 | 9.4 | 48 | 14.2 | 80 | 23.6 |
| Calculator | 10 | 16 | 0.2 | 32 | 0.3 | 48 | 0.5 | 80 | 0.8 |
| Batteries (Ni-Cad) | 295 | 2 | 0.6 | 4 | 1.2 | 6 | 1.8 | 10 | 3.0 |
| Spares: Calculator | 10 | 192 | 1.9 | 384 | 3.8 | 576 | 5.8 | 960 | 9.6 |
| Batteries(Ni-Cad) | | | 63.1 | | 121.1 | | 187.2 | | 310.3 |
| Total Acquisition GFE Cost | | | | | | | | | |
| Operational Cost: | | | | | | | | | |
| Visual Cue Devices (2) | 6 | 750 | 4.5 | 1,500 | 9.0 | 2,250 | 13.5 | 3,750 | 22.5 |
| Designator Lithium Batteries | 6 | 50 | 0.3 | 100 | 0.6 | 150 | 0.9 | 250 | 1.5 |
| Total Operational Cost | | | 4.8 | | 9.6 | | 14.4 | | 24.0 |
| Development Cost: | | | | | | | | | |
| 40 mm audio/visual car- | | | | | | | | | |
| tridges (3) | | | 150.0 | 1 | 150.0 | 1 | 150.0 | 1 | 150.0 |
| Trilateration | | 1 | 1,000.0 | 1 | 1,000.0 | 1 | 1,000.0 | 1 | 1,000.0 |
| Total Development Cost | | | 1,150.0 | | 1,150.0 | | 1,150.0 | | 1,150.0 |
| Total Dollars (4) | | | 9,048.7 | | 15,437.0 | | 20,366.8 | | 29,087.8 |

Notes:

- (1) Unit costs are \$820 for one field, \$740 for two fields, \$660 for three fields and \$575 for five fields.
- (2) See note on page O-19.
- (3) See Appendix E.
- (4) Operating costs are not included in totals because they are expended with every 96 hr exercise.

Table O-8. System "X" Sonic Overpressure Costs

(Dollars in fields are in thousands)

| Nomenclature | Unit Cost | One Field | | Two Fields | | Three Fields | | Five Fields | |
|----------------------------------|-----------|-----------|------|------------|-------|--------------|-------|-------------|-------|
| | | Qty | \$ | Qty | \$ | Qty | \$ | Qty | \$ |
| GFE: | | | | | | | | | |
| MILES Equipment | | | | | | | | | |
| M-79 Grenade Launcher | | | | | | | | | |
| Labor: | | | | | | | | | |
| Communications Network: | | | | | | | | | |
| Receiver | 820 | 16 | 13.1 | 32 | 26.2 | 48 | 39.4 | 80 | 65.6 |
| Transmitter/Receiver/Sensor | 820 | 16 | 13.1 | 32 | 26.2 | 48 | 39.4 | 80 | 65.6 |
| Spares: Receiver | 820 | 2 | 1.6 | 4 | 3.3 | 6 | 4.9 | 10 | 8.2 |
| Transmitter/Receiver/Sensor | 820 | 2 | 1.6 | 4 | 3.3 | 6 | 4.9 | 10 | 8.2 |
| Sextant | 1,300 | 16 | 20.8 | 32 | 41.6 | 48 | 62.4 | 80 | 104.0 |
| Spares: Sextant | 1,300 | 16 | 20.8 | 32 | 41.6 | 48 | 62.4 | 80 | 104.0 |
| Night Beacon | 31 | 60 | 1.9 | 120 | 3.7 | 180 | 5.6 | 300 | 9.3 |
| Total Labor Dollars | | | 72.9 | | 145.9 | | 219.0 | | 364.9 |
| Overhead 86% | | | 62.8 | | 125.5 | | 188.3 | | 313.8 |
| Material: | | | | | | | | | |
| Communication Network | | | | | | | | | |
| Receiver | 745 | 16 | 11.9 | 32 | 23.8 | 48 | 35.8 | 80 | 59.6 |
| Transmitter/Receiver/Sensor | 690 | 16 | 11.0 | 32 | 22.1 | 48 | 33.1 | 80 | 55.2 |
| Spares: Receiver | 745 | 2 | 1.5 | 4 | 3.0 | 6 | 4.5 | 10 | 7.5 |
| Transmitter/Receiver/Sensor | 690 | 2 | 1.4 | 4 | 2.8 | 6 | 4.1 | 10 | 6.9 |
| Receiver - Batteries (Ni-Cad) | 26 | 64 | 1.7 | 128 | 3.3 | 192 | 5.0 | 320 | 8.3 |
| Transmitter - Batteries (Ni-Cad) | 26 | 64 | 1.7 | 128 | 3.3 | 192 | 5.0 | 320 | 8.3 |

Table O-8. System "X" Sonic Overpressure Costs (cont'd)
(Dollars in fields are in thousands)

| Nomenclature | Unit Cost | One Field | | Two Fields | | Three Fields | | Five Fields | |
|------------------------------------|-----------|-----------|-------|------------|-------|--------------|-------|-------------|---------|
| | | Qty | \$ | Qty | \$ | Qty | \$ | Qty | \$ |
| Material (cont'd) | | | | | | | | | |
| Sextant | 336 | 2 | 0.7 | 4 | 1.3 | 6 | 2.0 | 10 | 3.4 |
| Spares: Sextant | 336 | 2 | 0.7 | 4 | 1.3 | 6 | 2.0 | 10 | 3.4 |
| Night Beacon | 438 | 60 | 26.3 | 120 | 52.6 | 180 | 78.8 | 300 | 131.4 |
| Total Material | | | 56.9 | | 113.5 | | 170.3 | | 284.0 |
| Total Labor, Overhead and Material | | | 192.6 | | 384.9 | | 577.6 | | 962.7 |
| G&A 18% | | | 34.7 | | 69.3 | | 140.0 | | 173.3 |
| Acquisition GFE Cost: | | | | | | | | | |
| Calculator | 295 | 16 | 4.7 | 32 | 9.4 | 48 | 14.2 | 80 | 23.6 |
| Battery (Ni-Cad) | 10 | 16 | 0.2 | 32 | 0.3 | 48 | 0.5 | 80 | 0.8 |
| Spares: Calculator | 295 | 2 | 0.6 | 4 | 2.4 | 6 | 1.8 | 10 | 3.0 |
| Batteries (Ni-Cad) | 10 | 192 | 1.9 | 384 | 3.8 | 576 | 5.8 | 960 | 9.6 |
| Total Acquisition GFE Cost | | | 7.4 | | 15.9 | | 22.3 | | 37.0 |
| Operational Cost: | | | | | | | | | |
| Visual Cue Devices (1) | 6 | 3,062 | 18.4 | 6,124 | 36.7 | 9,186 | 55.1 | 15,310 | 91.9 |
| Development Cost: | | | | | | | | | |
| 40 mm audio/visual cartridges (2) | | 1 | 150.0 | 1 | 150.0 | 1 | 150.0 | 1 | 150.0 |
| ILS System (3) | | | 25.0 | | 25.0 | | 25.0 | | 25.0 |
| Total Dollars (4) | | | 175.0 | | 175.0 | | 175.0 | | 175.0 |
| | | | 409.1 | | 645.1 | | 878.9 | | 1,348.0 |

Notes:

- (1) See note on page O-19.
- (2) See Appendix E.
- (3) Considered to be very conservative because much research would have to be accomplished before development could commence.
- (4) Operational costs are not included in totals because they are expended with every 96 hr exercise.

Note: The AAI, Inc. estimate used here is the cost per-round of the visible cues. However, on the basis that costs should bear some reasonable relationship to costs of materials, tools (tool life) and labor, ILS is of the opinion that the AAI estimate is high by a factor of at least two. This opinion is made on the basis that the per-round cost as quoted is roughly equivalent to the retail cost of a box of 25 high-brass shotgun shells and that a large part of this latter cost is due to the use of about 33 oz of expensive lead shot. It is true that shotgun shells are made in the millions per year of a type, but they are produced on automatic machinery under stringent quality control. The cue rounds should also be produced in the same manner.