

ADA 034515

6

FG

ANNUAL REPORT

ARPA Order Number: 2840, Amend. #4

Program Code Number: 421

Contractor: The Trustees of Columbia University  
in the City of New York  
116th and Broadway  
New York, NY 10027

Effective Date of Contract: 75 DEC 03

Contract Expiration Date: 76 DEC 02

Amount of Contract: \$35 000

Contract Number: N00014-76-C-0466

Principal Investigator: Richard N. Zare  
(212)-280-2017

Scientific Officer: Physics Program  
Physical Sciences Division  
Office of Naval Research  
800 North Quincy Street  
Arlington, VA 22217

Short Title of Work: "Absolute Photon Yields"

Sponsored by: Advanced Research Projects Agency  
ARPA Order No. 2840/4

Disclaimer: The views and conclusions contained  
in this document are those of the  
authors and should not be inter-  
preted as necessarily representing  
the official policies, either  
expressed or implied, of the  
Advanced Research Projects Agency  
or the U.S. Government.

DDC  
RECEIVED  
JAN 17 1977  
RECEIVED

A

DISTRIBUTION STATEMENT A  
Approved for public release  
Distribution Unlimited

UNCLASSIFIED

SECURITY CLASSIFICATION OF THIS PAGE (When Data Entered)

REPORT DOCUMENTATION PAGE		READ INSTRUCTIONS BEFORE COMPLETING FORM
1. REPORT NUMBER	2. GOVT ACCESSION NO.	3. RECIPIENT'S CATALOG NUMBER
4. TITLE (and Subtitle) <u>DETERMINATION OF ABSOLUTE PHOTON YIELDS</u> <u>IN CHEMILUMINESCENT REACTIONS.</u>		5. TYPE OF REPORT & PERIOD COVERED Annual Technical Rept. Dec 75-2 Dec 76
7. AUTHOR(s) Prof. Richard N. ZARE		6. PERFORMING ORG. REPORT NUMBER
9. PERFORMING ORGANIZATION NAME AND ADDRESS Prof. Richard N. Zare ✓ Chemistry Department, Columbia University New York, NY 10027		8. CONTRACT OR GRANT NUMBER(s) N00014-76-C-0466, NEW WARPA Order - 2840
11. CONTROLLING OFFICE NAME AND ADDRESS Advanced Research Projects Agency 1400 Wilson Boulevard Arlington, VA 22209		10. PROGRAM ELEMENT, PROJECT, TASK AREA & WORK UNIT NUMBERS ARPA Order No. 2840/4 Program Code 421
14. MONITORING AGENCY NAME & ADDRESS (if different from Controlling Office) Physics Program Office of Naval Research 800 North Quincy St. Arlington, VA 22217		12. REPORT DATE Dec 1976
16. DISTRIBUTION STATEMENT (of this Report) Approved for public release; distribution unlimited.		13. NUMBER OF PAGES 41
17. DISTRIBUTION STATEMENT (of the abstract entered in Block 20, if different from Report)		15. SECURITY CLASS. (of this report) Unclassified
18. SUPPLEMENTARY NOTES		15a. DECLASSIFICATION/DOWNGRADING SCHEDULE
19. KEY WORDS (Continue on reverse side if necessary and identify by block number) absolute photon yields; chemiluminescence; electronic-transition lasers		
20. ABSTRACT (Continue on reverse side if necessary and identify by block number) An experimental procedure is presented to measure the absolute photon yield, the percentage probability of emitting a visible photon per reactant molecule consumed, for chemiluminescent reactions under single collision conditions. Using a well-defined metal beam directed into a scattering gas at sub-millitorr pressures, this procedure is applied to the reactions $Sm+N_2O$ , $Sm+F_2$ , $Ba+N_2O$ , and $Ba+NO_2$ to obtain the photon yields in the 350-800 nm range of 0.18%, 5.5%, 1.1% and 0.08% respectively, where the estimated uncertainty is about 50%.		

ANNUAL REPORT

Contract: N0014-76-C-0466

December 3, 1975 - December 2, 1976

Description/Specifications:

"The Contractor shall establish a standard procedure for the measurement of absolute photon yields for chemiluminescent reactions over the pressure range from 0.1 mtorr to a few torr of inert gas. Toward this end the Contractor shall measure the photon flux, the metal flux, the oxidant flux, the chemiluminescence cross section and the total cross section for the reaction of Sm with nitrous oxide."

So began this study... ... The following is a technical report of our accomplishments during the last year.

DETERMINATION OF ABSOLUTE PHOTON YIELDS UNDER SINGLE-COLLISION  
CONDITIONS

C. R. Dickson,<sup>\*</sup> S. M. George,<sup>†</sup> and R. N. Zare

Department of Chemistry

Columbia University

New York, New York 10027

<sup>\*</sup>Present address: Materials Research Center, Allied Chemical,  
P.O. Box 1021R, Morristown, NJ 07960.

<sup>†</sup>Present address: Department of Chemistry, Yale University,  
New Haven, CT 06520.

## ABSTRACT

An experimental procedure is presented to measure the absolute photon yield, the percentage probability of emitting a visible photon per reactant molecule consumed, for chemiluminescent reactions under single-collision conditions. Using a well-defined metal beam directed into a scattering gas at sub-millitorr pressures, this procedure is applied to the reaction  $\text{Sm} + \text{N}_2\text{O}$ ,  $\text{Am} + \text{F}_2$ ,  $\text{Ba} + \text{N}_2\text{O}$ , and  $\text{Ba} + \text{NO}_2$  to obtain the photon yields in the 350-800 nm range of 0.18%, 5.5%, 1.1% and 0.08% respectively, where the estimated uncertainty is about 50%. The absolute photon yields for each of these reactions initially increases with scattering gas pressure, demonstrating that secondary collisions "feed" radiating states from dark, reservoir states. It is suggested that other relative photon yields can be put on an absolute basis by comparison with the  $\text{Sm} + \text{N}_2\text{O}$  chemiluminescent reaction.

ACCESSION NO.	
NTIS	White Section <input checked="" type="checkbox"/>
EDC	Diff. Section <input type="checkbox"/>
ORIGINATOR	<input type="checkbox"/>
JUSTIFICATION	
BY	
DISTRIBUTION/AVAILABILITY NOTES	
NO.	STAR. REF. SERIAL
A	

## I. INTRODUCTION

The possibility of a chemically-pumped electronic-transition laser system has recently stimulated the measurement of absolute photon yields for several chemiluminescent reactions.<sup>1-6</sup> Some of these reactions are reported to have high photon yields, such as  $\text{Sm} + \text{F}_2$  (~60%),<sup>3</sup>  $\text{Sm} + \text{N}_2\text{O}$  (~35%),<sup>3</sup> and  $\text{Ba} + \text{N}_2\text{O}$  (~20%).<sup>3,6</sup> All of these measurements were performed at pressures of several torr of argon and the fraction of electronic excitation appearing initially in the reaction products is obscured by the presence of many collisions. Thus, there is considerable interest in photon yield measurements in the sub-millitorr pressure range, because they provide information about the primary excitation process in a chemiluminescent reaction. We present here absolute photon yields for the reactions of  $\text{Sm} + \text{N}_2\text{O}$ ,  $\text{Sm} + \text{F}_2$ ,  $\text{Ba} + \text{N}_2\text{O}$ , and  $\text{Ba} + \text{NO}_2$  using a beam-gas arrangement at oxidant pressures of  $\sim 10^{-4}$  torr.

Since absolute photon yields have not been determined in the sub-millitorr pressure range previously, our procedure will be presented in some detail. In particular, the following quantities are measured: the photon flux, the metal flux, the oxidant flux, and the chemiluminescent cross section and the total cross section for the reaction. The photon yield is defined to be the percentage

number of photons emitted per oxidant molecule or metal atom consumed. For the beam-gas arrangement, this is found from the ratio of the chemiluminescent cross section to the total reaction cross section.

We propose that the reaction of Sm with  $N_2O$  can be used as a reference reaction for beam-gas chemiluminescence for several reasons. This reaction appears to be bright under beam conditions as well as in the presence of argon. The spectrum of SmO resulting from this reaction (See Fig. 1) has little structure at low resolution ( $\sim 5\text{\AA}$ ), and the chemiluminescence occurs over a wide range of wavelengths (450-750 nm). Samarium is relatively cheap, undergoes far less oxidation in air than barium, and produces beams of high flux at temperatures easily achieved in most laboratories (1000-1200 °K). A well characterized reaction such as  $Sm + N_2O$  now provides a basis for calibration in other laboratories as well as in our own.

## II. EXPERIMENTAL

### A. Beam apparatus

The beam apparatus, LABSTAR, which has been described previously,<sup>7</sup> is used to produce the chemiluminescent reactions. It consists of two differentially-pumped chambers, the lower of which is a water-cooled Astro-oven containing a cylindrical graphite heater and oven surrounded by three concentric tantalum heat shields (Fig. 2). The metal is heated until the vapor pressure reaches 0.01 to 0.1 torr. The effusive beam of metal enters the upper scattering chamber where it reacts with the oxidant molecules typically at pressures of  $10^{-5}$  to  $10^{-4}$  torr to produce chemiluminescence.

### B. Photon flux

The approach often taken is to calibrate an entire optical-detection system (spectrometer, lens, etc.) on an absolute basis to determine the photon flux for a chemiluminescent reaction. This requires that one correct for the change in geometry when the standard lamp is placed at the position of the reaction zone.

To avoid this difficulty, we have chosen to calibrate the optical-detection system that generates the spectra on a relative basis. We found that a relative calibration is reproducible to better than 1% under a variety of conditions (various spectrometer slit widths, with and without a lens in place, etc.). The results of the relative calibration of the optical-detection system used in our measurements are given in Table I. Figure 3 shows how the correction factors listed in Table I are generated. A scan of the standard lamp output is made with the spectrometer (Fig. 3a). Figure 3b is a plot of the correction factors by which the standard lamp output (Fig. 3a) is multiplied to obtain the actual photon flux output of the standard lamp (Fig. 3c).

The spectrometer and optics (including the standard lamp) is aligned by means of a helium-neon laser (see Fig. 4). The common belief that uncalibrated lamps have the same absolute spectral output within 15% of that for a calibrated lamp is not correct. To obtain results better than 10% with a standard lamp (Optronic Laboratories Model 245C), the current must be regulated to better than 0.1% and the actual current measurement must be made better than 1%. The current may be measured by monitoring the voltage drop across a precision resistor with a digital voltmeter. Alternatively, the power supply (Optronic Laboratories Model 65) may

be used. Since this supply maintains the required 6.50 amperes to better than 0.1%, we have chosen the use of the power supply to ensure the best calibration. It is important that the lamp orientation and the polarity of the electrical connections to the lamp are made in the manner specified by the manufacturer if reproducible results are desired.

To obtain an absolute calibration of the spectra corrected on a relative basis, the chemiluminescence is observed separately through three interference filters having a narrow bandwidth ( $<30 \text{ \AA}$ ). A photomultiplier tube behind a slit of known area views the interference filter (see Fig. 5). This optical-detection system is calibrated on an absolute basis with the standard tungsten-iodine lamp. The calibrated output is listed in Table II for each interference filter. Thus, the need to calibrate a spectrometer and lens arrangement on an absolute basis is entirely eliminated. While only one interference filter is necessary to provide an absolute calibration at all wavelengths, three such filters provide cross checks.

The Sm beam enters the scattering chamber through a 4.1 mm diameter hole, and the chemiluminescence appears as a very narrow, cylindrical beam of light. The geometry of the beam is not diffuse for the reaction of  $\text{Sm} + \text{N}_2\text{O}$  because the radiative lifetime of  $\text{SmO}$  is  $83 \pm 2 \text{ nsec.}$ <sup>9</sup> Let the chemiluminescent beam have a radiant flux

E in units of photons/sec. Then the photon flux F falling on a concentric cylinder a distance r away from the beam is given by<sup>10,11</sup>

$$F = \left( \frac{2\pi r}{C} \right) E \quad (1)$$

where C is the portion of the arc subtended by the slits in front of the photomultiplier. Notice that the illumination due to a cylinder of infinite extent varies inversely as the distance. This is analogous to the variation of the electric field with distance for a line charge of infinite length. Since the slit (0.3 cm x 1 cm) observes only a small portion of the length of the chemiluminescent beam (0.3 cm), the flux can be considered to be uniform in all radial directions. The metal beam is assumed to have a constant flux within the 0.3 cm observation zone and the light is assumed to be uniform within the small volume element observed.

To determine the number of photons emitted per second from this small volume, the chemiluminescent spectrum is corrected on a relative basis using the correction factors of Table I. The area under the chemiluminescent spectrum is proportional to the number of photons emitted per second. The absolute number of

photons emitted per second is obtained by observing the chemiluminescence through an interference filter whose output is calibrated on an absolute basis (Table II). The total number of photons emitted per second in all directions is then found from Eq. (1) by multiplying  $E$  by  $2\pi r/C$ . The spectral range covered is 350-800 nm.

### C. Metal flux

Because the "sticking coefficient" is not unity for most metals, quartz microbalance techniques and other thin film thickness monitors only measure the amount of metal actually deposited on the sensor and not necessarily the true metal beam flux. Consequently, we chose to collect the metal beam using a thin, hollow, glass sphere having an entrance port slightly larger than the beam diameter (see Fig. 6). Since little metal can escape, we expect the results to be reliable. The amount of metal deposited over a given time period is then determined by weighing the collection vessel before and after deposition. In the case of barium, the metal was allowed to convert completely to the oxide so that the best determination of the original amount of metal could be made. Five determinations were made of the Sm flux by collecting the metal over a three hour period. The average weight was

$0.0106 \pm 0.0021$  g. This corresponds to a Sm flux of  $4.53 \times 10^{15}$  atoms/cm<sup>2</sup>-sec. Similarly, the barium flux was found to be  $1.77 \times 10^{15}$  atoms/sec-cm<sup>2</sup>.

#### D. Oxidant flux

Pressure measurements are made with a corrosion-resistant capacitance manometer (Datametrix model 573A-10T-4A1-H5). Depending on the particular gas, the pressure read by an ionization gauge can be in error by a factor of two or three in the pressure range of  $10^{-4}$  torr. Because of the reactivity of the various oxidant gases used, we found it impossible to calibrate an ion gauge against the capacitance manometer. The input port of the capacitance manometer (3/8" stainless steel tube approximately 6" long) was less than 1/4" away from the reaction zone viewed by the photomultiplier when the photon flux was being measured. Efforts were made to eliminate any adsorbed water in this tube by heating it with a heat gun while the chamber was being evacuated. When the tube cooled sufficiently, it could be accurately zeroed and remained reasonably stable over a few minutes before the zero would have to be readjusted slightly.

The reliability of capacitance manometer measurements

has been checked by Lorient and Moran<sup>12</sup> against the absolute pressure as measured by a McCleod gauge in the sub-millitorr pressure range. They find that the difference is  $\sim 0.6\%$  over the pressure range  $2 \times 10^{-4}$  to  $5 \times 10^{-6}$  torr. Thus, we feel that the use of a capacitance manometer gives a trustworthy determination of the oxidant flux.

#### E. Cross section measurements

At low pressures ( $10^{-5}$  to  $10^{-4}$  torr), the chemiluminescence intensity obeys a  $p \exp(-\alpha p)$  relationship where  $p$  is the oxidant pressure.<sup>7</sup> The linear term in  $p$  describes the formation of excited state molecules and the exponential term  $\exp(-\alpha p)$  describes the attenuation of the metal beam by the oxidant. The attenuation parameter  $\alpha$  in  $\text{torr}^{-1}$  is related to the total phenomenological cross section for metal atom removal  $\sigma_{\text{tot}}$  in  $\text{\AA}^2$  by

$$\alpha = 1.33 \times 10^{-13} \frac{\ell \sigma_{\text{tot}}}{kT} \quad (3)$$

where  $\ell$  is the beam path length (cm) in the reaction chamber from the port of entry to the reaction zone viewed by the spectrometer,

$k$  is the Boltzmann constant ( $\text{erg}^\circ\text{K}^{-1}\text{-molecule}^{-1}$ ), and  $T$  is the absolute temperature. The constant  $1.33 \times 10^{-13}$  has units of  $\text{dyne-torr}^{-1}\text{-\AA}^{-2}$ . The attenuation parameter can be determined in two independent ways:

- 1) by studying the chemiluminescence intensity vs oxidant pressure for constant  $l$ ;

and

- 2) by studying the chemiluminescence intensity vs  $l$  for a constant oxidant pressure.

The first method determines  $\alpha$  from the pressure maximum

$$\alpha = \frac{1}{P_{\text{max}}} \quad (4)$$

from which  $\sigma_{\text{tot}}$  may be found using Eq. (3). A typical plot for the  $\text{Sm} + \text{N}_2\text{O}$  reaction is given in Fig. 7. The second method plots  $\ln I$  vs  $l$  (see Fig. 8); the slope of this plot is given by

$$\frac{d(\ln I)}{dl} = -1.33 \times 10^{-13} \left( \frac{P}{kT} \right) \sigma_{\text{tot}} \quad (5)$$

from which  $\sigma_{\text{tot}}$  can be directly determined. The latter method is preferable since higher oxidant pressures at  $P_{\text{max}}$  often push the metal beam into the entrance port to the reaction chamber.

The total phenomenological cross sections for the  $\text{Sm} + \text{N}_2\text{O}$ ,  $\text{Sm} + \text{F}_2$ ,  $\text{Ba} + \text{NO}_2$ , and  $\text{Ba} + \text{N}_2\text{O}$  reactions are given in Table III. For those determined by Eq. (5), the errors listed represent the maximum variation for five measurements at different pressures.

#### F. Photon yields

The chemiluminescence intensity for the  $\text{Sm} + \text{N}_2\text{O}$  reaction is given by

$$I_{\text{chem}} = k[\text{M}][\text{OX}] \quad (6)$$

under single-collision conditions where  $k$  is the rate constant. The chemiluminescence cross section  $\sigma_{\text{chem}}$  is then determined from the relation

$$I_{\text{chem}} = \sigma_{\text{chem}} \bar{v}[\text{M}][\text{OX}] \quad (7)$$

where  $\bar{v}$  is the average relative velocity of the metal atoms. Since the metal beam will be attenuated by a factor  $e^{-\alpha p}$ , this correction is included in estimating  $[M]$  in the reaction zone. Thus, the chemiluminescence cross section is given by

$$\sigma_{\text{chem}} = \frac{I_{\text{chem}}}{e^{-\alpha p} [M] [\text{OX}]} \quad (8)$$

The dimensions of  $\sigma_{\text{chem}}$  are  $\text{cm}^2$  if  $I_{\text{chem}}$  is in photons/sec,  $[M]$  is in  $\text{atoms}\cdot\text{sec}^{-1}\cdot\text{cm}^{-2}$ , and  $[\text{OX}]$  is the number of oxidant molecules contained in the observed reaction volume ( $\text{cm}^3$ ). The photon yield in percent is taken to be the ratio of the chemiluminescence cross section to the total cross section

$$\Phi = \frac{\sigma_{\text{chem}}}{\sigma_{\text{tot}}} \times 100 \quad (9)$$

Since  $\sigma_{\text{tot}}$  includes wide-angle nonreactive scattering processes (e.g. inelastic collisions),  $\Phi$  is actually a lower bound. However, when the reactive cross section is large, such as in these cases,  $\sigma_{\text{tot}}$  is expected to be a good approximation to the total reactive cross section.

## III. RESULTS

The photon yields for the reactions  $\text{Sm} + \text{N}_2\text{O}$ ,  $\text{Sm} + \text{F}_2$ ,  $\text{Ba} + \text{N}_2\text{O}$ , and  $\text{Ba} + \text{NO}_2$  were determined at various pressures. Often several measurements were made at each pressure and the results, given in Table IV, represent average values. Figures 9-12 show the actual spread in the data for each of the above reactions. The dotted lines connect the absolute photon yields obtained at pressures of several torr argon to the average values in the sub-millitorr region.

Palmer and coworkers<sup>5</sup> have measured photon yields in the 0.01-0.1 pressure regime for the  $\text{Ba} + \text{N}_2\text{O}$  and  $\text{Ba} + \text{NO}_2$  reactions. Our measurements provide a low pressure intercept that connects to their data very well. While no measurements exist in the 0.01-0.1 torr pressure range for the  $\text{Sm} + \text{N}_2\text{O}$  and  $\text{Sm} + \text{F}_2$  reactions, the dotted line should predict the photon yields where they have not been measured. The intercepts provide data that may help to model the high-pressure reaction kinetics for these systems.

The estimated uncertainties in the absolute photon yields are  $\sim 50\%$ , where the estimated uncertainty for  $\sigma_{\text{tot}}$  is  $\sim 10\%$ ,  $I_{\text{chem}}$  is  $10\%$ ,  $[\text{M}]$  is  $\sim 20\%$ , and  $[\text{OX}]$  is  $\sim 10\%$ . The most serious error

is associated with the metal flux determinations. For the reaction of  $\text{Sm} + \text{N}_2\text{O}$  at a pressure of  $8.5 \times 10^{-4}$  torr, the photon yield was measured 10 times giving  $\Phi = 0.87 \pm 0.37\%$  where the error represents one standard deviation. This error is a 43% uncertainty, but some standard deviations for the  $\text{Sm} + \text{N}_2\text{O}$  and  $\text{Ba} + \text{N}_2\text{O}$  reactions at other pressures were 10-20% of the average value. The 50% uncertainty represents an estimate of all errors, statistical and systematic. As can be seen from Table IV, the scatter of the measurements is much smaller.

We previously reported a preliminary photon yield of 0.3% for the reaction of  $\text{Sm} + \text{N}_2\text{O}$  at a pressure of  $4 \times 10^{-4}$  torr.<sup>13</sup> The value at this same pressure given in Table IV is 0.31%. The good agreement is coincidental since  $\sigma_{\text{tot}}$  for the  $\text{Sm} + \text{N}_2\text{O}$  reaction was given as  $60 \text{ \AA}^2$  using an ion gauge to measure the pressures. The present value is  $93 \text{ \AA}^2$ , taking the average of the two methods used to determine  $\sigma_{\text{tot}}$ . However, the preliminary value did provide a reasonable order of magnitude estimate.

Yokozeiki and Menzinger<sup>14</sup> recently measured relative photon yields for several Sm and Yb reactions in the  $5 \times 10^{-6}$  -  $5 \times 10^{-3}$  torr range, also using a beam-gas arrangement. They found at  $\leq 1 \times 10^{-4}$  torr that the ratio of the photon yield for the  $\text{Sm} + \text{N}_2\text{O}$  reaction

to that of the  $\text{Sm} + \text{F}_2$  reaction is 0.13. This should be compared with our photon yield ratio of 0.036. The large discrepancy arises from the difference between the total reactive cross sections used in these two studies. Because we have two independent measurements on  $\sigma_{\text{tot}}$ , we believe our values are to be preferred.

One remarkable result of this study is that the absolute photon yield for the  $\text{Sm} + \text{F}_2$  reaction is  $\sim 5\%$  under single-collision conditions. Our previous estimate was only  $\sim 1\%$  because of errors associated with the measurement of the  $\text{F}_2$  pressure. The high photon yield for the  $\text{Sm} + \text{F}_2$  reaction is very interesting because it suggests that there may be other chemical reactions with an appreciable probability for producing electronically excited products in the initial reaction step.

**ACKNOWLEDGMENT**

This research was supported by the Advanced Research Projects Agency of the Department of Defense and was monitored by the Office of Naval Research under contract N00014-76-C-0466.

## REFERENCES

1. D. J. Eckstrom, S. A. Edelstein, and S. W. Benson, *J. Chem. Phys.* 60, 2930 (1974).
2. G. Black, M. Luria, D. J. Eckstrom, S. A. Edelstein, and S. W. Benson, *J. Chem. Phys.* 61, 4932 (1974).
3. D. J. Eckstrom, S. A. Edelstein, D. L. Huestis, B. E. Perry, and S. W. Benson, *J. Chem. Phys.* 63, 3828 (1975).
4. R. H. Obenauf, C. J. Hsu, and H. B. Palmer, *J. Chem. Phys.* 57, 5607 (1972); Erratum 58, 2674 (1973); 58, 4693 (1973).
5. C. J. Hsu, W. D. Krugh, and H. B. Palmer, *J. Chem. Phys.* 60, 5118 (1974).
6. C. R. Jones and H. P. Broida, *J. Chem. Phys.* 59, 6677 (1973); 60, 4369 (1974).
7. Ch. Ottinger and R. N. Zare, *Chem. Phys. Letters* 5, 243 (1970); C. D. Jonah, R. N. Zare, and Ch. Ottinger, *J. Chem. Phys.* 56, 263 (1972); J. L. Gole and R. N. Zare, *J. Chem. Phys.* 57, 5331 (1972); R. C. Oldenborg, J. L. Gole, and R. N. Zare, *J. Chem. Phys.* 60, 4032 (1974).
8. R. Stair, W. E. Schneider, and J. K. Jackson, *Appl. Opt.* 2, 1151 (1963). The standard lamp supplied by Optronics Laboratories is certified by W. E. Schneider.

9. C. R. Dickson, Ph.D. Thesis, Columbia University (1976).
10. J. O. Kraehenbuehl, Electrical Illumination (J. Wiley & Sons, N.Y., 1942), pp. 107-108.
11. W. E. Barrows, Light, Photometry, and Illumination (McGraw-Hill, Inc., N.Y., 1912), pp. 229-231.
12. G. Loriot and T. Moran, Rev. Sci. Instr. 46, 140 (1975).
13. C. R. Dickson and R. N. Zare, Chem. Phys. 7, 361 (1975).
14. A. Yokozeke and M. Menzinger, Chem. Phys. 14, 427 (1976).

## FIGURE CAPTIONS

Fig. 1. Beam-gas chemiluminescent reaction of  $\text{Sm} + \text{N}_2\text{O}$  taken at a scan rate of  $500 \text{ \AA}/\text{min}$  and at a resolution of  $5 \text{ \AA}$ .

Fig. 2. Metal atom source. A few hundred amperes are passed through a graphite cylinder, held between two water-cooled copper bussbars. The graphite heater has slots cut on its body to increase the resistance. Inside the heater and supported from one end is a graphite crucible containing the metal sample.

Fig. 3. (a) The spectrum of the standard lamp output, which is multiplied by the correction factor (b) to obtain (c) the relative photon flux of the standard lamp.

Fig. 4. Spectrometer and optics alignment with a He-Ne laser.

Fig. 5. Photon flux measurement apparatus.

Fig. 6. Metal flux determination using a thin, hollow, glass sphere.

Fig. 7. Determination of  $\sigma_{\text{tot}} = 82 \text{ \AA}^2$  from the pressure maximum for  $\text{Sm} + \text{N}_2\text{O}$ .

Fig. 8. Determination of  $\sigma_{\text{tot}} = 91 \text{ \AA}^2$  from the variation of the chemiluminescence with path length for  $\text{Sm} + \text{N}_2\text{O}$ . This number was included in the average reported in Table III.

Fig. 9. Absolute photon yields as a function of pressure for the  $\text{Sm} + \text{N}_2\text{O}$  reaction: (o) this work; and ( $\Delta$ ) Ref. 3.

Fig. 10. Absolute photon yields as a function of pressure for the  $\text{Sm} + \text{F}_2$  reaction: (o) this work; and ( $\Delta$ ) Ref. 3.

Fig. 11. Absolute photon yields as a function of pressure for the  $\text{Ba} + \text{N}_2\text{O}$  reaction: (o) this work; ( $\Delta$ ) Ref. 3; and ( $\square$ ) Ref. 6.

Fig. 12. Absolute Photon yields as a function of pressure for the  $\text{Ba} + \text{NO}_2$  reaction: (o) this work; ( $\bullet$ ) Ref. 5; and ( $\Delta$ ) Ref. 6.

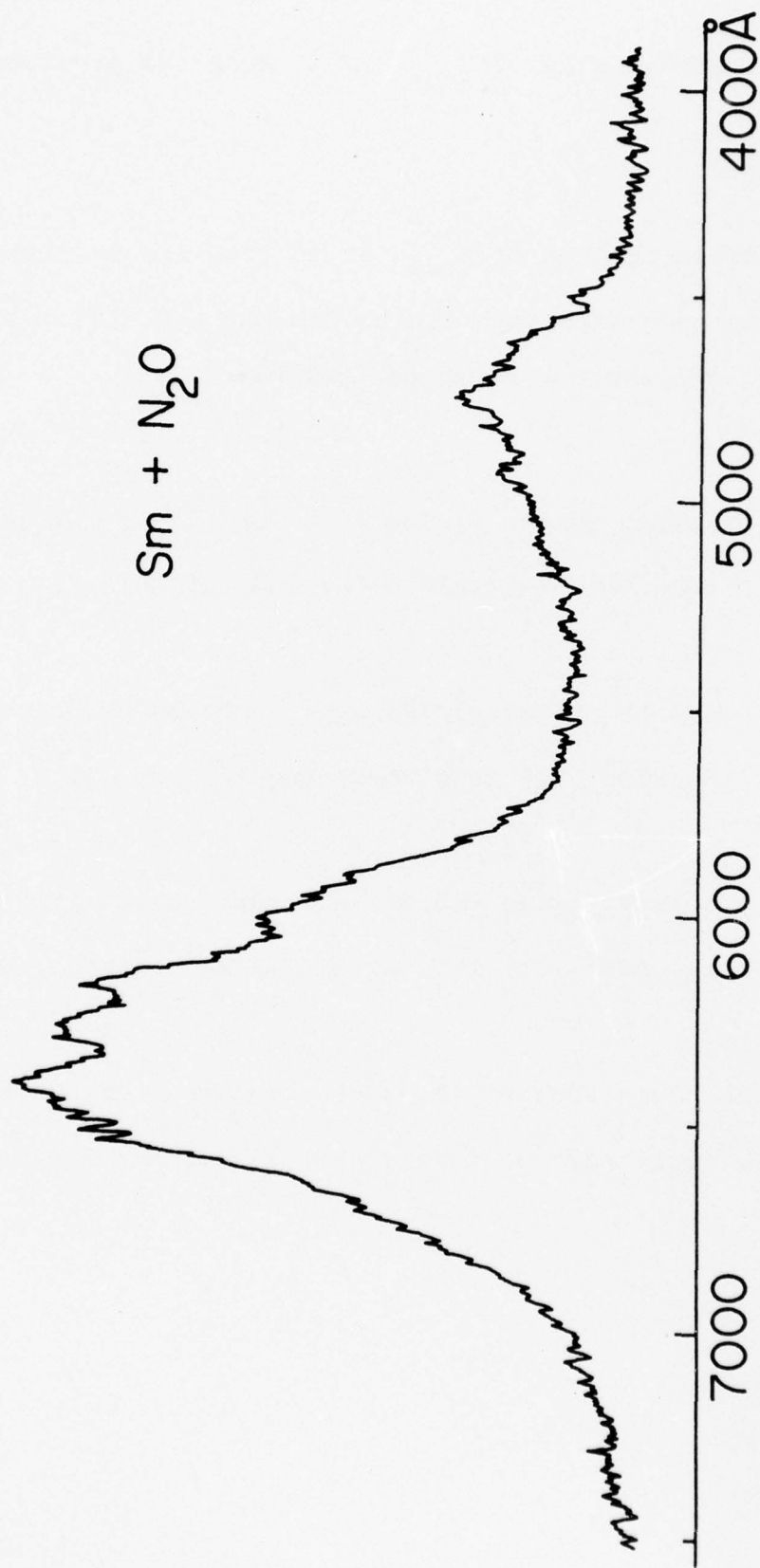

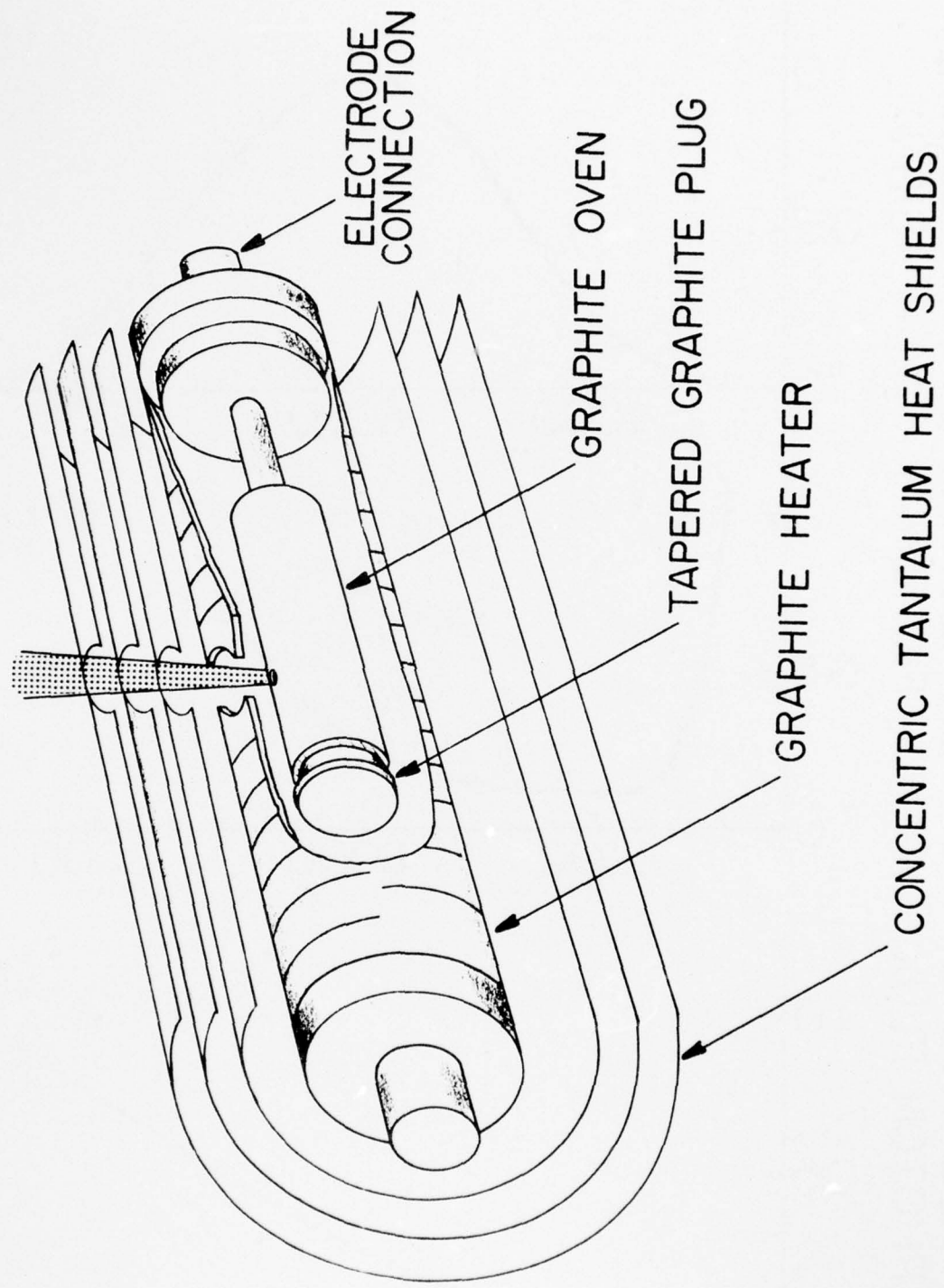

ELECTRODE CONNECTION

GRAPHITE OVEN

TAPERED GRAPHITE PLUG

GRAPHITE HEATER

CONCENTRIC TANTALUM HEAT SHIELDS

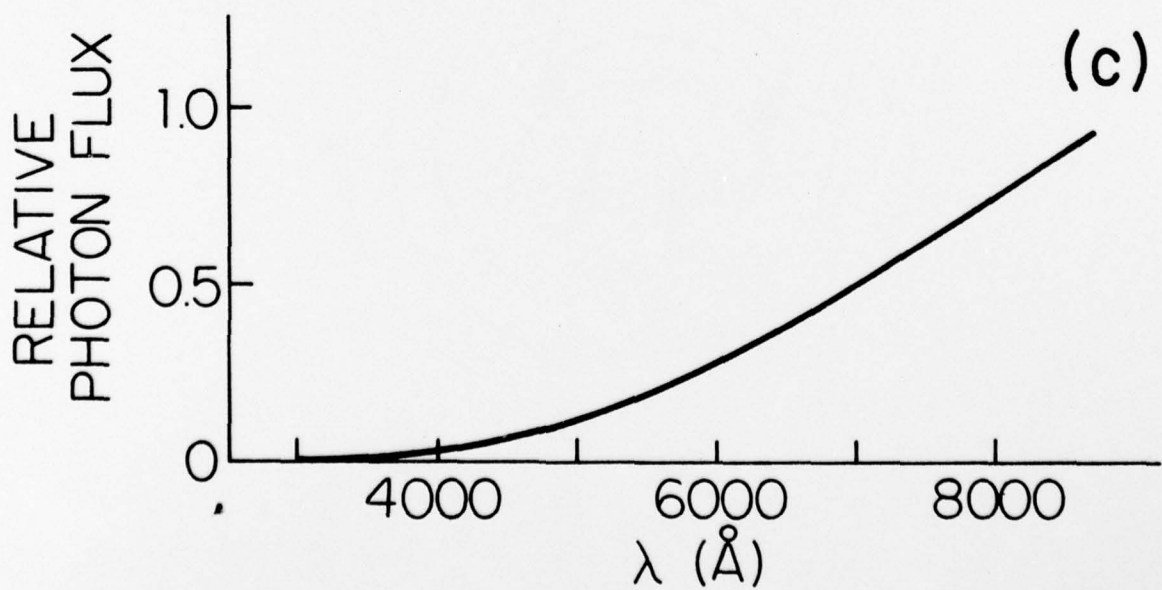
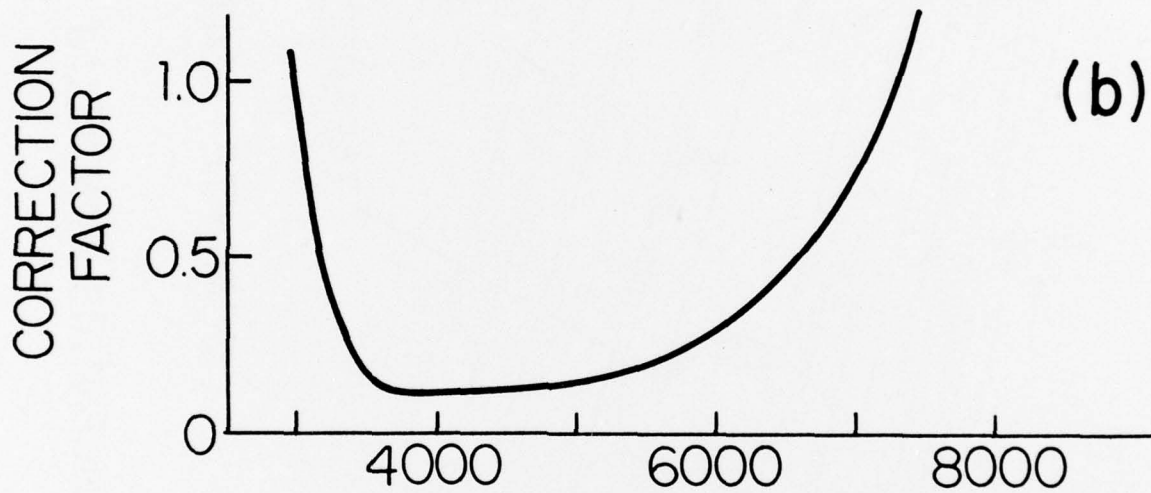
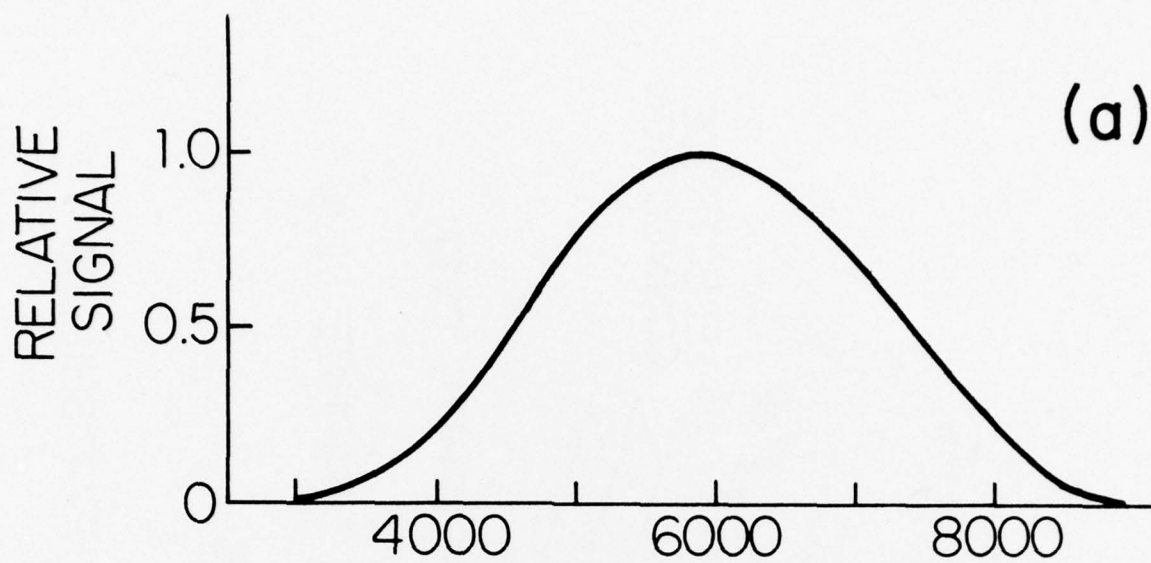

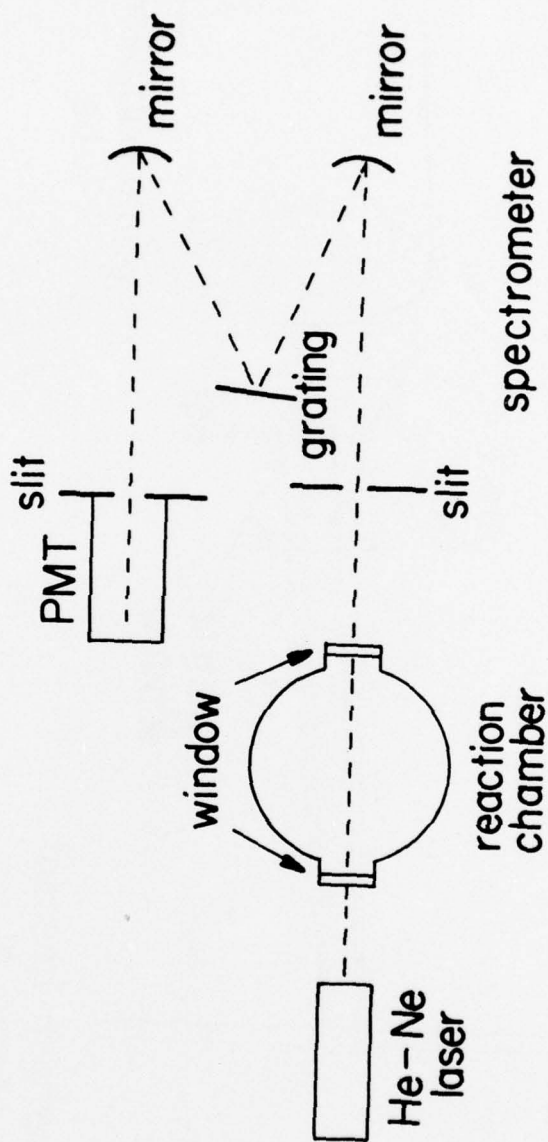

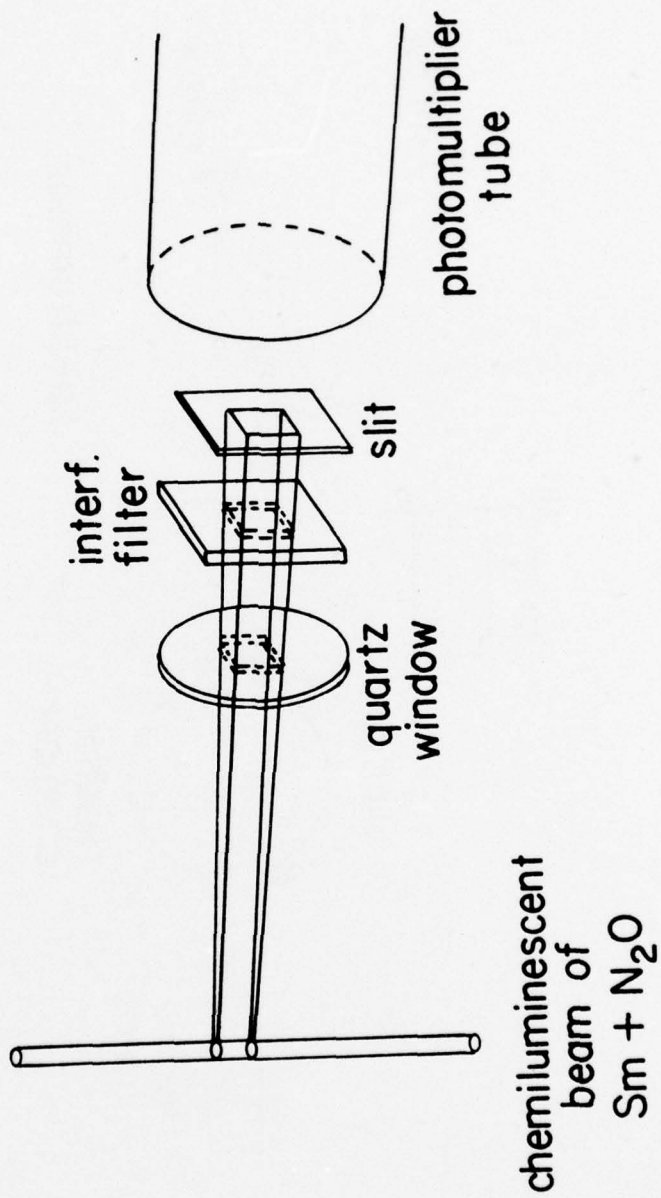

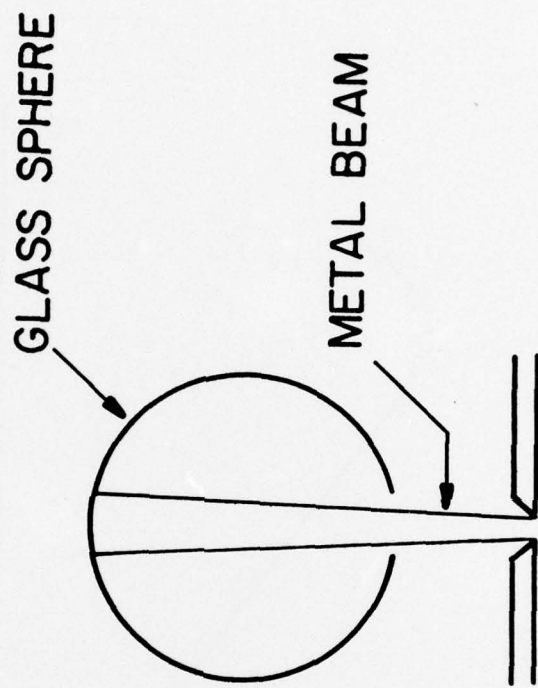

Fig. 6

Fig. 7

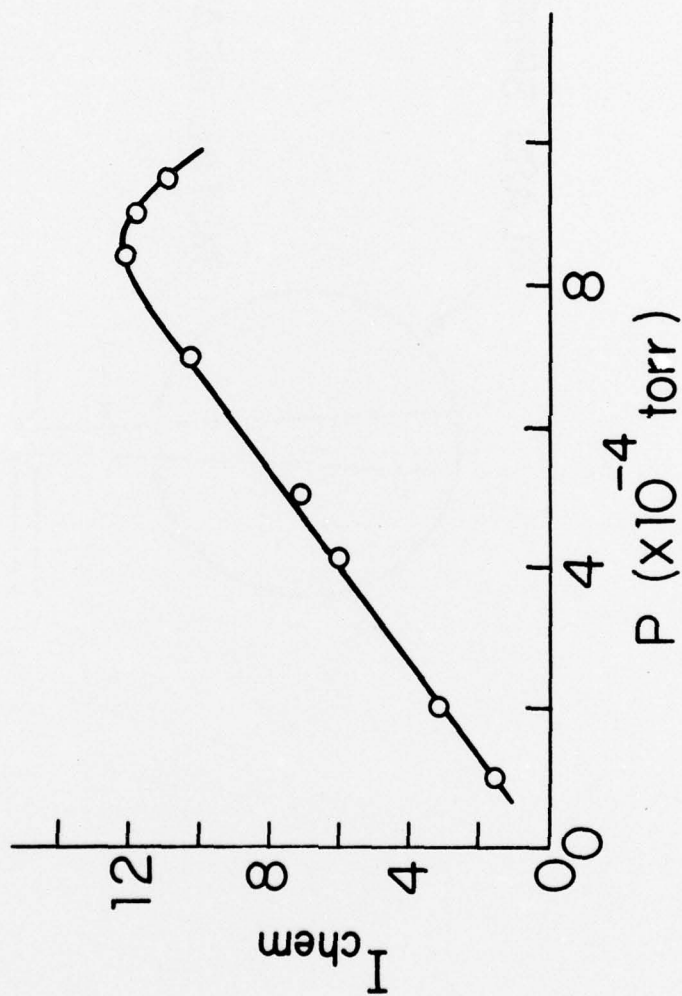
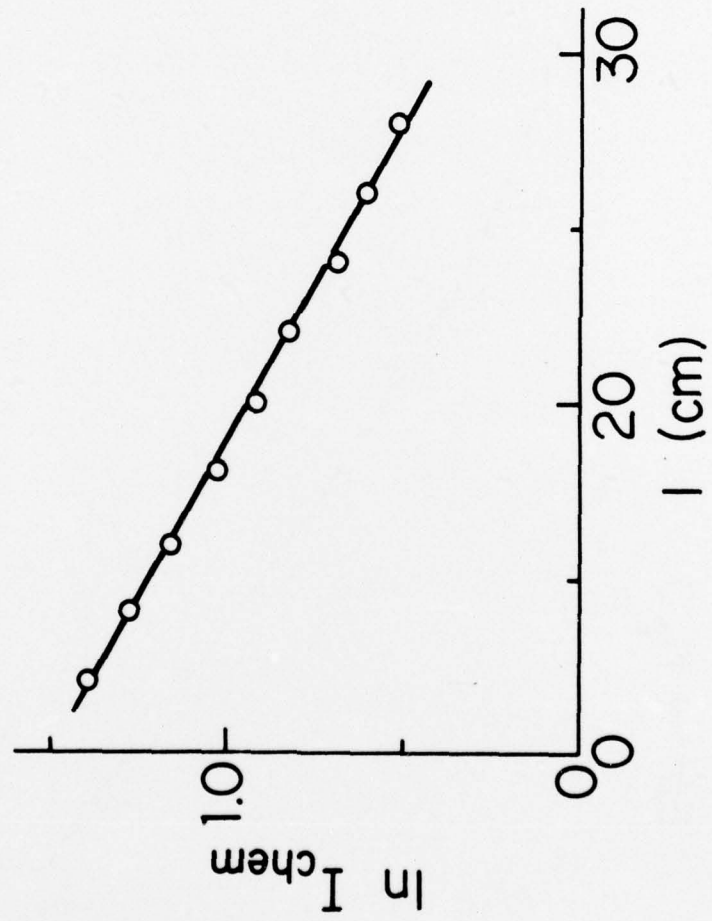
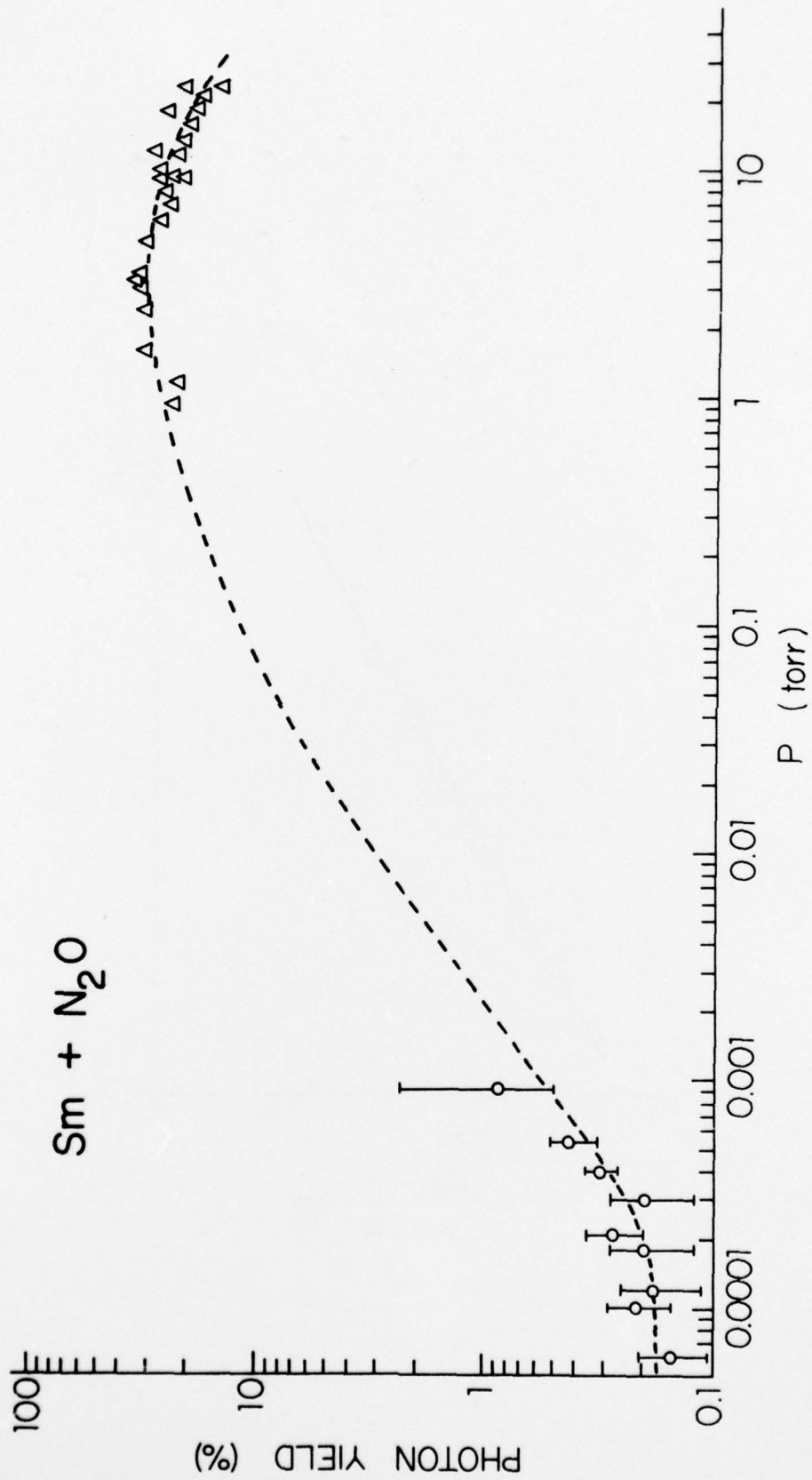
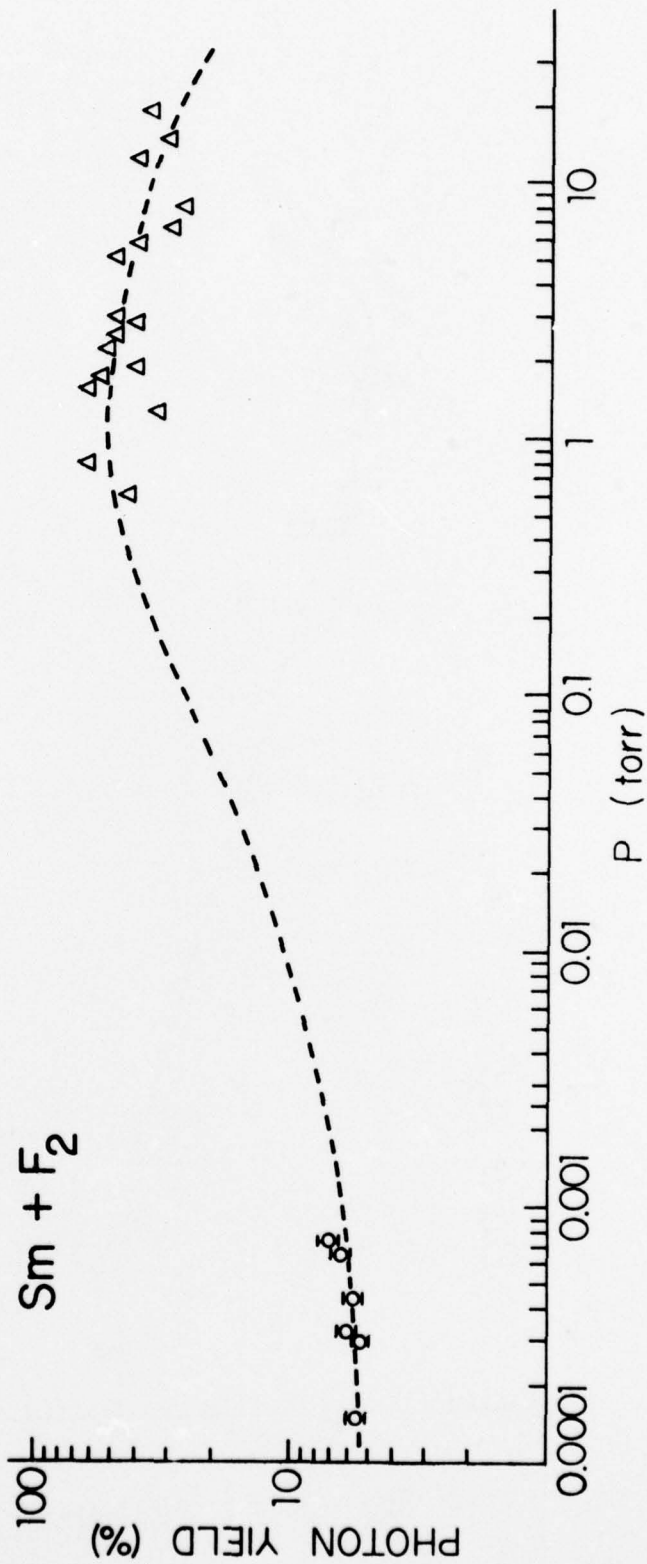
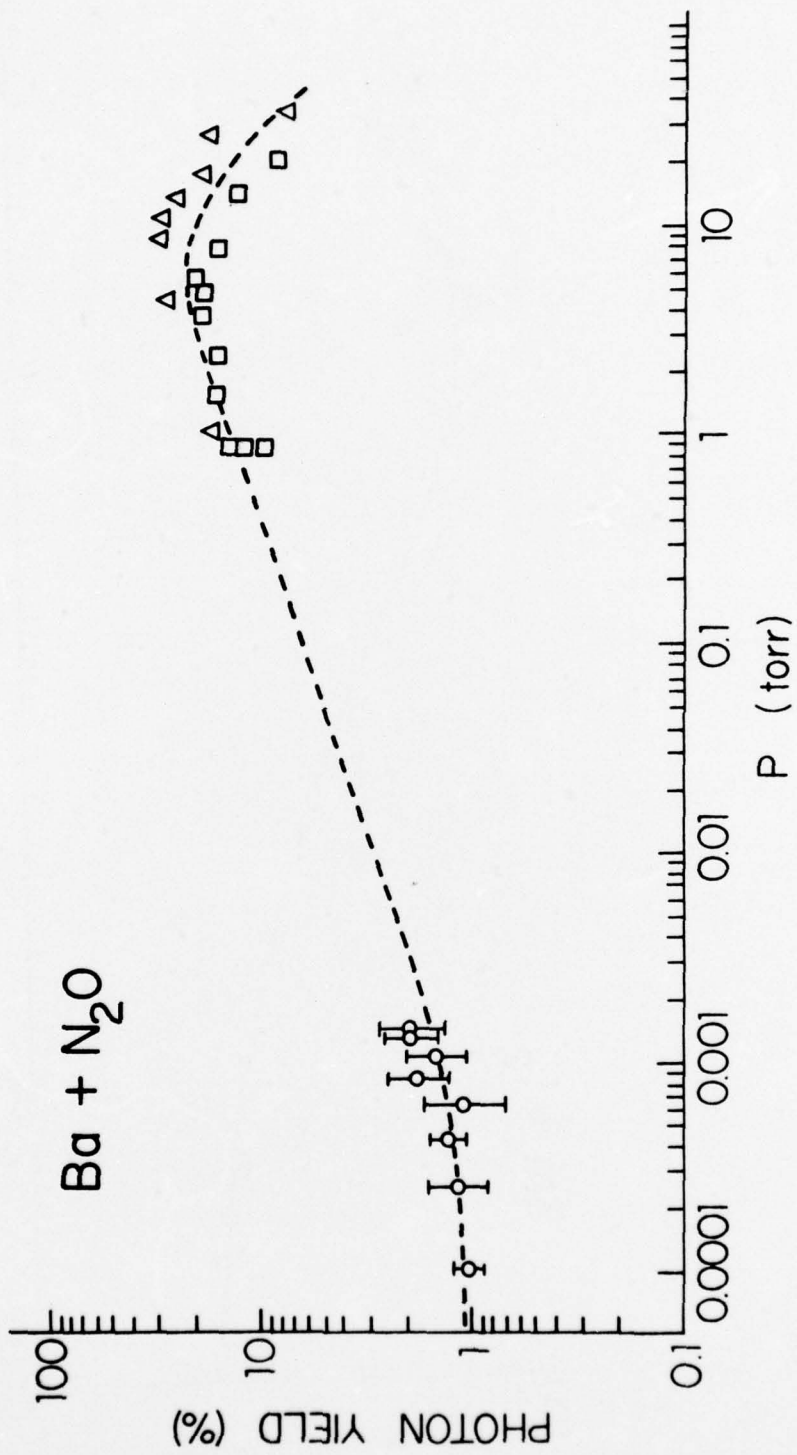

Fig. 8









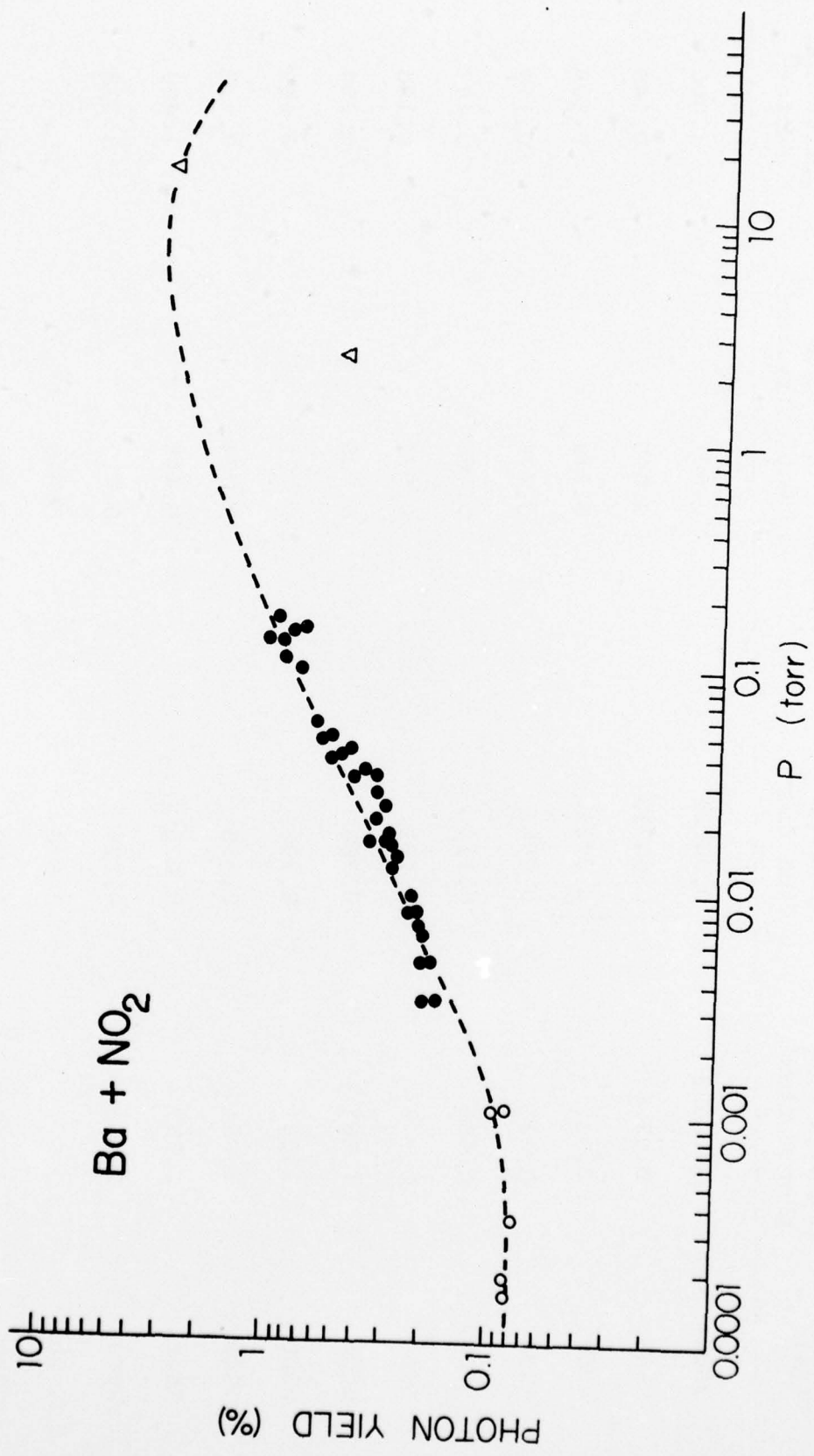

Table I. Correction factors for chemiluminescent spectra

$\lambda$ (Å)	standard lamp photon flux <sup>a</sup>	relative photon flux <sup>b</sup>	relative signal from optical-detection system <sup>c</sup>	correction factor <sup>d</sup>
3000	0.00409	0.00124	0.001	1.000
3500	0.0288	0.00713	0.049	0.146
4000	0.0891	0.0221	0.202	0.109
4500	0.227	0.0562	0.475	0.118
5000	0.460	0.114	0.764	0.149
5500	0.773	0.191	0.973	0.196
6000	1.163	0.288	0.980	0.294
6500	1.601	0.396	0.881	0.449
7000	2.051	0.508	0.704	0.722
7500	2.515	0.623	0.445	1.400
8000	2.908	0.720	0.217	3.318
9000	3.557	0.880	0.016	55.
10000	4.040	1.000	0.008	125.

<sup>a</sup>photons-sec<sup>-1</sup>-cm<sup>-2</sup>-nm<sup>-1</sup> × 10<sup>12</sup>

<sup>b</sup>see Fig. 3c

<sup>c</sup>see Fig. 3a

<sup>d</sup>see Fig. 3b

Table II. Phototube and interference filter calibration

$\lambda$ (Å)	FWHM (Å)	phototube calibration <sup>a</sup>
6328.0	34	$3.99 \times 10^{14}$
5262.5	17.5	$8.39 \times 10^{14}$
4418.0	33	$1.97 \times 10^{14}$

<sup>a</sup>photons-sec<sup>-1</sup>-nm<sup>-1</sup>-cm<sup>-2</sup>-amp<sup>-1</sup>

Table III. Total phenomenological cross sections

Reaction	$\sigma_{\text{tot}} (\text{\AA}^2)$	
	$I_{\text{chem}}$ vs length <sup>a</sup>	$I_{\text{chem}}$ vs pressure <sup>b</sup>
Sm+N <sub>2</sub> O	89±6	82
Sm+F <sub>2</sub>	99±8	95
Ba+NO <sub>2</sub>	-	122
Ba+N <sub>2</sub> O	82±6	92

<sup>a</sup>See Eq. (5)

<sup>b</sup>See Eq. (4)

Table IV. Absolute photon yields (%) as a function of pressure<sup>a</sup>

P (10 <sup>-4</sup> torr)	Sm+N <sub>2</sub> O	Sm+F <sub>2</sub>	Ba+N <sub>2</sub> O	Ba+NO <sub>2</sub>
0.6	0.15±0.06	-	-	-
1.0	0.22±0.07	-	1.05±0.08	0.09
1.2	0.18±0.07	-	-	0.08
1.5	-	5.5±0.4	-	-
1.8	0.20±0.08	-	-	-
2.0	0.28±0.08	-	1.13±0.27	-
2.1	-	-	-	0.08
3.0	-	5.1±0.3	1.21±0.18	-
3.2	-	6.0±0.5	-	-
4.0	0.31±0.04	-	1.09±0.38	-
4.4	-	5.6±0.4	-	-
5.0	0.42±0.11	-	1.60±0.40	-
6.0	-	-	1.36±0.34	-
6.5	-	6.3±0.3	-	-
6.7	-	-	-	0.09
7.0	-	-	1.73±0.43	-
7.3	-	7.0±0.4	-	-
7.5	-	-	1.69±0.45	-
8.5	0.87±0.37	-	-	-

<sup>a</sup>Error estimates represent one standard deviation.