

AD-A034 736

HUMAN ENGINEERING LAB ABERDEEN PROVING GROUND MD  
APPARATUS FOR TELEPHONE-TONE STUDY.(U)  
SEP 76 O C WOLFE

F/G 17/2

UNCLASSIFIED

HEL-TN-5-76

NL

1 OF 1  
AD-A  
034 736

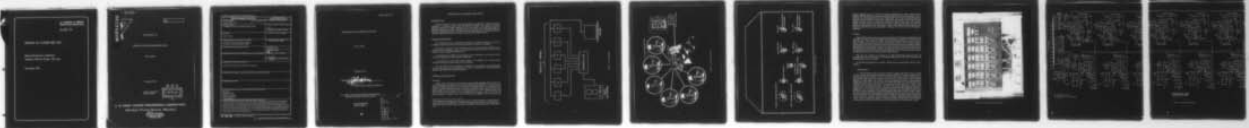

END  
DATE  
FILMED  
3-14-77  
NTIS

U.S. DEPARTMENT OF COMMERCE  
National Technical Information Service

AD-A034 736

APPARATUS FOR TELEPHONE-TONE STUDY

HUMAN ENGINEERING LABORATORY  
ABERDEEN PROVING GROUND, MARYLAND

SEPTEMBER 1976

027053

ADA 034736

AD

Technical Note 5-76

APPARATUS FOR TELEPHONE-TONE STUDY

Otho C. Wolfe

September 1976

Approved for public release;  
distribution unlimited.

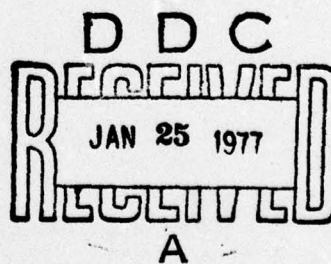

U. S. ARMY HUMAN ENGINEERING LABORATORY  
Aberdeen Proving Ground, Maryland

REPRODUCED BY  
NATIONAL TECHNICAL  
INFORMATION SERVICE  
U. S. DEPARTMENT OF COMMERCE  
SPRINGFIELD, VA. 22161

REPORT DOCUMENTATION PAGE		READ INSTRUCTIONS BEFORE COMPLETING FORM
1. REPORT NUMBER Technical Note 5-76	2. GOVT ACCESSION NO.	3. RECIPIENT'S CATALOG NUMBER
4. TITLE (and Subtitle) APPARATUS FOR TELEPHONE-TONE STUDY		5. TYPE OF REPORT & PERIOD COVERED Final
		6. PERFORMING ORG. REPORT NUMBER
7. AUTHOR(s) Otho C. Wolfe		8. CONTRACT OR GRANT NUMBER(s)
9. PERFORMING ORGANIZATION NAME AND ADDRESS U.S. Army Human Engineering Laboratory Aberdeen Proving Ground, MD 21005		10. PROGRAM ELEMENT, PROJECT, TASK AREA & WORK UNIT NUMBERS
11. CONTROLLING OFFICE NAME AND ADDRESS		12. REPORT DATE September 1976
		13. NUMBER OF PAGES 14
14. MONITORING AGENCY NAME & ADDRESS (if different from Controlling Office)		15. SECURITY CLASS. (of this report) Unclassified
		15a. DECLASSIFICATION/DOWNGRADING SCHEDULE
16. DISTRIBUTION STATEMENT (of this Report) Approved for public release; distribution unlimited.		
17. DISTRIBUTION STATEMENT (of the abstract entered in Block 20, if different from Report)		
18. SUPPLEMENTARY NOTES		
19. KEY WORDS (Continue on reverse side if necessary and identify by block number) Simulation Telephone Tones Telephone Warning Human Engineering Communications		
20. ABSTRACT (Continue on reverse side if necessary and identify by block number) This report describes the technical principles used in designing and developing a tone-presentation system capable of presenting 16 tones to six subjects over telephone sets, for closely controlled presentation times. This experimental apparatus system was used to evaluate the suitability of proposed tones and tone combinations for use in a future telephone system. A 14-channel tape recorder was used to store the library of test tones. The remainder of the system required custom design to meet criteria of the experimental design. This tone-presentation system can readily be adapted to a wide range of other similar studies or tests.		

APPARATUS FOR TELEPHONE-TONE STUDY

Otho C. Wolfe

September 1976

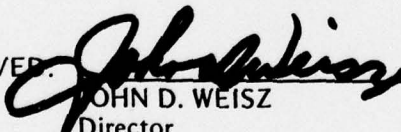
APPROVED:   
JOHN D. WEISZ  
Director  
U. S. Army Human Engineering Laboratory

U. S. ARMY HUMAN ENGINEERING LABORATORY  
Aberdeen Proving Ground, Maryland 21005

Approved for public release;  
distribution unlimited.

ia

NO. POSITION	
NTIS	WHL Section <input checked="" type="checkbox"/>
DDC	Ext. Section <input type="checkbox"/>
UNANNOUNCED	<input type="checkbox"/>
JUSTIFICATION	<input type="checkbox"/>
BY	<input type="checkbox"/>
DISTRIBUTION/AVAILABILITY CODES	
Dist.	AVAIL. AND CONTROL
AA	

# APPARATUS FOR TELEPHONE-TONE STUDY<sup>1</sup>

## INTRODUCTION

In order to study some tones and tone combinations proposed for warning and status reporting in a telephone system under development, equipment was required to simulate operating conditions and signals planned for the future system. The experiment required a method of obtaining the tones, presenting them to six subjects on their individual telephones, starting or stopping the signals in response to operations performed with each telephone set, and communicating from experimenter to subjects over the regular telephone circuit.

## GENERAL DESCRIPTION

The system consists of an experimenter's telephone, six subjects' telephones, a 14-channel recorder, a controller, and interconnecting cables. Figure 1 shows the system diagram.

The tones are recorded on the 14-channel recorder and are played back through the tone controller. Since 16 different sounds are required, two of them are derived from one of the original tones by chopping it at different rates.

The controller was designed and constructed so the experimenter could select tones and control their presentation to the six subjects' telephones.

It was necessary to make some minor changes in the telephone sets to utilize certain switches on the sets to perform functions in the controller.

The same tone and test conditions are presented to each subject's set simultaneously; however, each subject set has a separate circuit, which is controlled by the individual subject's response. Figure 2 shows the system in operation.

## CONTROLLER DESCRIPTION

### Functional

Figure 3 shows the operator's panel. There are two channels designated "Hook" and "Key." The functioning of each channel is very similar, though minor differences will be noted. The "Selector" switches permit the tones to be routed to the desired channel. An "On-Off" switch allows the operator additional control of the tones. Presentation time is controlled by the next switch which has three positions: "On," "On One Second" and "Off." With the switch in the "On" position the tone is turned on when triggered and remains on, while in the "On One Second" position it remains on for only one second when triggered. The two channels use

---

<sup>1</sup>This apparatus was designed and constructed for use in a test described in U. S. Army Human Engineering Laboratory TM 30-76, "Subscriber Effectiveness As a Function of Signaling Tones Associated with the AN/TTC-39 Circuit Switch," by Phelps, R.M., Maloney, M.V., and Peterson, L.A.

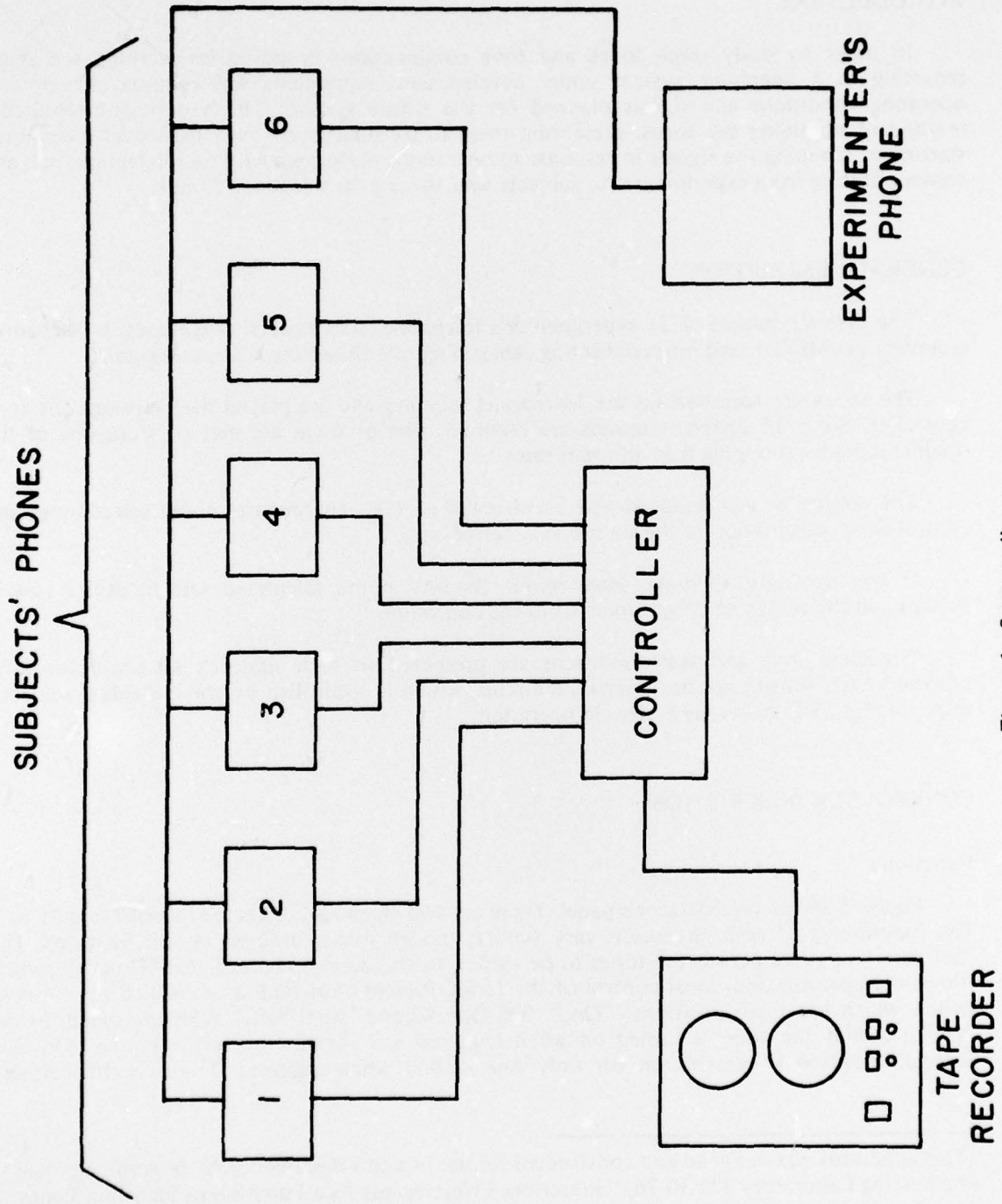

Figure 1. System diagram.

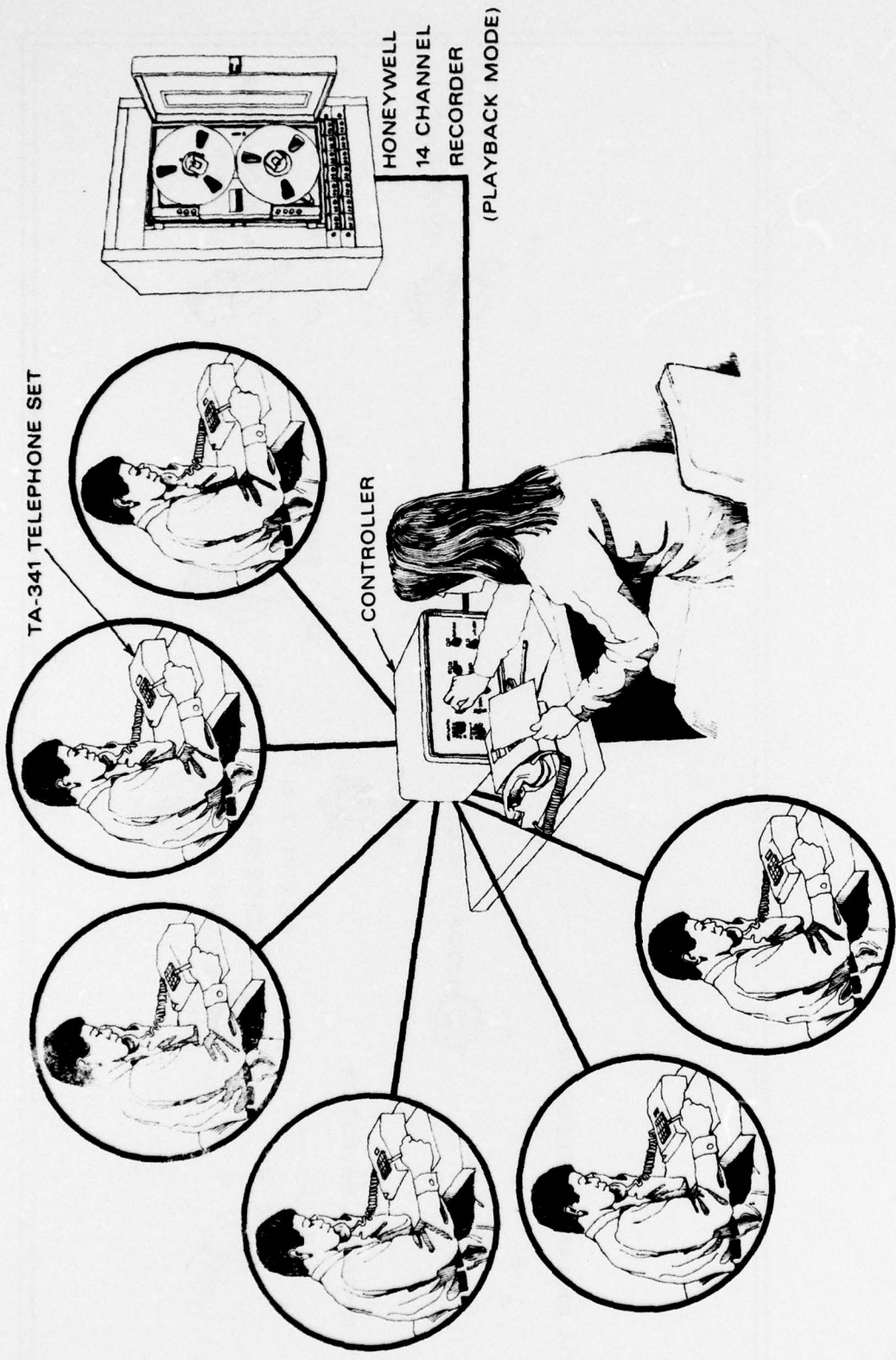

Figure 2. System in operation.

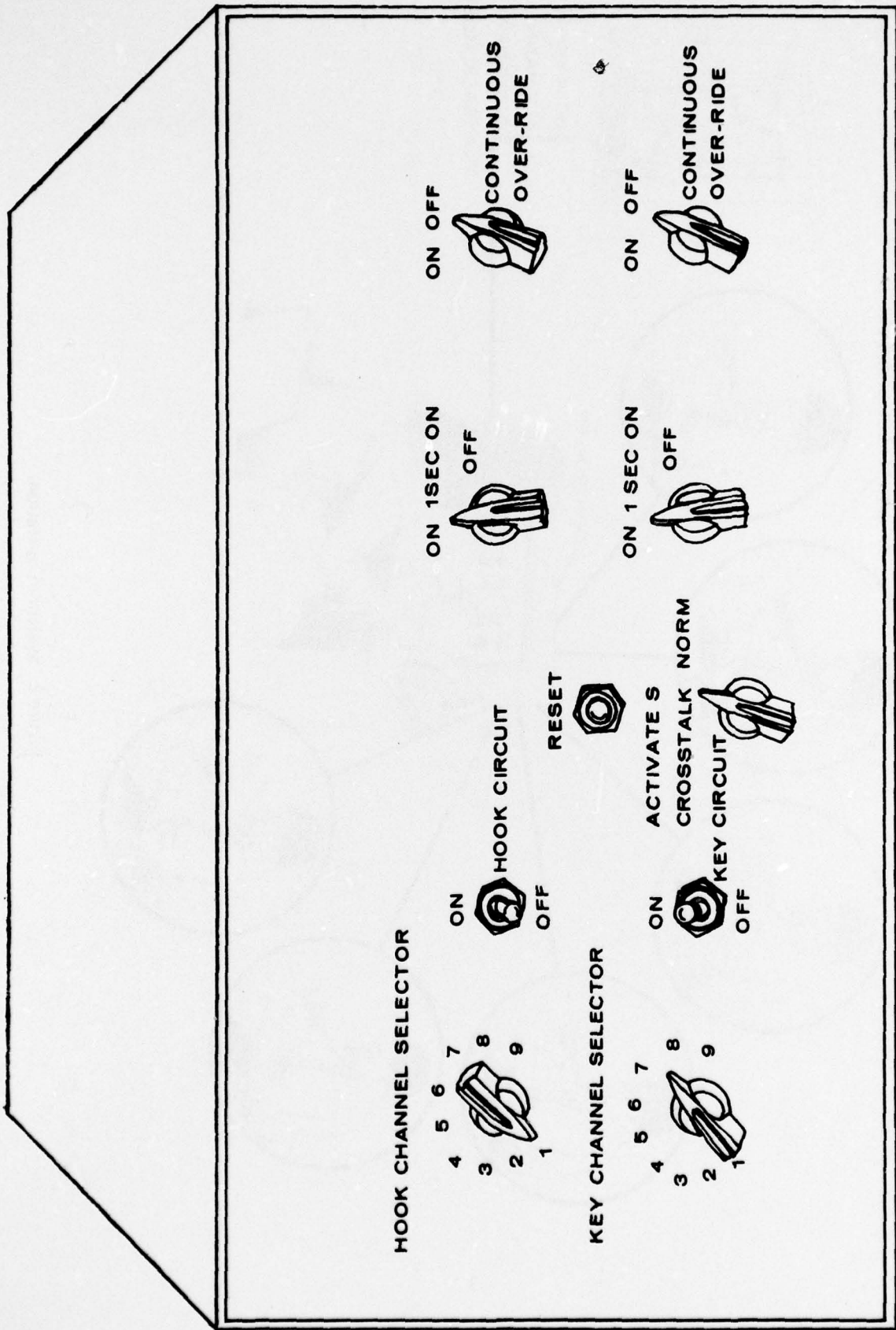

Figure 3. Operator's panel.

different triggering sources. In the "Hook" channel, triggering occurs when a subject lifts the telephone receiver off the hook. When a subject pushes any button in the right column on the telephone, the "Hook-Channel" tone stops. Triggering the "Key" channel requires pressing any button in the left column; however, there is no provision for subjects to stop the tone in this channel. All time circuits are restored by pressing the "Reset" button. The "Off" position disables the time circuits, so that when the next switch, "Continuous Over-Ride," is in the "On" position, it will present the tone continuously. Another switch near the center of the panel, just below the "Reset," allows the experimenter to interrupt the "Send" line from the subjects' telephones.

#### Technical

Figure 4 shows the parts layout and construction. Figure 5 is the electronic schematic of the controller. The tones are presented through two different paths designated "Hook Channel" and "Key Channel." Their circuits are similar. Tones come from the recorder to the controller's selector switches for each channel. Each switch has nine positions, with a different recorder output going to each position except that two of the outputs go to each of the selector switches. One tone fed to the hook-selector switch also goes to two relays that chop the signal—either one-half second on and one-half second off, or one-fourth second on and one-fourth second off. The key-selector switch then uses these chopped signals for two of its tones. These two, plus the 14 distinctive tones from the recorder, give the 16 required tones.

The two relay choppers are actuated by an astable multivibrator using the type 555 integrated-circuit unit. The frequency of chopping is determined by the values of resistors and capacitors used in the timing circuit.

In the following description, the "Hook" channel will be considered first, then the "Key" channel.

#### "Hook Channel"

From the selector switch, the tone is routed to a toggle switch which acts as a master "On-Off" control, then through the normally open contacts of the "Timer"-controlled relay to the normally closed contacts of a "Stop" relay. (The "Continuous Over-Ride" switch bypasses both of these relays.) The tone then goes to the base of an emitter follower which drives the telephone's receiver element. The "Timer" circuit is an integrated-circuit timer in the monostable configuration, again using a 555-type unit. The resistor and capacitor in the timing circuit are selected to give a time of one second. The output of the timer drives the "Timer" relay, controlling the tone-presentation time. A selector switch in the triggering circuit permits the output to be on for just one second, or remain on continuously after triggering. The timer is triggered by a set of contacts on the telephone's hook switch, when the handset is lifted. When the "Stop" relay is energized, its contacts interrupt the signal path. This occurs when a subject pushes any button in the right column of the telephones, thus closing the key-switch contacts. The relay's holding circuit is established through a second set of normally open contacts on the "Stop" relay, and a normally closed contact on a "Reset" push-button switch. Pressing the "Reset" button re-establishes a signal path. There is one master "Reset" button on the controller which performs this function for all six pairs of "Hook Channel" and "Key Channel" circuits.

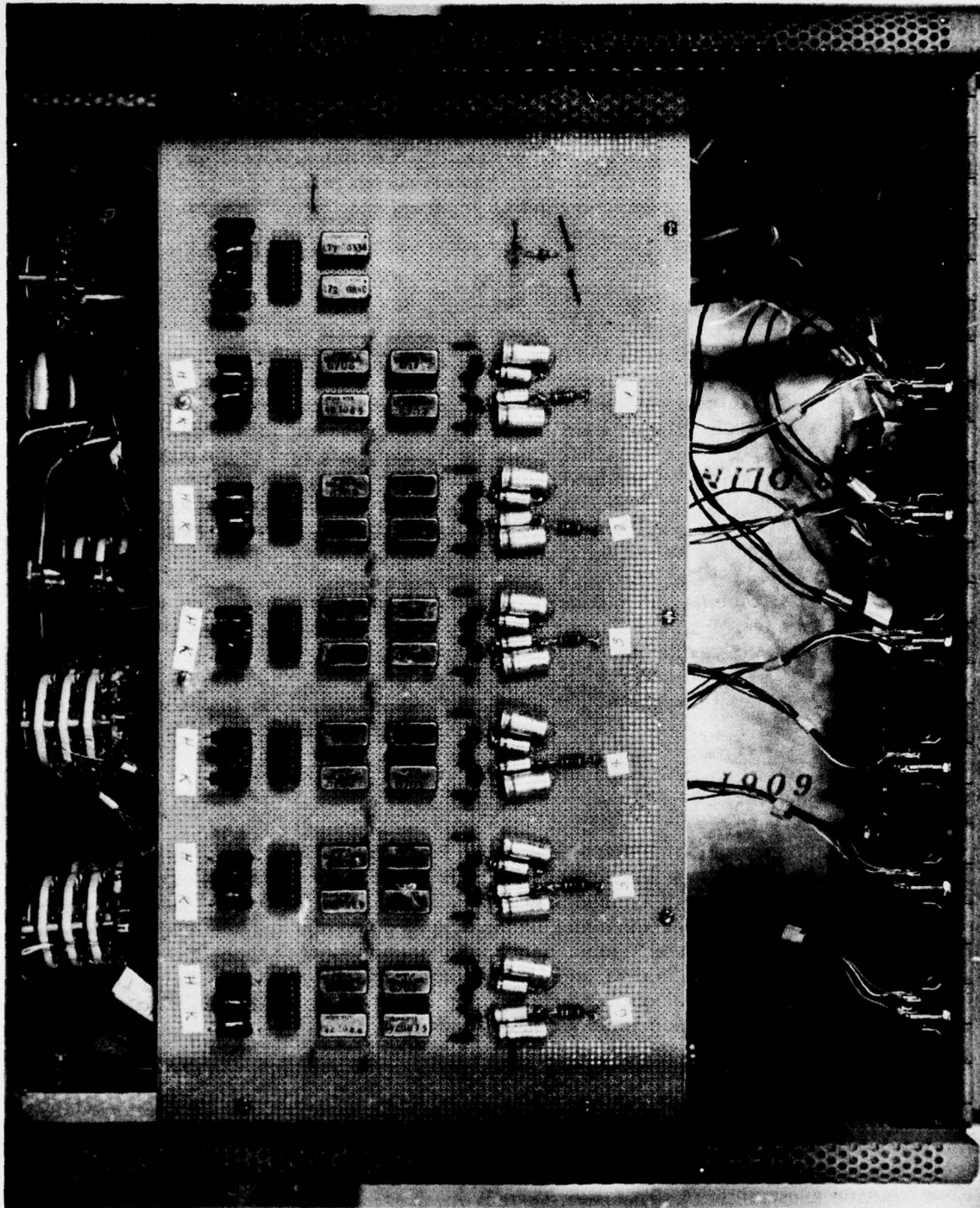
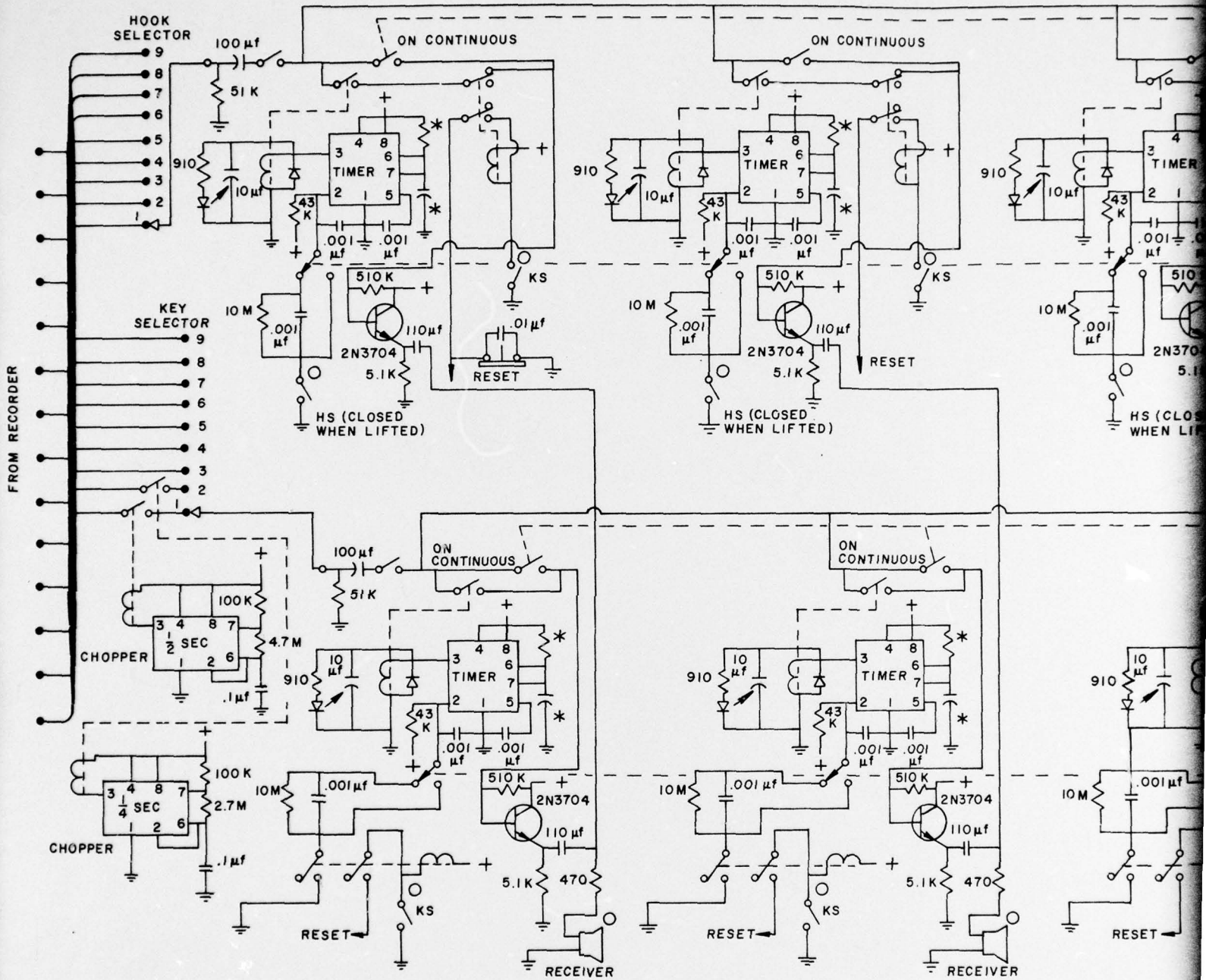
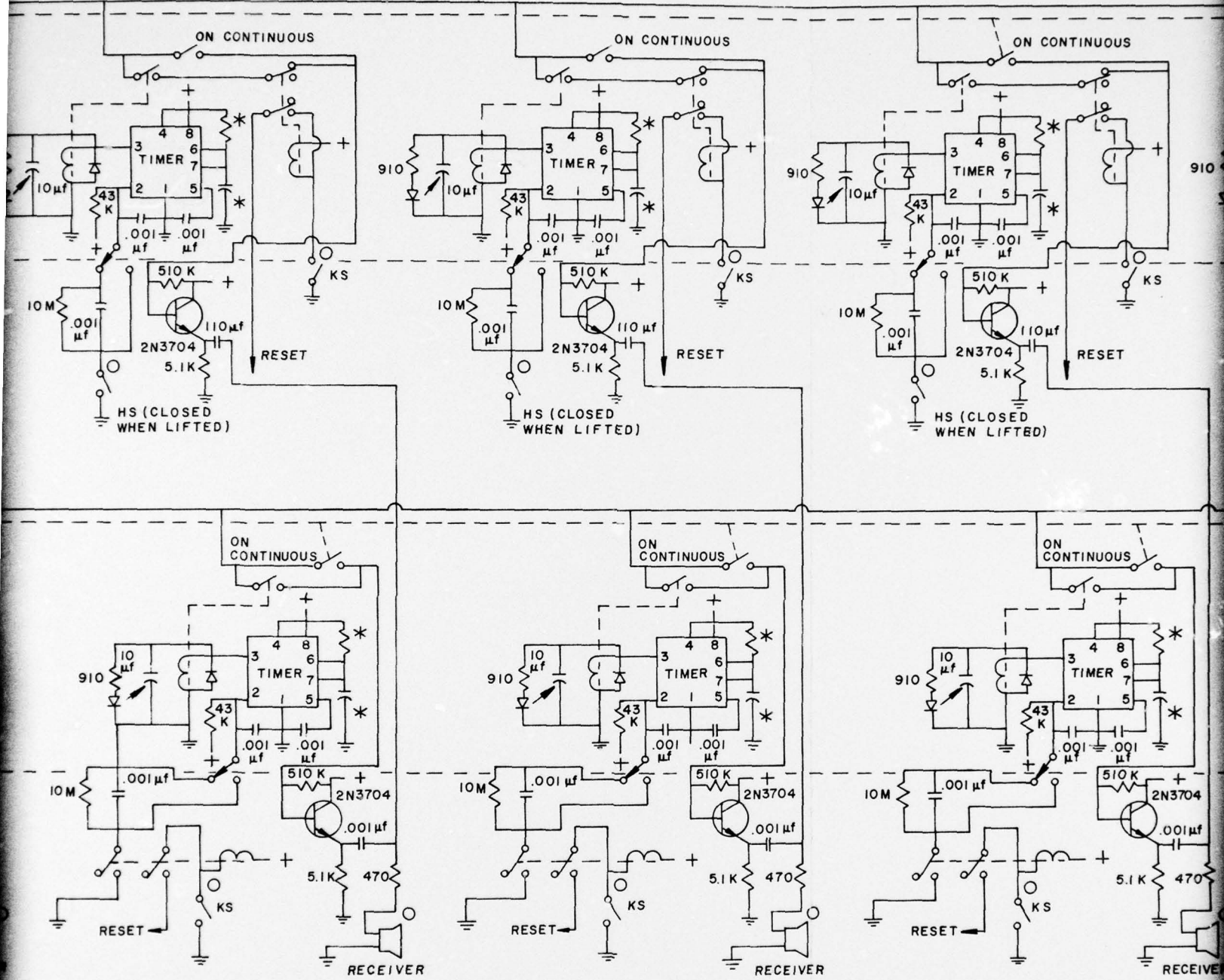

Figure 4. Parts layout and construction



\* SELECTED VALUES  
 ○ CONNECTED TO TELEPHONE SET

A



**CONTROLLER**

Figure 5. Electronic schematic.

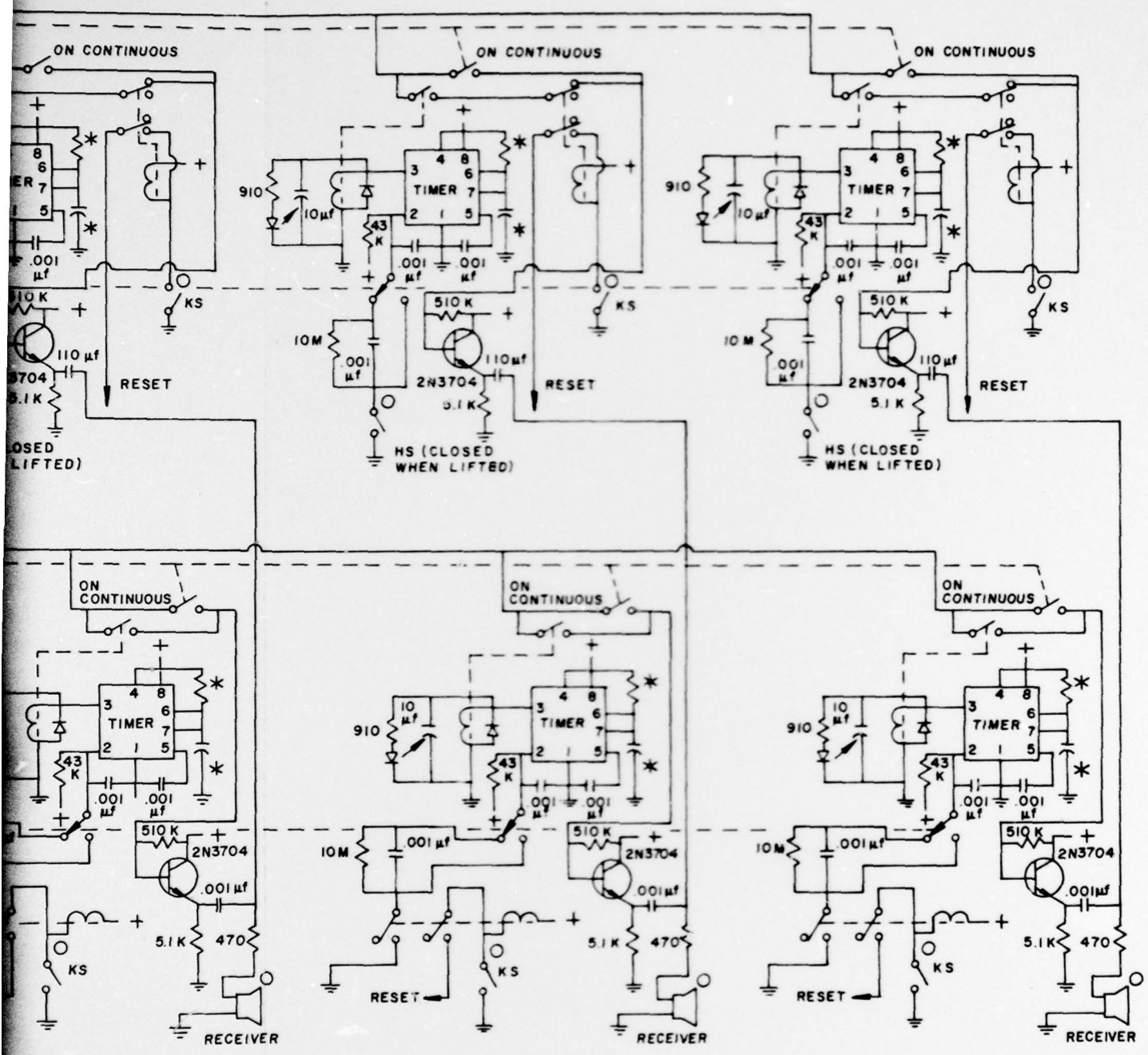

### "Key Channel"

As with the "Hook Channel," the tones come from the selector switch, through an "On-Off" switch, to the normally open contacts of the "Timer"-controlled relay, finally reaching the base of an emitter follower, whose output is mixed with the output from the "Hook Channel" to drive the telephone's receiver element. This channel also has a "Continuous Over-Ride" switch that bypasses the relay contacts. The "Timer" circuit is identical to the one used in the "Hook Channel," except for triggering. This timer must be started when any push-button in the left column on the telephone is depressed. Since the push-button only gives a momentary contact, and triggering the circuit requires a continuous contact, the push-button's momentary closure is used to energize a holding relay. The second set of normally open contacts on the relay, together with the "Reset" button, make a holding circuit that keeps the relay energized until the "Reset" button is pushed. The tones are connected to each telephone set by a cable. This cable also couples the telephone set's switch operations to the controller.

### MODIFICATIONS TO TELEPHONES

Six TA-341 telephone sets were connected in the "point-to-point" mode so they could be used without terminal equipment. In this mode, lifting the handset off the hook normally initiates a ringing signal; to disable this ringing, one wire was disconnected from each switch terminal. Wires were also removed from the key switches for columns one and three, and new wires were connected so these switches could be used in the controller circuitry. Two other wires were disconnected from a set of contacts on the "Hook" switch, so that it could be used to trigger timer circuits in the controller. Finally, connections were made to the circuit card's socket pins so test tones could be fed in.

### DISCUSSION

This system was developed for a particular tone study. However, it incorporates the necessary versatility to accommodate a broad range of other similar testing.

To change the vocabulary of available tones, it is only necessary to substitute other tapes, or to make new recordings incorporating any proposed or desired tones or signals. Any similar recorder could be substituted for the one used here. The presentation time may easily be modified or altered by changing the values of resistors or capacitors in the timing circuits.

This versatile signal-presentation system can also be used to present tones over other or future telephone designs, so long as the telephones are modified and cabled to be compatible with the controller.

**Preceding page blank**